

knitking

magazine





dk 720

dk 724



dk 722



DK 727

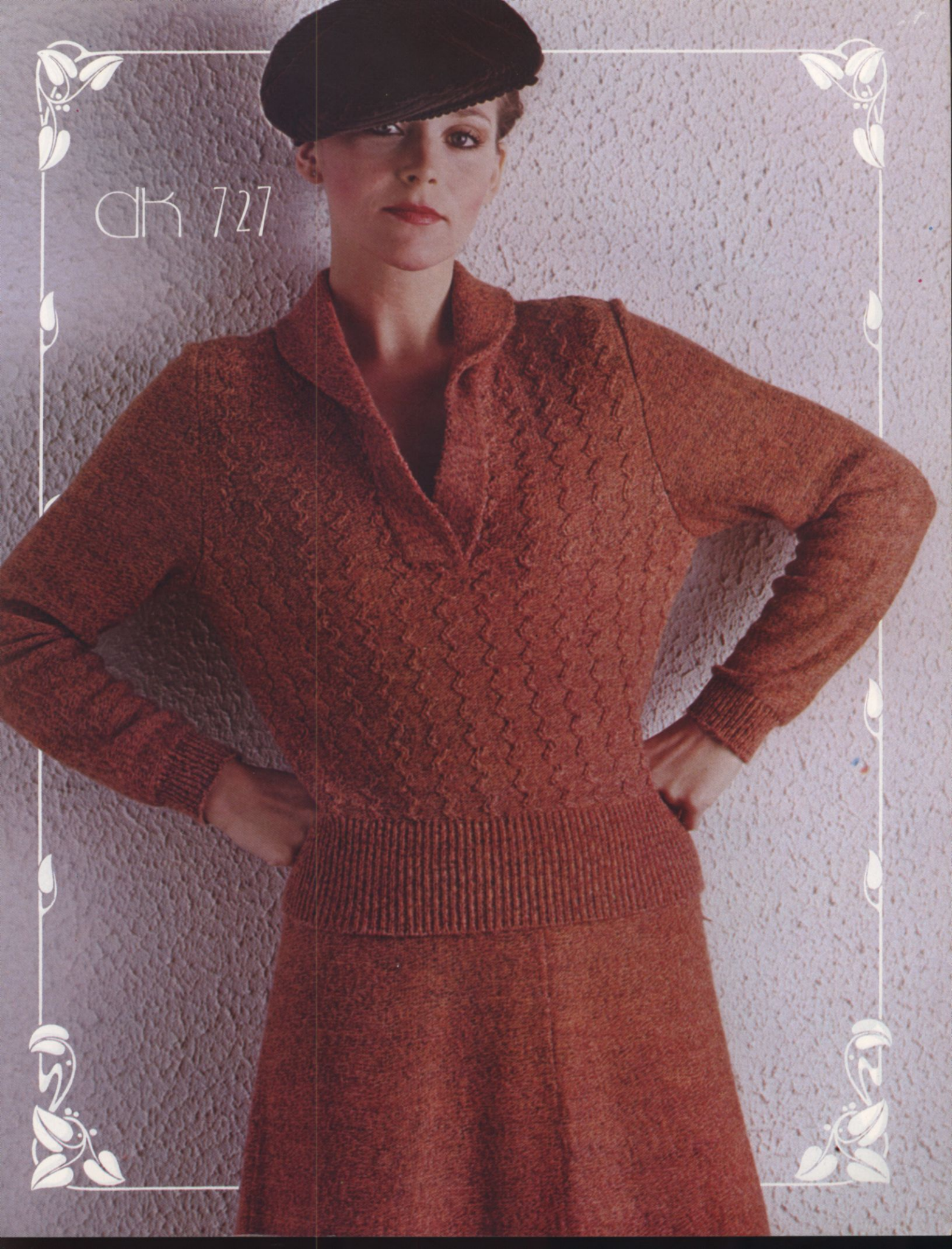



hp 133

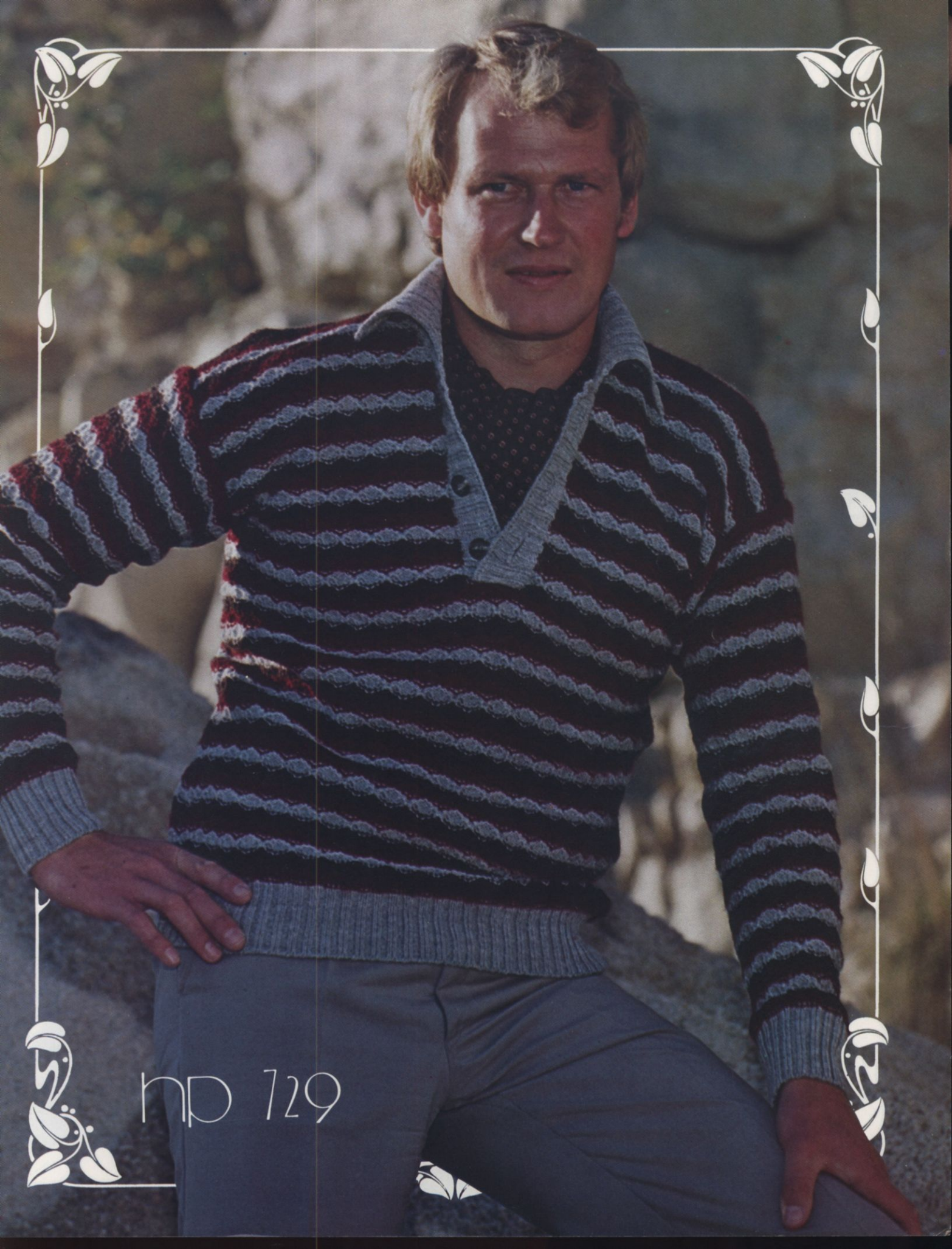

hp 729

dk 728



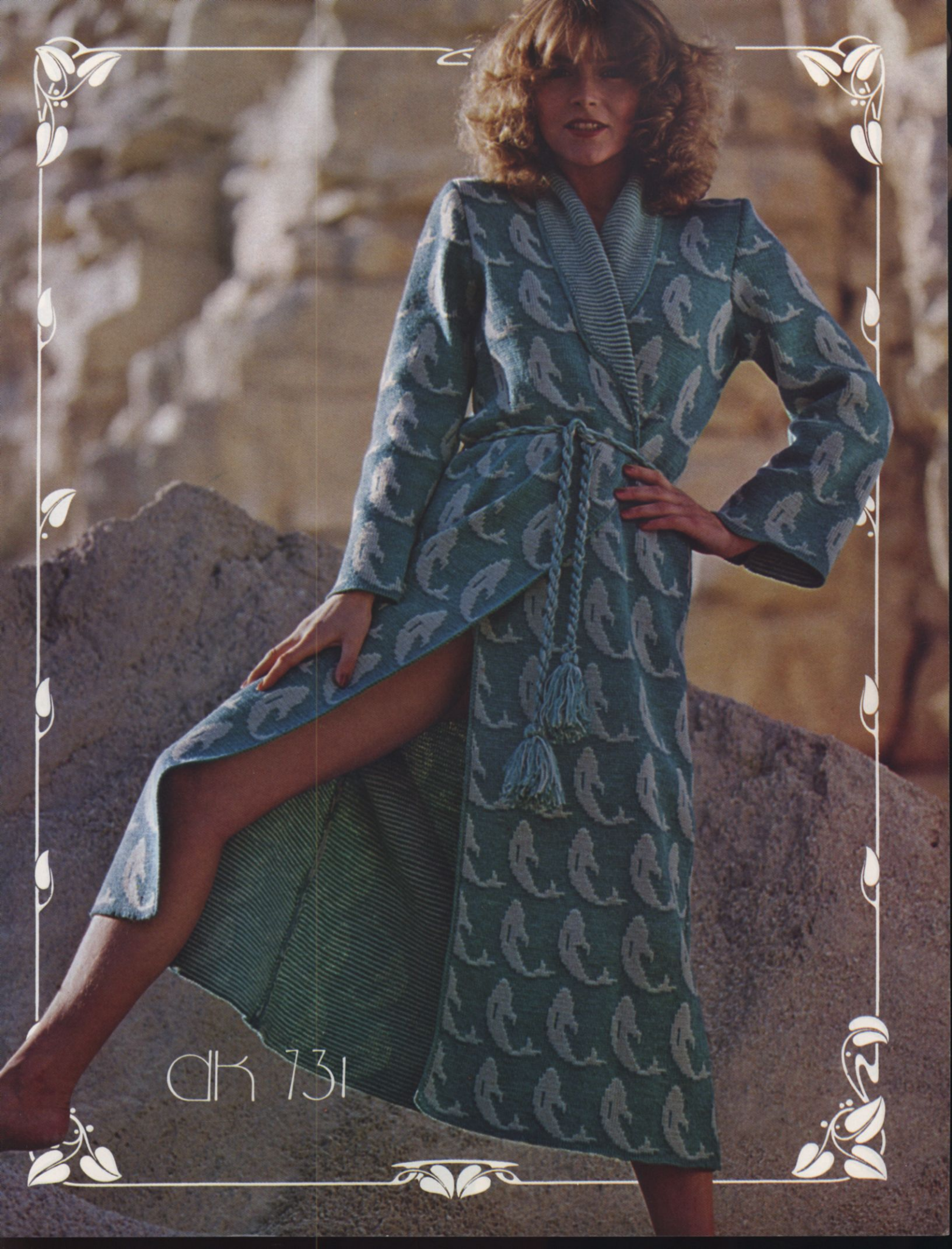

dk 731



dk 734

VOLUME 15, NO. 1

knitking

magazine

TABLE OF CONTENTS

PAGE NO.

DK 719	Woman's Jacket	14
DK 720	Woman's Pullover & Jacket	14
DK 721	Woman's Pullover	16
DK 722	Woman's Jacket & Skirt	17
DK 723	Woman's Fringed Jacket	19
DK 724	Woman's Pullover	20
HP 725	Man's Pullover	21
DK 726	Woman's Pullover & Skirt	22
DK 727	Woman's Two-Piece Dress	23
DK 728	Woman's Skirt, Vest & Tie	24
HP 729	Man's Pullover	25
DK 730	Woman's Two-Piece Suit	26
HP 732	Man's Cardigan	27
DK 731	Woman's Beach Robe	28
HP 733	Man's Sleeveless Pullover & Jacket	30
DK 734	Woman's Vest	31
KK 735	Child's Pants & Knee Socks	32
KK 736	Child's Pants & Socks	33
KK 737	Girl's Long Dress & Blouse	33
KK 738	Child's Pullover & Pants	36
KK 739	Girl's Skirt & Top	37
KK 740	Girl's Dress	37
KK 741	Child's Pants, Pullover & Cap	39

editorial

Importing companies such as ours suffer the ups and downs of U.S. Dollar valuation to the extent that it is possible to lose or gain several thousand dollars on a shipment during the few days of its journey to us... Many companies, unlike KNITKING, maintain a high resale price that protects them against inflation and gives them a greater profit margin when the value of the Dollar strengthens... We endeavor to operate on a steadily maintained profit margin irrespective of fluctuations and currency values... consequently, there are times when we can lower prices to our customers... A case in point is the greatly reduced prices of the EA 605 BABY LOCK and the 606 BLINDSTITCH advertised in this issue.. Because we made a volume purchase at the right time, both are available now at the lowest prices in several years.

NEW KH 840 KNITTER... We always believed the KH 830 to be the most versatile and easiest to use of all Punch Card Machines on the market and we thought that its efficiency would be difficult to improve upon... But, the technicians at BROTHER INDUSTRIES did just that and we now have the fabulous KH 840... A Brochure and Rebate Certificate is included in this issue for all U.S. subscribers.

KNITKING SEMINAR 1979 ... Every year, it gets bigger and better so plan to be with us for our SEMINAR starting October 8th and running through the 13th... You can depend on KNITKING to have a top team of experts lecturing and conducting classes... We will have some new products to show and all merchandise will be specially discounted.

We featured Carlos Arias for the first time two years ago when he started his own knitting business in the U.S. He is now nationally and internationally famous for his clever designs... He has three factories working at full pressure satisfying the demands of the countries foremost clothing stores... Popular, dynamic Carlos has promised to be with us again and to bring along some of his marvelous creations. You are sure to benefit from his great skills...

















Tami Nobuyuki, who writes the best 'How To' books for machine knitters will be with us again to demonstrate her proficiency and answer your questions... and of course, everybody at KNITKING will be ready to welcome you and satisfy your needs.

See the next issue of KNITKING MAGAZINE for more detailed information on our 79 SEMINAR...

Publisher: KNITKING CORPORATION, 1128 Crenshaw Blvd., Los Angeles, Calif. 90019. Telephone: (213) 938-2079. Published bi-monthly. Subscriptions: USA — \$15.00 annually, single copies \$4.00; Canada — \$18.00; other parts of the world — \$20.00. The entire contents of KNITKING MAGAZINE are copyright and must not be reproduced in any shape or form without the express permission, in writing of the publisher. © COPYRIGHT 1979 by KNITKING CORPORATION.

Pattern Symbols

Knitting – Chart Symbols

- () Size Symbols (2nd Size)
- < > 3rd Size
- ① Color Number
-  Cast on
-  Stitch
-  Row
-  Hem
-  Bind off
-  Stockinette stitch – worn on the Knit side.
-  Stockinette stitch – worn on the Purl side.
-  Knit 1, Purl 1 Ribbing
-  Ribbing Pattern – worn on the Knit side.
-  Ribbing Pattern – worn on the Purl side.
-  Closed Dart
-  Open Dart
-  Put on a stitch holder
-  Reverse 1 section
-  On every other needle
-  Number of Rows between Shapings. Make increase (or decrease) FIRST, then knit 4 rows. For example: 3 x 1  means decrease (or increase) 1 st., knit 4 rows; decrease 1 st., knit 4 rows; decrease 1 st., knit 4 rows; decrease 1 st., knit 4 rows. All decreasing (or increasing) without row numbers as shown must be shaped on every 2nd row.

 Increase

 Increase 2 sts. With a transfer tool, move the sts. over the left (or right) leaving 2 empty needles at the point of increase. At the increase point, move 1 st. to the left, (or right) so that there is an empty needles on each side of a stitch. On each side of the center stitch, pick up a stitch from the row below and hang it onto the empty needle.

 3 stitches on 1 needle. The 1st and 3rd stitch in a group of 3 has been hung on the 2nd or center needle.

 Short Row increase or decrease; for instance on a flared skirt knitted sideways.

 Pattern Stitch





 Pattern Stitch – worn on the Knit side.

 Pattern Stitch – worn on the Purl side.









 Repeat

- I = Front
- II = Back
- III = Sleeve
- IV = Skirt Front
- V = Skirt Back
- VI = Collar
- VII = Pocket
- VIII = Band
- IX = Belt
- X = Cuff
- XI = Pants Front
- XII = Pants Back

Finishing – Chart Symbols

-  Match numbers on section for assembling.
-  Ease
-  Fold Line
-  Turn to the wrong side and hem.

Stitch Symbols

-  Needles in holding position
-  Needles back into working position.
-  Empty needle (leave in working position)
-  Needle not used (in the out of work position).
-  Two stitches on 1 needle, either transferred from the right side or the left side, then put into holding position.
-  Needle holding 2 stitches. Stitch has been transferred from the RIGHT.
-  Needle holding 2 stitches. Stitch has been transferred from the LEFT.
-  Center of garment section



General Instructions

HOW TO READ THE CHARTS AND INSTRUCTIONS

There are 3 sizes given for each Pattern in KNITKING MAGAZINE. Above each Chart for the different sizes, you will see that the first and smaller sizes might be shown as 8/10, the second size as (12/14) and the third as [16/18]. Check the measurements at the bustline and hips on the Charts to be certain that you will knit the correct size, remembering these are ACTUAL measurements of the completed section and that there must be a bigger allowance at the bustline and hipline for a Jacket or a Coat than there would be for a fitted dress or a fitted blouse or pullover. The question in your mind should be "How do I want this garment to fit...?"

When you have chosen the size you need, you can follow the Charts as shown. You will notice that where the shapings are the same FOR ALL SIZES, only 1 set of shapings will be shown on the first Chart and if you are knitting the 2nd or 3rd size, you simply follow the shapings as given for the first size. If the shapings are different, this will be shown on the Charts and you should follow them as given.

On the Charts, increases and decreases will be shown as follows

5x1

6 The number in the box means number of ROWS between the shapings, while the 5x1 above the box means - 1 st. 5x... so you will increase or decrease 1 st. every 6th row 5x.

ARMHOLE SHAPINGS - NECK SHAPINGS - SHOULDER SHAPINGS - are made on every 2nd row UNLESS there is a number in a box along side or below the shapings. The rule is... where there is no box with a number, the shaping is made on every 2nd row.

THE PRINTED INSTRUCTIONS

You can follow the printed instructions or use them in combination with the Charts. Where there is any question in the printed instructions, you have the Charts to show you how the section will look.

The 3 sizes, with the different amounts of cast on stitches and the different shapings will look like this...

Cast on 124 (136) [148] sts. You will

Cast on 124 sts. for the first size.

Cast on 136 sts. for the 2nd size.

Cast on 148 sts. for the 3rd size.

The important thing to remember is that you MUST READ AHEAD so that you KNOW what to do for the size you are knitting. Sometimes where the number of stitches are the same but the number of times different, you will find shapings like this... 3 sts. 1x (2x) [3x], 2 sts. 1x (2x) [3x], 1 st. 3x (4x) [5x]. As you see, you MUST read ahead in order to follow the instructions as given for YOUR SIZE. The rows will be different for the different sizes in some cases... Shoulder and Neck shapings usually are worked at the SAME TIME for the back section - so watch for the words AT THE SAME TIME.

HOLDING STITCHES ON THE LEFT SIDE WHILE SHAPING THE RIGHT SIDE

When knitting a section of garment in stockinette stitch, it is easy to hold the stitches on the left side while knitting the right half, but when knitting a Pattern Stitch such as a Norwegian Design, a Holding Position Design, Weaving, etc., you should use the following method. For the NECK SHAPING, we tell you to bind off the center sts., put the needles on the left into holding position and complete the right half first... so with a strand of contrast yarn, knit ALL of the left side stitches manually by hand, pulling each stitch back against the needle bed to the OUT OF WORK position. When the right side is completed, carefully pull the stitches held on contrast, forward into working position and as you do so, undo the contrast yarn, line up the needles (KNITKING AM 3 machine owners, put the stitches under the sinkers) and complete the left half.

If you own a Japanese machine, you may find that when knitting the right half with the left side held in this way, the sinker plate will mark the left side while you are knitting the right half. To prevent this marking, you can tape a piece of paper over the knitting, underneath the sinkers, or if you own a Reversing Bar, you can hang this onto the Sinkers while you are knitting the right half. When hanging the Reversing Bar, be sure the eyes of the bar go BETWEEN the Sinker Posts on the upper part of the bar so that the tips of the bar only - show above the needle bed.

FULL FASHION DECREASING OR INCREASING

For Stockinette stitch, always use the Full Fashion method for increasing or decreasing.

TO DECREASE: Hang the 3rd stitch onto the 2nd stitch then move the stitches in to fill the empty needle.

TO INCREASE: Move the 2 end stitches 1 needle outward, then pick up the 3rd stitch from the row below and hang it onto the empty needle.

FINISHING: Block all sections. For PULLOVERS, JACKETS, and DRESSES: Join front to back at sides and shoulders. Sew sleeves together and set in. Hem lower edge and sleeve edges if needed. For a double neckband or armhole band, sew 1 edge to the inside and 1 to the outside of neck or armhole. For a single ribbed band, sew 1 edge to the outside of neck or armhole edge. For a cardigan or jacket with buttonholes, finish buttonholes and sew on buttons.

PANTS: Join front to back at sides. Sew inside leg seams, then join center front and back. Make hem at waistline and insert elastic. Hem lower edge of pants legs.

THE SAMPLE SWATCH

Before you begin to knit any garment, you will need to knit a sample piece using the yarn you have chosen for your garment, so that you can check the stitch and row gauge which must measure the correct number of stitches and rows in 5 cm (2 inches).

For each Pattern in KNITKING MAGAZINE, we give you 3 tension numbers to work from and if you use the specified yarn for the garment, you should be able to get the correct stitch and row gauge using one of these numbers. Here is a very easy way to make your sample swatch and count the stitches and rows without actually counting, by using our KNITKING Converta Tape.

Supposing the Tension Numbers for the Stitch and Row Gauge are given as 5 to 7. Set the Tension Dial to the first number which is 5. With contrast waste yarn, and using the quick cast on method, cast on 60 stitches and knit 10 rows. Change to garment yarn and turn the Row Counter to 0. Knit 30 rows. Counting from each end, knit the 10th stitch on each side by hand with a small piece of contrast yarn. Leave the needles in working position and knit 30 rows (Row 60), then knit 4 rows with contrast waste yarn. Turn the Row Counter to 0 and the Tension Dial to 6 and with garment yarn, knit 30 rows. Mark the 10th stitch on each side as you did before, knit 30 rows, then 4 rows with contrast waste yarn. Turn the Row Counter to 0 and with Tension 7, repeat the above once more, ending with 10 rows of contrast waste yarn. Remove the work from the machine by passing the Slide across the needles without yarn (sometimes called 'dropping').

Pull and stretch the sample piece both lengthwise and diagonally from corner to corner, then lengthwise again. Do not count the stitches and rows immediately, but allow the sample to rest for several hours or even over night. This will allow the stitches and rows to return to their basic form.

When your sample has rested and you are ready to count the stitches and rows, the KNITKING CONVERTA TAPE will do the counting for you without any counting on your part. Use the Tape as follows:

Measure the stitches with the TAPE, BETWEEN the 40 stitches marked with contrast waste yarn. Push the SLIDE so that the LEFT EDGE lines up to this exact measurement. Now look down along side the SLIDE and find the number 40 on the TAPE. The number directly opposite on the SLIDE will be your Stitch Gauge to 5 cm (2"). To find the number of rows in 5 cm (2"), place the TAPE to measure over the 60 rows, push the SLIDE to this number with the left edge lined up, the look for the number 60 on the TAPE and directly opposite this will be the number of rows to 5 cm (2")

If you do not own a KNITKING CONVERTA TAPE, you must mark a 5 cm (2 inch) square in the center of the knitting, then count the number of stitches and rows within the square.

dk 719

WOMAN'S JACKET

SIZES: 8/10 (12) [14/16]
 YARN: Crocus Crepe
 GRAMS: 600 650 700
 TENSION: 8 to 10
 GAUGE: Pattern, OVER EVERY OTHER NEEDLE - 8 sts. 25 rows = 5 cm

A Tuck Stitch Pattern over every other needle. Punch your own Card. The bands are ribbed.

FINISHING: See General Instructions. After sewing the shoulder seams, Pick up sts. along 1 front edge around to center of back - EVERY OTHER NEEDLE. Work 12 rows in Tuck Pattern. To bind off, put the first stitch onto 2nd needle and pull through 2nd st, bind off and continue in this way until all sts. are bound off. Repeat for other side. Sew center back seam of band, then work 1 row REVERSE single crochet around edges of band. Make a cord using 6 strands of yarn then pull through first pattern row at waist and tie.

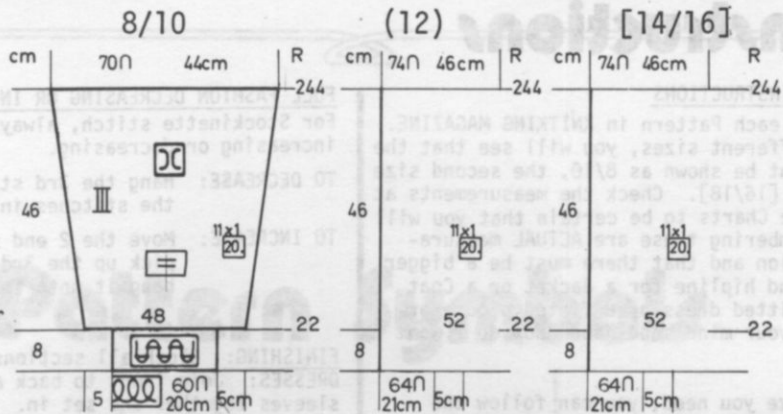

SLEEVES: III

Cast on 60 (64) [64] sts. and work 22 rows K1, P1 Ribbing. Transfer the ribber sts. and DECREASE 12 sts. evenly across and SET FOR PATTERN same as you did for the back using every other needle. ON EACH SIDE, increase 1 st. every 20th row 11x. After Row 244, bind off.

FRONT: I Make 1, reverse I

Cast on 80 (84) [86] sts. and work 30 rows K1, P1 Ribbing. Transfer the ribber sts. then DECREASE 40 (41) [41] sts. evenly across and set up for Pattern same as you did for Back over EVERY OTHER NEEDLE. ON FRONT EDGE, decrease 1 st. every 17th row 14x. (every 16th row 15x). [every 16th row 15x]. After Row 154, mark side ed. for setting in sleeve then Knit to Row 261 (261) [265] SHAPE SHOULDER, bind off 5 sts. 4x, 6 sts. 1x. (5 sts. 4x, 8 sts. 1x). [6 sts. 5x].

FRONT & NECK BANDS, See FINISHING INSTRUCTIONS.

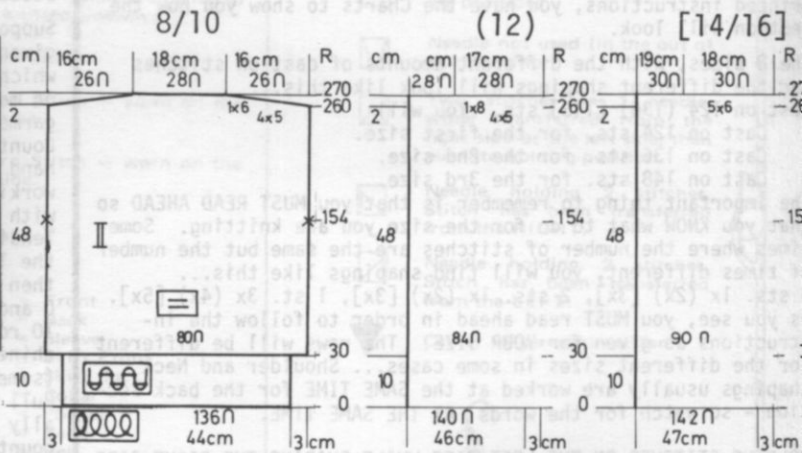
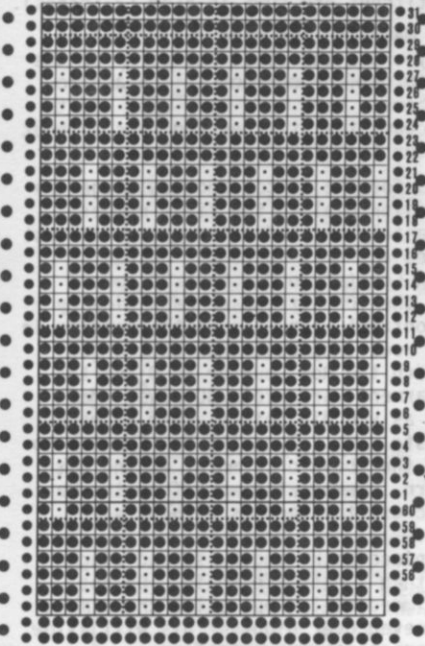
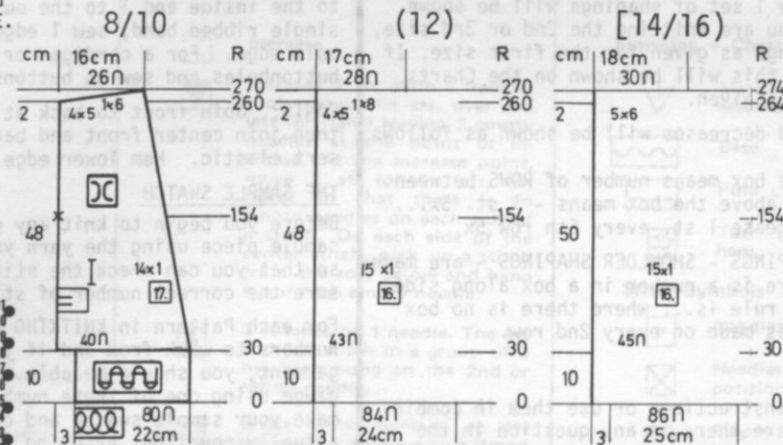

BACK: II

Cast on 136 (140) [142] sts. and work 30 rows K1, P1 Ribbing. Transfer the ribber sts. to main machine then DECREASE 56 (56) [52] sts. across and set for PATTERN USING EVERY OTHER NEEDLE - Always be sure to use the FIRST NEEDLE TO THE LEFT OF 0 then every other needle on each side.

Continue in Pattern. Mark Row 154 for setting in sleeve then knit to Row 260. SHAPE SHOULDER: ON EACH SIDE, bind off 5 sts. 4x, 6 sts. 1x. (5 sts. 4x, 8 sts. 1x). [6 sts. 5x]. After Row 270, bind off the remaining sts.

dk 720

WOMAN'S PULLOVER & JACKET

SIZES: 8/10 (12/14) [16]
 YARN: Crocus Crepe
 GRAMS: color 1 750 800 850 color 2 400 450 500
 TENSION: 8 to 10
 GAUGE: 14 sts. 13 rows = 5 cm (2")

A Norwegian Design using two Cards. Be sure to reverse the Cards when knitting the second half of fronts and the second sleeve. The bands are ribbed.



FINISHING: See General Instructions. Finish Buttonholes & sew on Buttons.

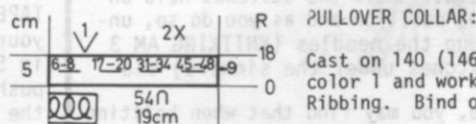

PULLOVER COLLAR:

Cast on 140 (146) [152] sts. with color 1 and work 40 rows K1, P1 Ribbing. Bind off.

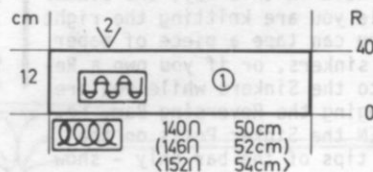

PULLOVER FRONT BANDS: Make 2.

Cast on 54 sts. with color 1 and work K1, P1 Ribbing. After Row 9, make BUTTONHOLES over needles 6 to 8, 17 to 20, 31 to 34, 45 to 48. After Row 18, bind off. Work the 2nd band the same but OMitting Buttonholes.

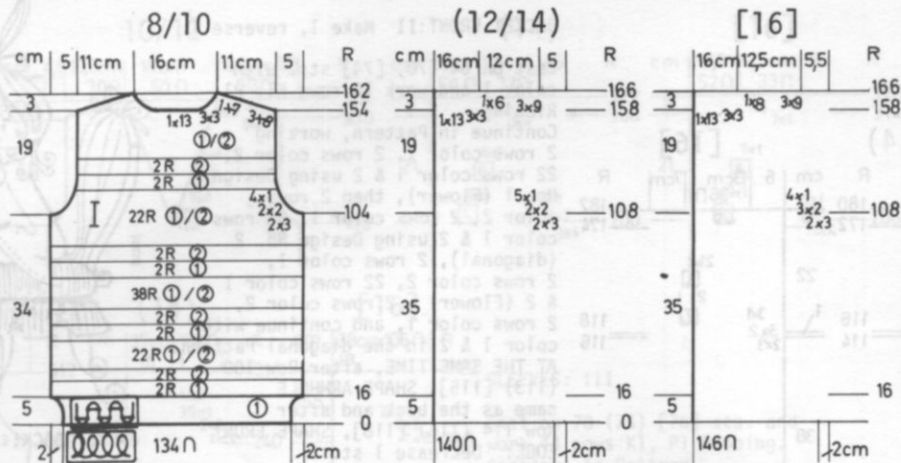

PULLOVER BACK: I
 Cast on 134 (140) [146] sts. with color 1 and work 16 rows K1, P1 Ribbing.
 Continue in Pattern. Work 2 rows color 1, 2 rows color 2 then 22 rows Norwegian Design 1 (Flower), 2 rows color 1, 2 rows color 2, 38 rows Norwegian Design 2 (Diagonal) etc.. Follow the Chart for Pattern and color remembering that 22 rows are always Design No. 1 (flower) and the 38 rows Design No. 2 (diagonal).
 After Row 104 (108) [108], SHAPE ARMHOLE: ON EACH SIDE, bind off 3 sts. 2x, 2 sts. 2x, 1 st. 4x. (3 sts. 2x, 2 sts. 2x, 1 st. 5x). [3 sts. 2x, 2 sts. 3x, 1 st. 4x].
 After Row 154 (158) [158], SHAPE SHOULDER AND NECK AT THE SAME TIME.

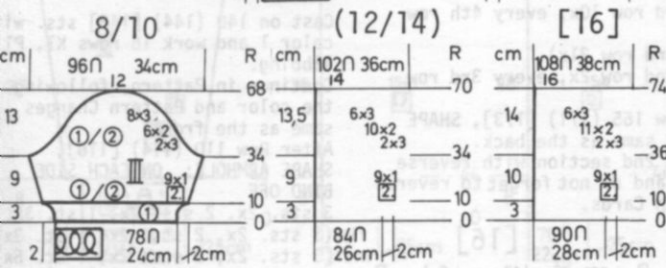

PULLOVER SLEEVES: III
 Cast on 78 (84) [90] sts. with color 1 and work 10 rows K1, P1 Ribbing.
 Continue in the Diagonal Pattern.
 ON EACH SIDE, increase 1 st. every 2nd row 9x.
 After Row 34 (34) [36], SHAPE CAP: ON EACH SIDE, bind off 3 sts. 2x, 2 sts. 6x, 3 sts. 8x. (3 sts. 2x, 2 sts. 10x, 3 sts. 6x). [3 sts. 2x, 2 sts. 11x, 3 sts. 6x].
 After Row 68 (70) [74], bind off the remaining sts.

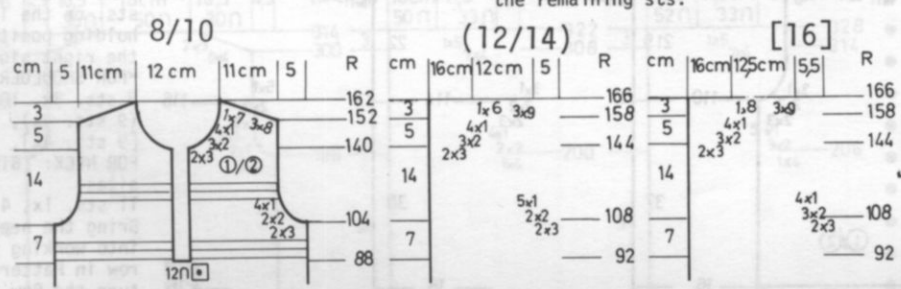

PULLOVER FRONT: II
 Work the front the same as the back, following the same pattern sequence throughout.
 After Row 88 (92) [92], bind off the center 12 sts., put the needles on the left into holding position and complete the right side first.
 *Knit to Row 104 (108) [108]. SHAPE ARMHOLE same as the back then knit to Row 141 (145) [145].
 SHAPE NECK: Bind off 3 sts. 2x, 2 sts. 3x, 1 st. 4x for all sizes.
 After Row 152 (158) [158], SHAPE SHOULDER same as the back. Bring the needles on the left into working position, knit 1 row in Pattern to the left side, turn the Row Counter back to 88 (92) [92] and complete the left half. Follow the instructions from *.

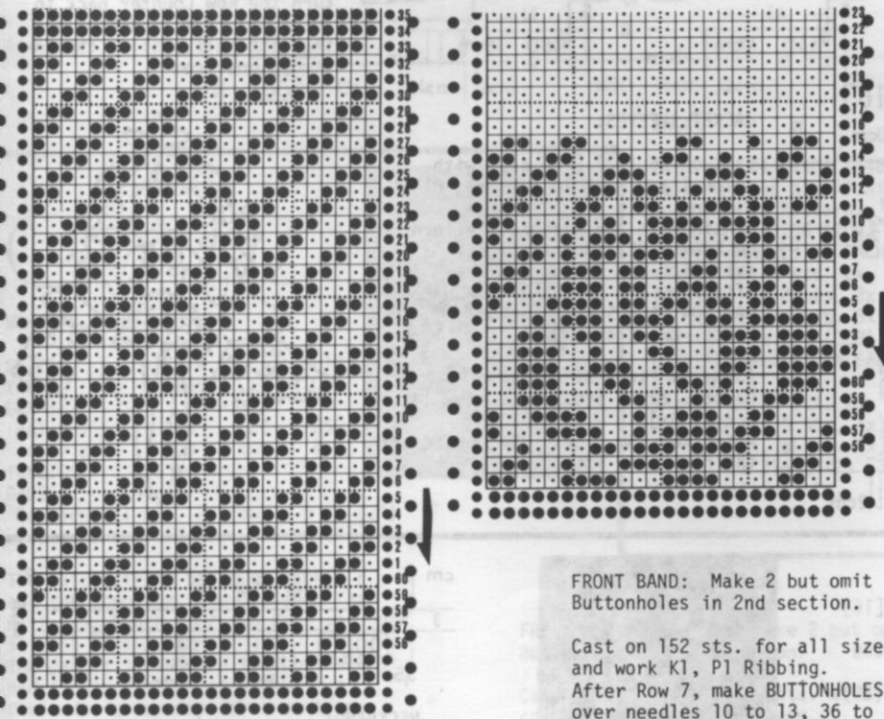

COLLAR: Make 1, reverse 1.

Cast on 96, (100) [104] and work K1, P1 Ribbing.
 After Row 14, work SHORT ROWS.
 ON OPPOSITE SIDE OF SLIDE, put into holding position
 3 sts. 12x, 4 sts. 6x.
 (3 sts. 12x, 4 sts. 7x).
 [3 sts. 12x, 4 sts. 8x].
 After Row 50 (52) [54], bind off.

FRONT BAND: Make 2 but omit Buttonholes in 2nd section.

Cast on 152 sts. for all sizes and work K1, P1 Ribbing.
 After Row 7, make BUTTONHOLES over needles 10 to 13, 36 to 39, 62 to 65, 88 to 91, 113 to 116, 131 to 135 counting from the left edge. Knit to Row 14, then bind off.

Sew Collar sections together at back, then sew narrow ends to bands.
 Sew in place on Jacket.



dk 720

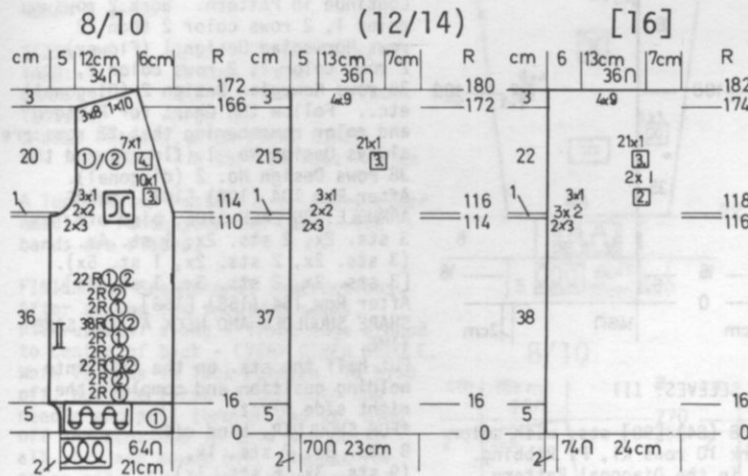

JACKET FRONT: I Make 1, reverse 1.

Cast on 64 (70) [74] sts. with color 1 and work 16 rows K1, P1 Ribbing.
Continue in Pattern, working 2 rows color 1, 2 rows color 2, 22 rows color 1 & 2 using Design No. 1 (Flower), then 2 rows color 2, 2 rows color 1, 38 rows color 1 & 2 using Design No. 2 (diagonal), 2 rows color 1, 2 rows color 2, 22 rows color 1 & 2 (Flower), 2 rows color 2, 2 rows color 1, and continue with color 1 & 2 in the diagonal Pattern.
AT THE SAME TIME, after Row 109 (113) [115], SHAPE ARMHOLE same as the back and after Row 114 (116) [118], SHAPE FRONT EDGE: Decrease 1 st. every 3rd row 10x, every 4th row 7x.
(every 3rd row 21x).
[every 2nd row 2x, every 3rd row 21x].
After Row 165 (171) [173], SHAPE SHOULDER same as the back.
Make the 2nd section with reverse shaping and do not forget to reverse the Punch Cards.



JACKET BACK: I

Cast on 140 (144) [148] sts. with color 1 and work 16 rows K1, P1 Ribbing.
Continue in Pattern, following the color and Pattern Changes same as the front.
After Row 110 (114) [116], SHAPE ARMHOLE: ON EACH SIDE BIND OFF 3 sts. 2x, 2 sts. 2x, 1 st. 3x (3 sts. 2x, 2 sts. 2x, 1 st. 3x) [3 sts. 2x, 2 sts. 2x, 1 st. 5x] Knit to Row 166 (172) [174]. SHAPE SHOULDER AND NECK AT THE SAME TIME. Put half the sts. on the left side into holding position and complete the right side first.
*FOR SHOULDER, bind off 8 sts. 3x, 10 sts. 1x, (9 sts. 4x), [9 sts. 4x],
FOR NECK: Bind off for all sizes.
11 sts. 1x, 4 sts. 3x.
Bring the needles on the left into working position, knit 1 row in Pattern to the left side turn the Row Counter back to 166 (172) [174] and complete the left half. Follow the instructions from *.

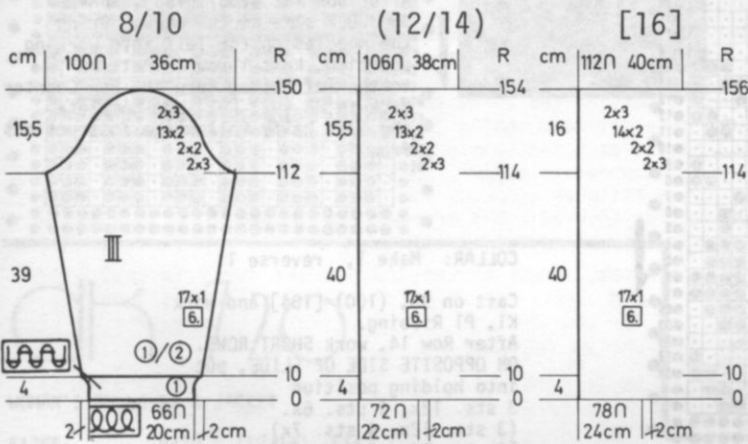
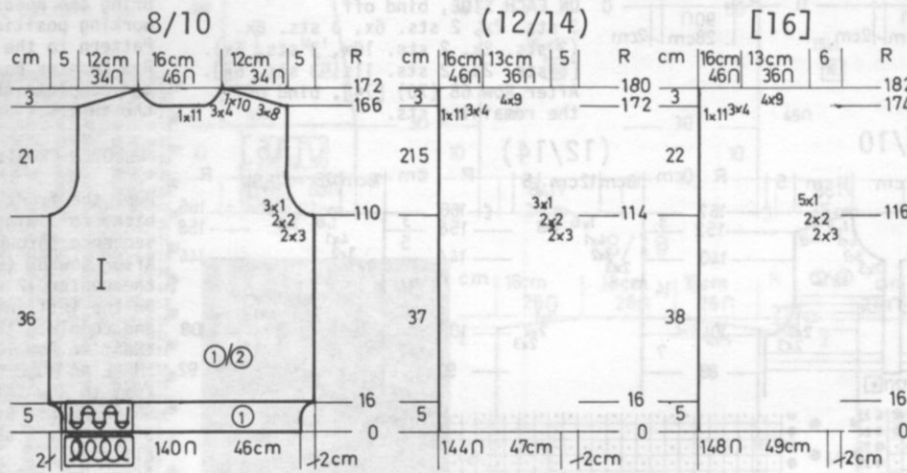

JACKET SLEEVES:

Cast on 66 (72) [78] sts. with color 1 and work 10 rows K1, P1 Ribbing.
Continue in the Diagonal Pattern. ON EACH SIDE, increase 1 st. every 6th row 17x.
After Row 112 (114) [114], SHAPE CAP: ON EACH SIDE, bind off 3 sts. 2x, 2 sts. 2x, 2 sts. 13x, 3 sts. 2x.
(Same as first size).
[3 sts. 2x, 2 sts. 2x, 2 sts. 14x, 2 sts. 3x].
After Row 150 (154) [156], bind off the remaining sts.



dk 721

WOMAN'S PULLOVER

SIZES: 10/12 (14) [16]
YARN: Fortissima
GRAMS: 400 450 500
TENSION: 6 to 8
GAUGE: 14 sts. 26 rows = 5 cm (2").

A Tuck Stitch Pattern worn on the Purl side. Punch your own Card and push in BOTH TUCK BUTTONS. Bands are ribbed.

FINISHING: See General Instructions.

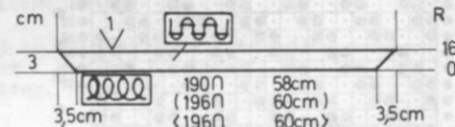

NECKBAND:

Cast on 190 (196) [196] sts. and work K1, P1 Ribbing. ON EACH SIDE, increase 2 sts. every 2nd row 7x.
After Row 16, bind off.

10/12

(14)

[16]

FRONT: II

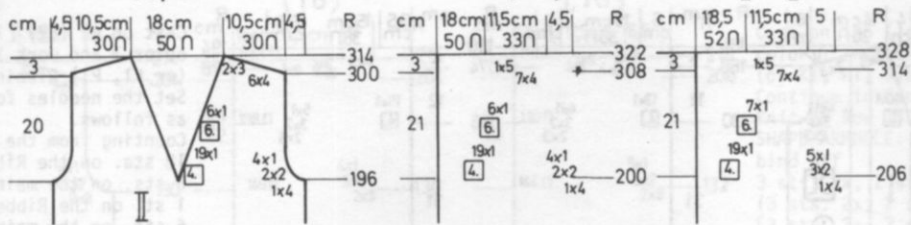

Work the front the same as the back to Row 196 (200) [206]. Divide in the center, put the needles on the left into holding position and complete the right side first. *SHAPE ARMHOLE SAME AS THE BACK, but at the SAME TIME, SHAPE NECK. ON NECK SIDE, bind off 1 st. every 4th row 19x, every 6th row 6x. (Same as first size). [1 st. every 4th row 19x, every 6th row 7x]. After Row 300 (308) [314], SHAPE SHOULDER same as the back. Bring the needles on the left into working position, knit 1 row in Pattern to the left side, turn the Row Counter back to 196 (200) [206] and complete the left half. Follow the instructions from *.

10/12

(14)

[16]

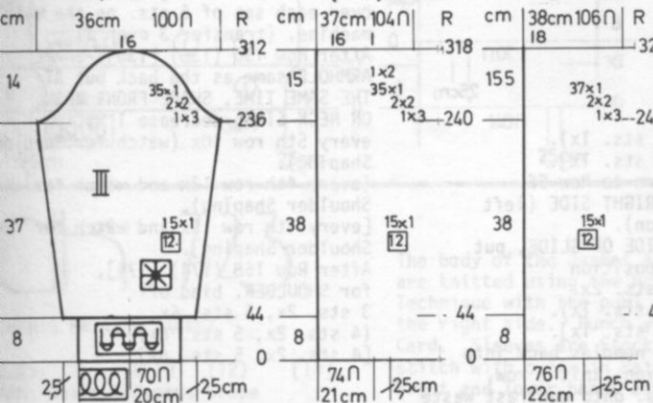

SLEEVES: III

Cast on 70 (74) [76] sts. and work 44 rows K1, P1 Ribbing. Continue in Pattern. ON EACH SIDE, increase 1 st. every 12th row 15x for all sizes. After Row 236 (240) [240], SHAPE CAP: ON EACH SIDE, bind off 3 sts. 1x, 2 sts. 2x, 1 st. 35x. (3 sts. 1x, 2 sts. 2x, 1 st. 35x, 2 sts. 1x). [3 sts. 1x, 2 sts. 2x, 1 st. 37x]. After Row 312 (318) [320], bind off the remaining sts.

10/12

(14)

[16]

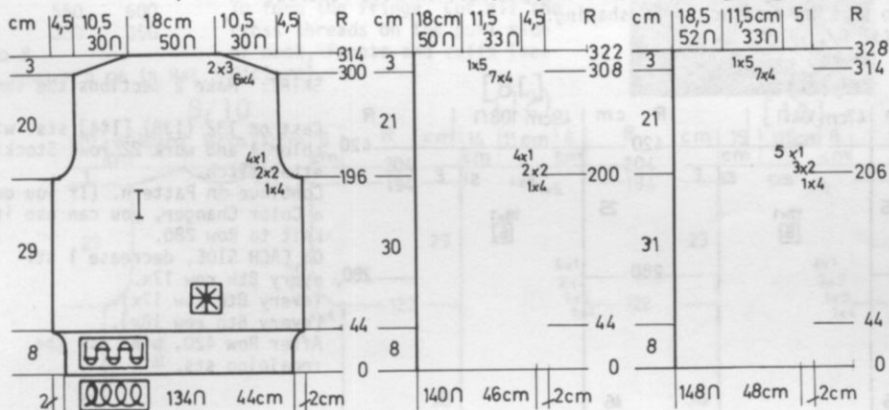

BACK: I

Cast on 134 (140) [148] sts. and work 44 rows K1, P1 Ribbing. Continue in Pattern. Knit to Row 196 (200) [206]. SHAPE ARMHOLE: ON EACH SIDE, bind off 4 sts. 1x, 2 sts. 2x, 1 st. 4x. (4 sts. 1x, 2 sts. 2x, 1 st. 4x). [4 sts. 1x, 2 sts. 3x, 1 st. 5x]. Knit to Row 300 (308) [314]. SHAPE SHOULDER: ON EACH SIDE, bind off 4 sts. 6x, 3 sts. 2x. (4 sts. 7x, 5 sts. 1x). [4 sts. 7x, 5 sts. 1x]. After Row 314 (322) [328], bind off the remaining sts.

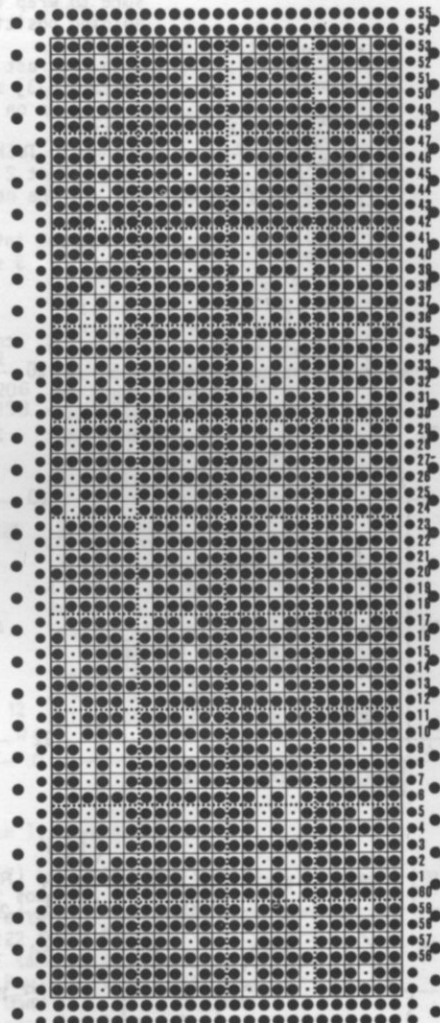

dk 722

WOMAN'S JACKET & SKIRT

SIZES: 12/14 (16) [18]
 YARN: Vienna
 GRAMS: color 1 600 600 650
 color 2 400 400 450
 TENSION: 6 to 8
 GAUGE:



Pattern: 11 sts. 28 rows = 5 cm (2")
 Stock: 13 sts. 17 rows = 5 cm (2")

The Skirt, front bands of Jacket and the shoulder trim are in a Tuck Pattern. Punch your own Card and push in both Tuck Buttons.

The Jacket is worn on the purl side and is Stockinette stitch with a Cable design on the front sections. Bands are K2, P2 (or K1, P1) Ribbing.

FINISHING: See General Instructions. Sew Shoulder Trim in place on the front sections before putting jacket together. Finish Buttonholes and sew on Buttons.

FRONT AND NECK BAND: Make 2 but omit Buttonholes in 2nd section.

Cast on 160 (164) [166] sts. with color 1 and work in Pattern. After Row 20, work Buttonholes over needles 5 to 7, 33 to 35, 61 to 63, 89 to 91. After Row 40, bind off.



dk 722

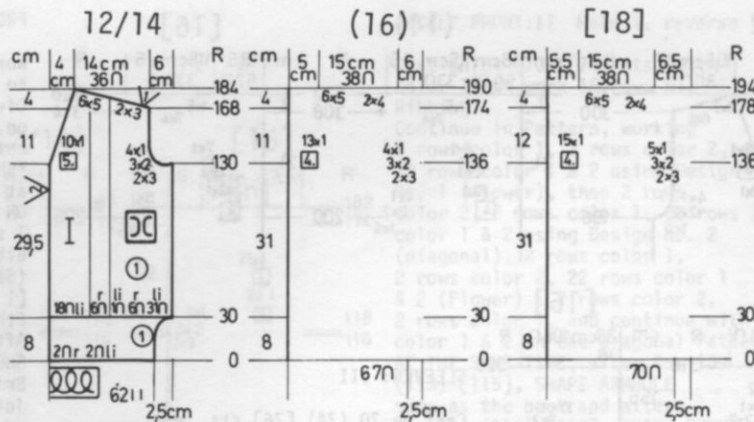

JACKET FRONT: I Make 1, reverse 1

Cast on 62 (67) [70] sts. with color 1 and work 30 rows K2, P2 (or K1, P1) Ribbing. Set the needles for Cable Pattern as follows. Counting from the Left edge, 18 sts. on the Ribber, 6 sts. on the main machine, 1 st. on the Ribber. 6 sts. on the main machine, 31 sts. on the Ribber. After every 8th row, Make Cables over each set of 6 sts. on the main machine. (transfer 3 over 3). After Row 130 (136) [136], SHAPE ARMHOLE same as the back but AT THE SAME TIME, SHAPE FRONT NECK. ON NECK SIDE, decrease 1 st. every 5th row 10x (watch for Shoulder Shaping). (every 4th row 13x and watch for Shoulder Shaping). [every 4th row 15x and watch for Shoulder Shaping]. After Row 168 (174) [178], for SHOULDER, bind off 3 sts. 2x, 5 sts. 6x. (4 sts. 2x, 5 sts. 6x). [4 sts. 2x, 5 sts. 6x].

SHOULDER TRIM: Make 1, reverse 1.

The shoulder trim is worked in TUCK PATTERN using SHORT ROWS. Always be sure to wrap the inside needle in holding position to prevent a hole.

(4 sts. 6x, 7 sts. 1x).
 [5 sts. 6x, 3 sts. 1x].
 Knit in Pattern to Row 56. Slide on the RIGHT SIDE (left for 2nd section). ON OPPOSITE SIDE OF SLIDE, put into holding position 5 sts. 4x, 4 sts. 2x. (5 sts. 5x, 6 sts. 1x). [6 sts. 5x, 3 sts. 1x]. Bring all the needles back into working position, knit 1 row. Remove the sts. onto contrast waste yarn. Work the 2nd section with reverse shaping.

With contrast waste yarn, cast on 28 (31) [33] sts. Knit 9 rows, ending with Slide on the LEFT (right for 2nd section). Change to TUCK PATTERN and garment yarn. Knit 2 rows. Put all the needles into holding position. Bring back into working position 2 sts. 5x, 3 sts. 6x.

REVERSE I

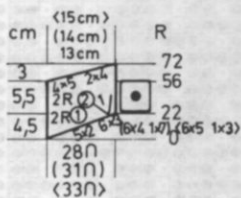

SKIRT: Make 2 sections the same.

Cast on 132 (138) [144] sts. with color 1 and work 22 rows Stockinette stitch. Continue in Pattern. (If you own a Color Changer, you can use it). Knit to Row 280. ON EACH SIDE, decrease 1 st. every 8th row 17x. (every 8th row 17x). [every 6th row 18x]. After Row 420, bind off the remaining sts.

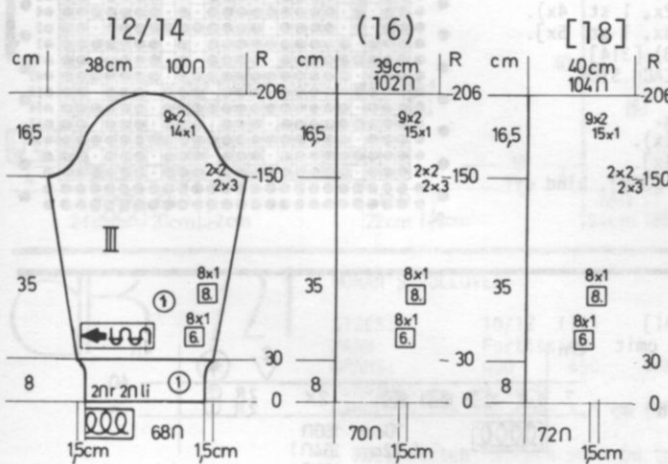
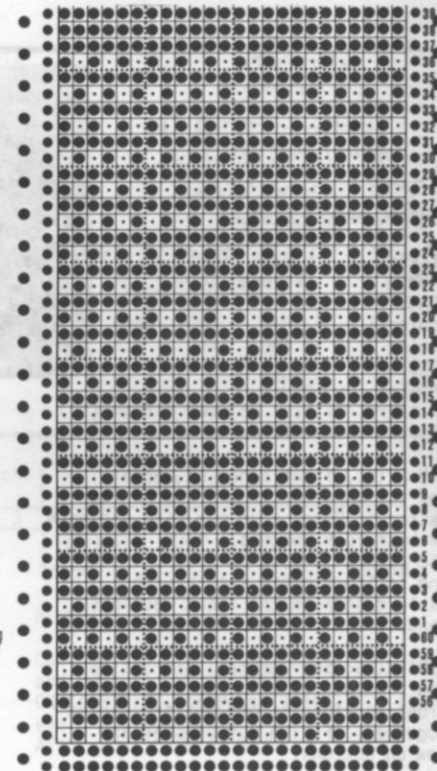
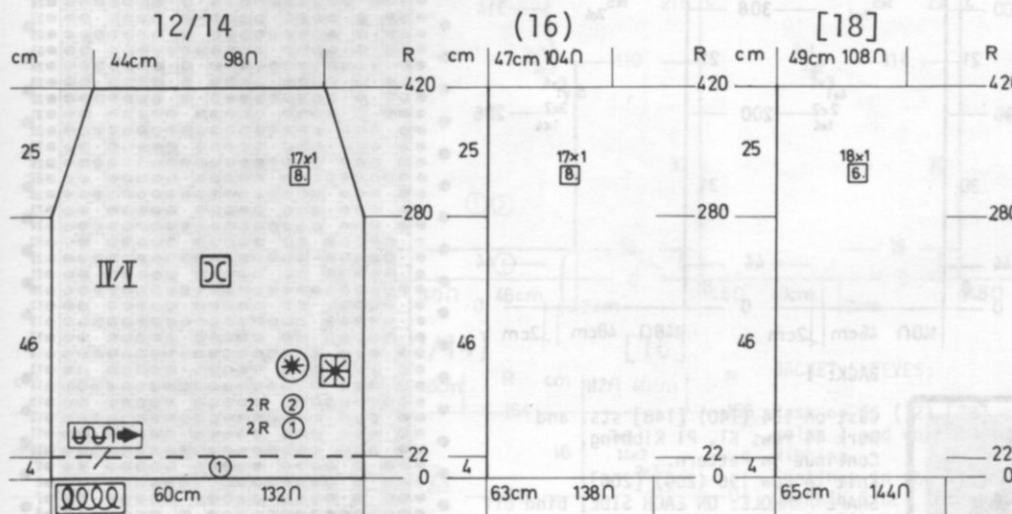

SLEEVES: III
 Cast on 68 (70) [72] sts. with color 1 and work 30 rows K2, P2 (or K1, P1) Ribbing. Continue in Stockinette stitch with color 1. ON EACH SIDE, increase 1 st. every 6th row 8x, every 8th row 8x for all sizes. After Row 150, SHAPE CAP: ON EACH SIDE, bind off 3 sts. 2x, 2 sts. 2x, 1 st. 14x, 2 sts. 9x. (3 sts. 2x, 2 sts. 2x, 1 st. 15x, 2 sts. 9x). [3 sts. 2x, 2 sts. 2x, 1 st. 15x, 2 sts. 9x]. After Row 206, bind off the remaining sts.



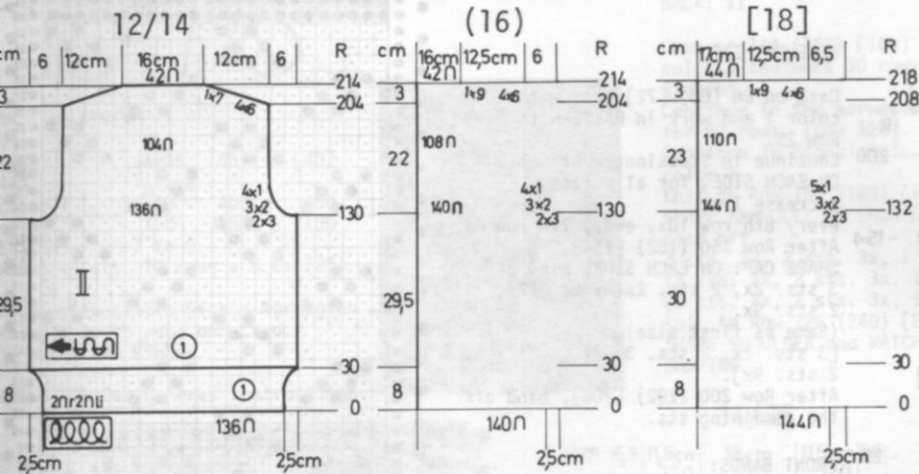

JACKET BACK: II

Cast on 136 (140) [144] sts. with color 1 and work 30 rows K2, P2 (or K1, P1) Ribbing. Continue in Stockinette stitch. Knit to Row 130 (130) [132]. SHAPE ARMHOLE: ON EACH SIDE, bind off 3 sts. 2x, 2 sts. 3x, 1 st. 4x. (3 sts. 2x, 2 sts. 3x, 1 st. 4x). [3 sts. 2x, 2 sts. 3x, 1 st. 5x]. Knit to Row 204 (204) [208]. SHAPE SHOULDER: ON EACH SIDE, bind off 6 sts. 4x, 7 sts. 1x. (6 sts. 4x, 9 sts. 1x). [6 sts. 4x, 9 sts. 1x]. After Row 214 (214) [218], bind off the remaining sts.

723

WOMAN'S FRINGED JACKET

SIZES: 8/10 (12) [14]
 YARN: Color 1-Crocus Crepe
 Color 2-Euro Sport
 QUANTITIES:
 Color 1 500 550 600
 Color 2 300 350 350
 TENSION: 6 to 8
 GAUGE: 13 sts. 16 rows = 5 cm in Pat.

The body of the Jacket and Collar are knitted using the Norwegian Technique with the purl side as the right side. Punch your own Card. Sleeves are Stockinette stitch with cuffs in Pattern. Front and lower bands are Ribbed.

FINISHING: See General Instructions. To form the fringe, Cut all the cross threads on the purl side of back, fronts and cuffs (see Picture).



BACK: II

Cast on 120 (126) [130] sts. with color 1 and work 12 rows K1, P1 Ribbing. Continue in Pattern. Knit to Row 122 (122) [126]. SHAPE ARMHOLE: ON EACH SIDE, bind off 4 sts. 1x, 3 sts. 1x, 2 sts. 2x, 1 st. 4x. (4 sts. 1x, 3 sts. 1x, 2 sts. 2x, 1 st. 4x). [4 sts. 1x, 3 sts. 1x, 2 sts. 2x, 1 st. 4x]. Knit to Row 194 (194) [198]. Put half the sts. on the left into holding position and complete the right side first. *SHAPE SHOULDER AND NECK AT THE SAME TIME. FOR SHOULDER, bind off 6 sts. 1x, 5 sts. 4x, (5 sts. 1x, 6 sts. 4x), [6 sts. 5x]. FOR NECK on all sizes, bind off 12 (12) [13] sts. 1x, then 4 sts. 1x, 3 sts. 1x. Bring the needles on the left into working position, knit 1 row in Pattern to the left side, turn the Row Counter back to 194 (194) [198] and complete the left half. Follow the instructions from *.

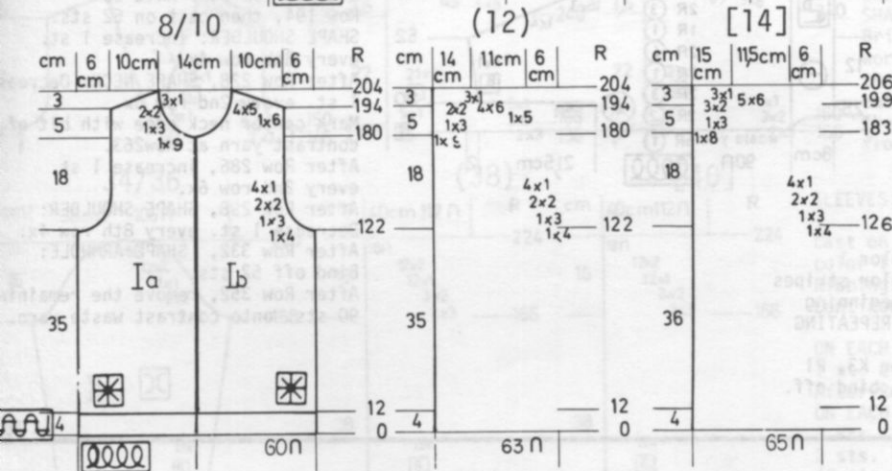
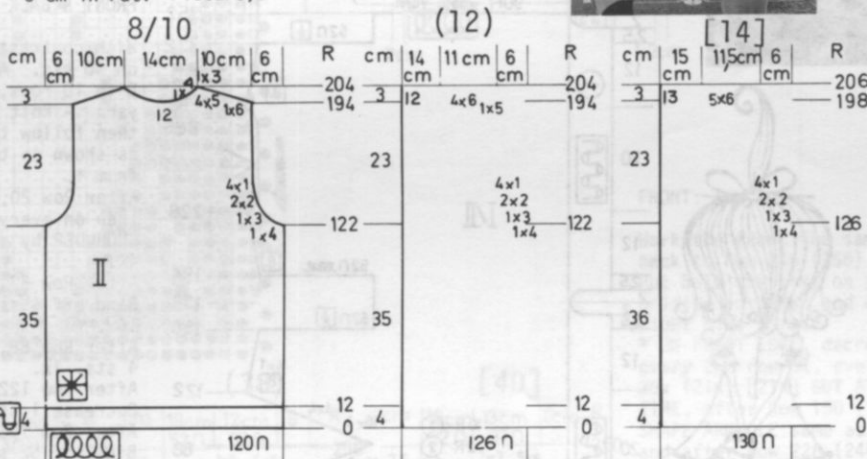

FRONT: I Make 1, reverse 1.

Cast on 60 (62) [65] sts. with color 1 and work 12 rows K1, P1 Ribbing. Continue in Pattern. Knit to Row 122 (122) [126]. SHAPE ARMHOLE same as the back, then knit to Row 179 (179) [183]. SHAPE NECK: Bind off 9 sts. 1x, 3 sts. 1x, 2 sts. 2x, 1 st. 3x. (9 sts. 1x, 3 sts. 1x, 2 sts. 2x, 1 st. 3x). [8 sts. 1x, 3 sts. 1x, 2 sts. 3x, 1 st. 3x]. After Row 194 (194) [198], SHAPE SHOULDER same as the back.

COLLAR: Make 2 pieces.

Cast on 70 (75) [75] sts. with color 1 and work in Pattern to Row 50. Bind off



dk 723

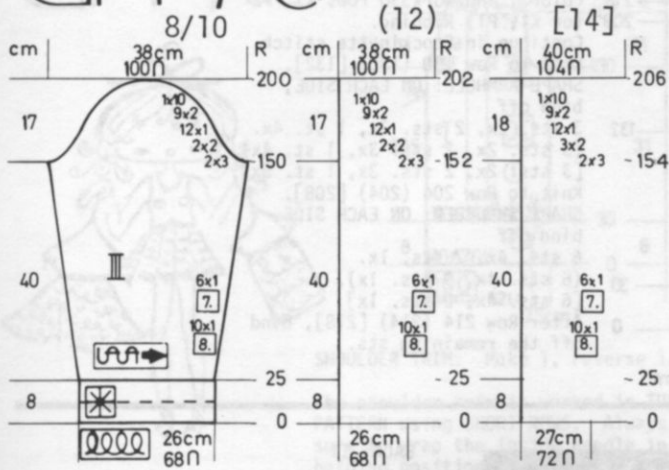

SLEEVES: III

Cast on 68 (68) [72] sts. with color 1 and work in PATTERN to Row 25.
Continue in Stockinette stitch.
ON EACH SIDE, for all sizes, increase 1 st. every 8th row 10x, every 7th row 6x.
After Row 150 (152) [154], SHAPE CAP: ON EACH SIDE, bind off 3 sts. 2x, 2 sts. 2x, 1 st. 12x, 2 sts. 9x.
(Same as first size).
[3 sts. 2x, 2 sts. 3x, 1 st. 12x, 2 sts. 9x].
After Row 200 (202) [206], bind off the remaining sts.

FRONT BANDS:

Make left front band first, mark with pins for buttons (6) then work the right front band and work the Buttonholes spaced according to the button spacing and over needles needed for button size.

Cast on 16 sts. with color 1 and work K1, P1 Ribbing long enough to go down fronts.

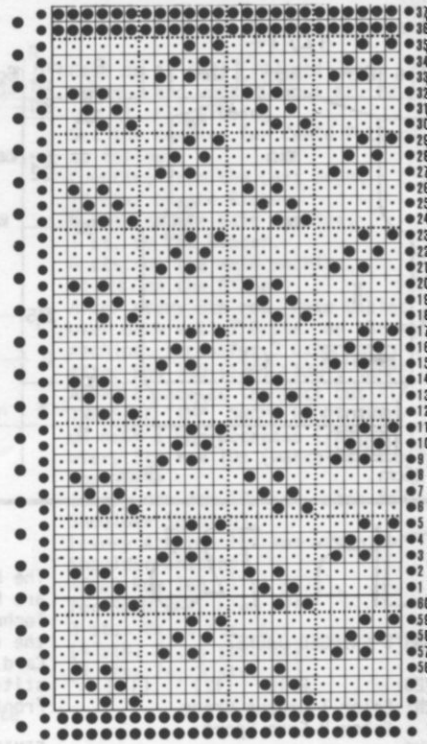

dk 724

WOMAN'S PULLOVER

SIZE: 12/14
YARN: Fortissima
GRAMS:
color 1 300
color 2 200
color 3 150
color 4 50
TENSION: 8 to 10
GAUGE: 12 sts. 16 rows = 5 cm (2")



Stockinette stitch with color stripes as shown on the Chart. Knitted sideways on the machine. Bands are ribbed.

FINISHING: See General Instructions. Sew bands in place.

LOWER BANDS: Color 1.

Pick up the front, then work 36 rows K3, P1 Ribbing. Bind off. Work the same for back band.

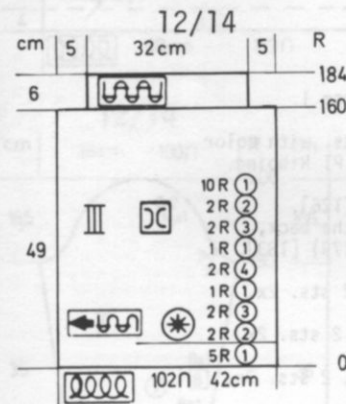

SLEEVES: III

Cast on 102 sts. with color 1 and work the REPEATED color stripes as shown on the Chart, beginning with 5 rows color 1 and REPEATING the stripes from *.
After Row 160, Set up for K3, P1 Ribbing. After Row 184, bind off.

NECKBAND:

Use the full width of both front and back bed of machine.

With color 1, cast on and work K3, P1 Ribbing. ON EACH SIDE, on every 2nd row, decrease 1 st. 9x.
After Row 18, bind off.

12/14

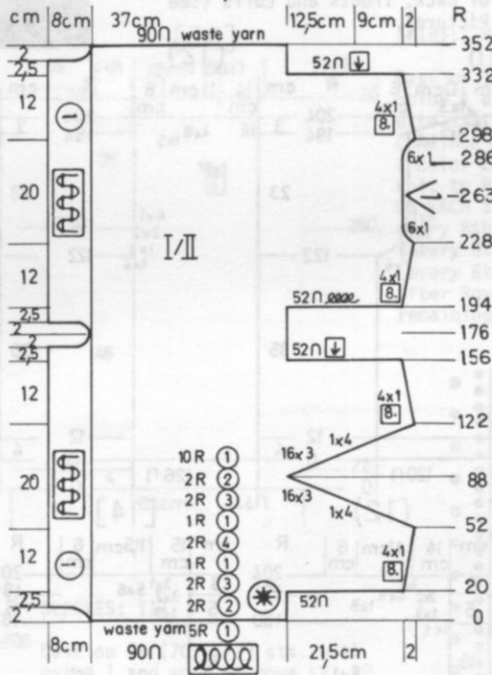

FRONT & BACK knitted in 1 piece.

With contrast waste yarn, cast on 90 sts. After knitting 8 to 10 rows, change to garment yarn - Knit 5 rows color 1 then follow the color stripes as shown on the Chart, repeating from *.
After Row 20, Cast on 52 sts. then on every 8th row SHAPE SHOULDER by increasing 1 st. 4x.
After Row 52, SHAPE NECK: Bind off 4 sts. 1x, 3 sts. 16x.
After Row 88, cast on 3 sts. 16x, 4 sts. 1x.
After Row 122, SHAPE SHOULDER Decrease 1 st. every 8th row 4x.
After Row 156, SHAPE ARMHOLE: Bind off 52 sts. Knit to Row 194, then cast on 52 sts. SHAPE SHOULDER: Increase 1 st. every 8th row 4x.
After Row 228, SHAPE NECK: Decrease 1 st. every 2nd row 6x.
Mark center neck edge with bit of contrast yarn at Row 263.
After Row 286, increase 1 st. every 2nd row 6x.
After Row 298, SHAPE SHOULDER: Decrease 1 st. every 8th row 4x.
After Row 332, SHAPE ARMHOLE: Bind off 52 sts.
After Row 352, remove the remaining 90 sts. onto contrast waste yarn.

MAN'S PULLOVER

SIZES: 34/36 (38) [40]
MATERIALS: Vienna
Color 1: 400 400 450
Color 2: 100 100 100
CONSTRUCTION: 7 to 9
GAUGE: 14 sts. 17 rows = 5 cm (2")

Stockinette stitch with a Norwegian Design. Punch your own Card. The bands are Ribbed.

FINISHING: See General Instructions.



BACK: II

Cast on 144 (152) [160] sts. with color 1 and work 30 rows K1, P1 Ribbing.
 Continue in the Norwegian Design for 90 rows. (Row 120).
 Continue in Stockinette stitch with color 1.
 Knit to Row 150 (160) [160].
SHAPE ARMHOLE: ON EACH SIDE, bind off
 3 sts. 2x, 2 sts. 3x, 1 st. 3x.
 (3 sts. 2x, 2 sts. 3x, 1 st. 5x).
 [3 sts. 2x, 2 sts. 3x, 1 st. 5x].
 Knit to Row 226 (240) [240].
SHAPE SHOULDER and WATCH FOR NECK SHAPING.

FOR SHOULDER, ON EACH SIDE, bind off 6 sts. 4x, 8 sts. 1x, (6 sts. 4x, 9 sts. 1x), [6 sts. 5x, 7 sts. 1x],
AT THE SAME TIME, after Row 228 (242) [242], **SHAPE NECK:** Put half the sts. on the left into holding position and complete the right side first.
***ON NECK SIDE,** bind off 13 (14) [14] sts. 1x, then 4 sts. 3x for all sizes. Bring the needles on the left into working position, knit 1 row to the left side, turn the Row Counter back to 228 and complete the left half. Follow the instructions from * and don't forget to complete the shoulder shaping.

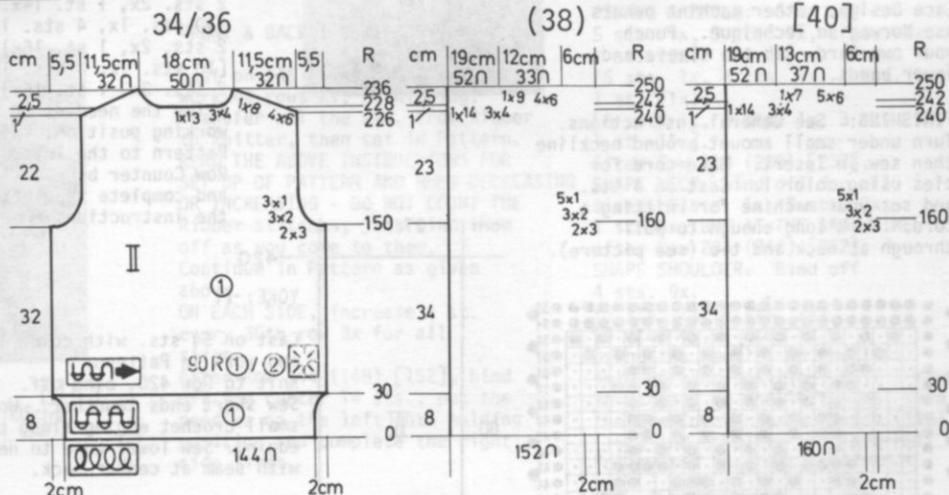
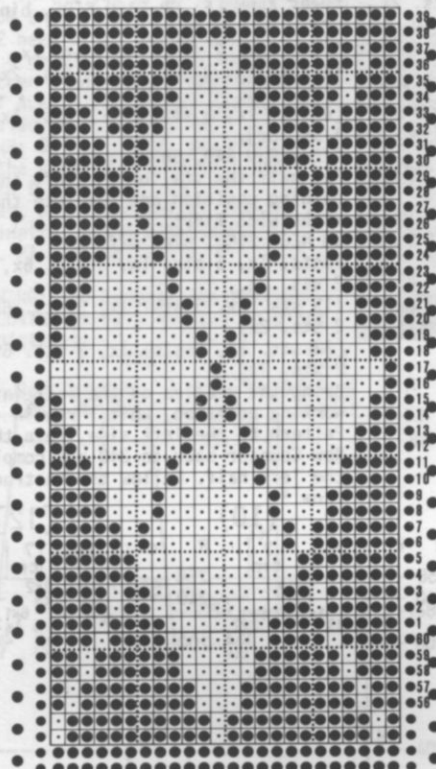

FRONT: I

Work the front the same as the back to Row 146 (156) [156].
 Put half the sts. on the left into holding position and complete the right side first.
*** ON FRONT EDGE,** decrease 1 st. every 2nd row 5x, every 4th row 20x (21x) [21x] BUT AT THE SAME TIME, after Row 150 (160) [160], **SHAPE ARMHOLE** same as the back and after Row 226 (240) [240], **SHAPE SHOULDER** same as the back. Bring the needles on the left into working position, knit 1 row to the left side, turn the Row Counter back to 146 (156) [156] and complete the left half. Follow the instructions from *.

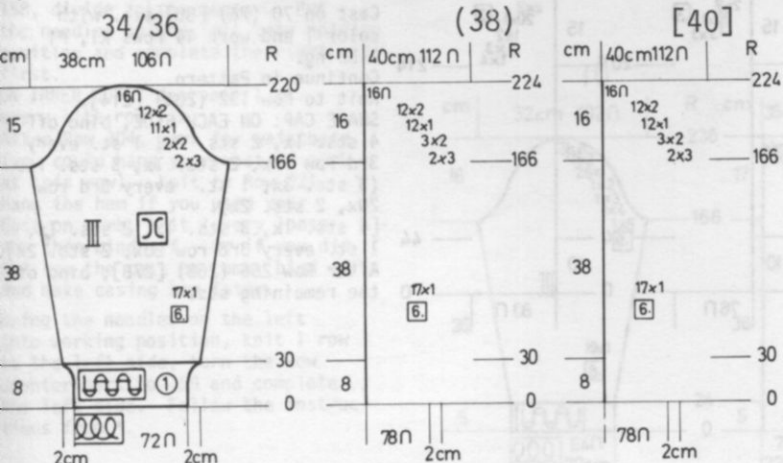
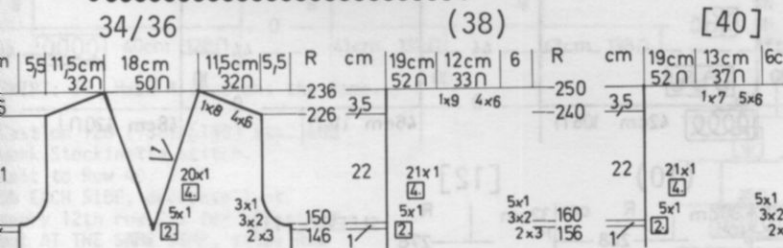

SLEEVES: III

Cast on 72 (78) [78] sts. with color 1 and work 30 rows K1, P1 Ribbing.
 Continue in Stockinette stitch.
ON EACH SIDE, for all sizes, increase 1 st. every 6th row 17x.
After Row 166, SHAPE CAP:
ON EACH SIDE, bind off
 3 sts. 2x, 2 sts. 2x, 1 st. 11x,
 2 sts. 12x.
 (3 sts. 2x, 2 sts. 3x, 1 st. 12x,
 2 sts. 12x).
 [3 sts. 2x, 2 sts. 3x, 1 st. 12x,
 2 sts. 12x].
After Row 220 (224) [224], bind off the remaining sts.



DK 726

WOMAN'S PULLOVER & SKIRT

SIZES: 6/8 (10) [12]
YARN: Venetia - Color 1
 Thread or Monofil -C-2.

GRAMS:
 color 1 Approximately 2 1/2 lbs. for all sizes.
 color 2 1 spool thread or Monofil

TENSION: 4 to 6
GAUGE: 12 1/2 sts. 22 1/2 rows = 5 cm

Studio Machine owners work Punch Lace Design. Other machine owners use Norwegian Technique. Punch your own Card. Rib the sleeve and lower bands.

FINISHING: See General Instructions. Turn under small amount around neckline then sew in Insert. Make cord for ties using color 1. Cast on 4 sts. and set your machine for knitting a cord. Work long enough to pull through at neck and tie (see picture).

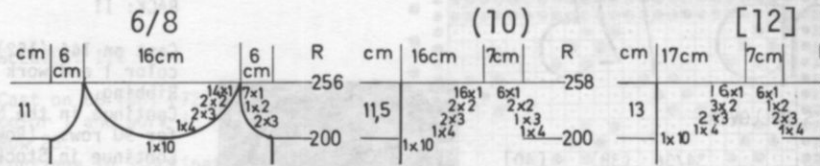

FRONT: I

Work the front the same as the back to Row 200 (200) [202]. Put half the sts. on the left into holding position and complete the right side first.
 *SHAPE ARMHOLE same as the back and ON NECK SIDE, bind off 10 sts. 1x, 4 sts. 1x, 3 sts. 2x, 2 sts. 2x, 1 st. 14x. (10 sts. 1x, 4 sts. 1x, 3 sts. 2x, 2 sts. 2x, 1 st. 16x). [10 sts. 1x, 4 sts. 1x, 3 sts. 2x, 2 sts. 3x, 1 st. 16x]. Bring the needles on the left into working position, knit 1 row in Pattern to the left side, turn the Row Counter back to 200 (200) [202] and complete the left half. Follow the instructions from *.

BACK: II

Cast on 106 (114) [120] sts. with color 1 and work 44 rows K1, P1 Ribbing. Continue in Pattern. Knit to Row 200 (200) [202]. SHAPE ARMHOLE: ON EACH SIDE, bind off 3 sts. 2x, 2 sts. 1x, 1 st. 7x. (4 sts. 1x, 3 sts. 1x, 2 sts. 2x, 1 st. 6x). [4 sts. 1x, 3 sts. 2x, 2 sts. 1x, 1 st. 6x]. After Row 240, SHAPE NECK: Put half the sts. on the left into holding position and complete the right side first.

*ON NECK SIDE, bind off 13sts. 1x, 5 sts. 1x, 3 sts. 6x, 2 sts. 1x. (13 sts. 1x, 5 sts. 1x, 3 sts. 6x, 2 sts. 2x). [13 sts. 1x, 5 sts. 1x, 3 sts. 6x, 2 sts. 3x]. Bring the needles on the left into working position, knit 1 row in Pattern to the left side, turn the Row Counter back to 240 and complete the left half. Follow the instructions from *.

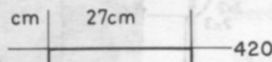

YOKE: IV

Cast on 54 sts. with color 1 and work in Pattern. Knit to Row 420, bind off. Sew short ends together. Work small crochet edging along top edging. Sew lower edge to neckline with seam at center back.

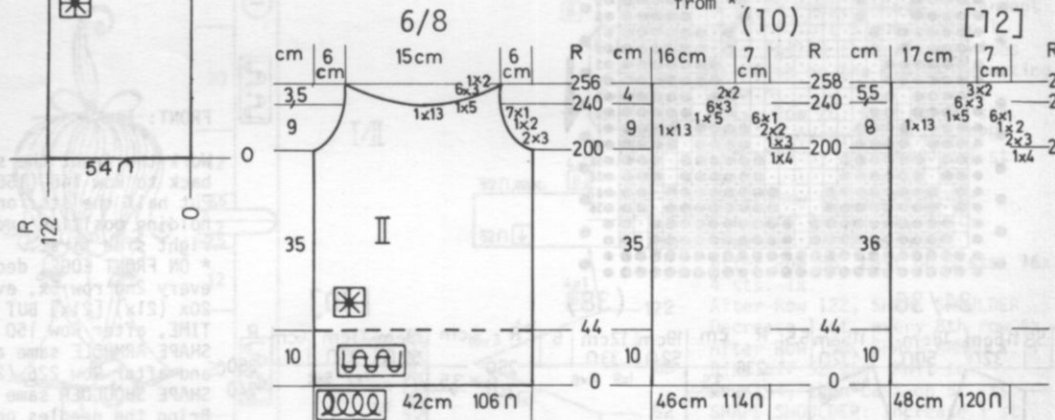

FRONT: II

SLEEVES: III

Cast on 70 (76) [80] sts. with color 1 and work 44 rows K1, P1 Ribbing. Continue in Pattern. Knit to Row 192 (204) [214]. SHAPE CAP: ON EACH SIDE, bind off 4 sts. 1x, 2 sts. 2x, 1 st. every 3rd row 17x, 2 sts. 1x, 3 sts. 1x. (3' sts. 3x, 1 st. every 3rd row 20x, 2 sts. 2x). [4 sts. 1x, 3 sts. 1x, 2 sts. 1x, 1 st. every 3rd row 20x, 2 sts. 2x]. After Row 256 (268) [278], bind off the remaining sts.

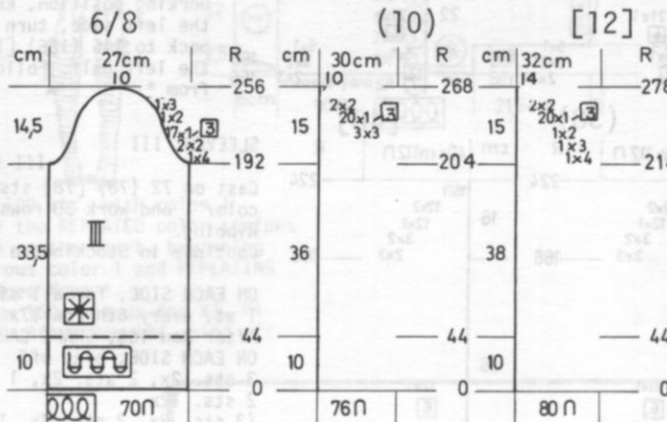

SKIRT:

Cast on 200 sts. with color 1 and work in Pattern to Row 856. Bind off. Sew back seam, make hem at waist edge then pull elastic through casing. Make hem at lower edge or you can work small crochet edging.

WOMAN'S TWO PIECE DRESS

SIZES: 10 (12) [14]
 YARN: Fortissima
 GRAMS: 800 850 900
 TENSION: 4 to 5
 GAUGE: 16 1/2 sts. 22 1/2 rows = 5 cm

The front and back of Pullover is in a Ribbing Pattern.
 After Working the Rib Band, transfer all the sts. to main machine then set into Pattern as follows. Leave 6 needles in the center of Ribber in the out of work position then ON EACH SIDE, bring up into work 2 needles on the Ribber, leave 6 needles of ribber out of work then bring up 2 ribber needles. REPEAT ACROSS the Ribber bed on each side. PH LEVER ON "H".
 PATTERN: ON EVERY ROW, you must RACK the needles from 5 to 1 and back to 5 etc. etc.
 Sleeves, Skirt and Collar are Stockinette stitch with Bands in K1, P1 Ribbing.

FINISHING: See General Instructions. Fold Collar in half and sew in place (see picture).

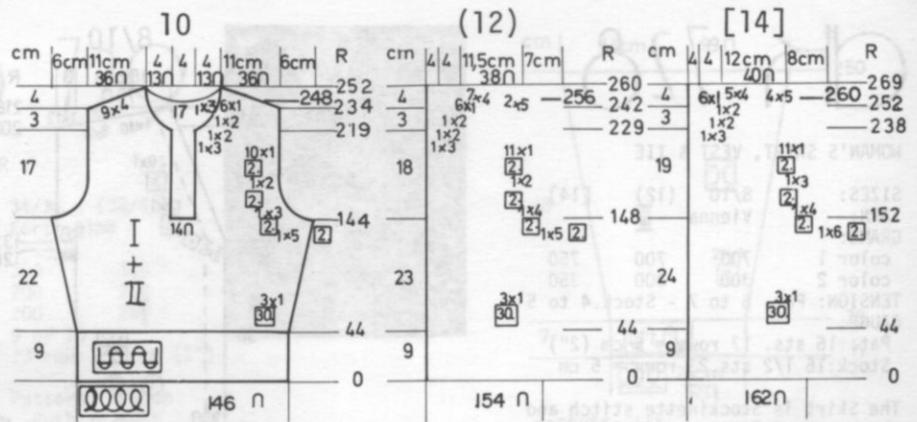

FRONT & BACK I & II

Cast on 146 (154) [162] sts. and work 44 rows K1, P1 Ribbing. Transfer all the sts. from Ribber to Knitter, then set in Pattern. READ THE ABOVE INSTRUCTIONS FOR SET UP OF PATTERN and WHEN DECREASING OR INCREASING - DO NOT COUNT THE Ribber stitches, just bind them off as you come to them. Continue in Pattern as given above.
 ON EACH SIDE, increase 1 st. every 30th row 3x for all sizes.
 After Row 144 (148) [152], bind off the center 14 sts., put the needles on the left into holding position and complete the right side first.

*SHAPE ARMHOLE: Bind off 5 sts. 1x, 3 sts. 1x, 2 sts. 1x, 1 st. 10x.
 (5 sts. 1x, 4 sts. 1x, 2 sts. 1x, 1 st. 11x).
 [6 sts. 1x, 4 sts. 1x, 3 sts. 1x, 1 st. 11x].
 After Row 219 (229) [237], SHAPE NECK, bind off for all sizes, 3 sts. 1x, 2 sts. 2x, 1 st. 6x, BUT AT THE SAME TIME, after Row 234 (242) [252], SHAPE SHOULDER: Bind off 4 sts. 9x.
 (5 sts. 2x, 4 sts. 7x).
 [5 sts. 4x, 4 sts. 5x].
 Bring the needles on the left into working position, knit 1 row in Pattern to the left side, turn the Row Counter back to 144 (148) [152] and complete the left half. Follow the Instructions from *

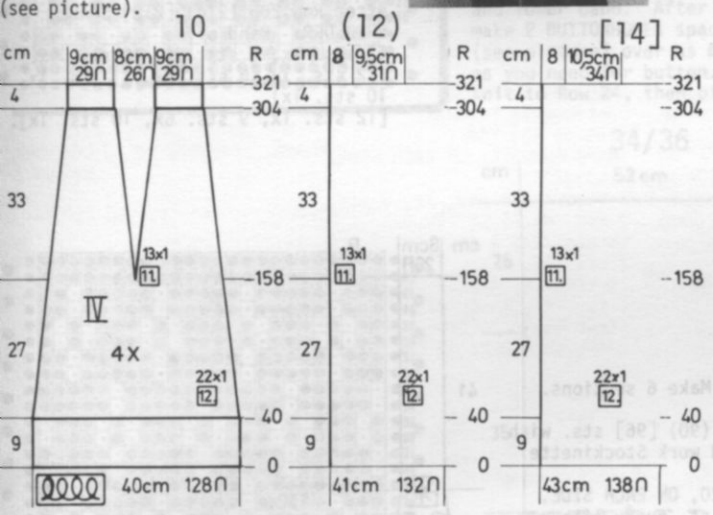

SKIRT: IV Make 4 sections the same.

Cast on 128 (132) [138] sts. and work Stockinette stitch. Knit to Row 40.
 ON EACH SIDE, decrease 1 st. every 12th row 22x for all sizes, but AT THE SAME TIME, after Row 158, divide in the center. Put the needles on the left into holding position and complete the right side first.
 ON INNER EDGE, decrease 1 st. every 11th row 13x.
 After Row 304, mark for waistband (you could hang your cast on comb at this row). Knit to Row 321. Hang the hem if you used your Cast on comb, knit 1 very loose row then bind off. Or if you did not use the cast on comb, bind off and make casing hem later.
 Bring the needles on the left into working position, knit 1 row to the left side, turn the Row Counter back to 158 and complete the left side. Follow the instructions from *.

COLLAR:

Cast on 60 sts. and work Stockinette stitch.
 ON EACH SIDE, cast on 5 sts. 7x.
 After Row 37, ON EACH SIDE, cast on 35 sts.
 Knit to Row 74.
 ON EACH SIDE, bind off 35 sts.
 ON EACH SIDE, bind off 5 sts. 7x.
 After Row 111, bind off.

BACK NECK SHAPING: Work the back the same as the front (BUT DO NOT BIND OFF THE CENTER 14 sts.) and SHAPE ARMHOLE ON EACH SIDE same as the front. Knit to Row 234 (242) [252] then SHAPE SHOULDER SAME AS THE FRONT but AT THE SAME TIME, after Row 248 (256) [260], put half the sts. on the left into holding position and complete the right side first.
 *ON NECK SIDE, bind off for all sizes, 17 sts. 1x, 3 sts. 1x. Bring the needles on the left into working position, knit 1 row to the left side, turn the Row Counter back to 248 (256) [260] and complete the left half. Follow the instructions from * and don't forget to complete the shoulder shaping.

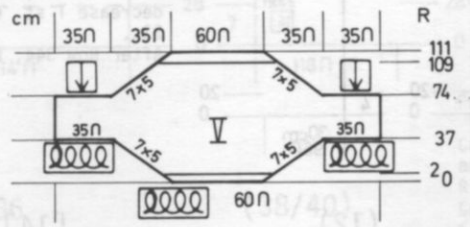

SLEEVES: III

Cast on 64 (70) [76] sts. and work 24 rows K1, P1 Ribbing. Continue in Stockinette stitch. ON EACH SIDE, increase 1 st. every 8th row 19x. (every 8th row 21x). [every 8th row 10x, every 7th row 13x].
 After Row 166 (178) [192], SHAPE CAP: ON EACH SIDE, bind off 5 sts. 1x, 4 sts. 1x, 3 sts. 1x, 2 sts. 1x, 1 st. 26x, 2 sts. 1x, 3 sts. 3x.
 (5 sts. 1x, 4 sts. 1x, 3 sts. 1x, 2 sts. 2x, 1 st. 26x, 3 sts. 2x, 4 sts. 2x).
 [5 sts. 1x, 4 sts. 1x, 3 sts. 1x, 2 sts. 1x, 1 st. 28x, 2 sts. 2x, 3 sts. 5x].

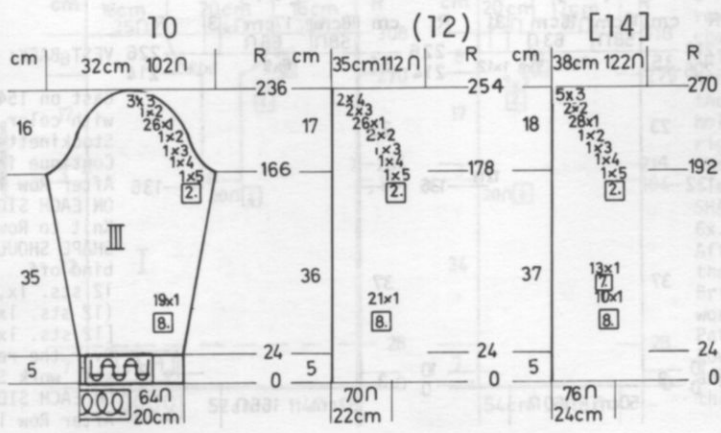

DK 728

WOMAN'S SKIRT, VEST & TIE

SIZES: 8/10 (12) [14]
YARN: Vienna
GRAMS:
 color 1 700 700 750
 color 2 300 300 350
TENSION: Pat. 6 to 7 - Stock.4 to 5
GAUGE:
 Pat: 16 sts. 17 rows = 5 cm (2")
 Stock: 16 1/2 sts. 23 rows = 5 cm

The Skirt is Stockinette stitch and the Vest and Tie in a Norwegian Design. Punch your own Card.

FINISHING: See General Instructions.
Skirt: Make hem at lower edge and at waist. Pull elastic through casing at waist.
Jacket: Belt - Cast on 10 sts. with color 1 and knit circular approximately 150 cm long (59"). At waist height on Jacket, with purl side facing you, pick up 190 sts. and work 10 rows Stockinette stitch. Remove onto waste yarn. Sew down through the open sts. for casing then pull belt through.
Tie: Line with press on Interfacing then close seams.

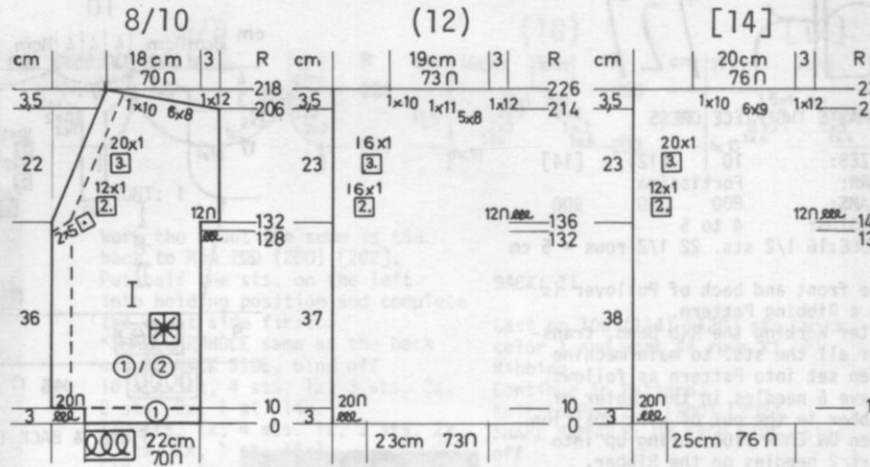

VEST FRONT: I Make 1, reverse 1.

Cast on 70 (73) [76] sts. with color 1 and work 10 rows Stockinette stitch.
 ON THE LEFT (right for 2nd section, cast on 20 sts. Continue in Pattern.
 Knit to Row 128 (132) [136].
 ON OPPOSITE SIDE OF SLIDE, put into holding position 5 sts. 2x, then bring them all back into working position.

To make the neck decreases, ALWAYS hang the 10th st. onto the 11th st. and move the sts. in to fill the empty needle.

After Row 132 (140) [140], cast on 12 sts. and ON NECK SIDE, decrease 1 st. every 2nd row 12x, every 3rd row 20x (every 2nd row 16x, every 3rd row 16x).
 [every 2nd row 12x, every 3rd row 20x].
 After Row 206 (214) [218] SHAPE SHOULDER: Bind off 12 sts. 1x, 8 sts. 6x, 10 sts. 1x. (12 sts. 1x, 8 sts. 5x, 11 sts. 1x, 10 sts. 1x).
 [12 sts. 1x, 9 sts. 6x, 10 sts. 1x].

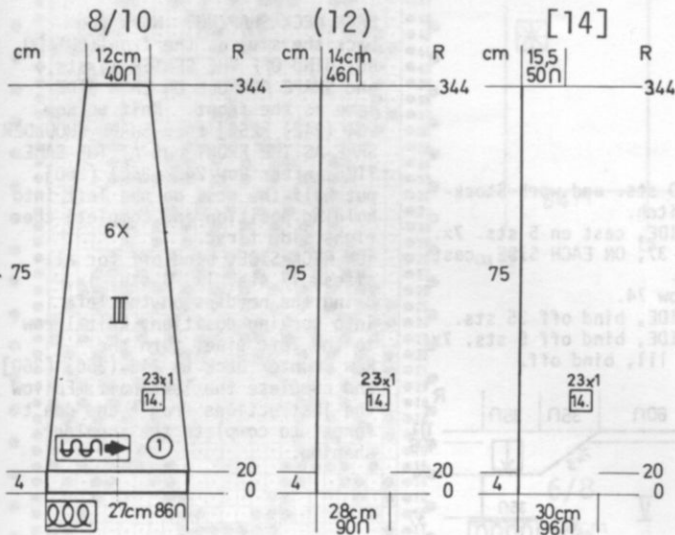

SKIRT: III Make 6 sections.

Cast on 86 (90) [96] sts. with color 1 and work Stockinette stitch.
 After Row 20, ON EACH SIDE, decrease 1 st. every 14th row 23x.
 After Row 344, bind off.

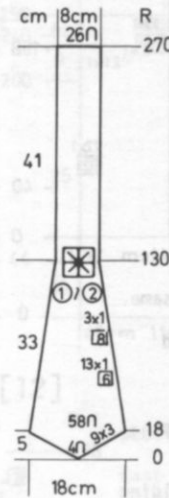

TIE:

Cast on 4 sts. Work in Pattern. ON EACH SIDE, cast on 3 sts. every 2nd row 9x.
 After Row 18, ON EACH SIDE, decrease 1 st. every 6th row 13x, every 8th row 3x.
 Knit to Row 270. Bind off.

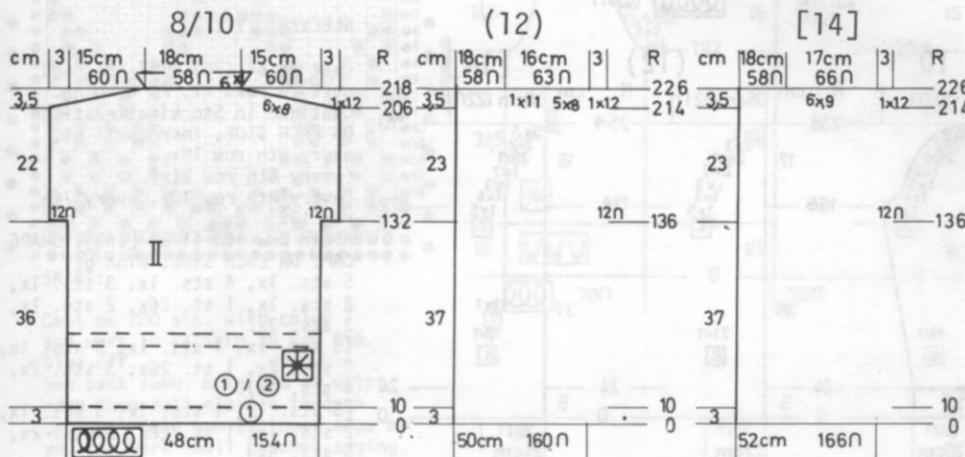

VEST BACK:

Cast on 154 (160) [166] sts. with color 1 and work 10 rows Stockinette stitch. Continue in Pattern.
 After Row 132 (136) [136], ON EACH SIDE, cast on 12 sts. Knit to Row 206 (214) [214].
 SHAPE SHOULDER: ON EACH SIDE, bind off 12 sts. 1x, 8 sts. 6x. (12 sts. 1x, 8 sts. 5x, 11 sts. 1x).
 [12 sts. 1x, 9 sts. 6x].
 Over the remaining 58 (63) [66] sts. work Stockinette stitch and ON EACH SIDE, increase 1 st. 6x.
 After Row 12, remove on waste yarn.

hp 729

MAN'S PULLOVER

SIZES: 34/36 (38/40)
 YARN: Fortissima
 GRAMS:
 color 1 300 350
 color 2 200 250
 color 3 200 250
 TENSION: 9 or 10
 GAUGE: 11 sts. 23 rows = 5 cm (2")

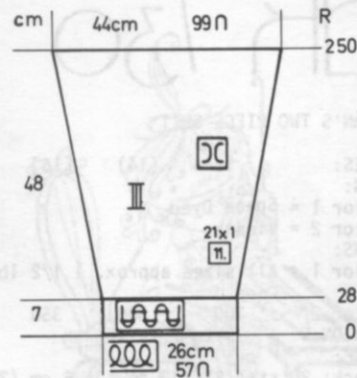

SLEEVES: III

Cast on 57 sts. with color 1 and work 28 rows K2, P2 (or K1 P1) Ribbing. Continue in Pattern same as the front and back. ON EACH SIDE, increase 1 st. every 11th row 21x. After Row 250, bind off.

A Tuck stitch Pattern. Punch your own card. Push in BOTH TUCK BUTTONS and work 6 rows color 2, 6 rows color 3, 6 rows color 1. You can use your Color Changer. Bands are Ribbed.

FINISHING: See General Instructions.

FRONT BANDS: Make 2.-Omit Buttonholes on right side of front. Pick up the sts. along left edge of Pullover and with color 1, work same ribbing as you did for sleeves and lower band. After Row 12, make 2 BUTTONHOLES spaced evenly (see picture) over as many stitches as you need for button. Knit to Row 24, then bind off.

COLLAR:

Sew shoulder seams first, then pick up the sts. across neckline and half of the bands. Work same Ribbing as for other sections. After Row 48, bind off.

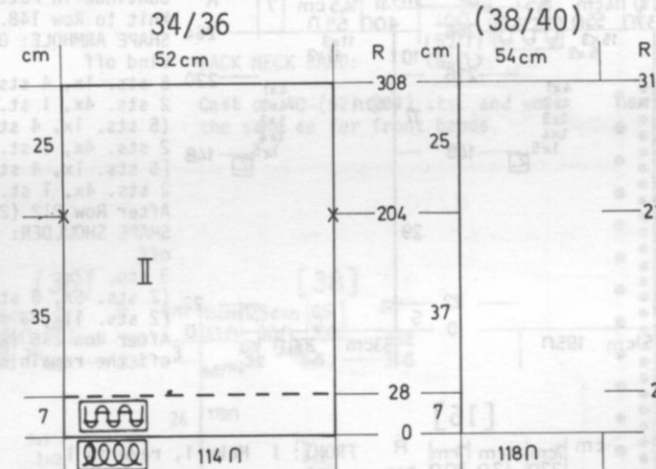

BACK: II

Cast on 114 (118) sts. with color 1 and work 28 Rows K2, P2 (or K1, P1) Ribbing. Continue in Pattern same as the Front. Mark each side after Row 204 (214) with a bit of yarn (for setting in sleeves). Knit to Row 308 (318) then bind off.

FRONT: I

Cast on 114 (118) sts. with color 1 and work 28 rows K2, P2 (or K1, P1) Ribbing. Continue in Tuck Pattern, beginning 6 rows color 2, 6 rows color 3, 6 rows color 1 and REPEAT the color changes. Knit to Row 174 (184). Bind off the center 20 sts. and put the needles on the left into holding position and complete the right side first. *Mark Row 204 (214) for setting in Sleeve, then knit to Row 269 (279). SHAPE NECK: Bind off 2 sts. 3x, 1 st. 6x. After Row 308 (318), bind off the remaining sts. Bring the needles on the left into working position, knit 1 row in Pattern to the left side, turn the Row Counter back to 174 (184) and complete the left side. Follow the instructions from *.

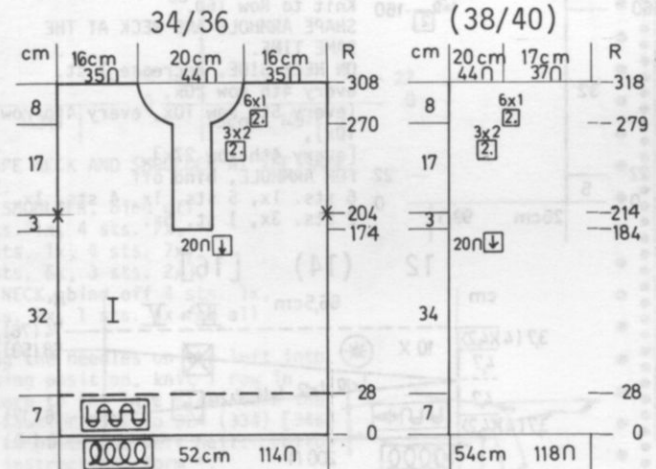

dk 730

WOMAN'S TWO PIECE SUIT

SIZES: 12 (14) [16]

YARN:

color 1 = Space Dyed
color 2 = Vienna

GRAMS:

color 1 - All sizes approx. 1 1/2 lb
Cone.

color 2 300 300 350

TENSION: 5 to 7

GAUGE:

Stock: 20 sts. 22 1/2 rows = 5 cm (2")

Pat: 19 sts. 21 1/2 rows = 5 cm (2")

Fronts and back of Jacket are a Shadow Lace Pattern. Stockinette stitch for sleeves, skirt (with Short Rows), and part of the front and neckbands. Lower edge of Jacket and Sleeve bands are Ribbed.

FINISHING: See General Instructions. Skirt: Weave the open sts. of skirt together. Hem lower edge and make hem at waistline then pull elastic through casing.

PATTERN for Fronts and Back.

After the Ribbing is completed, set up for Pattern using EVERY NEEDLE ON BOTH BEDS. -Transfer all main bed stitches to the Ribber (to the empty needles) Leave empty needles on main bed in knitting position. Push in BOTH PART BUTTONS on main bed Carriage (Studio on Slip). Punch Card in machine ready to go. *Knit 10 rows.

Transfer the 5 sts. for Pattern from the main machine to the Ribber (If you have a Shadow Lace Tool, you can use it). Ignore all single stitches. REPEAT FROM *.

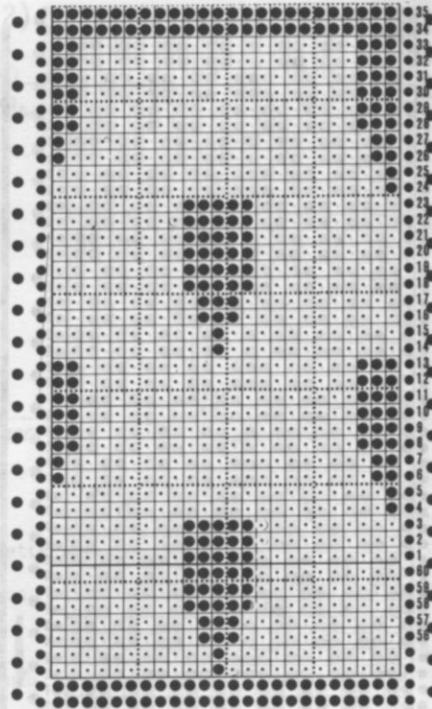

RIGHT FRONT & NECKBAND

Cast on 180 (187) [196] sts. with color 2 and work K1, P1 Ribbing. After Row 9, MAKE BUTTONHOLES as shown on the Chart COUNTING FROM THE RIGHT EDGE. After Row 18, work Stockinette stitch with color 1 to row 22.

Make LEFT band the same way but omit the buttonholes.

JACKET BACK: II

Cast on 186 (195) [200] sts. with color 2 and work 22 rows K1, P1 Ribbing.

Continue in Pattern.

Knit to Row 148.

SHAPE ARMHOLE: ON EACH SIDE, bind off

5 sts. 1x, 4 sts. 1x, 3 sts. 1x,

2 sts. 4x, 1 st. 5x.

(5 sts. 1x, 4 sts. 1x, 3 sts. 1x,

2 sts. 4x, 1 st. 4x).

[5 sts. 1x, 4 sts. 1x, 3 sts. 1x,

2 sts. 4x, 1 st. 4x].

After Row 212 (216) [220],

SHAPE SHOULDER: ON EACH SIDE, bind off

3 sts. 17x.

(2 sts. 5x, 3 sts. 15x).

[2 sts. 11x, 3 sts. 11x].

After Row 246 (256) [264], bind off the remaining sts.

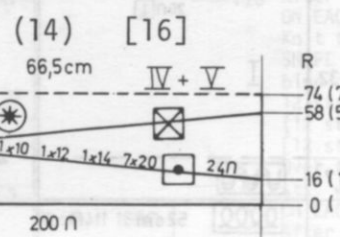
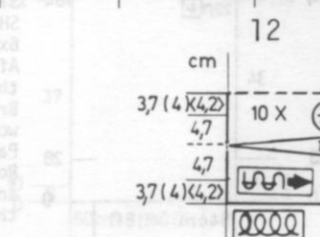
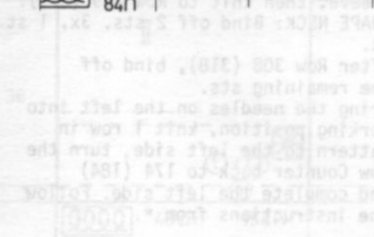
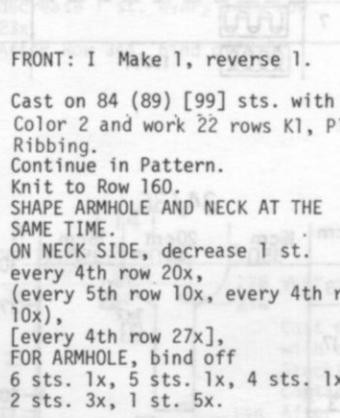
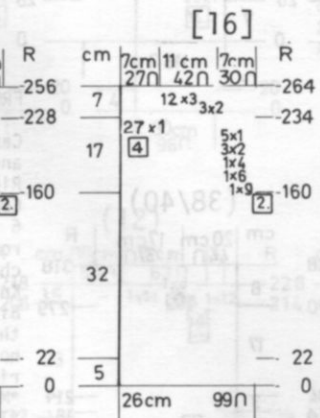
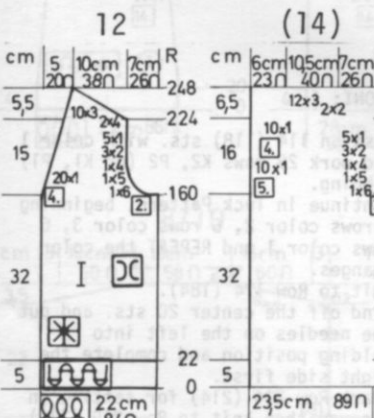
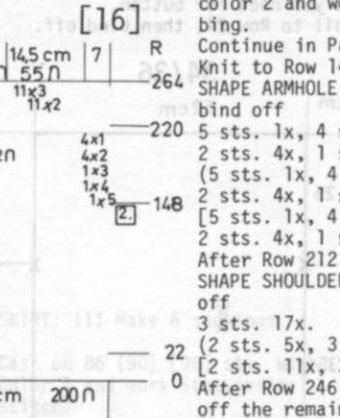
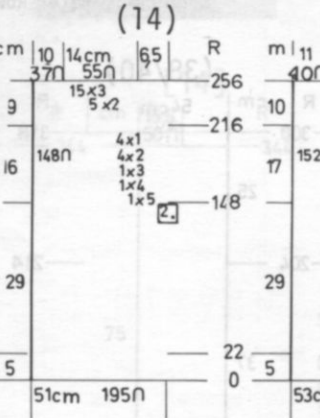
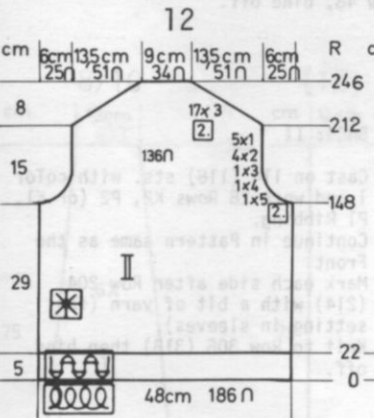
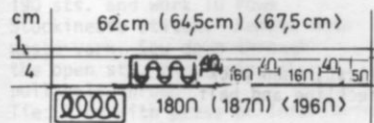

(6 sts. 1x, 5 sts. 1x, 4 sts. 1x,

2 sts. 3x, 1 st. 5x).

[9 sts. 1x, 6 sts. 1x, 4 sts. 1x,

2 sts. 3x, 1 st. 5x].

After Row 224 (228) [234], SHAPE

SHOULDER, bind off

4 sts. 2x, 3 sts. 10x.

(2 sts. 2x, 3 sts. 12x).

[2 sts. 3x, 3 sts. 12x].

SKIRT:

With contrast waste yarn, cast on 200 stitches. Work Stockinette stitch. After 8 to 10 rows, change to color 1, put Counter at 0.

*Knit to Row 16 (17) [18].

Work Short Rows.

ON OPPOSITE SIDE OF SLIDE, put into holding position, 10 sts. 1x, 12 sts. 1x, 14 sts. 1x, 20 sts. 7x.

ON OPPOSITE SIDE OF SLIDE, bring back

into working position, 20 sts. 7x,

14 sts. 1x, 12 sts. 1x, 10 sts. 1x.

REPEAT from * 10x more.

Remove onto contrast waste yarn.

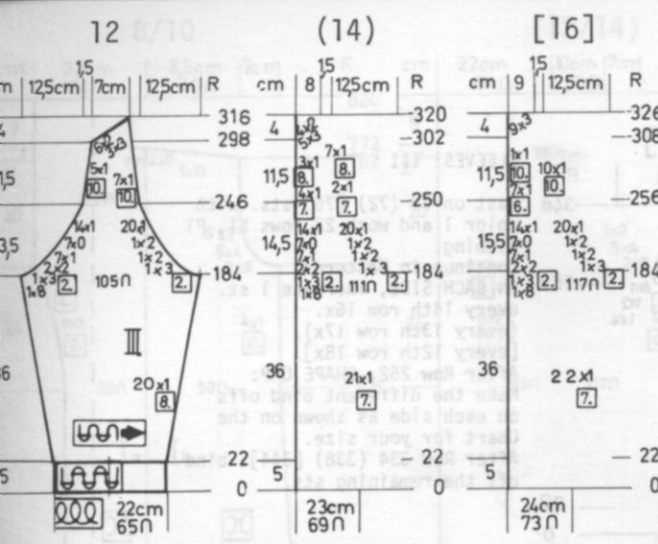

SLEEVES: III Make 1, reverse 1.

Cast on 65 (69) [73] sts. with color 1 and work 22 rows K1, P1 Ribbing. Continue in Stockinette stitch. ON EACH SIDE, increase 1 st. every 8th row 20x. (every 7th row 21x). [every 7th row 22x]. After Row 184, SHAPE CAP AND SADDLE SHOULDER. Please follow the different bind-offs for EACH SIDE as shown on the Chart in YOUR SIZE. After Row 298 (302) [308], Work SHORT ROWS: ON OPPOSITE SIDE OF SLIDE, put into holding position, 3 sts. 3x, 2 sts. 6x. (3 sts. 5x, 2 sts. 4x). [3 sts. 9x]. Bring all the needles back into working position and bind off loosely.



732

MAN'S CARDIGAN

SIZES: 34 (36) [38]
 YARN: Fortissima
 COLORS: color 1 400 450 500
 color 2 350 400 450
 TENSION: 6 or 7
 GAUGE: 14 sts. 27 rows = 5 cm (2")

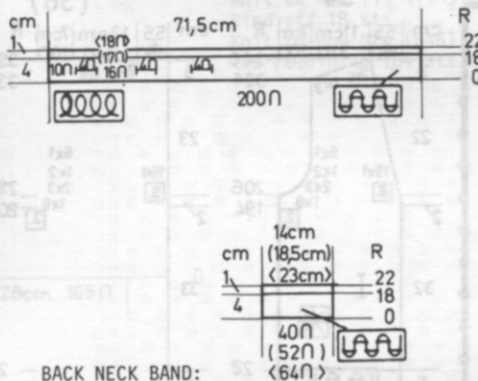

FRONT BAND: Cast on 200 sts. with color 1 and work 18 rows K1, P1 Ribbing, making BUTTONHOLES after Row 9 over 4 needles as spaced on the Chart for your size. After Row 18, work 4 rows Stockinette Stitch SEPARATELY on each bed then remove the sts. separately from each bed onto contrast waste yarn. Make a 2nd band the same but omit the Buttonholes.

Fair Isle Pattern using the Ribber and Color Changer. Bands are Ribbed.

FINISHING: See General Instructions.

BACK NECK BAND: Cast on 40 (52) [64] sts. and work the same as for front bands.

The Cast on stitches are shown for the main machine only but you will use the same number of sts. for the ribber and the shapings are given for the main machine but you must also shape on the Ribber as well.

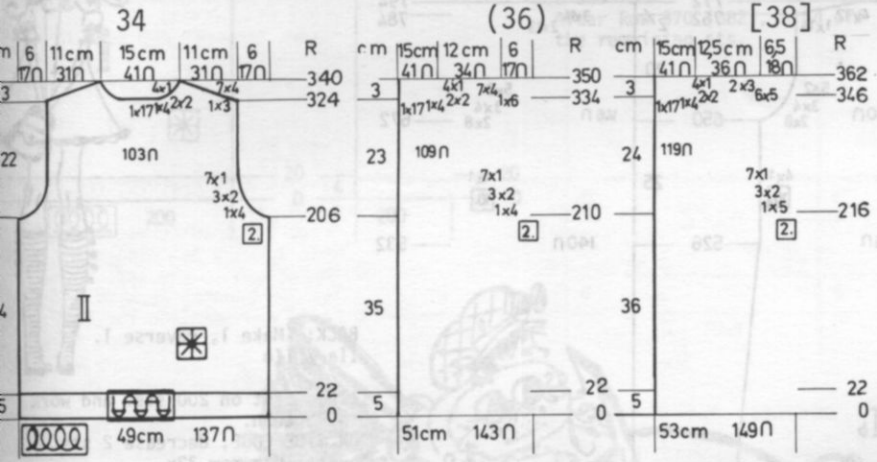

BACK: II
 Cast on 137 (143) [149] sts. with color 1 and work 22 rows K1, P1 Ribbing. Continue in Pattern. Knit to Row 206 (210) [216]. SHAPE ARMHOLE: ON EACH SIDE, bind off 4 sts. 1x, 2 sts. 3x, 1 st. 7x. (4 sts. 1x, 2 sts. 3x, 1 st. 7x). [5 sts. 1x, 2 sts. 3x, 1 st. 7x]. Knit to Row 324 (334) [346]. Bind off the center 17 sts., put the needles on the left into holding position and complete the right side first.

*SHAPE NECK AND SHOULDER AT THE SAME TIME.
 FOR SHOULDER, bind off 3 sts. 1x, 4 sts. 7x, (6 sts. 1x, 4 sts. 7x), [5 sts. 6x, 3 sts. 2x]. FOR NECK, bind off 4 sts. 1x, 2 sts. 2x, 1 sts. 4x for all sizes. Bring the needles on the left into working position, knit 1 row in Pattern to the left side, turn the Row Counter back to 324 (334) [346] and complete the left half. Follow the instructions form *.

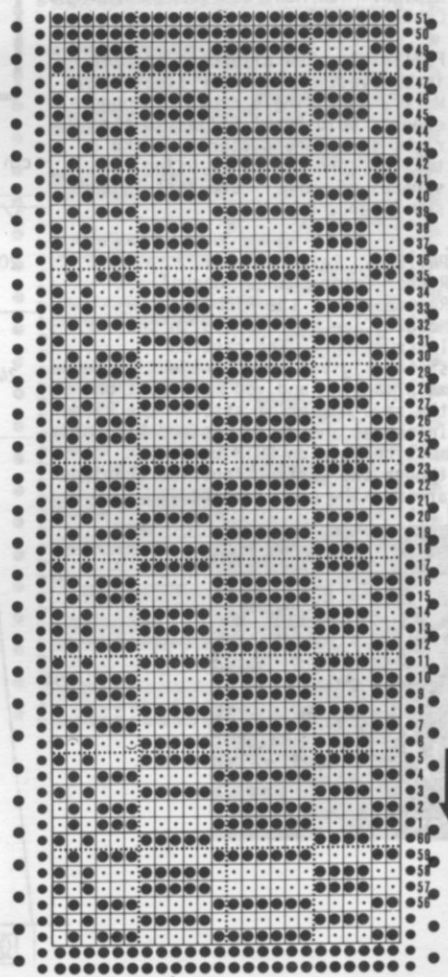

np 732

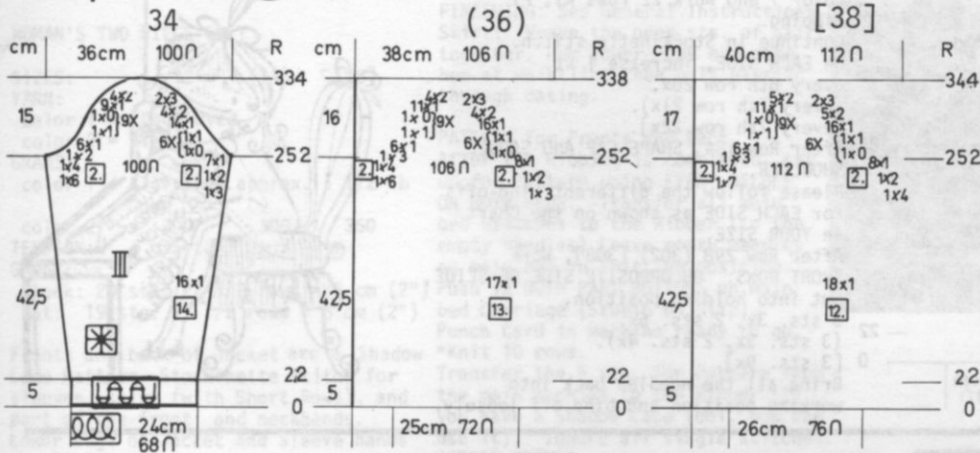

SLEEVES: III

Cast on 68 (72) [76] sts. with color 1 and work 22 rows K1, P1 Ribbing.
Continue in Pattern.
ON EACH SIDE, increase 1 st. every 14th row 16x.
(every 13th row 17x).
[every 12th row 18x].
After Row 252, SHAPE CAP: Make the different bind offs on each side as shown on the Chart for your size.
After Row 334 (338) [344], bind off the remaining sts.

FRONT: Make 1, reverse 1.

dk 731

WOMAN'S BEACH ROBE

SIZES: 8/10 (12/14)
YARN: Micaela
GRAMS: color 1 650 700
color 2 650 700
TENSION: 4 to 6
GAUGE: 28 sts. 28 rows = 5 cm (2")

Punch your own Card for the Norwegian Design. YOU MUST USE YOUR RIBBER and COLOR CHANGER.

FINISHING: Sew all seams and set in sleeves. Turn under sleeve hem. Work 2 rows single crochet around all edges. Fold Shawl Collar to the right side (see picture). Make a twisted cord for belt, using 20 strands of yarn. Make tassels and sew to ends of belt.

PATTERN: Refer to your Ribber Color Changer Manual. Remember that the Ribber Needles are NOT counted in the Instructions. The cast on stitches given are for the main machine and you must cast on the same number of sts. on the Ribber. Increases and decreases and bind-offs must be made on BOTH beds even though the instructions for shapings are for the main machine.

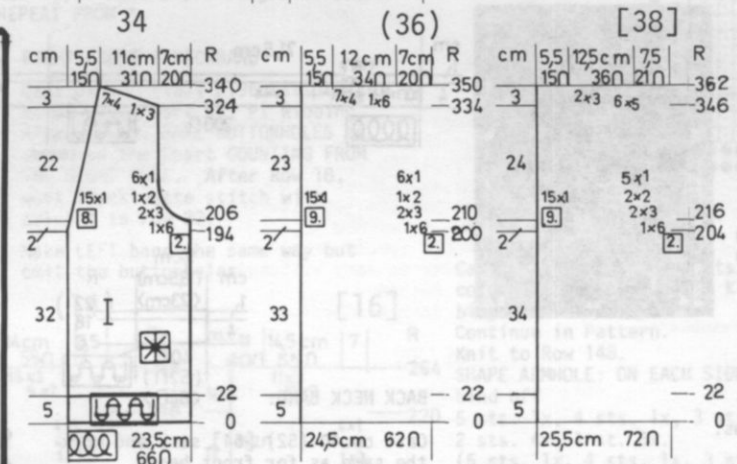

Cast on 66 (69) [72] sts. with color 1 and work 22 rows K1, P1 Ribbing.
Continue in Pattern
Knit to Row 194 (200 [204]).
SHAPE NECK: ON NECK SIDE, decrease 1 st. every 8th row 15x
(every 9th row 15x)
[every 9th row 15x]
AND AT THE SAME TIME, after Row 206 (210) [216], SHAPE ARMHOLE.
Bind off
6 sts. 1x, 3 sts. 2x, 2 sts. 1x
1 st. 6x.
(6 sts. 1x, 3 sts. 2x, 2 sts. 1x
1 st. 6x).
[6 sts. 1x, 3 sts. 2x, 2 sts. 2
1 st. 5x].
After Row 324 (334) [346], SHAPE SHOULDER same as the back.

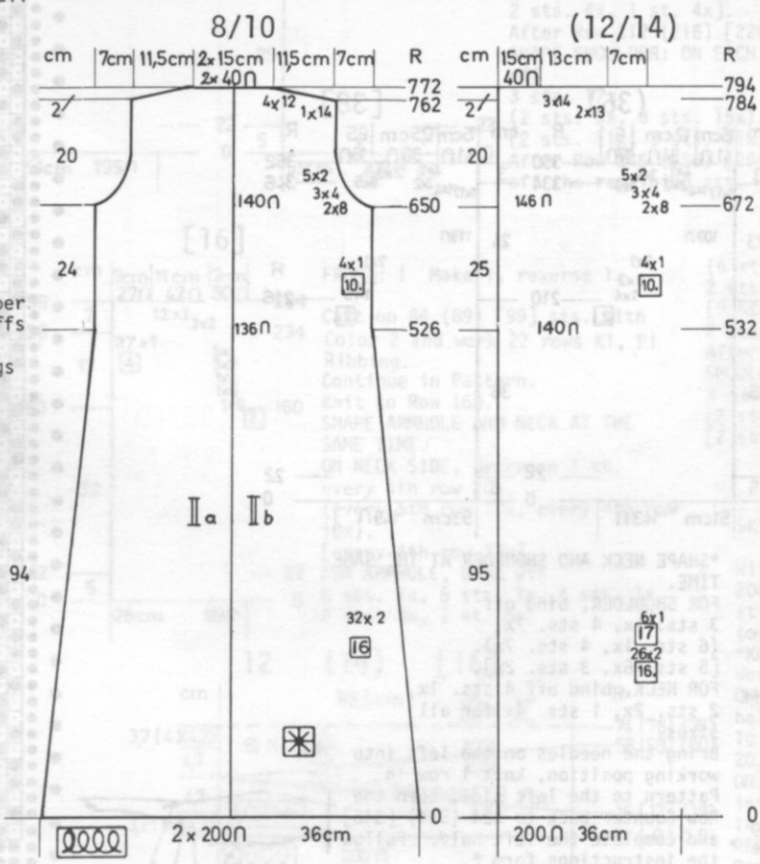

BACK: Make 1, reverse 1. I1a / I1b

I1b, Cast on 200 sts. and work in Pattern.
ON SIDE EDGE, decrease 2 sts. every 16th row 32x
(2 sts. every 16th row 26x, 1 st. every 17th row 6x).
After Row 526 (532), ON SIDE EDGE, increase 1 st. every 10th row 4x.
After Row 650 (672) SHAPE ARMHOLE: Bind off
8 sts. 2x, 4 sts. 3x, 2 sts. 5x.
Knit to Row 762 (784).
SHAPE SHOULDER: Bind off
14 sts. 1x, 12 sts. 4x.
(13 sts. 2x, 14 sts. 3x).
After Row 772 (794), bind off the remaining 40 sts.



8/10

(12/14)

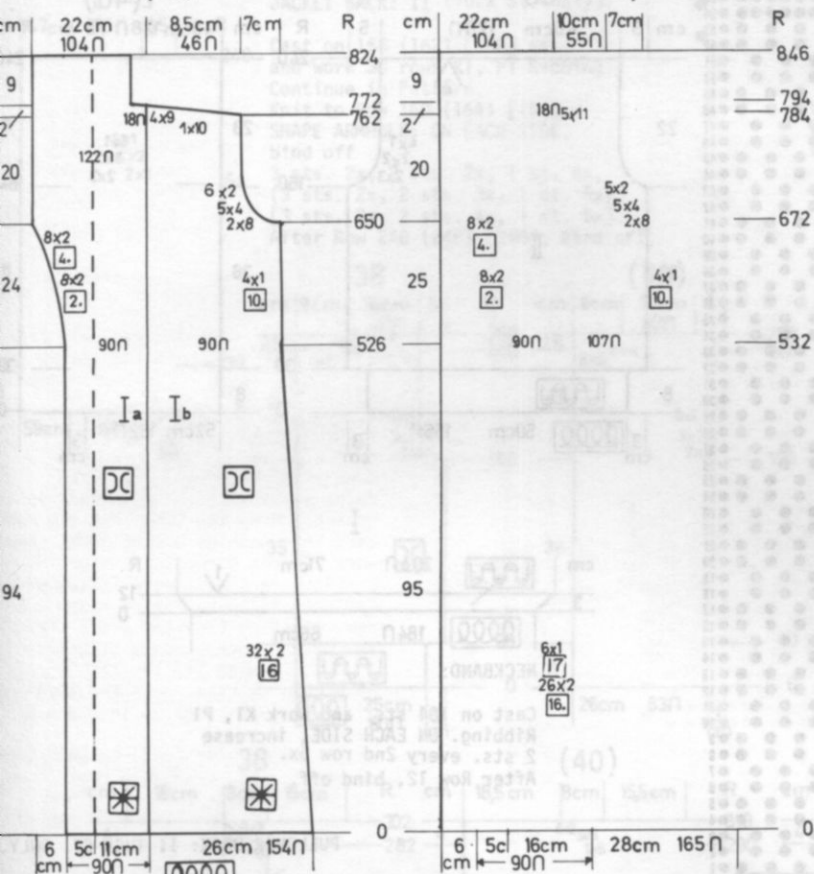

FRONT: Ib - Make 1, reverse 1.

Cast on 154 (165) sts. and work in Pattern.

ON SIDE EDGE, decrease 1 st.

every 16th row 32x.

(2 sts. every 16th row 26x,

1 st. every 17th row 6x).

After Row 526 (532) ON SIDE EDGE,

increase 1 st. every 10th row 4x.

After Row 650 (672), SHAPE ARMHOLE:

Bind off 8 sts. 2x, 4 sts. 5x,

2 sts. 6x.

(8 sts. 2x, 4 sts. 5x, 2 sts. 5x).

After Row 762 (784) SHAPE SHOULDER:

Bind off

10 sts. 1x, 9 sts. 4x.

(11 sts. 5x).

FRONT: Ia - Make 1, reverse 1.

Cast on 90 sts. and work in Pattern.

Knit to Row 525 (531).

SHAPE FRONT EDGE:

Increase 2 sts. every 2nd row 8x,

every 4th row 8x.

Knit to Row 772 (794).

Bind off 18 sts.

Knit to Row 824 (846) then bind off

the remaining 104 sts.

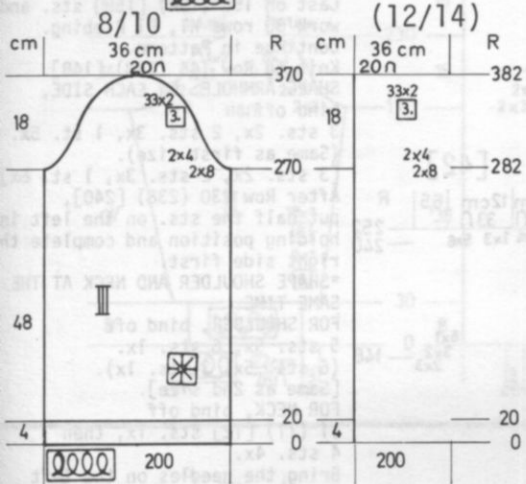

SLEEVES: III

Cast on 200 sts. and work in Pattern.

Knit to Row 270 (282).

SHAPE CAP: For both sizes, ON EACH

SIDE, bind off

8 sts. 2x, 4 sts. 2x, then on

every 3rd row, bind off

2 sts. 33x.

After Row 370 (382), bind off

the remaining sts.

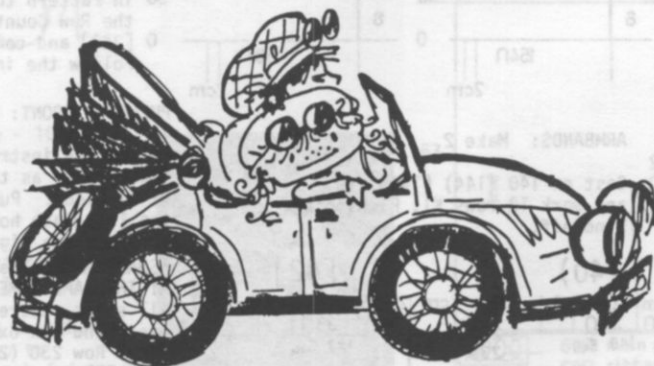
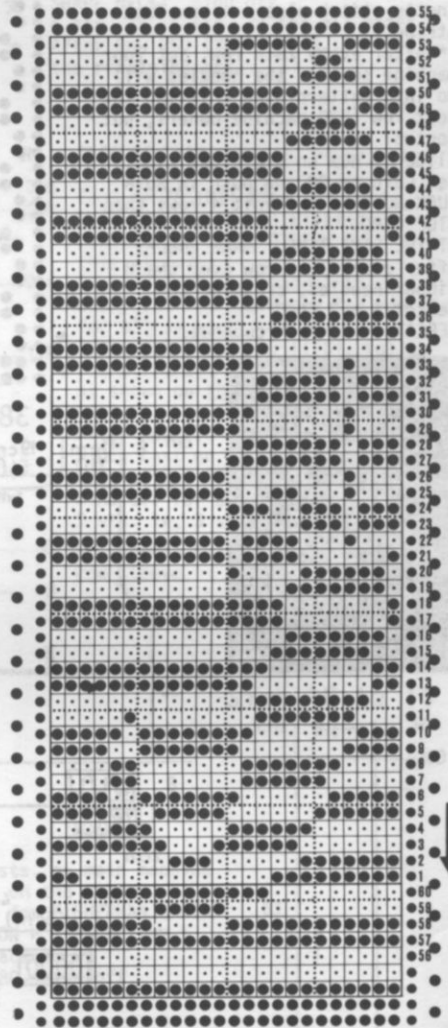

hp 733

MAN'S SLEEVELESS PULLOVER & JACKET

SIZES: 38 (40) [42]
 YARN: Vienna
 GRAMS: 650 700 750
 TENSION: 6 to 8
 GAUGE: 14 sts. 19 rows = 5 cm (2")

Stockinette stitch with a Cable Design and 4 rows Tuck Stitch on the fronts. The sleeves are in Tuck Pattern only. Bands are Ribbed. Use Card No. 2 for 830 machines or Punch your own Card.

FINISHING: See General Instructions. Sew in a Jacket type zipper.

PATTERN:

NEEDLE SET UP: *11 sts. on the main machine, 8 sts. on the Ribber. REPEAT across from *.
 The Pattern is a REPEAT of Stockinette stitch plus a 4 row Tuck Stripe.

** After every 29th row, set your machine so that the needles will go into pattern when knitting the next row (830 machine owners, put control on KC).

Slide is now on the right side. Set Card on GO and push in BOTH TUCK .BUTTONS and knit 4 rows then STOP CARD.

AT THE SAME TIME, MAKE CABLES after every 10th row over the 8 Ribber needles, crossing the center 3 + 3 sts. ** REPEAT from ** throughout.

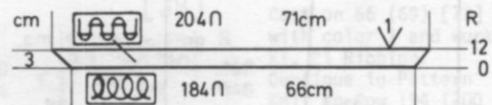
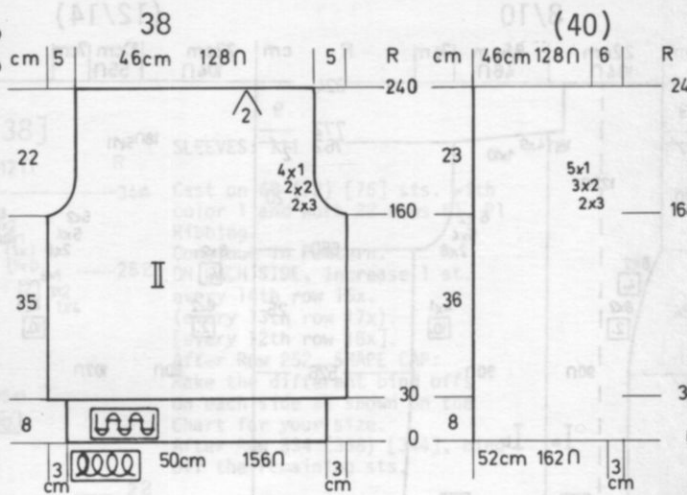
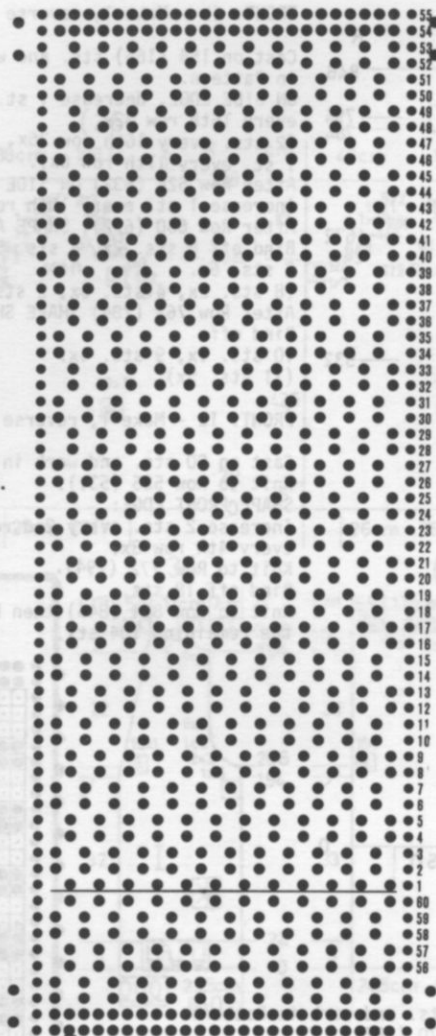

NECKBAND:

Cast on 184 sts. and work K1, P1 Ribbing. ON EACH SIDE, increase 2 sts. every 2nd row 5x. After Row 12, bind off.

PULLOVER BACK: II TUCK ST. ONLY.

Cast on 150 (154) [158] sts. and work 30 rows K1, P1 Ribbing. Continue in Pattern. Knit to Row 144 (148) [148]. SHAPE ARMHOLE: ON EACH SIDE, bind off 3 sts. 2x, 2 sts. 3x, 1 st. 5x. (Same as first size). [3 sts. 2x, 2 sts. 3x, 1 st. 6x] After Row 230 (238) [240], put half the sts. on the left in holding position and complete the right side first. *SHAPE SHOULDER AND NECK AT THE SAME TIME. FOR SHOULDER, bind off 5 sts. 5x, 6 sts. 1x. (6 sts. 5x, 3 sts. 1x). [Same as 2nd size]. FOR NECK, bind off 11 (11) [12] sts. 1x, then 4 sts. 4x. Bring the needles on the left into working position, knit 1 row in Pattern to the left side, turn the Row Counter back to 230 (238) [240] and complete the left half. Follow the instructions from *.

PULLOVER FRONT: I -Tuck & Cable

Follow the instructions (IN TUCK & CABLE) same as the back to Row 144 (148) [148]. Put half the sts. on the left into holding position and complete the right side first. *SHAPE ARMHOLE same as the back and AT THE SAME TIME, ON NECK SIDE, for all sizes, decrease 1 st. every 2nd row 6x, every 4th row 21x. After Row 230 (238) [240], SHAPE SHOULDER same as the back. Bring the needles on the left into working position, knit 1 row in Pattern to the left side, turn the Row Counter back to 144 (148) [148] and complete the left half. Follow the instructions from *

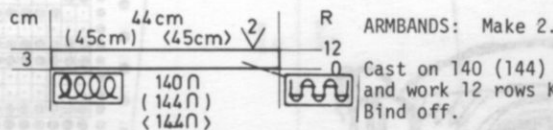
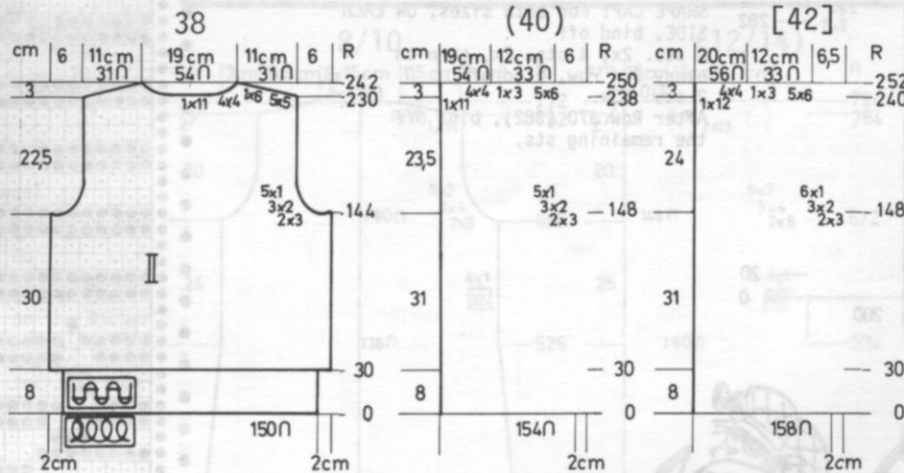

ARMBANDS: Make 2.

Cast on 140 (144) [144] sts. and work 12 rows K1, P1 Ribbing. Bind off.

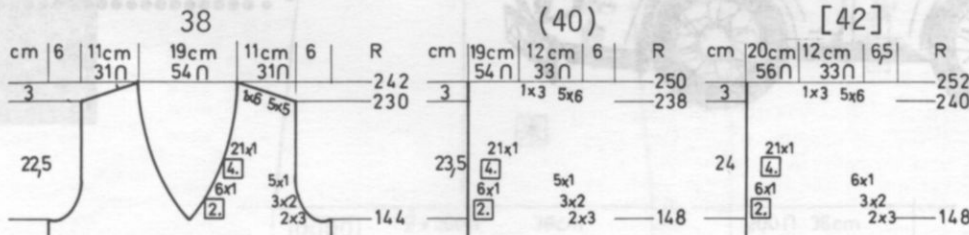

[42]

JACKET BACK: II (Tuck St. only).

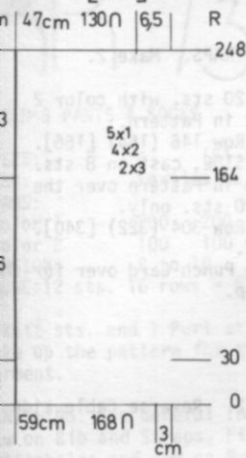

Cast on 156 (162) [168] sts. and work 30 rows K1, P1 Ribbing. Continue in Pattern. Knit to Row 160 (164) [164]. SHAPE ARMHOLE: ON EACH SIDE, bind off 3 sts. 2x, 2 sts. 2x, 1 st. 4x. (3 sts. 2x, 2 sts. 3x, 1 st. 5x). [3 sts. 2x, 2 sts. 4x, 1 st. 5x]. After Row 240 (248) [248], bind off.

COLLAR:

Cast on 36 (36) [38] sts. and work 200 rows Stockinette stitch. Bind off.

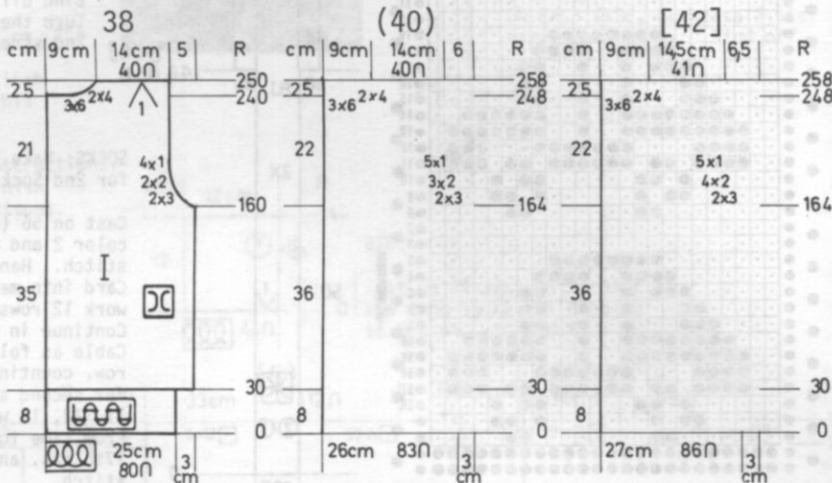
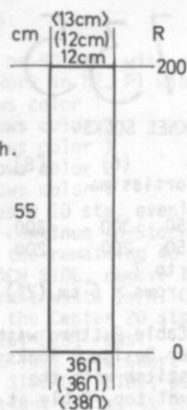

JACKET FRONT: I Make 1, reverse 1.

Cast on 80 (83) [86] sts. and work 30 rows K1, P1 Ribbing. Continue in Pattern. (Tuck & Cable) Knit to Row 160 (164) [164]. SHAPE ARMHOLE same as the back then knit to Row 241 (249) [249]. SHAPE NECK: Bind off 6 sts. 3x, 4 sts. 2x for all sizes. After Row 250 (258) [258], bind off the remaining sts.

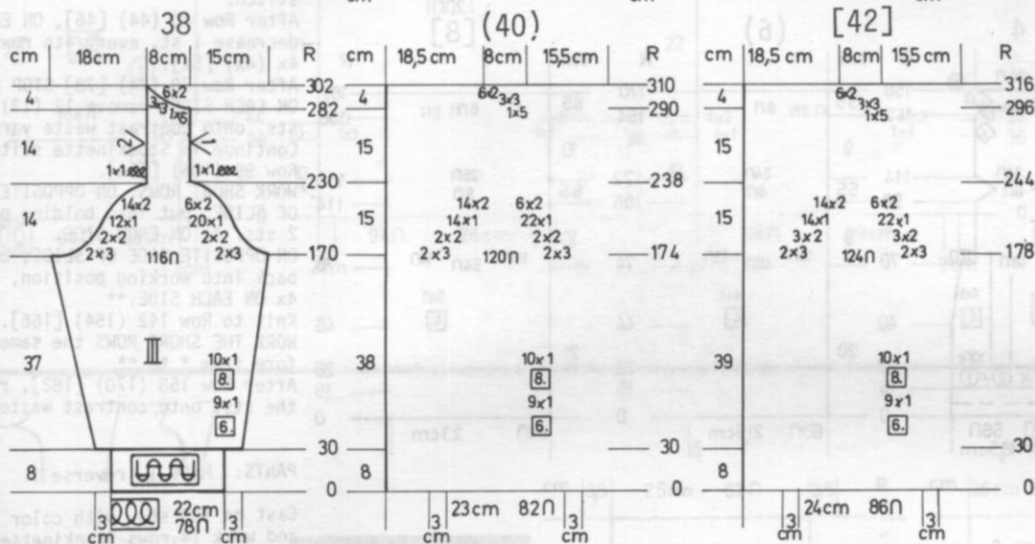

SLEEVES: III Make 1, reverse 1.

Cast on 78 (82) [86] sts. and work 30 rows K1, P1 Ribbing. Continue in TUCK PATTERN ONLY (see Picture). ON EACH SIDE, increase 1 st. every 6th row 9x, every 8th row 10x for all sizes. After Row 170 (174) [178], follow the different shapings ON EACH SIDE as shown on the Chart for YOUR SIZE. After Row 230 (238) [244], ON EACH SIDE, cast on 1 st. Knit to Row 282 (290) [296]. Bind off for all sizes, 5 sts. 1x, 3 sts. 3x, 2 sts. 6x. Be sure to REVERSE the shapings for 2nd sleeve.

DK 734

WOMAN'S VEST
 SIZE: 1 Size - 10 to 14
 YARN: Micaela
 STRINGS: 250
 LENGTH: 6 to 8
 GAUGE: 12 sts. 26 rows = 5 cm (2")



Finishing: Sew points together at sides (See picture) up to armhole opening. Attach fringe at lower edge using 8 to 10 strands approximately 11" long. Fold in half to make fringe 5 1/2".

Size 10 to 14

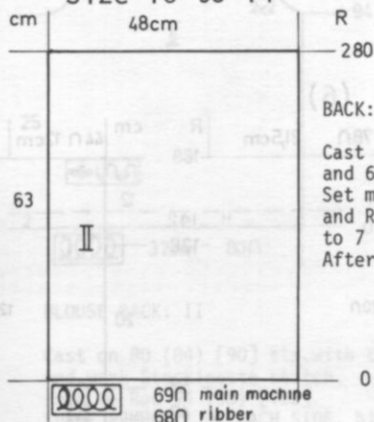

BACK: II

Cast on 69 sts. on main machine and 68 sts. on the Ribber. Set machine for FISHERMAN'S RIB and RIBBER ON H. RACK from 5 to 7 then back to 5. After Row 280, bind off.

Size 10 to 14

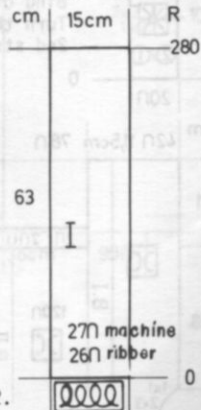

FRONT: Make 2.

Cast on 27 sts. on main machine and 26 on the Ribber. Knit in Pattern same as back to row 280, then bind off. Sew shoulders then follow finishing instructions.

KK 735

CHILD'S PANTS & KNEE SOCKS

SIZES: 4 (6) [8]
 YARN: Fortissima
 GRAMS: color 1 250 300 300
 color 2 150 200 200
 TENSION: 6 to 7
 GAUGE: 14 sts. 18 rows = 5 cm (2")

The Pants are a Cable Pattern with a Norwegian Border Design. Socks are Stockinette stitch with the Norwegian Design at top, Cable at side.

FINISHING: Fold the 8 sts. on each side of straps to the inside and sew in place then pin border trim onto pants (see picture). Sew center fronts and backs together then sew crotch seam. Sew trim in place after making lower hem. Sew straps to the inside of back or you can sew buttons onto straps and make loops on inside of back.
SOCKS: Sew back seam of socks then weave the open sts. of heel to the open sts. of leg. You can pull elastic through casing at top if needed.

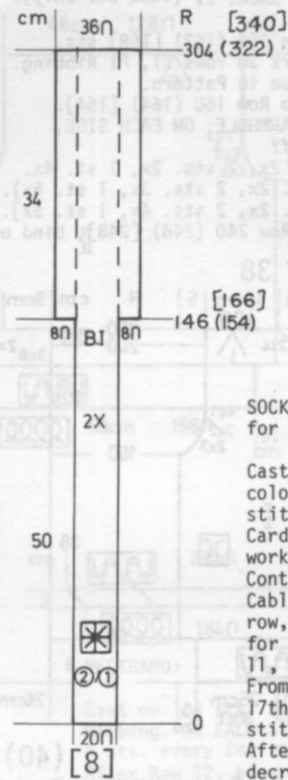
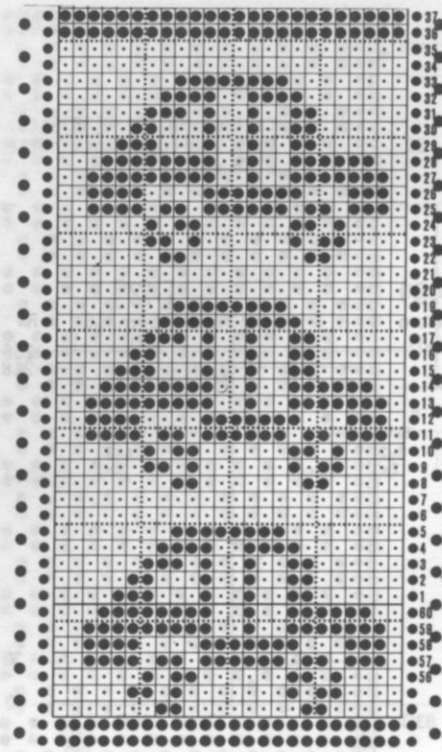

Cast on 20 sts. with color 2 and work in Pattern.
 Knit to Row 146 (154) [166].
 ON EACH SIDE, cast on 8 sts. Continue in Pattern over the center 20 sts. only.
 Knit to Row 304 (322) [340].
 Bind off.
 Turn the Punch Card over for 2nd strap.

SOCKS: Make 2. Reverse Cable side for 2nd Sock.

Cast on 56 (60) [64] sts. with color 2 and work 16 rows Stockinette stitch. Hang the hem. Put the Punch Card into machine UPSIDE DOWN, then work 12 rows Norwegian Design. Continue in Stockinette stitch with Cable as follows: After every 10th row, counting from the RIGHT (left for second sock), cross stitches 11, 12, 13 with 14, 15, 16. From time to time, drop the 10th and 17th sts. and latch up into a Rib stitch.

After Row 40 (44) [46], ON EACH SIDE decrease 1 st. every 4th row 4x (4x) [5x].

After Row 70 (74) [78] STOP CABLE. ON EACH SIDE, remove 12 (13) [14] sts. onto contrast waste yarn. Continue in Stockinette stitch to Row 98 (106) [114].

*WORK SHORT ROWS: ON OPPOSITE SIDE OF SLIDE, put into holding position 2 sts. 4x ON EACH SIDE.

ON OPPOSITE SIDE OF SLIDE, bring back into working position, 2 sts. 4x ON EACH SIDE.**

Knit to Row 142 (154) [166]. WORK THE SHORT ROWS the same as before from * to **.

After Row 158 (170) [182], remove the sts. onto contrast waste yarn.

PANTS: Make 1, reverse 1.

Cast on 100 sts. with color 1 and work 14 rows Stockinette stitch.

Beginning at back seam edge, set up the needles as follows. 4 sts. on Ribber, 4 on main machine, 4 on Ribber, 6 on main machine, 4 on Ribber, 6 on main machine, 4 on Ribber, 14 on main machine, 4 on Ribber, 6 on main machine, 4 on Ribber.

After EVERY 10th Row, CROSS THE STS. on the main machine. Continue in Pattern.

After Row 44 (48) [52], ON EACH SIDE, increase 1 st. 1x, 2 sts. 1x, 3 sts. 2x, 1 st. 1x.

(Same as first size). [1 st. 1x, 2 sts. 2x, 3 sts. 2x, 1 st. 1x].

Knit to Row 120 (128) [136]. Remove 78 (78) [80] on the RIGHT (left for 2nd section) onto contrast waste yarn.

Continue over the remaining stitches to Row 160 (168) [180] then bind off.

Pick up the sts. held on waste yarn and work 14 rows K2, P2 (or K1, P1) Ribbing. Bind off.

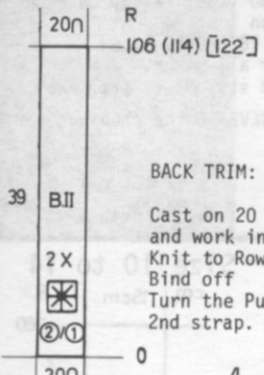
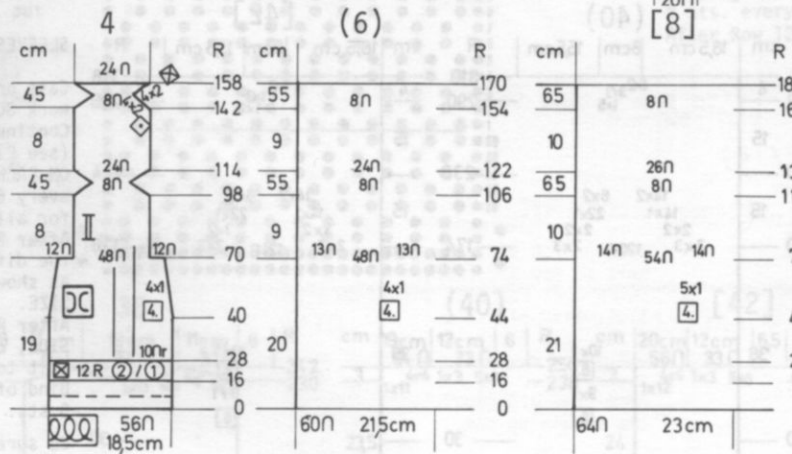

BACK TRIM: Make 2.

Cast on 20 sts. with color 2 and work in Pattern.
 Knit to Row 106 (114) [122].
 Bind off.
 Turn the Punch Card over for the 2nd strap.

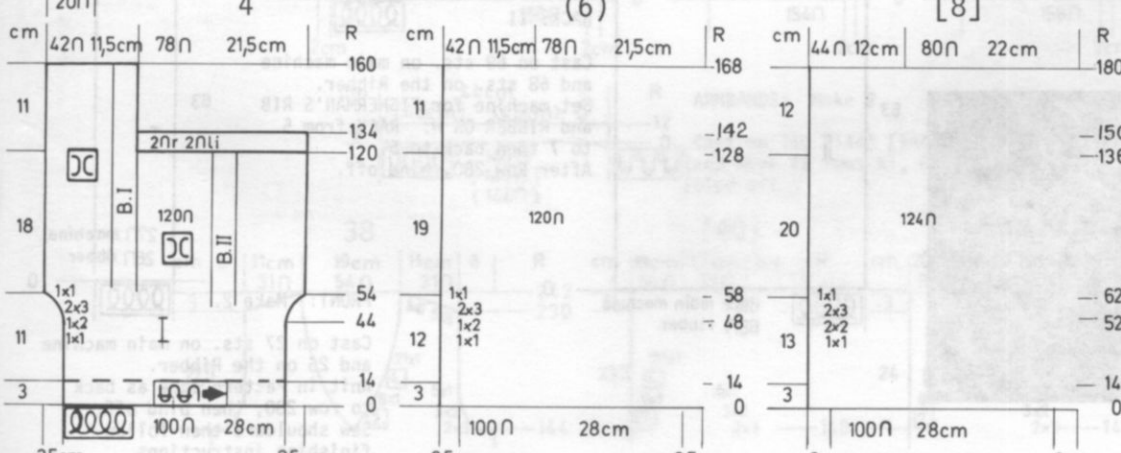

Remove 78 (78) [80] on the RIGHT (left for 2nd section) onto contrast waste yarn.

Continue over the remaining stitches to Row 160 (168) [180] then bind off.
 Pick up the sts. held on waste yarn and work 14 rows K2, P2 (or K1, P1) Ribbing. Bind off.

736

KID'S PANTS & SOCKS

SIZES: 4 (5) [6]
YARN: Fortissima
QUANTITIES:
 color 1 200 200 250
 color 2 100 100 150
CONVERSION: 8 to 10
GAUGE: 12 sts. 16 rows = 5 cm (2")



Knit sts. and 1 Purl stitch
 Make up the pattern for this
 garment.

FINISHING: See General Instructions.
 Sew on Bib and Straps. Finish
 Buttonholes and sew on Buttons.

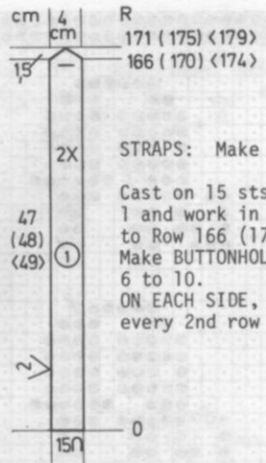

STRAPS: Make 2.

Cast on 15 sts. with color 1 and work in K2, P1 Ribbing to Row 166 (170) [174].
 Make **BUTTONHOLE** over needles 6 to 10.
ON EACH SIDE, decrease 2 sts. every 2nd row 3x. Bind off.

SOCKS:

Cast on 50 sts. with color 1 and work in K2, P1 Ribbing.
 6 rows color 1
 10 rows color 2
 10 rows color 1
 10 rows color 2
 10 rows color 1
 Decrease 10 sts. evenly across then continue in Stockinette stitch over the remaining 40 sts.
ON EACH SIDE, remove 10 sts. onto contrast waste yarn. Continue color 2. Over the Center 20 sts. knit 24 (26) [28] rows.
SHAPE TOE: Work Short Rows. **ON OPPOSITE SIDE OF SLIDE**, put into holding position, 2 sts. 4x **ON EACH SIDE**. **ON OPPOSITE SIDE OF SLIDE**, bring back into working position, 2 sts. 4x. Knit 24 (26) [28] rows.
 Work **SHORT ROWS** for **HEEL** in the same way as you did for toe, but put into holding 1 st. 6x then bring back 1 st. 6x.
 Remove onto contrast waste yarn. Weave heel and sides together.

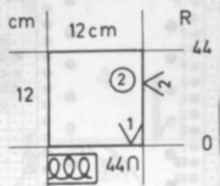

BIB:

Cast on 44 sts. with color 2 and work in K2, P1 Ribbing to Row 44. Bind off.

PANTS: Make 1, reverse 1.

Cast on 94 (94) [98] sts. with color 2 - 2 sts. on the main machine and 1 on the Ribber. Knit to Row 36.
 Change to color 1 and continue in Ribbing.
ON EACH SIDE, increase 1 st. 1x, then 2 sts. 3x (2 sts. 4x) [2 sts. 4x].
 After Row 115 (123) [129], put 48 (52) [51] sts. **OPPOSITE SLIDE** into holding position, then every 2nd row, put into holding position 12 (12) [13] sts. 5x.
 After Row 125 (133) [139], bring all the needles into working position, knit 1 row loosely then bind off.

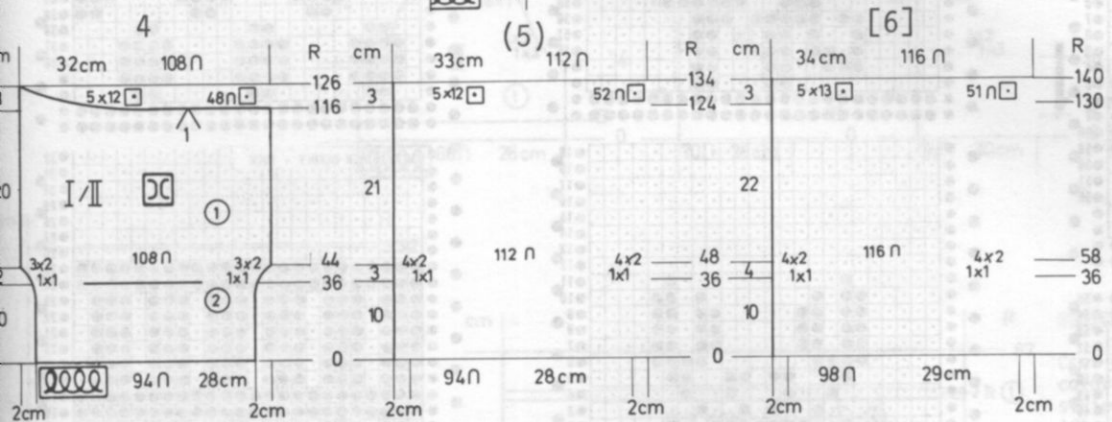

737

GIRL'S LONG DRESS & BLOUSE

SIZES: 4 (6) [8]
YARN: Fortissima
QUANTITIES:
 color 1 450 450 500
 color 2 200 200 250
 color 3 50 50 100
 color 4 50 50 100
 color 5 50 50 100
 color 6 50 50 100
CONVERSION: 7
GAUGE: 12 1/2 sts. 17 1/2 rows = 5 cm



The Blouse is Stockinette stitch worn on the purl side. Sleeve bands are Ribbed.

The Skirt is knitted sideways on the machine. Punch your own cards for the Norwegian Designs. Lower edge of Skirt is a Tuck pattern using every other needle.

FINISHING: See General Instructions.
SKIRT: Weave the open sts. together and remove waste yarn. Sew on border. Sew skirt to bodice. Run thread elastic through at waistline. Turn under hem at top and sew on straps.

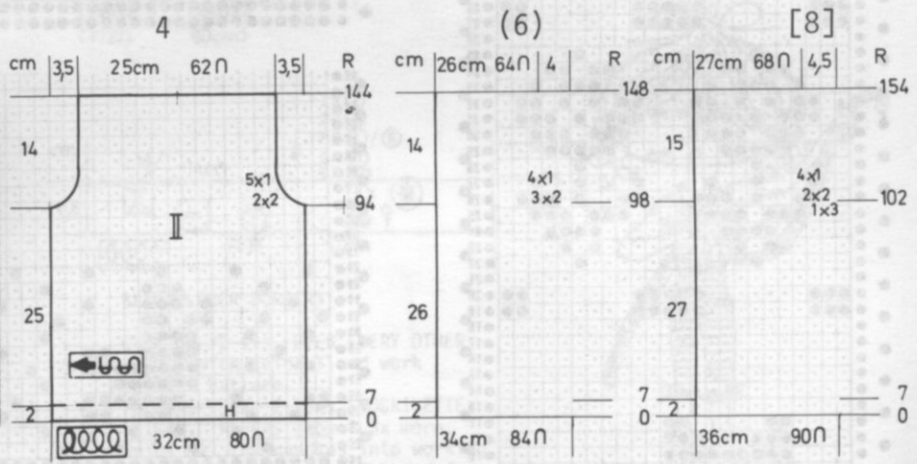

BLOUSE BACK: II

Cast on 80 (84) [90] sts. with color 1 and work Stockinette stitch. Knit to Row 94 (98) [102].
SHAPE ARMHOLE: **ON EACH SIDE**, bind off 2 sts. 2x, 1 st. 5x. (2 sts. 3x, 1 st. 4x). [3 sts. 1x, 2 sts. 2x, 1 st. 4x].
 After Row 144 (148) [154], bind off.

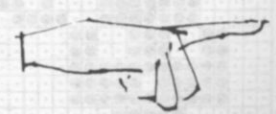

KK 737

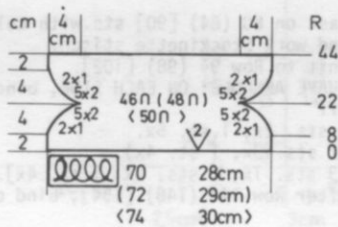
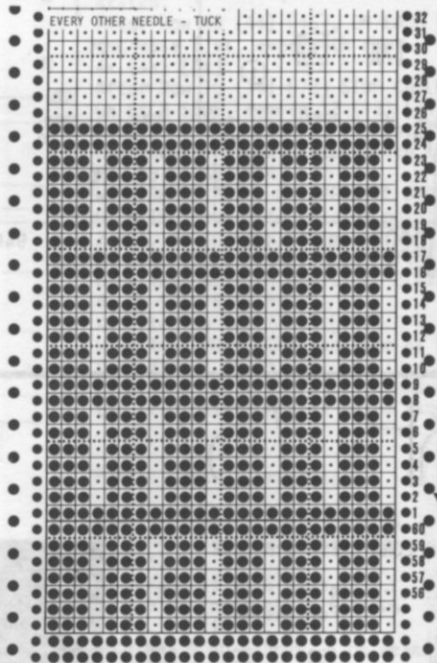
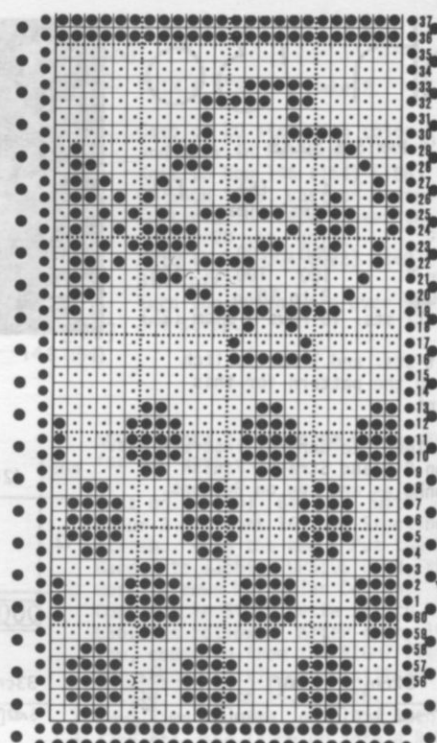
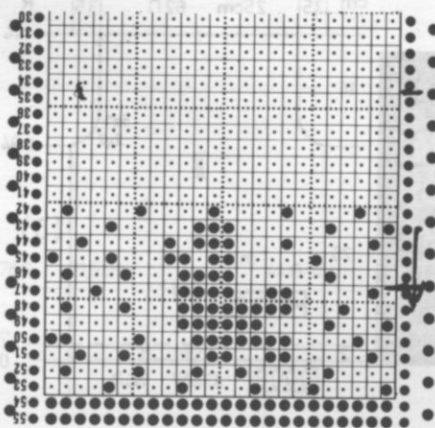
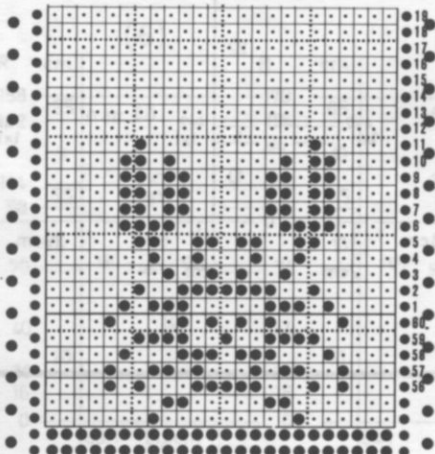
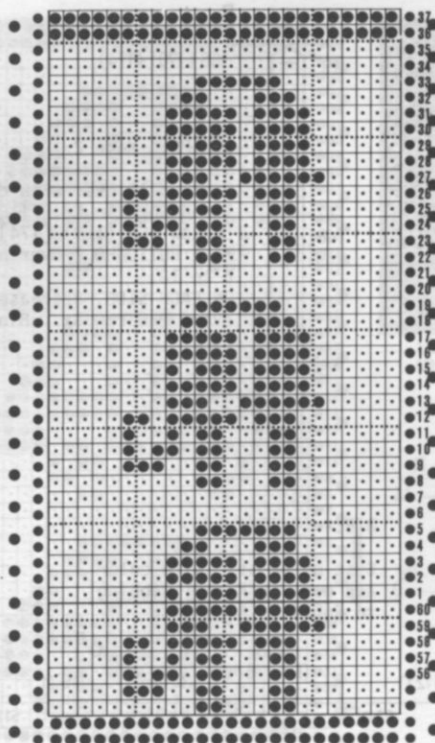
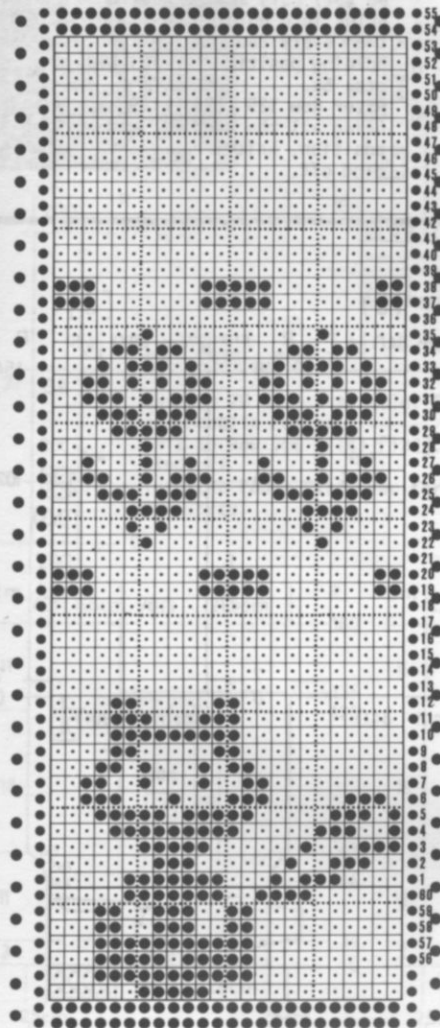
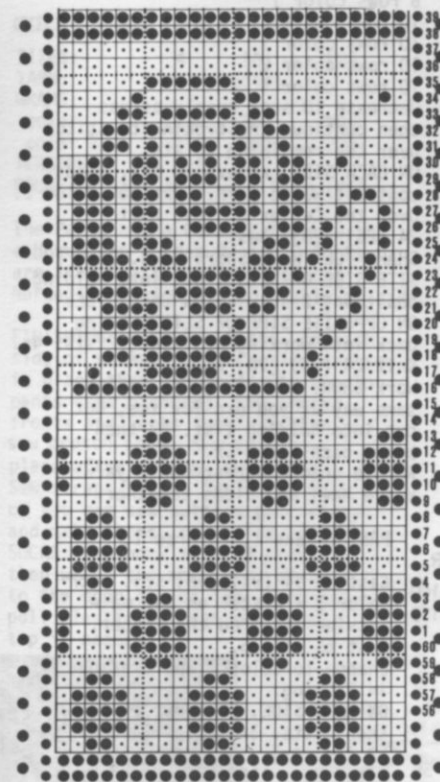

COLLAR:

Cast on 70 (72) [74] sts. with color 1 and work Stockinette stitch.
ON EACH SIDE, after Row 8, bind off 1 st. 2x, 2 sts. 5x.
 After Row 22, cast on 2 sts. 5x.
 1 st. 2x.
 After Row 44, bind off.

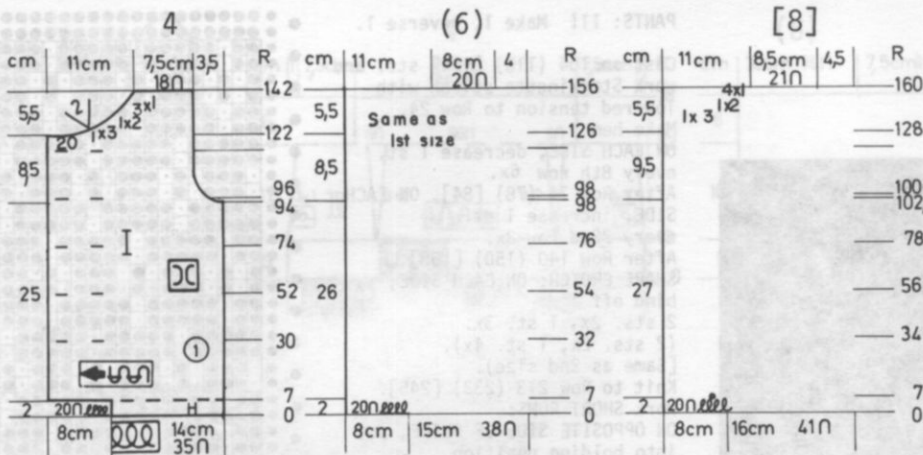

BLOUSE LEFT FRONT: I Make 1, reverse 1.

Cast on 35 (38) [41] sts. with color 1 and work Stockinette stitch. After Row 7, cast on 20 sts. for front band. (DO NOT make buttonholes in this section). After Row 14, make hem, then knit to Row 94 (98) [100]. SHAPE ARMHOLE same as the back then knit to Row 121 (125) [127]. SHAPE NECK: Bind off 20 sts. for all sizes then bind off 3 sts. 1x, 2 sts. 1x, 1 st. 3x. (Same as first size). [3 sts. 1x, 2 sts. 1x, 1 st. 4x]. After Row 142 (156) [160], bind off the remaining sts.

Work the right front in reverse, and - MAKE BUTTHOLES over needles 4 to 7 and 14 to 17 COUNTING FROM THE RIGHT EDGE after the rows shown on the Chart.

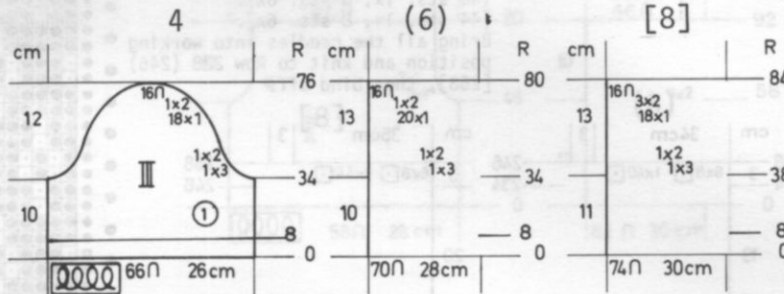

SLEEVES: III

Cast on 66 (70) [74] sts. with color 1 and work 8 rows K1, P1 Ribbing. Continue in Stockinette stitch. Knit to Row 34 (34) [38]. SHAPE CAP: ON EACH SIDE, bind off 3 sts. 1x, 2 sts. 1x, 1 st. 18x, 2 sts. 1x. (3 sts. 1x, 2 sts. 1x, 1 st. 20x, 2 sts. 1x). [3 sts. 1x, 2 sts. 1x, 1 st. 18x, 2 sts. 3x]. After Row 76 (80) [84], bind off the remaining sts.

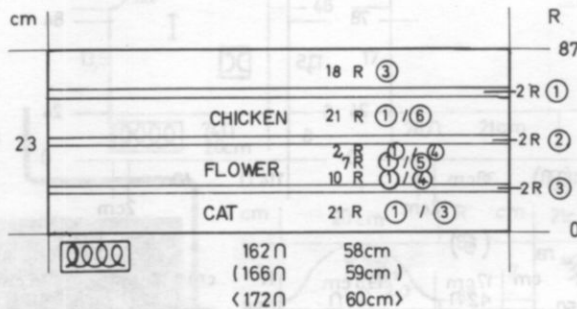

BODICE:

Cast on 162 (166) [172] sts. with color 1 and work in Pattern with stripes as shown on the Chart. After Row 88, bind off.

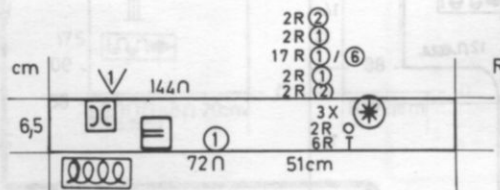

SKIRT LOWER BORDER:

Cast on 72 sts. OVER EVERY OTHER NEEDLE with color 1 and work in Tuck Pattern. *6 rows TUCK, 2 rows STOCKINETTE STITCH. REPEAT from * 3x more. Bring all the needles into working position and pick up a thread from row below to prevent a hole then continue to FOLLOW THE CHART for the color stripes and the Crab Pattern.

STRAPS:

Cast on 28 sts. with color 1 and work the Elephant Pattern to Row 140. Bind off.

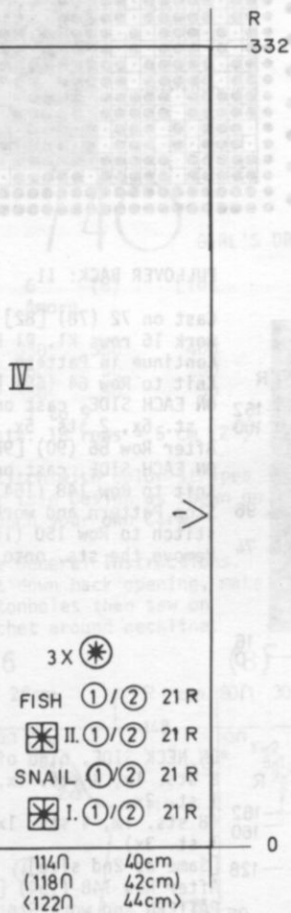

SKIRT: Begin and end with Waste Yarn.

Cast on 114 (118) [122] sts. with color 1 and work in Pattern as shown on the Chart. REPEAT 3x. After Row 332, remove onto contrast waste yarn.

KK 738

CHILD'S PULLOVER & PANTS

SIZES 4 (6) [8]
 YARN: Amore
 GRAMS: 300 350 400
 TENSION: 6 to 8
 GAUGE: 12 sts. 24 rows = 5 cm (2")

The Pants are Stockinette stitch and the Pullover is a Tuck Pattern. Punch your own card, push in BOTH Tuck Buttons. The Purl side is the right side. Waistband of Pullover is K1, P1 Ribbing.

FINISHING: See General Instructions. Work 1 row single crochet around neck and sleeves, then 1 row reverse single crochet. Remove the waste yarn.



PANTS: III Make 1, reverse 1.

Cast on 104 (110) [114] sts. and work Stockinette stitch with lowered tension to Row 24. Make hem.
 ON EACH SIDE, decrease 1 st. every 8th row 6x.
 After Row 74 (78) [84], ON EACH SIDE, increase 1 st. every 22nd row 3x.
 After Row 140 (150) [158], SHAPE CROTCH: ON EACH SIDE, bind off
 2 sts. 2x, 1 st. 3x.
 (2 sts. 2x, 1 st. 4x).
 [Same as 2nd size].
 Knit to Row 213 (233) [245].
 Work SHORT ROWS:
 ON OPPOSITE SIDE OF SLIDE, put into holding position,
 42 sts. 1x, 7 sts. 6x.
 (40 sts. 1x, 8 sts. 6x).
 [44 sts. 1x, 8 sts. 6x].
 Bring all the needles into working position and knit to Row 228 (246) [258], then bind off.

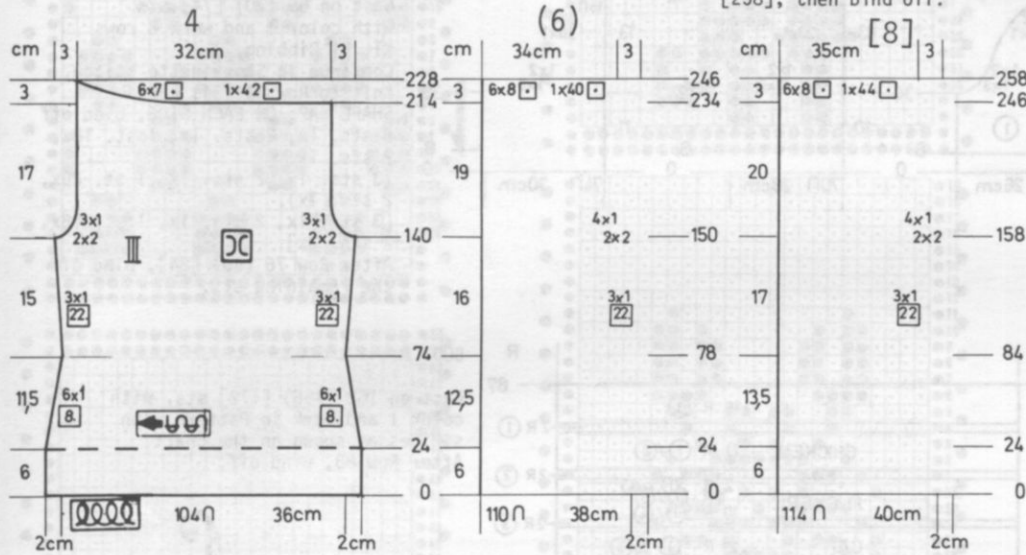
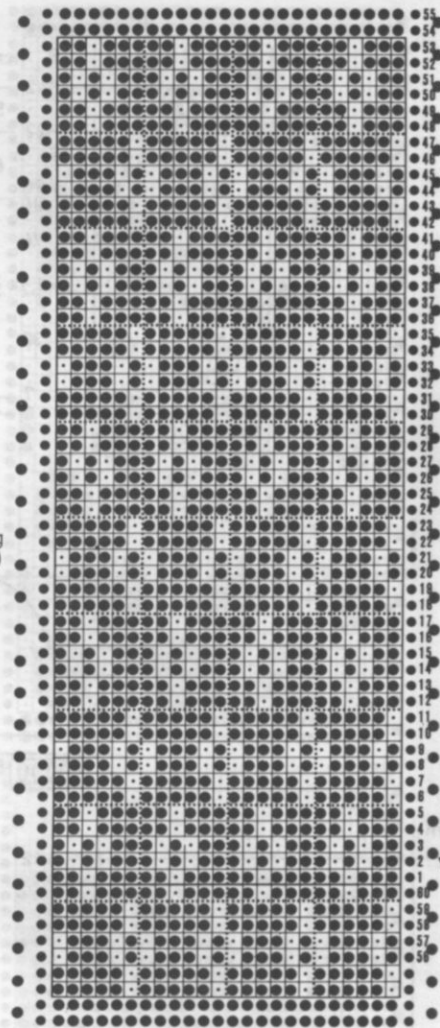

PULLOVER BACK: II

Cast on 72 (78) [82] sts. and work 16 rows K1, P1 Ribbing. Continue in Pattern
 Knit to Row 64 (68) [74].
 ON EACH SIDE, cast on 1 st. 6x, 2 sts. 5x.
 After Row 86 (90) [96].
 ON EACH SIDE, cast on 12 sts. Knit to Row 148 (154) [160].
 Stop Pattern and work Stockinette stitch to Row 150 (156) [162].
 Remove the sts. onto waste yarn.

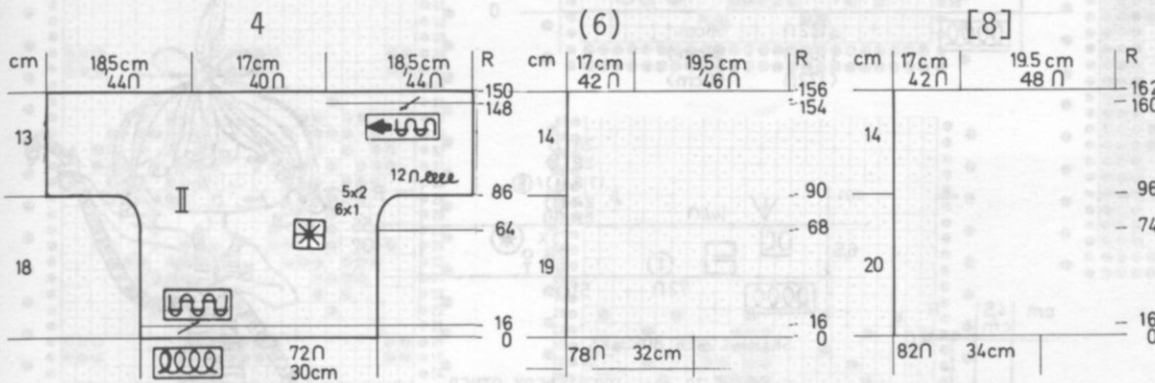

*ON NECK SIDE, bind off
 8 sts. 1x, 4 sts. 1x, 2 sts. 3x,
 1 st. 2x.
 (8 sts. 1x, 4 sts. 1x, 2 sts. 3x,
 1 st. 3x)
 [Same as 2nd size].
 After Row 148 (154) [160], STOP
 PATTERN and work Stockinette st.
 to Row 150 (156) [162] then
 remove the sts. onto contrast waste
 yarn.

PULLOVER FRONT: I

Work the front the same as the back to Row 116 (122) [128].
 SHAPE NECK: Put half the sts. on the left into holding position and complete the right side first.

Bring the needles on the left into working position, knit 1 row in Pattern to the left side, turn the Row Counter back to 116 (122) [128] and complete the left half. Follow the instructions from *.

739

GIRL'S SKIRT & TOP

SIZES: 4 (6)
YARN: Euro Sport
GRAMS:
 color 1 250 300
 color 2 50 50
 color 3 & 4 - small amounts not included in Kit.
TENSION: 8 to 10
GAUGE: 11 1/2 sts. 17 rows = 5 cm (2")

Stockinette stitch with K2, P2 Ribbing at lower edge and waistline of skirt. Stripes of color as given in the Instructions.

FINISHING: See General Instructions. Work 2 rows single crochet around edges and neckline.

Make 3 crochet ties as follows: Row 40, work 1 row single crochet down one side, then down the other side. Sew in place (see picture).

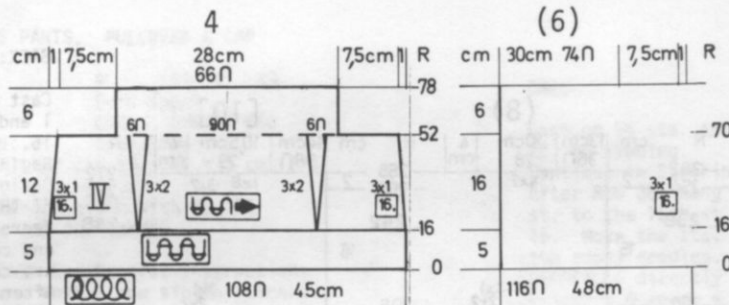

SKIRT: Make 2 sections.

Cast on 108 (116) sts. with color 1 and work 16 rows K2, P2 Ribbing. Continue in Stockinette stitch. SHAPE SIDES AND DARTS AT THE SAME TIME. ON EACH SIDE, decrease 1 st. every 16th row 3x and AT THE SAME TIME, for the DARTS on the same rows, Counting from each side of the center, hang the 22nd onto 23rd, the 25th onto 24th sts. and move the sts. in to fill the empty needles. The following dart decreases are made directly above. After Row 52 (70), decrease 24 sts. evenly across, knit 1 row stockinette stitch then continue in K1, P1 Ribbing. Work 6 rows color 1, 2 rows color 2, 22 rows color 1. Bind off.

FINISHING: See General Instructions. Work 2 rows single crochet around edges and neckline.

Make 3 crochet ties as follows: Row 40, work 1 row single crochet down one side, then down the other side. Sew in place (see picture).

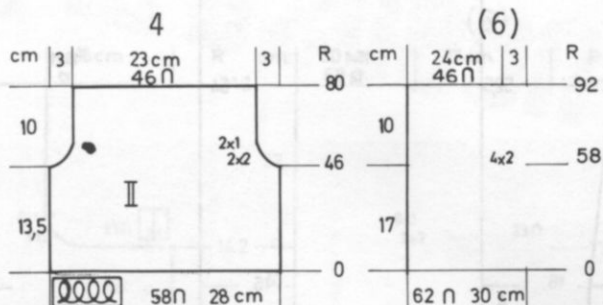

JACKET BACK: II

Cast on 58 (62) sts. with color 1 and work Stockinette stitch. *4 rows color 1, 2 rows color 2, REPEAT from * 2x more, then continue with color 1. After Row 46 (58) SHAPE ARMHOLE: ON EACH SIDE, bind off 2 sts. 2x, 1 st. 2x. (2 sts. 4x). After Row 80, (92) bind off.

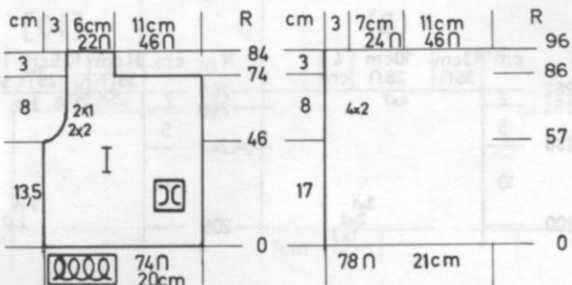

JACKET FRONT: I Make 1, reverse 1.

Cast on 74 (78) sts. with color 1 and work the Stockinette stitch with the color stripes same as the back. Continue in Color 1. After Row 45 (57) SHAPE ARMHOLE same as the back then knit to Row 74 (86). SHAPE NECK: Bind off 46 sts. for both sizes. Knit over the remaining 22 (24) sts. to Row 84 (96). Bind off.

740

GIRL'S DRESS

SIZES: 6 (8) [10]
YARN: Amore
GRAMS:
 color 1 350 350 400
 color 2 50 50 50
 color 3 50 50 50
TENSION: 7 to 9
GAUGE: 13 1/2 sts. 18 rows = 5 cm (2")

Stockinette stitch with color stripes and small Fair Isle Design as shown on the Chart. Punch your own Card.

FINISHING: See General Instructions. Single crochet down back opening, make loops for buttonholes then sew on buttons. Crochet around neckline.

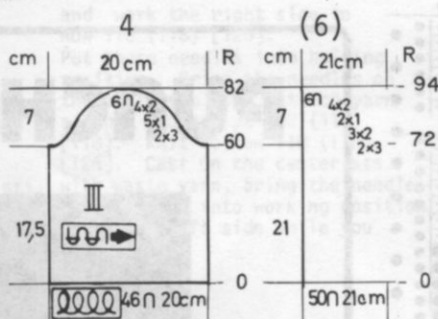

SLEEVES: III

With contrast waste yarn, cast on 46 (50) sts. After 8 to 10 rows, continue with color 1 and put Counter at 0. Work Stockinette stitch. Knit to Row 60 (72). SHAPE CAP: ON EACH SIDE, bind off 3 sts. 2x, 1 st. 5x, 2 sts. 4x. (3 sts. 2x, 2 sts. 3x, 1 st. 2x, 2 sts. 4x). After Row 82 (94), bind off the remaining sts.

Hang the open sts. of the sleeve back onto machine, then remove waste yarn. Work Stockinette stitch, 2 rows color 2, 6 rows color 3, 4 rows color 4. Bind off.

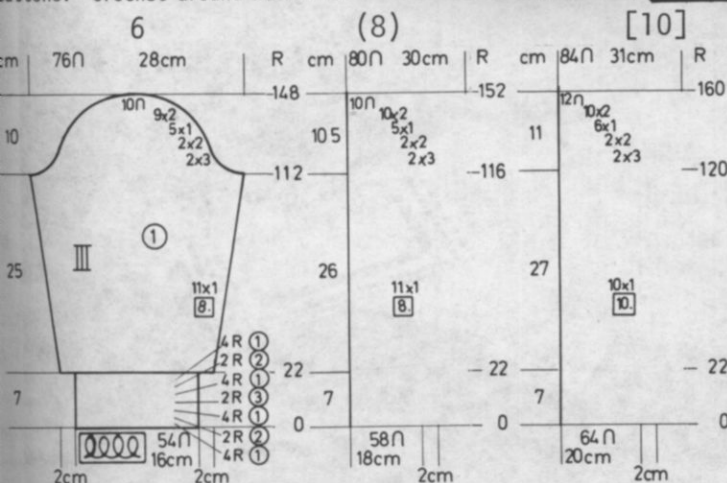

SLEEVES: III

Cast on 54 (58) [64] sts. with color 1 and work K1, P1 Ribbing with color stripes as shown on the Chart. After Row 22, continue in Stockinette with color 1 ON EACH SIDE, increase 1 st. every 8th row 11x. (every 8th row 11x). After Row 112 (116) [120], SHAPE CAP: ON EACH SIDE, bind off 3 sts. 2x, 2 sts. 2x, 1 st. 5x, 2 sts. 9x.

(3 sts. 2x, 2 sts. 2x, 1 st. 5x, 2 sts. 10x). [3 sts. 2x, 2 sts. 2x, 1 st. 6x, 2 sts. 10x]. After Row 148 (152) [160], bind off the remaining sts.



KK 740

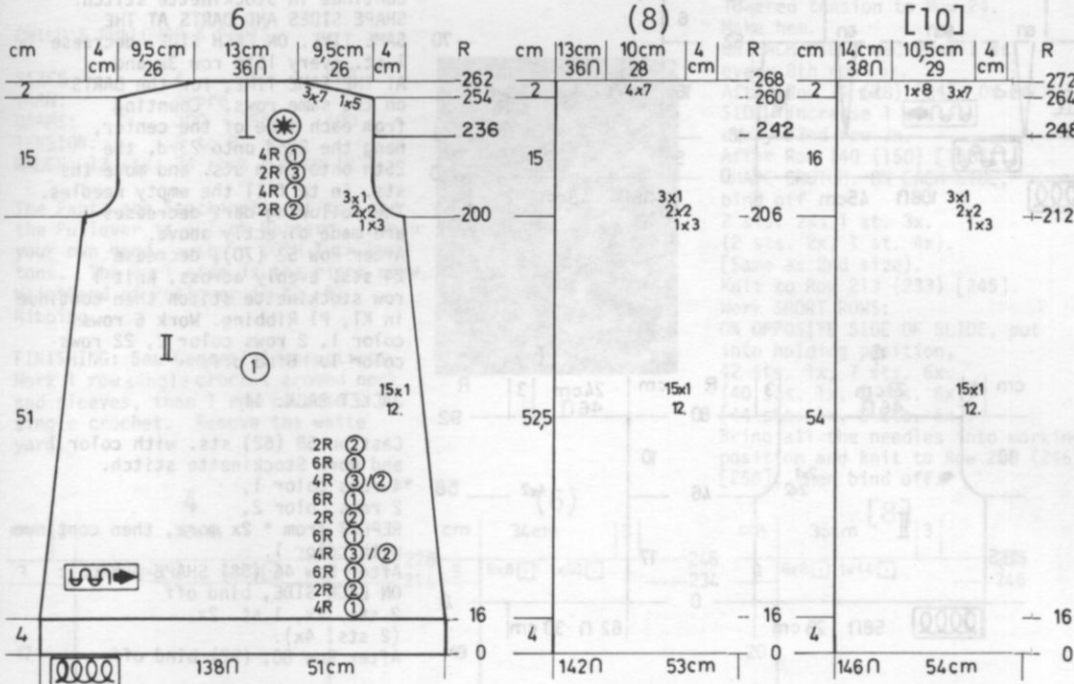

BACK: II

Cast on 138 (142) [146] sts. with color 1 and work Stockinette stitch to Row 16.

Begin the color stripes and Fair Isle Design as shown on the Chart. AT THE SAME TIME, ON EACH SIDE, decrease 1 st. every 12th row 15x and continue with color 1 when stripes are completed.

After Row 200 (206) [212], SHAPE ARMHOLE: ON EACH SIDE, bind off 3 sts. 1x, 2 sts. 2x, 1 st. 3x - for all sizes, working the color stripes. Continue with color 1 and Stockinette stitch. After Row 236 (242) [248], divide in the center, put half the sts. on the left into holding position and complete the right side first.

*Knit to Row 254 (260) [264].

SHAPE SHOULDER: Bind off

5 sts. 1x, 7 sts. 3x.

(7 sts. 4x).

[7 sts. 3x, 8 sts. 1x].

Bring the needles on the left into working position, knit 1 row to the left side, turn the Row Counter back to 236 (242) [248] and complete the left half. Follow the instructions from *.

FRONT: I

Work the front the same as the back to Row 200 (206) [212].

SHAPE ARMHOLE and work the color stripes same as the back then continue in Stockinette stitch with color 1 to Row 236 (242) [246].

Bind off the center 36 (36) [38] sts. for neck, put the sts. on the left into holding position and complete the right side first.

* Knit to Row 254 (260) [264] then SHAPE SHOULDER same as the back.

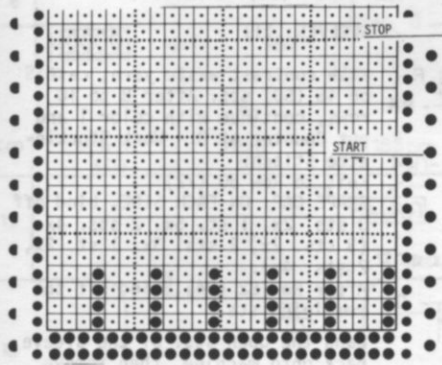
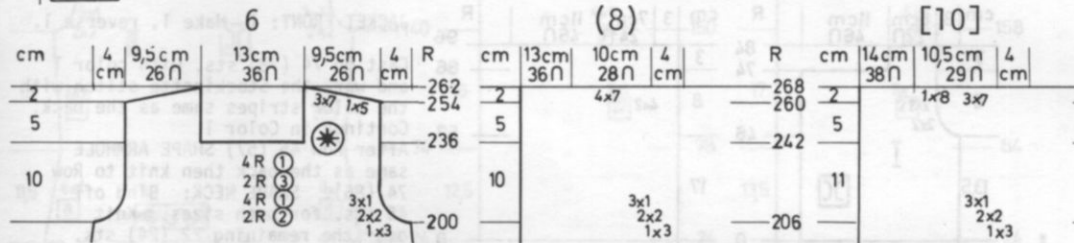

PUNCH your own CARDS

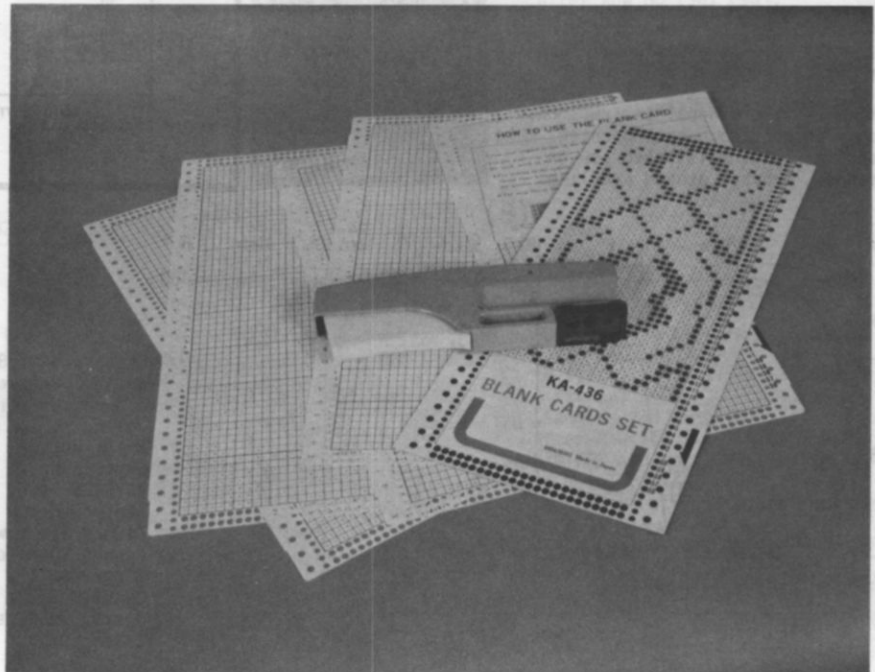

NEW TYPE PUNCHING TOOL...

\$14.95 (Calif. residents add Sales Tax).

\$ 1.25 Shipping Costs.

* * *

SET OF 10 BLANK CARDS with Instructions...

\$5.00 (Calif. residents add Sales Tax).

\$1.10 Shipping Costs.

CHILD'S PANTS, PULLOVER & CAP

SIZES: 4 (6) [8]
YARN: Euro Sport
GRAMS: 600 600 650
TENSION: 8 to 10
GAUGE: 11 1/2 sts. 17 rows = 5 cm (2")

Stockinette stitch with K2, P2 Ribbing for the Bands.

FINISHING: See General Instructions.
Pullover: Work 1 row single crochet and 1 row reverse single crochet around sleeves and bottom edge.
Cap: Sew up back seam then pull sts. together at top.

CAP:

Cast on 96 sts. and work 10 rows K2, P2 Ribbing. Continue in Stockinette stitch. After Row 38, hang every 14th st. to the 15th st. and 17th to 16. Move the sts. in to fill the empty needles. REPEAT THE DECREASES directly above after knitting 6 rows, 4 rows, 2 rows. After Row 52, remove the sts. onto strand of yarn and pull up and secure.

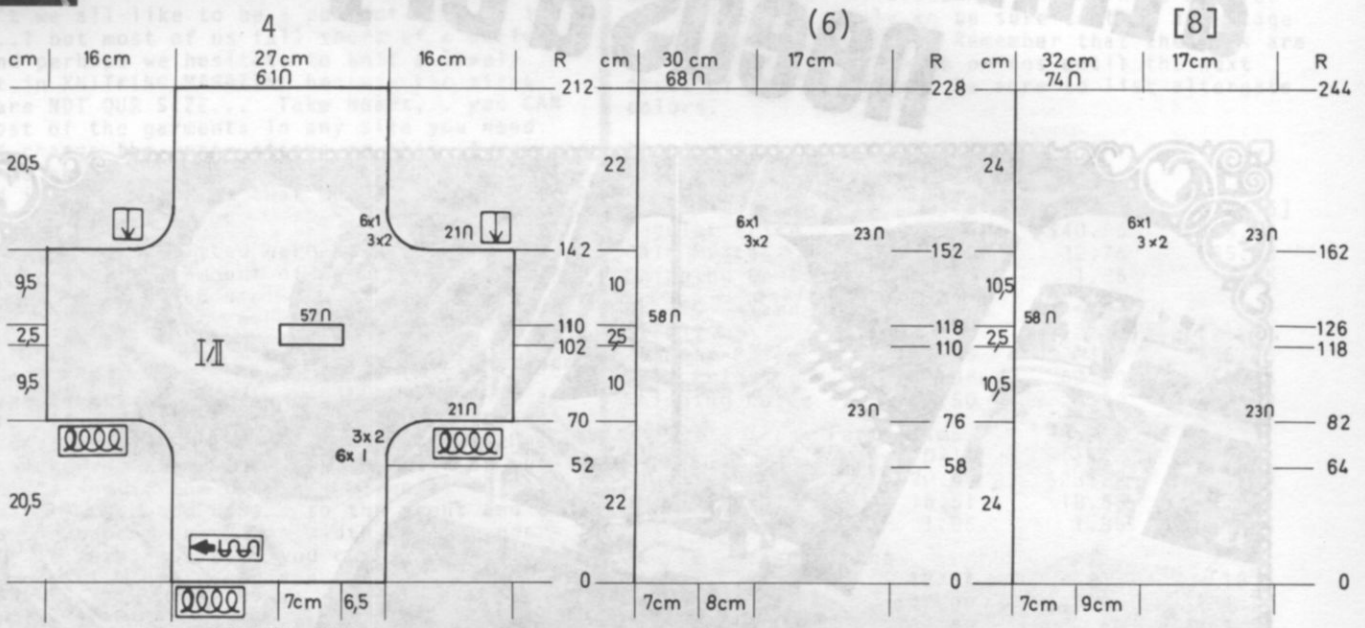

PULLOVER: I/11

Cast on 61 (68) [74] sts. and work Stockinette stitch. Knit to Row 52 (58) [64]. ON EACH SIDE, cast on 1 st. 6x, 2 sts. 3x, then cast on 21 (23) [23] sts. Knit to Row 102 (110) [118]. Remove the center 57 (58) [58] sts. onto waste yarn, put the needles on the left into holding position

and work the right side to Row 110 (118) [126]. Put these needles into holding position. Bring the needles on the left into work, attach yarn and put Counter at 102 (110) [118]. Knit to Row 110 (118) [126]. Cast on the center sts. with waste yarn, bring the needles on the right into working position (hold the left side while you

knit across to the right). Bring all the needles into working position then knit to Row 142 (152) [162]. ON EACH SIDE, bind off 21 (23) [23] sts. then bind off 2 sts. 3x, 1 st. 6x. Knit to Row 212 (228) [244]. Bind off. Hang the neck sts. of front back onto the machine and work 6 rows K2, P2. Bind off. Repeat for back neck.

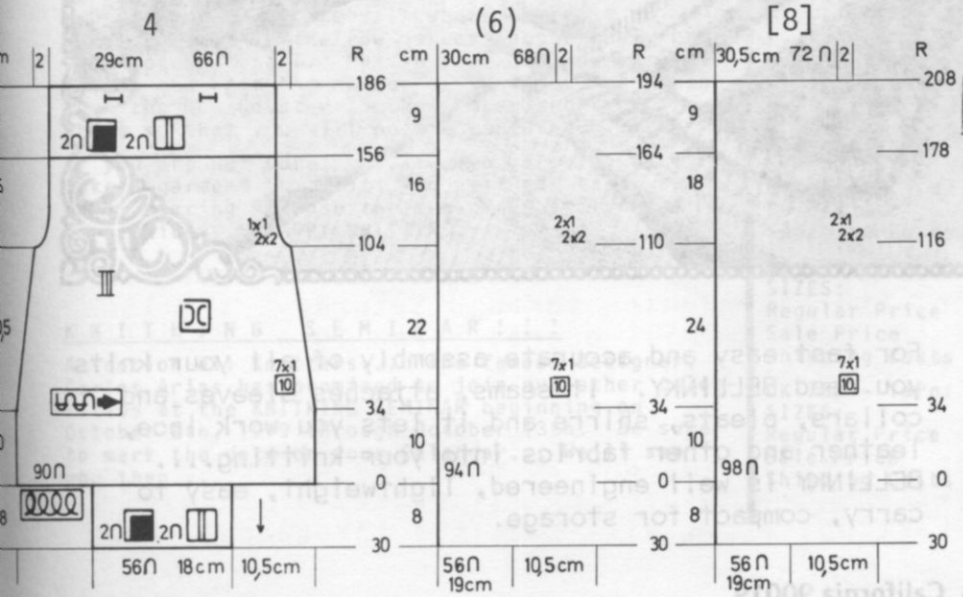

PANTS III Make 1, reverse 1.

With contrast waste yarn, cast on 90 (94) [98] sts. and knit 8 to 10 rows. Change to garment yarn and put Counter at 0. Continue in Stockinette stitch. After Row 34, ON EACH SIDE, decrease 1 st. every 10th row 7x. After Row 104 (110) [116], SHAPE CROTCH: ON EACH SIDE, bind off 2 sts. 2x, 1 st. 1x. (2 sts. 2x, 1 st. 2x). [2 sts. 2x, 1 st. 2x]. Knit to Row 156 (164) [178]. Continue in K2, P2 Ribbing to Row 186 (194) [208]. Bind off. Hang the open sts. back onto the machine, decreasing to 56 sts. Knit 1 row Stockinette stitch then continue in K2, P2 Ribbing for 30 rows. Bind off.

Your Knitter needs a Linker, like your Washer needs a Dryer

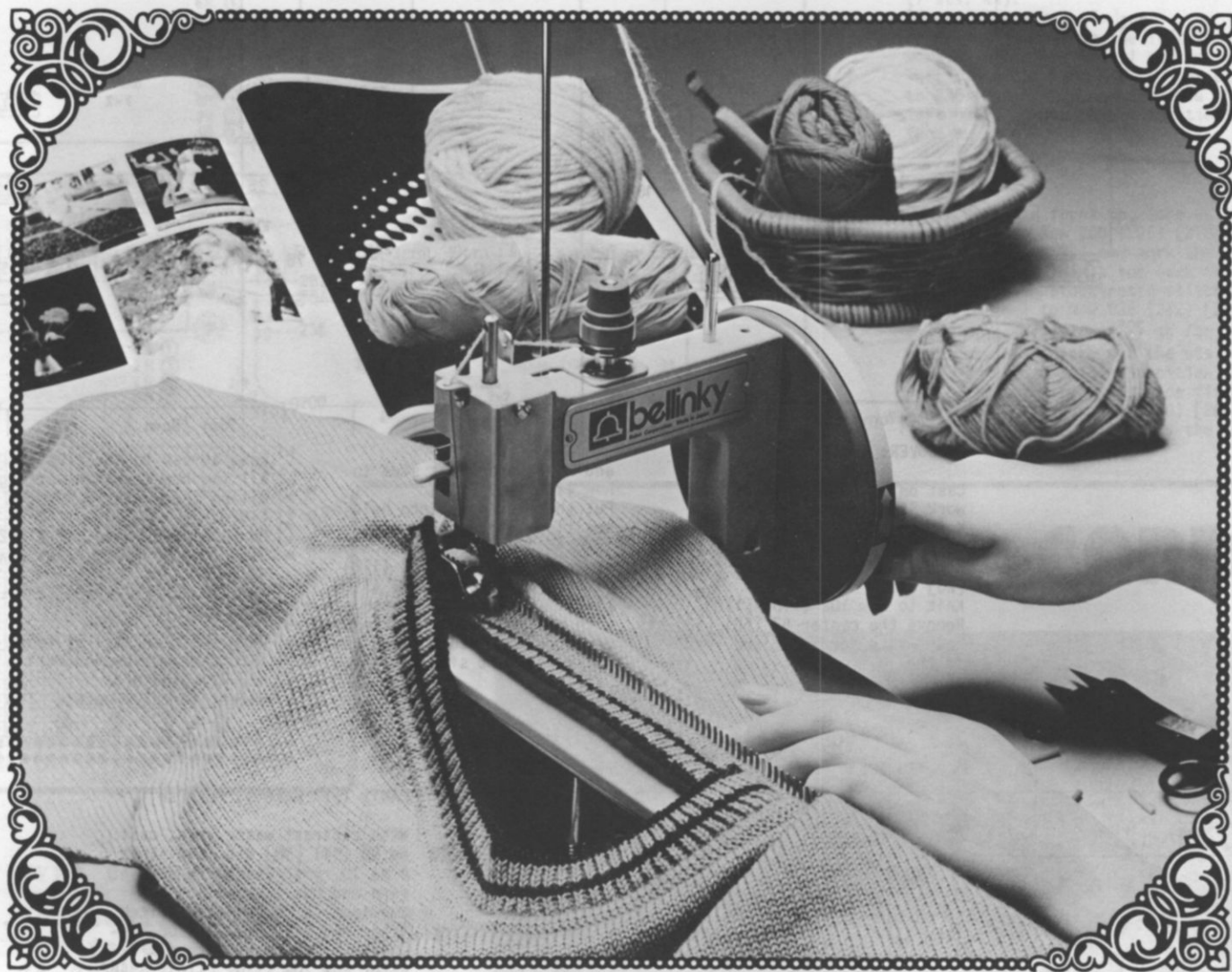

LINKING MACHINE
bellinky

Order direct from KNITKING

1128 Crenshaw Blvd., Los Angeles, California 90019

For fast easy and accurate assembly of all your knits you need BELLINKY. It seams, attaches sleeves and collars, pleats, shirrs and it lets you work lace, leather and other fabrics into your knitting.... BELLINKY is well engineered, lightweight, easy to carry, compact for storage.



KNITTING NEWS

PRACTICAL KNITTING HINTS

WHAT SIZE DO YOU WEAR?

Wouldn't we all like to be a perfect size 8, 10 or 12...? but most of us fall short of a perfect size and perhaps we hesitate to knit a lovely garment in KNITTING MAGAZINE because the sizes given are NOT OUR SIZE... Take heart... you CAN knit most of the garments in any size you need. You CAN change the instructions so that if you are a size 16 or 18 and the size given is 10/12 or 14 ... and it really is not that much of a problem to make the garment fit you.

As you must know, knitted garments should never fit tightly and the amount of ease depends on the STYLE and the yarn you use. An outer garment such as a Coat, Jacket, a Pullover worn over a Blouse, Vest, etc. should always have more ease allowance than a softly fitted dress for instance.

There are several ways to change the size of a garment. If you add or subtract 1" of stitches to the cast on for the front and 1" of stitches to the back, you have added 2" in width (or subtracted 2") and if the gauge is given as 16 sts. to 5 cm (2"), you add 8 sts. to the front and 8 sts. to the back. Check the width at the underarm. It is very possible, you can just follow the armhole bind offs as given, but if the width after the armhole bind off is too much (or too little), take half of the 8 sts. and bind off 2 extra sts. on each side with the first bind off. Divide the remaining sts. for binding off at the shoulders and neckline - 1 st. for each shoulder and 2 sts. at neck. A good thing to remember however, when the garment is in a Pattern Stitch, try to add or subtract either a complete pattern or half a pattern so that you can match the side seams.

ROWS: - you can wear a size 8 and be 6 feet tall or you can be 4 feet tall. A size 18 or 20 can be very short or very tall and so you must check the complete length of any garment. You may have to add or subtract rows. Always try to add or subtract rows at intervals where there is no shaping. Change the row numbers accordingly on your pattern chart. Put in your own row numbers or you can knit the number of rows you need then turn the Row Counter to the number shown on the Chart so that you will not be confused.

If you are not sure what size you should knit, take a garment that fits you well and that you enjoy wearing and use the measurements from it as a guide.... HAPPY KNITTING.

KNITTING SEMINAR!!!

Attention all Knitters... The famous Designer, Carlos Arias has promised to join our other celebrities at the KNITTING SEMINAR beginning on October 8th, 1979 through October 13th. Be sure to mark the date on your Calendar... We'll see you then....

The following is a list of the Yarn Kits available for the garments in this issue of KNITTING MAGAZINE. The special discounts on the Kits are for our subscribers only so be sure to take advantage of the special prices. Remember that the Kits are only available at these prices until the next issue of the magazine. Be sure to list alternate colors.

DISCOUNTED KITS FOR THIS ISSUE

DK 719 - Yarn: Crocus Crepe			
SIZES:	8/10	(12)	[14/16]
Regular Price	\$37.80	\$40.95	\$44.10
Sale Price	30.24	32.76	35.28
Shipping Costs	1.85	1.85	1.85
DK 720 - Yarn: Crocus Crepe			
SIZES:	8/10	(12/14)	[16]
Regular Price	\$72.45	\$78.75	\$85.05
Sale Price	57.96	63.00	68.04
Shipping Costs	2.50	2.50	2.50
DK 721 - Yarn: Fortissima			
SIZES:	10/12	(14)	[16]
Regular Price	\$20.64	\$23.22	\$25.80
Sale Price	16.51	18.58	20.64
Shipping Costs	1.85	1.85	1.85
DK 722 - Yarn: Vienna			
SIZES:	12/14	(16)	[18]
Regular Price	\$47.00	\$47.00	\$51.70
Sale Price	37.60	37.60	41.36
Shipping Costs	1.85	1.85	2.50
DK 723 - Yarn: Crocus Crepe and Euro Sport			
SIZES:	8/10	(12)	[14]
Regular Price	\$42.00	\$46.90	\$50.05
Sale Price	33.60	37.52	40.04
Shipping Costs	1.85	1.85	1.85
DK 724 - Yarn: Fortissima			
SIZES:	12/14		
Regular Price	\$36.12		
Sale Price	28.90		
Shipping Costs	1.85		
HP 725 - Yarn: Vienna			
SIZES:	34/36	(38)	[40]
Regular Price	\$23.50	\$23.50	\$25.85
Sale Price	18.80	18.80	20.68
Shipping Costs	1.85	1.85	1.85
DK 726 - Yarn: Venetia plus (thread or monofil not included in Kit.)			
SIZES:	6/8	(10)	[12]
Regular Price	\$49.60	\$49.60	\$49.60
Sale Price	39.68	39.68	39.68
Shipping Costs	2.25	2.25	2.25
DK 727 - Yarn: Fortissima			
SIZES:	10	(12)	[14]
Regular Price	\$41.28	\$43.86	\$46.44
Sale Price	33.03	35.09	37.15
Shipping Costs	1.85	1.85	1.85
DK 728 - Yarn: Vienna			
SIZES:	8/10	(12)	[14]
Regular Price	\$47.00	\$47.00	\$51.70
Sale Price	37.60	37.60	41.36
Shipping Costs	1.85	1.85	2.50

HP 729 - Yarn: Fortissima			
SIZES:	34/36	(38/40)	
Regular Price	\$36.12	\$43.86	
Sale Price	28.90	35.09	
Shipping Costs	1.85	1.85	
DK 730 - Yarn: Space Dyed and Vienna			
SIZES:	12	(14)	[16]
Regular Price	\$43.86	\$43.86	\$46.21
Sale Price	35.08	35.08	36.90
Shipping Costs	3.35	3.35	3.35
DK 731 - Yarn: Micaela			
SIZES:	8/10	(12/14)	
Regular Price	\$59.54	\$64.12	
Sale Price	47.63	51.30	
Shipping Costs	2.50	2.50	
HP 732 - Yarn: Fortissima			
SIZES:	34	(36)	[38]
Regular Price	\$38.70	\$43.86	\$49.02
Sale Price	30.96	35.09	39.22
Shipping Costs	1.85	1.85	1.85
HP 733 - Yarn: Vienna			
SIZES:	38	(40)	[42]
Regular Price	\$30.55	\$32.90	\$35.25
Sale Price	24.44	26.32	28.20
Shipping Costs	1.85	1.85	1.85
DK 734 - Yarn: Micaela			
SIZES:	10 to 14		
Regular Price	\$11.45		
Sale Price	9.16		
Shipping Costs	1.85		
KK 735 - Yarn: Fortissima			
SIZES:	4	(6)	[8]
Regular Price	\$20.64	\$25.80	\$25.80
Sale Price	\$16.51	\$20.64	\$20.64
Shipping Costs	1.85	1.85	1.85

KK 736 - Yarn: Fortissima			
SIZES:	4	(5)	[6]
Regular Price	\$15.48	\$15.48	\$20.64
Sale Price	12.39	12.39	16.51
Shipping Costs	1.85	1.85	1.85
KK 737 - Yarn: Fortissima			
SIZES:	4	(6)	[8]
Regular Price	\$43.86	\$43.86	\$59.34
Sale Price	35.09	35.09	47.47
Shipping Costs	1.85	1.85	2.50
KK 738 - Yarn: Amore			
SIZES:	4	(6)	[8]
Regular Price	\$12.70	\$14.35	\$16.40
Sale Price	9.84	11.48	13.12
Shipping Costs	1.85	1.85	1.85
KK 739 - Yarn: Euro Sport			
SIZES:	4	(6)	
Regular Price	\$10.50	\$12.25	
Sale Price	8.40	9.80	
Shipping Costs	1.85	1.85	
KK 740			
SIZES:	6	(8)	[10]
Regular Price	\$18.45	\$18.45	\$20.50
Sale Price	14.76	14.76	16.40
Shipping Costs	1.85	1.85	1.85
KK 741 - Yarn Euro Sport			
SIZES:	4	(6)	[8]
Regular Price	\$21.00	\$21.00	\$22.75
Sale Price	16.80	16.80	18.20
Shipping Costs	1.85	1.85	1.85



knitking announces their

SEMINAR

and open house

1979



On the premises at 1128 Crenshaw Blvd., Los Angeles, Calif. 90019... Commencing Monday, October 8th and running through Saturday, the 13th. During the five weekdays the Seminar will operate from 10 a.m. until 4 p.m., and on Saturday from 10 a.m. until 1 p.m.

Admission will be FREE - Coffee and Doughnuts will be available at 9:30 a.m. daily. Plan to be with us and to meet the knitting experts at KNITKING. Classes and Lectures on all phases of machine knitting - Measuring - Charting, etc., will continue throughout every day.

1128 Crenshaw Blvd., Los Angeles, California 90019

KNITTING fights INFLATION!

SAVE \$134.00

on a baby lock EA 605

Volume purchasing combined with the strengthening of the U.S. dollar, allows us to reduce the price of the fabulous Cut-Sew Overlock - Model EA 605 to below \$300.00 for the first time in several years. The regular price of this handsome 'BABY' is \$429.00... Use it for that professional finish on all your sewing... and to assemble your knits... Take advantage of our inflation fighting price now... We cannot guarantee to repeat this LOW, LOW PRICE.

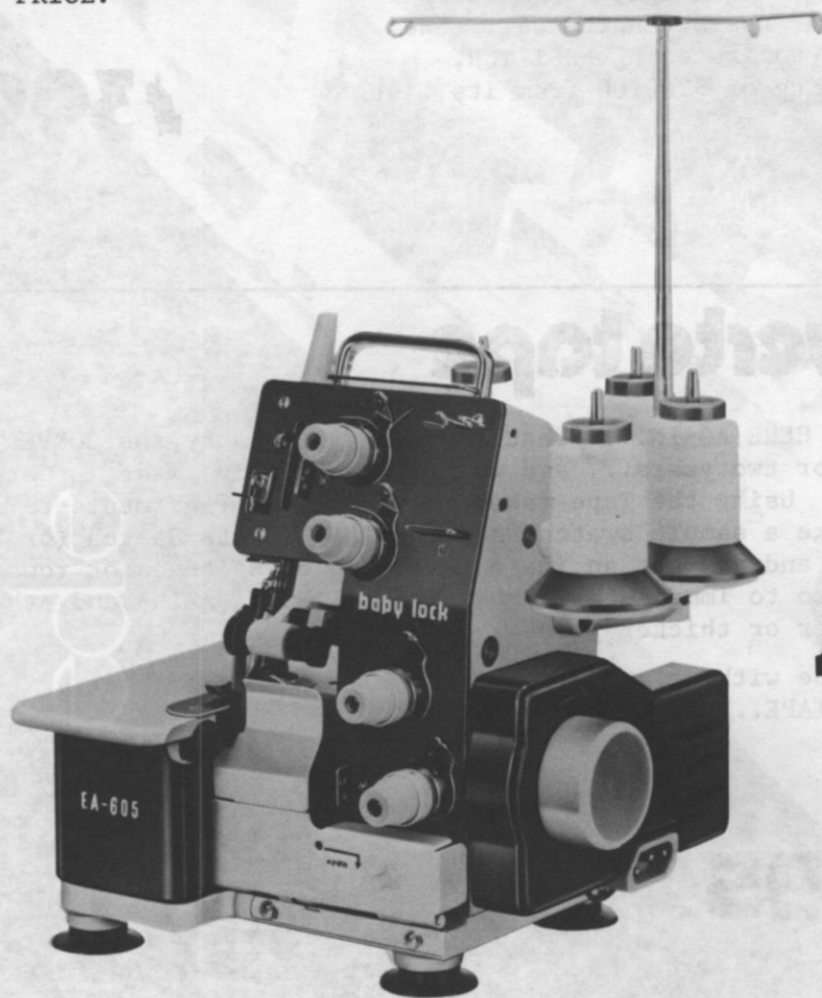

\$295

Order direct from

knitking

1128 Crenshaw Boulevard, Los Angeles, California 90019

SAVE \$200.00

baby blind stitch sewing machine

At the end of 1978 the manufacturers price to us almost doubled... We fought for a lower price and the dollar has strengthened... We can now offer this top-rated BLINDSTITCH, Model 606 at a saving of \$200.00 from its list price of \$599.00.



\$399

converta tape

CONVERTA TAPES ARE HERE AGAIN!!! That marvelous Accessory the CONVERTA TAPE has been unavailable for two years... and we have them again, made in Germany to the original design... Using the Tape makes the charting of garments to size ten times easier... Just make a sample swatch, set the Tape to its Stitch (or Row) Gauge, measure the person and you get an instant reading of stitches or rows needed... Use a Converta Tape also to immediately convert KNITTING MAGAZINE and other patterns for use with thinner or thicker yarns.

NO knitter should be without a
KNITTING CONVERTA TAPE...

\$15.95

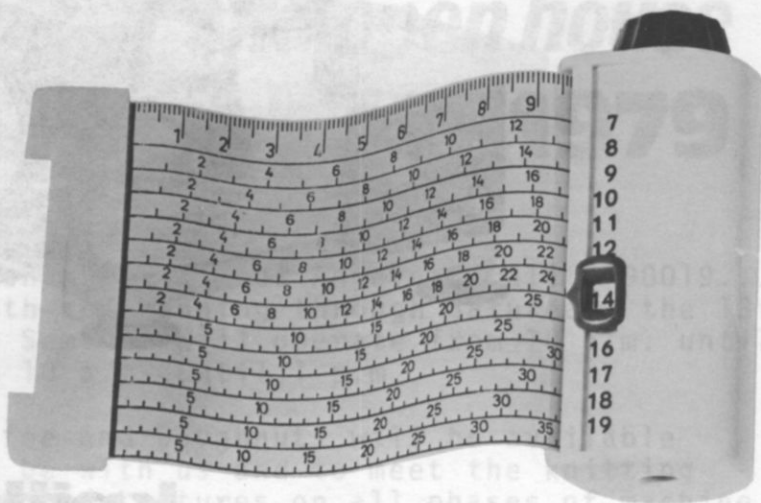

Calif. residents add Sales Tax.
Shipping Costs \$1.25

Order direct from KNITTING — 1128 Crenshaw Blvd., Los Angeles, California 90019

... it's new from Knitking
The KH-120\258
fine needle
knitter

Especially for
fine yarn...
(from crochet thread to
to sport yarn)

With the new
LACEMAKER that makes
exquisite fine lace as
well as
standard lace.

The **KH-120** has Twin Yarn
Feeders and Push Button Pattern
Selection for an unlimited
number of fancy stitches.

Ideal knitter for large people.

With 258 needles, the **KH-120** will
knit 32 inches wide when knitting 8 stitches
per inch... 200 needle machines can only
knit 25 inches wide at the same stitch gauge.

You can use your **KNITLEADER** with the **KH-120**.

There is a 258 needle **RIBBER ATTACHMENT** available.
You can actually rib with a fine yarn over as many as
516 needles for a superfine rib knit. You can also knit
tubular using 516 needles.



New! New! New! from KNITKING

intarsia pattern charts AND CHARTING ACCESSORY



Made specifically for the JUMBO Knitter, these new Charts can also be transferred to your Knitleader and reproduced with the new INTARSIA FEEDER on the KH 840...

The CHARTING ACCESSORY fits the JUMBO Knitter... It is simple and efficient to use... The plastic row Ruler is held in place with Magnetic Buttons so that you always know exactly where you are.

There are three sets of Patterns with five to a set. Every Pattern is a Pullover but you can use the wonderful selection of Intarsia Designs on any garment... Skirts, Dresses, Coats, etc... Also included in our package deal is a packet of blank Charts so that you can draw your own patterns.

SPECIAL INTRODUCTORY PRICE
FOR EVERYTHING... \$49.95

Calif. residents add Sales Tax.
Shipping costs \$2.25

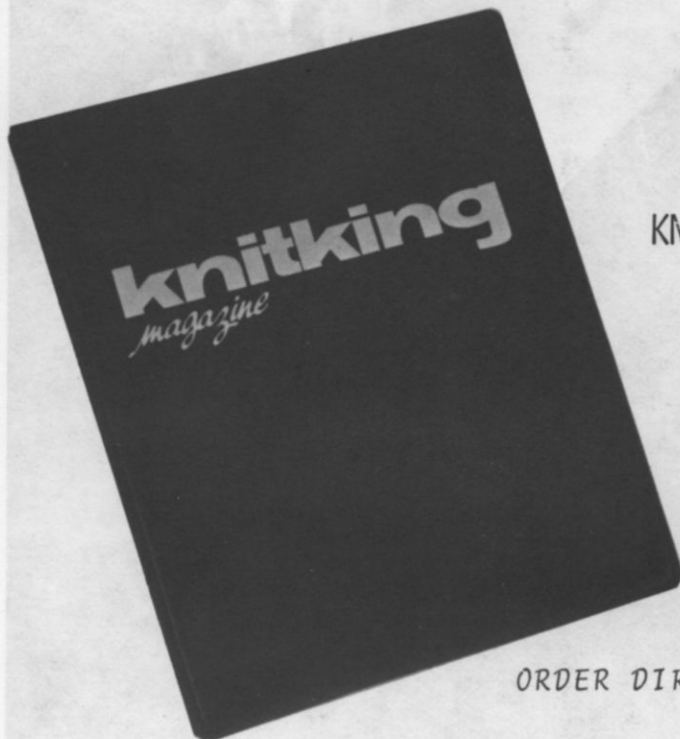

READY NOW ...

KNITKING MAGAZINE BOUND VOLUME NO. 14...

HARD BOARD COVER...
APPROXIMATELY 180 PATTERNS...
WITH COMPLETE INSTRUCTIONS...

PRICE... \$15.95
SHIPPING COSTS... 1.50

ORDER DIRECT FROM KNITKING - 1128 Crenshaw Blvd.
Los Angeles, Calif. 90019



DK 721

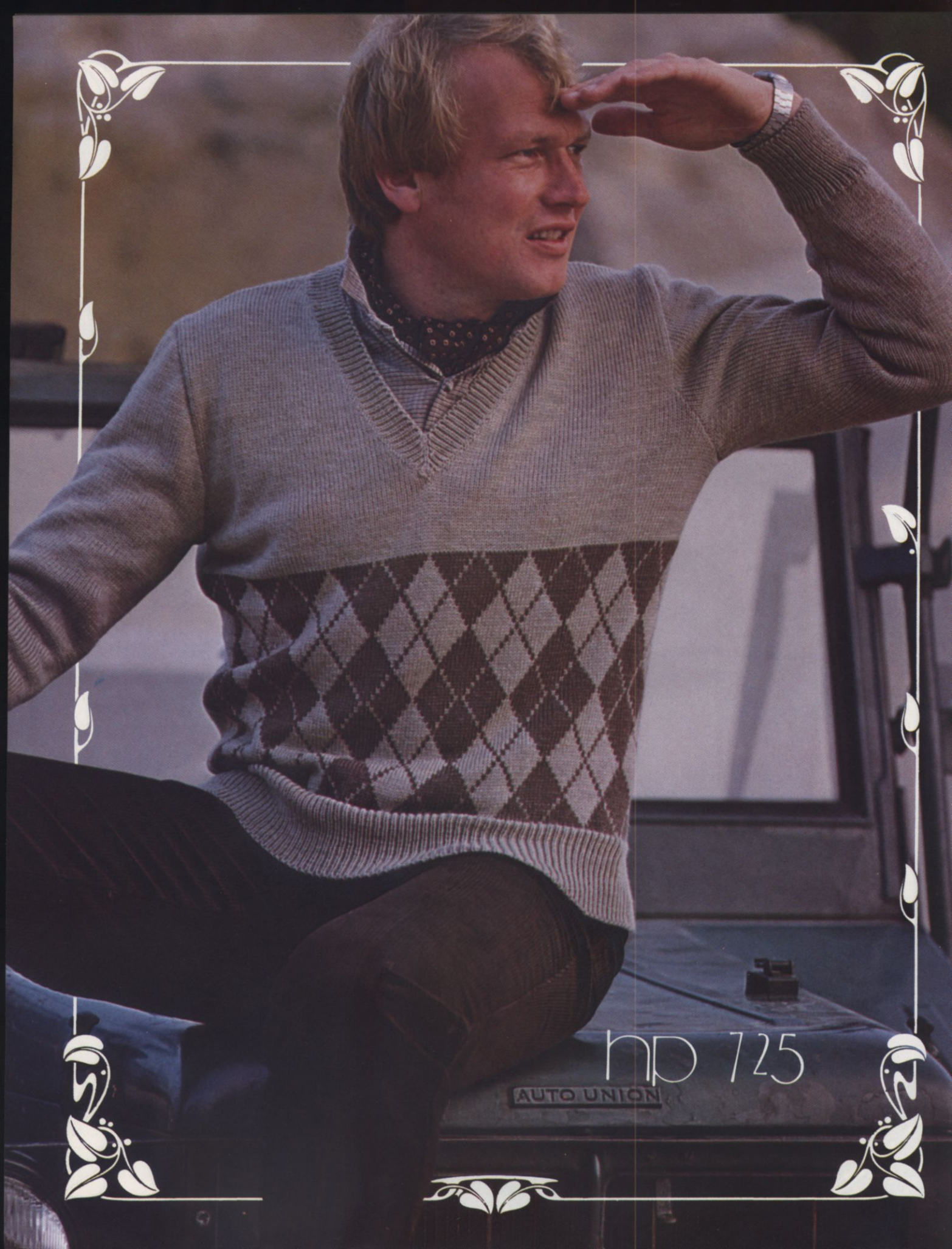

hp 725

AUTO UNION



dk 723



dk 726

dk 730



KK 736



KK 735

KK 738

KK 737



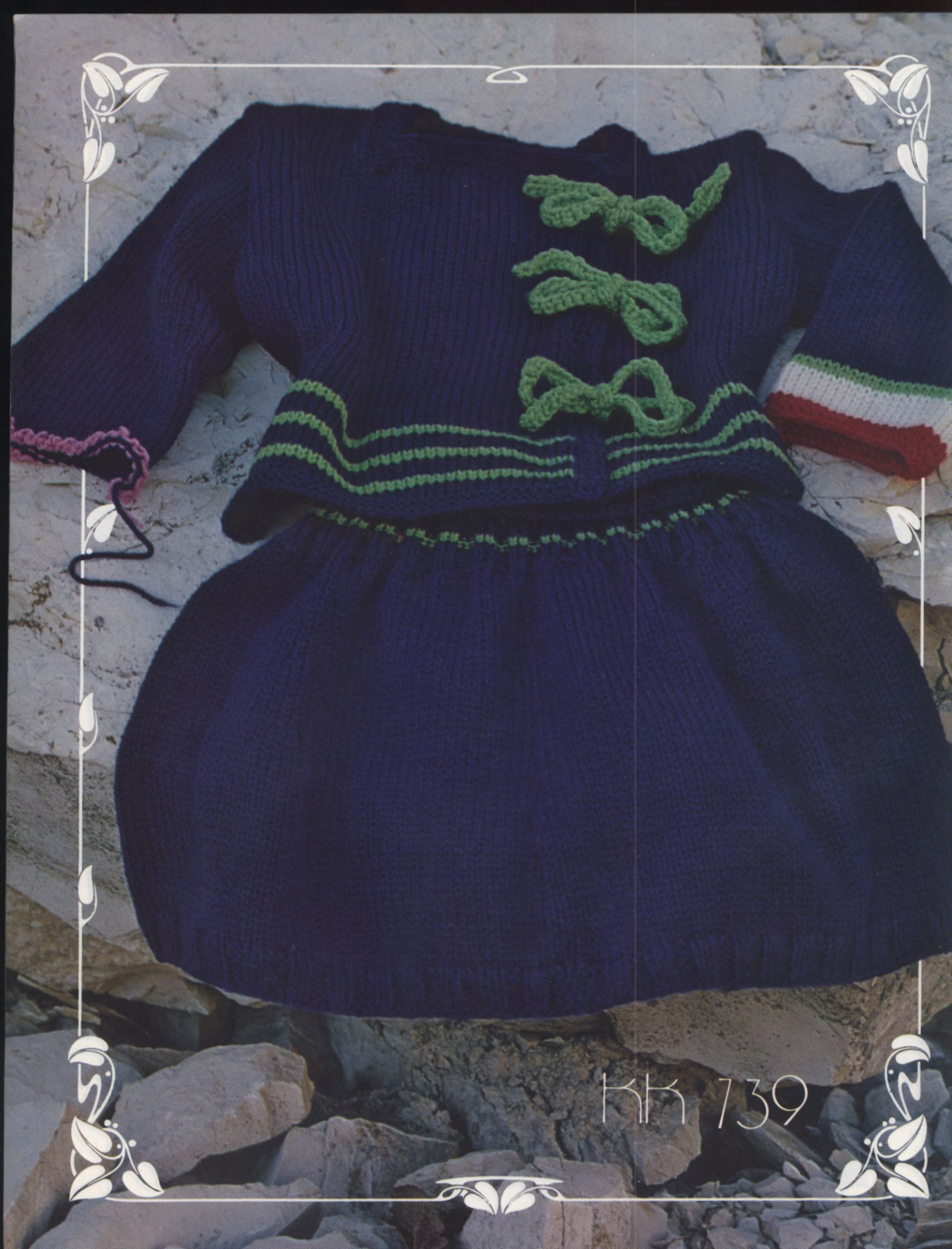

KK 739



KK 740

KK 741

hp 732

