

# knitking

*magazine*

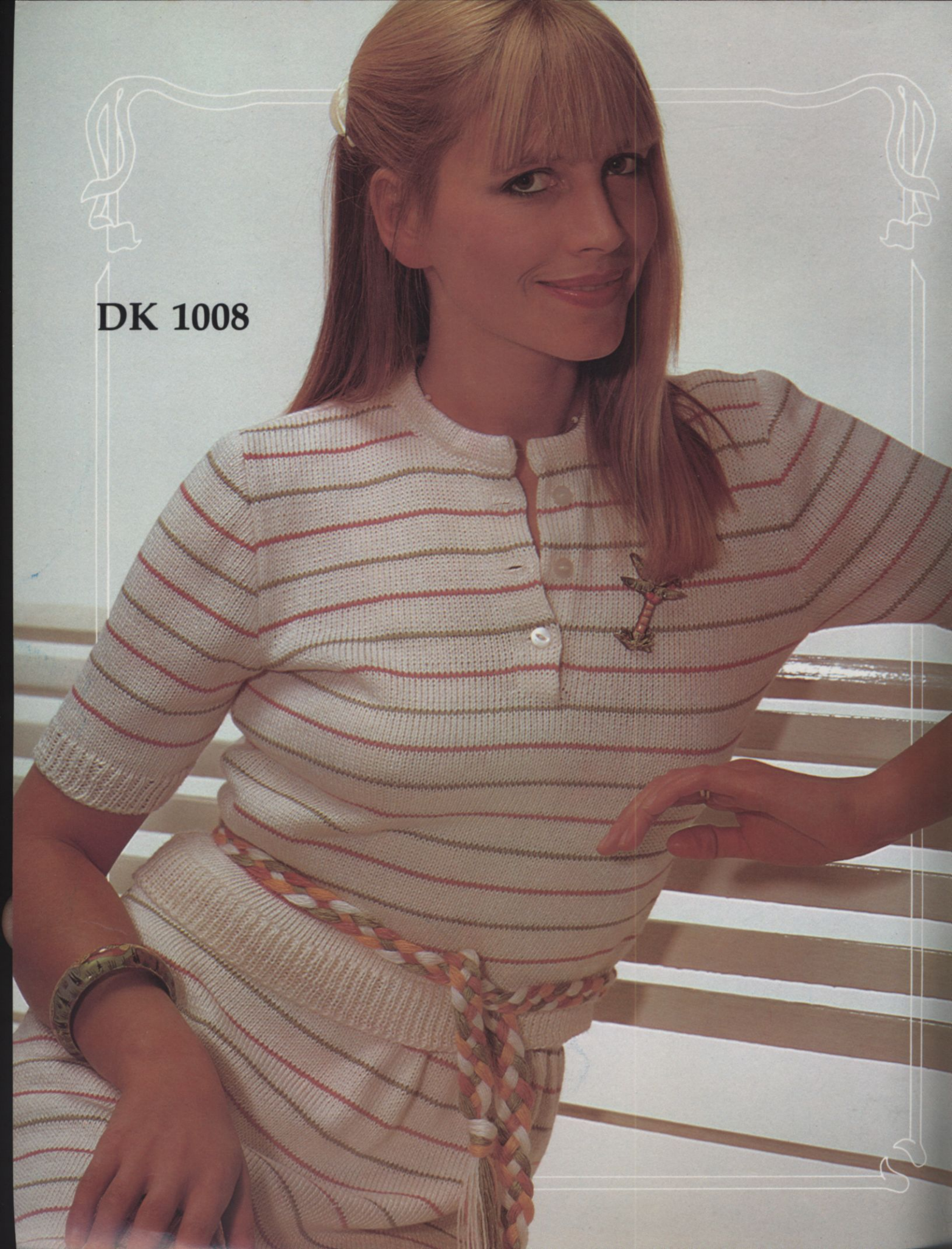



DK 1008

DK 1007



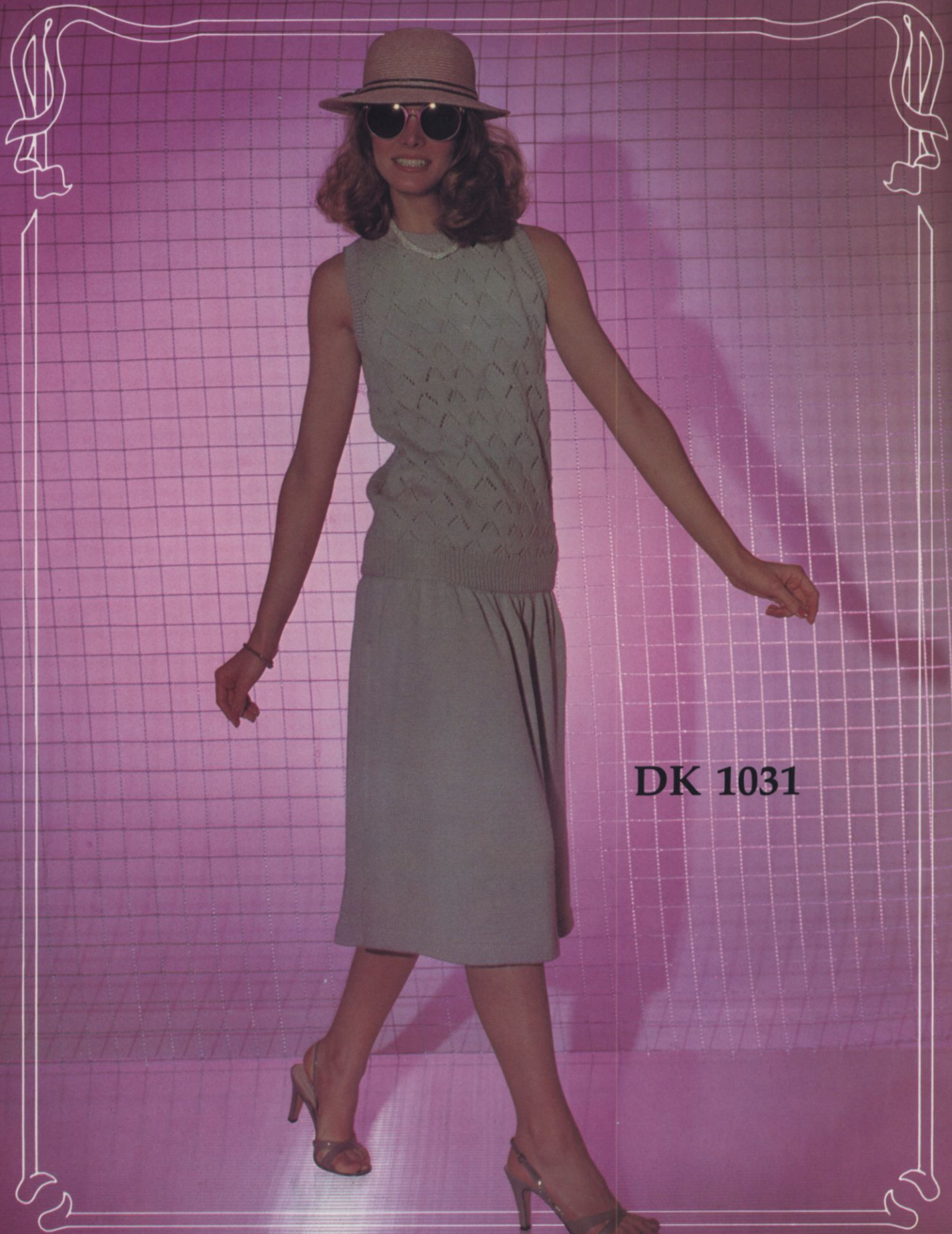

**DK 1031**



DK 1032

HP 1033



**DK 1014**



DK 1023

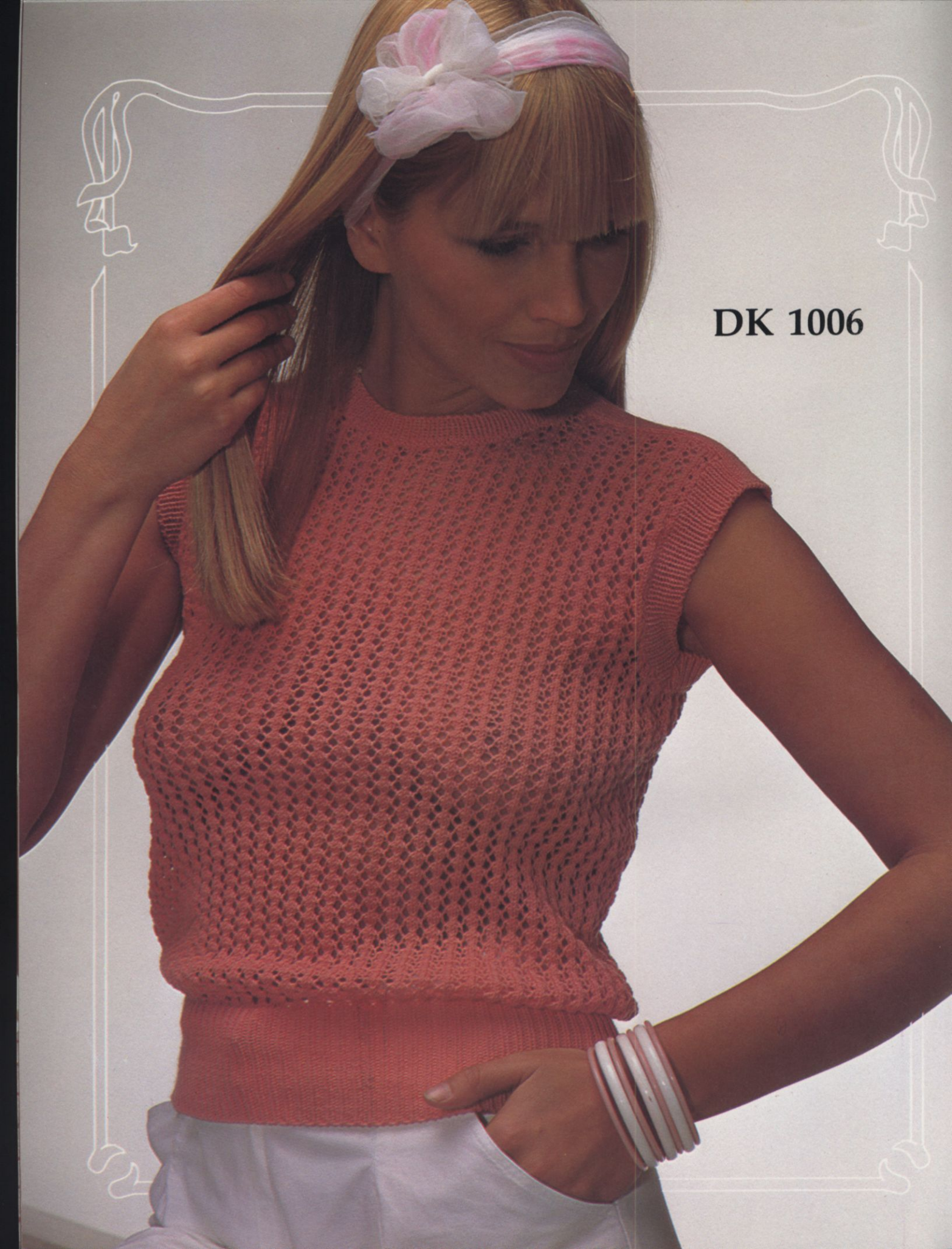

DK 1006



DK 1013



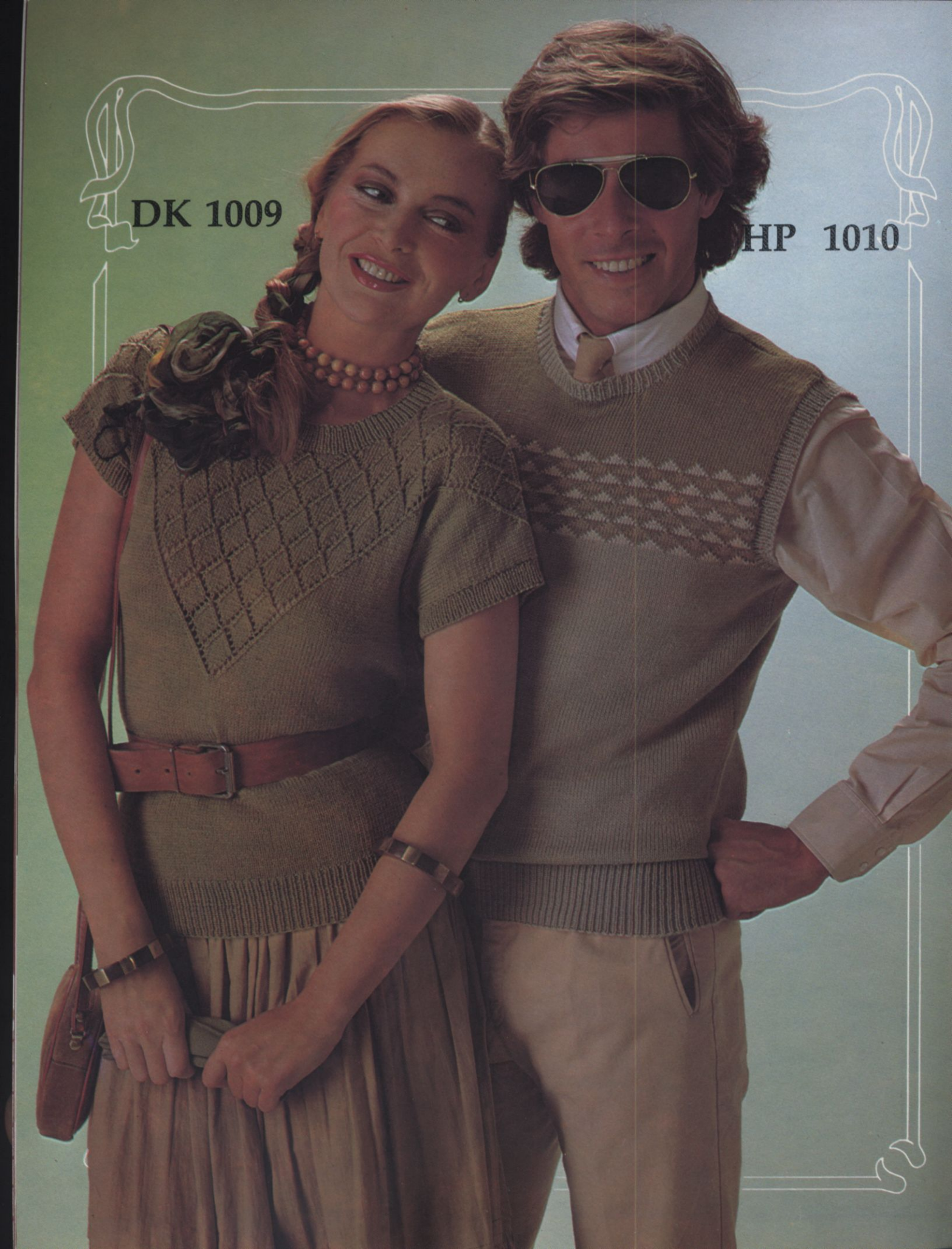

DK 1009

HP 1010

# knitking

magazine

Volume 17 No:1

INDEX PAGE NO.

DK 1006 - Woman's Pullover . . . . .	14
DK 1007 - Woman's Dress . . . . .	15
DK 1008 - Woman's 2 Piece Dress . . . . .	16
DK 1009 - Woman's Pullover . . . . .	17
HP 1010 - Man's Sleeveless Pullover . . . . .	18
DK 1011 - Woman's Sleeveless Pullover . . . . .	19
DK 1012 - Woman's Dress & Jacket . . . . .	20
DK 1013 - Woman's Pullover . . . . .	22
DL 1014 - Woman's Dress . . . . .	23
DK 1015 - Woman's Jacket . . . . .	24
KK 1016 - Girl's Jacket . . . . .	25
KK 1017 - Girl's Skirt & Blouse . . . . .	26
KK 1018 - Child's Blazer & Top . . . . .	27
KK 1019 - Girl's Pullover . . . . .	29
KK 1020 - Girl's Short Sleeved Sweater . . . . .	30
KK 1021 - Girl's Vest . . . . .	31
DK 1022 - Woman's 2 Piece Dress (Cover) . . . . .	
DK 1023 - Woman's Pullover . . . . .	33
DK 1024 - Woman's Tennis Shirt . . . . .	34
HP 1025 - Man's Zippered Jacket . . . . .	35
DK 1026 - Woman's Vest . . . . .	36
HP 1027 - Man's Pullover . . . . .	37
DK 1028 - Woman's Pullover . . . . .	38
DK 1029 - Woman's Pullover . . . . .	38
HP 1030 - Man's Jacket . . . . .	39
DK 1031 - Woman's Shell & Skirt . . . . .	40
DK 1032 - Woman's Jacket . . . . .	41
HP 1033 - Man's Pullover . . . . .	42

Publisher: KNITKING CORPORATION, 1128 Crenshaw Blvd., Los Angeles, Calif. 90019. Telephone: (213) 938-2079. Published bi-monthly. Subscriptions: USA — \$15.00 annually, single copies \$4.00; Canada — \$18.00; other parts of the world — \$20.00. The entire contents of KNITKING MAGAZINE are copyright and must not be reproduced in any shape or form without the express permission, in writing of the publisher. ©COPYRIGHT 1981 by KNITKING CORPORATION.

## Editorial

Another KNITKING Seminar has come and gone, and there is no doubt that this was the most interesting and educational ever... All of our Seminar Teachers had full knowledge of their subjects and the rare ability to pass that knowledge on in easy to understand fashion.

Yukiko Mitsumata, the charming and most knowledgeable expert from Brother Industries in Japan, demonstrated with fascinating skill and dexterity, the incomparable COMPUKNIT 910 and the all new KH 881 Punch Card Knitter with and without Ribbing Attachments and with Knitleaders and Color Changers.

Our hundreds of visitors consumed over 2,000 doughnuts and more than 45 gallons of coffee... We all had a wonderful educational fun filled week and we look forward to doing it again next year.

We believe that one of the reasons for more interesting Seminars are the fantastic strides made over the just few years in product design and improvement... So much versatility is built into the modern home knitting machine... Not planned obsolescence, just competition and a desire on the part of manufacturers (especially our suppliers) to produce the finest knitting machines possible.

There are so many design improvements in the new KNITKING KH 881 that machines 3 and 4 years old are obsolete in comparison... Just looking at previous models does not convey the great improvements built into the 881... Isolation of parts of Lace Punch Cards... Automatic retraction of end needles when knitting lace or other fancy stitch designs... Isolation of one, two, or three Motifs... Intarsia and Plating Feeders... Built in Knitleader that accepts both full and half size Charts and has a new easier operating technique...

When we first tested the KH 881, everything seemed to operate smoother and easier than any other Punch Card knitter we have ever tested... Our observations have since been echoed by a number of customers who traded older machines and other brands in for the KH 881... There is no doubt in our minds... the KNITKING KH 881 is the finest Punch Card Machine ever made.

















The State of the Art in knitting machines is obviously the COMPUKNIT KH 910 Electronic. It is in a class of its own... It does everything the Punch Card machines do and so much, much more... The major difference of course is the size of the Motif you can produce in your knitting... On a Punch Card machine you can knit a single motif 24 stitches wide... The Compuknit has no limitation... you can knit a single motif over the full 200 needles of the machine... It is also possible to make a single Lace Design covering the full width of the needle bed... and, most of all the Compuknit is so simple to program, a child can do it.

Who would have thought just a few short years ago that so much versatility could be built into one knitting machine... and considering the incredible amount of engineering skill and electronic wizardry plus 6 years of building and testing, the price we ask for a Compuknit KH 910 is very moderate.

It took a skilled operator 4 hours to test one Compuknit machine when production started... Since then the brains that built the Compuknit have built a computerized robot that checks out the full functions of the 910 Computer in a fraction of the time taken by a human being... Amazing...and you the machine knitter are the beneficiary of all this great technology... Automatic knitting machines are indeed a far cry from the basic stockinette machines of a few years ago.

# Pattern Symbols

## Knitting – Chart Symbols

- Size Symbols  
(2nd Size)
- < > 3rd Size
- ① Color Number
-  Cast on
-  Stitch
-  Row
-  Hem
-  Bind off
-  Stockinette stitch – worn on the Knit side.
-  Stockinette stitch – worn on the Purl side.
-  Knit 1, Purl 1 Ribbing
-  Ribbing Pattern – worn on the Knit side.
-  Ribbing Pattern – worn on the Purl side.
-  Closed Dart
-  Open Dart
-  Put on a stitch holder
-  Reverse 1 section
-  On every other needle
-  Number of Rows between Shapings. Make increase (or decrease) FIRST, then knit 4 rows. For example: 3 x 1  means decrease (or increase) 1 st., knit 4 rows; decrease 1 st., knit 4 rows; decrease 1 st., knit 4 rows; decrease 1 st., knit 4 rows. All decreasing (or increasing) without row numbers as shown must be shaped on every 2nd row.

 Increase

 Increase 2 sts. With a transfer tool, move the sts. over the left (or right) leaving 2 empty needles at the point of increase. At the increase point, move 1 st. to the left, (or right) so that there is an empty needles on each side of a stitch. On each side of the center stitch, pick up a stitch from the row below and hang it onto the empty needle.

 3 stitches on 1 needle. The 1st and 3rd stitch in a group of 3 has been hung on the 2nd or center needle.

 Short Row increase or decrease; for instance on a flared skirt knitted sideways.

 Pattern Stitch













 Pattern Stitch – worn on the Knit side.

 Pattern Stitch – worn on the Purl side.

 Repeat

- I = Front
- II = Back
- III = Sleeve
- IV = Skirt Front
- V = Skirt Back
- VI = Collar
- VII = Pocket
- VIII = Band
- IX = Belt
- X = Cuff
- XI = Pants Front
- XII = Pants Back

## Finishing – Chart Symbols

-  Match numbers on section for assembling.
-  Ease
-  Fold Line
-  Turn to the wrong side and hem.
- ### Stitch Symbols
-  Needles in holding position
-  Needles back into working position.
-  Empty needle (leave in working position)
-  Needle not used (in the out of work position).
-  Two stitches on 1 needle, either transferred from the right side or the left side, then put into holding position.
-  Needle holding 2 stitches. Stitch has been transferred from the RIGHT.
-  Needle holding 2 stitches. Stitch has been transferred from the LEFT.
-  Center of garment section



# General Instructions

## HOW TO READ THE CHARTS AND INSTRUCTIONS

There are 3 sizes given for each Pattern in KNITTING MAGAZINE. Above each Chart for the different sizes, you will see that the first and smaller sizes might be shown as 8/10, the second size as [12/14] and the third as [16/18]. Check the measurements at the bustline and hips on the Charts to be certain that you will knit the correct size, remembering these are ACTUAL measurements of the completed section and that there must be a bigger allowance at the bustline and hipline for a Jacket or a Coat than there would be for a fitted dress or a fitted blouse or pullover. The question in your mind should be "How do I want this garment to fit...?"

When you have chosen the size you need, you can follow the Charts as shown. You will notice that where the shapings are the same FOR ALL SIZES, only 1 set of shapings will be shown on the first Chart and if you are knitting the 2nd or 3rd size, you simply follow the shapings as given for the first size. If the shapings are different, this will be shown on the Charts and you should follow them as given.

On the Charts, increases and decreases will be shown as follows

5x1  
[6] The number in the box means number of ROWS between the shapings, while the 5x1 above the box means - 1 st. 5x... so you will increase or decrease 1 st. every 6th row 5x.

ARMHOLE SHAPINGS - NECK SHAPINGS - SHOULDER SHAPINGS - are made on every 2nd row UNLESS there is a number in a box along side or below the shapings. The rule is... where there is no box with a number, the shaping is made on every 2nd row.

## THE PRINTED INSTRUCTIONS

You can follow the printed instructions or use them in combination with the Charts. Where there is any question in the printed instructions, you have the Charts to show you how the section will look.

The 3 sizes, with the different amounts of cast on stitches and the different shapings will look like this...

Cast on 124 (136) [148] sts. You will  
Cast on 124 sts. for the first size.  
Cast on 136 sts. for the 2nd size.  
Cast on 148 sts. for the 3rd size.

The important thing to remember is that you MUST READ AHEAD so that you KNOW what to do for the size you are knitting. Sometimes where the number of stitches are the same but the number of times different, you will find shapings like this...  
3 sts. 1x (2x) [3x], 2 sts. 1x (2x) [3x], 1 st. 3x (4x) [5x].  
As you see, you MUST read ahead in order to follow the instructions as given for YOUR SIZE. The rows will be different for the different sizes in some cases... Shoulder and Neck shapings usually are worked at the SAME TIME for the back section - so watch for the words AT THE SAME TIME.

## HOLDING STITCHES ON THE LEFT SIDE WHILE SHAPING THE RIGHT SIDE

When knitting a section of garment in stockinette stitch, it is easy to hold the stitches on the left side while knitting the right half, but when knitting a Pattern Stitch such as a Norwegian Design, a Holding Position Design, Weaving, etc., you should use the following method. For the NECK SHAPING, we tell you to bind off the center sts.; put the needles on the left into holding position and complete the right half first... so with a strand of contrast yarn, knit ALL of the left side stitches manually by hand, pulling each stitch back against the needle bed to the OUT OF WORK position. When the right side is completed, carefully pull the stitches held on contrast, forward into working position and as you do so, undo the contrast yarn, line up the needles (KNITTING AM 3 machine owners, put the stitches under the sinkers) and complete the left half.

If you own a Japanese machine, you may find that when knitting the right half with the left side held in this way, the sinker plate will mark the left side while you are knitting the right half. To prevent this marking, you can tape a piece of paper over the knitting, underneath the sinkers, or if you own a Reversing Bar, you can hang this onto the Sinkers while you are knitting the right half. When hanging the Reversing Bar, be sure the eyes of the bar go BETWEEN the Sinker Posts on the upper part of the bar so that the tips of the bar only - show above the needle bed.

## FULL FASHION DECREASING OR INCREASING

For Stockinette stitch, always use the Full Fashion method for increasing or decreasing.

TO DECREASE: Hang the 3rd stitch onto the 2nd stitch then move the stitches in to fill the empty needle.

TO INCREASE: Move the 2 end stitches 1 needle outward, then pick up the 3rd stitch from the row below and hang it onto the empty needle.

FINISHING: Block all sections. For PULLOVERS, JACKETS, and DRESSES: Join front to back at sides and shoulders. Sew sleeves together and set in. Hem lower edge and sleeve edges if needed. For a double neckband or armhole band, sew 1 edge to the inside and 1 to the outside of neck or armhole. For a single ribbed band, sew 1 edge to the outside of neck or armhole edge. For a cardigan or jacket with buttonholes, finish buttonholes and sew on buttons.

PANTS: Join front to back at sides. Sew inside leg seams, then join center front and back. Make hem at waistline and insert elastic. Hem lower edge of pants legs.

## THE SAMPLE SWATCH

Before you begin to knit any garment, you will need to knit a sample piece using the yarn you have chosen for your garment, so that you can check the stitch and row gauge which must measure the correct number of stitches and rows in 5 cm (2 inches).

For each Pattern in KNITTING MAGAZINE, we give you 3 tension numbers to work from and if you use the specified yarn for the garment, you should be able to get the correct stitch and row gauge using one of these numbers. Here is a very easy way to make your sample swatch and count the stitches and rows without actually counting, by using our KNITTING CONVERTA TAPE.

Supposing the Tension Numbers for the Stitch and Row Gauge are given as 5 to 7. Set the Tension Dial to the first number which is 5. With contrast waste yarn, and using the quick cast on method, cast on 60 stitches and knit 10 rows. Change to garment yarn and turn the Row Counter to 0. Knit 30 rows. Counting from each end, knit the 10th stitch on each side by hand with a small piece of contrast yarn. Leave the needles in working position and knit 30 rows (Row 60), then knit 4 rows with contrast waste yarn. Turn the Row Counter to 0 and the Tension Dial to 6 and with garment yarn, knit 30 rows. Mark the 10th stitch on each side as you did before, knit 30 rows, then 4 rows with contrast waste yarn. Turn the Row Counter to 0 and with Tension 7, repeat the above once more, ending with 10 rows of contrast waste yarn. Remove the work from the machine by passing the Slide across the needles without yarn (sometimes called 'dropping'). Pull and stretch the sample piece both lengthwise and diagonally from corner to corner, then lengthwise again. Do not count the stitches and rows immediately, but allow the sample to rest for several hours or even over night. This will allow the stitches and rows to return to their basic form.

When your sample has rested and you are ready to count the stitches and rows, the KNITTING CONVERTA TAPE will do the counting for you without any counting on your part. Use the Tape as follows:

Measure the stitches with the TAPE, BETWEEN the 40 stitches marked with contrast waste yarn. Push the SLIDE so that the LEFT EDGE lines up to this exact measurement. Now look down along side the SLIDE and find the number 40 on the TAPE. The number directly opposite on the SLIDE will be your Stitch Gauge to 5 cm (2"). To find the number of rows in 5 cm (2"), place the TAPE to measure over the 60 rows, push the SLIDE to this number with the left edge lined up, the look for the number 60 on the TAPE and directly opposite this will be the number of rows to 5 cm (2")

If you do not own a KNITTING CONVERTA TAPE, you must mark a 5 cm (2 inch) square in the center of the knitting, then count the number of stitches and rows within the square.

# DK 1006



## WOMAN'S PULLOVER

SIZES: 8/10 (12)  
 YARN: Amore  
 GRAMS: 200 250  
 TENSION: 7 or 8  
 GAUGE: 13 1/2 sts. 20 rows = 5 cm (2")

A Lace Pattern. Punch your own Card.  
 The bands are K1, P1 Ribbing.

FINISHING: See General Instructions.  
 Sew Armbands to armhole and shoulder  
 saddle section to back. The front  
 neckband is sewn to other side of  
 saddle section.

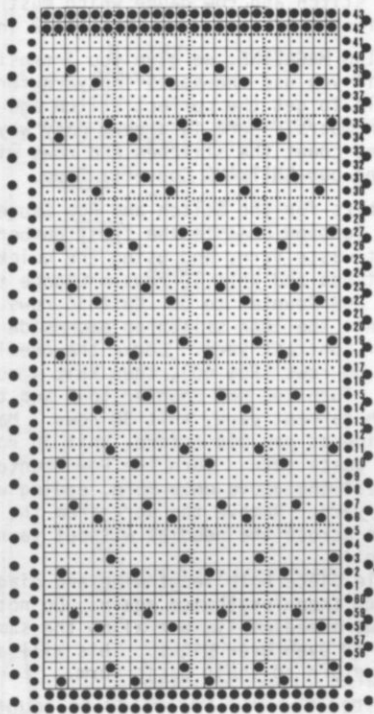

### FRONT: I

Work the front the same as the back to Row 188 (192).

Bind off the center 16 sts., put the needles on the left into holding position and complete the right side first.

\*ON NECK SIDE, bind off for both sizes.

3 sts. 2x, 2 sts. 3x, 1 st. 2x.  
 After Row 208 (216) bind off the remaining sts.

Bring the needles on the left into working position, knit 1 row in Pattern to the left side, turn the Row Counter back to 188 (192) and complete the left half. Follow the instructions from \*.

### FRONT NECK BAND:

Cast on 128 sts. and work 12 rows Ribbing. Remove onto contrast waste yarn.

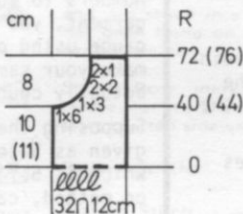

### ARMBANDS WITH SADDLE SHOULDER SECTION. Make 1, reverse 1.

Cast on 132 (136) sts. and work in Ribbing.  
 ON EACH SIDE increase 1 st. every 4th row 2x. After Row 12, leave the center 32 sts. on the machine and remove the sts. each side of these onto contrast waste yarn.  
 Put Counter at 0 and continue the Ribbing over the 32 sts. to Row 41 (45). SHAPE NECK: Bind off 6 sts. 1x, 3 sts. 1x, 2 sts. 2x, 1 st. 3x.  
 After Row 72 (76), remove the sts. onto waste yarn.  
 Make the 2nd band and saddle section with reverse shaping (ON THE RIGHT SIDE).

### BACK: II

Cast on 118 (124) sts. and work 36 rows Ribbing. Continue in Pattern.

Knit to Row 148 (152).

SHAPE ARMHOLE: ON EACH SIDE, bind off 3 sts. 1x, 2 sts. 2x, 1 st. 3x. (3 sts. 1x, 2 sts. 2x, 1 st. 3x).  
 Knit to Row 208 (216). Bind off.

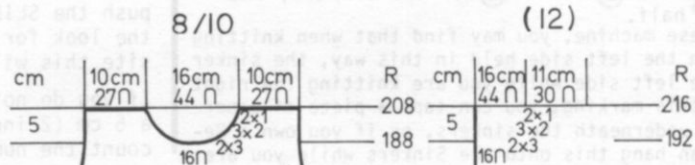
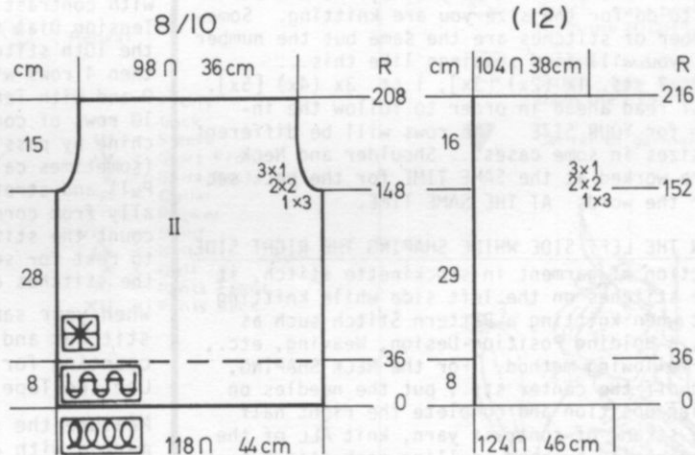



WOMAN'S PULLOVER

SIZES: 10/12 (14/16)  
 YARN: Amore  
 GRAMS: color 1 200 250  
 color 2 200 250  
 TENSION: 7 to 9  
 GAUGE: 12 sts. 17 rows = 5 cm (2")

Stockinette stitch with color stripes. Bands are K1, P1 Ribbing.

FINISHING: See General Instructions. With knit side facing you, hang 1 shoulder of back onto the machine and remove the waste yarn. Put these stitches behind the latches. Now hang matching shoulder of front with PURL side facing you and leave the sts. in the hooks of the needles. Knit the front shoulder sts through the back shoulder sts. and bind off. Repeat for other shoulder. Roll sleeves as shown in picture.

FRONT: I

Work the front the same as the back to Row 246 (252). Put half the sts. on the left into holding position and complete the right side first. \*SHAPE ARMHOLE same as the back AND AT THE SAME TIME, SHAPE NECK. ON NECK SIDE, decrease 1 st. every 3rd row 22x (24x). After Row 314 (324) remove the shoulder sts. onto contrast waste yarn.

NECKBAND:

Cast on 195 sts. with color 1 and work K1, P1 Ribbing. ON EACH SIDE increase 1 st. every 2nd row 4x. After Row 10, bind off or remove onto waste yarn.

BACK: II

Cast on 136 (144) sts. with color 1 and work Stockinette stitch with repeated stripes of 18 rows color 1, 18 rows color 2. ON EACH SIDE, decrease 1 st. every 25th row 10x for both sizes. After Row 246 (252), SHAPE ARMHOLE: ON EACH SIDE, bind off 4 sts. 1x, 3 sts. 1x, 2 sts. 1x, 1 st. 3x for both sizes. After Row 314 (324) remove each shoulder section and neck section onto contrast waste yarn separately. 24 (26) sts. for each shoulder and 44 (48) sts. for neck.

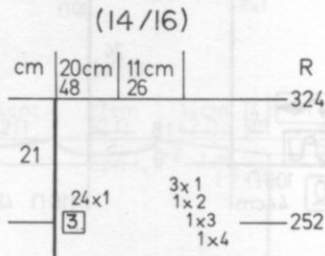
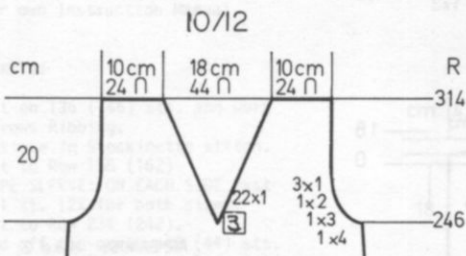
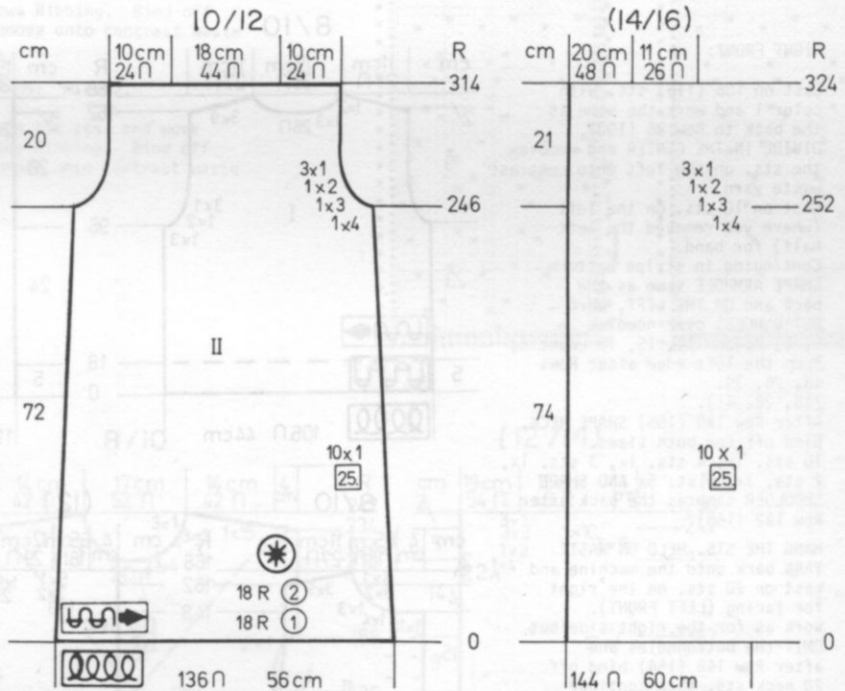

SLEEVES: III

Cast on 72 (76) sts. with color 1 and work the color stripes of 18 rows color 1, 18 rows color 2 same as the back and front BUT WORK THE FIRST 10 ROWS in K1, P1 Ribbing. After Row 10, ON EACH SIDE, increase 1 st. every 5th row 12x for both sizes. After Row 72 (76) SHAPE CAP: ON EACH SIDE, bind off 4 sts. 1x, 3 sts. 8x for both sizes. After Row 92 (98), bind off the remaining sts.

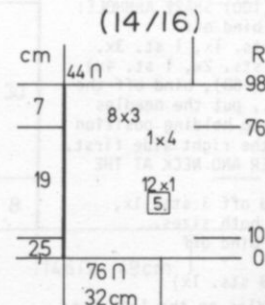
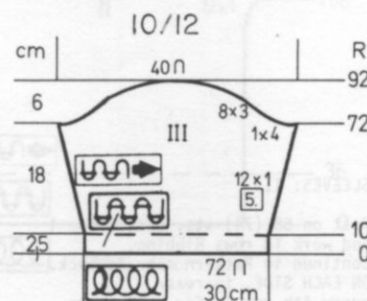

# DK 1008



## WOMAN'S 2-PIECE DRESS

SIZES: 8/10 (12)  
 YARN: Amore  
 GRAMS:  
 color 1 500 550  
 color 2 100 100  
 color 3 100 100  
 TENSION: 7 to 9  
 GAUGE: 12 sts. 17 rows = 5 cm (2")

Stockinette stitch with color stripes. The bands are K1, P1 Ribbing.

FINISHING: See General Instructions.

### NECKBAND:

Cast on 152 sts. with color 1 and work 12 rows Ribbing. Bind off or remove onto contrast waste yarn.

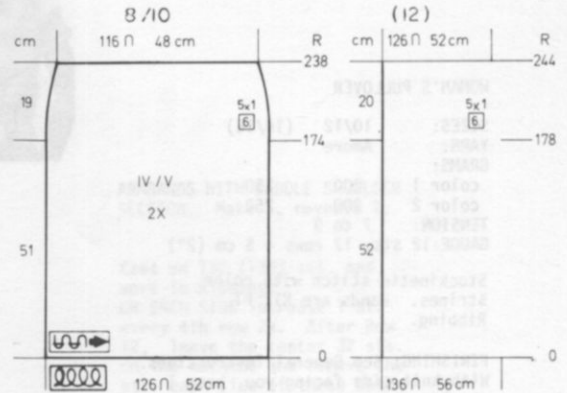

### RIGHT FRONT:

Cast on 106 (116) sts. with color 1 and work the same as the back to Row 96 (100). DIVIDE IN THE CENTER and remove the sts. on the left onto contrast waste yarn. Cast on 10 sts. on the left (where you removed the left half) for band. Continuing in stripe pattern SHAPE ARMHOLE same as the back and ON THE LEFT, work BUTTONHOLES over needles 5, 6, 7, and 14, 15, 16 counting from the left edge after Rows 13, 26, 39, (15, 28, 41). After Row 149 (155) SHAPE NECK. Bind off for both sizes. 10 sts. 1x, 4 sts. 1x, 3 sts. 1x, 2 sts. 3x, 1 st. 5x AND SHAPE SHOULDER same as the back after Row 162 (168).

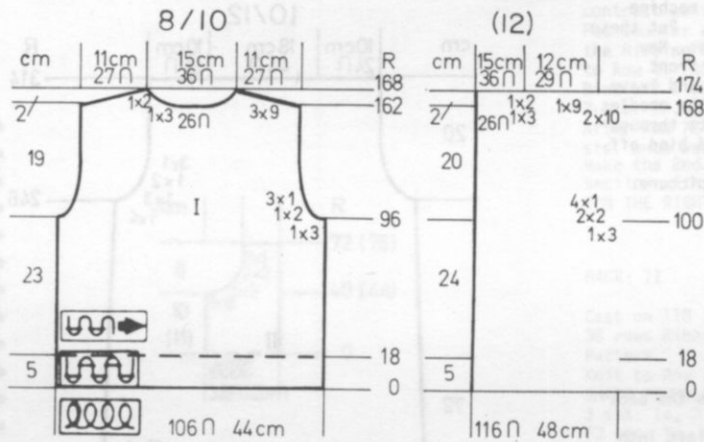

### SKIRT: Make 2 sections the same.

Cast on 126 (136) sts. with color 1 and work in Stripe Pattern. After Row 174 (178). ON EACH SIDE, decrease 1 st. every 6th row 5x for both sizes. After Row 238 (244). Bind off the remaining sts.

### SKIRT WAISTBAND: Make 2

Cast on 90 (94) sts. with color 1 and work 22 rows Stockinette stitch. Hang hem, then hang the skirt section onto band and bind off loosely.

HANG THE STS. HELD ON WASTE YARN back onto the machine and cast on 20 sts. on the right for facing (LEFT FRONT). Work as for the right side but OMIT the buttonholes and after Row 148 (154) bind off 20 neck sts. then continue the neck and shoulder shaping same as for right side.

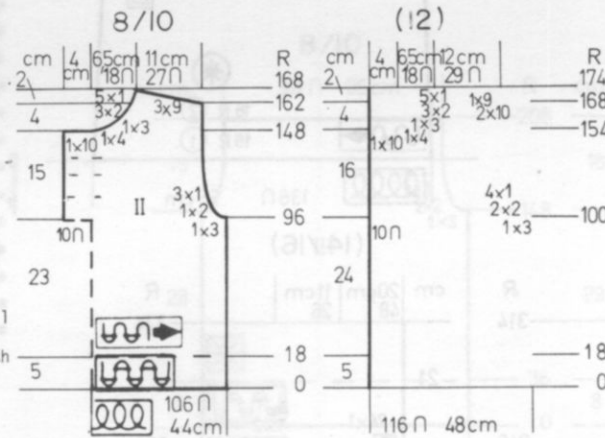

### BACK: I

Cast on 106 (116) sts. with color 1 and work 18 rows Ribbing. Continue in Stockinette stitch with color stripes of

- \*8 rows color 1
- 1 row color 2
- 8 rows color 1
- 1 row color 3

REPEAT FROM \* throughout.

After Row 96 (100) SHAPE ARMHOLE: ON EACH SIDE, bind off 3 sts. 1x, 2 sts. 1x, 1 st. 3x. (3 sts. 1x, 2 sts. 2x, 1 st. 4x). After Row 162 (168), bind off the center 26 sts., put the needles on the left into holding position and complete the right side first. \*SHAPE SHOULDER AND NECK AT THE SAME TIME.

FOR NECK, bind off 3 sts. 1x, 2 sts. 1x for both sizes.

FOR SHOULDER, bind off 9 sts. 3x. (10 sts. 2x, 9 sts. 1x)

Bring the needles on the left into working position, knit 1 row in pattern to the left side, turn the Row Counter back to 162 (168) and complete the left half. Follow the instructions from \*.

### SLEEVES: III

Cast on 68 (74) sts. with color 1 and work 10 rows Ribbing. Continue in Pattern same as back. ON EACH SIDE, increase 1 st. every 4th row 7x for both sizes. After Row 36 (40) SHAPE CAP. Please follow the bind offs on each size as shown on the Chart for your size.

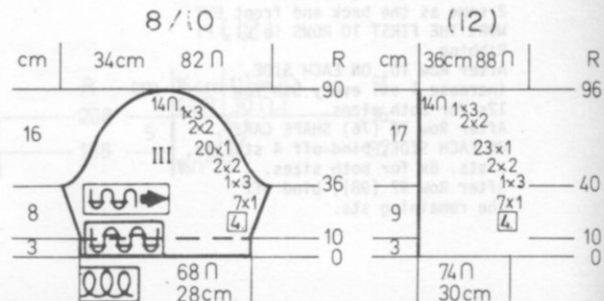

### ARBANDS: Make 2

Cast on 112 sts. with color 1 and work 12 rows Ribbing. Bind off or remove onto contrast waste yarn.





WOMAN'S PULLOVER

SIZES: 8/10 (12/14)  
 YARN: Vienna  
 GRAMS: 250 300  
 TENSION: 5 to 6  
 GAUGE: 15 sts, 21 rows = 5 cm (2")

Stockinette stitch with an Eyelet Design Yoke. Punch your own Card. Bands are K1, P1 Ribbing.

FINISHING: See General Instructions.

FRONT: I

Work the front the same as the back to Row 120. Put in Punch Card and begin Eyelet Design. Clip the two cards together and remember to PUSH ALL SELECTED NEEDLES BACK TO THE WORKING POSITION ON EACH SIDE OF THE 'V' (See Picture) Increasing the Pattern as shown. Make a sample piece first so you see what happens.  
 After Row 158 (162), SHAPE SLEEVE same as the back.  
 After Row 212 (220), bind off the center 20 (22) sts. (be sure to mark pattern row of Punch Card). put the needles on the left into holding position and complete the right side first. To put the left side sts. into holding position, Knit 1 row BY HAND USING A RAVEL CORD AND PULL EACH STITCH BACK TO 'A' position (out of work) and leave them there.  
 \*ON NECK SIDE, bind off 4 sts. 1x, 3 sts. 1x, 2 sts. 3x, 1 st. 3x for both sizes.  
 After Row 234 (242), SHAPE SHOULDER same as the back.  
 Carefully bring the sts. held on Ravel Cord back into working position being sure all the sts. are in the needle hooks. Row Counter 212 (220). Set Punch Card to the correct Row and work the left half. If you do not know how to set the Punch Card correctly be sure to read your own Instruction Manual.

NECKBAND:

Cast on 152 sts. and work 12 rows Ribbing. Bind off or remove onto contrast waste yarn.

ARMBANDS: Make 2.

Cast on 112 sts. and work 12 rows Ribbing. Bind off or remove onto contrast waste yarn.

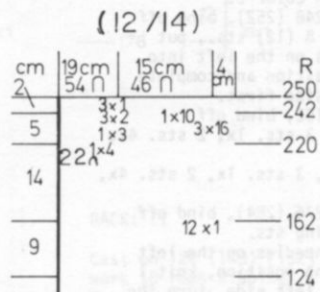
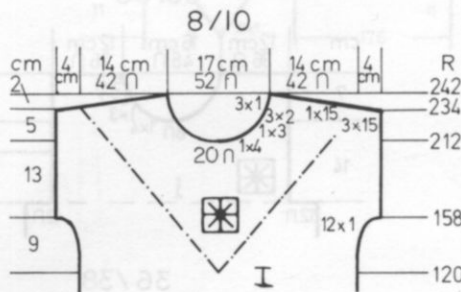
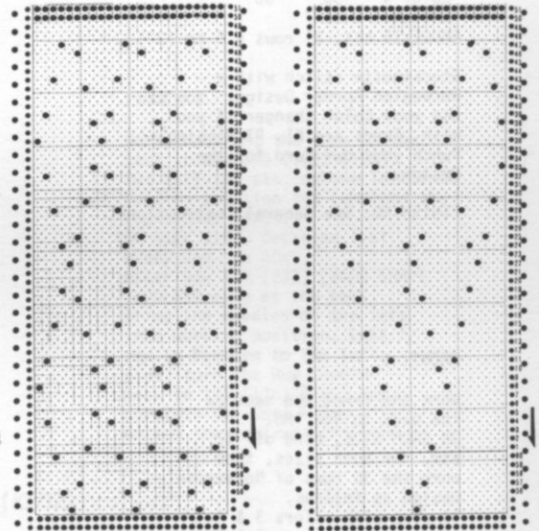

BACK: II

Cast on 136 (146) sts. and work 36 rows Ribbing. Continue in Stockinette stitch. Knit to Row 158 (162) SHAPE SLEEVE: ON EACH SIDE cast on 1 st. 12x for both sizes. Knit to Row 234 (242). Bind off the center 42 (44) sts. put the needles on the left into holding position and complete the right side first.  
 \*SHAPE SHOULDER AND NECK AT THE SAME TIME.  
 FOR SHOULDER, bind off 13 sts. 3x, 15 sts. 1x. (16 sts. 3x, 10 sts. 1x).  
 FOR NECK, bind off 3 sts. 1x, 2 sts. 1x for both sizes. Bring the needles on the left into working position, knit 1 row to the left side, turn the Row Counter back to 234 (242) and complete the left half. Follow the instructions from \*.

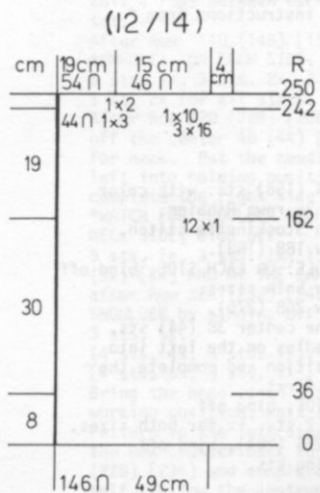
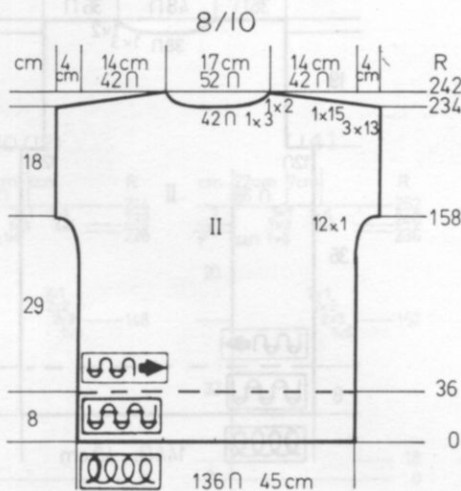

# HP 1010



## MAN'S PULLOVER

SIZES: 36/38 (40)  
YARN: Fortissima

GRAMS:  
color 1 200 250  
color 2 100 150  
color 3 50 50  
color 4 50 50

TENSION: 5 to 7  
GAUGE: 15 sts, 21 rows = 5 cm (2")

Stockinette stitch with a Norwegian Border Design. You can use your Color Changer if you wish. Bands are K1, P1 Ribbing. Punch your own Card for the Design.

FINISHING: See General Instructions.

### FRONT: I

Work the front the same as the back to Row 188.  
ON EACH SIDE, bind off 12 sts. for both sizes, then work the 36 rows of Norwegian Design as follows.

\*4 rows with colors 3 & 4.  
4 rows with colors 1 & 2.

REPEAT from \* to Row 224.  
Continue in Stockinette stitch with color 2.

After Row 248 (252), bind off the center 8 (12) sts., put the needles on the left into holding position and complete the right side first.

\*ON NECK SIDE, bind off

4 sts. 1x, 3 sts. 1x, 2 sts. 4x, 1 st. 5x.  
(4 sts. 1x, 3 sts. 1x, 2 sts. 4x, 1 st. 6x).

After Row 276 (284), bind off the remaining sts.

Bring the needles on the left into working position, knit 1 row to the left side, turn the Row Counter back to 248 (252) and complete the left half.  
Follow the instructions from \*.

### BACK: II

Cast on 144 (156) sts. with color 1 and work 36 rows Ribbing.  
Continue in Stockinette stitch.  
Knit to Row 188 (188).  
SHAPE ARMHOLE: ON EACH SIDE, bind off 12 sts. for both sizes.  
Knit to Row 268 (276).  
Bind off the center 38 (44) sts. put the needles on the left into holding position and complete the right side first.

\*ON NECK SIDE, bind off 3 sts. 1x, 2 sts. 1x for both sizes.

After Row 276 (284), bind off the remaining sts.

### NECKBAND:

Cast on 114 sts. with color 1 and work 8 rows Ribbing. Bind off or remove onto contrast waste yarn.

### ARMBANDS: Make 2.

Cast on 142 sts. with color 1 and work 8 rows Ribbing. Bind off or remove onto contrast waste yarn.

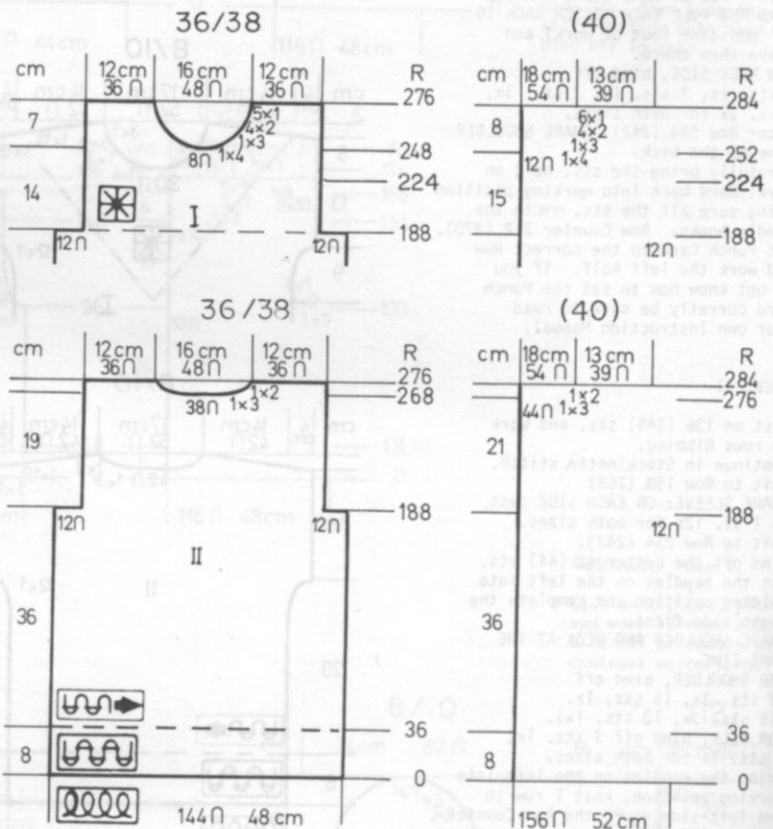
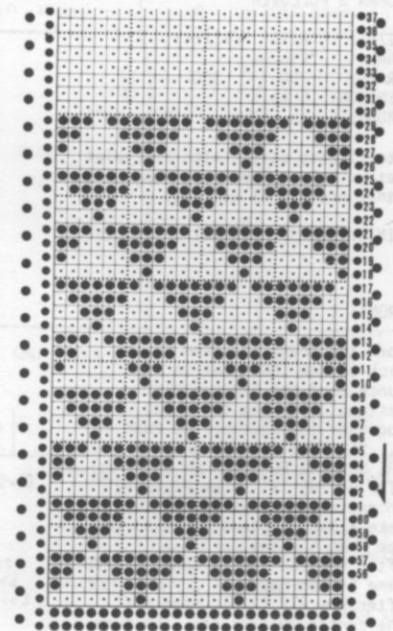

# DK 1011



## WOMAN'S SLEEVELESS PULLOVER

SIZES: 7/8 (10/12) [14]  
 YARN: Amore  
 GRAMS: 200 250 300  
 TENSION: 5 or 6  
 GAUGE: 15 sts, 21 rows = 5 cm (2")

A Lace Design. Punch your own Card. The bands are K1, P1 Ribbing.

FINISHING: See General Instructions.

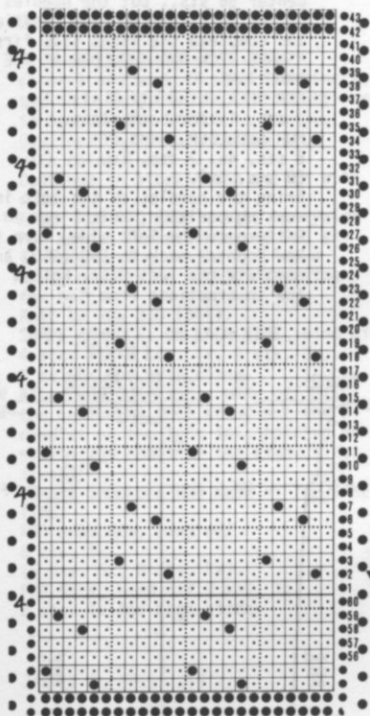

### NECKBAND:

Cast on 150 (162) [162] sts. and work K1, P1 Ribbing. ON EACH SIDE, decrease 1 st. every 2nd row 4x. After Row 8, bind off or remove onto contrast waste yarn.

### ARMBANDS: Make 2.

Cast on 110 (122) [122] sts. and work 8 rows Ribbing. Bind off or remove onto contrast waste yarn.

### FRONT: I

Work the front the same as the back to Row 176 (178) [186]. Put half the sts. on the left into holding position and complete the right side first.  
 \*ON NECK SIDE, decrease 1 st. every 2nd row 30x.  
 After Row 224 (232) [240] SHAPE SHOULDER same as the back. Bring the needles on the left into working position, knit 1 row in Pattern to the left side, turn the Row Counter back to 176 (178) [186] and complete the left half. Follow the instructions from \*.

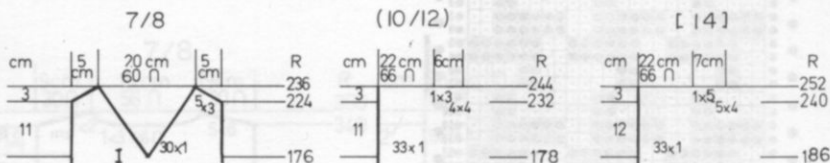

### BACK: II

Cast on 126 (140) [152] sts. and work 18 rows Ribbing. Continue in Lace Design. Be sure to mark Card as shown and always knit 4 rows between each pattern set.  
 After Row 140 (148) [152] SHAPE ARMHOLE: ON EACH SIDE, bind off 6 sts. 1x, 3 sts. 2x, 2 sts. 2x, 1 st. 2x for all sizes.  
 After Row 220 (228) [236], bind off the center 40 (44) [44] sts. for neck. Put the needles on the left into holding position and complete the right side first.  
 \*WATCH FOR SHOULDER SHAPING. ON NECK SIDE, bind off 5 sts. 1x, 3 sts. 1x, 1 st. 2x (3x) [3x] AND AT THE SAME TIME after Row 224 (232) [240], SHAPE SHOULDER by binding off 3 sts. 5x.  
 (4 sts. 4x, 3 sts. 1x).  
 (4 sts. 5x, 5 sts. 1x).  
 Bring the needles on the left into working position, knit 1 row in Pattern to the left side, turn the Row Counter back to 220 (228) [236] and complete the left half. Follow the instructions from \*.

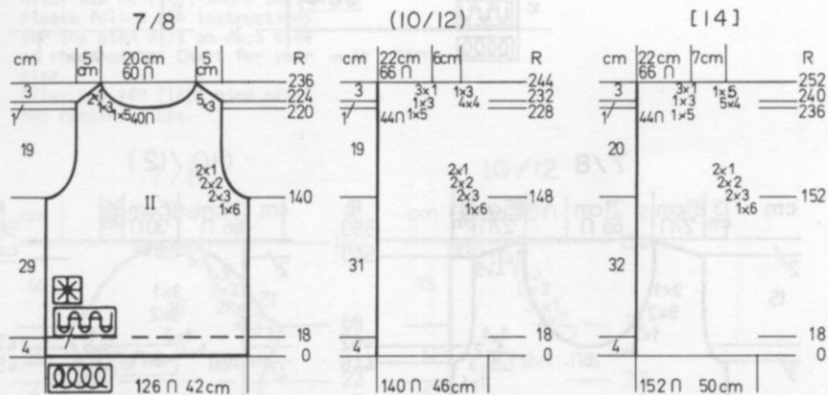

# DK 1012



## WOMAN'S DRESS & JACKET

**SIZES:** 7/8 (10/12)  
**YARN:** Amore  
**GRAMS:**  
 color 1 250 300  
 color 2 250 300  
 color 3 100 100  
**TENSION:** 4 to 6  
**GAUGE:** 16 sts. 26 rows = 5 cm (2")

Stockinette stitch with Fair Isle Designs. Punch 2 Cards as shown. Bands are K2, P2, Ribbing for Dress and Stockinette stitch for Jacket.

**FINISHING:** See General Instructions. Make a twisted Cord with color 3 using 8 strands for the belt.

### PATTERN I

REPEAT THE PUNCH CARD through Row 41, then punch 2 rows of holes for connecting Card.

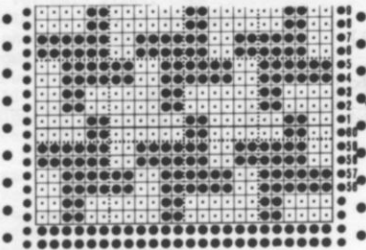

### PATTERN II

REPEAT THE PUNCH CARD through Row 41, then punch 2 rows of holes for connecting Card.

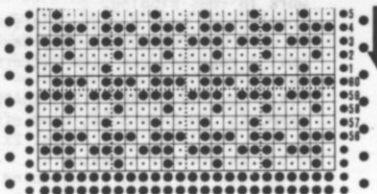

### DRESS FRONT: I

Work the front the same as the back to Row 446 (452). SHAPE ARMHOLE SAME AS THE BACK. After Row 462 (472), bind off the center 26 sts., put the needles on the left into holding position and complete the right side first. \*ON NECK SIDE, bind off 4 sts. 1x, 3 sts. 1x, 2 sts. 5x, 1 st. 3x for both sizes. After Row 540 (550) SHAPE SHOULDER same as the back. Bring the needles on the left into working position, knit 1 row to the left side, turn the row counter back to 462 (472) and complete the left half. Follow the instructions from \*.

### DRESS NECKBAND:

Sew up 1 shoulder then pick up 178 sts. and work in Ribbing of 4 rows color 2, 4 rows color 3, 4 rows color 2. Bind off.

### DRESS ARMBANDS: Make 2.

Cast on 110 (116) sts. and work in Ribbing with color stripes same as neckband. Bind off or remove onto contrast waste yarn.

### DRESS BACK: II

Cast on 172 (182) sts. with color 1 and work 52 rows Ribbing. Continue in Stockinette stitch with color 2 to Row 68. Work in Pattern II using color 1 and 2 to Row 102, then continue with Stockinette stitch using color 2. ON EACH SIDE decrease 1 st. every 22nd row 16x. After Row 446 (452), SHAPE ARM-HOLE: ON EACH SIDE bind off 4 sts. 1x, 3 sts. 1x, 2 sts. 1x, 1 st. 1x. (4 sts. 1x, 3 sts. 1x, 2 sts. 2x, 1 st. 1x. After Row 540 (550), bind off the center 56 sts., put the needles on the left into holding position and complete the right side first. \*SHAPE NECK AND SHOULDER AT THE SAME TIME. FOR NECK, bind off 3 sts. 1x, 2 sts. 1x for both sizes. FOR SHOULDER, bind off 5 sts. 4x, 7 sts. 1x. (6 sts. 5x). Bring the needles on the left into working position, knit 1 row in Pattern to the left side, turn the Row Counter back to 540 (550) and complete the left half. Follow the instructions from \*.

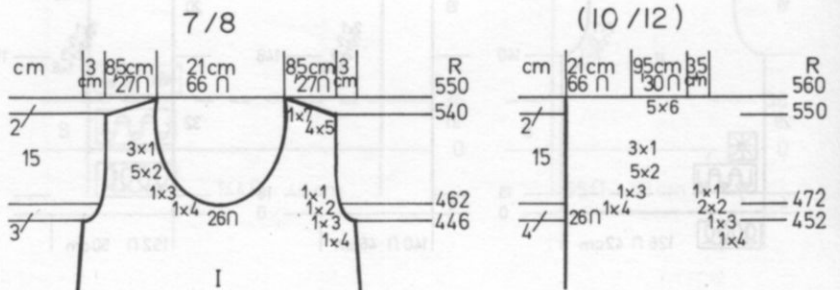
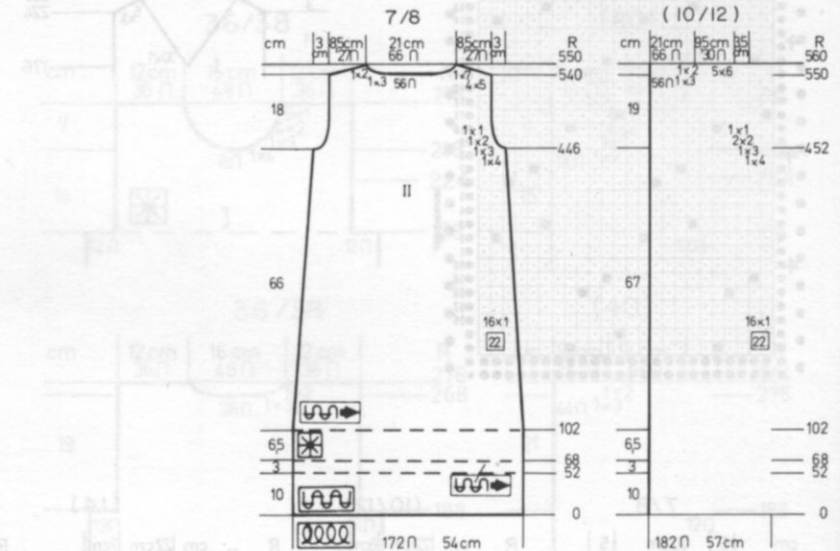

**JACKET FRONT: I** Make 1, reverse 1.

Cast on 71 (76) sts. with color 1 and work Stockinette stitch.  
 After Row 16, hang the hem then knit to Row 34.  
 Continue in Pattern to Row 110 same as you did for the back.  
 Continue in Stockinette stitch.  
 After Row 120 (120) make eyelets across same as back then continue to Row 238 (244).  
 SHAPE ARMHOLE same as the back and after Row 305 (315), SHAPE NECK: Bind off  
 5 sts. 1x, 4 sts. 1x, 3 sts. 1x, 2 sts. 4x (5x) 1 st. 5x (6x).  
 After Row 340 (350), SHAPE SHOULDER same as the back.

**JACKET BACK: I**

Cast on 148 (160) sts. with color 1 and work 16 rows Stockinette stitch. Hang the hem, then continue in Stockinette stitch to Row 34. Continue in Pattern to Row 110 with color 1 and 3.  
 Continue in Stockinette stitch with color 1.  
 After Row 120 (126), make an eyelet Row across (transfer every 2nd st. to neighboring needle and leave empty needles in work) for casing for belt.  
 Knit to Row 238 (244).  
 SHAPE ARMHOLE: ON EACH SIDE, bind off 4 sts. 1x, 3 sts. 1x, 2 sts. 3x, 1 st. 3x for both sizes.  
 After Row 340 (350), bind off the center 46 (54) sts., put the needles on the left into holding position and complete the right side first.  
 \*SHAPE SHOULDER AND NECK AT THE SAME TIME.  
 FOR SHOULDER, bind off 6 sts. 5x.  
 (6 sts. 5x, 8 sts. 1x).  
 FOR NECK, bind off 3 sts. 1x, 2 sts. 1x for both sizes.

**JACKET SLEEVES: III**

Cast on 90 (96) sts. with color 1 and work Stockinette stitch to Row 22 then hang the hem.  
 ON EACH SIDE, increase 1 st. every 4th row 12x for both sizes.  
 After Row 68 (74), SHAPE CAP: Please follow the instructions for the bind offs on each side as shown on the Chart for your size.  
 After Row 140 (150) bind off the remaining sts.

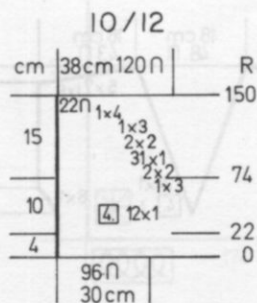
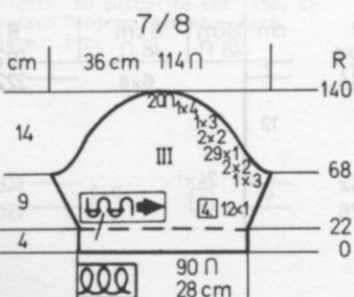
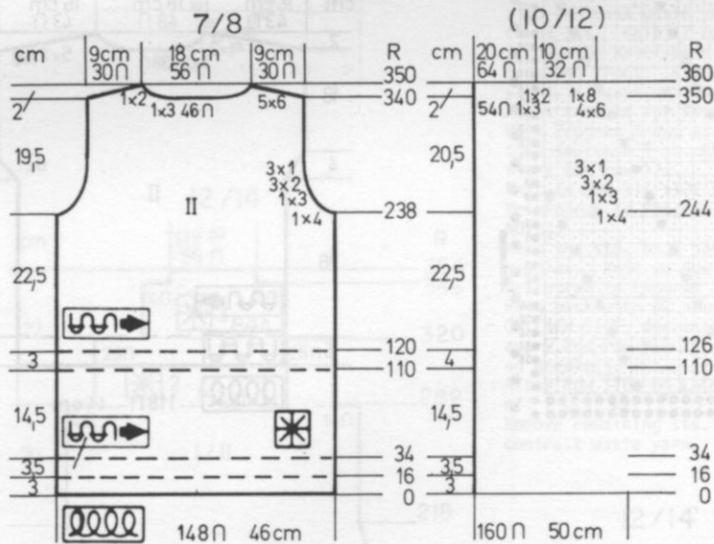
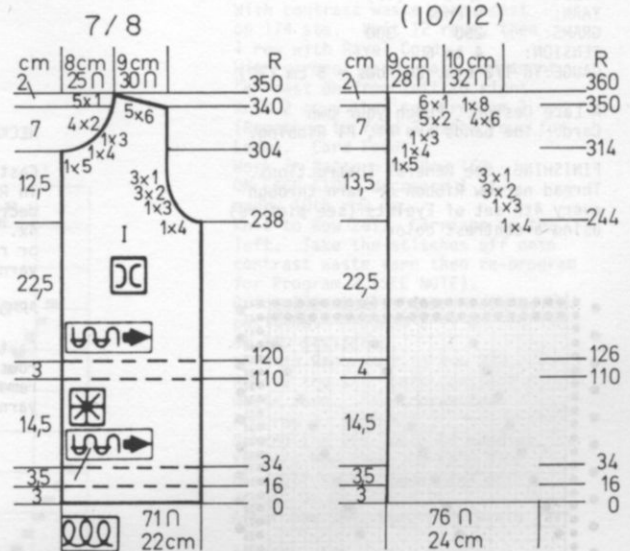

**JACKET FRONT BANDS: Make 2.**

Cast on 158 sts. with color 1 and work 25 rows Stockinette stitch. Bind off or you can remove onto waste yarn.  
 Sew 1 edge to inside and 1 to outside of front edges.

**JACKET NECKBAND:**

Cast on 144 sts. with color 1 and work 25 rows Stockinette stitch. Bind off or remove onto waste yarn. Sew 1 edge to inside and 1 to outside of neckline.



WOMAN'S PULLOVER

SIZES: 8/10 (12)  
 YARN: Vienna 300  
 GRAMS: 250 300  
 TENSION: 4 to 6  
 GAUGE: 16 1/2 sts. 20 rows = 5 cm (2")

A Lace Design. Punch your own Card. The bands are K1, P1 Ribbing.

FINISHING: See General Instructions. Thread narrow Ribbon or yarn through every 4th set of Eyelets (see picture) using a contrast color.

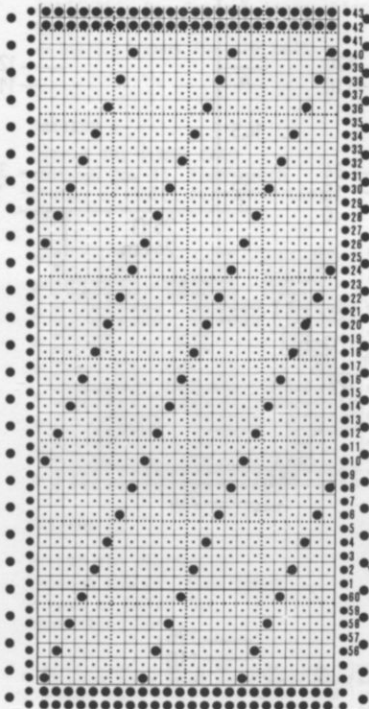

FRONT: I

Work the front the same as the back to Row 126 (130). Divide in the center. Put the needles on the left into holding position and complete the right side first.

\*ON ARM SIDE, increase 1 st. every 2nd row 8x same as for back and AT THE SAME TIME, ON NECK SIDE, decrease 1 st. every 4th row 24x.

After Row 214 (222) SHAPE SHOULDER same as the back. Bring the needles on the left into working position, knit 1 row in Pattern to the left side, turn the Row Counter back to 126 (130) and complete the left half. Follow the instructions from \*. WATCH PATTERN.

NECKBAND:

Cast on 198 sts. and work in Ribbing. ON EACH SIDE decrease 1 st. every 2nd row 4x. After Row 8, bind off or remove onto contrast waste yarn.

ARMBANDS: Make 2.

Cast on 98 sts. and work 8 rows Ribbing. Bind off or remove onto contrast waste yarn.

BACK: II

Cast on 118 (128) sts. and work 22 rows Ribbing. Continue in Lace Design. After Row 126 (130) ON EACH SIDE increase 1 st. every 2nd row 8x. Knit to Row 214 (222).

Bind off the center 38 sts., put the needles on the left into holding position and complete the right side first.

\*SHAPE SHOULDER AND NECK AT THE SAME TIME.

FOR SHOULDER, bind off 8 sts. 1x, 7 sts. 5x. (8 sts. 6x).

FOR NECK, bind off 3 sts. 1x, 2 sts. 1x for both sizes.

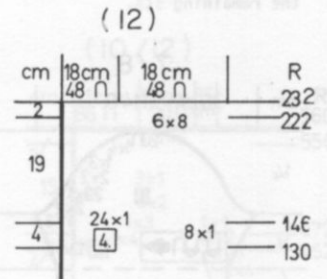
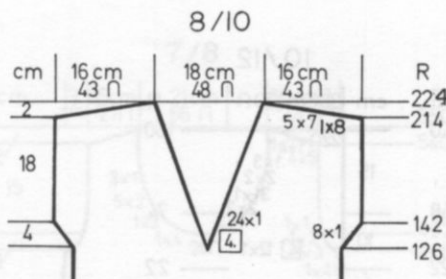
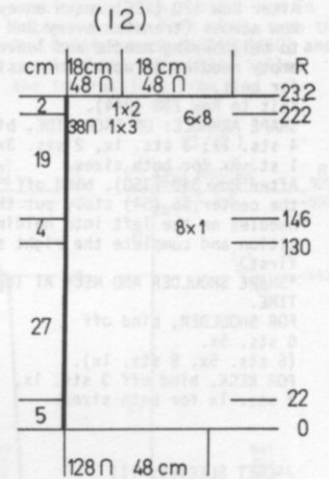
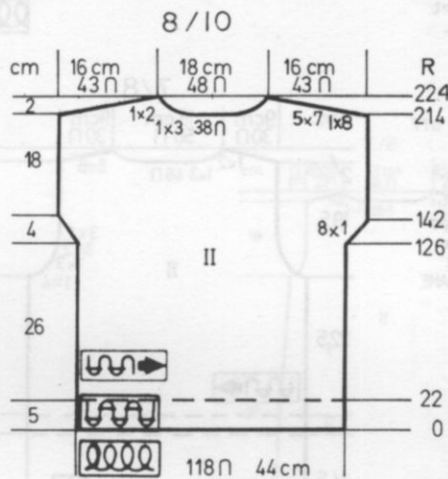



## WOMAN'S DRESS

SIZE: 12/14  
 YARN: Antille  
 AMOUNT: 1 Cone  
 TENSION: 4 to 6  
 GAUGE: 16 1/2 sts. 16 rows =  
 5 cm (2") in Pattern.

The Dress can only be made on the Electronic Machine because of the spacings between transfers for the Lace Design.

FINISHING: See General Instructions. Work single crochet around neckline, Sleeve and lower edge.

SPECIAL NOTE: There are 3 Lace Programs. The methods for transferring from 1 Program to the next is as follows:  
 Transfer from Program 1 to Program 2. At designated Row, take stitches off on waste yarn, remove from Knitter. Enter proper rows on Computer for Program 2, CF and move Lace Carriage from left to right to set out the needles for the first row. Remove Lace Carriage and replace it on the left rail (no yarn involved). The needles set out are the right needles of the 3 point needles. Hang the point stitches on their proper needles. The center of the garment is hung on Orange 2, Orange 1, and Green 1. Count 7 empty needles and hang the 2 hole stitches and the middle stitch on Orange 10, 11, 12 and Green 9, 10, 11, etc. across the needle bed. You will have 9 stitches to hang on 7 needles. Double up evenly on first and seventh needle.

When stitches are all hung, press RR to return to Set Line, CF to first row of program 2. Carriage on the left. Knit 1 row from left to right then use Lace Carriage to begin Program 2.

To Transfer Program 2 to Program 3. At designated Row, take off Program 2 onto waste yarn AFTER knitting 1 row. Yarn on the left side. Set Program 3 on Computer. On empty needles, Move Lace Carriage to set out needles for first Row of Program 3. Remove Lace Carriage and set it on the left rail. Needles set are again the right needle of the 3 point stitches. Hang point stitches across needle bed. There are 9 empty needles between point needles. Hang the center stitch of 010 on the 5th empty needle and double up all other stitches to fill remaining 8 needles. Pick up yarn on the left and knit 1 row to the right. RR Button to set line, CF to restart Program then move Lace Carriage...etc.

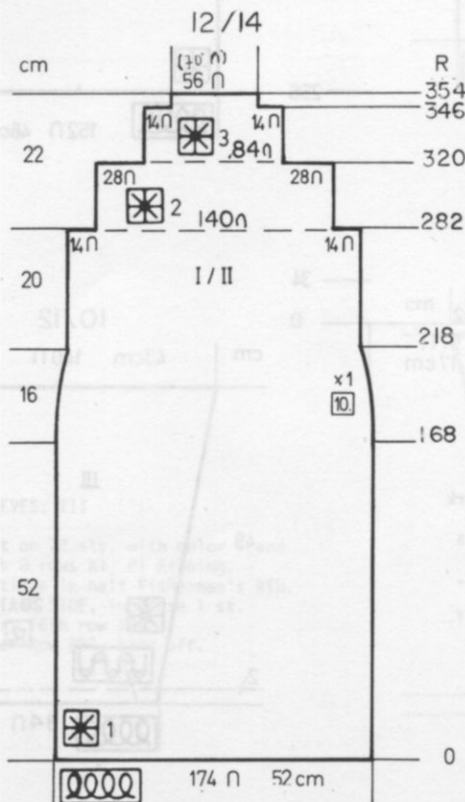
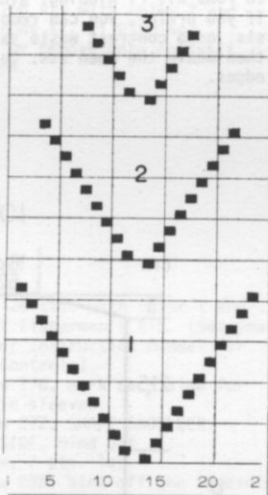

DRESS FRONT & BACK - 2 sections the same. I/II

With contrast waste yarn, cast on 174 sts. Knit 12 rows, then 1 row with Ravel Cord. With garment yarn, make permanent "e" cast on from left to right. Knit 2 rows then set Program 1. (Remember to feed 2 extra rows for Lace). Card Feed. Work in Pattern to Row 168. ON EACH SIDE, decrease 1 st. every 10th row 3x. Knit to Row 281. Carriage on the left. Take the stitches off onto contrast waste yarn then re-program for Program 2 (SEE NOTE). Bring 140 needles into working position. Program 2 is worked on 140 sts. Knit in Program 2 to Row 319. Remove the sts. onto contrast waste yarn. Re-program for Program 3. (SEE NOTE). Rehang the sts. onto 84 needles. Knit to Row 346. ON EACH SIDE bind off 8 sts. then bind off 2 sts. 3x ON EACH SIDE. After Row 354, remove on waste yarn.

SLEEVES: III Make 2.

With contrast waste yarn, cast on 88 sts. Knit 12 rows then 1 row with Ravel Cord same as the back and front. With garment yarn, "e" cast on from left to right same as for front and back. Work Program 1 and at the same time increase 1 st. ON EACH SIDE every 6th row 17x. Knit to Row 111 (122 sts.). Re-program to Program 2 (SEE NOTE). Hang the sts. back onto 102 needles. Knit to Row 149. Re-program to Program 3 (SEE NOTE). Hang back onto 62 needles. ON EACH SIDE, decrease 1 st. every 2nd row for 24 rows (38 sts. on needles). After Row 176, ON EACH SIDE, bind off 7 sts. 2x. Remove remaining sts. onto contrast waste yarn.

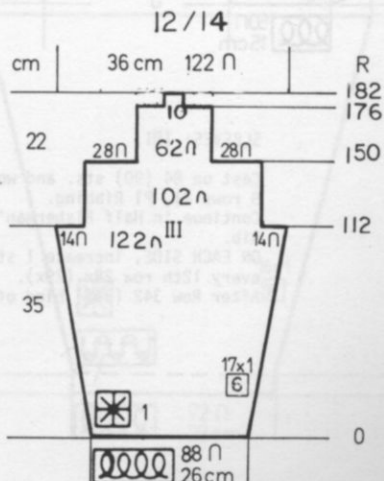

# DK 1015



## WOMAN'S JACKET

SIZES: 10/12 (14)  
 YARN: Vienna  
 GRAMS: 700 700  
 TENSION: 5 to 7  
 GAUGE: 16 1/2 sts. 34 rows = 5 cm (2")

Knitted on the Main Machine PLUS RIBBER. A half Fisherman's Rib with K1, P1 Ribbing around front, neck and lower edge.

FINISHING: See General Instructions.

FRONT: I Make 1, reverse 1.

Cast on 50 (57) sts. and work in Half Fisherman's Rib. ON THE LEFT (right for 2nd section), cast on 2 sts. 1x, 1 st. 16x, 2 sts. 1x. for both sizes.  
 After Row 250 (256) Mark side edge for setting in sleeves and ON FRONT EDGE decrease 1 st. every 8th row 20x for both sizes.  
 After Row 396 (408), SHAPE SHOULDER same as the back.

## BANDS:

BACK: 120 sts. Work 20 rows K1, P1 Ribbing. Bind off.  
 FRONT: Make 2. 200 sts. Work 20 rows K1, P1 Ribbing. Bind off.  
 If you prefer, you can remove sts. onto contrast waste yarn then weave the open sts. to edges.

## BACK: II

Cast on 152 (166) sts. and work Half Fisherman's Rib. (See your Ribber Instruction Manual for setting controls).  
 Mark Row 250 (256) ON EACH SIDE for setting in sleeves.  
 After Row 396 (408) SHAPE SHOULDER. ON EACH SIDE, bind off 5 sts. 10x.  
 (5 sts. 3x, 6 sts. 7x).  
 After Row 416 (428), bind off the remaining sts.

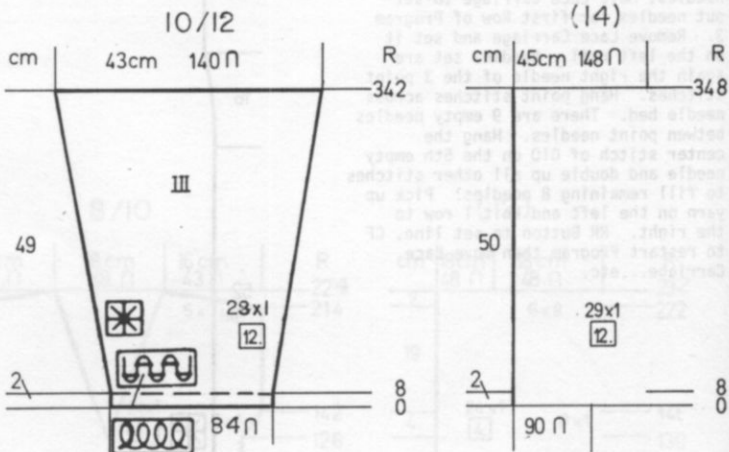
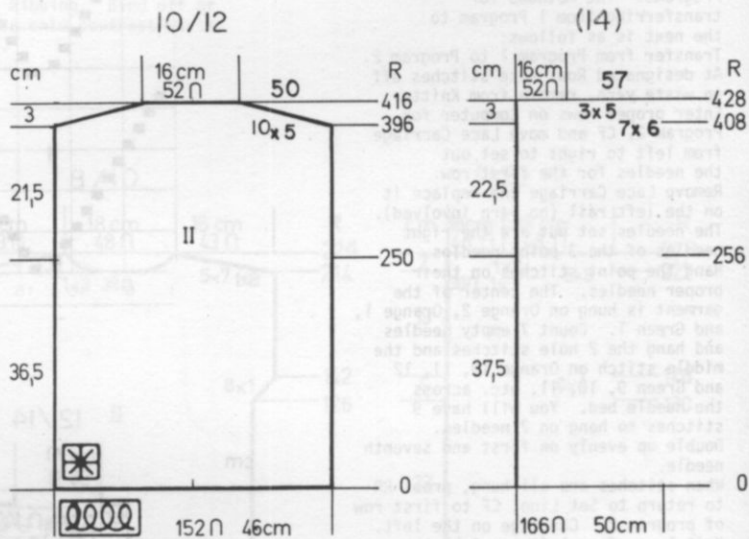
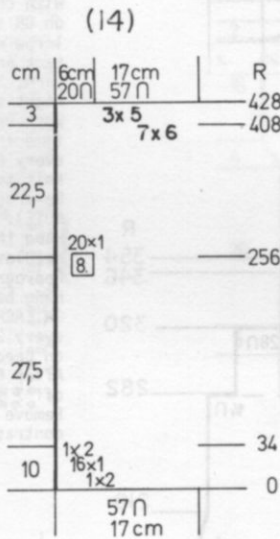
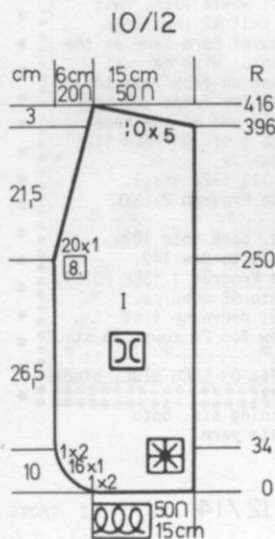

## SLEEVES: III

Cast on 84 (90) sts. and work 8 rows K1, P1 Ribbing. Continue in Half Fisherman's Rib. ON EACH SIDE, increase 1 st. every 12th row 28x (29x). After Row 342 (348) bind off.



# KK 1016

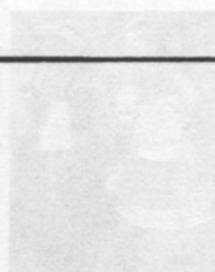

## GIRL'S JACKET

SIZE: 8/10  
 YARN: Vienna  
 GRAMS: color 1 300  
 color 2 100  
 TENSION: 5 to 7  
 GAUGE: 16/12 sts. 34 rows = 5 cm (2")

Knitted on the MAIN MACHINE PLUS RIBBER. Half Fisherman's Rib with K1, P. Ribbing for the bands.

FINISHING: See General Instructions

### FRONT: I

Cast on 42 sts. with color 1 and work in Half Fisherman's Rib. ON THE LEFT (right for 2nd section) increase 1 st. 16x. After Row 160, ON FRONT EDGE, decrease 1 st. every 8th row 16x and after Row 176, Mark side edge for setting in sleeves. After Row 272, SHAPE SHOULDER same as the back.

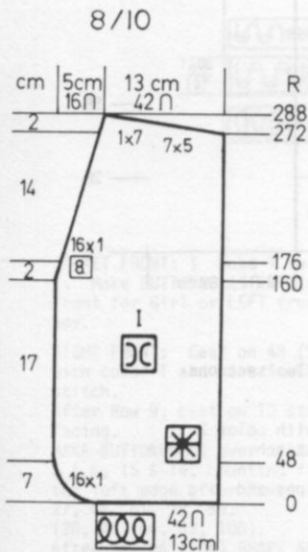

### BANDS:

BACK BAND: Cast on 126 sts. Color 2, and work 16 rows K1, P1 Ribbing. Bind off or remove onto waste yarn.

FRONT & NECK BANDS: Make 2. Cast on 168 sts. with color 2 and work 16 rows K1, P1 Ribbing. Bind off or remove onto contrast waste yarn.

### BACK: II

Cast on 126 sts. with color 1 and work Half Fisherman's Rib. (See your own Ribber Instruction Manual for setting Controls). After Row 176, mark each side for setting in sleeves. After Row 272, SHAPE SHOULDER. ON EACH SIDE, bind off 5 sts. 7x, 7 sts. 1x. After Row 288, bind off the remaining sts.

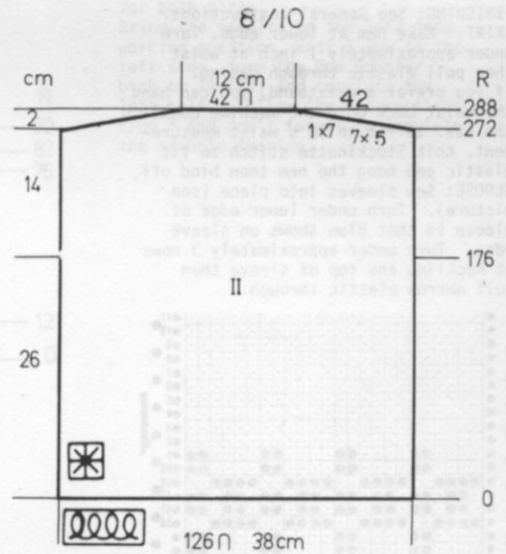

### SLEEVES: III

Cast on 72 sts. with color 1 and work 8 rows K1, P1 Ribbing. Continue in half Fisherman's Rib. ON EACH SIDE, increase 1 st. every 16th row 16x. After Row 280, bind off.

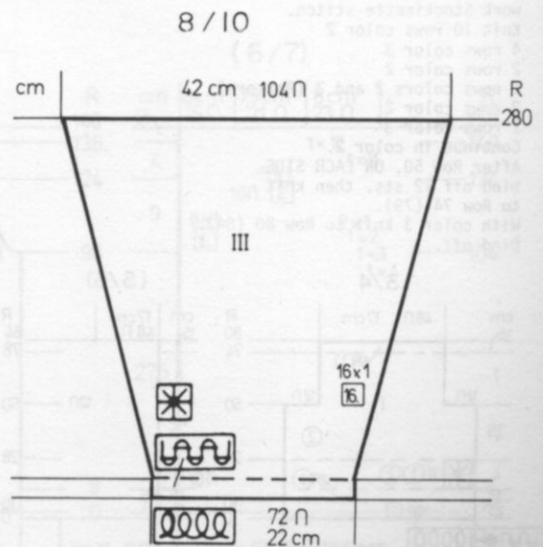

# KK 1017



## CHILD'S SKIRT & BLOUSE

**SIZES:** 3/4 (5/6)  
**YARN:** Amore  
**GRAMS:** For both Skirt & Blouse.  
 color 1 200 200  
 color 2 200 200  
 color 3 100 100  
**TENSION:** 7 to 9  
**GAUGE:** 14 sts. 17 rows = 5 cm (2")

Stockinette stitch with color stripes and Norwegian Border Design. Punch your own Card. If you wish to use your Color Changer, punch the Card in reverse.

**FINISHING:** See General Instructions.

**SKIRT:** Make hem at lower edge. Turn under approximately 1 inch at waist then pull elastic through casing. If you prefer a waistband, you can hang the waist back onto the machine doubling the sts. to fit child's waist measurement. Knit Stockinette stitch to fit elastic and hang the hem then bind off.  
**BLOUSE:** Sew sleeves into place (see picture). Turn under lower edge of sleeve so that blue shows on sleeve edge. Turn under approximately 3 rows at neckline and top of sleeve then pull narrow elastic through.

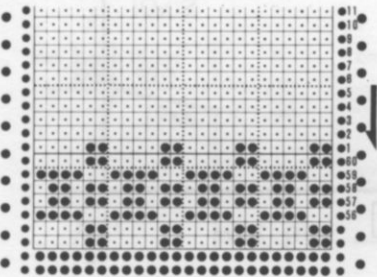

**SKIRT:** IV/V Two sections the same.

Cast on 150 (172) sts. with color 1 and work Stockinette stitch. Knit to Row 28.  
 Work the color stripes and Pattern as follows.  
 2 rows of color 3  
 4 rows color 2  
 2 rows color 1  
 2 rows color 2  
 8 rows colors 2 and 3 (Pattern)  
 2 rows color 2  
 2 rows color 1  
 4 rows color 2  
 2 rows color 3.  
 Continue in Stockinette stitch with color 1.  
 ON EACH SIDE, decrease 1 st. every 4th row 16x (20x).  
 After Row 124 (138), bind off.

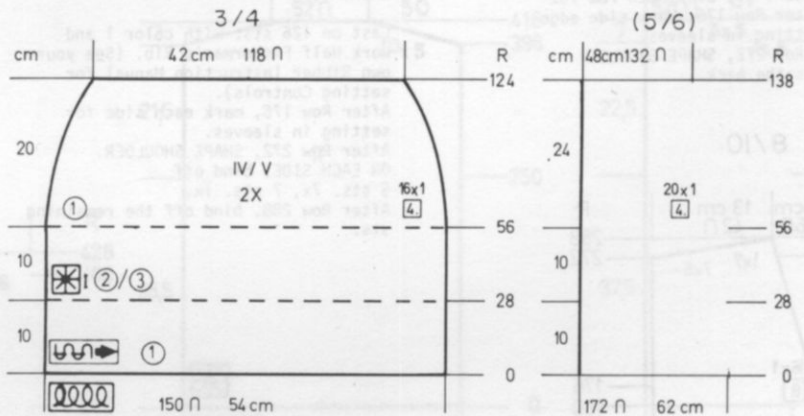

## SLEEVES: III

Cast on 72 sts. with color 2 and work Stockinette stitch.  
 Knit 10 rows color 2  
 4 rows color 3  
 2 rows color 2  
 8 rows colors 2 and 3 (Pattern)  
 2 rows color 2  
 2 rows color 3  
 Continue in color 2.  
 After Row 50, ON EACH SIDE, bind off 12 sts. then knit to Row 74 (78).  
 With color 3 knit to Row 80 (84).  
 Bind off.

**BLOUSE FRONT & BACK - Two sections the same. I/II**

Cast on 82 (92) sts. with color 2 and work Stockinette stitch. Knit to Row 86 (102).  
 Continue in Color Stripes and Pattern as follows.  
 2 rows color 3  
 2 rows color 2  
 8 rows colors 2 and 1 (Pattern)  
 2 rows color 2  
 6 rows color 3  
 After Row 106 (122) bind off.

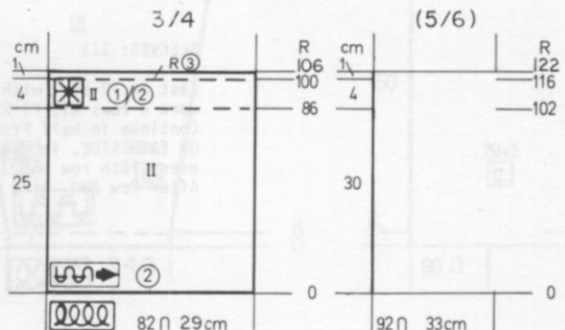
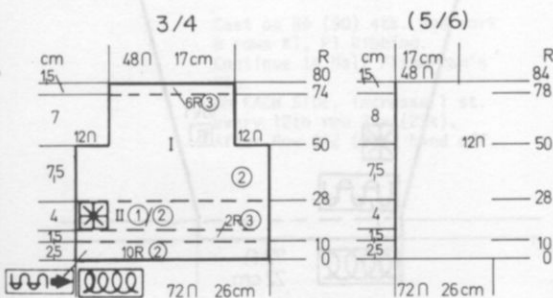

# KK 1018



## CHILD'S BLAZER & SUN TOP

SIZES: 4/5 (6/7)  
 YARN: Amore  
 GRAMS:  
 color 1 200 250  
 color 2 100 100  
 TENSION: 7 to 9  
 GAUGE: 14 sts. 17 rows = 5 cm (2")

Stockinette stitch with bands in  
 K1, P1 Ribbing.

FINISHING: See General Instructions.

SUN TOP FRONT & BACK I/II Both  
 sections the same.

Cast on 87 (95) sts. with color  
 1 and work 12 rows Ribbing.  
 Continue in Stockinette stitch with  
 color 2.  
 Knit to Row 68 (76).  
 SHAPE ARMHOLE: ON EACH SIDE, bind off.  
 6 sts. 1x, 2 sts. 2x, 1 st. 4x, BUT  
 WATCH FOR NECK SHAPING.  
 (8 sts. 1x, 2 sts. 3x, 1 st. 4x)  
 BUT WATCH FOR NECK SHAPING.  
 AT THE SAME TIME, after Row 74  
 (82) bind off the center 37 sts.  
 put the needles on the left into  
 holding position and complete the  
 right side first.  
 \*ON NECK SIDE, bind off  
 3 sts. 1x, 2 sts. 3x, 1 st. 2x  
 for both sizes.  
 Bring the needles on the left into  
 working position, knit 1 row to the  
 left side, turn the Row Counter  
 back to 74 (76) and complete the  
 left half. Follow the instructions  
 from \* and don't forget to complete  
 the armhole shaping.

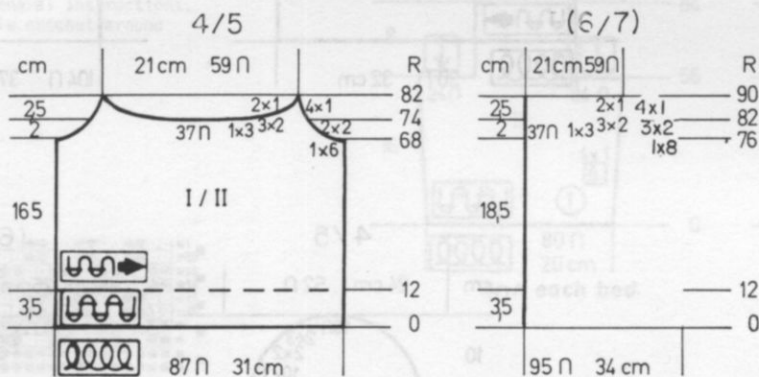

JACKET FRONT: I Make 1 reverse  
 1. Make BUTTONHOLES in RIGHT  
 front for Girl or LEFT front for  
 boy.

RIGHT FRONT: Cast on 48 (55) sts.  
 with color 1 and work Stockinette  
 stitch.

After Row 9, cast on 10 sts. for  
 facing.

MAKE BUTTONHOLES over needles  
 5 & 6, 15 & 16, counting from  
 the left edge after Rows  
 27, 44, 61, 78, 95.

(28, 46, 64, 82, 100).

After Row 96 (104) SHAPE ARMHOLE  
 same as the back BUT AT THE  
 SAME TIME, ON FRONT EDGE,  
 increase 1 st. every 6th row 6x,  
 AND AT THE SAME TIME, after  
 Row 124 (134), bind off the  
 8th to 25th sts. counting from  
 the left edge, put the needles  
 on the left into holding position  
 and complete the right side first.

ON NECK SIDE, bind off  
 3 sts. 2x, 2 sts. 2x, 1 st. 4x  
 and after Row 136 (146) SHAPE  
 SHOULDER same as the back.  
 Bring the needles on the left  
 into working position, knit 1  
 row to the left side, turn the  
 Row Counter back to 124 (134)  
 and ON NECK SIDE, bind off  
 2 sts. 1x, 1 st. 5x.  
 Reverse shaping for left front  
 and omit buttonholes.

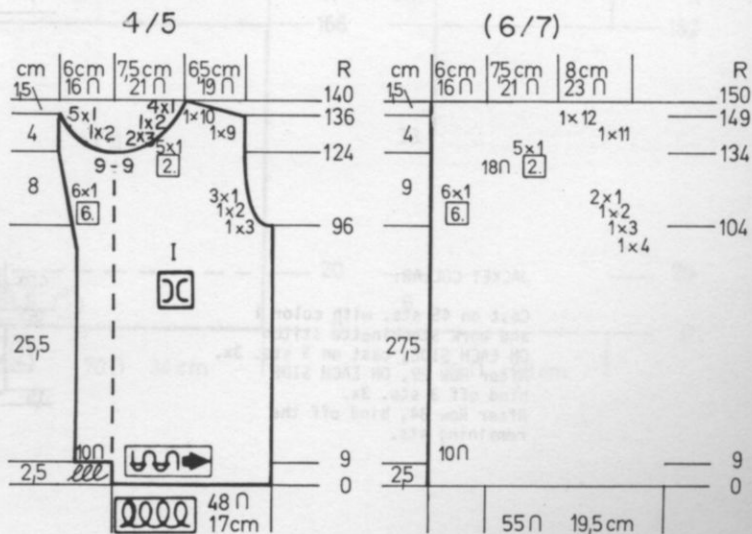

JACKET BACK: II

Cast on 90 (104) sts. with color 1 and work Stockinette stitch.  
 Knit to Row 96 (104).  
 SHAPE ARMHOLE: ON EACH SIDE bind off  
 3 sts. 1x, 2 sts. 1x, 1 st. 3x.  
 (4 sts. 1x, 3 sts. 1x, 2 sts. 1x, 1 st. 2x).  
 After Row 136 (146), SHAPE  
 SHOULDER: ON EACH SIDE, bind off  
 9 sts. 1x, 10 sts. 1x.  
 (11 sts. 1x, 12 sts. 1x).  
 After Row 140 (150), bind off  
 the remaining sts.

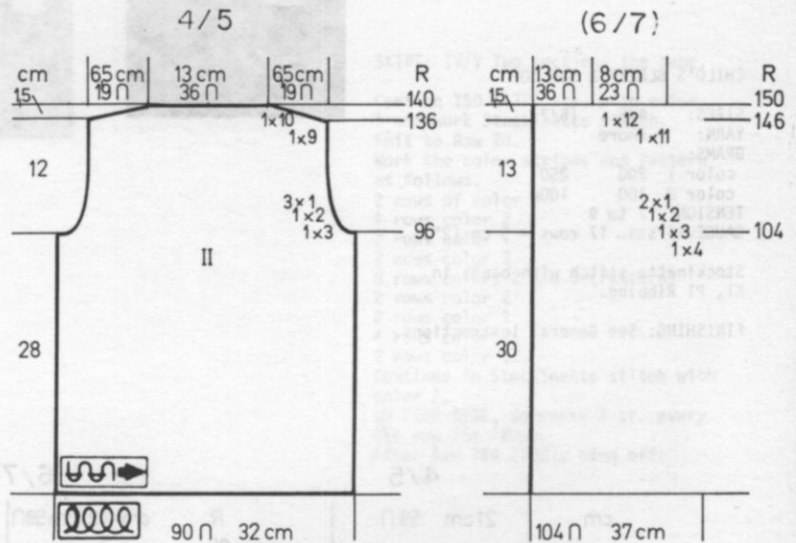

JACKET SLEEVES: III

Cast on 48 (54) sts. with color 1 and work Stockinette stitch.  
 After Row 14, ON EACH SIDE, increase  
 1 st. every 8th row 10x.  
 After Row 100 (108) SHAPE CAP:  
 ON EACH SIDE, bind off  
 2 sts. 3x, 1 st. 10x, 2 sts. 2x,  
 3 sts. 2x.  
 (2 sts. 3x, 1 st. 11x, 2 sts. 2x,  
 3 sts. 2x).  
 After Row 134 (144), bind off the  
 remaining sts.

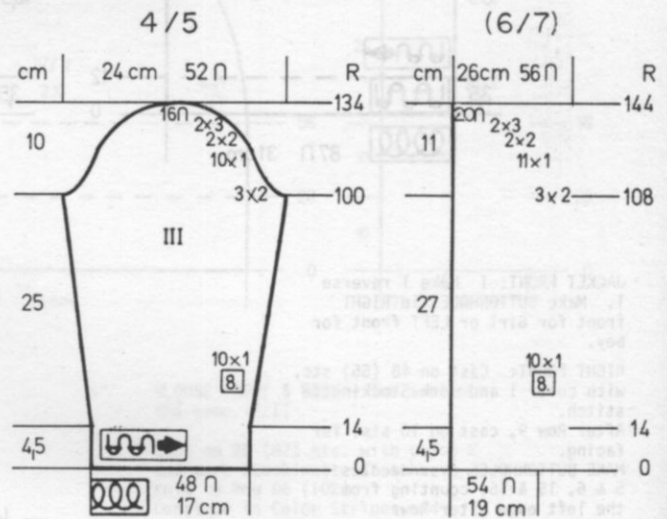

JACKET COLLAR: VI

Cast on 45 sts. with color 1 and work Stockinette stitch  
 ON EACH SIDE, cast on 3 sts. 3x.  
 After Row 29, ON EACH SIDE  
 bind off 3 sts. 3x.  
 After Row 34, bind off the  
 remaining sts.

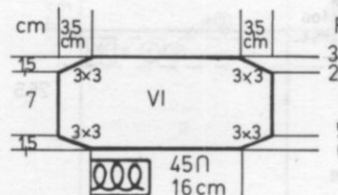



GIRL'S PULLOVER

SIZES: 6/7 (8/10)

YARN: Amore

GRAMS:  
 color 1 100 150  
 color 2 50 50  
 color 3 50 50  
 color 4 50 50  
 color 5 50 50

TENSION: 8 or 9 for Pattern  
 5 or 6 for Ribbing.

GAUGE:  
 Pat: 10 sts, 27 rows = 5 cm (2")  
 Rib: 1 1/2 sts, 17 rows = 5 cm (2")

A Tuck Stitch Pattern. Punch your own Card and push in both Tuck Buttons. Bands are K1, P1 Ribbing.

FINISHING: See General Instructions.  
 Work 4 rows single crochet around neckline.

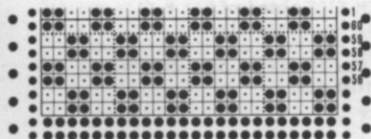

REPEAT THE PATTERN THROUGH ROW 37 then punch 2 rows of holes for connecting Card.

SLEEVES: III

Cast on 80 (86) sts, with color 1 and work in Ribbing.  
 ON EACH SIDE, increase 1 st. every 6th row 4x.  
 After Row 56 (62), ON EACH SIDE, bind off 24 sts.  
 After Row 84 (94), bind off the remaining sts.

6/7

(8/10)

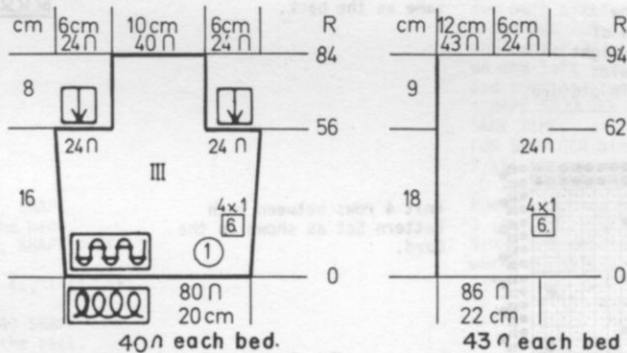

6/7

(8/10)

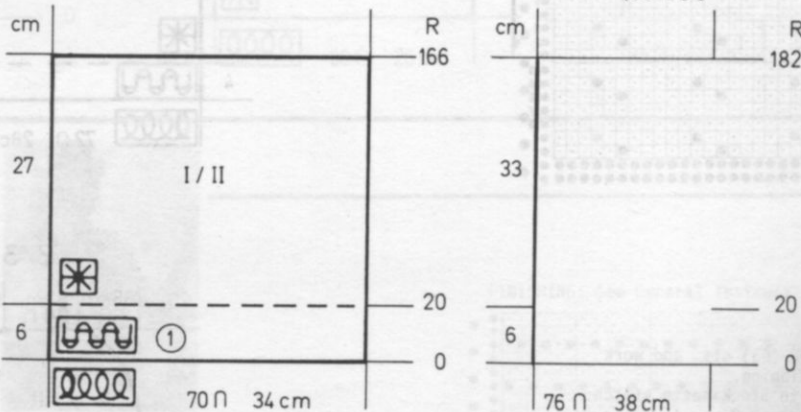

BACK & FRONT: I/II Two sections the same.

Cast on 70 (76) sts, and work 20 rows Ribbing with color 1. Continue in Tuck Stitch Pattern working REPEATED COLOR STRIPES of 16 Rows of colors 2, 3, 4, 5. After Row 166 (182), bind off.



GIRL'S SHORT SLEEVED SWEATER

SIZES: 2/3 (4)  
 YARN: Amore  
 GRAMS: 150 150  
 TENSION: 8 or 9  
 GAUGE: 12 1/2 sts. 17 1/2 rows = 5 cm.

A Lace Pattern. Punch your own Card and knit 4 rows between each Pattern set as marked on the Card. Sleeves are Stockinette stitch. Bands are K1, P1 Ribbing.

FINISHING: See General Instructions. Ease Cap of sleeve into armhole. Single crochet down fronts and neckline then work 1 row half double crochet, 1 row double crochet then 1 row of single crochet from from right to left. Work 5 buttonholes on right front as shown in picture.

RIGHT FRONT: I Make 1, reverse 1.

Cast on 36 (38) sts. and work 16 rows Ribbing. Continue in Lace Pattern. After Row 54 (62), ON THE LEFT (right for 2nd section), decrease 1 st. every 4th row 12x (13x) BUT AT THE SAME TIME after Row 70 (78) SHAPE SHOULDER same as the back.

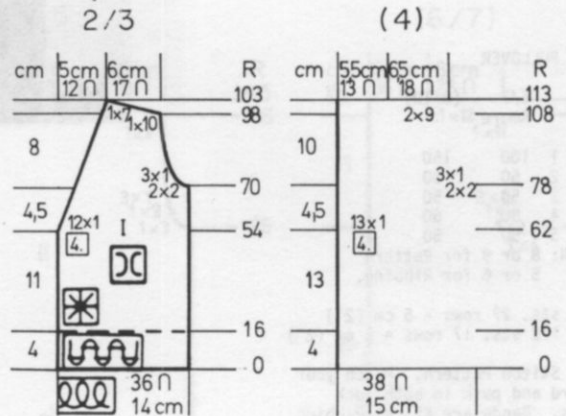

BACK: II

Cast on 72 (76) sts. and work 16 rows Ribbing. Continue in Lace Pattern. After Row 70 (78), SHAPE ARMHOLE: ON EACH SIDE, bind off 2 sts. 2x, 1 st. 3x for both sizes. After Row 98 (108), SHAPE SHOULDER: ON EACH SIDE, bind off 10 sts. 1x, 7 sts. 1x. (9 sts. 2x). After Row 103 (113) bind off the remaining sts.

Knit 4 rows between each Pattern Set as shown on the Card.

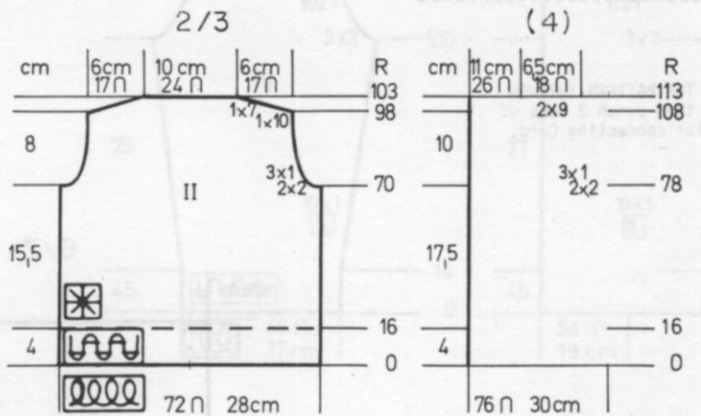
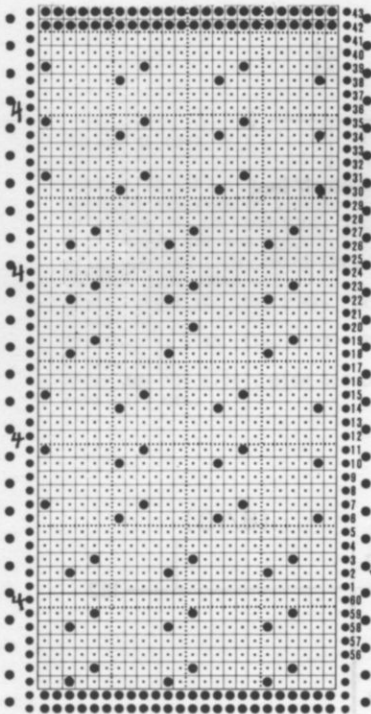

SLEEVES:

Cast on 60 (63) sts. and work 14 rows Ribbing. Continue in Stockinette stitch. Put Counter at 0. After Row 14, ON EACH SIDE, bind off 3 sts. then SHAPE CAP: ON EACH SIDE, decrease 1 st. every 2nd row 15x (16x). After Row 52 (54), bind off the remaining sts.

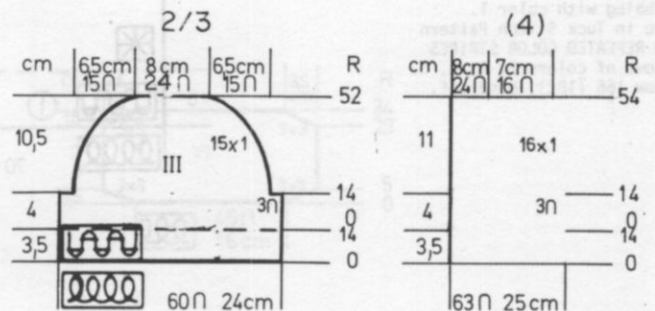

# KK 1021



## GIRL'S VEST

SIZES: 2/3 (4)  
 YARN: Amore  
 GRAMS:  
 color 1 100 150 White  
 color 2 50 50 Pale green  
 Small amounts of Blue, Yellow, Rose  
 not included in Kit.  
 TENSION: 8 or 9  
 GAUGE: 14 sts. 18 rows = 5 cm (2")

A multiple Stripe Pattern with 9 sts. on the main Machine and 1 st. on the Ribber - repeated across the machine.

FINISHING: See General Instructions.  
 With color 1, work 1 row single crochet then work 1 row single crochet with color 2 and 1 row Shell st. with color 2 as follows:  
 5 double crochet in 3rd st. from edge, \*skip 4 single crochets, 5 double crochets in next st.  
 REPEAT FROM \* around.  
 Work 1 row slip st. crochet around with color 1  
 Make a twisted cord using 8 strands of rose. Pull cord through crochet at neckline.

FRONT: I Make 1, reverse 1.

Cast on 40 (42) sts. with color 1, setting up the Pattern with 9 sts. on main machine and 1 st. on Ribber. Work the color stripes same as for the back.

After Row 72 (82), SHAPE ARMHOLE same as the back.  
 After Row 83 (97), SHAPE NECK:  
 Bind off  
 3 sts. 1x, 2 sts. 4x, 1 st. 5x for both sizes.  
 After Row 100 (114) SHAPE SHOULDER same as the back.

BACK: 11

Cast on 80 (84) sts. with color 1 and work in Ribbing Pattern with 9 sts. on main machine and 1 st. on the Ribber repeated across. Work color stripes as follows:  
 16 rows color 1 (White)  
 \*2 rows Blue  
 14 rows Color 1 (White)  
 2 rows Yellow  
 14 rows Color 1 (White)  
 2 rows Rose  
 14 rows Color 1 (White)  
 2 rows Green  
 14 rows Color 1 (White)  
 REPEAT THE COLOR STRIPES FROM \*.  
 After Row 72 (82) SHAPE ARMHOLE:  
 ON EACH SIDE, bind off  
 3 sts 1x, 2 sts. 2x, 1 st. 3x for both sizes.  
 After Row 100 (114), bind off the center 22 sts., put the needles on the left into holding position and complete the right side first.  
 \*SHAPE SHOULDER AND NECK AT THE SAME TIME.  
 FOR SHOULDER bind off  
 7 sts. 2x.  
 (8 sts. 2x).  
 FOR NECK, bind off  
 3 sts. 1x, 2 sts. 1x for both sizes.  
 Bring the needles on the left into working position, knit 1 row to the left side, turn the Row Counter back to 100 (114) and complete the left half. Follow the Instructions from \*.

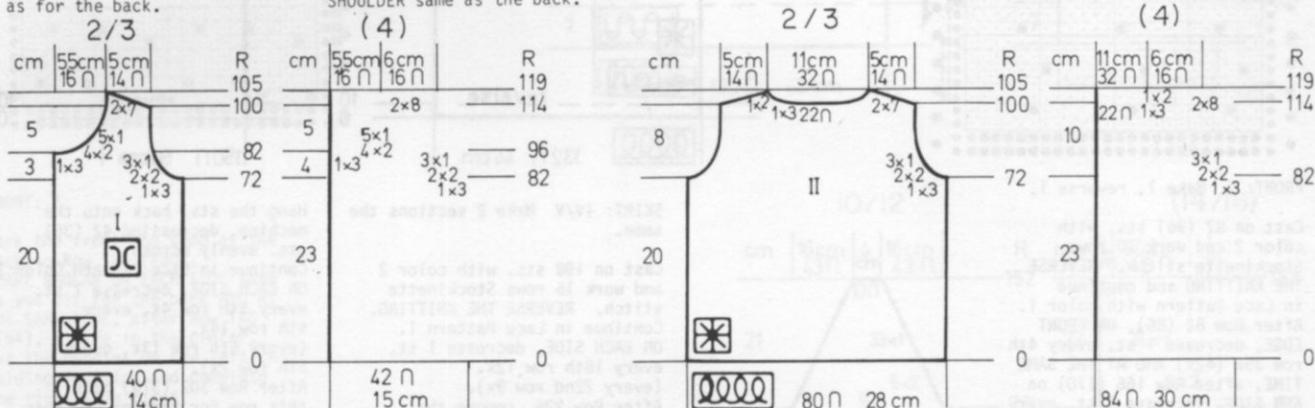

# DK 1022



## WOMAN'S TWO PIECE DRESS

SIZES: 8/10 (12/14)  
 YARN: Vienna = color 1  
 Capriccio = color 2  
 GRAMS:  
 color 1 600 700  
 color 2 4 balls for both sizes.

A Lace Pattern. Punch your own Cards. Bands are Stockinette stitch on the Purl side. Collar is lace.

## PATTERN II

840, 881 machine owners can use Lace Card No. 20 of original set of cards. Other machine owners Punch your own Card and REPEAT for at least 6 rows of holes. Always knit 4 rows between eyelets.

FINISHING: See General Instructions.

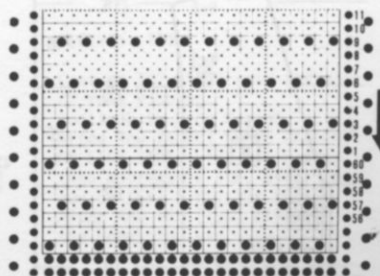

# DK 1022

PATTERN I

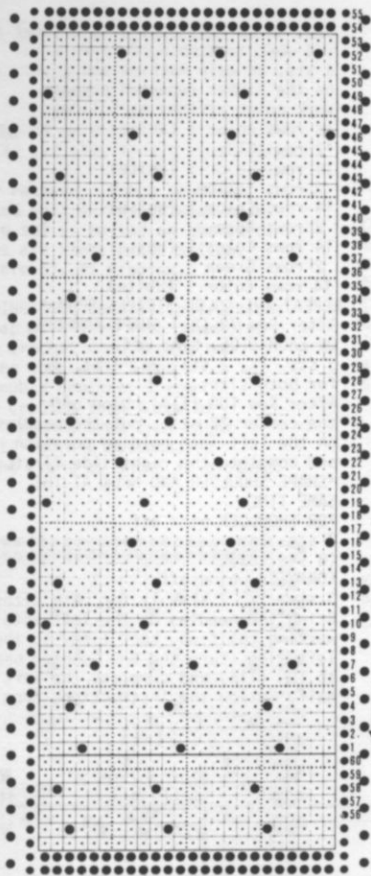

FRONT: I Make 1, reverse 1.

Cast on 87 (96) sts. with color 2 and work 10 rows Stockinette stitch. REVERSE THE KNITTING and continue in Lace Pattern with color 1. After Row 82 (86), ON FRONT EDGE, decrease 1 st. every 4th row 39x (42x) AND AT THE SAME TIME, after Row 166 (170) on ARM SIDE, increase 1 st. every 12th row 6x. After Row 238 (246) SHAPE SHOULDER same as the back.

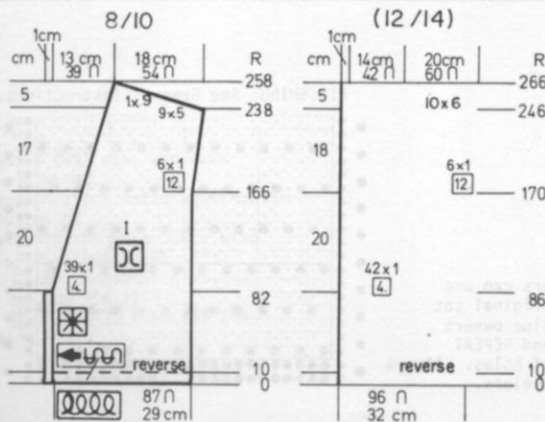

ARMBANDS: Make 2.

With Color 2, cast on 90 (96) sts. and work 12 rows Stockinette stitch. Bind off.

FRONT BANDS: Make 2.

Cast on 45 sts. with color 2 and work 12 rows Stockinette stitch. Bind off.

RUFFLE COLLAR

With color 2, pick up 200 sts. and work in Lace Pattern II. Knit 4 rows BETWEEN EACH SET OF HOLES and after Row 8, turn Tension 1 number higher after every 4 rows of knitting. AT THE SAME TIME, work SHORT ROWS at 1 end, 3 sts. 10x in holding position. After Row 24, REVERSE THE KNITTING then work Stockinette stitch to Row 36 (12 rows). Bind off loosely.

BACK: II

Cast on 132 (150) sts. with color 2 and work 10 rows Stockinette stitch. REVERSE THE KNITTING. Change to Color 1. Continue in Lace Pattern. After Row 155 (170), ON EACH SIDE, increase 1 st. every 12th row 6x for both sizes. After Row 238 (246) SHAPE SHOULDER AND WATCH FOR NECK SHAPING. FOR SHOULDER, bind off ON EACH SIDE, 5 sts. 9x, 9 sts. 1x (6 sts. 10x) AT THE SAME TIME, after Row 250 (258), bind off the center 26 (32) sts., put the needles on the left into holding position and complete the right side first. \*ON NECK SIDE, bind off 3 sts. 1x, 2 sts. 1x for both sizes. Bring the needles on the left into working position, knit 1 row in Pattern to the left side, turn the Row Counter back to 250 (258) and complete the left half. Follow the instructions from \* and don't forget to complete the shoulder shaping.

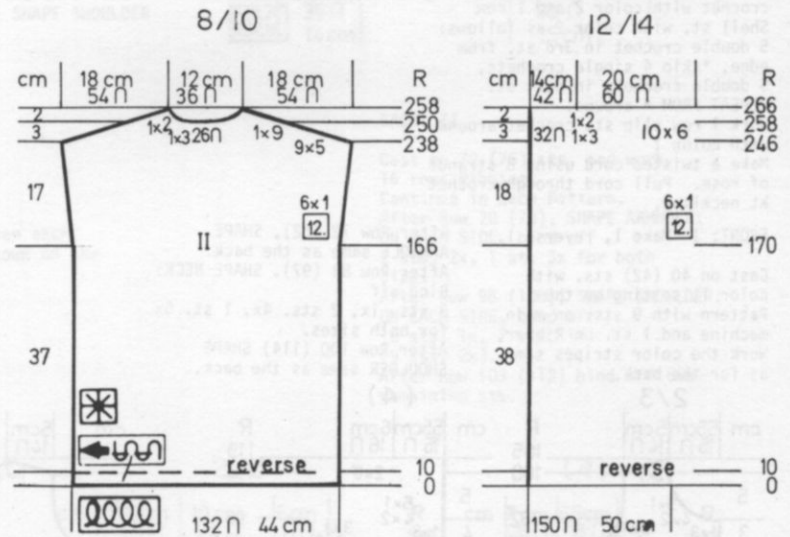

SKIRT: IV/V Make 2 sections the same.

Cast on 198 sts. with color 2 and work 16 rows Stockinette stitch. REVERSE THE KNITTING. Continue in Lace Pattern I. ON EACH SIDE, decrease 1 st. every 18th row 12x. (every 22nd row 9x). After Row 226, remove the knitting onto waste yarn.

Hang the sts. back onto the machine, decreasing 42 (36) sts. evenly across. Continue in Lace Pattern. Color 1. ON EACH SIDE, decrease 1 st. every 5th row 4x, every 4th row 14x. (every 6th row 13x, every 5th row 2x). After Row 302 (314) mark this row for hanging hem then work Stockinette stitch to Row 318 (330). Hang the marked row for hem and bind off.

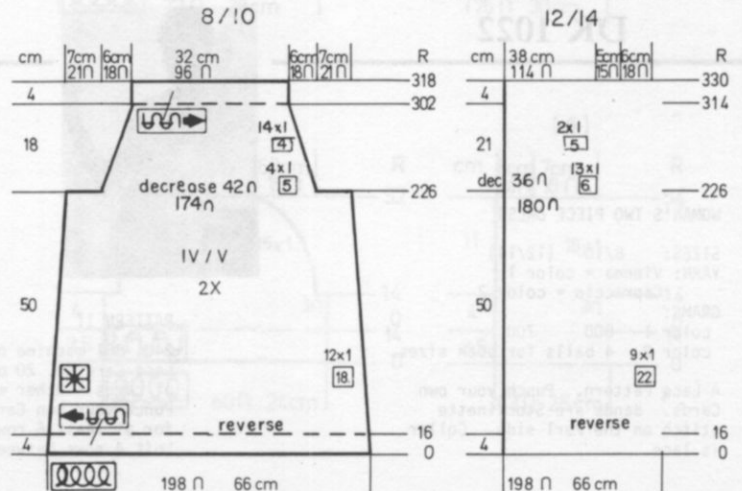



# DK 1023



## WOMAN'S PULLOVER

SIZES: 10/12 (14/16)  
 YARN: Amore  
 GRAMS: 250 300  
 TENSION: 8 or 9  
 GAUGE: 13 1/2 sts, 18 rows = 5 cm (2")

A Lace Pattern. Punch your own Card. Bands are K1, P1 Ribbing.

FINISHING: See General Instructions.

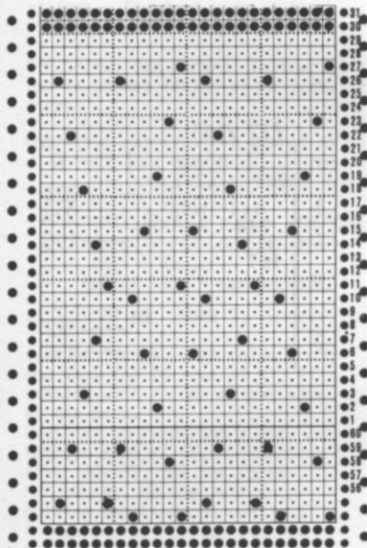

## NECKBAND:

Cast on 166 sts. and work K1, P1 Ribbing.  
 ON EACH SIDE, decrease 1 st. every 2nd row 5x. Bind off or remove onto contrast waste yarn after Row 12.

## BACK: II

Cast on 130 (140) sts. and work 28 rows Ribbing.  
 Continue in Lace Pattern.  
 After Row 126 (130), SHAPE RAGLAN: ON EACH SIDE, bind off 3 sts. then decrease 1 st. every 2nd row 36x (40x) every 3rd row 2x (1x). After Row 208 (214) bind off the remaining sts.

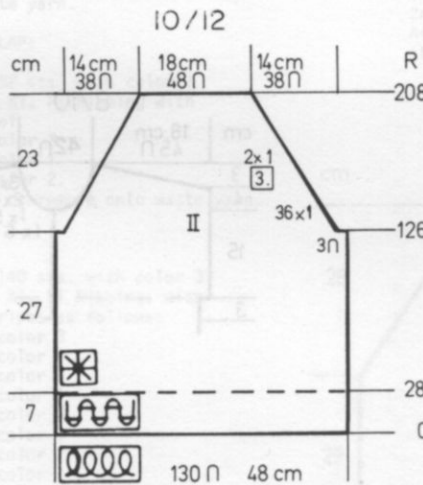

## FRONT: I

Work the front the same as the back to Row 126 (130).  
 SHAPE RAGLAN ON EACH SIDE as you did for the back AND AT THE SAME TIME, after Row 148 (154), divide in the center. Put the needles on the left into holding position and complete the right side first.  
 \*ON NECK SIDE, decrease 1 st. every 2nd row 16x (18x), every 4th row 8x (8x). At Row 208 (214) this side is completed. Bring the needles on the left into working position, knit 1 row in Pattern to the left side, turn the Row Counter back to 148 (154) and complete the left half. Follow the instructions from \*.

## 10/12

## (14/16)

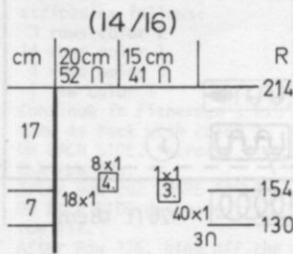
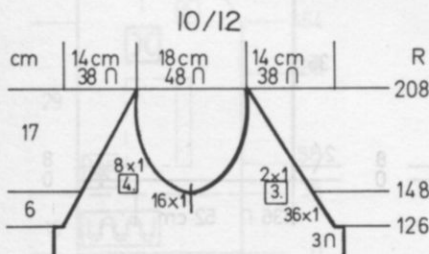
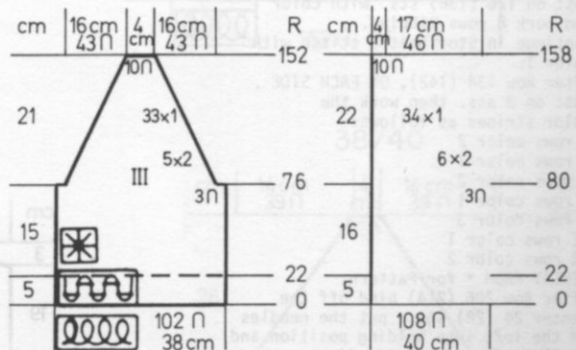

## SLEEVES: III

Cast on 102 (108) sts. and work 22 rows Ribbing.  
 Continue in Lace Design.  
 After Row 76 (80) SHAPE RAGLAN: ON EACH SIDE, bind off 3 sts. then decrease 2 sts. every 2nd row 5x (6x) 1 st. 33x (34x). After Row 152 (158) bind off the remaining sts.

# DK 1024



## WOMAN'S TENNIS SHIRT

SIZES: 8/10 (12/14)  
 YARN: Amore  
 GRAMS:  
 color 1 150 200  
 color 2 50 50  
 color 3 50 50  
 TENSION: 7 to 9  
 GAUGE: 13 sts. 19 rows = 5 cm (2")

Stockinette stitch with color stripes. Bands are K1, P1 Ribbing.

FINISHING: See General Instructions.  
 Sew in a 7" zipper on front neck opening.

### FRONT: I

Work the front the same as the back to Row 122 (130).  
 Divide in the center and put the needles on the left into holding position and complete the right side first.  
 \*After Row 134 (142) cast on 3 sts. Work in Stripe Pattern same as the back.  
 After Row 191 (197) ON NECK SIDE bind off  
 6 sts. 1x, 5 sts. 1x, 4 sts. 2x, 1 st. 3x.  
 (7 sts. 1x, 5 sts. 1x, 4 sts. 2x, 1 st. 4x).  
 After Row 206 (214) SHAPE SHOULDER same as the back.  
 Bring the needles on the left into working position, knit 1 row in Pattern to the left side, turn the Row Counter back to 122 (130) and complete the left half. Follow the instructions from \*.

### BACK: II

Cast on 126 (136) sts. with color 1 and work 8 rows Ribbing.  
 Continue in Stockinette stitch with color 1.  
 After Row 134 (142), ON EACH SIDE cast on 3 sts. then work the color stripes as follows:  
 2 rows color 2  
 2 rows color 1  
 2 rows color 2  
 2 rows color 1  
 4 rows color 3  
 \*2 rows color 1  
 2 rows color 2  
 REPEAT FROM \* for Pattern.  
 After Row 206 (214) bind off the center 24 (28) sts., put the needles on the left into holding position and complete the right side first.  
 \*SHAPE SHOULDER AND NECK AT THE SAME TIME.  
 FOR SHOULDER, bind off  
 9 sts. 5x.  
 (10 sts. 4x, 7 sts. 1x).  
 FOR NECK, bind off  
 3 sts. 1x, 2 sts. 2x, 1 st. 2x.  
 (4 sts. 1x, 2 sts. 2x, 1 st. 2x).  
 Bring the needles on the left into working position, knit 1 row in Pattern to the left side, turn the Row Counter back to 206 (214) and complete the left half. Follow the instructions from \*.

### NECKBAND:

Cast on 182 (188) sts. with color 3 and work 20 rows Ribbing.  
 Bind off or remove onto contrast waste yarn.

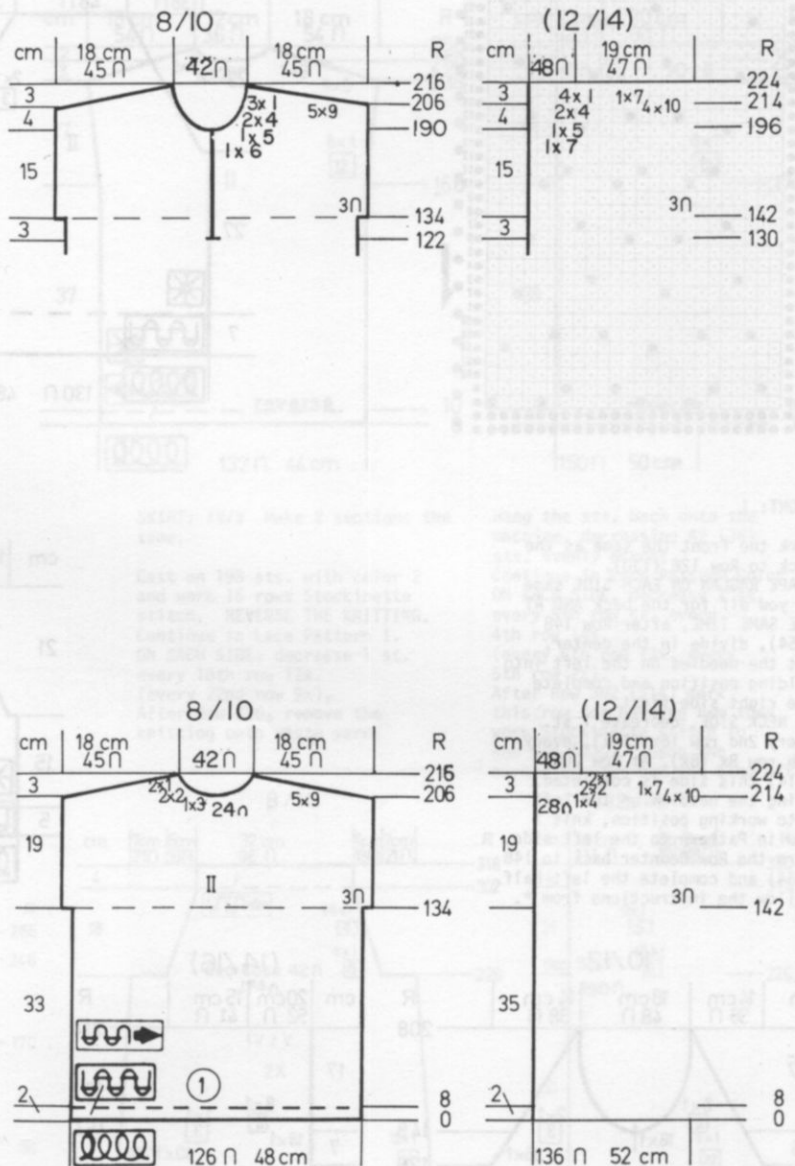



## MAN'S ZIPPERED JACKET

SIZE: 38/40  
 YARN: Fortissima plus Amore  
 GRAMS:  
 color 1 400 = Fortissima  
 color 2 150  
 color 3 100  
 TENSION: 7 to 9  
 GAUGE: 14 sts. 22 rows = 5 cm (2")

Half Fisherman's Rib Pattern with bands in K1, P1 Ribbing and color stripes. The Purl side is the right side.

FINISHING: See General Instructions. Sew in pocket lining and a Jacket type zipper.

NOTE: THE PATTERN IS A REPEAT OF \*13 rows Half Fisherman's Rib (Push in LEFT TUCK BUTTON ON THE KNITTER). Release Tuck Button and push in BOTH PART BUTTONS then KNIT 1 Row. REPEAT FROM \* for Pattern.

LEFT FRONT: I Make 1, reverse 1

Cast on 76 sts. with color 2 and work the 36 rows of K1, P1 Ribbing with color stripes same as the back. Continue in Fisherman's Rib Pattern same as back with color 1. After Row 58, for the Pocket, Put 54 sts. on the left into holding position and continue in Pattern to Row 128 over 22 sts. then put these sts. into holding position and bring the 54 sts. into work. Put Counter at 58 and work in Pattern to Row 128 then work over ALL NEEDLES. After Row 164 SHAPE RAGLAN. Decrease 1 st. every 4th row 8x, every 2nd row 45x, AND AT THE SAME TIME, after Row 253, SHAPE NECK: Bind off 4 sts. 1x, 3 sts. 1x, 2 sts. 5x, 1 st. 6x.

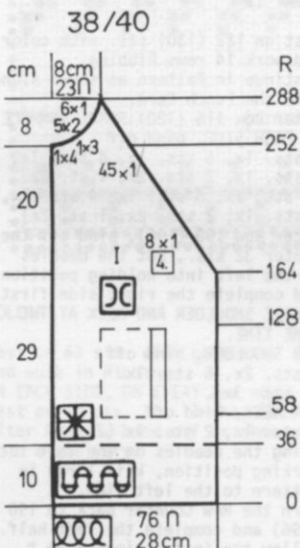

POCKET LININGS: Make 2.

Cast on 38 sts. with color 1 and work approximately 38 rows Stockinette stitch. Remove onto waste yarn.

POCKET FLAP:

Cast on 52 sts. with color 3 and work K1, P1 Ribbing with stripes of  
 4 rows color 3  
 4 rows color 1  
 4 rows color 2.  
 Bind off or remove onto waste yarn.

COLLAR:

Cast on 140 sts. with color 3 and work K1, P1 Ribbing. with color stripes as follows:  
 4 rows color 3  
 10 rows color 1  
 4 rows color 2  
 10 rows color 1  
 8 rows color 3  
 10 rows color 1  
 4 rows color 2  
 10 rows color 1  
 4 rows color 3  
 Beginning with the 4 rows of color 3, work the color stripes backwards.  
 Bind off or remove onto waste yarn.

SLEEVES: III

Cast on 90 sts. with color 2 and work K1, P1 Ribbing with color stripes as follows:  
 3 rows color 2  
 14 rows color 1  
 4 rows color 3  
 1 row color 1  
 Continue in Fisherman's Rib Pattern same as back with color 1. ON EACH SIDE, increase 1 st. every 8th row 22x. After Row 202 SHAPE RAGLAN. ON EACH SIDE decrease 1 st. every 2nd row 61x. After Row 326, bind off the remaining sts.

BACK: II

Cast on 152 sts. with color 2 and work K1, P1 Ribbing with color stripes of  
 3 rows color 2  
 10 rows color 1  
 4 rows color 3  
 4 rows color 2  
 10 rows color 1  
 4 rows color 3  
 1 row color 1

Continue in Fisherman's Rib Pattern as given in NOTE (color 1). Knit to Row 164.

SHAPE RAGLAN: ON EACH SIDE, decrease 1 st. every 4th row 8x, 1 st. every 2nd row 45x. After Row 288, bind off the remaining sts.

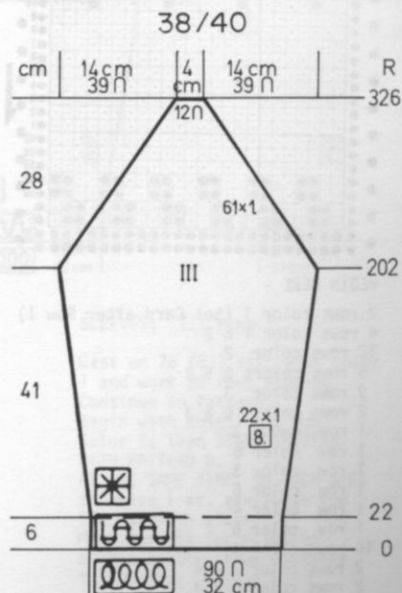
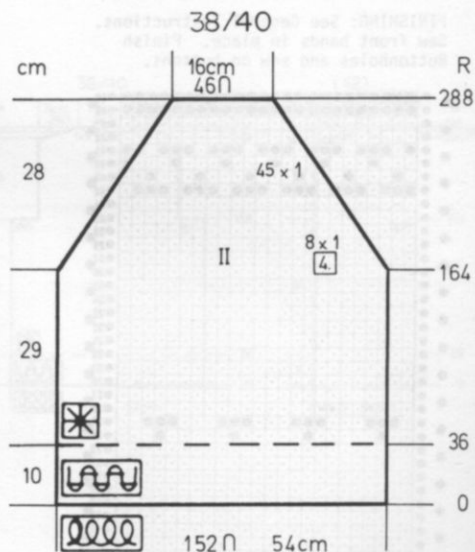



WOMAN'S VEST

SIZES: 10/12 (14)  
 YARN: NO KIT AVAILABLE  
 GRAMS: (Any yarn to give Gauge).  
 color 1 100 100 = Blue  
 color 2 100 100 = Brown  
 color 3 50 50 = Green  
 color 4 50 50 = Lt. Blue  
 color 5 = White } Small amounts  
 color 6 = Rust } of 3 colors.  
 color 7 = Yellow }  
 TENSION: 8 or 9  
 GAUGE: 13 sts. 16 rows = 5 cm (2")

Norwegian Designs combined with Stockinette stitch. Punch your own Card. Bands are K1, P1 Ribbing.

FINISHING: See General Instructions. Sew front bands in place. Finish Buttonholes and sew on buttons.

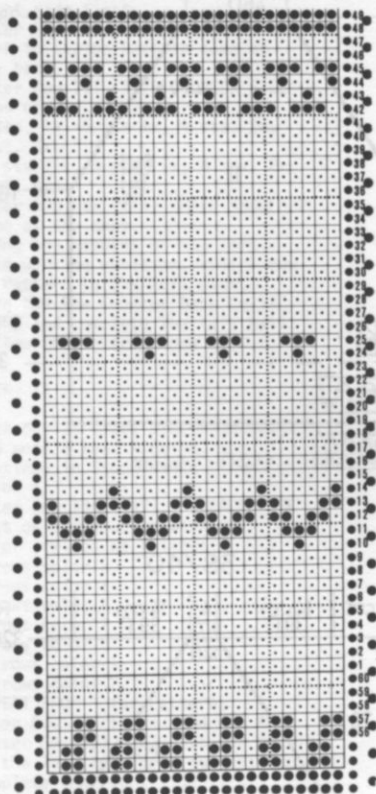

BEGIN HERE -

- 2 rows color 1 (Set Card after Row 1)
  - 4 rows color 1 & 2
  - 12 rows color 2
  - 5 rows colors 5 & 3
  - 9 rows color 3
  - 2 rows color 6 & 3
  - 1 row color 3
  - 1 row color 6
  - 1 row color 3
  - 1 row color 6
  - 1 row color 4
  - 1 row color 6
  - 16 rows color 4
  - 2 rows color 7 & 4
  - 2 rows color 5 & 4
- REPEAT FROM BEGINNING.

NECKBAND:

Sew shoulder seams first then pick up 99 sts. around neckline. ON EACH SIDE, hang the 7 band sts. held on waste yarn (leave the 8th for seaming to fronts). Work in K1, P1 Ribbing for 10 rows and work a buttonhole on right front after Row 5 (6). Bind off.

ARMBANDS: Make 2.

Cast on 112 (118) sts. with color 1 and work 10 rows Ribbing. Bind off or remove onto contrast waste yarn.

FRONT: II Make 1, reverse 1 and omit Buttonholes in 2nd section.

Cast on 65 (69) sts. with color 1 and work in Ribbing. After Row 8, make BUTTONHOLE over needles 5 and 6 counting from the LEFT edge. After Row 14, remove 7 end sts. on the left side onto waste yarn. After Row 14, continue in Pattern same as for the back. After Row 116 (120) SHAPE ARMHOLE same as the back. After Row 169 (175) SHAPE NECK: Bind off 5 sts. 1x, 3 sts. 2x, 2 sts. 2x, 1 st. 3x for both sizes. After Row 190 (196) SHAPE SHOULDER same as the back.

Pick up the 7 sts. for band that are held on waste yarn and hang them back onto the machine, Increase 1 st. on inner edge for seam, then work in K1, P1 Ribbing. Put Counter at 8. Make 5 more buttonholes over needles 5 and 6 EVERY 27th Row 5x (EVERY 28th Row 5x) After Row 168 (174) remove these sts. onto contrast waste yarn. Work the left front section with reverse shaping and omit the buttonholes.

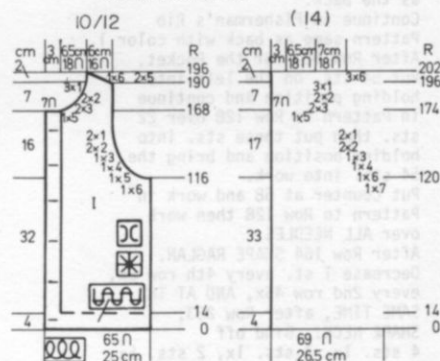

BACK: II

Cast on 122 (130) sts. with color 1 and work 14 rows Ribbing. Continue in Pattern as shown along side the Punch Card. After Row 116 (120) SHAPE ARMHOLE: ON EACH SIDE, bind off 6 sts. 1x, 5 sts. 1x, 4 sts. 1x, 3 sts. 1x, 2 sts. 2x, 1 st. 2x. (7 sts. 1x, 6 sts. 1x, 4 sts. 1x, 3 sts. 1x, 2 sts. 2x, 1 st. 2x). After Row 190 (196), bind off the center 32 sts., put the needles on the left into holding position and complete the right side first. \*SHAPE SHOULDER AND NECK AT THE SAME TIME. FOR SHOULDER, bind off 5 sts. 2x, 6 sts. 1x. (6 sts. 3x). FOR NECK, bind off 3 sts. 1x, 2 sts. 1x (2x). Bring the needles on the left into working position, knit 1 row in Pattern to the left side, turn the Row Counter back to 190 (196) and complete the left half. Follow the instructions from \*.

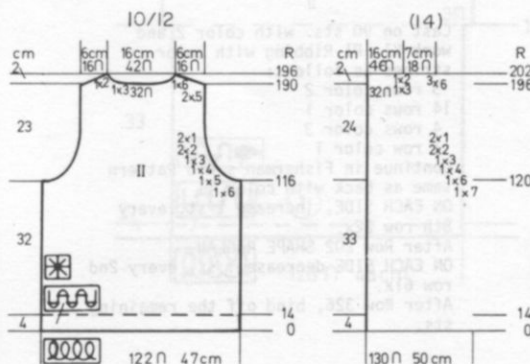



# DK 1028



## WOMAN'S PULLOVER

SIZES: 8/10 (12/14)

YARN: Amore

### GRAMS:

color 1	250	300
color 2	50	50
color 3	50	50
color 4	50	50

TENSION: 6 or 7

GAUGE: 15 1/2 sts. 18 rows = 5 cm (2")

An Intarsia Design. Bands are K1, P1 Ribbing. Follow the Chart for the changes in color.

FINISHING: See General Instructions. Fold over the 3 sts. at armhole edge and sew to the inside. Fold 3 rows at neck edge to the inside and sew in place.

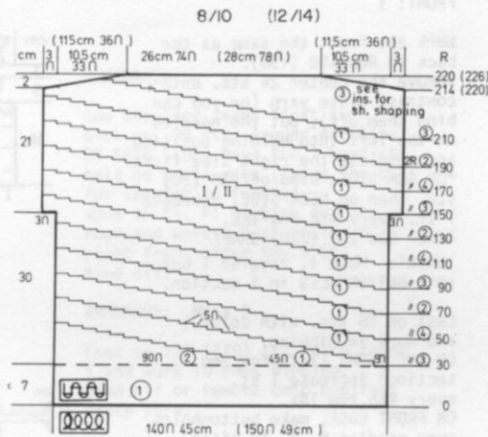

BACK & FRONT I/II Two sections the same.

Cast on 140 (150) sts. with color 1 and work 30 rows Ribbing. Continue in the Intarsia Design. Begin at right side. 5 sts. Color 3, 45 sts. color 1, 90 sts. color 2. Knit 2 rows. 5 sts. color 1, 5 sts. color 3, 45 sts. color 1, 85 sts. color 2. Knit 2 rows.

\*REPEAT the colors having 5 more sts. at left side until no more sts.\* (70 sts. left side).

At Row 50, begin with color 4 over 5 sts. and REPEAT from \* to \*. Continue to follow Chart, changing colors as shown. After Row 150, ON EACH SIDE cast on 3 sts.

After Row 214 (220), SHAPE SHOULDER: ON EACH SIDE, bind off 14 sts. 1x, 11 sts. 2x. (15 sts. 1x, 12 sts. 2x). After Row 220 (226), bind off the remaining sts.

# DK 1029



## WOMAN'S PULLOVER

SIZES: 10/12 (14)

YARN: Amore

### GRAMS:

color 1	300	350
color 2	100	100
color 3	50	50

TENSION: 4 to 6

GAUGE: 17 sts. 24 rows = 5 cm (2")

A Fairisle Pattern (Norwegian)

The bands are K1, P1 Ribbing. Punch your own Card and if you want to use your Color Changer, be sure to punch the card in reverse.

FINISHING: See General Instructions.

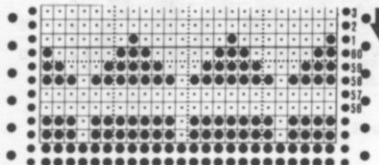

REPEAT THE PUNCH CARD THROUGH ROW 41, then Punch 2 rows of holes on Rows 44 and 45.

### NECKBAND:

FRONT: 60 sts.  
SIDES: 34 sts. (make 2)  
BACK: 58 sts.  
Cast on the required sts. for each section as shown above and with color 1 work K1, P1 Ribbing. After Row 6, ON EACH SIDE, decrease 1 st. EVERY ROW. After Row 12, bind off.

### FRONT: I

Work the front the same as the back to Row 182 (188). SHAPE ARMHOLE same as the back continuing in Stockinette stitch with color 1. After Row 250 (258), bind off the center 58 sts. for neck, put the needles on the left into holding position and complete the right side first. \*Knit to Row 274 (282) then SHAPE SHOULDER same as the back. Bring the needles on the left into working position, knit 1 row to the left side, turn the Row Counter back to 250 (258) and follow the instructions from \*.

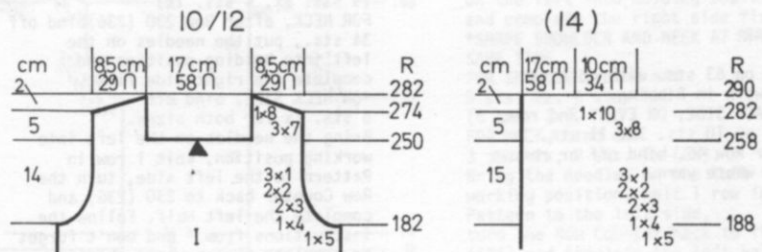

# DK 1029

BACK: II

Cast on 160 (170) sts. with color 1 and work 42 rows Ribbing. Continue in Pattern.

Begin with 2 rows color 1 and set the card on the 2nd row.

\*Work 2 rows color 1 & 3  
2 rows color 1  
4 rows color 1 & 2  
2 rows color 1

REPEAT FROM \*

Knit to Row 182, (188) then continue in color 1 and Stockinette stitch.

SHAPE ARMHOLE: ON EACH SIDE, bind off 5 sts. 1x, 4 sts. 1x, 3 sts. 2x, 2 sts. 2x, 1 st. 3x for both sizes.

After Row 274 (282), bind off the center 48 sts., put the needles on the left into holding position and complete the right side first.

\*SHAPE SHOULDER AND NECK AT THE SAME TIME.

FOR SHOULDER bind off

7 sts. 3x, 8 sts. 1x.

(8 sts. 3x, 10 sts. 1x).

FOR NECK, bind off

3 sts. 1x, 2 sts. 1x for both sizes.

Bring the needles on the left into working position,

knit 1 row to the left side

turn the Row Counter back

to 274 (282) and complete

the left half. Follow the

instructions from \*.

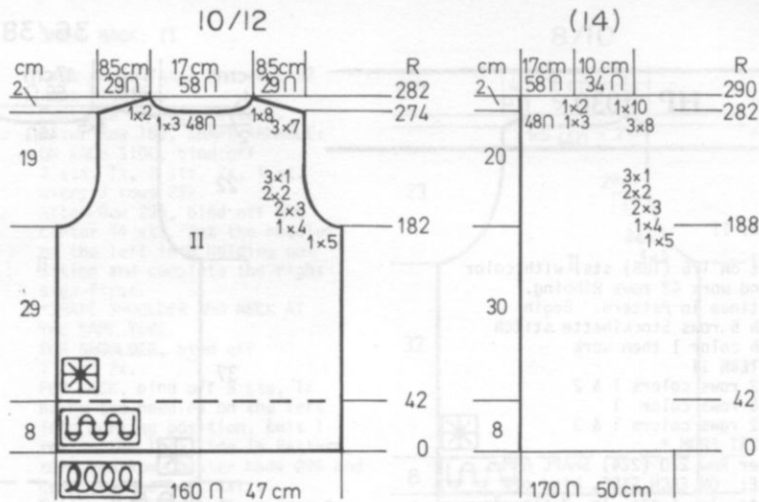

SLEEVES: III

Cast on 106 (116) sts. with color 1 and work 16 rows Ribbing.

Continue in Pattern beginning with 2 rows color 1.

Work 1 PATTERN SET, then

continue in Stockinette

stitch with color 1 BUT

AT THE SAME TIME ON EACH

SIDE, increase 1 st.

every 10th row 5x.

After Row 74 (78) SHAPE

CAP: ON EACH SIDE,

Please follow the bind-offs

on each side as shown on

the Chart for your size.

After Row 142 (150), bind

off the remaining sts.

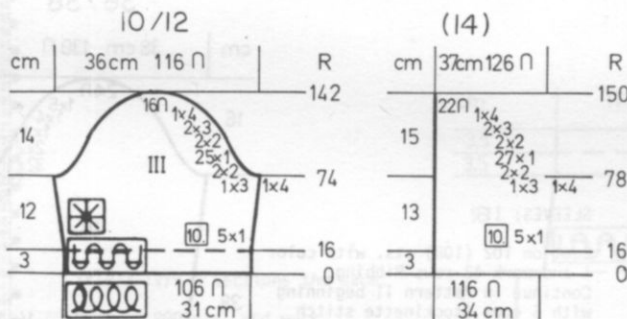

# HP 1030



MAN'S JACKET

SIZES: 36/38 (40)

YARN: Vienna

GRAMS:

color 1 550 600

color 2 100 100

color 3 100 100

TENSION: 4

GAUGE: 17 sts. 24 rows = 5 cm (2")

A Norwegian Design. Punch your

own Cards for Pattern I and II.

Bands are K1, P1 Ribbing.

FINISHING: See General Instructions.

Sew front bands in place and weave

neckband at center back and sew

to back neck. Finish buttonholes

and sew on buttons.

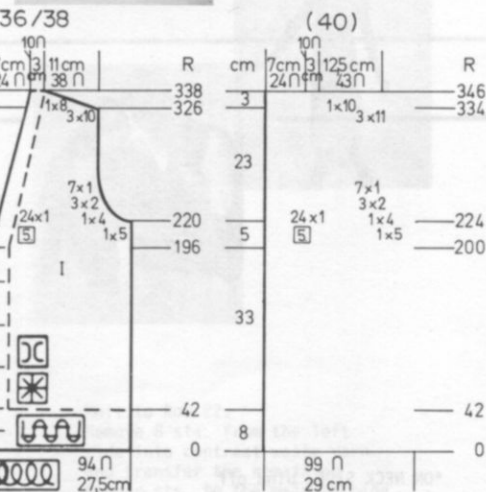
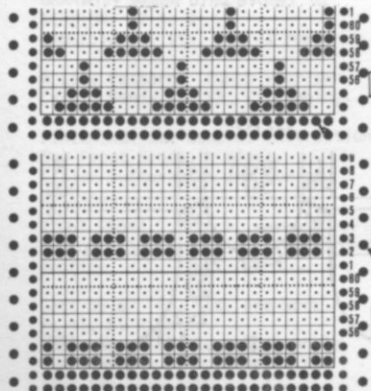

PATTERN I

REPEAT THE PUNCH CARD THROUGH 41, then punch 2 rows of holes for connecting card.

PATTERN II

REPEAT THE PUNCH CARD THROUGH ROW 35, then punch 2 rows of holes on Rows 42 and 43 for connecting Card.

RIGHT FRONT: I

Do not make buttonholes in this section.

Cast on 94 (99) sts. with color 1 and work 42 rows Ribbing.

Remove 10 sts. on the left onto contrast waste yarn and

continue in Pattern over the remaining sts. same as for

the back.

After Row 196 (200), ON FRONT

EDGE, decrease 1 st. every 5th

row 24x AND AT THE SAME TIME,

after Row 220 (224) SHAPE

ARMHOLE same as the back.

After Row 326 (334), SHAPE

SHOULDER same as the back.

Pick up the 10 sts. held on

waste yarn and put them back onto

machine. Continue in Ribbing.

Counter at 42. ADD 1 extra st.

ON INNER EDGE for seam.

Knit to Row 338, then 36 more

rows for back of neck.

remove onto contrast waste yarn.

FOR THE LEFT FRONT - REVERSE

SHAPING. When knitting the front

BAND, BE SURE TO MAKE BUTTONHOLES

over needles 4, 5, 6 after

ROWS 20, 55, 90, 125, 160, 195.

# HP 1030

BACK: II

Cast on 176 (186) sts. with color 1 and work 42 rows Ribbing. Continue in Pattern. Begin with 6 rows Stockinette stitch with color 1 then work PATTERN II

\*2 rows colors 1 & 2  
6 rows color 1  
2 rows colors 1 & 3

REPEAT FROM \*.

After Row 220 (224) SHAPE ARM-HOLE: ON EACH SIDE, bind off 5 sts. 1x, 4 sts. 1x, 2 sts. 3x, 1 st. 7x for both sizes BUT AT THE SAME TIME, AFTER ROW 226 (230) BEGIN PATTERN I. Work 16 rows PATTERN I with colors 1 & 3.

Continue in Stockinette stitch with color 1

After Row 326 (334), bind off the center 46 sts., put the needles on the left into holding position and complete the right side first.

\*ON NECK SIDE, bind off 5 sts.

1x for both sizes.

After Row 334 (342) SHAPE

SHOULDER, bind off

10 sts. 3x, 8 sts. 1x.

(11 sts. 3x, 10 sts. 1x).

Bring the needles on the left

into working position, knit 1 row

to the left side, turn the Row

Counter back to 326 (334)

and complete the left half.

Follow the instructions from \*.

SLEEVES: III

Cast on 102 (108) sts. with color 1 and work 42 rows Ribbing.

Continue in Pattern II beginning

with 6 rows Stockinette stitch

with color 1. Change colors

as given for BACK and FRONT.

AT THE SAME TIME, ON EACH SIDE,

increase 1 st. every 14th row

14x.

After Row 224 (228) SHAPE CAP:

Please follow the bind-offs for

Cap Shaping ON EACH SIDE by

following the Chart in your size.

36/38

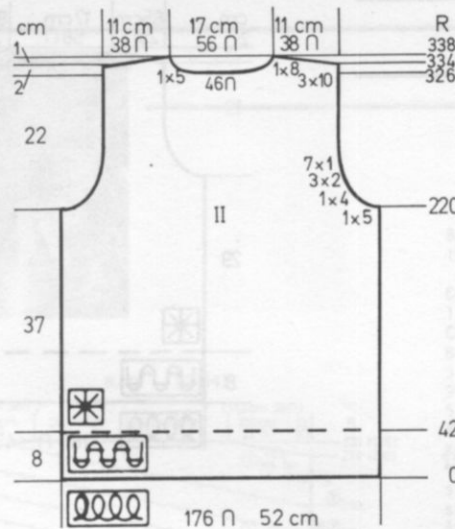

(40)

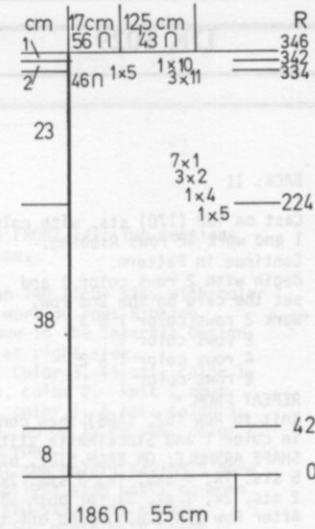

36/38

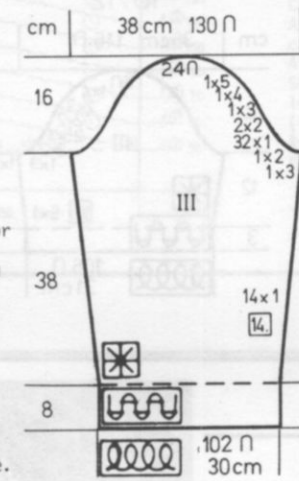

(40)

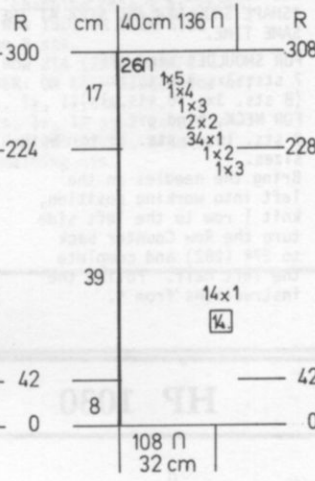

# DK 1031



WOMAN'S SHELL & SKIRT

SIZE: 8/10  
YARN: Amore  
GRAMS: 600  
TENSION: 3 to 5  
GAUGE: 17 sts. 24 rows = 5 cm (2")

The Skirt is Stockinette stitch with K1, P1 Ribbing at upper section. The Shell is a Lace Design. Punch your own Card. Bands are K1, P1 Ribbing.

FINISHING: See General Instructions. Make hem at waistline and pull elastic through casing of SKIRT.

SHELL FRONT: I

Work the front the same as the back to Row 186. SHAPE ARMHOLE ON EACH SIDE same as the back but after Row 258, bind off the center 16 sts., put the needles on the left into holding position and complete the right side first.

\*ON NECK SIDE, bind off 4 sts. 1x, 3 sts. 1x, 2 sts. 5x, 1 st. 6x. After Row 296, SHAPE SHOULDER same as the back. Bring the needles on the left into working position, knit 1 row to the left side in Pattern, turn the Row Counter back to 258 and complete the left half. Follow the instructions from \*.

NECKBAND:

Cast on 142 sts. and work 16 rows Ribbing. Bind off or remove onto waste yarn.

ARBANDS: Make 2.

Cast on 166 sts. and work 10 rows Ribbing. Bind off or remove onto waste yarn.

8/10

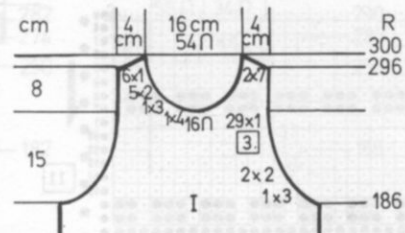



# DK 1031

KNIT 6 ROWS BETWEEN EACH COMPLETE PATTERN AS SHOWN ON LEFT SIDE OF PUNCH CARD.

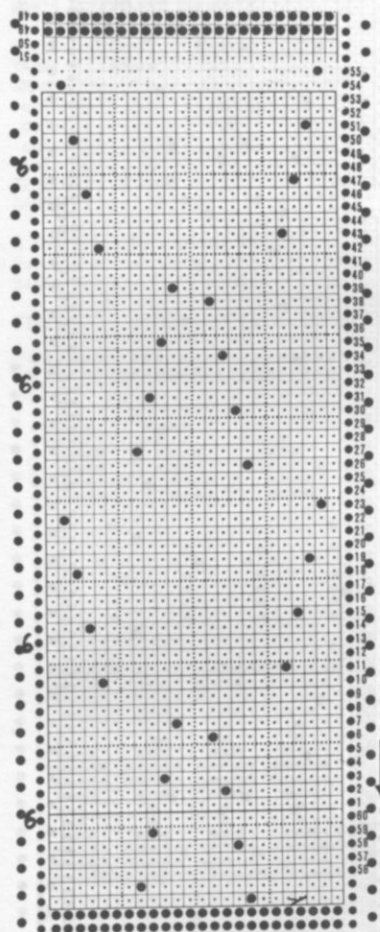

## SHELL BACK: II

Cast on 154 sts. and work 32 rows Ribbing.  
Continue in Lace Pattern.  
After Row 186, SHAPE ARMHOLE: ON EACH SIDE, bind off 3 sts. 1x, 2 sts. 2x, 1 st. every 3 rows 29x.  
After Row 296, bind off the center 44 sts. put the needles on the left into holding position and complete the right side first.  
\*SHAPE SHOULDER AND NECK AT THE SAME TIME.  
FOR SHOULDER, bind off 7 sts. 2x.  
FOR NECK, bind off 5 sts. 1x. Bring the needles on the left into working position, knit 1 row to the left side in Pattern, turn the Row Counter back 296 and complete the left half.  
Follow the instructions from \*.

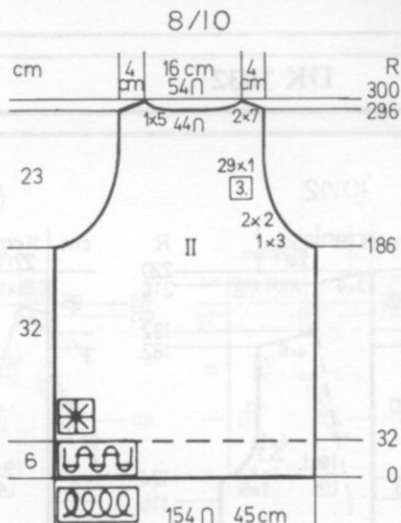

## SKIRT: IV/V 2 sections the same.

Cast on 200 sts. and work Stockinette stitch with normal Tension to Row 16 and hang the hem if you like. Continue in Stockinette stitch and ON EACH SIDE, decrease 1 st. every 22nd Row 10x.  
After Row 258, transfer every other stitch to the Ribber and with Lower Tension, work K1, P1 Ribbing.  
ON EACH SIDE, decrease 1 st. every 20th row 5x.  
After Row 354, make the row for hemline then knit to Row 398. Bind off or remove onto waste yarn.

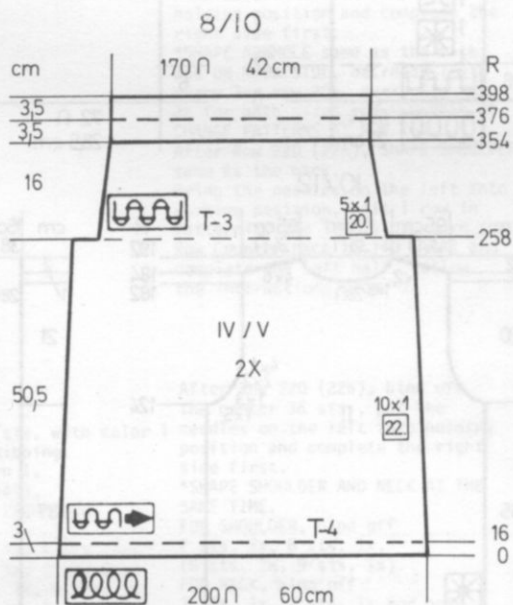

# DK 1032



## WOMAN'S JACKET

SIZES: 10/12 (14)  
YARN: Amore  
GRAMS: 400 500  
TENSION: 7 to 8  
GAUGE: 12 1/2 sts. 14 1/2 rows = 5 cm

A Lace Pattern. Punch your own Card. Bands are K1, P1 Ribbing.

FINISHING: See General Instructions. Sew Front Bands in place. Finish Buttonholes and sew on Buttons.

RIGHT FRONT: Make 1, reverse LEFT and omit Buttonholes in left front section.

Cast on 67 (72) sts. and work in K1, P1 Ribbing.  
After Row 12, make a Buttonhole over needles 4, 5, 6 counting from the LEFT edge.

Knit to Row 22.  
Remove 8 sts. from the left side into contrast waste yarn and transfer the remaining Ribber sts. to the main machine then continue in Lace Pattern.  
After Row 116 (124) ON FRONT EDGE, decrease 1 st. every 4th row 19x AND AT THE SAME TIME, after Row 124 (130) SHAPE ARMHOLE same as the back.  
After Row 182 (190), SHAPE SHOULDER.  
Bind off  
6 sts. 4x.  
(9 sts. 3x).

Pick up the sts. held on waste yarn and return them to the Ribber. Add 1 more st. to inner edge for seam. Turn tension down at least 1 number and put Counter at 22.  
Continue in K1, P1 Ribbing and MAKE BUTTHOLES over needles 4, 5, 6. counting from the left edge, after Rows 38, 64, 90, 116. INCREASE 1 st. ON INNER EDGE  
After Row 116 then every 4th row 19x in all (last increase when counter reads 188).  
Continue in Ribbing over the 28 sts. to Row 214, (222) then bind off 10 sts. 1x, 9 sts. 2x.  
(Chart says 3x9 but you have 1 added extra st. so bind it off with first bind off).

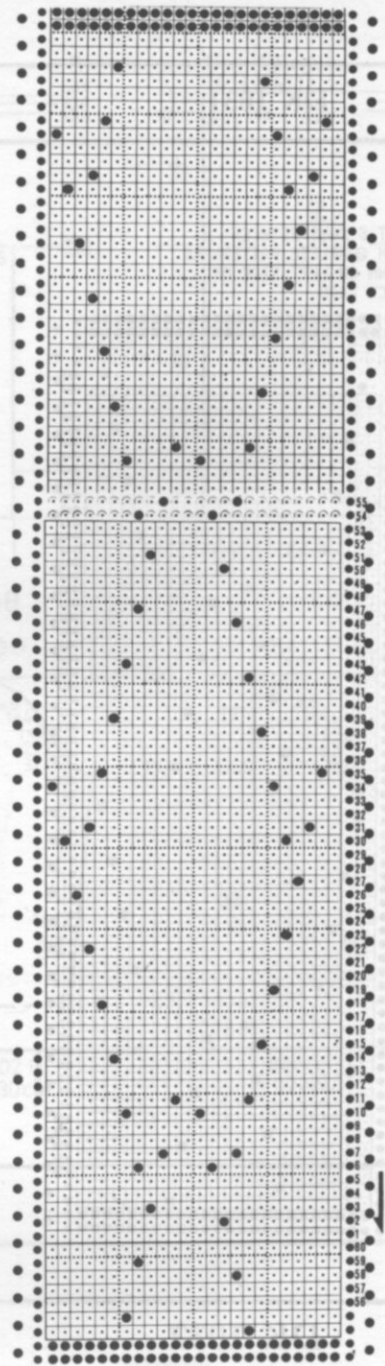
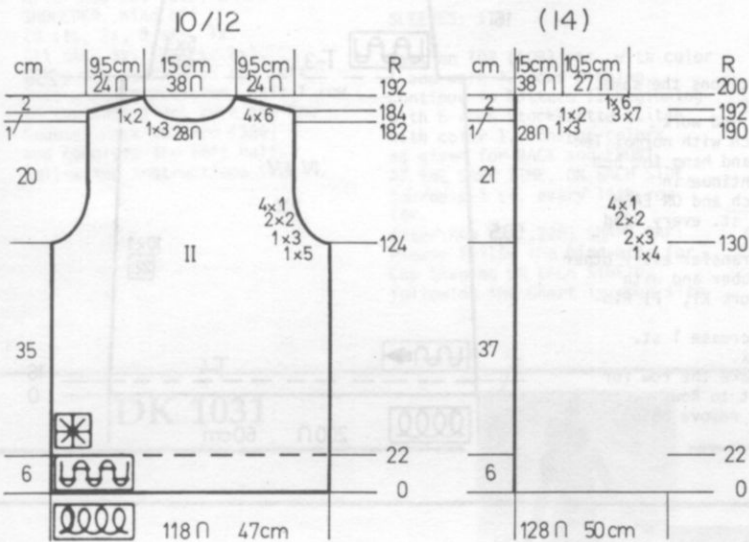
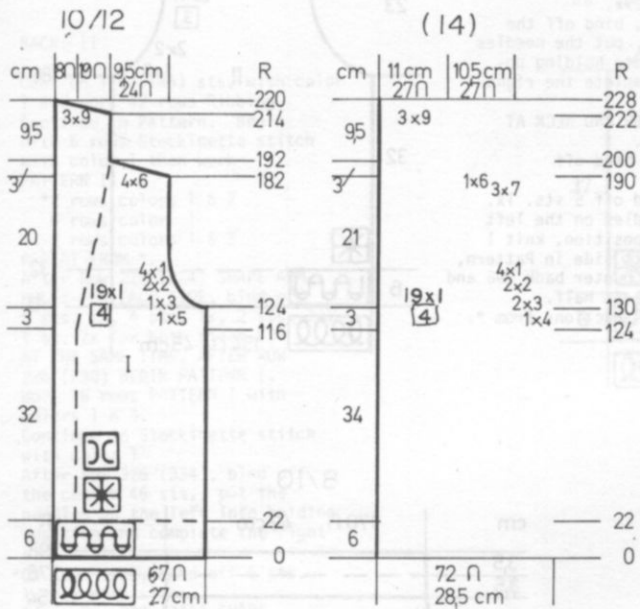

BACK: II

Cast on 118 (128) sts. and work 22 rows Ribbing. Continue in Pattern. After Row 124 (130) SHAPE ARMHOLE: ON EACH SIDE, bind off 5 sts. 1x, 3 sts. 1x, 2 sts. 2x, 1 st. 4x. (4 sts. 1x, 3 sts. 2x, 2 sts. 2x, 1 st. 4x). After Row 182 (190), bind off the center 28 sts., put the needles on the left into holding position and complete the right side first. WATCH FOR SHOULDER SHAPING. \*ON NECK SIDE, bind off 3 sts. 1x, 2 sts. 1x for both sizes. After Row 184 (192) SHAPE SHOULDER. Bind off 6 sts. 4x. (7 sts. 3x, 6 sts. 1x). Bring the needles on the left into working position, knit 1 row in Pattern to the left side, turn the Row Counter back to 184 (192) and complete the left half. Follow the instructions from \*

SLEEVES: III

Cast on 78 (82) sts. and work 10 rows Ribbing. Continue in Pattern. ON EACH SIDE, increase 1 st. every 8th row 4x. After Row 44 (48) SHAPE CAP. Please follow the Cap Shaping on each side as shown on the Chart for your size.

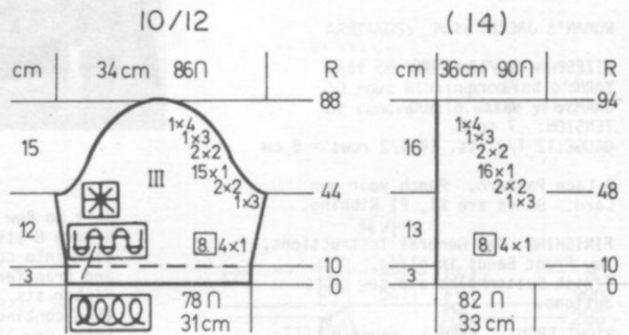

# HP 1033



## MAN'S SLEEVELESS PULLOVER

**SIZES:** Small Medium  
**YARN:** Amore  
**GRAMS:**  
 color 1 200 250  
 color 2 100 100  
 color 3 50 50  
 color 4 50 50  
**TENSION:** 6 to 8  
**GAUGE:** 13 sts. 16 rows = 5 cm (2")

A Fairisle (Norwegian) Design.  
 Punch your own Cards.  
 Bands are K1, P1 Ribbing.

**FINISHING:** See General Instructions

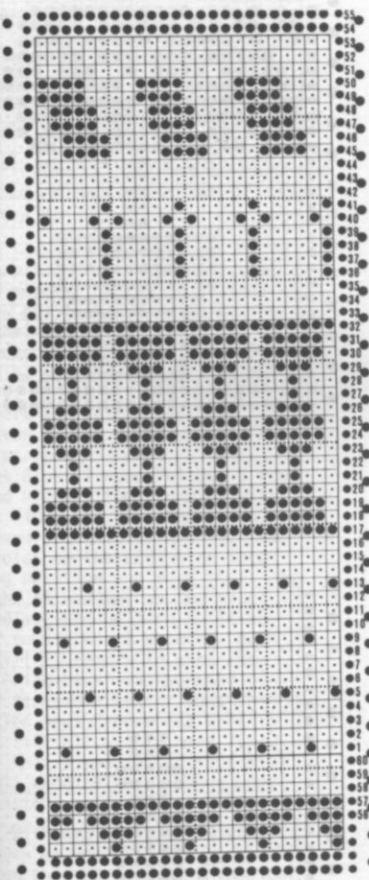

BEGIN HERE

ROWS	COLORS
3	2 & 3
1	3
3	1
1	1 & 4
3	1
1	1 & 4
3	1
1	1 & 3
3	1
1	1 & 3
3	1
1	1 & 3
4	3 & 4
3	3 & 2
3	1 & 2
4	1 & 4
1	4
3	2
6	2 & 1
3	2
6	1 & 3
3	1

REPEAT FROM BEGINNING

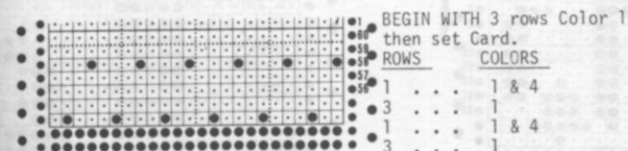

REPEAT THE PUNCH CARD THROUGH ROW 38, THEN PUNCH 2 ROWS OF HOLES - ROWS 42 AND 43 FOR CONNECTING CARD.

REPEAT FROM BEGINNING.

**ARMBANDS:** Make 2.

Cast on 148 sts. with color 1 and work K1, P1 Ribbing. ON EACH SIDE, decrease 1 st. every 2nd row 4x. After Row 12, bind off or remove onto contrast waste yarn.

**NECKBAND:**

Cast on 200 sts. with color 1 and work K1, P1 Ribbing. ON EACH SIDE, decrease 1 st. every 2nd row 5x. After Row 12, bind off or remove onto contrast waste yarn.

**BACK: II**

Cast on 136 (144) sts. with color 1 and work 28 rows Ribbing. Continue in Pattern I. Knit to Row 140 (144). SHAPE ARMHOLE: ON EACH SIDE, bind off 6 sts. 1x, 5 sts. 1x, 4 sts. 1x, 3 sts. 1x, 2 sts. 1x, 1 st. 3x. (6 sts. 1x, 5 sts. 1x, 4 sts. 1x, 3 sts. 1x, 2 sts. 1x, 1 st. 4x). At Row 152 you will have repeated Pattern 1x more. Work 4 more rows of Pattern, then 3 rows Stockinette stitch with color 1 and CONTINUE with PATTERN II.

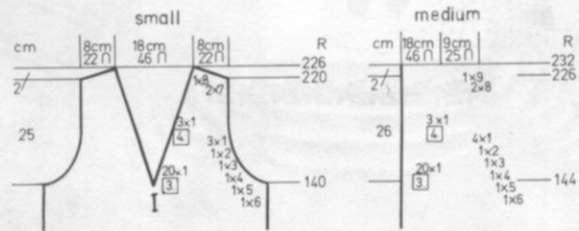

**FRONT: I**

Work the front the same as the back to Row 140 (144). Divide in the center. Put the needles on the left into holding position and complete the right side first. \*SHAPE ARMHOLE same as the back and ON NECK SIDE, decrease 1 st. every 3rd row 20x, every 4th row 3x for both sizes and REMEMBER TO CHANGE PATTERNS AT ROW 159. After Row 220 (225), SHAPE SHOULDER same as the back. Bring the needles on the left into working position, knit 1 row in Pattern to the left side, turn the Row Counter back to 140 (144) and complete the left half. Follow the instructions from \*.

After Row 220 (226), bind off the center 36 sts., put the needles on the left into holding position and complete the right side first. \*SHAPE SHOULDER AND NECK AT THE SAME TIME. FOR SHOULDER, bind off 7 sts. 2x, 8 sts. 1x. (8 sts. 2x, 9 sts. 1x). FOR NECK, bind off 3 sts. 1x, 2 sts. 1x for both sizes. Bring the needles on the left into working position, knit 1 row in Pattern to the left side, turn the Row Counter back to 220 (226) and complete the left half. Follow the instructions from \*.

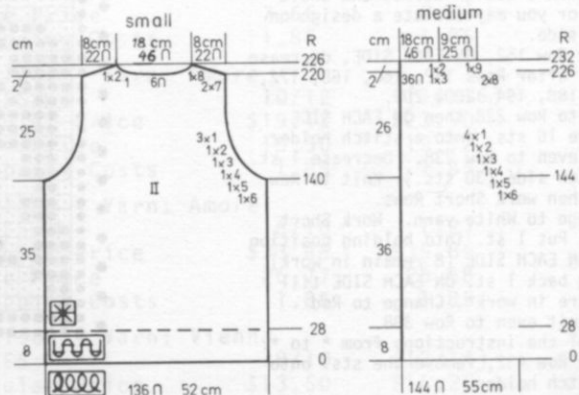

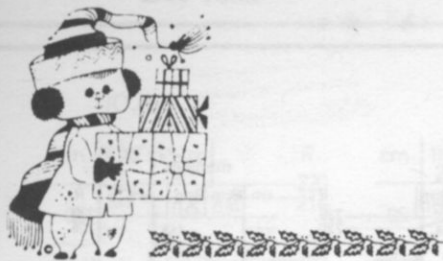

Here is a Stocking and a Child's Toy for your Christmas knitting. Use one or two of the Punch Cards given or any Christmas Punch Cards you own for the designs in the Stocking.

**CHRISTMAS STOCKING:**

**YARN:** Any Sport weight yarn or you can use our Euro Sport Yarn.

**GRAMS:** 100 grams Red or Green  
Small amounts of white and green (red) for Design.

**TENSION:** 7 to 9

**GAUGE:** 14 sts. 19 rows = 5 cm (2")

**FINISHING:** Weave the leg seam 1 st. in from each edge, being sure to catch the open stitch on each side at the heel end. Weave the open sts. of the heel to the leg section. Make a cord over 3 needles with tension 3 and knit 100 rows. Fold cord in half and sew to the inside at top of Stocking.

**NOTE:** Because the Stocking is knitted from the top down, be sure to put the Punch Cards in upside down. USE AUTOMATIC SHORT ROWS FOR HEEL AND TOE SHAPING.

Cast on 82 sts. with red. Knit to Row 42, then begin the color stripes and Pattern.

Knit 4 rows White, 2 rows Red, 4 rows white, 2 rows red, 18 rows of any border pattern, 2 rows Red, 4 rows White, 2 rows Red, 4 rows White. After Row 84, hang the hem.

Turn the tension up 1 number when knitting the hem row, then back to original tension. Continue with Red and decide where you want your design on the leg section. You may work a design across the whole leg, or you may isolate a design on each side.

After Row 152, ON EACH SIDE, decrease 1 st. after Rows 152, 160, 168, 172, 182, 188, 194, 200, 206.

Knit to Row 228 then ON EACH SIDE, remove 16 sts. onto a stitch holder. Knit even to Row 238. Decrease 1 st. on each side (30 sts.). Knit to Row 286 then work Short Rows.

\*Change to White yarn. Work Short Rows. Put 1 st. into holding position 11x ON EACH SIDE (8 remain in work). Bring back 1 st. ON EACH SIDE till all are in work\*. Change to Red and knit even to Row 388.

REPEAT the instructions from \* to \*. After Row 432, remove the sts. onto a stitch holder.

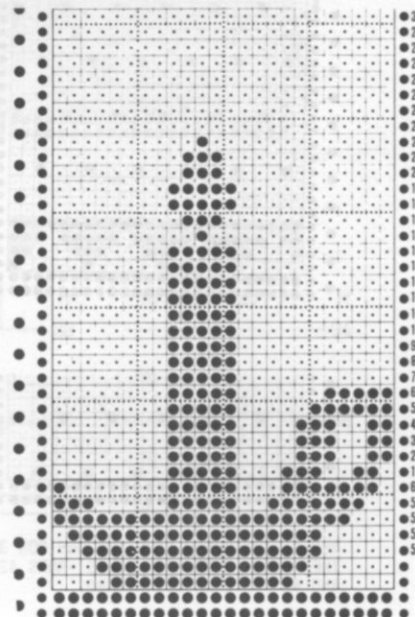
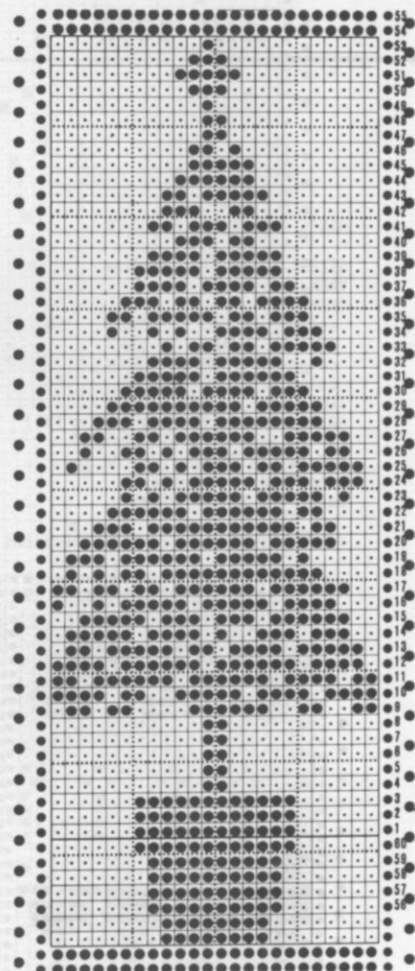
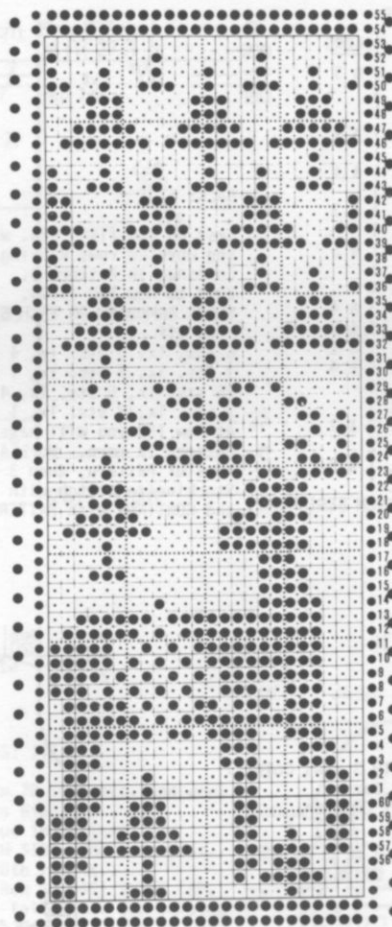

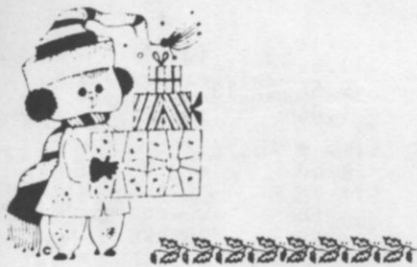

**ARMS:** With Blue, cast on 22 sts. and work color stripes \*2 rows Blue, 2 rows Yellow, 2 rows Red and REPEAT from \* ending with 2 rows Blue (Row 56). Change to Pink and knit even to Row 64. Put 11 needles on the LEFT into holding position and work short rows over the 11 on the right. Put 1 needle into holding position 3x ON EACH SIDE, then bring them back 3x ON EACH SIDE. Bring all the needles into working position and remove onto waste yarn. Work the 2nd arm with reverse shaping.

**HAT:** With Blue, cast on 73 sts. Knit 10 rows then hang the hem. Work color stripes \*2 rows Red, 2 rows Yellow, 2 rows Blue and REPEAT to Row 30. Change to Red and knit 2 rows. ON EACH SIDE, decrease 1 st. every 2nd row to Row 44, then ON EACH SIDE, decrease 1 st. EVERY ROW to row 74. Bind off 3 sts.

**HUMPTY CLAUS**

**YARN:** Any Sport weight yarn or you can use our Euro Sport.

**GRAMS:** 100 grams Red  
50 grams each of of  
Pink, Blue, Yellow.  
(150 grams of Red plus the same amounts of the other colors will make 2 toys).

**FINISHING:** Weave all the sts. together that are held on contrast waste yarn and remove the waste yarn. Weave body seams leaving an opening for stuffing. Stuff and close opening. Weave leg and arm seams then stuff and close top openings. Weave back seam of hat. Cut oval eyes from black felt and blind stitch onto face. Embroider Mouth. Sew arms and legs in place. (See Picture). Sew hat to head and make pom on out of scraps of color then sew to tip of hat.

**BODY & FACE:** With Red, cast on 90 sts. Knit 1 row to the left side. Put 45 needles on the right side into holding position and work short rows over the 45 needles on the left. Put 2 needles into holding position beginning next 17 rows (11 remain in work. Bring all the needles into work and knit 1 row. Knit even to Row 50 then begin the color stripes.

\*2 rows Blue, 2 rows Yellow, 2 rows Red and REPEAT from \* ending with 2 rows Blue (Row 76) Change to Pink yarn and knit to Row 94. Put 45 needles on the LEFT side into holding position and work short rows over the 45 needles on the right. \*1 needles into holding position next 2 rows, then 2 needles each side till 13 remain in work (Row 116). Bring back into working position \*1 needle next 2 rows then 2 needles next 2 rows and REPEAT from \* till all are in work. (Row 138). Knit 1 row to the left side over all needles then remove work onto waste yarn.

**LEGS:** With red, cast on 22 sts. Knit even to Row 66. Change to Blue and knit 10 rows even then put 11 sts. on the left side into holding position and work short rows over the 11 needles on the right as you did before. \*Put 1 needle into holding position 4 x on each side. Bring back into work work, 1 needle till all are in work\*. Knit 4 rows even then REPEAT the short rows from \* to \*. After Row 112, bring all the needles into working position and remove the sts. onto waste yarn.

Knit the 2nd leg section with reverse shaping.

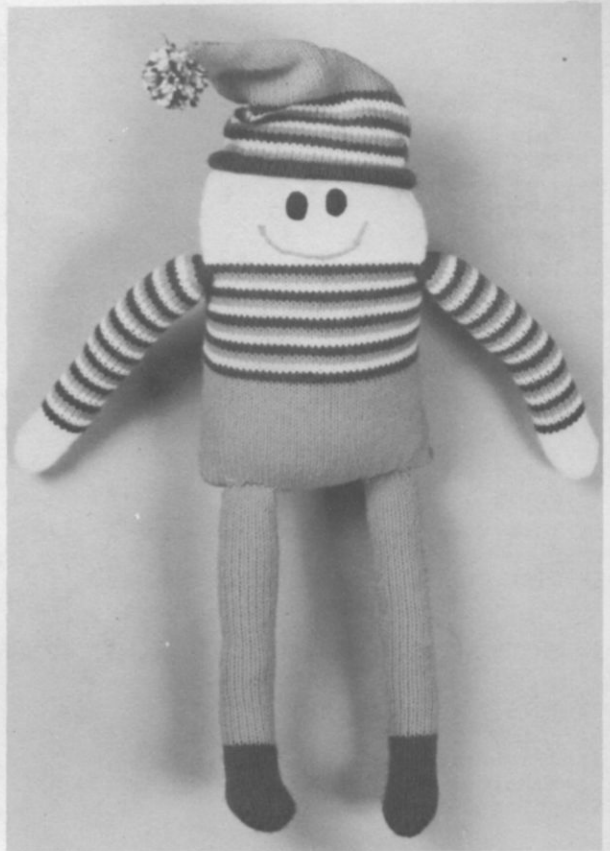

# KNITTING NEWS

YARN KITS FOR THIS ISSUE OF KNITTING MAGAZINE

Be sure to take advantage of the specially discounted prices on Yarn Kits for the garments in this issue of KNITTING MAGAZINE. Please remember that the special discounts are for subscribers only and are good until the next issue of the Magazine. Be sure to give alternate colors.

DISCOUNTS ON YARN KITS FOR THIS ISSUE

DK 1006 - Yarn: Amore			
SIZES:	8/10	(12)	
Regular Price	\$9.56	\$11.95	
Sale Price	7.65	9.56	
Shipping Costs	1.85	1.85	
DK 1007 - Yarn: Amore			
SIZES:	10/12	(14/16)	
Regular Price	\$19.12	\$23.90	
Sale Price	15.30	19.12	
Shipping Costs	1.85	1.85	
DK 1008 - Yarn: Amore			
SIZES:	8/10	(12)	
Regular Price	\$33.46	\$35.85	
Sale Price	26.77	28.68	
Shipping Costs	1.85	1.85	
DK 1009 - Yarn: Vienna			
SIZES:	8/10	(12/14)	
Regular Price	\$13.50	\$16.20	
Sale Price	10.80	12.96	
Shipping Costs	1.85	1.85	

HP 1010 - Yarn: Fortissima  
 SIZES: 36/38 (40)  
 Regular Price \$20.64 \$25.80  
 Sale Price 16.51 20.64  
 Shipping Costs 1.85 1.85

DK 1011 - Yarn: Amore  
 SIZES: 7/8 (10/12) [14]  
 Regular Price \$ 9.56 \$11.95 \$14.34  
 Sale Price 7.65 9.56 11.47  
 Shipping Costs 1.85 1.85 1.85

DK 1012 - Yarn: Amore  
 SIZES: 7/8 (10/12)  
 Regular Price \$28.68 \$33.46  
 Sale Price 22.94 26.77  
 Shipping Costs 1.85 1.85

DK 1013 - Yarn: Vienna  
 SIZES: 8/10 (12)  
 Regular Price \$13.50 \$16.20  
 Sale Price 10.80 12.96  
 Shipping Costs 1.85 1.85

DK 1014 - Yarn: Antille (See Note at end of list).  
 SIZE: 12/14  
 SPECIAL PRICE 79¢ per ounce.  
 1 Cone - Cones are approximately 1 1/2 lbs. to 2 lbs.  
 Shipping - \$2.50 for first Cone - \$1.00 each additional Cone.

DK 1015 - Yarn: Vienna  
 SIZES: 10/12 (14)  
 Regular Price \$37.80 \$37.80  
 Sale Price 30.24 30.24  
 Shipping Costs 1.85 1.85

KK 1016 - Yarn: Vienna  
 SIZES: 8/10  
 Regular Price \$21.60  
 Sale Price 17.28  
 Shipping Costs 1.85

KK 1017 - Yarn: Amore  
 SIZES: 3/4 (5/6)  
 Regular Price \$23.90 \$23.90  
 Sale Price 19.12 19.12  
 Shipping Costs 1.85 1.85

KK 1018 - Yarn: Amore  
 SIZES: 4/5 (6/7)  
 Regular Price \$14.34 \$16.73  
 Sale Price 11.47 13.38  
 Shipping Costs 1.85 1.85

KK 1019 - Yarn: Amore  
 SIZES: 6/7 (8/10)  
 Regular Price \$14.34 \$16.73  
 Sale Price 11.47 13.38  
 Shipping Costs 1.85 1.85

KK 1020 - Yarn: Amore  
 SIZES: 2/3 (4)  
 Regular Price \$7.17 \$7.17  
 Sale Price 5.74 5.74  
 Shipping Costs 1.85 1.85

KK 1021 - Yarn: Amore  
 SIZES: 2/3 (4)  
 Regular Price \$7.17 \$7.17  
 Sale Price 5.74 5.74  
 Shipping Costs 1.85 1.85

DK 1022 - Yarn: Vienna & Capriccio (Cover Model)  
 SIZES: 8/10 (12/14)  
 Regular Price \$46.40 \$51.81  
 Sale Price 37.12 41.44  
 Shipping Costs 1.85 1.85

DK 1023 - Yarn: Amore  
 SIZES: 10/12 (14/16)  
 Regular Price \$11.95 \$14.34  
 Sale Price 9.56 11.47  
 Shipping Costs 1.85 1.85

DK 1024 - Yarn: Amore  
 SIZES: 8/10 (12/14)  
 Regular Price \$11.95 \$16.73  
 Sale Price 9.56 13.38  
 Shipping Costs 1.85 1.85

HP 1025 - Yarn: Fortissima & Amore  
 SIZES: 38/40  
 Regular Price \$37.70  
 Sale Price 30.16  
 Shipping Costs 1.85

DK 1026 - Any Yarn to give Stitch and Row Gauge.  
 No Kit Available.  
 SIZES: 10/12 (14)

HP 1027 - Yarn: Fortissima & Vienna  
 SIZES: 38/40 (42)  
 Regular Price \$34.14 \$36.72  
 Sale Price 27.31 29.38  
 Shipping Costs 1.85 1.85

DK 1028 - Yarn: Amore  
 SIZES: 8/10 (12/14)  
 Regular Price \$19.12 \$21.51  
 Sale Price 15.30 17.21  
 Shipping Costs 1.85 1.85

DK 1029 - Yarn: Amore  
 SIZES: 10/12 (14)  
 Regular Price \$21.51 \$23.90  
 Sale Price 17.21 19.12  
 Shipping Costs 1.85 1.85

HP 1030 - Yarn: Vienna  
 SIZES: 36/38 (40)  
 Regular Price \$40.50 \$43.20  
 Sale Price 32.40 34.56  
 Shipping Costs 1.85 1.85

DK 1031 - Yarn: Amore  
 SIZE: 8/10  
 Regular Price \$28.68  
 Sale Price 22.94  
 Shipping Costs 1.85

DK 1032 - Yarn: Amore  
 SIZES: 10/12 (14)  
 Regular Price \$19.12 \$21.51  
 Sale Price 15.30 17.21  
 Shipping Costs 1.85 1.85

DK 1033 - Yarn: Amore  
 SIZES: Small (Medium)  
 Regular Price \$19.12 \$21.51  
 Sale Price 15.30 17.21  
 Shipping Costs 1.85 1.85

CHOOSE YOUR YARN KITS FOR THE FOLLOWING COLORS

VIENNA ... White, Yellow, Rdd, Gold, Navy, Lt. Green, Peach, Lilan, Beige, Med. Blue, Dk. Green, Plum, Brown, Bottle Green, Sea Foam, Aqua.

AMORE ... Med. Blue, Lt. Grey, Dk. Grey, Red, Beige, Navy, Pink, Black, White, Turq. Yellow, Dk. Green, Hot Pink, Lilac, Rose Tweed, Plum, Jade, Brown, Rust, Strawberry, Orange Tweed, Burgundy, Sky Blue, Coral.

NOTE: - The Dress DK 1014 shows it to be made in a plain dress yarn. We made it in out ANTILLE which is a mixture of Acrylic and Linen (space dyed) and it is absolutely gorgeous. We priced the yarn at 79¢ per ounce (a fantastic bargain) and the Cones weigh between 1 1/2 lbs. to 2 lbs. We will make the adjustment up or down as necessary when you place your order.



DK 1024

HP 1025

DK 1015







KK 1016



DK 1011

DK 1012



**DK 1028**

**DK 1029**

**HP 1030**





HP 1027

DK 1026

KK 1019

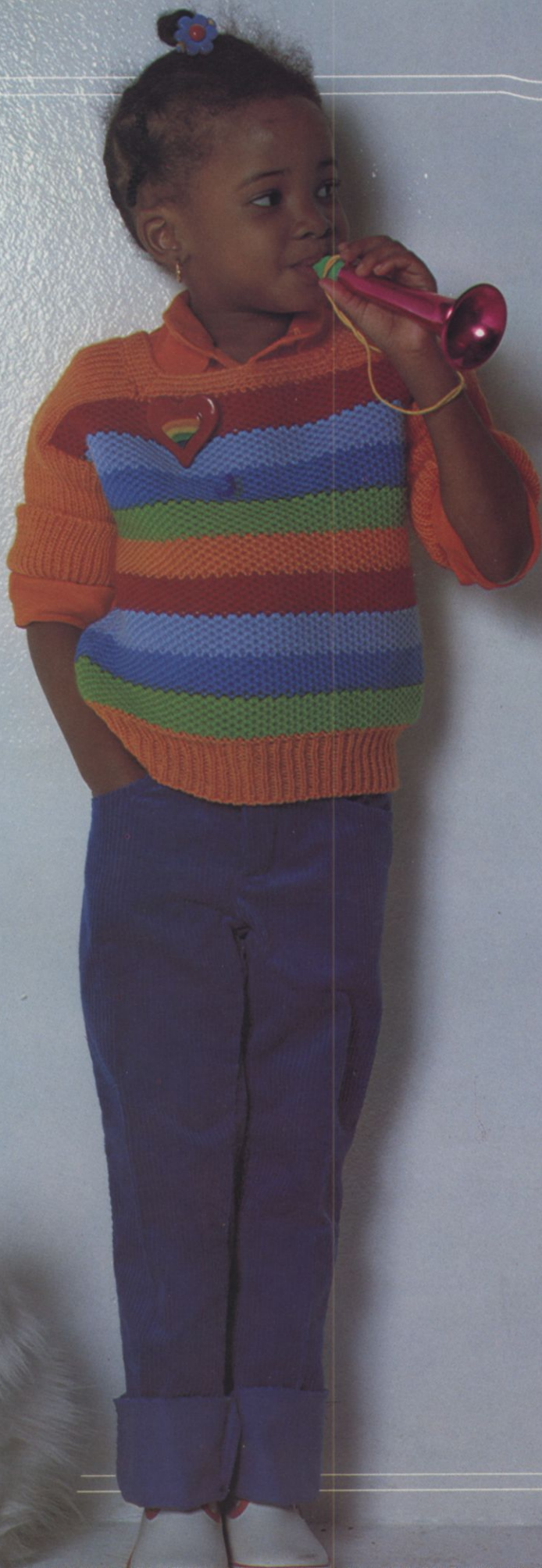

KK 1020

KK 1021

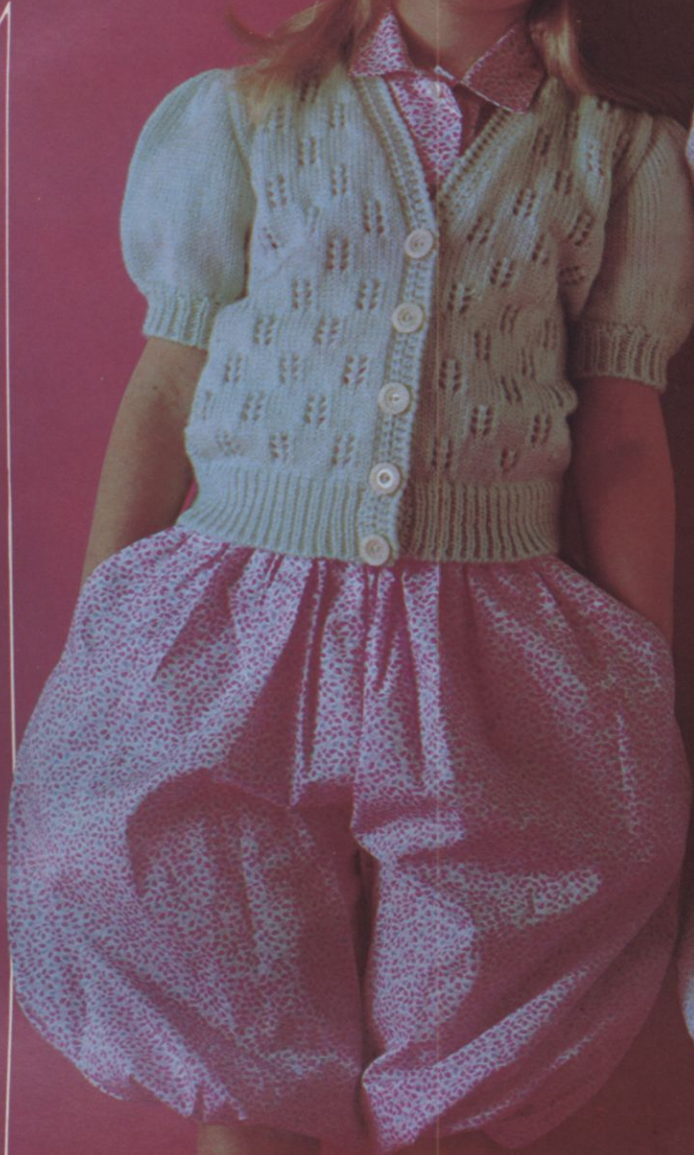



KK 1017

KK 1018