

knitking

magazine





DK 408



DK 407

DK 409



DK 417



DK 420

HP 406



DK 405

A woman with blonde hair is shown from the waist up, leaning on a wooden log. She is wearing a red knit beanie with a black zigzag pattern and a matching red knit cardigan with black zigzag patterns and white horizontal stripes. Underneath, she wears a white turtleneck sweater. She is holding a yellow apple to her mouth and taking a bite. The background is a blurred green field. The entire image is framed by a thick yellow border with decorative scrollwork at the corners, set against a black background.

DK 399

DK 396



A woman with reddish-brown hair is sitting on a wooden fence in a grassy field. She is wearing a light-colored beret, a white turtleneck, a patterned poncho with brown and white geometric designs and fringed edges, white leggings, and brown boots. She is holding a long, thin stick or branch. The background shows green foliage and a clear sky. The entire image is framed by a decorative yellow and green border.

DK 404

DK 421



DK 418

VOLUME 13, NO. 1

knitking magazine

TABLE OF CONTENTS	PAGE NO.
HP 393 Man's Pullover	14
HP 394 Man's Jacket	15
HP 395 Teen Boy's Pullover	16
DK 396 Woman's Jacket	17
DK 397 Woman's Suit	18
KK 398 Child's Hooded Jacket	22
DK 399 Woman's Jacket & Hat	23
KK 400 Boy's Pullover	25
HP 402 Men's Long Johns & Shirt	26
KK 403 Girl's Skirt, Pullover & Tabard	27
DK 404 Woman's Poncho	29
DK 405 Woman's Pullover	30
HP 406 Man's Pullover	30
DK 407 Woman's Skirt	32
DK 408 Woman's Jacket	32
DK 409 Woman's Pullover	33
DK 410 Woman's Long Skirt	35
DK 411 Woman's Blouse	34
DK 414 Woman's Dress	36
DK 415 Woman's Pants	37
DK 416 Woman's Hat & Mittens	37
DK 417 Woman's Coat	38
DK 418 Woman's Pullover	39
DK 419 Woman's Long John Suit	40
DK 420 Woman's Cape	41
DK 421 Woman's Boot Pants	42
Socks for Everybody	Inside Back Cover

Publisher: KNITKING CORPORATION, 1128 Crenshaw Blvd., Los Angeles, Calif. 90019. Telephone: (213) 938-2079. Published bi-monthly. Subscriptions: USA — \$10.00 annually, single copies \$3.00; Canada — \$12.00; other parts of the world — \$15.00. The entire contents of KNITKING MAGAZINE are copyright and must not be reproduced in any shape or form without the express permission, in writing of the publisher. © COPYRIGHT 1976 by KNITKING CORPORATION.

editorial

This issue marks the start of our Thirteenth year of publication and we are happy that the majority of our Charter Subscribers is still with us... We are proud of the fact that although KNITKING MAGAZINE has always operated at a loss financially, we continue in our endeavor to offer only the best in styles and presentation... KNITKING is a full service organization and KNITKING MAGAZINE is an integral part of that service.

We, sometimes, have magazine production problems that are difficult to overcome and that cause lengthy delays... We gain time on some issues only to lose it again on others. As a consequence, we receive many letter complaining about late deliveries... This issue, for example, should be marked NOVEMBER/DECEMBER, but as we cannot go to press until the end of December, such marking seems rather ridiculous... We, nevertheless, did produce 6 issues in 1976. We expect to produce 6 issues in 1977 and in the following years, but instead of marking them in months, we will mark them by Volume. This issue is Volume 13, No. 1 and you will find it so marked above the Contents column on this page. Our next issue will be Volume 13, No. 2. It is being prepared now and promises to be an outstanding issue full of attractive garments. For Women, we have a variety of stylish coats and sweater coats... full length, middy and fingertip. Some suits, dresses, a tunic a glamorous evening gown and many more... For Men, a trio of sweaters and cardigans in excellent taste and for the boys and girls, some charming garments (including two in true Bavarian style), that will be irresistible to loving parents and grandparents.





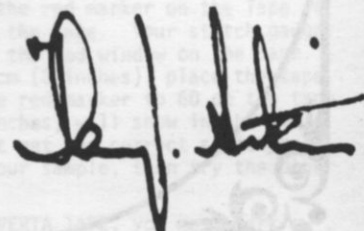









North American readers will receive a brochure in this issue of KNITKING MAGAZINE with information regarding the KNITKING WARDROBE PLAN... A completely new and revolutionary concept in service to the machine knitter... It is KNITKING'S ambition to make knitting by machine as popular in the U.S.A. as sewing by machine... We aim to make a knitting machine as important to a complete home as is a sewing machine and we intend to simplify machine knitting to the point where every member of the family will have a wardrobe of handsome knitted garments made at absolute minimum costs.









KNITKING is planning many things for 1977... Stick with us for everything that is best in machines, patterns, yarn and services... We wish all of you a successful and happy year in 1977.























Pattern Symbols

Knitting – Chart Symbols

- () Size Symbols (2nd Size)
- < > 3rd Size
- B** Beginners Pattern
- T** Tension
- G** Gauge
- ① Color Number
-  Cast on
- n** Stitch
- R** Row
- H** Hem
-  Bind off
-  Stockinette stitch – worn on the Knit side.
-  Stockinette stitch – worn on the Purl side.
-  Knit 1, Purl 1 Ribbing
-  Ribbing Pattern – worn on the Knit side.
-  Ribbing Pattern – worn on the Purl side.
-  Closed Dart
-  Open Dart
-  Put on a stitch holder
-  Reverse 1 section
-  On every other needle
-  Number of Rows between Shapings. Make increase (or decrease) FIRST, then knit 4 rows. For example: 3 x 1  means decrease (or increase) 1 st., knit 4 rows; decrease 1 st., knit 4 rows; decrease 1 st., knit 4 rows; decrease 1 st., knit 4 rows. All decreasing (or increasing) without row numbers as shown must be shaped on every 2nd row.

-  Increase
 -  Increase 2 sts. With a transfer tool, move the sts. over the left (or right) leaving 2 empty needles at the point of increase. At the increase point, move 1 st. to the left, (or right) so that there is an empty needles on each side of a stitch. On each side of the center stitch, pick up a stitch from the row below and hang it onto the empty needle.
 -  3 stitches on 1 needle. The 1st and 3rd stitch in a group of 3 has been hung on the 2nd or center needle.
 -  Short Row increase or decrease; for instance on a flared skirt knitted sideways.
 -  Pattern Stitch
 -  Pattern Stitch – worn on the Knit side.
 -  Pattern Stitch – worn on the Purl side.
 -  Norwegian Design using the Pattern Reader. Only 1 row must be registered on the Pattern Reader, so when knitting two or more colors in 1 row, knit the first color with the LEVER of Pattern Reader UP (working), then push the LEVER DOWN (non-working) for the additional colors.
REPEAT the above for each complete row.
 -  Repeat
- I = Front
 - II = Back
 - III = Sleeve
 - IV = Skirt Front
 - V = Skirt Back
 - VI = Collar
 - VII = Pocket
 - VIII = Band
 - IX = Belt
 - X = Cuff
 - XI = Pants Front
 - XII = Pants Back

Finishing – Chart Symbols

-  Match numbers on section for assembling.
 -  Ease
 -  Fold Line
 -  Turn to the wrong side and hem.
- ### Stitch Symbols
-  Knit Stitch
 -  Purl Stitch
 -  Needles in holding position
 -  Needles back into working position.
 -  Empty needle (leave in working position)
 -  Needle not used (in the out of work position).
 -  Two stitches on 1 needle, either transferred from the right side or the left side, then put into holding position.
 -  Needle holding 2 stitches. Stitch has been transferred from the RIGHT.
 -  Needle holding 2 stitches. Stitch has been transferred from the LEFT.
 -  Center of garment section
 -  Pattern Reader
 -  JAC 40
 -  Adjustable Needle Selector
 -  Pattern Wheel
 -  Weaver
 -  Needle Shifter

General Instructions

HOW TO READ THE CHARTS AND INSTRUCTIONS

There are 3 sizes given for each Pattern in KNITTING MAGAZINE. Above each Chart for the different sizes, you will see that the first and smaller sizes might be shown as 8/10, the second size as (12/14) and the third as [16/18]. Check the measurements at the bustline and hips on the Charts to be certain that you will knit the correct size, remembering these are ACTUAL measurements of the completed section and that there must be a bigger allowance at the bustline and hipline for a Jacket or a Coat than there would be for a fitted dress or a fitted blouse or pullover. The question in your mind should be "How do I want this garment to fit...?"

When you have chosen the size you need, you can follow the Charts as shown. You will notice that where the shapings are the same FOR ALL SIZES, only 1 set of shapings will be shown on the first Chart and if you are knitting the 2nd or 3rd size, you simply follow the shapings as given for the first size. If the shapings are different, this will be shown on the Charts and you should follow them as given.

On the Charts, increases and decreases will be shown as follows

5×1
6 The number in the box means number of ROWS between the shapings, while the 5×1 above the box means - 1 st. $5 \times \dots$ so you will increase or decrease 1 st. every 6th row $5 \times$.

ARMHOLE SHAPINGS - NECK SHAPINGS - SHOULDER SHAPINGS - are made on every 2nd row UNLESS there is a number in a box along side or below the shapings. The rule is... where there is no box with a number, the shaping is made on every 2nd row.

THE PRINTED INSTRUCTIONS

You can follow the printed instructions or use them in combination with the Charts. Where there is any question in the printed instructions, you have the Charts to show you how the section will look.

The 3 sizes, with the different amounts of cast on stitches and the different shapings will look like this...

Cast on 124 (136) [148] sts. You will
Cast on 124 sts. for the first size.
Cast on 136 sts. for the 2nd size.
Cast on 148 sts. for the 3rd size.

The important thing to remember is that you MUST READ AHEAD so that you KNOW what to do for the size you are knitting. Sometimes where the number of stitches are the same but the number of times different, you will find shapings like this...
 $3 \text{ sts. } 1 \times (2 \times) [3 \times], 2 \text{ sts. } 1 \times (2 \times) [3 \times], 1 \text{ st. } 3 \times (4 \times) [5 \times]$.
As you see, you MUST read ahead in order to follow the instructions as given for YOUR SIZE. The rows will be different for the different sizes in some cases... Shoulder and Neck shapings usually are worked at the SAME TIME for the back section - so watch for the words AT THE SAME TIME.

HOLDING STITCHES ON THE LEFT SIDE WHILE SHAPING THE RIGHT SIDE

When knitting a section of garment in stockinette stitch, it is easy to hold the stitches on the left side while knitting the right half, but when knitting a Pattern Stitch such as a Norwegian Design, a Holding Position Design, Weaving, etc., you should use the following method. For the NECK SHAPING, we tell you to bind off the center sts., put the needles on the left into holding position and complete the right half first... so with a strand of contrast yarn, knit ALL of the left side stitches manually by hand, pulling each stitch back against the needle bed to the OUT OF WORK position. When the right side is completed, carefully pull the stitches held on contrast, forward into working position and as you do so, undo the contrast yarn, line up the needles (KNITTING machine owners, put the stitches under the sinkers) and complete the left half.

If you own a Japanese machine, you may find that when knitting the right half with the left side held in this way, the sinker plate will mark the left side while you are knitting the right half. To prevent this marking, you can tape a piece of paper over the knitting, underneath the sinkers, or if you own a Reversing Bar, you can hang this onto the Sinkers while you are knitting the right half. When hanging the Reversing Bar, be sure the eyes of the bar go BETWEEN the Sinker Posts on the upper part of the bar so that the tips of the bar only - show above the needle bed.

FULL FASHION DECREASING OR INCREASING

For Stockinette stitch, always use the Full Fashion method for increasing or decreasing.

TO DECREASE: Hang the 3rd stitch onto the 2nd stitch then move the stitches in to fill the empty needle.

TO INCREASE: Move the 2 end stitches 1 needle outward, then pick up the 3rd stitch from the row below and hang it onto the empty needle.

NORWEGIAN DESIGNS:

In the instructions, each row of the Norwegian Design is counted as 1 row but several movements of the Cam Box (or Slide) are needed to complete 1 row.

NORWEGIAN DESIGN WHEN USING THE PATTERN READER

When you use the Pattern Reader and knit a Norwegian Design using several colors, it is necessary to move the Trip Control Lever so that only 1 row registers.

FINISHING: Block all sections. For PULLOVERS, JACKETS, and DRESSES: Join front to back at sides and shoulders. Sew sleeves together and set in. Hem lower edge and sleeve edges if needed. For a double neckband or armhole band, sew 1 edge to the inside and 1 to the outside of neck or armhole. For a single ribbed band, sew 1 edge to the outside of neck or armhole edge. For a cardigan or jacket with buttonholes, finish buttonholes and sew on buttons.

PANTS: Join front to back at sides. Sew inside leg seams, then join center front and back. Make hem at waistline and insert elastic. Hem lower edge of pants legs.

THE SAMPLE SWATCH

Before you begin to knit any garment, you will need to knit a sample piece using the yarn you have chosen for your garment, so that you can check the stitch and row gauge which must measure the correct number of stitches and rows in 5 cm (2 inches).

For each Pattern in KNITTING MAGAZINE, we give you 3 tension numbers to work from and if you use the specified yarn for the garment, you should be able to get the correct stitch and row gauge using one of these numbers. Here is a very easy way to make your sample swatch and count the stitches and rows without actually counting, by using our KNITTING Converta Tape.

Supposing the Tension Numbers for the Stitch and Row Gauge are given as 5 to 7. Set the Tension Dial to the first number which is 5. With contrast waste yarn, and using the quick cast on method, cast on 60 stitches and knit 10 rows. Change to garment yarn and turn the Row Counter to 0. Knit 30 rows. Counting from each end, knit the 10th stitch on each side by hand with a small piece of contrast yarn. Leave the needles in working position and knit 30 rows (Row 60), then knit 4 rows with contrast waste yarn. Turn the Row Counter to 0 and the Tension Dial to 6 and with garment yarn, knit 30 rows. Mark the 10th stitch on each side as you did before, knit 30 rows, then 4 rows with contrast waste yarn. Turn the Row Counter to 0 and with Tension 7, repeat the above once more, ending with 10 rows of contrast waste yarn. Remove the work from the machine by passing the Slide across the needles without yarn (sometimes called 'dropping').

Pull and stretch the sample piece both lengthwise and diagonally from corner to corner, then lengthwise again. Do not count the stitches and rows immediately, but allow the sample to rest for several hours or even over night. This will allow the stitches and rows to return to their basic form.

When your sample has rested and you are ready to count the stitches and rows, the KNITTING CONVERTA TAPE will do the counting for you without any counting on your part.

Use the Tape as follows:

To measure the stitches, pull out the Tape to measure BETWEEN the 40 stitches in the center that you marked by hand knitting with contrast waste yarn - Push the red marker on the Tape so that it points to 40 stitches on the Tape. Your stitch gauge to 5 cm (2 inches) will shown in the red window on the tape. To find the number of rows in 5 cm (2 inches), place the tape to measure over 60 rows, push the red marker to 60 on the tape and your row gauge for 5 cm (2 inches) will show in the red window... Easy...? If you do not get the correct stitch and row gauge in the first part of your sample, then try the other two.

If you do not own a KNITTING CONVERTA TAPE, you must mark a 5 cm (2 inch) square in the center of the knitting, then count the number of stitches and rows within the square.

HP 393

MAN'S PULLOVER

SIZES: 38 (40) [42]
YARN: Euro Sport
GRAMS:
 color 1 200 250 300
 color 2 50 50 50
TENSION: 9 or 10
GAUGE: 12 sts. 15 rows = 5 cm (2")

The front section has a small Pattern made by changing the 3 Purl sts. (as they face you) into knit sts. for 4 rows as shown on the Line Drawing (see picture). The knit side is the right side. Bands are K1, P1 Ribbing with color stripes. SEE PRINTED COPY

FINISHING: See General Instructions.

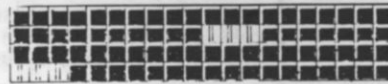

*
 17.-24. R
 13.-16. R
 5.-12. R
 1.-4. R

ARMBANDS: VIII Make 2.

Cast on 120 (125) [125] sts. with color 2 and work 14 rows K1, P1 Ribbing with REPEATED color stripes of 2 rows color 2, 4 rows color 1. After Row 14, remove the sts. onto contrast waste yarn.

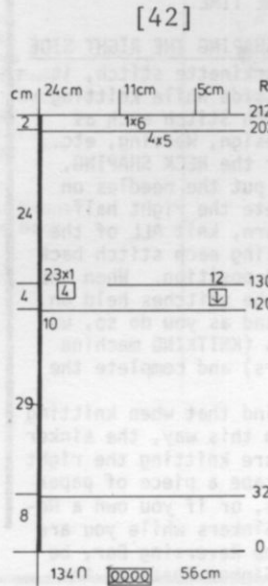
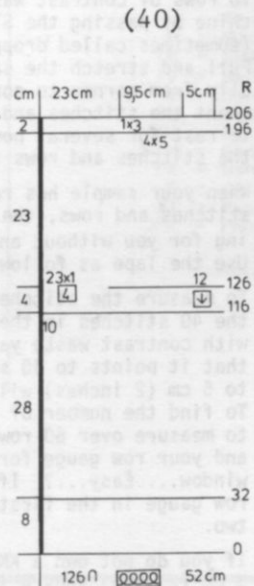
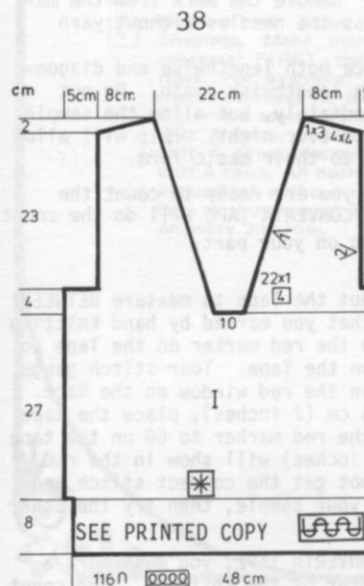
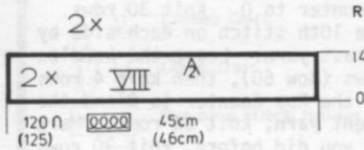

38 (40) [42]

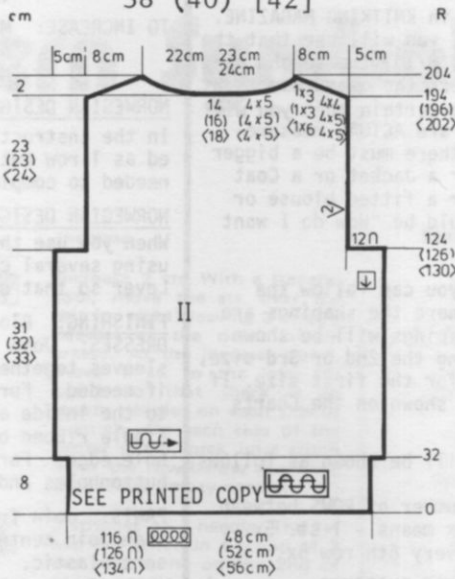

BACK: II

Cast on 116 (126) [134] sts. with color 2 and work 32 rows K1, P1 Ribbing with REPEATED color stripes of 2 rows color 2, 8 rows color 1.

Change to Stockinette stitch and continue with color 1. Knit to Row 124 (126) [130]. Bind off 12 sts. before knitting the next 2 rows, then knit to Row 194 (196) [202].

Bind off the center 14 (16) [18] sts., put the needles on the left into holding position and complete the right side first.

*SHAPE SHOULDER AND NECK AT THE SAME TIME.

FOR SHOULDER, bind off 4 sts. 4x, 3 sts. 1x.

(5 sts. 4x, 3 sts. 1x). [5 sts. 4x, 6 sts. 1x].

FOR NECK, on all sizes, bind off 5 sts. 4x.

Bring the Cam Box to the left side, turn the Row Counter back to 194 (196) [202] and complete the left half. Follow the instructions from *.

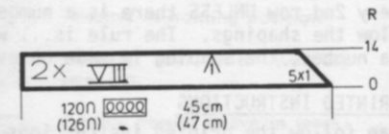

NECKBAND: VIII Make 2.

Cast on 120 (126) [126] sts. with color 2 and work K1, P1 Ribbing with REPEATED color stripes of 2 rows color 2, 4 rows color 1 and AT THE SAME TIME, on the RIGHT (left for 2nd section), on every 2nd row, decrease 1 st. 5x.

After Row 14, remove the sts. onto contrast waste yarn.

FRONT: I

Cast on 116 (126) [134] sts. color 2. Work 32 rows K1, P1 Ribbing with REPEATED color stripes the same as the back.

Continue in Stockinette stitch with Pattern as shown on the Line Drawing. Knit to Row 114 (116) [120].

Bind off the center 10 sts., put the needles on the left into holding position and complete the right side first.

*ON NECK SIDE, decrease 1 st. every 4th row 22x (23x) [23x] and AT THE SAME TIME, after Row 124 (126) [130], bind off 12 sts. for Armhole.

After Row 194 (196) [202], SHAPE SHOULDER: Bind off

4 sts. 4x, 3 sts. 1x.

(5 sts. 4x, 3 sts. 1x). [5 sts. 4x, 6 sts. 1x].

Bring the needles on the left into working position, knit 1 row in Pattern to the left side, turn the Row Counter back to 114 (116) [120] and complete the left half. Follow the instructions from *.

HP 394

MAN'S JACKET

SIZES: 36 (38) [40]
 YARN: Binia
 GRAMS:
 color 1 450 500 550
 color 2 100 100 100
 TENSION: 8 to 10
 GAUGE: 13 sts. 18 rows = 5 cm (2")

Stockinette stitch with ribbed bands and color stripes. The Purl side is the right side. You will need a Jacket type Zipper.

FINISHING: See General Instructions. Sew in zipper.



BACK: II

OPEN CAST ON. With contrast waste yarn, cast on 124 (134) [146] sts. Knit 8 to 10 rows, change to color 1 and put the Row Counter at 60. Work Stockinette stitch with color stripes as shown on the Chart. After Row 164 (170) [176], continue with color 1 and

SHAPE ARMHOLE: ON EACH SIDE, bind off

3 sts. 2x, 2 sts. 2x, 1 st. 3x. (3 sts. 2x, 2 sts. 3x, 1 st. 3x). [4 sts. 1x, 3 sts. 1x, 2 sts. 3x, 1 st. 5x].

Knit to Row 228 (238) [248]. SHAPE SHOULDER, AND AT THE SAME TIME, after Row 232 (242) [252], SHAPE NECK:

FOR SHOULDER, bind off

4 sts. 1x, 5 sts. 5x.

(5 sts. 5x, 6 sts. 1x).

[6 sts. 5x, 3 sts. 1x].

FOR NECK, after Row 232 (242) [252], bind off the center 22 (18) [20]

sts., put the needles on the left into holding position and complete the right side first.

*ON NECK SIDE, bind off

3 sts. 3x.

(4 sts. 3x).

[4 sts. 3x].

Bring the needles on the left into working position, knit 1 row to the left side, turn the Row Counter back to 232 (242) [252] and complete the left half. Follow the instructions from * but don't forget to complete the shoulder shapings.

Hang the sts. held on waste yarn onto the machine, decreasing to 108 (118) [130] sts. Remove the waste yarn then hang every other stitch onto the Ribber, turn the Row Counter to 0 and work K1, P1 Ribbing with color stripes of 10 rows color 2, 8 rows color 1, 24 rows color 2, 8 rows color 1, 10 rows color 2. After Row 60, bind off the crochet method for Ribbing.

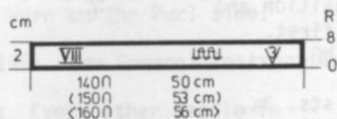
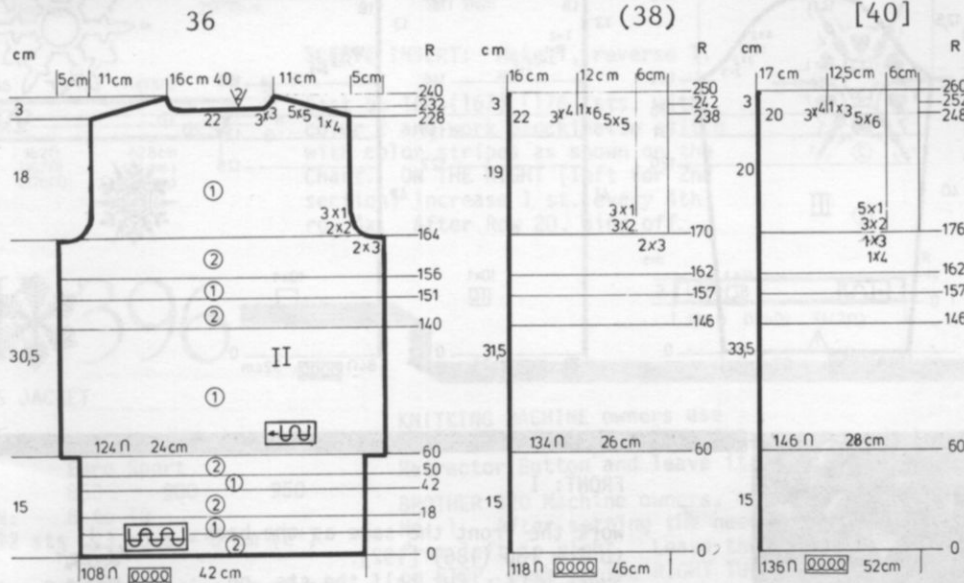

FRONT BANDS: VIII Make.2

Cast on 140 (150) [160] sts. with color 1 and work 8 rows K1, P1 Ribbing then bind off the crochet method for Ribbing.

FRONT: I Make 1, reverse 1.

OPEN CAST ON. With waste yarn, cast on 60 (66) [72] sts. Knit 8 to 10 rows, then change to color 1 and put Counter at 60.

Work Stockinette stitch with color stripes as shown on the Chart. After Row 164 (170) [176], continue with color 1.

After Row 165 (171) [177], SHAPE ARMHOLE: Bind off

4 sts. 1x, 3 sts. 2x, 1 st. 4x, then every 10th row 1 st. 3x.

(4 sts. 1x, 3 sts. 2x, 2 sts. 3x, 1 st. 2x, then every 10th row 1 st. 1x.).

[4 sts. 1x, 3 sts. 3x, 2 sts. 3x, 1 st. 2x, then every 10th row 1 st. 2x].

Knit to Row 214 (222) [228].

SHAPE NECK: Bind off

3 sts. 2x, 2 sts. 2x, 1 st. 4x. (3 sts. 2x, 2 sts. 3x; 1 st. 4x).

[3 sts. 2x, 2 sts. 4x, 1 st. 4x].

After Row 229 (239) [249], SHAPE SHOULDER: Bind off

4 sts. 1x, 5 sts. 5x. (5 sts. 5x, 6 sts. 1x).

[5 sts. 5x, 6 sts. 1x].

Hang the sts. held on waste yarn onto the machine, decreasing to 50 (56) [62] sts. Transfer every other stitch to the Ribber and work the Color stripes the same as the back. After Row 60, bind off the crochet method for Ribbing.

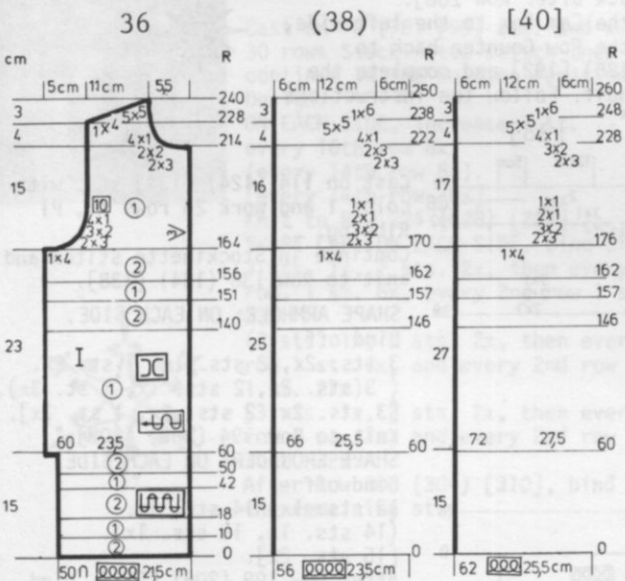

HP 394

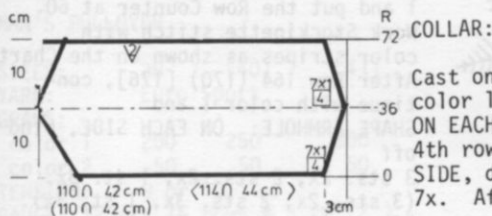

COLLAR:
 Cast on 110 (110) [114] sts. with color 1 and work Stockinette stitch. ON EACH SIDE, increase 1 st. every 4th row 7x. After Row 36, ON EACH SIDE, decrease 1 st. every 4th row 7x. After Row 72, bind off.

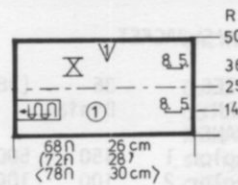

36 CUFFS: X Make 2.
 Cast on 68 (72) [78] sts. with color 1 and work Stockinette stitch. After Row 14 and 36, MAKE BUTTONHOLES over needles 5 to 8 counting from the right (left for 2nd cuff) edge. After Row 50, bind off.

SLEEVES: III

Cast on 70 (78) [84] sts. with color 1 and work Stockinette stitch. ON EACH SIDE, increase 1 st. every 14th row 9x (10x) [10x]. After Row 120 (126) [126], work the color stripes as shown on the Chart. After Row 142 (146) [150], continue with color 1 and SHAPE CAP: ON EACH SIDE, bind off 4 sts. 1x, 3 sts. 2x, 2 sts. 2x, 1 st. 15x, 2 sts. 4x. (4 sts. 1x, 3 sts. 2x, 2 sts. 2x, 1 st. 12x, 2 sts. 7x). [4 sts. 1x, 3 sts. 2x, 2 sts. 3x, 1 st. 12x, 2 sts. 7x]. After Row 192 (196) [200], bind off the remaining sts.

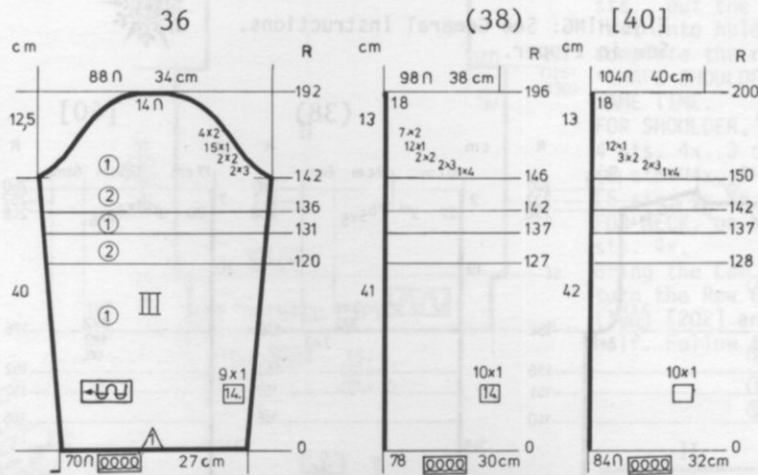

HP 395

TEEN BOY'S PULLOVER

SIZES: 32 (36) [38]
YARN: Binia
GRAMS:
 color 1 350 (400) [450]
 color 2 50 50 50
TENSION: 8 to 10
GAUGE: 13 sts. 18 rows = 5 cm (2")



Stockinette stitch worn on the Purl side. The Sleeves are knitted sideways in 3 sections. Bands are K1, P1 Ribbing.

FINISHING: See General Instructions. Sew the striped band of sleeve to each side of the inside edge of Sleeve sections.

FRONT: I

Work the front the same as the back to Row 180 (186) [192].
SHAPE NECK: Put half the sts. on the left into holding position and complete the right side first. WATCH FOR SHOULDER SHAPING.
 *ON NECK SIDE, bind off 5 sts. 1x, 3 sts. 2x, 2 sts. 3x, 1 st. 3x and SHAPE SHOULDER same as the back after Row 194. (5 sts. 1x, 3 sts. 2x, 2 sts. 4x, 1 st. 3x and SHAPE SHOULDER same as the back after Row 202). [5 sts. 1x, 3 sts. 2x, 2 sts. 5x, 1 st. 3x and SHAPE SHOULDER same as the back after Row 208]. Move the Cam Box to the left side, turn the Row Counter back to 180 (186) [192] and complete the left half. Follow the instructions from *.



BACK: II

Cast on 114 (124) [134] sts. with color 1 and work 26 rows K1, P1 Ribbing. Continue in Stockinette stitch and knit to Row 130 (134) [138].
SHAPE ARMHOLE: ON EACH SIDE, bind off 3 sts. 2x, 2 sts. 1x, 1 st. 2x. (3 sts. 2x, 2 sts. 1x, 1 st. 3x). [3 sts. 2x, 2 sts. 2x, 1 st. 3x]. Knit to Row 194 (202) [208].
SHAPE SHOULDER: ON EACH SIDE, bind off 13 sts. 1x, 14 sts. 1x. (14 sts. 1x, 15 sts. 1x). [15 sts. 2x]. After Row 198 (206) [212], bind off the remaining sts.

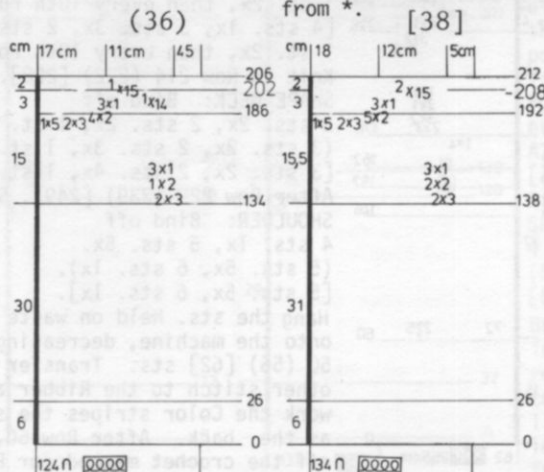
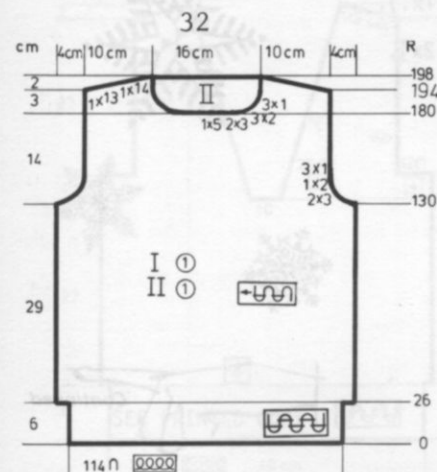

32

(36)

[38]

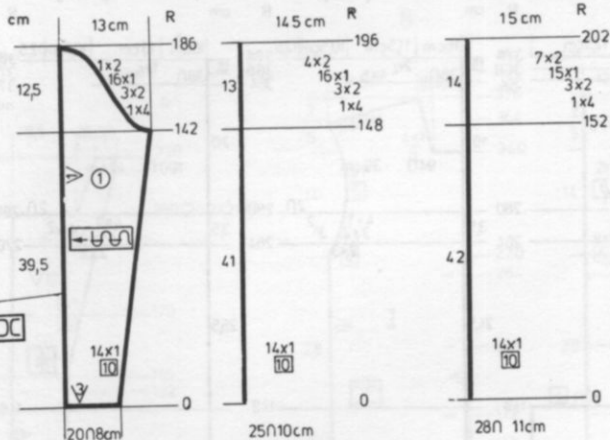

SLEEVES: Make 2, REVERSE 2.

Cast on 20 (25) [28] sts. with color 1 and work Stockinette stitch. ON THE RIGHT (left for reversed sections) increase 1 st. every 10th row 14x. After Row 142 (148) [152], SHAPE CAP: Bind off 4 sts. 1x, 2 sts. 3x, 1 st. 16x, 2 sts. 1x. (4 sts. 1x, 2 sts. 3x, 1 st. 16x, 2 sts. 4x). [4 sts. 1x, 2 sts. 3x, 1 st. 15x, 2 sts. 7x]. After Row 186 (196) [202], bind off the remaining sts.

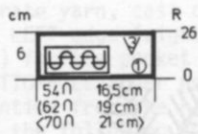

SLEEVE BANDS: Make 2.

Cast on 54 (63) [70] sts. with waste yarn and work K1, P1 Ribbing. Knit 8 to 10 rows, then change to color 1 and put Counter at 0. Knit 26 rows. Remove the sts. onto contrast waste yarn.



NECKBAND:

Cast on 130 (136) [142] sts. with color 1 and work 14 rows K1, P1 Ribbing then bind off the crochet method for Ribbing.

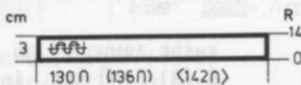

SLEEVE INSERT: Make 1, reverse 1.

Cast on 162 (167) [176] sts. with color 2 and work Stockinette stitch with color stripes as shown on the Chart. ON THE RIGHT (left for 2nd section) increase 1 st. every 4th row 4x. After Row 20, bind off.

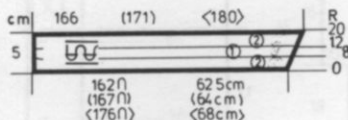

DK 396

WOMAN'S JACKET

SIZES: 8 (10) [12]
 YARN: Euro Sport
 GRAMS: 850 900 950
 TENSION: 8 to 10
 GAUGE: 12 sts. 23 rows = 5 cm (2")

A Holding Position Design as given below. Worn on the Purl side.

FINISHING: See General Instructions.

PATTERN: Every other needle in holding position, knit 1 row. All needles in work, knit 1 row. REPEAT.

KNITTING MACHINE owners use Wheel No. 6, push in the Right Retractor Button and leave it there.

BROTHER 820 Machine owners, use Card No. 1. After setting the needles from left to right. Leave the setting on STOP, push in the RIGHT TUCK Button and leave it there.



COLLAR: VI

Cast on 100 sts. and work the Holding Position Design. ON EACH SIDE, increase 2 sts. every 2nd row 5x. After Row 46, continue in Stockinette stitch. Knit to Row 74. ON EACH SIDE, bind off 3 sts. 2x, 4 sts. 1x, After Row 80, bind off the remaining sts.

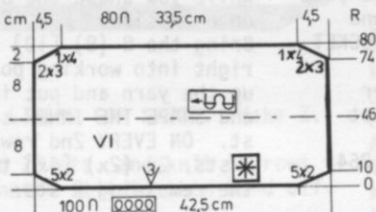

SLEEVES: III

Cast on 70 (76) [80] sts. and work 30 rows Stockinette stitch then continue in the Holding Position Design. ON EACH SIDE, increase 1 st. every 16th row 8x. (every 14th row 8x). [every 14th row 10x]. Knit to Row 224 (228) [228]. SHAPE CAP: ON EACH SIDE, bind off 3 sts. 1x, 2 sts. 2x, then every 4th row, 1 st. 6x, every 2nd row 1 st. 23x. (3 sts. 1x, 2 sts. 2x, then every 4th row 1 st. 4x, and every 2nd row 1 st. 27x). [3 sts. 1x, 2 sts. 2x, then every 4th row 1 st. 3x, and every 2nd row 1 st. 32x. After Row 300 (304) [310], bind off the remaining sts.

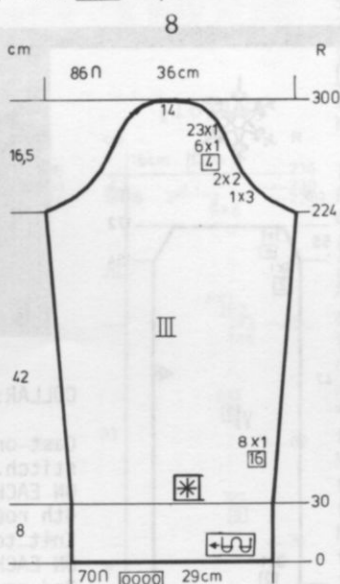

(10)

[12]

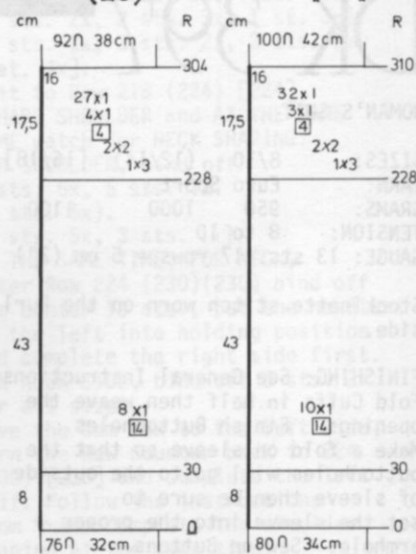

Continued



DK 396

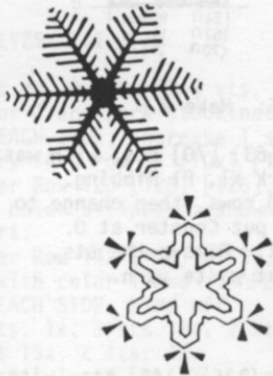
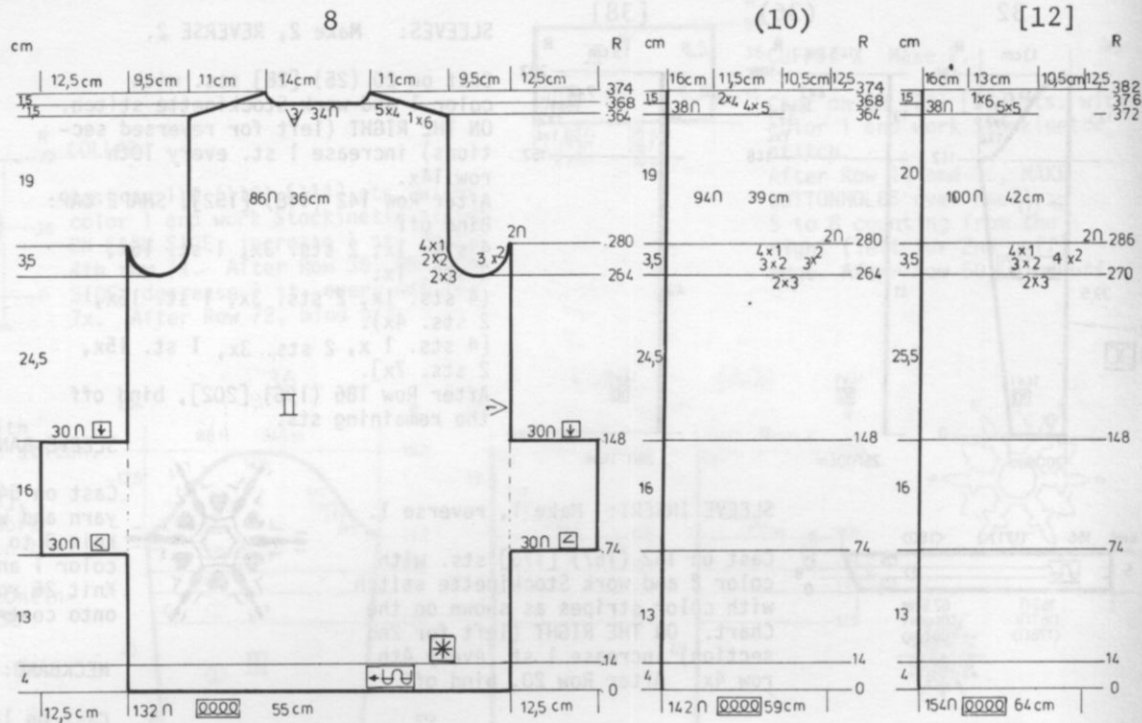

BACK: II

Cast on 132 (142) [154] sts. and work 14 rows Stockinette stitch. Continue in the Holding Position Design.

Knit to Row 74.

For the first size ONLY, cast on 30 sts. ON EACH SIDE for the pocket (use separate yarn for left side).

For the 2nd and 3rd sizes, the pockets must be made separately and sewn in place. SEE SEPARATE POCKET INSTRUCTIONS.

FOR THE FIRST SIZE ONLY, after Row 148, bind off the 30 pocket sts. ON EACH SIDE.

ALL SIZES: Knit to Row 264 (264) [270].

SHAPE ARMHOLE: ON EACH SIDE, put 8 (8) [10] sts. into holding position. Leave the yarn hanging on the right side and use another yarn to shape the armhole and you will pick up this dropped yarn later. SHAPE ARMHOLE:

ON EACH SIDE, bind off 3 sts. 2x, 2 sts. 2x, 1 st. 4x. (3 sts. 2x, 2 sts. 3x, 1 st. 4x). [Same as 2nd size].

Drop this yarn and put all the sts. that are left into holding position while you shape the 8 (8) [10] sts. on each side.

Bring the 8 (8) [10] sts. on the right into working position, pick up the yarn and put into feeder, and SHAPE THE INNER section of these st. ON EVERY 2nd row, bind off 3 sts. 2x (2x) [4x] then bind off the remaining 2 sts.

Bring the Cam Box to the right side, pick up the yarn you dropped, put the Row Counter to 264 (264) [270] and continue.

Knit to Row 364 (364) [372]. SHAPE SHOULDER: and WATCH FOR NECK SHAPING.

FOR SHOULDER, bind off 6 sts. 1x, 4 sts. 5x.

(5 sts. 4x, 4 sts. 2x).

[5 sts. 5x, 6 sts. 1x].

FOR NECK: After Row 368 (368)

[376], bind off the center 34 (38)

[38] sts. put the needles on the left into holding position and continue the SHOULDER SHAPING as given above.

Bring the needles on the left into working position, knit 1 row in Pattern to the left side, turn the Row Counter back to 368 (368) [376] and complete the shoulder shapings.

DK 397

WOMAN'S SUIT

SIZES: 8/10 (12/14) [16/18]

YARN: Euro Sport

GRAMS: 950 1000 1100

TENSION: 8 to 10

GAUGE: 13 sts. 17 rows = 5 cm (2")

Stockinette stitch worn on the Pur1 side.

FINISHING: See General Instructions. Fold Cuffs in half then weave the openings. Finish Buttonholes.

Make a fold on sleeve so that the buttonholes will go to the outside of sleeve then be sure to set the sleeve into the proper armhole. Sew on Buttons.

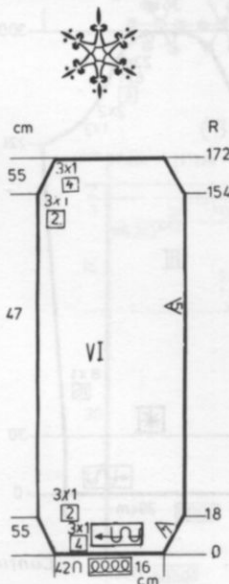

COLLAR:

Cast on 42 sts. and work Stockinette stitch.

ON EACH SIDE, increase 1 st. every 4th row 3x, every 2nd row 3x.

Knit to Row 154.

ON EACH SIDE, decrease 1 st. every 2nd row 3x, every 4th row 3x.

After Row 172, bind off the remaining sts.

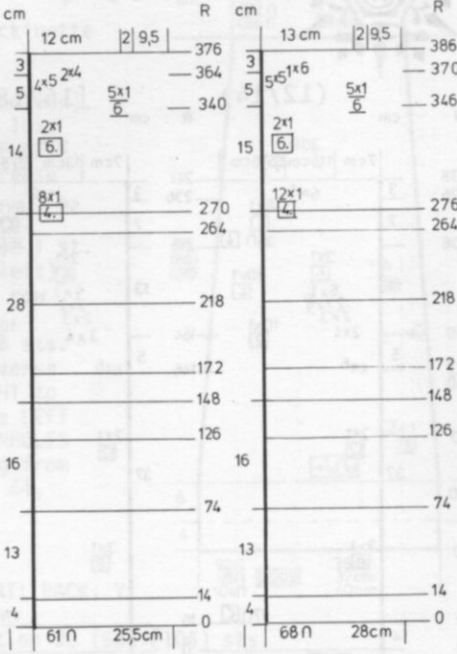
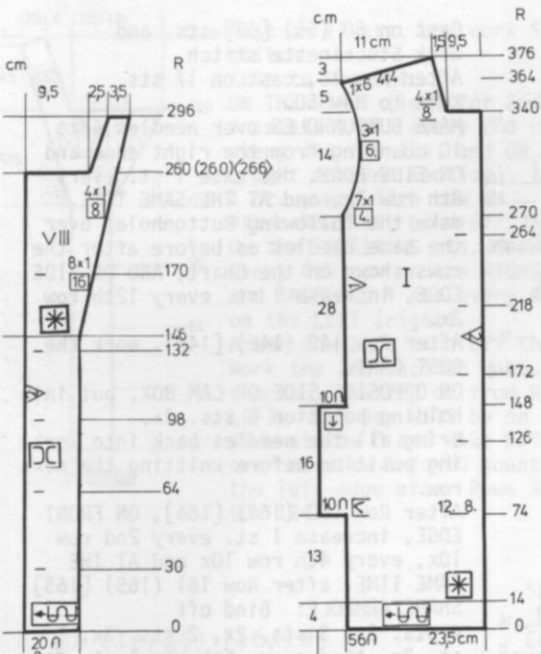

FRONT: I Make 1, reverse 1 and omit the buttonholes in 2nd section.

Cast on 56 (61) [68] sts. and work 14 rows Stockinette stitch. Continue in the Holding Position Design.

Knit to Row 74. With a separate yarn, cast on 10 sts. on the LEFT edge (right for 2nd section) for the pocket facing, and make BUTTONHOLES over needles 8 to 12 counting from the right edge. Make the following Buttonholes over the same needles after the rows shown on the Chart.

After Row 148, bind off the 10 facing sts. on the left (right). Knit to Row 270 (270) [276]. SHAPE ARMHOLE on the left (right for 2nd section). ON EVERY 4th row, decrease 1 st. 7x (8x) [12x]. Knit to Row 340 (340) [346]. Bind off 22 sts. for neck and ON ARM SIDE, on every 6th row increase 1 st. 3x (2x) [2x] AND AT THE SAME TIME, ON NECK SIDE, decrease 1 st. every 8th row 4x and SHAPE SHOULDER after Row 365.

FRONT FACINGS: VIII Make 1, reverse 1 and omit the buttonholes.

Cast on 20 sts. and work Stockinette stitch. MAKE BUTTONHOLES over needles 8 to 12 counting from the LEFT edge after the Rows shown on the Chart. After Row 146, continue in the Holding position Design.

After Row 170, on the RIGHT (left) increase 1 st. every 16th row 8x. After Row 261 (261) [267], bind off 22 sts. for neck. Over the remaining 10 sts. on the RIGHT (left) increase 1 st. and on the LEFT (right) decrease 1 st. every 8th row 4x. After Row 296, bind off.

POCKET for 2nd and 3rd sizes: Make 2.

Cast on 30 sts. and knit 74 rows in Pattern then bind off.

(every 6th row 5x, AND SHAPE SHOULDER after Row 365). [every 6th row 5x AND SHAPE SHOULDER after Row 371]. FOR SHOULDER, bind off 6 sts. 1x, 4 sts. 5x. (5 sts. 4x, 4 sts. 2x). [5 sts. 5x, 6 sts. 1x].

BACK: II

Cast on 120 (132) [144] sts. and work Stockinette stitch. Knit to Row 36. ON EACH SIDE, decrease 1 st. every 8th row 3x. After Row 62 ON EACH SIDE, increase 1 st. every 6th row 2x. Knit to Row 152 (156) [156]. SHAPE ARMHOLE: ON EACH SIDE, bind off 3 sts. 2x, 2 sts. 3x, 1 st. 2x. (3 sts. 2x, 2 sts. 3x, 1 st. 3x). [4 sts. 1x, 3 sts. 2x, 2 sts. 2x, 1 st. 4x].

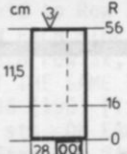
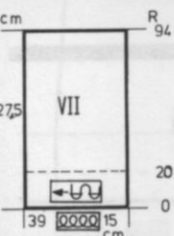

POCKET LINING FOR SKIRT: Make 2. Cast on 28 sts. and knit 56 rows Stockinette stitch, then bind off.

POCKETS for JACKET: Make 2. Cast on 39 sts. and work 94 rows Stockinette stitch then bind off.

8/10

(12/14)

[16/18]

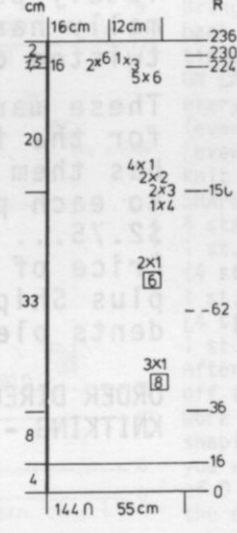
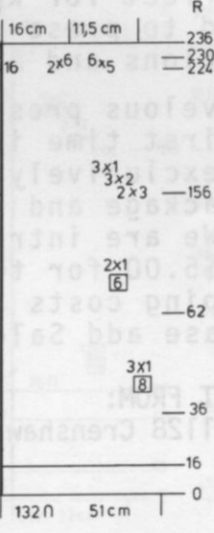
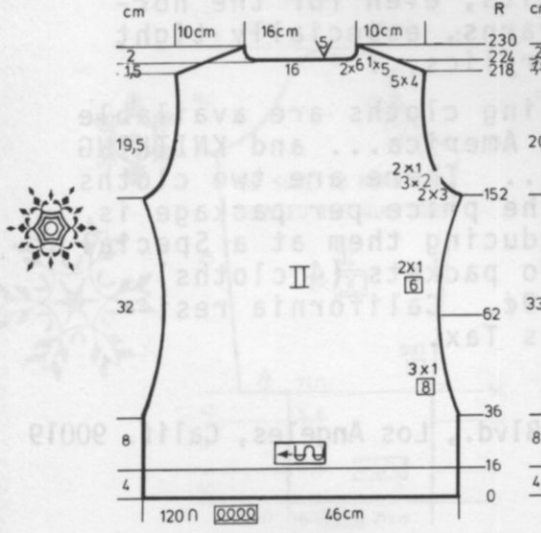

Knit to Row 218 (224) [224]. SHAPE SHOULDER and AT THE SAME TIME watch for NECK SHAPING. FOR SHOULDER, bind off 4 sts. 5x, 5 sts. 1x. (5 sts. 6x). [6 sts. 5x, 3 sts. 1x]. AT THE SAME TIME, FOR NECK, after Row 224 (230) [230] bind off the center 16 sts., put the needles on the left into holding position and complete the right side first. *ON NECK SIDE, bind off 6 sts. 2x for all sizes.

Move the Cam Box to the left side, turn the Row Counter back to 224 (230) [230] and complete the left half. Follow the instructions from * and complete the shoulder shaping at the same time.

Continued



DK 397



FRONT: I Make 1, reverse 1 and omit the Buttonholes.

Cast on 50 (55) [63] sts. and work Stockinette stitch. After Row 16, cast on 17 sts. Knit to Row 50.

MAKE BUTTONHOLES over needles 6 to 10 counting from the right edge and ON SIDE EDGE, decrease 1 st. every 8th row 3x, and AT THE SAME TIME, make the following Buttonholes over the same needles as before after the rows shown on the Chart, AND ON SIDE EDGE, increase 1 st. every 12th row 2x.

After Row 142 (146) [146], work the BUST DART. ON OPPOSITE SIDE OF CAM BOX, put into holding position 6 sts. 4x. Bring all the needles back into working position before knitting the next row.

After Row 160 (164) [164], ON FRONT EDGE, increase 1 st. every 2nd row 10x, every 4th row 10x and AT THE SAME TIME, after Row 161 (165) [165], SHAPE ARMHOLE: Bind off

4 sts. 2x, 3 sts. 2x, 2 sts. 3x, 1 st. 3x, then every 6th row 1 st. 3x. (4 sts. 2x, 3 sts. 2x, 2 sts. 2x, 1 st. 5x then every 6th row 1 st. 3x). [4 sts. 3x, 3 sts. 2x, 2 sts. 3x, 1 st. 4x, then every 6th row 1 st. 3x]. After Row 206 (216) [216], bind off 35 sts.

Knit to Row 227 (237) [237].

SHAPE SHOULDER: Bind off

5 sts. 1x, 4 sts. 5x.

(5 sts. 6x)

[6 sts. 5x, 3 sts. 1x].

Work the 2nd section with reverse shaping and OMIT the Buttonholes.

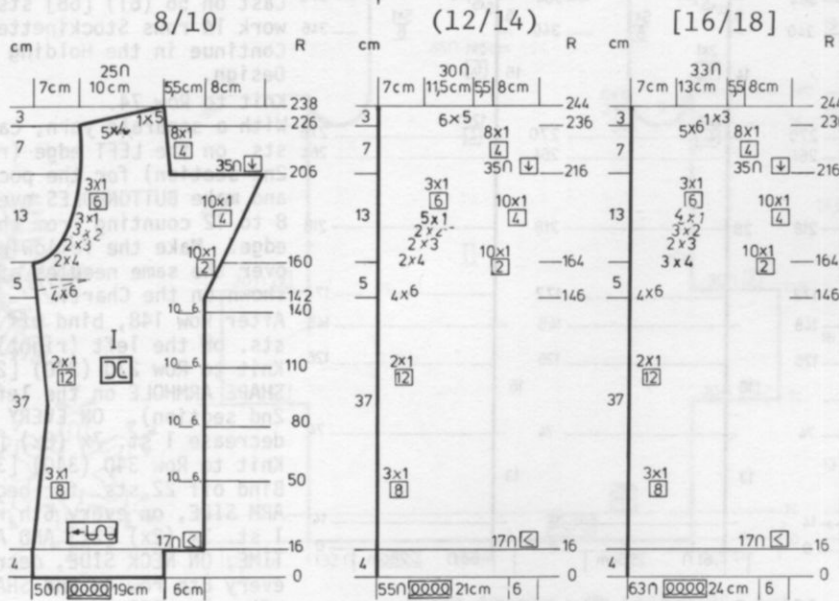

BE SURE TO NOTIFY US IMMEDIATELY OF ANY CHANGE OF ADDRESS. THE POST OFFICE WILL NOT FORWARD YOUR MAGAZINE TO YOU.



NEW! Pressing Cloths

New Miracle fibre pressing cloths... absolutely perfect for knits, even for the normally hard to press yarns, especially tight twisted orlons and acrylics...

These marvelous pressing cloths are available for the first time in America... and KNITKING has them exclusively... There are two cloths to each package and the price per package is \$2.75... We are introducing them at a Special Price of \$5.00 for two packets (4 cloths) plus Shipping costs 39¢. California residents please add Sales Tax.

ORDER DIRECT FROM:

KNITKING - 1128 Crenshaw Blvd., Los Angeles, Calif. 90019



FRONT FACING: Make 2 but DO NOT MAKE BUTTONHOLES in this section.

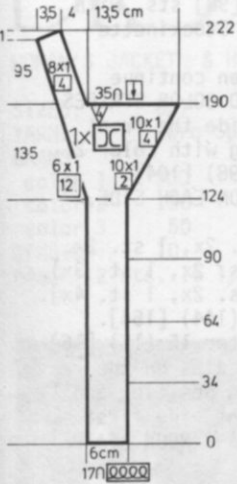

Cast on 17 sts. and work Stockinette stitch.
 Knit to Row 124.
 ON THE RIGHT (left for 2nd section), increase 1 st. every 2nd row 10x, every 4th row 10x, and ON THE LEFT, (right for 2nd section), increase 1 st. every 12th row 6x.
 After Row 190, bind off 35 sts.
 On the REMAINING sts. decrease 1 st. every 4th row on the RIGHT (left) and INCREASE 1 st. every 4th row on the LEFT (right).
 After Row 222, bind off the 8 sts.
 Work the 2nd section with reverse shaping, casting on from RIGHT to LEFT. Cam Box will be on the LEFT side at Row 0 and make BUTTONHOLES over needles 6 to 10 counting from the left edge after Rows 34, 64, 90, 124.

8/10 (12/14) [16/18]

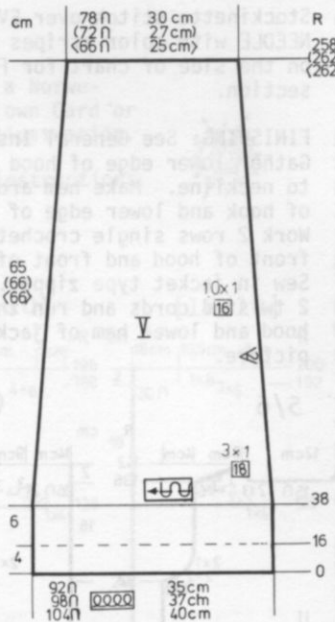

SKIRT: BACK: V

Cast on 92 (98) [104] sts. and work Stockinette stitch.
 Knit to Row 38.
 ON EACH SIDE, decrease 1 st. every 18th row 3x, every 16th row 10x.
 After Row 258 (262) [262], bind off the remaining sts.

8/10 (12/14) [16/18]

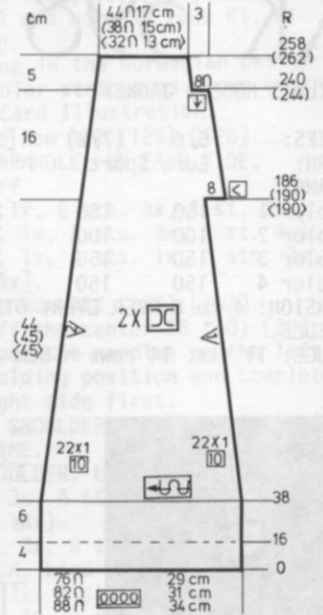

SKIRT SIDE PANELS: Make 1, reverse 1.

Cast on 76 (82) [88] sts. and work Stockinette stitch.
 Knit to Row 38.
 ON EACH SIDE, decrease 1 st. every 10th row 2x, BUT AT THE SAME TIME, after Row 186 (190) [190], on the RIGHT (left for 2nd section) cast on 8 sts. and after Row 240 (244) [244], bind off the 8 sts.
 After Row 258 (262) [262], bind off the remaining sts.

8/10 (12/14) [16/18]

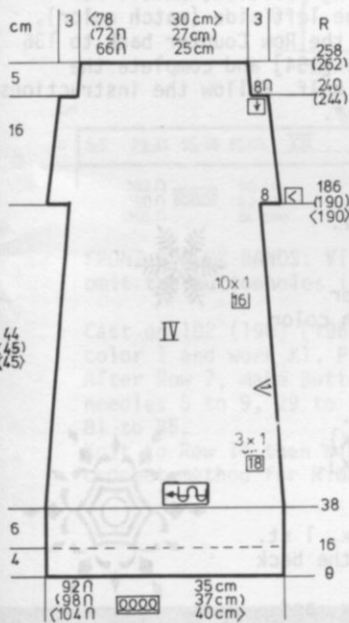

SKIRT FRONT: IV

Cast on 92 (98) [104] sts. and work Stockinette stitch.
 Knit to Row 38.
 ON EACH SIDE, decrease 1 st. every 18th row 3x, every 16th row 10x BUT AT THE SAME TIME, after Row 186 (190) [190], cast on 8 sts. ON EACH SIDE.
 After Row 240 (244) [244], ON EACH SIDE, bind off 8 sts.
 After Row 258 (262) [262], bind off the remaining sts.

SLEEVES: III - Make 1, reverse 1.

To the LEFT of 0 (right for 2nd sleeve), cast on 18 sts. and work Stockinette stitch. Knit 56 rows.
 Put these 18 sts. into holding position. Directly to the RIGHT (left), of these 18 sts. cast on 56 (58) [62] sts. Put Counter at 0 and work Stockinette stitch.
 After Rows 16 and 40, make BUTTONHOLES over needles 5 to 8 counting from the left (right for 2nd sleeve). Knit to Row 56.
 Bring the needles in holding position back into working position and continue over all 74 (76) [80] stitches.
 ON EACH SIDE, increase 1 st. every 14th row 9x.
 (every 10th row 12x)
 [every 10th row 12x].
 Knit to Row 176 (180) [180].
 SHAPE CAP: ON EACH SIDE, bind off 4 sts. 1x, 3 sts. 2x, 2 sts. 2x, 1 st. 20x, 2 sts. 2x.
 (4 sts. 1x, 3 sts. 2x, 2 sts. 3x, 1 st. 20x, 2 sts. 2x).
 [4 sts. 1x, 3 sts. 2x, 2 sts. 3x, 1 st. 20x, 2 sts. 3x].
 After Row 230 (236) [238], bind off the remaining sts.
 Work the 2nd sleeve with reverse shaping for the Cuff section so you will cast on 18 sts. to the right of 0 instead of left, then cast on the other sts. to the left of these.

8/10 (12/14) [16/18]

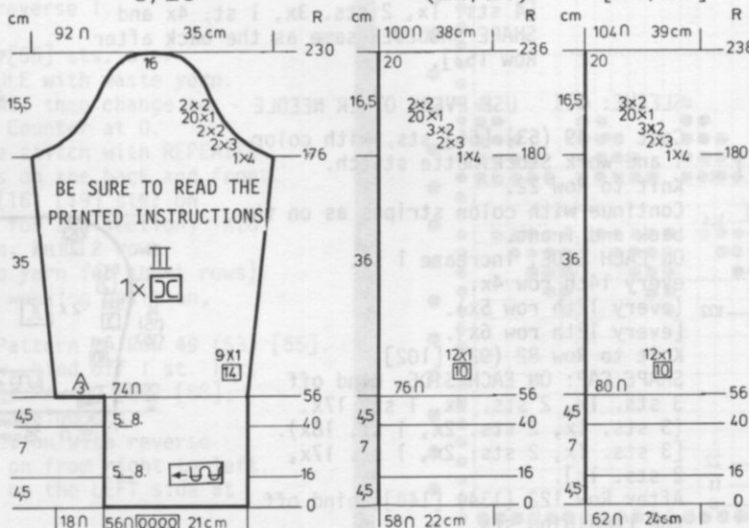

KK 398

CHILD'S HOODED JACKET

SIZES: 5/6 (7/8) [9/10]
YARN: Euro Sport
GRAMS:
 color 1 150 150 200
 color 2 100 100 100
 color 3 150 150 150
 color 4 150 150 150
TENSION: 4 to 6 OVER EVERY OTHER NEEDLE.
GAUGE: 11 sts. 14 rows = 5cm (2")

Stockinette stitch over EVERY OTHER NEEDLE with color stripes as shown on the side of chart for Front section.

FINISHING: See General Instructions. Gather lower edge of hood and sew to neckline. Make hem around front of hook and lower edge of jacket. Work 2 rows single crochet around front of hood and front of jacket. Sew in jacket type zipper. Make 2 twisted cords and run through hood and lower hem of jacket. See picture.

BACK: USE EVERY OTHER NEEDLE

Cast on 81 (90) [98] sts. with color 1 and work Stockinette stitch.
 Knit 22 rows, then continue with the REPEATED COLOR STRIPES as shown along side the front section beginning with color 2. Knit to Row 92 (98) [104].
SHAPE ARMHOLE: ON EACH SIDE, bind off
 3 sts. 1x, 2 sts. 2x, 1 st. 2x. (3 sts. 1x, 2 sts. 2x, 1 st. 3x). [3 sts. 1x, 2 sts. 2x, 1 st. 4x]. Knit to Row 136 (144) [154].
SHAPE ARMHOLE: ON EACH SIDE, bind off
 3 sts. 1x, 2 sts. 2x, 1 st. 2x. (3 sts. 1x, 2 sts. 2x, 1 st. 3x). [3 sts. 1x, 2 sts. 2x, 1 st. 4x]. Knit to Row 136 (144) [154].
 Bind off the center 15 (16) [16] sts., put the needles on the left into holding position and complete the right side first.
***SHAPE SHOULDER AND NECK AT THE SAME TIME.**
FOR SHOULDER, bind off
 6 sts. 3x.
 (7 sts. 3x).
 [8 sts. 3x].
FOR NECK, bind off
 3 sts. 2x.
 Bring the needles on the left into working position, knit 1 row to the left side (watch color), turn the Row Counter back to 136 (144) [154] and complete the left half. Follow the instructions from *.

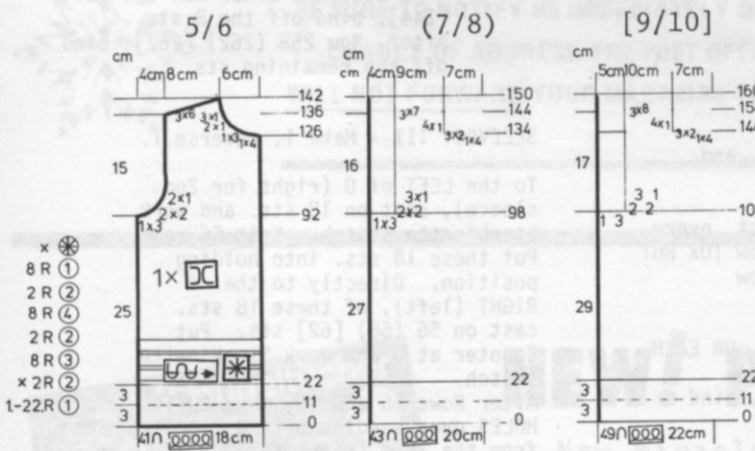
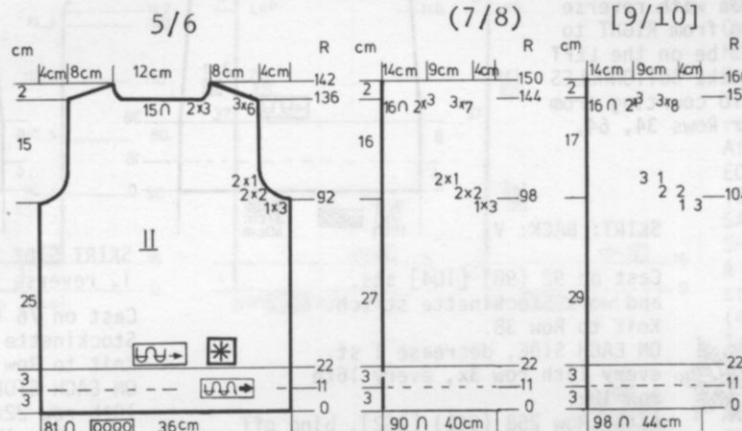

FRONT: I Make 1, reverse 1.

Cast on 41 (45) [49] sts. over EVERY OTHER NEEDLE with color 1. Work Stockinette stitch. Knit to Row 22. Continue with the REPEATED color stripes as shown beginning with color 2. Knit to Row 91 (97) [103].
SHAPE ARMHOLE: Bind off
 3 sts. 1x, 2 sts. 2x, 1 st. 2x. (3 sts. 1x, 2 sts. 2x, 1 st. 3x). [3 sts. 1x, 2 sts. 2x, 1 st. 4x]. Knit to Row 126 (134) [144].
SHAPE NECK: Bind off
 4*sts. 1x, 3 sts. 1x, 2 sts. 2x, 1 st. 3x AND SHAPE SHOULDER same as the back after Row 135. (4 sts. 1x, 2 sts. 3x, 1 st. 4x, and SHAPE SHOULDER same as the back after Row 143). [4 sts. 1x, 2 sts. 3x, 1 st. 4x and SHAPE SHOULDER same as the back after Row 153].



SLEEVE: III USE EVERY OTHER NEEDLE

Cast on 49 (53) [55] sts. with color 1 and work Stockinette stitch. Knit to Row 22. Continue with color stripes as on the back and front. ON EACH SIDE, increase 1 st. every 14th row 4x. (every 12th row 5x). [every 12th row 6x]. Knit to Row 82 (92) [102].
SHAPE CAP: ON EACH SIDE, bind off
 3 sts. 1x, 2 sts. 2x, 1 st. 17x. (3 sts. 1x, 2 sts. 2x, 1 st. 18x). [3 sts. 1x, 2 sts. 2x, 1 st. 17x, 2 sts. 1x]. After Row 122 (134) [144], bind off the remaining sts.

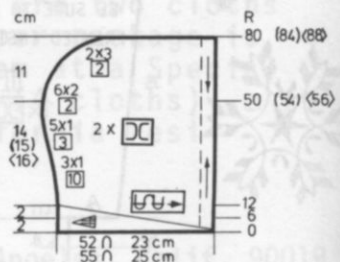
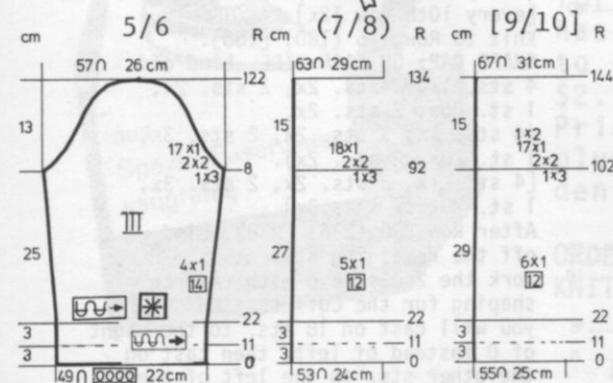

DK 399

WOMAN'S JACKET & Hat

SIZES: 6/7 (8/10) [12/14]
YARN: Euro Sport
GRAMS:
 color 1 300 (350) [400]
 color 2 150 200 200
 color 3 50 50 50
TENSION: 10
GAUGE: 12 sts. 16 1/2 rows = 5 cm

Stockinette stitch with a Norwegian Design. Punch your own Card or follow the Punch Card Illustration.

FINISHING: See General Instructions.



Cast on 106 (116) [124] sts. with color 1 and work 40 rows K1, P1 Ribbing.
 Continue in the Norwegian Design with color stripes as shown on the Punch Card Illustration.
 Knit to Row 122 (128) [128].
SHAPE ARMHOLE: ON EACH SIDE, bind off
 3 sts. 1x, 2 sts. 3x, 1 st. 3x.
 (4 sts. 1x, 2 sts. 3x, 1 st. 4x).
 [4 sts. 1x, 3 sts. 1x, 2 sts. 2x, 1 st. 4x].
 Knit to Row 182 (188) [192].
 Bind off the center 28 (30) [30] sts., put the needles on the left into holding position and complete the right side first.
***SHAPE SHOULDER AND NECK AT THE SAME TIME.**
FOR SHOULDER, bind off
 6 sts. 3x, 4 sts. 1x.
 (6 sts. 4x).
 [6 sts. 3x, 8 sts. 1x].
FOR NECK, bind off
 2 sts. 1x, 1 st. 3x.
 (2 sts. 1x, 1 st. 3x).
 [2 sts. 2x, 1 st. 2x].
 Bring the needles on the left into working position, knit 1 row in Pattern to the left side, turn the Row Counter back to 182 (188) [192] and complete the left half.
 Follow the instructions from *.

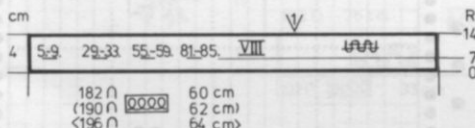
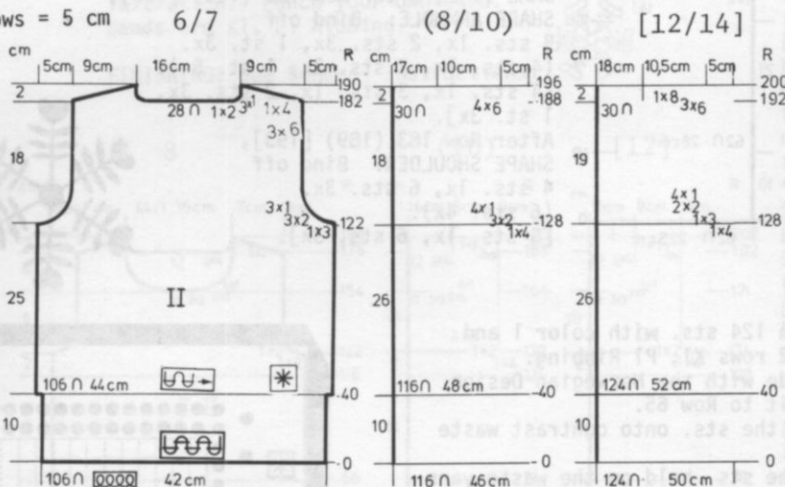

FRONT & NECK BANDS: VIII Make 2 but omit the buttonholes in 2nd section.

Cast on 182 (190) [196] sts. with color 1 and work K1, P1 Ribbing.
 After Row 7, make Buttonholes over needles 5 to 9, 29 to 33, 55 to 59, 81 to 85.
 Knit to Row 14 then bind off the crochet method for Ribbing.



HOOD: Make 1, reverse 1.

Cast on 52 (52) [55] sts. over EVERY OTHER NEEDLE with waste yarn.
 Knit 8 to 10 rows, then change to color 1 and put Counter at 0.
 Work Stockinette stitch with REPEATED color stripes as on the back and front.
 Put all but 16 (16) [19] sts. on the left (right for 2nd section) into holding position, knit 2 rows. (be sure to wrap yarn for short rows).
 Bring back into working position, 6 sts. 6x.
 Knit in stripe Pattern to Row 49 (53) [55].
ON EVERY 2nd row, bind off 1 st. 13x, 2 sts. 3x. After Row 80 (84) [88], bind off the remaining sts.
 Make the 2nd section with reverse shaping casting on from right to left. Cam Box will be on the LEFT side at Row 0.

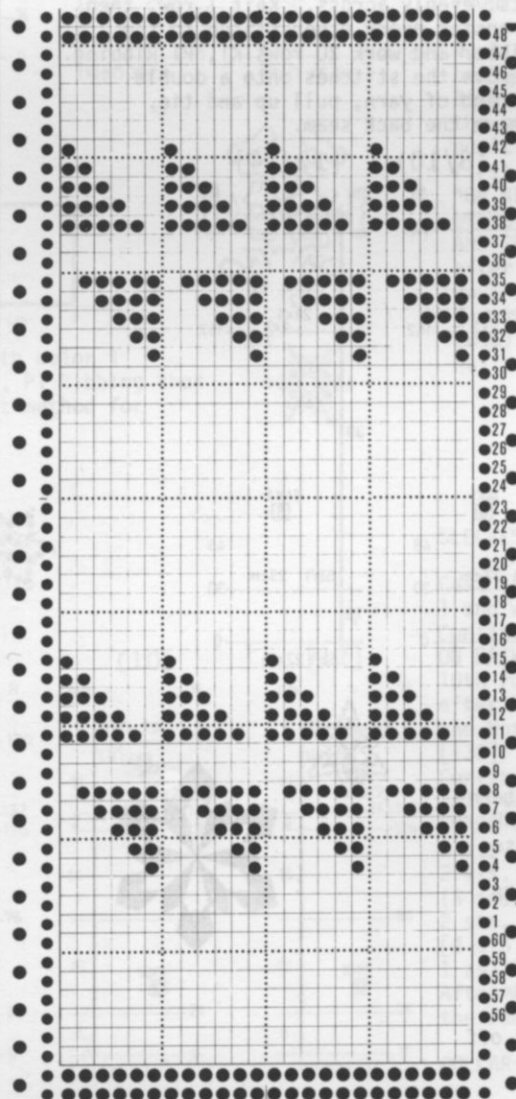

The Pattern is a REPEAT of 27 rows as follows:

- 2 rows color 2
- 1 row color 3
- 2 rows color 2
- 5 rows color 1
- 5 rows Norwegian Design with colors 1 & 2
- 2 rows color 2
- 5 rows Norwegian Design with color 1 & 2
- 5 rows color 1

REPEAT from the beginning.

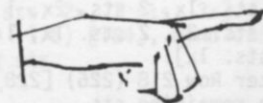

Continued

DK 399

FRONT: Make 1, reverse 1.

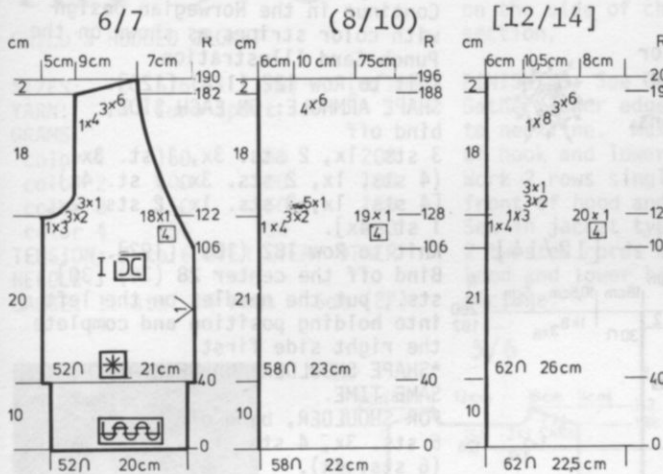

Cast on 52 (58) [62] sts. with color 1 and work 40 rows K1, P1 Ribbing. Continue with the Norwegian Design with color stripes as shown on the Punch Card Illustration. Knit to Row 106.
 ON FRONT EDGE, decrease 1 st. every 4th row 18x (19x) [20x] AND AT THE SAME TIME, after Row 123 (129) [129],
 SHAPE ARMHOLE: Bind off 3 sts. 1x, 2 sts. 3x, 1 st. 3x. (4 sts. 1x, 2 sts. 3x, 1 st. 5x). [4 sts. 1x, 3 sts. 1x, 2 sts. 3x, 1 st. 3x].
 After Row 183 (189) [193],
 SHAPE SHOULDER: Bind off 4 sts. 1x, 6 sts. 3x. (6 sts. 4x). [8 sts. 1x, 6 sts. 3x].

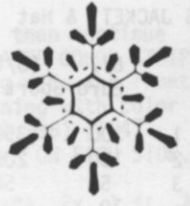

HAT:

Cast on 124 sts. with color 1 and work 12 rows K1, P1 Ribbing. Continue with the Norwegian Design and knit to Row 65. Remove the sts. onto contrast waste yarn. Hang the sts. held on the waste yarn back onto the machine, decreasing 30 sts. evenly across. Knit 1 row, then transfer every other stitch to the Ribber and work 20 rows K1, P1 Ribbing. Remove the stitches onto a double strand of yarn, pull up and tie. Weave the back seam.

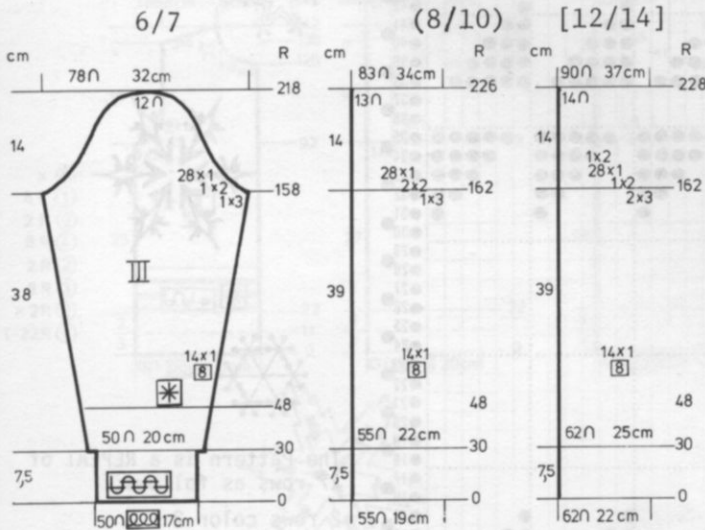
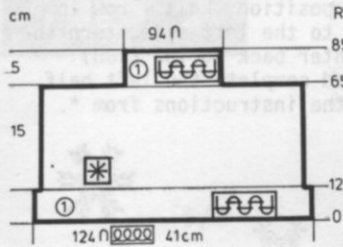

SLEEVES: III

Cast on 50 (55) [62] sts. with color 1 and work 30 rows K1, P1 Ribbing. Continue with the Pattern BEGINNING with ROW 18, AND AT THE SAME TIME, ON EACH SIDE, increase 1 st. every 8th row 14x. After Row 158 (162) [162], SHAPE CAP: ON EACH SIDE, bind off 3 sts. 1x, 2 sts. 1x, 1 st. 28x. (3 sts. 1x, 2 sts. 2x, 1 st. 28x). [3 sts. 2x, 2 sts. 1x, 1 st. 28x, 2 sts. 1x]. After Row 218 (226) [228], bind off the remaining sts.

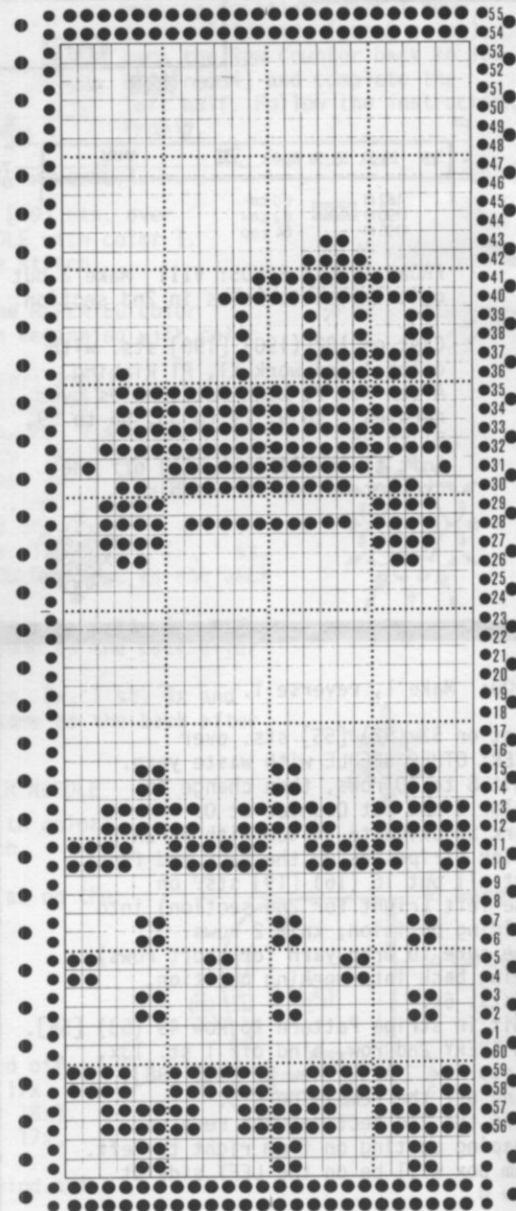

KK 400

BOY'S PULLOVER

SIZES: 8 (10) [12]
YARN: Binia
GRAMS:
 color 1 200 250 300
 color 2 50 100 100
 color 3 100 100 100
TENSION: 7 to 9
GAUGE: 14 sts. 18 rows = 5 cm (2")

Stockinette stitch with a Norwegian Border Design according to the Illustration. Punch your own Card. Bands are K1, P1 Ribbing.

FINISHING: See General Instructions.

BACK: II

Cast on 102 (108) [114] sts. with color 1 and work 24 rows K1, P1 Ribbing. Continue in Stockinette stitch. Knit to Row 66 (74) [78]. Work the Norwegian Design to Row 116 (124) [128], then continue in Stockinette stitch. Knit to Row 122 (130) [134]. **SHAPE ARMHOLE: ON EACH SIDE,** Bind off 3 sts. 1x, 2 sts. 1x, 1 st. 4x. (4 sts. 1x, 2 sts. 1x, 1 st. 4x). [4 sts. 1x, 2 sts. 1x, 1 st. 4x]. Knit to Row 176 (188) [192]. Bind off the center 12 sts., put the needles on the left into holding position and complete the right side first.

***SHAPE SHOULDER AND NECK AT THE SAME TIME.**

FOR SHOULDER, bind off 5 sts. 4x.

(6 sts. 3x, 4 sts. 1x). [6 sts. 3x, 7 sts. 1x].

FOR NECK, on all sizes, bind off 4 sts. 4x.

Move the Cam Box to the left side, turn the Row Counter back to 176 (188) [192] and complete the left half. Follow the instructions from *.

FRONT: I

Work the front the same as the back to Row 154 (166) [170]. Bind off the center 12 sts., put the needles on the left into holding position and complete the right side first.

***ON NECK SIDE,** for all sizes, bind off 3 sts. 2x, 2 sts. 2x, 1 st. 6x AND **SHAPE SHOULDER** same as the back after Row 176 (188) [192]. Move the Cam Box to the left side, turn the Row Counter back to 154 (166) [170] and complete the left half. Follow the instructions from *.

SLEEVES: III

Cast on 56 (62) [68] sts. with color 1 and work 24 rows K1, P1 Ribbing. Continue in Stockinette stitch.

ON EACH SIDE, increase 1 st. every 10th row 10x AND **AT THE SAME TIME,** after Row 76 (80) [86], continue in the Norwegian Design to Row 126 (130) [136].

Continue in Stockinette stitch. Knit to Row 132 (136) [142].

SHAPE CAP: ON EACH SIDE, bind off 3 sts. 1x, 2 sts. 3x, 1 st. 10x, 2 sts. 2x, 3 sts. 3x.

(3 sts. 2x, 2 sts. 3x, 1 st. 10x, 2 sts. 2x, 3 sts. 3x).

[4 sts. 1x, 3 sts. 1x, 2 sts. 3x, 1 st. 11x, 2 sts. 2x, 3 sts. 3x].

After Row 170 (176) [184], bind off the remaining sts.

COLLAR: VI

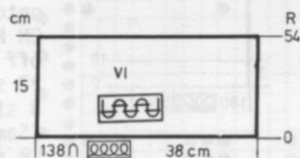
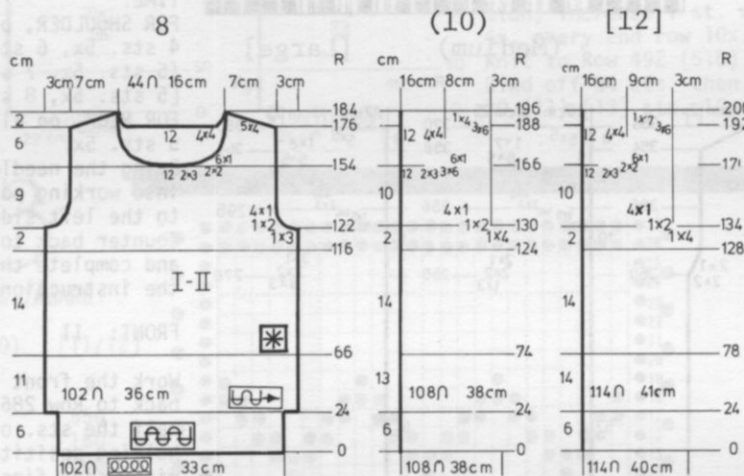

Cast on 138 sts. with color 1 and work 54 rows K1, P1 Ribbing then bind off the crochet method for Ribbing.

The Pattern Design covers 50 rows as follows:

- 6 rows color 1 & 2
- 2 rows color 1
- 6 rows color 1 & 3
- 2 rows 1
- 6 rows color 1 & 2
- 2 rows color 1
- 2 rows color 2
- 2 rows color 3
- 2 rows color 2
- 2 rows color 1
- 18 rows color 1 & 3

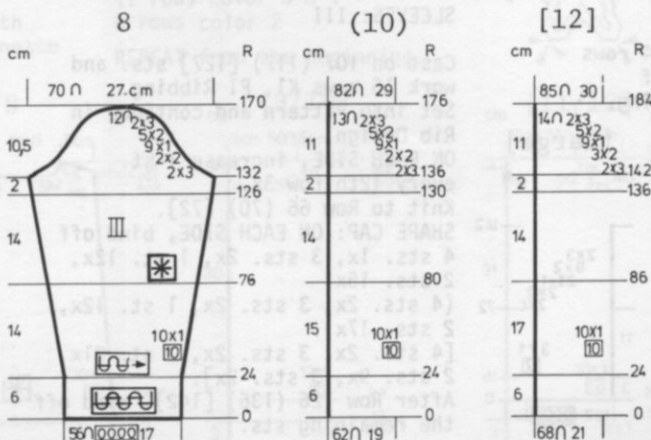

HP 402

MEN'S LONG JOHNS & SHIRT

SIZES: Small Medium Large
YARN: Fortissima
GRAMS:
 Pants 200 250 300
 Shirt 200 250 300
TENSION: 2 to 4
GAUGE: 18 sts. 25 rows = 5 cm (2")

A Ribbing Pattern that follows the Line Drawing. Bands are K1, P1 Ribbing.

FINISHING: See General Instructions.

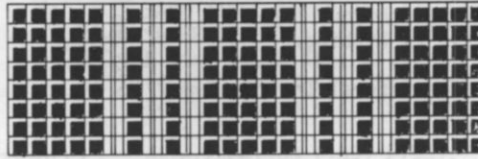

BACK: I

Cast on 132 (150) [180] sts. and work 18 rows K1, P1 Ribbing. Set up the Pattern according to the Line Drawing. Knit in Rib Pattern. Knit to Row 260 (260) [270]. **SHAPE ARMHOLE: ON EACH SIDE**, bind off 2 sts. 2x, 1 st. 2x. (3 sts. 1x, 2 sts. 2x, 1 st. 2x). [3 sts. 3x, 2 sts. 3x, 1 st. 3x]. Knit to Row 354 (358) [368]. Bind off the center 18 (18) [28] sts., put the needles on the left into holding position and complete the right side first.

*SHAPE SHOULDER AND NECK AT THE SAME TIME:

FOR SHOULDER, bind off 4 sts. 5x, 6 sts. 1x. (5 sts. 5x, 7 sts. 1x). [5 sts. 5x, 8 sts. 1x].

FOR NECK, on all sizes, bind off 5 sts. 5x. Bring the needles on the left into working position, knit 1 row to the left side, turn the Row Counter back to 354 (358) [368] and complete the left half. Follow the instructions from *.

FRONT: II

Work the front the same as the back to Row 286 (286) [296], put half the sts. on the left into holding position and complete the right side first (you will have to transfer the rib sts. to main machine before you can put the sts. into holding - or you can remove the sts. onto waste yarn).

ON NECK SIDE, on every other row, bind off

*7 sts. 1x, 5 sts. 1x, 4 sts. 1x, 3 sts. 2x, 2 sts. 2x, 1 st. 8x. (Same as first size).

[8 sts. 1x, 5 sts. 1x, 4 sts. 1x, 3 sts. 2x, 2 sts. 4x, 1 st. 8x].

SHAPE SHOULDER same as the back after Row 354 (358) [368].

Bring the needles on the left into working position, knit 1 row to the left side, turn the Row Counter back to 286 (286) [296] and complete the left half. Follow the instructions from *.

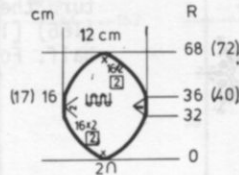
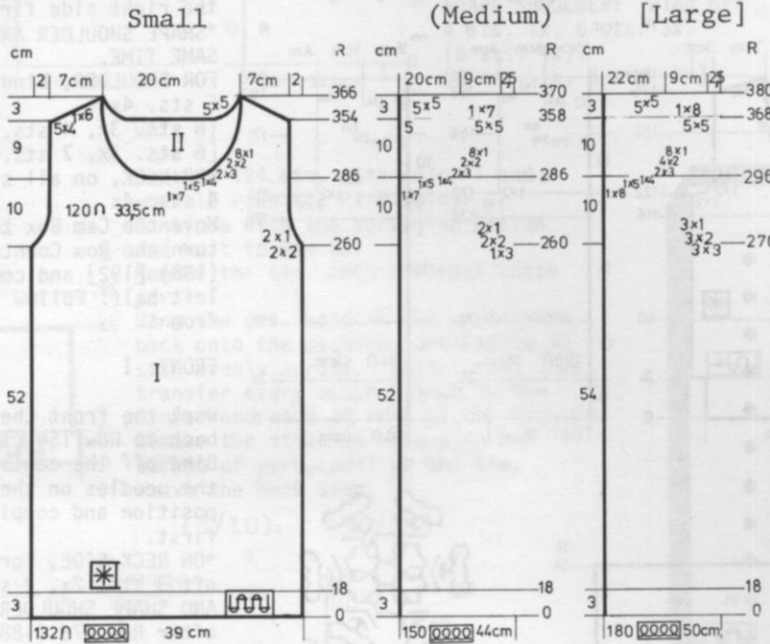

CROTCH:

Cast on 2 sts. and work Knit 1, P1 Ribbing.

ON EVERY 2nd row, ON EACH SIDE, cast on 2 sts. 16x.

Knit to Row 36 (40) [40].

ON EACH SIDE, ON EVERY 2nd row, bind off 2 sts. 16x.

After Row 68 (72) [72], bind off the remaining 2 sts.

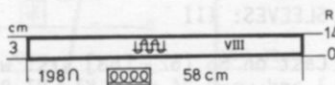

NECKBAND: VIII

Cast on 198 sts. and work 14 rows K1, P1 Ribbing then bind off the crochet method for Ribbing.

SLEEVES: III

Cast on 107 (117) [127] sts. and work 16 rows K1, P1 Ribbing. Set into Pattern and continue in Rib Design.

ON EACH SIDE, increase 1 st. every 12th row 3x.

Knit to Row 66 (70) [72].

SHAPE CAP: ON EACH SIDE, bind off 4 sts. 1x, 3 sts. 2x, 1 st. 12x, 2 sts. 15x.

(4 sts. 2x, 3 sts. 2x, 1 st. 12x, 2 sts. 17x).

[4 sts. 2x, 3 sts. 2x, 1 st. 21x, 2 sts. 9x, 3 sts. 2x].

After Row 126 (136) [142], bind off the remaining sts.

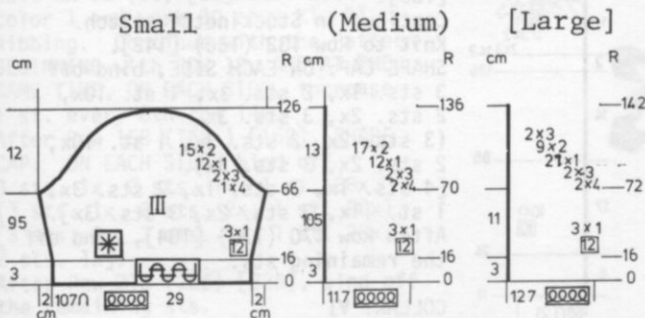

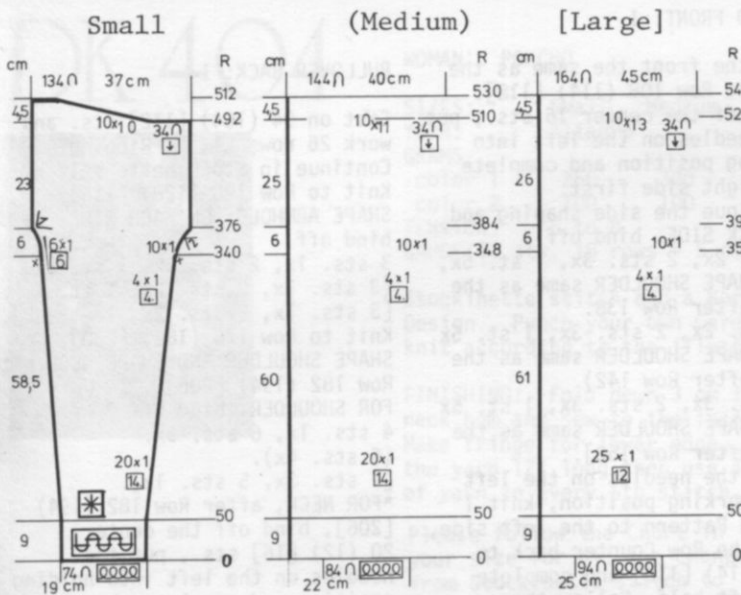

PANTS - Make 1, reverse 1.

Cast on 74 (84) [94] sts. and work 50 rows K1, P1 Ribbing. Set into Pattern and continue in Rib Design.

ON EACH SIDE, increase 1 st. every 14th row 20x (20x) [every 12th row 25x]. After Row 340 (348) [354], SHAPE CROTCH: ON THE LEFT (right for 2nd section) increase 1 st. every 6th row 6x and ON THE RIGHT (left for 2nd section) increase 1 st. every 4th row 4x, every 2nd row 10x. Knit to Row 492 (510) [520]. Bind off 34 sts. then bind off 10 (11) [13] sts. 10x.



KK 403

GIRL'S SKIRT, PULLOVER & TABARD

SIZES: 7/8 (9/10) [11/12]
 YARN: Allegro
 GRAMS: color 1 450 500 550
 color 2 100 150 150
 color 3 50 50 100
 TENSION: 7 to 9
 GAUGE: 13 sts. 19 rows = 5 cm (2")

Skirt and Pullover are in Stockinette stitch. The Tabard is a Norwegian Design. Punch your own card or follow the illustration.

FINISHING: See General Instructions. TABARD: Work 2 rows single crochet down the sides. Make cords and sew to each side for ties.

TABARD NECKBAND:

Cast on 120 (120) [124] sts. with color 2 and work 24 rows Stockinette stitch, then bind off.

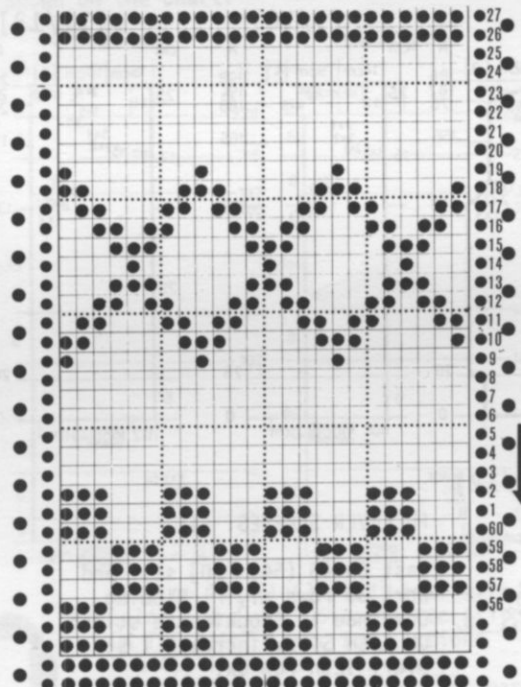

The Pattern is a REPEAT of 32 rows as follows:

- 9 rows color 2 & 3
- 6 rows color 2
- 11 rows color 3 & 1
- 6 rows color 2

REPEAT from the beginning.



TABARD BACK: II

Cast on 92 (102) 108] sts. with color 2 and work Stockinette stitch.

ON EACH SIDE, increase 1 st. after Row 6 and 12. Knit to Row 24. Continue in the Norwegian Design.

ON EACH SIDE, decrease 1 st. every 12th row 10x. (10th row 12x). [12th row 10x].

After Row 134 (140) [148], bind off the center 15 (15) [18] sts. put the needles on the left into holding position and complete the right side first.

*ON NECK SIDE for all sizes, bind off 2 sts. 5x BUT AT THE SAME TIME, SHAPE SHOULDER after Row 138 (142) [150]. FOR SHOULDER, bind off 4 sts. 2x, 5 sts. 1x. (4 sts. 4x). [4 sts. 3x, 6 sts. 1x].

Bring the needles on the left into working position, knit 1 row in Pattern to the left side, turn the Row Counter back to 134 (140) [148] and complete the left half. Follow the instructions from *.

7/8

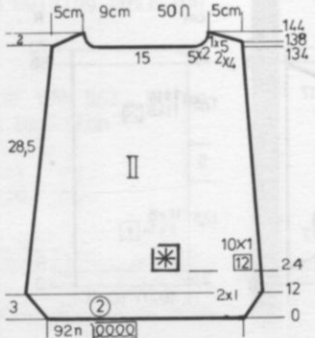

(9/10)

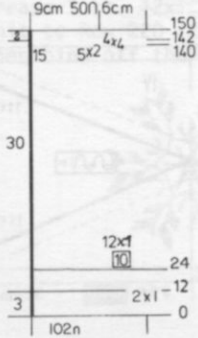

[11/12]

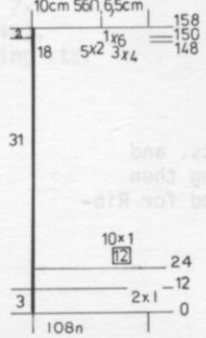

KK 403

TABARD FRONT: I

Work the front the same as the back to Row 108 (114) [118]. Bind off the center 16 sts., put the needles on the left into holding position and complete the right side first.
 *Continue the side shaping and ON NECK SIDE, bind off 3 sts. 2x, 2 sts. 3x, 1 st. 5x, and SHAPE SHOULDER same as the back after Row 138. (3 sts. 2x, 2 sts. 3x, 1 st. 5x and SHAPE SHOULDER same as the back after Row 142). [3 sts. 3x, 2 sts. 3x, 1 st. 5x and SHAPE SHOULDER same as the back after Row 150]. Bring the needles on the left into working position, knit 1 row in Pattern to the left side, turn the Row Counter back to 108 (114) [118] and complete the left half. Follow the instructions from *.

PULLOVER BACK: I

Cast on 94 (104) [112] sts. and work 26 rows K1, P1 Ribbing. Continue in Stockinette stitch. Knit to Row 120 (128) [136]. SHAPE ARMHOLE: ON EACH SIDE, bind off 3 sts. 1x, 2 sts. 2x, 1 st. 1x. (3 sts. 1x, 2 sts. 2x, 1 st. 3x) [3 sts. 1x, 2 sts. 2x, 1 st. 3x] Knit to Row 176 (188) [200]. SHAPE SHOULDER AND SHAPE NECK after Row 182 (194) [206]. FOR SHOULDER, bind off 4 sts. 1x, 6 sts. 3x. (6 sts. 4x). [7 sts. 3x, 5 sts. 1x]. *FOR NECK, after Row 182 (194) [206], bind off the center 20 (12) [16] sts., put the needles on the left into holding position and complete the right side first. ON NECK SIDE, bind off 3 sts. 1x, 2 sts. 2x. (4 sts. 3x). [4 sts. 3x]. Move the Cam Box to the left side, turn the Row Counter back to 182 (194) [206] and complete the left half. Follow the instructions from * and don't forget to complete the shoulder shaping.

PULLOVER FRONT: I

Work the front the same as the back to Row 156 (166) [176]. Divide in the center, put the needles on the left into holding position and complete the right side first.
 *ON NECK SIDE, bind off 5 sts. 1x, 3 sts. 2x, 2 sts. 2x, 1 st. 2x, and SHAPE SHOULDER same as the back after Row 176. (5 sts. 1x, 3 sts. 2x, 2 sts. 2x, 1 st. 3x, and SHAPE SHOULDER same as the back after Row 188). [7 sts. 1x, 3 sts. 2x, 2 sts. 2x, 1 st. 3x and SHAPE SHOULDER same as the back after Row 200]. Move the Cam Box to the left side, turn the Row Counter back to 156 (166) [176] and complete the left half. Follow the instructions from *.

PULLOVER SLEEVES: III

Cast on 48 (54) [60] sts. and work 30 rows K1, P1 Ribbing. Continue in Stockinette stitch. ON EACH SIDE, increase 1 st. every 12th row 9x. Knit to Row 148 (154) [160]. SHAPE CAP: ON EACH SIDE, bind off 3 sts. 2x, 2 sts. 1x, 1 st. 18x, 2 sts. 1x. (3 sts. 2x, 2 sts. 1x, 1 st. 18x, 2 sts. 2x). [3 sts. 2x, 2 sts. 1x, 1 st. 20x, 2 sts. 2x]. After Row 192 (200) [210], bind off the remaining sts.

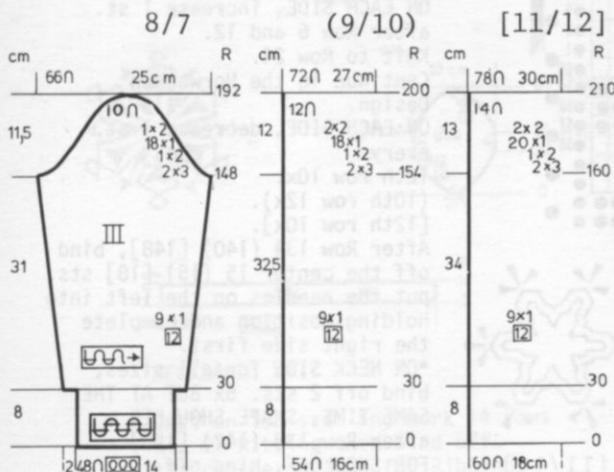
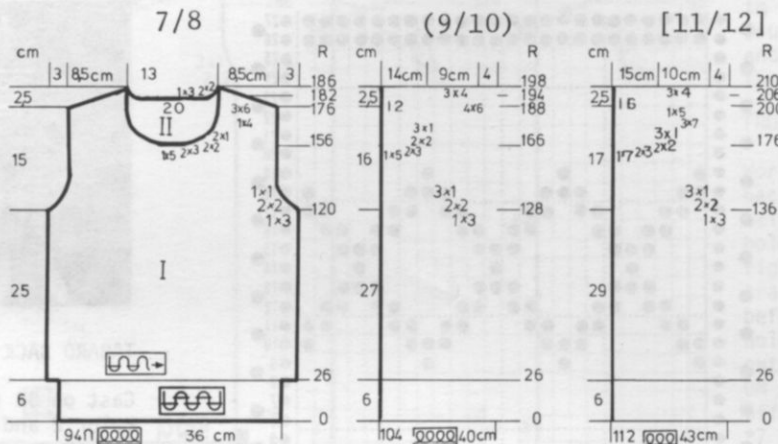
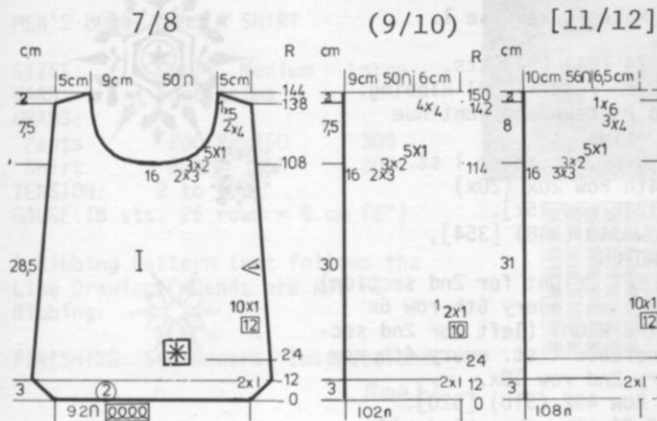

COLLAR:

Cast on 111 (111) [115] sts. and work 80 rows K1, P1 Ribbing then bind off the crochet method for Ribbing.

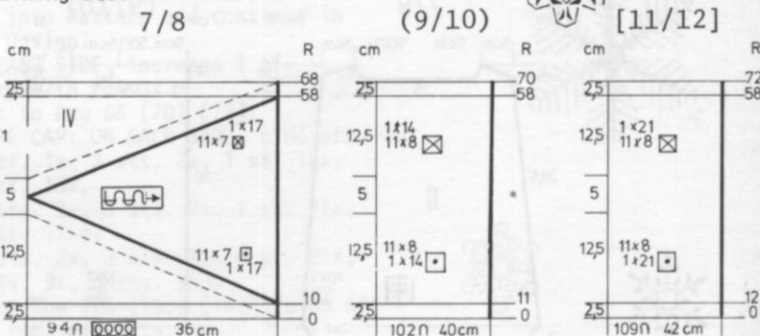

DK 404

WOMAN'S PONCHO



SIZES: Small Medium Large
 YARN: Allegro
 GRAMS: color 1 250 300 300
 color 2 100 100 100
 TENSION: 6 to 8
 GAUGE: 14 sts. 18 rows = 5 cm (2")



Stockinette stitch and a Norwegian Design. Punch your own Card or knit according to the illustration.

FINISHING: Fold down 3 cm for neck hem and sew to the inside. Make fringe for lower edge, cutting the yarn 12" long then use 4 strands of yarn in every 5th stitch.

Please follow the Chart in your size for all the changes from Stockinette stitch to the Norwegian Designs, knitting the correct number of rows between as shown on the Chart.

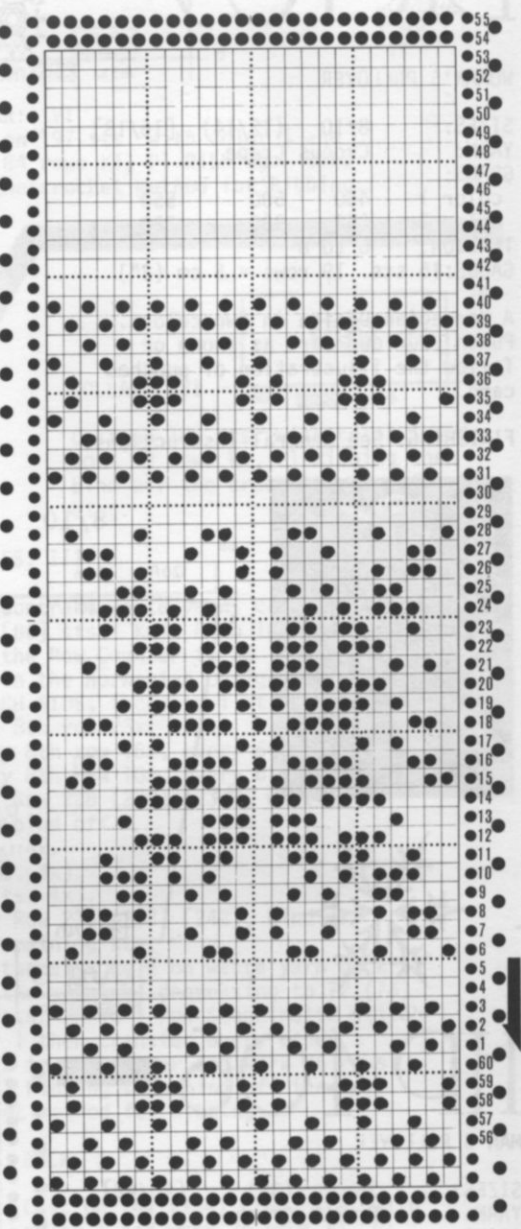
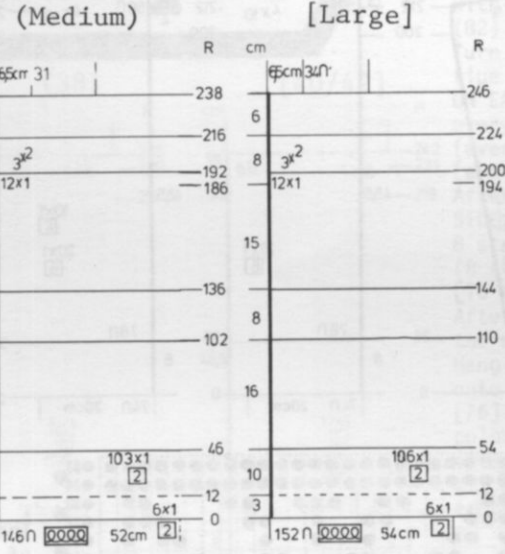
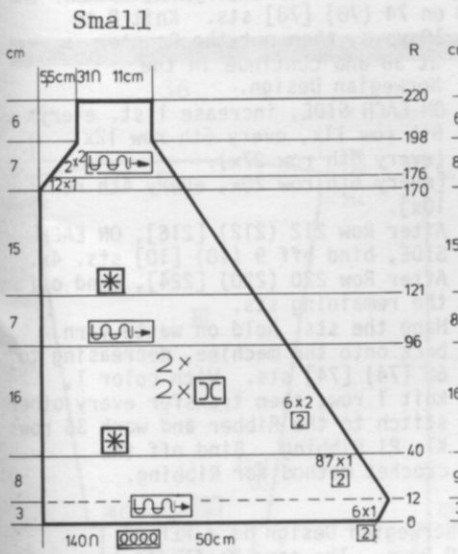

SKIRT: IV

With contrast waste yarn, cast on 94 sts (102) [109] sts. and work Stockinette stitch. Knit 8 to 10 rows, change to garment yarn and put Counter at 0.
 *Knit 10 rows, then work SHORT ROWS. ON OPPOSITE SIDE OF CAM BOX, put into holding position
 17 (14) [21] sts. then on every 2nd row, put into holding position 7 sts. 11x (8 sts. 11x) [8 sts. 11x].
 ON OPPOSITE SIDE OF CAM BOX, bring back into working position 7 sts. 11x, 17 sts. 1x. (8 sts. 11x, 14 sts. 1x). [8 sts. 11x, 21 sts. 1x].
 Knit 10 rows.
 REPEAT from * 10x more.
 Remove the sts. onto contrast waste yarn. Weave the open sts. together then remove the waste yarn.

Cast on 140 (146) [152] sts. with color 1 and work Stockinette stitch. ON THE RIGHT (left for sections 3 & 4), increase 1 st. every 2nd row 6x. After Row 12, decrease 1 st. every 2nd row 87x, then 2 sts. 6x (1 st. every 2nd row 103x) [1 st. every 2nd row 106x] BUT AT THE SAME TIME, after Row 24, HANG THE HEM. Continue to follow the Chart for your size and after Row 169 (185) [193], on the LEFT (right for sections 3 & 4), decrease 1 st. 12x, 2 sts. 2x. Knit to Row 220 (238) [246], then bind off the remaining sts.



DK 405

WOMAN'S PULLOVER

SIZES: 8/10 (12/14) [16/18]
 YARN: Crocus Crepe
 GRAMS:
 color 1 450 500 550
 color 2 250 300 350
 TENSION: 6 to 8
 GAUGE: 15 sts. 19 rows = 5 cm (2")

A Norwegian Design in two colors.
 Punch your own card as shown or follow the illustration of punched card.

FINISHING: See General Instructions.

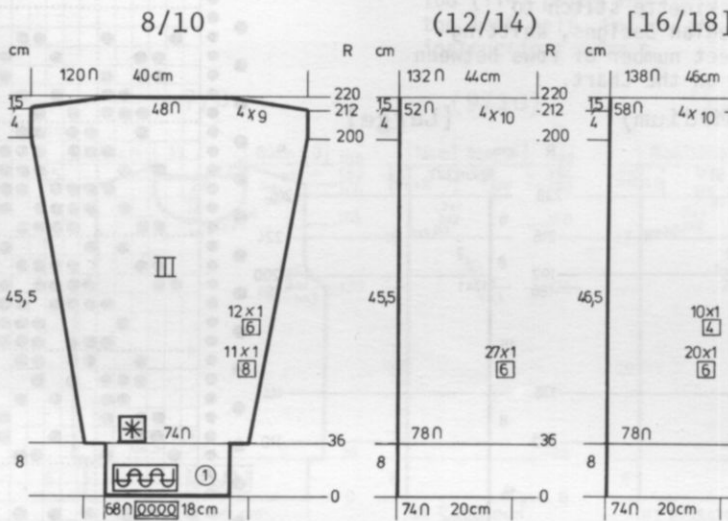
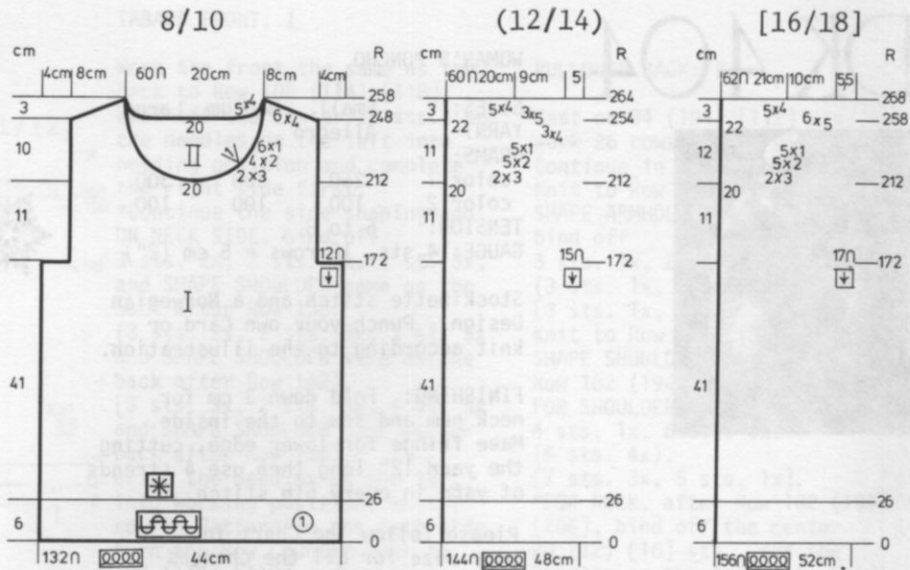

SLEEVES: III

With contrast waste yarn, cast on 74 (78) [78] sts. Knit 8 to 10 rows, then put the Counter at 36 and continue in the Norwegian Design.
 ON EACH SIDE, increase 1 st. every 8th row 11x, every 6th row 12x. (every 6th row 27x). [every 6th row 20x, every 4th row 10x].
 After Row 212 (212) [216], ON EACH SIDE, bind off 9 (10) [10] sts. 4x. After Row 220 (220) [224], bind off the remaining sts.
 Hang the sts. held on waste yarn back onto the machine, decreasing to 68 (74) [74] sts. With color 1, knit 1 row, then transfer every other stitch to the Ribber and work 36 rows K1, P1 Ribbing. Bind off the crochet method for Ribbing.

HP 406

MAN'S PULLOVER

SIZES: 36 (38) [40/42]
 YARN: Crocus Crepe
 GRAMS:
 color 1 500 550 600
 color 2 350 400 450
 TENSION: 7 to 8
 GAUGE: 15 sts. 19 rows = 5 cm (2")

A Norwegian Design. Use the same Punch Card as for DK 405 or follow the Punch Card illustration.
 Bands and Collar are K1, P1 Ribbing.

FINISHING: See General Instructions.

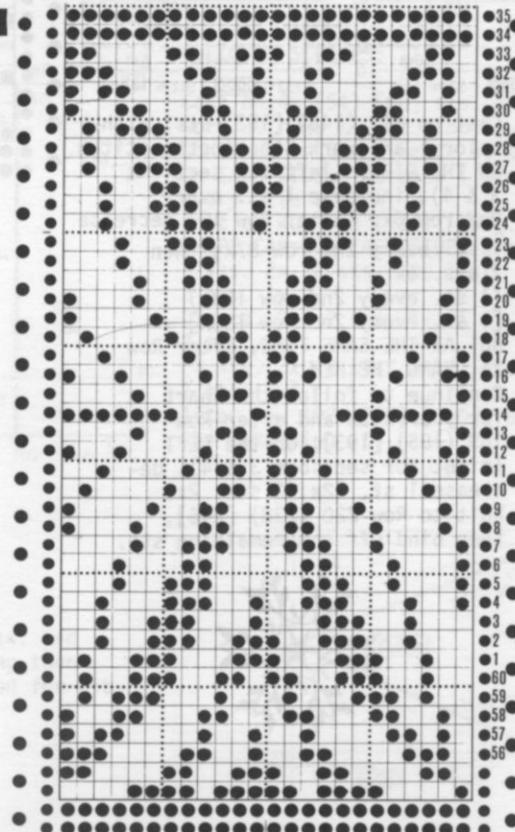
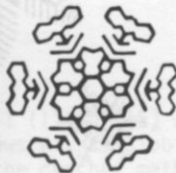

The Norwegian Design is a REPEAT of 40 Rows. The same design to be used for HP 405.

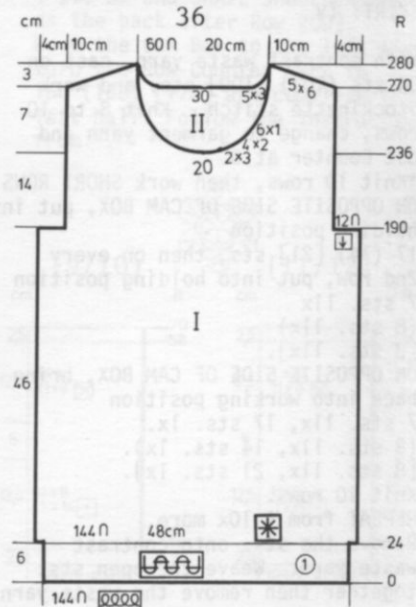

BACK: II

FRONT: I

Cast on 132 (144) [156] sts. with color 1 and work 26 rows K1, P1 Ribbing.
 Continue in the Norwegian Design.
 Knit to Row 172.
 ON EACH SIDE, bind off 12 (15) [17] sts.
 Knit to Row 248 (254) [258].
 Bind off the center 20 (20) [22] sts., put the needles on the left into holding position and complete the right side first.
 *SHAPE SHOULDER AND NECK AT THE SAME TIME.
 FOR SHOULDER, bind off 4 sts. 6x.
 (4 sts. 3x, 5 sts. 3x).
 [5 sts. 6x].
 FOR NECK, on all sizes, bind off 4 sts. 5x.
 Bring the needles on the left into working position, knit 1 row in Pattern to the left side, turn the Row Counter back to 248 (254) [258] and complete the left half. Follow the instructions from *.

Work the front the same as the back to Row 212.
 Bind off the center 20 sts., put the needles on the left into holding position and complete the right side first.
 *ON NECK SIDE, bind off 3 sts. 2x, 2 sts. 4x, 1 st. 6x.
 (3 sts. 2x, 2 sts. 4x, 1 st. 6x).
 [3 sts. 2x, 2 sts. 5x, 1 st. 5x].
 After Row 248 (254) [258], SHAPE SHOULDER same as the back.
 Bring the needles on the left into working position, knit 1 row in Pattern to the left side, turn the Row Counter back to 212 and complete the left half. Follow the instructions from *.

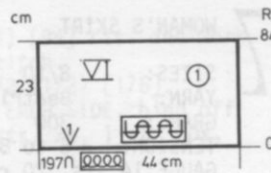

COLLAR: VI
 Cast on 197 sts. with color 1 and work 84 rows K1, P1 Ribbing. Bind off the crochet method for Ribbing.

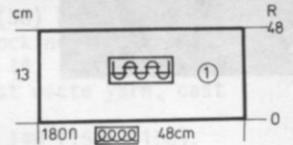

COLLAR: VI
 Cast on 180 sts. with color 1 and work 48 rows K1, P1 Ribbing then bind off the crochet method for Ribbing.

SLEEVES: III

With contrast waste yarn, cast on 78 (82) [86] sts. Knit 8 to 10 rows. Turn the Row Counter to 36 and continue in the Norwegian Design.
 ON EACH SIDE, increase 1 st. every 8th row 23x.
 (every 8th row 15x, every 6th row 8x).
 [every 8th row 10x, every 6th row 17x].
 After Row 228 (230) [234], ON EACH SIDE, bind off 8 sts. 4x.
 (8 sts. 4x).
 [10 sts. 4x].
 After Row 236 (238) [242], bind off the remaining sts.
 Hang the sts. held on waste yarn back onto the machine, decreasing to 72 (76) [76] sts. Knit 1 row Stockinette stitch color 1 then transfer every other stitch to the Ribber and work 36 rows K1, P1 Ribbing then bind off the crochet method for Ribbing.

BACK: I

Cast on 144 (154) [166] sts. with color 1 and work 24 rows K1, P1 Ribbing.
 Continue in the Norwegian Design.
 Knit to Row 190.
 ON EACH SIDE, bind off 12 (15) [15] sts. Knit to Row 270 (274) [278]. Bind off the center 30 (30) [26] sts., put the needles on the left into holding position and complete the right side first.
 *SHAPE SHOULDER AND NECK AT THE SAME TIME.
 FOR SHOULDER, bind off 6 sts. 5x.
 (6 sts. 4x, 8 sts. 1x).
 [7 sts. 5x].
 FOR NECK, bind off 3 sts. 5x.
 (3 sts. 5x).
 [4 sts. 5x].
 Bring the needles on the left into working position, knit 1 row in Pattern to the left side, turn the Row Counter back to 270 (274) [278] and complete the left half. Follow the instructions from *.

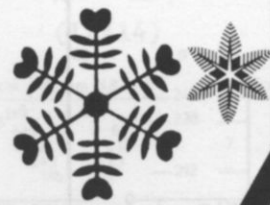
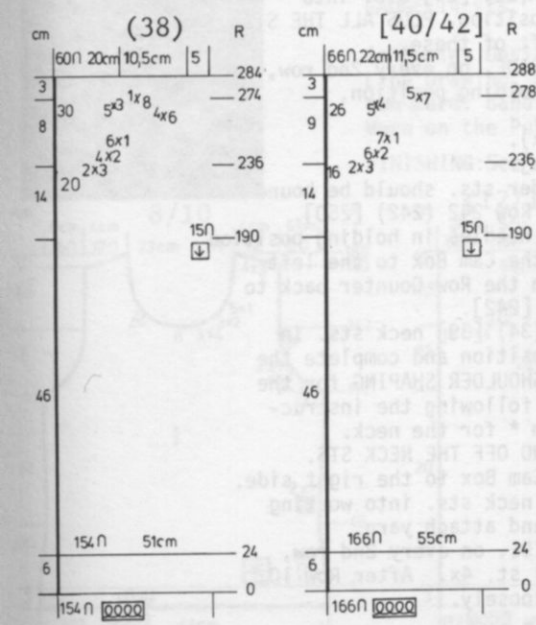
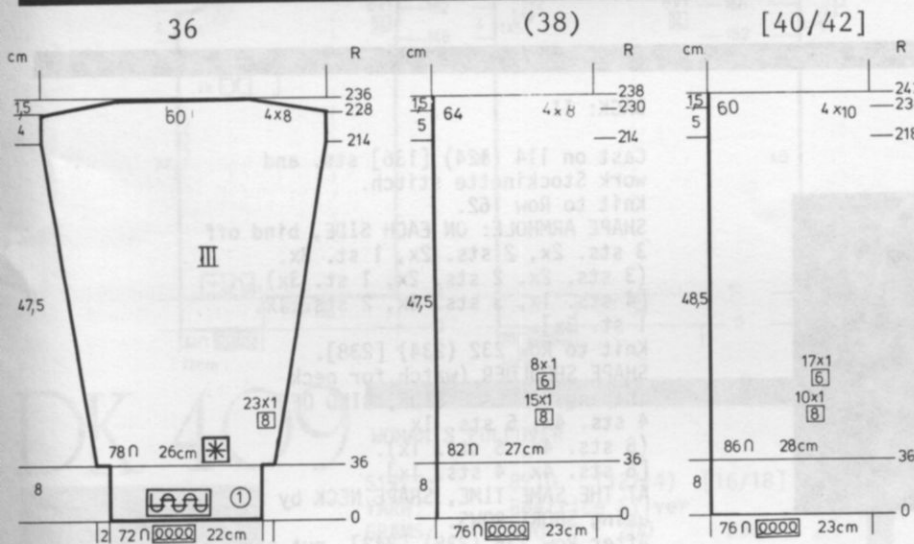

FRONT: I
 Work the front the same as the back to Row 236.
 Bind off the center 20 (20) [16] sts. put the needles on the left into holding position and complete the right side first.
 *ON NECK SIDE, bind off 3 sts. 2x, 2 sts. 4x, 1 st. 6x.
 (3 sts. 2x, 2 sts. 4x, 1 st. 6x).
 [3 sts. 2x, 2 sts. 6x, 1 st. 7x].
 SHAPE SHOULDER same as the back after Row 270 (274) [278].
 Bring the needles on the left into working position, knit 1 row in Pattern to the left side, turn the Row Counter back to 236 and complete the left half. Follow the instructions from *.

DK 407

WOMAN'S SKIRT

SIZES: 8/10 (12/14) [16/18]
 YARN: Beatrice Silver
 GRAMS: 300 350 400
 TENSION: 6 to 8
 GAUGE: 14 sts. 20 rows = 5 cm (2")



Stockinette stitch. Purl side.

FINISHING: See General Instructions.

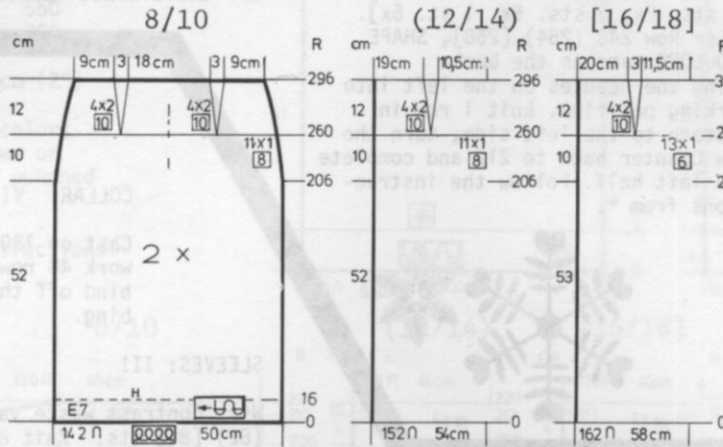

FRONT & BACK: I II

Cast on 142 (152) [162] sts. and work Stockinette stitch. Lower the tension 1 number to Row 16, then continue in garment tension. Knit to Row 206 (206) [210]. ON EACH SIDE, decrease 1 st. every 8th row 11x (watch for darts. (every 8th row 11x) watch for darts. [every 6th row 13x] watch for darts. AT THE SAME TIME, after Row 260 (260) [264], decrease 2 sts. for EACH DART every 10th row 4x. For the first dart decrease, ON EACH SIDE, hang the 29th & 31st sts. onto the 30th needle. (31st & 33rd onto 32nd needle). [32nd & 34th onto 33rd needle]. Move the sts. in to fill the empty needles. The following dart decreases lie directly above. After Row 296 (296) [300], bind off the remaining sts.

DK 408

WOMAN'S JACKET

SIZES: 8/10 (12/14) [16/18]
 YARN: Beatrice Silver
 GRAMS: 400 450 500
 TENSION: 7 to 9
 GAUGE: 13 sts. 18 rows = 5 cm (2")

Stockinette stitch worn on the Purl side.

FINISHING: See General Instructions.



BACK: II

Cast on 114 (124) [136] sts. and work Stockinette stitch. Knit to Row 162. SHAPE ARMHOLE: ON EACH SIDE, bind off 3 sts. 2x, 2 sts. 2x, 1 st. 3x. (3 sts. 2x, 2 sts. 2x, 1 st. 3x). [4 sts. 1x, 3 sts. 2x, 2 sts. 1x, 1 st. 3x]. Knit to Row 232 (234) [238]. SHAPE SHOULDER (watch for neck shaping). ON EACH SIDE, BIND OFF 4 sts. 4x, 5 sts. 1x. (5 sts. 4x, 6 sts. 1x). [6 sts. 4x, 4 sts. 1x]. AT THE SAME TIME, SHAPE NECK by using SHORT ROWS. After Row 236 (238) [242], put the center 22 (22) [24] sts. into holding position, PLUS ALL THE STS. to the left of these. *ON NECK SIDE, on every 2nd row, put into holding position, 4 sts. 3x. (4 sts. 3x). [5 sts. 3x]. The shoulder sts. should be bound off after Row 242 (242) [250]. Leave the needles in holding position and move the Cam Box to the left side, turn the Row Counter back to 236 (238) [242]. Leave 34 (34) [39] neck sts. in holding position and complete the NECK AND SHOULDER SHAPING for the left half following the instructions from * for the neck. DO NOT BIND OFF THE NECK STS. Move the Cam Box to the right side. Bring the neck sts. into working position and attach yarn. ON EACH SIDE, on every 2nd row, increase 1 st. 4x. After Row 10, bind off loosely.

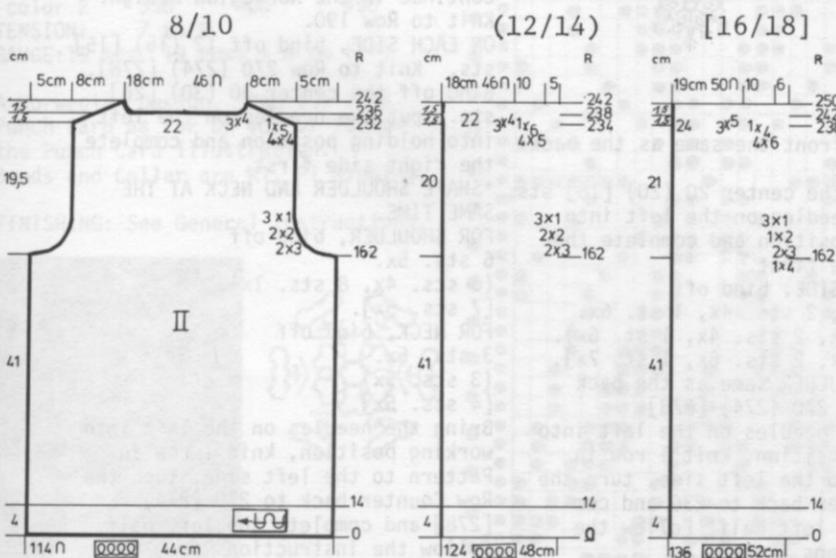

8/10

(12/14)

[16/18]

SLEEVE: III

Cast on 88 (94) [94] sts. and work Stockinette stitch.
 Knit to Row 172 (172) [176].
 SHAPE CAP: ON EACH SIDE, bind off 3 sts. 2x, 2 sts. 2x, 1 st. 20x, 2 sts. 3x.
 (3 sts. 2x, 2 sts. 2x, 1 st. 19x, 2 sts. 5x).
 [4 sts. 1x, 3 sts. 1x, 1 st. 20x, 2 sts. 5x].
 After Row 226 (228) [234], bind off the remaining sts.

FRONT: I Make 1, reverse 1

Cast on 32 (38) [43] sts. and work Stockinette stitch.
 Knit to Row 14.
 With contrast waste yarn, cast on 52 sts.
 Knit to Row 148 (152) [158].
 ON FRONT EDGE, increase 1 st. every 14th row 6x AND AT THE SAME TIME, after Row 163 (167) [173], SHAPE ARMHOLE: Bind off 4 sts. 1x, 3 sts. 1x, 2 sts. 3x, 1 st. 3x.
 (5 sts. 1x, 3 sts. 1x, 2 sts. 3x, 1 st. 3x).
 [5 sts. 1x, 3 sts. 1x, 2 sts. 3x, 1 st. 4x].

ON ARM SIDE, increase 1 st. every 8th row 3x.
 After Row 206 (212) [218], put 45 (50) [54] sts. on the LEFT (right for 2nd section) into holding position and complete the right (left) side first.
 ON NECK SIDE, bind off 6 sts. 1x, 3 sts. 2x, 2 sts. 3x, 1 st. 6x.
 (same as first size).
 [8 sts. 1x, 3 sts. 2x, 2 sts. 3x, 1 st. 6x].

After Row 242 (248) [258], bind off the remaining sts.
 Move the Cam Box to the left side, turn the Row Counter back to 206 (212) [218] and complete the left half (right for 2nd section).
 ON NECK SIDE, make the bind offs the same as other side and after Row 233 (237) [247] SHAPE SHOULDER same as the back.

FRONT: I

Work the front the same as the back to Row 142 (148) [154].
 Put half the sts. on the left into holding position and complete the right side first.

*ON NECK SIDE, on every 2nd row, bind off 8 sts. 1x, 4 sts. 3x, 2 sts. 3x, 1 st. 5x.
 (10 sts. 1x, 4 sts. 3x, 2 sts. 3x, 1 st. 5x).
 [10 sts. 1x, 4 sts. 3x, 2 sts. 4x, 1 st. 5x].
 After Row 180 (186) [192], SHAPE SHOULDER same as the back.
 Bring the needles on the left into working position, knit 1 row in Pattern to the left side, turn the Row Counter back to 142 (148) [154] and complete the left half.
 Follow the instructions from *.



Continued

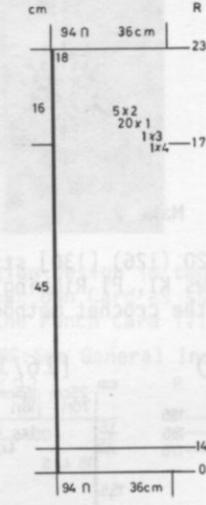
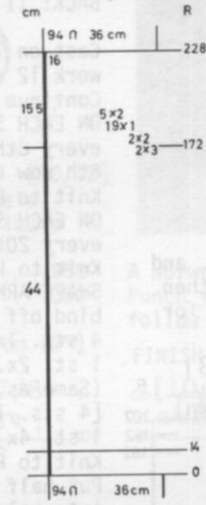
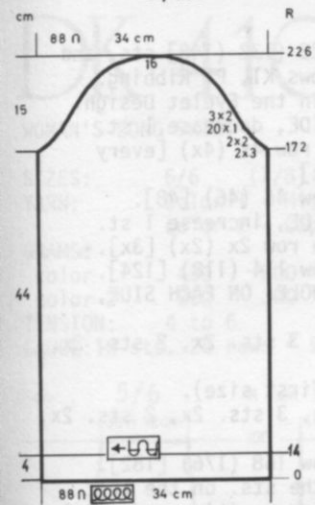

8/10

(12/14)

[16/18]

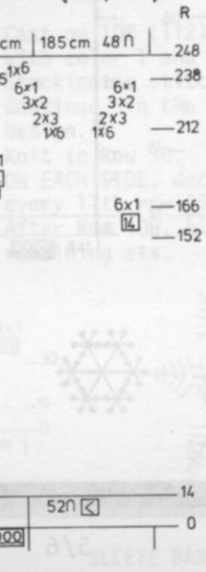
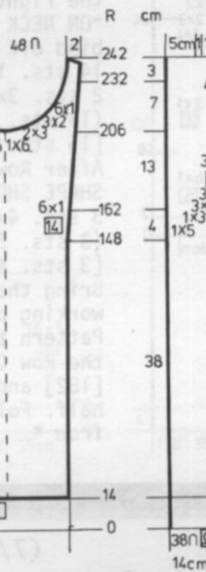
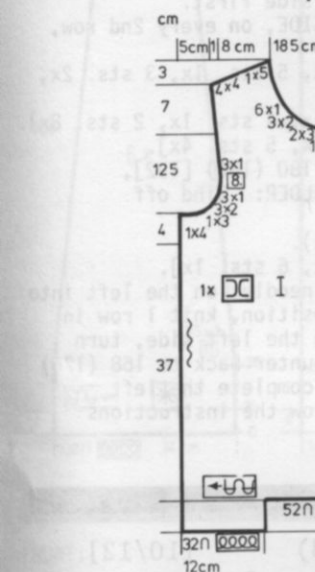

DK 409

WOMAN'S PULLOVER

SIZES: 8/10 (12/14) [16/18]
 YARN: Beatrice Silver
 GRAMS: 200 200 250
 TENSION: 6 to 8
 GAUGE: 14 sts. 18 rows = 5 cm (2")

An Eyelet Design that follows the Line Drawing, or you can punch your own card. Bands are ribbed. Worn on the Purl side.

FINISHING: See General Instructions.

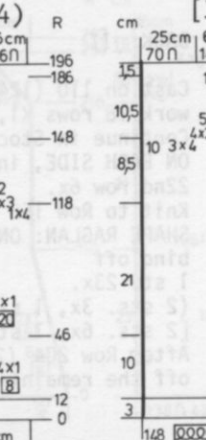
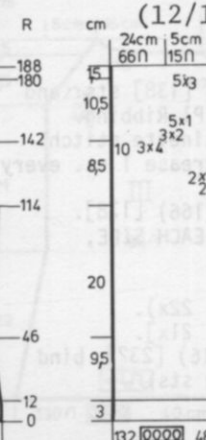
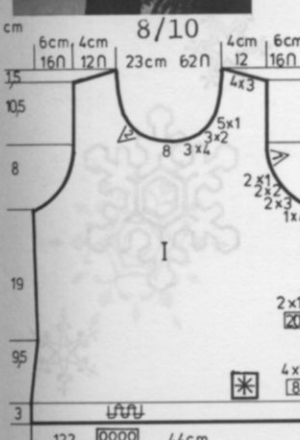

DK 409

BACK: II

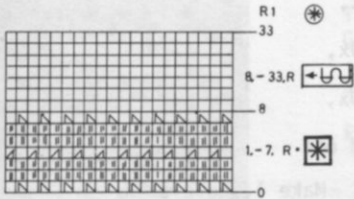

ARBANDS: Make 2.

Cast on 120 (126) [130] sts. and work 8 rows K1, P1 Ribbing then bind off the crochet method for Ribbing.

Cast on 122 (132) [148] sts. and work 12 rows K1, P1 Ribbing. Continue in the Eyelet Design. ON EACH SIDE, decrease 1 st. every 8th row 4x (4x) [every 6th row 6x].

Knit to Row 46 (46) [48]. ON EACH SIDE, increase 1 st. every 20th row 2x (2x) [3x]. Knit to Row 114 (118) [124]. SHAPE ARMHOLE: ON EACH SIDE, bind off 4 sts. 1x, 3 sts. 2x, 2 sts. 2x, 1 st. 2x.

(Same as first size). [4 sts. 1x, 3 sts. 2x, 2 sts. 2x, 1 st. 4x].

Knit to Row 168 (176) [182]. Put half the sts. on the left into holding position and complete the right side first.

*ON NECK SIDE, on every 2nd row, bind off 14 sts. 1x, 5 sts. 1x, 3 sts. 2x, 2 sts. 3x.

(13 sts. 1x, 4 sts. 1x, 2 sts. 8x). [15 sts. 1x, 5 sts. 4x].

After Row 180 (186) [192], SHAPE SHOULDER: Bind off 3 sts. 4x.

(3 sts. 5x). [3 sts. 4x, 6 sts. 1x].

Bring the needles on the left into working position, knit 1 row in Pattern to the left side, turn the Row Counter back to 168 (176) [182] and complete the left half. Follow the instructions from *.

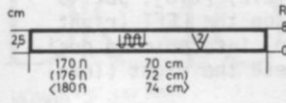
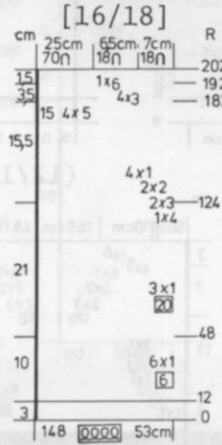
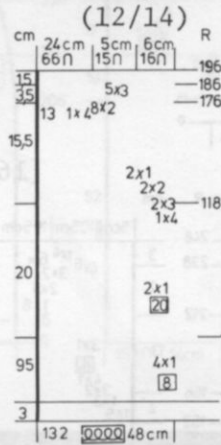
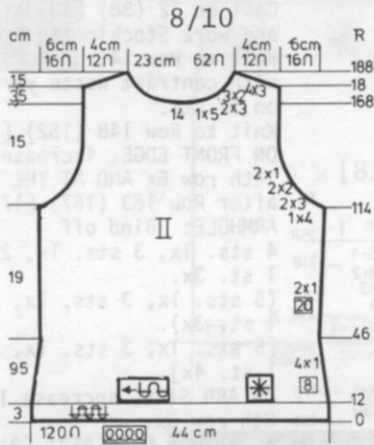

NECKBAND: Cast on 170 (176) [180] sts. and work 8 rows K1, P1 Ribbing then bind off the crochet method for Ribbing.



DK 411

WOMAN'S BLOUSE

SIZES: 5/6 (7/8) [10/12]
 YARN: Capriccio
 GRAMS: 200 250 250
 TENSION: 3 to 5
 GAUGE: 16 sts. 25 rows = 5 cm (2")

Stockinette stitch worn on the Purl side. The bands are K1, P1 Ribbing.

FINISHING: See General Instructions.

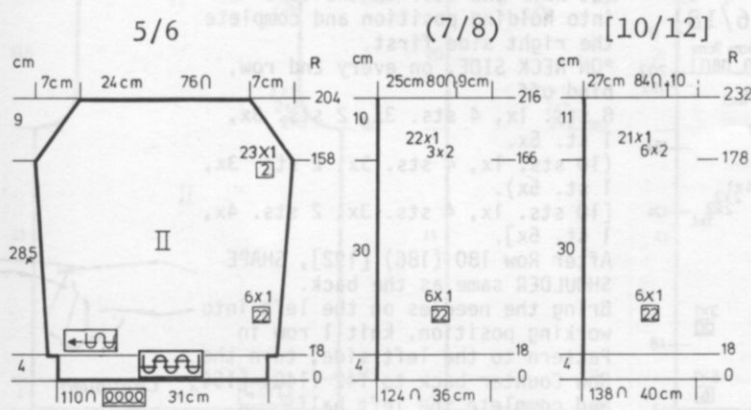
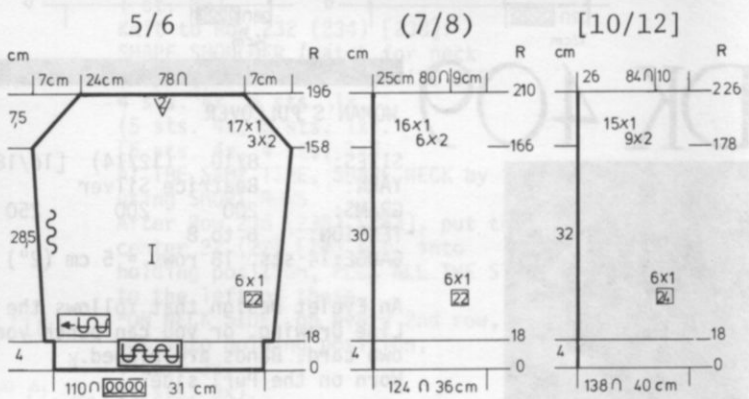

BACK: II
 Cast on 110 (124) [138] sts. and work 18 rows K1, P1 Ribbing. Continue in Stockinette stitch. ON EACH SIDE, increase 1 st. every 22nd row 6x. Knit to Row 158 (166) [178]. SHAPE RAGLAN: ON EACH SIDE, bind off 1 st. 23x. (2 sts. 3x, 1 st. 22x). [2 sts. 6x, 1 st. 21x]. After Row 204 (216) [232], bind off the remaining sts.



DK 410

WOMAN'S LONG SKIRT

SIZES: 5/6 (7/8) [10/12]
 YARN: Color 1 - Micaela
 Color 2 - Capriccio

GRAMS:
 color 1 450 500 550
 color 2 250 300 350
 TENSION: 4 to 6
 GAUGE: 16 sts. 25 rows = 5 cm (2")



A Norwegian Design in two colors.
 Punch your own Card as shown or
 follow the Punch Card illustration.
 FINISHING: See General Instructions.

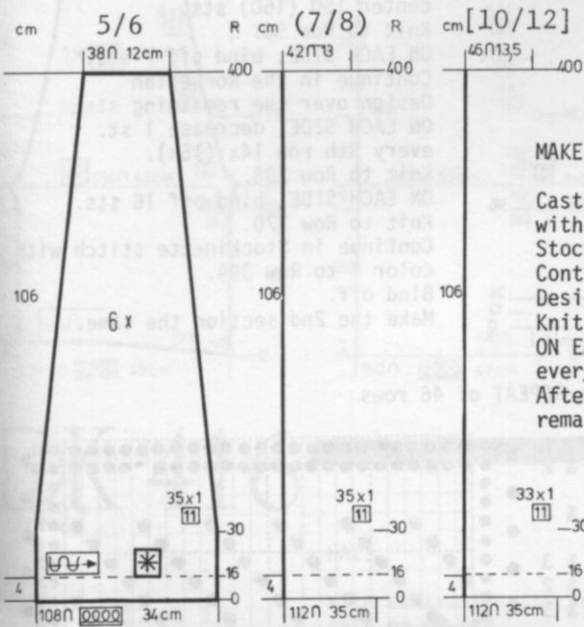
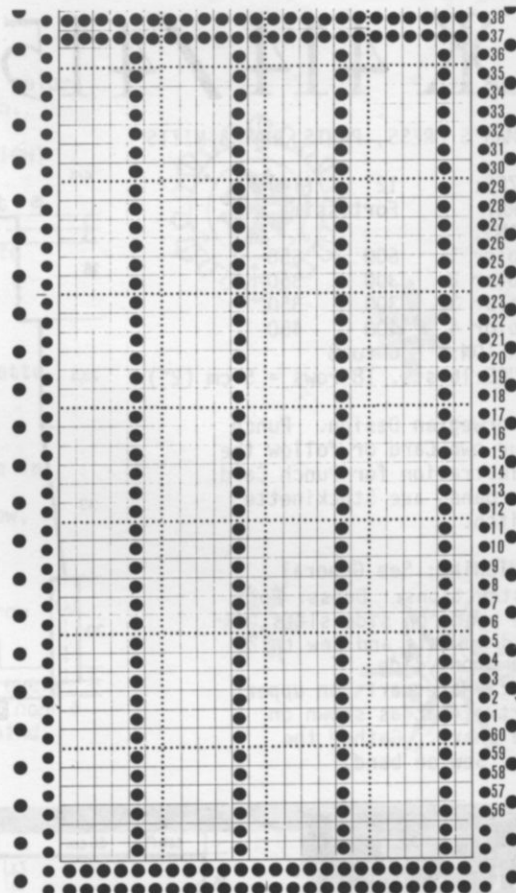

MAKE 6 sections.

Cast on 108 (112) [112] sts.
 with color 1 and work 16 rows
 Stockinette stitch.
 Continue in the Norwegian
 Design.
 Knit to Row 30.
 ON EACH SIDE, decrease 1 st.
 every 11th row 35x (35x) [33x].
 After Row 400, bind off the
 remaining sts.



FRONT: I

Work the front the same as the
 back to Row 158 (166) [178].
 SHAPE RAGLAN: ON EACH SIDE
 bind off
 2 sts. 3x, 1 st. 17x.
 (2 sts. 6x, 1 st. 16x).
 [2 sts. 9x, 1 st. 15x].
 After Row 196 (210) [226], bind
 off the remaining sts.

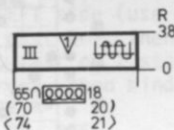

NECKBAND:

Cast on 150 (154) [154] sts. and
 work 9 rows K1, P1 Ribbing, then
 bind off the crochet method for
 Ribbing.

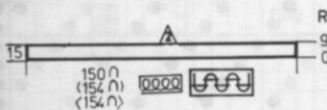

SLEEVE BANDS:

Hang the sts. of the sleeve back
 onto machine, decreasing to
 65 (70) [74] sts. Remove the
 waste yarn, transfer every other
 stitch to the Ribber and work
 38 rows K1, P1 Ribbing then
 bind off the crochet method for Rib-
 bing.

SLEEVES: III Make 1, reverse 1.

With contrast waste yarn,
 cast on 130 (138) [142] sts.
 Knit 8 to 10 rows, then change
 to garment yarn and put Counter
 at 0.

Work Stockinette stitch.
 ON EACH SIDE, decrease
 1 st. every 8th row 6x,
 every 6th row 10x.
 Knit to Row 216 (222) [222].
 SHAPE RAGLAN: ON FRONT SIDE,
 decrease

2 sts. 3x, 1 st. 17x.
 (2 sts. 3x, 1 st. 19x).
 [2 sts. 1x, 1 st. 23x].
 AND ON BACK SIDE, decrease
 1 st. 23x.
 (2 sts. 3x, 1 st. 22x).
 [1 st. 28x].

AT THE SAME TIME, after
 Row 253 (265) [269], work
 SHORT ROWS: ON OPPOSITE
 SIDE OF CAM BOX, put
 into holding position
 14 (21) [27] sts. 1x,
 then 8 sts. 4x for all
 sizes.
 After Row 262 (272) [278]
 bind off loosely.

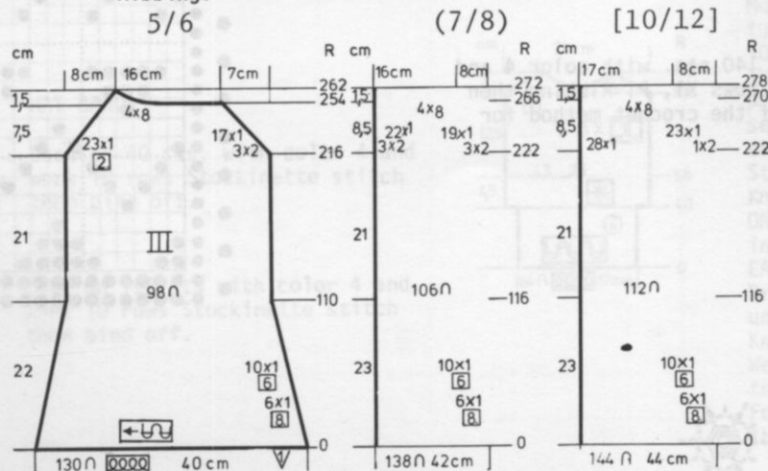

DK 414 / 415 / 416

WOMAN'S DRESS, PANTS, HAT & MITTS

SIZES: 12 (14)
YARN: Fortissima
GRAMS:
 color 1 600 650
 color 2 300 350
 color 3 300 350
 color 4 400 450
TENSION: 6 to 8
GAUGE: 16 sts. 18 rows = 5 cm (2")

A Norwegian Design. Punch your own Card or follow the illustration for Punch Card. The bands are Stockinette stitch.

FINISHING: See General instructions. Dress: For the bands on side slits, fold in half and sew to the wrong side. Hat: Make darts on upper part of hat as shown on the Chart. Gather the top. Sew on band.

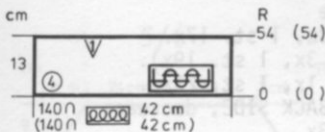

CUFFS:

Cast on 140 sts. with color 4 and work 54 rows K1, P1 Ribbing then bind off the crochet method for Ribbing.

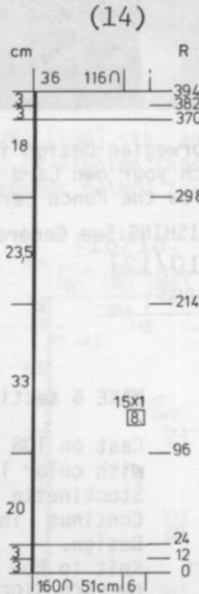
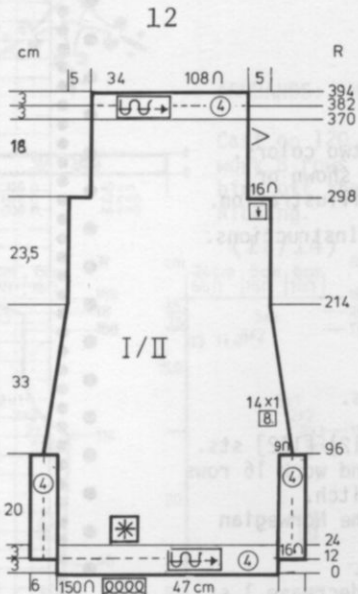

DRESS FRONT/BACK I II

Cast on 150 (160) sts. with color 4 and work Stockinette stitch. After Row 12, cast on 16 sts. ON EACH SIDE (use a separate yarn for the left side). Knit to Row 24. Keeping the 16 sts. ON EACH SIDE, in Stockinette stitch with color 4, continue in the Norwegian Design over the center 150 (160) sts. Knit to Row 96. ON EACH SIDE, bind off 7 sts. Continue in the Norwegian Design over the remaining sts. ON EACH SIDE, decrease 1 st. every 8th row 14x (15x). Knit to Row 298. ON EACH SIDE, bind off 16 sts. Knit to Row 370. Continue in Stockinette stitch with color 4 to Row 394. Bind off. Make the 2nd section the same.

The Pattern is a REPEAT of 46 rows as follows:

- 11 Rows color 1 & 2
- 2 Rows color 1
- 8 Rows color 1 & 4
- 2 Rows color 2
- 3 Rows color 1 & 3
- 5 Rows color 1 & 2
- 3 Rows color 1 & 3
- 2 Rows color 1
- 8 Rows color 1 & 4
- 2 Rows color 1

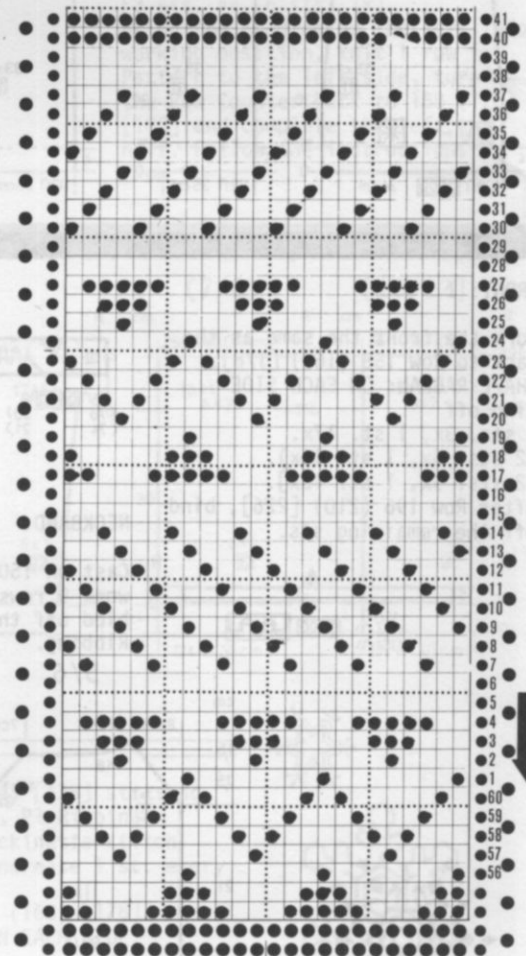

SLEEVES: III

Cast on 148 sts. with color 1 and work the Norwegian Design. ON CAM BOX side, increase 1 st. every 4th row 7x, every 6th row 5x. Knit to Row 90. ON CAM BOX SIDE, decrease 1 st. every 6th row 5x, every 4th row 7x. After Row 148, bind off the remaining sts.

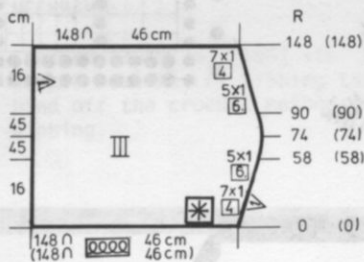

DK 415

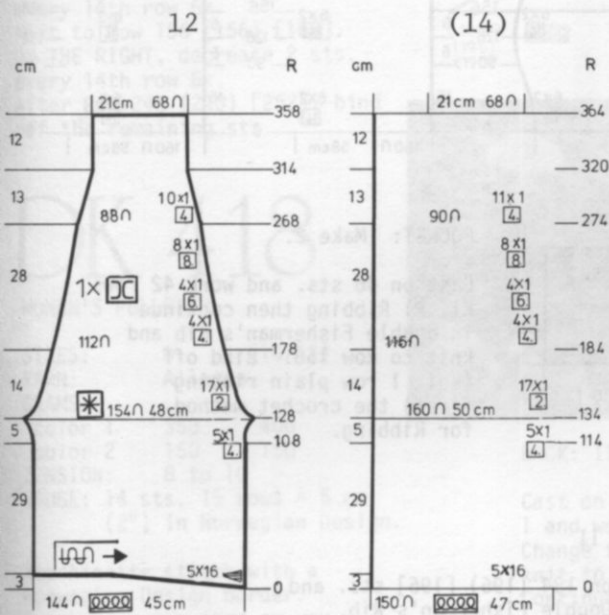

PANTS: Make 1, reverse 1.

Cast on 144 (150) sts. with color 1 and work Stockinette stitch.
 Work SHORT ROWS:
 Put all but 16 sts. on the RIGHT (left for 2nd section) into holding position, knit 2 rows (be sure to wrap the inside needles in holding position to prevent a hole).
 Bring back into working position 16 sts. 4x then bring the remaining stitches into work and continue in Stockinette stitch to Row 108 (114).
 ON EACH SIDE, increase 1 st. every 4th row 5x.
 After Row 128 (134), continue in the Norwegian Design.
 ON EACH SIDE, on every 2nd row, decrease 1 st. 17x.
 Knit to Row 178 (184).
 ON EACH SIDE, decrease 1 st. every 4th row 4x, every 6th row 4x, every 8th row 8x.
 Knit to Row 268 (274).
 ON EACH SIDE, decrease 1 st. every 4th row 10x (11x).
 Knit to Row 358 (364), then bind off the remaining sts.



DK 416

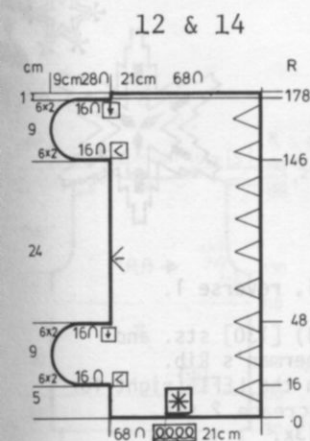

HAT:

With contrast waste yarn, cast on 68 sts.
 Knit 8 to 10 rows, then put Counter at 0 and continue in the Norwegian Design.
 After Row 16 *cast on 16 sts. on the LEFT side (use a separate yarn to cast on), then on every 2nd row, cast on 2 sts. 6x.
 Knit 8 rows, then bind off 2 sts. 6x.**
 Knit to Row 146.
 REPEAT the instructions from * to ** for the other flap.
 After Row 178, remove the sts. onto waste yarn. Weave the back seam together and remove the waste yarn.

HAT BANDS:

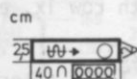

Cast on 40 sts. with color 4 and work 10 rows Stockinette stitch then bind off.

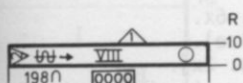

Cast on 198 sts with color 4 and work 10 rows Stockinette stitch then bind off.

MITTENS: Make 1, reverse 1.

Cast on 64 sts. with color 4 and work 40 rows K1, P1 Ribbing.
 Continue in the Norwegian Design.
 After Row 58, using waste yarn, knit 6 rows by hand over needles 35 to 43 counting from the RIGHT (left for 2nd mitten). Immediately cast on over these same needles with waste yarn. Continue over all the needles in the Norwegian Design to Row 108.
 Put half the sts. on the left (right) into holding position and *continue in Stockinette stitch with color 4. Bind off 1 st. beginning EVERY ROW till 3 sts. remain.
 Move the Cam Box to the left side, turn the Row Counter back to 108 and REPEAT from *.
THUMB: With wrong side facing you, pick up the 9 sts. held on lower section of thumb opening. Remove the waste yarn. With color 4, work Stockinette stitch.
 Knit 20 rows, then work SHORT ROWS. ON OPPOSITE SIDE OF CAM BOX, put into holding position, 1 st. 3x ON EACH SIDE.
 Bring back 1 needle OPPOSITE CAM BOX until all are in work.
 Knit 20 rows. Remove on waste yarn. Weave the open sts. of the thumb to the top opening on hand section. Fold mitten in half and sew sides of thumb then hand and top opening.

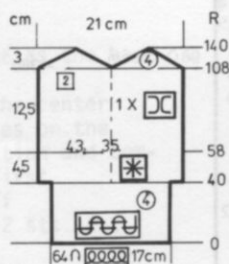

DK 417

WOMAN'S COAT

SIZES: 12 (14) [16]
 YARN: Allegro
 GRAMS: 1100 1150 1200
 TENSION: 8 to 10
 GAUGE: 14 sts. 30 rows = 5 cm (2")



Double Fisherman's (Brioche) Rib. KNITTING machine owners, put the Gate Cam Release Lever of both knitter and Ribber to the needle heels.

FINISHING: See General Instructions.

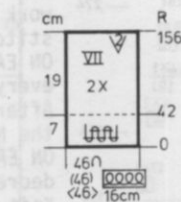
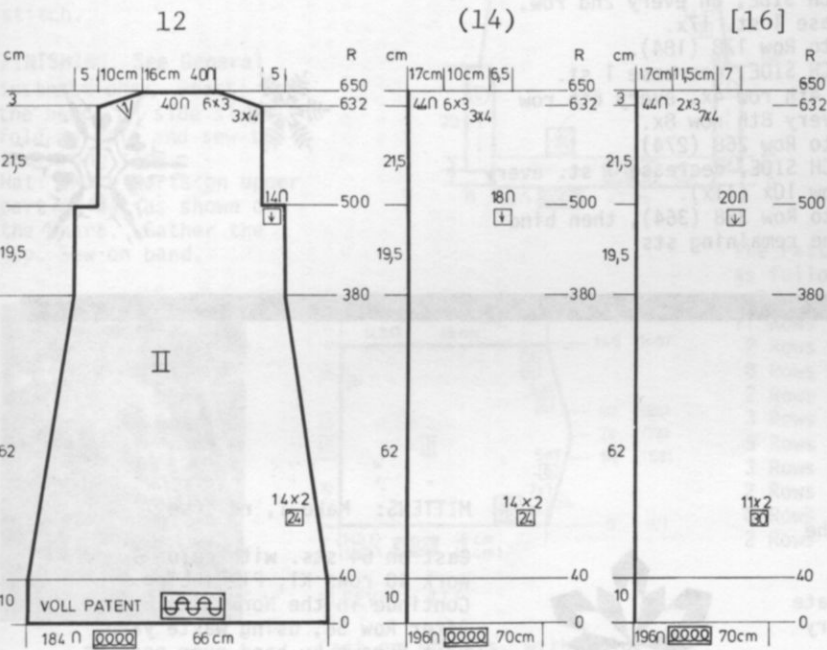
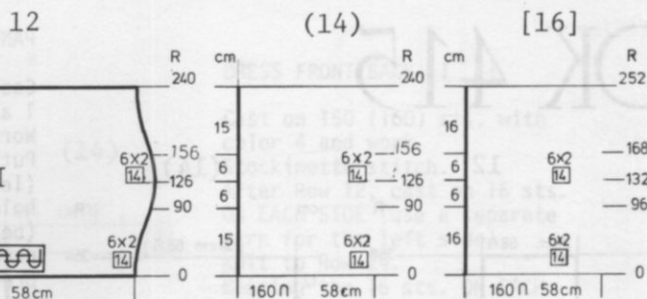

POCKET: Make 2.

Cast on 46 sts. and work 42 rows K1, P1 Ribbing then continue in double Fisherman's Rib and knit to Row 156. Bind off (knit 1 row plain ribbing first) the crochet method for Ribbing.

BACK: II

Cast on 184 (196) [196] sts. and work Double Fisherman's Rib. Knit to Row 40. ON EACH SIDE, decrease 2 sts. every 24th row 14x. (same as first size). [every 30th row 11x]. Knit to Row 500. SHAPE ARMHOLE: ON EACH SIDE, bind off 14 (18) [20] sts. Knit to Row 632. SHAPE SHOULDER: ON EACH SIDE, bind off 4 sts. 3x, 3 sts. 6x. (same as first size). [4 sts. 7x, 3 sts. 2x]. After Row 650, bind off the remaining sts.

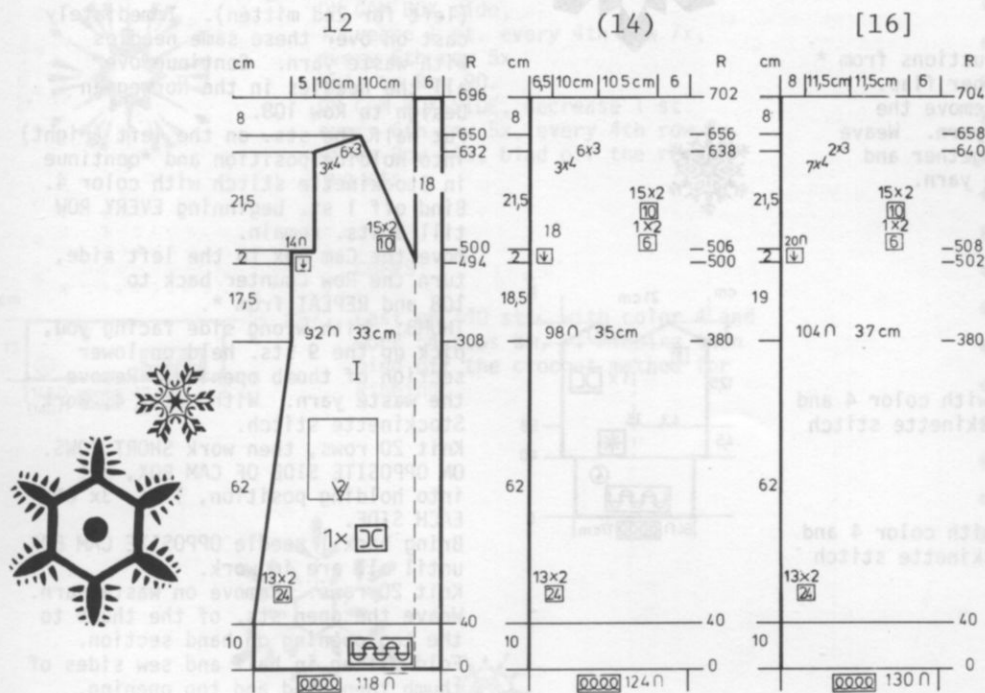

FRONT: I Make 1, reverse 1.

Cast on 118 (124) [130] sts. and work Double Fisherman's Rib. After Row 40, on the LEFT (right for 2nd section), decrease 2 sts. every 24th row 13x. Knit to Row 494 (500) [502]. Remove 18 sts. on the RIGHT (left) onto a stitch holder. After Row 499 (505) [507], bind off 14 (18) [20] sts. for armhole and ON NECK SIDE, bind off 2 sts. every 10th row 15x. (2 sts. every 6th row 1x, every 10th row 15x). [Same as 2nd size]. AND AT THE SAME TIME, after Row 631 (637) [639], SHAPE SHOULDER: Bind off 4 sts. 3x, 3 sts. 6x. (same as first size). [4 sts. 7x, 3 sts. 2x]. Hang the 18 facing sts. back onto the machine. Turn the Row Counter back to 494 (500) [502] and knit to Row 696 (702) [704]. Bind off.

SLEEVE: III

Cast on 160 sts. and work Double Fisherman's Rib. ON THE RIGHT, increase 2 sts. every 14th row 6x. Knit to Row 156 (156) [168]. ON THE RIGHT, decrease 2 sts. every 14th row 6x. After Row 240 (240) [252], bind off the remaining sts.

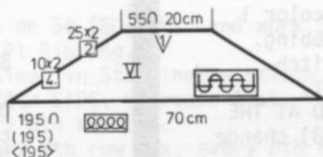

COLLAR: VI

Cast on 195 sts. and work Double Fisherman's Rib. ON EACH SIDE, bind off 2 sts. every 4th row 10x, every 2nd row 25x. Bind off the remaining sts.

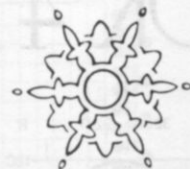

DK 418

WOMAN'S PULLOVER

SIZES: 8 (10/12)

YARN: Allegro

GRAMS: color 1 350 400

color 2 150 150

TENSION: 8 to 10

GAUGE: 14 sts. 15 rows = 5 cm (2") in Norwegian Design.

Stockinette stitch with a Norwegian Design border. Punch your own card or you can follow the Punch Card illustration. Bands are K1, P1 Ribbing as well as the Collar.

FINISHING: See General Instructions.



BACK: II

Cast on 124 (134) sts. with color 1 and work 30 rows K1, P1 Ribbing. Change to Stockinette stitch and knit to Row 56 (60). Continue with the Norwegian Design to Row 116 (120) using color 2 as the background color and 1 for the Design. Change to Stockinette stitch and color 1 and knit to Row 130 (134). SHAPE ARMHOLE: ON EACH SIDE, bind off 3 sts. 2x, 2 sts. 2x, 1 st. 4x. (4 sts. 1x, 3 sts. 1x, 2 sts. 2x, 1 st. 3x). Knit to Row 188 (194). SHAPE SHOULDER and watch for neck shaping. FOR SHOULDER, ON EACH SIDE, bind off 5 sts. 4x, 4 sts. 1x. (5 sts. 4x, 6 sts. 1x). FOR NECK: After Row 192 (198), bind off the center 36 sts. put the needles on the left into holding position and complete the right side first. *ON NECK SIDE, bind off 2 sts. 3x (3 sts. 3x). Move the Cam Box to the left side, turn the Row Counter back to 192 (198) and complete the left half. Follow the instructions from * and don't forget to complete the shoulder shaping.

FRONT: I

Work the front the same as the back to Row 170 (174). SHAPE NECK: Bind off the center 12 sts., put the needles on the left into holding position and complete the right side first. *ON NECK SIDE, bind off 4 sts. 1x, 3 sts. 2x, 2 sts. 2x, 1 st. 4x. (4 sts. 1x, 3 sts. 3x, 2 sts. 2x, 1 st. 4x). Knit to Row 188 (194). SHAPE SHOULDER same as the back. Move the Cam Box to the left side, turn the Row Counter back to 170 (174) and complete the left half. Follow the instructions from *

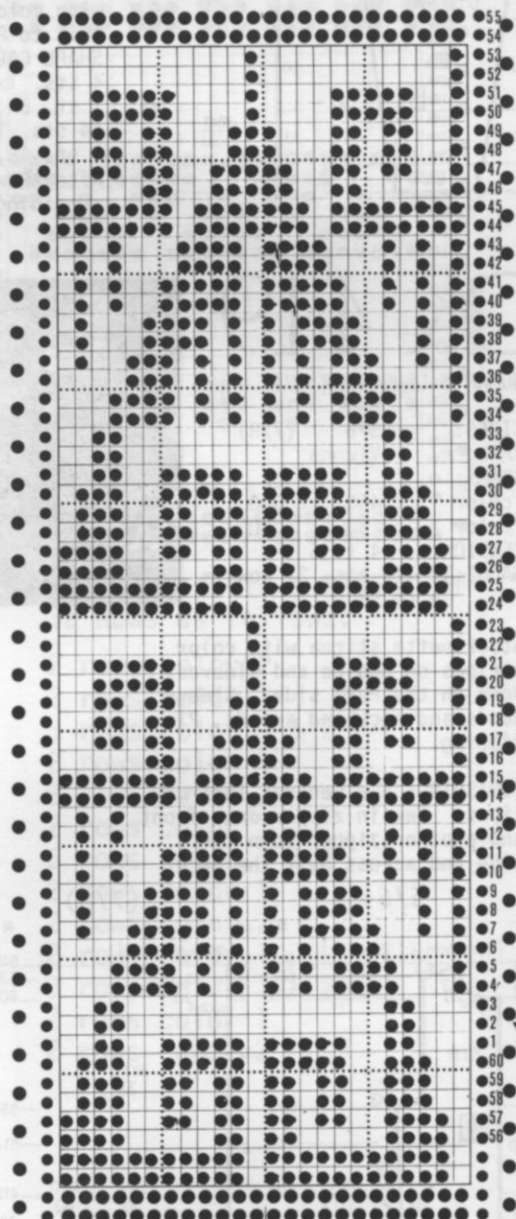

The Pattern is a total of 60 rows with Color 2 as the BACKGROUND color and color 1 for the Design.

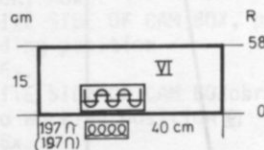

COLLAR: VI

Cast on 197 sts. with color 1 and work 58 rows K1, P1 Ribbing then bind off the crochet method for Ribbing.

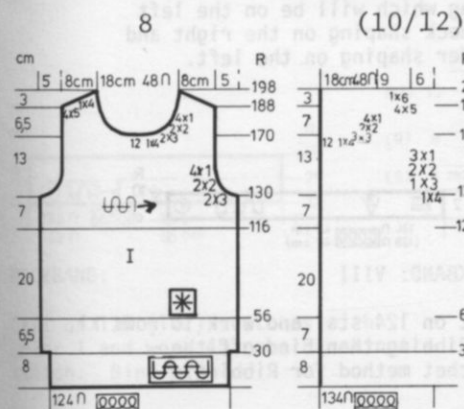
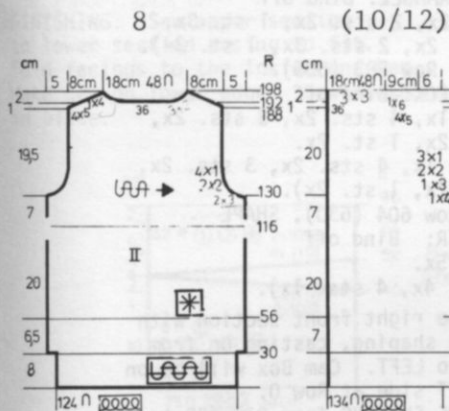

DK 418

SLEEVE: III

Cast on 58 (64) sts. with color 1 and work 20 rows K1, P1 Ribbing. Continue in Stockinette stitch. ON EACH SIDE, increase 1 st. every 6th row 17x (16x) AND AT THE SAME TIME, after Row 64 (68) change to the Norwegian Design. Knit to Row 124 (128). Continue in Stockinette stitch with color 1. Knit to Row 138 (142). SHAPE CAP: ON EACH SIDE, bind off 4 sts. 1x, 3 sts. 1x, 2 sts. 2x, 1 st. 3x, 2 sts. 12x. (4 sts. 1x, 3 sts. 1x, 2 sts. 2x, 1 st. 4x, 2 sts. 12x). After Row 180 (186) bind off the remaining sts.

BODICE BACK: II

ON THE EXTREME LEFT of machine, cast on 1 st. Work Stockinette st. ON EVERY 2nd Row, on the RIGHT, cast on 1 st. 7x more, then cast on 2 sts. 11x, then cast on 84 (94) sts. You now have 114 (124) sts. Knit to Row 92. ON EACH SIDE, increase 1 st. every 20th row 4x. After Row 144 (150) work the color stripes of 2 rows color 2, 4 rows color 1 until there are 5 stripes of color 2. Continue with color 1. After Row 172 (178) SHAPE ARMHOLE: ON EACH SIDE, bind off 3 sts. 1x, 2 sts. 2x, 1 st. 4x. (3 sts. 2x, 2 sts. 2x, 1 st. 2x). Knit to Row 244 (254). Bind off the center 32 (34) sts., put the needles on the left into holding position and complete the right side first. *SHAPE SHOULDER AND NECK AT THE SAME TIME. FOR SHOULDER, bind off 5 sts. 5x. (6 sts. 4x, 4 sts. 1x). FOR NECK, on all sizes, bind off 3 sts. 3x. Bring the needles on the left into working position, knit 1 row to the left side, turn the Row Counter back to 244 (254) and complete the left half. Follow the instructions from *.

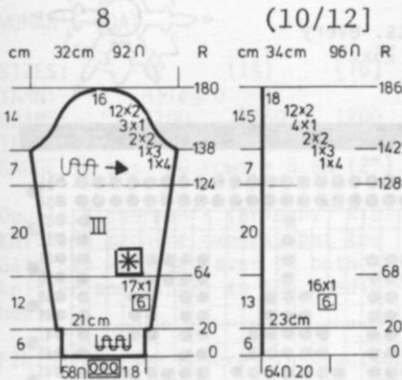

DK 419

WOMAN'S LONG JOHN SUIT

SIZES: 5/6 (7/8)
 YARN: Vienna
 GRAMS: color 1 450 500
 color 2 50 50
 TENSION: 4 to 6
 GAUGE: 15 1/2 sts. 22 rows = 5 cm (2).



Stockinette stitch with color stripes on bodice and sleeves. Worn on the Purl side. Sleeve bands and neckband are K1, P1 Ribbing.

FINISHING: See General Instructions. Sew in zipper down front and another zipper down the side and across half the back.

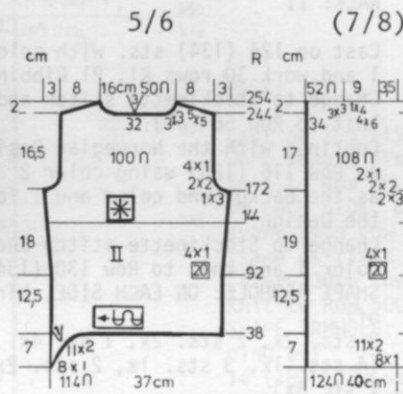
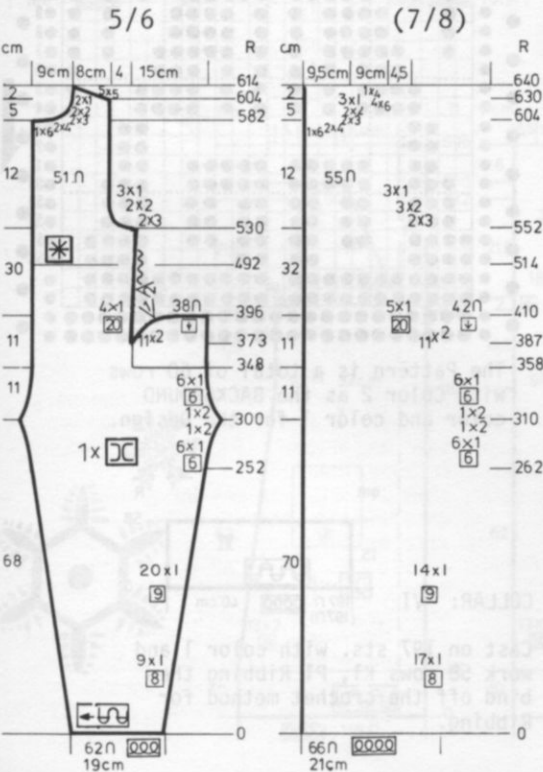

PANTS & FRONT BODICE: Make 1, reverse 1 but watch for special shaping to be worked on one side of pants only.

Cast on 62 (66) sts. and work Stockinette stitch. ON EACH SIDE, increase 1 st every 8th row 9x (17x), every 9th row 20x (14x). Knit to Row 252 (262). ON EACH SIDE, increase 1 st. every 6th row 6x, then cast on 2 sts. 1x. After Row 300, ON EACH SIDE, bind off 2 sts. 1x, then every 6th row decrease 1 st. 6x. After Row 348 (358), leave 60 (64) sts. on the RIGHT in working position and put the needles on the left into holding position. Knit to Row 373 (387). Bind off 2 sts. 11x, for all sizes, then after Row 396 (410), bind off the remaining 38 (42) sts. Bring the remaining sts. into working position, turn the Row Counter back to 348 (358). Attach yarn and knit to Row 396 (410). ON SIDE EDGE, increase 1 st. every 20th row 4x (5x). After Row 492 (514), work the color stripes of 2 rows color 2, 4 rows color 1 until there are 5 stripes of color 2. Continue with color 1. Knit to Row 530 (552)

SHAPE ARMHOLE: Bind off 3 sts. 2x, 2 sts. 2x, 1 st. 3x. (3 sts. 2x, 2 sts. 3x, 1 st. 3x). Knit to Row 583 (605). SHAPE NECK: Bind off 6 sts. 1x, 4 sts. 2x, 3 sts. 2x, 2 sts. 2x, 1 st. 2x. (6 sts. 1x, 4 sts. 2x, 3 sts. 2x, 2 sts. 2x, 1 st. 2x). After Row 604 (630), SHAPE SHOULDER: Bind off 5 sts. 5x. (6 sts. 4x, 4 sts. 1x). Work the right front section with reverse shaping, casting on from RIGHT to LEFT. Cam Box will be on the LEFT side at Row 0. OMIT THE SHAPING from Row 373 to 396. Knit straight up to the Armhole Shaping which will be on the left with neck shaping on the right and shoulder shaping on the left.

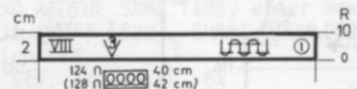

NECKBAND: VIII

Cast on 124 sts. and work 10 rows K1, P1 Ribbing then bind off the crochet method for Ribbing.

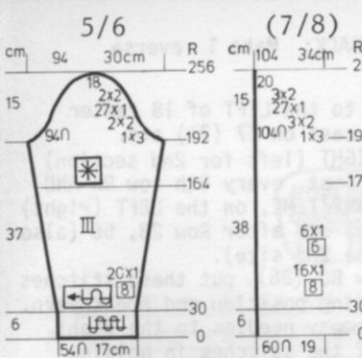

SLEEVES: III
 Cast on 54 (60) sts. and work 30 rows K1, P1 Ribbing.
 Continue in Stockinette stitch.
 ON EACH SIDE, increase 1 st. every 8th row 20x. (every 8th row 16x, every 6th row 6x).
 Knit to Row 164 (170). Work the color stripes the same as the back & front.
 After Row 192 (198) SHAPE CAP:
 ON EACH SIDE, bind off 3 sts. 1x, 2 sts. 2x, 1 st. 27x, 2 sts. 2x. (3 sts. 1x, 2 sts. 3x, 1 st. 27x, 2 sts. 3x).
 After Row 256 (264), bind off the remaining sts.

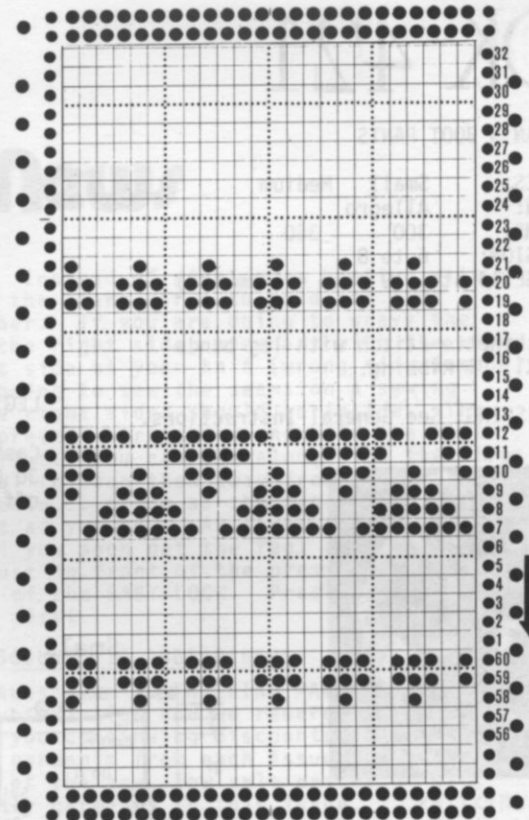

DK 420

WOMAN'S CAPE
 SIZES: Small Medium
 YARN: Allegro
 GRAMS: color 1 1000 1100
 color 2 250 250
 TENSION: 6 to 8
 GAUGE: 13 sts. 20 rows = 5 cm (2")



The Cape is knitted in 2 sections and worked sideways on the machine using Short Rows. A Norwegian Design is worked into the upper section. Punch your own Card.

FINISHING: Sew upper section to lower section easing to fit. Fold facings to the inside and hem. Make hem on lower edge. Sew neckband in place.

TOP SECTION:

Cast on 75 sts. with color 1.
 Knit 24 rows Stockinette stitch.
 10 rows Norwegian Design.
 6 rows Stockinette stitch color 1. (Row 40).
 *Work SHORT ROWS, color 1 ON OPPOSITE SIDE OF CAM BOX, put into holding position 10 sts. 2x, 11 sts. 4x. Bring back into working position 11 sts. 4x, 10 sts. 2x. Work the 32 rows in the Norwegian Design.
 REPEAT from * 7x (8x) putting the Row Counter to 0 each time and each Panel is 56 rows.
 THEN knit 6 rows Stockinette stitch with color 1
 10 rows Norwegian Design.
 24 rows Stockinette stitch with color 1. Bind off.

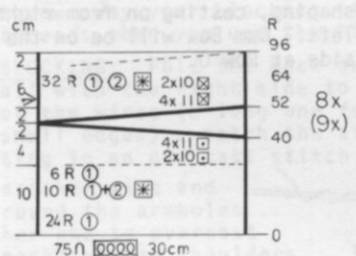

The Pattern is a REPEAT of 32 Rows as follows:

- 2 rows color 2
- 2 rows color 1
- 3 rows color 1 & 2
- 2 rows color 1
- 2 rows color 2
- 2 rows color 1
- 6 rows color 1 & 2
- 2 rows color 1
- 2 rows color 2
- 2 rows color 1
- 3 rows color 1 & 2
- 2 rows color 1
- 2 rows color 2

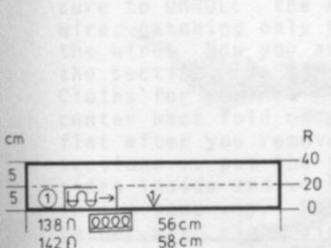

NECKBAND:
 Cast on 138 (142) stitches with color 1 and work 40 rows Stockinette stitch. Bind off.



LOWER SECTION:

Cast on 197 sts. with color 1 and work Stockinette stitch.
 Knit to Row 40.
 *Work SHORT ROWS. ON OPPOSITE SIDE OF CAM BOX, put into holding position 30 sts. 6x. ON OPPOSITE SIDE OF CAM BOX bring back into working position 30 sts. 6x. Knit to Row 104.
 REPEAT from *(but each time put Row Counter to 0) 8x (10x) more. Each panel is a total of 64 rows. Bind off.

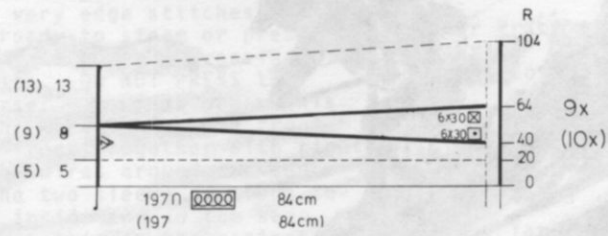

DK 421

WOMAN'S BOOT PANTS

SIZES: Small Medium
 YARN: Allegro
 GRAMS: 300 350
 TENSION: 6 to 8
 GAUGE: 14 sts. 19 rows = 5 cm (2")

Stockinette stitch with leg bands
 in K1, P1 Ribbing.

FINISHING: See General Instructions.

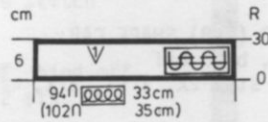

LEG BANDS: Make 2.

Cast on 94 (102) sts. and work
 30 Rows K1, P1 Ribbing then bind
 off the crochet method for Ribbing.

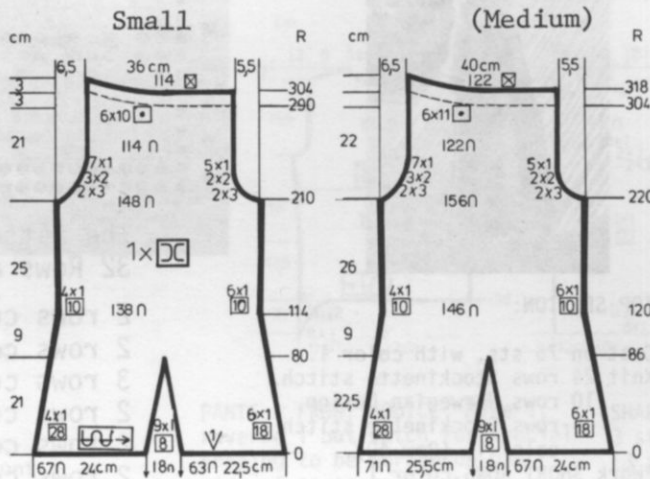

FRONT & BACK: Make 1 reverse
 1.

Directly to the LEFT of 18 center
 needles, cast on 67 (71) sts.
 ON THE RIGHT (left for 2nd section)
 increase 1 st. every 8th row 9x AND
 AT THE SAME TIME, on the LEFT (right)
 decrease 1 st. after Row 28, 56 (also
 84 for the 2nd size).

After Row 80 (86), put these stitches
 into holding position and break yarn.
 Leave 9 empty needles to the right
 (left) of the stitches in holding
 position, then cast on 63 (67)
 sts. on the right (left).

On the LEFT (right) increase 1 st.
 every 8th row 9x AND AT THE SAME
 TIME, on the RIGHT (left), decrease
 1 st. after Rows 18, 36, 54, 72.

After Row 80 (86), bring the needles
 in holding position back into work-
 ing position and continue over all
 the needles.

Continue to SHAPE EACH SIDE at
 the same time.

On the LEFT (right) decrease 1 st.
 after Rows 84, 112 and on the RIGHT,
 (left), decrease 1 st. after Rows 90,
 108. 138 (146) sts.

After Row 114 (120) on the RIGHT (left)
 increase 1 st. every 10th row 6x and
 AT THE SAME TIME on the LEFT (right)
 increase 1 st. every 10th row 4x.
 Knit to Row 210 (220).

PLEASE FOLLOW THE CHART in your size
 for the DIFFERENT shapings on each
 side, taking off 15 sts. for the front
 crotch shaping and 19 sts. for the
 back crotch shaping. 114 (122) sts.
 remain.

Knit to Row 291 (305) then work
 SHORT ROWS:

ON OPPOSITE SIDE OF CAM BOX, put
 into holding position
 10 (11) sts. 6x.

Bring all the needles back into working
 position and knit to Row 304 (318).

Bind off all sts.
 Work the second section with REVERSE
 shaping, casting on from right to
 left. Cam Box will be on the LEFT
 side at Row 0.





Knitking News

PRACTICAL KNITTING HINTS

PUNCH CARD ILLUSTRATIONS

You will note that in this issue of KNITKING MAGAZINE, we are providing PUNCH CARD ILLUSTRATIONS for some of the designs to be knitted into the garments.

If you have a KNITKING AM 3 machine, you can punch a blank JAC 40 Card. If you own a BROTHER 820 or a new KNITKING 830 machine, the Punch Card Illustrations are shown just as they should be punched. You can also punch the cards for a Studio machine, a Juki or any other machine that uses 24 stitch repeat punch cards. The color sequence, numbers of rows and color changes are printed along-side or below the card illustrations. You can if you like, mark your card accordingly or simply follow the printed instructions.

SEWING GARMENTS ON BABY LOCK OR SEWING MACHINE

More and more knitters are putting their garments together by sewing them on a sewing machine. If you own a BABY LOCK 605, you can sew sections together using the chain stitch only, without cutting, or you can shape flat sections by using the cut, sew, overlock method. If you own a BABY LOCK 405, you use the cut, overlock method as this machine has a closed overlock and does not have the chain stitch. It is possible to sew knitted sections together on a regular sewing machine but you must be sure the tensions are set so that there is no pulling or ruffling on the knitting. You do not get a seam as elastic as with the BABY LOCK.

PIANO WIRES

Indispensable... inexpensive... and fantastic to use... are the sets of Piano Wires (3 long, 3 short in package - the price is \$1.95, Calif residents add Sales Tax, plus 50¢ shipping). You can throw away your blocking pins and forget basting threads when you use the Piano Wires...

FOR BLOCKING: Fold the back section of your knit in half with the right side to the inside. Using one of the wires (a long one for long edges, short for small edges).. catch the side edges of the knitting in an overcast stitch (see illustration).

Use another wire and go around the armholes... another one to overcast the neckline and shoulders... Do not stretch the knitting, but keep it smooth and flat and be sure to UNROLL the edges as you baste with the wire, catching only the very edge stitches with the wire. Now you are ready to steam or press the section. Be sure to use our new Pressing Cloths for perfect results. DO NOT PRESS the center back fold of course. - you can press this flat after you remove the wires. For the front sections... put the two fronts together with right sides inside and work the wires around the edges in the same way. Put the two sleeve sections together with right sides inside and do the same thing. You will find that this is the easiest way to block and have perfect edges for sewing together whether you weave the seams by hand or sew them on a machine. When the pressed sections are cool and dry, you can remove the wires.

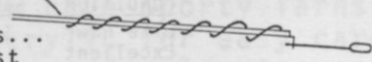

FOR SEWING: Instead of pinning or basting with a thread, use the Piano Wires to hold the side seams together. If you are going to weave the seams from the right side, overcast with the wire on the right side of your knit (wrong side inside) If you are going to sew the seams on a sewing machine, the right sides should be inside. The wires will prevent stretching and hold the knitted pieces flat. You can sew along-side the wires being careful to keep them away from the presser foot and needle... or do as the experts do, pull the wire out as you sew. At first it may seem awkward, but you soon get the feel and the wire slips out just in front of the presser foot or front plate of the BABY LOCK. Practice on a bit of knitting first.

BIG YARN DISCOUNTS TO SUBSCRIBERS

It pays to subscribe to KNITKING MAGAZINE. We need your subscription and we reward your support by offering you continuing discounts on the Kits to knit the garments from each issue... Just take a look at the low, low sale prices of Kits for the lovely garments in this issue... KNITKING Yarns are the finest that money can buy... It is possible to obtain yarns at lower prices but if you want your garments to look like those in KNITKING MAGAZINE and to retain their shape and appearance, you cannot afford to buy anything but the best.... KNITKING YARNS are the BEST...

Subscribers please note that these discount prices only apply until your next issue of KNITKING MAGAZINE is delivered to you.

KITS - For this issue of KNITKING MAGAZINE

HP 393 - Yarn: Euro Sport			
SIZES:	38	(40)	[42]
Regular Price	\$6.45	\$7.74	\$9.03
Sale Price	4.85	5.82	6.79
Shipping Costs	1.65	1.65	1.65
HP 394 - Yarn: Binia			
SIZES:	36	(38)	[40]
Regular Price	\$15.29	\$16.68	\$18.07
Sale Price	11.44	12.48	13.52
Shipping Costs	1.65	1.65	1.65
HP 395 - Yarn: Binia			
SIZES:	32	(36)	[38]
Regular Price	\$11.12	\$12.51	\$13.90
Sale Price	8.32	9.36	11.04
Shipping Costs	1.65	1.65	1.65
DK 396 - Yarn: Euro Sport			
SIZES:	8	(10)	[12]
Regular Price	\$23.63	\$25.02	\$26.41
Sale Price	17.68	18.72	19.76
Shipping Costs	1.65	1.65	1.65
DK 397 - Yarn: Euro Sport			
SIZES:	8/10	(12/14)	[16/18]
Regular Price	\$24.51	\$25.80	\$27.09
Sale Price	18.43	19.40	20.37
Shipping Costs	1.65	2.15	2.15
KK 398 - Yarn: Euro Sport			
SIZES:	5/6	(7/8)	[9/10]
Regular Price	\$14.19	\$14.19	\$15.48
Sale Price	10.67	10.67	11.64
Shipping Costs	1.65	1.65	1.65

DK 399 - Yarn: Euro Sport			
SIZES:	6/7	(8/10)	[12/14]
Regular Price	\$12.90	\$15.48	\$16.77
Sale Price	9.70	11.64	12.61
Shipping Costs	1.65	1.65	1.65
KK 400 - Yarn: Binia			
SIZES:	8	(10)	[12]
Regular Price	\$ 9.73	\$12.51	\$13.90
Sale Price	7.28	9.36	11.04
Shipping Costs	1.65	1.65	1.65
HP 402 - Yarn: Fortissima			
SIZES:	Small	(Medium)	[Large]
Regular Price	\$12.72	\$15.90	\$19.08
Sale Price	9.52	11.90	14.28
Shipping Costs	1.00	1.00	1.00
KK 403 - Yarn: Allegro			
SIZES:	7/8	(9/10)	[11/12]
Regular Price	\$19.08	\$22.26	\$25.44
Sale Price	14.28	16.66	19.04
Shipping Costs	1.65	1.65	1.65
DK 404 - Yarn: Allegro			
SIZES:	Small	(Medium)	[Large]
Regular Price	\$11.13	\$12.72	\$12.72
Sale Price	8.33	9.52	9.52
Shipping Costs	1.00	1.00	1.00
DK 405 - Yarn: Crocus Crepe			
SIZES:	8/10	(12/14)	[16/18]
Regular Price	\$29.26	\$33.44	\$37.62
Sale Price	21.98	25.12	28.26
Shipping Costs	1.65	1.65	1.65
HP 406 - Yarn: Crocus Crepe			
SIZES:	36	(38)	[40/42]
Regular Price	\$35.53	\$39.71	\$43.89
Sale Price	26.69	29.83	32.97
Shipping Costs	1.65	1.65	2.15
DK 407 - Yarn: Beatrice Silver			
SIZES:	8/10	(12/14)	[16/18]
Regular Price	\$16.14	\$18.83	\$21.52
Sale Price	12.12	14.14	16.16
Shipping Costs	1.00	1.00	1.00
DK 408 - Yarn: Beatrice Silver			
SIZES:	8/10	(12/14)	[16/18]
Regular Price	\$21.52	\$24.21	\$26.90
Sale Price	16.16	18.18	20.20
Shipping Costs	1.65	1.65	1.65

DK 409 - Yarn: Beatrice Silver			
SIZES:	8/10	(12/14)	[16/18]
Regular Price	\$10.76	\$10.76	\$13.45
Sale Price	8.08	8.08	10.10
Shipping Costs	1.00	1.00	1.00
DK 410 - Yarn: Micaela & Capriccio			
SIZES:	5/6	(7/8)	[10/12]
Regular Price	\$34.16	\$39.40	\$44.64
Sale Price	25.61	29.54	33.47
Shipping Costs	1.65	1.65	1.65
DK 411 - Yarn: Capriccio			
SIZES:	5/6	(7/8)	[10/12]
Regular Price	\$13.00	\$16.25	\$16.25
Sale Price	9.76	12.20	12.20
Shipping Costs	1.00	1.00	1.00
DK 414/415/416 - Yarn: Fortissima 4 piece outfit.			
SIZES:	12	(14)	
Regular Price	\$50.88	\$57.24	
Sale Price	38.08	42.84	
Shipping Costs	2.65	2.65	
DK 417 - Yarn: Allegro			
SIZES:	12	(14)	[16]
Regular Price	\$34.98	\$36.57	\$38.16
Sale Price	26.18	27.37	28.56
Shipping Costs	2.15	2.15	2.15
DK 418 - Yarn: Allegro			
SIZES:	8	(10/12)	
Regular Price	\$15.90	\$17.49	
Sale Price	11.90	13.09	
Shipping Costs	1.65	1.65	
DK 419 - Yarn: Vienna			
SIZES:	5/6	(7/8)	
Regular Price	\$17.90	\$19.69	
Sale Price	13.40	14.74	
Shipping Costs	1.65	1.65	
DK 420 - Yarn: Allegro			
SIZES:	Small	(Medium)	
Regular Price	\$31.80	\$33.39	
Sale Price	23.80	24.99	
Shipping Costs	1.65	1.65	
DK 421 - Yarn: Allegro			
SIZES:	Small	(Medium)	
Regular Price	\$ 9.54	\$11.13	
Sale Price	7.14	8.33	
Shipping Costs	1.00	1.00	

SALE OF NEW, DEMONSTRATOR AND TRADE-IN MACHINES...

Our warehouses are again overloaded with traded knitting machines plus an assortment of new and demonstrator machines that we have to move in order to make room for the quantities of merchandise we are bringing in for the WARDROBE PLAN... If you want an outstanding buy in any brand of machine... now is the time to order... Some of the new machines are in short supply so if we cannot fill your order, your check will be returned... BROTHER owners, be sure to note that we have some new RIBBING ATTACHMENTS at the silly price of \$39.50 each.

SINGLE BED		CONDITION	SALE PRICE
BROTHER	820 Demonstrators	Like New	\$299.00
	587 (Same as 588)	Excellent	99.50
	551 & 580 Ribbing Attachments - Suitable for 550, 551, 585, 588 machines. (Be sure to tell us your Model Number).	New	39.50
KNITLEADERS - Demonstrators, 111, 113 & 115		Like New	49.50
GENIE	1500	Excellent	49.50
	1800	Excellent	79.50
JUKI	2400	New & like New	275.00
	2400 With New Ribbing Attachment	New	375.00
	1300	Like New	99.50
KNITCOPY		New	49.50
SPEED-O-KNIT		Excellent	50.00
STUDIO	324	New	299.00
	313 Traded	Very Good	99.50
DOUBLE BED		Very Good	\$150.00
DUOMATIC		Very Good	50.00
SWIFTOMATIC		Very Good	50.00
ORION - 360 needles		Very Good	50.00
TURMIX		Very Good	50.00
SWISS MAGIC		Excellent	50.00
REGINA - 360 needles		Very Good	50.00
BABY LOCK	205 - Cuts & Overlocks with two threads - New, being discontinued from our range - List		\$329.00 175.00
	405 3 thread Overlock & Cut. Ideal for knit materials. List \$359.00 Demonstrators	Excellent	199.00

new

knitking

Yarn catalogue



Our new range of yarns is absolutely fantastic... A fact you will realize immediately you start to use it... We have included yarns for all seasons... all garments... all tastes and all pockets... We have superb Fine Wool Crepe Yarns for garments that demand perfect finish and a look of quality... We have gorgeous Metallic mixtures for that glamorous Evening Outfit you have been promising yourself... We have Sporty Yarns for Sporty Garments... We have hard wearing Acrylic for easy care and hard wear... We have lovely blended Yarns to add color to your life... and we have, for the first time in our Catalogue, four new exclusive Cone Yarns.

Twenty five years of catering to the needs of machine knitters have gone into the preparation of the all new KNITTING YARN CATALOGUE and it is our best ever... Actual samples of all yarns and all colors are included.

Order your copy today... You deduct its price of \$2.00 (California residents add Sales Tax) from your first order of \$20.00 or more.

ORDER DIRECT FROM:

KNITTING: 1128 Crenshaw Blvd., Los Angeles, Calif. 90019

Punch your own Cards

FOR KNITTING 830 - BROTHER 820 - or STUDIO and JUKI Machines

With this inexpensive Kit...

The Punching Accessory is \$5.70

Set of 10 Blank Cards is 4.75

Total \$10.45

(California residents add Sales Tax)

Shipping & Handling Costs 1.50

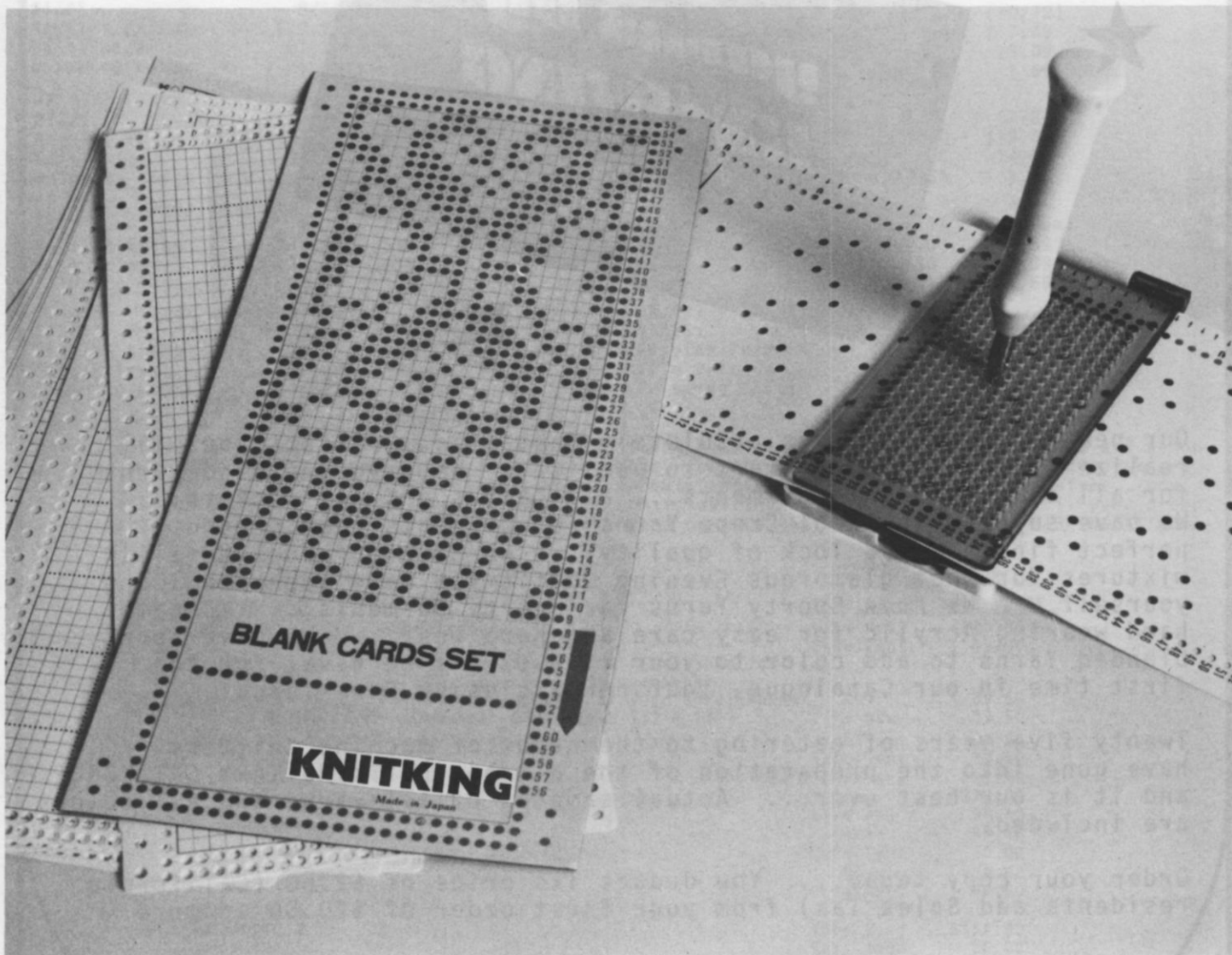

ORDER from your Dealer or DIRECT FROM:
 KNITTING - 1128 Crenshaw Blvd., Los Angeles, Calif. 90019

DK 397



HP 394

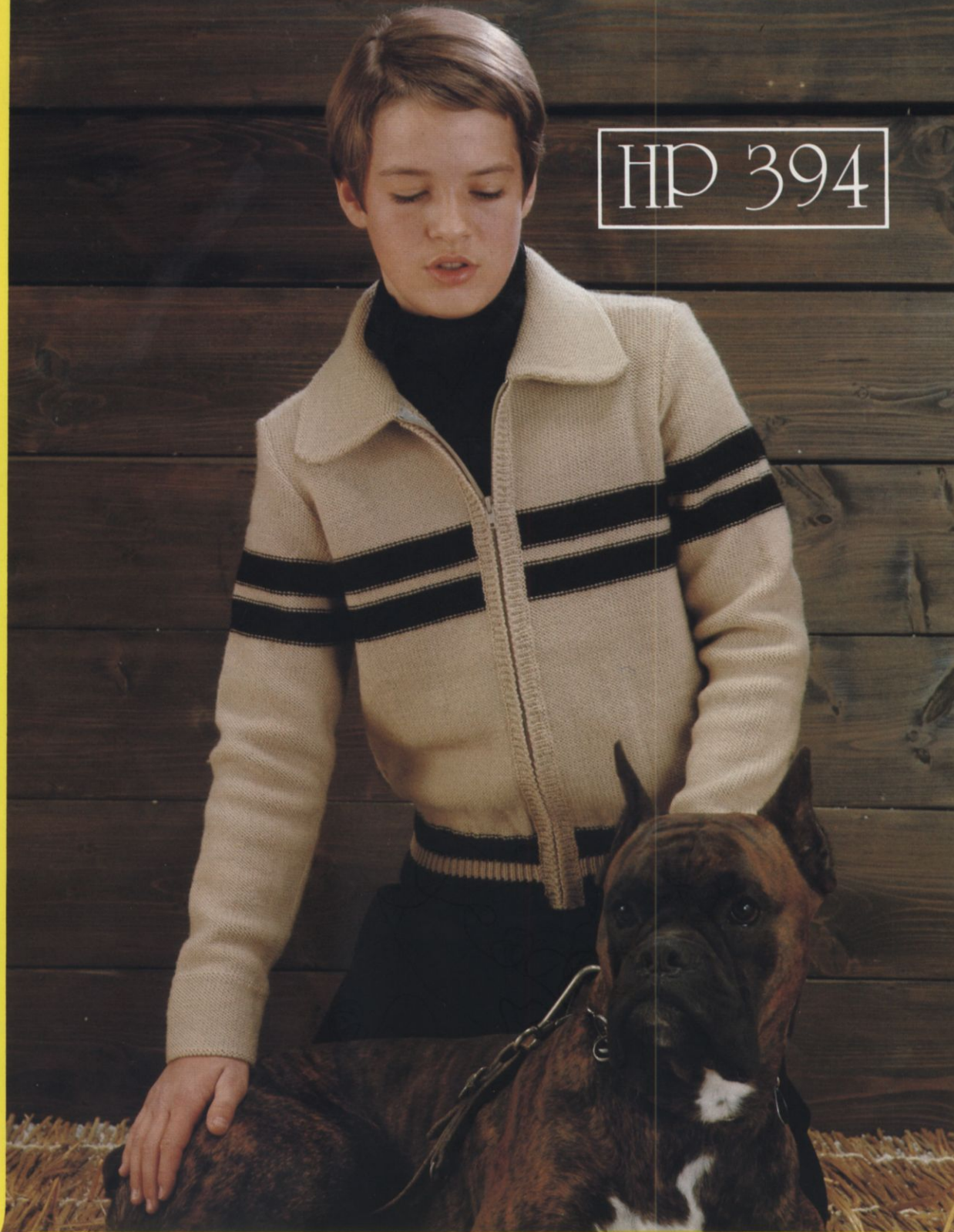

HP 393



HP 395



DK 419

HP 402

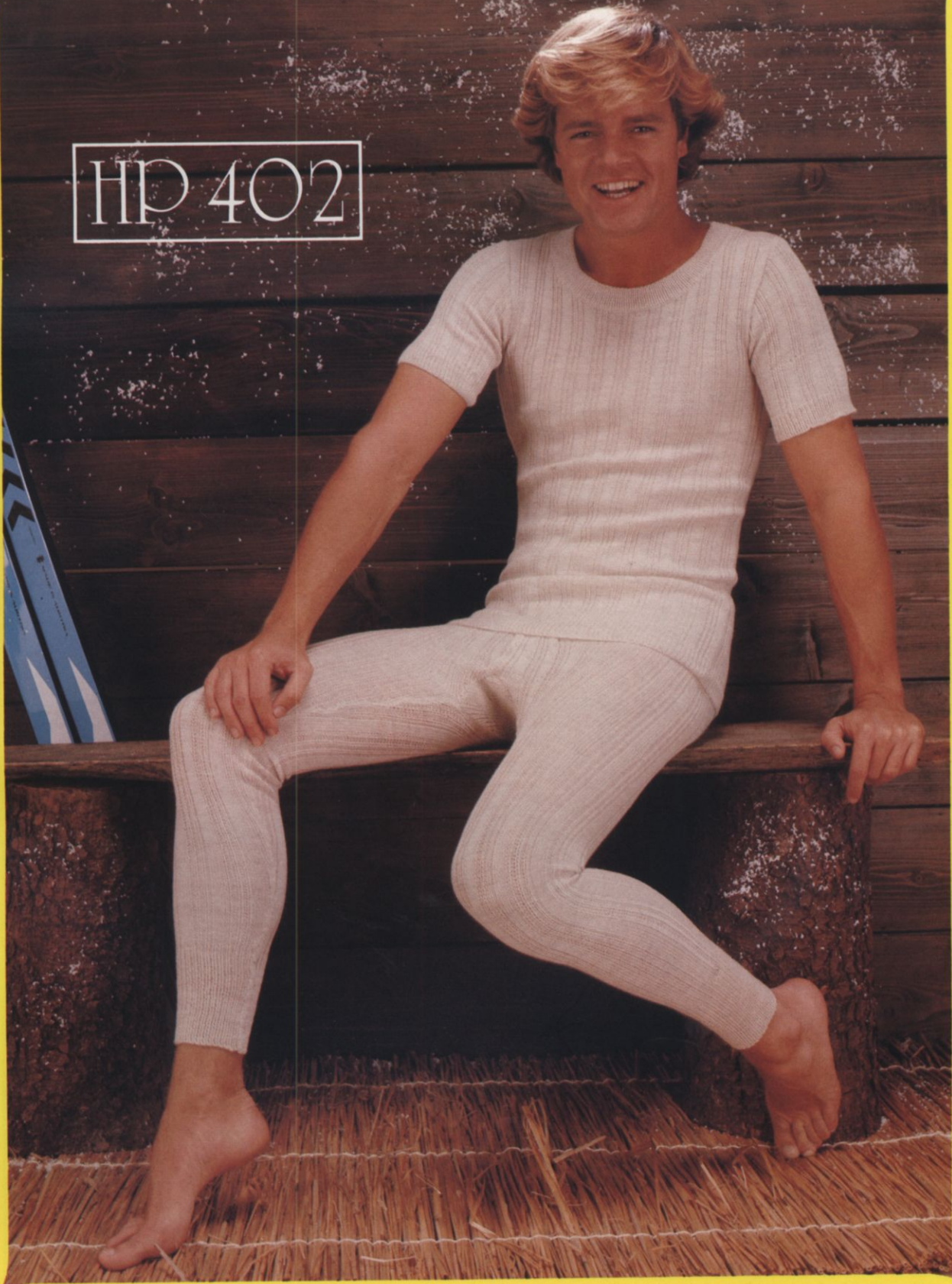

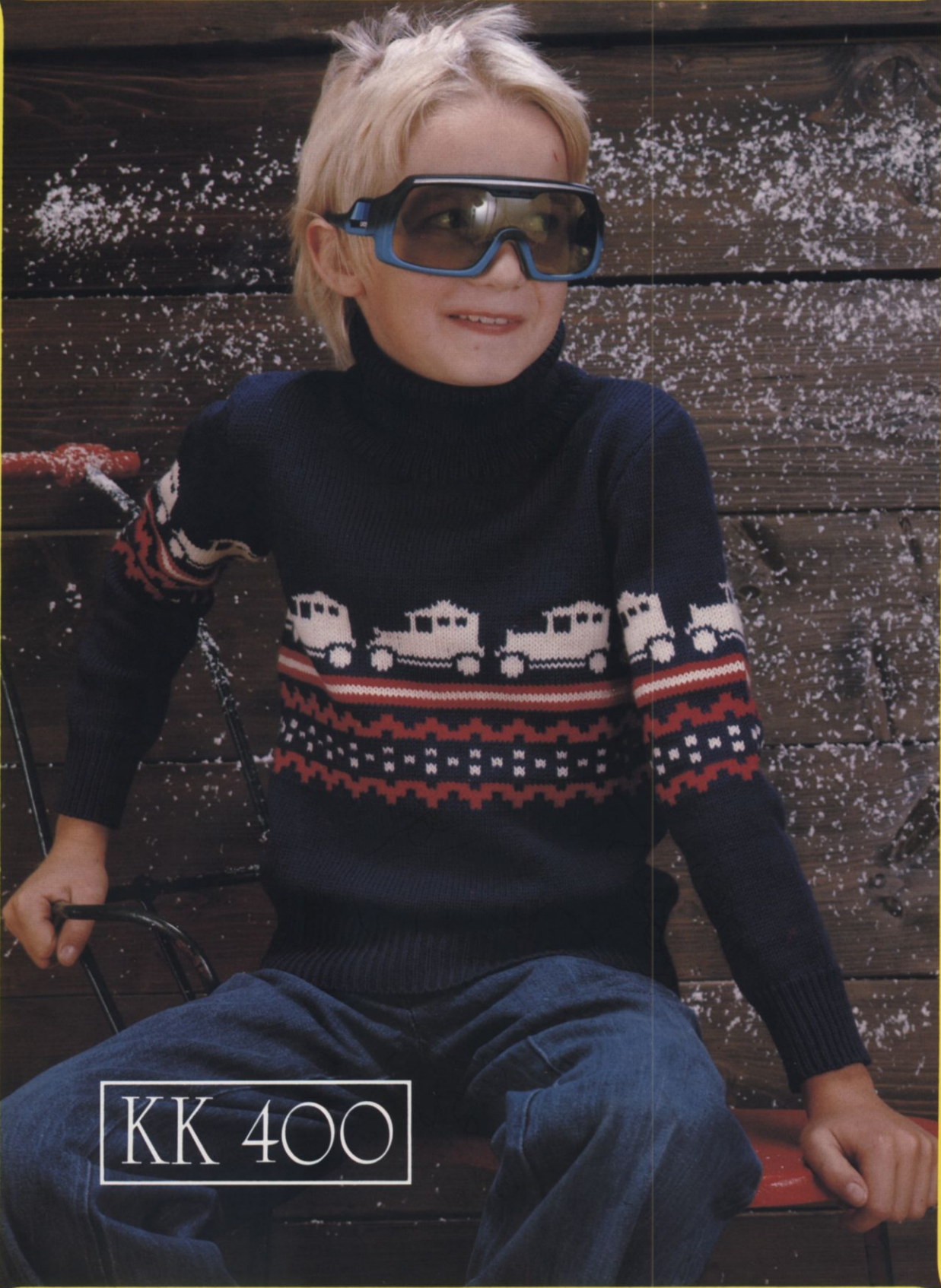

KK 400



KK 403

KK 398



SOCKS for EVERYBODY

MATERIAL: KNITTING Fortissima (amounts as shown at right for each size). The amount of yarn specified is for slack length and you should order extra yarn for longer socks. The amount of yarn specified for Baby socks will make at least two pair. **TENSION:** 4 to 6. **GAUGE:** 18 sts., 24 rows to 2".

FINISHING: Weave the open heel sts. to open leg sts. Remove waste yarn. Weave back of leg seam and sides of instep. You may make these socks shorter or longer by knitting more or less rows for leg length. Increase the number of sts. for larger leg by casting on any number of sts. divisible by 4 plus 1 st. If knitting them very long, be sure to cast on sufficient sts. and space decreases along the leg edges for proper shaping so that you end up with a number of stitches divisible by 4 at the beginning of the instep. If you wish to seam the sock along the instep as you knit the sole, pick up edge stitches on each side of instep on every other row as you knit (see Practical Knitting Hints Book, page 24). You may also use a stripe pattern, cable design or a Norwegian pattern for the leg and instep sections.



SIZE	INFANT		CHILDREN		WOMEN			MEN		
	3-4	5-6	7-8	9-10	8	9	10	Sm.	Med.	Large
MATERIAL: Balls (1½ oz.)	1	1	1	2	2	2	2	2	2	2
CUFF: Cast on sts.	41	45	49	53	57	57	61	65	69	73
Rib K1, P1 rows	12	14	18	24	24	24	30	18 for slack 36 for regulation		
Transfer rib sts. to main machine and decrease 1 st. on one side only.										
LEG: Knit rows	20	24	48	50	72	72	72	72 for slack 120 for regulation		
DIVIDE STS: On EACH SIDE remove onto a stitch holder.										
sts.	10	11	12	13	14	14	15	16	17	18
INSTEP: On remaining center sts. knit even rows	20	22	24	26	28	28	30	32	34	36
rows	18	22	30	42	72	78	84	84	96	108
TURN TOE: Short Rows. Put 1 needle opposite Cam Box into holding position beginning each row until sts. remain in work.										
sts.	4	4	6	6	6	6	6	8	10	10
Put back 1 needle opposite Cam Box beginning each row until all sts. are in work.										
SOLE: Knit even rows	18	22	30	42	72	78	84	84	96	108
TURN HEEL: Short rows. Put 1 needle opposite Cam Box into working position beginning each row until sts. remain in work.										
sts.	4	4	6	6	6	6	6	8	10	10
Put back 1 needle opposite Cam Box beginning each row until all sts. are in work.										
Knit several rows with contrast waste yarn and remove work from machine.										

