

knitking

magazine





dk 760

X1/2-79



dk 761

dk 747



dk 746



dk 749



CR 743



OK 754



dk 745



dk 742



VOLUME 15, NO 2

knitking

magazine

editorial

TABLE OF CONTENTS	PAGE NO.
DK 742 Woman's Tank Top & Jacket	14
DK 743 Woman's Striped Pullover	15
DK 744 Woman's Sleeveless & Strapless Top	15
DK 745 Woman's Jacket & Pullover	17
DK 746 Woman's Pullover	18
DK 747 Woman's Skirt & Vest	20
DK 748 Woman's Dress	21
DK 749 Woman's Pullover	23
DK 750 Woman's Dress	23
DK 751 Woman's Vest & Skirt	25
DK 752 Woman's Dress & Jacket	26
DK 753 Woman's Jacket	28
DK 754 Woman's 2-piece Dress	29
HP 755 Man's Cardigan	30
KK 756 Child's Jacket & Socks	32
KK 757 Child's Pullover	33
KK 758 Child's Vest	34
KK 759 Child's Pullover	35
DK 760 Woman's Blouse	36
DK 761 Woman's Pullover	37
HP 762 Man's Sleeveless Pullover	38
HP 763 Man's Pullover	39
HP 764 Man's Jacket	40

Judging by letters and telephone calls coming in every day.. we will have a big crowd at the KNITKING SEMINAR and OPEN HOUSE... starting on October the 8th and running through the 13th... We will, as usual, have a team of experts on hand for the Classes and Lectures... We will also have a display of beautiful Garments and Accessories made on our various machines... In addition to garments made by our own staff, we are promised some designs by Carlos Arias and by Jo Ann Ducci...

Dorothy Akiyama, who worked for KNITKING for many years, has gone into partnership with Mitzi Tani... they are selling KNITKING products and doing contract knitting.... Dorothy is just back from a trip to Japan where she visited the machine Knitting Schools of BROTHER and SILVER to study their teaching methods... She also has talked with their Designers and will be at our SEMINAR to pass on her newly gained knowledge... Carlos Arias will be a guest lecturer as will Tami Nobuyuki... If you are planning to be at the SEMINAR and would like anything particular to be demonstrated or discussed, please drop us a line. We will try to include it in the program.

All yarns and other merchandise will be on sale at BIG SEMINAR DISCOUNTS and we expect to be demonstrating some new products including a Loom onto which you fit your own punch card machine. Your machine selects, through punch cards, the Weaving Pattern Designs as you feed the shuttles back and forth... The whole thing is efficient, very ingenious and quite fantastic. We look forward to meeting old and new friends at the SEMINAR.

The next issue of KNITKING MAGAZINE is well on its way and it includes a fine assortment of garments for the cooler weather plus some special Christmas Knick-Knacks... We are catching up and will, in fact, mail out six issues during 1979.





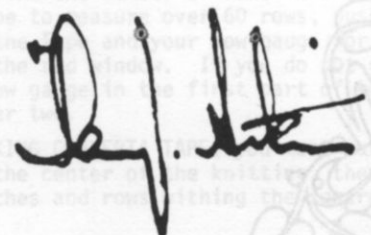









It is important that you notify us of any change of address ... as the Post Office will NOT forward Third Class Mail to you... they will either return your Magazine to us at the First Class postage rate or they will destroy it and just return the empty envelope...



Publisher: KNITKING CORPORATION, 1128 Crenshaw Blvd., Los Angeles, Calif. 90019. Telephone: (213) 938-2079. Published bi-monthly. Subscriptions: USA — \$15.00 annually, single copies \$4.00; Canada — \$18.00; other parts of the world — \$20.00. The entire contents of KNITKING MAGAZINE are copyright and must not be reproduced in any shape or form without the express permission, in writing of the publisher. ©COPYRIGHT 1979 by KNITKING CORPORATION.







Pattern Symbols

Knitting – Chart Symbols

- () Size Symbols (2nd Size)
- < > 3rd Size
- ① Color Number
-  Cast on
-  Stitch
- R Row
- H Hem
-  Bind off
-  Stockinette stitch – worn on the Knit side.
-  Stockinette stitch – worn on the Purl side.
-  Knit 1, Purl 1 Ribbing
-  Ribbing Pattern – worn on the Knit side.
-  Ribbing Pattern – worn on the Purl side.
-  Closed Dart
-  Open Dart
-  Put on a stitch holder
-  Reverse 1 section
-  On every other needle
-  Number of Rows between Shapings. Make increase (or decrease) FIRST, then knit 4 rows. For example: 3 x 1  means decrease (or increase) 1 st., knit 4 rows; decrease 1 st., knit 4 rows; decrease 1 st., knit 4 rows; decrease 1 st., knit 4 rows. All decreasing (or increasing) without row numbers as shown must be shaped on every 2nd row.





-  Increase
-  Increase 2 sts. With a transfer tool, move the sts. over the left (or right) leaving 2 empty needles at the point of increase. At the increase point, move 1 st. to the left, (or right) so that there is an empty needles on each side of a stitch. On each side of the center stitch, pick up a stitch from the row below and hang it onto the empty needle.

-  3 stitches on 1 needle. The 1st and 3rd stitch in a group of 3 has been hung on the 2nd or center needle.
-  Short Row increase or decrease; for instance on a flared skirt knitted sideways.









-  Pattern Stitch.
-  Pattern Stitch – worn on the Knit side.
-  Pattern Stitch – worn on the Purl side.

-  Repeat
- I = Front
- II = Back
- III = Sleeve
- IV = Skirt Front
- V = Skirt Back
- VI = Collar
- VII = Pocket
- VIII = Band
- IX = Belt
- X = Cuff
- XI = Pants Front
- XII = Pants Back.

Finishing – Chart Symbols

-  Match numbers on section for assembling.
-  Ease
-  Fold Line
-  Turn to the wrong side and hem.

Stitch Symbols

-  Needles in holding position
-  Needles back into working position.
-  Empty needle (leave in working position)
-  Needle not used (in the out of work position).
-  Two stitches on 1 needle, either transferred from the right side or the left side, then put into holding position.
-  Needle holding 2 stitches. Stitch has been transferred from the RIGHT.
-  Needle holding 2 stitches. Stitch has been transferred from the LEFT.
-  Center of garment section



General Instructions

HOW TO READ THE CHARTS AND INSTRUCTIONS

There are 3 sizes given for each Pattern in KNITKING MAGAZINE. Above each Chart for the different sizes, you will see that the first and smaller sizes might be shown as 8/10, the second size as (12/14) and the third as [16/18]. Check the measurements at the bustline and hips on the Charts to be certain that you will knit the correct size, remembering these are ACTUAL measurements of the completed section and that there must be a bigger allowance at the bustline and hipline for a Jacket or a Coat than there would be for a fitted dress or a fitted blouse or pullover. The question in your mind should be "How do I want this garment to fit...?"

When you have chosen the size you need, you can follow the Charts as shown. You will notice that where the shapings are the same FOR ALL SIZES, only 1 set of shapings will be shown on the first Chart and if you are knitting the 2nd or 3rd size, you simply follow the shapings as given for the first size. If the shapings are different, this will be shown on the Charts and you should follow them as given.

On the Charts, increases and decreases will be shown as follows

5x1

6 The number in the box means number of ROWS between the shapings, while the 5x1 above the box means - 1 st. 5x... so you will increase or decrease 1 st. every 6th row 5x.

ARMHOLE SHAPINGS - NECK SHAPINGS - SHOULDER SHAPINGS - are made on every 2nd row UNLESS there is a number in a box along side or below the shapings. The rule is... where there is no box with a number, the shaping is made on every 2nd row.

THE PRINTED INSTRUCTIONS

You can follow the printed instructions or use them in combination with the Charts. Where there is any question in the printed instructions, you have the Charts to show you how the section will look.

The 3 sizes, with the different amounts of cast on stitches and the different shapings will look like this...

Cast on 124 (136) [148] sts. You will

Cast on 124 sts. for the first size.

Cast on 136 sts. for the 2nd size.

Cast on 148 sts. for the 3rd size.

The important thing to remember is that you MUST READ AHEAD so that you KNOW what to do for the size you are knitting. Sometimes where the number of stitches are the same but the number of times different, you will find shapings like this... 3 sts. 1x (2x) [3x], 2 sts. 1x (2x) [3x], 1 st. 3x (4x) [5x]. As you see, you MUST read ahead in order to follow the instructions as given for YOUR SIZE. The rows will be different for the different sizes in some cases... Shoulder and Neck shapings usually are worked at the SAME TIME for the back section - so watch for the words AT THE SAME TIME.

HOLDING STITCHES ON THE LEFT SIDE WHILE SHAPING THE RIGHT SIDE

When knitting a section of garment in stockinette stitch, it is easy to hold the stitches on the left side while knitting the right half, but when knitting a Pattern Stitch such as a Norwegian Design, a Holding Position Design, Weaving, etc., you should use the following method. For the NECK SHAPING, we tell you to bind off the center sts., put the needles on the left into holding position and complete the right half first... so with a strand of contrast yarn, knit ALL of the left side stitches manually by hand, pulling each stitch back against the needle bed to the OUT OF WORK position. When the right side is completed, carefully pull the stitches held on contrast, forward into working position and as you do so, undo the contrast yarn, line up the needles (KNITKING AM 3 machine owners, put the stitches under the sinkers) and complete the left half.

If you own a Japanese machine, you may find that when knitting the right half with the left side held in this way, the sinker plate will mark the left side while you are knitting the right half. To prevent this marking, you can tape a piece of paper over the knitting, underneath the sinkers, or if you own a Reversing Bar, you can hang this onto the Sinkers while you are knitting the right half. When hanging the Reversing Bar, be sure the eyes of the bar go BETWEEN the Sinker Posts on the upper part of the bar so that the tips of the bar only - show above the needle bed.

FULL FASHION DECREASING OR INCREASING

For Stockinette stitch, always use the Full Fashion method for increasing or decreasing.

TO DECREASE: Hang the 3rd stitch onto the 2nd stitch then move the stitches in to fill the empty needle.

TO INCREASE: Move the 2 end stitches 1 needle outward, then pick up the 3rd stitch from the row below and hang it onto the empty needle.

FINISHING: Block all sections. For PULLOVERS, JACKETS, and DRESSES: Join front to back at sides and shoulders. Sew sleeves together and set in. Hem lower edge and sleeve edges if needed. For a double neckband or armhole band, sew 1 edge to the inside and 1 to the outside of neck or armhole. For a single ribbed band, sew 1 edge to the outside of neck or armhole edge. For a cardigan or jacket with buttonholes, finish buttonholes and sew on buttons.

PANTS: Join front to back at sides. Sew inside leg seams, then join center front and back. Make hem at waistline and insert elastic. Hem lower edge of pants legs.

THE SAMPLE SWATCH

Before you begin to knit any garment, you will need to knit a sample piece using the yarn you have chosen for your garment, so that you can check the stitch and row gauge which must measure the correct number of stitches and rows in 5 cm (2 inches).

For each Pattern in KNITKING MAGAZINE, we give you 3 tension numbers to work from and if you use the specified yarn for the garment, you should be able to get the correct stitch and row gauge using one of these numbers. Here is a very easy way to make your sample swatch and count the stitches and rows without actually counting, by using our KNITKING Converta Tape.

Supposing the Tension Numbers for the Stitch and Row Gauge are given as 5 to 7. Set the Tension Dial to the first number which is 5. With contrast waste yarn, and using the quick cast on method, cast on 60 stitches and knit 10 rows. Change to garment yarn and turn the Row Counter to 0. Knit 30 rows. Counting from each end, knit the 10th stitch on each side by hand with a small piece of contrast yarn. Leave the needles in working position and knit 30 rows (Row 60), then knit 4 rows with contrast waste yarn. Turn the Row Counter to 0 and the Tension Dial to 6 and with garment yarn, knit 30 rows. Mark the 10th stitch on each side as you did before, knit 30 rows, then 4 rows with contrast waste yarn. Turn the Row Counter to 0 and with Tension 7, repeat the above once more, ending with 10 rows of contrast waste yarn. Remove the work from the machine by passing the Slide across the needles without yarn (sometimes called 'dropping'). Pull and stretch the sample piece both lengthwise and diagonally from corner to corner, then lengthwise again. Do not count the stitches and rows immediately, but allow the sample to rest for several hours or even over night. This will allow the stitches and rows to return to their basic form.

When your sample has rested and you are ready to count the stitches and rows, the KNITKING CONVERTA TAPE will do the counting for you without any counting on your part. Use the Tape as follows:

Measure the stitches with the TAPE, BETWEEN the 40 stitches marked with contrast waste yarn. Push the red marker on the Tape so that it points to 40 stitches on the Tape. Your stitch gauge to 5 cm (2 inches) will show in the red window on the Tape. To find the number of rows in 5 cm (2 inches), place the tape to measure over 60 rows, push the red marker to 60 on the Tape and your row gauge for 5 cm (2 inches) will show in the red window. If you do not get the correct stitch and row gauge in the first part of your sample, then try the other two.

If you do not own a KNITKING CONVERTA TAPE, you must mark a 5 cm (2 inch) square in the center of the knitting, then count the number of stitches and rows within the square.

DK 742

WOMAN'S TANK TOP & JACKET

SIZES: 7/8 (10/12) [14/16]

YARN: Euro Sport

GRAMS:
color 1 (Top) 150 150 200
color 2 (Jacket) 400 400 450

TENSION: 8 for Top
10 for Jacket

GAUGE: Top: 12 sts. 16 rows = 5 cm (2")
Jacket: 11 sts. 19 rows = 5 cm (2")

The Top is a Rib Pattern as given in the Instructions with bands K1, P1 Ribbing. The Jacket is an Eyelet Design. Punch your own Card or KNITTING machine owners use Card No. 419 in Volume 6 set of Punchcards. BE SURE TO PAY ATTENTION TO THE DIRECTIONS OF ARROWS on the Punchcard as you will move the Lace Carriage until the arrows show the directions of the Knit Carriage.

The Bands for Jacket are in Garter Stitch using hand knitting needles.

FINISHING: See General Instructions.

JACKET BANDS:

BACK: Pick up 116 sts. with hand knitting needles (3 1/2 mm) and work 10 rows Garter Stitch (5 ridges on the right side) Bind off. For Lower Front Bands, pick up 145 sts. For Front Bands, pick up 122 sts. and for Armhole Bands, pick up 102 sts. Work all bands the same as the back.

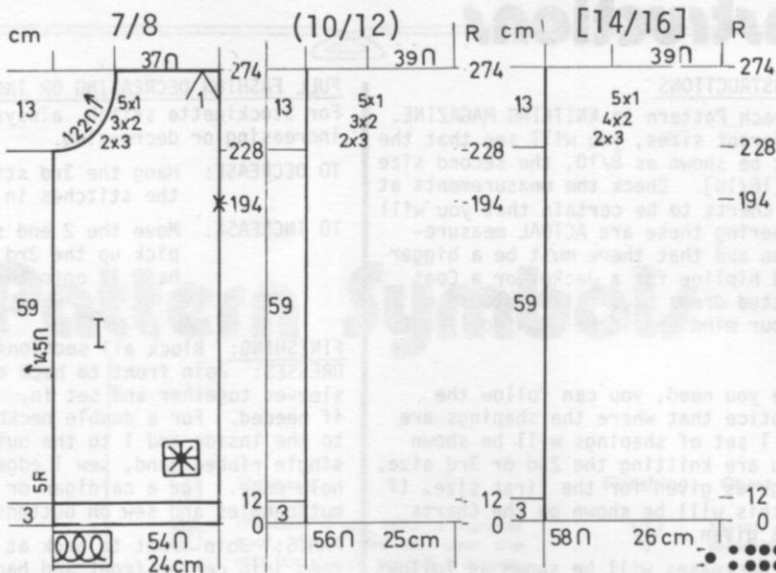

JACKET FRONT: Make 1, reverse

Cast on 54 (56) [58] sts. Set Counter at 12 and continue in Eyelet Design.

Mark Row 194 for armhole, then knit to Row 227.

SHAPE NECK: Bind off 3 sts. 2x, 2 sts. 3x, 1 st. 5x (same as first size).

[3 sts. 2x, 2 sts. 4x, 1 st. 5x After Row 274, bind off the remaining sts.



TANK TOP: Make 2 sections the same.

Cast on 106 (110) [116] sts. with color 1 and work 24 rows K1, P1 Ribbing.

Set into Pattern of 3 knit, 1 purl and continue to Row 124 (128) [132]. Return Pattern to K1, P1 Ribbing and knit to Row 136 (140) [144]. Bind off.

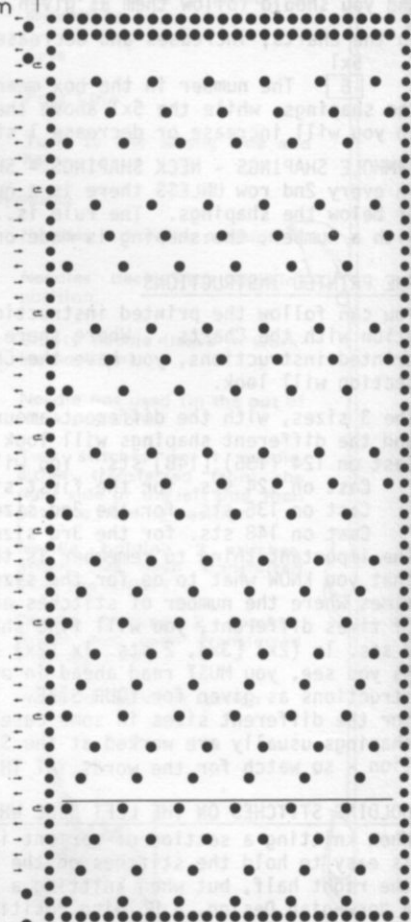

FOR ALTERNATE BANDS - You can pick up the stitches and work Stockinett stitch for a doubled hem - or any pattern stitch of your choice, but be sure to make a sample swatch first and make certain that the bands are smooth and flat.

JACKET BACK:

Cast on 116 (120) [120] sts. with waste yarn and knit 8 to 10 rows. Change to color 2 and work the Eyelet Design (Put Counter at 12). After Row 194, mark each side with a bit of waste yarn for armhole. Knit to Row 274. Remove the 42 neck sts. onto waste yarn and bind off shoulder sts. on each side.

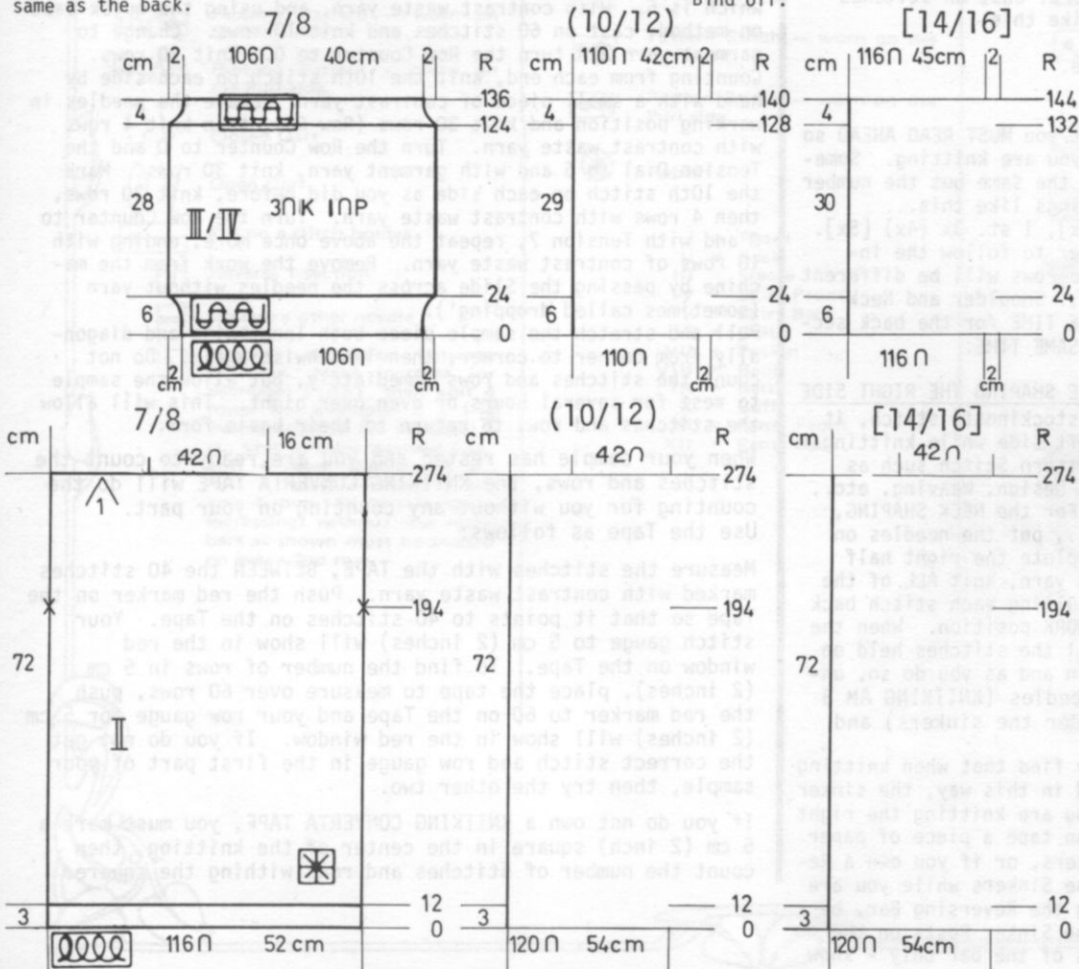

DK 744

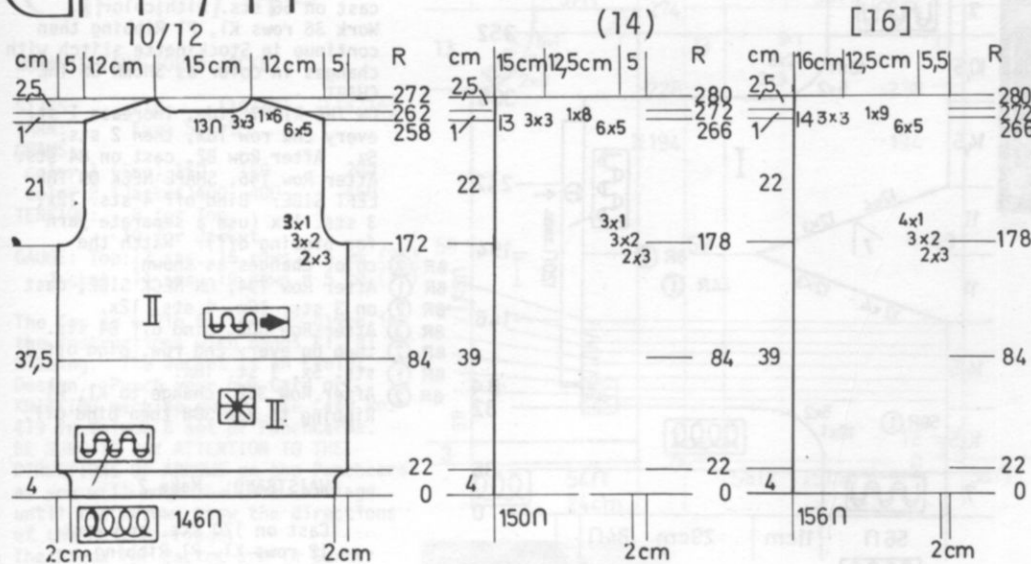

JACKET BACK:

Cast on 146 (150) [156] sts. and work 22 rows K1, P1 Ribbing. Continue in Eyelet Pattern to Row 84, then continue in Stockinette stitch.

After Row 172 (178) [178], SHAPE ARMHOLE: ON EACH SIDE, bind off 3 sts. 2x, 2 sts. 3x, 1 st. 3x. (3 sts. 2x, 2 sts. 3x, 1 st. 3x). [3 sts. 2x, 2 sts. 3x, 1 st. 4x]. After Row 258 (266) [266], SHAPE SHOULDER (and WATCH FOR NECK SHAPING). FOR SHOULDER: ON EACH SIDE, bind off 5 sts. 6x, 6 sts. 1x, (5 sts. 6x, 8 sts. 1x), [5 sts. 6x, 9 sts. 1x], AT THE SAME TIME, after Row 262 (272) [272], put half the sts. on the left into holding position and complete the right side first.

*ON NECK SIDE, bind off 13 (13) [14] sts. then bind off 3 sts. 3x for all sizes. Bring the needles on the left into working position, knit 1 row to the left side, turn the Row Counter back to 262 (272) [272] and complete the left half. Follow the instructions from * and don't forget to complete the shoulder shaping.

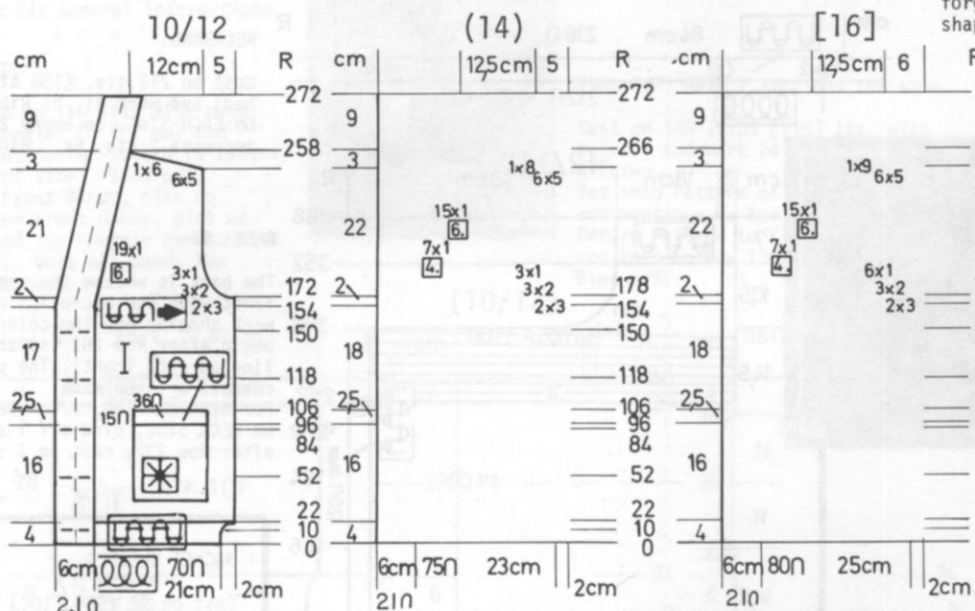

RIGHT FRONT BAND: Cast on 21 sts. and work Stockinette stitch. Knit 10 rows, Make BUTTONHOLES over needles 4 to 7 and 14 to 17 counting from the left edge. Knit 32 rows, and make BUTTONHOLES over same needles as before. REPEAT the BUTTONHOLES every 32 rows to Row 96. Remove these sts. onto waste yarn.

FOR FRONT - Cast on 70 (75) [80] sts. and work 22 rows K1, P1 Ribbing. Continue in Eyelet Pattern to Row 84. Continue in Stockinette stitch. Put 15 sts. on the left (right for left front) into holding position and over the next 36 sts. work 8 rows K1, P1 Ribbing (or you can remove the pocket sts. and work the ribbing later if you prefer). Bind off the pocket sts.. Hang the pocket lining sts. back onto machine over the empty needles and continue in Stockinette stitch. After Row 96, hang the front band sts. back onto the machine and continue over all the needles. Make 2 more BUTTONHOLES as you did before, 32 rows apart.

After Row 154 SHAPE NECK ON THE LEFT, (right for 2nd section). Hang the 21st stitch onto the 22nd st. and move the sts. over to fill the empty needle. REPEAT the decrease every 6th row 18x more (every 4th row 7x, every 6th row 15x [same as 2nd size], but AT THE SAME TIME, after Row 172 (178) [178], SHAPE ARMHOLE: Bind off 3 sts. 2x, 2 sts. 3x, 1 st. 3x, (3 sts. 2x, 2 sts. 3x, 1 st. 3x), [3 sts. 2x, 2 sts. 3x, 1 st. 6x], and SHAPE SHOULDER same as the back after Row 258 (266) [266]. Continue over the front band to Row 272. Remove the sts. onto waste yarn.

JACKET FRONT: Make 1, reverse 1 and omit buttonholes on left front band.

Work the pocket lining first, then part of the front band following the instructions. For pocket lining, cast on 36 sts. and work 40 rows Stockinette stitch. Remove onto waste yarn. Make a 2nd lining the same.

TOP: Make 2 sections the same.

Cast on 126 (132) [138] sts. and work 22 rows K1, P1 Ribbing. Continue in Eyelet Pattern. Knit to Row 128 (132) [136]. SHAPE ARMHOLE: ON EACH SIDE, bind off

3 sts. 1x, 2 sts. 2x, 1 st. 5x. (3 sts. 1x, 2 sts. 2x, 1 st. 6x). [3 sts. 2x, 2 sts. 2x, 1 st. 6x]. Knit to Row 146 (154) [154] then continue in Stockinette stitch to Row 178 (186) [186]. Bind off.

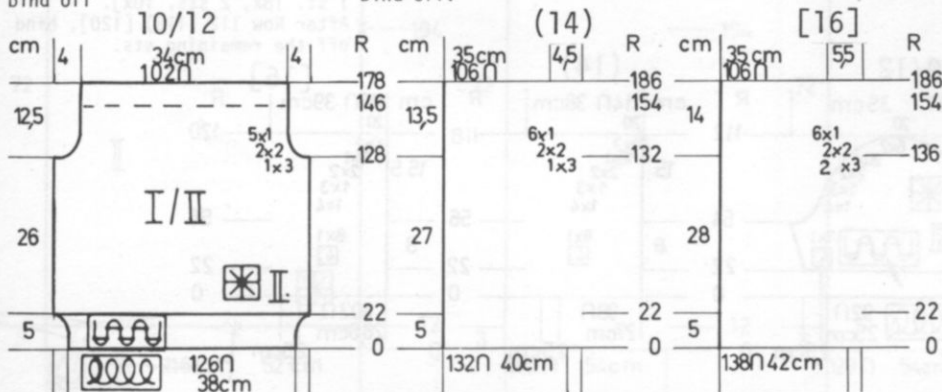

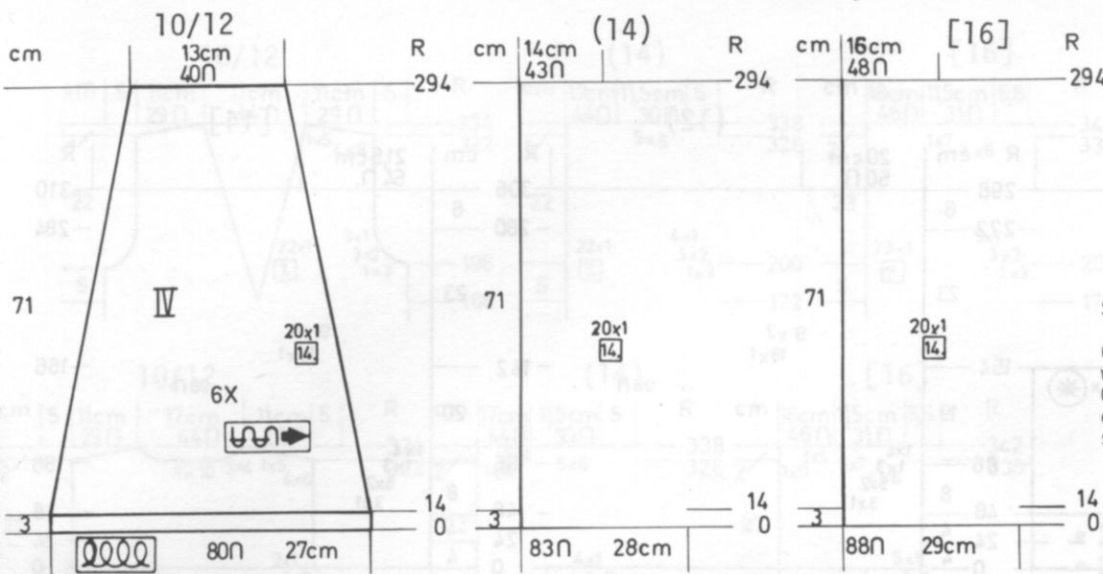

SKIRT: IV Make 6 sections.
 Cast on 80 (83) [88] sts. and work Stockinette stitch.
 ON EACH SIDE, decrease 1 st. every 14th row 20x for all sizes. After Row 294, bind off.

DK 745

WOMAN'S JACKET & PULLOVER WITH STRAPS.

SIZES: 8/10 (12) [14]
 YARN: Amore
 GRAMS:
 color 1 550 550 600
 color 2 100 100 150
 color 3 50 50 100
 TENSION: 7 to 9
 GAUGE:
 Pull: 14 sts. 22 rows = 5 cm (2")
 Jacket: 12 sts. 24 rows = 5 cm (2")



The Pullover is a Norwegian Design. The Jacket is knitted sideways on the machine in a combination of Stockinette stitch, Tuck and an Eyelet Design. Sleeve bands of Jacket and bands of Pullover are Ribbed.

FINISHING: See General Instructions. Sew neckband strips together and place seam at center back of jacket. Sew 70 sts. on each side of center seam to neckline of jacket (see picture). Sew straps on Pullover.

PULLOVER STRAPS: Make 2.
 Cast on 19 sts. with color 2 and work K1, P1 Ribbing for 30 cm (12"). Bind off.

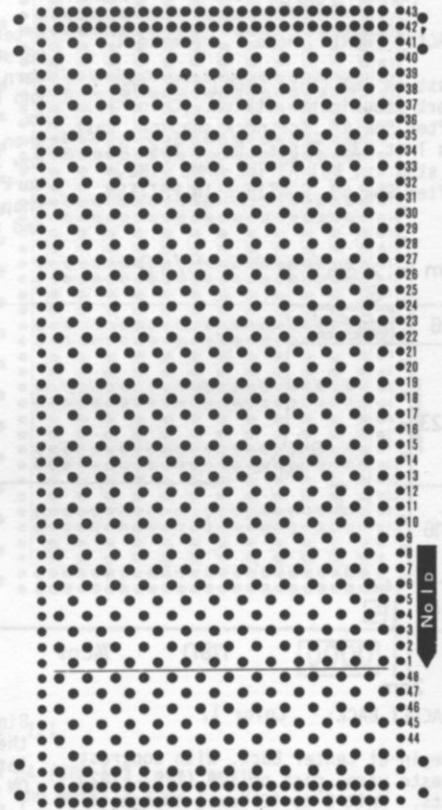
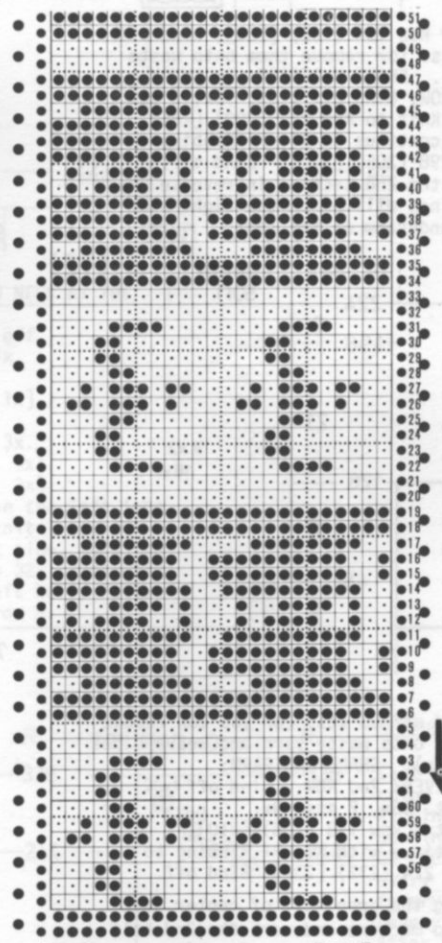

PULLOVER: Make 2 sections the same.

Cast on 124 (126) [126] sts. with color 2 and work 28 rows K1, P1 Ribbing. Continue in the Norwegian Design following the chart for the changes in color. After Row 138 (142) [146], continue in K1, P1 Ribbing with color 2 to Row 150 (154) [158]. Bind off.

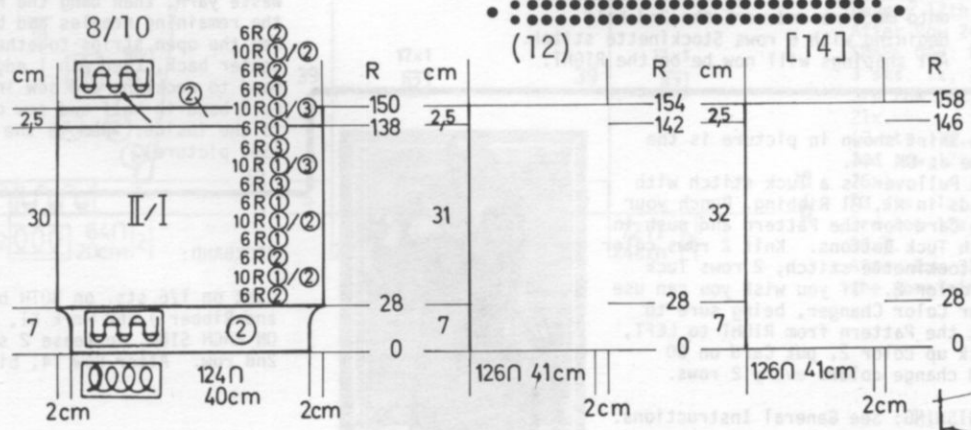

JACKET PATTERN - 830 Machine owners use Card No. 1 of your original set. Leave on STOP throughout.
 *12 rows Stockinette stitch.
 4 rows Tuck.
 2 rows Stockinette stitch.
 1 row Eyelets.
 2 rows Stockinette stitch.
 4 rows Tuck.
 REPEAT FROM * for Pattern.



DK 745

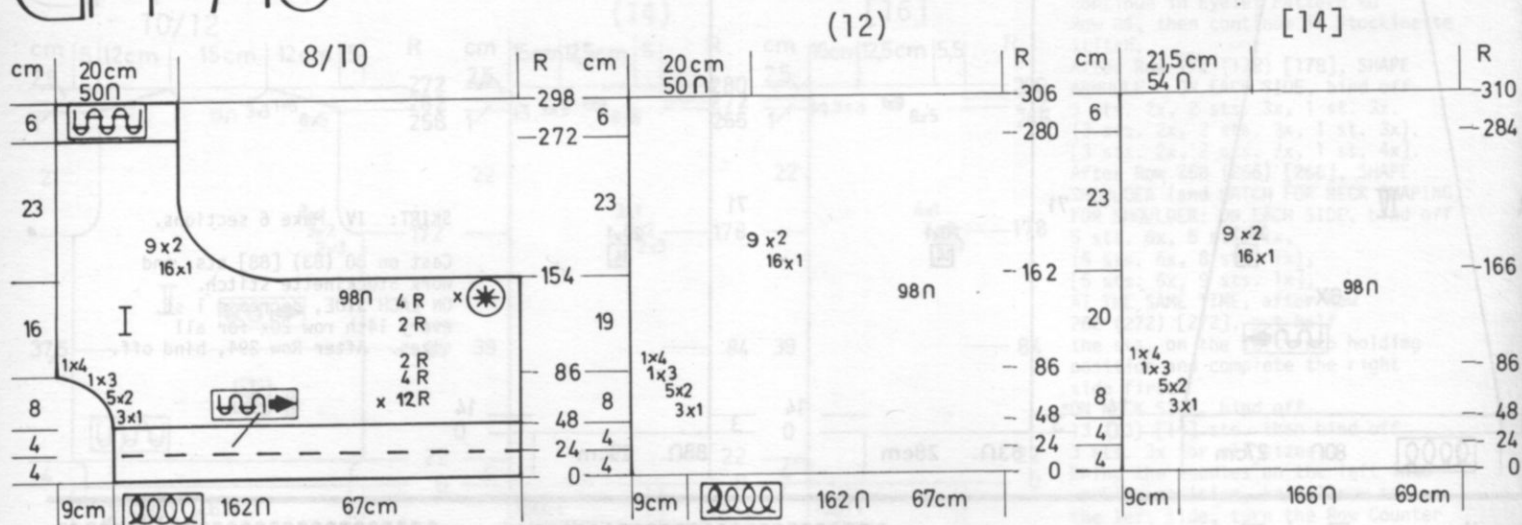

JACKET FRONT: Make 1, reverse 1.

Cast on 162 (162) [166] sts. and work Stockinette stitch. (Color 1). After Row 47, for neck shaping, cast on 1 st. 3x, 2 sts. 5x, 3 sts. 1x, 4 sts. 1x, BUT AT THE SAME TIME, after Row 60, CONTINUE IN PATTERN.

After Row 154 (162) [166], bind off 98 sts. (or remove them onto waste yarn). SHAPE UNDERARM: ON EVERY 2nd ROW, bind off 1 st. 16x, 2 sts. 9x. Knit to Row 272 (280) [284], then continue in K1, P1 Ribbing to Row 298 (306) [310]. Bind off. Work the 2nd section in reverse. Neck shapings will be on the right side and underarm on the left.

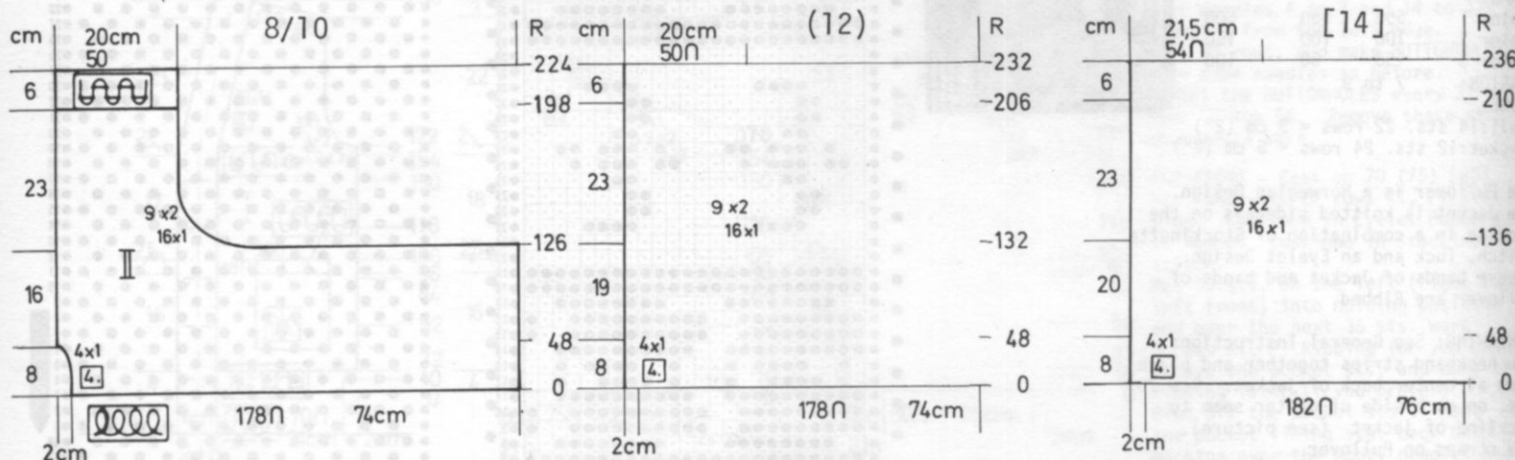

JACKET BACK: Color 1.

Begin at center Back. With contrast waste yarn, cast on 178 (178) [182] sts. Knit 8 to 10 rows, change to garment yarn and put Counter at 0. Begin with 6 rows Stockinette stitch (instead of 12) then continue with Pattern. AT THE SAME TIME, on every 2nd row, cast on 1 st. 4x on the left side (right for 2nd half) for the neck shaping. Knit to Row 126 (132) [136].

Bind off 98 sts. (or you can remove them onto waste yarn and weave sides later). SHAPE UNDERARM: ON EVERY 2nd ROW, bind off 1 st. 16x, 2 sts. 9x. Knit to Row 198 (206) [210]. Continue with K1, P1 Ribbing to Row 224 (232) [236]. Bind off.

Hang the open sts. of center back onto machine and work the 2nd half beginning with 6 rows Stockinette stitch. All shapings will now be on the RIGHT.

JACKET NECK & FRONT BANDS: Make 2.

Cast on 200 sts. with waste yarn as you did for back. After knitting 8 to 10 rows, change to color 1 and put counter at 0. Knit 48 rows Stockinette stitch. Remove 70 sts. at one side onto waste yarn, then hang the hem over the remaining needles and bind off. Sew the open strips together at center back, then pin 1 edge of band to neckline and sew in place. Fold band in half and sew other edge to the inside. Remove the waste yarn. (See picture).

DK 746

WOMAN'S PULLOVER

SIZES: 10/12 (14) [16]
 YARN: Fortissima
 GRAMS:
 color 1 300 300 350
 color 2 200 200 250
 TENSION: 7 to 9
 GAUGE: 13 sts. 29 rows = 5 cm (2")

The Skirt shown in picture is the same as DK 744. The Pullover is a Tuck stitch with bands in K1, P1 Ribbing. Punch your own Card for the Pattern and push in both Tuck Buttons. Knit 2 rows color 1 Stockinette stitch, 2 rows Tuck in color 2. If you wish you can use your Color Changer, being sure to set the Pattern from RIGHT to LEFT, pick up color 2, put Card on GO and change colors every 2 rows.

FINISHING: See General Instructions.



NECKBAND:

Cast on 176 sts. on BOTH beds (Knitter and Ribber) and work K1, P1 Ribbing. ON EACH SIDE, increase 2 sts. every 2nd row. After Row 14, bind off.

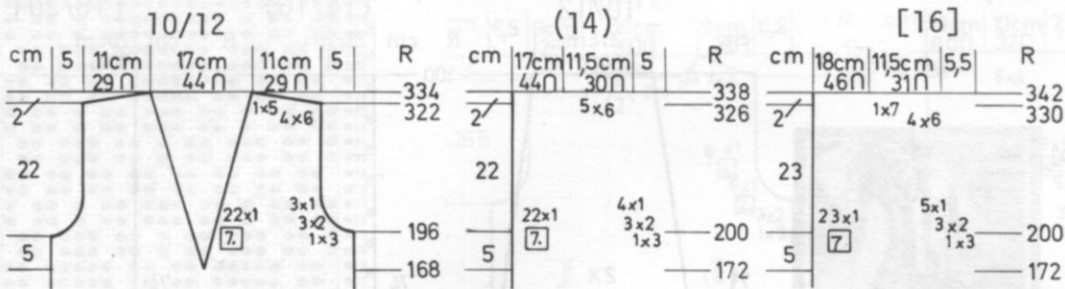

FRONT: I

Work the front the same as the back to Row 168 (172) [172]. Put half the sts. on the left into holding position and complete the right side first. *ON NECK SIDE, decrease 1 st. every 7th row 22x (22x) [23x] BUT AT THE SAME TIME, after Row 196 (200) [200], SHAPE ARMHOLE SAME AS THE BACK, and after Row 322 (326) [330] SHAPE SHOULDER same as the back. Bring the needles on the left into working position, knit 1 row in Pattern to the left side, turn the Row Counter back to 168 (172) [172] and complete the left half. Follow the instructions from *.

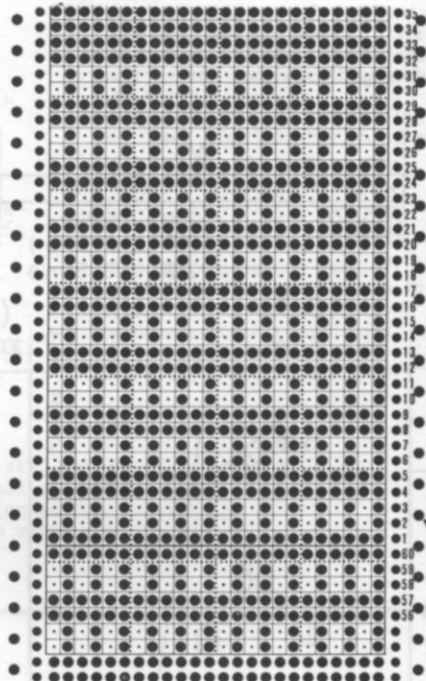
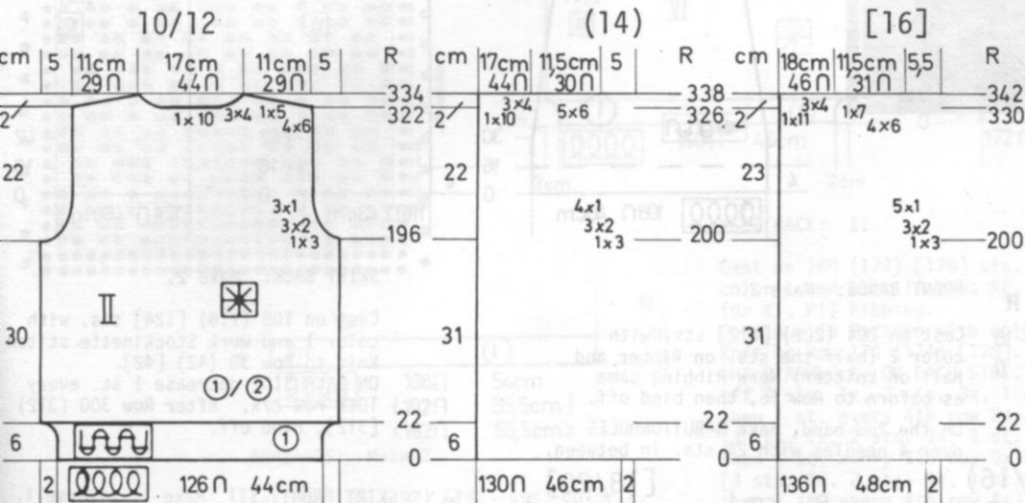

BACK: II

Cast on 126 (130) [136] sts. with color 1 and work 22 rows K1, P1 Ribbing. Continue in Pattern. Knit to Row 196 (200) [200]. SHAPE ARMHOLE: ON EACH SIDE, bind off 3 sts. 1x, 2 sts. 3x, 1 st. 3x. (3 sts. 1x, 2 sts. 3x, 1 st. 4x). [3 sts. 1x, 2 sts. 3x, 1 st. 5x]. Knit to Row 322 (326) [330]. Put half the sts. on the left into holding position and complete the right side first.

*SHAPE SHOULDER AND NECK AT THE SAME TIME. FOR SHOULDER, bind off 6 sts. 4x, 5 sts. 1x, (6 sts. 5x), [6 sts. 4x, 7 sts. 1x], FOR NECK: Bind off 10 sts. 1x, 4 sts. 3x. (10 sts. 1x, 4 sts. 3x). [11 sts. 1x, 4 sts. 3x]. Bring the needles on the left into working position, knit 1 row in Pattern to the left side, turn the Row Counter back to 322 (326) [330] and complete the left half. Follow the instructions from *.

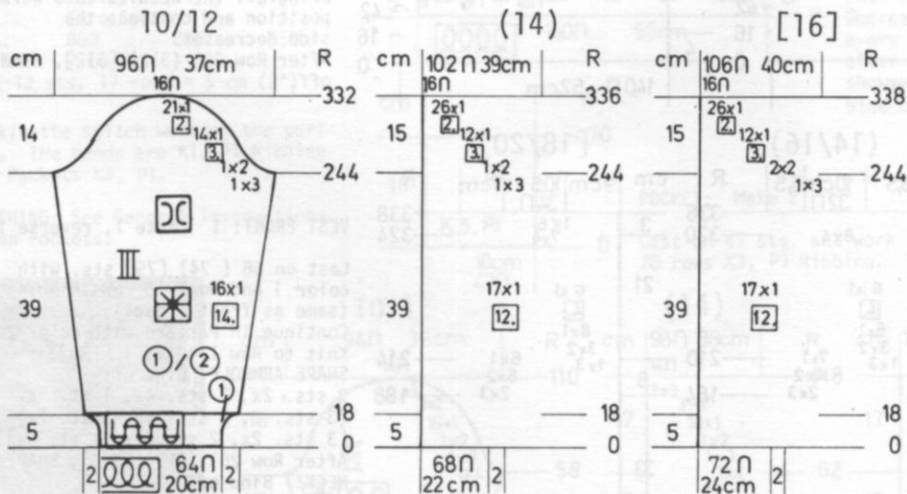

SLEEVES: III

Cast on 64 (68) [72] sts. with color 1 and work 18 rows K1, P1 Ribbing. Continue in Pattern. ON EACH SIDE, increase 1 st. every 14th row 16x. (every 12th row 17x). [every 12th row 17x]. After Row 244 (244) [244], SHAPE CAP: ON EACH SIDE, bind off 3 sts. 1x, 2 sts. 1x, 1 st. every 3rd row 14x, 1 st. every 2nd row 21x. (3 sts. 1x, 2 sts. 1x, 1 st. every 3rd row 12x, 1 st. every 2nd row 26x). [3 sts. 1x, 2 sts. 2x, 1 st. every 3rd row 12x, 1 st. every 2nd row 26x]. After Row 332 (336) [338], bind off the remaining sts.

dk 747

WOMAN'S SKIRT & VEST

SIZES: 10/12 (14/16) [18/20]
YARN: Fortissima
GRAMS:
 color 1 650 650 700
 color 2 200 200 200
TENSION: 7 to 9
GAUGE:
 Stock: 13 1/2 sts, 20 rows = 5 cm (2")
 Pat: 16 sts, 26 rows = 5 cm (2")



The Vest is in a Tuck Pattern. Punch your own card. Skirt is Stockinette stitch. Bands are Ribbed.

FINISHING: See General Instructions. Skirt: Sew seams then make pleat on each side. Sew on Waistband, pull elastic through casing. Sew down pocket lining and tack pocket band at each edge.

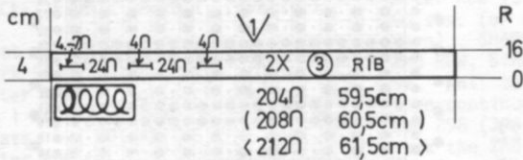
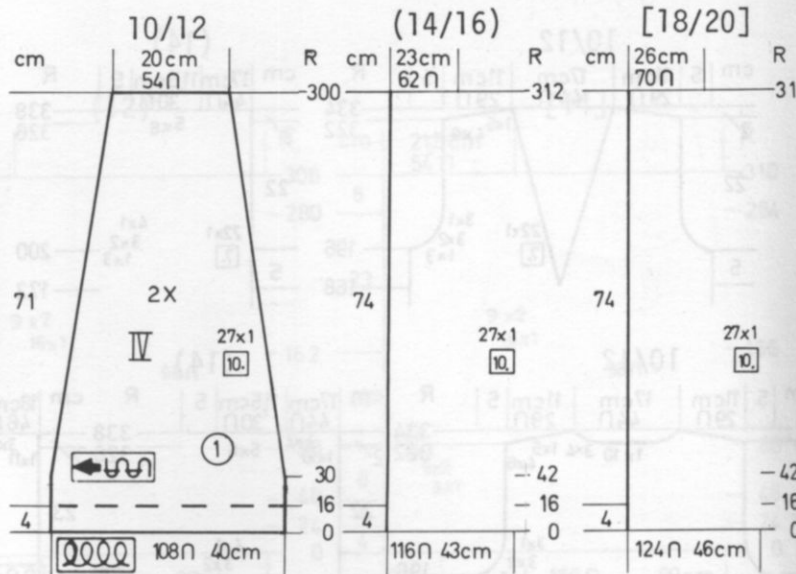

FRONT BANDS: Make 2.

Cast on 204 (208) [212] sts. with color 2 (half the sts. on Ribber and half on knitter) Work Ribbing same as before to Row 16, then bind off.

On the 2nd band, make 5 **BUTTONHOLES** over 4 needles with 24 sts. in between.

SKIRT BACK: Make 2.

Cast on 108 (116) [124] sts. with color 1 and work Stockinette stitch. Knit to Row 30 (42) [42]. ON EACH SIDE decrease 1 st. every 10th row 27x. After Row 300 (312) [312], bind off.

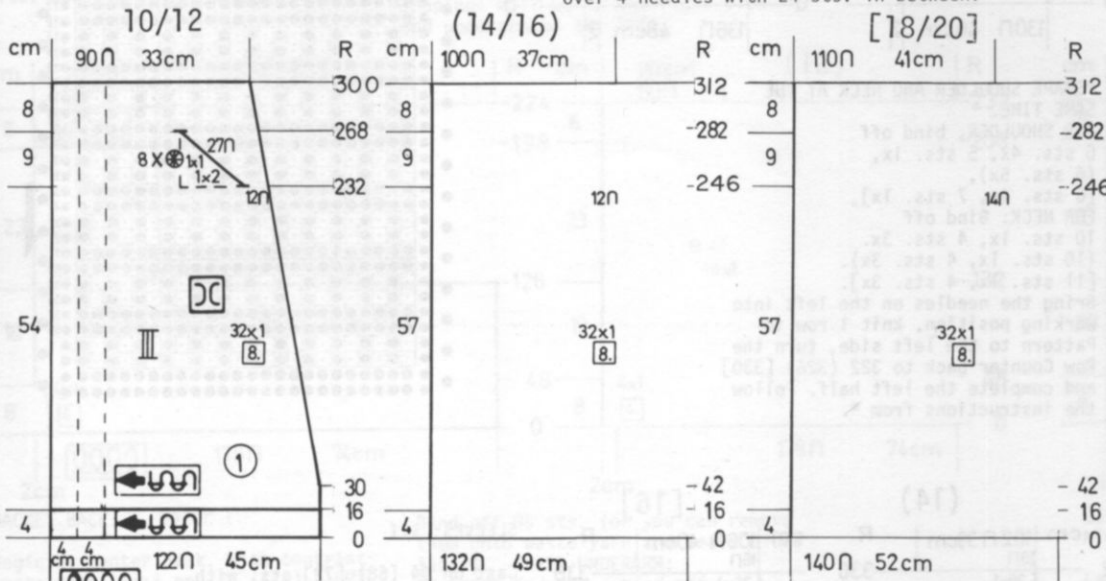

SKIRT FRONT: III Make 1, reverse 1.

Cast on 122 (132) [140] sts. with color 1 and work Stockinette stitch. After Row 30 (42) [42] ON SIDE EDGE. DECREASE 1 st. EVERY 8TH ROW 32x BUT AT THE SAME TIME, after Row 232 (246) [246], divide for slit. Put 12 (12) [14] sts. on the right (left) into holding position. ON THE RIGHT (left)*decrease 2 sts. every 2nd row 1x, then 1 st. 1x and REPEAT from * 8x more. After Row 268 (282) [282], put these sts. into holding position. Bring the 12 (12) [14] sts. into working position, turn the Row Counter back to 232 (246) [246] and cast on 27 sts. on INNER EDGE. Knit to Row 268 (282) [282]. Bring all the needles into working position and continue the side decreases. After Row 300 (312) [312], bind off.

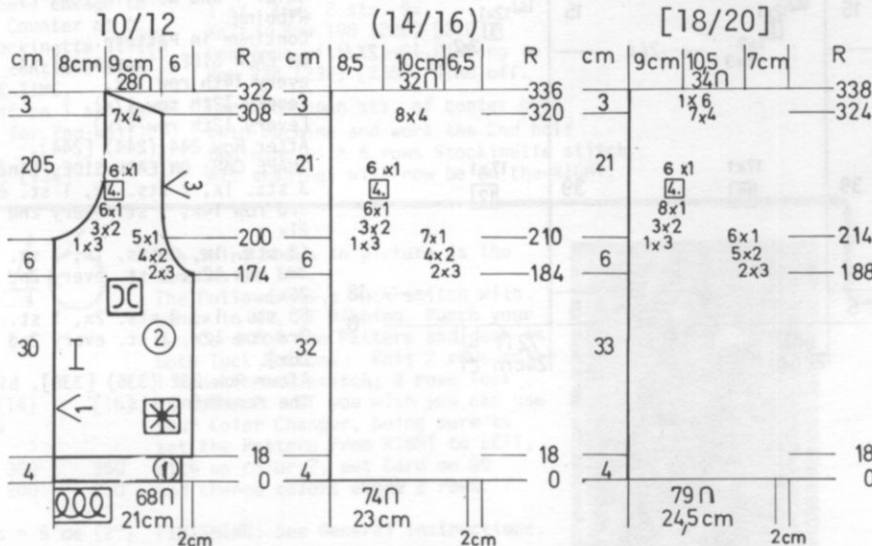

VEST FRONT: I Make 1, reverse 1.

Cast on 68 (74) [79] sts. with color 1 and work 18 rows Ribbing (same as front & back). Continue in Pattern with color 2. Knit to Row 174 (184) [188]. **SHAPE ARMHOLE:** Bind off 3 sts. 2x, 2 sts. 4x, 1 st. 5x. (3 sts. 2x, 2 sts. 4x, 1 st. 7x) [3 sts. 2x, 2 sts. 5x, 1 st. 6x]. After Row 201 (211) [215], **SHAPE NECK:** Bind off 3 sts. 1x, 2 sts. 3x, 1 st. 6x then 1 st. every 4th row 6x. [Same as first size]. [3 sts. 1x, 2 sts. 3x, 1 st. 8x then 1 st. every 4th row 6x]. After Row 308 (320) [324], **SHAPE SHOULDER** same as the back.

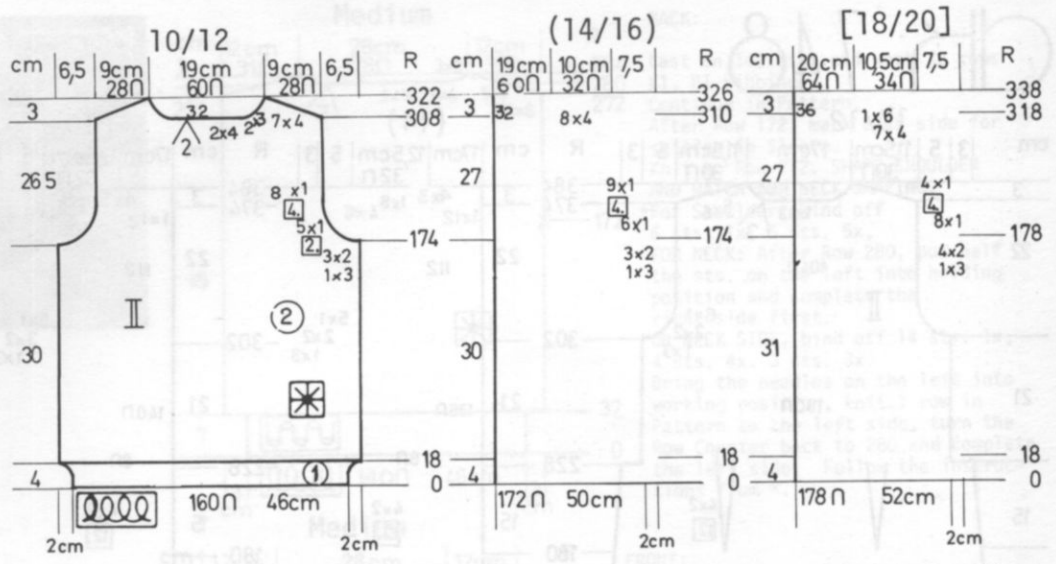
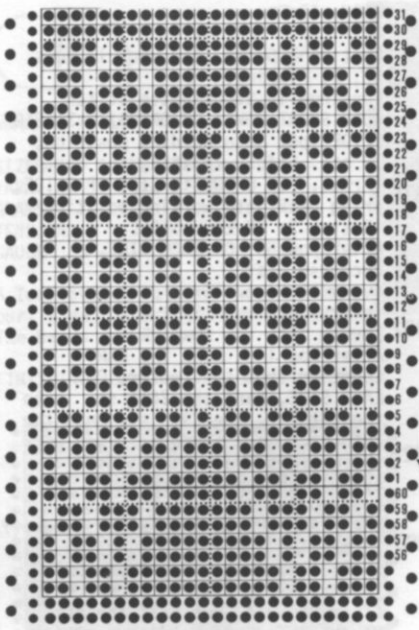

VEST BACK: II

Cast on 160 (172) [178] sts. with color 1 and work 18 rows K2, P2 (or K1, P1) Ribbing. Continue in Pattern with color 2. Knit to Row 174 (174) [178]. SHAPE ARMHOLE: ON EACH SIDE, bind off 3 sts. 1x, 2 sts. 3x, 1 st. 5x then 1 st. every 4th row 8x. (3 sts. 1x, 2 sts. 3x, 1 st. 6x, then 1 st. every 4th row 9x). [3 sts. 1x, 2 sts. 4x, 1 st. 8x, then 1 st. every 4th row 4x]. After Row 308 (310) [318], bind off the center 32 (32) [36] sts. put

the needles on the left into holding position and complete the right side first. *SHAPE SHOULDER AND NECK AT THE SAME TIME. FOR SHOULDER, bind off 4 sts. 7x, (4 sts. 8x), [4 sts. 7x, 6 sts. 1x], FOR NECK, bind off 4 sts. 2x, 3 sts. 2x, for all sizes. Bring the needles on the left into working position, knit 1 row in Pattern to the left side, turn the Row Counter back to 308 (310) [318] and complete the left half. Follow the instructions from *.

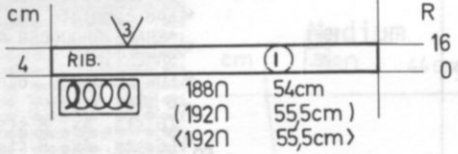

ARMBANDS: Make 2.

Cast on 188 (192) [192] sts. color 2. Work Ribbing same as before to Row 16 then bind off.

SKIRT WAISTBAND

Cast on 180 (186) [196] sts. with color 1 and work Stockinette stitch. After Row 28, bind off (or you can remove the sts. onto waste yarn if you prefer).

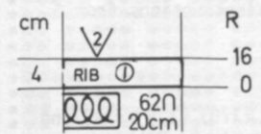

BACK NECK BAND:

Cast on 62 sts. with color 2 and work 16 rows Ribbing same as before then bind off.

DK 748

WOMAN'S DRESS

SIZES: 10/12 (14) [16]
 YARN: Euro Sport
 GRAMS: 800 800 850
 TENSION: 7 to 9
 GAUGE: 13 sts. 17 rows = 5 cm (2")

Stockinette stitch worn on the purl side. The bands are K1, P1 Ribbing with Pockets K3, P1.

FINISHING: See General Instructions. Sew on Pockets.

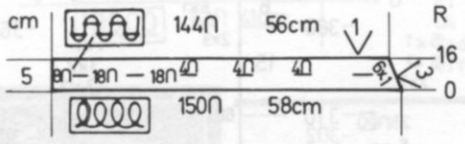

FRONT BANDS: Make 2 but omit Buttonholes in 2nd section.

Cast on 150 sts. and work in Ribbing. Decrease 1 st. on the Right (left) every 2nd row 6x and AT THE SAME TIME, after Row 8, make BUTTONHOLES as shown on the Chart. After Row 16, bind off.

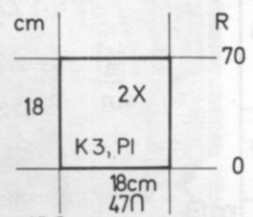

POCKET: Make 2.

Cast on 47 sts. and work 70 rows K3, P1 Ribbing. Bind off.



SLEEVES: III

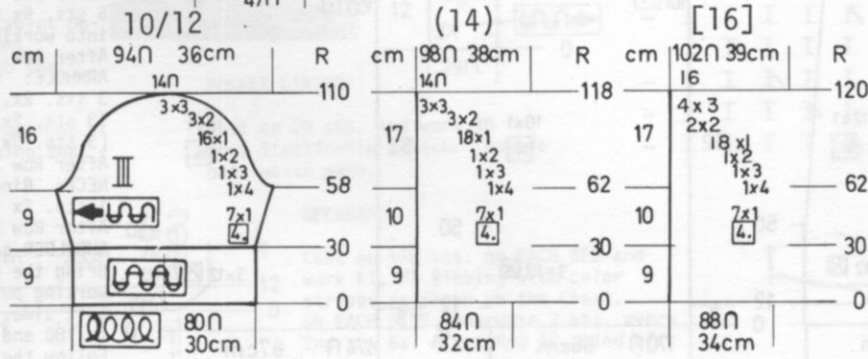

Cast on 80 (84) [88] sts. and work 30 rows Ribbing as you did before. Continue in Stockinette stitch. ON EACH SIDE, increase 1 st. every 4th row 7x. After Row 58 (62) [62], SHAPE CAP: ON EACH SIDE, bind off 4 sts. 1x, 3 sts. 1x, 2 sts. 1x, 1 st. 16x, 2 sts. 3x, 3 sts. 3x. (4 sts. 1x, 3 sts. 1x, 2 sts. 1x, 1 st. 18x, 2 sts. 3x, 3 sts. 3x). [4 sts. 1x, 3 sts. 1x, 2 sts. 1x, 1 st. 18x, 2 sts. 2x, 3 sts. 4x]. After Row 110 (118) [120], bind off the remaining sts.

dk 748

BACK: II

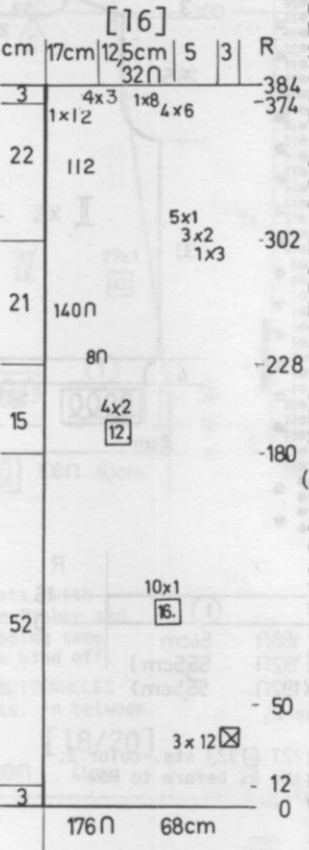
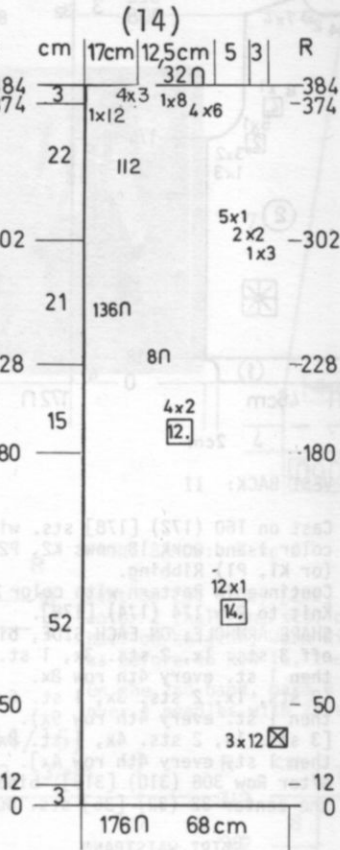
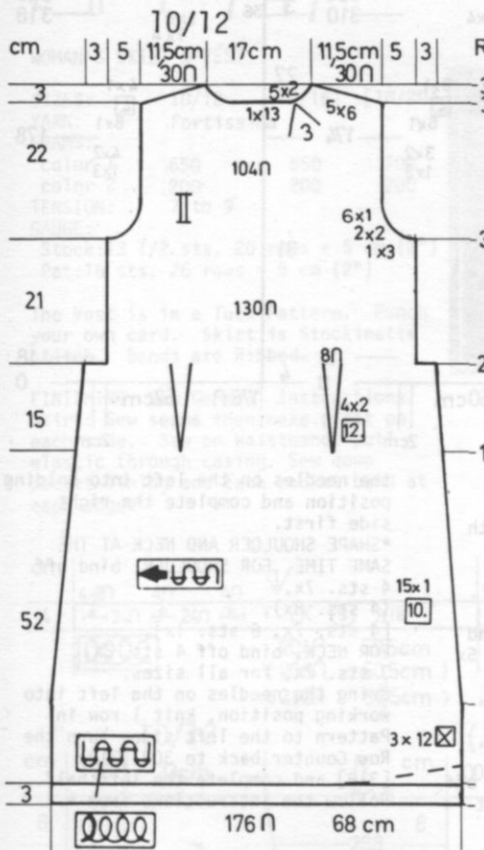

Cast on 176 sts. and work 12 rows K1, P1 Ribbing. Continue in Stockinette stitch. WORK SHORT ROWS: ON OPPOSITE SIDE OF SLIDE, put into holding position, 36 sts. before knitting the next 2 rows. ON OPPOSITE SIDE OF SLIDE, bring back into working position 12 sts. 3x ON EACH SIDE. After Row 50, ON EACH SIDE, decrease 1 st. every 10th row 15x. (every 14th row 12x). [every 16th row 10x]. After Row 180, WORK THE DARTS. Counting from the center, ON EACH SIDE, hang the 26th st. onto the 27th st. the 29th st. onto the 28th st. Mark these sts. and work the decreases directly above every 12th row 3x more. Knit to Row 302. SHAPE ARMHOLE: ON EACH SIDE, bind off 3 sts. 1x, 2 sts. 2x, 1 st. 6x. (3 sts. 1x, 2 sts. 2x, 1 st. 5x). [3 sts. 1x, 2 sts. 3x, 1 st. 5x]. After Row 374, Put half the sts. on the left into holding position and complete the right side first. *SHAPE SHOULDER AND NECK AT THE SAME TIME. FOR SHOULDER, bind off 6 sts. 5x, (6 sts. 4x, 8 sts. 1x), [6 sts. 4x, 8 sts. 1x], FOR NECK, bind off 13 (12) [12] sts. 1x, then 2 sts. 5x (3 sts. 4x) [3 sts. 4x]. Bring the needles on the left into working position, knit 1 row to the left side, turn the Row Counter back to 374 and complete the left half. Follow the instructions from *.

NECKBAND:

Cast on 144 sts. and work K1, P1 Ribbing. ON EACH SIDE, decrease 1 st. every 2nd row 6x. After Row 16, bind off.

FRONT: I

Cast on 170 (170) [174] sts. and work 12 rows K1, P1 Ribbing. Continue in Stockinette stitch. Work the SHORT ROWS ON EACH SIDE, same as you did for the Back. After Row 50, ON EACH SIDE, decrease 1 st. every 12th row 12x, (every 14th row 10x), [every 14th row 10x]. After Row 180, bind off the center 10 sts. (or you can remove them onto a stitch holder), and complete the right side first. Put the needles on the left into holding position. *WORK THE DART the same as you did for the back. After Row 228, ON SIDE EDGE, increase 1 st. every 18th row 4x. After Row 291 (291) [295], WORK THE BUST DART: ON OPPOSITE SIDE OF SLIDE put into holding position, 5 sts. 5x then bring them all back into working position. After Row 310 (310) [314], SHAPE ARMHOLE: Bind off 3 sts. 2x, 2 sts. 3x, 1 st. 5x. (3 sts. 2x, 2 sts. 3x, 1 st. 5x). [3 sts. 3x, 2 sts. 3x, 1 st. 4x]. After Row 359 (359) [363], SHAPE NECK: Bind off 3 sts. 2x, 2 sts. 3x, 1 st. 5x for all sizes. After Row 382 (382) [386], SHAPE SHOULDER same as the back. Bring the needles on the left into working position, knit 1 row to the left side, turn the Row Counter back to 180 and complete the left half. Follow the instructions from *.

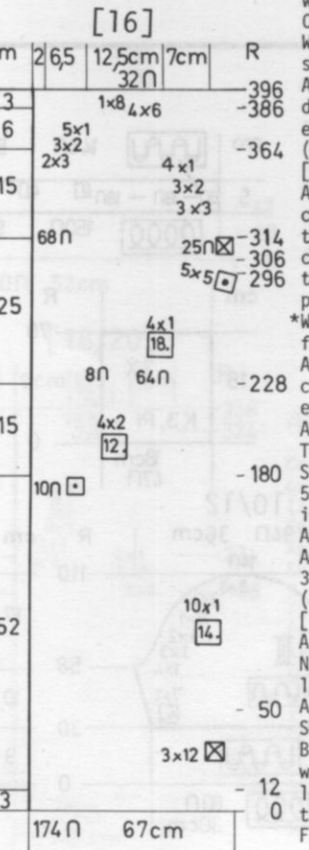
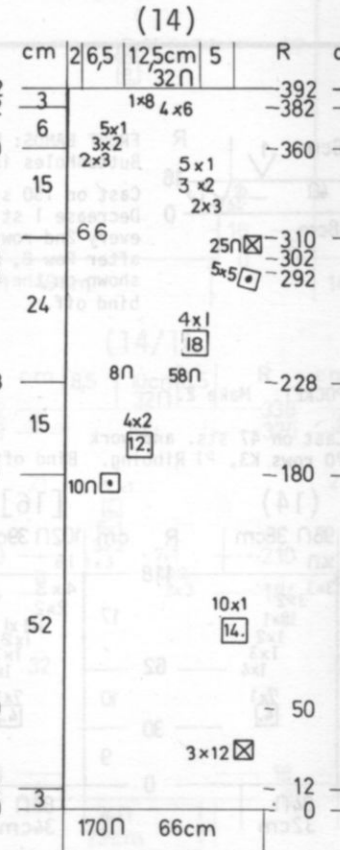
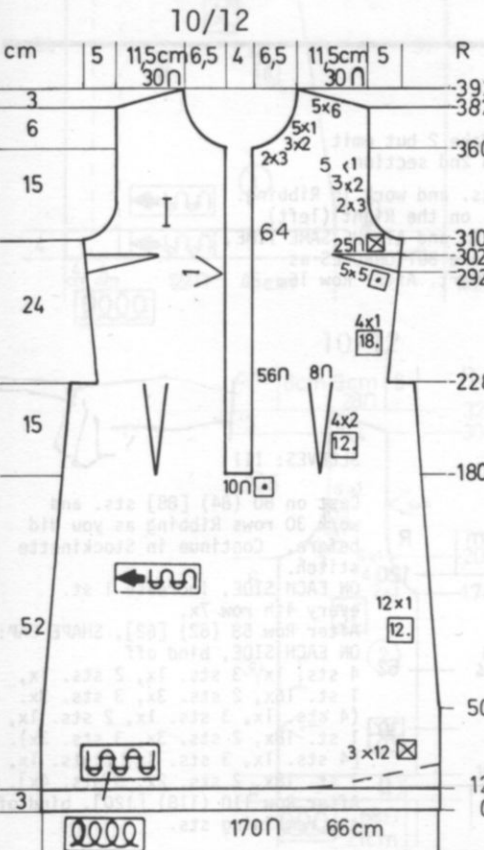

dk 749

WOMAN'S PULLOVER

SIZES: MEDIUM (1 size)
 YARN: Euro Sport
 GRAMS: 450
 TENSION: 7 to 9
 GAUGE: 13 sts. 22 rows = 5 cm (2")

A Tuck Stitch Pattern worn on the purl side. Punch your own Card. The bands are Ribbed.

FINISHING: See General Instructions.

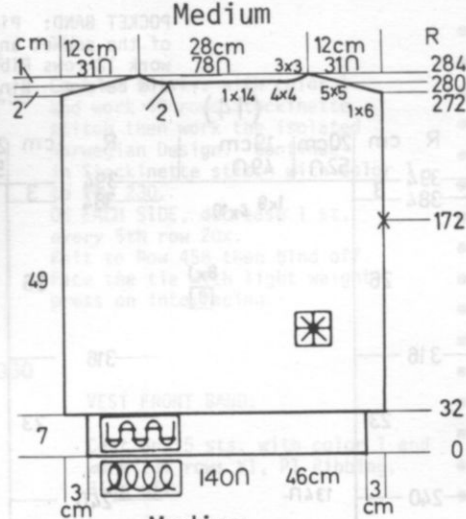

BACK:

Cast on 140 sts. and work 32 rows K1, P1 Ribbing. Continue in Pattern. After Row 172, mark each side for setting in Sleeve. Knit to Row 272. SHAPE SHOULDER AND WATCH FOR NECK SHAPING. *For Shoulder, bind off 6 sts. 1x, 5 sts. 5x, FOR NECK: After Row 280, put half the sts. on the left into holding position and complete the right side first. ON NECK SIDE, bind off 14 sts. 1x, 4 sts. 4x. 3 sts. 3x. Bring the needles on the left into working position, knit 1 row in Pattern to the left side, turn the Row Counter back to 280 and complete the left side. Follow the instructions from *.

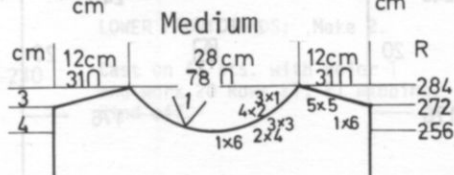
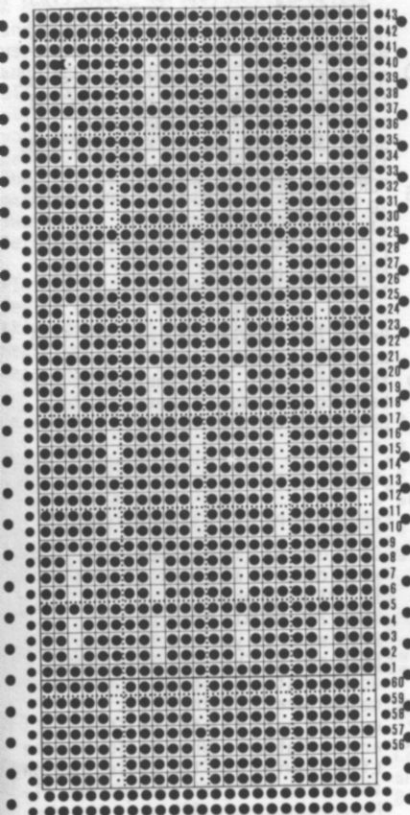

FRONT:

Work the front the same as the back to Row 256. Put half the sts. on the left into holding position and complete the right side first. *ON NECK SIDE, bind off 6 sts. 1x, 4 sts. 2x, 3 sts. 3x, 2 sts. 4x, 1 st. 3x and SHAPE SHOULDER same as the back after Row 272. Bring the needles on the left into working position, knit 1 row in Pattern to the left side, turn the Row Counter back to 256 and complete the left half. Follow the instructions from *.

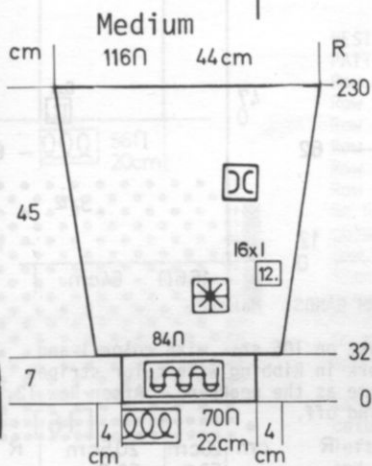

SLEEVES:

Cast on 70 sts. and work 32 rows K1, P1 Ribbing. INCREASE 14 sts. evenly across and continue in Pattern ON EACH SIDE, increase 1 st. every 12th row 16x. After Row 230, remove the sts. onto waste yarn (or you can bind off).

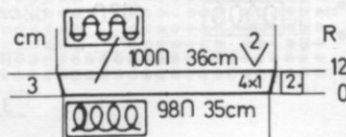

BACK NECKBAND:

Cast on 98 sts. and work the same as front Neckband.

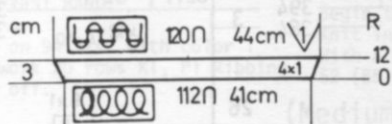

FRONT NECKBAND:

Cast on 112 sts. and work K1, P1 Ribbing. ON EACH SIDE, increase 1 st. every 2nd row 4x. After Row 12, bind off.

dk 750

WOMAN'S DRESS

SIZES: 10/12 (14) [16]
 YARN: Euro Sport
 GRAMS: color 1 650 650 700
 color 2 50 50 50
 TENSION: 7 to 9
 GAUGE: 13 sts. 16 rows = 5 cm (2")

Stockinette stitch with an Eyelet Design on each side of the Front. Follow the Line Drawing. Rib the Bands.

FINISHING: See General Instructions. Sew on Bands. Sew Pocket Lining and tack Ribbing of Pocket.

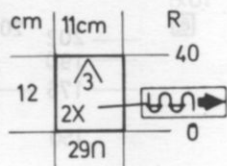

POCKET LINING:

Cast on 29 sts. and work 40 Rows Stockinette stitch. Remove onto waste yarn.

NECKBAND:

Cast on 176 sts. on EACH BED and work K1, P1 Ribbing with color stripes as shown on the Chart. ON EACH SIDE, increase 2 sts. every 2nd row 6x. After Row 12, bind off.

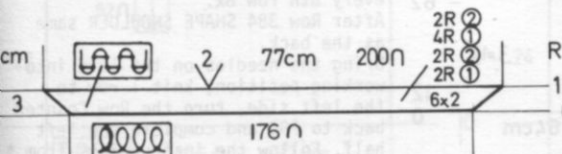
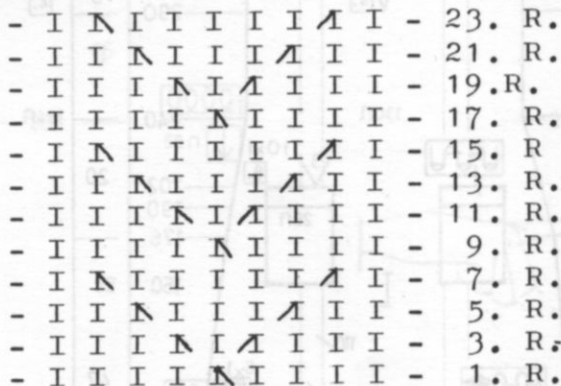

dk 750

10/12

(14)

POCKET BAND: Pick up the open sts. of the pocket and with color 1 work 12 rows Ribbing same as you did before. Bind off.

[16]

BACK: II

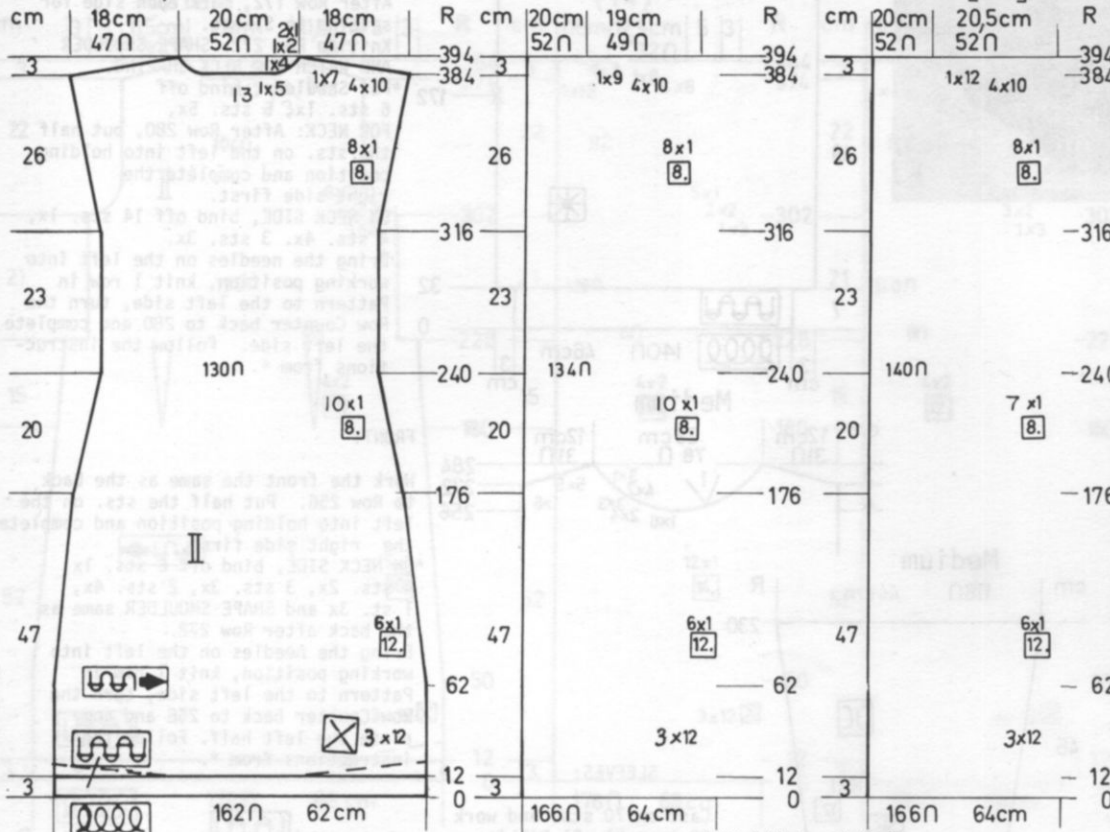

Cast on 162 (166) [166] sts. with color 1 and work 12 rows K1, P1 Ribbing.
Continue in Stockinette stitch.
WORK SHORT ROWS: ON OPPOSITE SIDE OF SLIDE, put into holding position 36 sts. before knitting the next 2 rows. ON OPPOSITE SIDE OF SLIDE bring back into working position 12 sts. 3x ON EACH SIDE.
After Row 62, ON EACH SIDE, decrease 1 st. every 12th row 6x, then 1 st. every 8th row 10x (10x) [7x]. Knit to Row 316.
ON EACH SIDE, increase 1 st. every 8th row 8x.
After Row 384, put half the sts. on the left into holding position and complete the right side first.
*SHAPE SHOULDER AND NECK AT THE SAME TIME.
FOR SHOULDER, bind off 10 sts. 4x, 7 sts. 1x, (10 sts. 4x, 9 sts. 1x, [10 sts. 4x, 12 sts. 1x]).
FOR NECK, bind off for all sizes, 13 sts. 1x, 5 sts. 1x, 4 sts. 1x, 2 sts. 1x, 1 st. 2x.
Bring the needles on the left into working position, knit 1 row to the left side, turn the Row Counter back to 384 and complete the left half. Follow the instructions from

FRONT: I

Make the Pocket Linings first.

Cast on 162 (166) [166] sts. with color 1 and work 12 rows K1, P1 Ribbing.
WORK THE SHORT ROWS ON EACH SIDE same as you did for the back and AT THE SAME TIME, set up the Pattern - 58 sts. in the center are Stockinette stitch and the next 11 sts. ON EACH SIDE are in Pattern. When following the Line Drawing for the Eyelet Design, the first and last sts. of the 11 Pattern sts. are Rib sts. and you must drop them down and latch them up OR YOU CAN LEAVE THESE STS. OUT OF WORK for a simulated Rib stitch which is easier.
Continue the Pattern on each side throughout.
After Row 62, ON EACH SIDE, decrease 1 st. every 12th row 6x, every 8th row 10x (10x) [7x], BUT AT THE SAME TIME, after Row 190 ON EACH SIDE, leave 9 sts. in work then remove the next 29 sts. onto a stitch holder. Hang the pocket linings onto these empty needles and continue as before.
After Row 290, hang the center st. onto adjacent needle and put the needles on the left into holding position. Complete the right side first.
*ON NECK SIDE, for all sizes, decrease 1 st. every 4th row 26x and AT THE SAME TIME, after Row 316, ON SIDE EDGE, increase 1 st. every 8th row 8x.
After Row 384 SHAPE SHOULDER same as the back.
Bring the needles on the left into working position, knit 1 row to the left side, turn the Row Counter back to 290 and complete the left half. Follow the instructions from

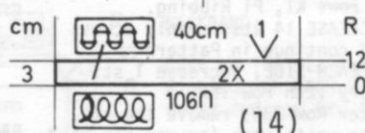

ARM BANDS: Make 2.

Cast on 106 sts. with color 1 and work in Ribbing with color stripes same as the neckband. After Row 12, bind off.

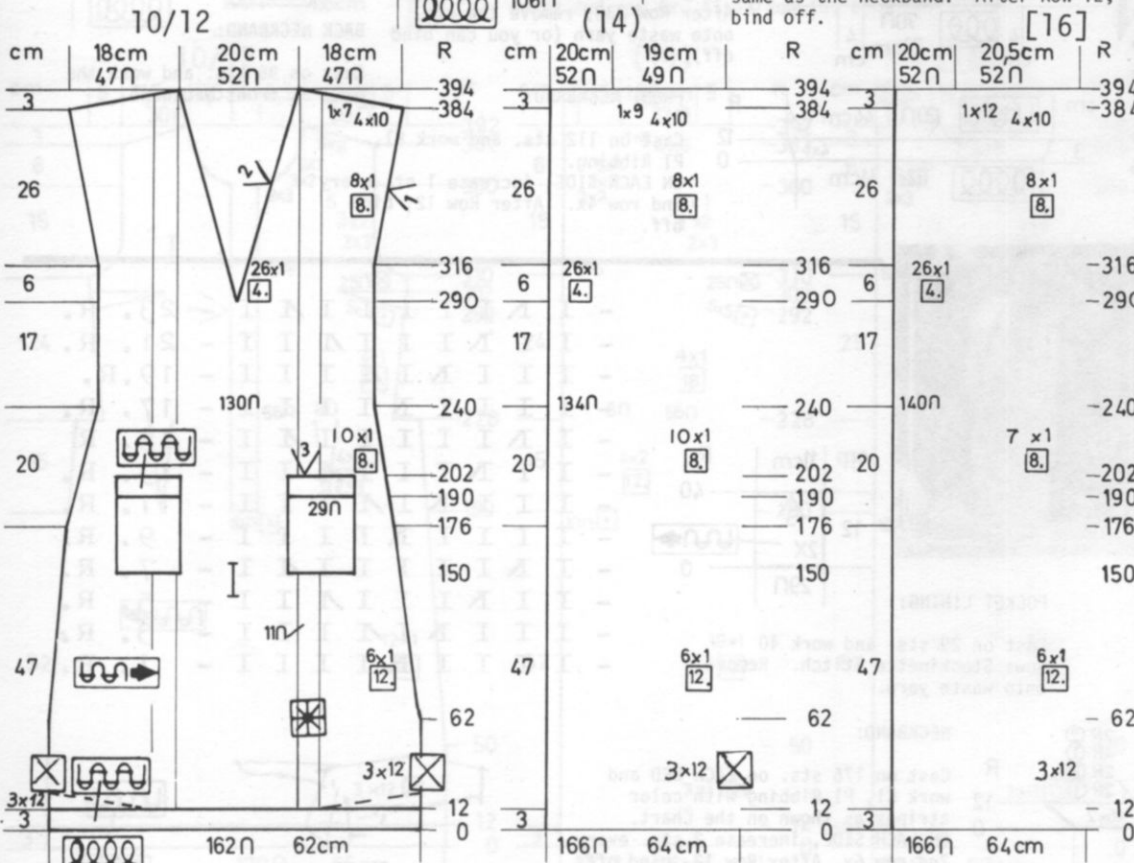

DK 751

WOMAN'S VEST & SKIRT

SIZES: Small (Medium) [Large]
 YARN: Vienna for Knitting, Euro Sport for Weaving.

GRAMS:

color 1	600	600	650
color 2	50	50	50
color 3	50	50	50
color 4	50	50	50
color 5	50	50	50

TENSION: 6 to 8
 GAUGE: 11 sts. 17 1/2 rows = 5 cm (2")

A combination of Stockinette stitch and Weaving. 830 machine owners, use Card No. 1 of your original set and leave the Card on STOP for all Weaving. The Tie is Stockinette stitch with Fairisle Design. Punch your own Card for the isolated Letter. Bands are Ribbed. The Vest is knitted sideways on the machine. Be sure to make a sample swatch and practice the weaving before making skirt and Vest.

FINISHING: See General Instructions. Sew on Bands. Make pleats in skirt then press to your own waist measurement before sewing on the waistband.

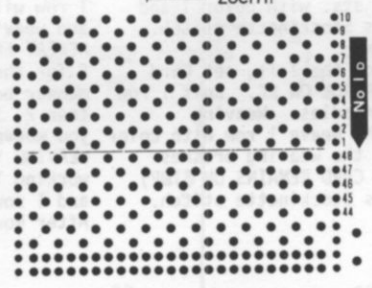
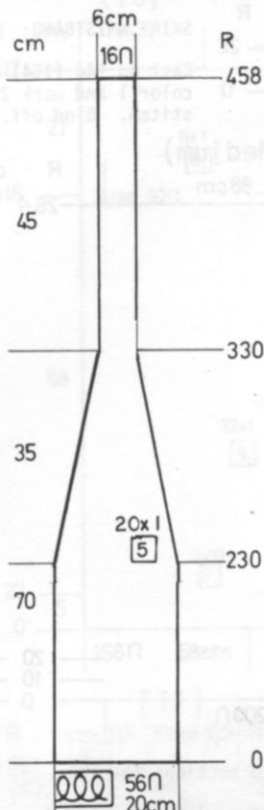

TIE:

Cast on 56 sts. with color 1 and work 40 rows Stockinette stitch then work the isolated Norwegian Design. Continue in Stockinette stitch with color 1 to row 230. ON EACH SIDE, decrease 1 st. every 5th row 20x. Knit to Row 458 then bind off. Face the tie with light weight press on interfacing.

VEST FRONT BAND:

Cast on 15 sts. with color 1 and work 234 rows K1, P1 Ribbing. Bind off.

LOWER FRONT BANDS: Make 2.

Cast on 48 sts. with color 1 and work 20 Rows K1, P1 Ribbing. Bind off.

VEST:

PATTERN STITCH for Vest.
 Row 1 - Weave with color 1
 Row 2 - Knit with color 1
 Row 3 - Weave with color 3
 Row 4 - Knit with color 1
 Row 5 - Weave with color 4
 Row 6 - Knit with color 1
 Go backwards with the weaving colors, each time knitting 1 row between with color 1. There will be always be 2 weaving rows with color 4 and color 1 in order to be able to pick up the yarn on the correct side.

Cast on 126 (132) [138] sts. with color 1. Knit 1 row to the left side. Set Punch Card on Stop and set pattern from left to right. Begin the weaving Pattern. Knit in Pattern to Row 78 (84) [88]. With a separate yarn, bind off 52 (55) [58] sts. on the left side

then immediately cast on the same number of sts. Knit in Pattern to Row 244 (260) [274] then bind off and cast on the same as you did before. Knit in Pattern to Row 322 (344) [362]. Bind off.

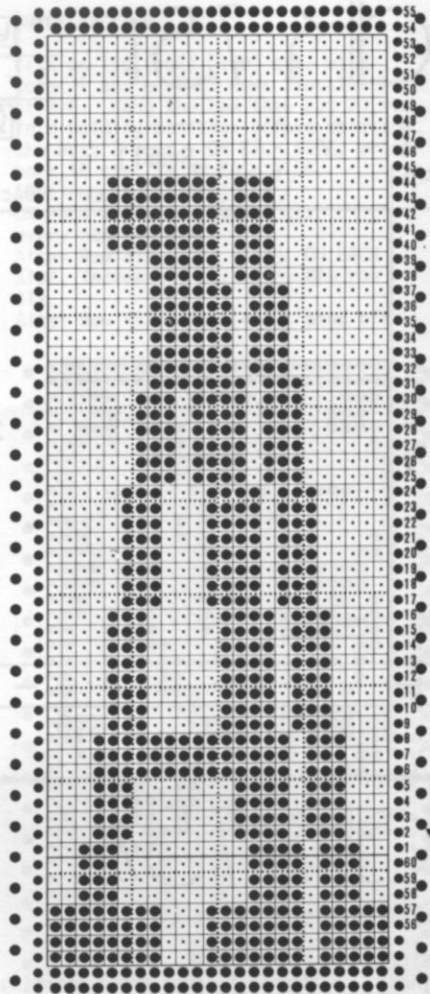

VEST ARMBANDS: Make 2.

Cast on 120 sts. and work 30 rows K1, P1 Ribbing. Bind off.

BACK VEST BAND:

Cast on 94 sts. with color 1 and work 20 rows K1, P1 Ribbing. Bind off.

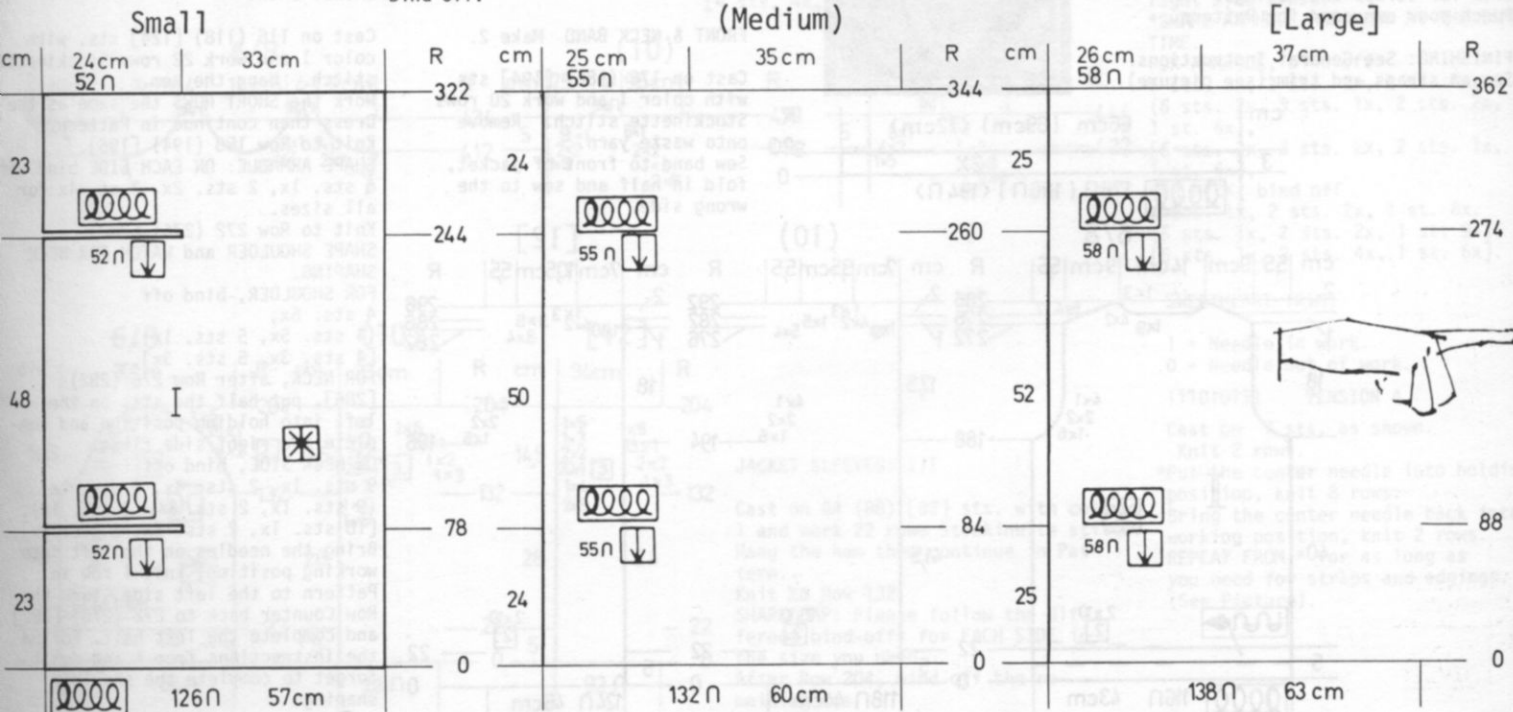

dk 751

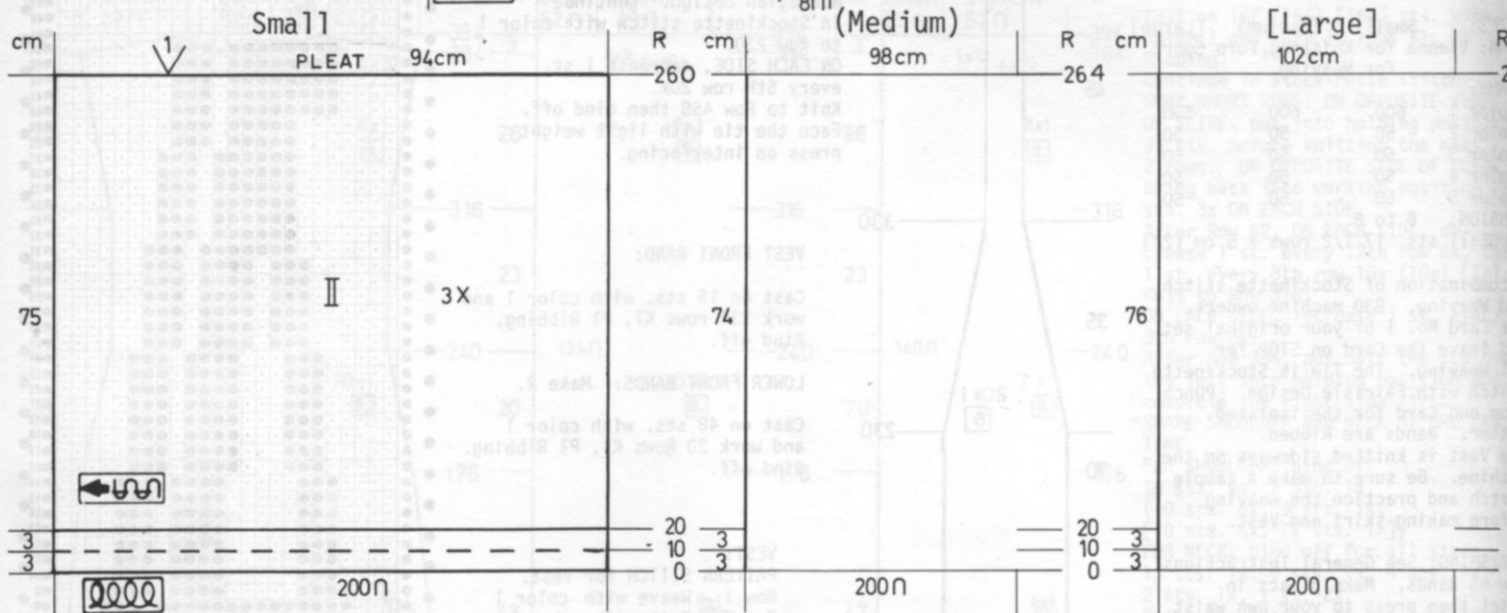
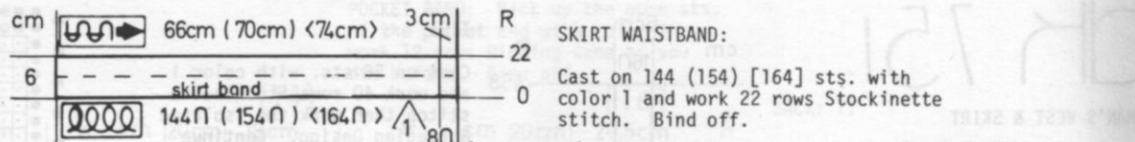

SKIRT: Make 3 sections the same.

Cast on 200 sts. with color 1 and work 20 rows Stockinette stitch. Hang the hem. With Slide on the left, set Card on STOP, CONTROL ON KC. Knit 1 row to set the needles. Weaving brushes DOWN, weave 1 row with color 2. Release the weaving brushes and KC. (THE CARD REMAINS ON STOP). *Knit 11 rows Stockinette stitch.

Set KC, knit 1 row to set the needles. Weaving brushes DOWN, weave 1 row with color 3. Release KC and weaving brushes. REPEAT FROM * using color 4, then 5 for the weaving. Continue in this manner beginning again with color 1 then 2, 3, 4, 5 for weaving. Each time you weave a row, you must CUT THE WEAVING YARN. You will actually be working 12 rows stockinette stitch and 1 row of weaving throughout. After Row 260 (264) [276], bind off.

dk 752

WOMAN'S DRESS & JACKET

SIZES: 6/8 (10) [12]
YARN: Vienna & large spool matching Thread.

GRAMS:
color 1 800 800 850
color 2 - matching thread (not included in Kit).

TENSION: 5 to 7
GAUGE: 13 1/2 sts. 23 1/2 rows = 5 cm

Norwegian Technique (Studio machine owners can use Punch Lace) Sweetheart trim for straps and edgings. Punch your own card for Pattern.

FINISHING: See General Instructions. Sew on straps and trim (see picture).

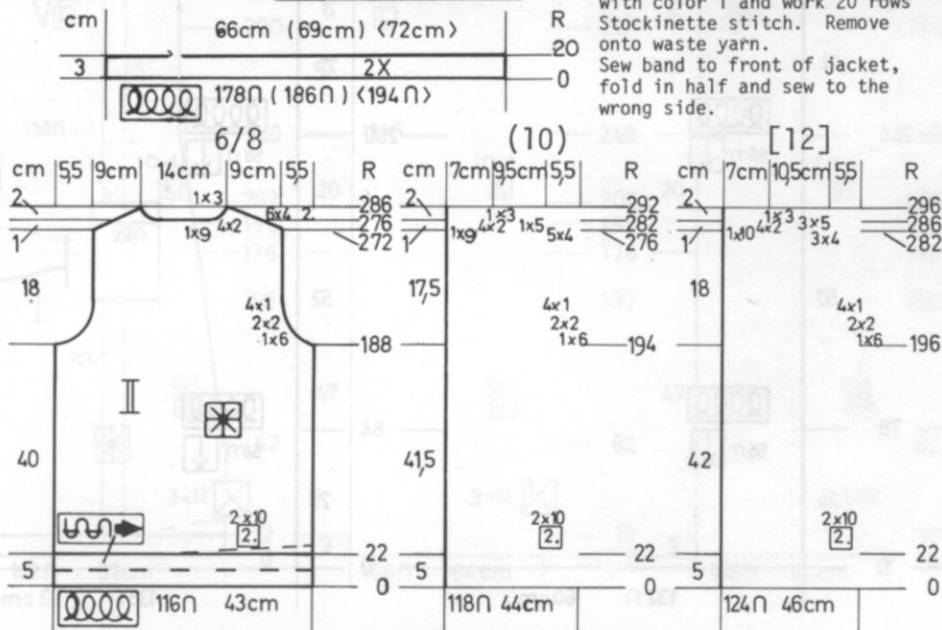

FRONT & NECK BAND Make 2.

Cast on 178 (186) [194] sts. with color 1 and work 20 rows Stockinette stitch. Remove onto waste yarn. Sew band to front of jacket, fold in half and sew to the wrong side.

JACKET BACK:

Cast on 116 (118) [124] sts. with color 1 and work 22 rows Stockinette stitch. Hang the hem. Work the SHORT ROWS the same as the Dress then continue in Pattern. Knit to Row 188 (194) [196]. SHAPE ARMHOLE: ON EACH SIDE bind off 6 sts. 1x, 2 sts. 2x, 1 st. 4x for all sizes. Knit to Row 272 (276) [282]. SHAPE SHOULDER and WATCH FOR NECK SHAPING. FOR SHOULDER, bind off 4 sts. 6x, (4 sts. 5x, 5 sts. 1x), [4 sts. 3x, 5 sts. 3x], FOR NECK, after Row 276 (282) [286], put half the sts. on the left into holding position and complete the right side first. *ON NECK SIDE, bind off 9 sts. 1x, 2 sts. 4x, 3 sts. 1x. (9 sts. 1x, 2 sts. 4x, 3 sts. 1x). [10 sts. 1x, 2 sts. 4x, 3 sts. 1x] Bring the needles on the left into working position, knit 1 row in Pattern to the left side, turn the Row Counter back to 272 (276) [282] and complete the left half. Follow the instructions from * and don't forget to complete the shoulder shaping.

6/8

(10)

[12]

DRESS BACK: V

Cast on 150 (156) [160] sts. with color 1 and work 22 rows Stockinette stitch. Hang the hem then put 20 sts. into holding position before knitting the next 2 rows. ON EACH SIDE, bring back 10 sts. 2x ON EACH SIDE. Continue in Pattern. ON EACH SIDE, decrease 1 st. every 9th row 32x. After Row 318 (320) [322], ON EACH SIDE, increase 1 st. every 8th row 11x. After Row 412 (418) [422], bind off.

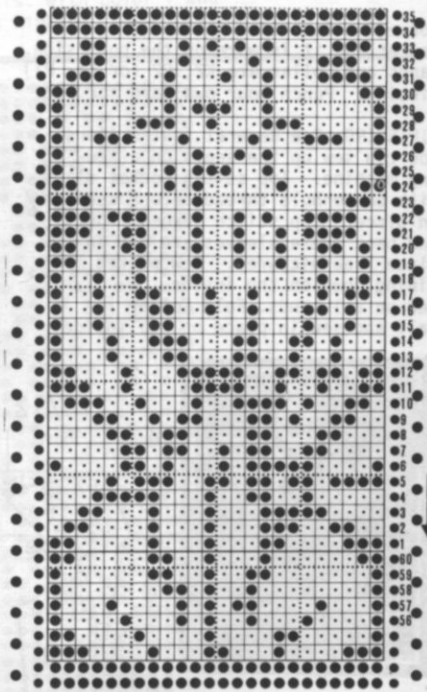

DRESS FRONT: IV

Work the front the same as the back to Row 412 (418) [422]. Put half the sts. on the left into holding position and complete the right side first. *SHAPE ARMHOLE AND NECK AT THE SAME TIME. FOR ARMHOLE, bind off 6 sts. 2x, 2 sts. 2x, 1 st. 7x, (6 sts. 2x, 3 sts. 1x, 2 sts. 2x, 1 st. 6x), [6 sts. 2x, 3 sts. 2x, 2 sts. 1x, 1 st. 6x], FOR NECK, bind off 5 sts. 1x, 2 sts. 2x, 1 st. 8x. (5 sts. 1x, 2 sts. 2x, 1 st. 9x). [5 sts. 1x, 2 sts. 4x, 1 st. 6x].

SWEETHEART TRIM:

1 = Needle in work.
0 = Needle out of work.

111010111 TENSION 4

Cast on 7 sts. as shown.
Knit 2 rows.

*Put the center needle into holding position, knit 8 rows. Bring the center needle back into working position, knit 2 rows. REPEAT FROM * for as long as you need for straps and edgings. (See Picture).

JACKET FRONT: I Make 1, reverse 1.

Cast on 55 (56) [58] sts. with color 1 and work 22 rows Stockinette stitch. Hang the hem. Continue in Pattern. Knit to Row 190 (192) [194]. SHAPE ARMHOLE AND WATCH FOR NECK SHAPING. FOR ARMHOLE, bind off 8 sts. 1x, 3 sts. 1x, 2 sts. 1x, 1 st. 4x. (Same as first size). [8 sts. 1x, 3 sts. 2x, 2 sts. 1x, 1 st. 2x]. AT THE SAME TIME, after Row 200 (202) [204], SHAPE NECK ON OPPOSITE SIDE OF SLIDE. Decrease 1 st. every 6th row 14x for all sizes. After Row 278 (280) [282], SHAPE SHOULDER: Bind off 4 sts. 6x. (4 sts. 5x, 5 sts. 1x). [4 sts. 4x, 5 sts. 2x].

JACKET SLEEVES: III

Cast on 84 (88) [92] sts. with color 1 and work 22 rows Stockinette stitch. Hang the hem then continue in Pattern. Knit to Row 132. SHAPE CAP: Please follow the different bind-offs for EACH SIDE in the size you need. After Row 204, bind off the remaining sts.

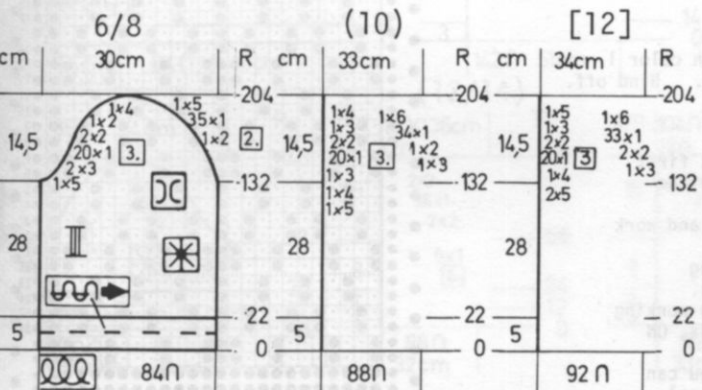
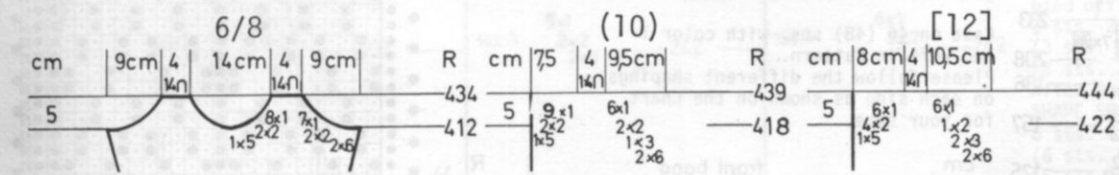
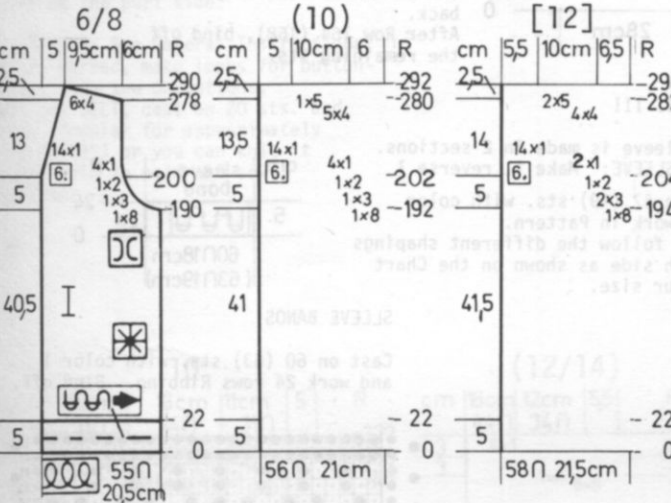
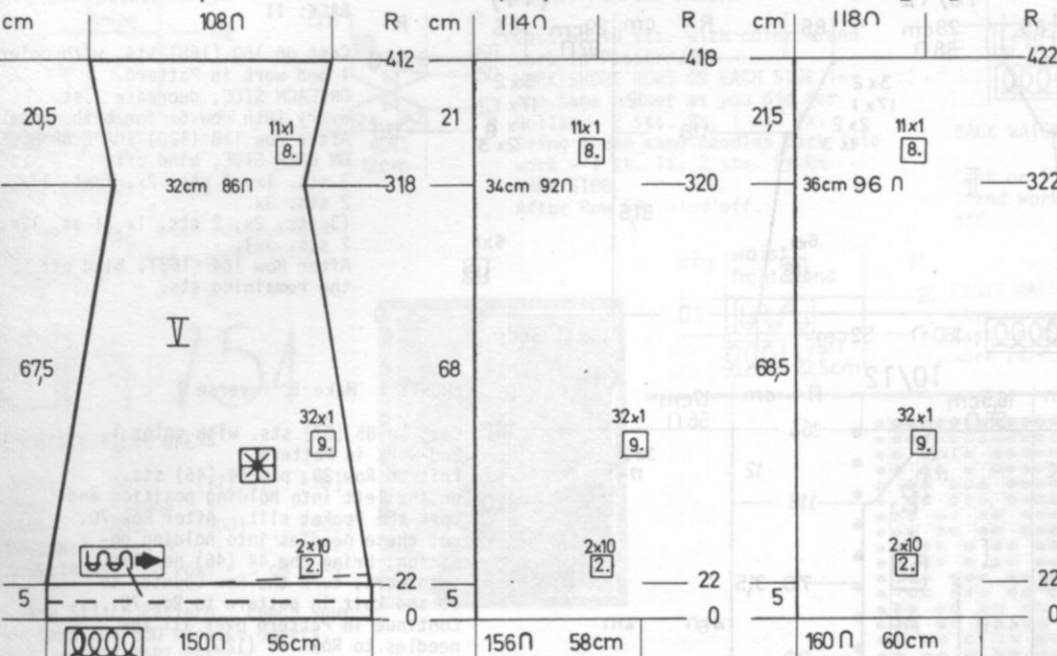

dk 753

WOMAN'S JACKET

SIZES: 10/12 (14)
 YARN: - Color 1 = Vienna
 Color 2 = Euro Sport

GRAMS:
 color 1 300 350
 color 2 600 650
 TENSION: 6 to 8
 GAUGE: 15 sts. 19 rows = 5 cm (2")

Norwegian technique is used for this Jacket and it is worn on the purl side. Bands and Collar are K2, P2 (or K1, P1) Ribbing. Punch your own Card for Pat.

FINISHING: See General Instructions. You can sew up the seams on a sewing machine. Top stitch pocket flaps with buttonhole thread before sewing in place. Top stitch across fronts and back where sleeves are set in place (see picture). Sew pocket lining down on the inside. Sew on all bands. Fold Collar in half and sew in place on the inside.

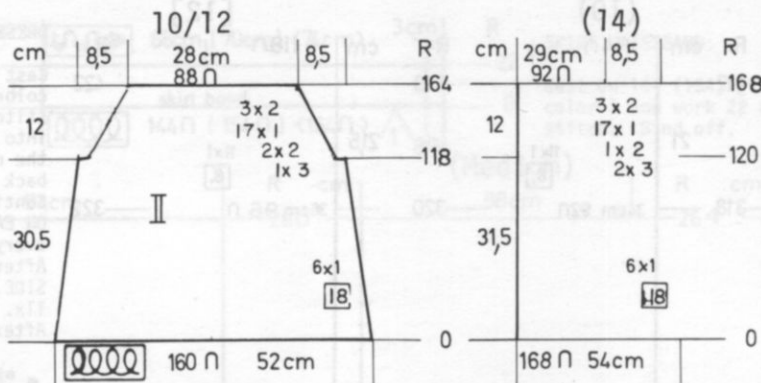

BACK: II

Cast on 160 (168) sts. with color 1 and work in Pattern. ON EACH SIDE, decrease 1 st. every 18th row 6x for both sizes. After Row 118 (120) SHAPE ARMHOLE ON EACH SIDE, bind off 3 sts. 1x, 2 sts. 2x, 1 st. 17x, 2 sts. 3x. (3 sts. 2x, 2 sts. 1x, 1 st. 17x, 2 sts. 3x). After Row 164 (168), bind off the remaining sts.

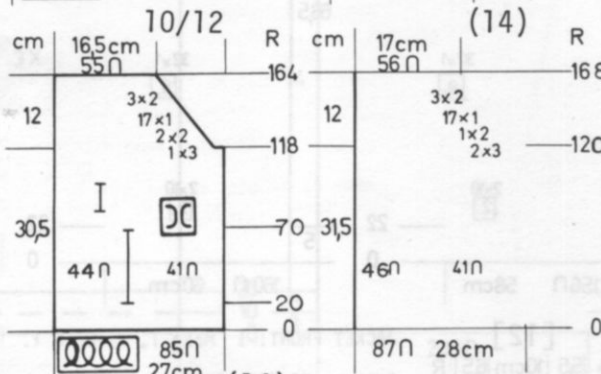

FRONT: I Make 1, reverse 1

Cast on 85 (87) sts. with color 1 and work in Pattern. Knit to Row 20, put 44 (46) sts. on the left into holding position and work the Pocket slit. After Row 70, put these needles into holding position, bring the 44 (46) needles into work, turn the Row Counter to 20 and knit in pattern to Row 70. Continue in Pattern over all the needles to Row 118 (120). SHAPE ARMHOLE same as you did the back. After Row 164 (168), bind off the remaining sts.

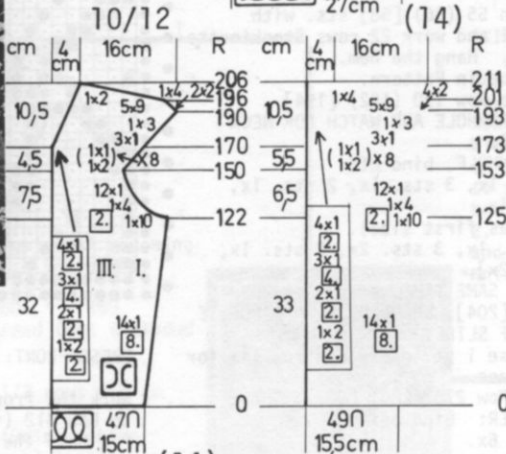

SLEEVES: III

Each sleeve is made in 2 sections. FRONT SLEEVE: Make 1, reverse 1
 Cast on 47 (49) sts. with color 1 and work in Pattern. Please follow the different shapings on each side as shown on the Chart for your size.

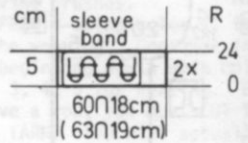

SLEEVE BANDS:

Cast on 60 (63) sts. with color 1 and work 24 rows Ribbing. Bind off.

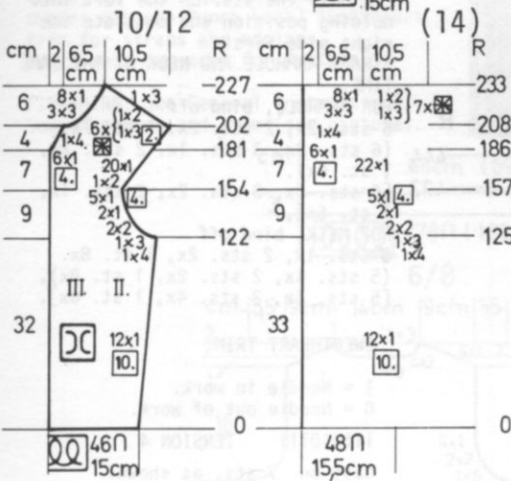

BACK SLEEVE: Make 1, reverse 1.

Cast on 46 (48) sts. with color 1 and work in Pattern. Please follow the different shapings on each side as shown on the Chart for your size.

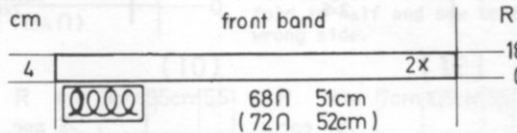

FRONT BAND Make 2.

Cast on 68 (72) sts. with color 1 and work 18 rows Ribbing. Bind off.

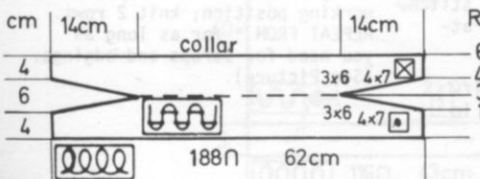

COLLAR: Work the front bands first and sew in place then pick up the sts. for the Collar. Pick up 188 sts. with color 1 and work in Ribbing. ON EACH SIDE, put into holding position, 7 sts. 4x, 6 sts. 3x. After Row 30, bring back into working position, 3 sts. 6x, 7 sts. 4x, ON EACH SIDE. After Row 60, bind off (or you can remove the sts. onto waste yarn).

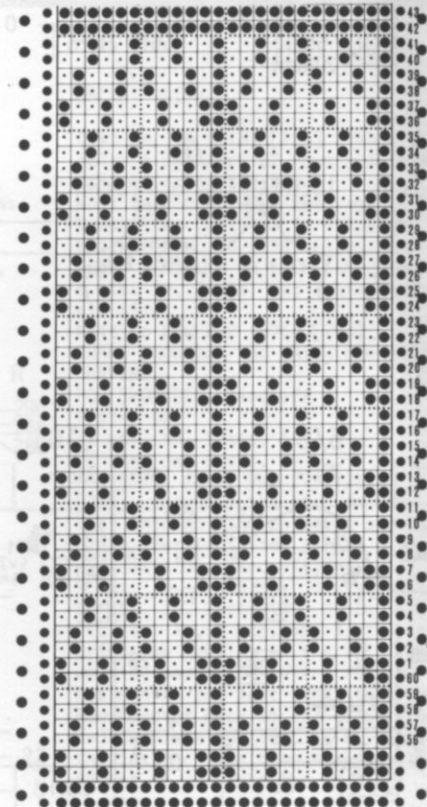

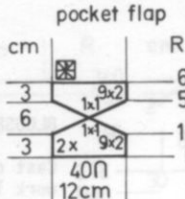
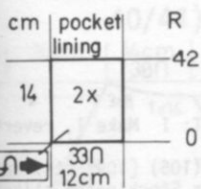

POCKET FLAPS: Make 2.

Cast on 40 sts. with color 1 and work in Pattern.
 WORK SHORT ROWS ON EACH SIDE in the same manner as you did for Collar - 2 sts. 9x, 1 st. 1x. Bring these same needles back into work - 1 st. 1x, 2 sts. 9x ON EACH SIDE.
 After Row 60, bind off.

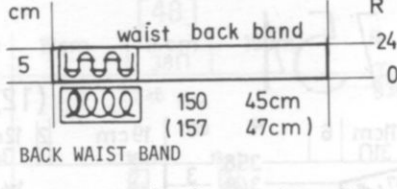

Cast on 150 (157) sts. with color 1 and work 24 rows Ribbing. Bind off.

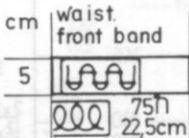

FRONT WAIST BAND Make 2.
 Cast on 75 sts. with color 1 and work 24 rows Ribbing. Bind off.

DK 754

WOMAN'S 2-PIECE DRESS

SIZES: 10 (12/14) [16]
 YARN: Vienna
 GRAMS: 850 (900) [900]
 TENSION: 6 to 8
 GAUGE: 14 sts. 26 rows = 5 cm (2")



A Slip Stitch Pattern. Punch your own Card and 830 machine owners, push in BOTH PART Buttons. Worn on the purl side.

FINISHING: See General Instructions. Where marked, make loops for buttonholes then sew on buttons. For the BELT, cast on 20 sts. and knit circular for approximately 150 cm (59") or you can knit it flat, fold in half and sew together.

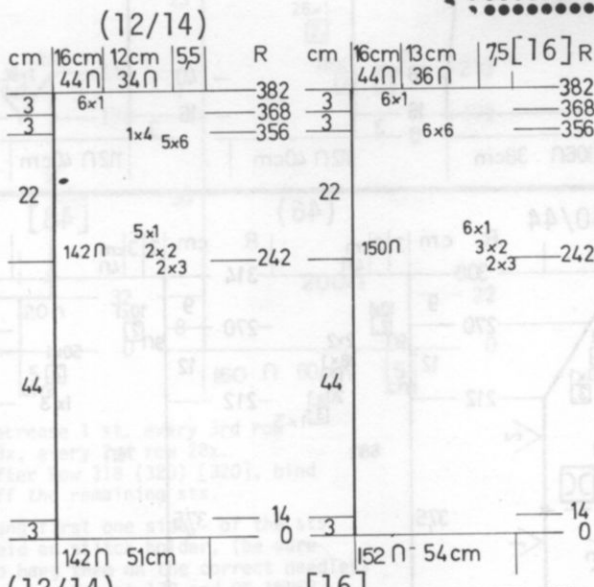
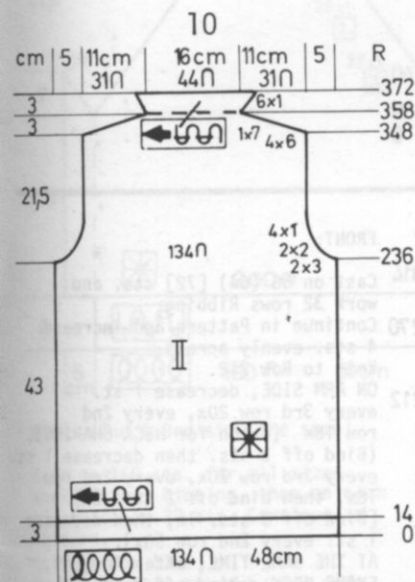
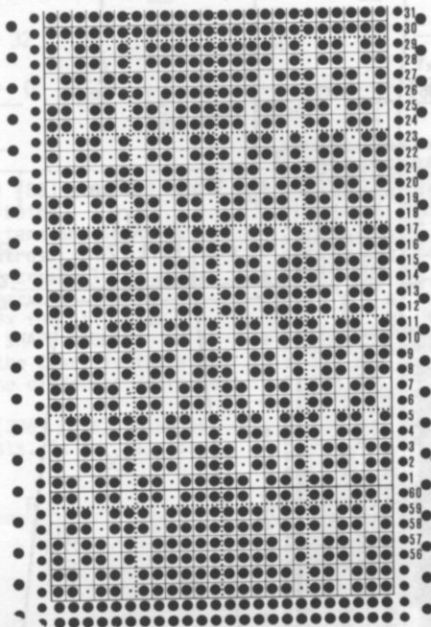

BLOUSE BACK: II

Cast on 134 (142) [152] sts. and work 14 rows Stockinette stitch. Continue in Pattern.
 Knit to Row 236 (242) [242].
 SHAPE ARMHOLE: ON EACH SIDE, bind off
 3 sts. 2x, 2 sts. 2x, 1 st. 4x.
 (3 sts. 2x, 2 sts. 2x, 1 st. 5x).
 [3 sts. 2x, 2 sts. 3x, 1 st. 6x].
 After Row 348 (356) [356],
 SHAPE SHOULDER: ON EACH SIDE, bind off
 6 sts. 4x, 7 sts. 1x.
 (6 sts. 5x, 4 sts. 1x).
 [6 sts. 6x].
 After Row 358 (368) [368], continue in Stockinette stitch for back neck facing.
 ON EACH SIDE, increase 1 st. every 2nd row 6x.
 After Row 372 (382) [382], bind off the remaining sts.

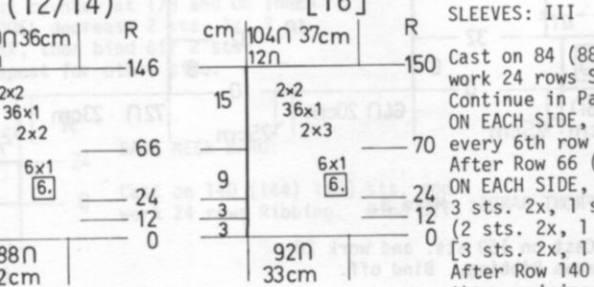
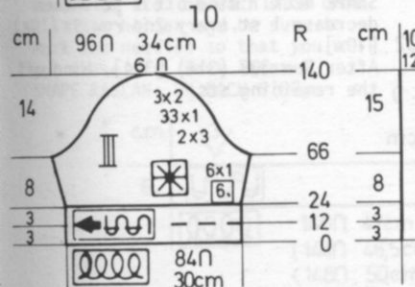

SLEEVES: III

Cast on 84 (88) [92] sts. and work 24 rows Stockinette stitch. Continue in Pattern.
 ON EACH SIDE, increase 1 st. every 6th row 6x.
 After Row 66 (66) [70], SHAPE CAP:
 ON EACH SIDE, bind off
 3 sts. 2x, 1 st. 33x, 2 sts. 3x.
 (2 sts. 2x, 1 st. 36x, 2 sts. 2x).
 [3 sts. 2x, 1 st. 36x, 2 sts. 2x].
 After Row 140 (146) [150], bind off the remaining sts.



dk 754

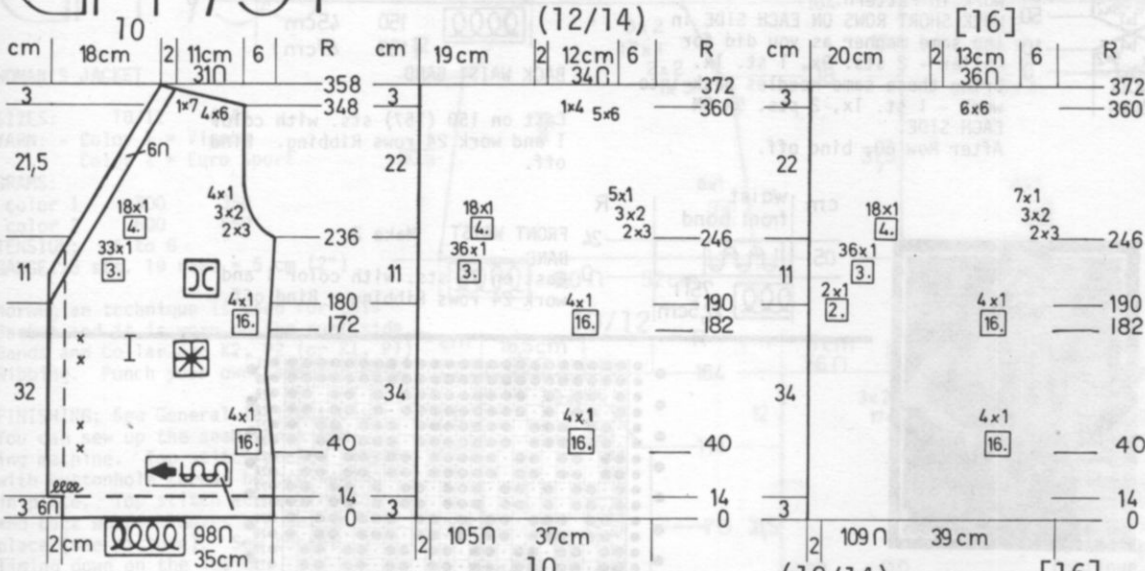

BLOUSE FRONT: I Make 1, reverse 1
 Cast on 98 (105) [109] sts. and work 14 rows Stockinette stitch. Continue in Pattern. After Row 40, ON SIDE EDGE, decrease 1 st. every 16th row 4x.
 After Row 172 (182) [182], ON SIDE EDGE, increase 1 st. every 16th row 4x, AND AT THE SAME TIME, after Row 180 (190) [190], ON FRONT EDGE, hang the 7th st. onto the 8th st. and move the sts. in to fill the empty needle. REPEAT the front decreases every 3rd row 32x more then every 4th row 18x.
 (every 3rd row 35x more then every 4th row 18x).
 [every 2nd row 1x more then every 3rd row 36x, every 4th row 18x].
 After Row 348 (360) [360], SHAPE SHOULDER same as the back.

np 755



MAN'S CARDIGAN

SIZES: 40/44 (46) [48]
YARN: Amore
GRAMS: 700 700 750
TENSION: 10
GAUGE: 14 sts. 24 rows = 5 cm (2")

A Slip stitch Pattern. Punch your own card. 830 machine owners push in BOTH PART BUTTONS. Worn on the purl side.
 Bands are Ribbed.

FINISHING: See General instructions. Leave seam open on sides for pocket. Sew in pocket lining. Sew pocket band to front of pocket opening. Sew on bands, turn to the inside and sew in place. Finish Buttonholes and Sew on Buttons.

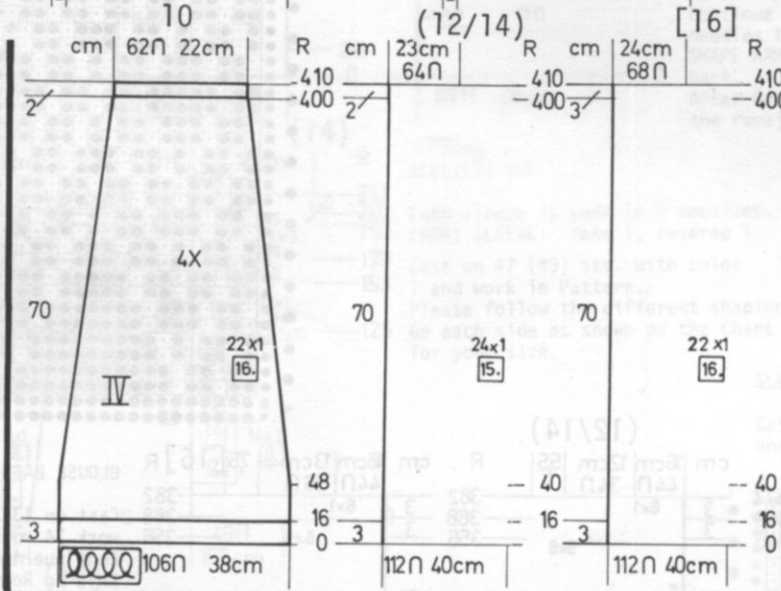

SKIRT: IV Make 4 sections the same
 Cast on 106 (112) [112] sts. and work 16 rows Stockinette stitch. Continue in Pattern ON EACH SIDE, after Row 48 (40) [40], decrease 1 st. every 16th row 22x (every 15th row 24x).
 [every 16th row 22x].
 After Row 410, bind off.

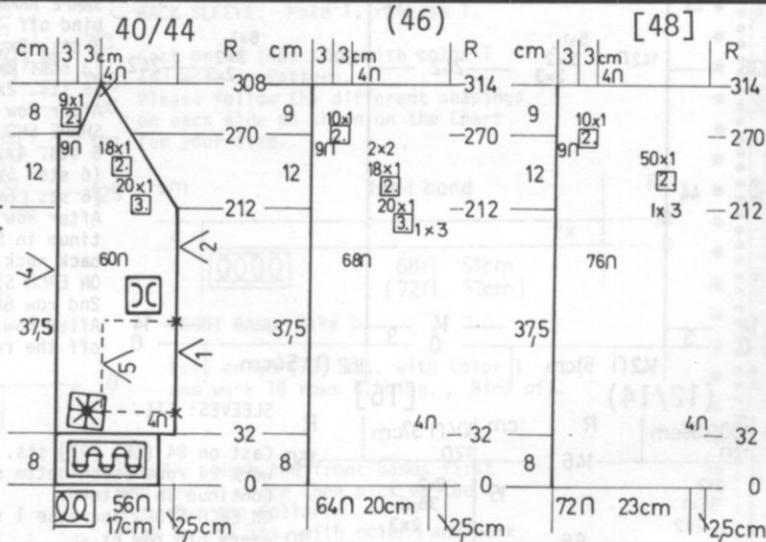

FRONT:
 Cast on 56 (64) [72] sts. and work 32 rows Ribbing. Continue in Pattern and increase 4 sts. evenly across. Knit to Row 212. ON ARM SIDE, decrease 1 st. every 3rd row 20x, every 2nd row 18x (Watch for NECK SHAPING). (Bind off 3 sts. then decrease 1 st. every 3rd row 20x, every 2nd row 18x, then bind off 2 sts. 2x). [Bind off 3 sts. 1x, then decrease 1 st. every 2nd row 50x]. AT THE SAME TIME, after Row 269, SHAPE NECK: Bind off 9 sts. then decrease 1 st. every 2nd row 9x [10x] [10x]. After Row 308 (314) [314], bind off the remaining sts.

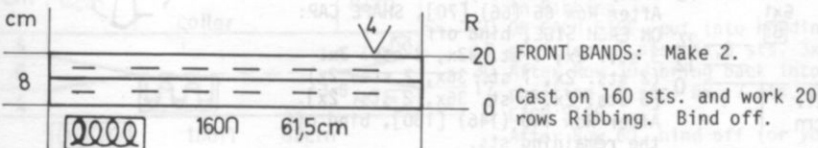

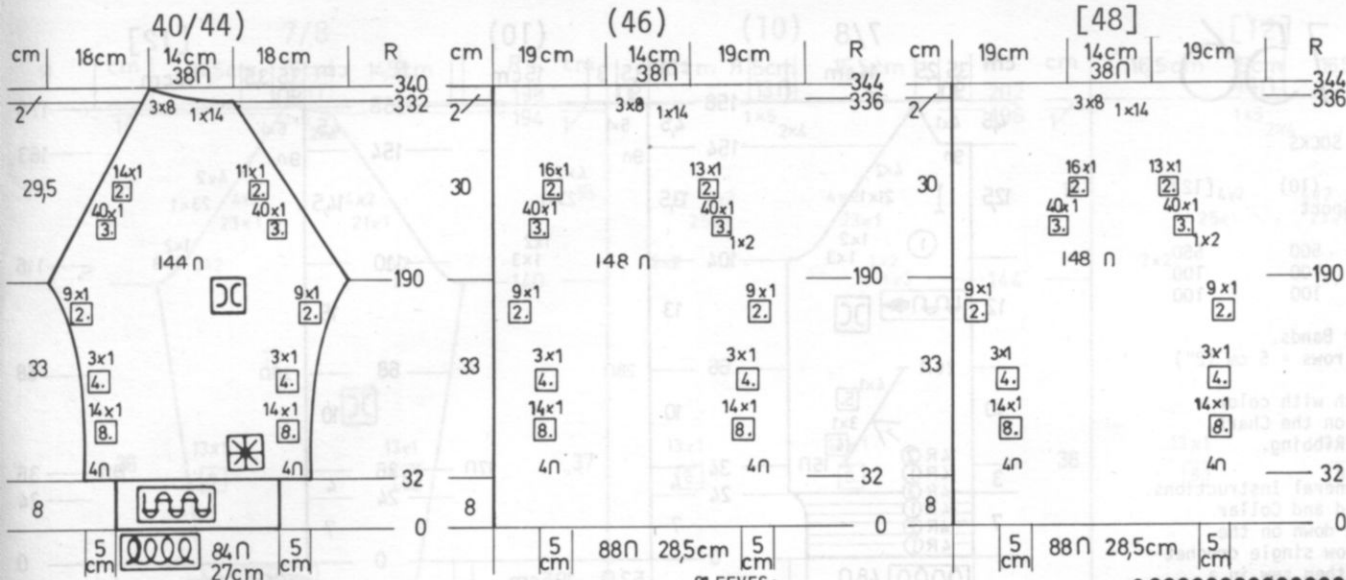

SLEEVES:

Cast on 84 (88) [88] sts. and work 32 rows Ribbing. Continue in Pattern and INCREASE 8 sts. evenly across. ON EACH SIDE, increase 1 st. every 8th row 14x, every 4th row 3x, every 2nd row 9x for all sizes. After Row 190, SHAPE RAGLAN: Please follow the Chart in the size you need for the different decreases on each side. After Row 332, (336) [336], bind off 14 sts. 1x, 8 sts. 3x for all sizes.

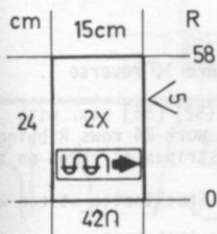
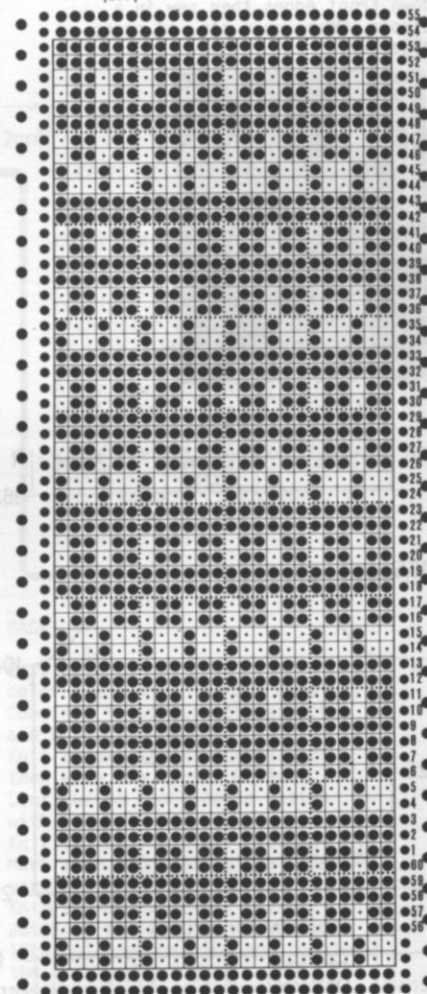

POCKET LINING: Make 2.

Cast on 42 sts. and work 58 rows Stockinette stitch. Bind off.

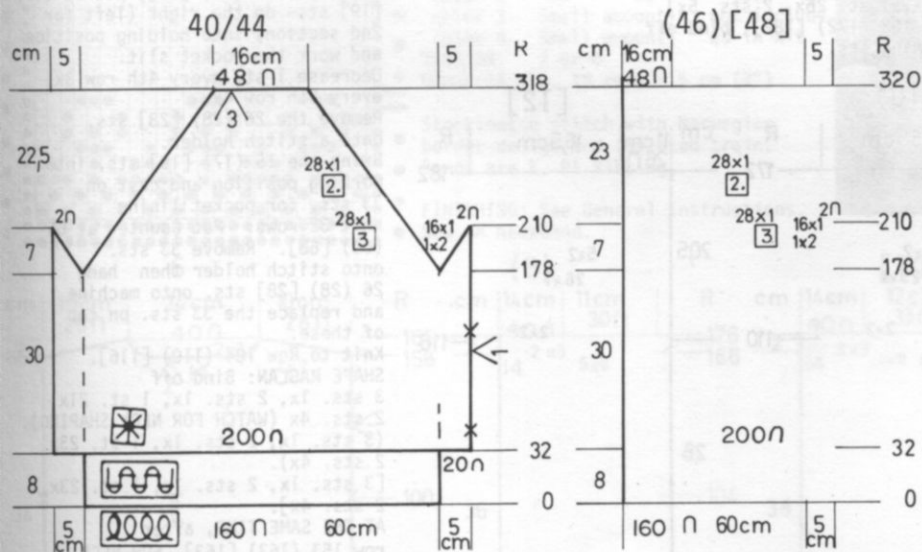

BACK: (2nd & 3rd size the same).

Cast on 160 sts. for all sizes. Work 32 rows Ribbing, then on each side cast on 20 sts. Continue in Pattern. Knit to Row 178. Remove 20 sts. on each side onto a stitch holder and be sure to mark the needles so that you will put these sts. back later. SHAPE RAGLAN: ON EACH SIDE,

decrease 1 st. every 3rd row 28x, every 2nd row 28x. After Row 318 (320) [320], bind off the remaining sts. Hang first one side, of the sts. held on stitch holder, (be sure to hang them on the correct needles) put counter at 178 and ON INNER EDGE, decrease 2 sts. 1x, 1 st. 16x, then bind off 2 sts. Repeat for other side.

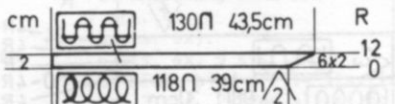

SIDE & POCKET BANDS: Make 2.

Cast on 118 sts. and work in Ribbing. ON THE RIGHT (left for 2nd band) cast on 2 sts. 6x. After Row 12, bind off.

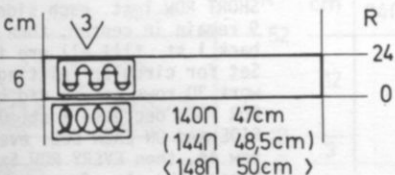

BACK NECK BAND: Cast on 140 (144) [148] sts. and work 24 rows Ribbing. Bind off

KK 756

CHILD'S JACKET & SOCKS

SIZES: 7/8 (10) [12]

YARN: Euro Sport

GRAMS:

color 1	500	500	550
color 2	100	100	100
color 3	100	100	100

TENSION: 10

8 for Bands.

GAUGE: 12 sts. 16 rows = 5 cm (2")

Stockinette stitch with color stripes as shown on the Chart. Bands are K1, P1 Ribbing.

FINISHING: See General Instructions.

Sew on Pocket Band and Collar
Sew pocket lining down on the inside. Work 1 row single crochet down front edges then sew in a zipper. Weave open sts. of socks together.

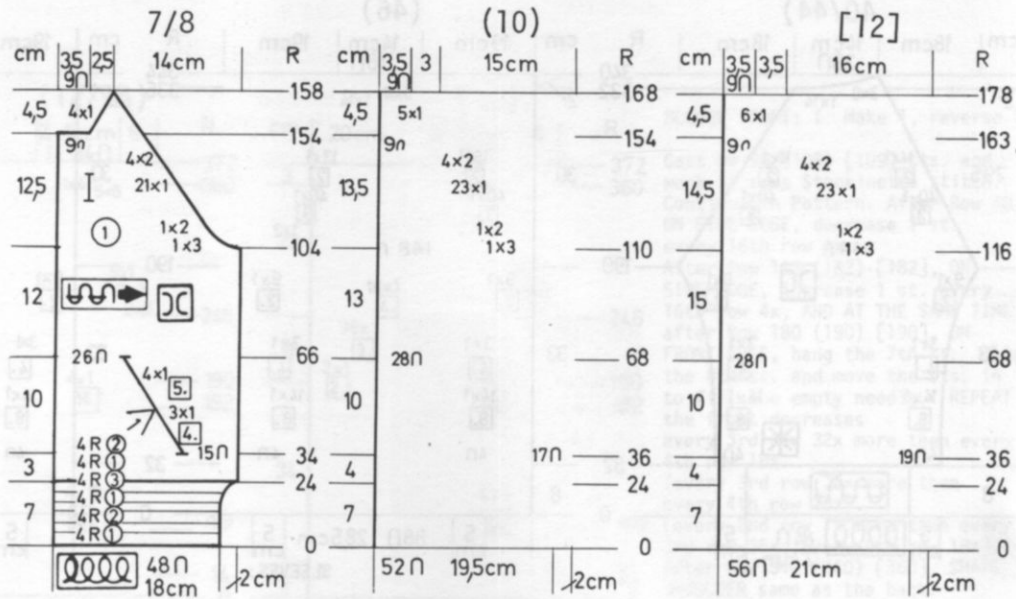

BACK: II

Cast on 94 (100) [106] sts. with color 1 and work 24 rows Ribbing, with color stripes same as the Front. Continue in Stockinette stitch with color 1.

Knit to Row 104 (110) [116].

SHAPE RAGLAN: ON EACH SIDE, bind off

2 sts. 2x, 1 st. 23x, 2 sts. 4x.

(2 sts. 2x, 1 st. 25x, 2 sts. 4x).

[2 sts. 2x, 1 st. 26x, 2 sts. 5x].

After Row 162 (172) [182], bind off the remaining sts.

FRONT: I Make 1, reverse 1.

Cast on 48 (52) [56] sts. with color 1 and work 24 rows Ribbing with color stripes as shown on the Chart. Continue in Stockinette stitch with color 1.

After Row 34 (36) [36], put 15 (17) [19] sts- on the right (left for 2nd section) into holding position and work the pocket slit. Decrease 1 st. every 4th row 3x, every 5th row 4x.

Remove the 26 (28) [28] sts. onto a stitch holder.

Bring the 15 (17) [19] sts. into working position and cast on 33 sts. for pocket lining.

Knit 32 rows. Put Counter at 66 (68) [68]. Remove 33 sts. onto stitch holder then hang 26 (28) [28] sts. onto machine and replace the 33 sts. on top of these.

Knit to Row 104 (110) [116].

SHAPE RAGLAN: Bind off

3 sts. 1x, 2 sts. 1x, 1 st. 21x,

2 sts. 4x (WATCH FOR NECK SHAPING).

(3 sts. 1x, 2 sts. 1x, 1 st. 23x,

2 sts. 4x).

[3 sts. 1x, 2 sts. 1x, 1 st. 23x,

2 sts. 4x].

AT THE SAME TIME, after

row 153 (163) [163], FOR NECK,

bind off 9 sts. then 1 st. every

2nd row 4x (5x) [6x].

SOCKS:

Cast on 50 sts. with color 1 and

work 24 rows Ribbing with color

stripes as on back and front of

Jacket.

Decrease 1 st. each side.

Set for circular knitting and

work circular for 30 rows.

Work the heel on main bed only.

SHORT ROW 1 st. each side till

9 remain in center, then bring

back 1 st. till all are in work.

Set for circular knitting and

work 30 rows as you did before.

FOR TOE, decrease 1 st. ON EACH

SIDE and ON EACH BED, every 2nd

row 4x, then EVERY ROW 5x.

Remove the sts. from each bed onto

separate strand of waste yarn.

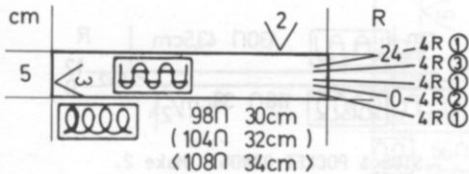
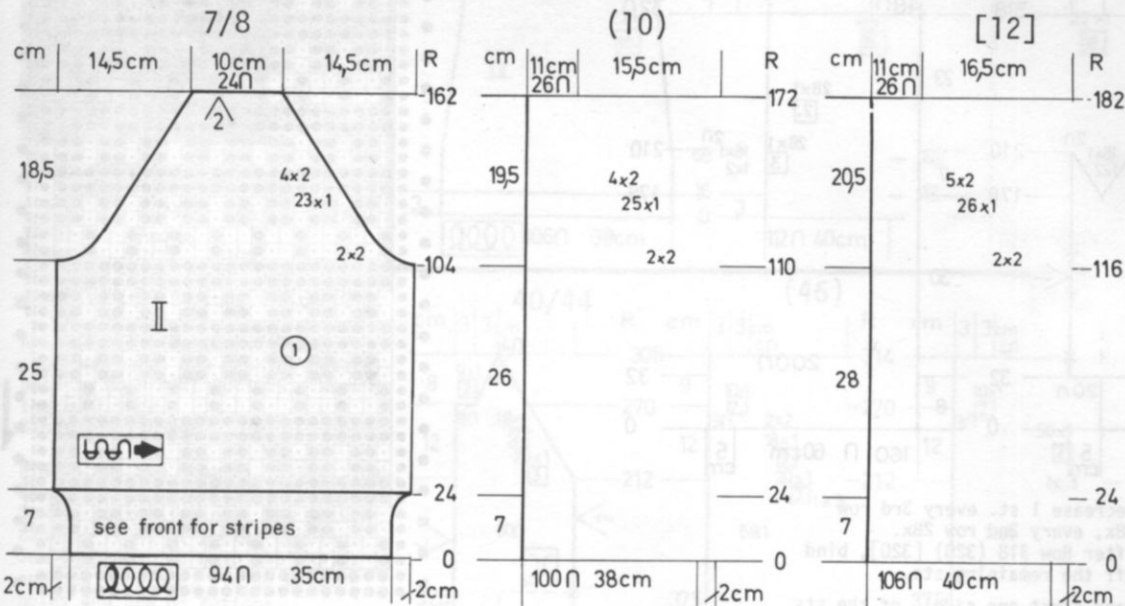

COLLAR:

Cast on 98 (104) [108] sts. with color 1 and work 24 rows Ribbing with color stripes as shown on the Chart. Bind off.

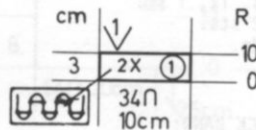

POCKET BAND: Make 2.

Cast on 34 sts. with color 1 and work 10 rows Ribbing. Bind off.

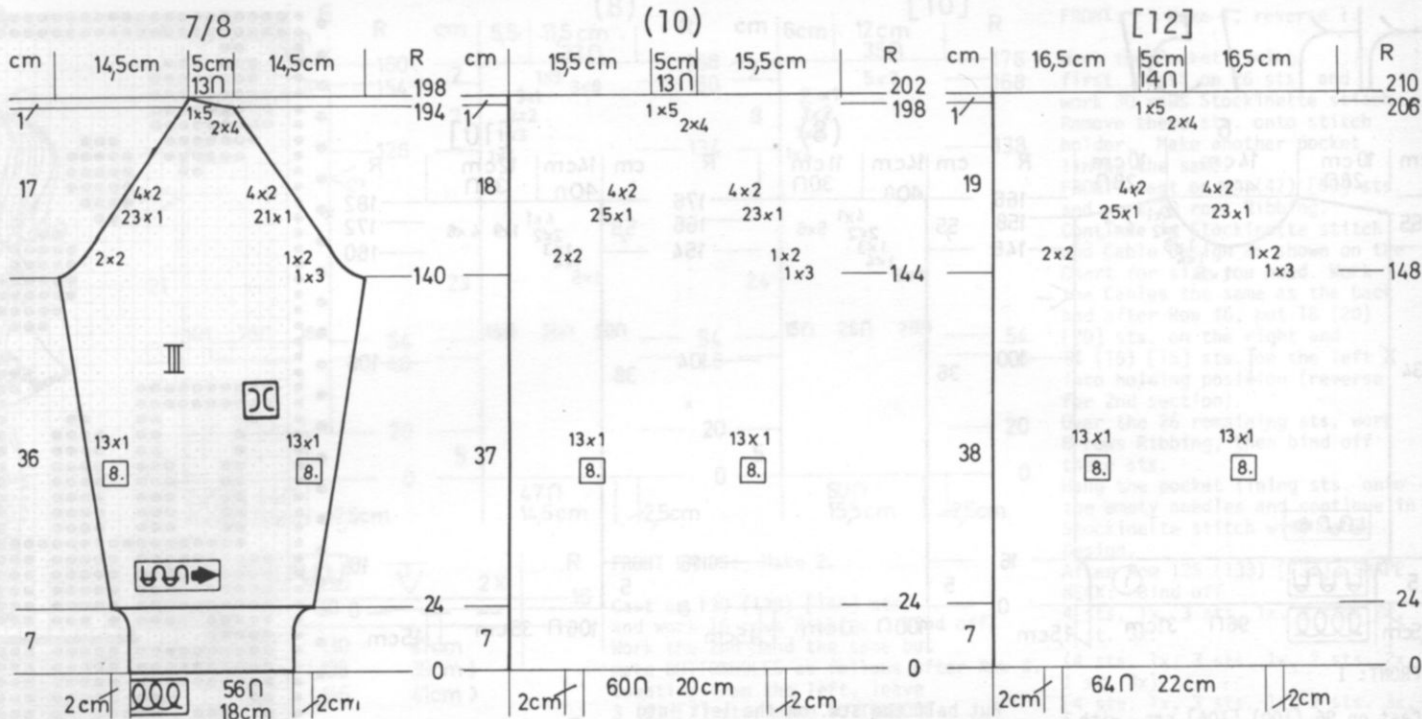

KK 757

CHILD'S PULLOVER

SIZES: 6 (8) [10]
 YARN: Euro Sport
 GRAMS:
 color 1 250 250 300
 color 2 50 50 50
 color 3 Small amount) not included
 color 4 Small amount) ed in Kit
 TENSION: 7 or 8
 GAUGE: 14 sts. 19 rows = 5 cm (2")

Stockinette stitch with Norwegian border design and isolated train. Bands are K. P1 Ribbing.

FINISHING: See General Instructions. Sew on Neckband.



SLEEVES: III Make 1, reverse 1.

Cast on 56 (60) [64] sts. with color 1 and work 24 rows Ribbing with color stripes as on the front and back. Continue in Stockinette stitch with color 1. ON EACH SIDE, increase 1 st. every 8th row 13x for all sizes. After Row 140 (144) [148], SHAPE RAGLAN: Please follow the Chart in the size you need for the different binds off ON EACH SIDE. After Row 194 (198) [206], Bind off 4 sts. 2x, 5 sts. 1x for all sizes.

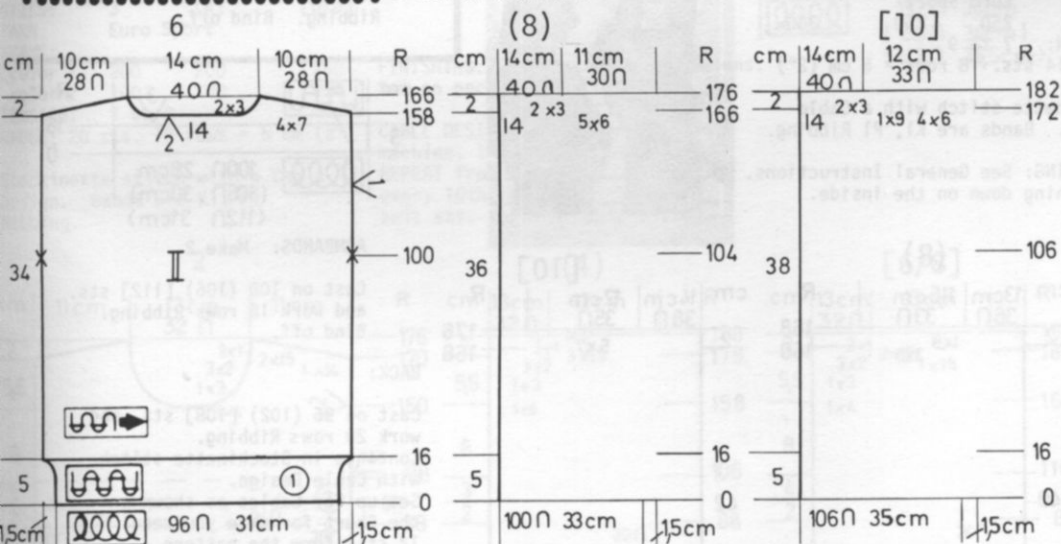

BACK: II

Cast on 96 (100) [106] sts. with color 1 and work 16 rows Ribbing. Continue in Stockinette stitch and Norwegian Design. Knit 2 rows Stockinette stitch then work the Border Design. Continue in Stockinette stitch with color 1. Knit to Row 100 (104) [106]. Mark each side with bit of waste yarn for setting in sleeves. Knit to Row 158 (166) [172]. put half the sts. on the left into holding position and complete the right side first. *SHAPE SHOULDER AND NECK AT THE SAME TIME. FOR SHOULDER, bind off 7 sts. 4x. (6 sts. 5x). [6 sts. 4x, 9 sts. 1x]. FOR NECK, bind off 14 sts. 1x then 3 sts. 2x for all sizes. Bring the needles on the left into working position and knit 1 row to the left side, turn the Row Counter back to 158 (166) [172] and complete the left half. Follow the instructions from *.

SLEEVES: III

Cast on 80 (84) [84] sts. with color 1 and work 10 rows Ribbing. Continue in Stockinette stitch and Border Design. Work 2 rows color 1 then the 8 rows of Border Design. Continue in Stockinette stitch with color 1. Knit to Row 52 (56) [56]. Bind off.



KK 757

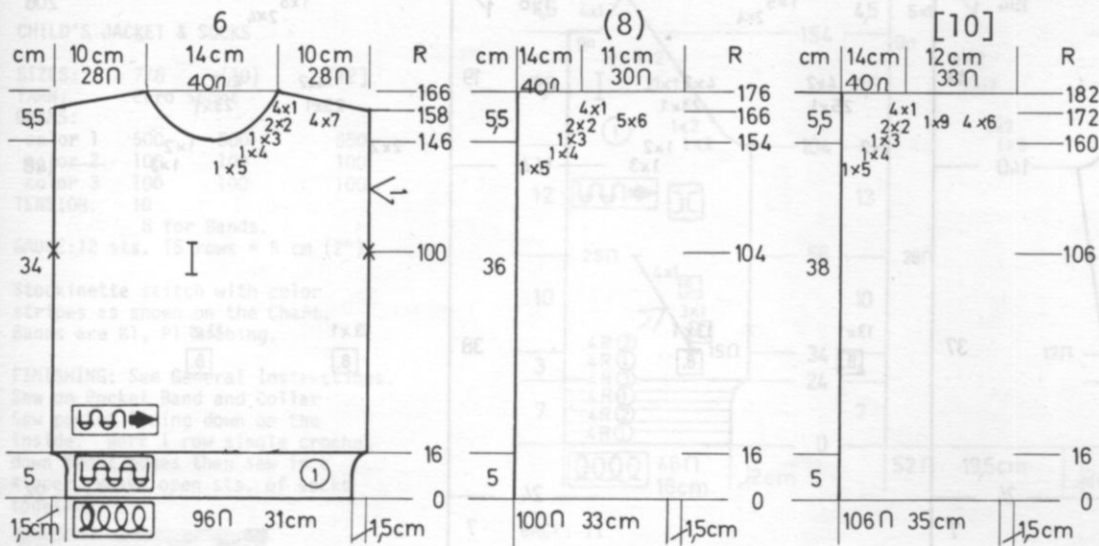

FRONT: I

Cast on 96 (100) [106] sts. with color 1 and work 16 rows Ribbing. Transfer the Ribber sts. and with color 1, work 2 rows, then work the Norwegian Border Design. After Row 26, knit 2 rows Stockinette stitch then work the isolated train design (see picture) on the LEFT - 10 sts. in from center. Continue in Stockinette stitch with color 1.
ON EACH SIDE, mark Row 100 (104) [106] for setting in sleeves then knit to Row 146 (154) [160].

Put half the sts. on the left into holding position and complete the right side first.
*ON NECK SIDE, for all sizes, bind off 5 sts. 1x, 4 sts. 1x, 3 sts. 1x, 2 sts. 2x, 1 st. 4x and after Row 158 (166) [172], SHAPE SHOULDER same as the back.
Bring the needles on the left into working position, knit 1 row to the left side, turn the Row Counter back to 146 (154) [160] and complete the left half. Follow the instructions from *.

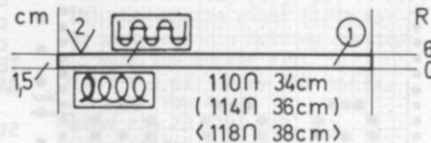
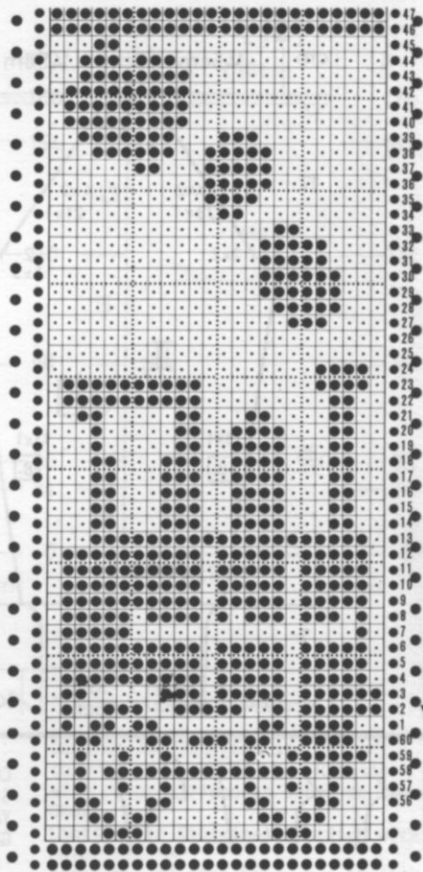

KK 758

CHILD'S VEST

SIZES: 6 (8) [10]
YARN: Euro Sport
GRAMS: 250 250 300
TENSION: 7 to 9
GAUGE: 14 sts. 18 rows = 5 cm (2")

Stockinette stitch with a Cable Design. Bands are K1, P1 Ribbing.

FINISHING: See General Instructions. Sew lining down on the inside.

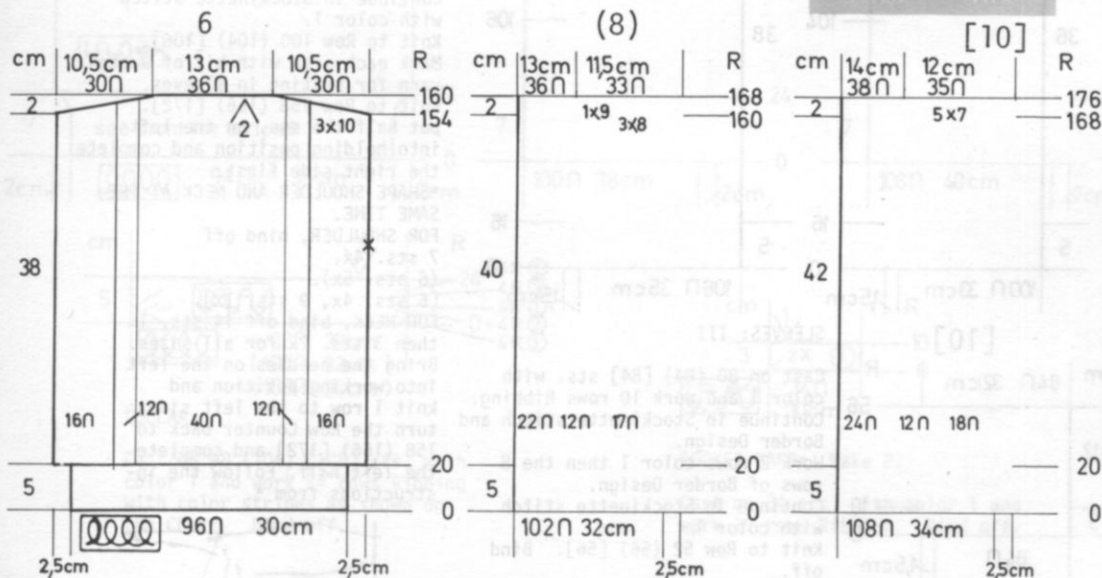

BACK:
Cast on 96 (102) [108] sts. and work 20 rows Ribbing. Continue in Stockinette stitch with Cable Design. Set up for Cables as shown on the Chart for size you need. 12 sts. form the pattern - 3 purl sts, 6 knit sts., 3 purl sts. After every 10th row, cross the center 6 knit sts. to form cable. After Row 154 (160) [168], SHAPE SHOULDER: ON EACH SIDE, bind off 10 sts. 3x. (8 sts. 3x, 9 sts. 1x). [7 sts. 5x]. After Row 160 (168) [176], bind off the remaining sts.

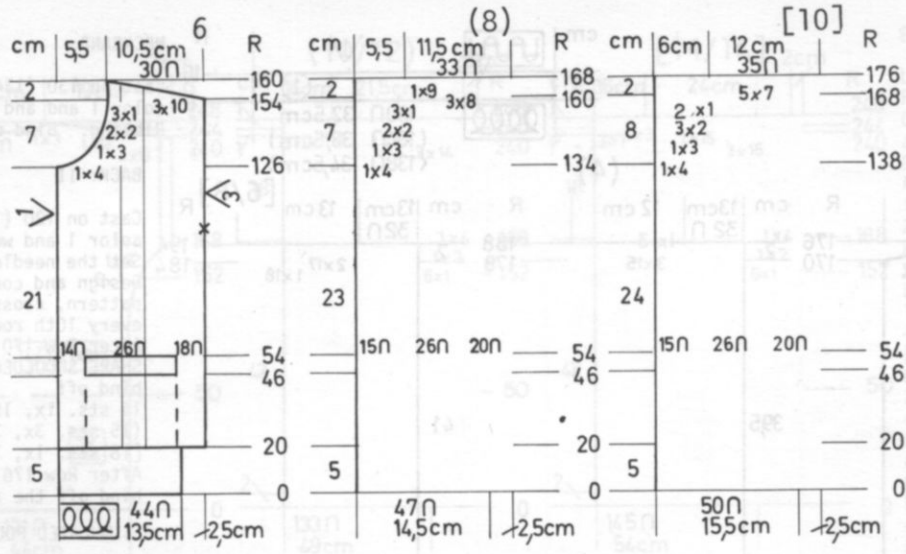

FRONT: Make 1, reverse 1.
 Work the Pocket lining first. Cast on 26 sts. and work 30 rows Stockinette stitch. Remove these sts. onto stitch holder. Make another pocket lining the same.
 FRONT: Cast on 44 (47) [50] sts. and work 20 rows Ribbing. Continue in Stockinette stitch and Cable Design as shown on the Chart for size you need. Work the Cables the same as the back and after Row 46, put 18 (20) [20] sts. on the right and 14 (15) [15] sts. on the left into holding position (reverse for 2nd section).
 Over the 26 remaining sts. work 8 rows Ribbing, then bind off these sts.
 Hang the pocket lining sts. onto the empty needles and continue in Stockinette stitch with Cable Design.

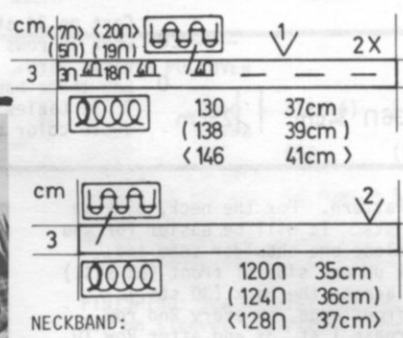

FRONT BANDS: Make 2.
 Cast on 130 (138) [146] sts. and work 16 rows Ribbing. Bind off.
 Work the 2nd band the same but make BUTTONHOLES as follows after Row 8. Counting from the left, leave 3 (5) [7] sts. make BUTTONHOLE over the next 4 sts. then leave *18 (19) [20] sts. and make BUTTONHOLE over the next 4 sts. Space the remaining buttonholes following the instructions from *. After Row 16, bind off.

After Row 125 (133) [137], SHAPE NECK: Bind off 4 sts. 1x, 3 sts. 1x, 2 sts. 2x, 1 st. 3x.
 (4 sts. 1x, 3 sts. 1x, 2 sts. 2x, 1 st. 3x).
 [4 sts. 1x, 3 sts. 1x, 2 sts. 3x, 1 st. 2x].
 After Row 154 (160) [168], SHAPE SHOULDER same as the back.

NECKBAND: Cast on 120 (124) [128] sts. and work 16 rows Ribbing. Bind off.

KK 759

CHILD'S PULLOVER

SIZES: 3 (4) [6/8]
 YARN: Euro Sport
 GRAMS: color 1 200 200 250
 color 2 100 100 150
 TENSION: 7 or 8
 GAUGE: 20 sts. 18 rows = 5 cm (2")

FINISHING: See General Instructions. Sew on neck and arm bands.

CABLE DESIGN: *6 sts. on the machine, 1 st. on Ribber and REPEAT from * across. After every 10th row, cross the 6 knit sts. for the Cable Design.

Stockinette stitch with a Cable Design. Bands are K1, P1 Ribbing.

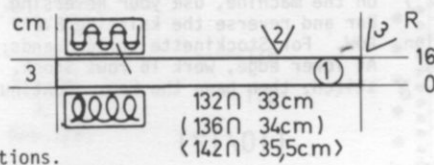

ARBANDS: Make 2.
 Cast on 132 (136) [142] sts. with color 1 and work 16 rows Ribbing. Bind off.

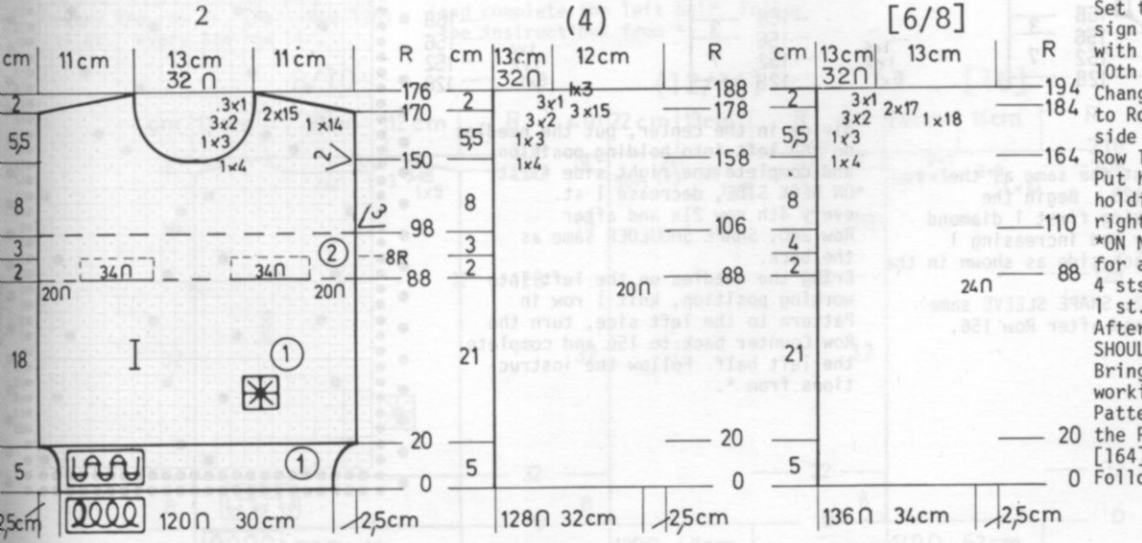

FRONT: I
 Cast on 120 (128) [136] sts. with color 1 and work 20 rows Ribbing. Set the needles for the Cable Design same as the back and continue with color 1 and Cables every 10th row to Row 88.
 Change to color 2 and continue to Row 98 (106) [110]. Mark each side for armbands then knit to Row 150 (158) [164]. Put half the sts. on the left into holding position and complete the right side first.
 *ON NECK SIDE, bind off for all sizes, 4 sts. 1x, 3 sts. 1x, 2 sts. 3x, 1 st. 3x.
 After Row 170 (178) [184], SHAPE SHOULDER same as the back. Bring the needles on the left into working position, knit 1 row in Pattern to the left side, turn the Row Counter back to 150 (158) [164] and complete the left half.
 Follow the instructions from *



KK 759

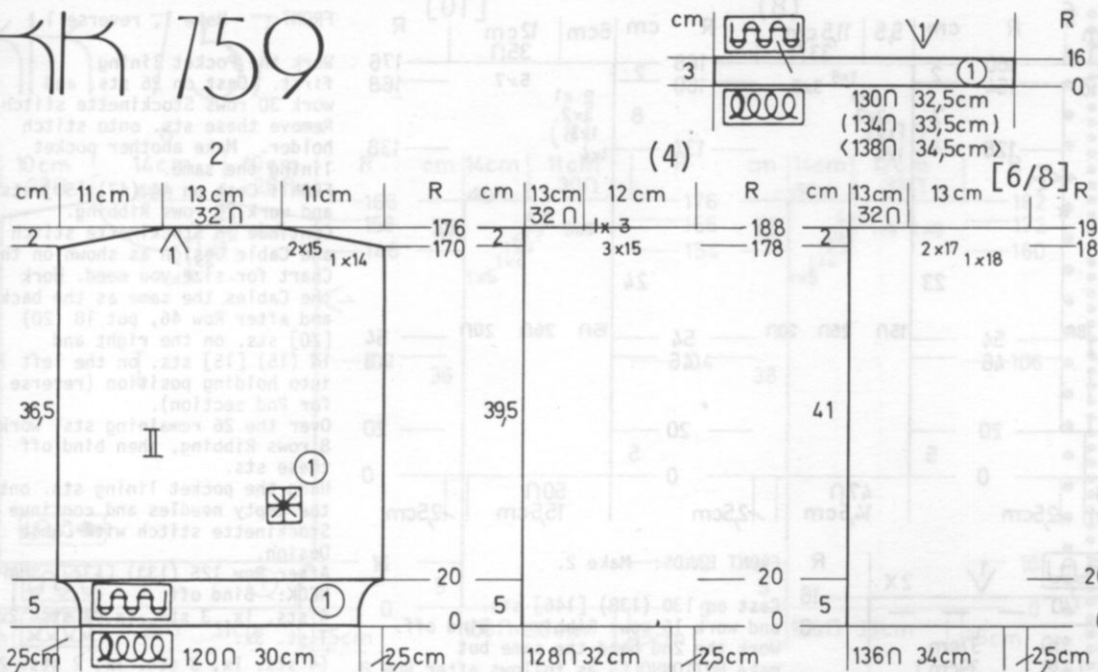

dk 760

WOMAN'S BLOUSE
(Sorry, there is no pattern for the Jacket, Scarf or Hat.)

SIZES: 8 (10/12) [14/16]
YARN: Micaela
GRAMS: 250 250 300
TENSION: 6 to 8
GAUGE: 13 1/2 sts. 20 rows = 5 cm (2")

Stockinette stitch with a Lace Design. Punch your own Card. See Finishing instructions for the bands.

FINISHING: See General Instructions. You can pick up the open sts. and work Garter Stitch by hand for 12 rows (6 ridges) For the Sleeves, pick up 104 sts. For the neckline, pick up 62 sts. on each side of front neckline and 30 sts. across the back and work 8 rows garter stitch (4 ridges) and on EVERY 2nd row, ON EACH SIDE of center neck, knit 2 together to shape the V. OR - you can make the bands on the machine. For garter stitch on the machine, use your Reversing Bar and reverse the knitting EVERY ROW. For Stockinette stitch bands: At lower edge, work 16 rows Stock. stitch, then hang the hem. Continue

in Pattern. For the neck, pick up 162 sts. It will be easier for you to close one shoulder seam and pick up one side of front (62 sts.) and across the back (30 sts.). *At front edge, on every 2nd row, decrease 1 st. 3x and after Row 10, increase 1 st. 3x. After Row 16, remove onto waste yarn. Pick up 62 sts. along other front edge and REPEAT from *. For the sleeve bands, pick up 104 sts. and work 16 rows Stockinette stitch. Fold bands in half and sew down on the inside through the open sts. Close points at center front. BELT: Make a cord over 5 needles, approximately 160 cm (63") long. Pull through top eyelets at waist.

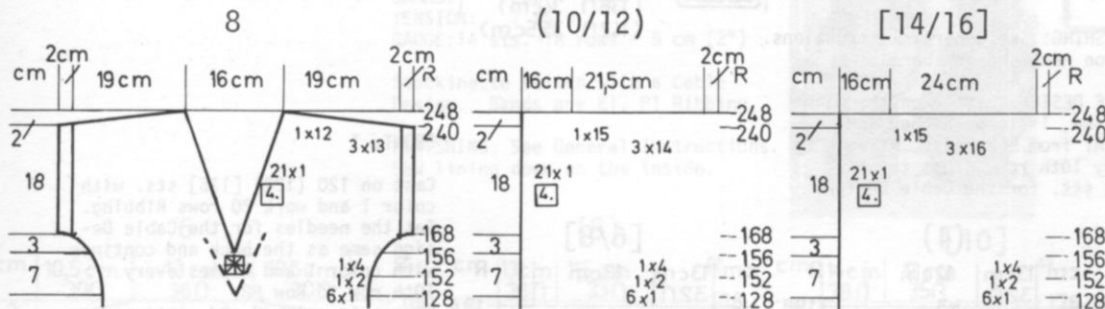

FRONT: I

Work the front the same as the back to Row 128. Begin the Pattern, working first 1 diamond in the center and increasing 1 diamond on each side as shown in the picture. After Row 152, SHAPE SLEEVE same as the back and after Row 156,

divide in the center, put the needles on the left into holding position and complete the right side first. *ON NECK SIDE, decrease 1 st. every 4th row 21x and after Row 240, SHAPE SHOULDER same as the back. Bring the needles on the left into working position, knit 1 row in Pattern to the left side, turn the Row Counter back to 156 and complete the left half. Follow the instructions from *.

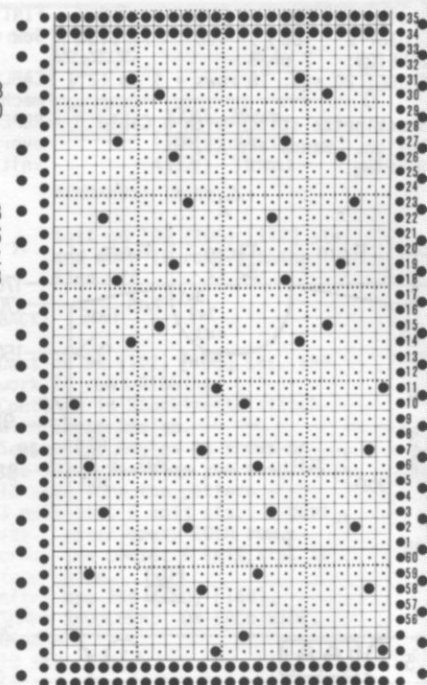

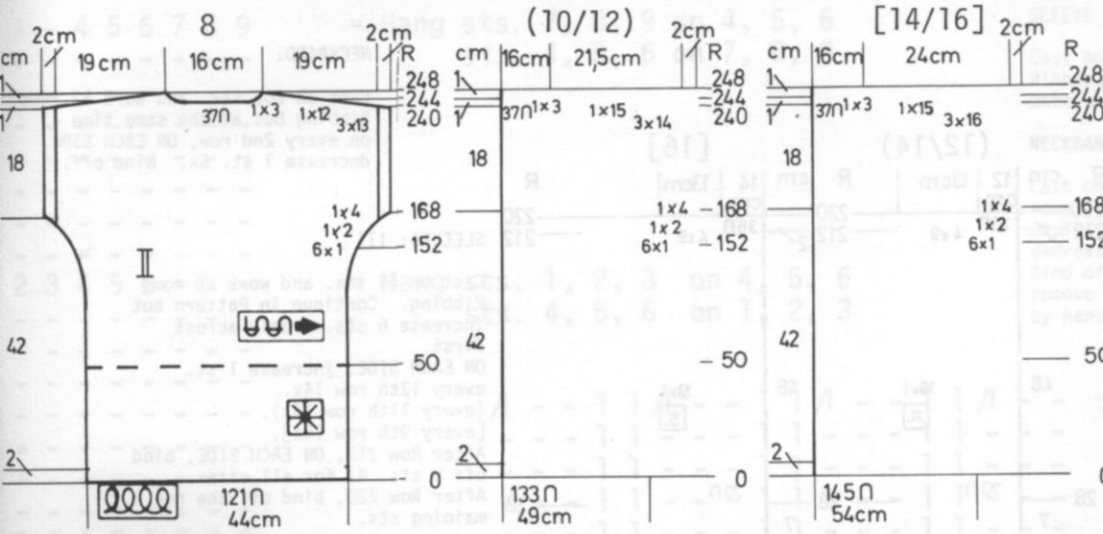

BACK: II
 USE CAST ON OF YOUR CHOICE - See Finishing Instructions.
 Cast on 121 (133) [145] sts. and work in Pattern to Row 50. Continue in Stockinette stitch. After Row 152, ON EACH SIDE, increase 1 st. every 2nd row 6x, 2 sts. 1x, 4 sts. 1x, for all sizes. Knit to Row 240.
 SHAPE SHOULDER: ON EACH SIDE, bind off (WATCH FOR NECK SHAPING) 13 sts. 3x, 12 sts. 1x, (14 sts. 3x, 15 sts. 1x), [16 sts. 3x, 15 sts. 1x], BUT AT THE SAME TIME, after Row 244 SHAPE NECK: Bind off the center 37 sts., put the needles on the left into holding position and complete the right side first. ON NECK SIDE, bind off 3 sts. 1x.
 0 Bring the needles on the left into working position, knit 1 row in Pattern to the left side, turn the Row Counter back to 244 and complete the left half. Follow the instructions from * and don't forget to complete the shoulder shaping.

dk 761

WOMAN'S PULLOVER
 SIZES: 8/10 (12/14) [16]
 YARN: Amore
 GRAMS: 450 450 (500)
 TENSION: 5 to 7
 GAUGE: 13 1/2 sts. 20 rows = 5 cm (2")
 An Eyelet Design. Punch your own Card. Bands are K1, P1 Ribbing.
 FINISHING: See General Instructions. Sew on sleeves for markers. Sew on neckband.

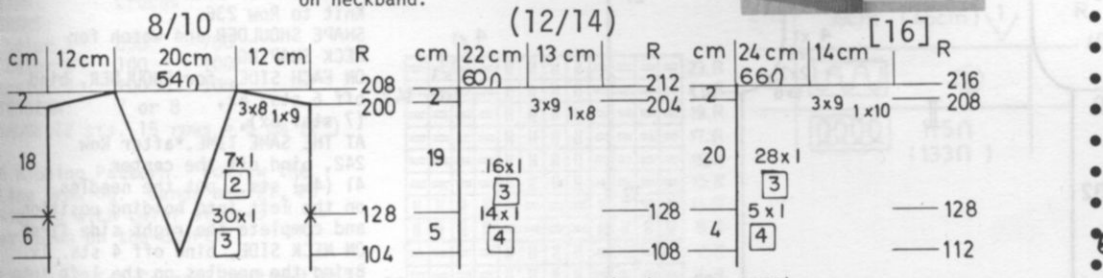
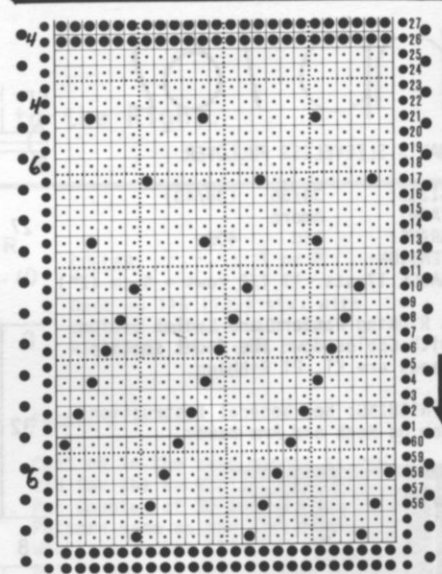

FRONT: I
 Work the front the same as the back to Row 104 (108) [112]. Divide in the center, put the needles on the left into holding position and complete the right side first.
 *ON NECK SIDE, bind off 1 st. every 3rd row 30x, every 2nd row 7x. (Mark Row 128) (1 st. every 4th row 14x,

every 3rd row 16x). (Mark Row 128) [1 st. every 4th row 5x, every 3rd row 28x]. (Mark Row 128) AT THE SAME TIME, after Row 200 (204) [208], SHAPE SHOULDER same as the back Bring the needles on the left into working position, knit 1 row in Pattern to the left side, turn the Row Counter back to 104 (108) [112] and complete the left half. Follow the instructions from *.

BACK: II
 Cast on 120 (130) [140] sts. and work 32 rows Ribbing. Continue in Pattern and be sure to note the Stockinette stitch Rows as marked on the left side of card. Knit to Row 128. Mark each edge with contrast yarn for setting in sleeves. Knit to Row 200 (204) [208].
 SHAPE SHOULDER AND NECK AT THE SAME TIME: Bind off the center 44 (50) [56] sts., put the needles on the left into holding position and complete the right side first.
 *FOR SHOULDER, bind off 9 sts. 1x, 8 sts. 3x, (8 sts. 1x, 9 sts. 3x), [10 sts. 1x, 9 sts. 3x], FOR NECK, bind off 3 sts. 1x, 1 st. 2x for all sizes. Bring the needles on the left into working position, knit 1 row in pattern to the left side, turn the Row Counter back to 200 (204) [208] and complete the left half. Follow the instructions from *.

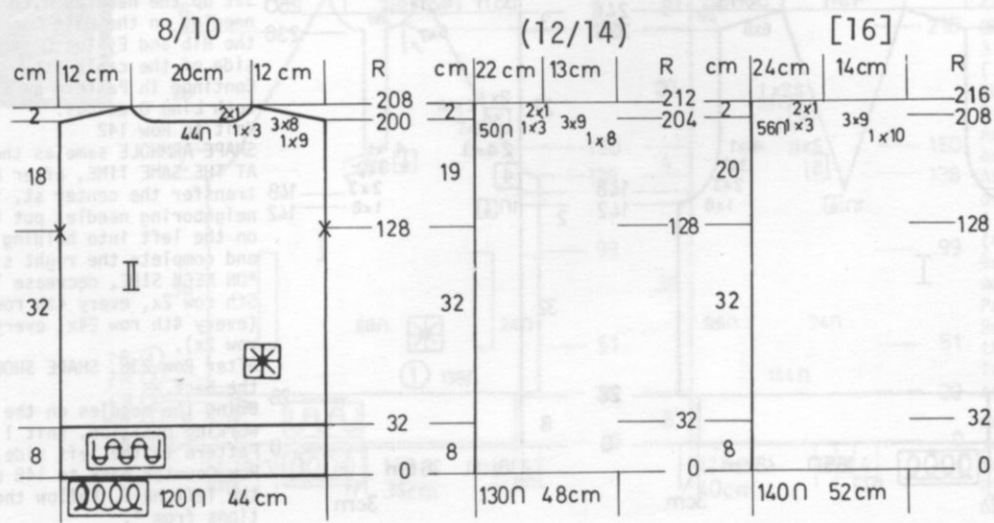

dk 761

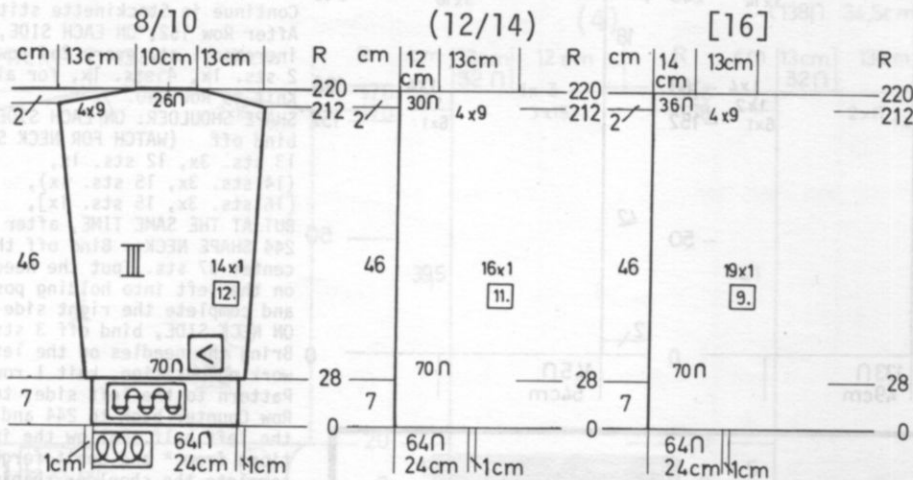

NECKBAND:

Cast on 200 sts. and work 12 rows Ribbing but at the same time on every 2nd row, ON EACH SIDE, decrease 1 st. 6x. Bind off.

SLEEVES: III

Cast on 64 sts. and work 28 rows Ribbing. Continue in Pattern but increase 6 sts. evenly across first.
ON EACH SIDE, increase 1 st. every 12th row 14x. (every 11th row 16x). [every 9th row 19x].
After Row 212, ON EACH SIDE, bind off 9 sts. 4x for all sizes.
After Row 220, bind off the remaining sts.

hp 762

MAN'S SLEEVELESS PULLOVER

SIZES: 34/36 (38/40)
YARN: Amore
GRAMS: 350 400
TENSION: 5 to 7
GAUGE: 17 sts. 17 1/2 rows = 5 cm (2")

A Ribbing Pattern and Eyelet Design with Cables down the front section. Bands are K1, P1 Ribbing.

FINISHING: See General Instructions. Sew on Neck and Arm Bands.

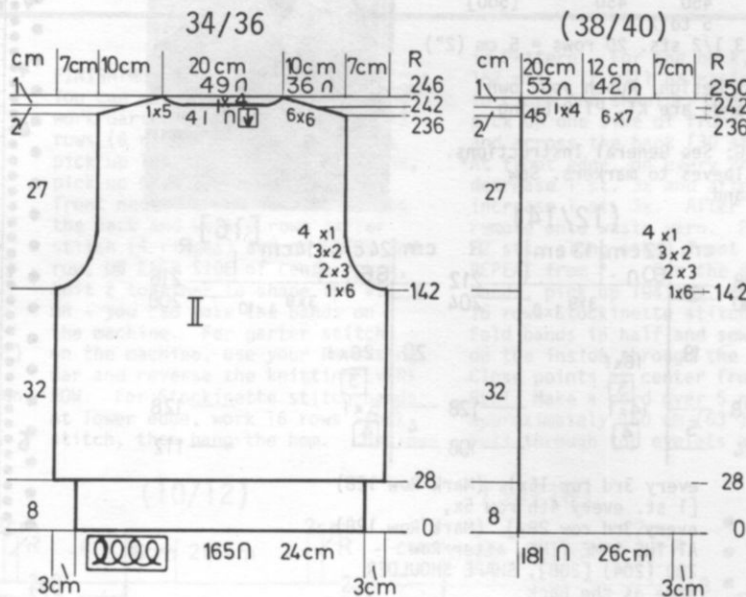

BACK: II

Cast on 165 (181) sts. and work 28 rows Ribbing. Continue in Rib and Eyelet Design following the Line Drawing.
Knit to Row 142.
SHAPE ARMHOLE: ON EACH SIDE, bind off 6 sts. 1x, 3 sts. 2x, 2 sts. 3x, 1 st. 4x for both sizes.
Knit to Row 236.
SHAPE SHOULDER and watch for NECK SHAPING.
ON EACH SIDE, for SHOULDER, bind off 6 sts. 6x, (7 sts. 6x),
AT THE SAME TIME, *after Row 242, bind off the center 41 (45) sts., put the needles on the left into holding position and complete the right side first.
ON NECK SIDE, bind off 4 sts. 1x. Bring the needles on the left into working position, knit 1 row in Pattern to the left side, turn the Row Counter back to 242 and complete the left half. Follow the instructions from * and don't forget to complete the shoulder shaping.

FRONT: I

Cast on 165 (181) sts. and work 28 rows Ribbing.
Set up the needles with the 9 center needles on the main machine with the Rib and Eyelet Design on each side of the cable sts.
Continue in Pattern as shown on both Line Drawings.
Knit to Row 142
SHAPE ARMHOLE same as the back but AT THE SAME TIME, after Row 148, transfer the center st. to its neighboring needle, put the sts. on the left into holding position and complete the right side first.
*ON NECK SIDE, decrease 1 st. every 5th row 2x, every 4th row 22x. (every 4th row 24x, every 3rd row 2x).
After Row 236, SHAPE SHOULDER same as the back.
Bring the needles on the left into working position, knit 1 row in Pattern to the left side, turn the Row Counter back to 148 and complete the left half. Follow the instructions from *.

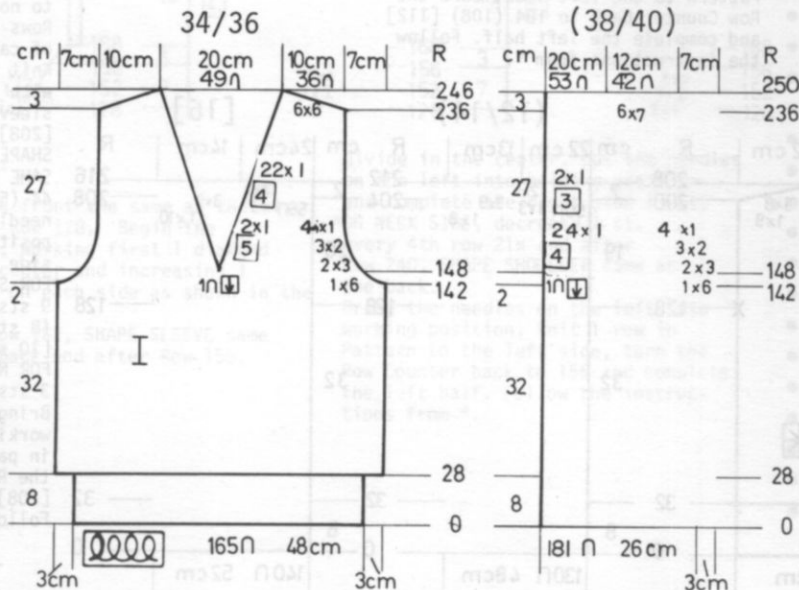

- - 4 5 6 7 8 9
 - - - - -
 - - - - -
 - - - - -
 - - - - -
 - - - - -
 - - - - -
 - - - - -
 - - - - -
 - - - - -
 2 3 4 5 6 - - -
 - - - - -
 - - - - -
 - - - - -
 - - - - -
 - - - - -
 - - - - -
 - - - - -
 - - - - -
 2 3 4 5 6 7 8 9

= Hang sts. 7, 8, 9 on 4, 5, 6
 sts. 4, 5, 6 on 7, 8, 9

ENTER CABLE PATTERN

= Hang sts. 1, 2, 3 on 4, 5, 6
 sts. 4, 5, 6 on 1, 2, 3

/ - - 1 1 / - - 1 1 / - - 1 1 / - -
 - - 1 1 - - 1 1 - - 1 1 - -
 - - 1 1 - - 1 1 - - 1 1 - -
 - - 1 1 - - 1 1 - - 1 1 - -
 - - 1 1 - - 1 1 - - 1 1 - -
 - - 1 1 - - 1 1 - - 1 1 - -
 - - 1 1 - - 1 1 - - 1 1 - -
 - - 1 1 - - 1 1 - - 1 1 - -

SLEEVE BANDS: Make 2.

Cast on 200 sts. and work 14 rows Ribbing. Bind off or you can remove onto waste yarn if you prefer.

NECKBAND: Make 2.

Cast on 140 sts. and work 14 rows Ribbing and AT THE SAME TIME, ON THE LEFT (right for 2nd half), decrease 2 sts. every 2nd row 7x. Bind off in Ribbing or you can remove onto waste yarn and bind off by hand.

LEGEND: - - = Knit Stitches
 1 1 = Pur1 Stitches
 / - = Transfer Knit Stitch to the Right.

763

MAN'S PULLOVER

SIZES: 38/40 (42/44)

YARN: Crocus

GRAMS:

color 1 650 700
 color 2 100 100
 color 3 100 100

TENSION: 7 or 8

GAUGE: 12 sts. 15 rows = 5 cm (2")

A Ribbing Pattern. Follow the Line Drawing. Bands are K1, P1 Ribbing with color stripes as shown on the Chart.

FINISHING: See General Instructions. Sew on Collar and Neckband.

==	==	==	==	==	==	==	==	==	==	==	23.R
==	==	==	==	==	==	==	==	==	==	==	21.R
==	==	==	==	==	==	==	==	==	==	==	19.R
==	==	==	==	==	==	==	==	==	==	==	17.R
==	==	==	==	==	==	==	==	==	==	==	15.R
==	==	==	==	==	==	==	==	==	==	==	13.R
==	==	==	==	==	==	==	==	==	==	==	11.R
==	==	==	==	==	==	==	==	==	==	==	9.R
==	==	==	==	==	==	==	==	==	==	==	7.R
==	==	==	==	==	==	==	==	==	==	==	5.R
==	==	==	==	==	==	==	==	==	==	==	3.R
==	==	==	==	==	==	==	==	==	==	==	1.R

cm	39cm (45cm)	↓	R
			40
10	☒☒☒☒	Ⓣ	
			0
	☐☐☐☐		115n (133n)

COLLAR:

Cast on 115 (133) sts. with color 2 and work 40 rows Ribbing. Bind off.

FRONT: I

Cast on in the same manner as you did for the Back. 136 (144) sts. Put Counter at 30 and work in Pattern same as the back to Row 50. Work the Pocket Slits. Put all but 24 sts. on the right into holding position and work 48 rows in Pattern. Put these sts. into holding and work in Pattern over the next 88 (96) sts. for 48 rows. Put sts. into holding and work over the next 24 sts. for 48 rows.



Break yarn and move Slide to the right side. Continue in Pattern over ALL THE NEEDLES. After Row 138, SHAPE ARMHOLES. ON EACH SIDE, bind off 3 sts. 2x, 2 sts. 2x, 1 st. 41x, (3 sts. 2x, 2 sts. 4x, 1 st. 39x), BUT AT THE SAME TIME, after Row 150, Bind off the center 8 sts. put the needles on left into holding position and complete the right side first. 138 *After Row 209, ON NECK SIDE, bind off 4 sts. 1x, 2 sts. 2x, 1 st. 5x. (4 sts. 1x, 2 sts. 4x, 1 st. 3x). Bring the needles on the left into working position, knit 1 row in Pattern to the left side, turn the Row Counter back to 150 and complete the left half. Follow the instructions from * continuing the raglan shaping at the same time.

Hang the open sts. held on waste yarn back onto the machine, decreasing to 120 (128) sts. Work 30 rows Ribbing with color stripes same as back then bind off

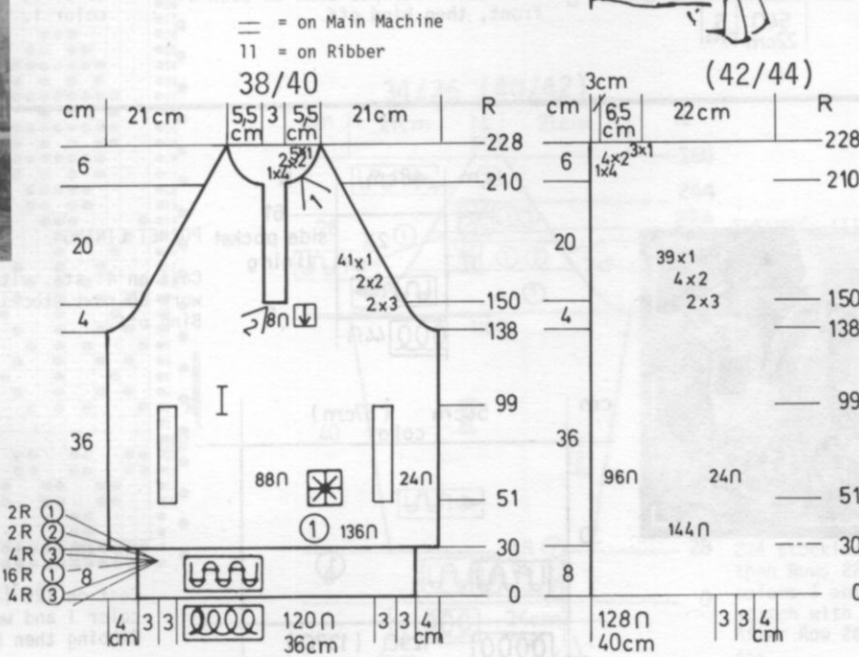

hp 763

BACK: II

POCKET LINING: Make 2.

Cast on 88 (96) sts. with color 1 and work 48 rows Stockinette stitch. Bind off.

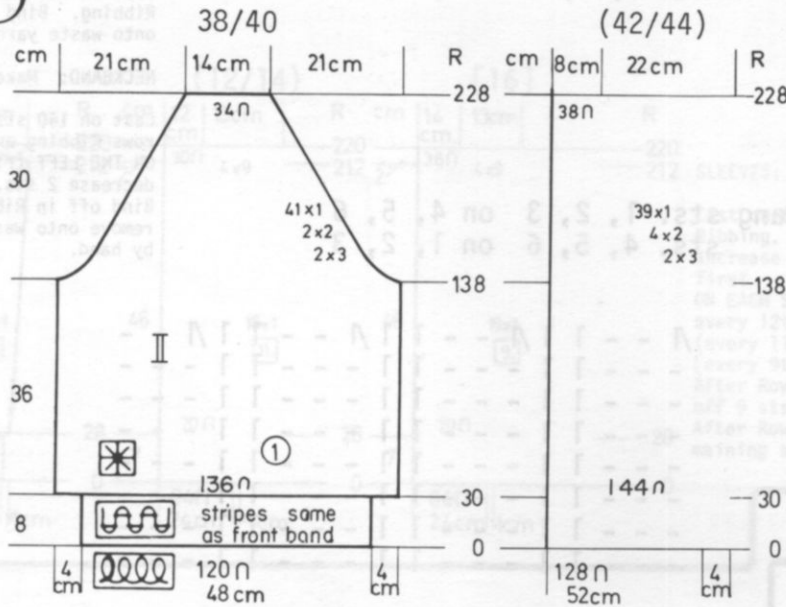

Use OPEN CAST ON FOR BACK, FRONT, AND SLEEVES because it is easier to decrease sts. for the band than to increase.

With waste yarn, cast on 136 (144) sts. After knitting 11 or 13 rows, knit 1 row with main yarn (color 1) the right. Transfer the sts. to the ribber as shown in the line drawing then put Counter at 30. Continue in Pattern. Knit to Row 138. SHAPE RAGLAN: ON EACH SIDE, bind off, 3 sts. 2x, 2 sts. 2x, then decrease 1 st. every 2nd row 41x. (3 sts. 2x, 2 sts. 4x, then decrease 1 st. every 2nd row 39x. After Row 228, bind off the remaining sts.

Hang the open sts. back onto the machine, decreasing to 120 (128) sts. Work 30 rows in Ribbing with color stripes as shown on the Chart. Bind off in Ribbing.

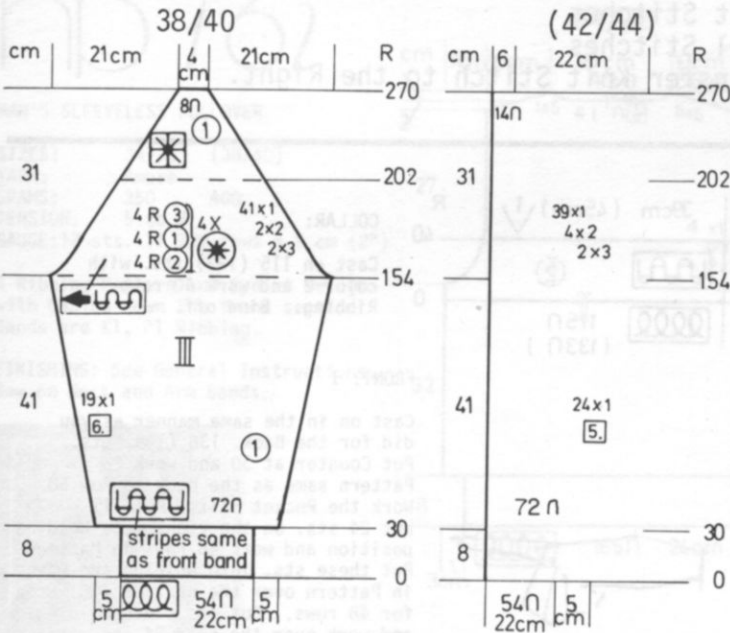

SLEEVES: III

Cast on in the same manner as you did for front and back. 72 sts. for both sizes. Put Counter at 30 and work in Pattern with color 1. ON EACH SIDE, increase 1 st. every 6th row 19x. (every 5th row 24x). After Row 154, continue in Stockinette stitch with color stripes as shown on the Chart and ON EACH SIDE, SHAPE RAGLAN: Bind off 3 sts. 2x, 2 sts. 2x, 1 st. 41x, (3 sts. 2x, 2 sts. 4x. 1 st. 39x), AND AT THE SAME TIME, after Row 202, Continue in Pattern to Row 270. Bind off the remaining sts.

Hang the sts. held on waste yarn back onto the machine, decreasing to 54 sts. Work 30 rows Ribbing with color stripes same as back & front, then bind off.

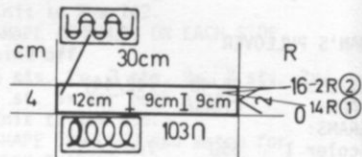

FRONT & COLLAR BAND: Make 2.

Cast on 103 sts. with color 1 and work in Ribbing. 14 rows color 1, 2 rows color 2. Bind off See Practical Knitting Hints in this issue for Buttonholes

POCKET BANDS: Make 2.

Cast on 41 sts. with color 3 and work in Ribbing, 2 rows color 3, 4 rows color 2, 8 rows color 1. Bind off

hp 764

MAN'S JACKET

SIZES: 34/36 (40/42)

YARN: Vienna

GRAMS:

color 1 800 850

color 2 100 100

color 3 50 50

TENSION: 5 to 7

GAUGE: 12 sts. 18 rows = 5 cm (2")

Stockinette stitch and Norwegian Designs. Punch your own Cards. Bands are K1, P1 Ribbing.

FINISHING: See General Instructions. Leave pocket slits open when sewing side seams. Sew pocket lining to back edge and inside to the front. Sew Breast pocket in place. Sew on Collar. Work single crochet down fronts then sew in zipper.

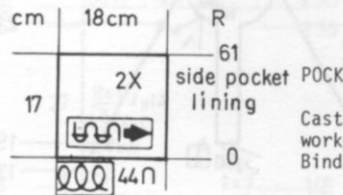

POCKET LINING

Cast on 44 sts. with color 1 and work 60 rows Stockinette stitch. Bind off.

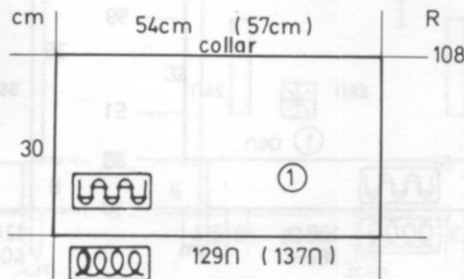

COLLAR:

Cast on 129 (137) sts. with color 1 and work 108 rows Ribbing then bind off.

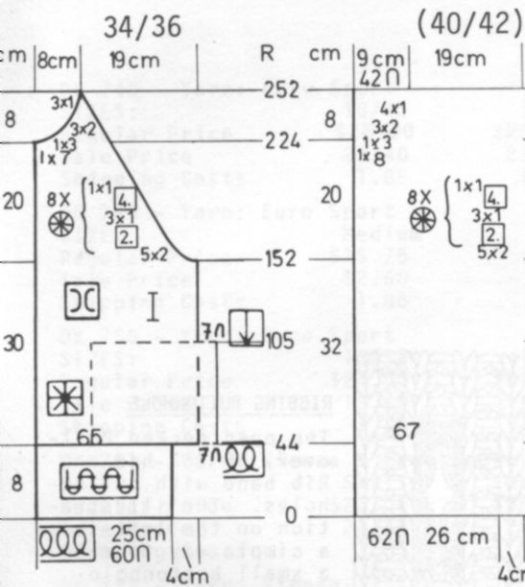

FRONT: I Make 1, reverse 1.

Cast on 60 (62) sts. with color 1 and work 44 rows Ribbing. Increase 5 sts. evenly across then cast on 7 sts. on the right side (left for second section). Keep these 7 cast on sts. in Stockinette stitch and continue in Pattern.

After Row 105, remove the 7 sts. for pocket facing onto a stitch holder or you can bind them off. Knit to Row 152 (160).

SHAPE RAGLAN same as the back but AT THE SAME TIME, after Row 223, SHAPE NECK: Bind off 7 sts. 1x, 3 sts. 1x, 2 sts. 3x, 1 st. 3x. (8 sts. 1x, 3 sts. 1x, 2 sts. 3x, 1 st. 4x.

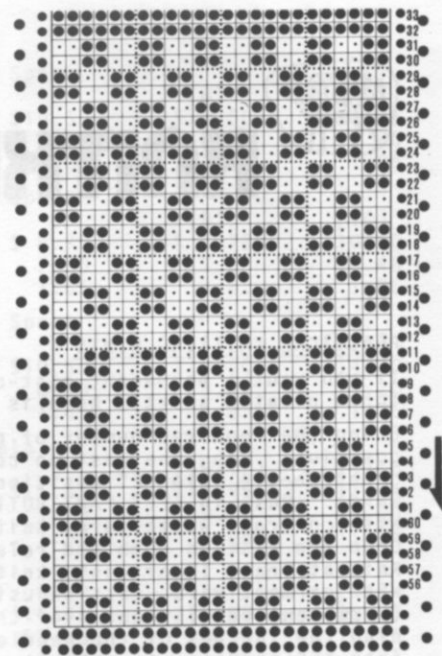

BACK: II

Cast on 112 (116) sts. with color 1 and work 44 rows Ribbing. Increase 18 sts. across, knit 2 rows then continue in Pattern I. When Pattern is completed, continue in Stockinette stitch. Knit to Row 152 (160).

SHAPE RAGLAN: ON EACH SIDE, bind off (all sizes) 2 sts. 5x, then *decrease 1 st. every 2nd row 3x, every 4th row 1x and REPEAT from * 8x more. After Row 252 (260), bind off the remaining sts.

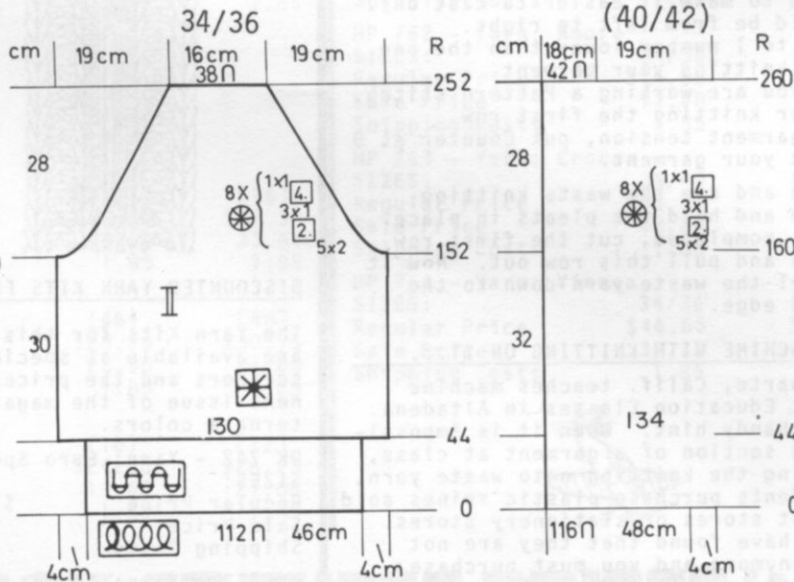

PATTERN II

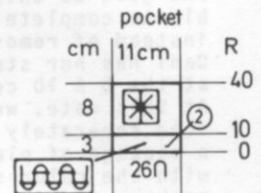

BREAST POCKET

Cast on 26 sts. with color 2 and work 10 rows Ribbing. Continue in Pattern II with colors 1 and 2 to Row 40. Bind off.

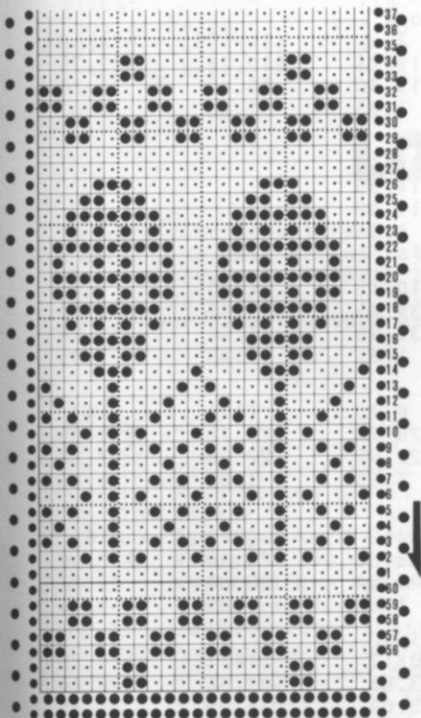

PATTERN I

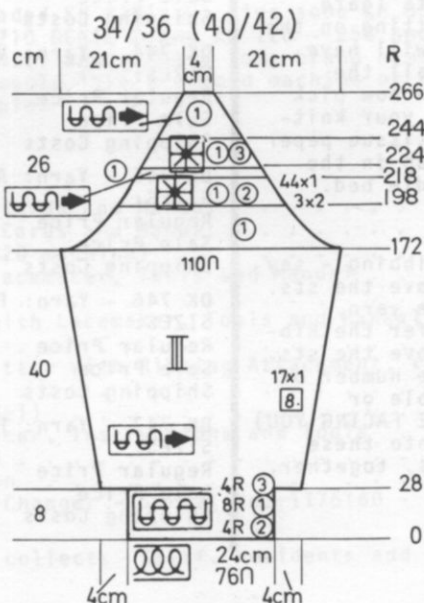

SLEEVES: III

Cast on 76 sts. with color 2 and work in Ribbing with color stripes as shown on the chart then continue with color 1.

After Row 28, change to Stockinette stitch.

ON EACH SIDE, increase 1 st. every 8th row 17x.

After Row 172, SHAPE RAGLAN: ON EACH SIDE, bind off 2 sts. 3x then 1 st. 44x BUT AT THE SAME TIME After Row 198, work Pattern II with colors 1 and 2, Rows 218 to 224 stockinette stitch with color 1 then Rows 225 to 244 Pattern II with colors 1 and 3. Continue Stockinette stitch with color 1.

After Row 266, bind off the remaining sts.



KNITTING NEWS

PRACTICAL KNITTING HINTS

If you want a permanent cast-on edge (for instance for a pleated skirt), here is an easy way.

Bring the required number of needles into working position. Hang the cast on comb. Bring every other needle into "E" position (all the way forward). Push in LEFT PART BUTTON.

With contrast waste yarn, knit 1 row to the left. Drop the cast on comb and release part button. Knit at least 1" of waste knitting.

With garment yarn, cast on using the "e" method (permanent edge) right over the waste yarn, behind the latches of the needles (bring the needles into "E" position to make it easier to cast on). The cast on should be from left to right.

Turn the tension to 1 number lower than the one you will use for knitting your garment.

Knit 2 rows. If you are working a Pattern stitch, set the card after knitting the first row.

Turn Tension to garment tension, put Counter at 0 and continue with your garment.

Block the section and use the waste knitting to push pins into and hold the pleats in place. After blocking is completed, cut the first row of the waste yarn and pull this row out. Now it is easy to unravel the waste yarn down to the permanent cast on edge.

TRANSPORT YOUR MACHINE WITH KNITTING ON IT...

Dani Carver of Duarte, Calif. teaches machine knitting at Adult Education Classes in Altadena. She gave us this handy hint. When it is impossible to complete a section of a garment at class, instead of removing the knitting onto waste yarn, Dani has her students purchase plastic spines sold at the 5 & 10 cent stores or stationery stores. At this date, we have found that they are not sold separately anymore and you must purchase a package of plastic paper holders which come with the color spines. There are 4 or 6 in a package and they cost approximately \$1.00. Use the spines to slip over the front posts (gate pegs) of your machine - leave the knitting on the machine ready for the next row. You will have to use enough of the spines to cover all the stitches (they are 11" long). You can now pick up the machine without worrying about your knitting. If you remember to carry some tissue paper with you, you can roll your knitting up in the tissue and place it on top of the needle bed.

NARROW BANDS OF RIBBING

When you must have a narrow band of Ribbing - say 6 or 8 rows, it is much easier to remove the sts. of the band when completed, onto waste yarn. When you have knitted the band, transfer the Ribber sts. to the main machine then remove the sts. onto contrast waste yarn. Pick up the number of required sts. around a neckline, armhole or wherever you need the band (WRONG SIDE FACING YOU) then hang the open sts. of the band onto these same needles. Bind off the double sts. together.

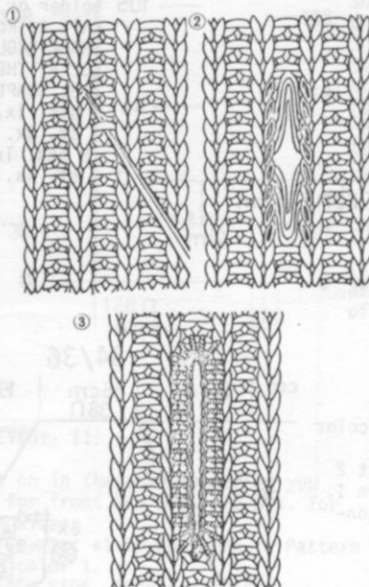

RIBBING BUTTONHOLE

The open necked Pull-over, HP 763 has a Rib band with buttonholes. The illustration on the left shows a simple way to make a small buttonhole. With a crochet hook, spread and pull the knitting apart for as many rows needed for an opening. Tack the opening at each end then work a buttonhole stitch all around the opening. Use matching buttonhole twist or fine matching yarn.

DISCOUNTED YARN KITS FOR THIS ISSUE

The Yarn Kits for this issue of KNITTING MAGAZINE are available at special discounts to our subscribers and the prices are only good until the next issue of the magazine. Be sure to give alternate colors.

DK 742 - Yarn: Euro Sport			
SIZES:	7/8	(10/12)	[14/16]
Regular Price	\$19.25	\$19.25	\$22.75
Sale Price	15.40	15.40	18.20
Shipping Costs	1.85	1.85	1.85
DK 743 - Yarn: Amore			
SIZE:	12/14		
Regular Price	\$14.35		
Sale Price	11.48		
Shipping Costs	1.85		
DK 744 - Yarn: Vienna			
SIZES:	10/12	(14)	[16]
Regular Price	\$39.95	\$39.95	\$42.30
Sale Price	31.96	31.96	33.84
Shipping Costs	1.85	1.85	1.85
DK 745 - Yarn: Amore			
SIZES:	8/10	(12)	[14]
Regular Price	\$28.70	\$28.70	\$34.85
Sale Price	22.96	22.96	27.88
Shipping Costs	1.85	1.85	1.85
DK 746 - Yarn: Fortissima			
SIZES:	10/12	(14)	[16]
Regular Price	\$25.80	\$25.80	\$30.96
Sale Price	20.64	20.64	24.77
Shipping Costs	1.85	1.85	1.85
DK 747 - Yarn: Fortissima			
SIZES:	10/12	(14/16)	[18.20]
Regular Price	\$43.86	\$43.86	\$46.44
Sale Price	35.09	35.09	37.15
Shipping Costs	1.85	1.85	1.85

DK 748 - Yarn: Euro Sport			
SIZES:	10/12	(14)	[16]
Regular Price	\$28.00	\$28.00	\$29.75
Sale Price	22.40	22.40	23.80
Shipping Costs	1.85	1.85	1.85
DK 749 - Yarn: Euro Sport			
SIZE:	Medium		
Regular Price	\$15.75		
Sale Price	12.60		
Shipping Costs	1.85		
DK 750 - Yarn: Euro Sport			
SIZES:	10/12	(14)	[16]
Regular Price	\$24.50	\$24.50	\$26.25
Sale Price	19.60	19.60	21.00
Shipping Costs	1.85	1.85	1.85
DK 751 - Yarn: Vienna & Euro Sport			
SIZES:	Small	Medium	Large
Regular Price	\$28.05	\$28.05	\$29.80
Sale Price	22.44	22.44	23.84
Shipping Costs	1.85	1.85	1.85
DK 752 - Yarn: Vienna			
SIZES:	6/8	(10)	[12]
Regular Price	\$39.20	\$39.20	\$41.55
Sale Price	31.68	31.68	33.56
Shipping Costs	1.85	1.85	1.85
DK 753 - Yarn: Vienna			
SIZES:	10/12	(14)	
Regular Price	\$35.10	\$39.20	
Sale Price	28.08	31.36	
Shipping Costs	1.85	1.85	
DK 754 - Yarn: Vienna			
SIZES:	10	(12/14)	[16]
Regular Price	\$39.95	\$42.30	\$42.30
Sale Price	31.96	33.84	33.84
Shipping Costs	1.85	1.85	1.85
HP 755 - Yarn: Amore			
SIZES:	40/44	(46)	[48]
Regular Price	\$28.70	\$28.70	\$30.75
Sale Price	22.96	22.96	24.60
Shipping Costs	1.85	1.85	1.85
KK 756 - Yarn: Euro Sport			
SIZES:	7/8	(10)	[12]
Regular Price	\$24.50	\$24.50	\$26.25
Sale Price	19.60	19.60	21.00
Shipping Costs	1.85	1.85	1.85

KK 757 - Yarn: Euro Sport			
SIZES:	6	(8)	[10]
Regular Price	\$10.50	\$10.50	\$12.25
Sale Price	8.40	8.40	9.80
Shipping Costs	1.85	1.85	1.85
KK 758 - Yarn: Euro Sport			
SIZES:	6	(8)	[10]
Regular Price	\$ 8.75	\$ 8.75	\$10.50
Sale Price	7.00	7.00	8.40
Shipping Costs	1.85	1.85	1.85
KK 759 - Yarn: Euro Sport			
SIZES:	3	(4)	[6/8]
Regular Price	\$10.50	\$10.50	\$14.00
Sale Price	8.40	8.40	11.20
Shipping Costs	1.85	1.85	1.85
DK 760 - Yarn: Micaela			
SIZES:	8	(10/12)	[14/16]
Regular Price	\$11.45	\$11.45	\$13.74
Sale Price	9.16	9.16	10.99
Shipping Costs	1.85	1.85	1.85
DK 761 - Yarn: Amore			
SIZES:	8/10	(12/14)	[16]
Regular Price	\$18.45	\$18.45	\$20.50
Sale Price	14.76	14.76	16.40
Shipping Costs	1.85	1.85	1.85
HP 762 - Yarn: Amore			
SIZES:	34/36	(38/40)	
Regular Price	\$14.35	\$16.40	
Sale Price	11.48	13.12	
Shipping Costs	1.85	1.85	
HP 763 - Yarn: Crocus			
SIZES:	38/40	(42/44)	
Regular Price	\$53.55	\$56.70	
Sale Price	42.84	45.36	
Shipping Costs	1.85	1.85	
HP 764 - Yarn: Vienna			
SIZES:	34/36	(40/42)	
Regular Price	\$44.65	\$47.00	
Sale Price	35.72	37.60	
Shipping Costs	1.85	1.85	



LOOK AT THESE PRICES!!

We have some Demonstrators and Traded KH 830's... plus some KH 820's... all rebuilt in like new condition... We have demonstrator KH 710 GENIE'S and KH 120 - 258 needle machines in like new condition... We also have demo JUMBO'S like new... and we have some brand name traded machines in excellent condition all at LOW LOW prices... If you would like a second machine or have a friend looking for a 'good buy', place your order as soon as possible.

	REGULAR PRICE	SALE PRICE
KH 830 With Lacer, Tools, Punch Cards and Manual	\$529.95	\$299.00
KH 820 With Lacer, Tools, Punch Cards and Manual	479.95	249.00
KR 810 Ribbing Attachment (for 820 machine)	229.95	129.50
KH 710 Push Button GENIE. With Lacemaker, Tools and Manual	269.50	169.50
KR 710 Ribber	269.50	159.50
KH 120 258 Fine Needle machine with Lacemaker, Tools and Manual	429.95	249.50
KR 120 Ribber - 258 needles	329.95	199.50
AM 3 KNITTING Cam operated Knitter with Ribbing Attachment, rebuilt like new, Tools and Manual	549.00	299.00
CN-9N JUMBO Knitter (Latest Model)	299.95	189.95
KH 800 Programmed Knitter with Lacer, Instructions and Tools	369.95	125.00
STUDIO 323 - Excellent Condition	499.00	195.00
JUKI 2400 - Excellent Condition	499.00	150.00
DUOMATIC With Stand and 4 Color Changer - Serial No. 1176160 - like new. Sold in 1978 for	1200.00	575.00

All machines are shipped freight collect. Calif. residents add Sales Tax.

KNITTING fights INFLATION! **SAVE \$134.00** **on a baby lock EA 605**

Volume purchasing combined with the strengthening of the U.S. dollar, allows us to reduce the price of the fabulous Cut-Sew Overlock - Model EA 605 to below \$300.00 for the first time in several years. The regular price of this handsome 'BABY' is \$429.00... Use it for that professional finish on all your sewing... and to assemble your knits... Take advantage of our inflation fighting price now... We cannot guarantee to repeat this LOW, LOW PRICE.



\$295

Order direct from **knitting**

1128 Crenshaw Boulevard, Los Angeles, California 90019

...it's new from Knitking
The KH-120\258
fine needle
knitter

Especially for
fine yarn...
(from crochet thread to
to sport yarn)

With the new
LACEMAKER that makes
exquisite fine lace as
well as
standard lace.

The **KH-120** has Twin Yarn
Feeders and Push Button Pattern
Selection for an unlimited
number of fancy stitches.

Ideal knitter for large people.

With 258 needles, the **KH-120** will
knit 32 inches wide when knitting 8 stitches
per inch... 200 needle machines can only
knit 25 inches wide at the same stitch gauge.

You can use your **KNITLEADER** with the **KH-120**.

There is a 258 needle **RIBBER ATTACHMENT** available.
You can actually rib with a fine yarn over as many as
516 needles for a superfine rib knit. You can also knit
tubular using 516 needles.



New! New! New! from KNITKING

intarsia pattern charts AND CHARTING ACCESSORY



Made specifically for the JUMBO Knitter, these new Charts can also be transferred to your Knitleader and reproduced with the new INTARSIA FEEDER on the KH 840...

The CHARTING ACCESSORY fits the JUMBO Knitter... It is simple and efficient to use... The plastic row Ruler is held in place with Magnetic Buttons so that you always know exactly where you are.

There are three sets of Patterns with five to a set. Every Pattern is a Pullover but you can use the wonderful selection of Intarsia Designs on any garment... Skirts, Dresses, Coats, etc... Also included in our package deal is a packet of blank Charts so that you can draw your own patterns.

SPECIAL INTRODUCTORY PRICE
FOR EVERYTHING... \$49.95

Calif. residents add Sales Tax.
Shipping costs \$2.25

knitking announces their

SEMINAR

and open house

1979



On the premises at 1128 Crenshaw Blvd., Los Angeles, Calif. 90019... Commencing Monday, October 8th and running through Saturday, the 13th. During the five weekdays the Seminar will operate from 10 a.m. until 4 p.m., and on Saturday from 10 a.m. until 1 p.m.

Admission will be FREE - Coffee and Doughnuts will be available at 9:30 a.m. daily. Plan to be with us and to meet the knitting experts at KNITKING. Classes and Lectures on all phases of machine knitting - Measuring - Charting, etc., will continue throughout every day.

1128 Crenshaw Boulevard, Los Angeles, California 90019

dk 750



dk 748



DK 744



OK 753



CK 752



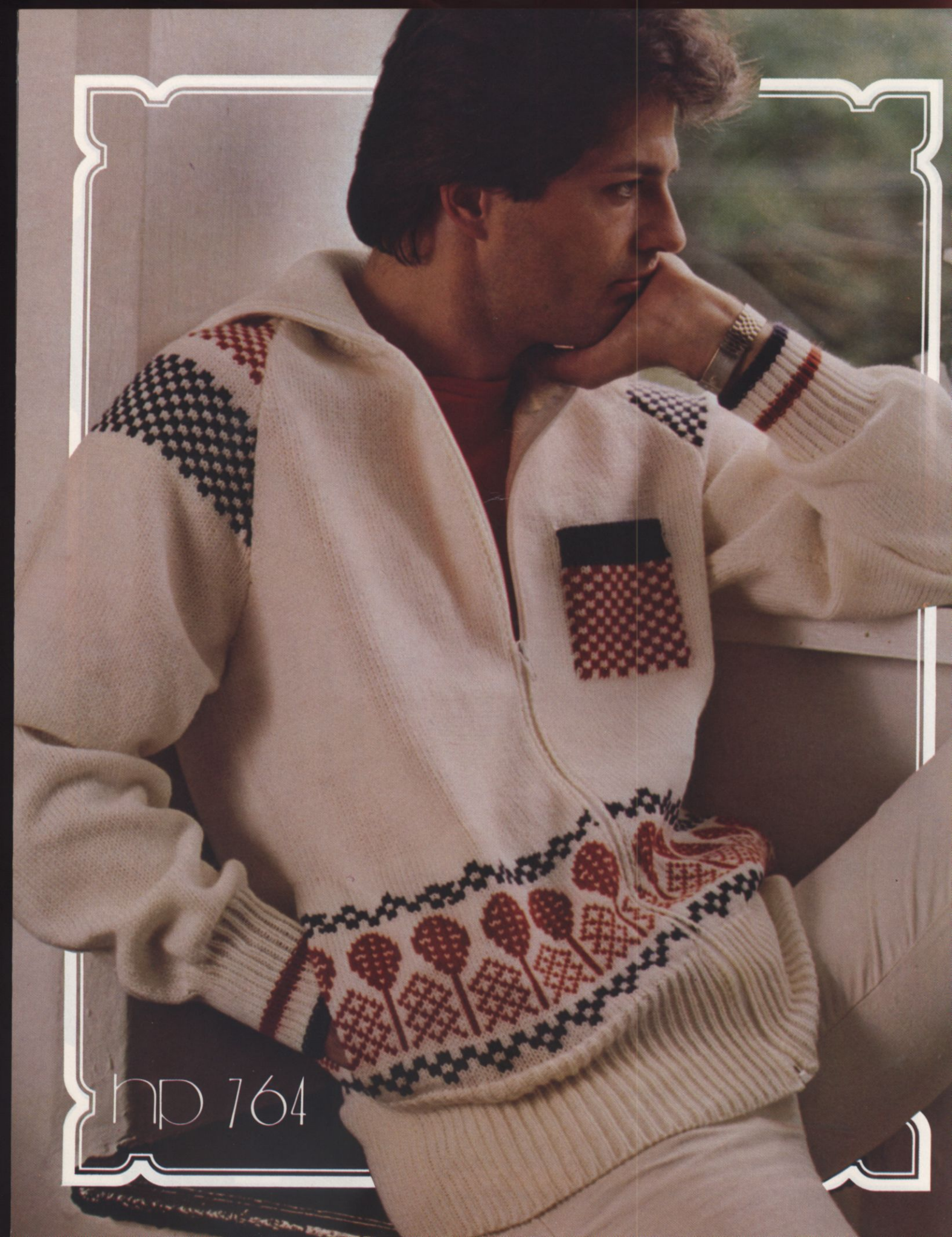

hp 764

hp 763





KK 756

KK 757

HP 755



KK 759

KK 758

np 762

