

knitking

magazine





dk 772

X 3/4-79

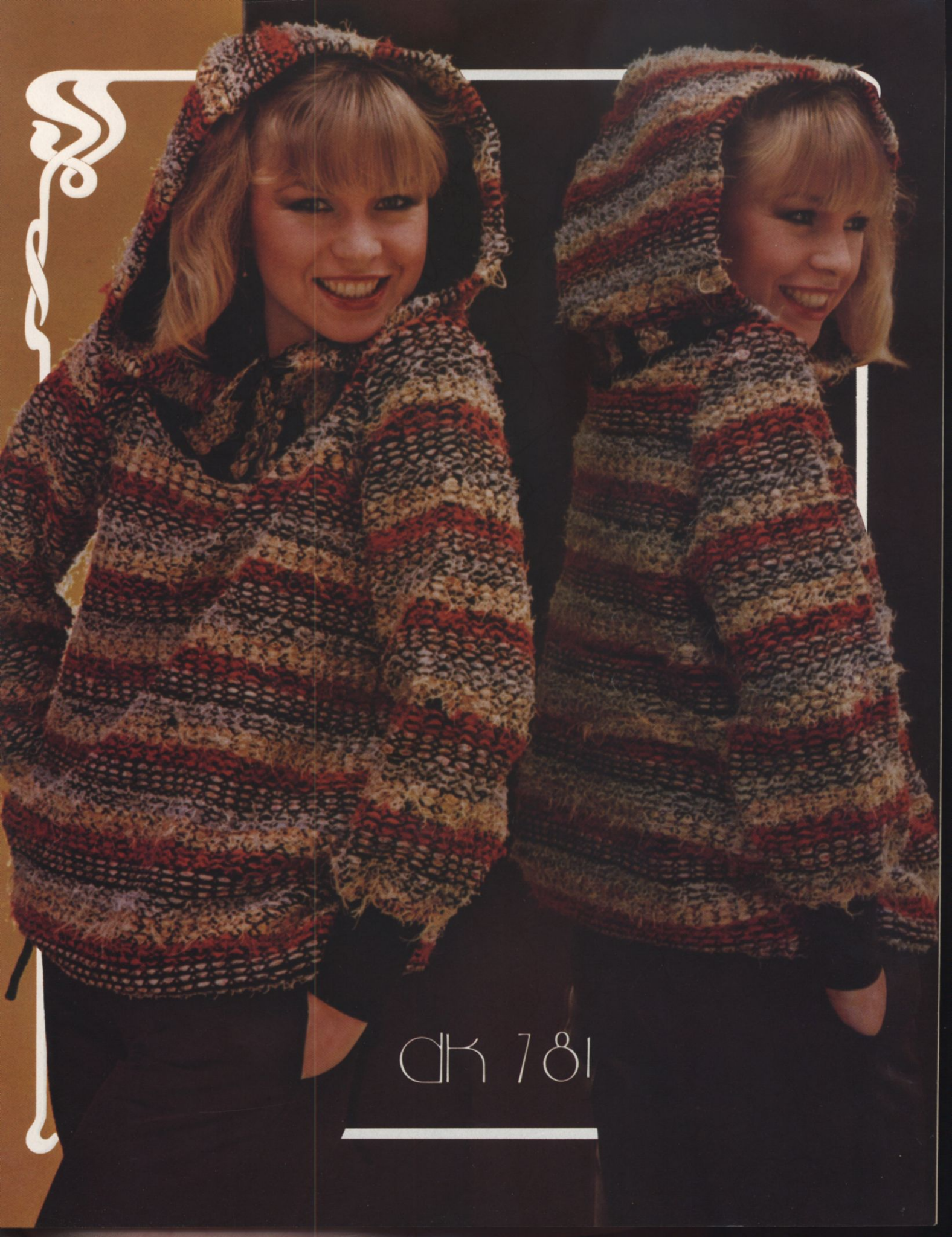

dk 781

hp 113

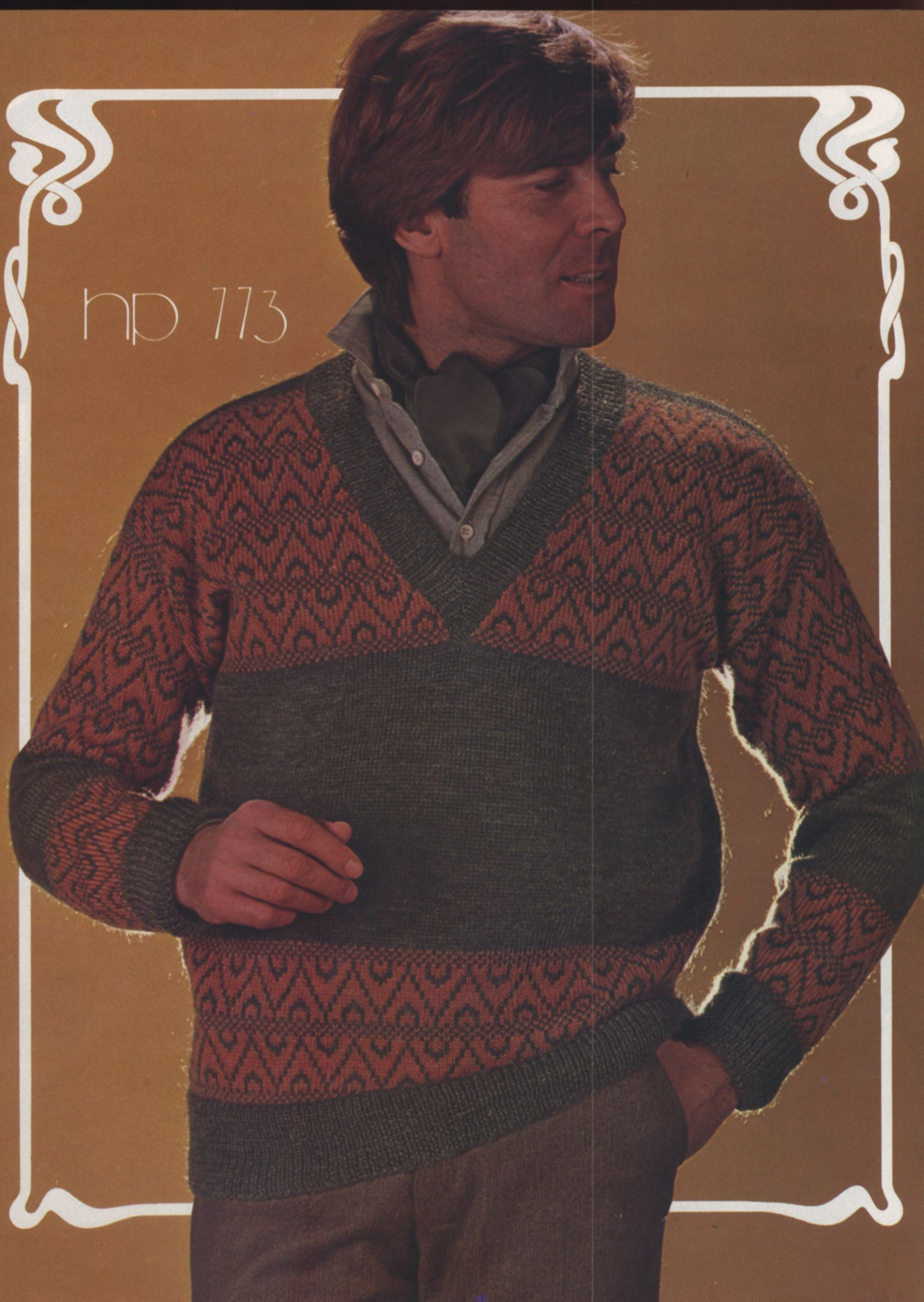

dk 775



dk 783



hp 788

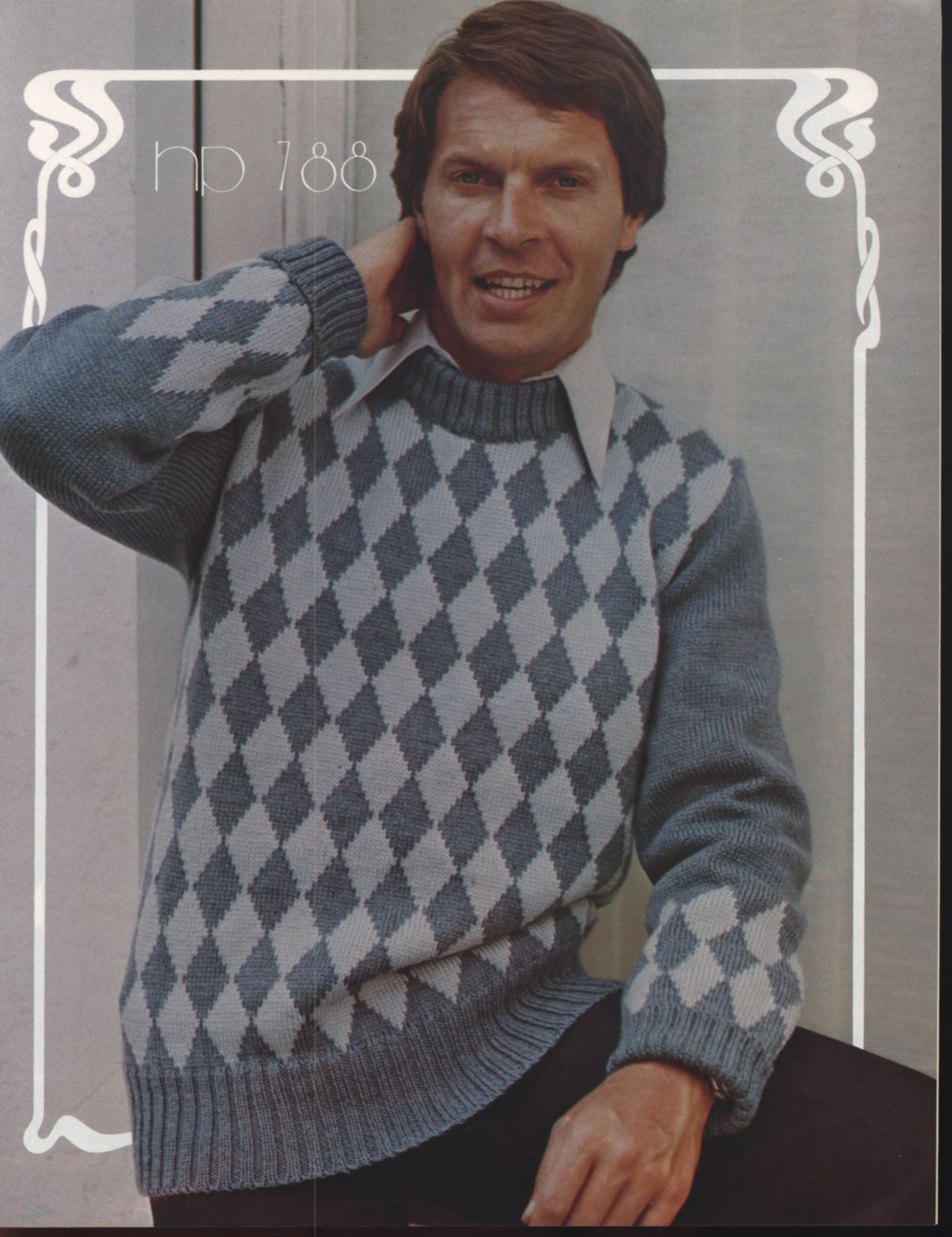

dk 777



VOLUME 15, NO. 3

knitking magazine

editorial

TABLE OF CONTENTS

PAGE NO.

KK 765 Child's Pullover	14
KK 766 Child's Pullover	15
KK 767 Child's Coat & Hood	16
DK 768 Woman's Under Ski Outfit	17
KK 769 Child's Pullover	18
KK 770 Child's Pullover	19
KK 771 Child's Pullover	20
DK 772 Woman's Jacket	21
HP 773 Man's Pullover	23
HP 774 Man's Pullover	24
DK 775 Woman's Pullover & Jacket	25
HP 776 Man's Pullover	27
DK 777 Woman's Coat	28
KK 778 Child's Pullover	29
KK 779 Teenage Pullover	31
KK 780 Woman's 2-piece Dress	33
DK 781 Woman's Pullover with Hood	34
DK 782 Woman's Pullover	35
DK 783 Woman's Jacket	37
DK 784 Woman's Pullover	38
DK 786 Woman's Pullover	39
DK 787 Woman's Hat, Scarf, Leggings & Pullover	41
HP 788 Man's Pullover	42
DK 789 Woman's Vest	43
DK 790 Woman's Dress, Pullover & Jacket	44
Snow People	46
String Apple	46
Button on Hand Towels	47

As 1979 draws to a close, we want to thank our KNITKING MAGAZINE subscribers and all of our loyal customers for their support during a very hectic, but interesting year... Our sales volume set a new record that with your continued support, we will exceed in 1980...

Our Annual Seminar was also the best ever... Our premises were bursting at the seams for the entire week... My wife Betty and I left the following week on a business trip to Japan... We had pre-arranged appointments with our various suppliers, all of whom made certain that our visit was thoroughly enjoyable...

We toured the Brother Industries complex in Nagoya - it employs over 5,000 diligent workers - and learned about some new and exciting products promised for the future... Mr. Sano, an export manager for Brother knitting machines even gave up a Sunday to personally conduct us on a tour of Kyoto, the ancient Capital of Japan.

Our friends from Corona Industries (they make our Jumbo Knitter) spent some time taking us around Nagoya where we also met with the manufacturers of the new Weaving Loom, the new XL Winder and the new Leather Punch (all featured in our Christmas Sale)...

The Juki Co., which makes our Baby Lock machines, welcomed us to Tokyo and Mr. Mano, its president, personally saw to it that we never experienced a dull moment during our stay there. We also were guided around Tokyo by an old friend, Mr. Hasegawa of Belna whose company makes our Bellinkys and with him we spent some time at the office and show-rooms of Silver Seiko, the company that manufactures Studio Knitting Machines.



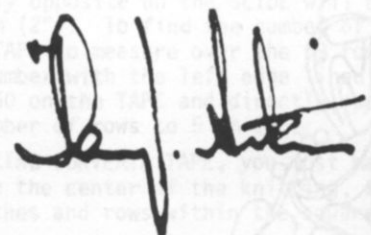













We look forward with eager anticipation to sharing with you our newly gained knowledge of products and services in the forthcoming year.











Publisher: KNITKING CORPORATION, 1128 Crenshaw Blvd., Los Angeles, Calif. 90019. Telephone: (213) 938-2079. Published bi-monthly. Subscriptions: USA — \$15.00 annually, single copies \$4.00; Canada — \$18.00; other parts of the world — \$20.00. The entire contents of KNITKING MAGAZINE are copyright and must not be reproduced in any shape or form without the express permission, in writing of the publisher. © COPYRIGHT 1979 by KNITKING CORPORATION.













Pattern Symbols

Knitting – Chart Symbols

- () Size Symbols (2nd Size)
- < > 3rd Size
- ① Color Number
-  Cast on
-  Stitch
-  Row
-  Hem
-  Bind off
-  Stockinette stitch – worn on the Knit side.
-  Stockinette stitch – worn on the Purl side.
-  Knit 1, Purl 1 Ribbing
-  Ribbing Pattern – worn on the Knit side.
-  Ribbing Pattern – worn on the Purl side.
-  Closed Dart
-  Open Dart
-  Put on a stitch holder
-  Reverse 1 section
-  On every other needle
-  Number of Rows between Shapings. Make increase (or decrease) FIRST, then knit 4 rows. For example: 3 x 1  means decrease (or increase) 1 st., knit 4 rows; decrease 1 st., knit 4 rows; decrease 1 st., knit 4 rows; decrease 1 st., knit 4 rows. All decreasing (or increasing) without row numbers as shown must be shaped on every 2nd row.

-  Increase
-  Increase 2 sts. With a transfer tool, move the sts. over the left (or right) leaving 2 empty needles at the point of increase. At the increase point, move 1 st. to the left, (or right) so that there is an empty needles on each side of a stitch. On each side of the center stitch, pick up a stitch from the row below and hang it onto the empty needle.
-  3 stitches on 1 needle. The 1st and 3rd stitch in a group of 3 has been hung on the 2nd or center needle.
-  Short Row increase or decrease; for instance on a flared skirt knitted sideways.
-  Pattern Stitch
-  Pattern Stitch – worn on the Knit side.
-  Pattern Stitch – worn on the Purl side.
-  Repeat
 - I = Front
 - II = Back
 - III = Sleeve
 - IV = Skirt Front
 - V = Skirt Back
 - VI = Collar
 - VII = Pocket
 - VIII = Band
 - IX = Belt
 - X = Cuff
 - XI = Pants Front
 - XII = Pants Back

Finishing – Chart Symbols

-  Match numbers on section for assembling.
 -  Ease
 -  Fold Line
 -  Turn to the wrong side and hem.
- ### Stitch Symbols
-  Needles in holding position
 -  Needles back into working position.
 -  Empty needle (leave in working position)
 -  Needle not used (in the out of work position).
 -  Two stitches on 1 needle, either transferred from the right side or the left side, then put into holding position.
 -  Needle holding 2 stitches. Stitch has been transferred from the RIGHT.
 -  Needle holding 2 stitches. Stitch has been transferred from the LEFT.
 -  Center of garment section



General Instructions

HOW TO READ THE CHARTS AND INSTRUCTIONS

There are 3 sizes given for each Pattern in KNITTING MAGAZINE. Above each Chart for the different sizes, you will see that the first and smaller sizes might be shown as 8/10, the second size as [12/14] and the third as [16/18]. Check the measurements at the bustline and hips on the Charts to be certain that you will knit the correct size, remembering these are ACTUAL measurements of the completed section and that there must be a bigger allowance at the bustline and hipline for a Jacket or a Coat than there would be for a fitted dress or a fitted blouse or pullover. The question in your mind should be "How do I want this garment to fit...?"

When you have chosen the size you need, you can follow the Charts as shown. You will notice that where the shapings are the same FOR ALL SIZES, only 1 set of shapings will be shown on the first Chart and if you are knitting the 2nd or 3rd size, you simply follow the shapings as given for the first size. If the shapings are different, this will be shown on the Charts and you should follow them as given.

On the Charts, increases and decreases will be shown as follows

5x1

6 The number in the box means number of ROWS between the shapings, while the 5x1 above the box means - 1 st. 5x... so you will increase or decrease 1 st. every 6th row 5x.

ARMHOLE SHAPINGS - NECK SHAPINGS - SHOULDER SHAPINGS - are made on every 2nd row UNLESS there is a number in a box along side or below the shapings. The rule is... where there is no box with a number, the shaping is made on every 2nd row.

THE PRINTED INSTRUCTIONS

You can follow the printed instructions or use them in combination with the Charts. Where there is any question in the printed instructions, you have the Charts to show you how the section will look.

The 3 sizes, with the different amounts of cast on stitches and the different shapings will look like this...

Cast on 124 [136] [148] sts. You will

Cast on 124 sts. for the first size.

Cast on 136 sts. for the 2nd size.

Cast on 148 sts. for the 3rd size.

The important thing to remember is that you MUST READ AHEAD so that you KNOW what to do for the size you are knitting. Sometimes where the number of stitches are the same but the number of times different, you will find shapings like this... 3 sts. 1x (2x) [3x], 2 sts. 1x (2x) [3x], 1 st. 3x (4x) [5x]. As you see, you MUST read ahead in order to follow the instructions as given for YOUR SIZE. The rows will be different for the different sizes in some cases... Shoulder and Neck shapings usually are worked at the SAME TIME for the back section - so watch for the words AT THE SAME TIME.

HOLDING STITCHES ON THE LEFT SIDE WHILE SHAPING THE RIGHT SIDE

When knitting a section of garment in stockinette stitch, it is easy to hold the stitches on the left side while knitting the right half, but when knitting a Pattern Stitch such as a Norwegian Design, a Holding Position Design, Weaving, etc., you should use the following method. For the NECK SHAPING, we tell you to bind off the center sts., put the needles on the left into holding position and complete the right half first... so with a strand of contrast yarn, knit ALL of the left side stitches manually by hand, pulling each stitch back against the needle bed to the OUT OF WORK position. When the right side is completed, carefully pull the stitches held on contrast, forward into working position and as you do so, undo the contrast yarn, line up the needles (KNITTING AM 3 machine owners, put the stitches under the sinkers) and complete the left half.

If you own a Japanese machine, you may find that when knitting the right half with the left side held in this way, the sinker plate will mark the left side while you are knitting the right half. To prevent this marking, you can tape a piece of paper over the knitting, underneath the sinkers, or if you own a Reversing Bar, you can hang this onto the Sinkers while you are knitting the right half. When hanging the Reversing Bar, be sure the eyes of the bar go BETWEEN the Sinker Posts on the upper part of the bar so that the tips of the bar only - show above the needle bed.

FULL FASHION DECREASING OR INCREASING

For Stockinette stitch, always use the Full Fashion method for increasing or decreasing.

TO DECREASE: Hang the 3rd stitch onto the 2nd stitch then move the stitches in to fill the empty needle.

TO INCREASE: Move the 2 end stitches 1 needle outward, then pick up the 3rd stitch from the row below and hang it onto the empty needle.

FINISHING: Block all sections. For PULLOVERS, JACKETS, and DRESSES: Join front to back at sides and shoulders. Sew sleeves together and set in. Hem lower edge and sleeve edges if needed. For a double neckband or armhole band, sew 1 edge to the inside and 1 to the outside of neck or armhole. For a single ribbed band, sew 1 edge to the outside of neck or armhole edge. For a cardigan or jacket with buttonholes, finish buttonholes and sew on buttons.

PANTS: Join front to back at sides. Sew inside leg seams, then join center front and back. Make hem at waistline and insert elastic. Hem lower edge of pants legs.

THE SAMPLE SWATCH

Before you begin to knit any garment, you will need to knit a sample piece using the yarn you have chosen for your garment, so that you can check the stitch and row gauge which must measure the correct number of stitches and rows in 5 cm (2 inches).

For each Pattern in KNITTING MAGAZINE, we give you 3 tension numbers to work from and if you use the specified yarn for the garment, you should be able to get the correct stitch and row gauge using one of these numbers. Here is a very easy way to make your sample swatch and count the stitches and rows without actually counting, by using our KNITTING Converta Tape.

Supposing the Tension Numbers for the Stitch and Row Gauge are given as 5 to 7. Set the Tension Dial to the first number which is 5. With contrast waste yarn, and using the quick cast on method, cast on 60 stitches and knit 10 rows. Change to garment yarn and turn the Row Counter to 0. Knit 30 rows. Counting from each end, knit the 10th stitch on each side by hand with a small piece of contrast yarn. Leave the needles in working position and knit 30 rows (Row 60), then knit 4 rows with contrast waste yarn. Turn the Row Counter to 0 and the Tension Dial to 6 and with garment yarn, knit 30 rows. Mark the 10th stitch on each side as you did before, knit 30 rows, then 4 rows with contrast waste yarn. Turn the Row Counter to 0 and with Tension 7, repeat the above once more, ending with 10 rows of contrast waste yarn. Remove the work from the machine by passing the Slide across the needles without yarn (sometimes called 'dropping').

Pull and stretch the sample piece both lengthwise and diagonally from corner to corner, then lengthwise again. Do not count the stitches and rows immediately, but allow the sample to rest for several hours or even over night. This will allow the stitches and rows to return to their basic form.

When your sample has rested and you are ready to count the stitches and rows, the KNITTING CONVERTA TAPE will do the counting for you without any counting on your part. Use the Tape as follows:

Measure the stitches with the TAPE, BETWEEN the 40 stitches marked with contrast waste yarn. Push the SLIDE so that the LEFT EDGE lines up to this exact measurement. Now look down along side the SLIDE and find the number 40 on the TAPE. The number directly opposite on the SLIDE will be your Stitch Gauge to 5 cm (2"). To find the number of rows in 5 cm (2"), place the TAPE to measure over the 60 rows, push the SLIDE to this number with the left edge lined up, the look for the number 60 on the TAPE and directly opposite this will be the number of rows to 5 cm (2")

If you do not own a KNITTING CONVERTA TAPE, you must mark a 5 cm (2 inch) square in the center of the knitting, then count the number of stitches and rows within the square.

KK 765

CHILD'S PULLOVER

SIZES: 8 (10) [12]
YARN: Amore
GRAMS:
 color 1 250 250 300
 color 2 150 150 150
 color 3 Small amount of Red for Pocket.
TENSION: 7 to 9
GAUGE: 14 sts. 17 rows = 5 cm (2")



Stockinette stitch with a Cable on side front sections only.
 Bands are K1, P1 Ribbing.

FINISHING: See General Instructions. Attach Pocket on Center Front 1 1/2" up from Ribbing. Sew side panel to front and back with cable on front. Set in sleeves.

SIDE FRONT & BACK - Reverse the side for the Cables on second piece.

Cast on 40 sts. with color 2 and work the Cable Pattern as follows: K2, P2, K6, P2, K 26. After every 8th row, cross the 6 Knit sts. and after every 20 rows, drop the sts. ON EACH SIDE of cable and latch them up.
 After Row 82 (86) [90], divide in the center, put the needles on the left into holding position and complete the right side first.
 *ON ARM SIDE, bind off 3 sts. 1x, 2 sts. 4x, 1 st. 1x.
 Knit to Row 140 (148) [152] then bind-off the remaining sts.
 Bring the needles on the left into working position, knit 1 row to the left side, turn the Row Counter back to 140 (148) [152] and complete the left side. Follow the instructions from *.

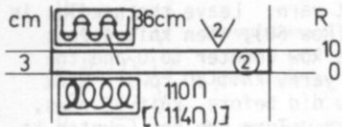
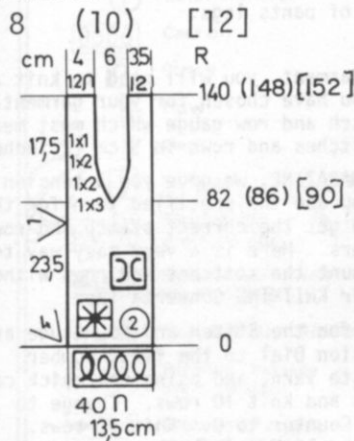

NECKBAND:

Cast on 110 (114) [114] sts. with color 2 and work 10 rows Ribbing. Bind off.

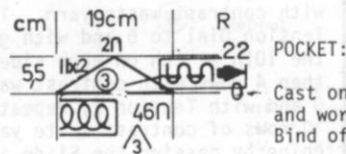

POCKET:

Cast on 46 sts. with color 3 and work 40 rows Stockinette stitch. Bind off.

BACK: II

Cast on 92 (98) [102] sts. with color 2 and work 22 rows Ribbing. ON EACH SIDE, bind off 14 (15) [15] sts (or you can remove them onto a stitch holder). Continue in Stockinette stitch with color 1. Knit to Row 162 (170) [174]. ON EACH SIDE, bind off 12 (14) [15] sts. for shoulder then bind off (or put on stitch holder) the 40 (40) [42] sts. for neck.

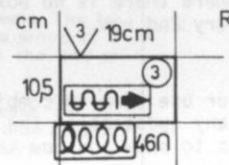

POCKET TAB:

Cast on 46 sts. with color 3 and work Stockinette stitch. ON EACH SIDE, bind off 2 sts. 11x. After Row 22, bind off the remaining 2 sts.

FRONT: I

Work the front the same as the back to Row 144 (150) [154]. Put half the sts. on the left into holding position and complete the right side first.
 *ON NECK SIDE, bind off 5 sts. 1x, 3 sts. 1x, 2 sts. 3x, 1 st. 6x. (Same as first size). [5 sts. 1x, 3 sts. 1x, 2 sts. 4x, 1 st. 5x]. Bind off the remaining 12 (14) [15] sts. for shoulder. Bring the needles on the left into working position, knit 1 row to the left side, turn the Row Counter back to 144 (150) [154] and complete the left half. Follow the instruction from *.

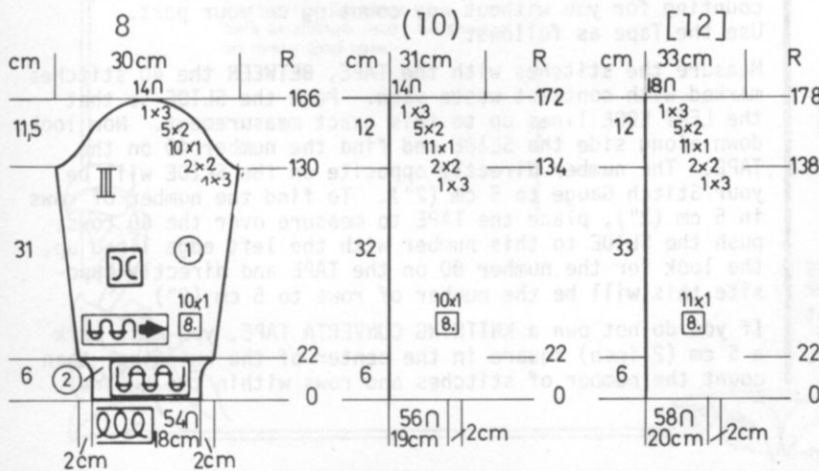
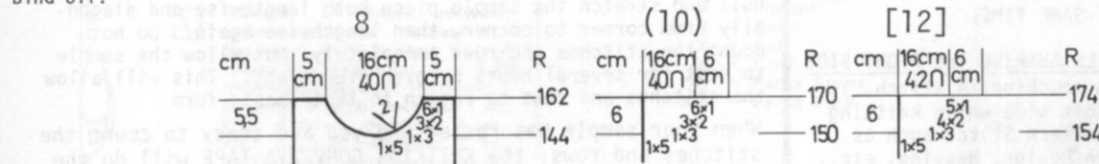

SLEEVES: III

Cast on 54 (56) [58] sts. with color 2 and work 22 rows Ribbing. Continue in Stockinette stitch with color 1. ON EACH SIDE, increase 1 st. every 8th row 10x (10x) [11x]. After Row 130 (134) [138], SHAPE CAP: ON EACH SIDE, bind off 3 sts. 1x, 2 sts. 2x, 1 st. 10x, 2 sts. 5x, 3 sts. 1x. (3 sts. 1x, 2 sts. 2x, 1 st. 11x, 2 sts. 5x, 3 sts. 1x). [3 sts. 1x, 2 sts. 2x, 1 st. 11x, 2 sts. 5x, 3 sts. 1x]. After Row 166 (172) [178], bind off the remaining sts.

766



CHILD'S PULLOVER

SIZES: 4 (6) [8]
 YARN: Crocus
 GRAMS:
 color 1 250 250 300
 color 2 50 50 50
 color 3 50 50 50
 color 4 50 50 50
 TENSION: 6 to 8
 GAUGE: 12 1/2 sts. 17 rows = 5 cm (2")

Stockinette stitch with a Norwegian Design on the front section. HAND FEED the Design. Use Bobbins for each color. Be sure to twist the yarns when changing colors to avoid a hole. Follow the Line Drawing after Row 36 on the front section. K1, P1 for the bands.

FINISHING: See General Instructions. For the fruit on tree, use 2 strands of color 3 and 1 of color 1 and tie into marked stitches. For the Neckband, sew up 1 shoulder then pick up the stitches around neck.

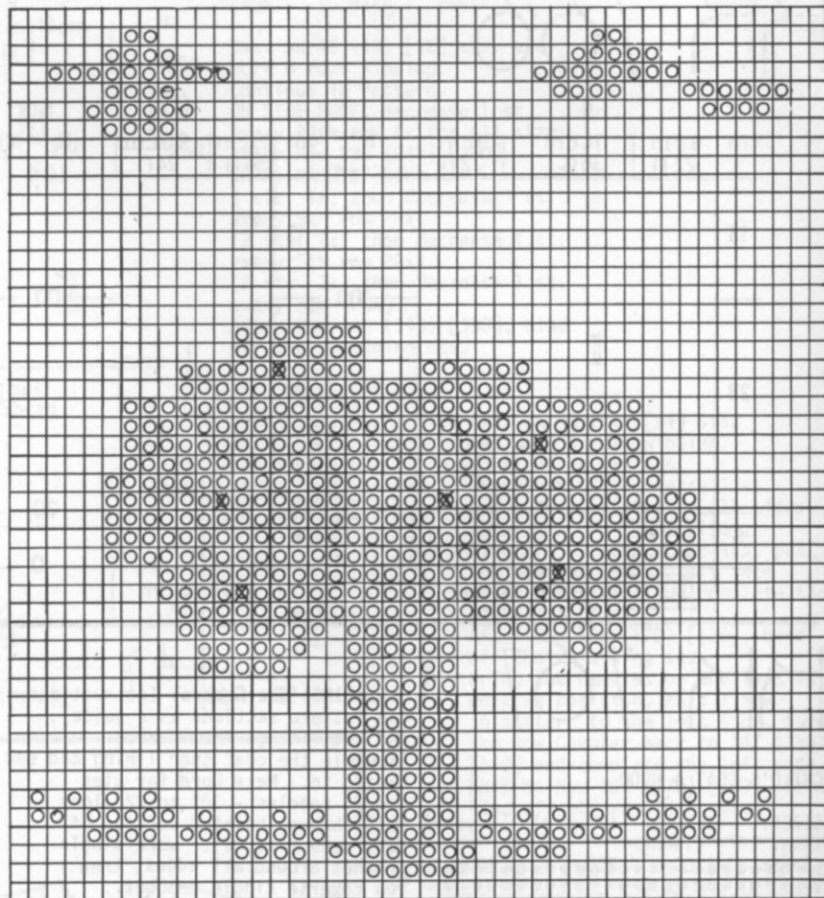

SLEEVES: III

Cast on 40 (42) [46] sts. with color 2 and work 20 rows Ribbing. Continue in Stockinette stitch with color 1.
 ON EACH SIDE, increase 1 st. every 5th row 13x for all sizes.
 After Row 92 (96) [98], bind off.

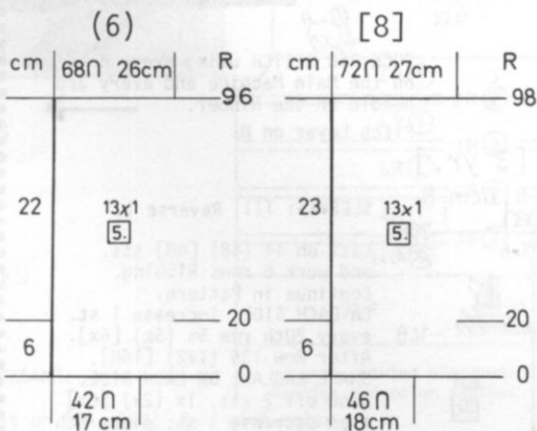
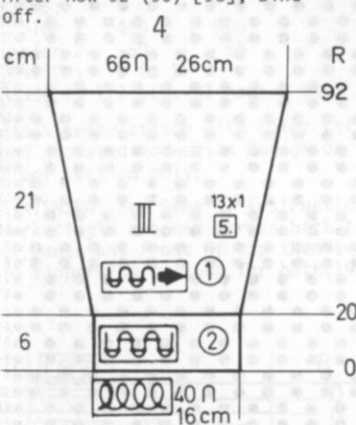

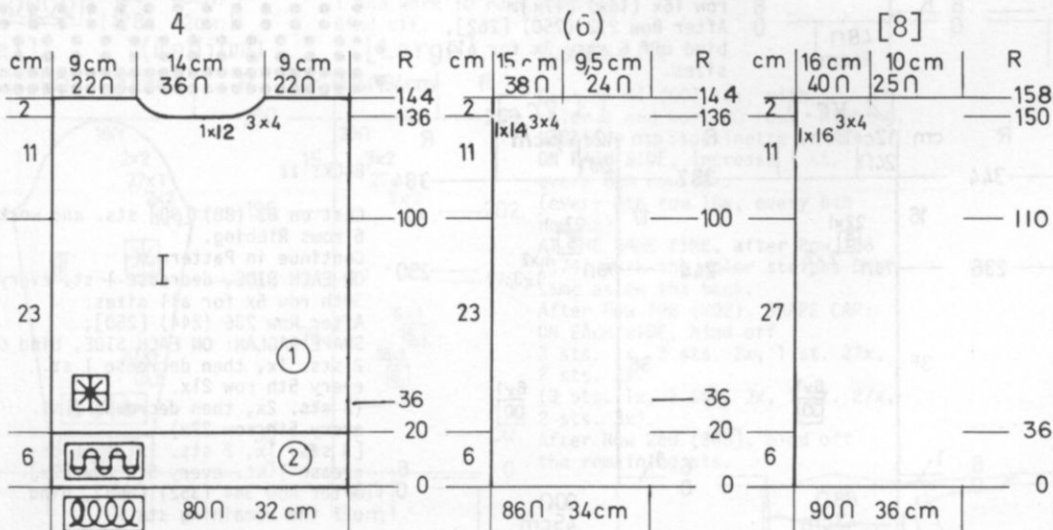

FRONT: I

Cast on 80 (86) [90] sts. with color 2 and work 20 rows Ribbing. Continue in Stockinette stitch with color 1.
 Knit to Row 36.
 Begin the isolated Design following the line Drawing. (See information above the Finishing Instructions). Center the lower line on the front of garment and add as many extra color 4 patterns across the lower front as is needed for your size (See Picture and use Line Drawing as guide).
 When Design is completed, continue in Stockinette stitch with color 1 and mark Row 100 (100) [110] for setting in the sleeves.
 After Row 136 (136) [150], bind off (or remove onto waste yarn) the center 12 (14) [16] sts. for neck, put the needles on the left into holding position and complete the right side first.
 *ON NECK SIDE, bind off 4 sts. 3x for all sizes.
 After Row 144 (144) [158], bind off (or remove onto waste yarn) the remaining 22 (24) [25] sts. Bring the needles on the left into working position, turn the Row Counter back to 136 (136) [150] and complete the left half. Follow the instructions from *.



KK 700

4				(6)				[8]					
cm	9cm	14cm	9cm	R	cm	15cm	9.5cm	R	cm	16cm	10cm	R	
	22n	36n	22n	14.4		38n	24n	14.4		40n	25n	15.8	
13					13				13				
				100				100				110	
23					23				27				
				20				20				20	
6				0	6			0	6			0	
													
		80n	32cm			86n	34cm			90n	36cm		

NECKBAND:

Sew 1 shoulder seam then pick up the sts. around the neckline and work 10 rows Ribbing with color 1. Bind off.

BACK: II

Cast on 80 (86) [90] sts. with color 2 and work 20 rows Ribbing. Continue in Stockinette stitch with color 1.
 Knit to Row 100 (100) [110]. Mark each side with a bit of contrast waste yarn for setting in sleeves. Knit to Row 144 (144) [158]. Bind off 22 (24) [25] sts. ON EACH SIDE for shoulder then remove the 36 (34) [40] sts. for neck onto contrast waste yarn. OR you can remove each shoulder onto different color waste yarn and put the shoulders together on the machine later.

KK 767

CHILD'S COAT & HOOD

SIZES: 1 year (2 year) [3 year]
 YARN: Vienna
 GRAMS: 250 250 [300]
 TENSION: 4 to 6
 GAUGE: 10 sts. 24 rows = 5 cm (2")

FINISHING: See General Instructions. Use Pattern sections as a guide and cut linings from fabric. Assemble the coat then lining and sew lining in. Make Cord for ties over 5 needles - 20" to 22" long. Pull through knitted section of coat (see Picture). Work single crochet around all edges, then 1 row reverse single crochet..



A Ribbing Pattern. 840/830 machines use Card No.2. Bands are K1, P1 Ribbing.

TUCK-RIB STITCH using every needle on the Main Machine and every 3rd needle on the Ribber. Pitch Lever on H.

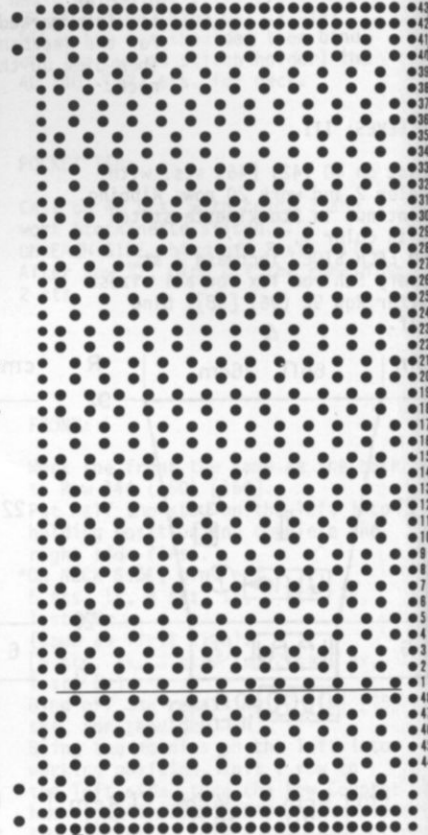

1 yr.				(2 yr.)				[3 yr.]				
cm	9cm	8cm	9cm	R	cm	8	10cm	R	cm	8	10cm	R
		18n		238		18n		256		18n		268
		3x6		232		3x6		250		3x6		262
15					16				17			
				136				14.2				14.8
19					20				21			
				6				6				6
				0				0				0
		44n	23cm			48n	24cm			48n	24cm	

SLEEVES: III Reverse 1.

Cast on 44 (48) [48] sts. and work 6 rows Ribbing. Continue in Pattern. ON EACH SIDE, increase 1 st. every 20th row 5x (5x) [6x]. After Row 136 (142) [148], SHAPE RAGLAN: ON EACH SIDE, bind off 2 sts. 1x (2x) [2x] then decrease 1 st. every 6th row 16x (16x) [17x]. After Row 232 (250) [262], bind off 6 sts. 3x for all sizes.

1 yr.				[2 yr.]				[3 yr.]				
cm	11.5cm	12cm	11.5cm	R	cm	12c	13cm	R	cm	12c	13.5cm	R
		24n		344		24n		352		24n		364
15					16				17			
				236				244				250
34					36				36			
				6				6				6
				0				0				0
		82n	40cm			88n	43cm			90n	45cm	

BACK: II

Cast on 82 (88) [90] sts. and work 6 rows Ribbing. Continue in Pattern. ON EACH SIDE, decrease 1 st. every 30th row 6x for all sizes. After Row 236 (244) [250], SHAPE RAGLAN: ON EACH SIDE, bind off 2 sts. 1x, then decrease 1 st. every 5th row 21x. (2 sts. 2x, then decrease 1 st. every 5th row 22x). [3 sts. 1x, 2 sts. 1x, then decrease 1 st. every 5th row 22x]. After Row 344 (352) [364], bind off the remaining sts.

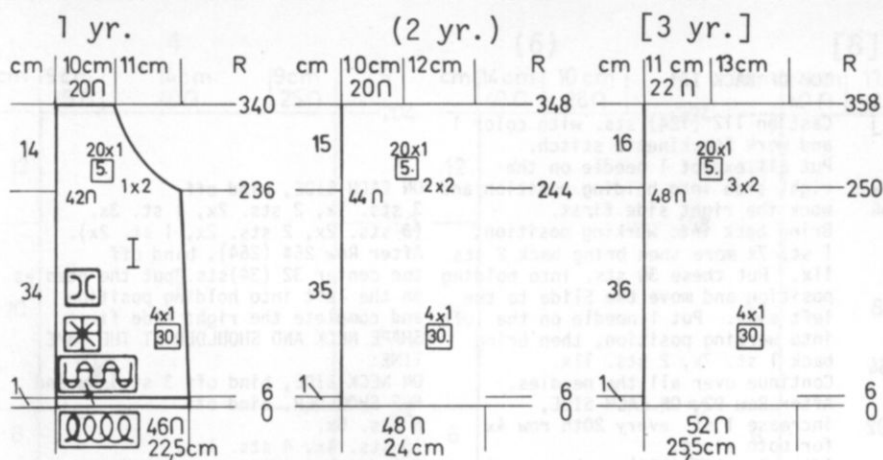

FRONT: I Make 1, reverse 1.
 Cast on 46 (48) [52] sts. and work 6 rows Ribbing. Continue in Pattern.
 ON SIDE EDGE, decrease 1 st. every 30th row 4x for all sizes.
 After Row 236 (244) [250], SHAPE RAGLAN: BIND OFF 2 sts. 1x, then decrease 1 st. every 5th row 20x.
 (2 sts. 2x, then decrease 1 st. every 5th row 20x).
 [2 sts. 3x, then decrease 1 st. every 5th row 20x].
 After Row 340 (348) [358], bind off the remaining sts.

HOOD:
 Cast on 90 (90) [94] sts. and work 6 rows Ribbing. Continue in Pattern.
 ON EACH SIDE, decrease 1 st. every 44th row 3x for all sizes.
 After Row 142 (150) [150], bind off the center 12 sts, put the needles on the left into holding position and complete the right side first.
 After Row 162 (170) [170], bind off the remaining sts.
 Bring the needles on the left into working position, knit 1 row in pattern to the left side, turn the Row Counter back to 142 (150) [150] and complete the left side. Knit to Row 162 (170) [170] then bind off the remaining sts.

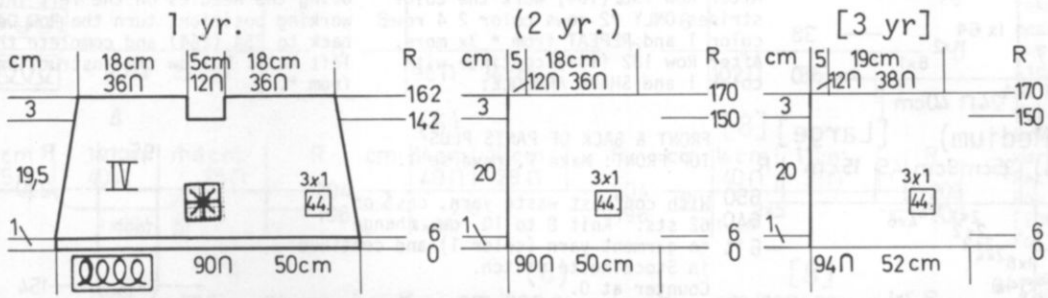

dk 768



WOMAN'S UNDER SKI OUTFIT

SIZES: SMALL MEDIUM
 YARN: Micaela
 GRAMS: color 1 450 500
 color 2 50 50
 TENSION: 5 to 7
 GAUGE: 15 1/2 sts. 22 rows = 5 cm (2")

Stockinette stitch with color stripes and isolated Norwegian Design on the front section only.

FINISHING: See General Instructions. Work single crochet across back rap of pants and front of top then sew in zippers (50 cm long for both (19 3/4"))

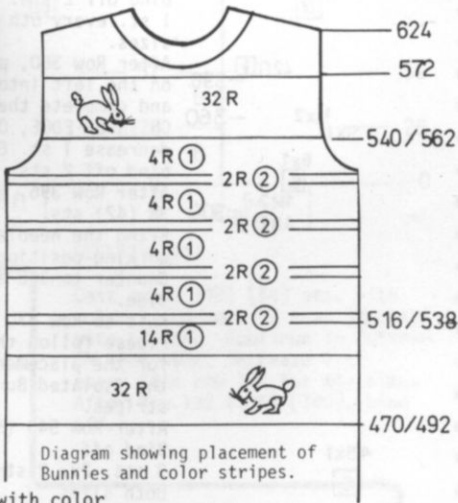
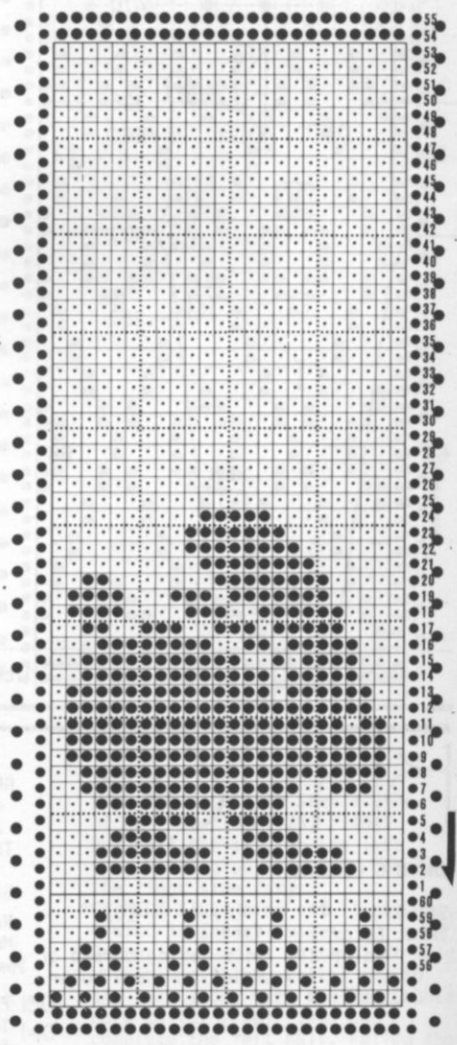
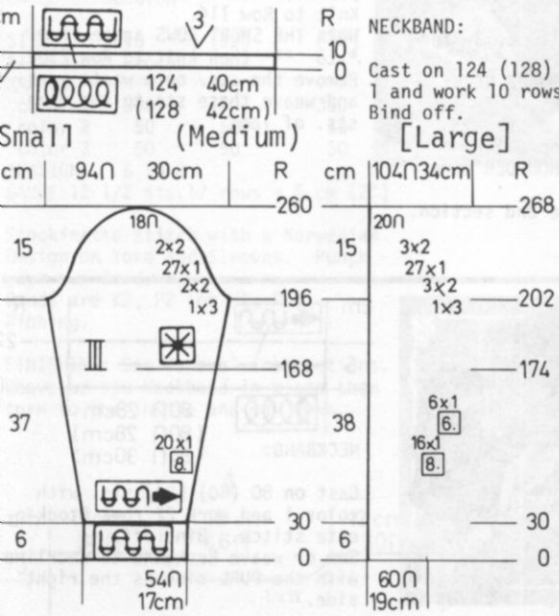

Diagram showing placement of Bunnies and color stripes.

NECKBAND:
 Cast on 124 (128) sts. with color 1 and work 10 rows Ribbing. Bind off.

SLEEVES: III

Cast on 54 (60) sts. with color 1 and work 30 rows Ribbing. Continue in Stockinette stitch. ON EACH SIDE, increase 1 st. every 8th row 20x. (every 8th row 16x, every 6th row 6x).
 AT THE SAME TIME, after Row 168 (174) work the color stripes ONLY same as on the back.
 After Row 196 (202), SHAPE CAP: ON EACH SIDE, bind off 3 sts. 1x, 2 sts. 2x, 1 st. 27x, 2 sts. 2x.
 (3 sts. 1x, 2 sts. 3x, 1 st. 27x, 2 sts. 3x).
 After Row 260 (268), bind off the remaining sts.



DK 768

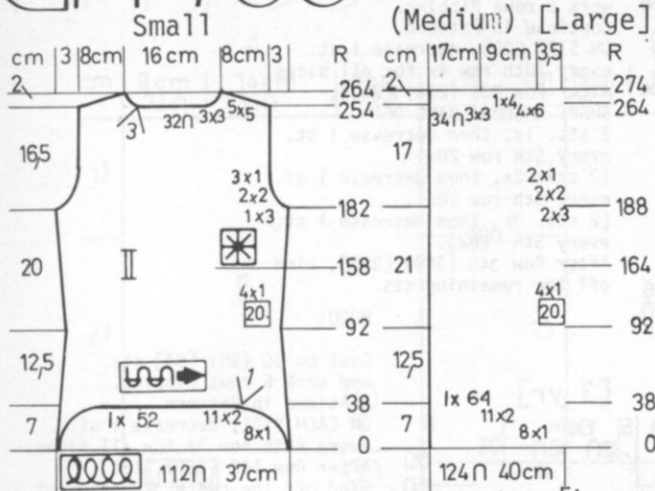

TOP OF BACK II

Cast on 112 (124) sts. with color 1 and work Stockinette stitch. Put all except 1 needle on the right side into holding position and work the right side first. Bring back into working position, 1 st. 7x more then bring back 2 sts. 11x. Put these 30 sts. into holding position and move the Slide to the left side. Put 1 needle on the left into working position, then bring back 1 st. 7x, 2 sts. 11x. Continue over all the needles. After Row 92, ON EACH SIDE, increase 1 st. every 20th row 4x for both sizes. After Row 158 (164) work the color stripes ONLY *2 rows color 2 4 rows color 1 and REPEAT from * 3x more. After Row 182 (188) continue with color 1 and SHAPE ARMHOLE:

ON EACH SIDE, bind off 3 sts. 1x, 2 sts. 2x, 1 st. 3x. (3 sts. 2x, 2 sts. 2x, 1 st. 2x). After Row 254 (264), bind off the center 32 (34)sts. put the needles on the left into holding position and complete the right side first. *SHAPE NECK AND SHOULDER AT THE SAME TIME: ON NECK SIDE, bind off 3 sts. 3x and FOR SHOULDER, bind off 5 sts. 5x. (6 sts. 4x, 4 sts. 1x). Bring the needles on the left into working position, turn the Row Counter back to 254 (264) and complete the left half. Follow the instructions from *.

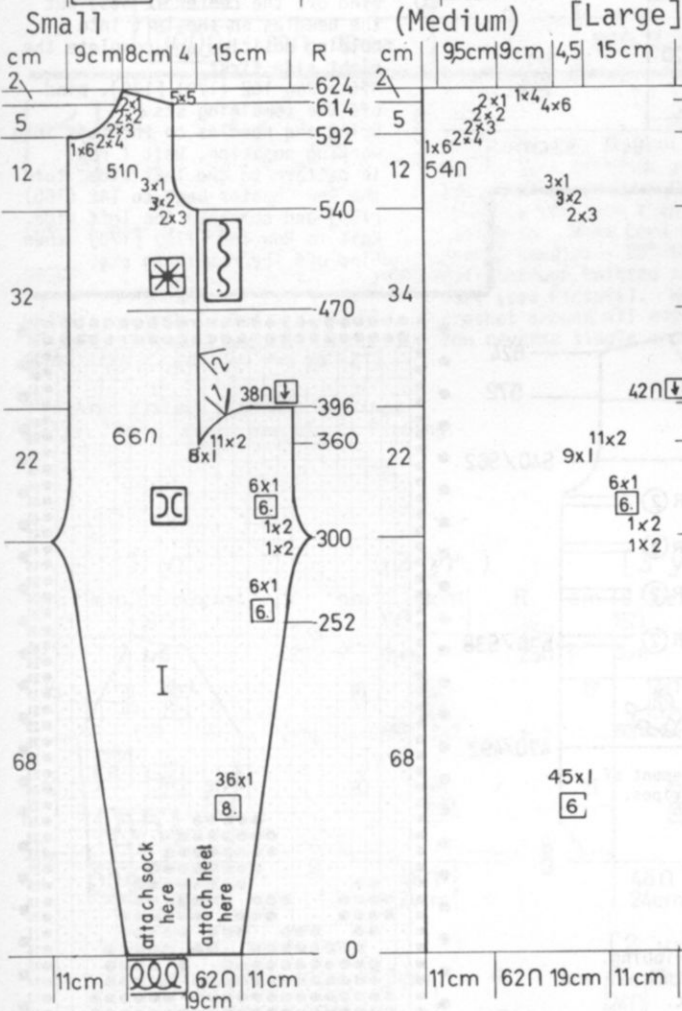

FRONT & BACK OF PANTS PLUS TOP FRONT: Make 1, reverse 1.

With contrast waste yarn, cast on 62 sts. Knit 8 to 10 row, change to garment yarn (color 1) and continue in Stockinette stitch. Counter at 0. ON EACH SIDE, increase 1 st. every 8th row 36x, every 6th row 6x, then cast on 2 sts. 1x. (every 6th row 45x, then cast on 2 sts. 1x). After Row 300, ON EACH SIDE, bind off 2 sts. 1x, then decrease 1 st. every 6th row 6x for both sizes. After Row 360, put 66 (69) sts. on the left into holding position and complete the right side first. ON INNER EDGE, ON EVERY 2nd row, decrease 1 st. 8x (9x) then bind off 2 sts. 11x. After Row 396, bind off the remaining 38 (42) sts. Bring the needles on the left into working position, Turn the Row Counter to 360 and work the left side. Knit to Row 470 (492). Please follow the Line Drawing for the placement and rows for the isolated Bunny and the color stripes. After Row 540 (562), SHAPE ARMHOLE: Bind off 3 sts. 2x, 2 sts. 3x, 1 st. 3x for both sizes. After Row 591 (613), SHAPE NECK: Bind off for both sizes, 6 sts. 1x, 4 sts. 2x, 3 sts. 2x, 2 sts. 2x, 1 st. 2x and after Row 614 (640) SHAPE SHOULDER same as the back. Be sure to REVERSE the 2nd section.

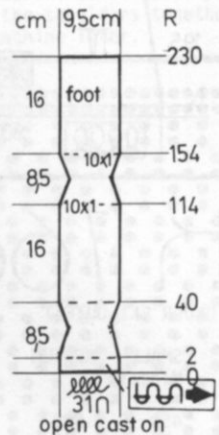

FOOT SECTIONS

Hang back half of bottom of garment (held on waste yarn) on the machine. Put counter at 0 and work Stockinette stitch with color 1. WORK SHORT ROWS: *ON OPPOSITE SIDE OF SLIDE, put into hiding position 1 st. 10x ON EACH SIDE, then ON OPPOSITE SIDE OF SLIDE, bring 1 st. back into working position 10x ON EACH SIDE.** Knit to Row 114. WORK THE SHORT ROWS again from * to ** then knit to Row 230. Remove the sts. onto waste yarn and weave these sts. to the open sts. of leg.

DK 769

CHILD'S PULLOVER

SIZES: 4 (6) [8]

YARN: Color 1 = Vienna
Color 2 = Silk Sewing thread or Monofil - same color.

GRAMS: color 1 200 200 250
color 2 1 spool for all sizes
TENSION: Pat. 4 to 6
Bands 3 to 5
GAUGE: 14 sts. 22 rows = 5 cm (2")

Norwegian Technique using thread or Monofil. Studio machine owners can work Punch Lace. Punch your own Card.

FINISHING: See General Instructions. Turn bands to the knit side and sew in place.

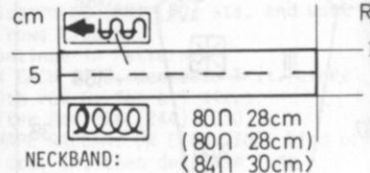

Cast on 80 (80) [84] sts. with color 1 and work 22 rows Stockinette stitch. Bind off. Sew or weave Neckband to neckline with the PURL side as the right side.

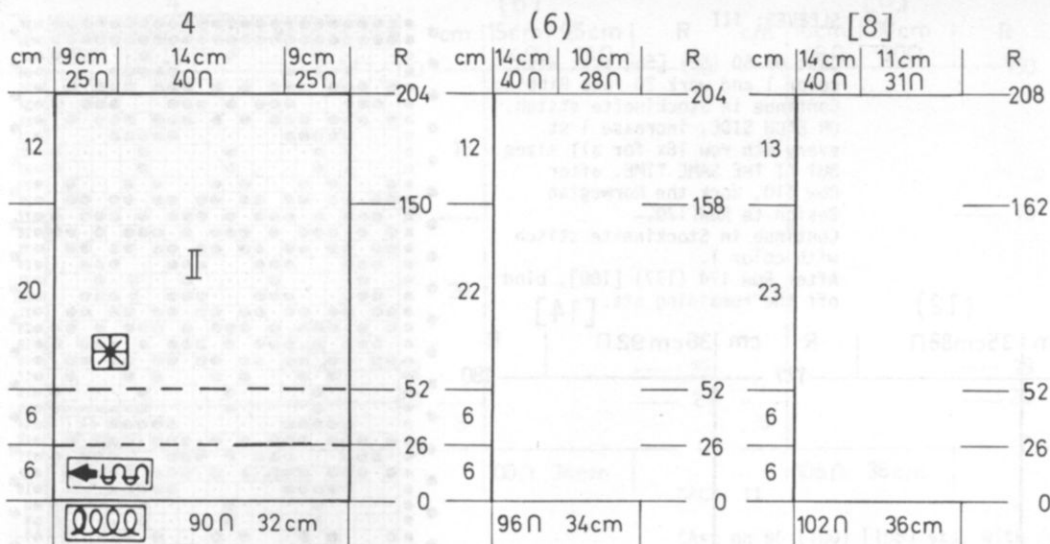

BACK: II

Cast on 90 (96) [102] sts. with color 1 and work 52 rows Stockinette stitch. Continue in Pattern. Knit to Row 150 (158) [162]. Mark each side with bit of contrast yarn for setting in sleeves. Knit to Row 204 (204) [208]. ON EACH SIDE, bind off (or remove onto waste yarn) 25 (28) [31] sts. for shoulders then remove or bind off the 40 neck sts.

FRONT: I

Work the front the same as the back to Row 196 (200) [200]. Bind off the center 20 sts. (or remove onto waste yarn) put the needles on the left into holding position and complete the right side first.

*ON NECK SIDE, bind off 5 sts. 2x for all sizes.

Bring the needles on the left into working position, knit 1 row in Pattern to the left side, turn the Row Counter back to 196 (196) [200] and complete the left half. Follow the instructions from *.

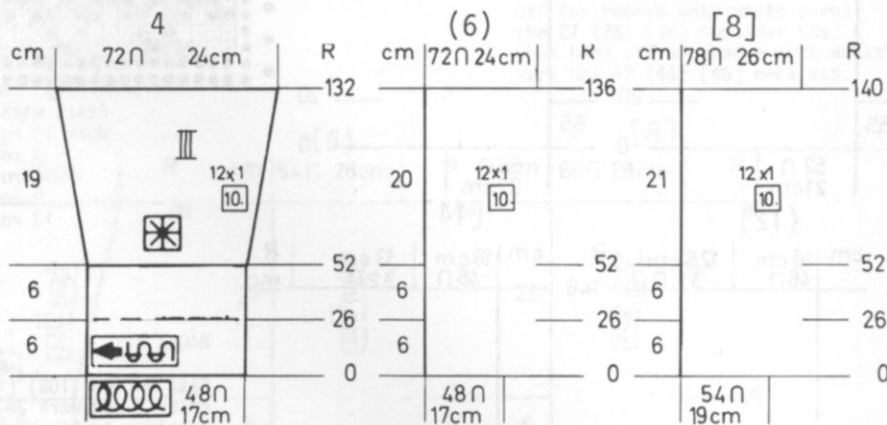
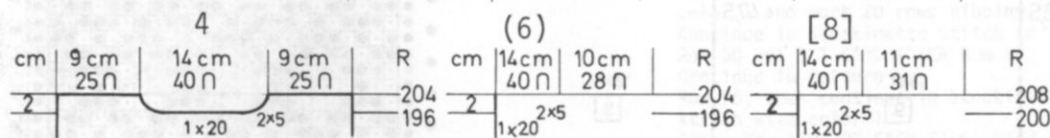

SLEEVES: III

Cast on 48 (48) [54] sts. with color 1 and work 52 rows Stockinette stitch. Continue in Pattern. ON EACH SIDE, increase 1 st. every 10th row 12x for all sizes. After Row 132 (136) [140], bind off.

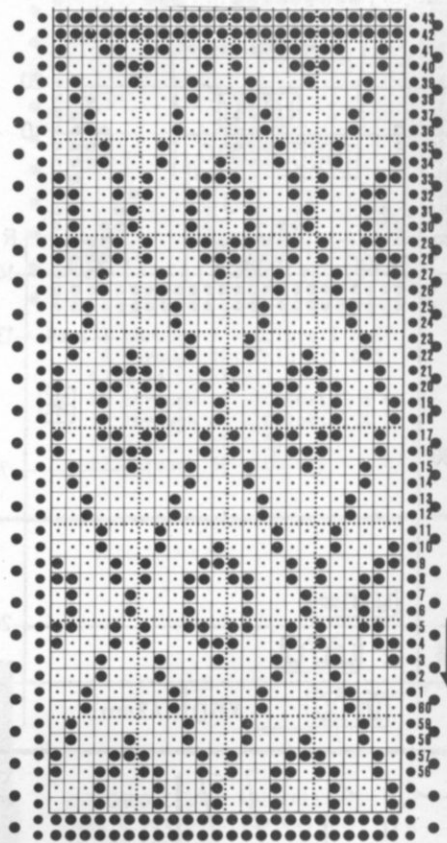

KK 770

CHILD'S PULLOVER

SIZES: 10 (12) [14]
 YARN: Crocus
 GRAMS:
 color 1 300 350 350
 color 2 50 50 50
 color 3 50 50 50
 TENSION: 6 to 8
 GAUGE: 12 1/2 sts. 17 rows = 5 cm (2")



Stockinette stitch with a Norwegian Design on Yoke and Sleeves. Punch your own Card.
 Bands are K2, P2 (or K1, P1) Ribbing.

FINISHING: See General Instructions. Weave or sew Neckband in place then turn to the inside and sew down.

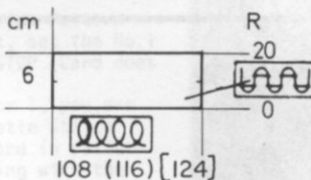

NECKBAND:

Cast on 108 (116) [124] sts. with color 1 and work 20 rows Ribbing. Bind off.

FRONT: I

Work the front the same as the back to Row 132 (136) [140]. Put half the sts. on the left into holding position and complete the right side first.

*ON NECK SIDE, bind off 11 sts. 1x, 4 sts. 3x for all sizes.

Bring the needles on the left into working position, knit 1 row to the left side, turn the Row Counter back to 132 (136) [140] and complete the left half. Follow the instructions from *.

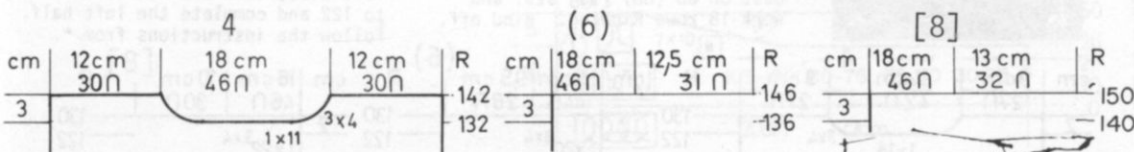

KK 770

SLEEVES: III

Cast on 50 (52) [56] sts. with color 1 and work 20 rows Ribbing. Continue in Stockinette stitch. ON EACH SIDE, increase 1 st. every 9th row 18x for all sizes BUT AT THE SAME TIME, after Row 110, Work the Norwegian Design to Row 170. Continue in Stockinette stitch with color 1. After Row 174 (177) [180], bind off the remaining sts. [14]

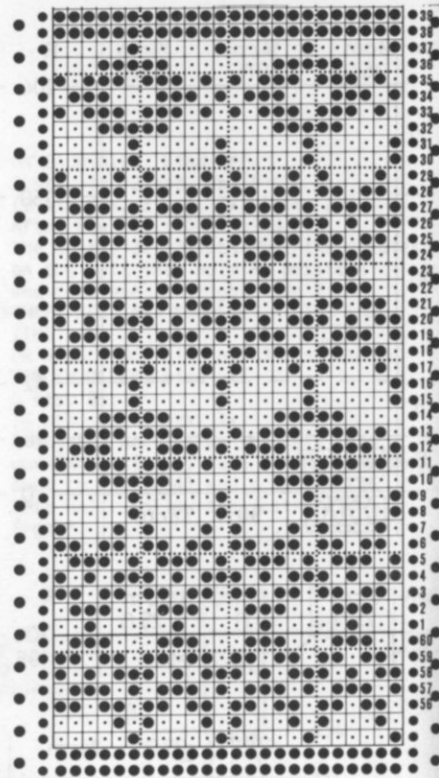
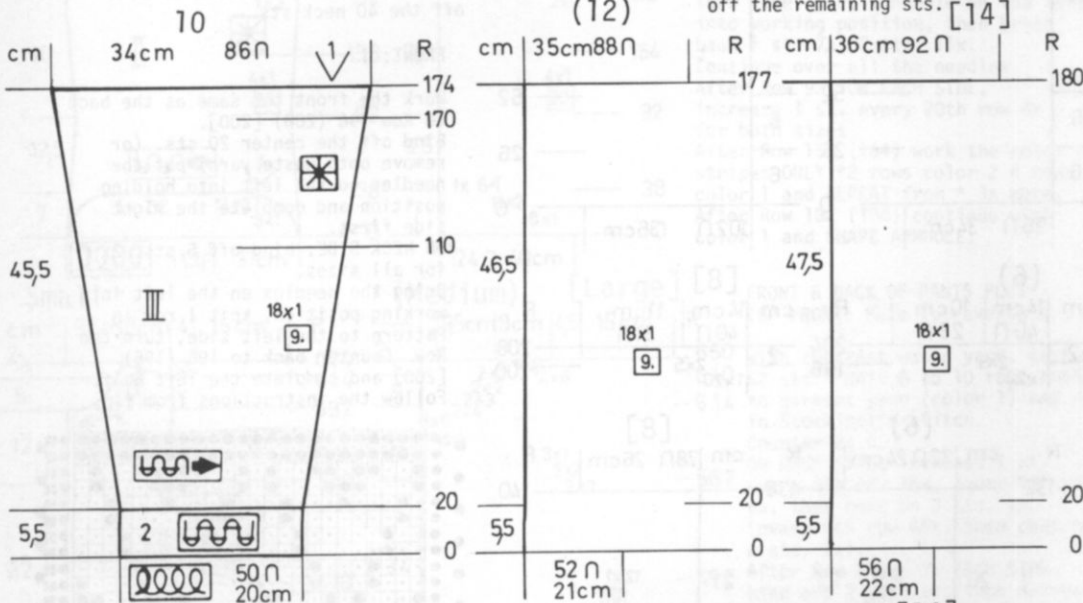

Start with Row 2 on Card. Work 13 rows Color 1 & 2
9 rows color 1 & 3
13 rows color 1 & 2
9 rows color 1 & 3
13 rows color 1 & 2

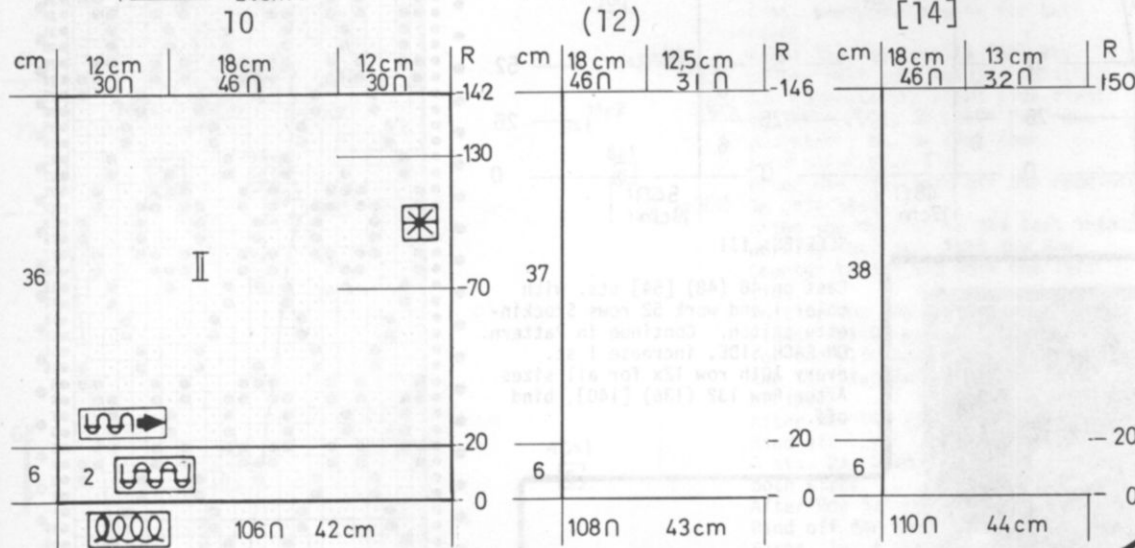

BACK: II

Cast on 106 (108) [110] sts. with color 1 and work 20 rows Ribbing. Continue in Stockinette stitch. Knit to Row 70. Continue in the Norwegian Design. Knit to Row 130 then continue in Stockinette stitch with color 1. After Row 142 (146) [150], remove the 30 (31) [32] shoulder sts. ON EACH SIDE onto contrast waste yarn (or you can bind them off) then do the same for the 46 neck sts.

FRONT: I

Work the front the same as the back to Row 122. Bind off the center 18 (20) [22] sts. for neck, put the needles on the left into holding position and complete the right side first. *ON NECK SIDE, bind off 4 sts. 3x for all sizes. After Row 130, bind off the remaining sts. Bring the needles on the left into working position, knit 1 row to the left side, turn the Row Counter back to 122 and complete the left half. Follow the instructions from *.

KK 771

CHILD'S PULLOVER

SIZES: 4 (6) [8]
YARN: Amore
GRAMS:
color 1 200 200 250
color 2 50 50 50
color 3 50 50 50
color 4 50 50 50
TENSION: 6 to 8
GAUGE: 15 sts. 19 rows = 5 cm (2")



NECKBAND:

Cast on 80 (86) [92] sts. and work 18 rows Ribbing. Bind off.

Stockinette stitch with a Norwegian Design Punch your own Card. Bands are K1, P1 Ribbing.

FINISHING: See General Instructions.

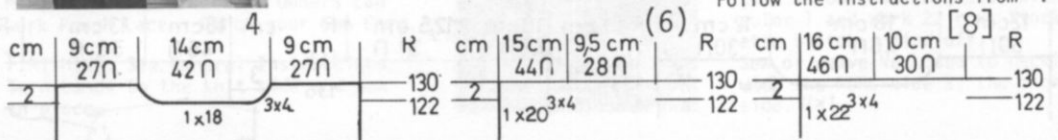

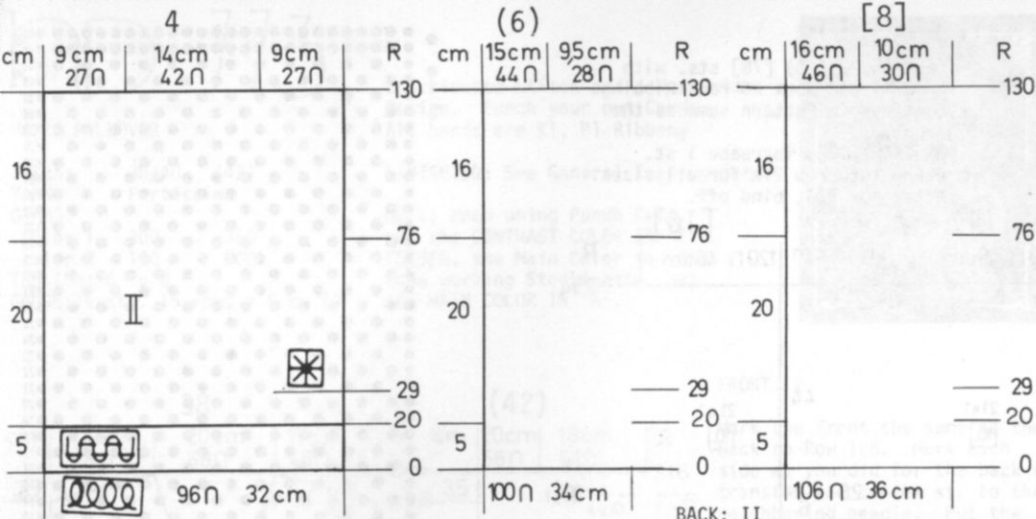

BACK: II

SLEEVES: III

Cast on 48 (52) [54] sts. with color 1 and work 24 rows Ribbing. Continue in Stockinette stitch. ON EACH SIDE, increase 1 st. every 4th row 12x, every 2nd row 4x. (every 4th row 13x, every 2nd row 3x). [every 4th row 14x, every 3rd row 2x.] After Row 80 (84) [88], bind off the remaining sts.

CAST on 96 (100) [106] sts. with color 1 and work 20 rows Ribbing. Continue in Stockinette stitch to Row 30 BUT SET CARD AFTER ROW 29. Continue in Pattern to Row 76, then continue in Stockinette stitch with color 1. After Row 130, ON EACH SIDE, bind off (or remove onto waste yarn) the 27 (28) [30] shoulder sts. then bind off or remove onto waste yarn the 42 (44) [46] neck sts.

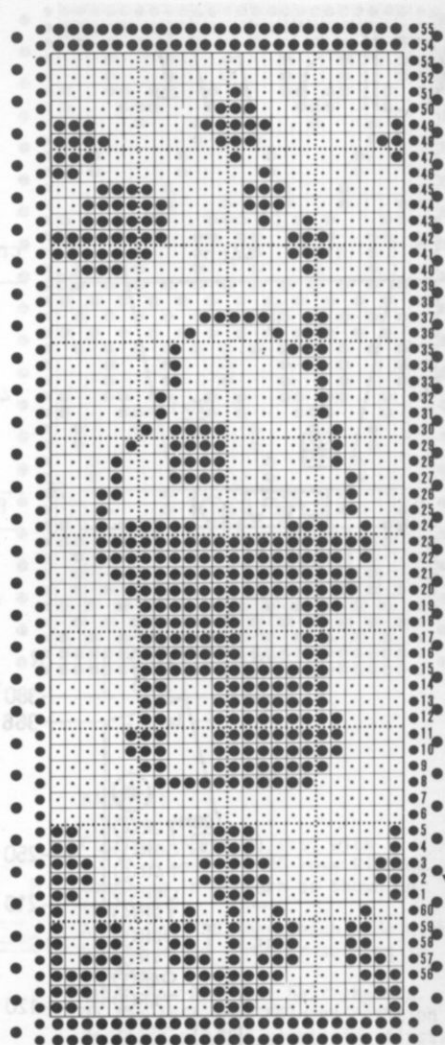
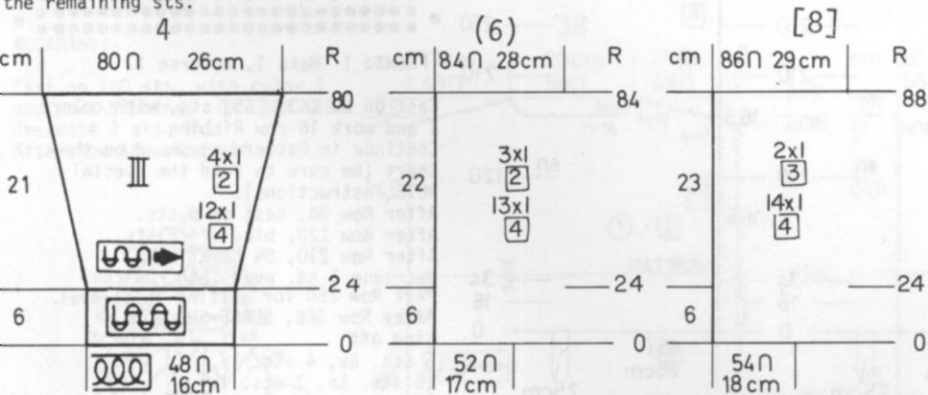

Rows 1 through 7 - Colors 1 & 2
 8 through 12 - Colors 1 & 3
 13 & 14 - Color 1
 15 through 31 - Colors 1 & 4
 32 through 44 - Colors 1 & 3
 45 & 46 - Color 1
 47 through 58 - Colors 1 & 4

dk 772

WOMAN'S JACKET

SIZES: 12 (14) [16]
 YARN: Fortissima
 GRAMS:
 color 1 250 300 350
 color 2 100 100 100
 color 3 100 100 100
 color 4 100 100 100
 TENSION: 7 to 9
 GAUGE: 13 sts. 26 rows = 5 cm (2")

840, 830, 820 Machine Owners, use Card No. 1 of your original set of Cards for this Pattern (SEE NOTE). Bands are K1, P1 Ribbing.

FINISHING: See General Instructions. Sew bands in place, finish Buttonholes and sew on Buttons.

NOTE: When working stripe Pattern as shown on Front Chart, set the No.1 Pattern Card on 1 and STOP (Card does not move). When knitting with color 1, you are knitting plain Stockinette stitch (although the needles are in pattern each row). When knitting with the contrast colors, you ALWAYS PUSH IN THE LEFT TUCK AND THE RIGHT PART BUTTONS. Release the buttons when knitting with main color to do plain knitting. REPEAT the Pattern.



BUTTONHOLE BAND AND COLLAR. Make 2 but omit the buttonholes in 2nd section.

Cast on 200 sts. with color 1 and work in Ribbing. After Row 10, Make Buttonholes over needles 25 to 30, 50 to 55, 75 to 80, 100 to 105 counting from the RIGHT edge. REPEAT the buttonholes over same needles after Row 26. After Row 37, ON OPPOSITE SIDE OF SLIDE, put into holding position 100 sts. then on OPPOSITE SIDE OF SLIDE, put 10 sts. 7x into holding position. After Row 50, bind off. Reverse shaping for 2nd section and omit the buttonholes.

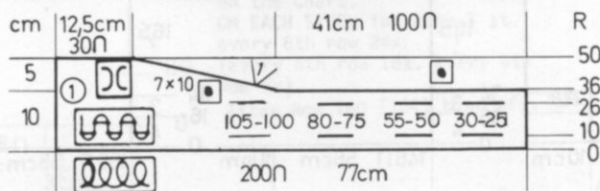

dk 772

SLEEVES: III

Cast on 72 (78) [78] sts. with color 1 and work 26 rows Ribbing. Continue in Pattern same as the front.

ON EACH SIDE, increase 1 st. every 10th row 21x for all sizes. After Row 254, bind off.

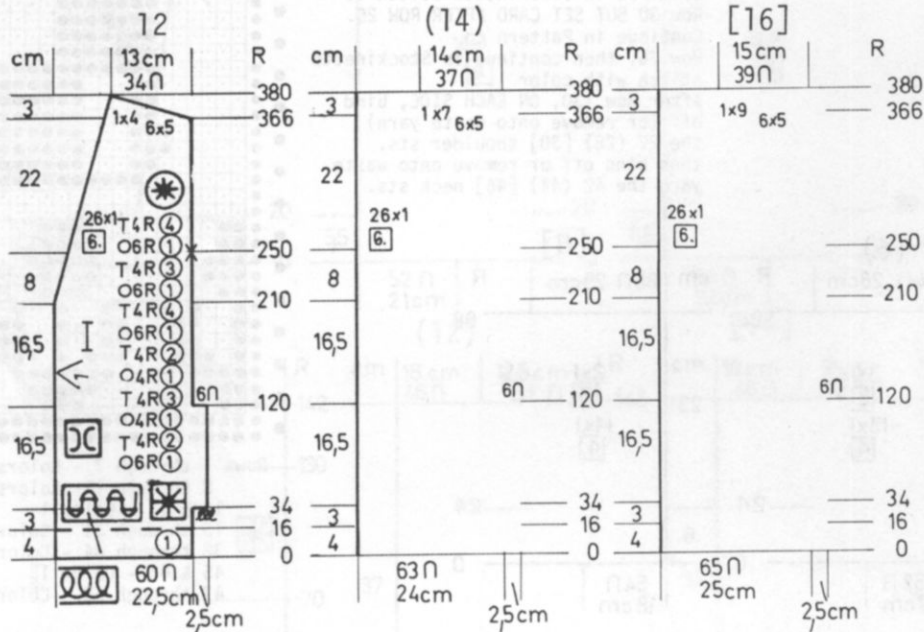
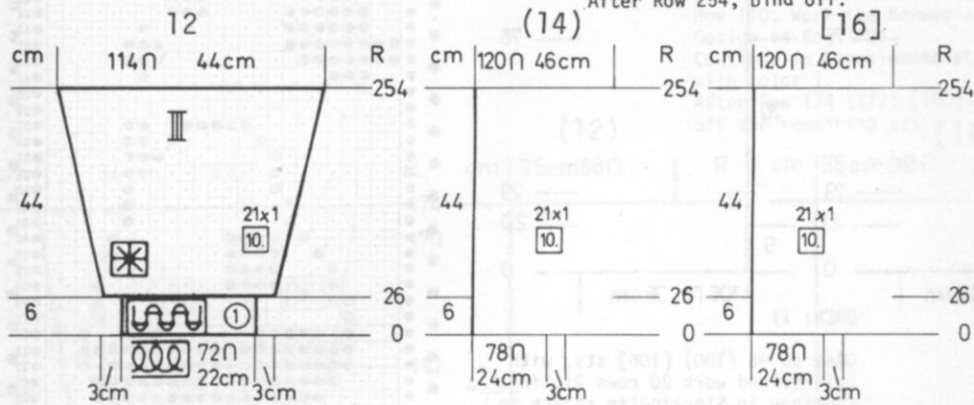

○ PLAIN
T ← TUCK + PART →

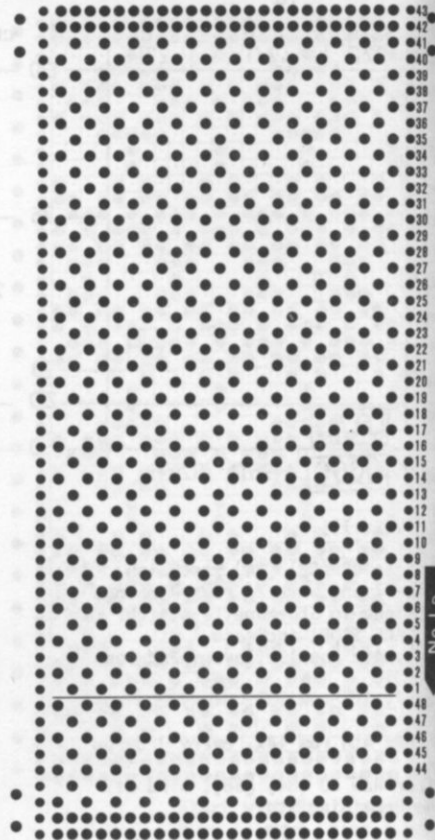

FRONT: I Make 1, reverse 1.

Cast on 60 (63) [65] sts. with color 1 and work 16 row Ribbing. Continue in Pattern as shown on the Chart (Be sure to read the special NOTE instructions).

After Row 34, cast on 6 sts. After Row 120, bind off 6 sts. After Row 210, ON FRONT EDGE, decrease 1 st. every 6th row 26x. Mark Row 250 for setting in sleeves. (5 sts. 6x, 7 sts. 1x). After Row 366, SHAPE SHOULDER. Bind off 5 sts. 6x, 4 sts. 1x. (5 sts. 6x, 7 sts. 1x). [5 sts. 6x, 9 sts. 1x].

BACK: II

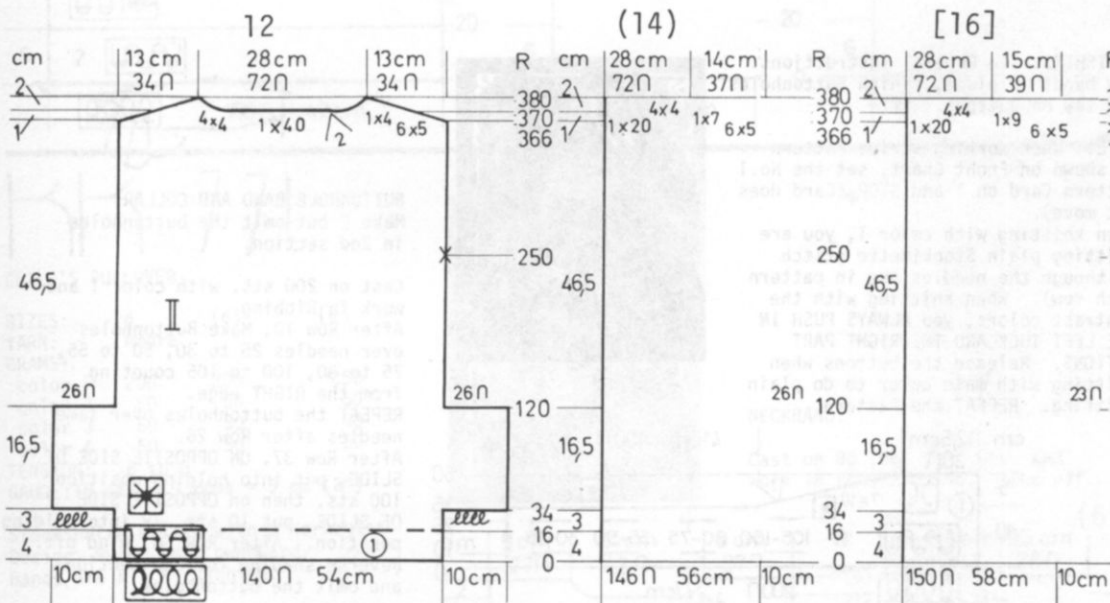

Cast on 140 (146) [150] sts. and work 16 rows Ribbing. Continue in Pattern with the color stripes as shown on the FRONT: After Row 34, ON EACH SIDE, cast on 26 sts. After Row 120, ON EACH SIDE, bind off 26 sts. Knit to Row 250, mark each side with bit of contrast yarn for setting in sleeve. After Row 366, SHAPE SHOULDER: ON EACH SIDE, bind off (watch for neck shaping) 5 sts. 6x, 4 sts. 1x, (5 sts. 6x, 7 sts. 1x), [5 sts. 6x, 9 sts. 1x], AT THE SAME TIME, after Row 370, SHAPE NECK: Bind off the center 40 sts., put the needles on the left into holding position and complete the right side first. *ON NECK SIDE, bind off 4 sts. 4x. Bring the needles on the left into working position, knit 1 row in Pattern to the left side, turn the Row Counter back to 370 and complete the left half. Follow the instructions from * but don't forget to complete the shoulder shaping.

np 773

Stockinette stitch and a Norwegian Design. Punch your own Card. All bands are K1, P1 Ribbing.

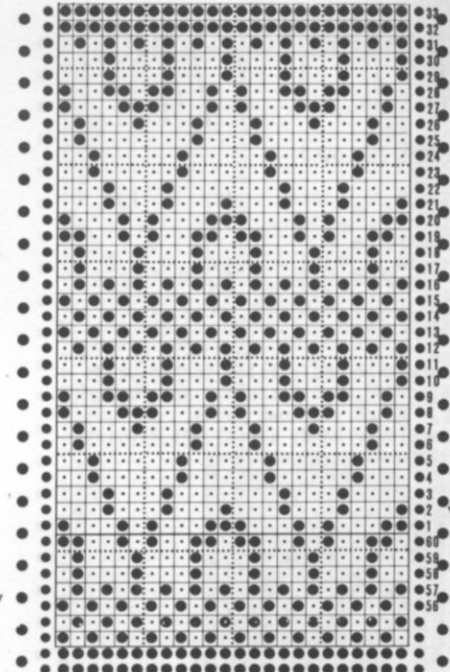

FINISHING: See General Instructions.

NOTE: When using Punch Card, put the CONTRAST COLOR IN 'A' FEEDER, the Main Color in 'B'. When working Stockinette, put the MAIN COLOR IN 'A'.

FRONT: I

Work the front the same as the back to Row 126. Mark each side as you did for the back then transfer the center st. to the neighboring needle. Put the needles on the left into holding position and complete the right side first.

*ON NECK SIDE, decrease 1 st. every 3rd row 28x for both sizes. After Row 206, SHAPE SHOULDER same as the back.

Bring the needles on the left into working position, knit 1 row in pattern to the left side, turn the Row Counter back to 126 and complete the right half. Follow the instructions from *.

BACK: II

Cast on 153 (158) sts. with color 1 and work 30 rows Ribbing. Continue in Pattern as shown on the Chart.

After Row 126, mark each side with bit of waste yarn for setting in sleeves.

After Row 206, put half the sts. on the left into holding position and complete the right side first. *SHAPE SHOULDER AND NECK AT THE SAME TIME.

FOR SHOULDER, bind off 9 sts. 4x, 12 sts. 1x. (10 sts. 4x, 11 sts. 1x).

FOR NECK: bind off 16 sts. 1x, 4 sts. 3x for both sizes.

Bring the needles on the left into working position, knit 1 row to the left side, turn the Row Counter back to 206 and complete the left half. Follow the instructions from *.

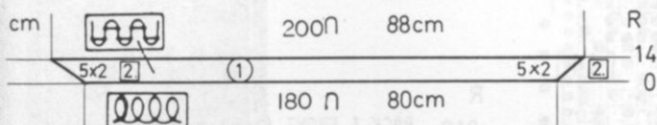
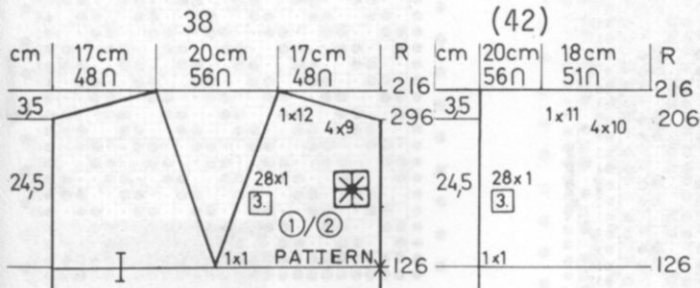

NECKBAND:

Cast on 180 sts. with color 1 and work Ribbing. ON EACH SIDE increase 2 sts. 5x. After Row 14, bind off.

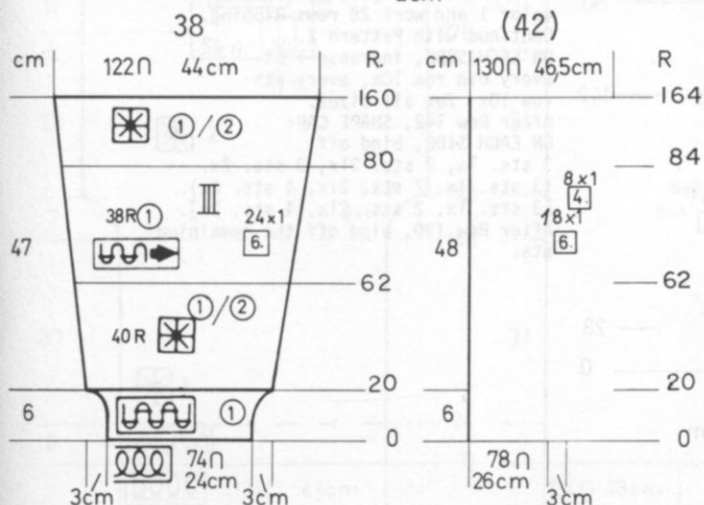
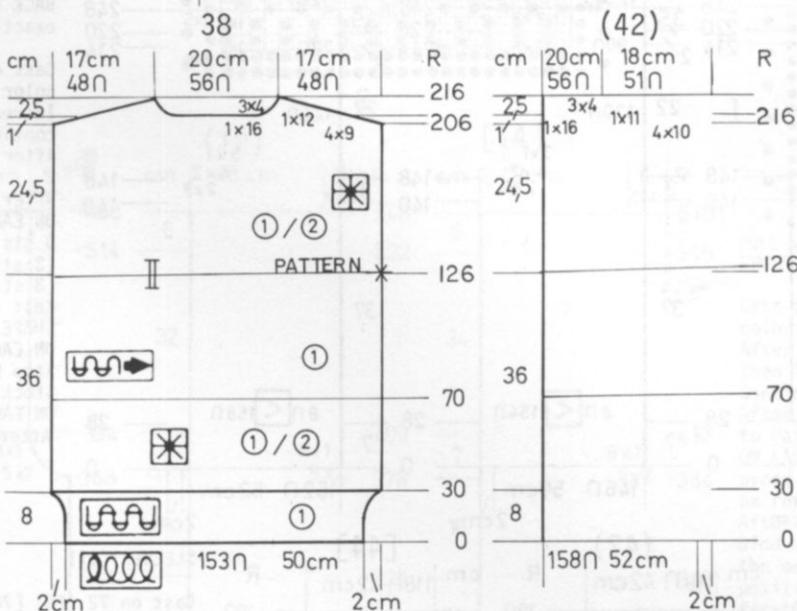

SLEEVES: III

Cast on 74 (78) sts. with color 1 and work 20 rows Ribbing. Continue in Pattern as shown on the Chart.

ON EACH SIDE, increase 1 st. every 6th row 24x. (every 6th row 18x, every 4th row 8x).

After Row 160 (164) bind off.



hp 774

MAN'S PULLOVER

SIZES: 38/40 (42) [44]
 YARN: Vienna
 GRAMS:
 color 1 400 400 450
 color 2 350 350 400
 TENSION: 9 or 10
 GAUGE: 14 sts. 15 rows = 5 cm (2")

Norwegian (Fair Isle) technique is used for both Pattern 1 and Pattern 2. Punch your own Cards. Sleeves and lower bands are K1, P1 Ribbing.

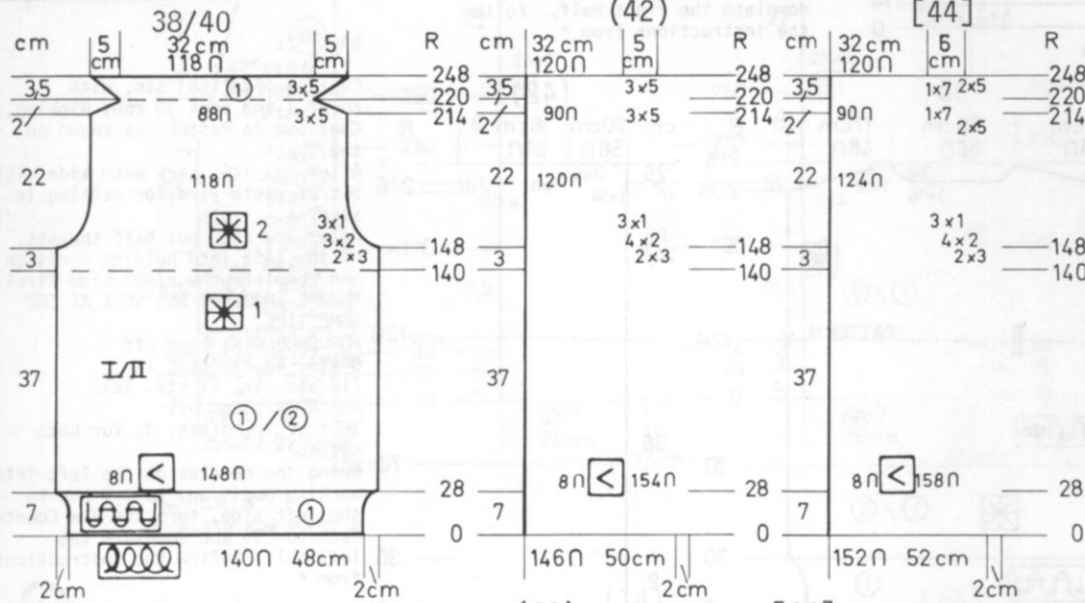
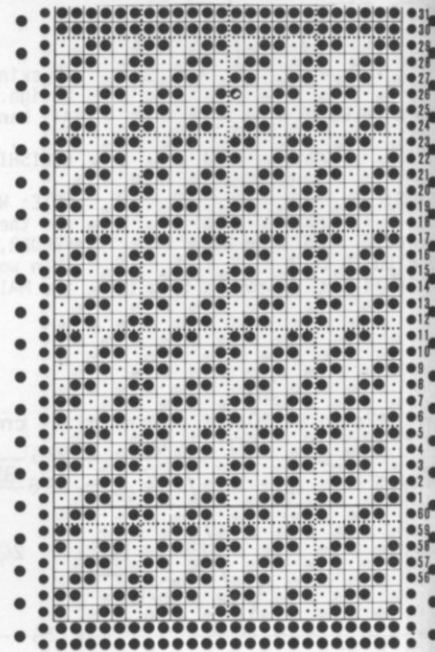
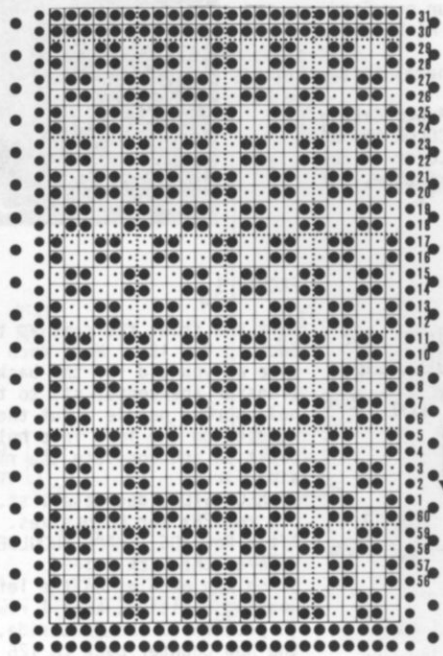

BACK & FRONT (both sections are exactly the same so knit 2 pieces).

Cast on 140 (146) [152] sts. with color 1 and work 28 rows Ribbing. Increase 8 sts. evenly across and continue in Pattern 1. After Row 140, change to Pattern 2.

After Row 148, SHAPE ARMHOLE: ON EACH SIDE, bind off 3 sts. 2x, 2 sts. 3x, 1 st. 3x. (3 sts. 2x, 2 sts. 4x, 1 st. 3x). [3 sts. 2x, 2 sts. 4x, 1 st. 3x]. Knit to Row 214.

SHAPE SHOULDER AND NECK: ON EACH SIDE, bind off 5 sts. 3x. Stop Pattern and Continue with Stockinette with color 1. ON EACH SIDE, cast on 5 sts. 3x. After Row 248, bind off.

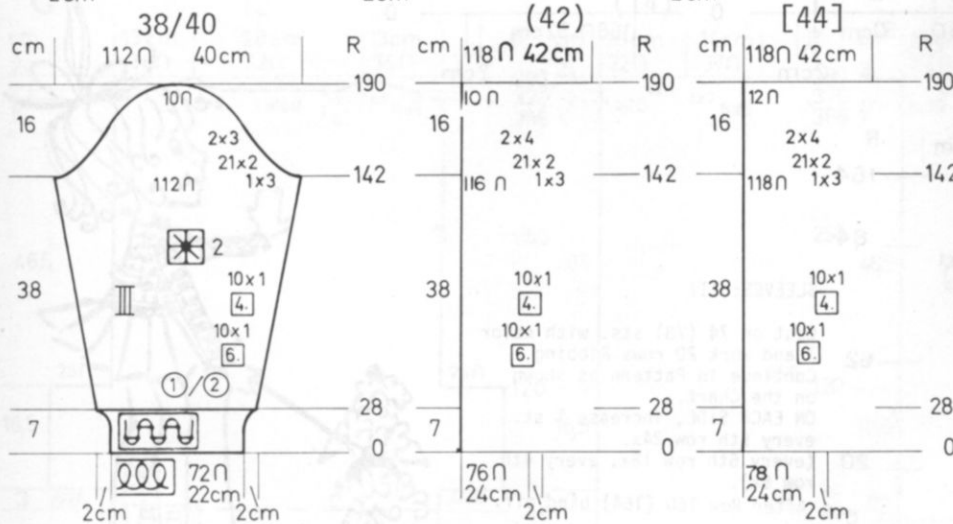

SLEEVES: III

Cast on 72 (76) [78] sts. with color 1 and work 28 rows Ribbing. Continue with Pattern 2. ON EACH SIDE, increase 1 st. every 6th row 10x, every 4th row 10x for all sizes. After Row 142, SHAPE CAP: ON EACH SIDE, bind off 3 sts. 1x, 2 sts. 21x, 3 sts. 2x. (3 sts. 1x, 2 sts. 21x, 4 sts. 2x). [3 sts. 1x, 2 sts. 21x, 4 sts. 2x]. After Row 190, bind off the remaining sts.

dk 775

WOMAN'S PULLOVER & JACKET

SIZES: 8/10 (12) [14]
YARN: C-1 = Amore, C-2 = Micaela
GRAMS:
 color 1 600 600 650
 color 2 250 250 300
TENSION: 6 to 8
GAUGE: 14 sts. 20 rows = 5 cm (2")

For 840, 830, 820 Machine owners, use Norwegian Technique with the knit side as the right side. Studio Machine owners, use Punch Lace on the purl side. Punch your own cards. Bands are Stockinette stitch with a picot row.

FINISHING: See General Instructions. Sew all bands with 1 edge on outside and 1 to the inside.



PICOT ROW for all bands.
 Transfer every 2nd stitch to neighboring needle and leave empty needle in work.

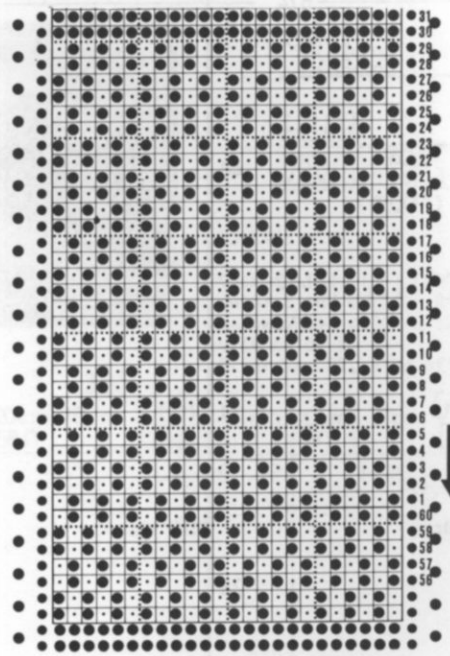

2

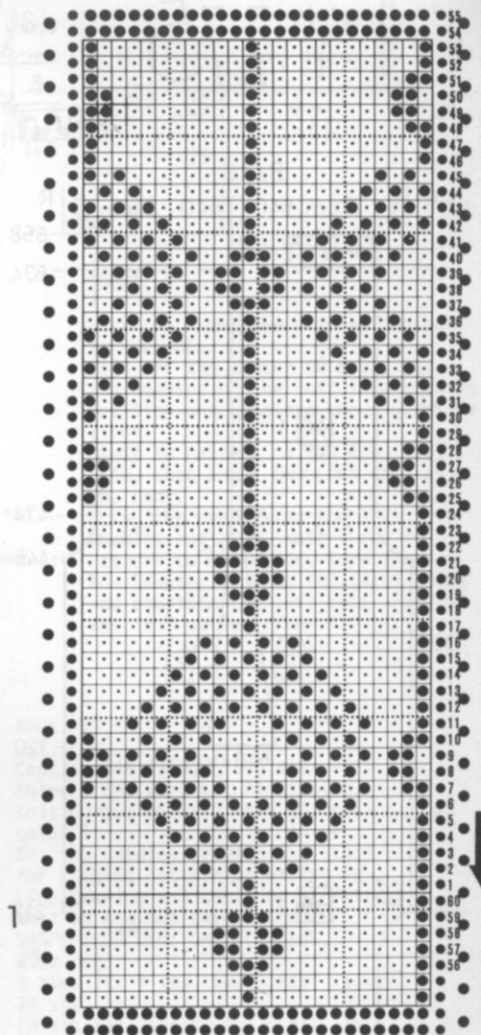

1

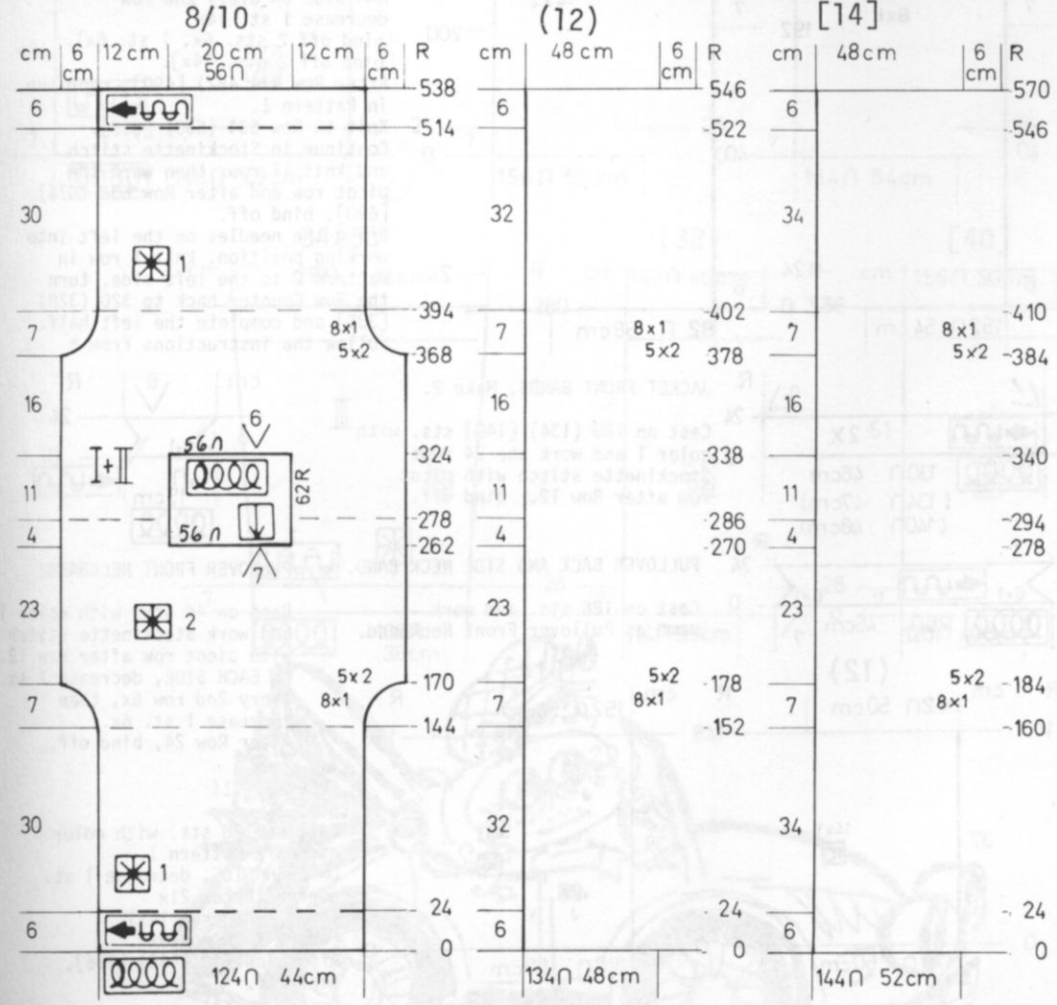

PULLOVER FRONT & BACK Make in 1 piece.

Cast on 124 (134) [144] sts. with color 1 and work Stockinette stitch. After Row 12, work Picot across then knit to Row 24. Continue in Pattern 1. After Row 144 (152) [160], change to Pattern 2 and SHAPE ARMHOLE: ON EACH SIDE, increase 1 st. every 2nd row 8x, then 2 sts. 5x for all sizes. After Row 262 (270) [278], Bind off the center 56 sts. put the needles on the left into holding position and complete the right side first. *Mark Row 278 (286) [294] for shoulder then knit to Row 324 (338) [340]. Put these needles into holding position. Bring the needles on the left into working position, turn the Row Counter back to 262 (270) [278] and work the left half (watch pattern). Knit to Row 278 (286) [294] then follow the instructions from * to Row 324 (338) [340]. Cast on 56 sts. for neck then continue over all the needles. Knit to Row 368 (378) [384]. SHAPE ARMHOLE: ON EACH SIDE, cast on 2 sts. 5x, 1 st. 8x for all sizes. Continue in Pattern 1. Knit to Row 514 (522) [546], then continue in Stockinette stitch with color 1. Knit 12 rows then work the picot row and knit to Row 538 (546) [570]. Bind off.



dk 775

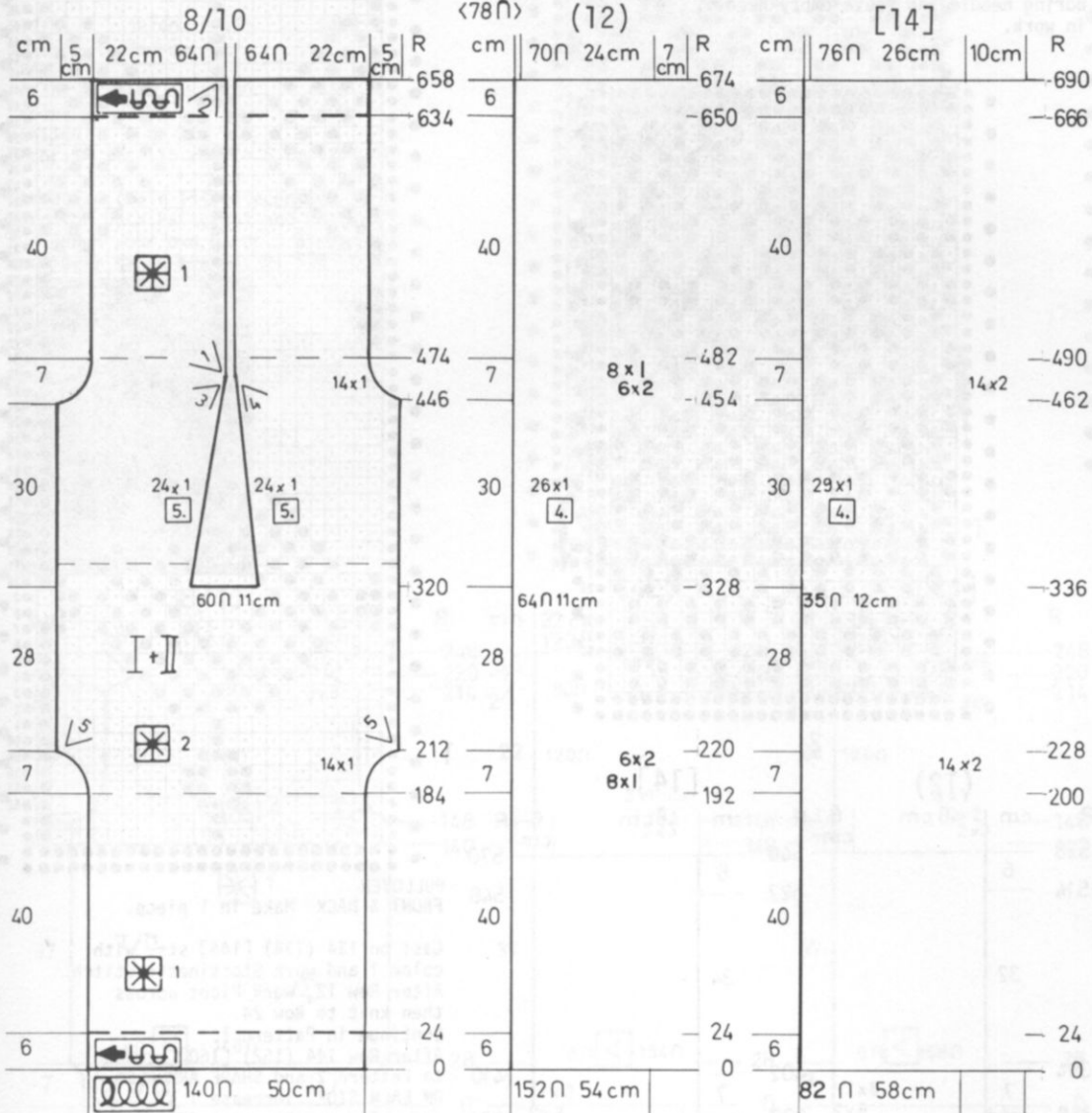
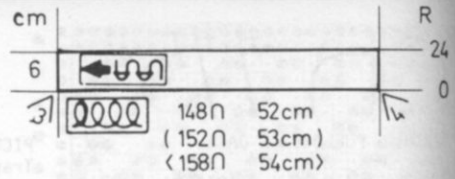
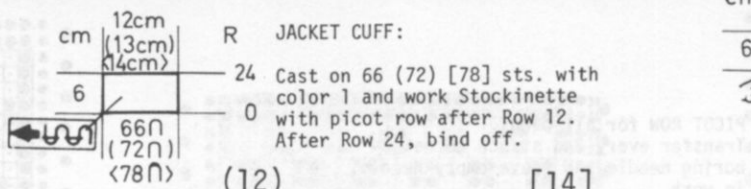

JACKET FRONT & BACK NECK BAND
Cast on 148 (152) [158] sts. and work the 24 rows Stockinette stitch with picot row after Row 12. Bind off.

JACKET FRONT & BACK: Make in 1 piece for first 2 sizes. For size 14, work the back in 2 sections.

Cast on 140 (152) [82] sts. with color 1 and work Stockinette stitch. Make picot row after Row 12 then knit to Row 24. Continue in Pattern I. Knit to Row 184 (192) [200]. Continue in Pattern 2. **SHAPE ARMHOLE: ON EACH SIDE** increase 1 st. every 2nd row 14x. (1 st. every 2nd row 8x, then cast on 2 sts. 6x). [ON ARM SIDE, cast on 2 sts. 14x]. Knit to Row 320 (328) [336]. Bind off the center 60 (64) [On neck side bind off 35] sts., put the needles on the left into holding position and complete the right side first. *ON NECK SIDE, increase 1 st. every 5th row 24x. (every 4th row 26x). [every 4th row 29x]. After Row 446 (454) [462], ON ARM SIDE on every 2nd row decrease 1 st. 14x. (bind off 2 sts. 6x, 1 st. 8x). [bind off 2 sts. 14x]. After Row 474 482) [490], continue in Pattern I. Knit to Row 634 (650) [666]. Continue in Stockinette stitch and knit 12 rows then work the picot row and after Row 658 (674) [690], bind off. Bring the needles on the left into working position, knit 1 row in Pattern 2 to the left side, turn the Row Counter back to 320 (328) [336] and complete the left half. Follow the instructions from *

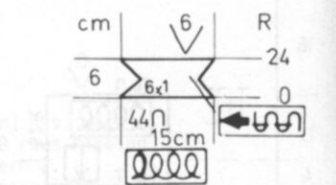
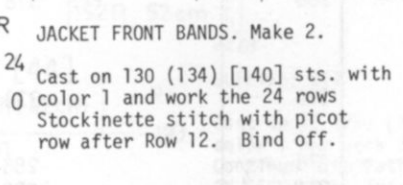
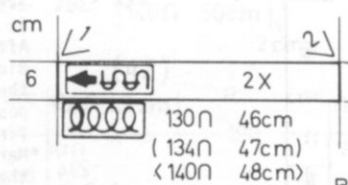
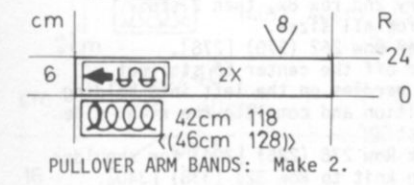

Cast on 118 (128) [128] sts. with color 1 and work Stockinette stitch. After Row 12, work the picot row then knit to Row 24 and bind off.

Cast on 130 (134) [140] sts. with color 1 and work the 24 rows Stockinette stitch with picot row after Row 12. Bind off.

Cast on 126 sts. and work same as Pullover Front Neckband.

Cast on 44 sts. with color 1 and work Stockinette stitch with picot row after row 12. ON EACH SIDE, decrease 1 st. every 2nd row 6x, then increase 1 st. 6x. After Row 24, bind off.

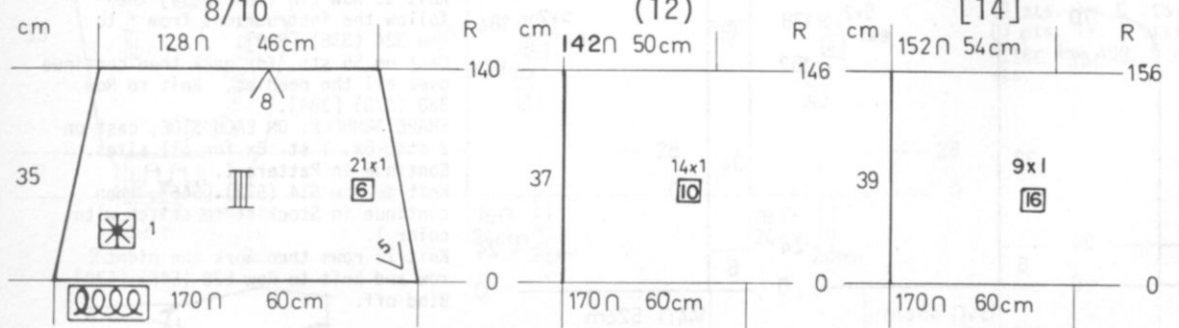

SLEEVES: III

Cast on 170 sts. with color 1 and work Pattern I. ON EACH SIDE, decrease 1 st. every 6th row 21x (every 10th row 14x). [every 16th row 9x]. After Row 140 (146) [156], bind off.

OK 777

WOMAN'S COAT

SIZES: Small (Medium) [Large]
YARN: Color 1 - Wool
 color 2 - Medium Brown } Heavy tweed
 color 3 - Dark Brown } yarn for
 color 4 - Beige } Weaving

GRAMS:
 color 1 1 lb. 8 oz.
 color 2 400 grams
 color 3 200 grams
 color 4 700 grams

TENSION: 7 to 9
GAUGE: 13 sts. 21 rows = 5 cm (2")

A Weaving Pattern. Punch your own Card.

FINISHING: Sew the 3 back sections together. Sew Yoke to back waist easing into yoke. Sew shoulder and side seams then put sleeves in. Turn under all edges and stitch in place. Fold Collar lengthwise and sew together on the inside. Turn front edges under and stitch in place. Sew on fur hooks evenly spaced 1.5 cm from edge. When coat is completely put together, cut the long floats.



WEAVE with 2 rows color 3
 4 rows color 2
 10 rows color 4
 REPEAT FROM BEGINNING.

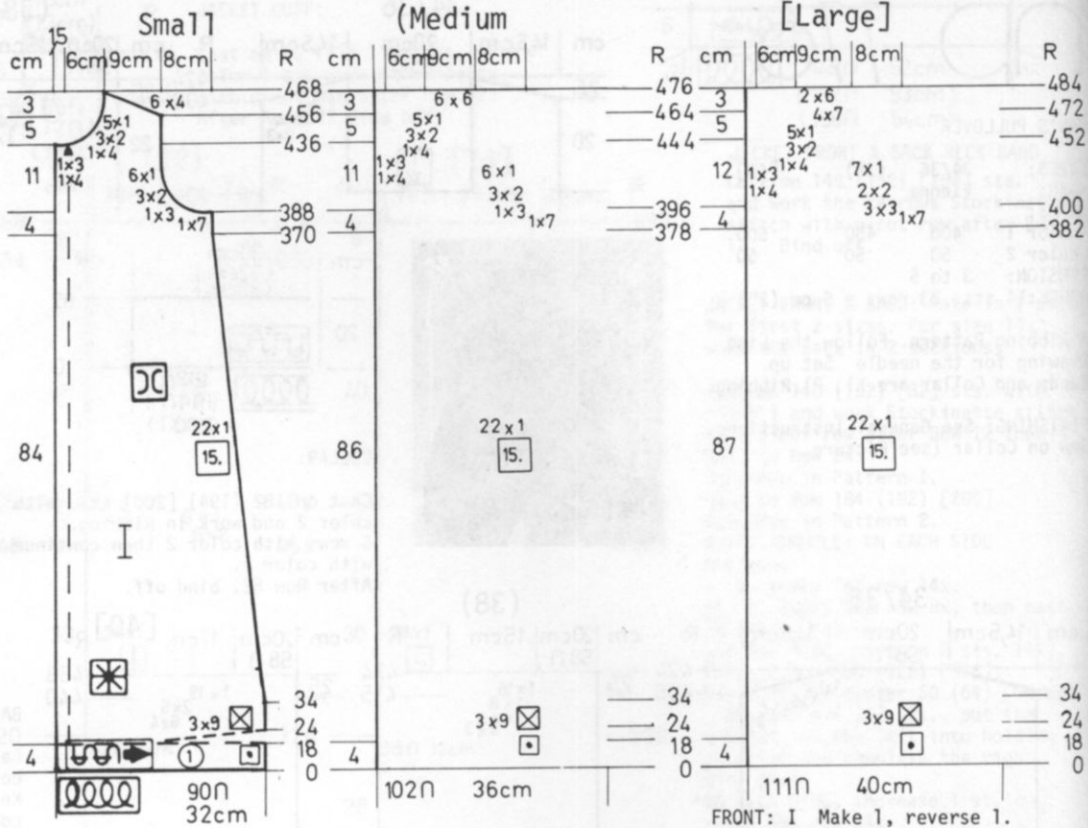
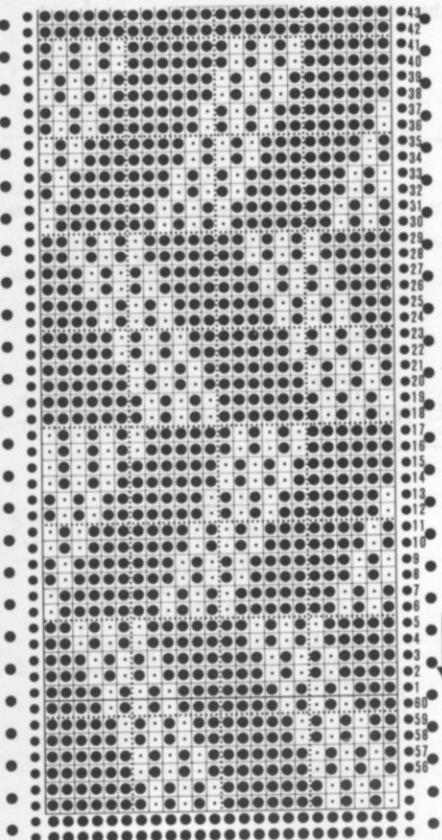

FRONT: I Make 1, reverse 1.

Cast on 90 (102) [111] sts. with color 1 and work Stockinette stitch to Row 17. ON OPPOSITE SIDE OF SLIDE, put into holding position, 27 sts. then on every 2nd row, bring back into working position 9 sts. 3x.

SLEEVES: III

Cast on 54 (54) [60] sts. with color 1 and work Stockinette stitch to Row 32. REVERSE THE KNITTING, then continue in Pattern.
 ON EACH SIDE, increase 1 st. every 9th row 2x, every 10th row 14x.
 (every 10th row 16x).
 [every 10th row 16x].
 After Row 190 (194) [198], SHAPE CAP: ON EACH SIDE, bind off 3 sts. 1x, 2 sts. 2x, 1 st. 25x, 2 sts. 1x, 3 sts. 1x.
 (Same as first size).
 [3 sts. 1x, 2 sts. 2x, 1 st. 25x, 2 sts. 1x, 4 sts. 1x].
 After Row 252 (256) [260], bind off the remaining sts.

Continue in Pattern.
 ON SIDE EDGE, decrease 1 st. every 15th row 22x for all sizes.
 After Row 370 (378) [382], SHAPE ARMHOLE: Bind off 7 sts. 1x, 3 sts. 1x, 2 sts. 3x, 1 st. 6x.
 (Same as first size).
 [7 sts. 1x, 3 sts. 3x, 2 sts. 2x, 1 st. 7x].
 After Row 435 (443) [451], SHAPE NECK: For all sizes, bind off 4 sts. 1x, 3 sts. 1x, 4 sts. 1x, 2 sts. 3x, 1 st. 5x.
 After Row 456 (464) [472], SHAPE SHOULDER: Bind off 4 sts. 6x.
 (6 sts. 6x).
 [7 sts. 4x, 6 sts. 2x].

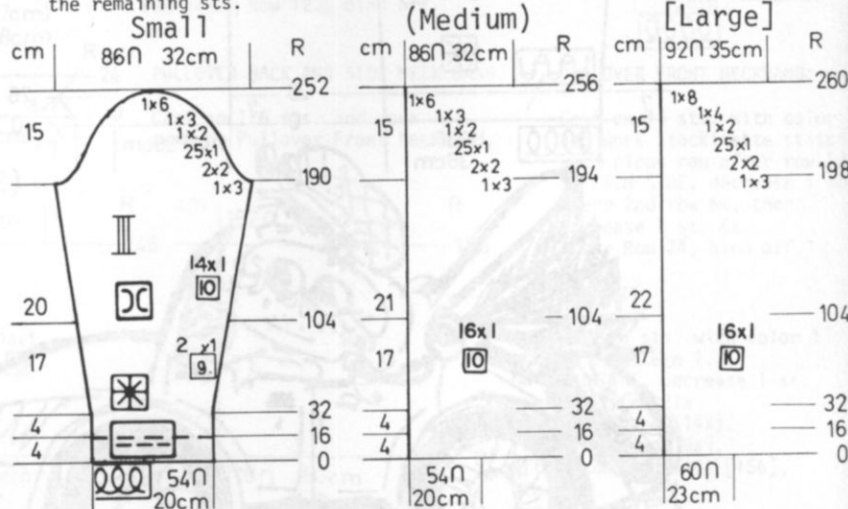

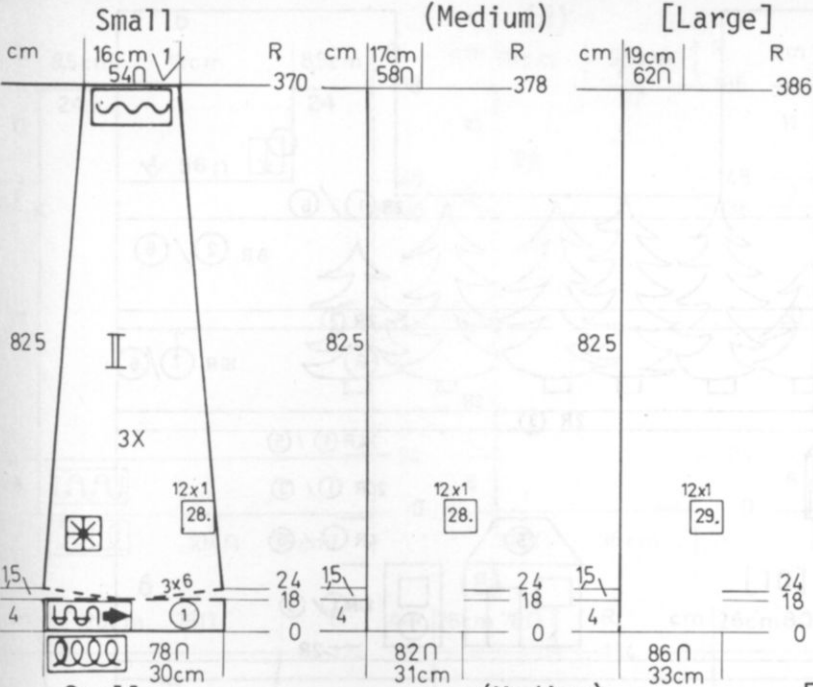

LOWER BACK: Make 3.

Cast on 78 (82) [86] sts. with color 1 and work Stockinette stitch.
 After Row 18, ON OPPOSITE SIDE OF SLIDE, put into holding position, 18 sts. before knitting the next 2 rows. ON OPPOSITE SIDE OF SLIDE, bring back into working position 6 sts. 3x ON EACH SIDE.
 After Row 24, continue in Pattern. ON EACH SIDE, decrease 1 st. every 28th (28th) [29th] row 12x.
 After Row 370 (378) [386], bind off.

COLLAR:

Cast on 92 sts. with color 1 and work in Pattern.
 Put into holding position, all but 18 sts. on one side. Push back 6 sts. 2x. Put these sts. into holding position and do the same for other side - 32 left in center.
 Work over all needles and ON EACH SIDE, increase 1 st. every 2nd row 10x. After Row 30, ON EACH SIDE decrease 1 st. every other row 10x. Bind off the center 32 sts. Put the left side into holding position and complete right side first. Bind off 6 sts. 2x, then remaining 18. Work the other side the same.

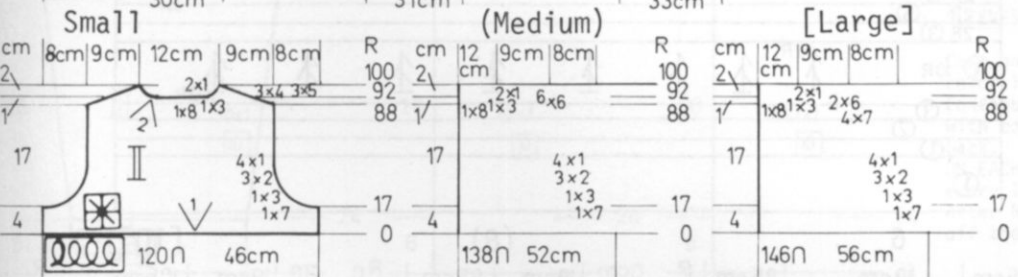

BACK YOKE: II

Cast on 120 (138) [146] sts. with color 1 and work in Pattern.
 After Row 18, SHAPE ARMHOLE: FOR ALL SIZES, ON EACH SIDE, bind off
 7 sts. 1x, 3 sts. 1x, 2 sts. 3x, 1 st. 4x.
 After Row 88, SHAPE SHOULDER (and watch for neck shaping). FOR SHOULDER, bind off
 5 sts. 3x, 4 sts. 3x, (6 sts. 6x), [7 sts. 4x, 6 sts. 2x],

*FOR NECK:
 after Row 92, put half the sts. on the left into holding position and complete the right side first.
 ON NECK SIDE, bind off
 8 sts. 1x, 3 sts. 1x, 1 st. 2x.
 Bring the needles on the left into working position, knit 1 row in Pattern to the left side, turn the Row Counter back to 92 and complete the left half. Follow the instructions from * and don't forget to complete the shoulder shaping.

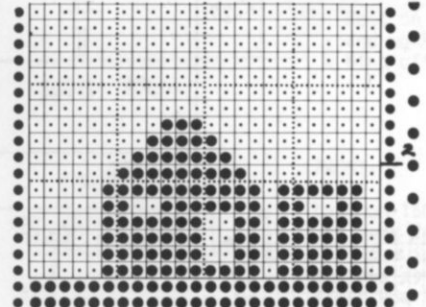
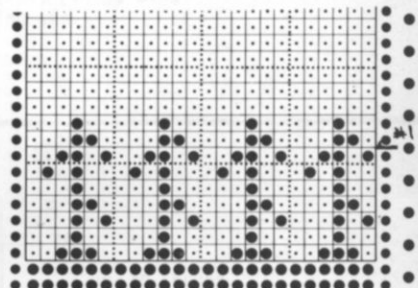

KK 778

CHILD'S PULLOVER



SIZES:	6	(8)	[10]
YARN:	Crocus		
GRAMS:			
color 1	100	150	200
color 2	50	50	50
color 3	50	50	50
color 4	50	50	50
color 5	50	50	50
color 6	100	100	100
color 7	50	50	50
TENSION:	6 TO 8		
GAUGE:	14/1/2 sts. 17 1/2 rows = 5 cm		

Stockinette stitch with Norwegian Technique and isolated Patterns.
 Punch your own cards. Isolate Card No. 1, 2, 3 (see Diagram) for front section. The back and sleeves have stripes only and are the same as the front. Rib Collar insert, lower edge and sleeve cuffs.

FINISHING: See General Instructions. Match V to V (2) lapping right over left for girl or opposite for boy.

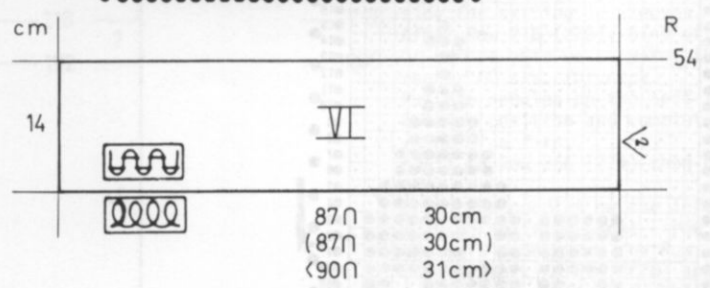

INSERT & COLLAR: VI

Cast on 87 (87) [90] sts. with color 1 and work 54 rows Ribbing. Bind off.



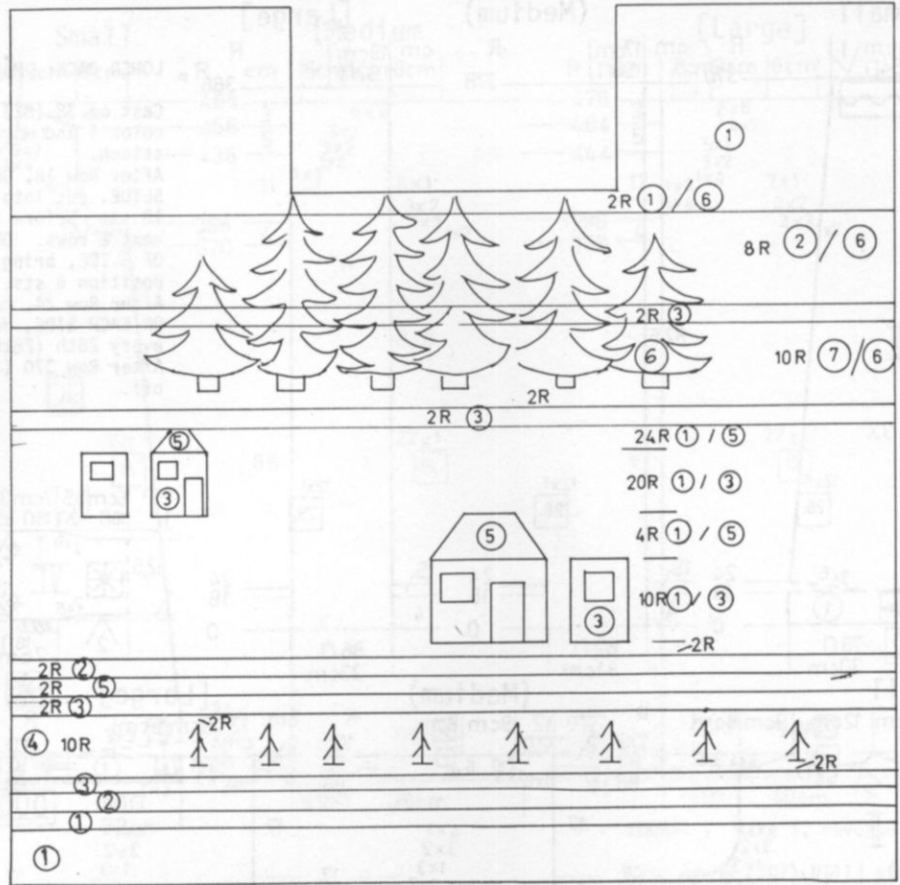
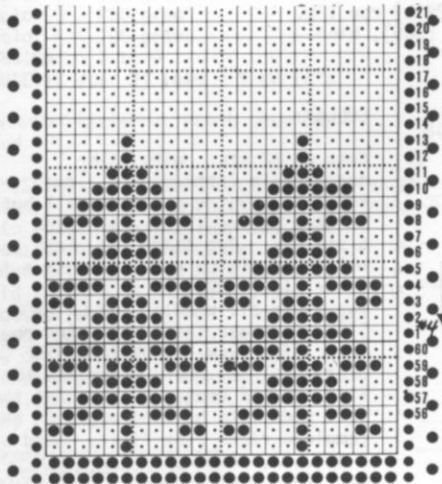

6				(8)				[10]				
cm	8,5cm	19cm	8,5cm	R	cm	19cm	9,5cm	R	cm	19cm	10,5cm	R
	24	56	24	178	13	56	27	186	14	56	30	194
13				X	13			X	14			X
27				128	29			136	30			140
				24				24				24
6	[Ribbing]			0	6	[Ribbing]		0	6	[Ribbing]		0
	104 36cm				110 38cm			116 40cm				

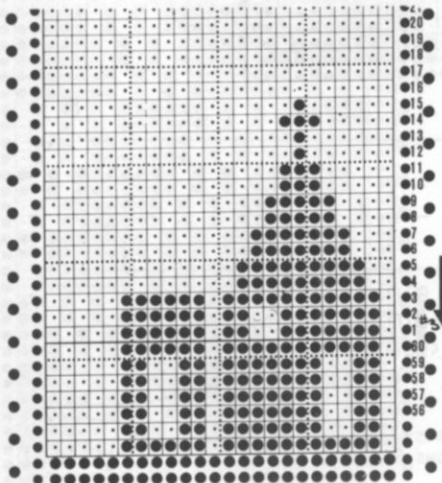

BACK: II

Cast on 104 (110) [116] sts. with color 1 and work 24 rows Ribbing. Continue in Stockinette stitch with color stripes only - same as on the front.

After Row 128 (136) [140], mark each side with bit of contrast yarn for setting in sleeves. Knit to Row 178 (186) [194]. Bind off or remove on waste yarn, the center 56 sts. for neck and each of the 24 (27) [30] shoulder stitches.

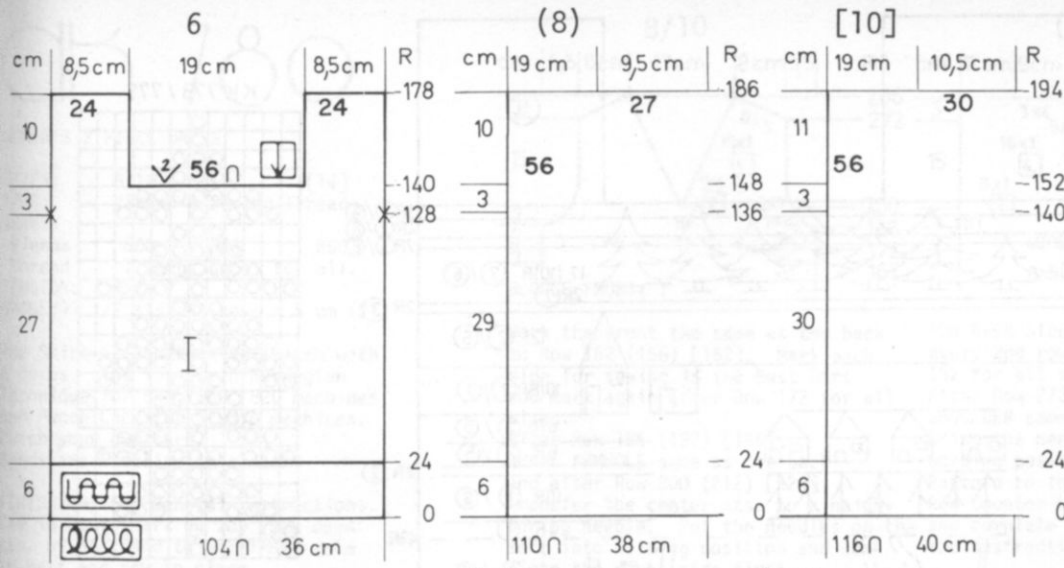

FRONT: I

Cast on 104 (110) [116] sts. with color 1 and work 24 rows Ribbing. After transferring the ribber sts. to main machine, continue to follow the Diagram for the color stripes and isolated patterns. The stockinette stripes are 2 rows of each color as shown. Mark Row 128 on each side for setting in sleeves. After Row 140 (148) [152], bind off or remove onto waste yarn, the center 56 sts. for neck. Put the needles on the left into holding position and complete the right side first. *Knit to Row 178 (186) [194], then bind off the remaining shoulder sts. Bring the needles on the left into working position, knit 1 row to the left side, turn the Row Counter back to 140 (148) [152] and complete the left half. Follow the instructions from *.

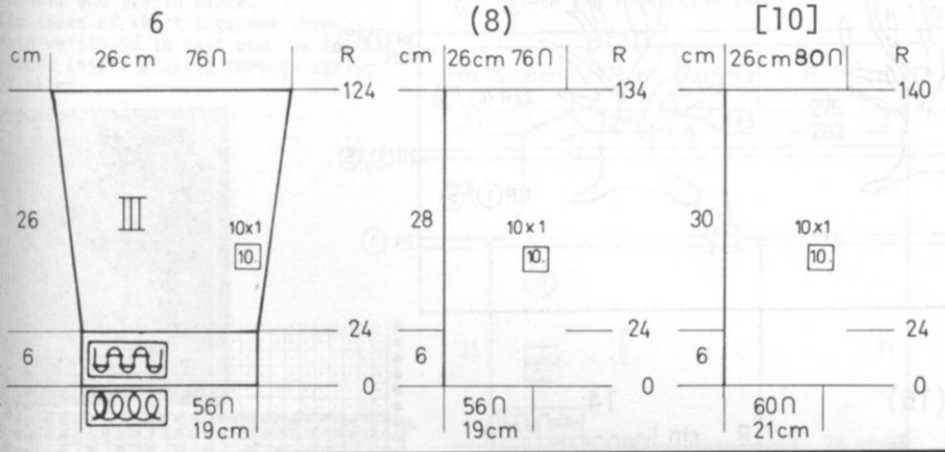

SLEEVES: III

Cast on 56 (56) [60] sts. with color 1 and work 24 rows Ribbing. Continue in Stockinette stitch with color stripes as on front and back. ON EACH SIDE, increase 1 st. every 10th row 10x for all sizes. After Row 124 (134) [140], bind off the remaining sts.

KK 779

TEENAGE PULLOVER

- SIZES: 14 (16)
- YARN: Crocus
- GRAMS:
- color 1 200 250
- color 2 50 50
- color 3 50 50
- color 4 50 50
- color 5 50 50
- color 6 100 100
- color 7 50 50
- TENSION: 5 to 7
- GAUGE: 14 1/2 sts. 19 1/2 rows = 5 cm

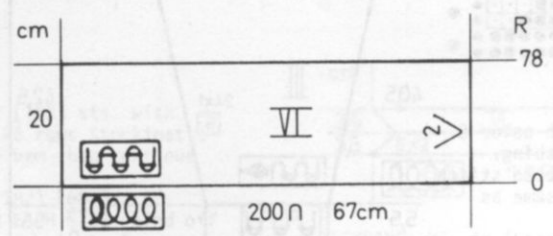

COLLAR-INSERT

Cast on 200 sts. with color 6 and work 78 rows Ribbing. Bind off.

Stockinette stitch with color stripes and a Norwegian Design with isolated patterns on the front section. Follow the diagram for placement of designs and color changes. Punch your own cards. Rib Bands.

FINISHING: See General Instructions. For Collar-insert, match V to V (2) lapping right over left for girl or opposite for boy.

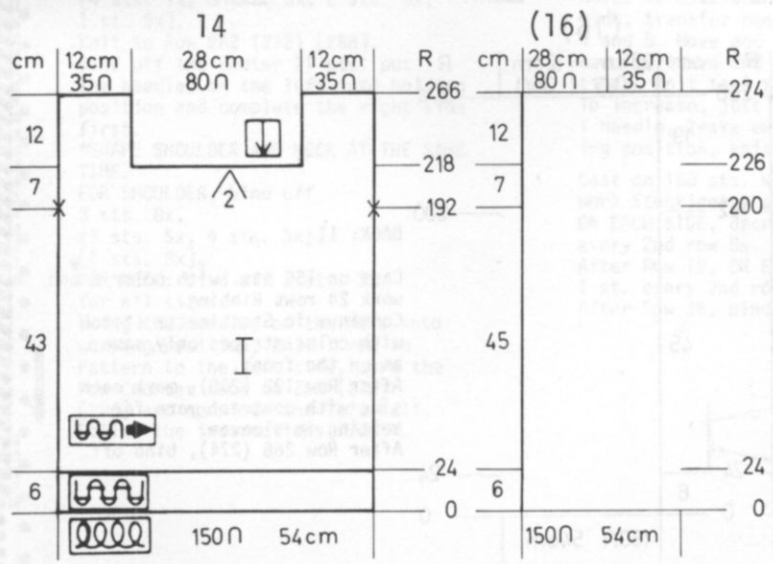

FRONT: I

Cast on 150 sts. with color 6 and work 24 rows Ribbing. Continue in Pattern and color stripes as shown on the diagram. After Row 192 (200) mark each side for setting in sleeves. After Row 218 (226), bind off or remove onto waste yarn, the center 80 sts. for neck. Put the needles on the left into holding position and complete the right side first. *Knit to Row 266 (274) then bind off. Bring the needles on the left into working position, knit 1 row to the left side, turn the Row Counter back to 218 (226) and complete the left half. Follow the instructions from *.



KK 779

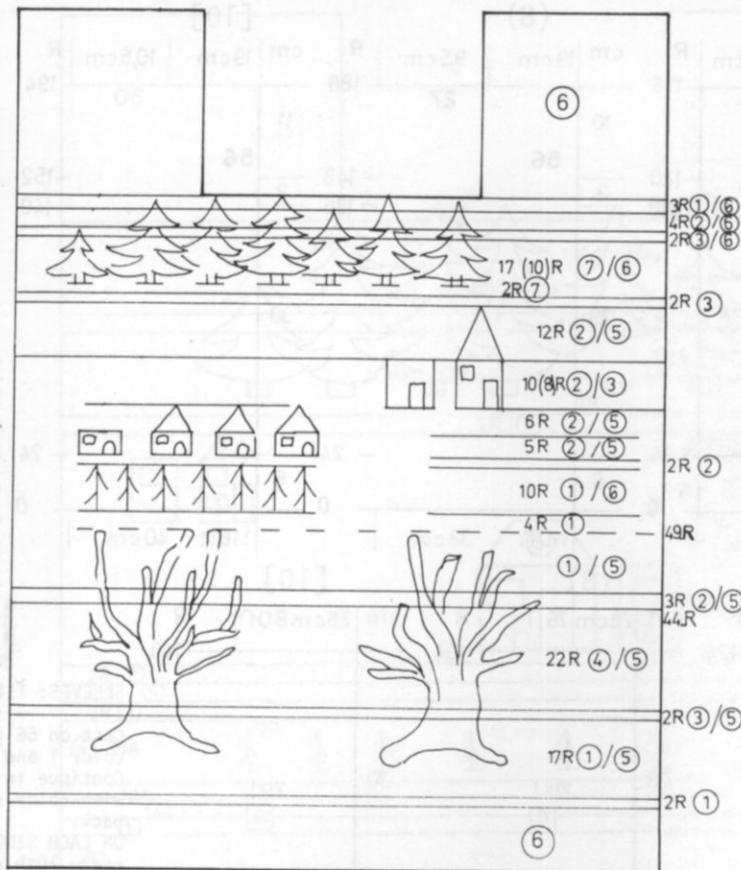
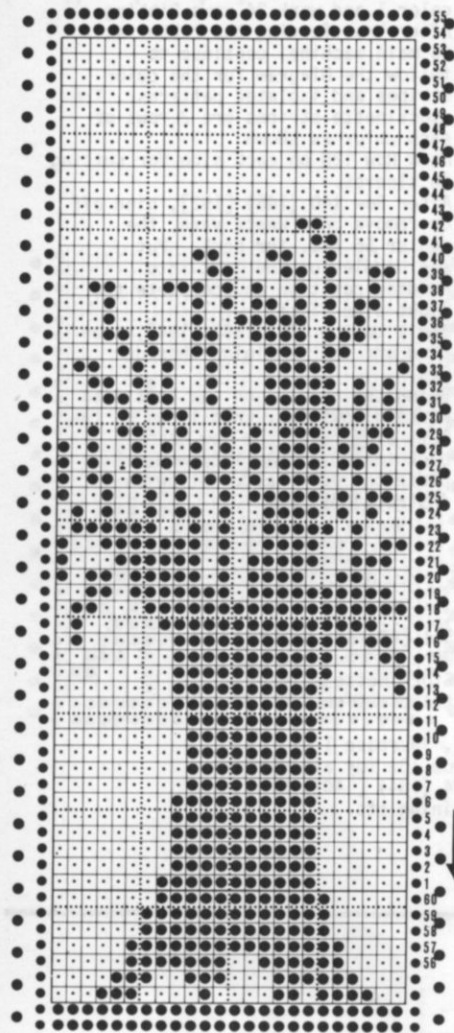

KK 778 / 779

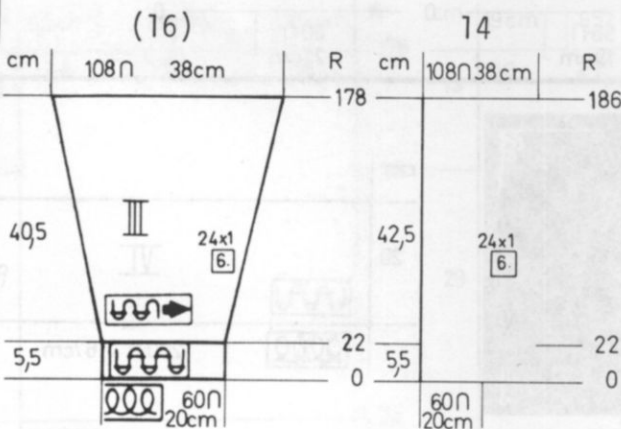
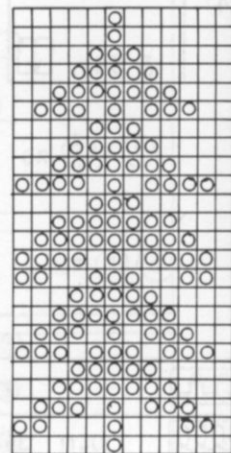

SLEEVES: III

Cast on 60 sts. with color 6 and work 22 rows Ribbing. Continue in Stockinette stitch with color stripes same as front and back. ON EACH SIDE, increase 1 st. every 6th row 24x. After Row 178 (186), bind off.

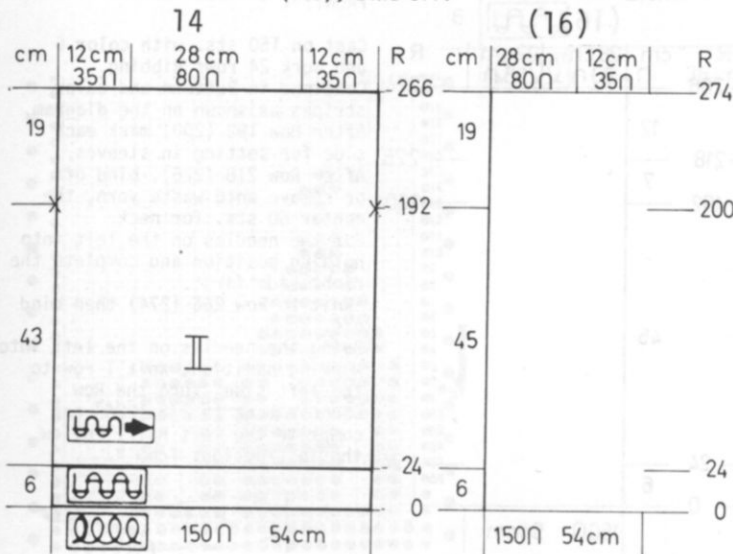

BACK: II

Cast on 150 sts. with color 6 and work 24 rows Ribbing. Continue in Stockinette stitch with color stripes only, same as on the front. After Row 192 (200), mark each side with contrast yarn for setting in sleeves. After Row 266 (274), bind off.

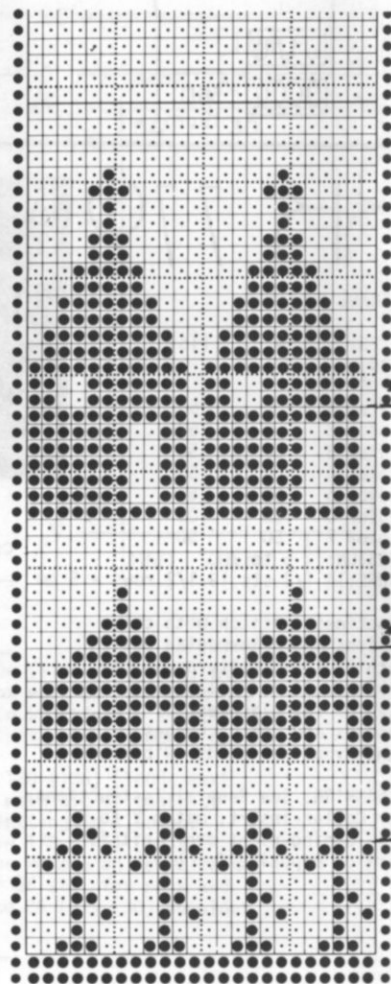

dk 780

WOMAN'S 2 PIECE DRESS

SIZES: 8/10 (12) [14]
 YARN: Vienna & Sewing Thread
 GRAMS: Vienna 800 850 850
 Thread 1 Large Spool for all.
 TENSION: 5 to 7
 GAUGE: 13 1/2 sts. 28 rows = 5 cm (2")

The Skirt is Stockinette stitch with 6 gores. The Top is in Norwegian Technique for 840, 830, 820 machines and Punch Lace for Studio machines. Punch your own card.
 Bands are Stockinette stitch.

FINISHING: See General Instructions. Sew in Bust Dart on Top. Sew open sts. of neckband to neckline, fold in half and sew in place.
 Sew seams of skirt together then fold waistband in half and sew in place. Insert elastic through casing of skirt.

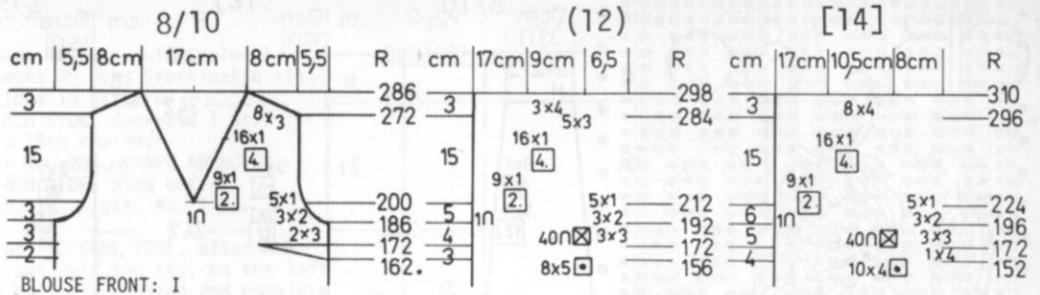
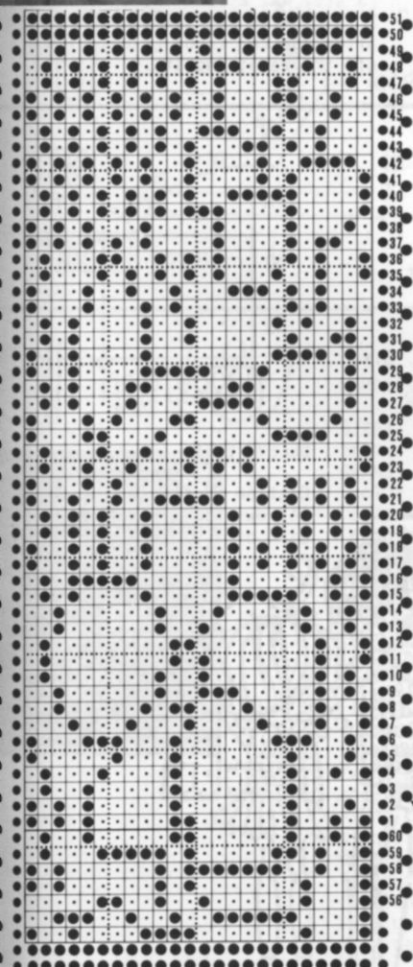

Work the front the same as the back to Row 162 (156) [152]. Mark each side for sewing in the Bust Dart and mark again after Row 172 for all sizes.
 After Row 186 (192) [196], SHAPE ARMHOLE same as the back and after Row 200 (212) [224], transfer the center sts. to a neighboring needle. Put the needles on the left into holding position and complete the right side first.

*ON NECK SIDE, decrease 1 st. every 2nd row 9x, every 4th row 16x for all sizes.
 After Row 272 (284) [296], SHAPE SHOULDER same as the back. Bring the needles on the left into working position, knit 1 row in Pattern to the left side, turn the Row Counter back to 200 (212) [224] and complete the left half. Follow the instructions from *.

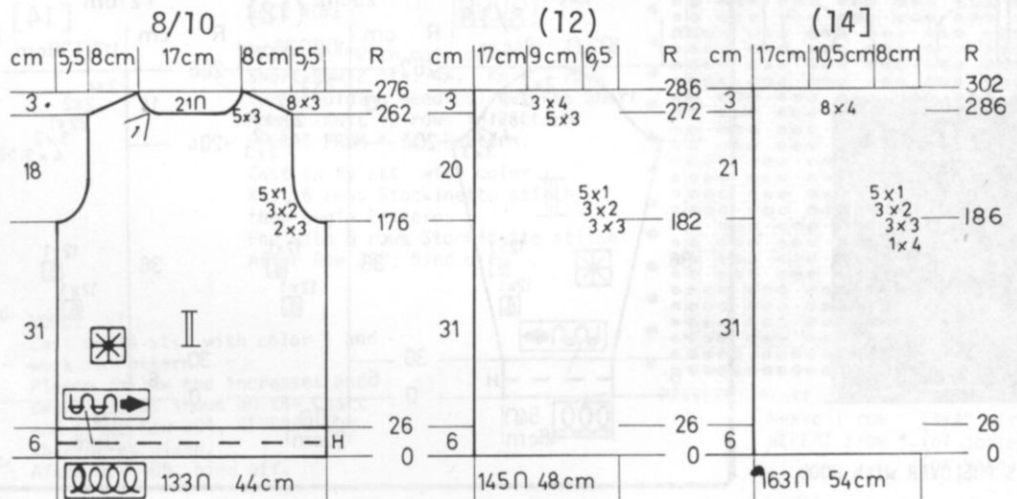

BACK: II

Cast on 133 (145) [163] sts. with color 1 and work 26 rows Stockinette stitch. Hang the hem then continue in Pattern.
 Knit to Row 176 (182) [186].
 SHAPE ARMHOLE: ON EACH SIDE, bind off 3 sts. 2x, 2 sts. 3x, 1 st. 5x. (3 sts. 3x, 2 sts. 3x, 1 st. 5x). [4 sts. 1x, 3 sts. 3x, 2 sts. 3x, 1 st. 5x].
 Knit to Row 262 (272) [286].
 Bind off the center 21 sts. put the needles on the left into holding position and complete the right side first.
 *SHAPE SHOULDER AND NECK AT THE SAME TIME.
 FOR SHOULDER, bind off 3 sts. 8x, (3 sts. 5x, 4 sts. 3x), [4 sts. 8x].
 FOR NECK, bind off 3 sts. 5x for all sizes.
 Bring the needles on the left into working position, knit 1 row in Pattern to the left side, turn the Row Counter back to 262 (272) [286] and complete the left half. Follow the instructions from *.

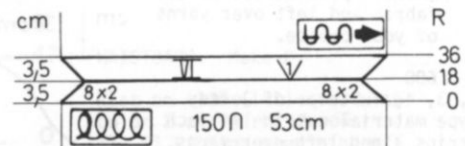

NECKBAND: VI

NOTE: To make the decreases on each side, transfer needles 2 and 3 to 4 and 5. Move end stitch over 1 needle, leave 2nd in working position. Knit to 2 rows.
 To increase, just move end sts. over 1 needle, leave empty needle in working position, knit 2 rows.
 Cast on 150 sts. with color 1 and work Stockinette stitch.
 ON EACH SIDE, decrease 2 sts. every 2nd row 8x.
 After Row 18, ON EACH SIDE, increase 1 st. every 2nd row 8x.
 After Row 36, bind off.



dk 780

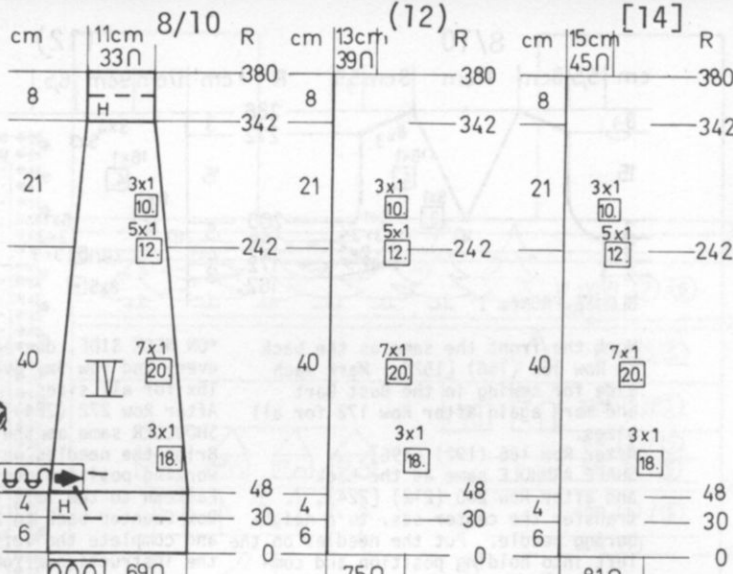

SKIRT: IV Make 6 sections.

Cast on 69 (75) [81] sts. with color 1 and work Stockinette stitch. After Row 48, you can hang the hem if you like.
ON EACH SIDE, decrease 1 st. for all sizes every 18th row 3x, every 20th row 7x, every 12th row 5x, every 10th row 3x.
After Row 342, mark for waist hem or you can hang your cast on comb, knit to Row 380 then hang the hem and bind off.

dk 781

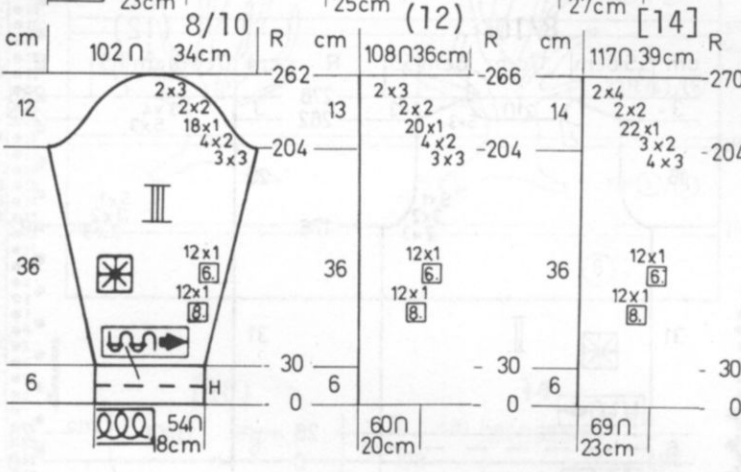

SLEEVES: II

Cast on 54 (60) [69] sts. with color 1 and work 26 rows Stockinette stitch. Hang the hem then continue in Pattern.
ON EACH SIDE, increase 1 st. every 8th row 12x, every 6th row 12x for all sizes.
After Row 204 SHAPE CAP: ON EACH SIDE, bind off 3 sts. 3x, 2 sts. 4x, 1 st. 18x, 2 sts. 2x, 3 sts. 2x. (3 sts. 3x, 2 sts. 4x, 1 st. 20x, 2 sts. 2x, 3 sts. 2x). [3 sts. 4x, 2 sts. 3x, 1 st. 22x, 2 sts. 2x, 4 sts. 2x].
After Row 262 (266) [270], bind off the remaining sts.

WOMAN'S PULLOVER with HOOD

SIZES: Small/Medium (one size)
YARN: Amore - plus strips of cut fabric and left over yarns of your choice.
GRAMS: color 1 600
color 2, 3, 4, - Strips of Jersey type material cut in 1/4 inch strips - and left over yarns.
TENSION: 7 to 9
GAUGE: 14 sts. 21 rows = 5 cm (2")

A Weaving Pattern. Punch your own Card. The Hood is lined with Stockinette stitch or you can line it with fabric if you prefer. Sleeve Cuffs are K1, P1 Ribbing.

FINISHING: Sew around all sections with sewing machine using a zig-zag stitch then cut the edges of weaving threads. Sew all seams with sewing machine. Sew lining to hood with right sides together leaving an opening. Turn to the right side and close opening. Pull cord through.

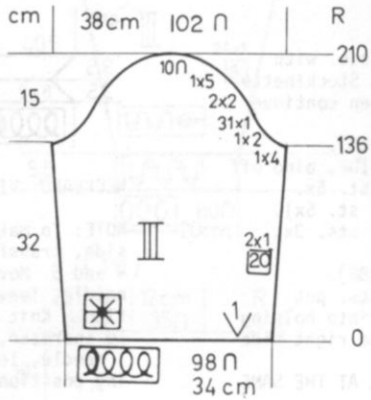

SLEEVES: III

Cast on 98 sts. with color 1 and work in Pattern.
ON EACH SIDE, increase 1 st. every 20th row 2x.
After Row 136 SHAPE CAP: ON EACH SIDE, bind off 4 sts. 1x, 2 sts. 1x, 1 st. 31x, 2 sts. 2x, 5 sts. 1x.
After Row 210, bind off the remaining sts.

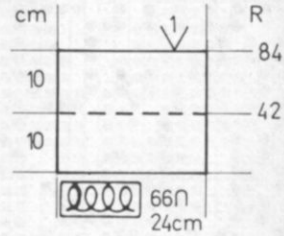

SLEEVE CUFF:

Cast on 66 sts. and work 84 rows K1, P1 Ribbing then bind off.

FRONT: I

The front is worked the same as the back to Row 204.
SHAPE ARMHOLE same as the back BUT AT THE SAME TIME, after Row 228, SHAPE NECK: Put half the sts. on the left into holding position and complete the right side first.
*ON NECK SIDE, bind off 10 sts. 1x, 6 sts. 1x, 5 sts. 1x, 4 sts. 2x, 3 sts. 8x.
Bring the needles on the left into working position, knit 1 row in Pattern to the left side, turn the Row Counter back to 228 and complete the left half. Follow the instructions from *.



SMALL/MEDIUM

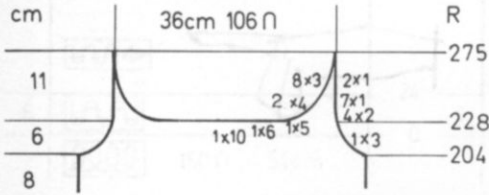

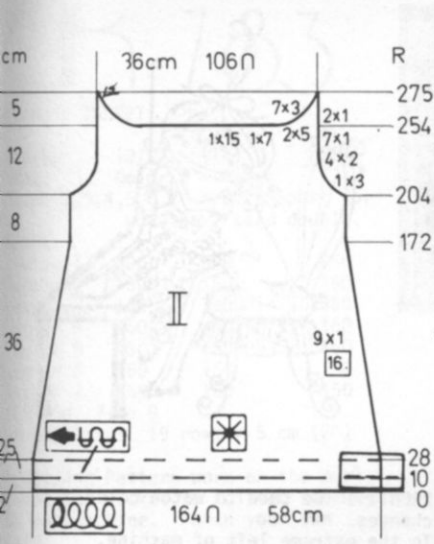

BACK: II
 Cast on 164 sts. with color 1 and work 28 rows Stockinette stitch. Continue in Pattern.
 ON EACH SIDE, decrease 1 st. every 16th row 9x.
 After Row 204, SHAPE ARMHOLE:
 ON EACH SIDE, bind off 3 sts. 1x, 2 sts. 4x, 1 st. 7x, 1 st. 2x,
 BUT AT THE SAME TIME, after Row 254, put half the sts. on the left into holding position and complete the right side first.
 *ON NECK SIDE, bind off 15 sts. 1x, 7 sts. 1x, 5 sts. 2x, 3 sts. 7x. After Row 275, this side is completed.
 Bring the needles on the left into working position, knit 1 row in Pattern to the left side, turn the Row Counter back to 254 and complete the left half. Follow the instructions from *.

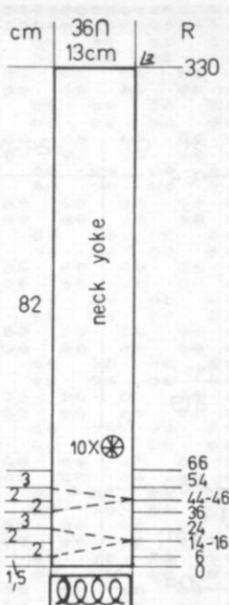

NECK YOKE:

PATTERN: *With main color Short Row 2 sts. 4x, Knit 3 rows (wrap holding needles) REVERSE Short Rows. Knit 12 rows in Pattern. REPEAT FROM * for Pattern.
 Cast on 36 sts. with color 1. Knit 6 rows Stockinette stitch then begin Pattern. End with 6 rows Stockinette stitch. After Row 330, bind off.

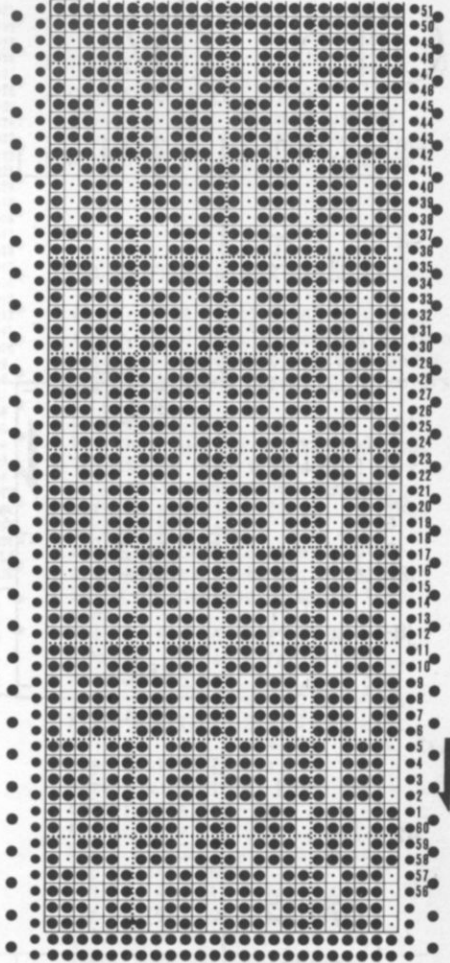

PATTERN: *Knit 2 rows Weave 1 row (1/4" strips REPEAT from * (of jersey (or yarn)

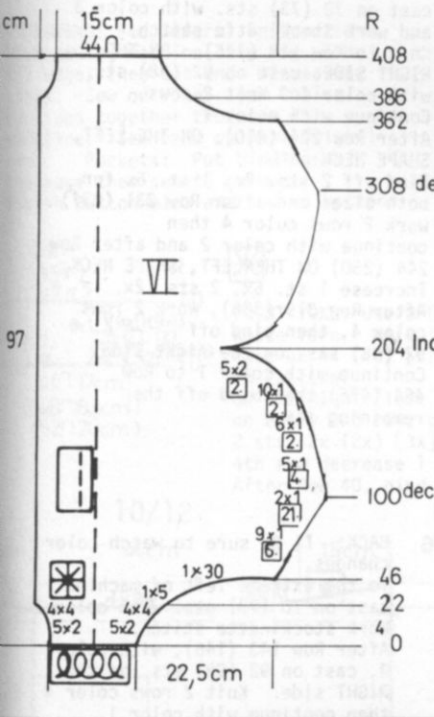

HOOD: VI
 Cast on 44 sts. with color 1 and work in Pattern. Please follow the increases and decreases as shown on the Chart and after Row 204, REVERSE the shaping as given. After Row 408, bind off.

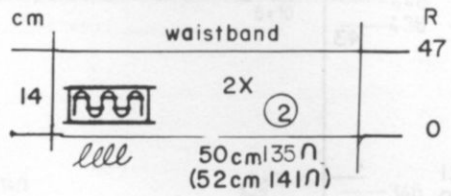

WAISTBAND: Make 2.

Cast on 135 (141) sts. with color 2 and work 47 rows K1, P1 Ribbing then bind off.

DK 782

WOMAN'S PULLOVER

SIZES: 8/10 (12/14)
 YARN: Euro Sport
 GRAMS:
 color 1 * 200 250
 color 2 200 250
 color 3 200 250
 color 4 50 50
 TENSION: 6 to 8
 GAUGE: 13 1/2 sts. 17 rows = 5 cm (2")

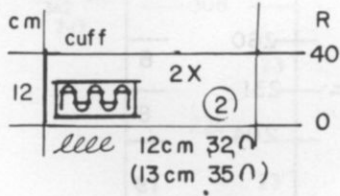

CUFF: Make 2.

Cast on 32 (35) sts. with color 2 and work 40 rows K1, P1 Ribbing then bind off.

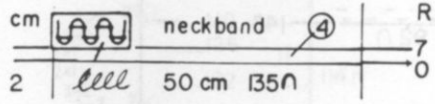

NECKBAND:

Cast on 135 sts. with color 4 and work 7 rows K1, P1 Ribbing. Remove the sts. onto waste yarn and attach to neckline by hand through the open sts.



Stockinette stitch knitted sideways on the machine. Bands are ribbed.

FINISHING: With right side facing, work 1 row double crochet along shoulder and sleeve edges of front section. With right sides together, put back section to front along the double crochet with a slip stitch. Double up the sts. on sleeve edge for cuff. Follow Chart - knit last row loosely and latch bind off. Pick up sts. on lower edge and make waist band - see Chart.

DK 782

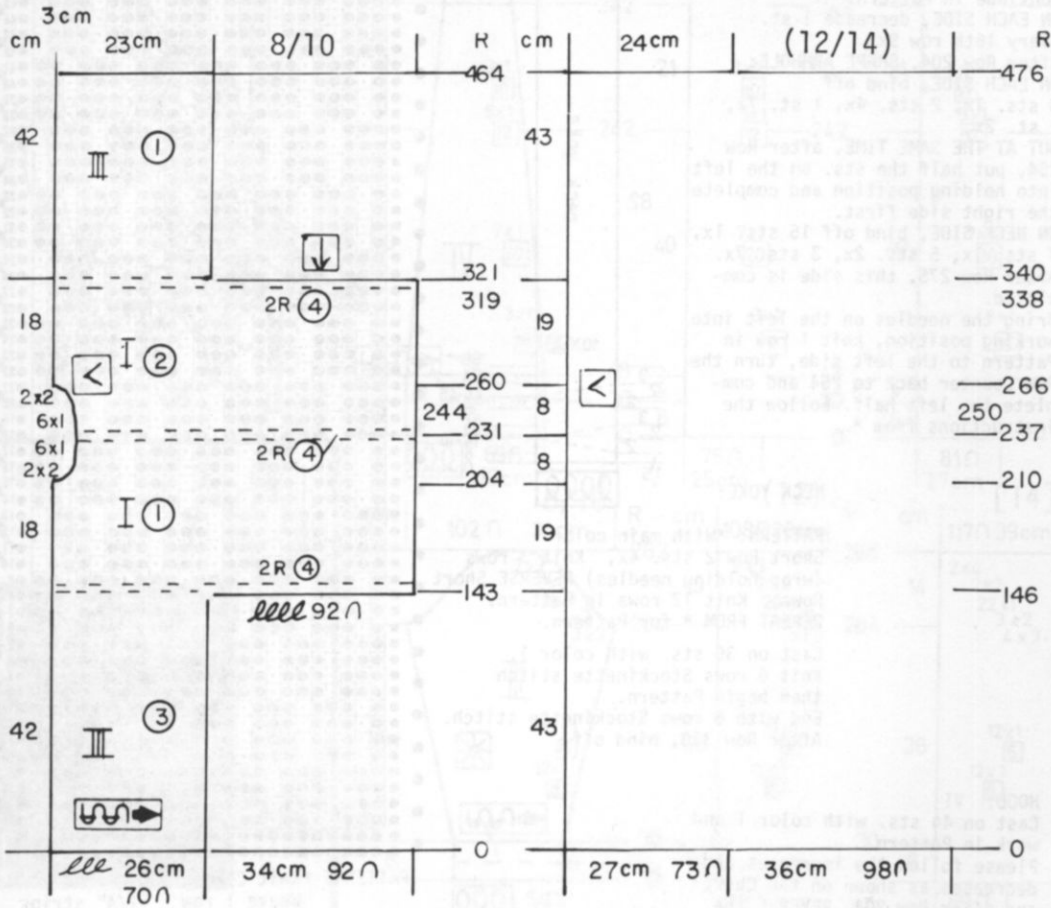

FRONT: I Be sure to watch color changes. To the extreme left of machine, cast on 70 (73) sts. with color 3 and work Stockinette stitch. Knit to Row 143 (146). ON THE RIGHT SIDE, cast on 92 (98) sts. with color 4. Knit 2 rows. Continue with color 1. After Row 204 (210), ON THE LEFT, SHAPE NECK: Bind off 2 sts. 2x, 1 st. 6x for both sizes and after Row 231 (237) work 2 rows color 4 then continue with color 2 and after Row 244 (250) ON THE LEFT, SHAPE NECK: Increase 1 st. 6x, 2 sts. 2x. After Row 319 (338), work 2 rows color 4, then bind off 92 (98) sts. on the right side. Continue with color 1 to Row 464 (476) then bind off the remaining sts.

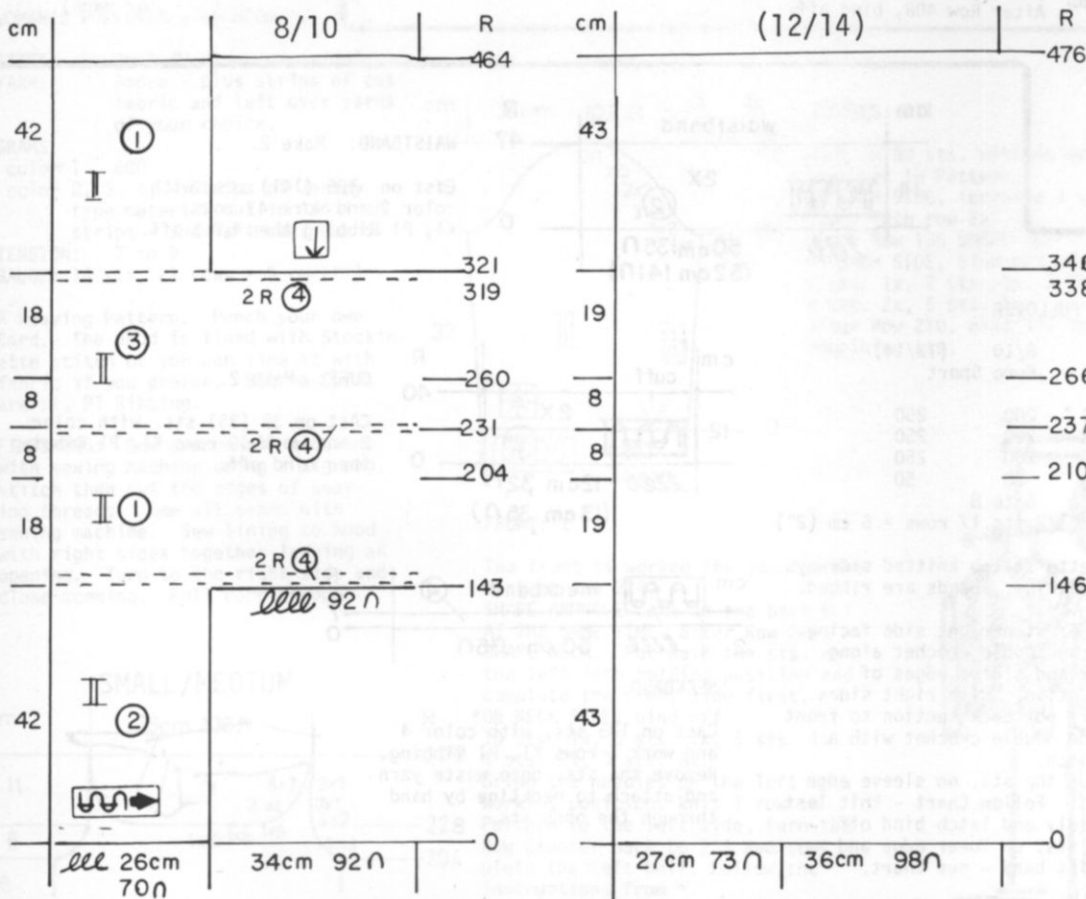

BACK: II Be sure to watch color changes. To the extreme left of machine cast on 70 (73) sts. with color 2. Work stockinette stitch. After Row 143 (146), with color 4, cast on 92 (98) sts. on the RIGHT side. Knit 2 rows color 4 then continue with color 1. Mark Row 204 (210) on the left for neck. After Row 231 (237), work 2 rows color 4, then continue with color 3. Mark Row 260 (266) on the left side for neck. After Row 319 (338), work 2 rows color 4. After Row 321 (340), bind off 92 (98) sts. on the RIGHT side and continue with color 1. Knit to Row 464 (476) then bind off the remaining sts.

DK 783

WOMAN'S JACKET

SIZES: 10/12 (14) [16]
 YARN: Color 1 = Amore
 Color 2,3,4,5,6,7 = Euro Sport for
 weaving - used double.

GRAMS:

color 1	600	600	650
color 2	150	150	150
color 3	150	150	150
color 4	150	150	150
color 5	150	150	150
color 6	150	150	150
color 7	150	150	150

TENSION: 7 to 9
 GAUGE: 13 sts. 19 rows = 5 cm (2")

A Weaving Pattern worn on the purl side. The Jacket is knitted sideways on the machine. Punch your own Card.

FINISHING: See General Instructions.
 With sewing machine, zig zag along all edges then cut ends of weaving yarns. Sew on Yokes. Sew Collar sections together then sew to neckline. Sew band on purl (right) side. Pockets: Put binding on top edge then sew to garment. Finish Buttonholes and sew on buttons.

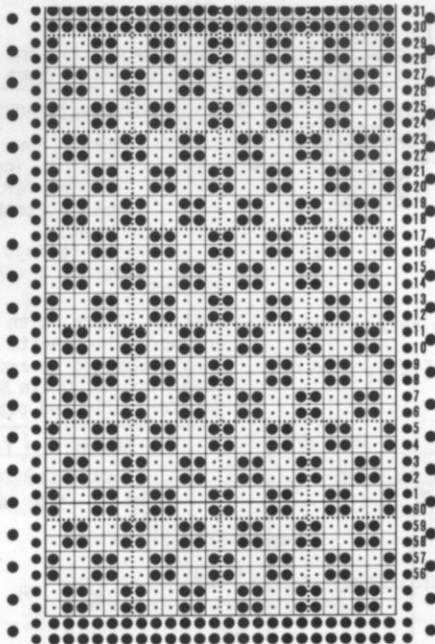

PATTERN:

6 Rows Stockinette stitch
 2 Rows Weaving. You must use a different color for EACH WEAVING ROW then REPEAT the color sequence.

JACKET FRONT & BACK:

Cast on 154 (154) [156] sts. with color 1 and work in Weaving Pattern of 6 rows Stockinette stitch and 2 rows of Weaving changing the colors as given.

Work Short Rows.
 Put into holding position all but 10 sts. on the right side. Work in Pattern and bring back into working position, 10 sts. 5x then 94 (94)[96] sts.

Work BUTTONHOLES after Row 20 over needles 21 to 25, 28 to 32, 55 to 59 counting from the left edge.

Knit to Row 96 (102) [108]. SHAPE ARMHOLE the same for all sizes. Bind off 26 sts. then bind off 3 sts. 2x, 2 sts. 3x, 1 st. 2x. After Row 120 (126) [136], cast on 1 st. 2x, 2 sts. 3x, 3 sts. 2x, then cast on 26 sts.

Mark row 212 (224) [236] for center back.

Knit to Row 290 (308) [328]. SHAPE ARMHOLE the same as you did before, then

knit to Row 412 (436) [460].

Put 94 (94) [96] sts. into holding position on the left side, then put into holding position 10 sts. 6x (for all sizes).

After Row 424 (448) [472], bring all the needles into working position and bind off.

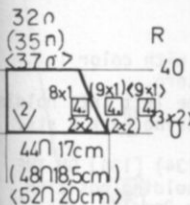

FRONT YOKE: Use OPEN CAST ON with Waste Yarn. Make 1, reverse 1. Cast on 44 (48) [52] sts. and work in Pattern.
 ON THE RIGHT (left for 2nd section), on every 2nd row, bind off 2 sts. 2x (2x) [3x] then on every 4th row decrease 1 st. 8x (9x) [9x]. After Row 40, bind off.

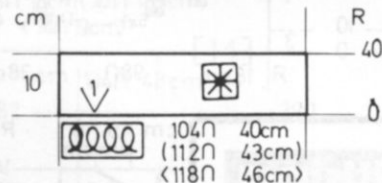

BACK YOKE: Use OPEN CAST ON with waste yarn. Cast on 104 (112) [118] sts. with color 1 and work in Pattern. After Row 40, bind off.

10/12

(14)

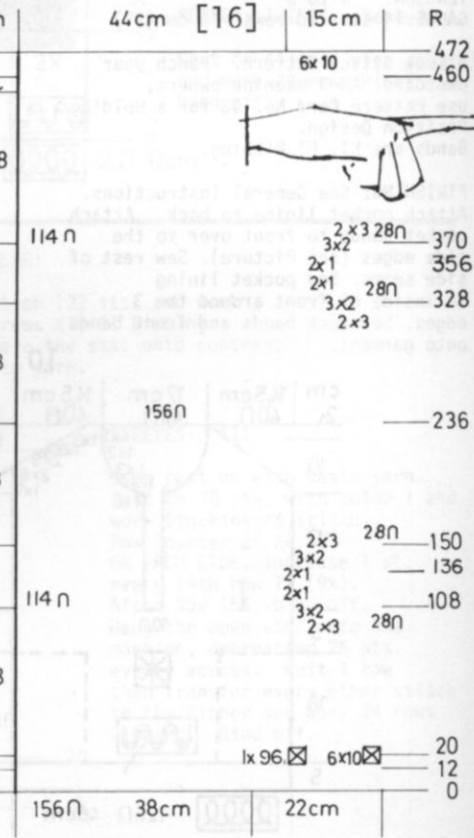
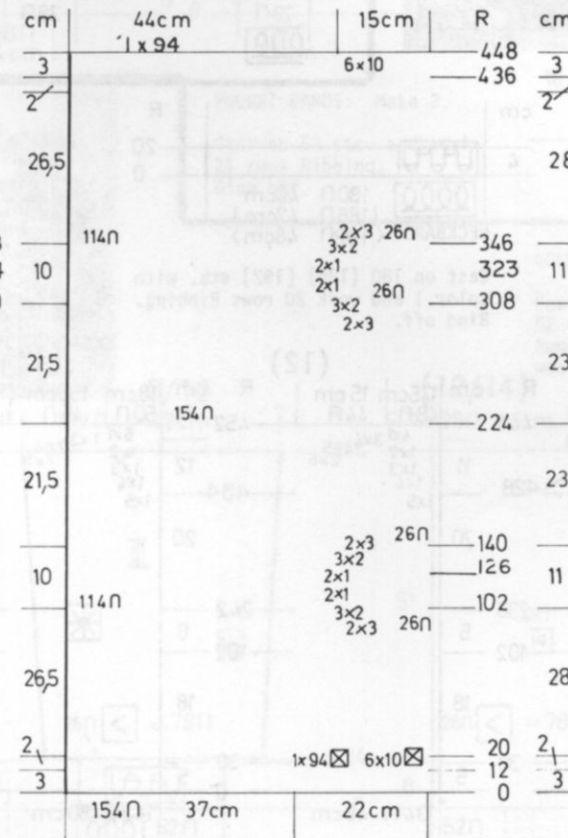
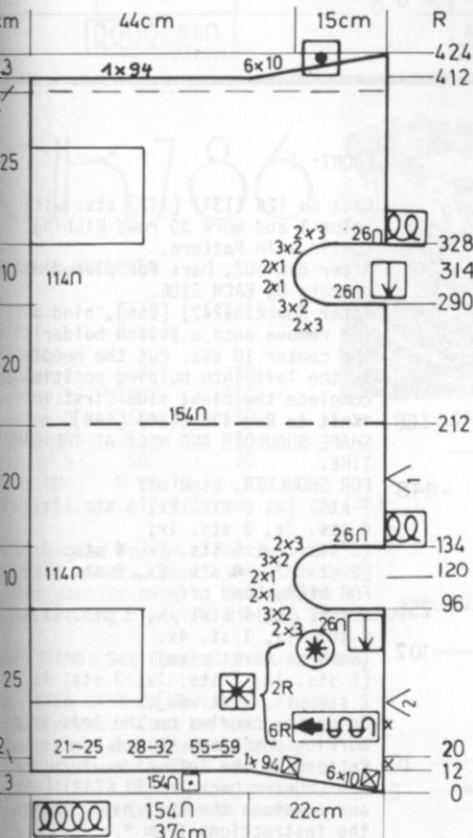

DK 786

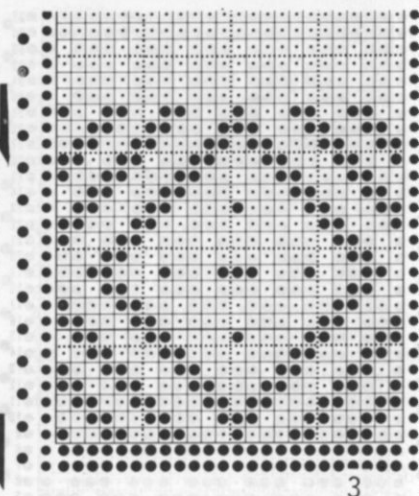
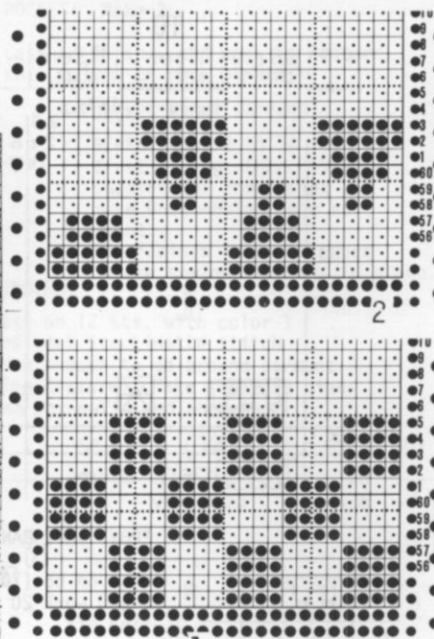
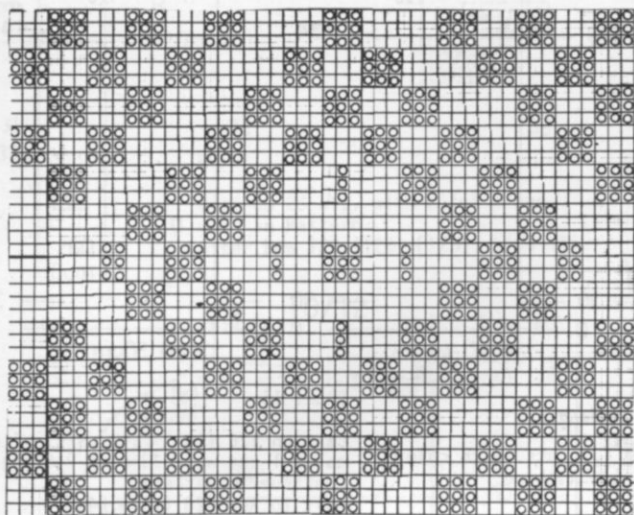

The Norwegian Design is only on the front section and the listed Pattern sequence will complete the necessary rows for the front. They are as follows: Begin with STRIPES: - 2 rows color 1, 6 rows color 2, 4 rows color 4, 2 rows color 2, 4 rows color 3, 4 rows color 2, 2 rows color 1, 2 rows color 2, 2 rows color 4, 6 rows color 3, 8 rows color 2, 10 rows color 1. 12 Rows Pattern No. 1, changing color every 4 rows. Work Stripes - 10 rows color 1, 2 rows color 2, 4 rows color 3, 4 rows color 2, 2 rows color 4, 2 rows color 2, 6 rows color 3, 4 rows color 2, 2 rows color 4, 2 rows color 2, 4 rows color 1, 4 rows color 3, 4 rows color 2. 10 rows Pattern No. 2. 6 rows color 2. Pattern No. 3 - ELONGATE CARD or follow Line Drawing. STRIPES: 6 rows color 2, 2 rows color 4, 2 rows color 2, 4 rows color 3, 2 rows color 2, 2 rows color 1, 4 rows color 2, 2 rows color 3, 18 rows color 2.

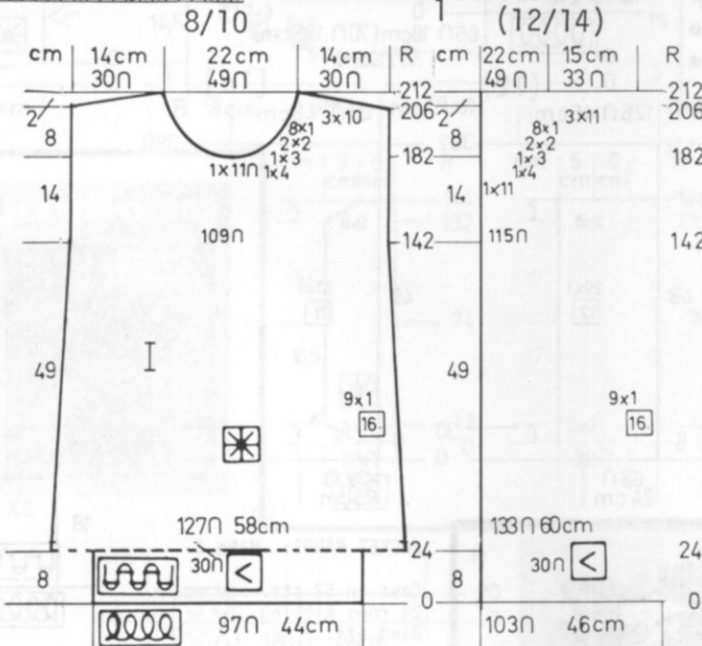

FRONT: I

Open cast on with waste yarn. Cast on 127 (133) sts. Put Counter at 24 and work in Pattern. ON EACH SIDE, decrease 1 st. every 16th row 9x. Mark Row 142 on each side for setting in sleeves. Knit to Row 182. Bind off the center 11 sts., put the needles on the left into holding position and complete the right side first. *ON NECK SIDE, bind off 4 sts. 1x, 3 sts. 1x, 2 sts. 2x, 1 st. 8x. After Row 206, SHAPE SHOULDER: Bind off 10 sts. 3x, (11 sts. 3x). Bring the needles on the left into working position, knit 1 row in Pattern to the left side, turn the Row Counter back to 182 and complete the left half. Follow the instruction from *.

Hang the open sts. held on waste yarn back onto the machine, decreasing 30 sts. evenly across. Knit 1 row stockinette stitch then transfer every other stitch to the ribber and work 24 rows Ribbing.

BACK: II

Open cast on with waste yarn. Cast on 127 (133) sts. with color 1. Row Counter 24. Work Stockinette stitch. ON EACH SIDE, decrease 1 st. every 16th row 9x. Mark Row 142 ON EACH SIDE for setting in sleeves. Knit to Row 206. Bind off the center 41 sts., put the needles on the left into holding position and complete the right side first. *SHAPE SHOULDER AND NECK AT THE SAME TIME. FOR SHOULDER, bind off 10 sts. 3x, (11 sts. 3x), FOR NECK, bind off 2 sts. 2x. Bring the needles on the left into working position, knit 1 row to the left side, turn the Row Counter back to 206 and complete the left half. Follow the instructions from *.

Hang the open sts. held on waste yarn onto the machine, decreasing 30 sts. evenly across. Knit 1 row, then transfer every other stitch to the ribber and work 24 rows Ribbing. Bind off.

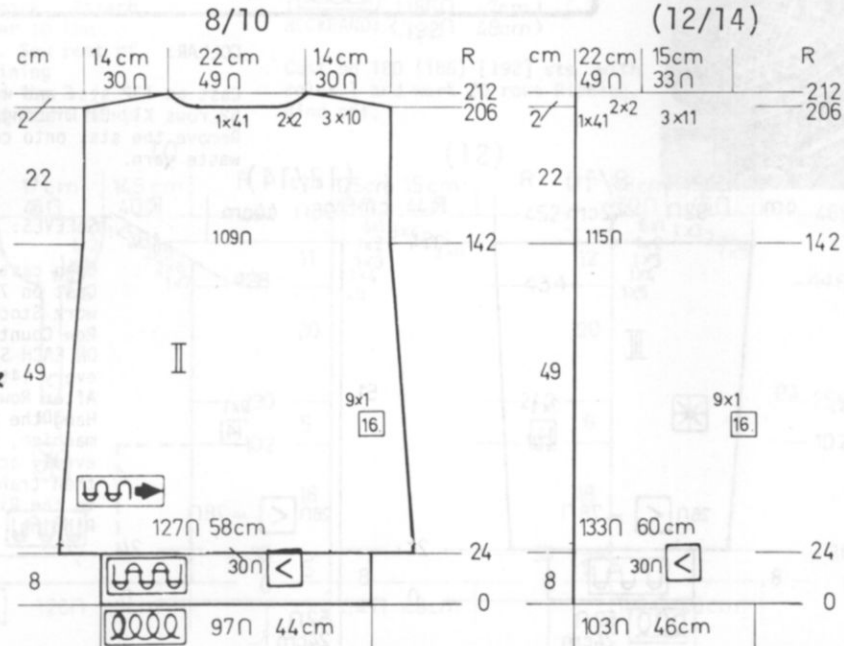

DK 787

WOMAN'S HAT, SCARF, LEGGINGS & PULLOVER

- SIZES: 8/10 (12/14)
 YARN: Euro Sport
 PULLOVER
 color 1 500 550
 color 2 450 500
 Hat 100 - color 1
 Scarf 150 - color 1
 LEGGINGS
 color 1 300
 color 2 200
 TENSION: 9 or 10
 GAUGE: 13 sts. 14 rows = 5 cm (2")



PUNCH CARD for DK 787 is on Page 45

Norwegian Design with Ribbed bands. The Scarf is ribbed. Hat is Stockinette stitch. Punch your own Card and follow the Chart.

FINISHING: See General Instructions. Make fringe for ends of Scarf. Cut yarn 17 cm long and use 2 strands for each fringe.

OPEN CAST ON for Pullover, and sleeves. Cast on with contrast waste yarn, knit 8 to 10 rows (last row with Ravel Cord). Change to Garment yarn and put Counter at stated Row. The open sts. will be picked up later for the Ribbing.

COLLAR: Cast on 164 sts. with color 1 and work 56 rows K1, P1 Ribbing. Bind off.

HAT: Cast on 84 sts. with color 1 and work Stockinette stitch. After Row 40, work the 4 sections separately - 21 sts. for each section and follow the decreases as shown on the Chart. After Row 82, remove the sts. onto strand of yarn. Use the same strand of yarn to take off each section so you can pull it up and secure. Sew up all seams.

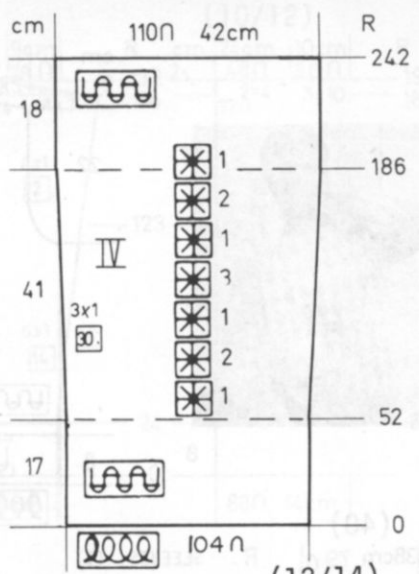

LEGGINGS: Make 2.
Cast on 104 sts. with color 1 and work 52 rows K1, P1 Ribbing. Continue in REPEATED Norwegian Design with colors 2 & 3 and ON EACH SIDE, increase 1 st. every 30th row 3x. After Row 186, continue in K1, P1 Ribbing with color 1 to Row 242. Bind off.

FRONT: I

Work the front the same as the back to Row 219. Bind off the center 20 sts. put the needles on the left into holding position and complete the right side first. *ON NECK SIDE, for both sizes, bind off 4 sts. 1x, 3 sts. 2x, 2 sts. 3x. Bind off the remaining sts. Bring the needles on the left into working position, knit 1 row in Pattern to the left side, turn the Row Counter back to 219 and complete the left half. Follow the instructions from *.

Hang the open sts. held on waste yarn onto the machine, decreasing to 110 (122) sts. With color 1 work 24 rows K1, P1 Ribbing then bind off.

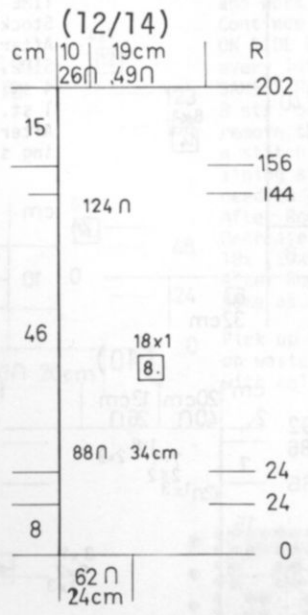
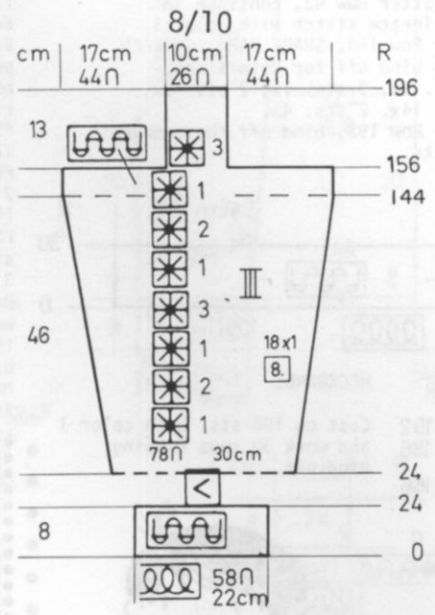
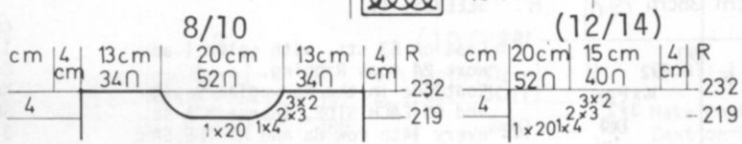

SLEEVES: III

OPEN CAST ON WITH WASTE YARN. Cast on 78 (88) sts. and put Counter at 24. Work the REPEATED Norwegian Design with color 2 and 3 and ON EACH SIDE, increase 1 st. every 8th row 18x. After Row 144, Continue in K1, P1 Ribbing with Color 1. After Row 156, ON EACH SIDE, bind off 44 sts. Knit to Row 196 (202) then bind off.

Hang the open sts. held on waste yarn back onto the machine, decreasing to 58 sts. With color 1 work 24 rows Ribbing. Bind off.

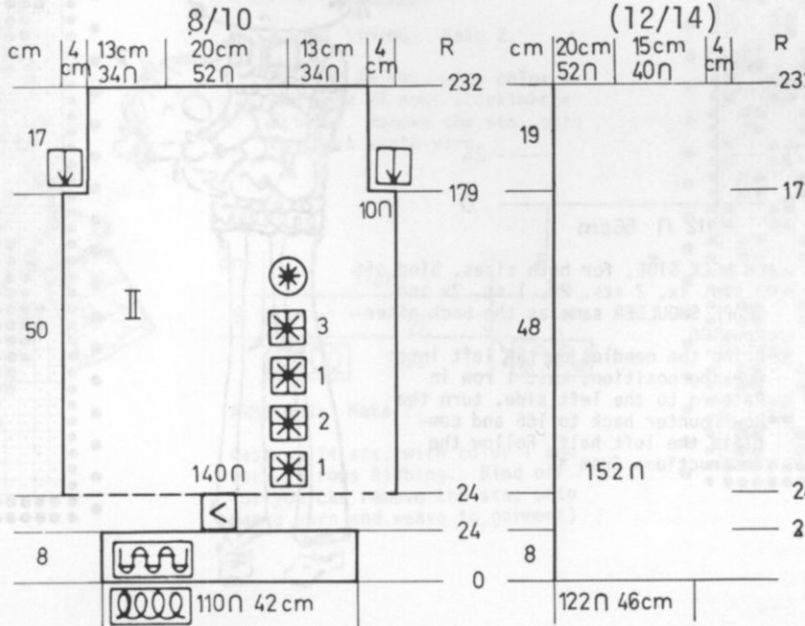

BACK: II

OPEN CAST ON WITH WASTE YARN. Cast on 140 (152) sts. and put Counter at 24. Work the REPEATED Norwegian Design with colors 2 and 3. Knit to Row 179 (173). ON EACH SIDE, bind off 10 sts. Knit to Row 232 then bind off.

Hang the open sts. held on waste yarn onto the machine, decreasing to 110 (122) sts. With color 1, work 24 rows K1, P1 Ribbing, then bind off.

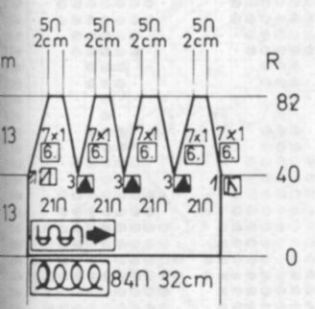

hp 700

MAN'S PULLOVER

SIZES: 38 (40)
 YARN: Euro Sport
 GRAMS:
 color 1 500 550
 color 2 150 200
 TENSION: 8 to 10
 GAUGE: 10 sts. 15 rows = 5 cm (2")

Stockinette stitch with a Norwegian Design on front and lower sleeves.
 Bands are K2, P2 or K1, P1 Ribbing.
 Punch your own Card for the Norwegian Design.

FINISHING: See General Instructions.

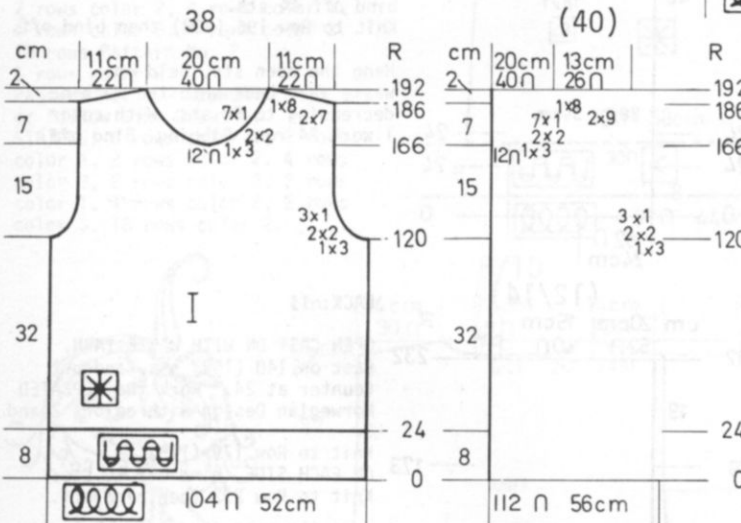
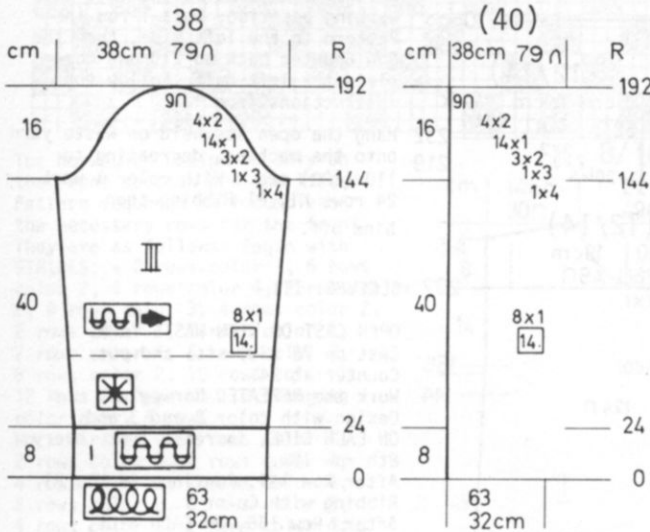
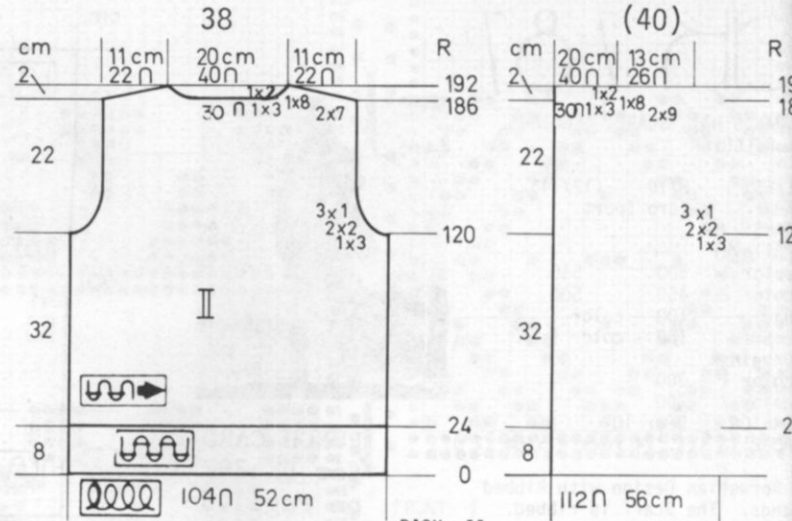

FRONT: I

Cast on 104 (112) sts. with color 1 and work 24 rows Ribbing.
 Continue in the Norwegian Design.
 Knit to Row 120.
 SHAPE ARMHOLE: ON EACH SIDE, bind off 3 sts. 1x, 2 sts. 2x, 1 st. 3x. (Same as first size).
 Knit to Row 166.
 Bind off the center 12 sts., put the needles on the left into holding position and complete the right side first.

*ON NECK SIDE, for both sizes, bind off 3 sts. 1x, 2 sts. 2x, 1 st. 7x and SHAPE SHOULDER same as the back after Row 186.
 Bring the needles on the left into working position, knit 1 row in Pattern to the left side, turn the Row Counter back to 166 and complete the left half. Follow the instructions from *.

SLEEVES: III

Cast on 63 sts. with color 1 and work 24 rows Ribbing.
 Continue in the Norwegian Design and ON EACH SIDE, increase 1 st. every 14th row 8x and AT THE SAME TIME after Row 42, continue in Stockinette stitch with color 1.
 After Row 144, SHAPE CAP: ON EACH SIDE, bind off for both sizes, 4 sts. 1x, 3 sts. 1x, 2 sts. 3x, 1 st. 14x, 2 sts. 4x.
 After Row 192, bind off the remaining sts.

BACK: II

Cast on 104 (112) Sts. with color 1 and work 24 rows Ribbing.
 Continue in Stockinette stitch.
 Knit to Row 120.
 SHAPE ARMHOLE: ON EACH SIDE, bind off 3 sts. 1x, 2 sts. 2x, 1 st. 3x. (3 sts. 1x, 2 sts. 2x, 1 st. 3x).
 Knit to Row 186.
 Bind off the center 30 sts., put the needles on the left into holding position and complete the right side first.

*SHAPE SHOULDER AND NECK AT THE SAME TIME.

FOR SHOULDER, bind off

7 sts. 2x, 8 sts. 1x,

(9 sts. 2x, 8 sts. 1x),

FOR NECK, bind off for both

sizes,

3 sts. 1x, 2 sts. 1x.

Bring the needles on the left into

working position, knit 1 row to

the left side, turn the Row Counter

back to 186 and complete the left

half. Follow the instructions

from *.

NECKBAND:

Cast on 108 sts. with color 1 and work 30 rows Ribbing.
 Bind off.

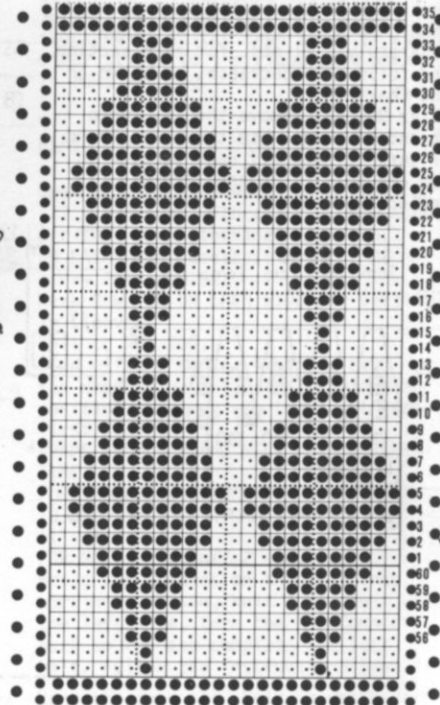

DK 789

WOMAN'S VEST

SIZES: 8 (10/12)
YARN: Euro Sport
GRAMS:
 color 1 400 450
 color 2 100 100
TENSION: 8 to 10
GAUGE: 10 sts. 15 rows = 5 cm (2")

Norwegian Design on the front section only. Punch your own card. The back is Stockinette st. Bands are K2, P2 or K1, P1 Ribbing.

FINISHING: See General Instructions. Sew on front and arm bands, turn to the inside and sew in place. Sew pocket lining down on the inside. Finish buttonholes and sew on buttons.



FRONT BANDS: Make 2

Cast on 200 sts. with color 1 and work in Ribbing. After Row 6, MAKE BUTTONHOLES, over needles 7 to 10, 31 to 34, 55 to 58, 79 to 82, counting from the LEFT edge. After Row 18, work BUTTONHOLES over the same needles. After Row 24, bind off.
 Omit buttonholes on second piece.

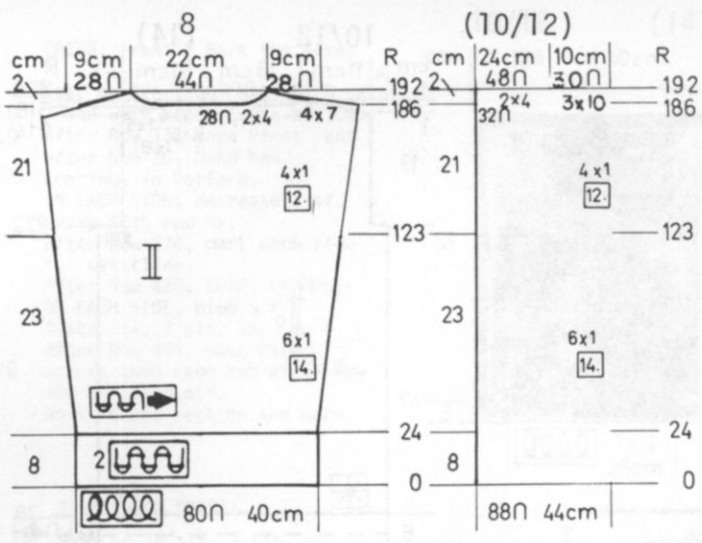

BACK: II
 Cast on 80 (88) sts. with color 1 and work 24 rows Ribbing. Continue in Stockinette stitch. ON EACH SIDE, increase 1 st. every 14th row 6x.
 Mark Row 123 for sewing on bands. ON EACH SIDE, increase 1 st. every 12th row 4x.
 After Row 186, bind off the center 28 (32) sts., put the needles on the left into holding position and complete the right side first. SHAPE SHOULDER AND NECK AT THE SAME TIME.
 *FOR SHOULDER, bind off 7 sts. 4x, (10 sts. 3x),
 FOR NECK, bind off for both sizes, 4 sts. 2x.
 Bring the needles on the left into working position, knit 1 row to the left side, turn the Row Counter back to 186 and complete the left half. Follow the instructions from *.

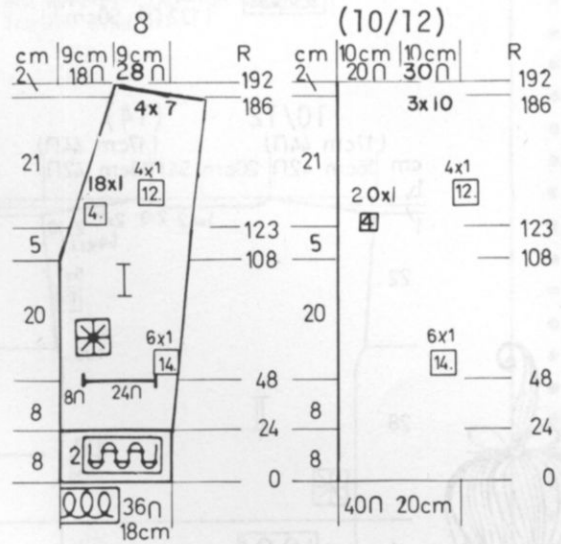

FRONT: I Make 1, reverse 1
 Make Pocket lining first. Cast on 36 (40) sts. with color 1 and work 24 rows Ribbing. Continue in the Norwegian Design. ON SIDE EDGE, increase 1 st. every 14th row 6x, BUT AT THE SAME TIME, after Row 48, leave 8 sts. on the front edge, then remove the next 24 sts. onto a stitch holder. Hang the pocket lining sts. onto the empty needles and continue in Pattern. After Row 108, SHAPE NECK: Decrease 1 st. every 4th row 18x (20x). After Row 186, SHAPE SHOULDER same as the back.
 Pick up the sts. of pocket held on waste yarn. Work 8 rows Ribbing with color 1, bind off.

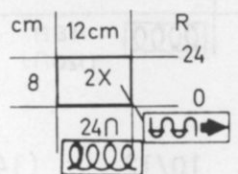

POCKET LINING: Make 2.

Cast on 24 sts. with color 1 and work 24 rows Stockinette stitch. Remove the sts. onto contrast waste yarn.

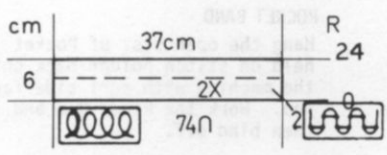

ARMBANDS: Make 2.

Cast on 74 sts. with color 1 and work 24 rows Ribbing. Bind off (or you can remove the sts. onto waste yarn and weave to garment)

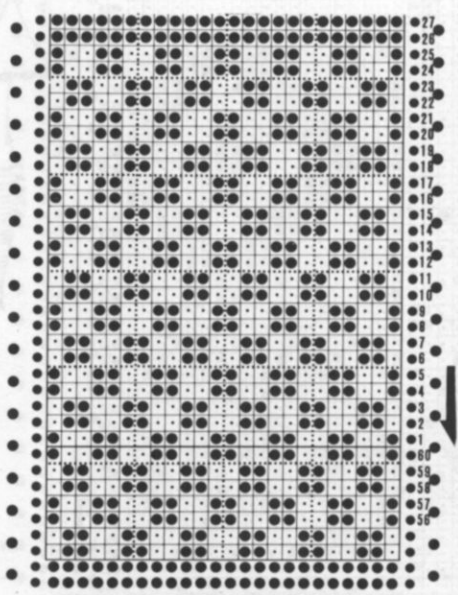

DK 790

WOMAN'S DRESS, PULLOVER & JACKET

SIZES: 10/12 (14)
 YARN: Vienna
 GRAMS:
 color 1 500 550
 color 2 500 500
 TENSION: 5 to 7
 GAUGE: 13 sts. 22 rows = 5 cm (2")



Stockinette stitch with an Eyelet Design. Punch your own Card. Pullover bands are K2, P2 or K1, P1 Ribbing. Bands for Jacket and Dress have a Picot Hem.

FINISHING: See General Instructions. Make 2 Monks Cords and pull one through neckline of Jacket and one goes around the waist of Pullover. Sew pocket lining down on the inside.

PICOT HEMS:
 After Row 13, transfer every other stitch to neighboring needle, leave empty needle in work and continue knitting to Row 26 then hang the hem. Continue as instructions given.

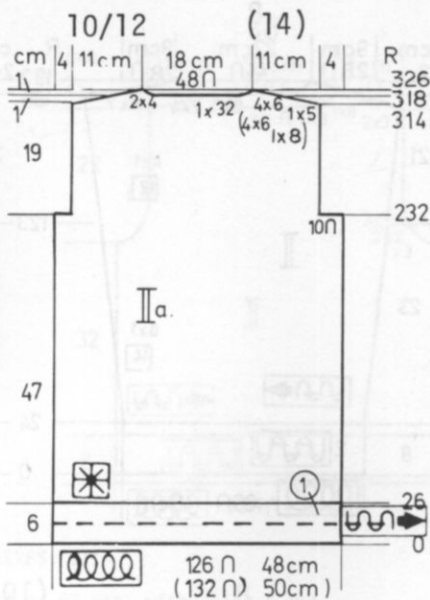
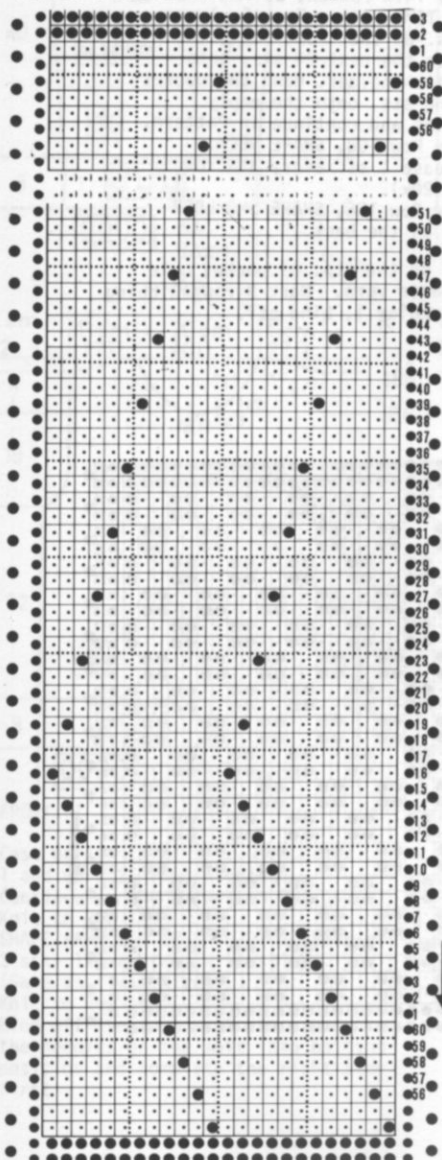

JACKET BACK: II

Cast on 126 (132) sts. with color 1 and work the Picot Hem same as you did for Dress. Continue in Pattern with color 2. Knit to Row 232. SHAPE ARMHOLE: ON EACH SIDE, bind off 10 sts. Knit to Row 314. SHAPE SHOULDER and WATCH FOR NECK SHAPING. FOR SHOULDER, ON EACH SIDE, bind off 5 sts. 1x, 6 sts. 4x, (8 sts. 1x, 6 sts. 4x), *FOR NECK, after Row 318, bind off the center 32 sts., put the needles on the left into holding position and complete the right side first. ON NECK SIDE, bind off 4 sts. 2x. Bring the needles on the left into working position, knit 1 row in Pattern to the left side, turn the Row Counter back to 318 and complete the left half. Follow the instruction from * but don't forget to complete shoulder shaping.

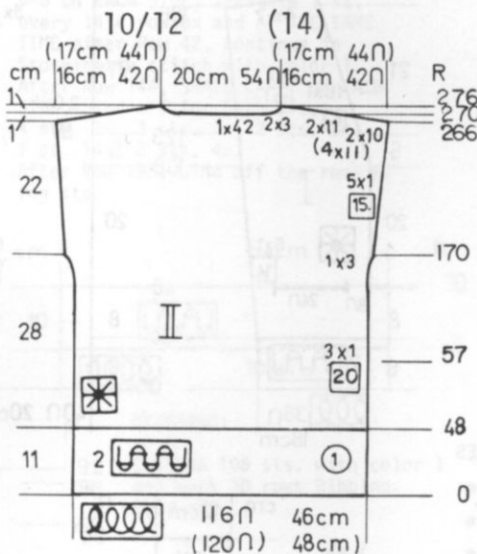

PULLOVER BACK II

Cast on 116 (120) sts. with color 1 and work 48 rows Ribbing. Continue in Pattern. ON EACH SIDE, increase 1 st. every 20th row 2x, changing to color 2 after Row 57. After Row 170, change to color 1 and ON EACH SIDE, cast on 3 sts. 1x. ON EACH SIDE, increase 1 st. every 15th row 5x. After Row 266, SHAPE SHOULDER and WATCH FOR NECK SHAPING. FOR SHOULDER, bind off ON EACH SIDE 10 sts. 2x, 11 st. 2x, (11 sts. 4x), AT THE SAME TIME, for NECK, after Row 270, bind off the center 42 sts. put the needles on the left into holding position and complete the right side first. *ON NECK SIDE, bind off 3 sts. 2x. Bring the needles on the left into working position, knit 1 row in Pattern to the left side, turn the Row Counter back to 270 and complete the left half. Follow the instructions from * but don't forget to complete the shoulder shaping.

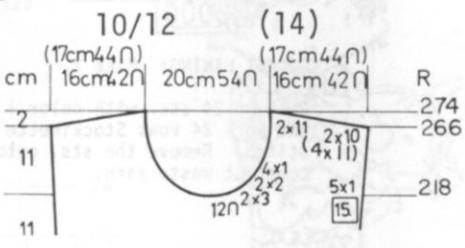

PULLOVER FRONT: I

Work the front the same as the back to Row 218. Put half the sts. on the left into holding position and complete the right side first. *ON NECK SIDE, bind off 12 sts. 1x, 3 sts. 2x, 2 sts. 2x, 1 st. 4x and at the same time, continue the increases at arm side. After Row 266, SHAPE SHOULDER same as the back. Bring the needles on the left into working position, knit 1 row in Pattern to the left side, turn the Row Counter back to 218 and complete the left half. Follow the instructions from *.

POCKET BAND

Hang the open sts. of Pocket held on stitch holder back onto the machine with purl side facing you. Work the Picot Hem and then bind off.

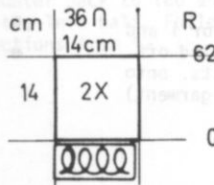

POCKET LINING: Make 2.

Cast on 36 sts. with color 2 and work 62 rows Stockinette stitch. Remove onto waste yarn.

Sew 1 shoulder of front and back together then pick up the sts. around neck evenly and work Picot Hem same as you did for Dress.

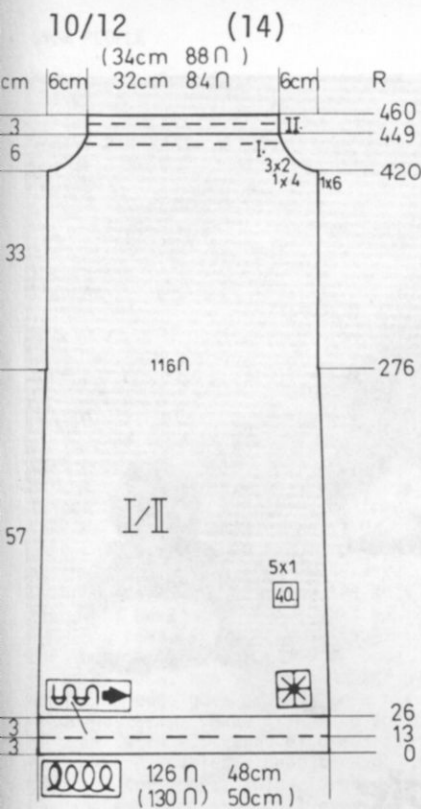

DRESS: Front & Back the same.

Cast on 126 (130) sts. with color 1 and work Stockinette stitch. After Row 13, make Picot and after Row 26, hang hem. Continue in Pattern. ON EACH SIDE, decrease 1 st. every 40th row 5x. After Row 276, mark each side for waistline. After Row 420, SHAPE ARMHOLE: ON EACH SIDE, bind off 4 sts. 1x, 2 sts. 3x. After Row 449, make Picot across then hang hem after Row 460 and bind off. Work second section the same.

STRAPS FOR DRESS:

Cast on 14 sts. 7 sts. on main machine, 7 sts. on ribber and work Circular for desired length. Bind off.

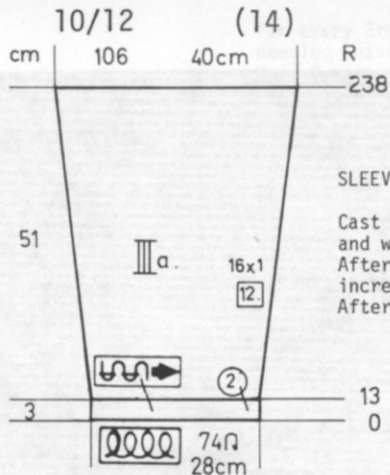

SLEEVES:

Cast on 74 sts. with color 2 and work Stockinette stitch. After Row 13, ON EACH SIDE, increase 1 st. every 12th row 16x. After Row 238, bind off.

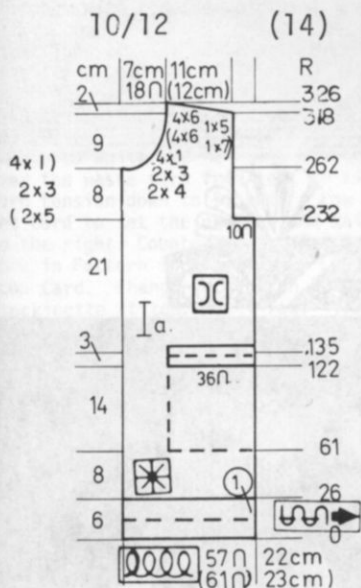

JACKET FRONT: I (MAKE POCKET LININGS FIRST).

Cast on 57 (61) sts. with color 1 and work the Picot hem same as you did for dress. Continue in Pattern with color 2. Knit to Row 122. Remove 36 sts. on the right (left for 2nd section) onto a stitch holder. Hang Pocket Lining. Knit to Row 232. SHAPE ARMHOLE: Bind off 10 sts. After Row 261, SHAPE NECK: Bind off 4 sts. 2x, 3 sts. 2x, 1 st. 4x. (5 sts. 2x, 3 sts. 2x, 1 st. 4x). After Row 318, SHAPE SHOULDER: Bind off 5 sts. 1x, 6 sts. 4x. (7 sts. 1x, 6 sts. 4x). Work the second section with reverse shaping.

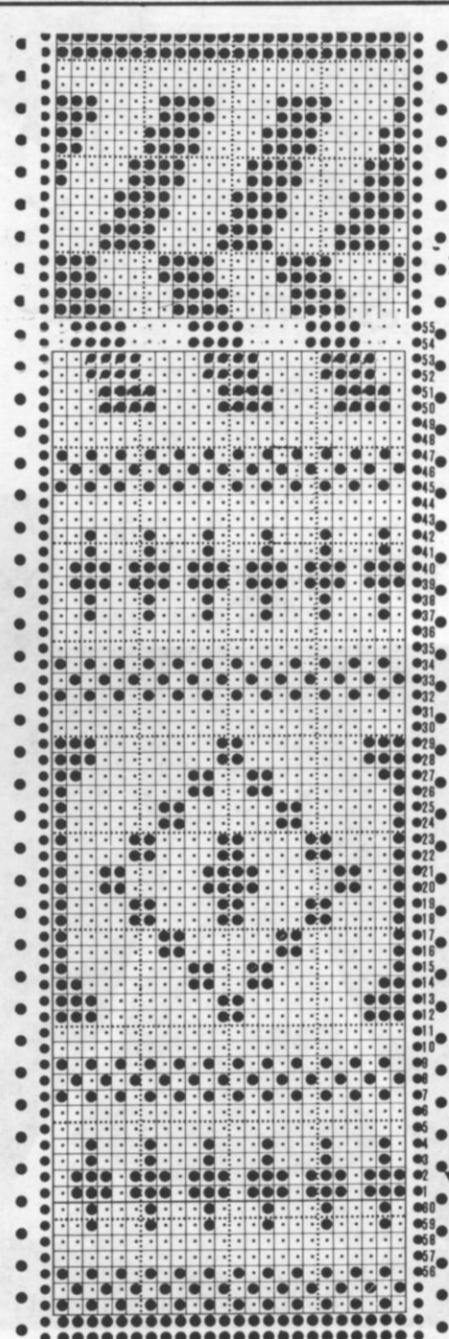

PUNCH CARD FOR DK 787
on Page 41.



String Apple

Snow People

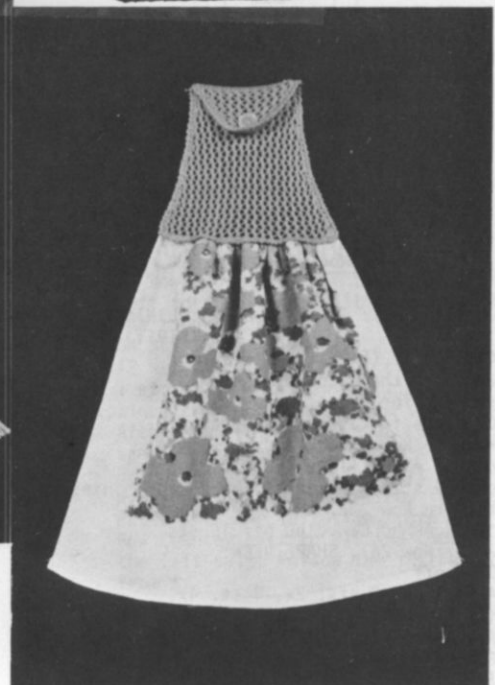

*Button on
Hand Towels*

SNOW PEOPLE

YARN: Euro Sport
 GRAMS:
 color 1 White = 100
 color 2 Red = 50
 color 3 Green = small amount
 TENSION: 5 to 7
 GAUGE: 11 sts. 28 rows = 5 cm (2")
 You will also need 6 Styrofoam Balls
 1 each - 3" & 4" (Large)
 1 each - 2 1/2" & 3" (Medium)
 1 each - 2" & 2 1/2" (Small)

A simulated Rib stitch. Punch your own Card and push in BOTH TUCK BUTTONS for Pattern.

FINISHING: Rub the larger balls on a piece of sandpaper until they are flat enough to stand up (base). Mark the exact center of the top of larger balls then lightly sand them. Sand each of the smaller balls on oneside only then glue them to the top of the larger balls. Allow to dry. Cover the double balls with the knitting, and weave the seam. Pull up over the head (just over the top) it does not completely cover. If lower edge is loose, run yarn around and pull up so the edge goes underneath a bit. Weave hat seam. Make fringe on bottom of scarf with 4 strands of green cut 4" long and doubled. Loop through ends and cut short. Glue large eyes to Papa and Mama and small eyes to Baby. Work mouth with red - 2 straight stitches with red (see picture).

Directions are for LARGE with Medium in () and Small in [].

With contrast waste yarn, cast on 68 (50) [40] sts. Knit 4 to 6 rows, change to White and 'e' cast on right over the waste yarn from left to right. Turn tension down to 5, knit 1 row Set Card to set the needles and knit to the right. Counter at 2. Tension 6. Work in Pattern to Row 84 (62) [42]. Stop Card. Change to Tension 5 and Stockinette stitch. Knit 1 row. Trans-

Snow People

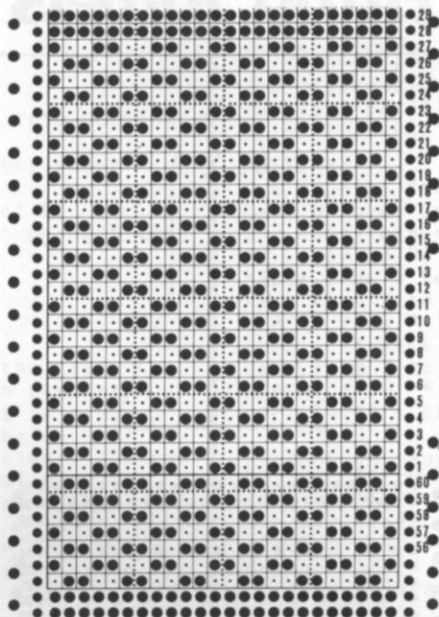

fer every 3rd st. to neighboring needle. Leave empty needles out of work. Knit 3 more rows, then 1 row Tension 10. Latch tool bind off.

HATS: Use open cast on same as for body -head. Change to Red and 'e' cast on. Counter at 0. Set Card after Row 1 - left to right. With Tension 9, Rib 8 rows for all sizes. Change to Tension 10 and work Stockinette stitch. Knit 10 (8) [6] rows. Remove the sts. onto waste yarn. Hang the sts. back onto machine 2 sts. together across but 1 st. at each end. Knit 6 (6) [4] rows. Hang every 3rd sts. onto neighboring needle. Leave empty needle out of work. Tension 6, knit 6 (4) [2] rows. Pull yarn through and tie but leave end for weaving seam.

GREEN SCARVES

1 = needle in work.
 0 = needle out of work.

10101

With green cast on over the 3 needles as shown. Tension 7. Knit 2 rows. *Put 2 needles on left into holding position, knit 2 rows. (Do not wrap). Bring 1 needle back into work, Knit 2 rows. All needles in work, knit 1 row to the left side. Put 2 needles on right into holding position, knit 2 rows. Bring 1 needle back into work, knit 2 rows. All needles in work, knit 1 row to the right side. REPEAT FROM * for Pattern. Make Scarf 11" (9") [7"] long.

String Apple

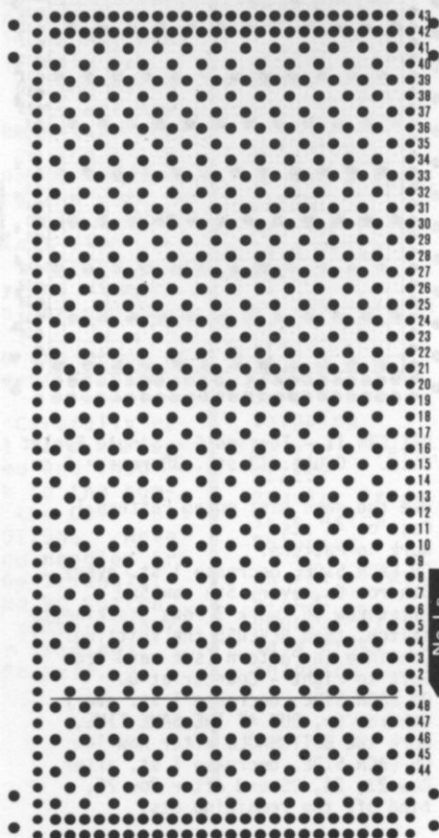

LEAVES: Small amount of green. Make 2. Cast on 13 sts. Knit 8 rows. *Hang the stitch each side of center onto center needle and move the sts. in to fill empty needles. Knit 2 rows and REPEAT from * till 3 remain. Hang each side st. onto center needle and bind off.

ALTERNATE LEAVES:

With green, cast on 11 sts. Knit 2 rows. *Put the center needle into holding position every other row and back the next row, BUT AT THE SAME TIME, after Row 10, decrease 1 st. each side every 2nd row until 3 remain. Hang each side st. on center needle and bind off. Pick up 11 sts. from cast on row and work the other leaf, knit 2 rows then repeat from *.

FINISHING:

Sew back seam then pull cover over ball of cord. Run round elastic through open sts. and remove waste yarn (this end should be on bottom of ball of cord where end pulls from). Pull up the top with end of yarn to close top then sew leaves in place. Work single crochet around bone ring so it is covered. Make a cord over 2 needles with green making it as long as you want. Loop cord through sissors and sew ends to top of apple in the center then sew on bone ring.

STRING APPLE

YARN: Euro Sport - Red
 GRAMS: 50 (will make several).
 TENSION: 10
 GAUGE: 9 sts. 24 rows = 5 cm (2")

You will also need a ball of cord that pulls from the center and a pair of inexpensive sissors and 1/2 or 3/4" bone ring.
 840, 830, and 820 machine owners use Card No. 1 of your original set. Push in BOTH TUCK BUTTONS for Pattern.

With contrast waste yarn, cast on 44 sts. After knitting 8 rows, change to Euro Sport and put Counter at 0. Tension 6. Knit 5 rows Stockinette stitch Set Punch Card from let to right. (R-6). Work in Pattern.
 Tension 8 - 2 rows.
 Tension 9 - 2 rows.
 Tension 10 - knit to Row 36.
 Tension 9 - 2 rows.
 Tension 8 - 2 rows.
 Tension 6 - 2 rows.
 Transfer every other stitch to adjacent needle and leave empty needles out of work. Continue in Stockinette stitch with Tension 5. Knit 4 rows and remove on end of yarn.

BUTTON ON HAND TOWELS

YARN: Amore
GRAMS: 50 (will make 2 or more depending on Pattern).
TENSION: Each towel is a different tension - so check pattern.
GAUGE: Check each pattern.
 You will also need - large size terry cloth hand towel at least 24" long as you must cut it in half. Each towel will make two.

FINISHING: Cut towel in half. Zig-gag the cut ends on your sewing machine or if you have a BABY LOCK, sew ends cutting off as little as possible. Gather ends close to stitching either with 2 rows of running stitch by hand or on your sewing machine. Work 1 row single crochet, then 1 row reverse single crochet all around knitted top. (No. 5 crochet hook is good). Pull up gathers to fit knitted piece and pin in place to cover gathers on the RIGHT side. With Amore, work blanket stitch on the WRONG SIDE, going through towel edge and knitting but be careful not to go through to the right side of knitting. Fold tab over to the right side and mark for button then sew button in place.

Button on Hand Towels

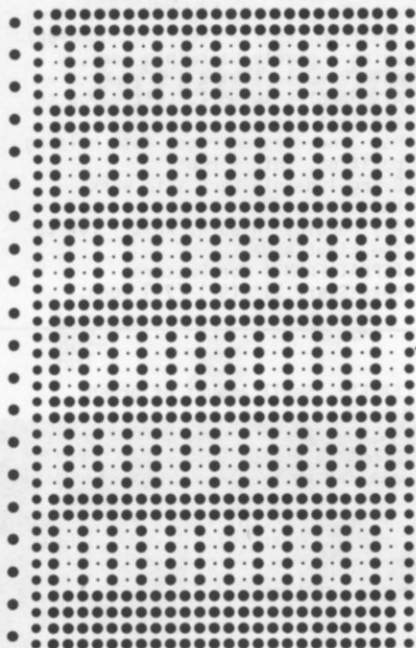
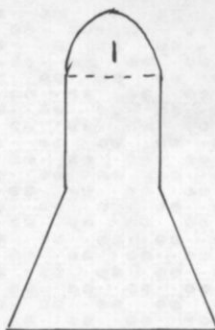

PATTERN I - TUCK - Tension 7
 Gauge: 11 sts. 40 rows.

With contrast waste yarn, cast on 38 sts. Knit 8 rows, change to Amore and 'e' cast on right over the waste yarn from left to right. Turn tension down 1 number, knit 1 row to the left. Set Card for setting the needles and knit to the right side. Activate the Card. Turn Tension to 7 and continue in Pattern.
ON EACH SIDE, decrease 1 st. every 14th row 9x.
 After Row 130, knit 2 rows Stockinette stitch then REVERSE knitting. Counter at 0. Continue in Pattern.
ON EACH SIDE, decrease 1 st. every 11th row 5x BUT AT THE SAME TIME, work BUTTONHOLE as given after Row 40.
ON EACH SIDE, decrease 1 st. after Row 50 and 51. After Row 52, bind off the remaining sts.

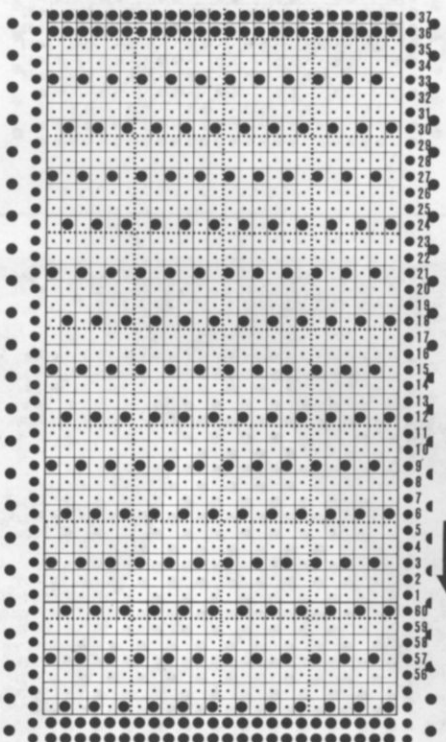

PATTERN II - Tension 5 - Single Eyelet Lace. Gauge: 13 sts. 30 rows = 5 cm.

Use the same Cast on as Pattern I. Cast on 44 sts. Work in Pattern.
ON EACH SIDE, decrease 1 st. every 6th row 6x, every 5th row 5x.
 After Row 66, work 3 rows Stockinette stitch, then REVERSE the knitting. Continue in Pattern (set card from left to right - Counter at 0).
ON EACH SIDE, decrease 1 st. every 4th row 5x, BUT AT THE SAME TIME, work the BUTTONHOLE after Row 14.
ON EACH SIDE, decrease 1 st. after Row 23, 24, 25 and after Row 26, bind off the remaining sts.

NOTE: There are 3 different Pattern Stitches using different Cards. The first Pattern can be used on the knit or purl side.

EASY VERTICAL BUTTONHOLE
 Work this buttonhole on the designated row for each Pattern.
 Cut a strand of Amore 6 inches long. At the designated row, remove the center stitch onto this strand of yarn and put the empty needle out of work. Knit 4 rows. Thread same yarn onto tapestry needle and go UNDER the 4 strands made by empty needle then pull down and tie one time - just to hold the strands. Knit 4 more rows. With transfer tool, go UNDER the 4 strands just made by empty needle and hang them onto the empty needle. Bring this needle into holding position to make sure it knits the strands off on the next row. Continue always in Pattern.
 To finish the buttonhole, you need only to thread the ends of yarn on lower part into tapestry needle and bring the yarn through to the right side then go down through very edge of knitting to the wrong side and secure ends. This makes buttonhole look the same on each end.

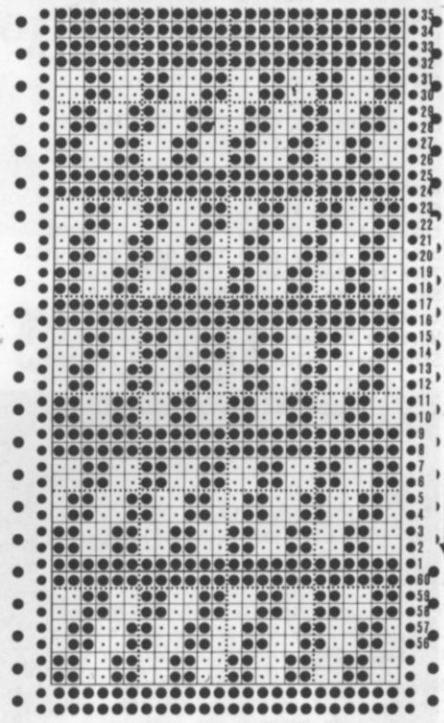

PATTERN III - Tension 6 - Push in the RIGHT TUCK BUTTON and the LEFT PART BUTTON. Gauge: 14 sts. 30 rows = 5 cm (2")

Use the same Cast on as Pattern I. Cast on 48 sts. and work in Pattern.
ON EACH SIDE, decrease 1 st. every 8th row 11x.
 After Row 98, knit 2 rows Stockinette stitch and REVERSE THE KNITTING. Continue in Pattern - Counter at 0.
ON EACH SIDE, decrease 1 st. every 4th row 6x, BUT AT THE SAME TIME, work BUTTONHOLE after Row 28.
ON EACH SIDE, decrease 1 st. after Rows 34, 36, and bind off 2 sts. after Row 38.
 After Row 40, bind off the remaining sts.



KNITTING NEWS

PRACTICAL KNITTING HINTS

THE PICOT HEM

Bring the required number of needles into working position. Hang the cast on comb.
 Bring the 2nd from the left, then every other needle into 'D' or 'E' position.
 Push in BOTH PART BUTTONS. Counter at 0.
 Turn Tension down 1 number lower than garment tension (for example tension 4).
 Knit 1 row to the LEFT.
 Drop cast on comb, put on weights.
 Release Part Buttons.
 Knit 1 row to the right.
 Knit to Row 11 - Carriage is now on the LEFT.
 Turn Tension up 2 numbers larger than garment tension (tension 6). Knit 1 row left to right.
 Turn Tension to original tension (Tension 4).
 Bring every other needle to 'D' position - You can use every other needle Lace Card - Set needles from left to right, transfer sts. from right to left.
 Knit 12 rows. Carriage is now on the RIGHT side.
 Beginning with first needle on the left, bring every other needle to 'D' position. Lift the cast on comb UP and hang sts. to make hem.
 Turn to Garment Tension (Tension 5) and continue with garment. Be sure to put the Row Counter at the correct row AFTER making the hem.

SHAPE NECKLINE with stitches in holding position on the LEFT (Fair Isle Technique).

Write down the Row number on the Card. This is very important.... Carriage is on the right side.
 With a Ravel Cord, knit each stitch on the left half BY HAND, pulling EACH STITCH all the way back to the out of work position. You will only be knitting it partly... When you have pulled each stitch back against the needle bed - they are now OUT OF WORK. Take a piece of cellophane tape and lightly place it UNDER the Gate Pegs on the knitting - across all the stitches held on the left.
 The prevents the Carriage from marking the yarn on the left as you knit the right half. This is not so important when you are using the knit side as the right side as the Carriage marks the purl side, but it is a good thing to know anyway and nice to have the purl side unmarked. You can now continue to knit and shape the right side.
 When the right side is completed, you are ready to knit the left half. In order to prevent problems, so it this way....
 Move the Carriage to the LEFT SIDE. Carefully remove the tape, then pull on the Ravel Cord, bringing the stitches back onto the needles and into working position. Turn the Card back to the number you wrote down. Set the Card on the DOT. Set the Knob to KC. Push in BOTH PART BUTTONS. Move the Carriage across WITHOUT yarn. The needles are now set properly. Put the Knob on the Triangle.
 Release the Part Buttons. Push in the MC Button.
 Turn the Row Counter back to correct number (where you starter the neck or neck/shoulder shaping).
 Continue to knit and complete the left half.

WOMAN'S VEST - DK 731, Volume 15, No. 1

The instructions for knitting the Pattern Stitch for Vest DK 731 was omitted in the Magazine. We print it here.

PATTERN:

Set machine for FISHERMAN'S RIB.
 Cast on over every other needle on the Knitter and every other needle on the Ribber.
 PH Lever on H.
 *Rack from 5 to 7, push Carriage across.
 Rack from 7 to 5, push Carriage across.
 REPEAT from * 19x more (20x in all).
 Then - ** Rack from 5 to 7, Push Carriage across.
 Rack from 7 to 5, push Carriage across.
 REPEAT from ** 19x more (20x in all).
 PATTERN IS A REPEAT FROM * to **.

DISCOUNTED YARN KITS FOR THIS ISSUE

The Yarn Kits for this issue of KNITTING MAGAZINE are available at special discounts to our subscribers and the prices are only good until the next issue of the magazine. Be sure to give alternate colors.

KK 765 - Yarn: Amore			
SIZES:	8	(10)	[12]
Regular Price	\$16.40	\$16.40	\$18.45
Sale Price	13.12	13.12	14.76
Shipping	1.85	1.85	1.85
KK 766 - Yarn: Crocus			
SIZES:	4	(6)	[8]
Regular Price	\$25.20	\$25.20	\$28.35
Sale Price	20.16	20.16	22.68
Shipping	1.85	1.85	1.85
KK 767 - Yarn: Vienna			
SIZES:	1 yr.	(2 yr.	[3 yr]
Regular Price	\$11.75	\$11.75	\$14.10
Sale Price	9.40	9.40	11.28
Shipping	1.85	1.85	1.85
DK 768 - Yarn: Micaela			
SIZES:	Small	Medium	
Regular Price	\$22.90	\$25.19	
Sale Price	18.32	20.15	
Shipping	1.85	1.85	
KK 769 - Yarn: Vienna (sewing thread or Monofil not included in Kit)			
SIZES:	4	(6)	[8]
Regular Price	\$ 9.40	\$ 9.40	\$11.75
Sale Price	7.52	7.52	9.40
Shipping	1.85	1.85	1.85
KK 770 - Yarn: Crocus			
SIZES:	10	(12)	[14]
Regular Price	\$25.20	\$25.20	\$28.35
Sale Price	20.16	20.16	22.68
Shipping	1.85	1.85	1.85
KK 771 - Yarn: Amore			
SIZES:	4	(6)	[8]
Regular Price	\$14.35	\$14.35	\$16.40
Sale Price	11.48	11.48	13.12
Shipping	1.85	1.85	1.85

DK 772 - Yarn: Fortissima			
SIZES:	12	(14)	[16]
Regular Price	\$28.38	\$30.96	\$33.54
Sale Price	22.70	24.77	26.83
Shipping	1.85	1.85	1.85
HP 773 - Yarn: Fortissima			
SIZES:	38/40	(42)	
Regular Price	\$25.80	\$30.96	
Sale Price	20.64	24.77	
Shipping	1.85	1.85	
HP 774 - Yarn: Vienna			
SIZES:	38/40	(42)	[44]
Regular Price	\$35.25	\$35.25	\$39.95
Sale Price	28.20	28.20	31.96
Shipping	1.85	1.85	1.85
DK 775 - Yarn: Amore & Micaela			
SIZES:	8/10	(12)	[14]
Regular Price	\$36.05	\$36.05	\$40.39
Sale Price	28.84	28.84	32.31
Shipping	1.85	1.85	1.85
HP 776 - Yarn: Vienna			
SIZES:	34/36	(38)	[40]
Regular Price	\$21.15	\$23.50	\$25.85
Sale Price	16.92	18.80	20.68
Shipping	1.85	1.85	1.85
DK 777 - Yarn: - No Kit Available			
KK 778 - Yarn: Crocus			
SIZES:	6	(8)	[10]
Regular Price	\$28.35	\$31.50	\$34.65
Sale Price	22.68	25.20	27.72
Shipping	1.85	1.85	1.85
KK 779 - Yarn: Crocus			
SIZES:	14	(16)	
Regular Price	\$34.65	\$37.80	
Sale Price	27.72	30.24	
Shipping	1.85	1.85	
DK 780 - Yarn: Vienna & sewina thread			
SIZES:	8/10	(12)	[14]
Regular Price	\$39.20	\$41.55	\$41.55
Sale Price	31.36	33.24	33.24
Shipping	1.85	1.85	1.85

DK 787 - Yarn: Euro Sport			
SIZES:	8/10	(12/14)	
Regular Price	\$59.50	\$63.00	
Sale Price	47.60	50.40	
Shipping	2.60	2.60	
HP 788 - Yarn: Euro Sport			
SIZES:	38	(40)	
Regular Price	\$22.75	\$26.25	
Sale Price	18.20	21.00	
Shipping	1.85	1.85	
DK 789 - Yarn: Euro Sport			
SIZES:	8	(10/12)	
Regular Price	\$17.50	\$19.25	
Sale Price	14.00	15.40	
Shipping	1.85	1.85	
DK 790 - Yarn: Vienna			
SIZES:	10.12	(14)	
Regular Price	\$47.00	\$49.35	
Sale Price	37.60	39.48	
Shipping	1.85	2.60	
DK 781 - Yarn: Amore (Material plus odd amounts of different colors not included)			
SIZE:	One Size only. Small/Medium		
Regular Price	\$24.60		
Sale Price	19.68		
Shipping	1.85		
DK 782 - Yarn: Euro Sport			
SIZES:	8/10	(12/14)	
Regular Price	\$22.75	\$28.00	
Sale Price	18.20	22.40	
Shipping	1.85	1.85	
DK 783 - Yarn: Amore & Euro Sport			
SIZES:	10/12	(14)	[16]
Regular Price	\$45.60	\$45.60	\$45.60
Sale Price	36.48	36.48	36.48
Shipping	2.60	2.60	2.60
DK 784 - Yarn: Vienna			
SIZES:	10	(12)	[14]
Regular Price	\$16.45	\$23.50	\$23.50
Sale Price	13.16	18.80	18.80
Shipping	1.85	1.85	1.85
DK 786 - Yarn: Crocus			
SIZES:	8/10	(12/14)	
Regular Price	\$53.55	\$59.85	
Sale Price	42.84	47.88	
Shipping	1.85	1.85	

converta tape

CONVERTA TAPES ARE HERE AGAIN!!! That marvelous Accessory the CONVERTA TAPE has been unavailable for two years... and we have them again, made in Germany to the original design... Using the Tape makes the charting of garments to size ten times easier... Just make a sample swatch, set the Tape to its Stitch (or Row) Gauge, measure the person and you get an instant reading of stitches or rows needed... Use a Converta Tape also to immediately convert KNITTING MAGAZINE and other patterns for use with thinner or thicker yarns.

NO knitter should be without a
KNITTING CONVERTA TAPE...

Calif. residents add Sales Tax.
Shipping Costs \$1.25

\$15.95

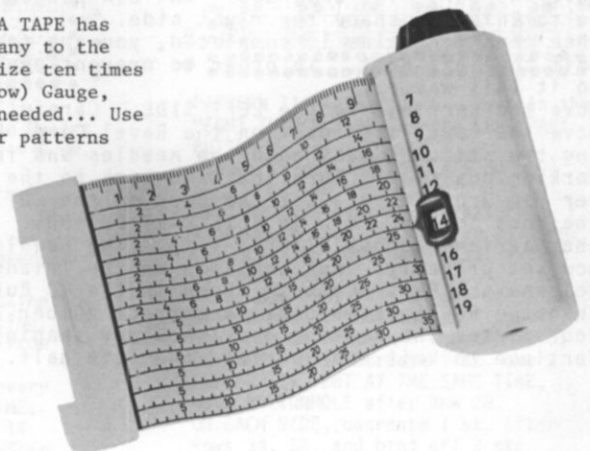

Order direct from KNITTING - 1128 Crenshaw Blvd., Los Angeles, California 90019



dk 780



dk 790



OK 786



hp 176

KK 765



dk 768

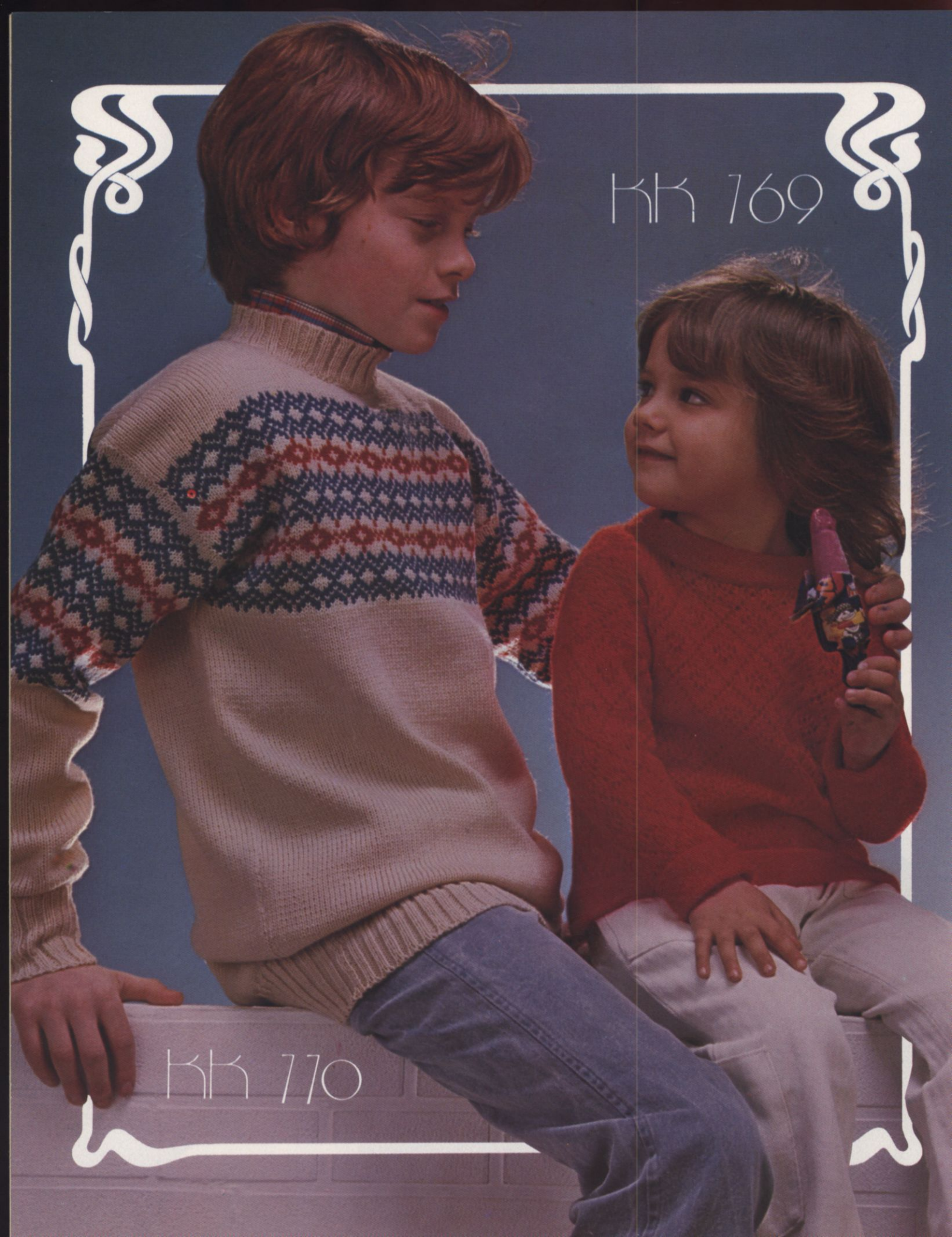

KK 769

KK 770

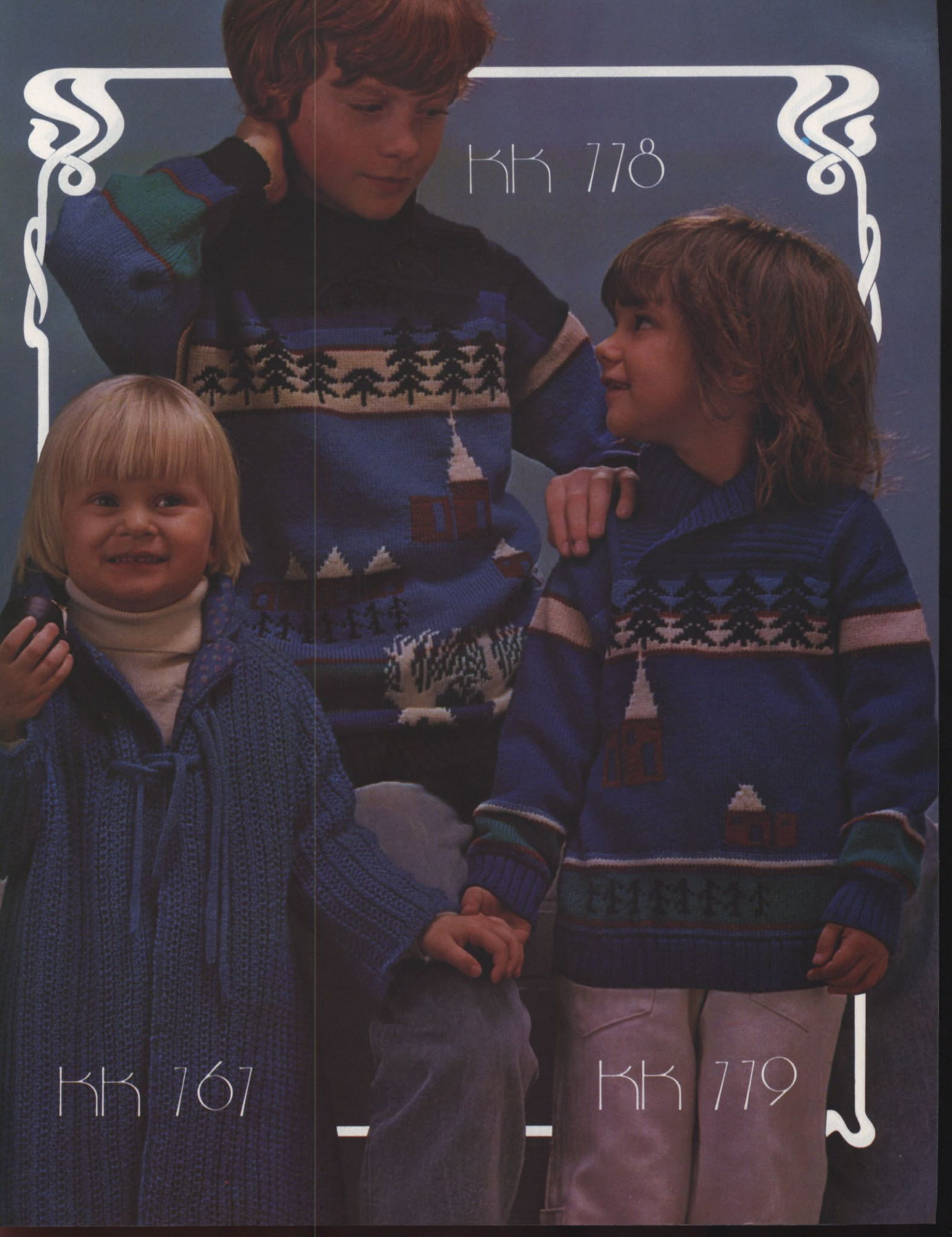

KK 778

KK 767

KK 779

dk 787

