

knitking

magazine

SEPT./OCT. '76



dk 372

dk 371

dk 373





hp 369



OK 361

OK 360

dk 300





dk 376

dk 375

np 362

dk 374



dk 385



hp 386



dk 368



dk 370





AK 307

knitking

magazine

editorial

September/October 1976

It is said that fashion is entering an age of elegance... If such is the case, then we are emphatically in favor of it... and we make our initial contribution to elegance with the outstanding garments in this issue.

The period of faded denim and used clothing was fun while it lasted, but it was inevitable for the human animal to return to dressing up rather than dressing down and to want to look smart, tidy and trim as opposed to disheveled and shapeless... To look good is to feel good and when you own a knitting machine, you can look good at a much lower cost than less fortunate people who have not experienced the joy of creating and wearing their own creations.

We have a preference (and correspondence shows that the majority of our readers agree with us) for understated elegance rather than flamboyance... and, we point to the front cover garment of this issue to emphasize our choice... What woman would not feel good in such an elegant outfit?... One of its many advantages is that it can be worn by women of most sizes... You can make it for less than \$30.00 using new and beautiful KNITKING Micaela yarn in the color of your choice. It is so easy to make on practically any brand of knitting machine.

The Tabard and Dress combination (DK 360 - DK 361) is a fine example of style plus elegance... It can also be worn by and look good on the larger size woman (Bea Arthur, of the program 'Maude' has certainly helped make the tunic top popular). The entire outfit is made in handsome Crocus Crepe and you can duplicate it for less than \$40.00. You can also knit the tunic in different designs and colors to match other dresses and pants... You can make the Tunic for around \$10.00... and isn't DK 370 a simply gorgeous evening robe? What woman wouldn't feel elegant and glamorous wearing it?

The Jumpsuit DK 384 is in response to many requests for what has become a very popular fashion garment for both sexes. You can make it with new glamorous Micaela for around \$35.00... Spin the pages and you will find that every garment is stunning... We are not forgetting the men in this elegant issue and are featuring some outstanding pull-overs plus that handsome Fisherman Rib zip Cardigan HP 386. Children too love to dress up and look good, so we have some lovely knits for them... isn't that picture of the young lady modeling KK 378 simply charming?... You can just see how she enjoyed dressing up to have her picture taken....













To encourage you and your family to look your best in time for the holiday season, we are offering big discounts on all the yarns for the garments in this issue. They are listed in KNITKING NEWS and you will need the new KNITKING YARN CATALOGUE to make your choice of colors... Don't forget to make up some of the Christmas gift items, then look forward to more lovely new fashions in our November/December issue.



TABLE OF CONTENTS	PAGE NO.
DK 360 Woman's Dress	14
DK 361 Woman's Tabard	15
HP 362 Man's Pullover	17
KK 363 Child's Tights	18
KK 364 Child's Pullover	19
KK 365 Boy's Pullover.	20
DK 366 Woman's Pullover	21
DK 368 Woman's Bedjacket	22
HP 369 Man's Pullover.	24
DK 370 Woman's Robe	25
DK 371 Woman's Bolero	27
DK 372 Woman's Pullover	28
DK 373 Woman's Skirt	29
DK 374 Woman's Skirt	30
DK 375 Woman's Shawl	30
DK 376 Woman's Pullover	31
KK 378 Child's Coat	32
HP 377 Man's Pullover	33
KK 379 Child's Knee Socks	35
DK 380 Woman's Dress	36
DK 390 Woman's Skirt	37
KK 381 Girl's Jacket & Head Scarf	38
DK 382 Woman's Long Skirt	39
DK 383 Woman's Blouse.	39
DK 384 Woman's Jumpsuit	41
DK 385 Woman's Dress	43
HP 386 Man's Jacket	46
DK 387 Woman's Suit	47
DK 391 Woman's Pullover	50
KG 1989 Santa Doorknob Cover	51
KG 1990 Food Jar Boot or Sock	51
KG 1991 Angel	53
KG 1992 Bells	53
KG 1993 Christmas Tree	53
KG 1994 Santa	53
KG 1995 Pony Curls	52

Publisher: KNITKING CORPORATION, 1128 Crenshaw Blvd., Los Angeles, Calif. 90019. Telephone: (213) 938-2079. Published bi-monthly. Subscriptions: USA — \$10.00 annually, single copies \$3.00; Canada — \$12.00; other parts of the world — \$15.00. The entire contents of KNITKING MAGAZINE are copyright and must not be reproduced in any shape or form without the express permission, in writing of the publisher. © COPYRIGHT 1976 by KNITKING CORPORATION.

Pattern Symbols

Knitting — Chart Symbols

- () Size Symbols
(2nd Size)
- < > 3rd Size
- B** Beginners Pattern
- T** Tension
- G** Gauge
- 1** Color Number
-  Cast on
- n** Stitch
- R** Row
- H** Hem
-  Bind off
-  Stockinette stitch — worn on the Knit side.
-  Stockinette stitch — worn on the Purl side.
-  Knit 1, Purl 1 Ribbing
-  Ribbing Pattern — worn on the Knit side.
-  Ribbing Pattern — worn on the Purl side.
-  Closed Dart
-  Open Dart
-  Put on a stitch holder
-  Reverse 1 section
-  On every other needle
- 4** Number of Rows between Shapings. Make increase (or decrease) FIRST, then knit 4 rows. For example: 3 x 1  means decrease (or increase) 1 st., knit 4 rows; decrease 1 st., knit 4 rows; decrease 1 st., knit 4 rows; decrease 1 st., knit 4 rows. All decreasing (or increasing) without row numbers as shown must be shaped on every 2nd row.

-  Increase
-  Increase 2 sts. With a transfer tool, move the sts. over the left (or right) leaving 2 empty needles at the point of increase. At the increase point, move 1 st. to the left, (or right) so that there is an empty needle on each side of a stitch. On each side of the center stitch, pick up a stitch from the row below and hang it onto the empty needle.

-  3 stitches on 1 needle. The 1st and 3rd stitch in a group of 3 has been hung on the 2nd or center needle.

-  Short Row increase or decrease; for instance on a flared skirt knitted sideways.

-  Pattern Stitch

-  Pattern Stitch — worn on the Knit side.

-  Pattern Stitch — worn on the Purl side.





-  Norwegian Design using the Pattern Reader. Only 1 row must be registered on the Pattern Reader, so when knitting two or more colors in 1 row, knit the first color with the LEVER of Pattern Reader UP (working), then push the LEVER DOWN (non-working) for the additional colors.

REPEAT the above for each complete row.

















-  Repeat

- I = Front
II = Back
III = Sleeve
IV = Skirt Front
V = Skirt Back
VI = Collar
VII = Pocket
VIII = Band
IX = Belt
X = Cuff
XI = Pants Front
XII = Pants Back

Finishing — Chart Symbols

-  Match numbers on section for assembling.
-  Ease
-  Fold Line
-  Turn to the wrong side and hem.

Stitch Symbols

-  Knit Stitch
-  Purl Stitch
-  Needles in holding position
-  Needles back into working position.
-  Empty needle (leave in working position)
-  Needle not used (in the out of work position).
-  Two stitches on 1 needle, either transferred from the right side or the left side, then put into holding position.
-  Needle holding 2 stitches. Stitch has been transferred from the RIGHT.
-  Needle holding 2 stitches. Stitch has been transferred from the LEFT.
-  Center of garment section
-  Pattern Reader
-  JAC 40
-  Adjustable Needle Selector
-  Pattern Wheel
-  Weaver
-  Needle Shifter



KnitKing News

NEW CHERI CONE YARN

We introduced a new fine cone yarn a few months ago and called it 'CHERI'... Its knitting and wearing qualities were so good we decided to make up another cone yarn using the identical material and colors, but in a heavier weight.

This means that the original fine weight CHERI has a name change. It is now called 'PETITE CHERI'. The new heavier weight yarn is called 'CHERI'.

There are samples of all yarns in the new KNITTING YARN CATALOGUE which also includes a chart listing tensions and row gauges for all KNITTING YARNS.

CANADIAN SUBSCRIBERS

Import duties, shipping costs, customs problems and lengthy delivery periods have made it increasingly difficult to ship KNITTING MAGAZINE in bulk to CANADA for distribution there. So, we ask that Canadian readers send new subscriptions and renewals direct to LOS ANGELES in future. The magazines will then be sent direct to subscribers as soon as they come off the press. The Canadian subscription price is \$12.00 per year.

PRACTICAL KNITTING HINTS

Decreasing a Number of Stitches Across a Section of Garment.

In this issue of KNITTING MAGAZINE, there are a number of garments where we are using an OPEN CAST ON for some sections. The reason is... it is easier to DECREASE stitches across the lower edge of a Sleeve for instance, than it is to work the Ribbing or band first, then increase a number of stitches across the row before knitting the main section of a sleeve.

For example DK 387: You need to decrease 16 stitches evenly across the sleeve after the main section is completed and you do this as you hang the open stitches back onto the machine in preparation for knitting the Ribbed band. Here is an easy way to set up the needles and figure the spacings for the decreases.

Following the Cuff Chart, bring 56 (60) [64] needles into working position. 16 stitches must be decreased, so you can figure you will need 17 spaces. We will work on the first size only for our example. If you need one of the other sizes, just do the figuring in the same way using the different number of stitches for your size band.... but the decreases of 16 sts. remain the same for all sizes.

$$\begin{array}{r} \text{Divide 17 into 56} \\ \begin{array}{r} 17 \overline{) 56} \\ \underline{- 51} \\ 5 \end{array} \\ \text{12x} \quad \text{5x} \end{array}$$

$3 + 1 = 4$ (stitches)

This is a standard formula used in many of the books available on Charting and it really works. As you can see, 17 will go into 56 3x with 5 left over. What do you do with the leftover is the question?... Subtract the 5 from the 17 and you have 12, then add 1 to the 3 which equals 4... This means that you will use 3 sts. and 4 sts. Your answer now is 3 sts. 12x, and 4 sts. 5x. The decreases are made across the 56 needles (needles in working position) by bringing every 4th needle into holding position 5x and every 3rd needle in holding position 12x. It is a good idea to space them as evenly as possible - so bring every 4th needle into holding 2x on one side and 3x on the other side, then in the center, bring every 3rd needle into holding position. Count these holding needles - you should have 16 of them. You are now ready to hang the open stitches of the sleeve

section onto the 56 needles. Each time you reach a holding needle, hang 2 sts. on that holding needle. When all of the open sts. have been hung onto the 56 needles, remove the waste yarn (check to be sure you have not missed any stitches), knit 1 row Stockinette stitch from Left to Right, then transfer every other stitch to the Ribber and work the cuff.

BIG DISCOUNTS ON KITS for Garments in this issue

Send in your Kit orders immediately, because when the next magazine comes out, these Kits will no longer be at this 'Special Price'. You can still get the Kits, but at regular prices (or at Sale Prices any time a Sale is running.

DK 360 - Yarn: Crocus Crepe			
SIZES:	8/10	(12)	[14/16]
Regular Price	\$33.44	\$37.62	\$41.80
Sale Price	25.12	28.26	31.40
Shipping costs	1.65	1.65	1.65

DK 361 - Yarn: Crocus Crepe			
SIZES:	7/8	(10/12)	[14]
Regular Price	\$33.44	\$37.62	\$41.80
Sale Price	25.12	28.26	31.40

HP 362 - Yarn: Allegro			
SIZES:	36/38	(40)	[42]
Regular Price	\$14.31	\$17.49	\$20.67
Sale Price	10.71	13.09	15.47
Shipping costs	1.65	1.65	1.65

KK 363 - Yarn: Amore			
SIZES:	6	(8)	[10]
Regular Price	\$10.43	\$10.43	\$11.92
Sale Price	7.84	7.84	8.96
Shipping costs	1.00	1.00	1.00

KK 364 - Yarn: Amore			
SIZES:	6	(8)	[10]
Regular Price	\$ 8.94	\$10.43	\$10.43
Sale Price	6.72	7.84	7.84
Shipping costs	1.00	1.00	1.00

KK 365 - Yarn: Euro Sport			
SIZES:	7/8	(10/12)	[14]
Regular Price	\$10.32	\$14.19	\$15.48
Sale Price	7.76	10.67	11.64
Shipping costs	1.65	1.65	1.65

DK 366 - Yarn: Crocus Crepe			
SIZES:	8/10	(12/14)	[16/18]
Regular Price	\$25.08	\$27.17	\$29.26
Sale Price	18.84	20.41	21.98
Shipping costs	1.65	1.65	1.65

KK 367 - Yarn: Euro Sport			
SIZES:	One Size		
Regular Price	\$ 5.16		
Sale Price	3.88		
Shipping costs	1.00		

DK 368 - Yarn: Cheri			
SIZES:	8/10	(12/14)	[16/18]
Regular Price	\$18.96 for 1 cone	(all sizes)	
Sale Price	14.22		
Shipping costs	1.25		

HP 369 - Yarn: Binia			
SIZES:	36/38	(40)	[42]
Regular Price	\$12.51	\$16.68	\$18.07
Sale Price	9.36	12.48	13.52
Shipping costs	1.65	1.65	1.65

[14/16]

BACK: II

FRONT: I

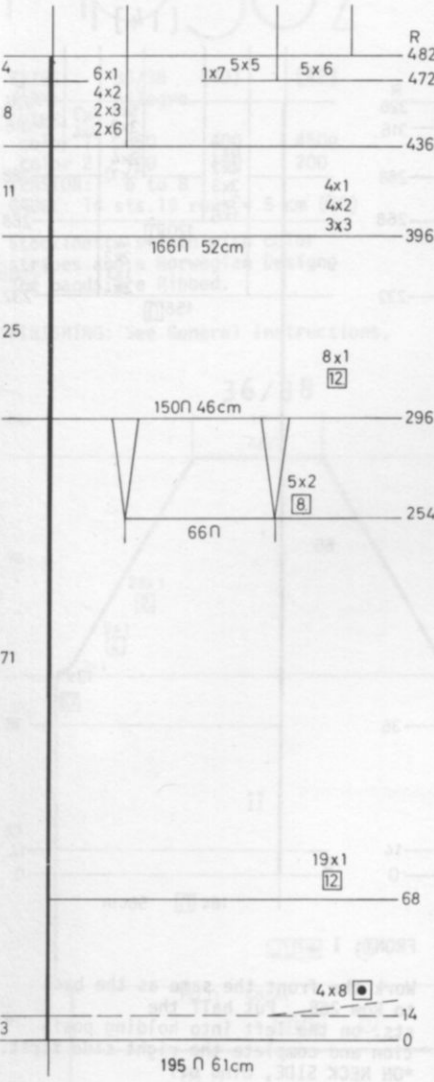

Cast on 185 (195) [195] sts. and work Stockinette stitch.
 Knit to Row 14, then work SHORT ROWS. ON OPPOSITE SIDE OF CAM BOX, put into holding position, 8 sts. 4x ON EACH SIDE.
 Bring all the needles back into working position before knitting the next 2 rows.
 After Row 50 (68) [68], SHAPE SIDE EDGE.
 ON EACH side, decrease 1 st. every 12th row 20x (19x) [19x] and after Row 254, SHAPE DARTS.
 Decrease 2 sts. FOR EACH DART ON EACH SIDE of the center 58 (58) [66] sts. and REPEAT the dart decreases directly above every 8th row 4x more.
 After Row 296, ON EACH SIDE, increase 1 st. every 16th row 5x. (every 16th row 5x). [every 12th row 8x].
 Knit to Row 380 (388) [396].
 SHAPE ARMHOLE: ON EACH SIDE bind off
 3 sts. 2x, 2 sts. 2x, 1 st. 4x. (3 sts. 3x, 2 sts. 2x, 1 st. 4x). [3 sts. 3x, 2 sts. 4x, 1 st. 4x].
 Knit to Row 456 (464) [470].
 Put half the sts. on the left into holding position and *SHAPE NECK and SHAPE SHOULDER after Row 458 (466) [472].
 FOR NECK, bind off
 5 sts. 6x. (5 sts. 6x). [7 sts. 1x, 5 sts. 5x].
 FOR SHOULDER, bind off
 7 sts. 3x, 5 sts. 1x. (7 sts. 3x, 8 sts. 1x). [6 sts. 5x].
 Move the Cam Box to the left side, turn the Row Counter back to 456 (464) [470] and complete the left half. Follow the instructions from *.

Work the front the same as the back to Row 380 (388) [396].
 SHAPE ARMHOLE same as the back then knit to Row 430 (436) [436].
 Put half the sts. on the left into holding position and *SHAPE NECK:
 Bind off
 6 sts. 1x, 5 sts. 1x, 3 sts. 2x, 2 sts. 4x, 1 st. 5x. (6 sts. 1x, 5 sts. 1x, 3 sts. 2x, 2 sts. 4x, 1 st. 5x).
 [6 sts. 2x, 3 sts. 2x, 2 sts. 4x, 1 st. 6x].
 SHAPE SHOULDER same as the back after Row 458 (466) [472].
 Move the Cam Box to the left side, turn the Row Counter back to 430 (436) [436] and complete the left half. Follow the instructions from *.

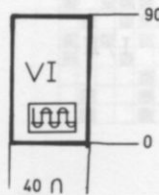

COLLAR: VI
 Cast on 40 sts. and work 90 rows K1, P1 Ribbing then bind off the crochet method for Ribbing.

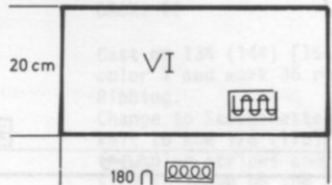

COLLAR: VI
 Cast on 180 sts. and work 90 rows K1, P1 Ribbing then bind off the crochet method for Ribbing

dk 361



WOMAN'S TABARD
 SIZES: 7/8 (10/12) [14]
 YARN: Crocus
 GRAMS:
 color 1 450 500 550
 color 2 350 400 450
 TENSION: 6 to 7
 GAUGE: 16 sts. 18 rows = 5 cm (2")

A Norwegian Design. Follow the Line Drawing or punch your own Card.

FINISHING: See General Instructions. Sew Bands on sides of front and back. Single crochet over Bone Rings then sew to sides as shown on the Chart. Make Cords for Ties. Cast on 6 sts. Set your machine for knitting a cord. Knit long enough to lace through rings and tie in Bow (See Picture).

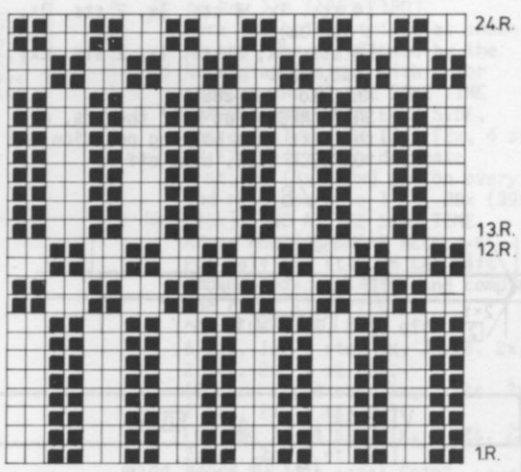

■ color 2
 □ color 1

(Continued on next page)



dk 361

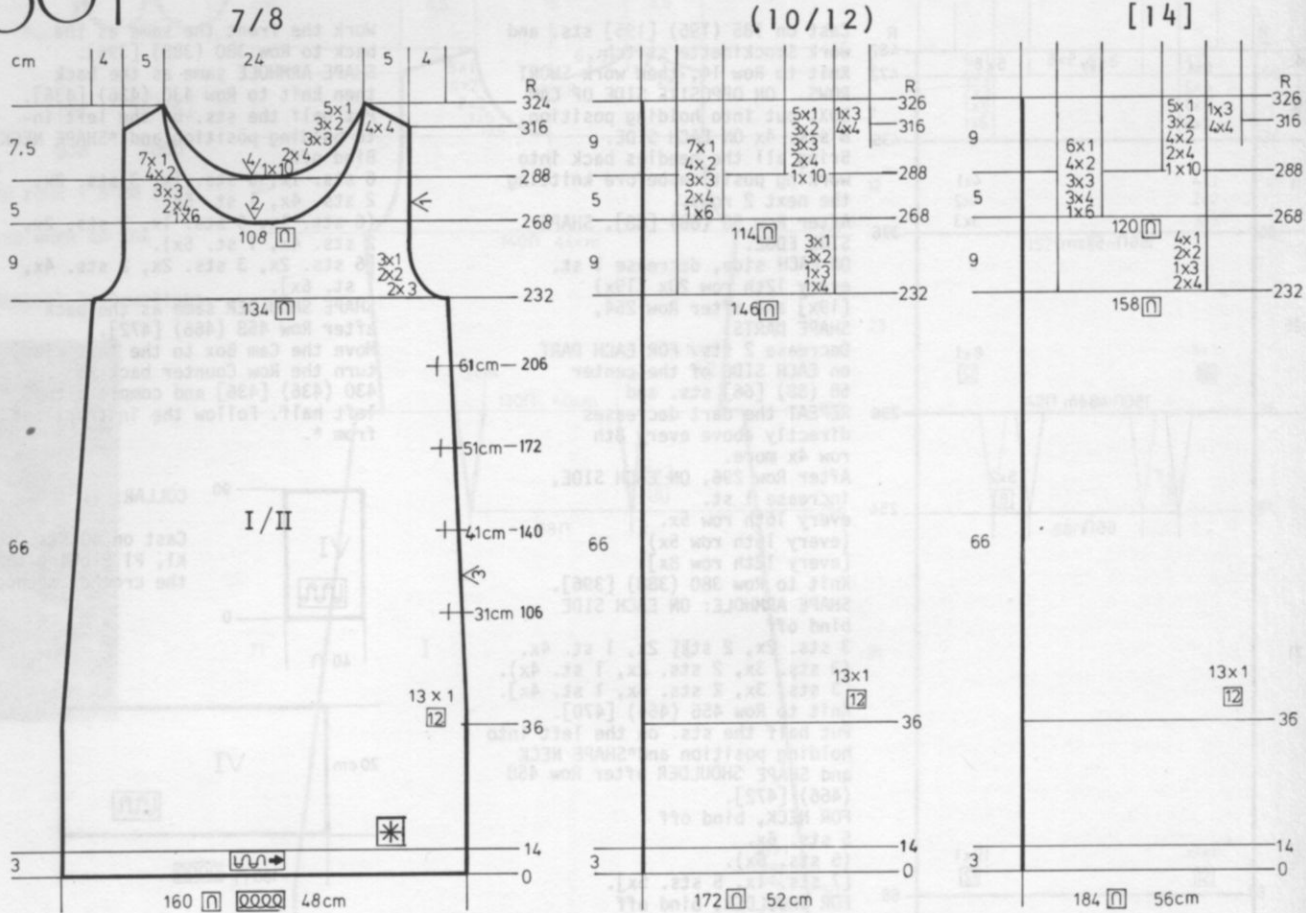

BACK: II

Cast on 160 (172) [184] sts. and work 14 rows Stockinette stitch. Change to the Norwegian Design. After Row 36, ON EACH SIDE, decrease 1 st. every 12th row 13x. Knit to Row 232. SHAPE ARMHOLE: ON EACH SIDE, bind off 3 sts. 2x, 2 sts. 2x, 1 st. 3x. (4 sts. 1x, 3 sts. 1x, 2 sts. 3x, 1 st. 3x). [4 sts. 2x, 3 sts. 1x, 2 sts. 2x, 1 st. 4x]. Knit to Row 288. SHAPE NECK: Put half the sts. on the left into holding position and *ON NECK SIDE, bind off

10 sts. 1x, 4 sts. 2x, 3 sts. 3x, 2 sts. 3x, 1 st. 5x. (10 sts. 1x, 4 sts. 2x, 3 sts. 3x, 2 sts. 3x, 1 st. 5x). 10 sts. 1x, 4 sts. 2x, 2 sts. 4x, 2 sts. 3x, 1 st. 5x). SHAPE SHOULDER after Row 316: Bind off 4 sts. 4x. (4 sts. 4x, 3 sts. 1x). [4 sts. 4x, 3 sts. 1x]. Bring the needles on the left into working position, knit 1 row in Pattern to the left side, turn the Row Counter back to 288 and complete the left half. Follow the instructions from *.

FRONT: I

Work the front the same as the back to Row 268. Put half the sts. on the left into holding position and complete the right side first. *ON NECK SIDE, bind off 6 sts. 1x, 4 sts. 2x, 3 sts. 3x, 2 sts. 4x, 1 st. 7x. (6 sts. 1x, 4 sts. 2x, 3 sts. 3x, 2 sts. 4x, 1 st. 7x). [6 sts. 1x, 4 sts. 3x, 3 sts. 3x, 2 sts. 4x, 1 st. 6x]. SHAPE SHOULDER same as the back after Row 316.

ARMBANDS: VIII Make 2.

Cast on 148 (154) [160] sts. and work Stockinette stitch. ON EVERY 2nd ROW, ON EACH SIDE, increase 1 st. 2x, then decrease 1 st. 2x. After Row 13, bind off.

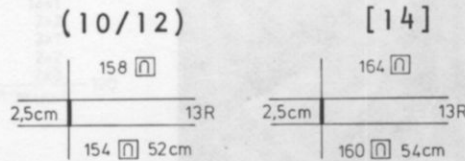
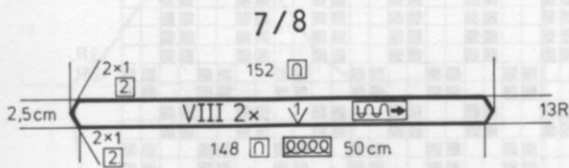

SIDE FRONT & BACK BANDS: VIII Make 4.

Cast on 197 sts. and work 26 rows Stockinette stitch, then bind off.

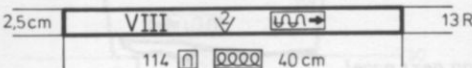
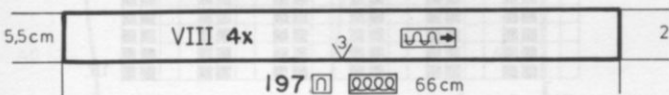

FRONT NECKBAND: VIII
Cast on 114 sts. and work 13 rows Stockinette stitch then bind off.

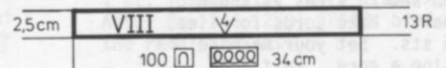

BACK NECKBAND: VIII
Cast on 100 sts. and work 13 rows Stockinette stitch then bind off.

NP 362

MAN'S PULLOVER

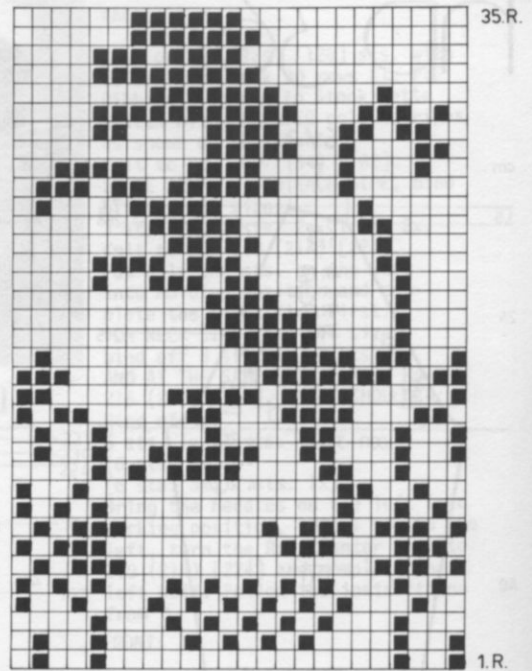

SIZES: 36/38 (40) [42]
 YARN: Allegro
 GRAMS:
 color 1 350 400 450
 color 2 100 150 200
 TENSION: 6 to 8
 GAUGE: 14 sts. 19 rows = 5 cm (2")

Stockinette stitch with color stripes and a Norwegian Design. The bands are Ribbed.

FINISHING: See General Instructions.

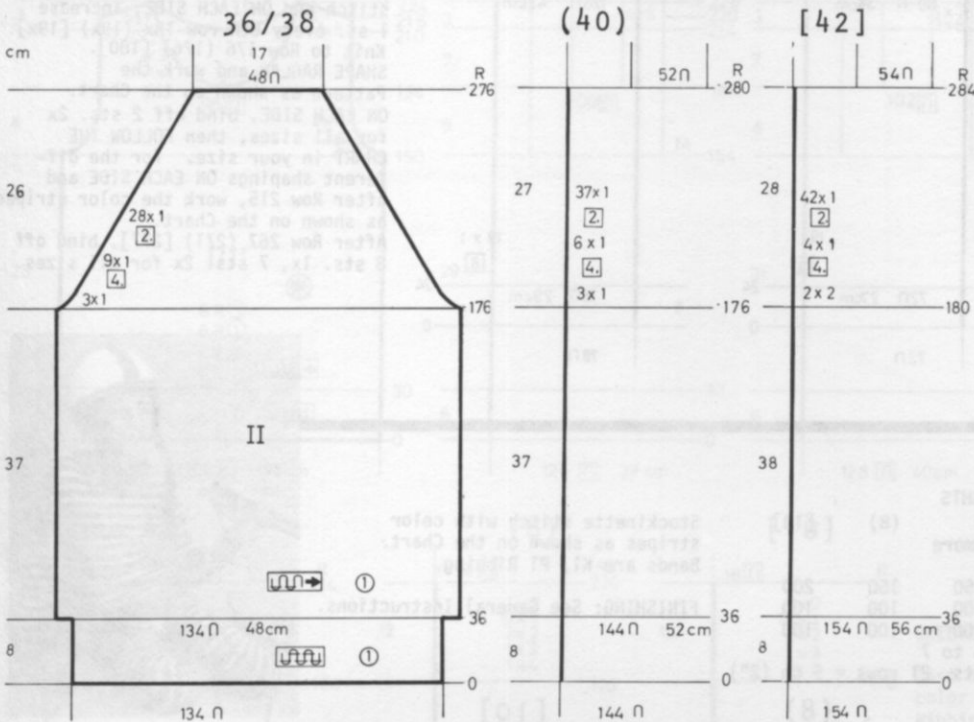

BACK: II

Cast on 134 (144) [154] sts. with color 1 and work 36 rows K1, P1 Ribbing. Change to Stockinette stitch and knit to Row 176 (176) [180]. Work the color stripes and Norwegian Design as shown on the FRONT Chart. Continue with color 1 and AT THE SAME TIME, SHAPE ARMHOLE: ON EACH SIDE, decrease 1 st. 3x (3x) [2x], then ON EVERY 4th row, decrease 1 st. 9x (6x) [4x], every 2nd row 1 st. 28x (37x) [42x]. After Row 276 (280) [284], bind off the remaining sts.

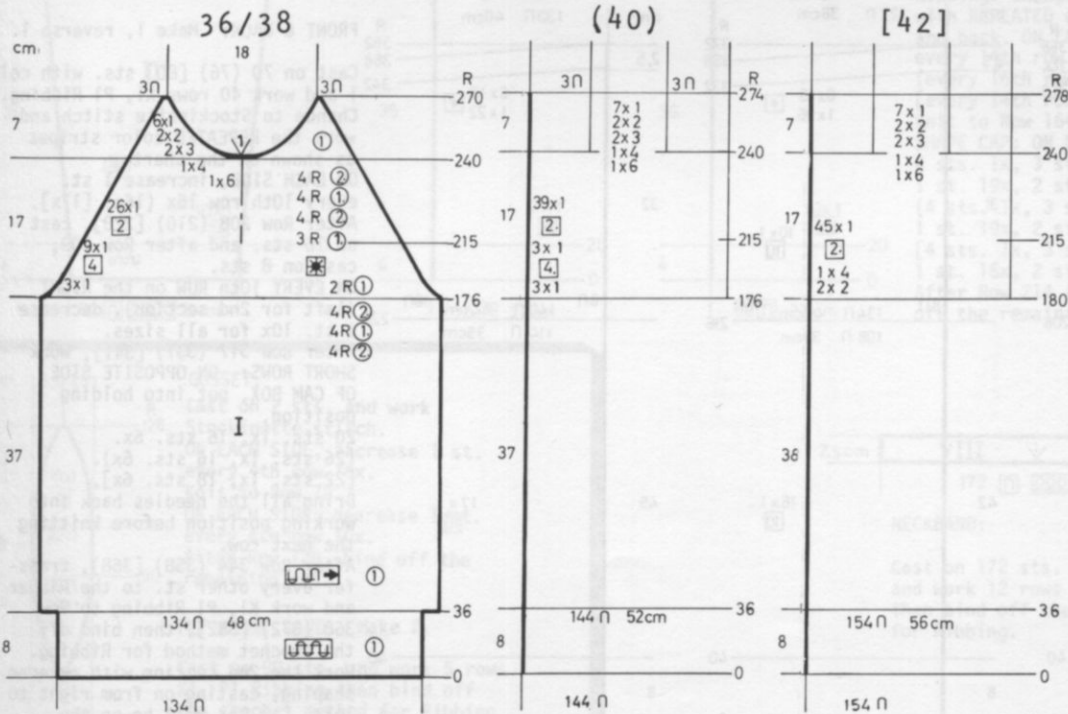

FRONT: I

Work the front the same as the back to Row 176 (176) [180]. Work the color stripes as shown on the Chart followed by the Norwegian Design with color stripes and AT THE SAME TIME SHAPE ARMHOLE: ON EACH SIDE, decrease 1 st. 3x (3x) [2x, 4 sts. 1x]. ON EVERY 4th row, decrease 1 st. 9x (3x) [0x] and on every 2nd row, decrease 1 st. 26x (39x) [45x], AND AT THE SAME TIME, After Row 240 SHAPE NECK: Put half the sts. on the left into holding position and complete the right side first. *ON NECK SIDE, bind off 6 sts. 1x, 4 sts. 1x, 3 sts. 2x, 2 sts. 2x, 1 st. 6x. (6 sts. 1x, 4 sts. 1x, 3 sts. 2x, 2 sts. 2x, 1 st. 7x). [6 sts. 1x, 4 sts. 1x, 3 sts. 2x, 2 sts. 2x, 1 st. 7x]. After Row 270 (274) [278], bind off the remaining sts. Bring the needles on the left into working position, knit 1 row to the left side, turn the Row Counter back to 240 and complete the left half. Follow the instructions from *.

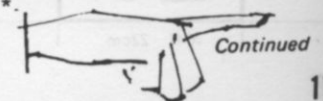

np 362

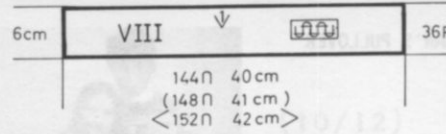

NECKBAND: VIII
Cast on 144 (148) [152] sts. with color 1 and work 36 rows K1, P1 Ribbing. Change to Stockinette stitch and ON EACH SIDE, increase 1 st. every 8th row 18x (19x) [19x]. Knit to Row 176 (176) [180].

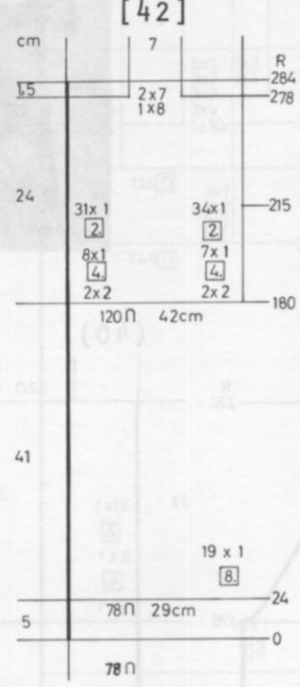
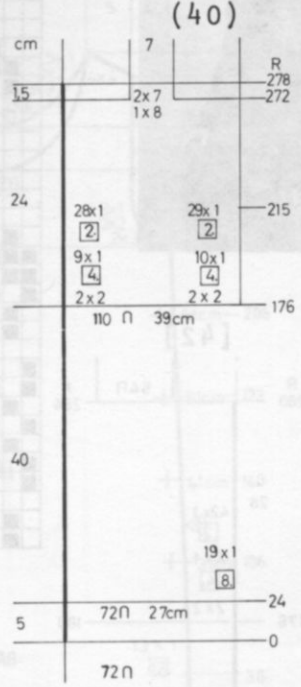
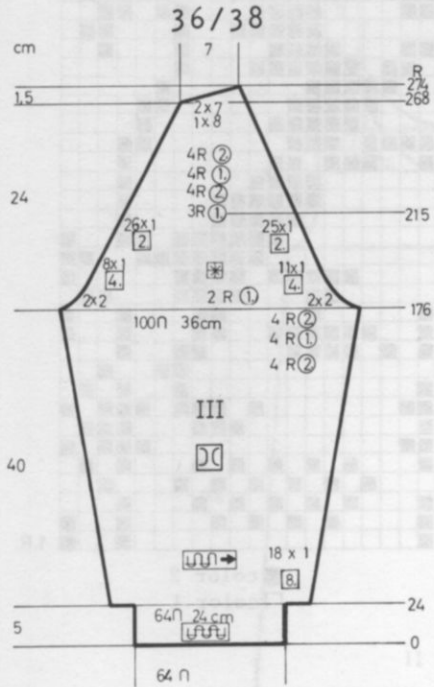

SLEEVES: III Make 1, reverse 1.
Cast on 64 (72) [78] sts. with color 1 and work 24 rows K1, P1 Ribbing. Change to Stockinette stitch and ON EACH SIDE, increase 1 st. every 8th row 18x (19x) [19x]. Knit to Row 176 (176) [180]. SHAPE RAGLAN and work the Pattern as shown on the Chart. ON EACH SIDE, bind off 2 sts. 2x for all sizes, then FOLLOW THE CHART in your size. for the different shapings ON EACH SIDE and after Row 215, work the color stripes as shown on the Chart. After Row 267 (271) [277], bind off 8 sts. 1x, 7 sts. 2x for all sizes.

kk 363

CHILD'S TIGHTS
SIZES: 6 (8) [10]
YARN: Amore
GRAMS:
color 1 150 150 200
color 2 100 100 100
color 3 100 100 100
TENSION: 5 to 7
GAUGE: 16 sts. 21 rows = 5 cm (2")

Stockinette stitch with color stripes as shown on the Chart. Bands are K1, P1 Ribbing.
FINISHING: See General Instructions.

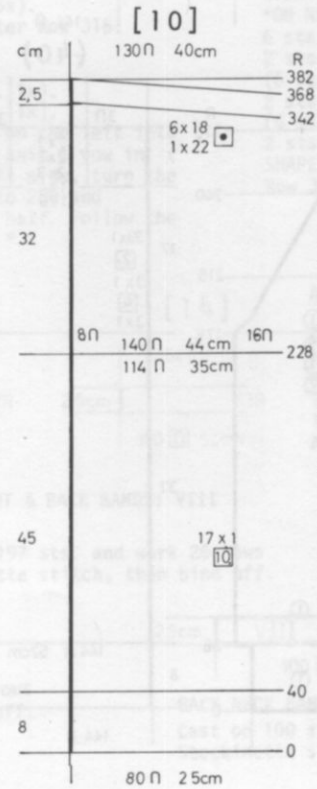
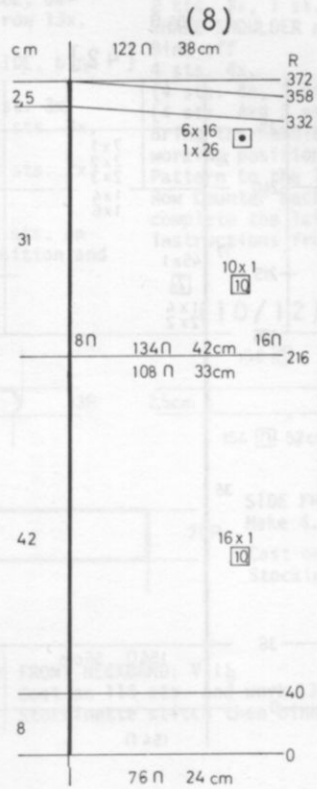
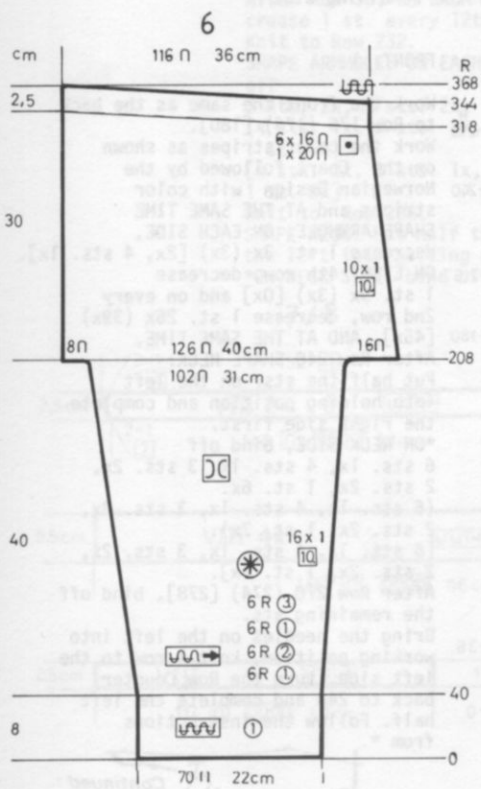

FRONT & BACK: Make 1, reverse 1.
Cast on 70 (76) [80] sts. with color 1 and work 40 rows K1, P1 Ribbing. Change to Stockinette stitch and work the REPEATED color stripes as shown on the Chart. ON EACH SIDE, increase 1 st. every 10th row 16x (16x) [17x]. After Row 208 (216) [228], cast on 16 sts. and after Row 209, cast on 8 sts. ON EVERY 10th ROW on the RIGHT (left for 2nd section), decrease 1 st. 10x for all sizes. After Row 317 (331) [341], work SHORT ROWS: ON OPPOSITE SIDE OF CAM BOX, put into holding position, 20 sts. 1x, 16 sts. 6x. (26 sts. 1x, 16 sts. 6x). [22 sts. 1x, 18 sts. 6x]. Bring all the needles back into working position before knitting the next row. After Row 344 (358) [368], transfer every other st. to the Ribber and work K1, P1 Ribbing to Row 368 (372) [382], then bind off the crochet method for Ribbing. Work the 2nd section with reverse shaping, casting on from right to left. Cam Box will be on the left side at Row 0.

KK 364

CHILD'S PULLOVER

SIZES: 6 (8) [10]
YARN: Amore
GRAMS:
 color 1 100 150 150
 color 2 100 100 100
 color 3 100 100 100
TENSION: 5 to 7
GAUGE: 16 sts. 21 rows = 5 cm (2")

Stockinette stitch with color stripes as shown on the Chart.
 Bands are K1, P1 Ribbing.

FINISHING: See General Instructions.



BACK: II

Cast on 120 (124) [128] sts. with color 1 and work 30 rows K1, P1 Ribbing. Change to Stockinette stitch with REPEATED color stripes as shown on the Chart.
 Knit to Row 150- (154) [162].
SHAPE ARMHOLE: ON EACH SIDE, bind off for all sizes,
 3 sts. 2x, 2 sts. 2x, 1 st. 2x.
 Knit to Row 210 (214) [224].
 Put half the sts. on the left into holding position and complete the right side first.
 *ON NECK SIDE, for all sizes, bind off 8 sts. 1x, 3 sts. 6x AND AT THE SAME TIME, after Row 216 (220) [230], SHAPE SHOULDER:
 Bind off

6 sts. 1x, 4 sts. 1x.
 (6 sts. 4x).
 [6 sts. 3x, 7 sts. 1x].
 Bring the needles on the left into working position, knit 1 row to the left, turn the Row Counter back to 210 (214) [224] and complete the left half. Follow the instructions from *.

FRONT: I

Work the front the same as the back to Row 184 (188) [196].
 Put half the sts. on the left into holding position and complete the right side first.

*ON NECK SIDE, for all sizes, bind off 5 sts. 1x, 4 sts. 1x, 3 sts. 2x, 2 sts. 4x, 1 st. 3x and SHAPE SHOULDER same as the back after Row 216 (220) [230].
 Bring the needles on the left into working position, knit 1 row to the left side, turn the Row Counter back to 184 (188) [196] and complete the left half. Follow the instructions from *.

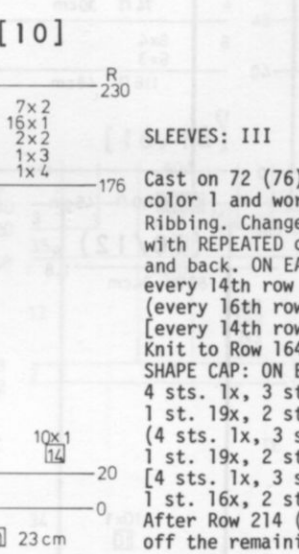
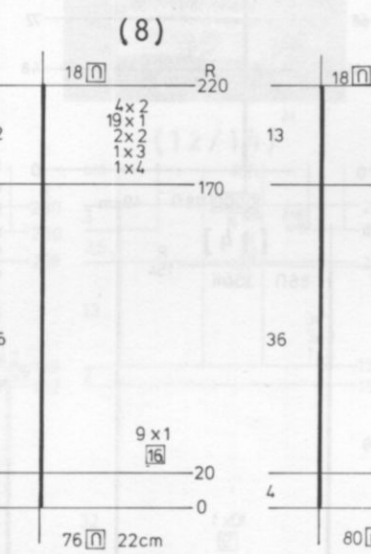
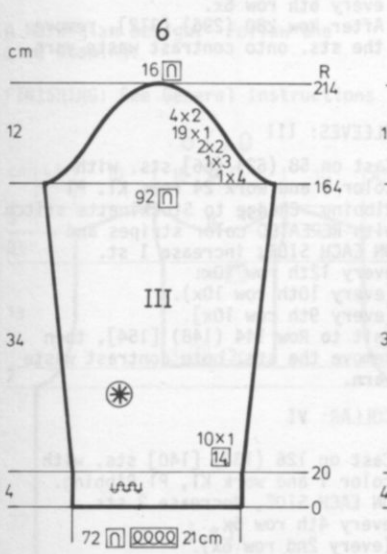
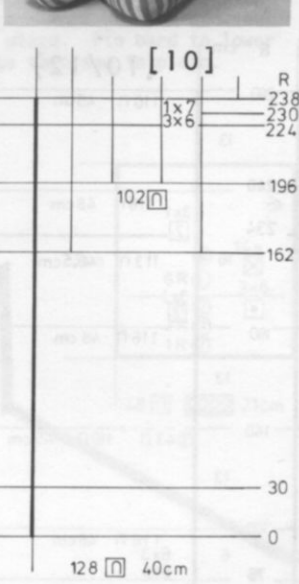
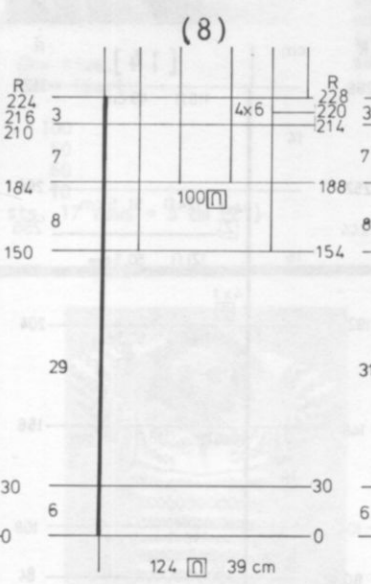
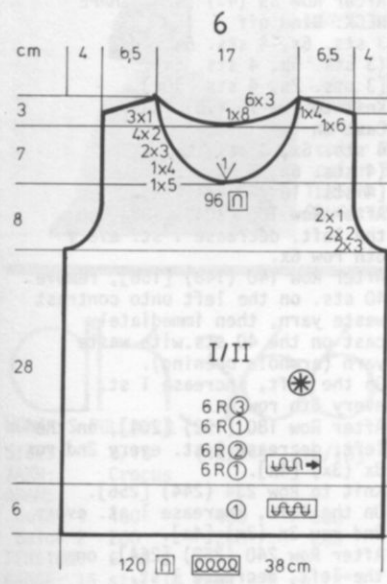

SLEEVES: III

Cast on 72 (76) [80] sts. with color 1 and work 20 rows K1, P1 Ribbing. Change to Stockinette stitch with REPEATED color stripes as on front and back. ON EACH SIDE, increase 1 st. every 14th row 10x.
 (every 16th row 9x).
 [every 14th row 10x].
 Knit to Row 164 (170) [176].
SHAPE CAP: ON EACH SIDE, bind off
 4 sts. 1x, 3 sts. 1x, 2 sts. 2x, 1 st. 19x, 2 sts. 4x.
 (4 sts. 1x, 3 sts. 1x, 2 sts. 2x, 1 st. 19x, 2 sts. 4x).
 [4 sts. 1x, 3 sts. 1x, 2 sts. 2x, 1 st. 16x, 2 sts. 7x].
 After Row 214 (220) [230], bind off the remaining sts.

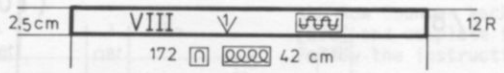
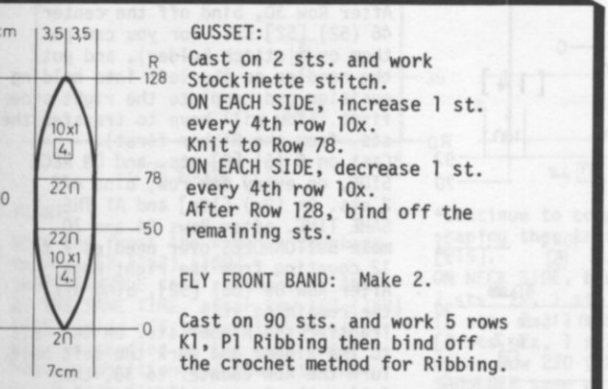

NECKBAND:

Cast on 172 sts. with color 1 and work 12 rows K1, P1 Ribbing then bind off the crochet method for Ribbing.

KK 365

BOY'S PULLOVER

SIZES: 7/8 (10/12) [14]
 YARN: Euro Sport
 GRAMS:
 color 1 250 300 350
 color 2 100 150 150
 color 3 50 100 100
 TENSION: 10
 GAUGE: 12 sts. 17 rows = 5 cm (2")

Stockinette stitch with REPEATED color stripes. Knitted sideways on the machine. The purl side is the right side. Bands are K1, P1 Ribbing.

FINISHING: See General Instructions. Sew sleeve seams, then weave the open sts. to the open sts. of sleeve opening on Pullover.



FRONT & BACK:

Open Cast-on. With contrast waste yarn, cast on 104 (110) [118] sts. and work Stockinette stitch. Knit 8 to 10 rows then change to garment yarn and Counter at 0. Continue in Stockinette stitch with REPEATED color stripes as shown on the Chart.

On the left, increase 1 st. every 6th row 6x.

After Row 39 (43) [47], SHAPE

NECK: Bind off

3 sts. 6x, 4 sts. 6x.

(3 sts. 6x, 4 sts. 6x).

[3 sts. 2x, 4 sts. 10x].

Knit to Row 75 (79) [83].

Cast on

4 sts. 6x, 3 sts. 6x.

(4 sts. 6x, 3 sts. 6x).

[4 sts. 10x, 3 sts. 2x].

After Row 100 (104) [108], on the left, decrease 1 st. every 6th row 6x.

After Row 140 (148) [156], remove 40 sts. on the left onto contrast waste yarn, then immediately cast on the 40 sts. with waste yarn (armhole opening).

On the left, increase 1 st. every 6th row 6x.

After Row 180 (192) [204], on the left, decrease 1 st. every 2nd row 3x (3x) [4x].

Knit to Row 234 (244) [256].

On the left, increase 1 st. every 2nd row 3x (3x) [4x].

After Row 240 (252) [264], on the left, decrease 1 st. every 6th row 6x.

After Row 280 (296) [312], remove the sts. onto contrast waste yarn.

SLEEVES: III

Cast on 58 (62) [66] sts. with color 1 and work 24 rows K1, P1 Ribbing. Change to Stockinette stitch with REPEATED color stripes and ON EACH SIDE, increase 1 st. every 12th row 10x. (every 10th row 10x). [every 9th row 10x]. Knit to Row 144 (148) [154], then remove the sts. onto contrast waste yarn.

COLLAR: VI

Cast on 126 (134) [140] sts. with color 1 and work K1, P1 Ribbing. ON EACH SIDE, decrease 2 sts. every 4th row 6x. (every 2nd row 6x). [every 4th row 6x].

After Row 30, bind off the center 46 (52) [52] sts. (or you can put them on a stitch holder), and put the needles on the left into holding position and complete the right side first. (You will have to transfer the sts. from the Ribber first).

*Cast on 6 (6) [8] sts. and ON NECK SIDE, on every 6th row, bind off 2 sts. 9x (9x) [10x] and AT THE SAME TIME, after Rows 54 and 70, make BUTTONHOLES over needles 7 to 12 counting from the right edge. After Row 86 (86) [92], bind off the remaining sts. Transfer the Ribber sts. on the left to the Ribber and work the left half. Turn the Row Counter to 30, then follow the instructions from * but omit the buttonholes.

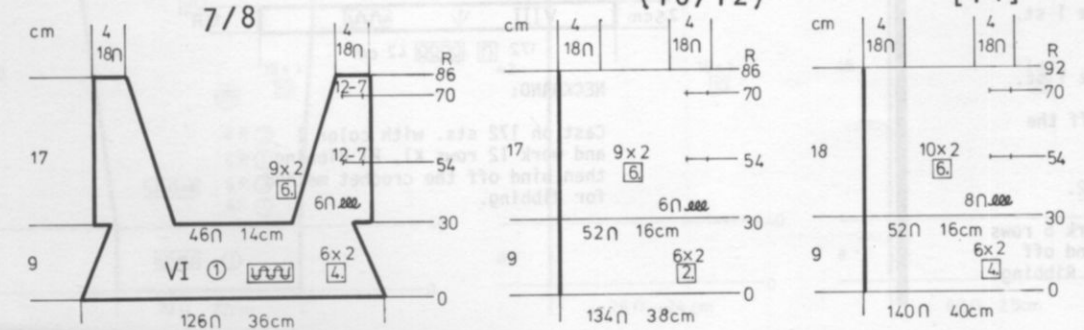
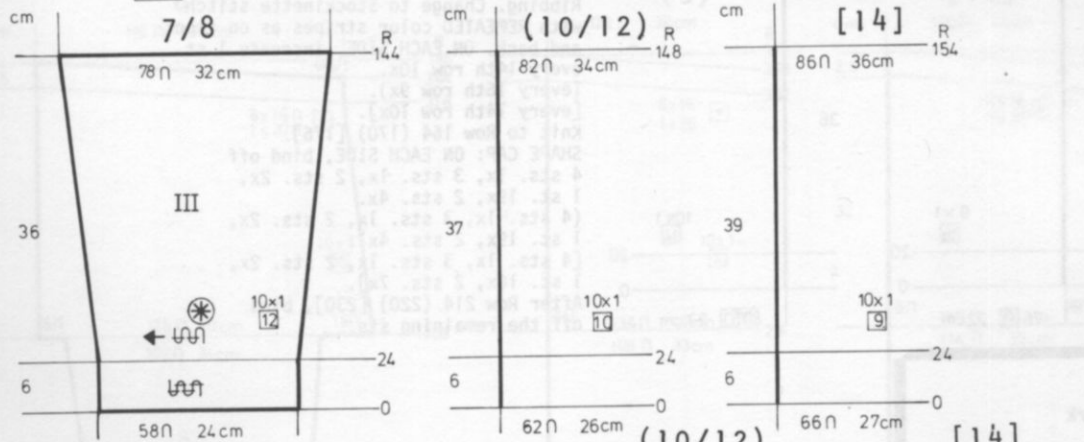
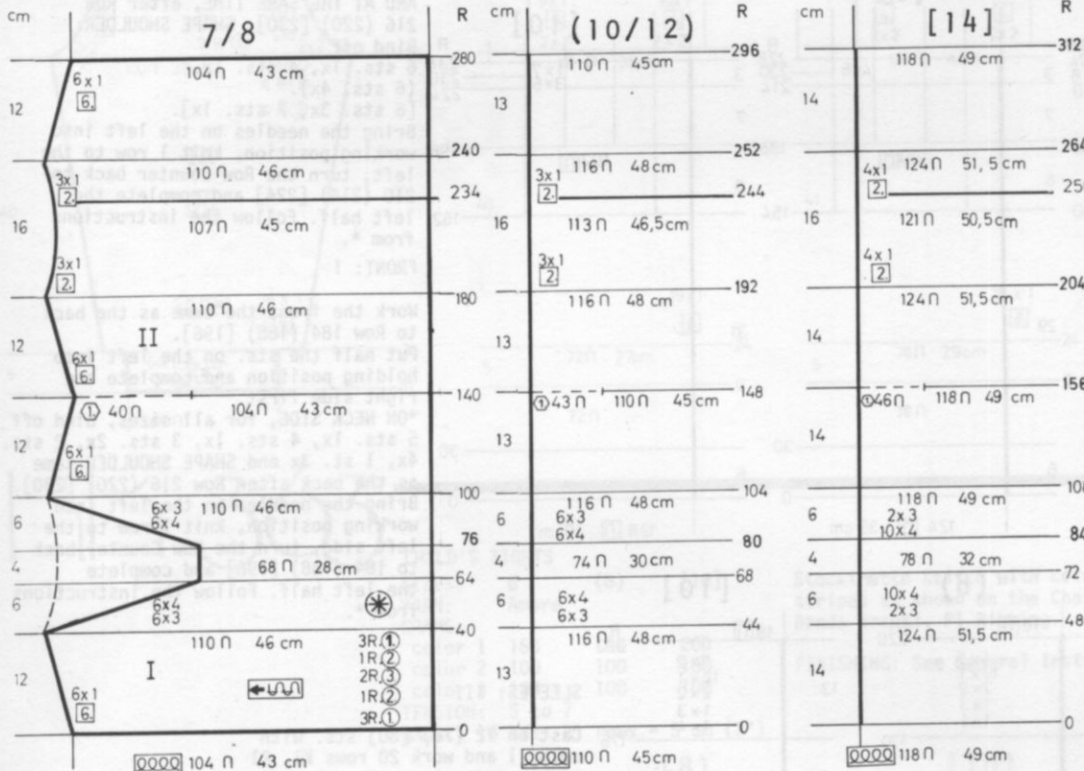

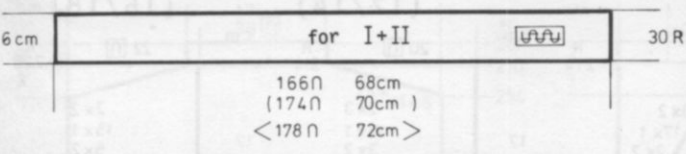

LOWER BAND:
Cast on 166 (174) [178] sts. and work 30 rows K1, P1 Ribbing then bind off the crochet method for Ribbing.

KK 367



BOY'S HAT
SIZE: One size.
YARN: Euro Sport
GRAMS:
color 1 100
color 2 50
color 3 50
TENSION: 10
GAUGE: 12 sts. 17 rows = 5 cm (2")

Stockinette stitch with color stripes and Short Rows as shown on the Chart. Band is K1, P1 Ribbing.

FINISHING: Weave the open sts. held on waste yarn then remove the waste yarn. Gather top edge. Make pom pom and sew in place. Pin band to lower edge then, sew in place.

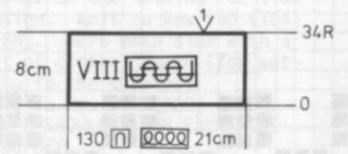

BAND: VIII
Cast on 130 sts. and with tension 10, work 34 rows, K1, P1 Ribbing then bind off the crochet method for Ribbing.

dk 366

WOMAN'S PULLOVER
SIZES: 8/10 (12/14) [16/18]
YARN: Crocus
GRAMS:
color 1 400 450 500
color 2 200 200 200
TENSION: 6 to 8
GAUGE: 15 sts. 18 rows = 5 cm (2")



A Norwegian Design. Follow the Line Drawing.
FINISHING: See General Instructions

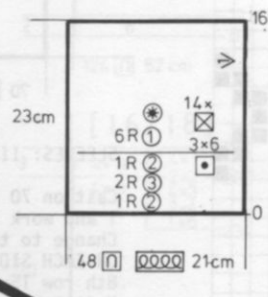

160 R With contrast waste yarn, cast on 48 sts. Knit 8 to 10 rows, then change to garment yarn. Work Stockinette stitch with color stripes as shown on the Chart and AT THE SAME TIME, work SHORT ROWS after Row 4. ON OPPOSITE SIDE OF CAM BOX, put into holding position 6 sts. 3x. After Row 10, bring all the needles back into working position and continue with the color stripes. REPEAT THESE SHORT ROWS each time you work the 6 rows of color 1 - 13x more.
After Row 160, remove the sts. onto contrast waste yarn.

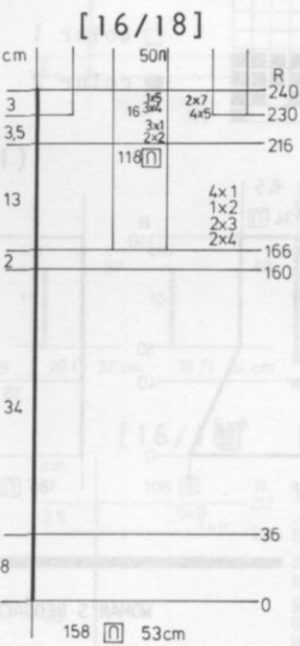
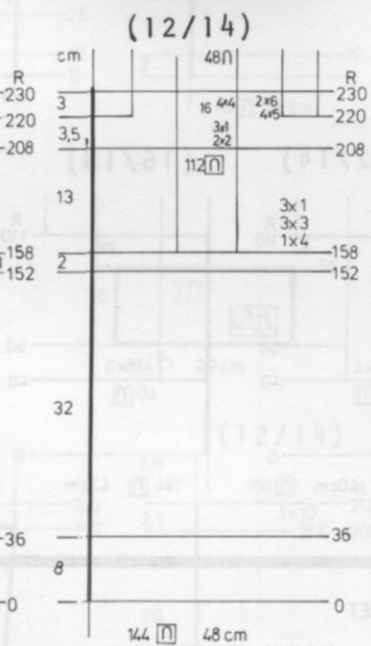
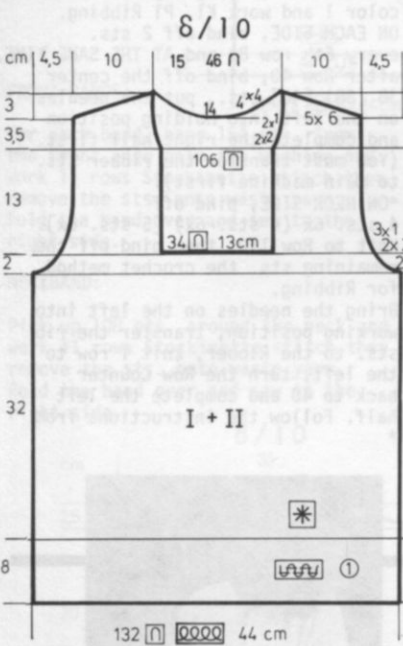

BACK: II
Cast on 132 (144) [158] sts. with color 1 and work 36 rows K1, P1 Ribbing. Change to the Norwegian Design. Knit to Row 152 (152) [160].
SHAPE ARMHOLE: ON EACH SIDE, bind off
3 sts. 2x, 2 sts. 2x, 1 st. 3x. (4 sts. 1x, 3 sts. 3x, 1 st. 3x). [4 sts. 2x, 3 sts. 2x, 2 sts. 1x, 1 st. 4x].
Knit to Row 220 (220) [230]. Bind off the center 14 (16) [16] sts., put the needles on the left into holding position and complete the right half first.
***SHAPE SHOULDER AND NECK AT THE SAME TIME.**
FOR SHOULDER, bind off
6 sts. 5x.
(5 sts. 4x, 6 sts. 2x).
[5 sts. 4x, 7 sts. 2x].
FOR NECK, bind off
4 sts. 4x.
(4 sts. 4x).
[4 sts. 3x, 5 sts. 1x].
Bring the needles on the left into working position, knit 1 row in Pattern to the left side, turn the Row Counter back to 220 (220) [230] and complete the left half. Follow the instructions from *.

FRONT: I
Work the front the same as the back to Row 152 (152) [160].
SHAPE ARMHOLE same as the back AND AT THE SAME TIME, after Row 158 (158) [166], bind off the center 34 sts., put the needles on the left into holding position and complete the right side first.

*Continue to complete the armhole shaping then knit to Row 207 (207) [215].
ON NECK SIDE, bind off
2 sts. 2x, 1 st. 2x.
(2 sts. 2x, 1 st. 3x).
[2 sts. 2x, 1 st. 3x].
After Row 220 (220) [230], **SHAPE SHOULDER** same as the back.

Bring the needles on the left into working position, knit 1 row in Pattern to the left side, turn the Row Counter back to 158 (158) [166] and complete the left half. Follow the instructions from *.



dk 366

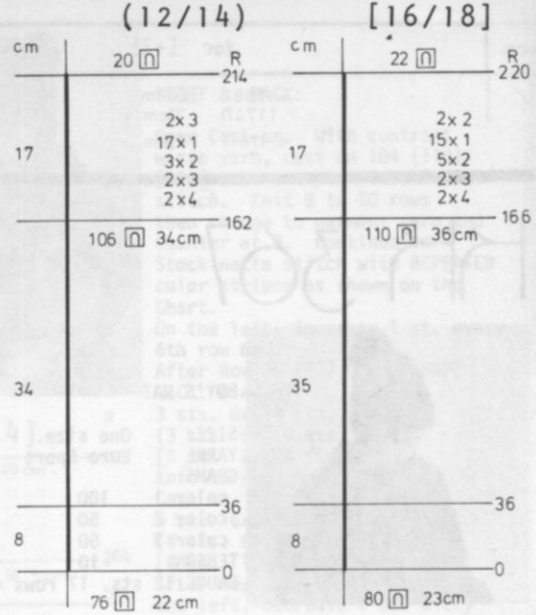
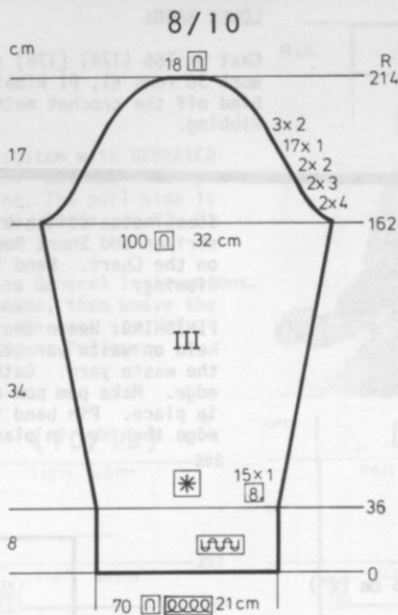
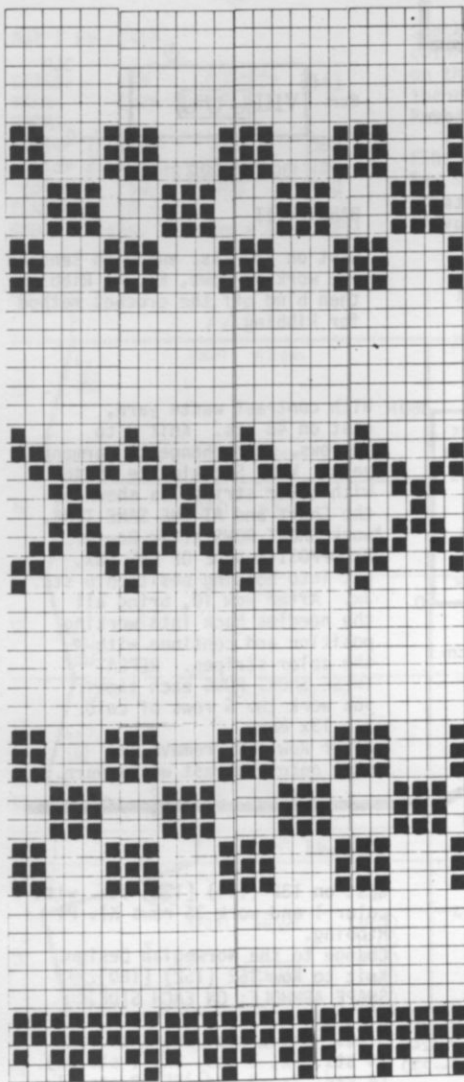

SLEEVES: III

Cast on 70 (76) [80] sts. with color 1 and work 36 rows K1, P1 Ribbing. Change to the Norwegian Design and ON EACH SIDE, increase 1 st. every 8th row 15x. Knit to Row 162 (162) [166].
 SHAPE CAP: ON EACH SIDE, bind off 4 sts. 2x, 3 sts. 2x, 2 sts. 2x, 1 st. 17x, 2 sts. 3x. (4 sts. 2x, 3 sts. 2x, 2 sts. 3x, 1 st. 17x, 3 sts. 2x). [4 sts. 2x, 3 sts. 2x, 2 sts. 5x, 1 st. 15x, 2 sts. 2x]. After Row 214 (214) [220] bind off the remaining sts.

□ color 1
 ■ color 2

COLLAR: VI

Cast on 186 (186) [194] sts. with color 1 and work K1, P1 Ribbing. ON EACH SIDE, bind off 2 sts. every 6th row 8x and AT THE SAME TIME, after Row 40, bind off the center 38 (38) [40] sts., put the needles on the left into holding position and complete the right half first. (You must transfer the ribber sts. to main machine first).
 *ON NECK SIDE, bind off 4 sts. 6x (4 sts. 6x) [5 sts. 6x]. Knit to Row 110, then bind off the remaining sts. the crochet method for Ribbing. Bring the needles on the left into working position, transfer the rib sts. to the Ribber, knit 1 row to the left, turn the Row Counter back to 40 and complete the left half. Follow the instructions from *

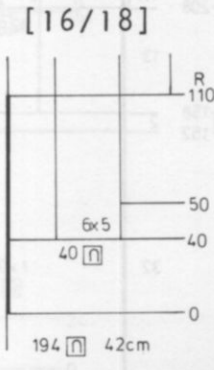
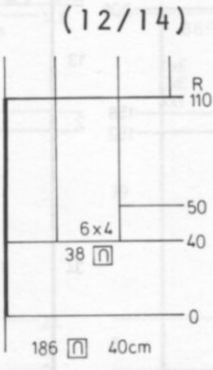
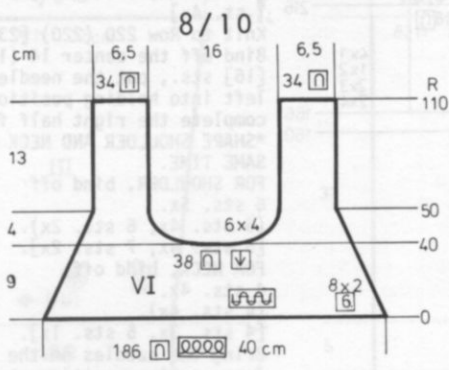

dk 368

WOMAN'S BEDJACKET

SIZES: 8/10 (12/14) [16/18]
 YARN: Cheri
 GRAMS: 1 Cone
 TENSION: 4 to 6
 GAUGE: 12 sts. 25 rows = 5 cm (2")



A Holding Position Design worn on the Purl side.

FINISHING: See General Instructions.



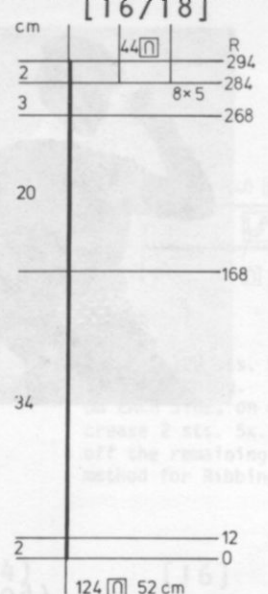
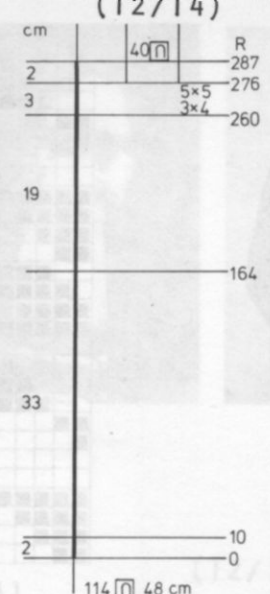
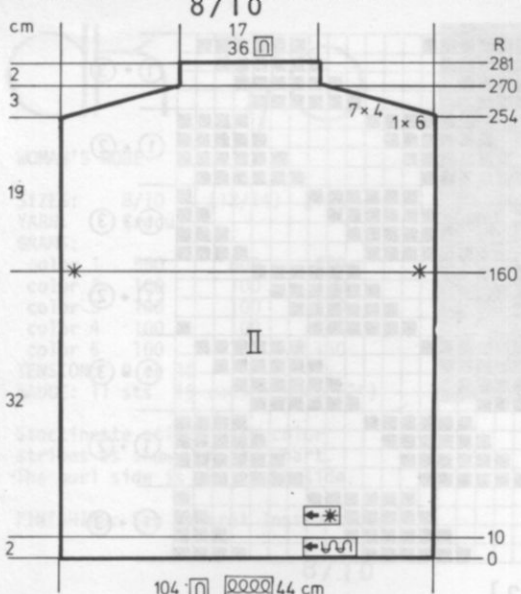

BACK: II

Cast on 104 (114) [124] sts. and work 10 rows Stockinette stitch. Change to the Holding Position Design. Knit to Row 160 (164) [168]. Mark each side with a bit of contrast yarn (for setting in the sleeves). Knit to Row 254 (260) [268]. SHAPE SHOULDER: ON EACH SIDE bind off 6 sts. 1x, 4 sts. 7x. (4 sts. 3x, 5 sts. 5x). [5 sts. 8x]. Knit to Row 281 (287) [294] then bind off the remaining sts.

FRONT: I Make 1, reverse 1 and omit the buttonholes.

Cast on 58 (68) [78] sts. and work 10 rows Stockinette stitch. Change to the Holding Position Design.

MAKE BUTTONHOLES over needles 5 to 8 counting from the right edge after the rows shown on the Chart, and after Row 160 (164) [168], mark the left (right for 2nd section) edge with a bit of contrast waste yarn. After Row 230 (234) [234], SHAPE NECK, and AT THE SAME TIME, watch for SHOULDER SHAPING. ON NECK SIDE, bind off 6 sts. 1x, 4 sts. 1x, 3 sts. 2x, 2 sts. 2x, 1 st. 4x. (6 sts. 1x, 4 sts. 1x, 3 sts. 2x, 2 sts. 2x, 1 st. 4x). [6 sts. 1x, 4 sts. 2x, 3 sts. 4x, 2 sts. 2x, 1 st. 4x]. After Row 255 (261) [261], SHAPE SHOULDER: Bind off 6 sts. 1x, 4 sts. 7x. (4 sts. 3x, 5 sts. 5x). [5 sts. 4x, 6 sts. 4x]. Work the 2nd section with reverse shaping, and omit the buttonholes.

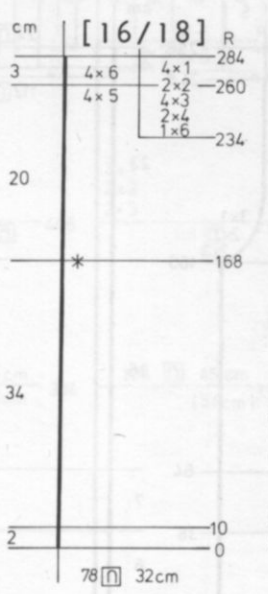
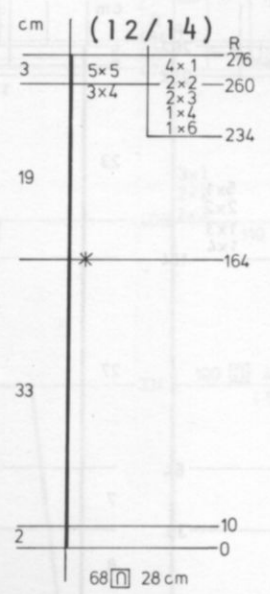
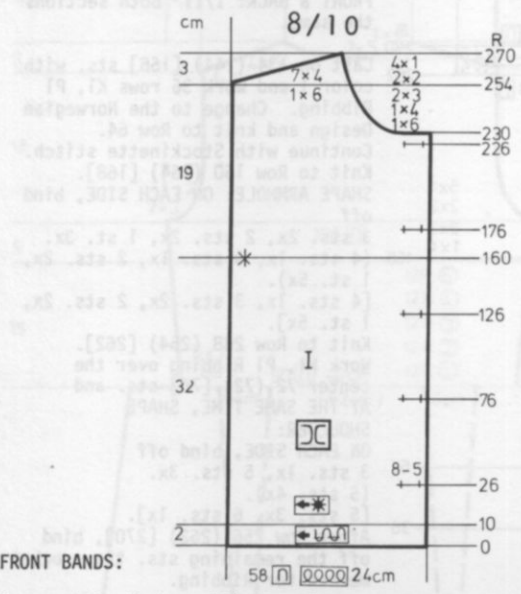

FRONT BANDS:

For each band, hang 154 sts. from the front edge onto the machine and work 11 rows Stockinette stitch then remove the sts. onto waste yarn. Fold the band over and sew to the right side.

NECKBAND:

Pick up 108 sts. around the neck and work 11 rows Stockinette stitch then remove the sts. onto waste yarn. Fold the band over and sew to the right side.

SLEEVE CUFFS: III

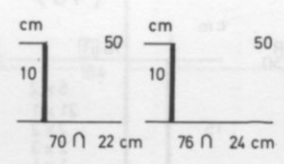
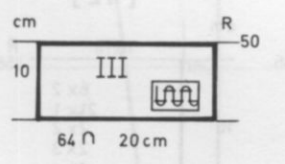

Hang the open sts. of the sleeve onto the machine, decreasing to 64 (70) [76] sts. Remove the waste yarn. Transfer every other stitch to the Ribber and work 50 rows K1, P1 Ribbing then bind off the crochet method for Ribbing.

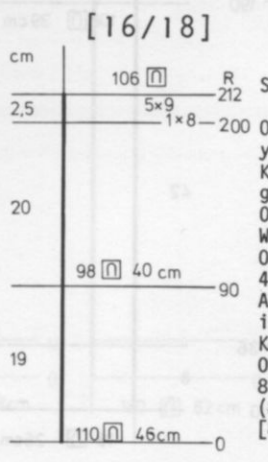
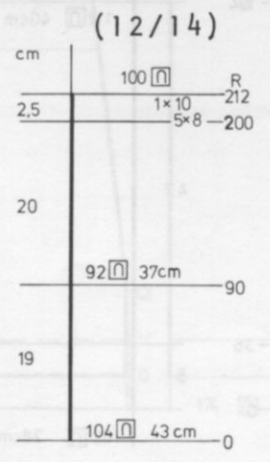
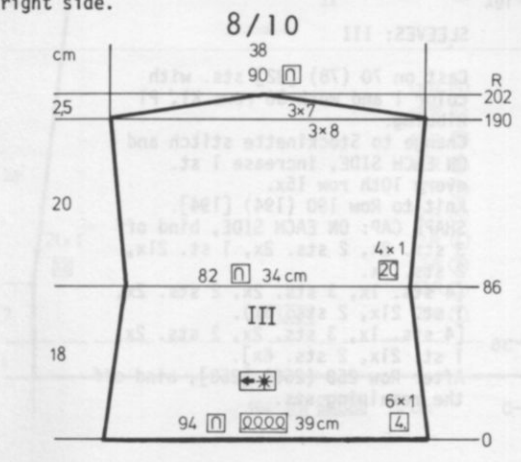

SLEEVES: III

OPEN CAST ON. With contrast waste yarn, cast on 94 (104) [110] sts. Knit 8 to 10 rows, then change to garment yarn and put the Counter at 0. Work in the Holding Position Design. ON EACH SIDE, decrease 1 st. every 4th row 6x. After Row 86 (90) [90], ON EACH SIDE, increase 1 st. every 20th row 4x. Knit to Row 190 (200) [200]. ON EACH SIDE, bind off 8 sts. 3x, 7 sts. 3x. (8 sts. 5x, 10 sts. 1x). [8 sts. 1x, 9 sts. 5x].

hp 369

MAN'S PULLOVER

SIZES: 36/38 (40) [42]

YARN: Binia

GRAMS:

color 1	350	400	450
color 2	50	100	100
color 3	50	100	100

TENSION: 7 to 9

GAUGE: 14 sts. 19 rows = 5 cm (2")

Stockinette stitch with a Norwegian Design Border. The bands are Ribbed.

FINISHING: See General Instructions.

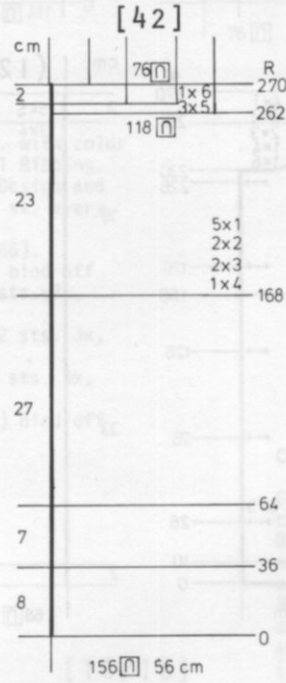
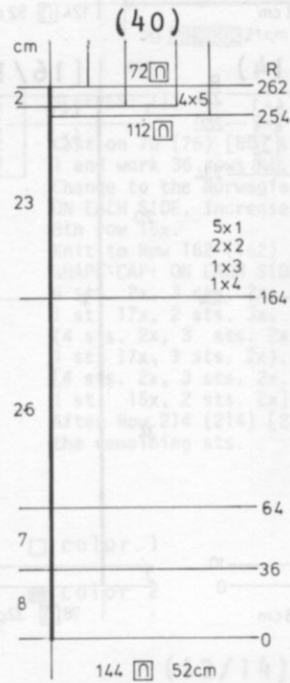
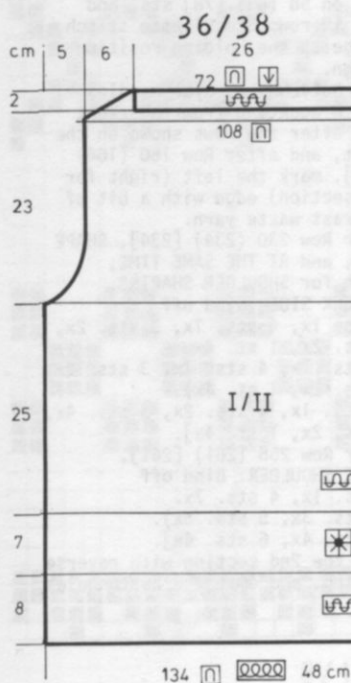
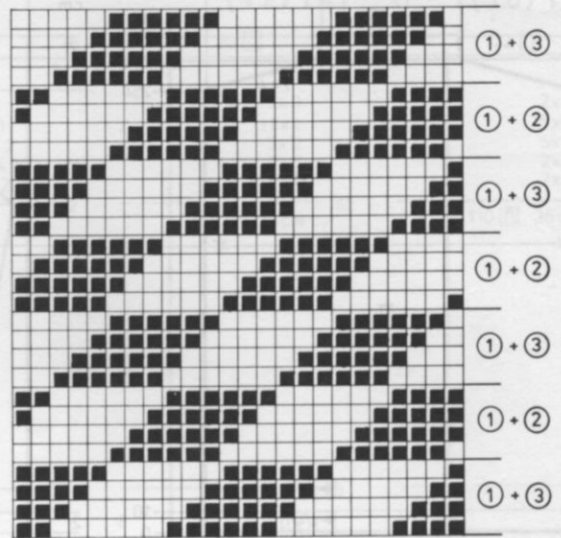

FRONT & BACK: I/II Both sections the same.

Cast on 134 (144) [156] sts. with color 1 and work 36 rows K1, P1 Ribbing. Change to the Norwegian Design and knit to Row 64.

Continue with Stockinette stitch. Knit to Row 160 (164) [168].

SHAPE ARMHOLE: ON EACH SIDE, bind off 3 sts. 2x, 2 sts. 2x, 1 st. 3x. (4 sts. 1x, 3 sts. 1x, 2 sts. 2x, 1 st. 5x).

[4 sts. 1x, 3 sts. 2x, 2 sts. 2x, 1 st. 5x].

Knit to Row 248 (254) [262]. Work K1, P1 Ribbing over the center 72 (72) [76] sts. and AT THE SAME TIME, SHAPE SHOULDER:

ON EACH SIDE, bind off 3 sts. 1x, 5 sts. 3x. (5 sts. 4x).

[5 sts. 3x, 6 sts. 1x].

After Row 256 (262) [270], bind off the remaining sts. the crochet method for Ribbing.

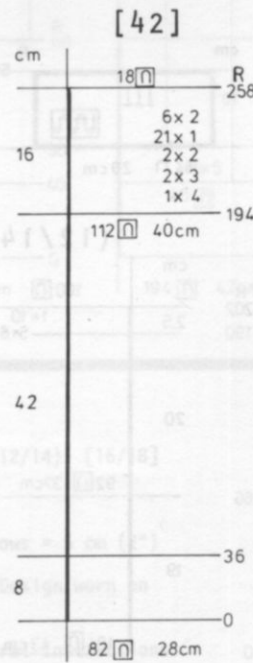
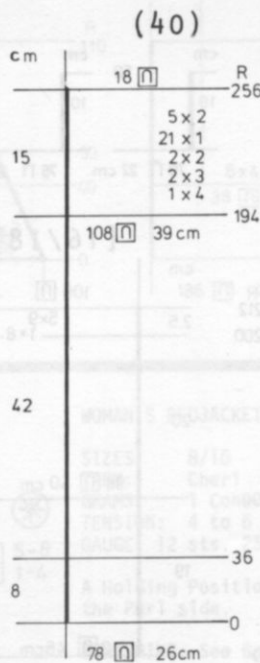
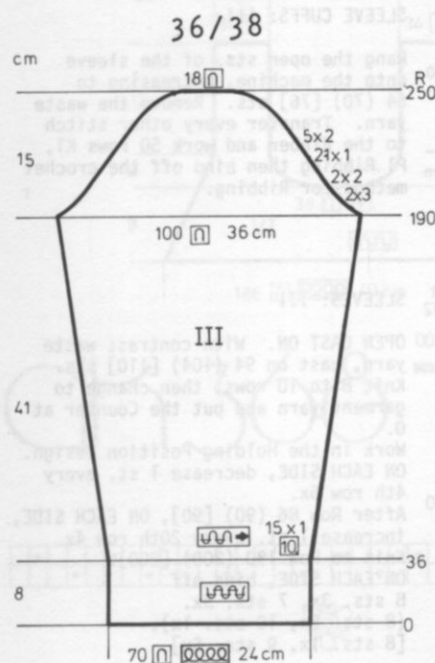

SLEEVES: III

Cast on 70 (78) [82] sts. with color 1 and work 36 rows K1, P1 Ribbing.

Change to Stockinette stitch and ON EACH SIDE, increase 1 st. every 10th row 15x.

Knit to Row 190 (194) [194].

SHAPE CAP: ON EACH SIDE, bind off 3 sts. 2x, 2 sts. 2x, 1 st. 21x, 2 sts. 5x.

(4 sts. 1x, 3 sts. 2x, 2 sts. 2x, 1 st. 21x, 2 sts. 5x).

[4 sts. 1x, 3 sts. 2x, 2 sts. 2x, 1 st. 21x, 2 sts. 6x].

After Row 250 (256) [258], bind off the remaining sts.

dk 370

WOMAN'S ROBE

SIZES: 8/10 (12/14) [16]
 YARN: Crocus

GRAMS:
 color 1 550 600 650
 color 2 100 100 150
 color 3 100 100 150
 color 4 100 100 150
 color 5 100 100 150

TENSION: 9 or 10
 GAUGE: 11 sts. 18 rows = 5 cm (2")



Stockinette stitch with color stripes as shown on the Chart. The purl side is the right side.

FINISHING: See General Instructions.

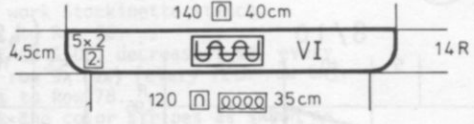

COLLAR: VI

Cast on 120 sts. with color 1 and work K1, P1 Ribbing.
 ON EACH SIDE, on every 2nd row, decrease 2 sts. 5x. After Row 14, bind off the remaining sts. the crochet method for Ribbing.

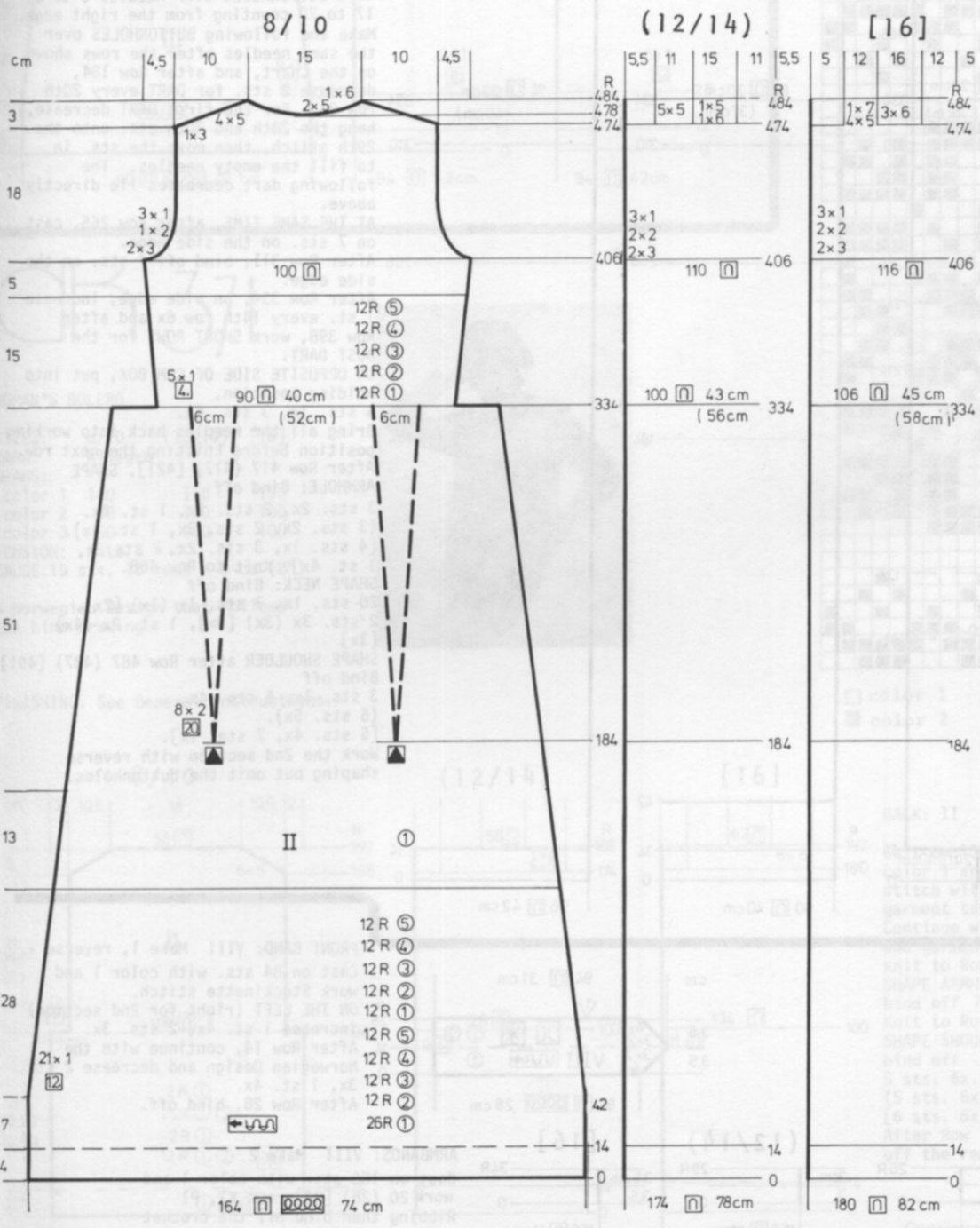

BACK: II

Cast on 164 (174) [180] sts. with color 1 and work Stockinette stitch with color stripes as shown on the Chart, then continue with color 1. After Row 42, ON EACH SIDE, decrease 1 st. every 12th row 21x and AT THE SAME TIME, after Row 184, decrease 2 sts. for EACH DART every 20th row 8x. For the first Dart decrease, hang the 40th and 42nd sts. ON EACH SIDE, onto the 41st st. and move the sts. in to fill the empty needles. The following dart decreases lie directly above.

After Row 334, work the color stripes as shown on the Chart and ON EACH SIDE, increase 1 st. every 4th row 5x. Continue with color 1. After Row 406, SHAPE ARMHOLE: ON EACH SIDE, bind off 3 sts. 2x, 2 sts. 1x, 1 st. 3x. (3 sts. 2x, 2 sts. 2x, 1 st. 3x). [3 sts. 2x, 2 sts. 2x, 1 st. 3x]. Knit to Row 474.

SHAPE SHOULDER: ON EACH SIDE, bind off (watch for Neck Shaping) 3 sts. 1x, 5 sts. 4x. (5 sts. 5x) [5 sts. 4x, 7 sts. 1x]. BUT AT THE SAME TIME, after Row 478, put half the sts. on the left side into holding position and complete the right side first.

*FOR NECK, bind off 5 sts. 2x, 6 sts. 1x. (6 sts. 1x, 5 sts. 1x). [6 sts. 3x]. Move the Cam Box to the left side, turn the Row Counter back to 478 and complete the left half. Follow the instructions from * and don't forget to complete the shoulder shaping.

BELT:

Cast on 20 sts. and work 280 rows K1, P1 Ribbing then bind off the crochet method for Ribbing.



Continued

dk 370

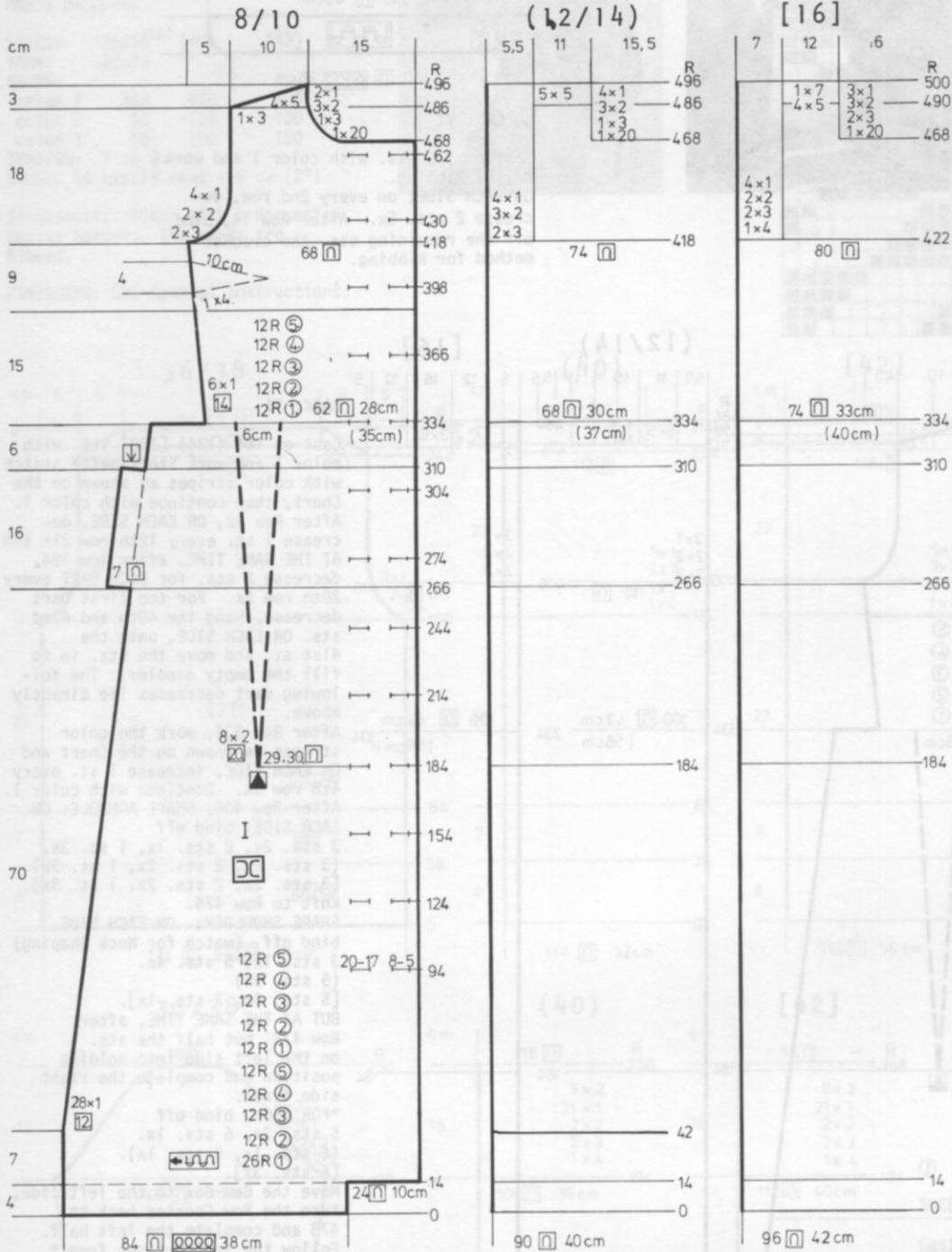

FRONT: I Make 1, reverse 1.

Cast on 84 (90) [96] sts. with color 1 and work Stockinette stitch with color stripes as shown on the Chart.

After Row 14, cast on 24 sts. After Row 42, decrease 1 st. every 12th row 28x and after Row 94, work BUTTONHOLES over needles 5 to 8, 17 to 20 counting from the right edge. Make the following BUTTONHOLES over the same needles after the rows shown on the Chart, and after Row 184, decrease 2 sts. for DART every 20th row 8x. For the first DART decrease, hang the 28th and 30th sts. onto the 29th stitch, then move the sts. in to fill the empty needles. The following dart decreases lie directly above.

AT THE SAME TIME, after Row 265, cast on 7 sts. on the side edge.

After Row 311, bind off 7 sts. on the side edge.

After Row 334, on side edge, increase 1 st. every 14th row 6x and after Row 398, work SHORT ROWS for the BUST DART.

ON OPPOSITE SIDE OF CAM BOX, put into holding position, 4 sts. 1x, 3 sts. 6x.

Bring all the needles back into working position before knitting the next row.

After Row 417 (417) [421], SHAPE ARMHOLE: Bind off

3 sts. 2x, 2 sts. 2x, 1 st. 4x. (3 sts. 2x, 2 sts. 3x, 1 st. 4x).

[4 sts. 1x, 3 sts. 2x, 2 sts. 2x, 1 st. 4x]. Knit to Row 468.

SHAPE NECK: Bind off

20 sts. 1x, 3 sts. 1x (1x) [2x], 2 sts. 3x (3x) [3x], 1 st. 2x (4x) [3x]

SHAPE SHOULDER after Row 487 (487) [491]. Bind off

3 sts. 1x, 5 sts. 4x.

(5 sts. 5x).

[5 sts. 4x, 7 sts. 1x].

Work the 2nd section with reverse shaping but omit the buttonholes.

FRONT BAND: VIII Make 1, reverse 1.

Cast on 84 sts. with color 1 and work Stockinette stitch.

ON THE LEFT (right for 2nd section) increase 1 st. 4x, 2 sts. 3x.

After Row 14, continue with the Norwegian Design and decrease 2 sts. 3x, 1 st. 4x.

After Row 28, bind off.

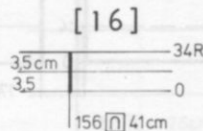
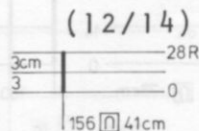
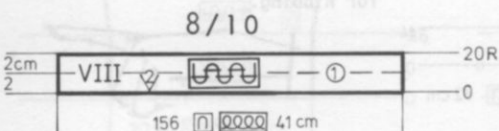
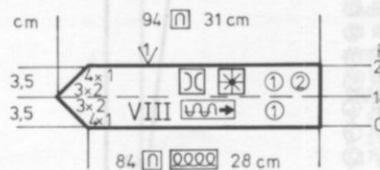

ARMBANDS: VIII Make 2.

Cast on 156 sts. with color 1 and work 20 (28) [34] rows K1, P1

Ribbing then bind off the crochet method for Ribbing.

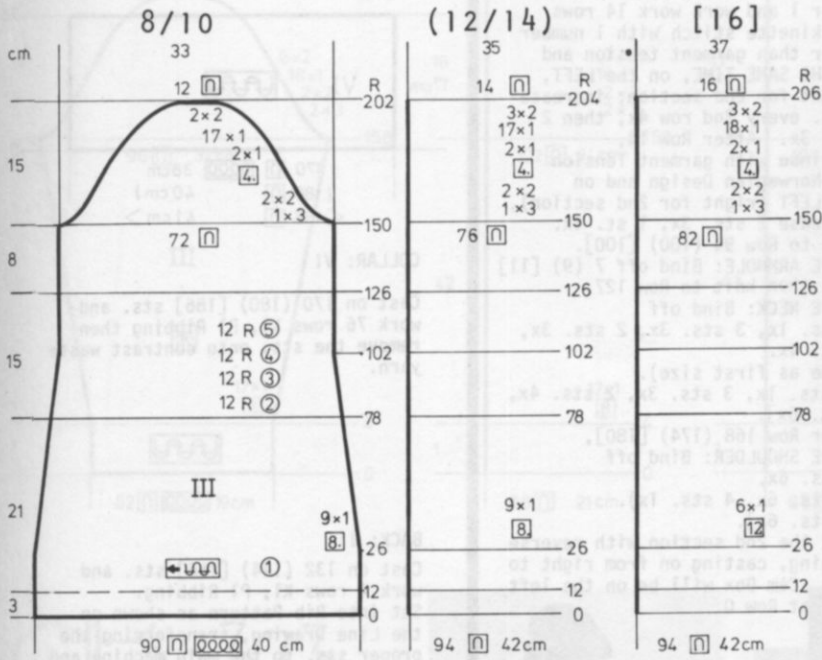

SLEEVES: III

Cast on 90 (94) [94] sts. with color 1 and work Stockinette stitch.
 Knit to Row 26.
 ON EACH SIDE, decrease 1 st. every 8th row 9x.(9x) [every 12th row 6x].
 Knit to Row 78.
 Work the color stripes as shown on the Chart then continue with color 1.
 Knit to Row 150.
 SHAPE CAP: ON EACH SIDE, bind off 3 sts. 1x, 2 sts. 2x, then every 4th row 1 st. 2x, and every 2nd row 1 st. 17x (17x) [18x], 2 sts. 2x (3x) [3x].
 After Row 202 (204) [206], bind off the remaining sts.

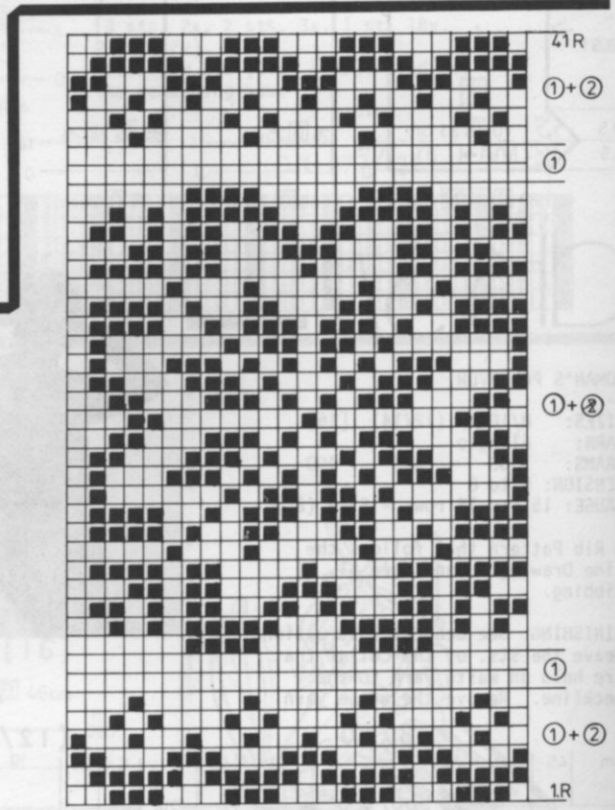

□ color 1
 ■ color 2

dk 371



WOMAN'S BOLERO
 SIZES: 8/10 (12/14) [16]
 YARN: Allegro
 GRAMS:
 color 1 100 150 150
 color 2 50 100 100
 color 3 50 100 100
 TENSION: 6 to 8
 GAUGE: 15 sts. 18 rows = 5 cm (2")

A Norwegian Design that follows the Line Drawing.

FINISHING: See General Instructions.

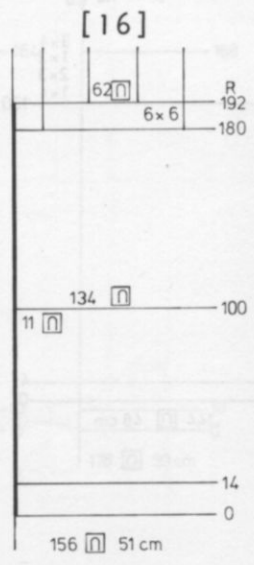
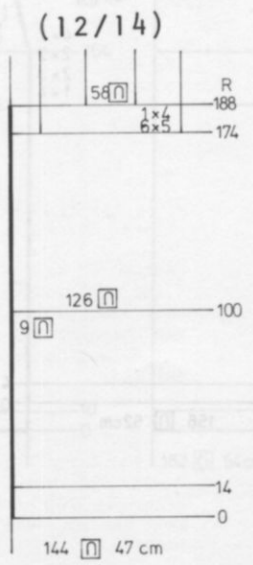
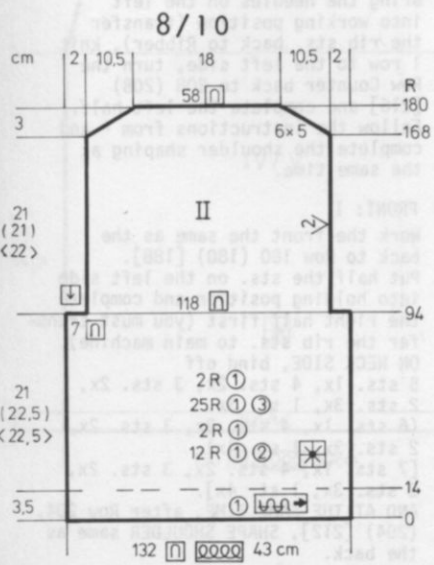

BACK: II

Cast on 132 (144) [156] sts. with color 1 and work 14 rows Stockinette stitch with 1 number lower than garment tension.
 Continue with the Norwegian Design and garment tension.
 Knit to Row 94 (100) [100].
 SHAPE ARMHOLE: ON EACH SIDE, bind off 7 (9) [11] sts.
 Knit to Row 168 (174) [180].
 SHAPE SHOULDER: ON EACH SIDE, bind off 5 sts. 6x.
 (5 sts. 6x, 4 sts. 1x).
 [6 sts. 6x].
 After Row 180 (188) [192], bind off the remaining sts.

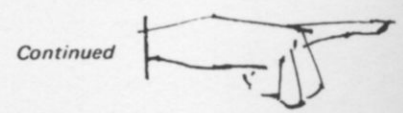

dk 371

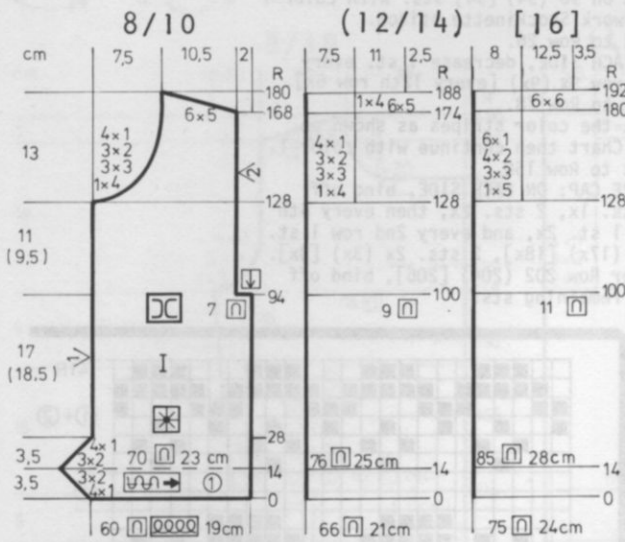

FRONT: I Make 1, reverse 1.

Cast on 60 (66) [75] sts. with color 1 and work work 14 rows Stockinette stitch with 1 number lower than garment tension and AT THE SAME TIME, on the LEFT, (right for 2nd section, increase 1 st. every 2nd row 4x, then 2 sts. 3x. After Row 14, continue with garment Tension and Norwegian Design and on the LEFT (right for 2nd section), decrease 2 sts. 3x, 1 st. 4x. Knit to Row 94 (100) [100].
 SHAPE ARMHOLE: Bind off 7 (9) [11] sts. then knit to Row 127.
 SHAPE NECK: Bind off 4 sts. 1x, 3 sts. 3x, 2 sts. 3x, 1 st. 4x. (same as first size).
 [5 sts. 1x, 3 sts. 3x, 2 sts. 4x, 1 st. 6x].
 After Row 168 (174) [180], SHAPE SHOULDER: Bind off 5 sts. 6x. (5 sts. 6x, 4 sts. 1x). [6 sts. 6x].
 Work the 2nd section with reverse shaping, casting on from right to left. Cam Box will be on the left side at Row 0.

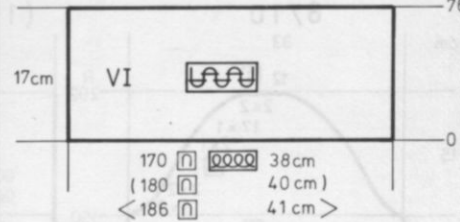

COLLAR: VI

Cast on 170 (180) [186] sts. and work 76 rows K1, P1 Ribbing then remove the sts. onto contrast waste yarn.

dk 372

WOMAN'S PULLOVER

SIZES: 8/10 (12/14) [16]
 YARN: Allegro
 GRAMS: 300 350 400
 TENSION: 6 to 8
 GAUGE: 15 sts. 18 rows = 5 cm (2")

A Rib Pattern that follows the Line Drawing. Bands are K1, P1 Ribbing.

FINISHING: See General Instructions. Weave the sts. of the collar that are held on waste yarn to the neckline. Remove the waste yarn.

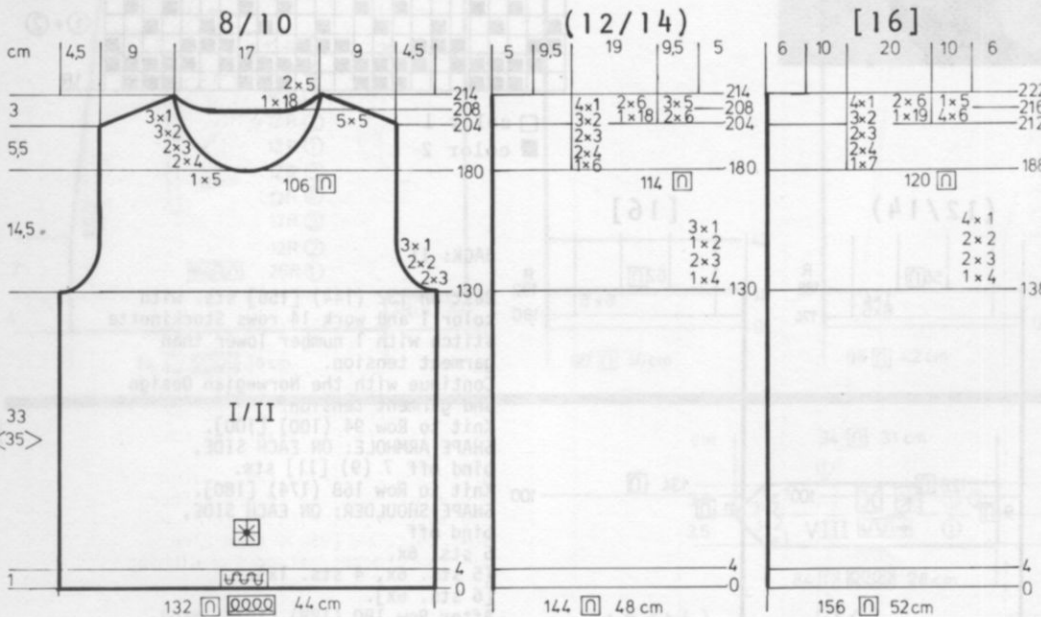

BACK: II

Cast on 132 (144) [156] sts. and work 4 rows K1, P1 Ribbing. Set into Rib Pattern as shown on the Line Drawing, transferring the proper sts. to the main machine and continue in Rib Pattern. Knit 10 rows with 1 tension number lower than garment tension then return the tension to the one you will use.
 Knit to Row 130 (130) [138].
 SHAPE ARMHOLE: ON EACH SIDE, bind off 3 sts. 2x, 2 sts. 2x, 1 st. 3x. (4 sts. 1x, 3 sts. 2x, 2 sts. 1x, 1 st. 3x).
 [4 sts. 1x, 3 sts. 2x, 2 sts. 2x, 1 st. 4x].
 Knit to Row 204 (204) [212].
 SHAPE SHOULDER and after Row 208 (208) [216], SHAPE NECK. FOR SHOULDER, bind off 5 sts. 5x. (6 sts. 2x, 5 sts. 3x). [6 sts. 4x, 5 sts. 1x].
 FOR NECK: After Row 208 (208) [216], put half the sts. on the left into holding position (transfer the rib sts. to main machine first) and *ON NECK SIDE, bind off 18 sts. 1x, 5 sts. 2x. (18 sts. 1x, 6 sts. 2x). [19 sts. 1x, 6 sts. 2x].
 Bring the needles on the left into working position (transfer the rib sts. back to Ribber), knit 1 row to the left side, turn the Row Counter back to 208 (208) [216] and complete the left half. Follow the instructions from * and complete the shoulder shaping at the same time.

FRONT: I

Work the front the same as the back to Row 180 (180) [188]. Put half the sts. on the left side into holding position and complete the right half first (you must transfer the rib sts. to main machine). ON NECK SIDE, bind off 5 sts. 1x, 4 sts. 2x, 3 sts. 2x, 2 sts. 3x, 1 st. 3x. (6 sts. 1x, 4 sts. 2x, 3 sts. 2x, 2 sts. 3x, 1 st. 4x). [7 sts. 1x, 4 sts. 2x, 3 sts. 2x, 2 sts. 3x, 1 st. 4x].
 AND AT THE SAME TIME, after Row 204, (204) [212], SHAPE SHOULDER same as the back.

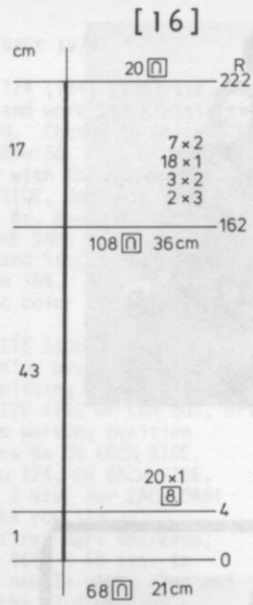
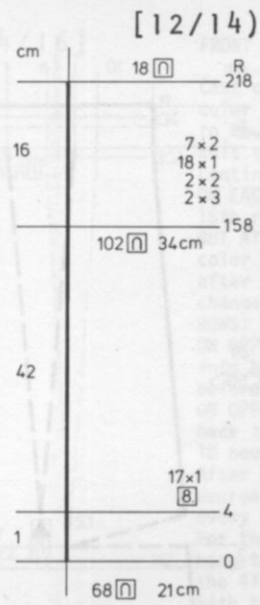
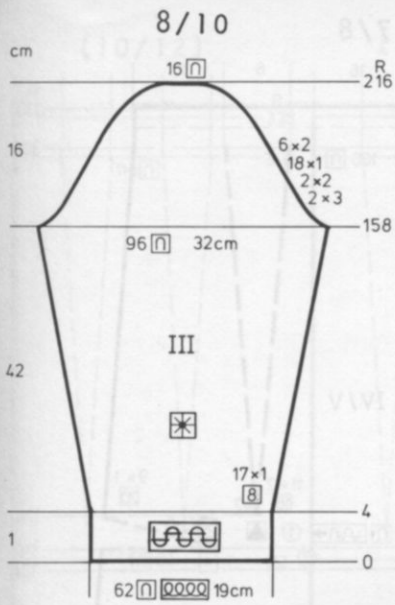

SLEEVES: III

Cast on 62 (68) [68] sts. and work 4 rows K1, P1 Ribbing. Change to Rib Pattern and knit 10 rows with 1 tension number lower. Return to Garment tension and AT THE SAME TIME ON EACH SIDE, on every 8th row, increase 1 st. 17x (17x) [20x]. Knit to Row 158 (158) [162]. SHAPE CAP: ON EACH SIDE, bind off 3 sts. 2x, 2 sts. 2x, 1 st. 18x, 2 sts. 6x: (3 sts. 2x, 2 sts. 2x, 1 st. 18x, 2 sts. 7x). [3 sts. 2x, 2 sts. 3x, 1 st. 18x, 2 sts. 7x]. After Row 216 (218) [222], bind off the remaining sts.

DK 372/ 373

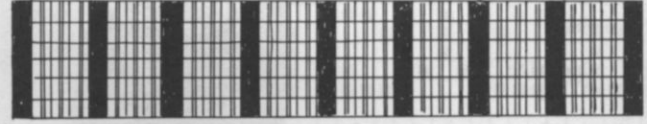

DK 373



WOMAN'S SKIRT

SIZES: 8/10 (12/14) [16]
YARN: Allegro
GRAMS: 250 300 400
TENSION: 6 to 8
GAUGE: 15 sts. 18 rows = 5 cm (2")

A Ribbing Pattern same as DK 372. Follow the Line Drawing.

FINISHING: See General Instructions.

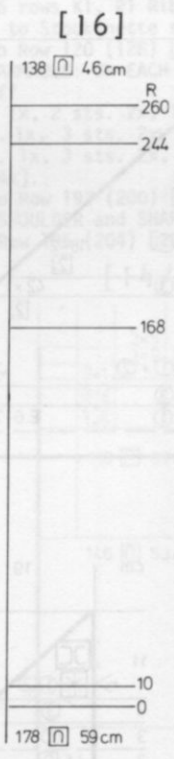
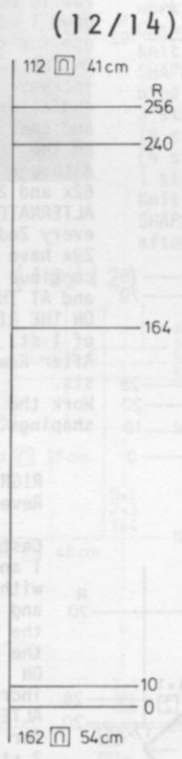
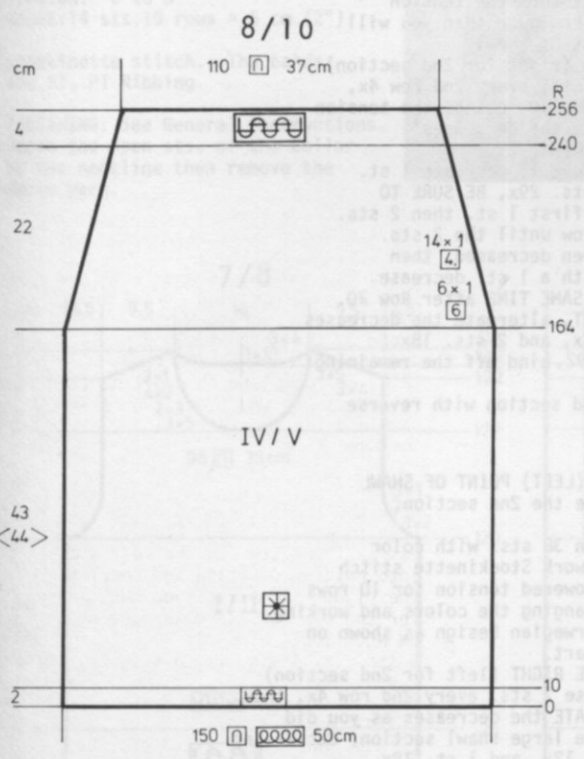

FRONT & BACK IV/V

Cast on 150 (162) [178] sts. and work 10 rows K1, P1 Ribbing. Set the needles into Rib Pattern then knit to Row 164 (164) [168]. ON EACH SIDE, decrease 1 st. every 6th row 6x, every 4th row 14x. After Row 240 (240) [244], Transfer every other stitch to the ribber and work K1, P1 Ribbing to Row 256 (256) [260], then bind off the crochet method for Ribbing.

(10/12)

[14/16]

FRONT & BACK IV/V

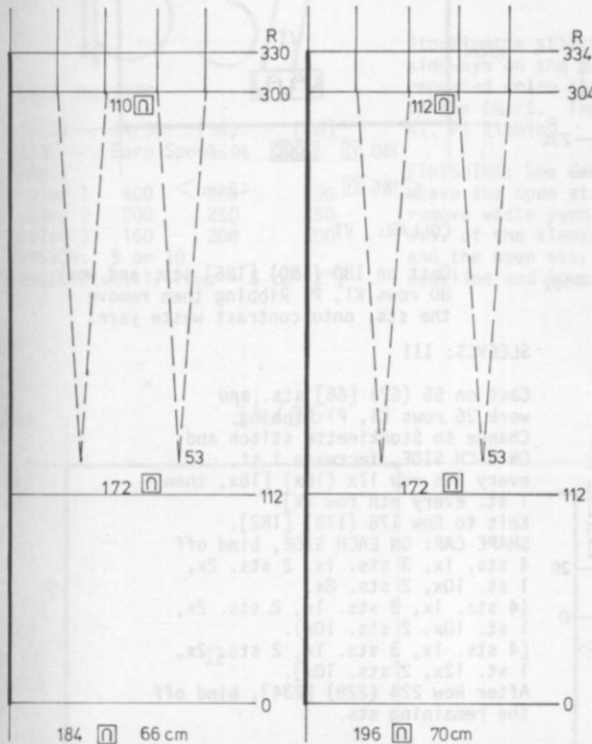

Cast on 174 (184) [196] sts. with color 1 and work Stockinette stitch to Row 50. Change to Color 3 and knit to Row 58. Continue with the Norwegian Design. ON EACH SIDE, decrease 1 st. every 18th row 6x, every 20th row 9x, BUT AT THE SAME TIME, change to color 3 and Stockinette stitch after Row 104. After Row 112, change to color 1 and work SHORT ROWS: ON OPPOSITE SIDE OF CAM BOX, put into holding position 40 sts. before knitting the next 2 rows. ON OPPOSITE SIDE OF CAM BOX, bring back into working position 10 needles 4x ON EACH SIDE. After Row 124, ON EACH SIDE, decrease 2 sts. for EACH DART every 16th row 11x. For the first Dart decrease, hang the 46th & 48 sts. to the 47th needle. (the 52nd and 54th to the 53rd needle) [the 52nd and 54th to the 53rd needle] and Move the sts. in to fill the empty needles. The following dart decreases lie directly above. After Row 300 (300) [304], turn the tension down 1 number and knit to Row 330 (330) [334]. Bind off loosely.

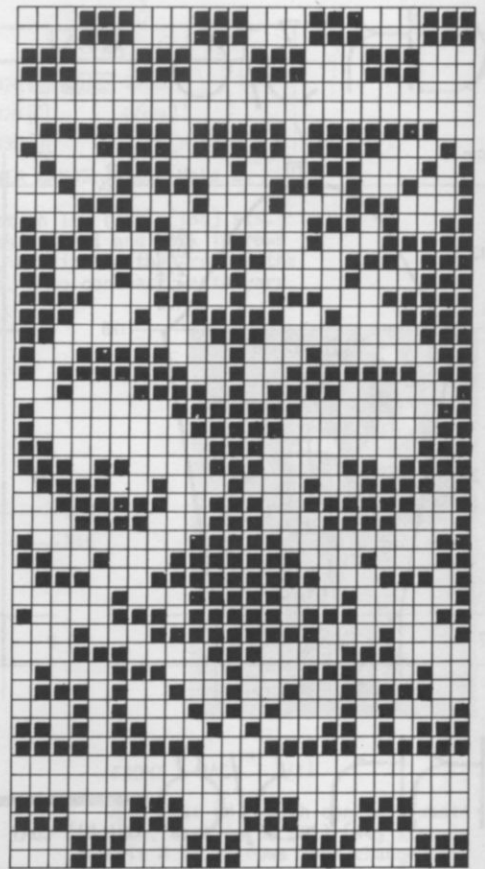

□ Color 1 ■ Color 2

DK 374 & DK 375

DK 376

WOMAN'S PULLOVER

SIZES: 7/8 (10/12) [14/16]
 YARN: Allegro
 GRAMS: 300 350 400
 TENSION: 6 to 8
 GAUGE: 14 sts. 19 rows = 5 cm (2")

Stockinette stitch. The bands are K1, P1 Ribbing.

FINISHING: See General Instructions. Weave the open sts. of the Collar to the neckline then remove the waste yarn.



BACK: II

Cast on 118 (130) [140] sts. and work 26 rows K1, P1 Ribbing. Change to Stockinette stitch and knit to Row 120 (128) [132]. SHAPE ARMHOLE: ON EACH SIDE, bind off 3 sts. 1x, 2 sts. 2x, 1 st. 3x. (4 sts. 1x, 3 sts. 2x, 1 st. 5x). [4 sts. 1x, 3 sts. 2x, 2 sts. 2x, 1 st. 4x]. Knit to Row 192 (200) [204]. SHAPE SHOULDER and SHAPE NECK after Row 196 (204) [208].

FOR SHOULDER, bind off 4 sts. 3x, 5 sts. 3x. (5 sts. 6x). [5 sts. 5x, 6 sts. 1x]. FOR NECK: After Row 196 (204) [208], put half the sts. on the left into holding position and complete the right side first. *Bind off 10 (10) [9] sts. 1x, 4 (4) [5] sts. 3x. Move the Cam Box to the left side, turn the Row Counter back to 196 (204) [208] and complete the left half. Follow the instructions from * and complete the shoulder shaping.

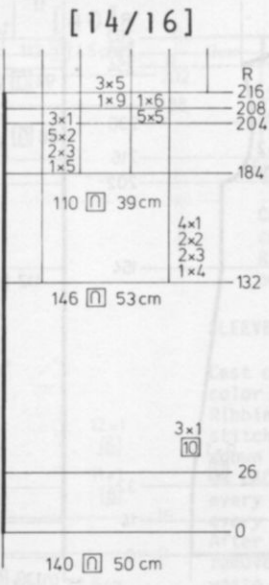
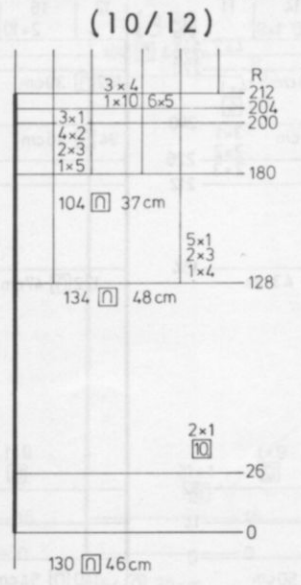
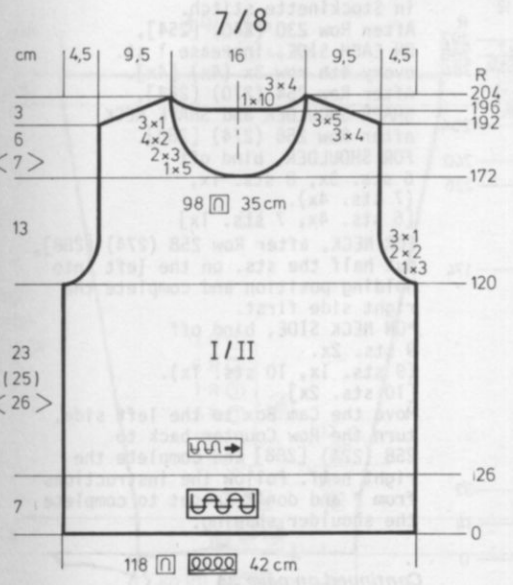

FRONT: I

Work the front the same as the back to Row 172 (180) [184]. Put half the sts. on the left into holding position and complete the right side first. *FOR NECK, bind off 5 sts. 1x, 3 sts. 2x, 2 sts. 4x, 1 st. 3x. (5 sts. 1x, 3 sts. 2x, 2 sts. 4x, 1 st. 3x). [5 sts. 1x, 3 sts. 2x, 2 sts. 5x, 1 st. 3x]. SHAPE SHOULDER same as the back after Row 192 (200) [204]. Move the Cam Box to the left side, turn the Row Counter back to 172 (180) [184] and complete the left half. Follow the instructions from *.



dk 376

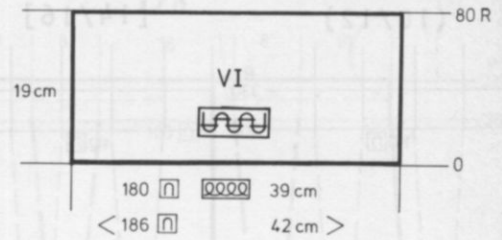
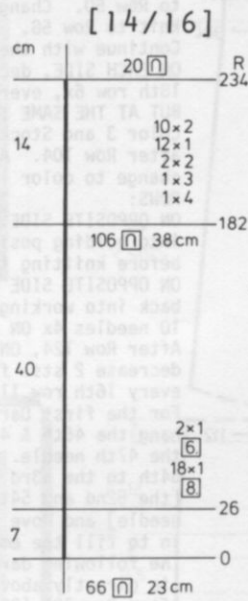
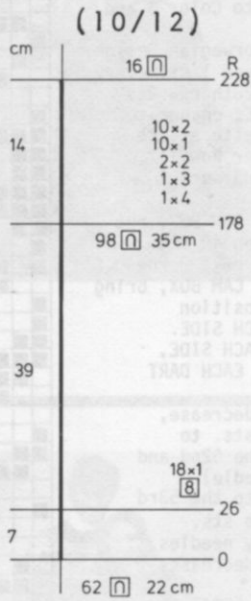
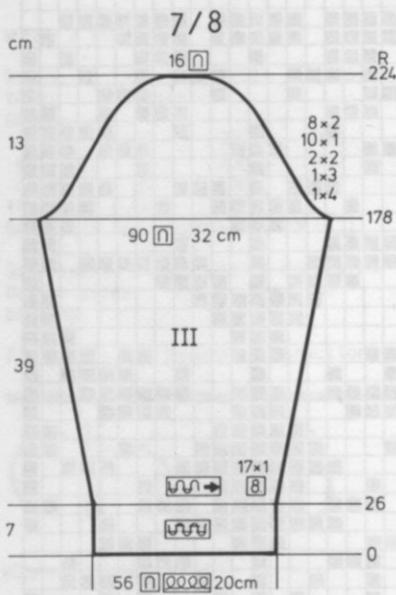

COLLAR: VI

Cast on 180 (180) [186] sts. and work 80 rows K1, P1 Ribbing then remove the sts. onto contrast waste yarn.

SLEEVES: III

Cast on 56 (62) [66] sts. and work 26 rows K1, P1 Ribbing. Change to Stockinette stitch and ON EACH SIDE, increase 1 st. every 8th row 17x (18x) [18x, then 1 st. every 6th row 2x]. Knit to Row 178 (178) [182]. SHAPE CAP: ON EACH SIDE, bind off 4 sts. 1x, 3 sts. 1x, 2 sts. 2x, 1 st. 10x, 2 sts. 8x. (4 sts. 1x, 3 sts. 1x, 2 sts. 2x, 1 st. 10x, 2 sts. 10x). [4 sts. 1x, 3 sts. 1x, 2 sts. 2x, 1 st. 12x, 2 sts. 10x]. After Row 224 (228) [234], bind off the remaining sts.

kk 378

CHILD'S COAT

SIZES: 5/6 (7/8) [9/10]
 YARN: Binia
 GRAMS: 600 700 800
 TENSION: 9 or 10
 GAUGE: 13 sts. 24 rows = 5 cm (2")



A Holding Position Design. KNITTING machine owners use Wheel No. 6. Bands are Stockinette stitch.

FINISHING: Sew the shoulder seams on the right side. Sew all seams. Set in sleeves. Sew shoulders of Yoke together then sew on top of shoulder seams of coat. Slip stitch the yoke to the front and back of coat. For the stand up collar, fold in half then slip stitch to neckline.

Make 3/4" hem at top of pockets then work 1 row single crochet around edges and sew in place. Finish buttonholes and sew on buttons.

PATTERN STITCH: KNITKING machine owners use Wheel No. 6. Push in the right Retractor Button.

*Dial 1, knit 1 row to the left side, knit 1 row back to the right. REPEAT from *

OTHER machines: *Bring every other needle into holding position, knit 1 row to the left. All needles in work, knit 1 row to the right. Repeat from *.



BACK: II

Cast on 120 (130) [140] sts. and work Stockinette stitch with 1 tension lower than garment tension. Knit to Row 14.

Change to garment tension and continue with Holding Position Design. Knit to Row 32.

ON EACH SIDE, decrease 1 st. every 12th row 9x (9x) [every 16th row 9x].

Knit to Row 202 (212) [226]. SHAPE ARMHOLE: ON EACH SIDE, bind off

3 sts. 1x, 2 sts. 3x, 1 st. 2x. (3 sts. 2x, 2 sts. 2x, 1 st. 3x). [same as 2nd size].

After Row 216 (226) [240], lower the tension 1 number and continue in Stockinette stitch.

After Row 230 (240) [254], ON EACH SIDE, increase 1 st. every 4th row 3x (4x) [4x].

After Row 254 (270) [284], SHAPE SHOULDER and SHAPE NECK after Row 258 (274) [288].

FOR SHOULDER, bind off 6 sts. 3x, 8 sts. 1x, (7 sts. 4x).

[6 sts. 4x, 7 sts. 1x] FOR NECK, after Row 258 (274) [288], put half the sts. on the left into holding position and complete the right side first.

*ON NECK SIDE, bind off 9 sts. 2x. (9 sts. 1x, 10 sts. 1x). [10 sts. 2x].

Move the Cam Box to the left side, turn the Row Counter back to 258 (274) [288] and complete the right half. Follow the instructions from * and don't forget to complete the shoulder shaping.

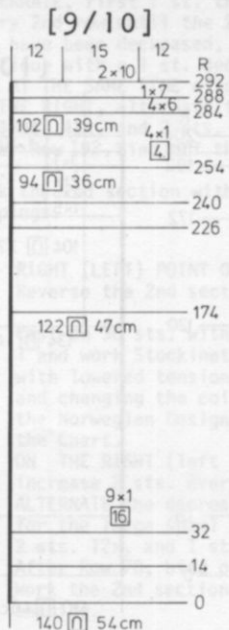
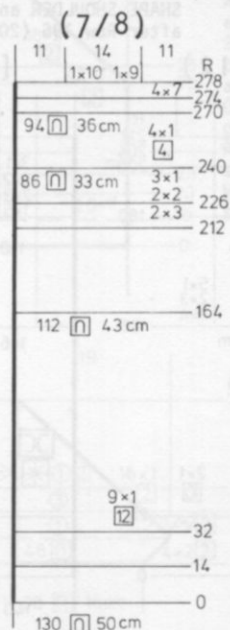
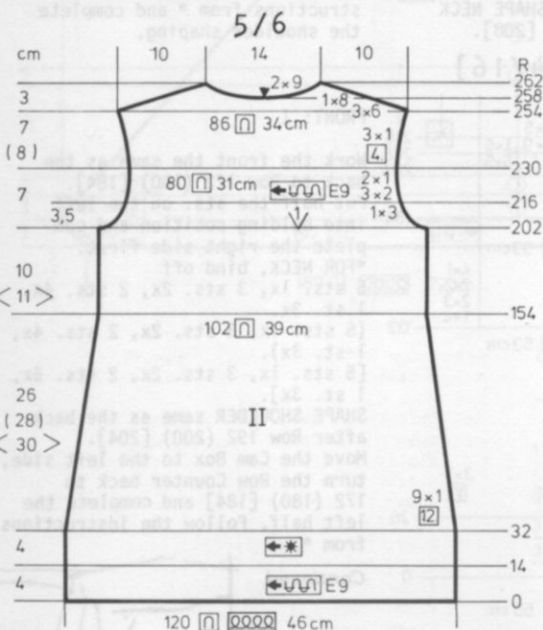

Continued on page 34

np 377

MAN'S PULLOVER

SIZES: 34/36 (38) [40]
YARN: Euro Sport
GRAMS:
 color 1 400 450 500
 color 2 200 250 250
 color 3 150 200 200
TENSION: 9 or 10
GAUGE: 12 sts. 17 rows = 5 cm (2")

Stockinette stitch knitted sideways on the machine with repeated color stripes as shown on the Chart. The bands are K1, P1 Ribbing.

FINISHING: See General Instructions. Weave the open sts. of underarm then remove waste yarn. Weave the open sts. of the sleeves to the armholes and the open sts. of the bands to neckline and lower edge.

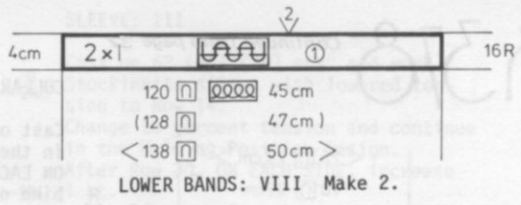

Cast on 120 (128) [138] sts. with color 1 and work 16 rows K1, P1 Ribbing then remove the sts. onto contrast waste yarn.

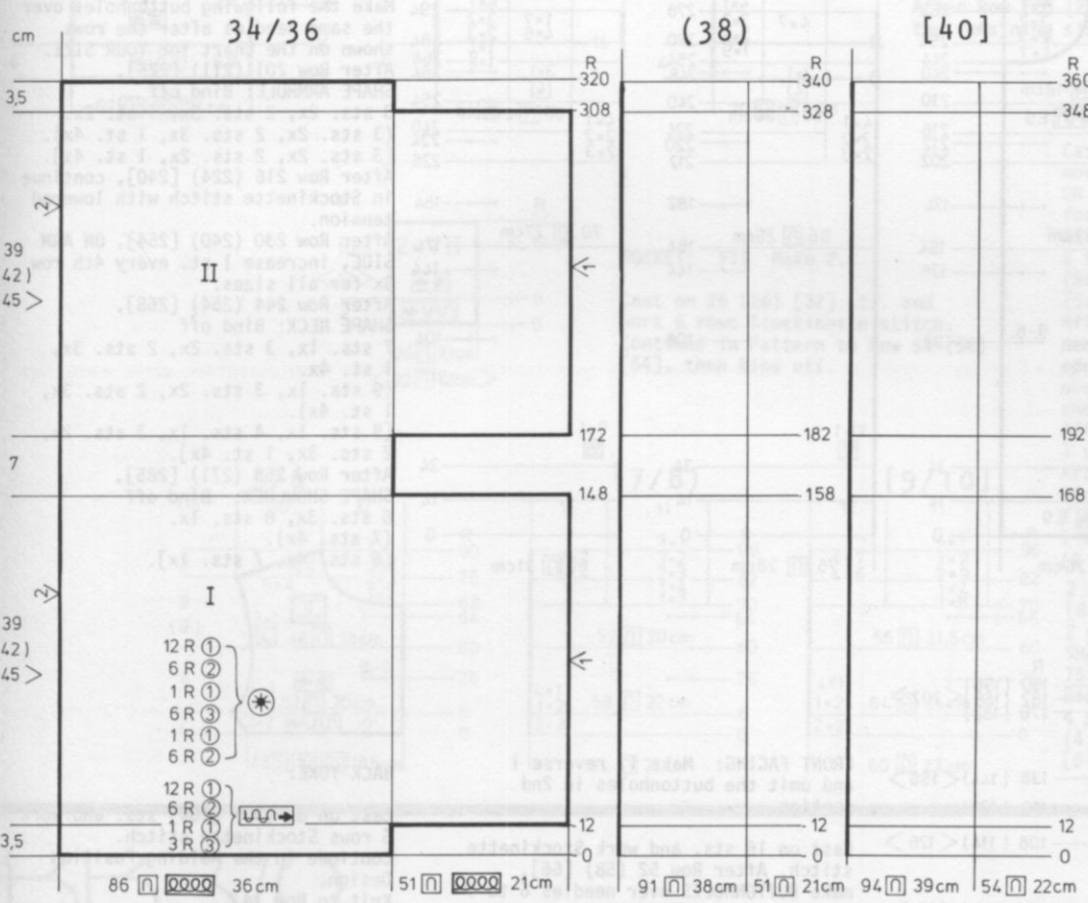

FRONT & BACK I/II

Open Cast on. With contrast waste yarn, cast on 86 (91) [94] sts. Knit 8 to 10 rows then change to garment yarn and color 3. Put Counter at 0.
 Work Stockinette stitch with REPEATED color stripes as shown on the Chart. After Row 12, cast on 51 (51) [54] sts. (you may use waste yarn if you like). Knit to Row 148 (158) [168]. Bind off (or remove on waste yarn) 51 (51) [54] sts.
 Knit to Row 172 (182) [192] over the remaining sts.
 Cast on 51 (51) [54] sts. (or use waste yarn).
 Knit to Row 308 (328) [348]. Bind off (or remove on waste yarn) 51 (51) [54] sts.
 Knit to Row 320 (340) [360], then remove the sts. onto contrast waste yarn.

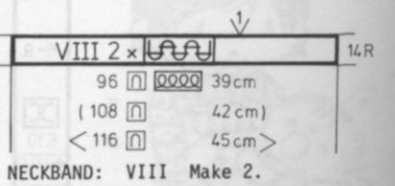
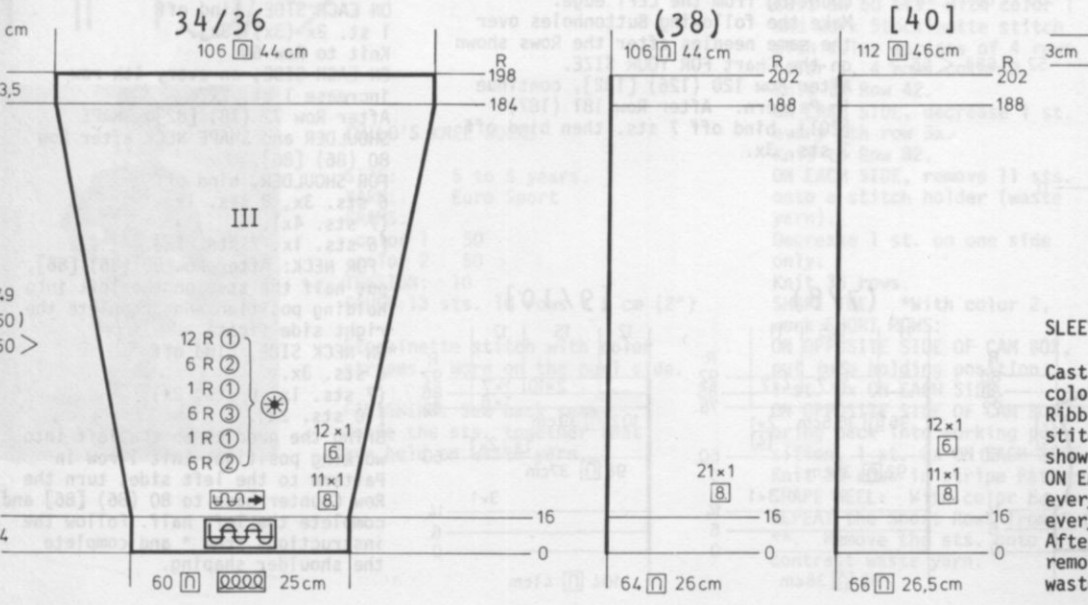

NECKBAND: VIII Make 2.

Cast on 96 (108) [116] sts. with color 1 and work 14 rows K1, P1 Ribbing then remove the sts. onto contrast waste yarn.

SLEEVES: III

Cast on 60 (64) [66] sts. with color 1 and work 16 rows K1, P1 Ribbing. Change to Stockinette stitch with color stripes as shown on the Chart.
 ON EACH SIDE, increase 1 st. every 8th row 11x (21x) [11x], every 6th row 12x (0x) [12x]. After Row 198 (202) [202], remove the sts. onto contrast waste yarn.

COLLAR: VI

Cast on 86 (86) [92] sts. and work in the Holding Position Design. **ON EACH SIDE**, on every 2nd row, bind off 2 sts. 1x, 3 sts. 2x. After Row 14, continue in Stockinette stitch. Cast on 3 sts. 2x, 2 sts. 1x. After Row 28, bind off the remaining stitches.

FRONT: I Make 1, reverse 1 and omit buttonholes in 2nd section.

Cast on 70 (76) [80] sts. and with 1 tension lower than garment tension, knit 14 rows Stockinette stitch. Change to garment tension and continue in the Holding Position Design. Knit to Row 34.

ON SIDE EDGE, decrease 1 st. every 12th row 10x, (every 12th row 10x), [every 16th row 10x], **AND AT THE SAME TIME** after Row 98 (106) [104], make **BUTTONHOLES** over needles 6 to 9 counting from the **RIGHT** edge. Make the following buttonholes over the same needles after the rows shown on the Chart for YOUR SIZE. After Row 201 (211) [225], **SHAPE ARMHOLE: Bind off** 3 sts. 2x, 2 sts. 3x, 1 st. 2x. (3 sts. 2x, 2 sts. 3x, 1 st. 4x), [3 sts. 2x, 2 sts. 2x, 1 st. 4x]. After Row 216 (224) [240], continue in Stockinette stitch with lowered tension. After Row 230 (240) [254], **ON ARM SIDE**, increase 1 st. every 4th row 3x for all sizes. After Row 244 (254) [268], **SHAPE NECK: Bind off** 7 sts. 1x, 3 sts. 2x, 2 sts. 3x, 1 st. 4x. (9 sts. 1x, 3 sts. 2x, 2 sts. 3x, 1 st. 4x). [8 sts. 1x, 4 sts. 1x, 3 sts. 2x, 2 sts. 3x, 1 st. 4x]. After Row 255 (271) [285], **SHAPE SHOULDER: Bind off** 6 sts. 3x, 8 sts. 1x. (7 sts. 4x). [6 sts. 4x, 7 sts. 1x].

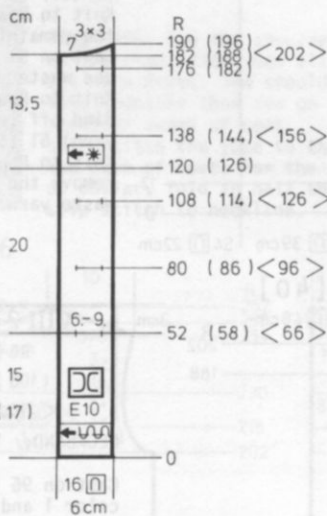
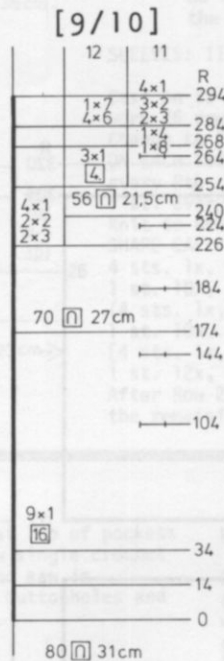
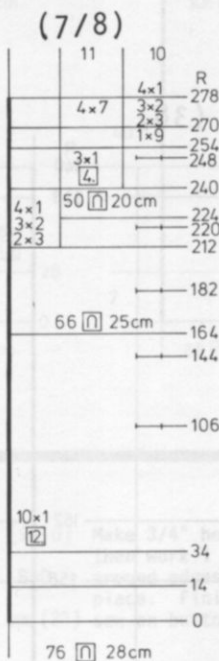
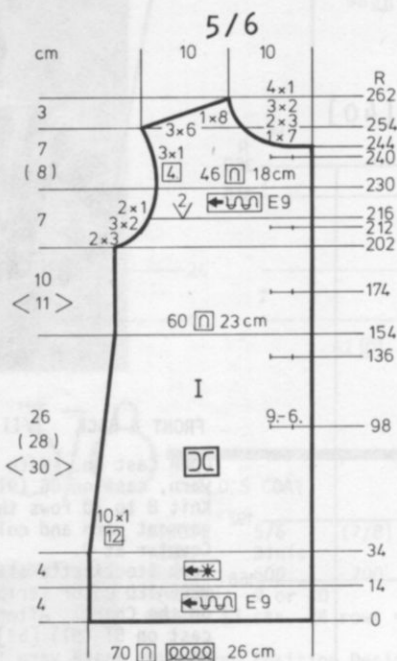
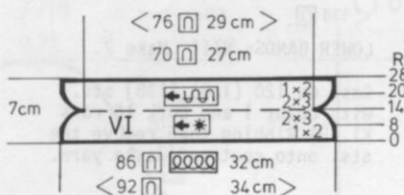

FRONT FACING: Make 1, reverse 1 and omit the buttonholes in 2nd section.

Cast on 16 sts. and work Stockinette stitch. After Row 52 (58) [66], make **BUTTONHOLES** over needles 6 to 9 counting from the **LEFT** edge. Make the following Buttonholes over the same needles after the Rows shown on the Chart **FOR YOUR SIZE**. After Row 120 (126) [132], continue in Pattern. After Row 181 (187) [201], bind off 7 sts. then bind off 3 sts. 3x.

BACK YOKE:

Cast on 88 (98) [104] sts. and work 6 rows Stockinette stitch. Continue in the Holding Position Design. Knit to Row 14.

ON EACH SIDE, bind off 1 st. 2x (3x) [3x]. Knit to Row 60. **ON EACH SIDE**, on every 4th row increase 1 st. 2x. After Row 72 (78) [82], **SHAPE SHOULDER and SHAPE NECK** after Row 80 (86) [86]. **FOR SHOULDER**, bind off 6 sts. 3x, 8 sts. 1x. (7 sts. 4x). [6 sts. 1x, 7 sts. 1x].

FOR NECK: After Row 80 (86) [86], put half the sts. on the left into holding position and complete the right side first.

***ON NECK SIDE**, bind off 6 sts. 3x. (7 sts. 1x, 6 sts. 2x). [10 sts. 2x].

Bring the needles on the left into working position, knit 1 row in Pattern to the left side, turn the Row Counter back to 80 (86) [86] and complete the left half. Follow the instructions from * and complete the shoulder shaping.

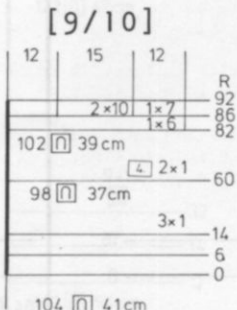
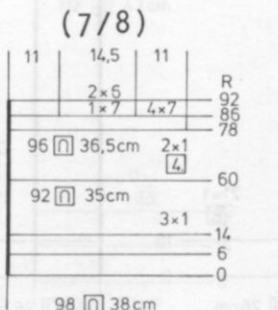
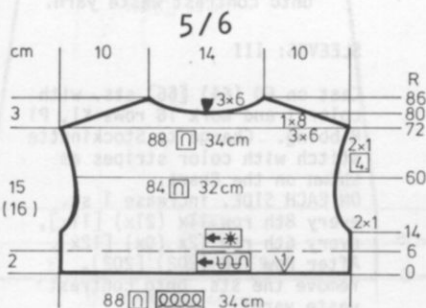

5/6

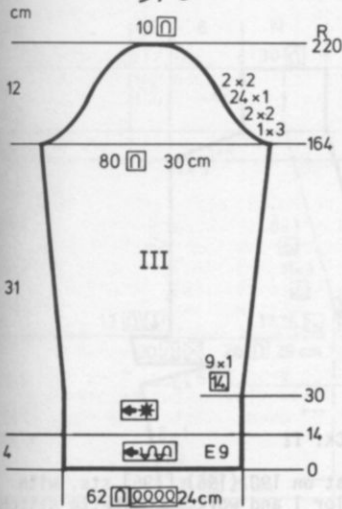

(7/8)

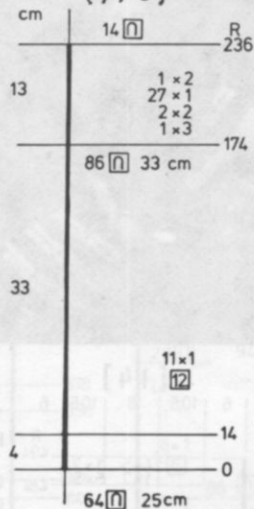

[9/10]

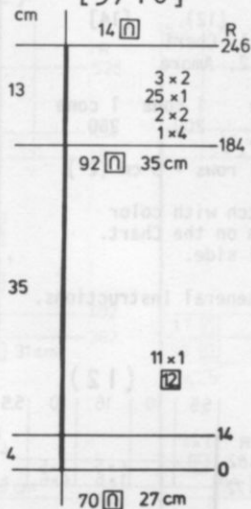

SLEEVE: III

Cast on 62 (64) [70] sts. and work Stockinette stitch with lowered tension to Row 14.
Change to garment tension and continue in the Holding Position Design.
After Row 30, ON EACH SIDE, increase 1 st.
every 14th row 9x.
(every 12th row 11x)
[every 12th row 11x].
Knit to Row 164 (174) [184].
SHAPE CAP: ON EACH SIDE, bind off 3 sts. 1x, 2 sts. 2x, 1 st. 24x, 2 sts. 2x.
(3 sts. 1x, 2 sts. 2x, 1 st. 27x, 2 sts. 1x).
[4 sts. 1x, 2 sts. 2x, 1 st. 25x, 2 sts. 3x].
After Row 220 (236) [246], bind off the remaining sts.

FRONT YOKE: Make 1, reverse 1 and omit the buttonholes in 2nd section.

Cast on 48 (54) [60] sts. and work Stockinette stitch.
ON SIDE EDGE, increase 2 sts. 2x for all sizes.
After Row 6, ON SIDE EDGE, decrease 2 sts. 1x, 1 st. 4x.
(Same as first size).
[Same as first size].
After Row 26, make BUTTONHOLES over needles 6 to 9 counting from the right edge. Make the following Buttonholes over the same needles after the rows shown on the Chart for your size.
After Row 60, ON SIDE EDGE, increase 1 st. every 4th row 3x for all sizes.
After Row 68 (70) [70], SHAPE NECK: Bind off
7 sts. 1x, 3 sts. 2x, 2 sts. 3x, 1 st. 4x.
(7 sts. 1x, 4 sts. 1x, 3 sts. 2x, 2 sts. 3x, 1 st. 3x).
[8 sts. 1x, 4 sts. 1x, 3 sts. 2x, 2 sts. 3x, 1 st. 4x].
SHAPE SHOULDER after Row 75 (81) [81]
Bind off
4 sts. 6x, 5 sts. 1x.
(4 sts. 5x, 3 sts. 2x).
[6 sts. 4x, 7 sts. 1x].

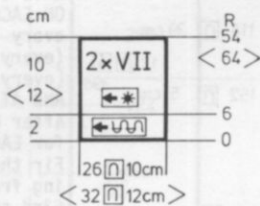

POCKET: VII Make 2.

Cast on 26 (26) [32] sts. and work 6 rows Stockinette stitch.
Continue in Pattern to Row 54 (54) [64], then bind off.

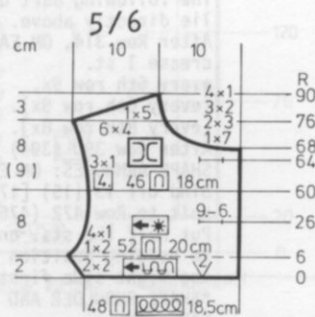

(7/8)

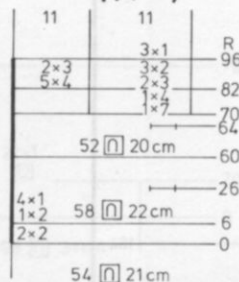

[9/10]

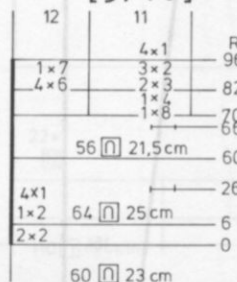

KK 379



CHILD'S KNEE SOCKS

SIZE: 5 to 6 years.
YARN: Euro Sport
GRAMS:
color 1 50
color 2 50
TENSION: 10
GAUGE: 13 sts. 18 rows = 5 cm (2")

Stockinette stitch with color stripes. Worn on the purl side.

FINISHING: Sew back seam.
Weave the sts. together that are held on waste yarn.

Cast on 50 sts. with color 1 and work Stockinette stitch with color stripes of 4 rows color 1, 4 rows color 2.

Knit to Row 42.
ON EACH SIDE, decrease 1 st. every 4th row 3x.

Knit to Row 82.
ON EACH SIDE, remove 11 sts. onto a stitch holder (waste yarn).

Decrease 1 st. on one side only.

Knit 36 rows.
SHAPE TOE: *With color 2, work SHORT ROWS:

ON OPPOSITE SIDE OF CAM BOX, put into holding position 1 st. 6x ON EACH SIDE.

ON OPPOSITE SIDE OF CAM BOX, bring back into working position, 1 st. 6x ON EACH SIDE.**

Knit 36 rows in stripe Pattern.
SHAPE HEEL: With color 2, REPEAT the Short Rows from * to **.

Remove the sts. onto contrast waste yarn.



dk 300

WOMAN'S DRESS

SIZES: 8 (12) [14]

YARN: color 1, Cheri
color 2, Amore

GRAMS:
color 1 1 cone 1 cone 1 cone
color 2 150 200 250
TENSION: 6 or 7
GAUGE: 15 sts. 21 rows = 5 cm (2")

Stockinette stitch with color stripes as shown on the Chart.
Worn on the purl side.

FINISHING: See General Instructions.

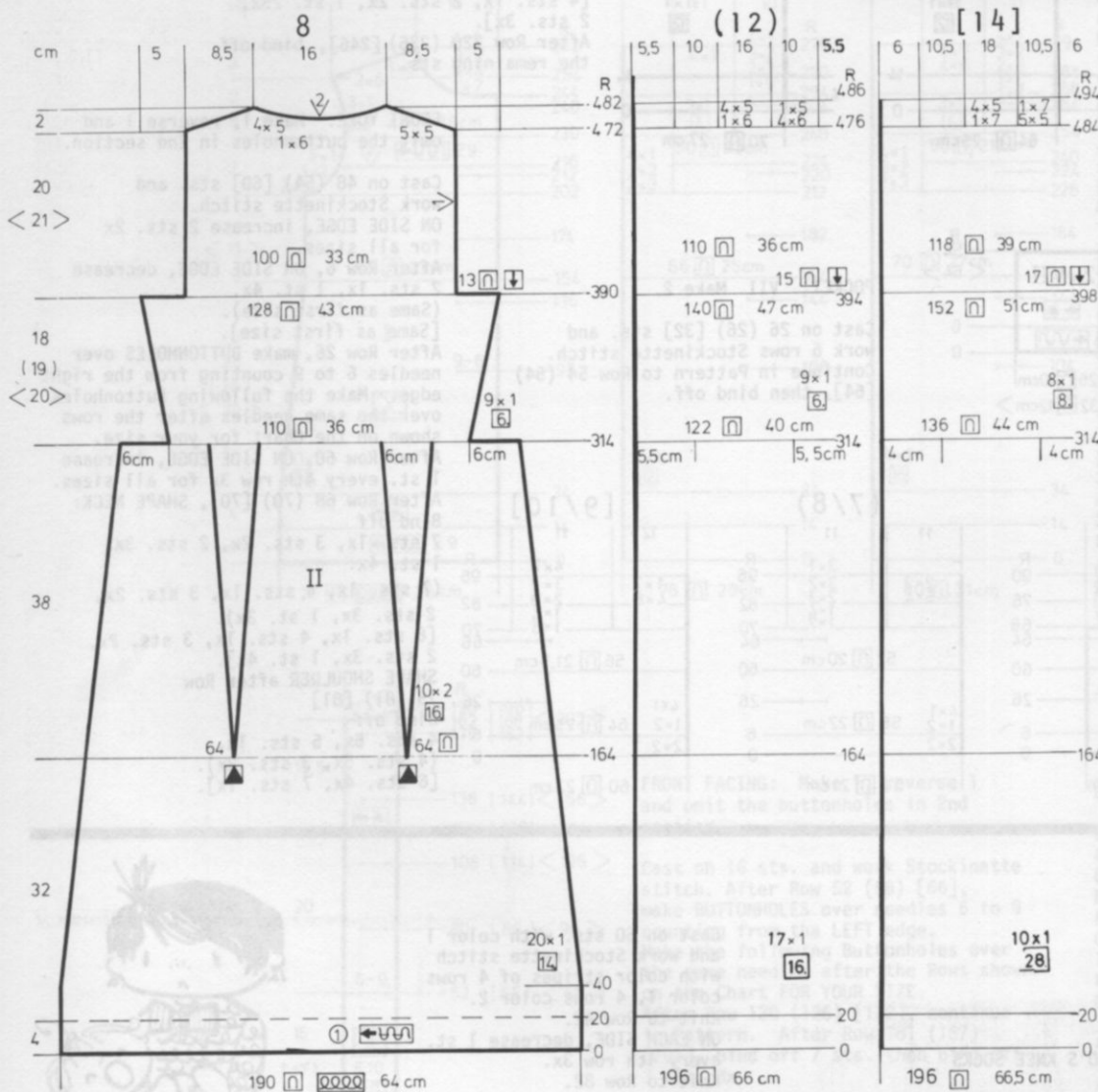

BACK: II

Cast on 190 (196) [196] sts. with color 1 and work Stockinette stitch with color stripes as shown on the Chart for the front section. Knit to Row 40.
ON EACH SIDE, decrease 1 st. every 14th row 20x, (every 16th row 17x), [every 28th row 10x], AND AT THE SAME TIME after Row 164, decrease 2 sts. for EACH DART every 16th row 10x. Fir the first DART DECREASES, counting from each side edge, hang the 63rd sts. on the 64th, the 67th on the 66th and move the sts. in to fill the empty needles. The following dart decreases lie directly above. After Row 314, ON EACH SIDE, increase 1 st. every 6th row 9x. (every 6th row 9x). [every 8th row 8x]. After Row 390 (394) [398], SHAPE ARMHOLES: ON EACH SIDE, bind off 13 (15) [17] sts. Knit to Row 472 (476) [484]. Put half the sts. on the left into holding position and complete the right side first. *SHAPE SHOULDER AND NECK AT THE SAME TIME. FOR SHOULDER, bind off 5 sts. 5x. (6 sts. 4x, 5 sts. 1x). [5 sts. 5x, 7 sts. 1x]. FOR NECK, bind off 6 sts. 1x, 5 sts. 4x. (6 sts. 1x, 5 sts. 4x). [7 sts. 1x, 5 sts. 4x]. Move the Cam Box to the left side, turn the Row Counter back to 472 (476) [484] and complete the left half. Follow the instructions, from *.

SLEEVE: III

Cast on 120 (124) [128] sts. with color 1 and work Stockinette stitch with color stripes as shown on the Chart. Knit to Row 110 (114) [118], then work SHORT ROWS. ON OPPOSITE SIDE OF CAM BOX, put into holding position 6 sts. 8x ON EACH SIDE. (6 sts. 8x ON EACH SIDE). [7 sts. 8x ON EACH SIDE]. Bring all the needles back into working position and bind off loosely.

KK 301

GIRL'S JACKET

SIZES: 7/8 (9/10) [11/12]
YARN: Euro Sport

GRAMS:

color 1	250	300	350
color 2	50	100	100
color 3	50	100	100
color 4	50	100	100

TENSION: 10 on the Ribber side for KNITTING machine.

GAUGE: 11 sts. 14 rows = 5 cm (2")

Stockinette stitch with color stripes as shown on the Chart. Knitted sideways on the machine. Worn on the pur1 side.

FINISHING: See General Instructions.

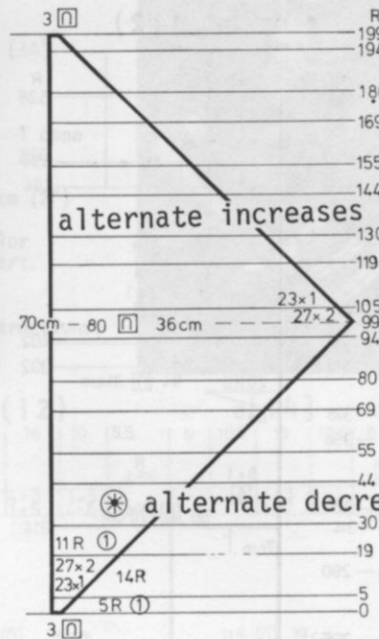

HEAD SCARF:

Cast on 3 sts. with color 1 and work Stockinette stitch with color stripes as shown on the Chart and AT THE SAME TIME, *ON EVERY 2nd row, increase 1 st. 1x, then 2 sts. 1x and REPEAT from * until you have 80 sts. (Row99) then**decrease 2 sts. 1x, 1 st. 1x and REPEAT from ** to Row 199 (3 sts. remain). Bind off.
Work 1 row single crochet around the edges of scarf, then 1 row reverse single crochet.

NECKBAND: VIII

Cast on 84 (84) [90] sts. with color 1 and work 8 rows K1, P1 Ribbing then bind off the crochet method for Ribbing.

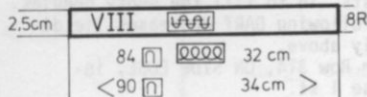

FRONT & BACK: II/I

Because of the different number of rows used for the color stripes for each size, we think it will be easier for you to follow the Chart in the size you need instead of printed instructions which do get complicated when working 3 sizes. You will be knitting a wide stripe in a REPEAT of 4 colors and working 1 row at a time. When knitting the 11 (12) [12] rows of color 1, in order to narrow the lower edge of the Jacket, work SHORT ROWS in each section as follows: Bring 18 needles at the lower edge into holding position, knit 2 rows, bring the needles back into working position and continue the color 1 wide stripe (The short rows are worked only 1 time in each of the color 1 stripes). When you reach the armhole shapings, remove the sts. onto contrast waste yarn, then immediately cast on using the contrast waste yarn. Be sure to return the Row Counter to the correct number and continue.

The STRIPES FOR EACH SIZE are as follows:

SIZE: 7/8
*11 rows color 1
14 rows color stripes (1 row each color). REPEAT from *.

SIZE 9/10
*12 rows color 1
14 rows color stripes (1 row each color). REPEAT from *.

SIZE 11/12
*12 rows color 1
16 rows color stripes (1 row each color). REPEAT from *.

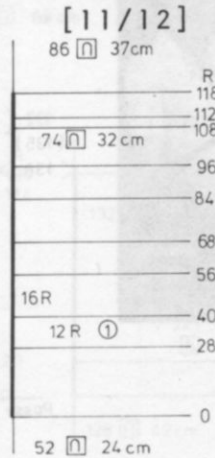
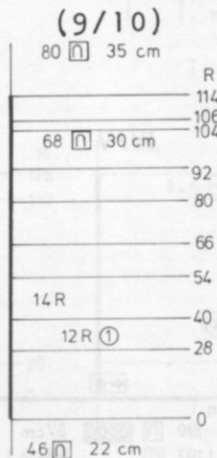
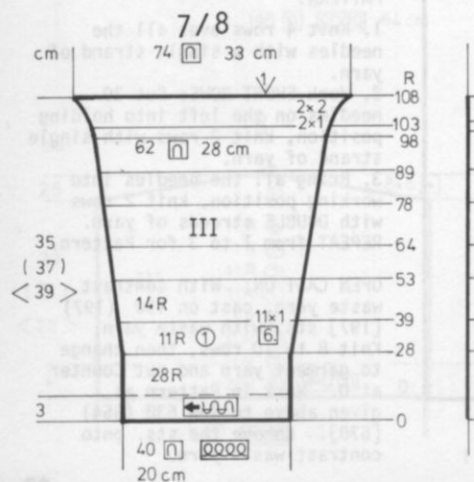
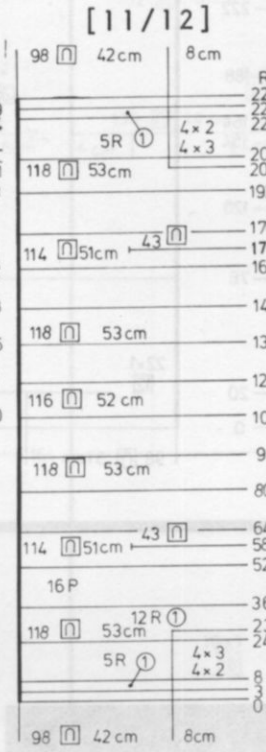
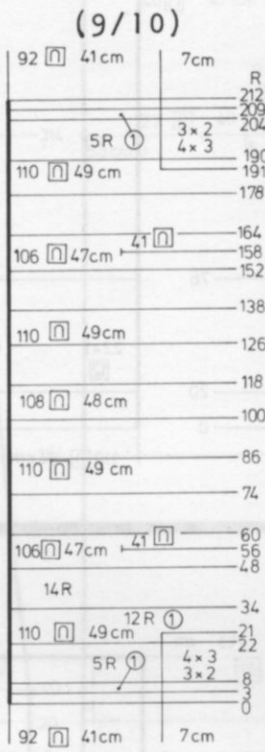
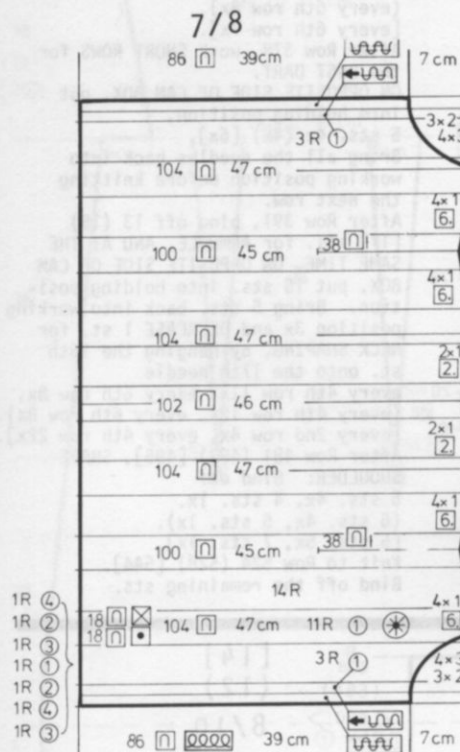

SLEEVE: III

Cast on 40 (46) [52] sts. with color 1 and work Stockinette stitch with color stripes as shown on the Chart for your Size. After Row 28, ON EACH SIDE, increase 1 st. every 6th row 11x.
After Row 103 (106) [112], increase 1 st. every 2nd row 2x, the 2 sts. 2x.
After Row 108 (114) [118], bind off the remaining sts.

dk 382

WOMAN'S LONG SKIRT

SIZES: 7/8 (10/12) [14/16]
 YARN: Summertime
 GRAMS: 700 750 800
 TENSION: 10
 GAUGE: 11 1/2 sts. 24 rows = 5 cm (2")

A Holding Position Design. KNITTING machine owners use Wheel No. 2. Follow the Line Drawing.

FINISHING: See General Instructions.

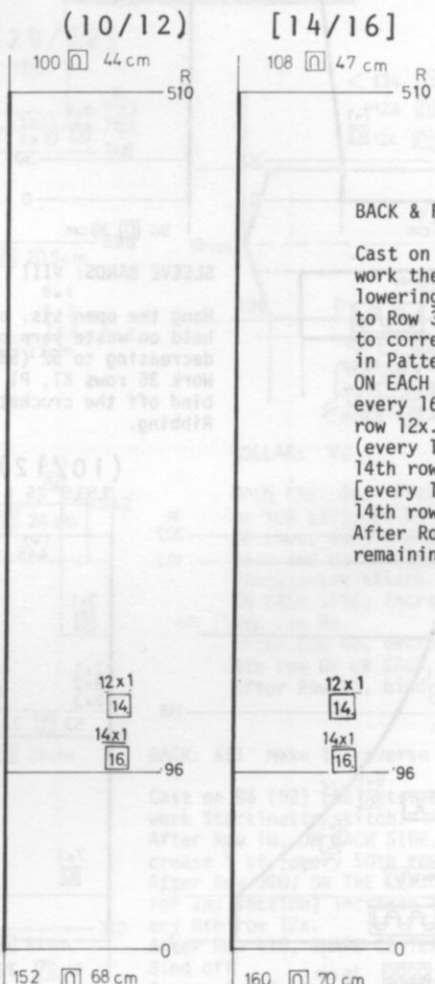
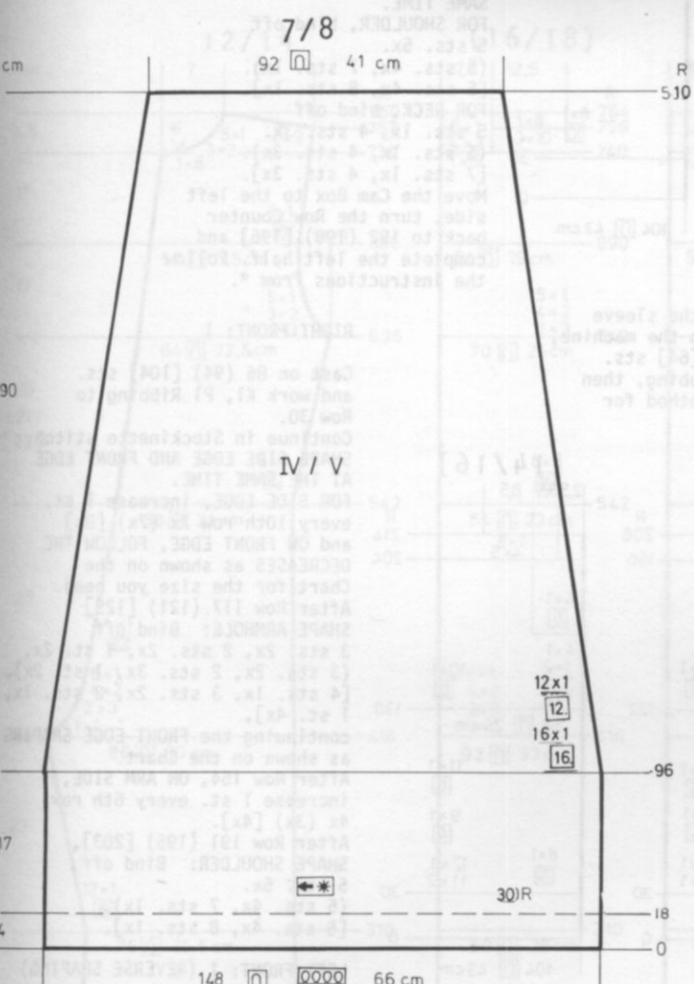
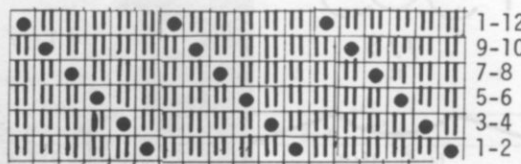

BACK & FRONT: IV/V
 Cast on 148 (152) [160] sts. and work the Holding Position Design lowering the Tension 1 number to Row 30. Turn the Tension to correct number and continue in Pattern to Row 96.
 ON EACH SIDE, decrease 1 st. every 16th row 16x, every 12th row 12x.
 (every 16th row 14x, every 14th row 12x).
 [every 16th row 14x, every 14th row 12x].
 After Row 510, bind off the remaining sts.

dk 383

WOMAN'S BLOUSE

SIZES: 7/8 (10/12) [14/16]
 YARN: Summertime
 GRAMS: 350 400 450
 TENSION: 9 or 10
 GAUGE: 12 sts. 20 rows = 5 cm (2")

Stockinette stitch worn on the purl side.

FINISHING: Sew side and shoulder seams. Weave the open sts. of the left front to the top of band of right front. Sew on front and neck bands after sewing the short ends together.

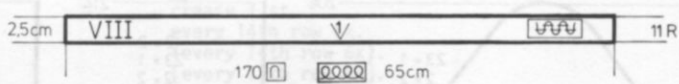

RIGHT FRONT & BACK NECK BAND: VIII

Cast on 170 sts. and work 11 rows K1, P1 Ribbing then bind off the crochet method for Ribbing.

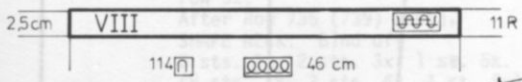

LEFT FRONT BAND: VIII

Cast on 114 sts. and work 11 rows K1, P1 Ribbing then bind off the crochet method for Ribbing.



Continued

dk 383

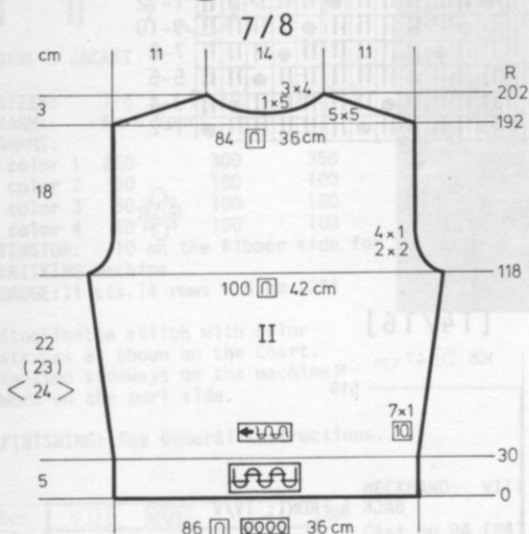

(10/12)

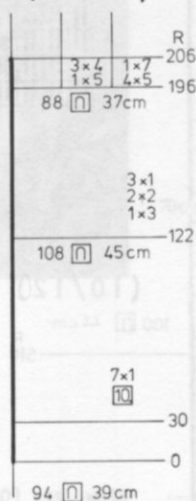

[14/16]

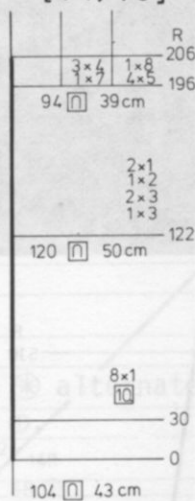

Cast on 86 (94) [104] sts. and work 30 rows K1, P1 Ribbing. Change to Stockinette stitch and ON EACH SIDE, increase 1 st. every 10th row 7x (7x) [8x]. Knit to Row 118, (122) [122]. SHAPE ARMHOLE: ON EACH SIDE, bind off
2 sts. 2x, 1 st. 4x.
(3 sts. 1x, 2 sts. 2x, 1 st. 3x).
[3 sts. 1x, 3 sts. 2x, 2 sts. 1x, 1 st. 2x].
Knit to Row 192 (196) [196]. Put half the stitches on the left into holding position and complete the right side first. *SHAPE SHOULDER AND NECK AT THE SAME TIME.
FOR SHOULDER, bind off
5 sts. 5x.
(5 sts. 4x, 7 sts. 1x).
[5 sts. 4x, 8 sts. 1x].
FOR NECK, bind off
5 sts. 1x, 4 sts. 3x.
(5 sts. 1x, 4 sts. 3x).
[7 sts. 1x, 4 sts. 3x].
Move the Cam Box to the left side, turn the Row Counter back to 192 (196) [196] and complete the left half. Follow the instructions from *.

SLEEVE BANDS: VIII

Hang the open sts. of the sleeve held on waste yarn onto the machine, decreasing to 52 (58) [64] sts. Work 36 rows K1, P1 Ribbing, then bind off the crochet method for Ribbing.

RIGHT FRONT: I

Cast on 86 (94) [104] sts. and work K1, P1 Ribbing to Row 30. Continue in Stockinette stitch. SHAPE SIDE EDGE AND FRONT EDGE AT THE SAME TIME. FOR SIDE EDGE, increase 1 st. every 10th row 7x (7x) [8x] and ON FRONT EDGE, FOLLOW THE DECREASES as shown on the Chart for the size you need. After Row 117, (121) [129] SHAPE ARMHOLE: Bind off
3 sts. 2x, 2 sts. 2x, 1 st. 2x,
(3 sts. 2x, 2 sts. 3x, 1 st. 2x).
[4 sts. 1x, 3 sts. 2x, 2 sts. 1x, 1 st. 4x].
continuing the FRONT EDGE SHAPING as shown on the Chart.
After Row 154, ON ARM SIDE, increase 1 st. every 6th row 4x (3x) [4x].
After Row 191 (195) [203], SHAPE SHOULDER: Bind off
5 sts. 5x.
(5 sts. 4x, 7 sts. 1x).
[5 sts. 4x, 8 sts. 1x].

LEFT FRONT: I (REVERSE SHAPING)

OPEN CAST ON with waste yarn. Knit 8 to 10 rows, change to garment yarn and put Counter at 30, then work the same as RIGHT FRONT (the ribbing is omitted).

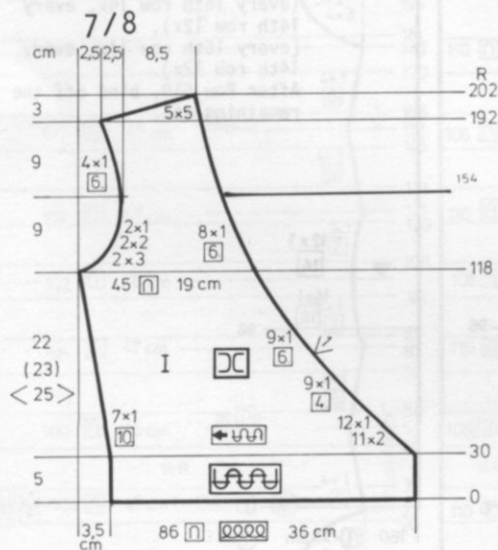

(10/12)

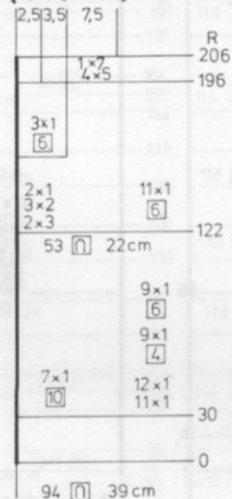

[14/16]

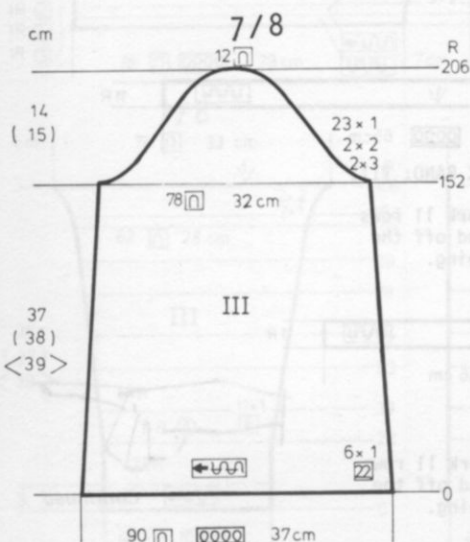
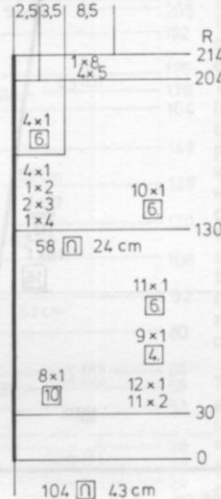

(10/12)

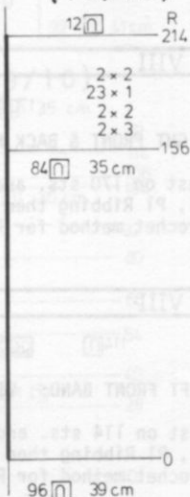

[14/16]

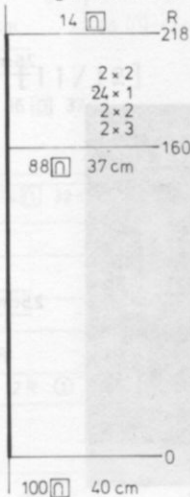

SLEEVES: III

Use OPEN CAST ON with waste yarn. Cast On 90 (96) [100] sts. Knit 8 to 10 rows then change to garment yarn and put Counter at 0. Work Stockinette stitch. ON EACH SIDE, decrease 1 st. every 22nd row 6x. Knit to Row 152 (156) [160]. SHAPE CAP: ON EACH SIDE, bind off
3 sts. 2x, 2 sts. 2x, 1 st. 23x.
(3 sts. 2x, 2 sts. 2x, 1 st. 23x, 2 sts. 2x).
[3 sts. 2x, 2 sts. 2x, 1 st. 24x, 2 sts. 2x].
After Row 206 (214) [218], bind off the remaining sts.

dk 304

WOMAN'S JUMPSUIT

SIZES: 12/14 (16/18) [20/22]
 YARN: Micaela
 GRAMS: 800 850 900
 TENSION: 4 to 6
 GAUGE: 14 sts. 23 rows = 5 cm (2")

Stockinette stitch worn on the purl side.

FINISHING: See General Instructions. Leave 60 cm (23 1/2") open on the front for zipper. Turn under 1 cm (3/8") on front edges and sew to the wrong side, then sew in zipper. Collar, Lapels and flaps: Fold in half then sew in place. Hem pants and sleeve edges. Sew flap to sleeves, turn sleeve up and sew button onto flap. See picture. Sew pockets in place.

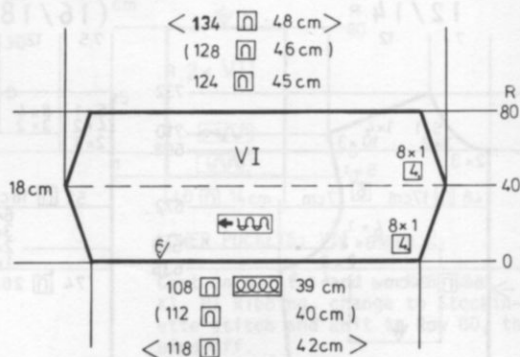
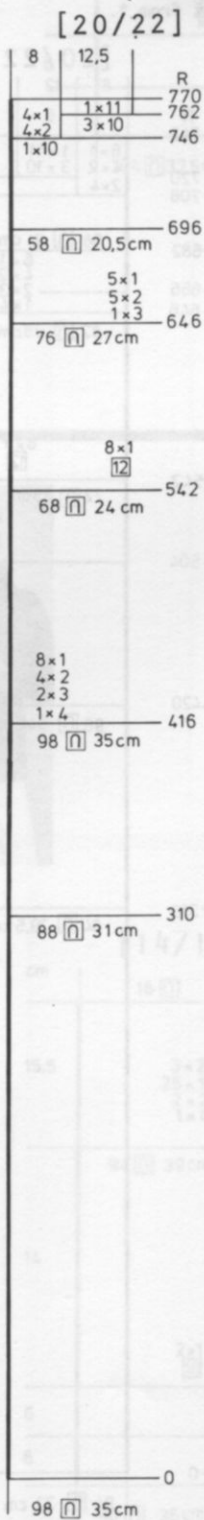
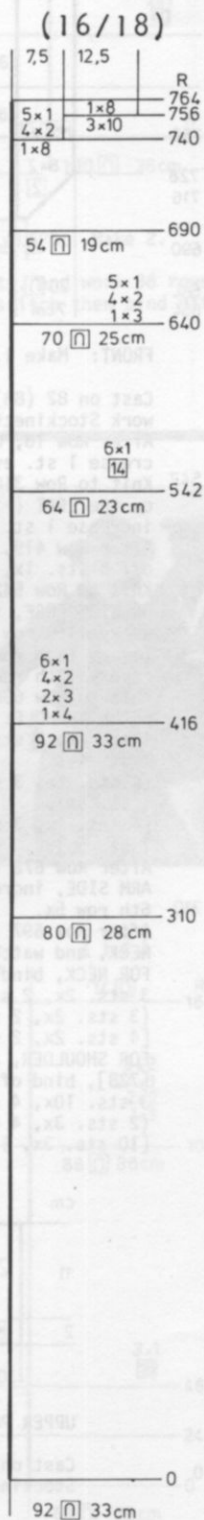
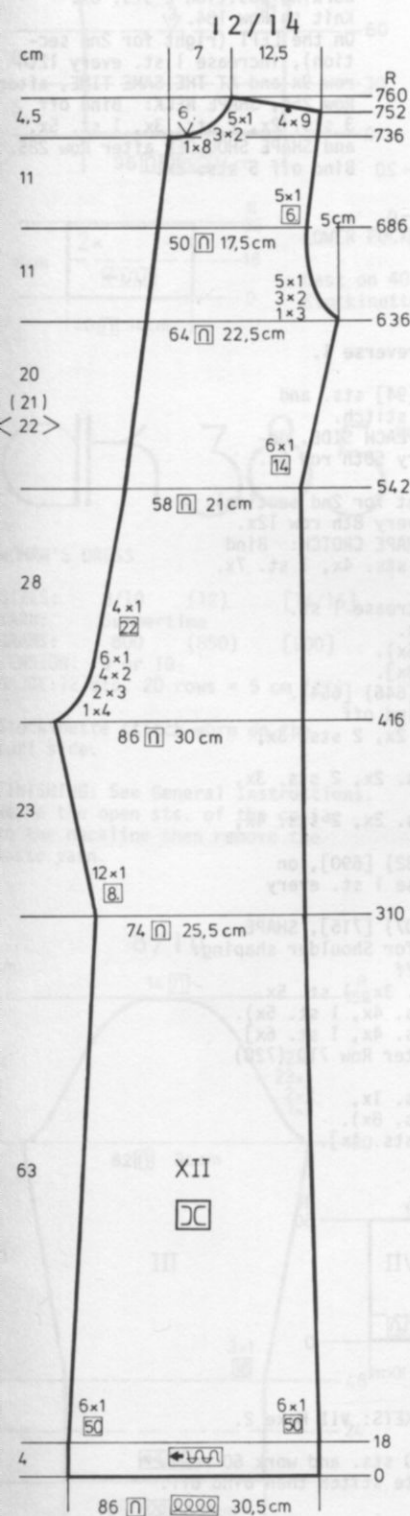

COLLAR: VI

OPEN CAST ON: With waste yarn, cast on 108 (112) [118] sts. Knit 8 to 10 rows, then change to garment yarn and put Counter at 0. Work Stockinette stitch.
 ON EACH SIDE, increase 1 st. every 4th row 8x.
 After Row 40, decrease 1 st. every 4th row 8x ON EACH SIDE.
 After Row 80, bind off.

BACK: XII Make 1, reverse 1.

Cast on 86 (92) [98] sts. and work Stockinette stitch.
 After Row 18, ON EACH SIDE, decrease 1 st. every 50th row 6x.
 After Row 310, ON THE LEFT (right for 2nd section) increase 1 st. every 8th row 12x.
 After Row 415, SHAPE CENTER BACK: Bind off
 4 sts. 1x, 3 sts. 2x, 2 sts. 4x, 1 st. 6x (6x) [8x], then decrease 1 st. every 22nd row 4x.
 After Row 542, ON SIDE EDGE, increase 1 st. every 14th row 6x.
 (every 14th row 6x).
 [every 12th row 8x].
 After Row 636 (640) [646], SHAPE ARMHOLE: Bind off
 3 sts. 1x, 2 sts. 3x, 1 st. 5x. (3 sts. 1x, 2 sts. 4x, 1 st. 5x).
 [3 sts. 1x, 2 sts. 5x, 1 st. 5x].
 After Row 686 (690) [696] ON ARM SIDE, increase 1 st. every 6th row 5x.
 After Row 735 (739) [745], SHAPE NECK: Bind off
 8 sts. 1x, 2 sts. 3x, 1 st. 5x. (8 sts. 1x, 2 sts. 4x, 1 st. 5x).
 [10 sts. 1x, 2 sts. 4x, 1 st. 4x].
 After Row 752 (756) [762], SHAPE SHOULDER: Bind off
 9 sts. 4x.
 (10 sts. 3x, 8 sts. 1x).
 [10 sts. 3x, 11 sts. 1x].



Continua

dk 384

SLEEVE TABS: Make 2.

Cast on 28 sts. and work Stockinette stitch.

After Row 56, make **BUTTONHOLES ON EACH SIDE**, over needles 6 to 9, counting from each edge.

After Row 60, put half the sts. on the left into holding position and complete the right side first.

*ON EACH SIDE, decrease 1 st. every 2nd row 7x.

Move the Cam Box to the left side, turn the Row Counter back to 60 and complete the left half.

Follow the instructions from *.

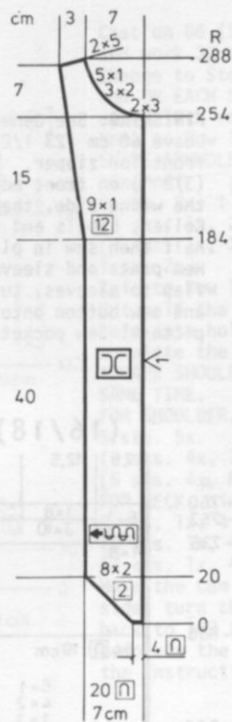
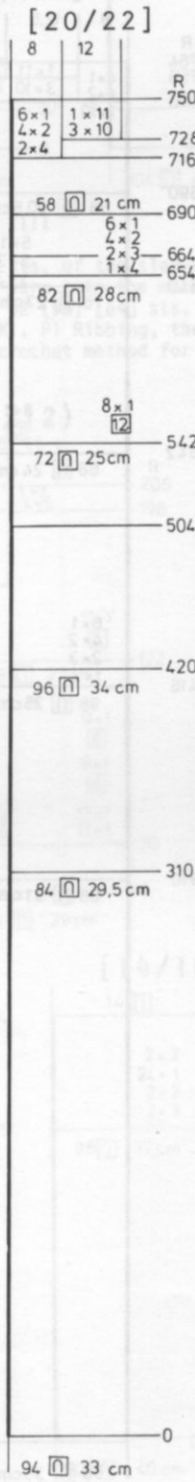
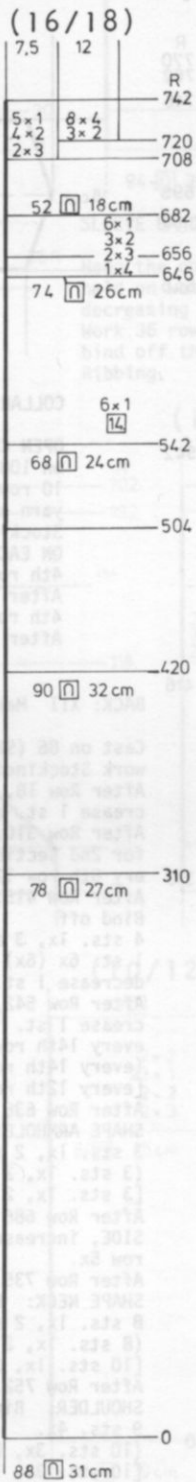
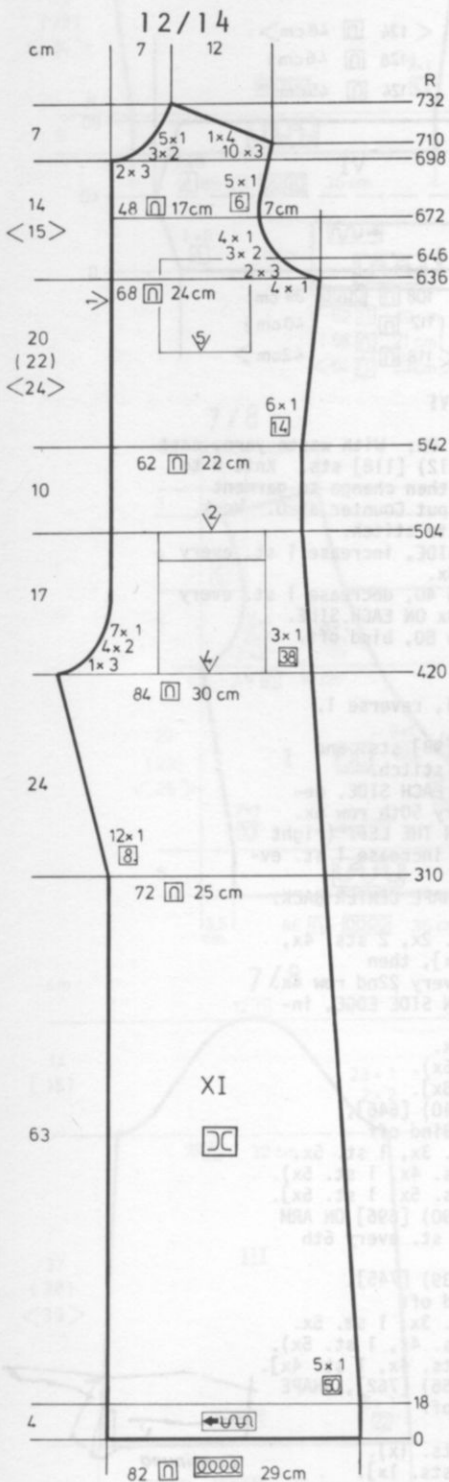
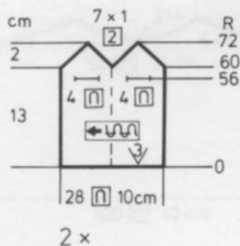

FRONT FACING: Make 1, reverse 1.

Cast on 20 sts. and work Stockinette stitch.

Put 16 sts. on the LEFT (right for 2nd section) into holding position. On every 2nd row, bring back into working position 2 sts. 8x. Knit to Row 184.

On the LEFT (right for 2nd section), increase 1 st. every 12th row 9x and AT THE SAME TIME, after Row 254, **SHAPE NECK**: Bind off 3 sts. 2x, 2 sts. 3x, 1 st. 5x, and **SHAPE SHOULDER** after Row 285. Bind off 5 sts. 2x.

FRONT: Make 1, reverse 1.

Cast on 82 (88) [94] sts. and work Stockinette stitch.

After Row 18, ON EACH SIDE, decrease 1 st. every 50th row 5x. Knit to Row 310.

on the LEFT (right for 2nd section), increase 1 st. every 8th row 12x. After Row 419, **SHAPE CROTCH**: Bind off 3 sts. 1x, 2 sts. 4x, 1 st. 7x. Knit to Row 542.

ON SIDE EDGE, increase 1 st. every 14th row 6x. (every 14th row 6x). [every 12th row 8x].

Knit to Row 636 (646) [654].

SHAPE ARMHOLE: Bind off 1 st. 4x, 3 sts. 2x, 2 sts. 3x, 1 st. 4x. (4 sts. 1x, 3 sts. 2x, 2 sts. 3x, 1 st. 6x). [4 sts. 1x, 3 sts. 2x, 2 sts. 4x, 1 st. 6x].

After Row 672 (682) [690], on ARM SIDE, increase 1 st. every 6th row 5x.

After Row 697 (707) [715], **SHAPE NECK**, and watch for Shoulder shaping:

FOR NECK, bind off 3 sts. 2x, 2 sts. 3x, 1 st. 5x. (3 sts. 2x, 2 sts. 4x, 1 st. 5x). [4 sts. 2x, 2 sts. 4x, 1 st. 6x]. **FOR SHOULDER**, after Row 710 (720) [728], bind off 3 sts. 10x, 4 sts. 1x, (2 sts. 3x, 4 sts. 8x). [10 sts. 3x, 11 sts. 1x].

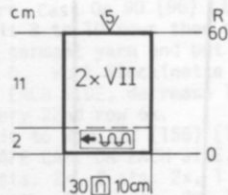

UPPER POCKETS: VII Make 2.

Cast on 30 sts. and work 60 rows Stockinette stitch then bind off.

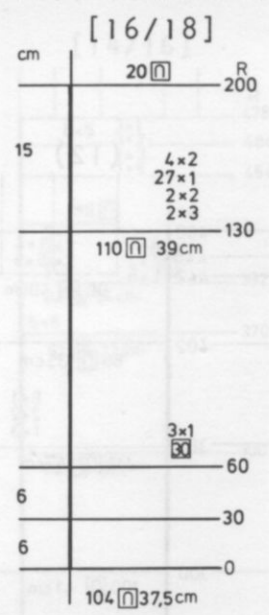
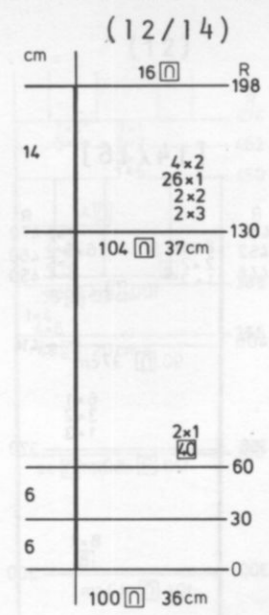
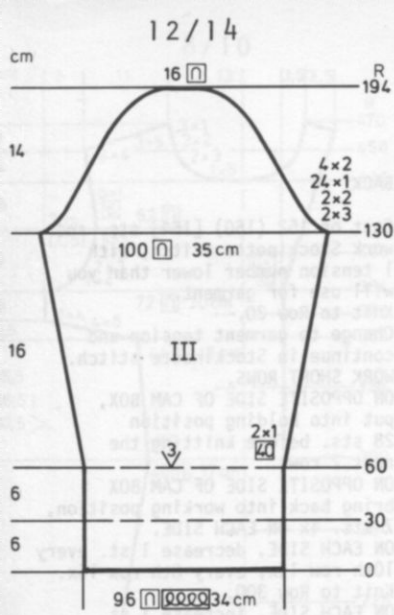

SLEEVES: III
 Cast on 96 (100) [104] sts. and work Stockinette stitch.
 Knit to Row 60.
 ON EACH SIDE, increase 1 st. every 40th row 2x.
 (every 40th row 2x).
 [every 30th row 3x].
 Knit to Row 130.
 SHAPE CAP: ON EACH SIDE, bind off 3 sts. 2x, 2sts. 2x, 1 st. 24x, 2 sts. 4x.
 (3 sts. 2x, 2 sts. 2x, 1 st. 26x, 2 sts. 4x).
 [3 sts. 2x, 2 sts. 2x, 1 st. 27x, 2 sts. 4x].
 After Row 194 (198) [200], bind off the remaining sts.

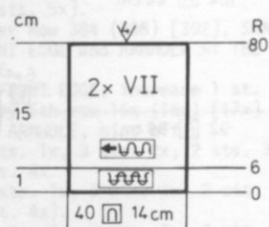

LOWER POCKETS: VII Make 2.

Cast on 40 sts. and work 6 rows K1, P1 Ribbing, change to Stockinette stitch and knit to Row 80, then bind off.

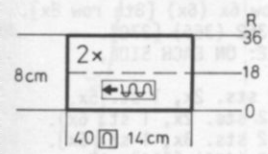

LOWER POCKET FLAPS: Make 2.
 Cast on 40 sts. and work 36 rows Stockinette stitch then bind off.

dk 385

WOMAN'S DRESS
 SIZES: 8/10 (12) [14/16]
 YARN: Summertime
 GRAMS: 800 (850) [900]
 TENSION: 9 or 10
 GAUGE: 12 sts. 20 rows = 5 cm (2")

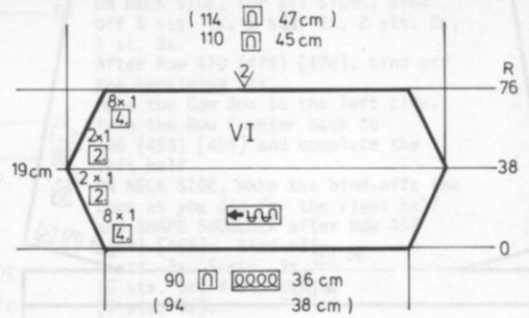

COLLAR: VI

OPEN CAST ON. With waste yarn, cast on 90 (94) [94] sts. and work Stockinette stitch.
 ON EACH SIDE, on every 4th row, increase 1 st. 8x, then every 2nd row 1 st. 2x.
 After Row 38, ON EACH SIDE, decrease 1 st. every 2nd row 2x, then every 4th row 8x.
 After Row 76, remove the sts. onto contrast waste yarn.

Stockinette stitch worn on the purl side.
 FINISHING: See General Instructions. Weave the open sts. of the collar to the neckline then remove the waste yarn.

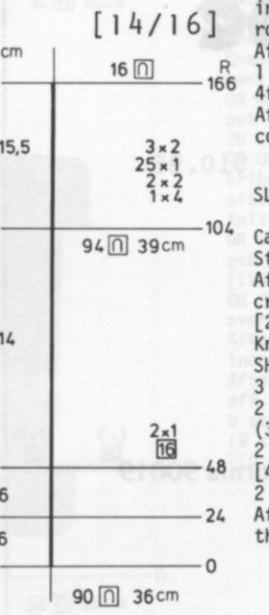
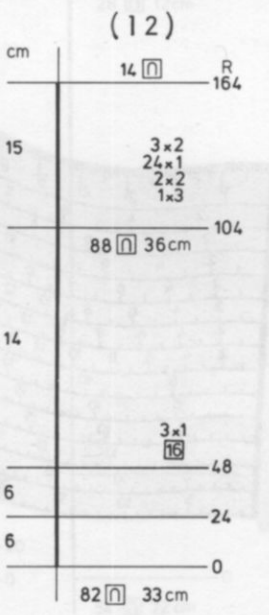
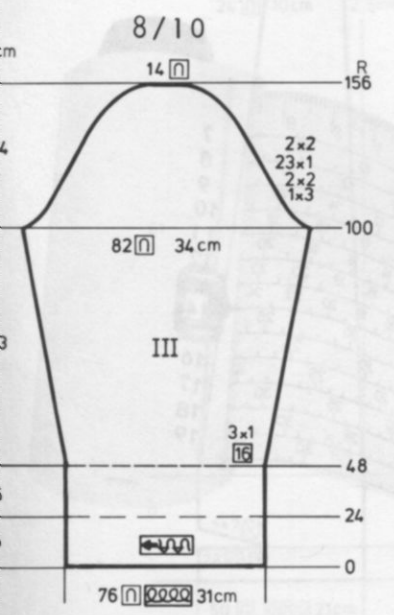

SLEEVES: III

Cast on 76 (82) [90] sts. and work Stockinette stitch.
 After Row 48, ON EACH SIDE, increase 1 st. every 16th row 3x (3x) [2x].
 Knit to Row 100 (104) [104].
 SHAPE CAP: ON EACH SIDE, bind off 3 sts. 1x, 2 sts. 2x, 1 st. 23x, 2 sts. 2x.
 (3 sts. 1x, 2 sts. 2x, 1 st. 24x, 2 sts. 3x).
 [4 sts. 1x, 2 sts. 2x, 1 st. 25x, 2 sts. 3x].
 After Row 156 (164) [166], bind off the remaining sts.

Continued



dk 385

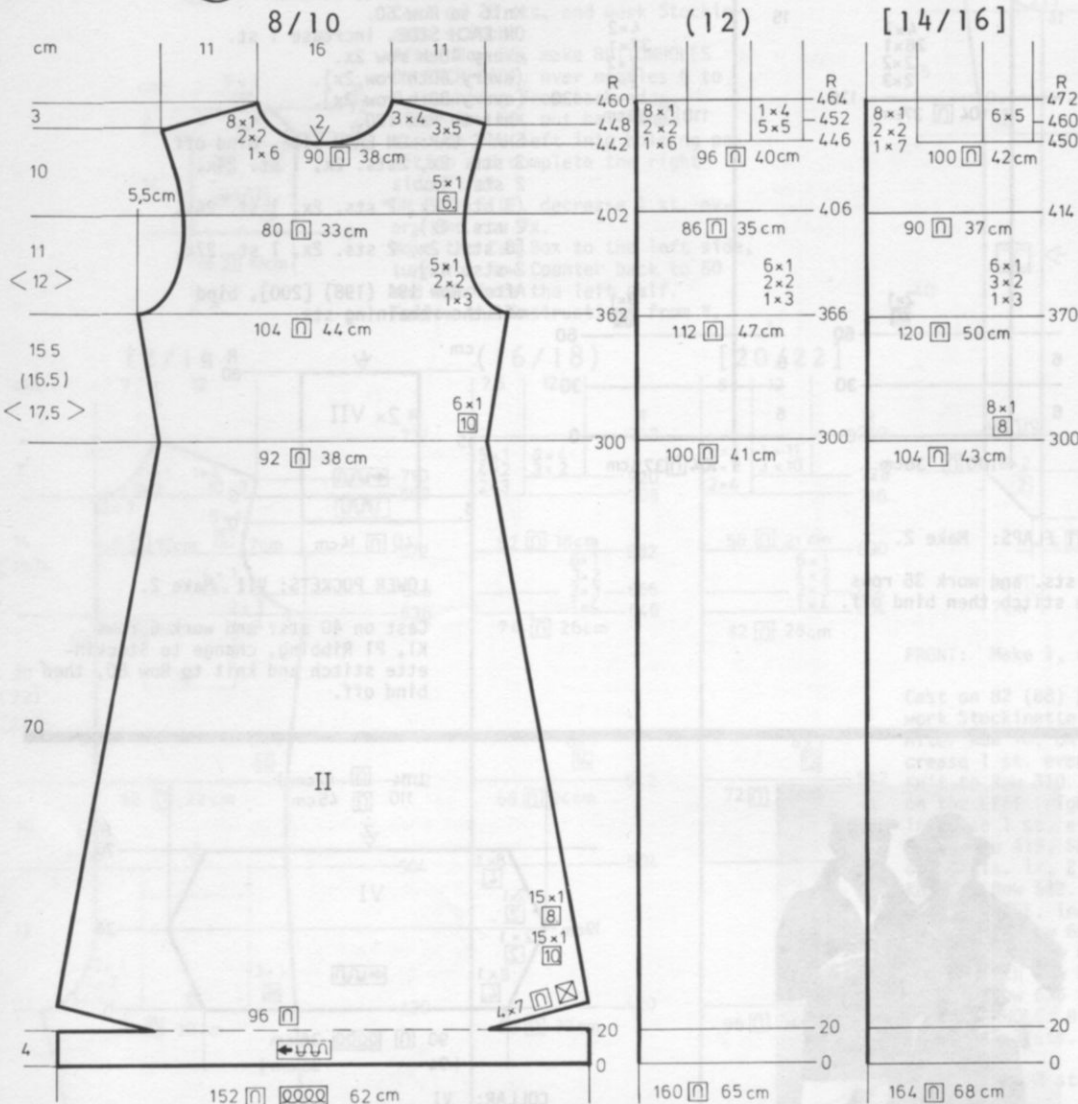

converta tape

For simple and speedy charting of custom knits.

List Price \$10.95

(California residents add Sales Tax)

Shipping charges: \$.65

Order direct from KNITKING

— 1128 Crenshaw Blvd., Los Angeles, California 90019

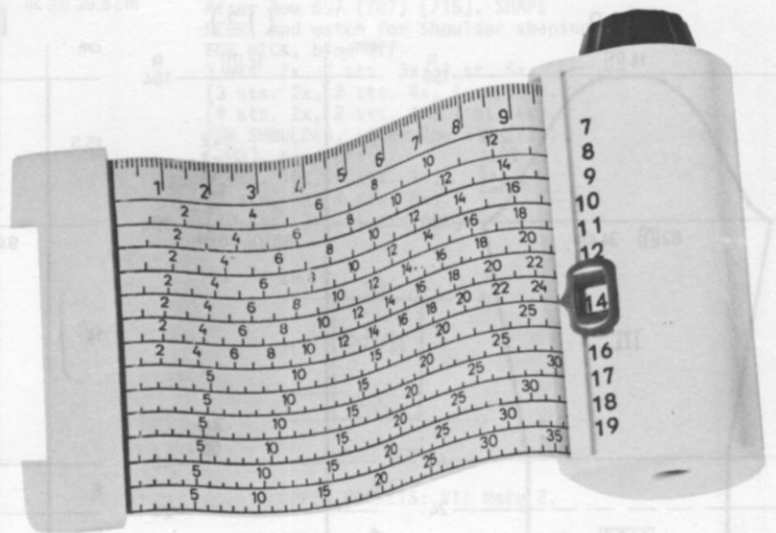

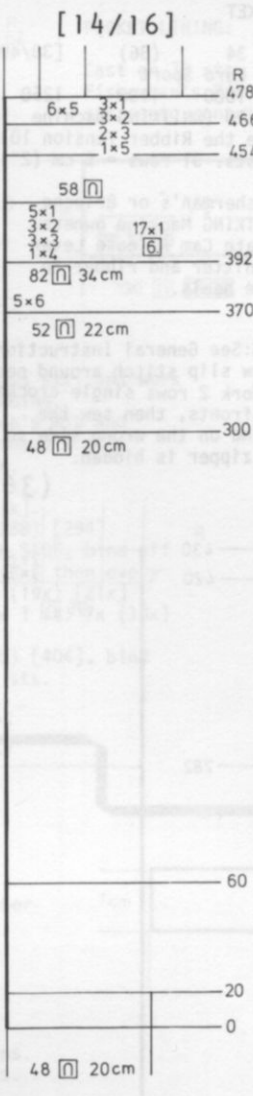
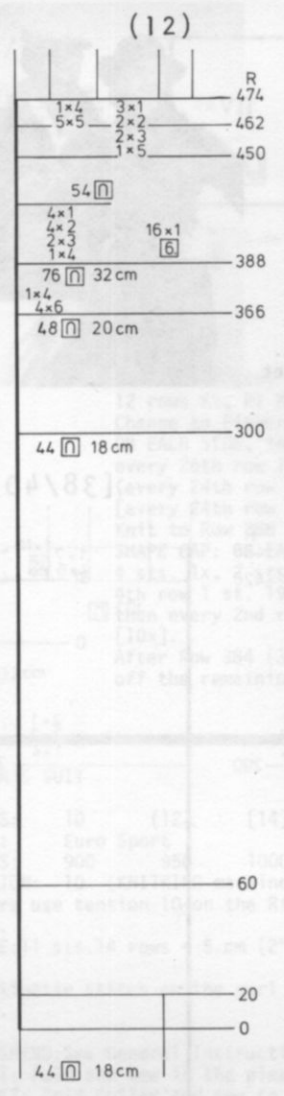
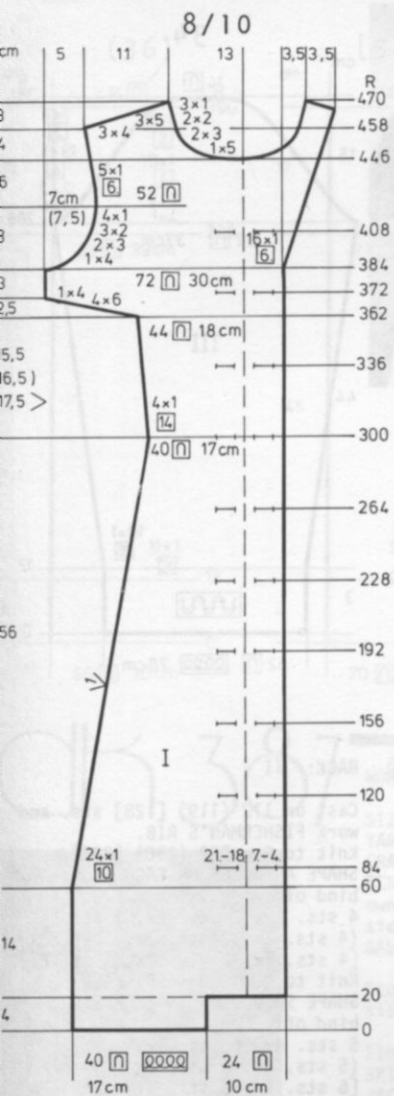

FRONT: I Make 1, reverse 1, and omit the buttonholes in 2nd section.

R 478
Cast on 40 (44) [48] sts. and work Stockinette stitch, turning the tension down 1 number to Row 20.
Change to garment tension and cast on 24 sts. on the right side (left for 2nd section).
Knit to Row 60.
ON SIDE EDGE, decrease 1 st. every 10th row 24x and AT THE SAME TIME, make BUTTONHOLES over needles 4 to 7 and 18 to 21, counting from the right edge after the rows shown on the Chart.
After Row 300, ON SIDE EDGE, increase 1 st. every 14th row 4x.
After Row 361 (365) [369], cast on 6 sts. 4x, 4 sts. 1x. (6 sts. 4x, 4 sts. 1x).
[6 sts. 5x].
After Row 384 (388) [392], SHAPE FRONT EDGE and ARMHOLE AT THE SAME TIME.
ON FRONT EDGE, increase 1 st. every 6th row 16x (16x) [17x] and FOR ARMHOLE, bind off 4 sts. 1x, 3 sts. 2x, 2 sts. 3x, 1 st. 4x. (4 sts. 1x, 3 sts. 2x, 2 sts. 4x, 1 st. 4x).
[4 sts. 1x, 3 sts. 3x, 2 sts. 3x, 1 st. 5x].
ON ARM SIDE, increase 1 st. every 6th row 5x.
After Row 446 (450) [454], SHAPE NECK:
Put 45 (47) [48] sts. on the LEFT (right for 2nd section) into holding position and complete the right side first.
ON NECK SIDE, for all sizes, bind off 5 sts. 1x, 3 sts. 2x, 2 sts. 2x, 1 st. 3x.
After Row 470 (474) [478], bind off the remaining sts.
Move the Cam Box to the left side, turn the Row Counter back to 446 (450) [454] and complete the left half.
ON NECK SIDE, make the bind-offs the same as you did for the right half and SHAPE SHOULDER after Row 457 (461) [465]: Bind off 4 sts. 3x, 5 sts. 3x. (5 sts. 5x, 4 sts. 1x). [5 sts. 6x].

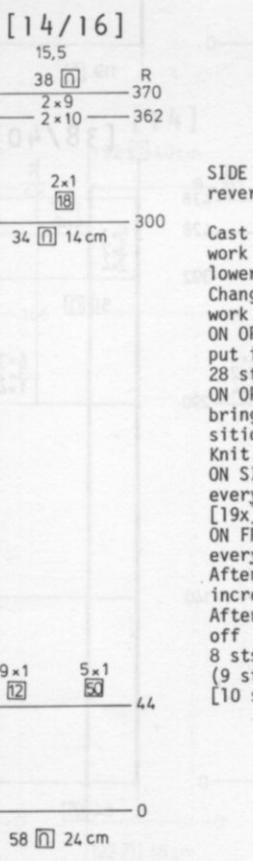
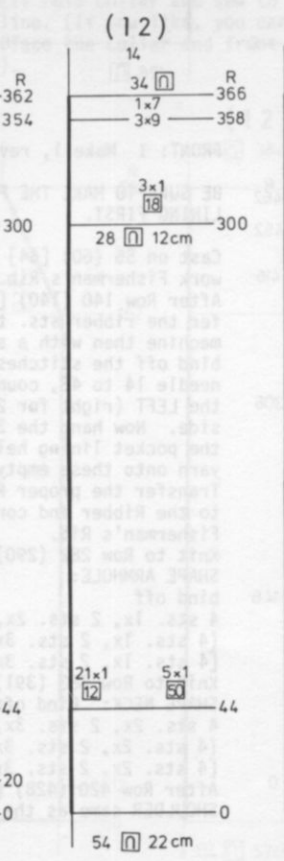
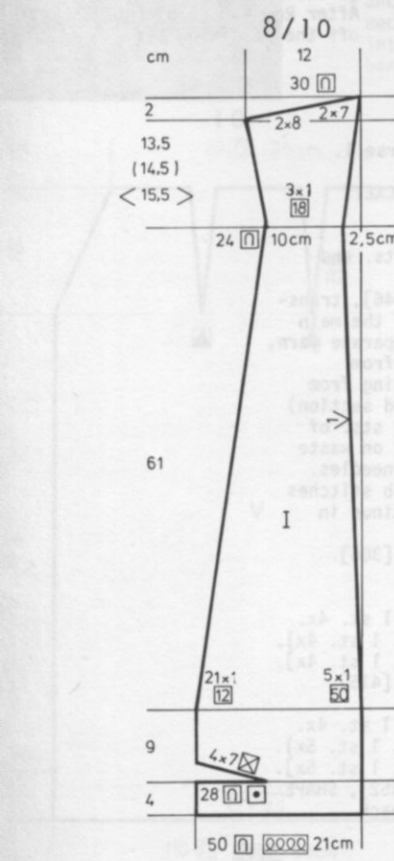

SIDE FRONT PANEL: I Make 1, reverse 1.

Cast on 50 (54) [58] sts. and work Stockinette stitch with lowered tension to Row 20.
Change to garment tension and work SHORT ROWS.
ON OPPOSITE SIDE OF CAM BOX, put into holding position 28 sts.
ON OPPOSITE SIDE OF CAM BOX, bring back into working position, 7 sts. 4x.
Knit to Row 44.
ON SIDE EDGE, decrease 1 st. every 12th row 21x (21x) [19x] and AT THE SAME TIME, ON FRONT EDGE, decrease 1 st. every 50th row 5x.
After Row 300, ON EACH SIDE, increase 1 st. every 18th row 3x.
After Row 353 (357) [361], bind off 8 sts. 2x, 7 sts. 2x. (9 sts. 3x, 7 sts. 1x). [10 sts. 2x, 9 sts. 2x].

hp 386

MAN'S JACKET

SIZES: 34 (36) [38/40]
 YARN: Euro Sport
 GRAMS: 1000 1100 1250
 TENSION: 10 (KNITTING machine owners use the Ribber Tension 10).
 GAUGE: 12 sts. 31 rows = 5 cm (2")

Double Fisherman's or Brioche Rib. KNITTING Machine owners, put the Gate Cam Release Lever of both knitter and ribber to the needle heels.

FINISHING: See General Instructions. Work 1 row slip stitch around pocket flaps. Work 2 rows single crochet down the fronts, then sew the zipper band on the wrong side so that the zipper is hidden.

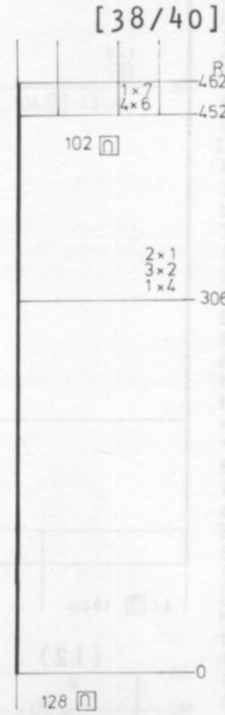
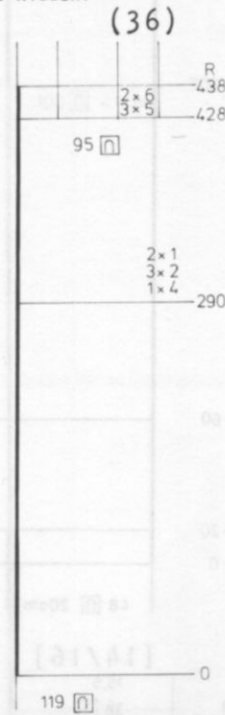
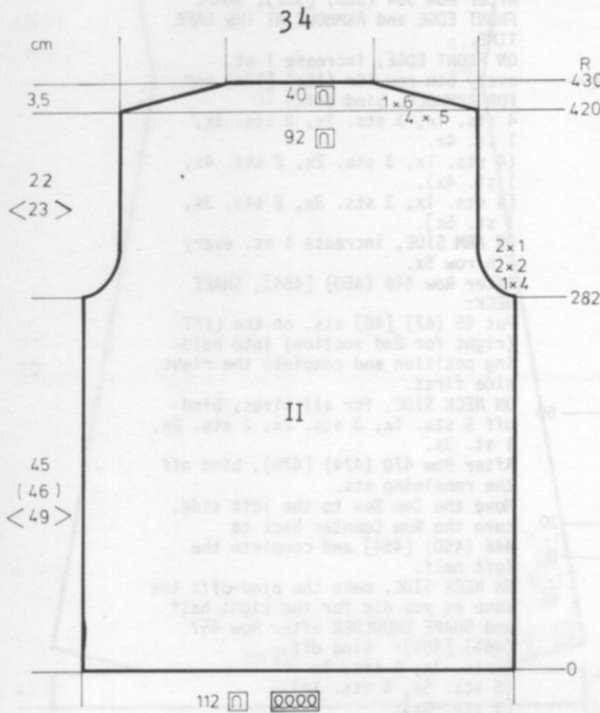
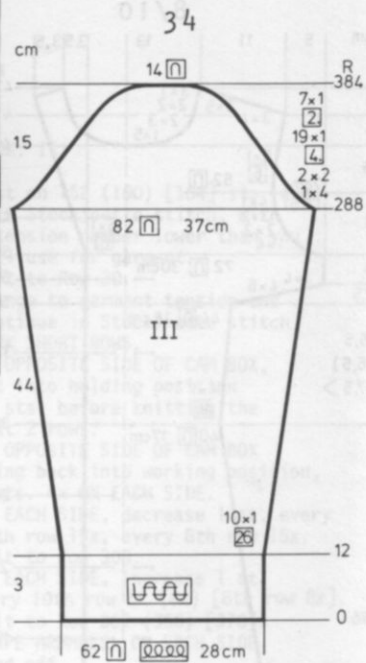

BACK: II

Cast on 112 (119) [128] sts. and work FISHERMAN'S RIB. Knit to Row 282 (290) [306]. SHAPE ARMHOLE: ON EACH SIDE, bind off 4 sts. 1x, 2 sts. 2x, 1 st. 2x. (4 sts. 1x, 2 sts. 3x, 1 st. 2x). [4 sts. 1x, 2 sts. 3x, 1 st. 2x]. Knit to Row 420 (428) [452]. SHAPE SHOULDER: ON EACH SIDE, bind off 5 sts. 4x, 6 sts. 1x, (5 sts. 3x, 6 sts. 2x). [6 sts. 4x, 7 sts. 1x]. After Row 430 (438) [462], bind off the remaining sts.

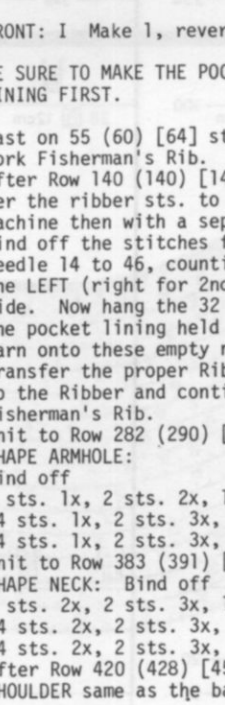
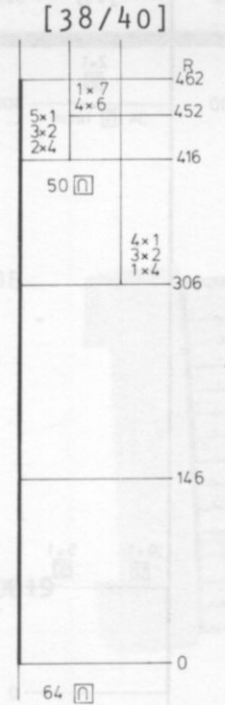
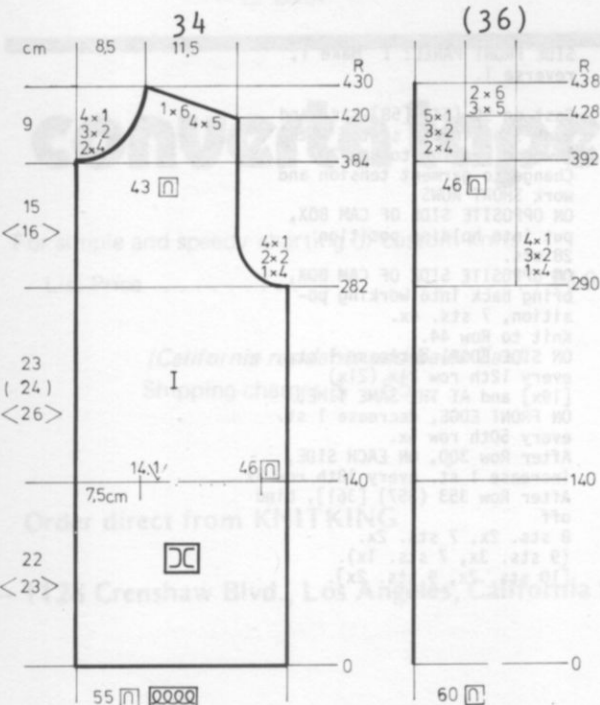

FRONT: I Make 1, reverse 1.

BE SURE TO MAKE THE POCKET LINING FIRST.

Cast on 55 (60) [64] sts. and work Fisherman's Rib. After Row 140 (140) [146], transfer the ribber sts. to the main machine then with a separate yarn, bind off the stitches from needle 14 to 46, counting from the LEFT (right for 2nd section) side. Now hang the 32 sts. of the pocket lining held on waste yarn onto these empty needles. Transfer the proper Rib stitches to the Ribber and continue in Fisherman's Rib. Knit to Row 282 (290) [306]. SHAPE ARMHOLE: bind off 4 sts. 1x, 2 sts. 2x, 1 st. 4x. (4 sts. 1x, 2 sts. 3x, 1 st. 4x). [4 sts. 1x, 2 sts. 3x, 1 st. 4x]. Knit to Row 383 (391) [415]. SHAPE NECK: Bind off 4 sts. 2x, 2 sts. 3x, 1 st. 4x. (4 sts. 2x, 2 sts. 3x, 1 st. 5x). [4 sts. 2x, 2 sts. 3x, 1 st. 5x]. After Row 420 (428) [452], SHAPE SHOULDER same as the back

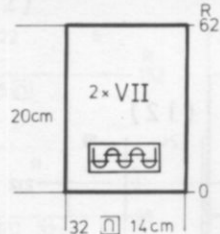
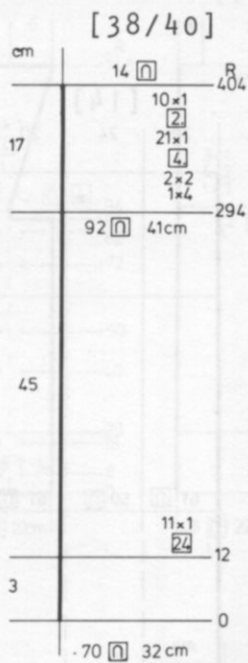
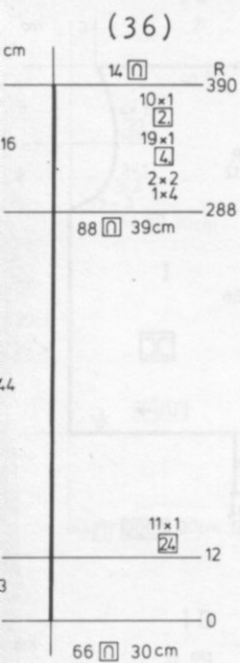

POCKET LINING: VII Make 2.

Cast on 32 sts. and work 62 rows Fisherman's Rib, then remove the sts. onto contrast waste yarn.

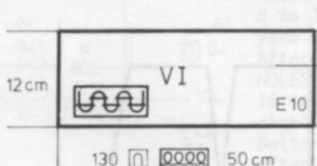

COLLAR: VI

Cast on 130 sts. and work K1, P1 Ribbing with garment tension to Row 40, then lower the tension 1 number and knit to Row 70. Bind off the crochet method for Ribbing.

SLEEVES: III

Cast on 62 (66) [70] sts. and work 12 rows K1, P1 Ribbing. Change to Fisherman's Rib and ON EACH SIDE, increase 1 st. every 26th row 10x. (every 24th row 11x). [every 24th row 11x]. Knit to Row 288 (288) [294]. SHAPE CAP: ON EACH SIDE, bind off 4 sts. 1x, 2 sts. 2x, then every 4th row 1 st. 19x (19x) [21x] then every 2nd row 1 st. 7x (10x) [10x]. After Row 384 (390) [404], bind off the remaining sts.

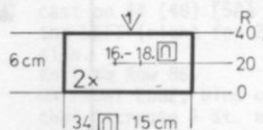

POCKET FLAP: Make 2.

Cast on 34 sts. and work Fisherman's Rib. After Row 20, make BUTTONHOLE over needles 16 to 18 counting from the left edge. Knit to Row 40 then bind off the crochet method for Ribbing.

ZIPPER BAND: Make 2.

Cast on 120 sts. and work 12 rows Fisherman's Rib, then bind off the crochet method for Ribbing.

dk 387

WOMAN'S SUIT

SIZES: 10 (12) [14]
YARN: Euro Sport
GRAMS: 900 950 1000
TENSION: 10 (KNITTING machine owners use tension 10 on the Ribber side.
GAUGE: 11 sts. 14 rows = 5 cm (2")

Stockinette stitch on the purl side.

FINISHING: See General Instructions.
SKIRT: Fold and sew in the pleats.
JACKET: Fold Collar and sew to neckline. (If you like, you can interface the collar and front band).

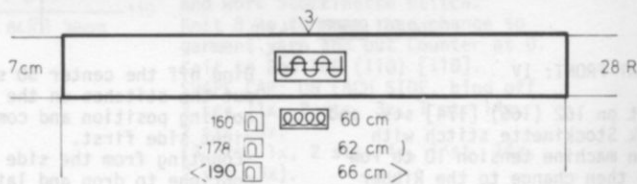

LOWER BAND:

Sew side seam of Jacket together first. Bring 160 (178) [190] needles into working position, then hang the sts. held on waste yarn omitting the front band sts. Decrease 20 sts. evenly across. Transfer every other st. to the Ribber and work 28 rows K1, P1 Ribbing then bind off the crochet method for Ribbing.

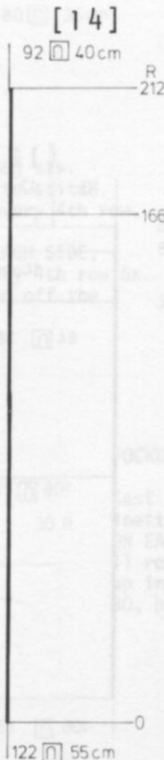
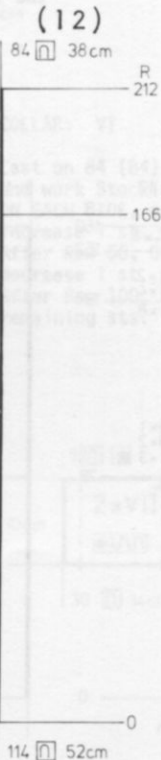
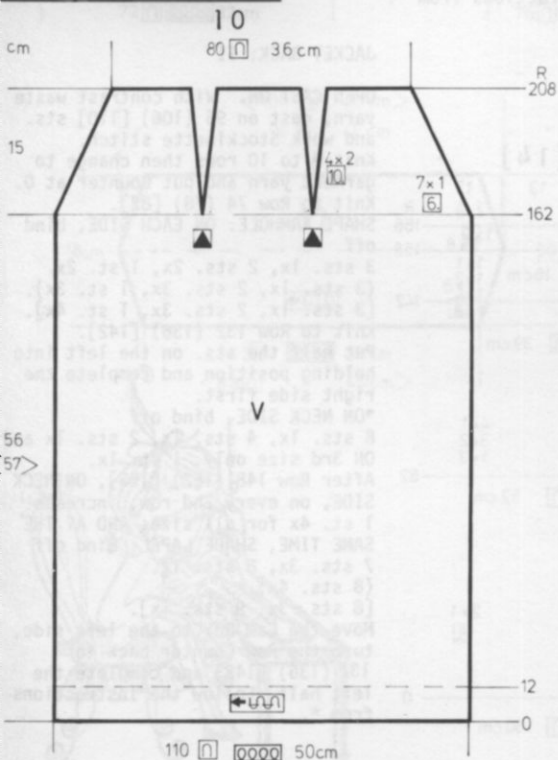

SKIRT BACK: V

Cast on 110 (114) [122] sts. and work Stockinette stitch. Use main machine tension 10 to Row 12, then change to the Ribber Tension 10. Knit to Row 162 (166) [166]. SHAPE DARTS AND SIDE EDGES AT THE SAME TIME. ON EACH SIDE, decrease 1 st. every 6th row 7x. Decrease 2 sts. for EACH DART every 10th row 4x. The first time, ON EACH SIDE, hang the 29th st. onto the 30th needle, the 33rd sts. to the 32nd needle and move the sts. in to fill the empty needles. The following dart decreases lie directly above. After Row 208 (212) [212], bind off the remaining sts.

Continued



dk 387

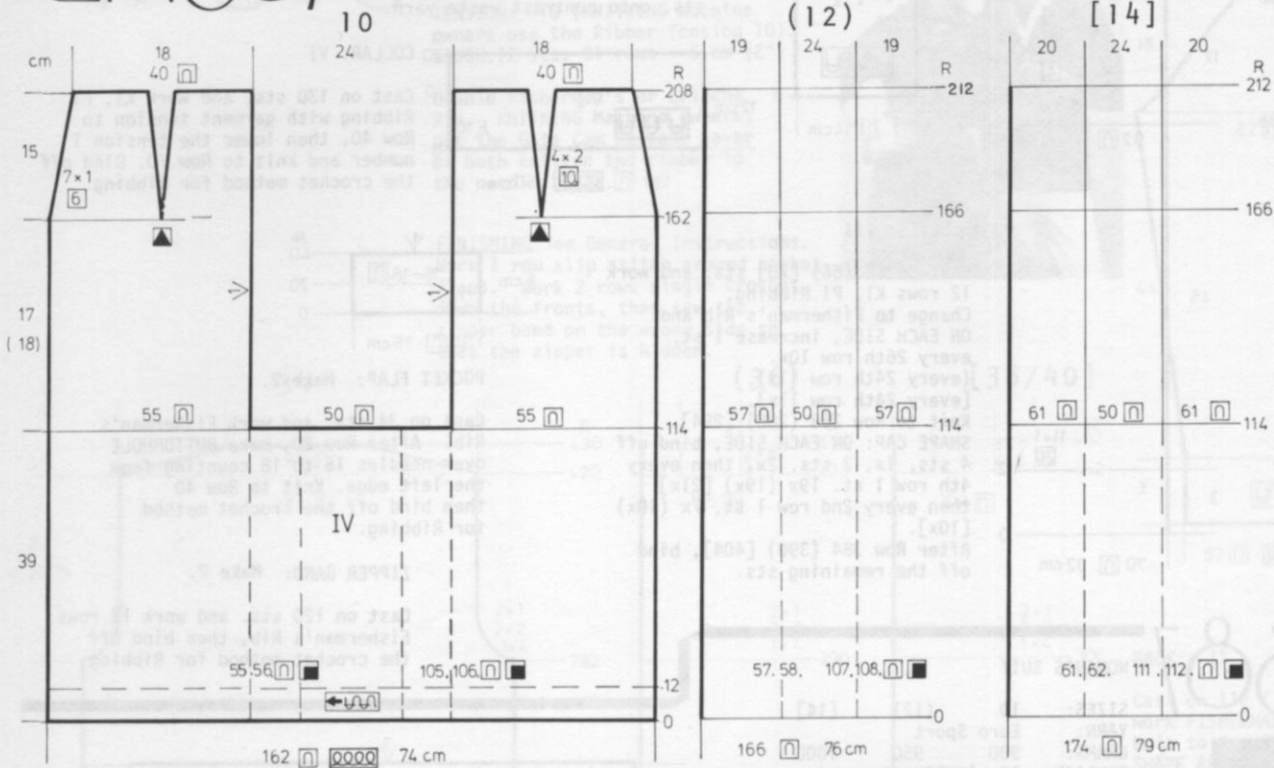

SKIRT FRONT: IV

Cast on 162 (166) [174] sts. and work Stockinette stitch with main machine tension 10 to row 12, then change to the Ribber tension 10.

*ON EACH SIDE, drop the 54th & 55th (56th & 57th) [60th & 61st] stitches and latch them up into knit stitches. REPEAT from * every 8 or 10 rows to Row 114.

Bind off the center 50 sts. and put the stitches on the left into holding position and complete the right side first.

*Counting from the side edge, continue to drop and latch up the 54th st. as you did before to the end of the skirt.

AT THE SAME TIME, after Row 162 (166) [166], SHAPE DART AND SIDE EDGE AT THE SAME TIME.

ON SIDE EDGE, decrease 1 st. every 6th row 7x.

Decrease 2 sts. for DART every 10th row 4x as you did on the back. For the first DART decrease, hang the 29th st. to the 30th needle, the 33rd to the 32nd needle and move the sts. in to fill the empty needles. The following DART decreases lie directly above.

After Row 208 (212) [212], bind off the remaining sts.

Move the Cam Box to the left side, turn the Row Counter back to 114 and complete the left side. Follow the instructions from *.

JACKET BACK: II

OPEN CAST ON. With contrast waste yarn, cast on 96 (106) [110] sts. and work Stockinette stitch.

Knit 8 to 10 rows then change to garment yarn and put Counter at 0. Knit to Row 74 (78) [82].

SHAPE ARMHOLE: ON EACH SIDE, bind off

3 sts. 1x, 2 sts. 2x, 1 st. 2x. (3 sts. 1x, 2 sts. 3x, 1 st. 3x). [3 sts. 1x, 2 sts. 3x, 1 st. 4x]. Knit to Row 132 (136) [142].

Put half the sts. on the left into holding position and complete the right side first.

*ON NECK SIDE, bind off 8 sts. 1x, 4 sts. 1x, 2 sts. 1x and ON 3rd size only, 1 st. 1x.

After Row 148 (152) [158], ON NECK SIDE, on every 2nd row, increase 1 st. 4x for all sizes AND AT THE SAME TIME, SHAPE LAPEL: Bind off 7 sts. 3x, 8 sts. 1x. (8 sts. 4x).

[8 sts. 3x, 9 sts. 1x]. Move the Cam Box to the left side, turn the Row Counter back to 132 (136) [142] and complete the left half. Follow the instructions from *.

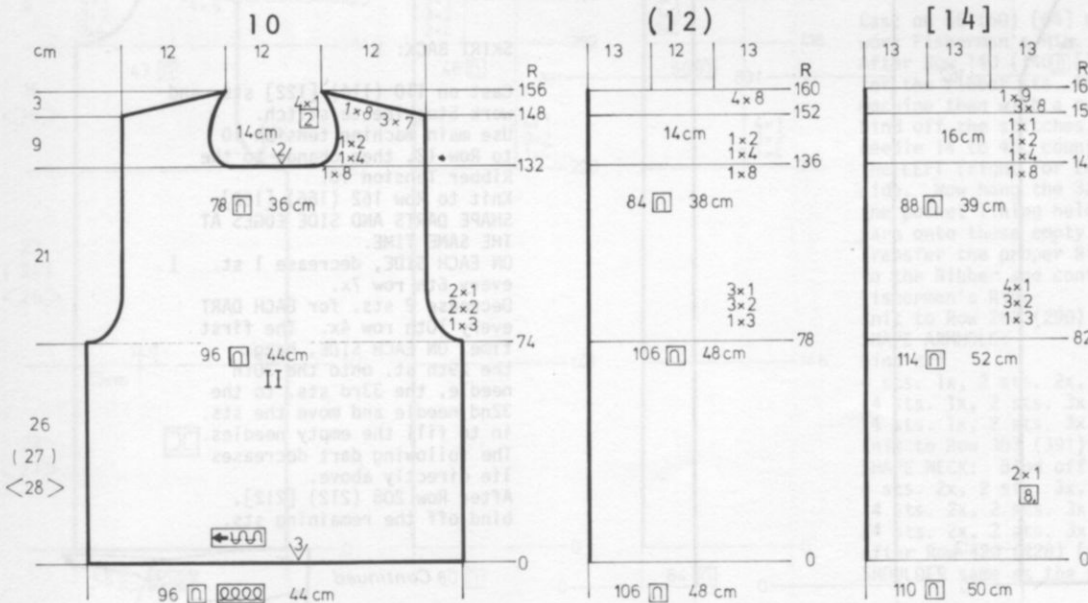

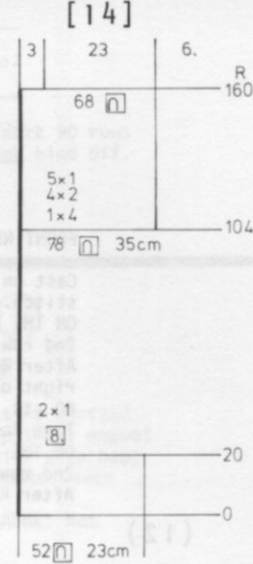
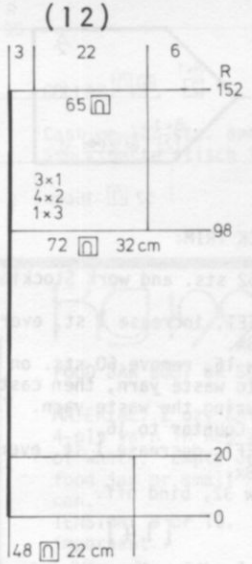
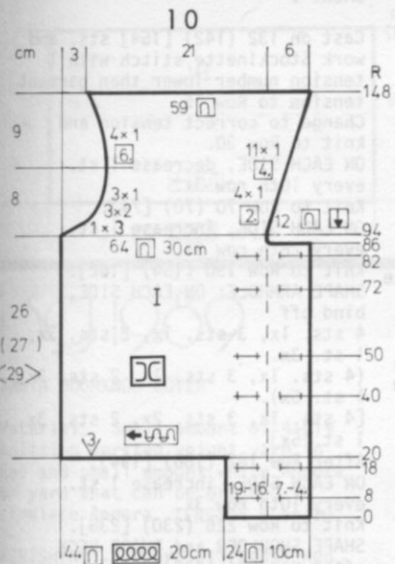

JACKET FRONT: I Make 1, reverse 1 and omit Buttonholes in 2nd section.

OPEN CAST ON. With contrast waste yarn, cast on 24 sts. Knit 8 to 10 rows, change to garment yarn and put Counter at 0. After Row 8 and 18, make BUTTON-HOLES over needles 4 to 7 and 16 to 19 counting from the right edge. Make the following Buttonholes over the same needles after the Rows shown on the Chart. After Row 20, with waste yarn, cast on 44 (48) [52] sts. on the LEFT (right for 2nd section) side.

Knit to Row 86. ON FRONT EDGE, bind off 12 sts. then increase 1 st. every 2nd row 4x, every 4th row 11x and AT THE SAME TIME, after Row 93 (97) [103], SHAPE ARMHOLE: Bind off 3 sts. 1x, 2 sts. 3x, 1 st. 3x. (3 sts. 1x, 2 sts. 4x, 1 st. 3x). [4 sts. 1x, 2 sts. 4x, 1 st. 5x]. ON ARM SIDE, for all sizes, increase 1 st. every 6th row 4x. After Row 148 (152) [160], bind off the remaining sts.

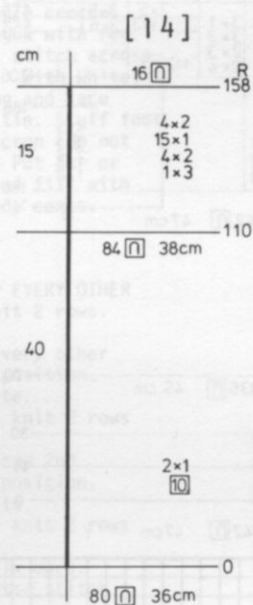
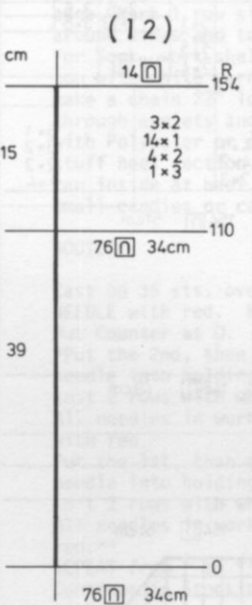
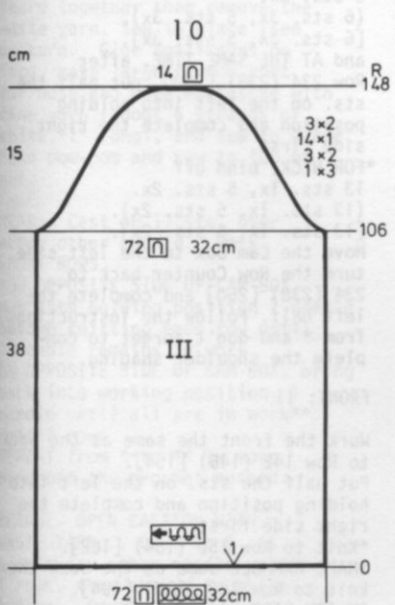

SLEEVE: III
OPEN CAST ON. With contrast waste yarn, cast on 72 (76) [80] sts. and work Stockinette stitch. Knit 8 to 10 rows then change to garment yarn and put Counter at 0. Knit to Row 106 (110) [110]. SHAPE CAP: ON EACH SIDE, bind off 3 sts. 1x, 2 sts. 3x, 1 st. 14x, 2 sts. 3x. (3 sts. 1x, 2 sts. 4x, 1 st. 14x, 2 sts. 3x). [3 sts. 1x, 2 sts. 4x, 1 st. 15x, 2 sts. 4x]. After Row 148 (154) [158], bind off the remaining sts.

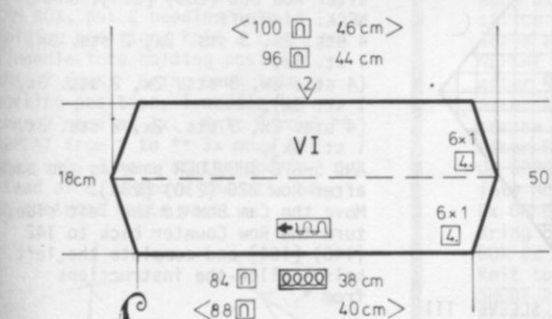
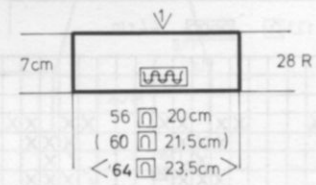

COLLAR: VI
Cast on 84 (84) [88] sts. and work Stockinette stitch. ON EACH SIDE, on every 4th row, increase 1 st. 6x. After Row 50, ON EACH SIDE, decrease 1 st. every 4th row 6x. After Row 100, bind off the remaining sts.

SLEEVE BANDS:
Bring 56 (60) [64] needles into working position. Hang the sleeve sts. held on waste yarn onto these needles, decreasing 16 sts. evenly across (See Practical Knitting Hint this issue). Transfer every other st. to the Ribber and work 28 rows K1, P1 Ribbing then bind off the crochet method for Ribbing.

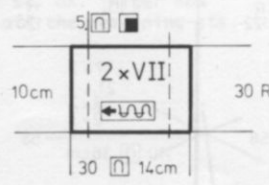

POCKET: VII Make 2.
Cast on 30 sts. and work Stockinette stitch. ON EACH SIDE, after every 10 or 11 rows, drop the 5th st. and latch up into a knit stitch. After Row 30, bind off.

dk 391

WOMAN'S PULLOVER

SIZES: 8/10 (12) [14]

YARN: Micaela

GRAMS:
 color 1 300 350 400
 color 2 50 50 50
 color 3 50 50 50

TENSION: 5 or 6
 GAUGE: 15 sts. 20 rows = 5 cm (2")

Stockinette stitch with embroidered Yoke as on the Line Drawing. Worn on the purl side.

FINISHING: See General Instructions Embroider Yoke following the Line Drawing.

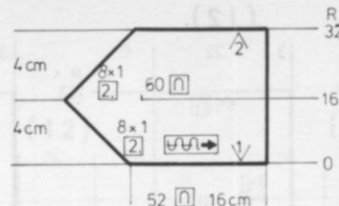
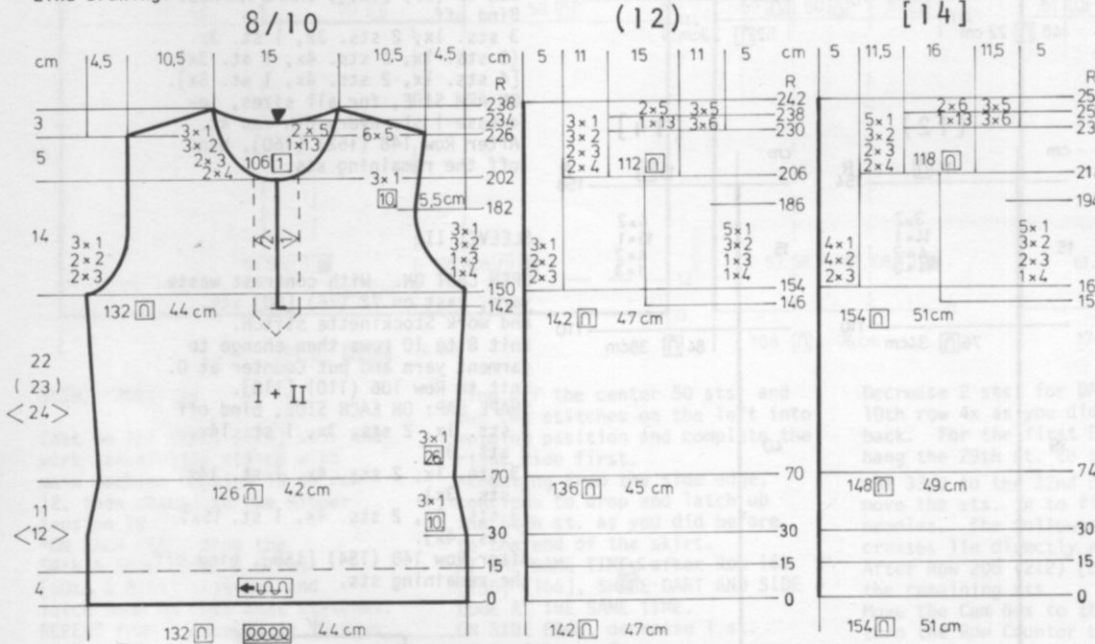

FRONT NECK TRIM:

Cast on 52 sts. and work Stockinette stitch.
 ON THE LEFT, increase 1 st. every 2nd row 8x.
 After Row 16, remove 60 sts. on the right onto waste yarn, then cast on 60 sts. using the waste yarn.
 Turn Row Counter to 16.
 ON THE LEFT, decrease 1 st. every 2nd row 8x.
 After Row 32, bind off.

BACK: I

Cast on 132 (142) [154] sts. and work Stockinette stitch with 1 tension number lower than garment tension to Row 15.
 Change to correct tension and knit to Row 30.
 ON EACH SIDE, decrease 1 st. every 10th row 3x.
 Knit to Row 70 (70) [74].
 ON EACH SIDE, increase 1 st. every 26th row 3x.
 Knit to Row 150 (154) [162].
 SHAPE ARMHOLE: ON EACH SIDE, bind off
 4 sts. 1x, 3 sts. 1x, 2 sts. 3x, 1 st. 3x.
 (4 sts. 1x, 3 sts. 1x, 2 sts. 3x, 1 st. 5x).
 [4 sts. 1x, 3 sts. 2x, 2 sts. 3x, 1 st. 5x].
 After Row 182 (186) [194], ON EACH SIDE, increase 1 st. every 10th row 3x.
 Knit to Row 226 (230) [238].
 SHAPE SHOULDER AND SHAPE NECK after Row 234 (238) [250].
 FOR SHOULDER, bind off 5 sts. 6x,
 (6 sts. 3x, 5 sts. 3x),
 [6 sts. 3x, 5 sts. 3x],
 and AT THE SAME TIME, after Row 234 (238) [250], put half the sts. on the left into holding position and complete the right side first.
 *FOR NECK, bind off
 13 sts. 1x, 5 sts. 2x.
 (13 sts. 1x, 5 sts. 2x).
 [13 sts. 1x, 6 sts. 2x].
 Move the Cam Box to the left side, turn the Row Counter back to 234 (238) [250] and complete the left half. Follow the instructions from * and don't forget to complete the shoulder shaping.

FRONT: II

Work the front the same as the back to Row 142 (146) [154].
 Put half the sts. on the left into holding position and complete the right side first.
 *Knit to Row 150 (154) [162].
 SHAPE ARMHOLE same as the back then knit to Row 182 (186) [194].
 ON ARM SIDE, increase 1 st. every 10th row 3x, AND AT THE SAME TIME, after Row 202 (206) [214], SHAPE NECK: Bind off
 4 sts. 2x, 3 sts. 2x, 2 sts. 3x, 1 st. 3x,
 (4 sts. 2x, 3 sts. 2x, 2 sts. 3x, 1 st. 3x),
 [4 sts. 2x, 3 sts. 2x, 2 sts. 3x, 1 st. 5x],
 AND SHAPE SHOULDER same as the back after Row 226 (230) [238].
 Move the Cam Box to the left side, turn the Row Counter back to 142 (146) [154] and complete the left half. Follow the instructions from *.

SLEEVE: III

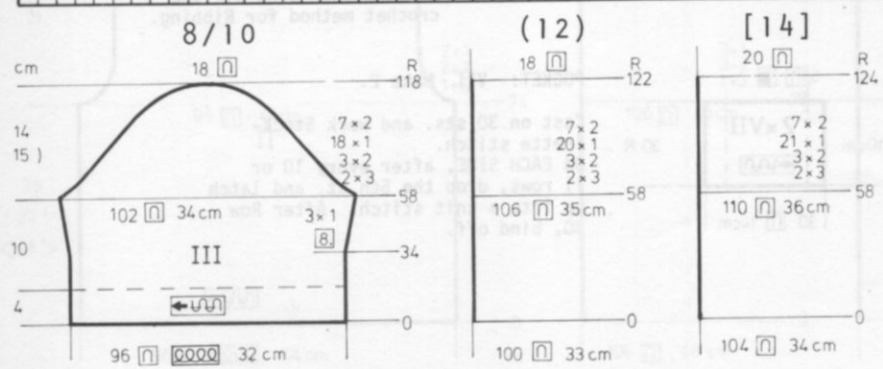
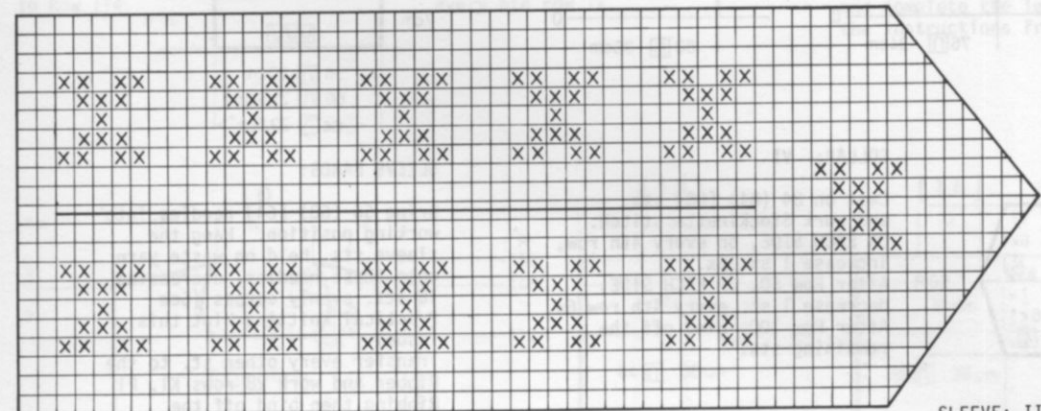

Cast on 96 (100) [104] sts. and work Stockinette stitch.
 Knit to Row 34.
 ON EACH SIDE, increase 1 st. every 8th row 3x.
 After Row 58, SHAPE CAP:
 ON EACH SIDE, bind off
 3 sts. 2x, 2 sts. 3x, 1 st. 18x,
 2 sts. 7x.
 (3 sts. 2x, 2 sts. 3x, 1 st. 20x,
 2 sts. 7x).
 [3 sts. 2x, 2 sts. 3x, 1 st. 21x,
 2 sts. 7x].
 After Row 118 (122) [124], bind off the remaining sts.

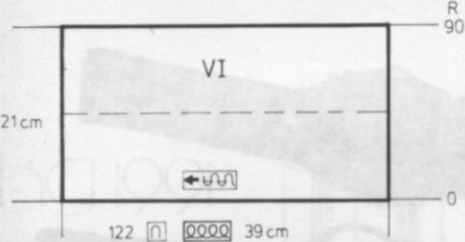

COLLAR: VI

Cast on 122 sts. and work 90 rows Stockinette stitch then bind off.

BELT:

Cast on 12 sts. with color 2 and work 330 rows Stockinette stitch. Change to color 3 and work 330 rows then bind off. Fold cords and sew them together. Make fringe for each end.

Kg 1989

SANTA DOORKNOB COVER

Material: Small amount of 4-ply knitting worsted weight yarn in Red and small amount white Angora or yarn that can be brushed to simulate Angora. TENSION 9 or 10.

FINISHING: Secure all ends. Run thread elastic around opening of head. Weave the open sts. of beard together then remove the waste yarn. Sew in place (see picture). Glue small eyes on face, make large french knot for nose and make mustache with fine yarn (about 6 strands of white, 1" long), and sew in place. Make pom-pom and sew to top of hat.

HEAD: Cast on 17 sts. over every other needle. Work SHORT ROWS.

*ON OPPOSITE SIDE OF CAM BOX, put into holding position 1 needle before knitting each row until 1 needle remains in work. ON OPPOSITE SIDE OF CAM BOX, bring back into working position, 1 needle until all are in work**. Knit 2 rows. REPEAT from * to ** 1x more. Bind off the crochet method.

BEARD: OPEN CAST ON WITH WASTE YARN... Cast on 6 sts. over every other needle. Knit 4 rows, then change to white Angora. Counter at 0. Knit 4 rows, then work SHORT ROWS. *ON OPPOSITE SIDE OF CAM BOX, put 2 needles into holding position, knit 2 rows, put 1 needle into holding position, knit 2 rows. Bring back into working position, 1 needle 1x, then 2 needles 1x. Knit 8 rows.** REPEAT from * to ** 3x more but knit only 3 rows at the end instead of 8. Remove the sts. on to contrast waste yarn.

Kg 1990

FOOD JAR BOOT OR SOCK

MATERIAL: 2 oz. Knitting worsted 4-ply yarn in Red and small amount of White. Empty Junior size baby food jar or small tomato-sauce can. TENSION: 9 or 10. GAUGE: Not important.

FINISHING: Weave foot seams on each side. Pull up cast on edge. Work 1 row single crochet around sides and tongue with red. For Sock, work shell stitch across top with white yarn. With White, make a chain 22" long and lace through eyelets and tie. Stuff foot with Polyester or dacron (do not stuff heel section. Put jar or can inside at heel and fill with small candies or candy canes.

BOOT:

Cast on 36 sts. over EVERY OTHER NEEDLE with red. Knit 2 rows. Put Counter at 0. *Put the 2nd, then every other needle into holding position, knit 2 rows with white. All needles in work, knit 2 rows with red. Put the 1st, then every 2nd needle into holding position, knit 2 rows with white. All needles in work, knit 2 rows red.** REPEAT from * to ** 1x more. Continue in Stockinette stitch with red. After Row 16, make eyelet on each side by hanging the 3rd stitch onto the 2nd needle, leave empty needles in work. REPEAT the eyelets on each side after Rows 20 and 24. After Row 26, ON EACH SIDE, decrease 1 st. every 2nd row 8x. After Row 40, work SHORT ROWS. ON OPPOSITE SIDE OF CAM BOX, put into holding position, 1 needle 6x ON EACH SIDE. Bring back 1 needle OPPOSITE CAM BOX 6x ON EACH SIDE. Knit to Row 78. REPEAT THE SAME SHORT ROWS 1x more. Knit to Row 116. ON EACH SIDE, ON EVERY 4th row, decrease 1 st. 8x. After Row 148, bind off the remaining sts.

SOCK:

Cast on 36 sts. over EVERY OTHER NEEDLE with red yarn. Knit 2 rows. *Eyelet on each side, 3rd st. on 2nd st. Leave empty needles in work. Knit 4 rows.* REPEAT from * to * 2x more. ON EACH SIDE, decrease 1 st. every 2nd row to Row 20. ON EACH SIDE, decrease 1 st. EVERY ROW to Row 24. (20 sts. remain in work). SHORT ROW for heel. ON OPPOSITE SIDE OF CAM BOX, put 1 needle into holding position before knitting each row until 8 remain in the center. ON OPPOSITE SIDE OF CAM BOX, bring back 1 needle until all are in work. Knit 10 rows. REPEAT the same short rows for toe till 8 remain in work. Bring back 1 needle till all are in work. Knit 10 rows. ON EACH SIDE, decrease 1 st. every 2nd row till 2 remain. Bind off.

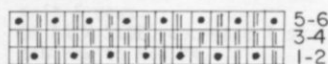
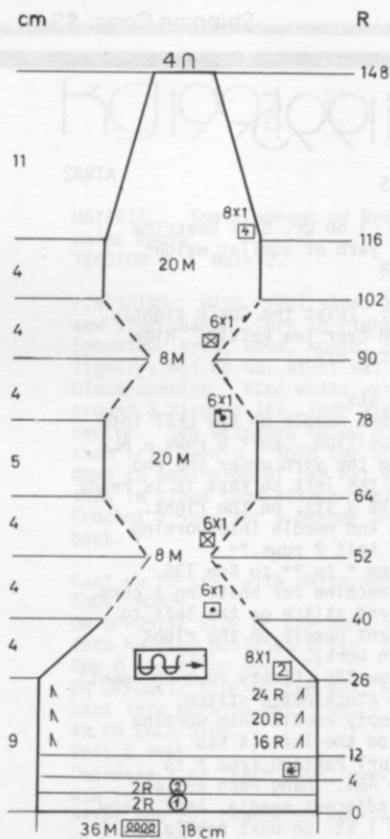

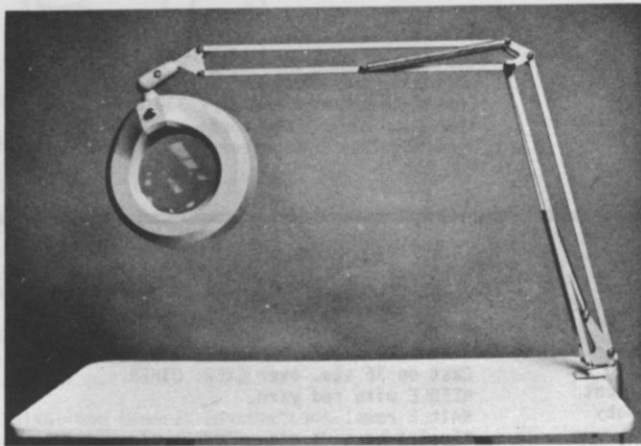

knitKING magnifier lamp

A perfect gift item for any knitter. It has a large (5") magnifying lens and a cool fluorescent tube light. It stays in any position and is wonderful for general illumination for you to work under when joining seams, etc. Color: light grey.

Price: \$69.50
(California residents add Sales Tax)
 Shipping Costs: \$3.00



knitKING carrying bags

Completely new design in heavy duty canvas with waterproof interior. For AM 3 Knitter and Yarn Container.

Price: \$46.50
 For Ribber only: \$23.00
(California residents add Sales Tax)
 Shipping Costs: \$1.75 and \$1.00

Order direct from KNITKING —
 1128 Crenshaw Blvd., Los Angeles, California 90019

Rg1995

PONY CURLS

MATERIAL: 1 50 gr. ball Beatrice Silver or yarn of similar weight.
 TENSION: 8

FINISHING: Twist the Curls tightly, then steam over tea kettle. Hide ends and cut off.

Cast on 4 sts.

*Put the end needle on the LEFT into holding position. Knit 6 rows - ALWAYS bring the yarn under the end needle on the left so that it is ready to knit the 3 sts. on the right. Bring the end needle into working position, knit 2 rows.**

REPEAT from * to ** to Row 136.

Set your machine for knitting a cord.

Hang the end stitch on the left to the adjacent needle on the right (3 sts. in work).

Knit to Row 326. (Empty rows do count).

Return to Stockinette stitch.

Bring 1 empty needle into working position on the left (4 sts.).

Knit in Curl Pattern from * to

** to Row 484. Hang each end st.

onto the adjacent needle, knit 1 row

then hang 1 st. on next needle and

bind off.



KG 1991

ANGEL

YARN: Amore.
1 50 gr. ball each of white & pink. Small amounts of yellow or brown for hair.
TENSION: 4. GAUGE: 17 sts. 26 rows = 5 cm (2")



FINISHING: With right sides together, sew up sides of head and body, turn to right side. Embroider face, then stuff lightly and sew up opening. Stuff body then work shell crochet across lower edge with white. Sew head to body. Cut strands of yarn for hair (yellow, brown or black) about 8 inches long. Tie in center. Cut 12 strands 5" long for back hair and front bangs. Sew bangs in place first, then sew center of 8" strands to top of head and arrange hair on each side and tuck in place if needed. Trim hair. Fold arms in half and sew center to back of neck. Bring hands around to front and cross (or arrange them as you like) and tuck in place. Gather wings in center and sew on back, covering the arms. Make a chain for hanging fold to make a loop and sew to back.

BODY: Make 2 in White

Cast on 7 sts. and work Stockinette stitch.
Knit 4 rows.
ON EACH SIDE, increase 1 st. every 4th row 4x, every 6th row 7x. (29 sts.) After Row 58, work SHORT ROWS: ON OPPOSITE SIDE OF CAM BOX, put into holding position 2 sts. 5x ON EACH SIDE. Bring all the needles back into working position before knitting the next 2 rows. Knit 1 row Tension 10, then bind off the crochet method.

HEAD: Pink.

Cast on 19 sts and work Stockinette stitch and SHORT ROWS.
ON OPPOSITE SIDE OF CAM BOX, put into holding position, 6 sts. at Row 0 and after Row 1.
ON OPPOSITE SIDE OF CAM BOX, bring back into working position ON EACH SIDE - 2 sts. 1x, 1 st. 1x, 2 sts. 1x, 1 st. 1x.
Knit 6 rows.
*ON OPPOSITE SIDE OF CAM BOX, put into holding position ON EACH SIDE 1 st. 1x, 2 sts. 1x, 1 st. 1x, 2 sts. 1x.**
ON OPPOSITE SIDE OF CAM BOX, bring back into working position ON EACH SIDE, 2 sts. 1x, 1 st. 1x, 2 sts. 1x, 1 st. 1x.
Knit 6 rows.
REPEAT from * to ** 1x.
Bring all the needles back into working position before knitting the next 2 rows. Knit 1 row Tension 10 then bind off the crochet method.

cast on

ARMS:

Set your machine for knitting a cord. Use Tension 3. Empty rows DO count. Cast on 5 sts. with Pink.
Knit 6 rows.
Change to White and knit 84 rows.
Change to Pink and knit 6 rows.
Bind off.

WINGS: Tension 4 or 5.

Follow the Line Drawing for the needle set-up, then cast on over the 11 needles in work using White.
*Counting from the LEFT, put needles 1, 2, 3, 4, 5, 6, 9 into holding position.
Knit 8 rows (do not wrap the yarn).
Bring needles 6 and 9 into working position, knit 2 rows.
Bring needles 4 and 5 into working position, needles 6 and 9 into holding position.
Knit 8 rows.
Bring needles 1, 2, 3, 6, 9 into working position, knit 2 rows.
Put needles 3, 6, 9 into holding position, knit 8 rows.
All needles in work, knit 2 rows.**
REPEAT from * to ** to Row 108 (Pattern will not be completed).
All needles in work, knit 1 row Tension 10 and bind off the crochet method.

KG 1992

BELLS

MATERIAL: Small amounts of Red or Green or White Micaela.
TENSION: Change Tensions as given.

FINISHING: Weave the inside seam then the outside seam. Pull up the 2 sts. held on doubled yarn and tie securely. With basic color, make a crochet chain for a hanger and sew to top of bell. Hang small silver or gold bell to dangle inside.

Cast on 29 sts.
Knit 4 rows EACH with Tensions 1, 3, 5, 7, 12 rows Tension 9, 4 rows EACH Tensions 7, 5, 3, 1.
Hang the cast-on sts. back onto the machine to form hem then remove the doubled sts. onto strand of yarn.

VARIATION: Instead of knitting the 12 center rows as given, knit 4 rows Tension 9 with basic color, then put every 3rd needle into holding position, knit 4 rows Tension 9 using contrast color. All needles in work, knit 4 rows basic color. Continue instructions as given. You may also put every 2nd needle into holding position and use the contrast color for 4 rows.

KG 1993

CHRISTMAS TREE

MATERIAL: Small amount Green Amore.
TENSION: 4. MAKE 2.

FINISHING: With WRONG sides together, pin sections. Begin at lower edge of tree section and work reverse single crochet around to base of trunk. Stuff lightly with dacron fibrefill, then finish crochet around trunk. Trim with Sequins. Make crochet hanger and sew to back at top of tree.

Cast on 3 sts. Knit 4 rows.
ON EACH SIDE, increase 1 st. (by bringing an extra needle into working position) every 6th row 3x, every 4th row 10x.
After Row 60, bind off 11 sts. beginning next 2 rows.
Knit 10 rows over 7 sts. After Row 74, bind off.

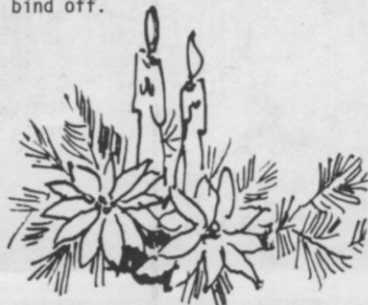

KG 1994

SANTA

MATERIAL: Small amount of Red and White Amore.
TENSION 4 Make 2.

FINISHING: With right sides together, sew side seams. Turn to right side. Embroider eyes, nose, mouth. Stuff lightly, but do not stuff hat section. Close opening. Wind white yarn around 3 fingers 16x, then tie in center. Sew whiskers below mouth, then trim evenly. Fold top of hat down to beginning of red hat and tuck in place then attach small bell. Crochet a loop for a hanger and sew to back.

Cast on 25 sts. with White and work SHORT ROWS.
ON OPPOSITE SIDE OF CAM BOX, put into holding position 8 sts. at Row 0 and after Row 1.
ON OPPOSITE SIDE OF CAM BOX, bring back into working position, 2 sts. 4x ON EACH SIDE.
Knit 6 rows.
Decrease 1 st. EACH SIDE, every 4th row 3x.
After Row 28, change to Red yarn.
Knit 12 rows.
ON EACH SIDE, decrease 1 st.
Knit 6 rows.
ON EACH SIDE, decrease 1 st. every 4th row to Row 74.
Hang the end st. on each side onto center needle and bind off.

DK 370 - Yarn: Crocus Crepe			
SIZES:	8/10	(12/14)	[16]
Regular Price	\$39.71	\$41.80	\$52.25
Sale Price	29.83	31.40	39.25
Shipping costs	1.65	1.65	2.15
DK 371 - Yarn: Allegro			
SIZES:	8/10	(12/14)	[16]
Regular Price	\$ 6.36	\$11.13	\$11.13
Sale Price	4.76	8.33	8.33
Shipping costs	1.00	1.00	1.00
DK 372 - Yarn: Allegro			
SIZES:	8/10	(12/14)	[16]
Regular Price	\$ 9.54	\$11.13	\$12.72
Sale Price	7.14	8.33	9.52
Shipping costs	1.00	1.00	1.00
DK 373 - Yarn: Allegro			
SIZES:	8/10	(12/14)	[16]
Regular Price	\$ 7.95	\$ 9.54	\$12.72
Sale Price	5.95	7.14	9.52
Shipping costs	1.00	1.00	1.00
DK 374 - Yarn: Allegro			
SIZES:	7/8	(10/12)	[14/16]
Regular Price	\$11.13	\$14.31	\$17.49
Sale Price	8.33	10.71	13.09
Shipping costs	1.00	1.00	1.65
DK 375 - Yarn: Allegro			
SIZES:	One Size		
Regular Price	\$ 7.95		
Sale Price	5.95		
Shipping costs	1.00		
DK 376 - Yarn: Allegro			
SIZES:	7/8	(10/12)	[14.16]
Regular Price	\$ 9.54	\$11.13	\$12.72
Sale Price	7.14	8.33	9.52
Shipping costs	1.00	1.00	1.00
HP 377 - Yarn: Euro Sport			
SIZES:	34/36	(38)	[40]
Regular Price	\$19.35	\$23.22	\$24.51
Sale Price	14.55	17.46	18.43
Shipping costs	1.65	1.65	1.65
KK 378 - Yarn: Binia			
SIZES:	5/6	(7/8)	[9/10]
Regular Price	\$16.68	\$19.49	\$22.24
Sale Price	12.48	14.56	16.64
Shipping costs	1.65	1.65	1.65
KK 379 - Yarn: Euro Sport			
SIZES:	5 to 6 years		
Regular Price	\$ 2.58		
Sale Price	1.94		
Shipping costs	.75		
DK 380 - Yarn: Cheri & Amore			
SIZES:	8	(12)	[14]
Regular Price	\$23.43	\$24.92	\$26.41
Sale Price	17.58	18.70	19.82
Shipping costs	1.65	1.65	1.65
KK 381 - Yarn: Euro Sport			
SIZES:	7/8	(9/10)	[11/12]
Regular Price	\$10.32	\$15.48	\$16.77
Sale Price	7.76	11.64	12.61
Shipping costs	1.00	1.65	1.65
DK 382 - Yarn: Summertime			
SIZES:	7/8	(10/12)	[14/16]
Regular Price	\$27.86	\$29.85	\$31.84
Sale Price	20.86	22.35	23.84
Shipping costs	1.65	1.65	1.65
DK 383 - Yarn: Summertime			
SIZES:	7/8	(10/12)	[14/16]
Regular Price	\$13.93	\$15.92	\$17.91
Sale Price	10.43	11.92	13.41
Shipping costs	1.65	1.65	1.65

DK 384 - Yarn: Micaela			
SIZES:	12/14	(16/18)	[20/22]
Regular Price	\$31.84	\$33.83	\$35.82
Sale Price	23.84	25.33	26.82
Shipping costs	1.65	1.65	1.65
DK 385 - Yarn: Summertime			
SIZES:	8/10	(12)	[14/16]
Regular Price	\$31.84	\$33.83	\$35.82
Sale Price	23.84	25.33	26.82
Shipping costs	1.65	1.65	1.65
HP 386 - Yarn: Euro Sport			
SIZES:	34	(36)	[38/40]
Regular Price	\$25.80	\$28.38	\$32.25
Sale Price	19.40	21.34	24.25
Shipping costs	1.65	2.15	2.15
DK 387 - Yarn: Euro Sport			
SIZES:	10	(12)	[14]
Regular Price	\$23.22	\$24.51	\$25.80
Sale Price	17.46	18.43	19.40
Shipping costs	1.65	1.65	1.65
DK 390 - Yarn: Micaela			
SIZES:	8/10	(12)	[14]
Regular Price	\$17.91	\$19.90	\$21.89
Sale Price	13.41	14.90	16.39
Shipping costs	1.65	1.65	1.65
DK 391 - Yarn: Micaela			
SIZES:	8/10	(12)	[14]
Regular Price	\$15.92	\$17.91	\$19.90
Sale Price	11.92	13.41	14.90
Shipping costs	1.65	1.65	1.65



WE FOUND THEM IN EUROPE.!!!

New Miracle fibre pressing cloths... absolutely perfect for knits, even for the normally hard to press yarns, especially tight twisted orlons and acrylics... We brought in a small quantity for test purposes and they have undergone severe tests by our experts and some selected customers.

These marvelous pressing cloths are available for the first time in America... and KNITKING has them exclusively... There are two cloths to each package and the price per package is \$2.75... We are introducing them at a Special Price of \$5.00 for two packets (4 cloths) plus Shipping costs 35¢. (California residents please add Sales Tax).

dk 384

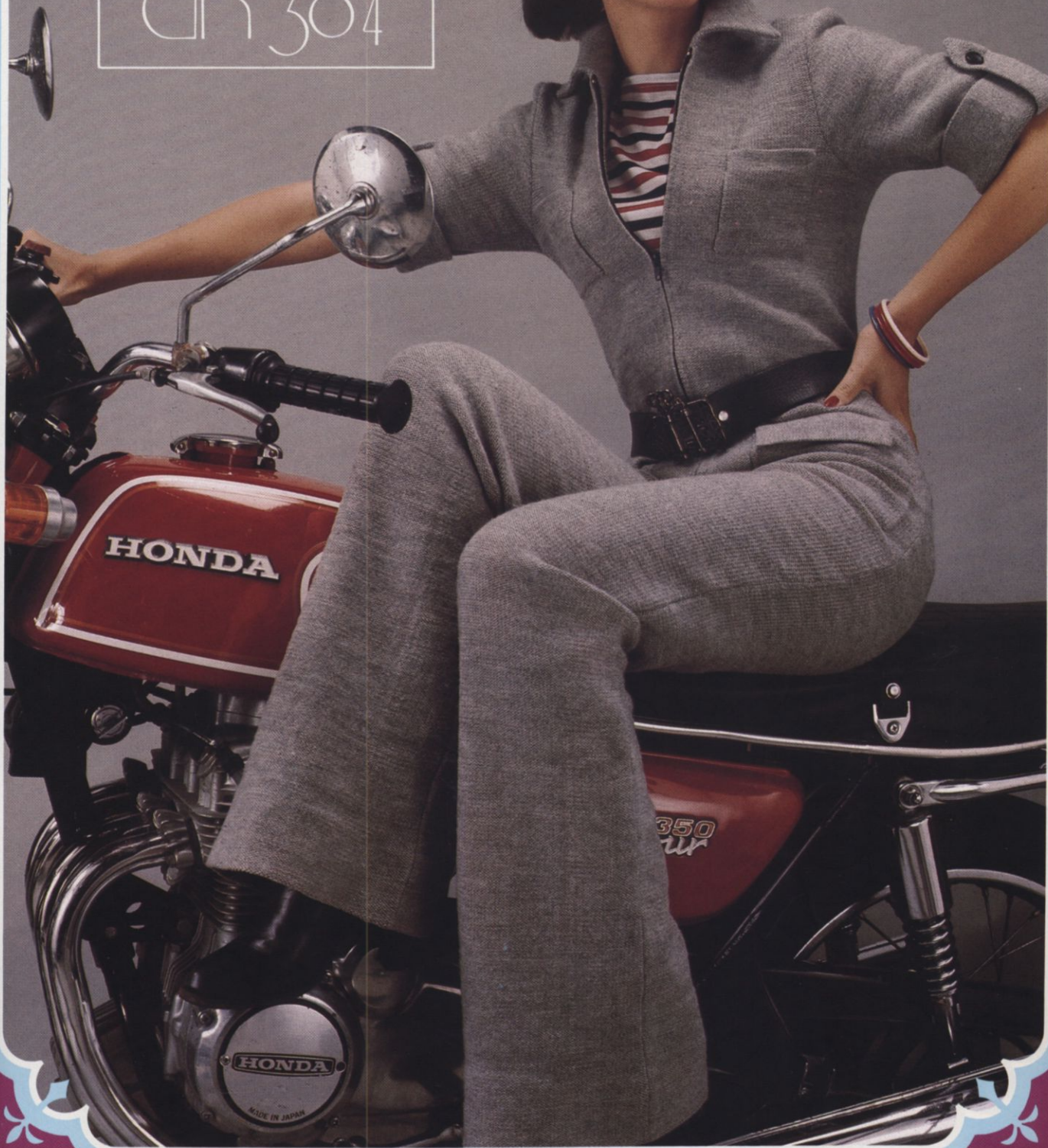







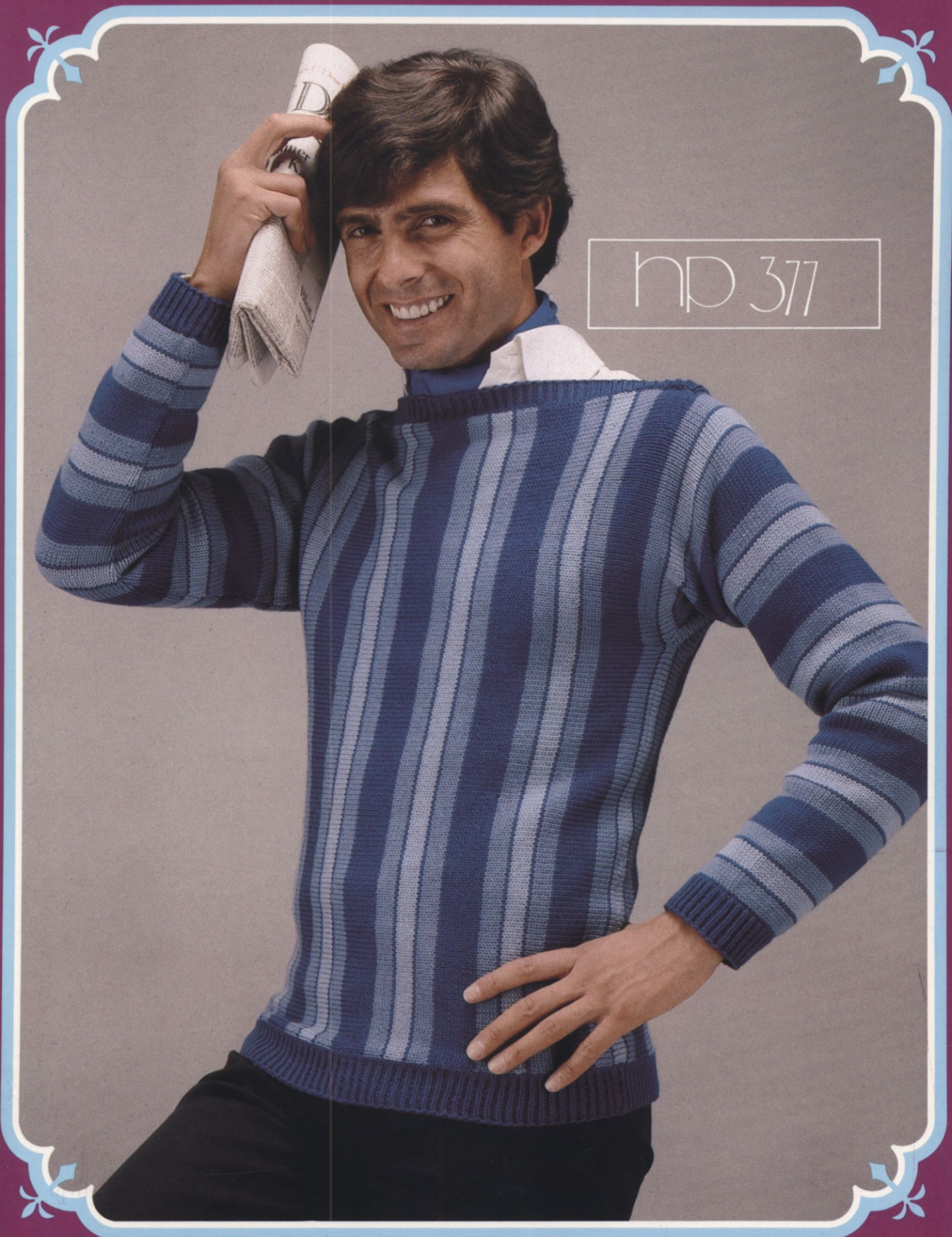

OK 366



hp 377

KK 381





KK 365

KK 367



KK 378

KK 379

KK 363

KK 364

