

Jones

pattern booklet no. 10





Abbreviations

M.B.	Main Bed	000	set counter at 000
st. st.	Stocking stitch	fol.	following
sts.	stitches	T.	tension
beg.	beginning	K.	Knit
dec.	decrease	M.D.E.	make double edge
inc.	increase	Ns.	needles
alt.	alternate	C.O.L. (R)	carriage on left (right)
trans.	transfer	patt.	pattern
opp.	opposite	rem.	remaining
carr.	carriage	H.C.L.	holding cam levers
S.D.	Side Dial	C.O.B.H.	cast on by hand
w.wl.	waste wool	in.	inch
m.wl.	main wool	oz.	ounce
m/c(s)	machine(s)	tub.	tubular
pos.	position	p.b.	part button

Trousers, Jumper and Cardigan Set



Materials

Jacket: 6 (7, 8) ozs. Robin Quicker Knit Bri Nylon.
Jumper: Col. A. 5 (5, 6) ozs. Robin 3 ply. Bri Nylon.
Col. B. 1 oz. Robin 3 ply Bri Nylon.
Trousers: Col. B. 5 (5, 6) ozs. Robin 3 ply Bri Nylon.
6 buttons for jacket.
6 buttons for jumper
 $\frac{1}{2}$ in. elastic (to desired length).

Measurements

To fit 18 (20, 22) in. chest.
Finished measurements:
Jacket: 19 (21, 23) in. chest.
Jumper: 18 (20, 22) in. chest.
Trousers inside leg: $8\frac{1}{2}$ (11, $13\frac{1}{2}$) ins.

Tension

Jacket: 7 sts. x $11\frac{1}{2}$ rows T8 equals 1 in.
Jumper: 9 sts. x 15 rows T4 equals 1 in.
Ribs: 10 sts. x 13 rows T3/3 equals 1 in.

Back

- 1 C.O.B.H. 68 (74, 80) sts. * T8. K. 7. T10. K. 1. C.O.R. 000 *.
- 2 70 (74, 78) rows straight.
- 3 Cast off 3 sts. at beg. of next 2 rows to 62 (68, 74) sts. C.O.R. 000.
- 4 Dec. 1 st. on each edge every 6th row, 3 times to 56 (62, 68) sts. 18 rows.
- 5 24 (28, 32) rows straight to shoulder.
- 6 Cast off 7 sts. at beg. next 4 rows, then cast off 4 (6, 8) sts. to 20 (22, 24) back neck sts. Thread up these sts.

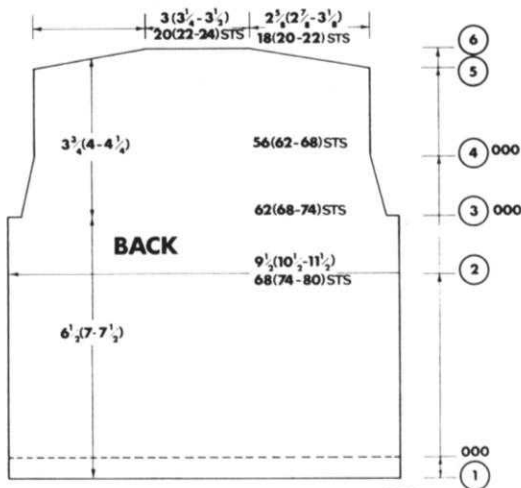

Left Front

(Repeat for right reversing all shaping)

- 1 C.O.B.H. 40 (42, 44) sts. As for 1 back * to *.
 - 2 54 (58, 62) rows. On front edge dec. 1 st. and every foll. 4th row, 7 times, then dec. 1 st. every 3rd row 8 times.
- At the same time** on left edge work steps 3, 4 and 5 as for back to row 16. 18 (20, 22) sts. K. to 24 (28, 32) rows to shoulder.
- 3 Cast off 3 sts. at beg. of next 2 rows to 46 (52, 58) sts. C.O.R. 000.
 - 4 Dec. 1 st. at beg. every row to row 18. 28 (34, 40) sts.
 - 5 Cast off 2 (3, 4) sts. at beg. of next 4 rows. Then dec. 2 sts. at beg. of next 4 rows. Cast off rem. 12 (14, 16) sts.
 - 6 As for back.

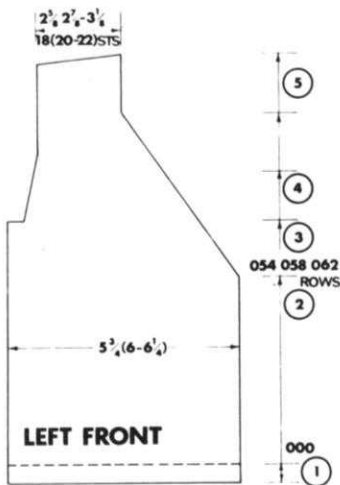

Sleeve

- 1 C.O.B.H. 48 (52, 56) sts. as for back 1 * to *.
- 2 Inc. 1 st. on each edge every 28 (22, 18) rows. 2 (3, 4) times to 52 (58, 64) sts. K. to 68 (74, 80) rows.
- 3 Cast off 3 sts. at beg. of next 2 rows to 46 (52, 58) sts. C.O.R. 000.
- 4 Dec. 1 st. at beg. every row to row 18. 28 (34, 40) sts.
- 5 Cast off 2 (3, 4) sts. at beg. of next 4 rows. Then dec. 2 sts. at beg. of next 4 rows. Cast off rem. 12 (14, 16) sts.

Press back and fronts; join shoulders. Rib band:—cast on 144 (152, 160) sts. as for 2 x 2 rib. T3/3. K. 4 rows tub. T6/6. K. 2 rows. Working from right edge cast off 4 to 7 sts. * Miss 4 (6, 8) sts. Cast off 4 sts. * Repeat once more * to * making 3 buttonholes. T6/6. K. 18 rows. Rib. transfer rib sts. to M.B.

Single bed Mc/s. C.O.B.H. 72 (76, 80) sts. as for 2 x 2 rib. T7. K. 2 rows. Make buttonholes K. 18 rows. M.D.E. 144 (152, 160) sts. With right side of work facing machine place side front to first 64 (66, 68) sts. back neck to 18 (20, 22) sts. Cast off up to this point, place remainder of sts. to rest of needles and cast off to end.

Press sleeves. Turn back hems of jacket and sleeves along foldline and stitch into place. Press. Stitch tops of sleeves into armholes. Join side and sleeve seams. Press all seams and press band, turning back collar, stitch to secure. Finish off buttonholes, sew on buttons to correspond with holes.

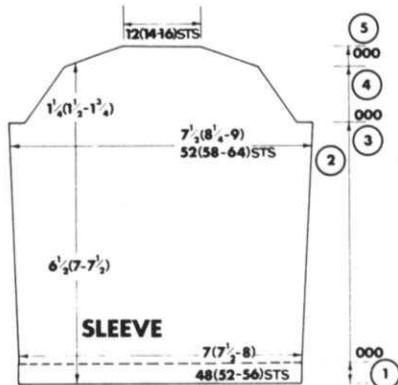

Right Trouser Leg (Reverse all shapings for left leg)

1 Cast on 82 (90, 98) sts. as for 2 x 2 rib. T2/2. 4 rows tub. C.O.R. 000. T3/3.

2 Inc. 1 st. every 6th (7th, 9th) row 18 times to 118 (126, 134) sts. K. to 110 (142, 174) rows.

3 Cast off 5 sts. K. 1 row. Cast off 8 sts. K. 1 row. C.O.R. 000. 105 (112, 131) sts.

4 On right edge dec. 1 st. every alt. row 9 times. 18 rows. **At the same time** on left edge dec. 1 st. every 12 (14, 15) rows. K. to 74 (84, 94) rows. 90 (98, 106) sts.

5 Cast off 45 (48, 51) Ns. K. 2 rows. Cast off 9 (10, 11) sts. at beg. of every alt. row 5 times to end.

Trouser Waist Band

Cast on 144 (152, 160) sts. as for 2 x 2 rib. T2/2. K. 4 rows tub. T3/3. K. 24 rows. Steam legs lightly, join front crutch. With right side of work facing machine, place work evenly along onto needles and cast off to end. Join back seam. Catch down waist band on inside, inserting $\frac{1}{2}$ in. elastic (to desired length). Close inside leg seams. Press seams.

Front and Back Jumper

1 Ribber. Cast on 82 (90, 98) sts. as for 2 x 2 rib. T2/2. 4 rows tub. T3/3. K. 12 rows. Trans. ribber sts. to M.B.

Single bed M/cs

1 C.O.B.H. 42 (46, 50) sts. as for 2 x 2 rib. T3. K. 12. T5. K. 1. T3. K. 12. M.D.E. T3. K. 1 row. C.O.R. 000.

2 K. 70 (78, 86) rows straight.

3 Cast off 3 (4, 5) sts. at beg. of next 2 rows to 76 (82, 88) sts. C.O.R. 000.

4 Dec. 1 st. each edge every 6th row 4 times to 76 (82, 88) sts. 24 rows. C.O.R. 000.

5 Start intarsia from graph at 000. On front knit 22 (26, 30) rows straight and cast off.

Press front and back.

Front Band

Ribber. Cast on 68 (74, 80) sts. as for 2 x 2 rib. T2/2. K. 4 rows tub. T3/3. K. 3 rows.

Buttonholes: working 3 (4, 5) needles in from left edge, cast off 4 needles * miss next 4 needles and cast off next 4 needles *. Repeat working from right edge, repeat 3 buttonholes. T3/3. K. 3 rows. With right side of work facing machine, place work onto needles and cast off to end.

Single bed M/cs. Cast on 34 (38, 40) sts. as for 2 x 2 rib. T3. K. 3. Make buttonholes as above T3. K. 3. T5. K. 1 row. T3. K. 3. Make buttonholes as above T3. K. 3. M.D.E. 68 (76, 80) sts.

Shoulder Ribs

1 Cast on 90 (94, 98) sts. as for 2 x 2 rib. T2/2. K. 4 rows tub. C.O.R. 000. T3. K. 16 rows rib. C.O.R. 000.

2 Thread up left 31 (33, 35) sts. and take off m/c. Cast off centre 28 sts. leaving 31 (33, 35) sts. K. 6 rows. C.O.R. 000.

3 Inc. 1 st. on left edge every alt. row 5 times, first inc. at 000, to 36 (38, 40) sts. 10 rows. Cast off. For left, place sts. back onto machine and repeat from **2** reversing all shapings.

For Single bed M/cs. 1 Cast on 46 (48, 50) sts. as for 2 x 2 rib. T4. K. 16 rows and continue from **2** as for rib.

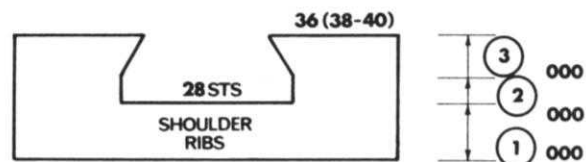
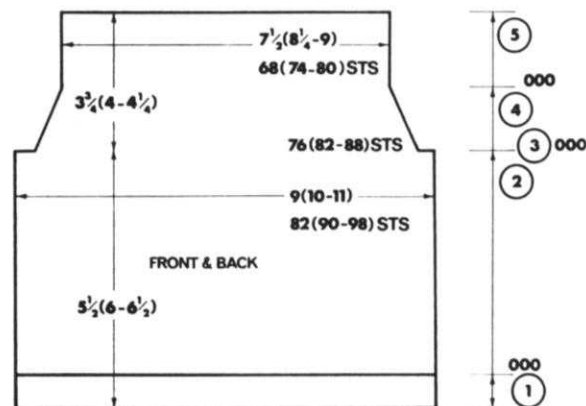
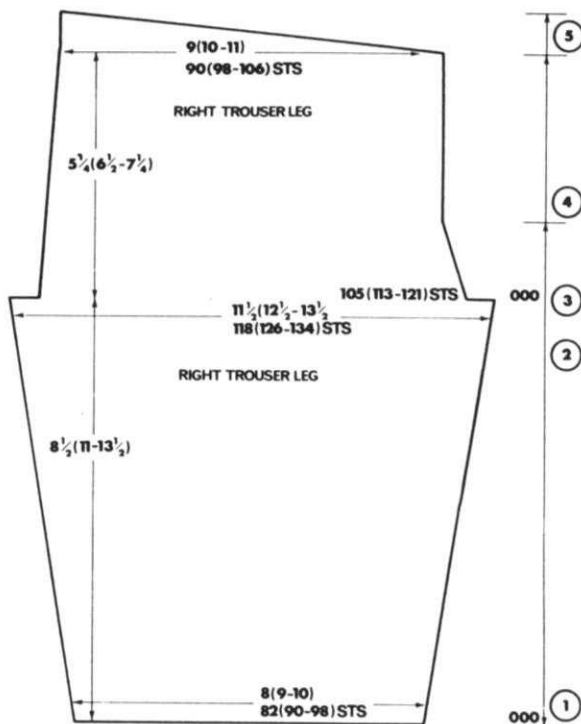

Top and Trousers

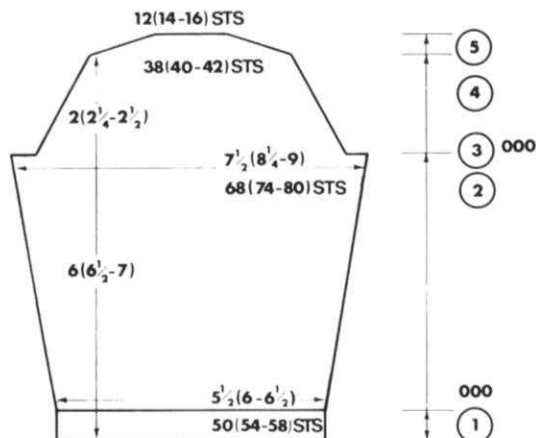

Sleeve

1 Cast on 50 (54, 58) sts. as for 2 x 2 rib as for **1** back. **Single bed M/cs.** 26 (28, 30) sts. as for 2 x 2 rib as for **1** back. C.O.R. 000.

2 Inc. 1 st. on each edge every 8th row 9 (10, 11) times to 68 (74, 80) sts. K. to 78 (86, 94) rows.

3 Cast off 3 (4, 5) sts. at beg. next 2 rows to 62 (66, 70) sts. C.O.R. 000.

4 Dec. 1 st. on each edge every 3rd row 6 (8, 10) times, then dec. 1 st. every alt. row 6 (5, 4) times to 38 (40, 42) sts. K. to 30 (34, 38) rows.

5 Cast off 4 sts. at beg. next 2 rows, then cast off 3 sts. at beg. next 6 rows, to 12 (14, 16) sts. Cast off rem. sts.

Press sleeves. Join top of back to shoulder ribs seam. Crochet round neck edge. Pin front band onto edge of shoulder, stitch tops of sleeves into armholes, securing band and ribs. Finish off buttonholes. Sew on buttons to correspond with holes. Join side and sleeve seams. Press all seams and bands.

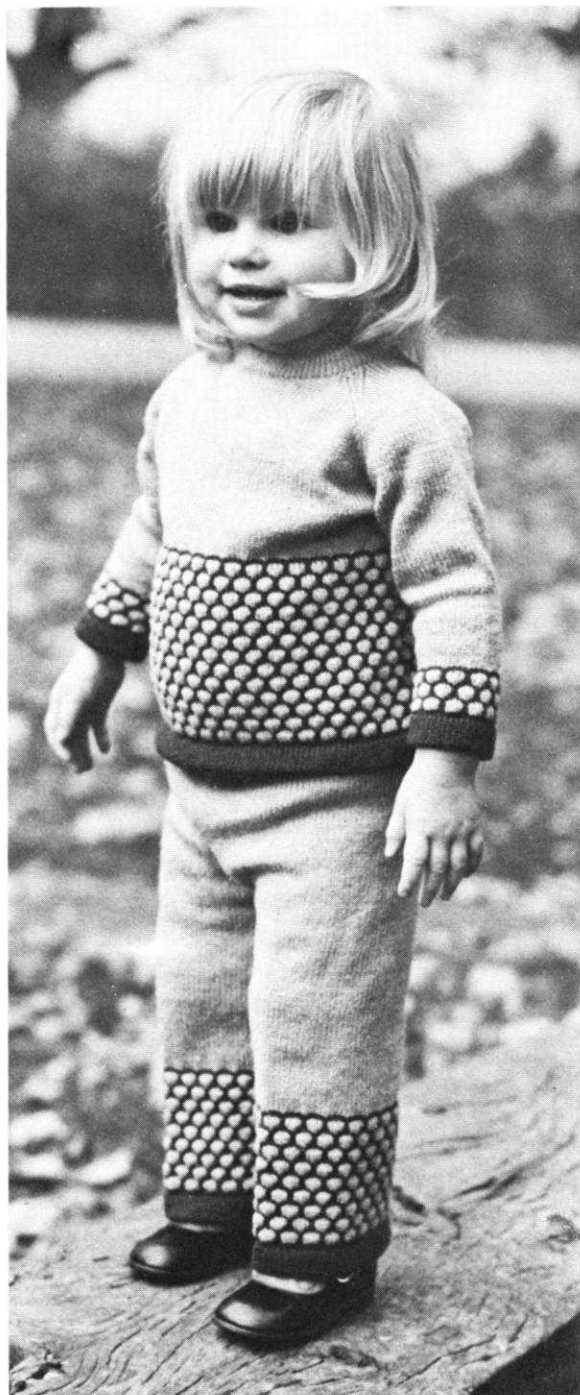
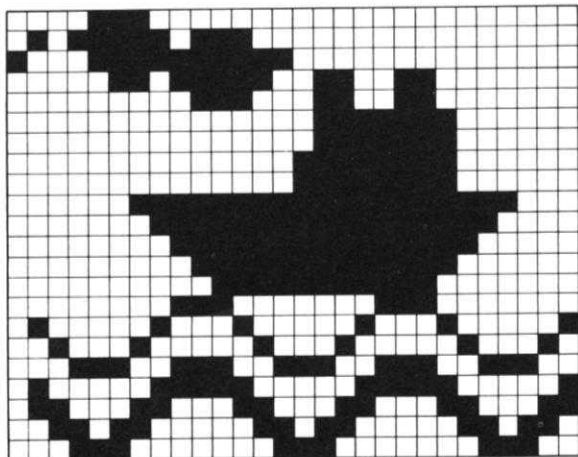

Child's Cardigan and Trousers

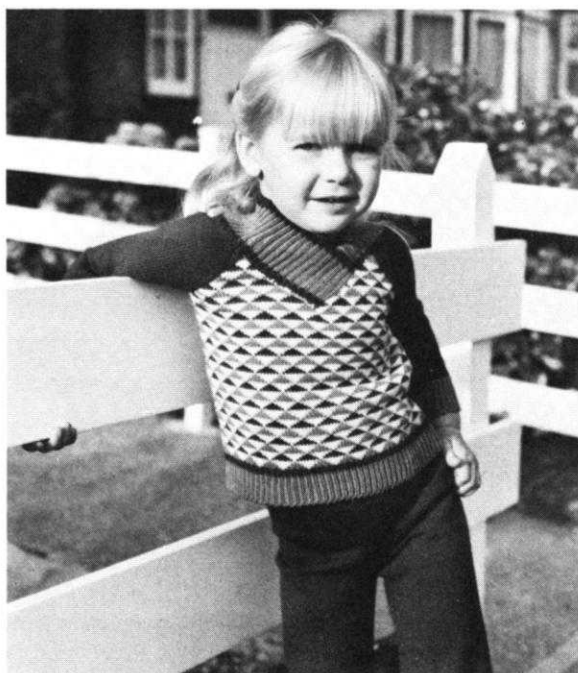
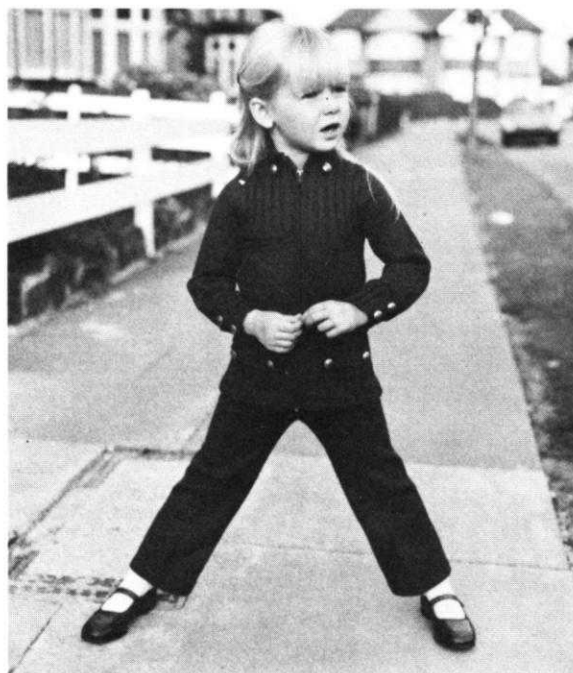

FOR MACHINES WITH RIBBERS ONLY

Materials

Jacket A 12 ozs. Col. A. Lister or Lee Target

Jacket B 8 ozs. Col. A. Tricel/Nylon 4 ply.
4 ozs. Col. B.

Jacket A 16 ins. jacket zip, 10 buttons

Jacket B 4 buttons

Measurements

To fit 22 (24, 26) ins. chest.

Inside trouser leg 13½ (16, 18½) ins.

Tension

7½ sts. x 11 rows = 1 in. over st. st. T5.

7½ sts. x 14 rows = 1 in. over 3 x 3 rib T3/3.

8 sts. x 10 rows = 1 in. over jacquard T6.

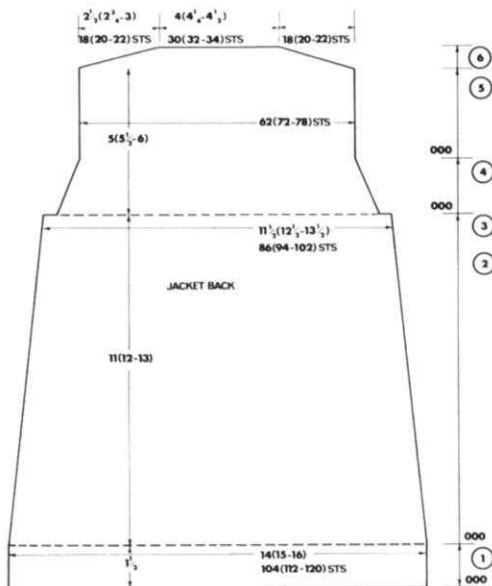

Jacket Back

1 Cast on 104 (112, 120) sts. T4. K. 15. T6. K. 1. C.O.R. 000 T5.

2 Dec. 1 st. on each edge every 13 (14, 15) rows 9 times to 122 (132, 142) sts. K. to 122 (132, 142) rows.

3 Cast off 6 (7, 8) sts. at beg. next 2 rows to 76 (80, 86) sts. C.O.R. 000. Trans. NS. to ribber bed for 3 x 3 rib. Change colour for jacket B. Start patt. See note.

4 Dec. 1 st. on each edge every 7th row, 4 times to 62 (72, 78) sts. 28 rows.

5 42 (50, 58) rows to shoulder.

6 Cast off 3 sts. at beg. next 8 rows then cast off 3 (4, 5) sts. at beg. next 4 rows. Cast off rem. 30 (32, 34) back neck sts.

NOTE: Step 3. For ribber attachment, working from left trans., 4th to 6th NS to ribber miss 3 sts. and trans. next 3 NS repeat across m/c.

N.B.

For jacket B with the 3 x 3 rib use the foll. On the m/c bring forward to E pos. the centre needle of every group of three. K. 4 rows with these needles forward. K 2 rows with all needles in B. pos. then bring forward the centre needle of the alternate groups of three and repeat as above.

Materials

Trousers A 8 (9, 9) ozs. Col. A. Lister or Lee Target.

Knickerbockers B 6 (7, 9) ozs. Col. A. Tricel/Nylon 4 ply.
2 ozs. Col. B.

½ in. elastic (to desired length) for waistband and knickerbockers cuffs.

Jumper A 4 ozs. Col. A.

3 ozs. Col. B. Tricel/Nylon 4 ply.

1 oz. each of 2 contrast colours.

Jumper B 1 oz. Col. A.

7 (8, 8) ozs. Col. B.

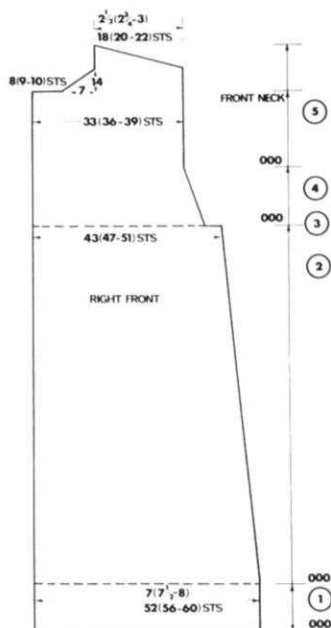

Right Front

1 Cast on 52 (56, 60) sts. as for 1 back.

2 As for back to 43 (47, 51) sts.

3 As for back to 37 (40, 43) sts. C.O.R. 000. Trans. NS for 3 x 3 rib (change col. for Jacket B).

4 As for back to 33 (36, 39) sts. C.O.R. 000.

5 K. 26 (34, 42) rows to front neck. K. 1 row cast off 8 (9, 10) sts. on neck. K. 1. Dec. 1 st. every alt. row on neck edge, 7 times 42 (50, 58) rows.

6 Cast off shoulder sts. as for back. Repeat for left front, reversing all shapings.

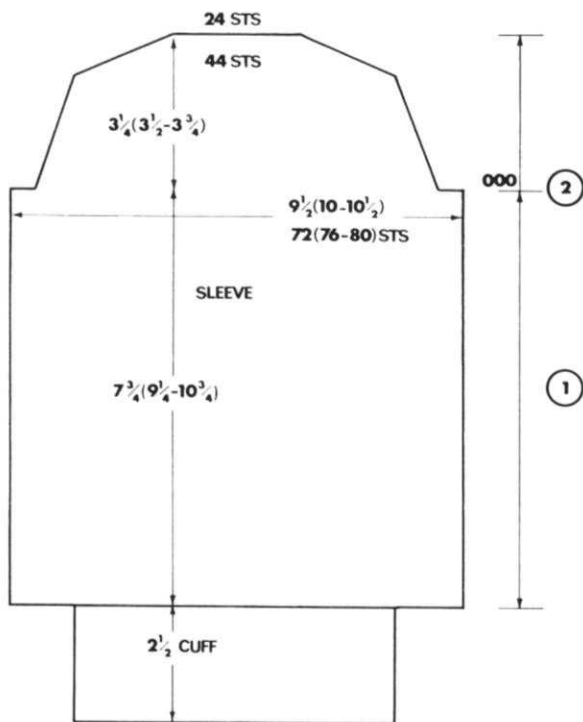

Sleeve

- Cast on 72 (76, 80) sts. K. 86 (102, 118) rows.
- Cast off 6 (7, 8) sts. at beg. next 2 rows to 60 (62, 64) sts. C.O.R. 000.
- Dec. 1 st. on each edge every 3rd row 8 (9, 10) times to 44 sts. K. to 26 (28, 30) rows.
- Dec. 1 st. on each edge every row 10 times to 24 sts. K. 1 row. Cast off. Repeat sleeve.

Cuff

Ribber Cast on 60 (66, 72) sts. on col. A for jacket A or in colour B for jacket B as for 3 x 3 rib (see N.B.). K. 35 rows of patt. Cast off.

Cuff band Jacket A

Cast on 15 sts. T4. K. 8. T6. K. 1. T4. K. 8. M.D.E. with right edge of cuff facing band, place evenly onto NS and cast off to end. Repeat for left edge of cuff. Repeat for other cuff.

To Make Up

Press back and fronts. Join shoulders. Join bottom of side seams. Turn back hem and stitch.

Front Bands Jacket A

Cast on 82 (90, 98) sts. T4. K. 8. T6. K. 1. T4. K. 8. M.D.E. Place right front evenly onto NS working through both thicknesses of hem. Cast off to end repeat for left front.

Jacket B

In colour A cast on 60 (65, 70) sts. Make edge as above. Place right front (from hem to beg rib) evenly onto NS. Cast off to end. Repeat for left front. In colour B, cast on

24 (27, 30) sts. Make edge as above.

Buttonholes

From right edge cast off 4th-6th sts. * miss next 2 (3, 4) NS. Cast off next 3 sts. * repeat from * 3 more times, leaving 3 sts.

T4. K. 4 rows. T6. K. 1 row. T4. K. 4 rows.

Repeat buttonholes T4. K. 4. M.D.E.

Place right ribbed front onto NS and cast off to end. Repeat band omitting buttonholes for left edge.

Collar/Jacket A

Cast on 77 (83, 89) sts. as for 1 x 1 rib.

T2/2. K. 4 rows tubular T3/3. K. 34 rows with right side of work facing M/C. place front band to 4 sts., front neck to next 8 (9, 10) NS side neck to next 13 (14, 15) NS back neck to next 28 (30, 32) NS cast off to this point. Place rest of neck to remainder of NS in the same way. Cast off to end.

Jacket B As above K. 16 rows. Cast off as above.

Pockets/Jacket A Cast on 35 sts. as for 3 x 3 rib (see graph) in colour BT2/2. K. 4 rows Tubular T3/3. K. 49 rows of pattern cast off.

Pocket flap. Cast on 35 sts as above. K. 19 rows cast off.

Jacket B Cast on 35 sts as above K. 57 rows cast off.

Sleeves

Press sleeves and join cuffs onto sleeves. Sew tops of sleeves into armholes. Join rest of side seams and sleeve seams. Sew pockets $1\frac{1}{2}$ inches from front edge and level with bottom of hem. For Jacket A sew on flaps 4 inches up from hem.

Press all seams, bands and steam collar.

Jacket A

Sew in zip and stitch buttons onto pocket flaps, cuffs and collar.

Jacket B

Sew 4 buttons onto band to correspond with holes.

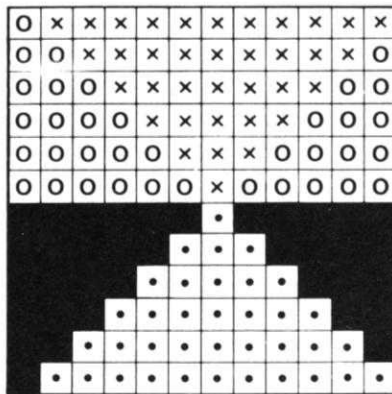

■ = colour A

x = colour B

• = colour C

O = colour D

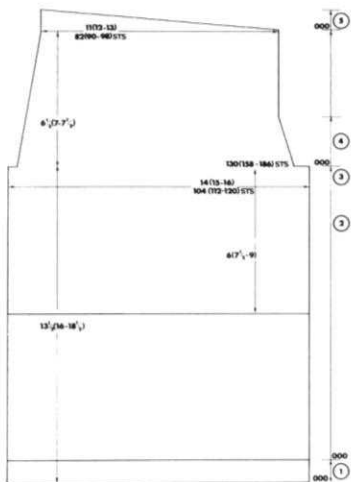

Trousers

- 1 C.O.B.H. 104 (112, 120) sts. T4. K. 12 T6. K. 1, T4. K. 12 M.D.E. T5. K. 1 row. C.O.R. 000.
- 2 K. 138 (166, 194) rows.
- 3 Cast off 5 sts. K. 1 row. Cast off 3 sts. K. 1 row 130 (158, 186) sts. C.O.R. 000.
- 4 On right edge dec. 1 st. every 4th row 7 times. At the same time on left edge, dec. 1st every 10 (11, 12) rows, 7 times K. to 72 (78, 84) rows.
- 5 Cast off 42 (45, 48) sts. K. 1 row col. * H.C.L.'s III (800 H.C.L. 1) push 8 (9, 10) Ns to E pos. K. 1 * row. Repeat four more times. H.C.L.'s I (800 H.C.L. 3) K. 1 row. Cast off to end.

Repeat for left leg, reversing all shapings.
Press legs join front crutch seam.

Waistband

C.O.B.H. 162 (178, 194) rows. T4. K. 12 T6. K. 1 T4. K. 12 M.D.E. Place top of trousers evenly onto Ns and cast off to end. Join back seam, inserting 1/2 inch elastic (to desired length) into waistband. Join inside leg seams.

Press all seams.

For Knickerbockers

- 1 Cast on 104 (112, 120) sts.
- 2 K. 68 (82, 98) rows.
- 3, 4 and 5 as for trousers.

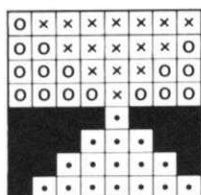

■ = colour A
x = colour B
• = colour C
o = colour D

588 Chart for jumper 'A'

Cuffs

In colour B cast on 103 (111, 119) sts. as for 3 x 3 rib (see graph). K. 44 rows M.D.E. Press legs. Join front crutch seam. Place leg edge evenly onto Ns and cast off to end. Repeat for other leg. Waistband and make up as above. Insert 1/2 inch elastic (to desired length) into knickerbockers cuffs.

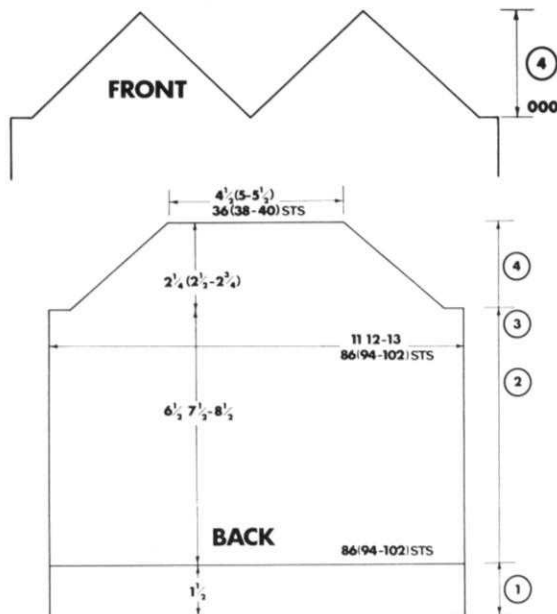

Jumper A

Back

- 1 Colour B. Cast on 87 (95, 103) sts. as for 1 x 1 T2/2 rows Tubular T3/3. 14 rows rib. Change to colour A. K. 4 rows rib. Dec. 1st. Trans. Ns to M.B. Set M.K. to Jacquard. C.O.R. 000.
- 2 T6. K. 66 (76, 86) rows Jacquard.
- 3 Cast off 3 (4, 5) sts. at beg next 2 rows to 80 (86, 92) sts. C.O.R. 000.
- 4 Dec. 1st at each end of every row 22 (24, 26) times to 36 (38, 40) sts. K. 1 row and thread up these sts. and take off m/c.

Jumper A

Front

1, 2 and 3 as for back.

- 4 Thread up sts. to left of centre 0 and take off m/c leaving 40 (43, 46) sts. on left edge. Dec. 1 st. at 000 and at beg. of every row 10 (12, 14) times and then every alt. row 12 times. At the same time shape armhole as for 4 back to end 22 (24, 26) rows. K. 1 row. place left sts. back onto m/c and repeat from 4, reversing all shapings.

Jumper B

Back

- 1 Rib in col. A as for Jumper A. Trans. Ns for 3 x 3 rib (see N.B.).

Tee Shirt and Trousers

Colour B

2 T3/3. K, 90 (104, 118) rows.

3 As for A.

4 Dec. 1 st. at beg. of every row 20 (24, 28) times then dec. 1 st. each end of every row 12 times to 36 (38, 40) sts. K. to 33 (37, 41) rows and thread up back neck sts. and take off.

Front

1, 2 and 3 as for back.

4 Thread up sts. to left of centre 0 and take off m/c leaving 40 (43, 46) sts. On left edge dec. 1 st. at beg. of every alt. row 17 (18, 19) times. At the same time shape armhole edge as for back. K. 1 row 37 (39, 41) rows. Place left sts. and put back onto m/c and repeat from **4** reversing all shapings.

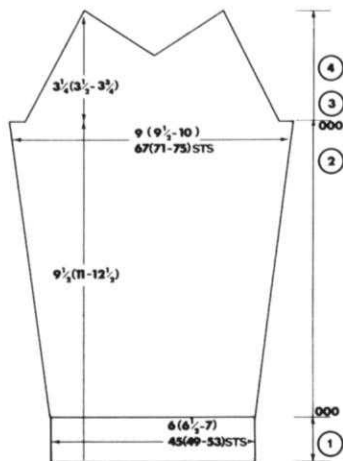

Sleeve

1 Rib. Cast on 45 (49, 53) sts. as for 1 x 1 rib T2/2. 4 rows tub. T3/3. 28 rows rib. Trans. Ns to M.B. C.O.R. 000.

2 Change col. T5. inc. 1 st. on each edge every 8 (9, 10) rows to 67 (71, 75) sts. K. to 88 (104, 120) rows.

3 Cast off 4 (5, 6) sts. at beg. next 2 rows to 59 (61, 63) sts. C.O.R. 000.

4 Dec. 1 st. on each edge every 3rd row 12 (13, 14) times. Row 20 (22, 24) push Ns to left of centre to E pos. H.C.L. III (800 H.C.L. 1) on inside edge dec. 1 st. at 000 and every row 16 times, con. dec. on outside edge K. to 36 (38, 40) rows. H.C.L. I (800 H.C.L. 3) repeat for left of sleeve dec. on both edges. Repeat sleeve. Press back front and sleeves. Join sleeves top to armholes of back and fronts.

Neckband

Cast on 137 (141, 145) sts. As for 1 x 1 rib. T2/2. 4 rows tub. T3/3. K. 30 rows. Trans. Ns to M.B. with right side of work facing m/c place side neck to first 23 (24, 25) sts., sleeve to 28 sts., back neck to 34 (36, 38) sts. and rest of sleeve and front neck to rem. of Ns. Cast off to end. Cross band and sew onto place. Join side and sleeve seams. Press all seams and neckband.



Materials

Of Lee Target Duo 4 ply Crepe Tricel and Nylon allow
 3 (3, 3) 20g balls Copper Bronze
 6 (6, 7) 20g balls Apricot
 3 small buttons for shirt
 Length of elastic for waist of trousers.

Actual Measurements

Shirt – Chest 20 (22, 24) ins.
 Sleeve seam $1\frac{3}{4}$ ($1\frac{3}{4}$, 2) ins.
 Back length 10 ($10\frac{3}{4}$, $11\frac{1}{2}$) ins.
 Trousers – Width of legs 10 (11, 12) ins.
 Waist 19 (21, 23) ins.
 Side length $8\frac{1}{2}$ ($9\frac{1}{4}$, 10) ins.

Tension

Over two colour work 8 sts. 9 rows T9. to 1 inch (unpressed).

Over st. st. 7 sts. 10 rows T8. to 1 inch (unpressed).

Abbreviations

st. stitch; inc. increase; dec. decrease; alt. alternate; beg. beginning; C.O.R. carriage on right; postn. position.

Trousers

Starting at lower edge, cast on over alt. needles 40 (44, 48) sts. with Copper Bronze. T8. and K. 6 rows. T10. K. 1 row for foldline. T8. K. 1 row. T9. Join in Apricot and knit (from chart) 10 (12, 14) rows, inc. 1 st. at beg. of every row. Knit one extra for 2nd side. With C.O.R. cast off 4 sts. at beginning of next row. Dec. 1 st. at both ends of next 4 alt. rows. Work $4\frac{1}{2}$ (5, $5\frac{1}{2}$) ins. without shaping, ending C.O.R. Putting all but last 20 (22, 24) sts. at right end of work onto nylon thread K. 2 rows on these sts. Bring next 20 (22, 24) sts. and work 2 rows on these 60 (66, 72) sts. With Copper Bronze only K. 1 row T8. Transfer every alt. st. to adjacent needle returning empty needles to postn A. K. 8 rows, T10. K. 1 row, T7. K. 8 rows. Cast off. Work second side to match reversing shapings. To make up – Press on wrong side, pinned out, with a slightly warm iron over a dry cloth. Join front and back body seams, then leg seam. Sew down waist hem leaving a small gap to thread elastic through.

Tee Shirt

Back – Cast on 74 (82, 90) sts. with Copper Bronze and work 2 rows K. 1. Pl. rib at T4. Change to Apricot and work 6 rows, then back to Copper Bronze and work 2 rows. Transfer sts. to main bed, and using Apricot only T8. and knit in st. st. until work measures $6\frac{1}{2}$ ($6\frac{1}{2}$, $6\frac{3}{4}$) ins. from cast on edge (adjust length here). Shape armholes. Cast off 3 sts. at beg. of next 2 rows. Dec. 1 st. at each

end of every alt. row 3 times. Work without further shaping until armhole measures $3\frac{1}{4}$ ($4\frac{1}{4}$, $4\frac{3}{4}$) ins. Shape shoulders. Cast off 7 (7, 8) sts. at beg. of next 4 rows and 6 (8, 8) sts. on next 2 rows. Cast off.

Front

Work as for back until armhole shaping are completed. With spare yarn cast off centre 6 (6, 6) sts. Front opening. Bring forward sts. at left side of work. H.C.L.'s 2. Working on right side of opening continue straight until armhole measures $2\frac{1}{4}$ ($2\frac{3}{4}$, $3\frac{1}{4}$) ins. ending at neck edge. Cast off 9 (10, 11) sts. at beg. of next row K. 1 row. Cast off 3 sts. at beg. (neck edge) of next row, then dec. 1 st. at this same edge until 20 (22, 24) sts. rem. Work straight until armhole measures same as back. Shape shoulder. With C.O.R. cast off 7 (7, 8) sts. at beg. of next and foll. 2 alt. rows, then 6 (8, 8) sts. on foll. alt. row. Return to left side of front. H.C.L.'s 3 and work to match other side reversing shapings.

Sleeves

With Copper Bronze yarn, cast on 54 (58, 62) sts. and work in with Copper Bronze. Transfer sts. to main bed and continue in Apricot only, T8. and st. st. inc. 1 st. at beg. of 1st and 2nd, 4th and 5th, and 7th and 8th rows. K. 2 (2, 4) rows straight, shape to top. Cast off 2 sts. at beg. of next 2 rows. Dec. 1st at both ends of next 16 (18, 20) rows. Cast off 3 sts. at beg. of next 4 (4, 6) rows. Cast off remaining sts.

Collar

With Copper Bronze yarn, cast on 96 (100, 104) sts. and working in K. 1 Pl. rib, T6. K. 2 rows, with Apricot, T5. K. 4 rows. With Copper Bronze K. 2 rows, with Apricot, T4. K. 6 rows. T3. K. 6 rows. Cast off.

Buttonhole Band

With right side of work facing machine, pick up 18 (18, 20) sts. along right front of front opening T7. with Copper Bronze, K. 3 rows, with Apricot K. 2 rows, then work 3 buttonholes in next row, evenly spaced. K. 2 more rows. With Copper Bronze K. 2 T10. K. 2 rows, make buttonholes as before, K. 4 rows. Cast off. For button band, work as for button band, using only Apricot and omitting buttonholes.

To Make Up

Pin out pieces and press on wrong side with a slightly warm iron over a dry cloth. Join all seams, neaten buttonholes and bands. Sew on collar to come just to the bands as shown. Press seams. Sew on buttons.

		=	↑	=	∨	O	O	O	O	O	O	O	2	2					B	→	/										
		↑	↓	B	∨	O	O	O	O	O	O	O	1	1	1	3	5	7	A	B	←	/									
CL	M.C.	PART	K.C.	L.Y.	S.L.	1	2	3	4	5	6	7	8	9	10	11	12	1	2	3	4	5	6	7	8	REVERSE KNOB LAYING IN YARN	K.C.	S.L.			
K.H.800 MACHINE												STEPS		STEPS		K.H.588 MACHINE												REVERSE KNOB LAYING IN YARN		K.C.	S.L.

Striped Jumper

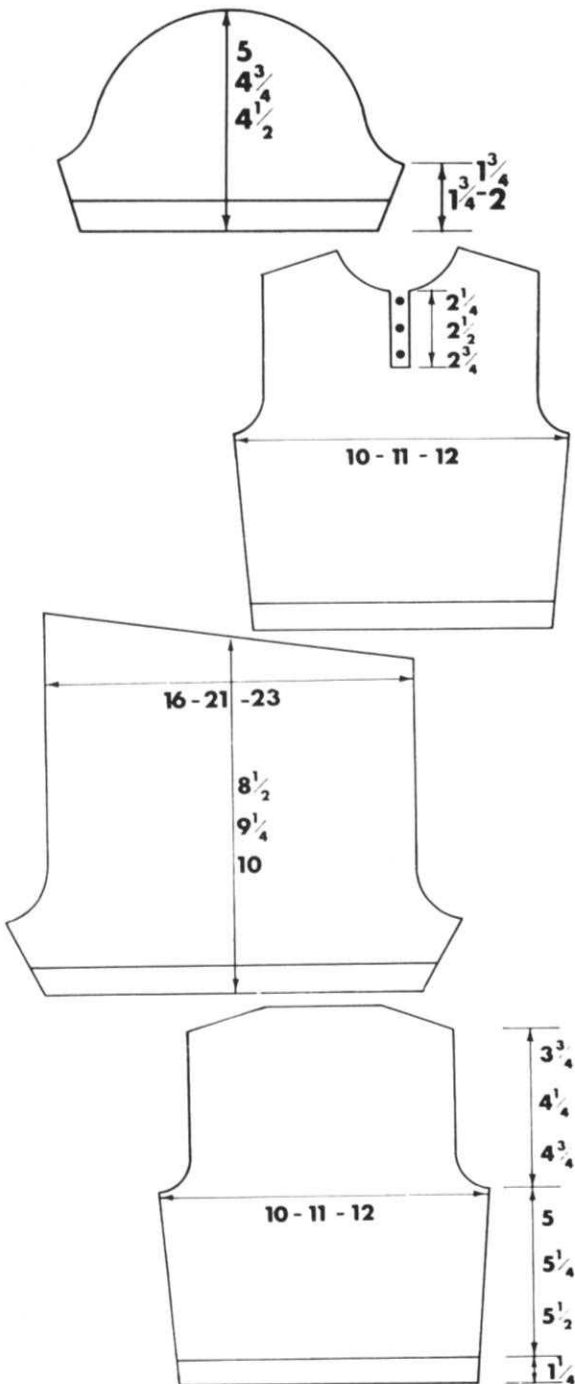

Materials

- 5 (6, 7) ozs. Sirdar Fontein Crepe 4 ply. Red
- 1 oz. each of Sirdar Fontein Crepe 4 ply. Purple, Orange, Green.
- 6 in. zip fastener.

Measurements

- To fit 24 (26, 28) in. chest
- Finished measurements 25 (27, 29) in.
- Length to back neck 14 (16, 18) in.
- Sleeve seam 11 (12, 14) in.

Tension

15 sts. and 20 rows = 2 ins.

Note

Back, sleeves and neckband in main col. with striped cable effect front.

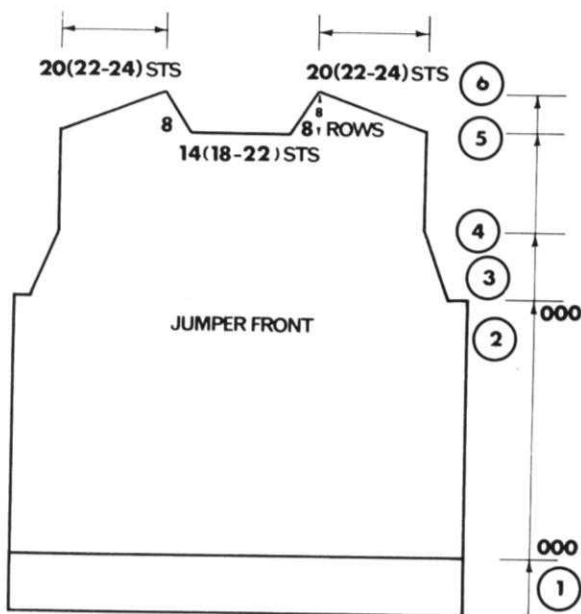

Back

- Hem** C.O.B.H. 90 (98, 106) sts. * T5. K. 20 rows. T7. K. 1 row for fold line. T5. K. 20 rows. C.O.L. M.D.E. T7. K. 1 row C.O.R. 000 **
- 76 rows straight (adjust length if desired at this stage).
- Cast off 2 (3, 4) sts. each end. Fin. 86 (92, 98) sts. C.O.R. 000.
- 22 rows Dec. 14 sts. 7 sts. on each edge. Dec. 1 st. each and every 3rd row. 000.
- Back opening divide work for each side at 4 (8, 12) rows.
- For back K. 24 (28, 32) rows.
- On shoulders cast off 4 groups of 5 sts. for each size then cast off 0 (2, 4) sts.
Thread up remaining 14 (16, 18) sts. on back neck. 000.

* At 000 set cable patt. as follows:

On right side of centre 0 transfer the 4th st. to the 3rd needle *Leave next 10 sts. then trans. the 11th st. to the 12th needle. Then trans. the 18th st. to the 17th needle. * Rep. from * to * twice more leaving rem. 5 (9, 13) sts. Push back to A pos. the empty needles. Work sts. of left of centre 0 to correspond. Work in following patt.

*K. 4 rows green, 4 rows orange, 4 rows purple, 4 rows red (16 rows).

To twist 6 st. cables and using 3 st. trans. tool, place left 3 sts. onto one trans. tool and place the right 3 sts. onto second trans. tool. and place this third st. onto the left 3 empty needles, then place the left 3 sts. onto the right 3 empty needles. Work other cables to correspond *. Repeat from * to *.

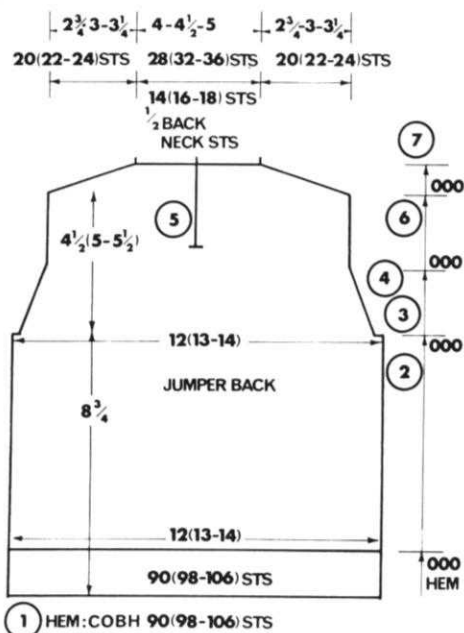

Front

- Hem** repeat as for back from * to **.
- * 76 rows straight (adjust length at this stage if required).
- Cast off 2 (3, 4) sts. each end. Fin. C.O.R. 86 (92, 98) sts.
- 22 rows Dec. 14 sts. 7 sts. each edge. Dec. 1 st. each end every 3rd row.
- For front K. 24 (28, 32) rows. Thread up and take off m/c the centre 14 (18, 22) sts.
- 10 rows of shoulder shaping as for back. Also dec. 1 st. on neck edge every row for 8 rows.

Toddler's Outfit

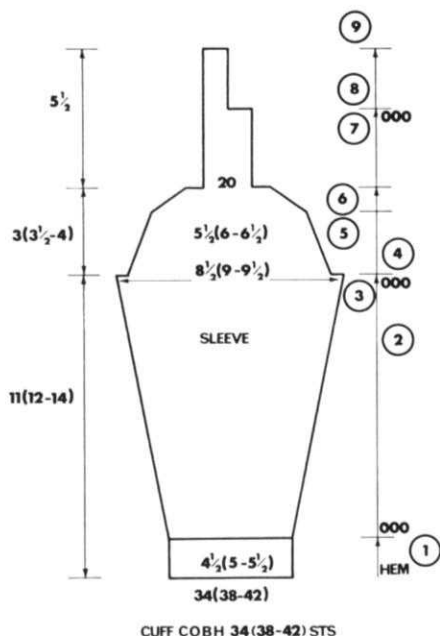

Sleeve

Cuff C.O.B.H. 34 (38, 42) sts.

- Hem** Repeat as for back from * to **.
- Inc. 1 st. each end of every 6th row to row 90. (adjust length here if required).
- K. to 102 (106, 110) rows.
- Cast off 2 (3, 4) sts. each end. Fin. C.O.R. 64 (68, 72) sts.
- Dec. 16 sts. 8 sts. each end. Dec. 1 st. each end every 3rd row. 26 rows.
- Dec. 20 sts. 10 sts. each side. Dec. 1 st. each end every 2nd row. 10 rows.
- 32 rows straight.
- Cast off 10 sts.
- 22 rows straight. Cast off rem. 10 sts.

Making Up Information

Neckband

C.O.B.H. 82 (86, 90) sts. T5. K. 10 rows. T7. K. 1 row for foldline. T5. K. 18 rows. M.D.E.

Press back, front and sleeves. Sew the tops of sleeves into armhole and the saddle strap onto the back and front of the jumper. With right side of work facing the machine and working from right edge of needles, place the right half back neck to first 14 (16, 18) needles, front side neck to next 16 (18, 20) needles. Cast off band and neck edge together to this point, place the rem. of neck to rest of needles and cast off band and neck tog. to end.

Join side seams and sleeve seams. With No. 9 crochet hook, crochet round back opening at same time working through both layers of neckband. Sew in zip. Press opening and seams. Press neckband into curve to fit neck.



Materials

Jumper: 3 (3, 4) ozs. Col. A. Robin courtelle crepe in 4 ply. 1 oz. Col. B. and 1 oz. Col. C. in Robin courtelle crepe in 4 ply.

Trousers: 4 (4, 5) ozs. Col. A, small ball of B and C in Robin courtelle crepe in 4 ply.

3 small buttons.
 $\frac{3}{4}$ in. wide elastic.

Tension

7 sts. and 10 rows equals 1 in. on T7.

Measurements

To fit 18 (20, 22) in. chest.
 Finished measurements 19 (21, 23) in.

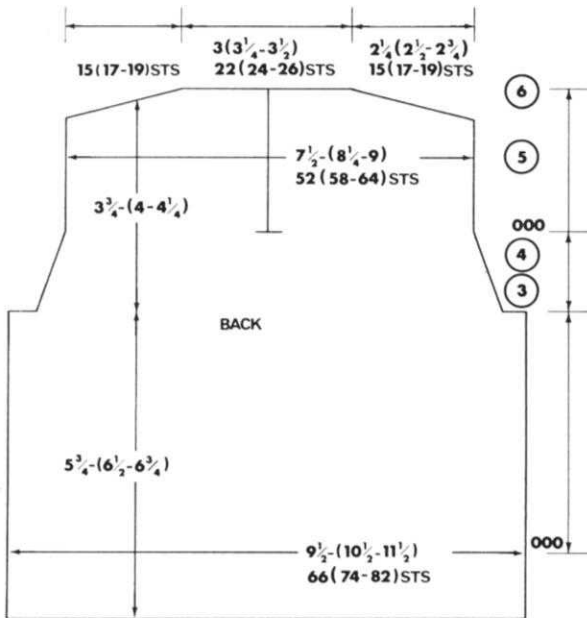

Back

- C.O.B.H. 66 (74, 82) sts. Col. C. T5. K. 9 rows. Col. C. T8. K. 1 row. Col. C. T5. K. 3 rows. Col. B. T5. K. 3 rows. Col. C. T5. K. 3 rows. M.D.E. T8. K. 1 row. Col. A. C.O.R. 000.
- * 8 (10, 12) rows Col. A, 2 rows Col. B, 2 rows Col. C and 2 rows Col. B *. Repeat * to * to 50 rows. 000.
- Cast off 3 (4, 5) sts. at beg. of next 2 rows to 60 (66, 72) sts. C.O.R. 000.
- Dec. 1 st. at each end of every 4th row, 4 times to 52 (58, 64) sts. (16 rows), C.O.R. 000. Thread up and take off work to left of centre at 000.
- 22 (24, 26) rows straight to shoulder.
- Shoulder:** Cast off 5 sts. at beg. of next 4 rows. Then cast off 5 (7, 9) sts. at beg. of next 2 rows. Thread up remaining 22 (24, 26) back neck sts.

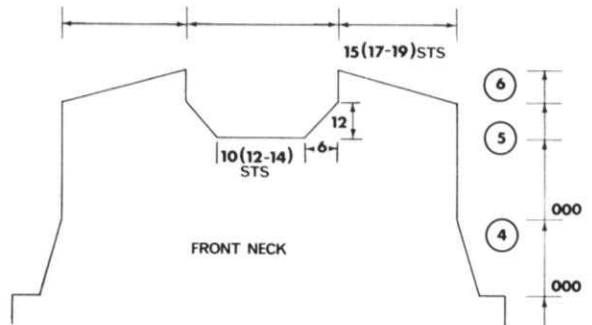

Front

Same as back to 3.

4 Shaping as for back 000 start jacquard after armhole shaping.

5 K. to row 10 (12, 14). Thread up centre 10 (12, 14) front neck sts. At neck edge dec. 1 st. every alt. row 6 times to 15 (17, 19) sts.

6 Shoulder as for back.

Neckband

In Col. C, C.O.B.H. 64 (70, 76) sts. T5. K. 6 rows. T8. K. 1 row. T5. K. 2 rows. Col. B. K. 2 rows. Col. C. K. 2 rows. M.D.E.

Press backs and fronts, join shoulder seams, with right side of work facing machine and working from left to right, place $\frac{1}{2}$ back neck to first 11 (12, 13) sts. side front neck to next 16 (17, 18) sts. and front back to 10 (12, 14) sts. Cast off to this point. Place rest of neck to remainder of needles.

Back Neck Bands (Knit 2)

Col. C. C.O.B.H. 20 (22, 24) sts. As for neck band. Hang back opening evenly onto needles and cast off. Repeat.

O	O	O	O					O	O	O	O
O	O	O	O					O	O	O	O
O	O	O	O					O	O	O	O
O	O	O	O					O	O	O	O
		x	x	x	x	x	x	x	x		
		x	x	x	x	x	x	x	x		
		x	x	x	x	x	x	x	x		
		x	x	x	x	x	x	x	x		

□ = colour A
 x = colour B
 O = colour C

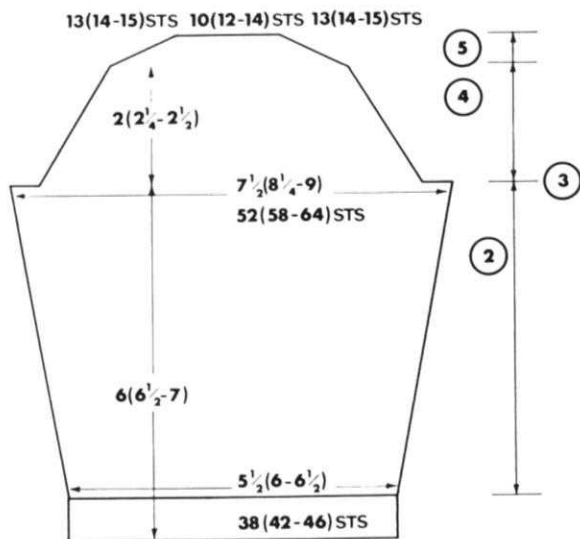

Sleeves

- In Col. C. C.O.B.H. 38 (42, 46) sts. Continue as for back hem.
- 60 (64, 68) rows. Inc. 1 st. each end of every 8 (7, 7) row 7 (8, 9) times to 52 (58, 64) sts. K. to row 60 (64, 68).
- Cast off 3 (4, 5) sts. at beg. of next 2 rows to 46 (50, 54) sts.
- 20 (22, 24) rows. Dec. 1 st. each end of every 4th row 5 times to 36 (40, 44) sts.
- Cast off 3 sts. at beg. of every row for 8 rows, then dec. 1 (2, 3) sts. at beg. of next 2 rows. Cast off remaining 10 (12, 14) sts.

○	○	○				○	○
○	○	○				○	○
○	○	○				○	○
○	○	○				○	○
		x	x	x	x	x	
		x	x	x	x	x	
		x	x	x	x	x	
		x	x	x	x	x	

- = colour A
 x = colour B
 ○ = colour C

To Make Up

Press sleeves and sew tops into armholes. Join side and sleeve seams and press all seams. Press neck band into curve to fit neck, press back opening.

Rouleau

Cast on 2 sts. T3. K. approx. 5 in. Sew 3 buttons onto right back band. Thread rouleau through left band, making 3 loops to correspond with buttons.

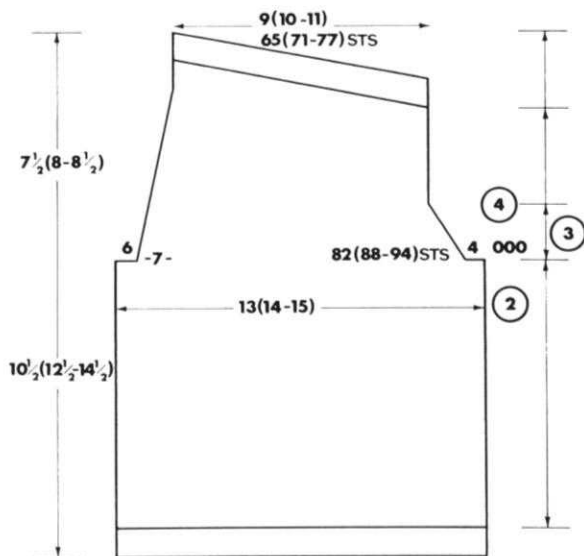

Left Trouser Leg (Reverse all shapings for right leg)

Hem 1: in Col. C. C.O.B.H. 92 (98, 104) sts. Continue as for back.

2 98 (118, 138) rows straight. Start jacquard at 000. Fin. row 32.

3 000. Cast off 4 sts. on this edge. K. 1 row. Cast off 6 sts. at this edge. K. 1 row. C.O.R. 000.

4 On opposite edge dec. 1 st. every 8th row 7 times to 65 (71, 77) sts. at the same time dec. 1 st. at beg. of every alt. row on this edge only. 10 times (56 rows).

5 K. 1 row. C.O.L.

6 Push 45 (47, 49) Ns. at opp. end to carriage to D. pos. H.C.L. III (800 H.C.L. 1). K. 2, push 5 (6, 7) Ns. at opp. end to carr. to D. pos. every alt. row 4 times. C.O.L. H.C.L. I (800 H.C.L. 3). K. 1. For waist band see below.

Waist Band (After shaping)

T5. K. 12. T8. K. 1. T5. K. 12. M.D.E. cast off.

To Make Up

Press both legs. Join crutch seams, inserting $\frac{3}{4}$ in. elastic (to desired length) into waist band. Join inside leg seams. Press all seams.

Fairisle Sweater



Materials

2 (2, 3, 3) ozs. dark green (Laurel)
3 (3, 4, 4) ozs. light grey (Frost Grey)
1 (1, 1, 1) oz. bright red (Scarlet)
all 3 ply crepe wool obtainable post free from Albert Bailey & Sons Ltd, Riverside Mill, Elland, Yorks. HX5 9DR.

Measurements

Chest: 22 (24, 26, 28) ins.
Sleeve seam: $8\frac{1}{2}$ ($10\frac{1}{2}$, 12, 13) ins.
Length from back of neck: $12\frac{1}{2}$ (13, $13\frac{3}{4}$, $14\frac{1}{2}$) ins.

Tension

(Over st. st. when pressed) 7 sts. 10 rows at T8.

Note

Mock rib may be used successfully in place of proper rib.

Back

With green wool, cast on 82 (88, 96, 102) sts. T4. and knit. K. 1 Pl. rib for 10 (10, 12, 12) rows. Trans. sts. from front bed to M.B. T8. with grey wool K. 4 (4, 6, 6) rows. T9. using red as contrast, work from chart A; when completed break off red and using grey only T8. and work for $3\frac{1}{2}$ (4, $4\frac{1}{2}$, 5) ins. (adjust length here). T9. Using green as contrast, work through chart B. T8. Using grey only shape armholes by casting off 2 (2, 4, 4) sts. at beg. of next 2 rows. T9. Working from chart C and using red as contrast, dec. 1 st. at beg. of every row. When chart C is completed, K. 2 rows in green then using grey as contrast and green as background, work from chart D, dec. 1 st. at beg. of every row as before to 34 (36, 36, 38) sts. K. 1 row in green. Put on waste.

Front

Work as for back until 24 (28, 32, 36) rows from chart D have been knitted. Put centre 12 (14, 14, 16) sts. on thread or waste and left hand set of sts. on a holder and continue on right hand set. Dec. 1 st. at raglan edge as before on every alt. row AT THE SAME TIME dec. 1 st. at neck edge of next 2 rows, then 1 st. at neck edge of every alt. row until all sts. are worked off. Work other side of neck to match.

Sleeves

With green wool, cast on 46 (48, 52, 56) sts. T4. and work in K. 1 Pl. rib for 12 rows (all sizes). Trans. sts. from front bed to M.B. T8. with grey K. 4 (4, 6, 6) rows plain. T9. using red as contrast work through chart A. AT THE SAME TIME inc. 1 st. at both ends of every 6th (6th, 8th, 8th) row to 60 (68, 76, 82) sts. When chart A has been completed, change to T8, and continue in st. st. in grey wool for $3\frac{1}{2}$ ($5\frac{1}{2}$, 7, $8\frac{1}{2}$) ins. (adjust length here). T9. Working from chart B, and using green as contrast. T8. using grey, shape raglan by casting off 2 sts. at beg. of next rows. T9. using red as contrast, work from chart C, dec. 1 st. at beg. of every row (as on back). When chart C is completed, K. 2 rows green then using grey as contrast and green as background, work from chart D still shaping raglan as before until 12 (14, 16, 18) sts. remain. Put on waste.

Neckband

Join raglan seams, leaving one back seam open. Pin out to size and press on wrong side with a hot iron over a damp cloth. When cool and dry, rehang work onto machine (with wrong side towards you) from back neck 34 (36, 36, 38) sts. sleeve top 12 (14, 16, 18) sts. from side neck pick up 10 (10, 11, 11) sts. centre front neck 12 (14, 14, 16) sts. side neck 10 (10, 11, 11) sts. second sleeve top 12 (14, 16, 18) sts. making a total of 90 (98, 104, 112) sts. With green wool, T7. K. 1 row, T6. K. 2 rows. T5. K. 4 rows. T10. K. 1 row. T4. K. 3 rows. T5. K. 4 rows. T6. K. 1 row (16 rows). Cast off loosely. To make up. Sew neckband down neatly on wrong side (to form a double band). Join remaining raglan seam, sleeve and side seams. Give seams a press.

D	" /	•											42	42		•			•	" →				
	" /	•											41	41		•			•	" →				
	" /	•	•	•				•	•	•			40	40	•	•	•		•	•	" →			
	" /	•	•	•				•	•	•			39	39	•	•	•		•	•	" →			
	" /	•											38	38		•					" →			
	" /	•											37	37		•					" →			
	" /	•											36	36	•				•		" →			
	" /												35	35	•				•		" →			
	" /												34	34	•	•			•	•	" →			
	" /												33	33	•	•			•	•	" →			
	" /												32	32	•				•		" →			
	C	" /											31	31	•				•		" →			
C	" /	•	•	•	•	•	•	•	•	•	•	•	30	30	•	•	•	•	•	•	" →			
	" /	•	•	•	•	•	•	•	•	•	•	•	29	29	•	•			•	•	" →			
	" /												28	28	•				•		" →			
	" /												27	27	•	•			•		" →			
	A	" /											26	26	•						" →			
B	" /	•											24	24					•		" →			
	" /	•	•	•									23	23					•	•	" →			
	" /	•	•	•									22	22					•	•	" →			
	" /	•											21	21					•		" →			
	" /	•											20	20					•		" →			
	" /	•	•										19	19					•	•	" →			
	" /	•											18	18					•		" →			
	" /	•											17	17					•		" →			
	" /	•	•	•	•	•	•	•	•	•	•	•	16	16					•	•	" →			
	" /												15	15					•		" →			
	" /												14	14					•		" →			
	" /												13	13					•		" →			
" /	•	•	•	•	•	•	•	•	•	•	•	12	12					•	•	" →				
" /	•											11	11					•		" →				
" /	•	•										10	10					•		" →				
" /	•	•										9	9					•	•	" →				
" /	•	•										8	8					•	•	" →				
B	" /	•										7	7					•		" →				
A	" /	•										6	6	•				•		" →				
	" /	•										5	5	•				•		" →				
	" /	•	•									4	4	•	•			•	•	" →				
	" /	•	•									3	3	•	•			•	•	" →				
	A	" /	•									2	2	•				•		" →				
" /	•										1	1	•				•		" →					
K.C.		1	2	3	4	5	6	7	8	9	10	11	12	STEPS	1	2	3	4	5	6	7	8	LY.	K.C.
K.H. 800 MACHINE												STEPS		K.H. 588 MACHINE										

Jumper and Smock Top



Materials

Jumper 5 (6, 7) ozs. Robin Tricel Perle. Neon Pink.
 Smock 4 (5, 6) ozs. Robin Tricel Perle. Neon Pink.
 1 oz. Robin Tricel Perle. Banana Whip.
 2 oz. Robin Tricel Perle. New Bronze.
 4 in. zip fastener.

Measurements

To fit 22 (24, 26) in. chest.
 Finished measurements 23 (25, 27) ins.
 length to back neck 13 (15, 17) ins.
 Sleeve seam 10 (11, 12) ins.

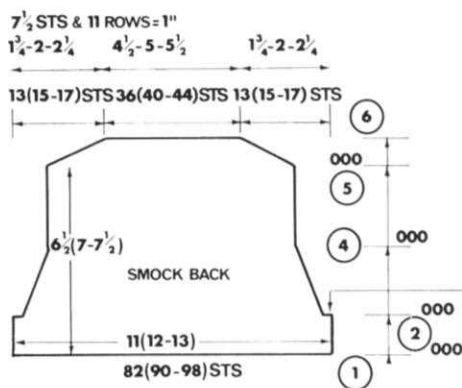

Smock Back

- 1 Bring out 82 (90, 98) sts. and K. some scrap yarn then beg. patt. at 000.
- 2 K. 16 rows straight.
- 3 Cast off 2 (3, 4) sts. at each end. Fin. C.O.R. 000.
- 4 28 rows. Dec. 14 sts. 7 sts. on each edge. Dec. 1 st. each end every 4th row.
- 5 K. 28 (30, 32) rows.
- 6 On shoulders cast off 4 groups of 3 sts. for each size. Then cast off 1 (3, 5) sts. Cast off rem. 36 (40, 44) sts.

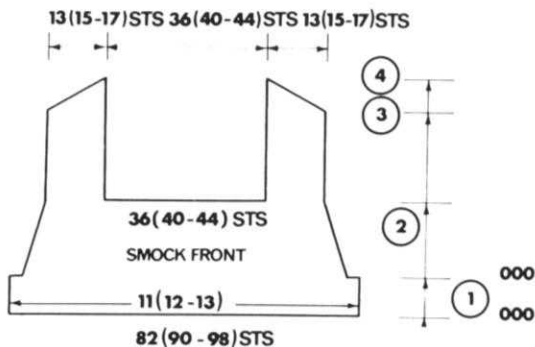

Smock Front

- 1 Same as back to 2.
- 2 28 rows. Dec. 14 sts. 7 sts. on each edge. Dec. 1 st. each end every 4th row. Cast off centre 36 (40, 44) sts.
- 3 K. 28 (30, 32) rows.
- 4 On shoulders, cast off 4 groups of 3 sts. for each size. Then cast off 1 (3, 5) sts.

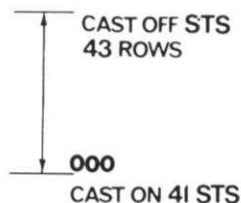

Pocket

Cast on 41 sts. K. 43 rows. Cast off.

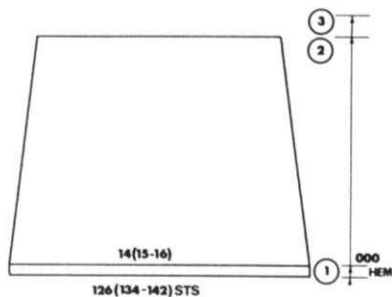

Skirt

- 1 Hem. C.O.B.H. 126 (134, 142) sts.
- 2 114 (116, 120) rows. Dec. 22 sts. 11 sts. each side Dec. 1 st. each end every 10th row (adjust length at this stage if desired).
- 3 Thread up 108 (112, 116) sts.

Place the smock back on the m/c and then place on skirt part placing 2 sts. on every 4th needle. Leave 1 st. at each end. Then count every 4th needle. Cast off.

Edgings

Crochet armhole edges and neck edge three times round. Also crochet pocket edgings.

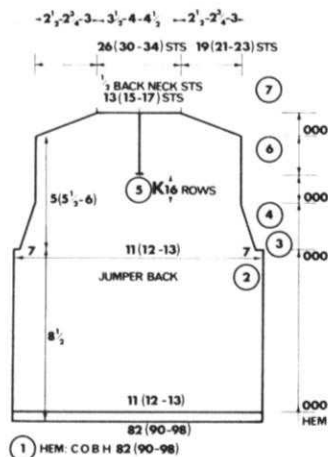

Jumper Back

- 1 Hem C.O.B.H. 82 (90, 98) sts. + T4. K. 6 rows. Trans. every alt. N. T4. K. 6 rows. M.D.E. T6. C.O.R.
- 2 88 rows straight (adjust length at this stage if desired).
- 3 Cast off 1 (2, 3) sts. each end. Fin. C.O.R. 80 (86, 92) sts.
- 4 22 rows. Dec. 14 sts. 7 sts. each end. Dec. 1 st. each end of every 3rd row.
- 5 K. 16 rows. Divide for back opening. Work one side at a time.
- 6 20 rows straight.
- 7 On shoulders cast off 3 groups of 6 sts. for each size. Then cast off rem. 1 (3, 5) sts. Thread up rem. 13 (15, 17) sts.

STEPS	1	2	3	4	5	6	7	8	COLOR
54									A
53									A
52				x	x	x			A
51				x	x	x			A
50				x	x	x			A
49				x	x	x			A
48									A
47									A
46			x	x	x				A
45			x	x	x				A
44			x	x	x				A
43			x	x	x				A
42									A
41									A
40									B
39									B
38									B
37									B
36									B
35									B
34			x	x	x				B
33			x	x	x				B
32			x	x	x				B
31			x	x	x				B
30									B
29									B
28									B
27									B
26									B
25									B
24									B
23									B
22									A
21									A
20									A
19									A
18									A
17									A
16									A
15									A
14									A
13									A
12									A
11									A
10									A
9									A
8									A
7									A
6									A
5									A
4									A
3									A
2									A
1									A

Repeat from row 19

x = laying across yarn
 □ = press buttons
 ■ (see note)

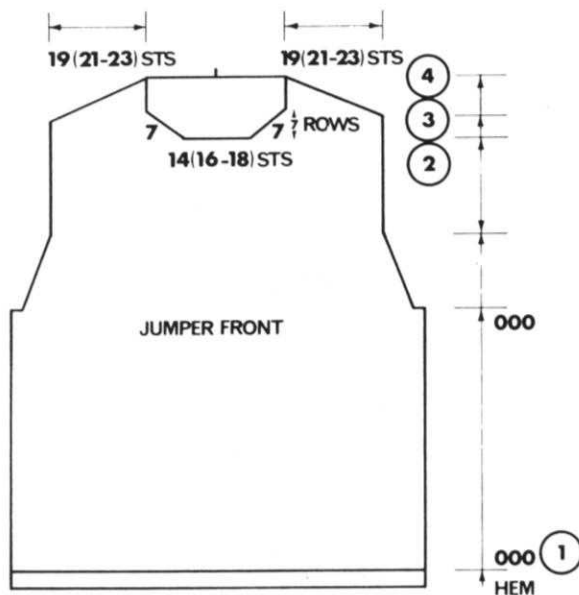

Jumper Front

- 1 Hem** Repeat as for back to 2.
- 2** For front K. 27 (31, 35) rows. Thread up and take off m/c the centre 14 (16, 18) sts.
- 3** 7 rows. Dec. 7 sts. on neck edge 1 st. every row.
- 4** Shoulder shaping as for back.

Neckband

C.O.B.H. 66 (70, 74) sts. T4. K. 6 rows. Trans. every alt. needle T4. K. 6 rows. M.D.E.

To Make Up

Neckband (Jumper)

C.O.B.H. 66 (70, 74) sts. T4. K. 6 rows. Select nos. 1, 3, 5, 7. Take lace carriage from left to right. T4. K. 6 rows. M.D.E. Press back, front and sleeves. Sew the tops of sleeves into armhole. With right side of work facing m/c and working from right edge of needles, place the right half back neck to first 13 (15, 17) needles, front side neck to next 10 (12, 14) needles. Cast off band and neck edge together to this point, place the rem. of neck to rest of needles and cast off band and neck tog. to end. Join side seams and sleeve seams. With no. 9 crochet hook, crochet around back opening. At same time working through both layers of neckband. Sew in zip. Press opening and seams. Press neckband into curve to fit neck.

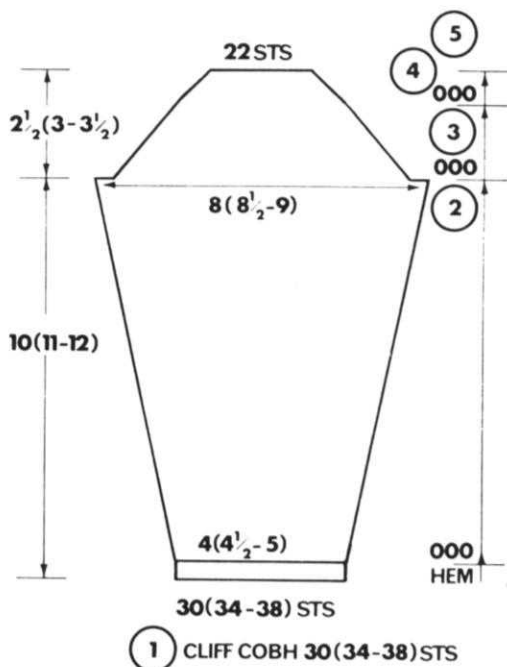

Sleeve

- 1 Cuff.** C.O.B.H. 30 (34, 38) sts. as hem.
- 2** 112 (116, 120) rows. inc. 26 sts. 13 sts. on each edge. Inc. 1 st. each end and every 8th row. 100 (104, 108) rows. K. up to 112 (116, 120) rows.
- 3** 22 rows. Dec. 14 sts. 7 sts. each edge. Dec. 1 st. each end every 3rd row. Cast off 1 (2, 3) sts. each end. Fin. C.O.R. 000.
- 4** 10 rows. Dec. 20 sts. 10 sts. each side. Dec. 1 st. each end every alt. row.
- 5** Cast off rem. 22 sts.

Neckband (Smock)

With no. 9 crochet hook, crochet round neck and armholes 3 times in all.

Press back and front bodices and skirt pieces. Then place smock back onto the machine and then place on skirt part placing 2 sts. on every 4th needle. Leave 1 st. at each end, then count every 4th and place on 2 sts. Cast off. Repeat for front. Join side seams and shoulder seams. Final press. Attach pockets where required.

Note:

On jacq. patt. at row 19, A is the main col, place and lay across yarn at 2, 3, 4 for 4 rows. Then B becomes main colour. Press buttons until row 41 then back to col. A.

- A — Brown
- B — Yellow
- C — Pink

Dress and Sleeveless Waistcoat



Materials

7 (7, 8, 9) 20 gm balls of Listers 2 spun 4 ply Nylon and Tricel Crepe, in main colour.

4 (4, 5, 6) 20 gm balls of Listers 2 spun 4 ply Nylon and Tricel Crepe in contrast colour. One No. 10 crochet hook. 2 buttons for dress. 2 buttons for waistcoat.

Measurements

Chest 20 (22, 24, 26) in. actual measurements.

Sleeve length 7 ($8\frac{1}{2}$, $10\frac{1}{2}$, 12) in.

Dress length from neck to hem 15 (16, 17, 18) in.

Waistcoat length from back neck to lower edge 10 ($10\frac{1}{2}$, $11\frac{1}{2}$, $12\frac{1}{2}$) in.

Tension

T8. 14 sts. and 19 rows equals 2 in. when pressed.

Abbreviations

St., stitch, dec., decrease, inc., increase, R.C., row counter, 000, set row counter to 000. H.C.L., holding cam lever, alt., alternate, rem., remaining beg., beginning, pos., position, foll., following.

Dress

Back - With contrast yarn, cast on 105 (112, 119, 126) sts., T6. K. 8 rows. T10. K. 1 row for foldline. T7. K. 8 rows make hem. T8. K. 1 row. 000. T10. Thread up with main colour and using contrast as laying yarn, work from chart to R.C. 13. Break off contrast T8. Working with main colour only dec. 1 st. at both ends of every 4th row until 74 (80, 88, 96) sts. rem. Work without further shaping to R.C. 108 (114, 128, 142) adjust length here if required.

Shape armholes

000. Cast off 5 (5, 7, 8) sts. at the beg. of next 2 rows, then dec. 1 st. at both ends of next 3 alt. rows 58 (64, 68, 74) sts. Work straight to R.C. 18 (20, 24, 26).

Shape neck

With spare yarn, cast off the centre 16 (18, 18, 20) sts. Put sts. at left side of neck into pos. E H.C.L. on 2. Decrease 1 st at neck edge on next 7 rows 14 (16, 18, 20) sts. Work straight to R.C. 32 (36, 42, 46).

Shape shoulder

Cast off 7 (8, 9, 10) sts. at beg. of next and foll. alt. row. Work other side to match.

Back

Work as for front till armhole shapings are completed. Divide for back opening. Put 29 (32, 34, 38) sts. at left side of work into E pos. H.C.L. on 2 and work to R.C. 32 (36, 42, 46).

Shape shoulder by casting off 7 (8, 9, 10) sts. at beg. of next and foll. alt. row. Cast off rem. sts. Work other side to match.

Sleeve

With contrast yarn, cast on 42 (46, 50, 54) sts. T6. K. 6 rows. T10. K. 1 row for foldline. T7. K. 6 rows. Make hem. K. 1 row. 000. T10. and work from chart to R.C. 13. Break off contrast yarn. Continuing in main colour only inc. 1 st. at beg. of every 7th and 8th row to 52 (56, 60, 64) sts. Work without further shaping to R.C. 66 (80, 100, 114) or length required.

Shape Top

Cast off 5 (5, 6, 7) sts. at beg. of next 2 rows. Dec. 1 st.

at both ends of every alt. row to 20 sts. (all sizes). Cast off.

Sleeveless Waistcoat

Back – With contrast yarn, cast on 76 (82, 90, 98) sts. T6. K. 6 rows. T10. K. 1 row for foldline. T7. and K. 6 rows. Make hem. K. 1 row. 000. T10. Using main colour as laying in yarn, this time work throughout from chart as follows:

Work to R.C. 32 (36, 40, 48).

Shape Armholes

Cast off 6 (6, 8, 9) sts. at beg. of next 2 rows dec. 1 st. at both ends of next 7 alt. rows. 50 (56, 60, 66) sts. Work without further shaping to R.C. 96 (100, 110, 120). Cast off 5 (6, 6, 7) sts. at beg. of next 4 rows. Cast off.

Right Front

With contrast yarn, cast on 38 (42, 46, 50) sts. and work as for back to armhole shapings. R.C. 32 (36, 40, 48). Cast off 6 (6, 8, 9) sts. at beg. of next row. K. 1 row. Dec. 1 st at beg. of next and foll. alt. row to 25 (29, 31, 34) sts. K. 3 (3, 5, 5) rows.

Shape Neck

Cast off (at left edge) 9 (11, 13, 14) sts. K. 1 row. Dec. 1 st. at neck edge of every alt. row to 10 (12, 12, 14) sts. Work without further shaping to R.C. 96 (100, 110, 120).

Shape Shoulders by casting off 5 (6, 6, 7) sts. at beg. of next and follow. alt. row. Work other side to match, reversing shapings.

Banding

Join shoulder seams. With wrong side of work facing

towards you, pick up along armhole edges and hang onto machine. 68 (76, 82, 90) sts. With contrast yarn T7., K. 6 rows. T10. K. 1 row for foldline. T6. K. 6 rows. Cast off. Work other armband to match.

Neckband

With wrong side of work facing and using contrast yarn, pick up 26 (30, 34, 40) sts. along neck edge of front 24 (28, 32, 38) sts. across back neck and 26 (30, 34, 40) sts. along rem. neck edge. Work banding as on armholes.

Front Bands

With wrong side facing as before, pick up 40 (42, 48, 52) sts. along front edge (including edging to foldline) and work as for armband. Work 2nd front band the same.

To Make Up

Pin out all pieces to size and press.

Dress

Join shoulder, side and sleeve seams. Press seams. Set in sleeve. Work 1 row of double crochet round back opening with main yarn, making 2 loops for fastening at same time. Using contrast colour, work 1 row of double crochet around neck edge. Give a final press and sew on buttons.

Waistcoat

Sew down banding and neaten. Press while flat. Join side seams, press them. With contrast yarn make a loop at top edge of front banding, long enough to just go over button. Sew on one button at top of each band at neckline.

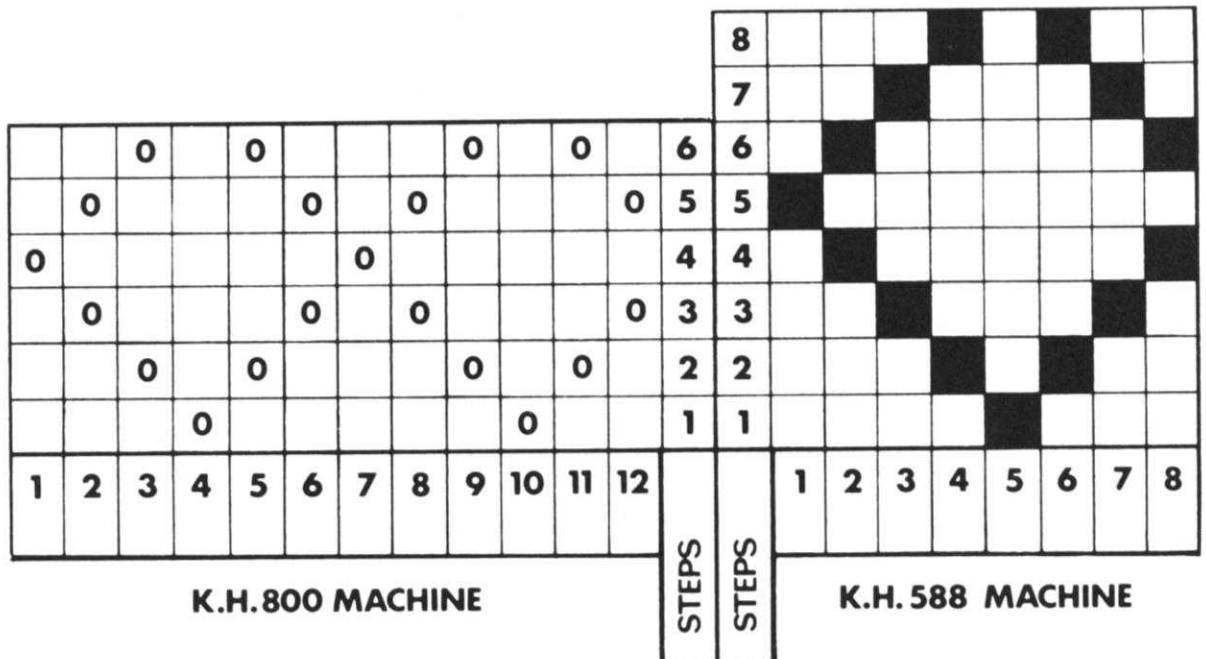

1
8

Jones

the knitting machine people

Jones Sewing Machine Co. Ltd.
BRITANNIA HOUSE,
964 HIGH ROAD, FINCHLEY, LONDON, N.12

Mc/2500/174/3/L