

KNITTING TECHNIQUES BOOK



brother®

KNITTING TECHNIQUES BOOK

CONTENTS



Casting-on	2
Finished Cast-on Edge	7
Cast-off Edge	22
Taking off the Stitches (Swatch)	30
Picking up Stitches	31
Increasing	34
Decreasing	36
Example of Decreasing	40
Partial Knitting	44
Binding off the Stitches	49
Seaming	54
Sewing	60
Knitting Stitches	67
Knitting the Ends of Yarn	70
Putting in a Yarn Mark (Reference Mark) on the Swatch	71
How to Adjust a Tension Gauge	72
Cord Knitting	76
Buttonhole	79
Finishing	85
Pompon / Tassel	101
Embroidery	103
Picture Knitting	106
Volume Knitting	109
Copy Knitting	111
Motif Knitting	114
Knitting Motifs without Seams	117
Reversible Knitting	121
Shirring	124
Scallop	127
Smocking	129
Bobbles	132
Braid	134
Pleated Skirt	136
Shadow Knitting	141
Cut and Sew	144
Knitting Symbols	145

1 Casting-on

Casting-on with the cast-on comb (Open edge)

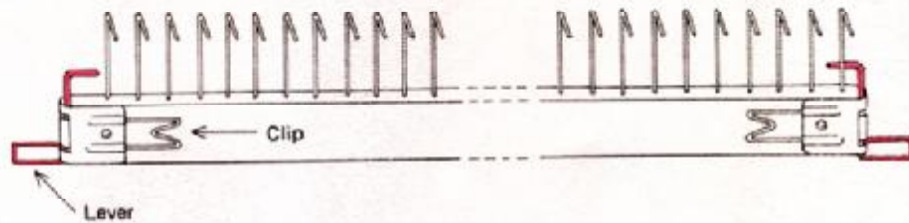

- ① Bring forward all the required needles to position 'B' and place the K carriage on either side of the machine.

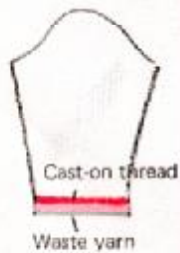
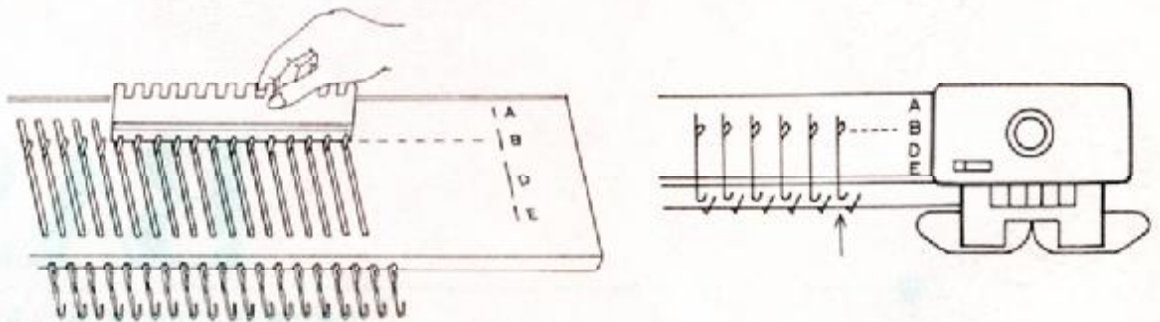

- ② Hold the cast-on comb, with the clip facing you, and turn the levers at both sides towards you.

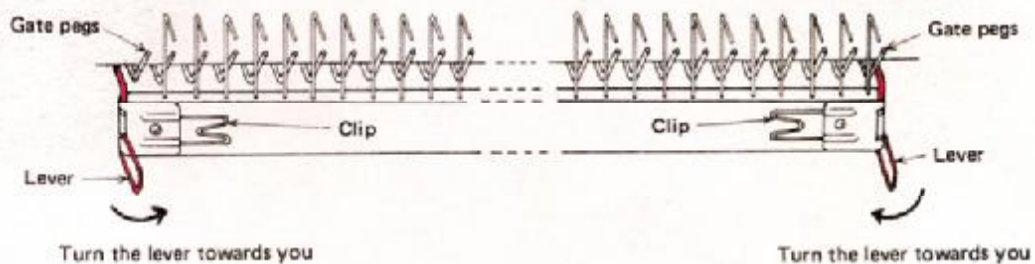

- ③ Place the hooks of the cast-on comb onto both end gate pegs and turn the levers at both sides towards the machine.

(When using the small cast-on comb place this on the 50th gate peg either side of '0').
 * Make sure that the cast-on comb is set on both end gate pegs correctly and is balanced.

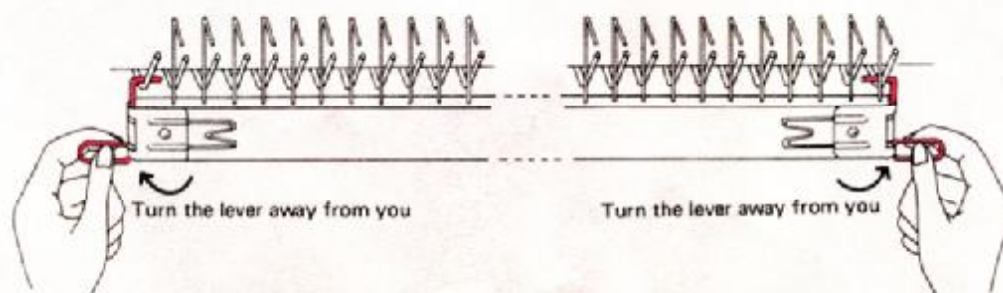

- ④ Place the K carriage at the right hand side of the machine. Thread the yarn into yarn feeder 'A' and hold the end of it with your hand under yarn feeder 'A'. Move the K carriage to the opposite side of the machine. Holding the end of the yarn with your hand at the right hand side of the knitting machine, move the K carriage to the opposite side.
- ※ Make sure the cast-on comb is removed from the gate pegs. This is done by moving the levers towards you and lowering the comb into the stitches.

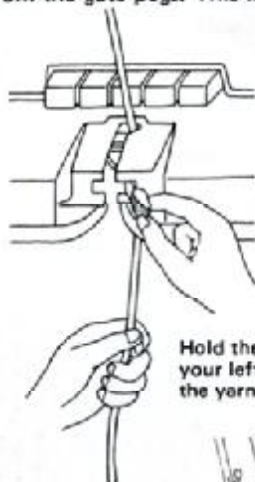

Hold the end of yarn with your left hand and close the yarn feeder lever.

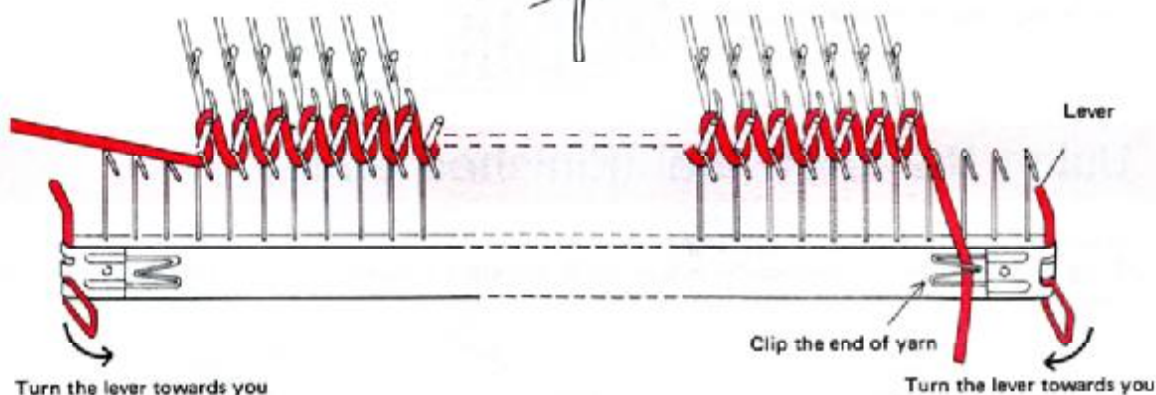

N.B.
If using the small cast-on comb, release the yarn from underneath the teeth of the comb upto the first needle.

- ⑤ Continue to operate the K carriage back and forth.

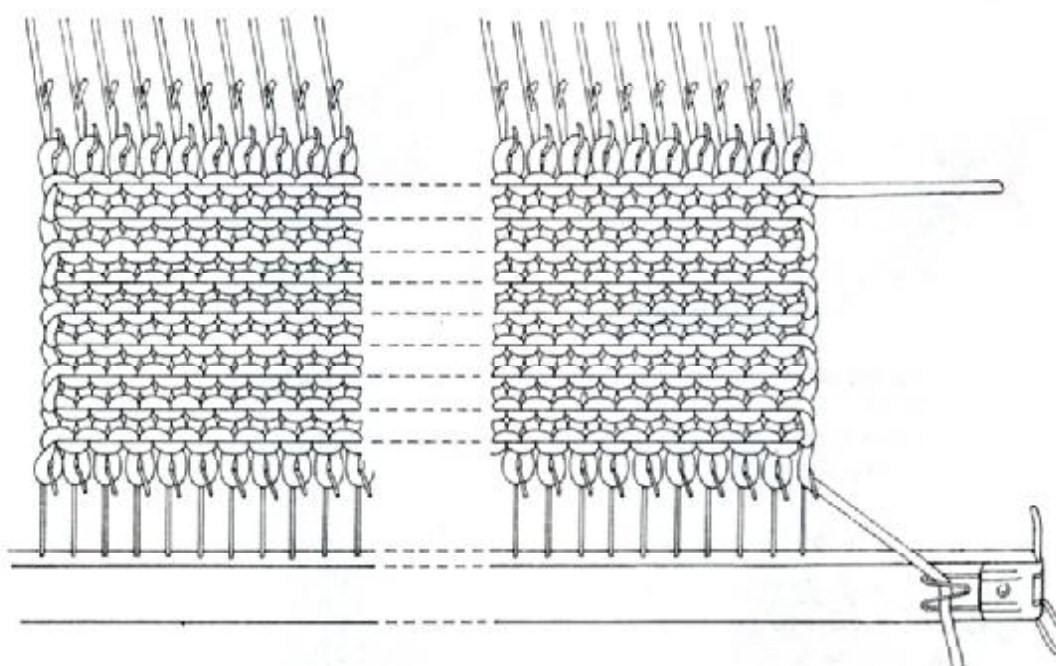

Hand method or "e" wrap (Finished edge)

N.B.

These methods are used for hems on skirts and tops.



- ① Hang the cast-on comb onto the gate pegs.
- ② Place the K carriage on the right side of the machine and bring forward all the required needles to position 'E'.
- ③ Loop the yarn around the left end needle anti-clockwise. (do not make the loop too tight)

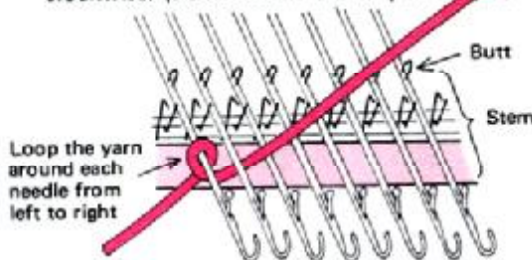

Do not make the loops too tight

- ④ At the right side pass the yarn under the end needle as shown in the diagram.
- ⑤ Place yarn in feeder 'A'.
- ⑥ Push stitches only back towards the gate pegs. Knit one row and lower the cast-on comb.

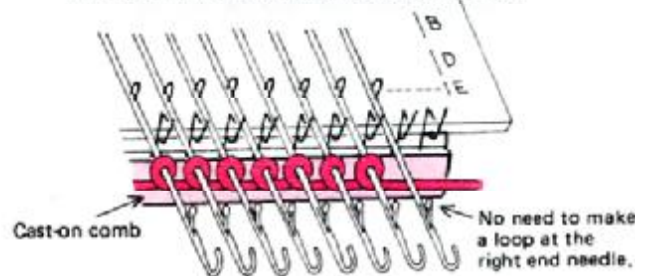

- ⑦ The finished edge of the cast-on is made.

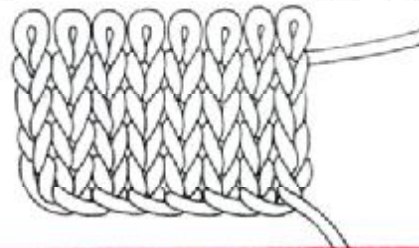

Using the latch tool (Finished edge)

- ① Hang the cast-on comb onto the gate pegs.
- ② Bring forward all the required needles to position 'E' and make a slip knot in the end of the yarn with the latch tool.



- ③ Put the latch tool between the left end needle and the second needle from the left and make a stitch by pulling down the latch tool.

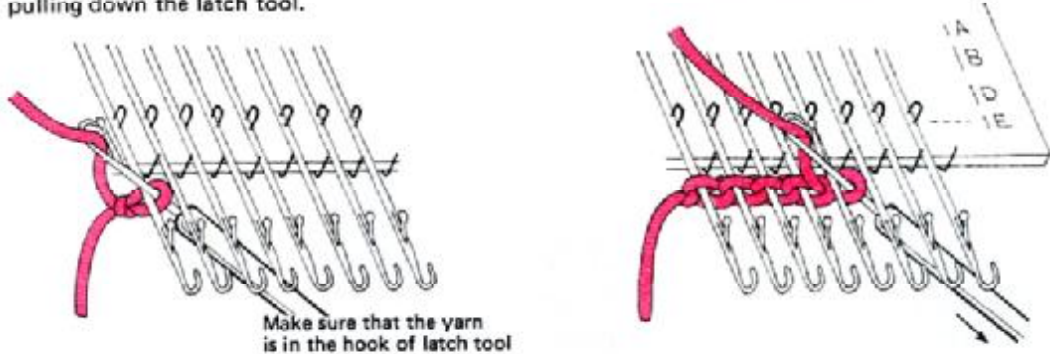

- ④ At the right, transfer the stitch which is on the latch tool to the hook of the needle.
- ⑤ Place yarn in feeder 'A'.
- ⑥ Push stitches only back towards gate pegs. Knit one row and lower the cast-on comb.
- ⑦ Finished edge of casting-on is made.

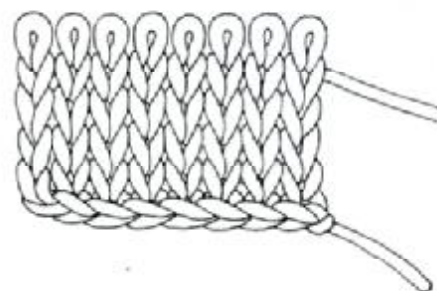
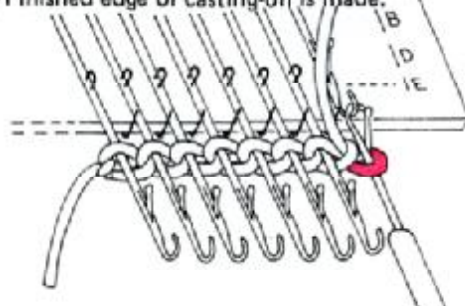

Using both "PART" buttons

① Bring forward all the required needles to position 'B' and bring forward every alternate needle starting with the right end needle from position 'B' to position 'D'. Push both 'PART' buttons.



② Knit one row.



③ Bring forward all opposite needles to position 'D'. (every alternate needle starting with the second needle from the right from position 'B' to position 'D')

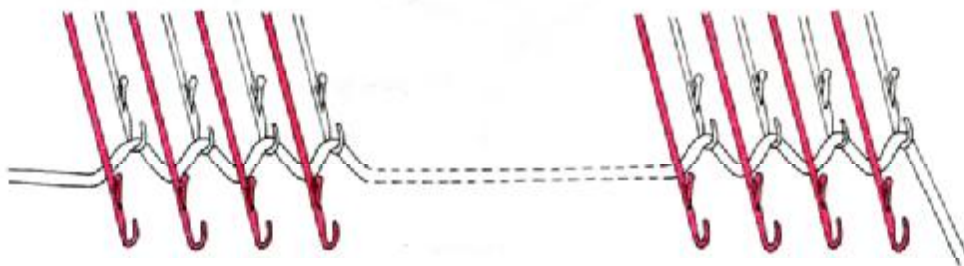

④ Knit one row and repeat these steps ① to ③ one more time.

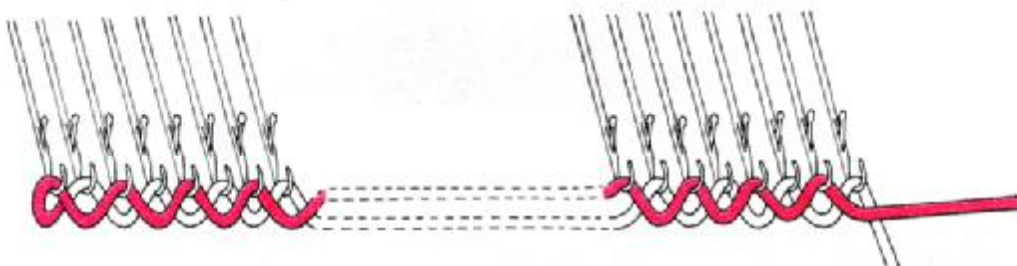

⑤ Cancel both 'PART' buttons and continue to knit, you are now doing plain knitting.

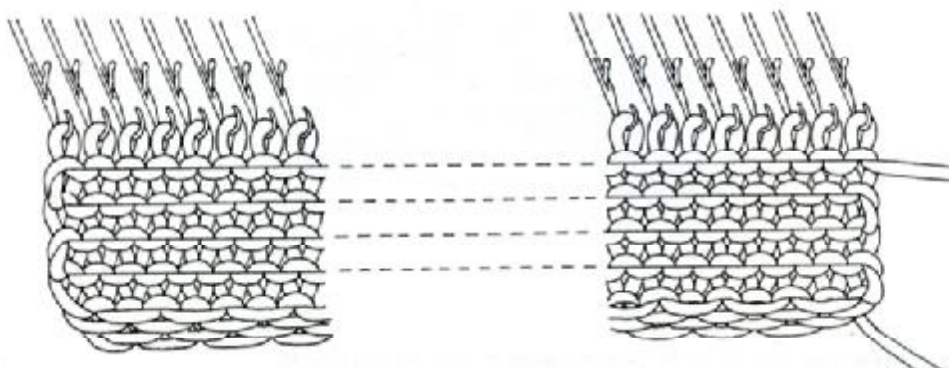

Using weaving pattern levers

① Place the K carriage on the right side of the machine and set both weaving pattern levers to position 'W.T.'.

② Bring forward all required needles to position 'B' and bring forward every alternate needle starting with the right end needle from position 'B' to position 'D'.

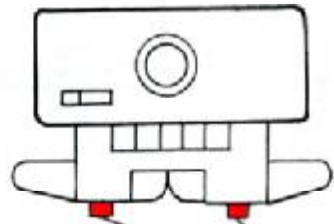

Set weaving pattern lever to 'W-T' position

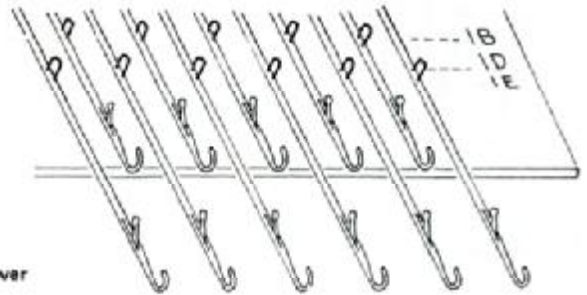

③ Thread yarn into yarn feeder 'A' and lay it over the needles or hold the yarn together underneath the needles as shown in the diagram.

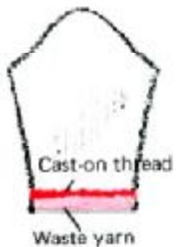
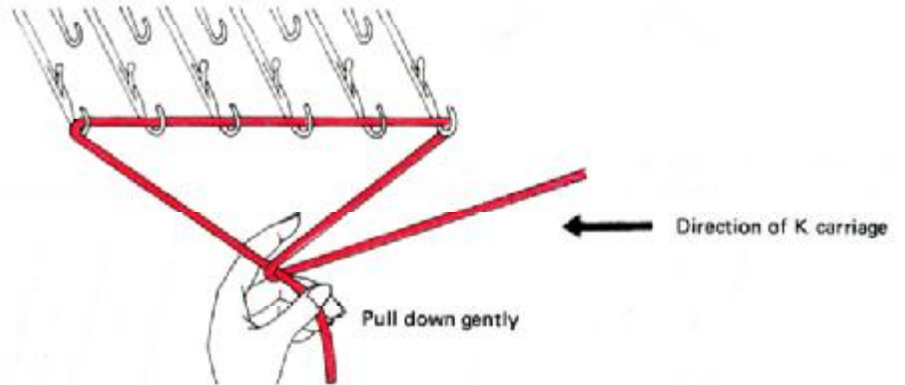

④ Move the K carriage slowly to the left side of the machine.

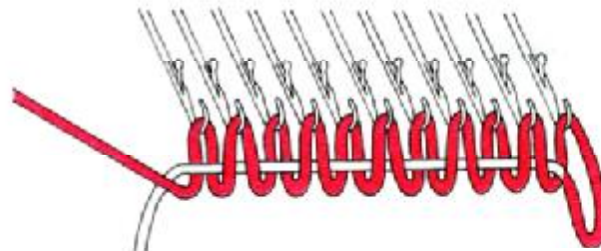

⑤ Continue to knit for several rows and return the weaving pattern lever to position 'N'. (if you are using a weaving pattern, leave both levers at 'W.T.' position)

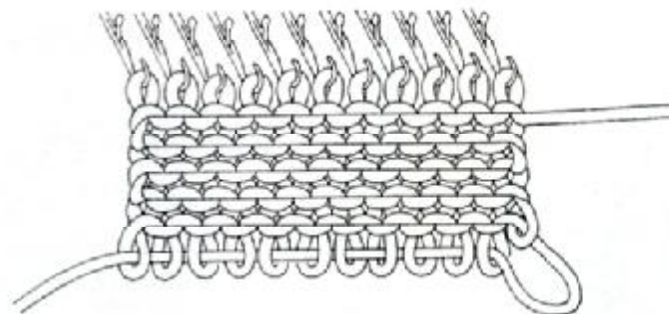

* If a loop forms at the right, pull the yarn through at the left to close the loop.

2 Finished Cast-on Edge

1×1 rib (Without ribbing attachment)

- ① Hang the cast-on comb onto the gate pegs, bring forward all the required needles to position 'B'. Starting with the third needle from the right end, push back every alternate needle to position 'A'.

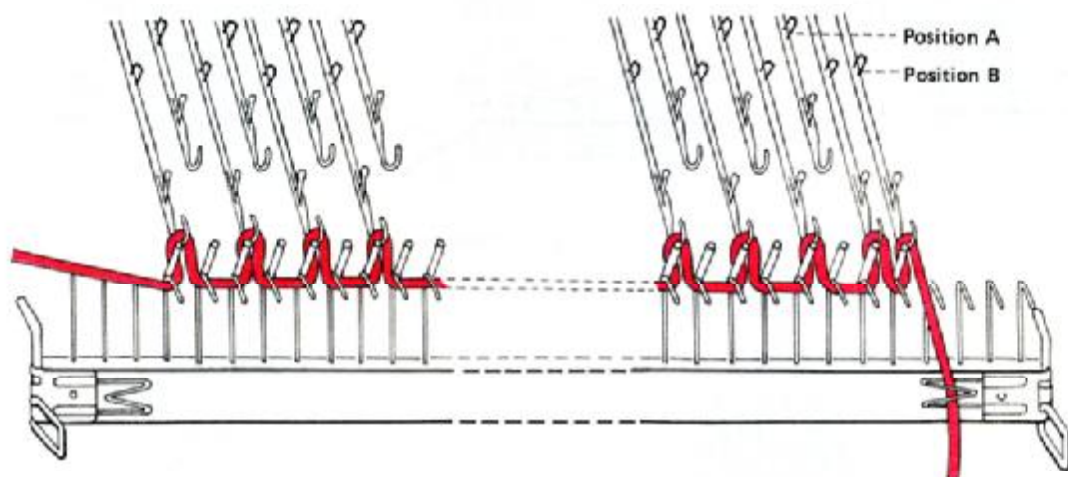

N.B.

When casting-on, always use an even number of needles plus 2 extra needles for the seams.

- ② Knit several rows with waste yarn and one row with the cast-on thread.

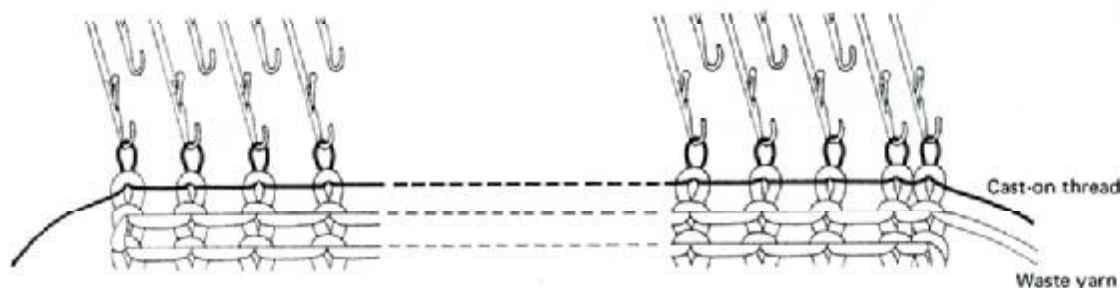

- ③ Reduce the tension dial two or three numbers from the main tension and knit three rows with the main yarn. Pick up both end loops of the first row and hang them onto the end KH needles as shown in the diagram. Bring forward all the 'A' position needles to position 'B'.

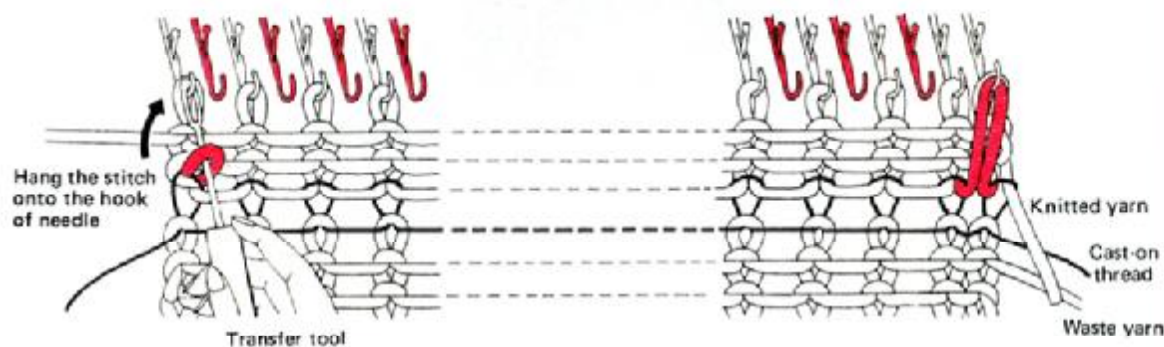

④ Knit the required rows for the rib with the main tension.

⑤ Drop the third stitch from the right end and unravel the stitches by using the tip of the latch tool.

⑥ Insert the latch tool under the sinker loop of the first row and catch the third parallel thread (mis two rows) with the hook of the latch tool, then pull the latch tool towards you to make a plain stitch

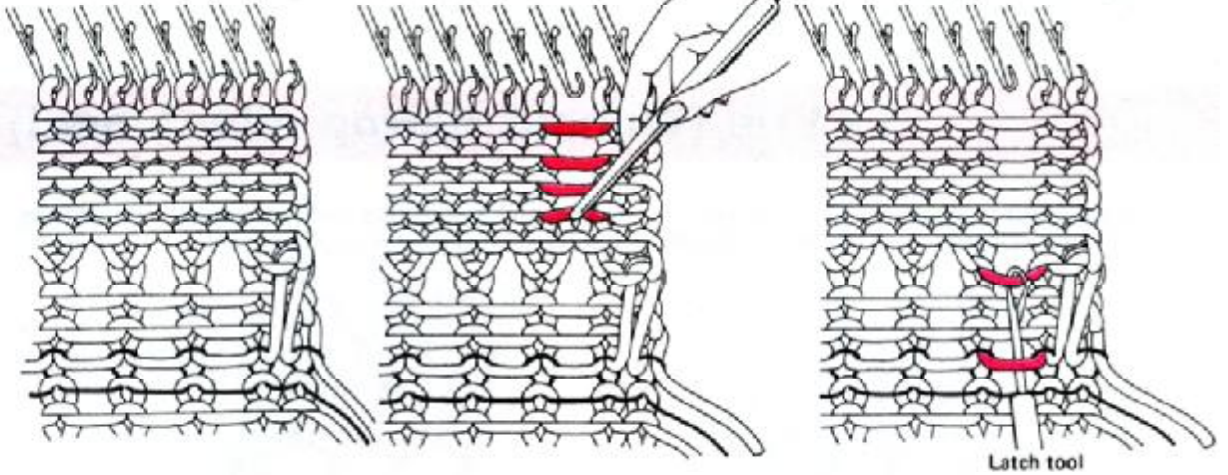

- ⑦ Repeat this until you reach the top, then hook the last stitch onto the hook of the needle.
 ⑧ Repeat this procedure as shown at step ⑥ on every alternate needle to make a 1x1 rib.

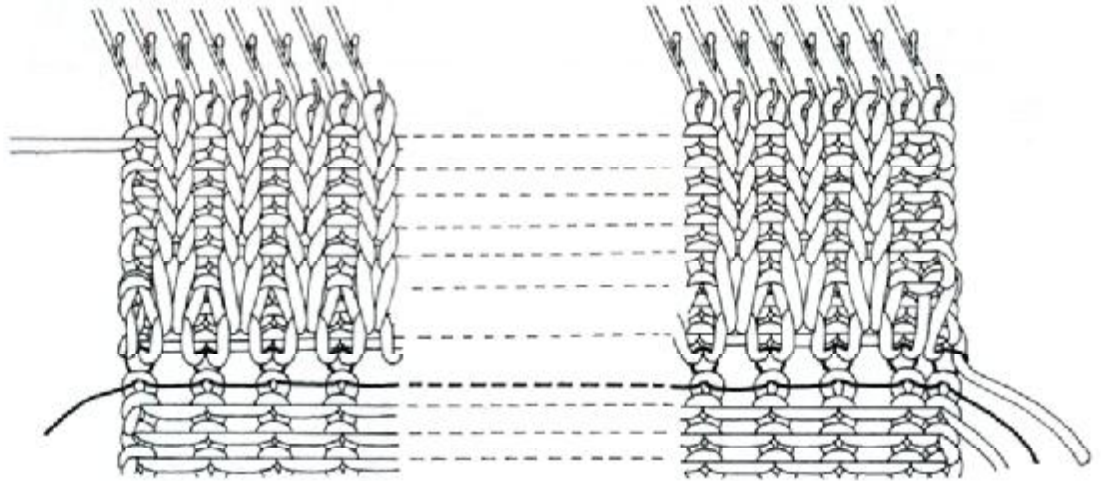

⑨ Pull out the cast-on thread, and the part knitted on waste yarn is removed and the 1x1 (hem) rib is made.

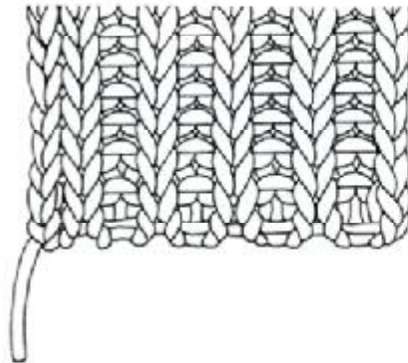

2x1 rib (1) (Without ribbing attachment)

- ① Hang the cast-on comb onto the gate pegs, bring forward all the required needles to position 'B'. Starting with the third needle from the right end, push back every third needle to position 'A'.

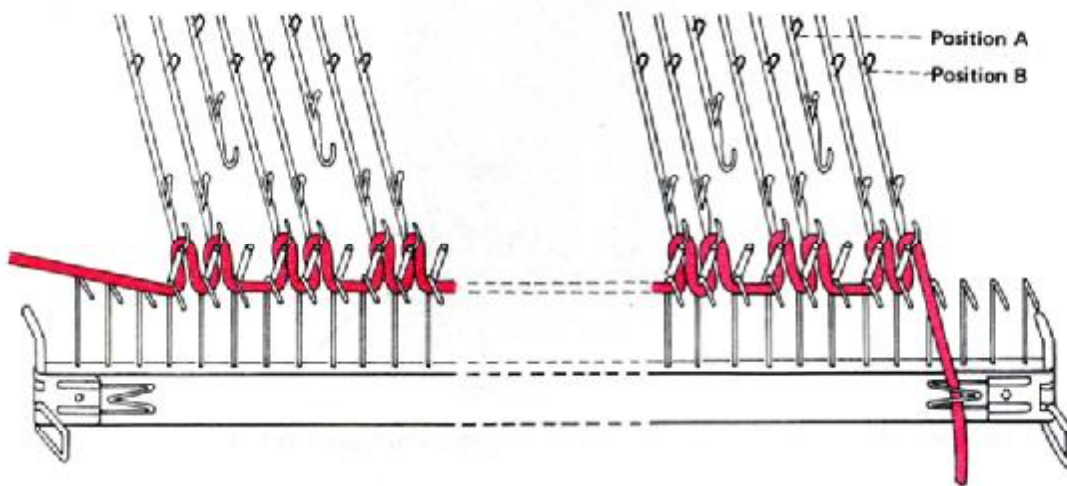

N.B.

When casting-on, always make sure that the number of needles required can be divided by 3.

Example: if pattern reads; Cast on 92 stitches, you will have to cast on 93 plus two extra needles for the seams.

- ② Knit several rows with waste yarn and one row with the cast-on thread.
 ③ Reduce the tension dial two or three numbers from the main tension and knit three rows with the main yarn.

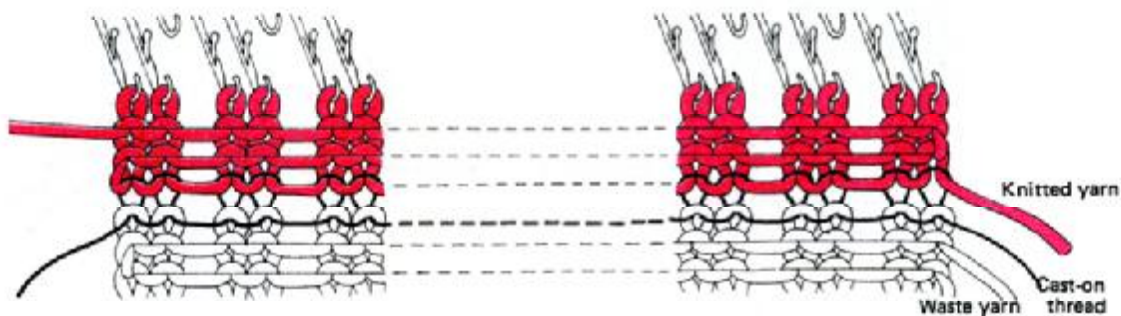

- ④ Using the transfer tool, pick up the sinker loops of the first row and hook them onto the corresponding KH needles as shown in the diagram.

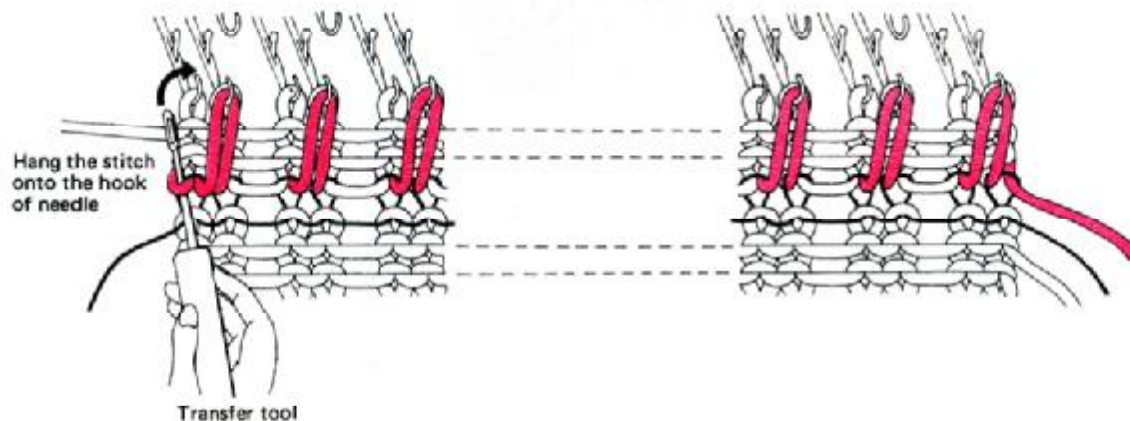

- ⑤ Drop the third stitch from the right end and unravel the stitches by using the tip of the latch tool. Insert the latch tool under the sinker loop of the first row and catch the third parallel thread (miss two rows) with the hook of the latch tool, then pull the latch tool towards you to make a plain stitch.

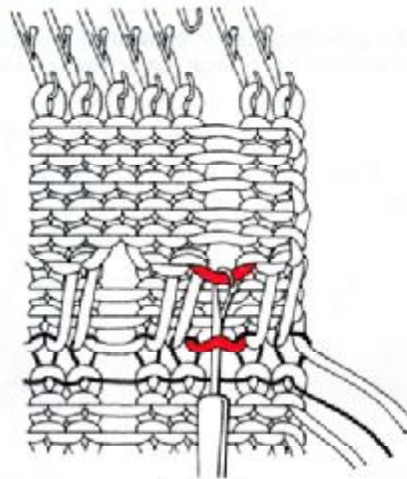

Latch tool

- ⑥ Repeat this procedure as shown at step ⑤ on every third stitch to make a 2x1 rib.

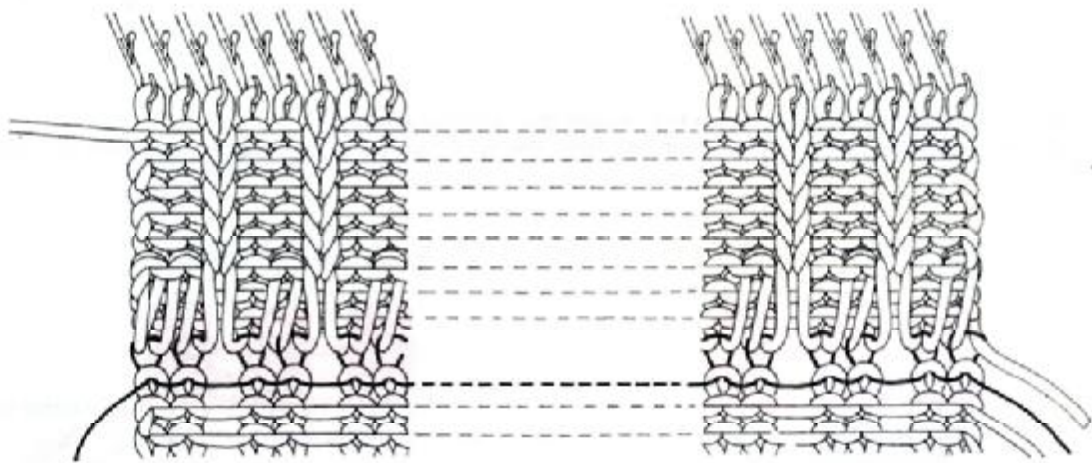

- ⑦ Pull out the cast-on thread, the part knitted in waste yarn is removed and the 2x1 rib (hem) is made.

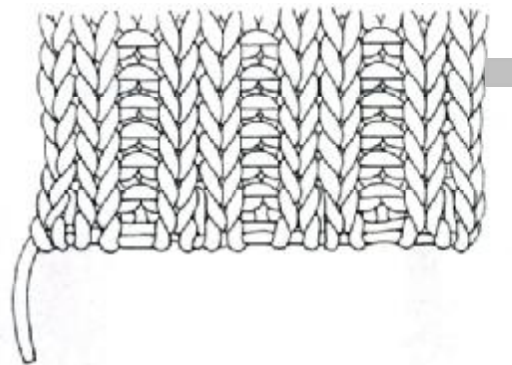

2×1 rib (2) (Without ribbing attachment)

- ① Bring forward all the required needles to position 'B' and knit several rows in plain knitting with waste yarn, then place the K carriage on the left side of the machine. Knit one row with the cast-on thread and push both 'PART' buttons. Starting with the second needle from the right end, bring forward every third needle to position 'D'.

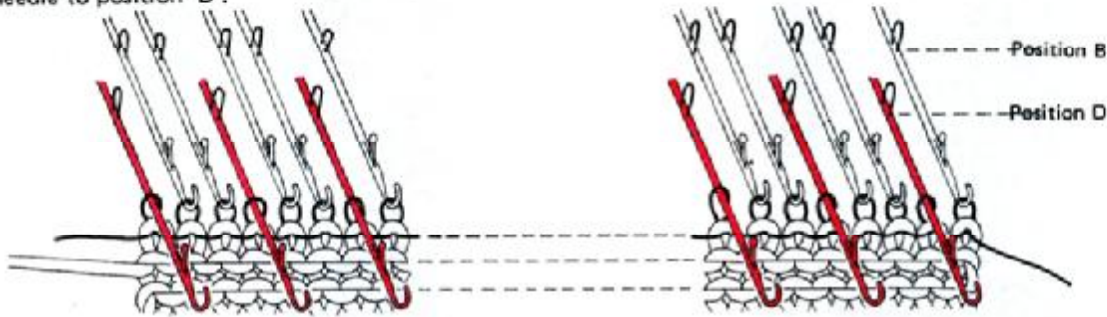

- ② Knit one row from right to left with the main yarn on the main tension. Starting with the second needle from the left end, bring forward every third needle to position 'D' and knit one row from left to right.

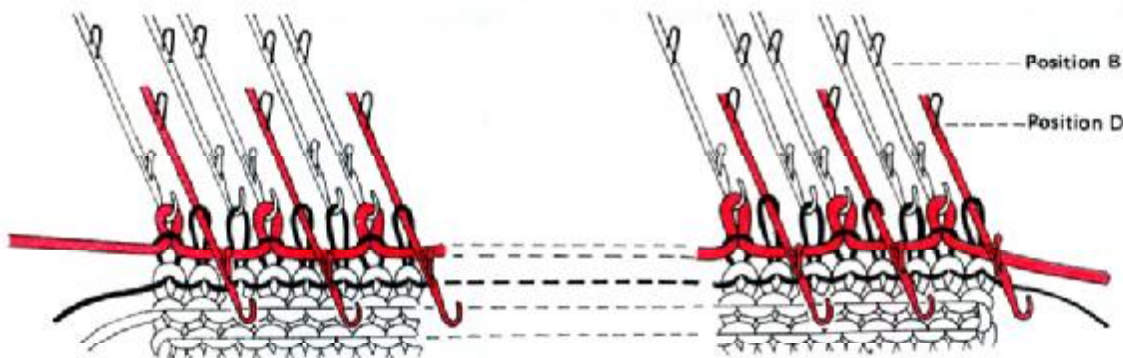

- ③ Cancel the 'PART' buttons, and knit the required rows for the rib.

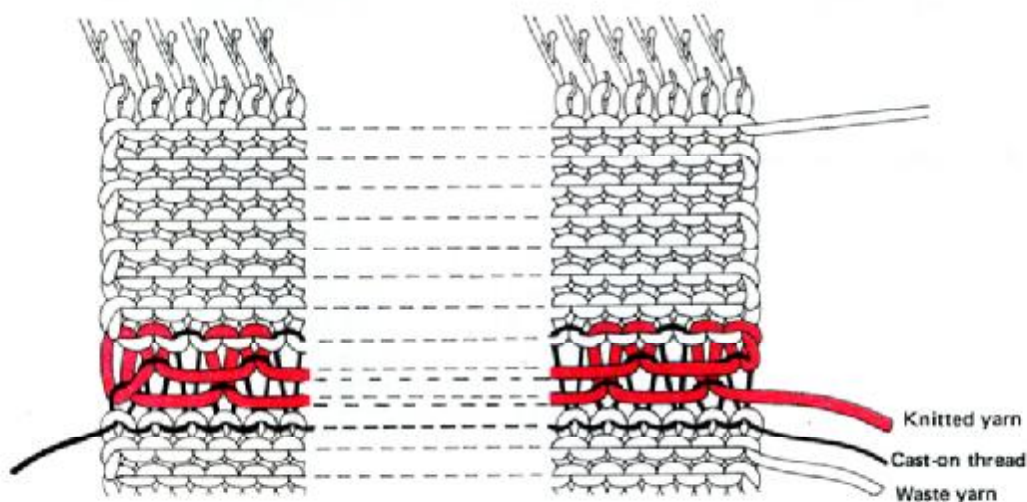

N.B.

When casting-on, always make sure that the number of needles required can be divided by 3.

Example: if pattern reads; Cast on 92 stitches, you will have to cast on 93 plus two extra needles for the seams.



④ Drop the third stitch from the right end and unravel the stitches by using the tip of the latch tool. Insert the latch tool under the sinker loop and catch the first skip-stitch with the hook of it, as shown in the diagram.

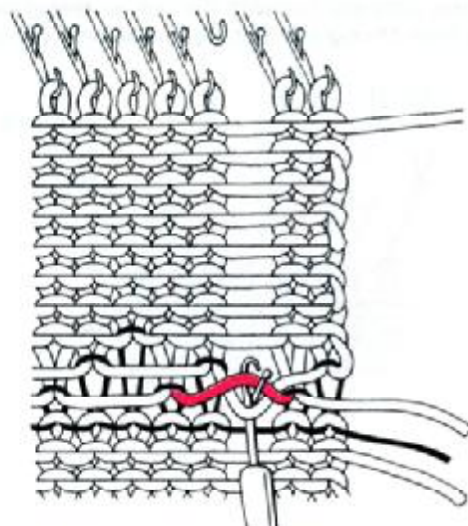

Latch tool

⑤ Pull the latch tool towards you and catch the next two parallel threads with the hook of the latch tool.

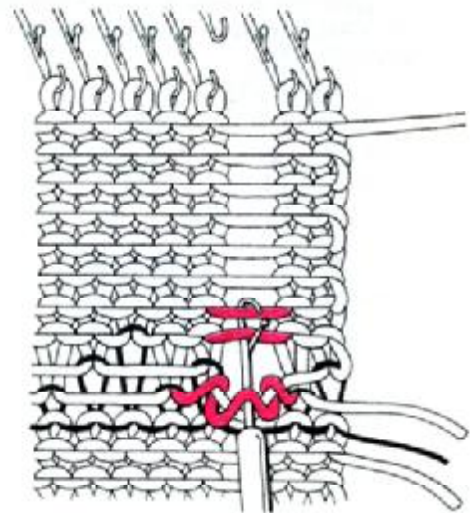

⑥ Pull the latch tool towards you. From the next row, pick up every parallel thread individually to make the rib.

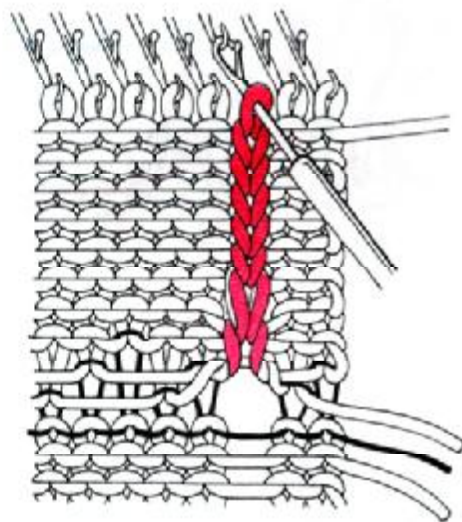

⑦ Repeat these steps ④-⑥ on every third stitch to make the 2x1 rib.

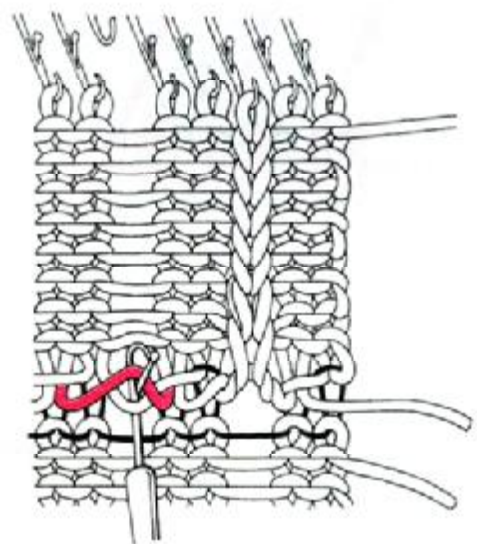

⑧ Pull out the cast-on thread, the part knitted with waste yarn is removed and the 2x1 rib (hem) is made.

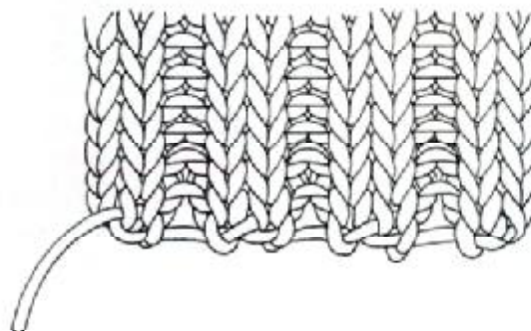

2x2 rib (1)

- ① Hang the cast-on comb onto the gate pegs, bring forward all the required needles to position 'B'. Starting with the third and fourth needles from the right end, arrange every third and fourth needles for a 2x2 rib by pushing them back to position 'A'.

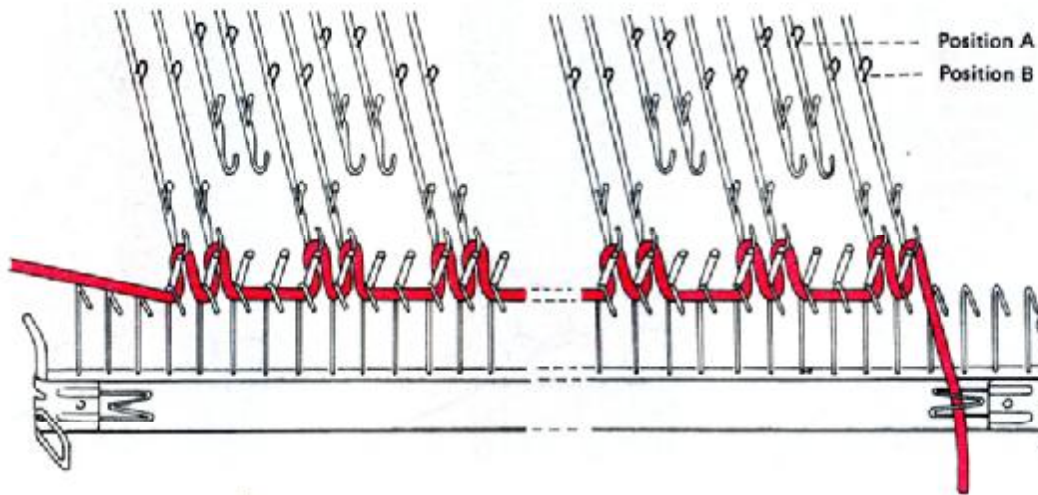

- ② Knit several rows with waste yarn and one row with the cast-on thread. Reduce the tension dial two or three numbers from the main tension and knit three rows with the main yarn.

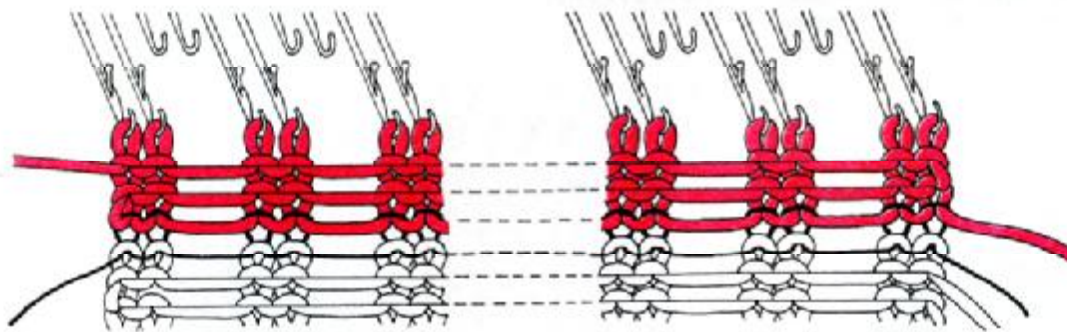

- ③ Using the latch tool, pick up the sinker loops of the first row and hang them onto the hooks of the needles, as shown in the diagram.

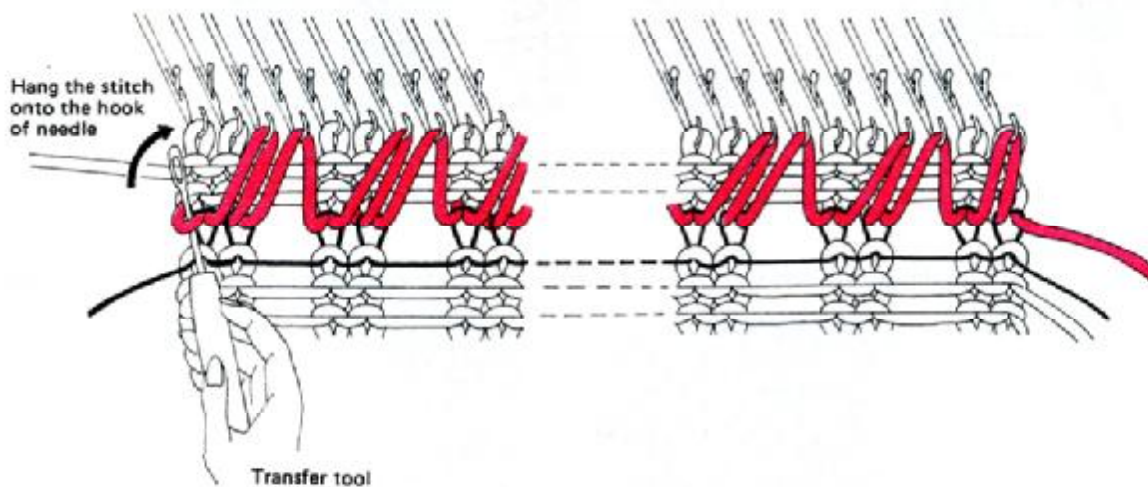

N.B.

When casting-on always use an even number of needles, multipliable by 4 plus two extra needles for the seams.



④ Knit the required rows with the main tension. Drop the third stitch from the right and unravel the stitches by using the tip of the latch tool.

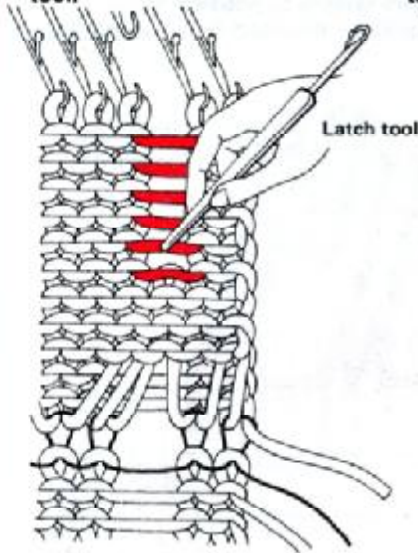

⑤ Insert the latch tool under the sinker loop of the first row and catch the third parallel thread (miss two rows) with the hook of the latch tool, then pull it towards you to make a new stitch.

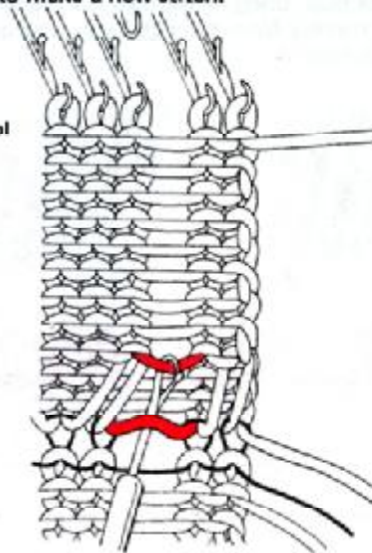

⑥ Repeat this until you reach the top and hook the last stitch onto the hook of the needle.

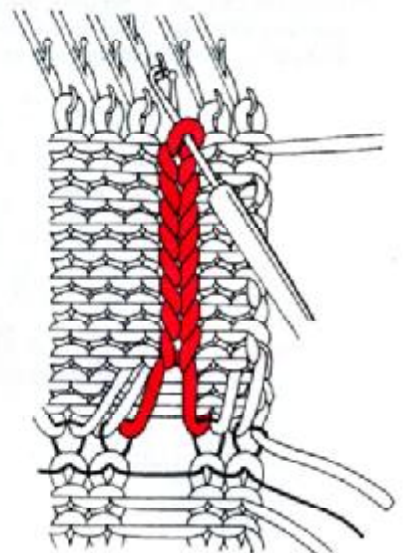

⑦ Drop the fourth stitch from the right end and repeat these steps ④ and ⑤ to make the rib.

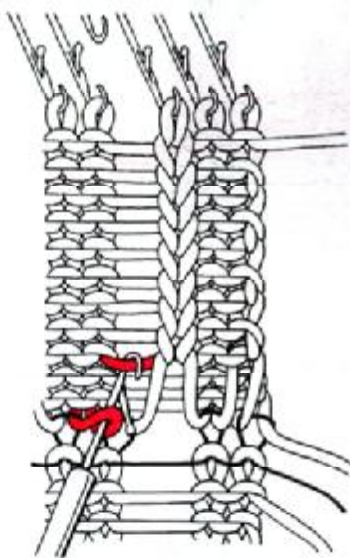

⑧ Repeat these steps ④-⑦ at an interval of two needles (stitches) to make a 2x2 rib.

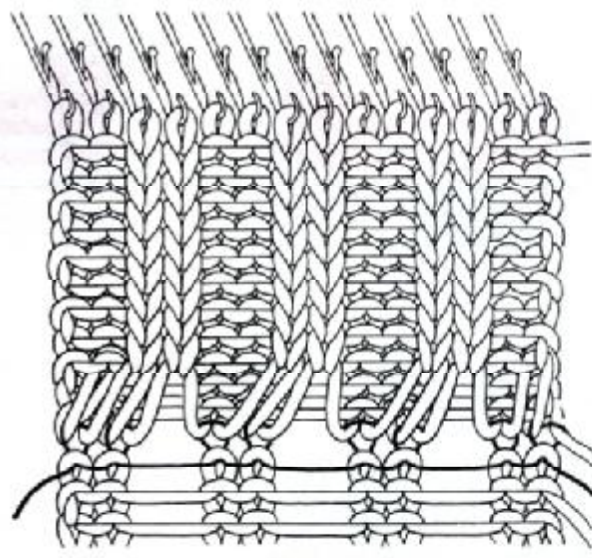

⑨ Pull out the cast-on thread, the part knitted with the waste yarn is removed and the 2 x 2 rib (hem) is made.

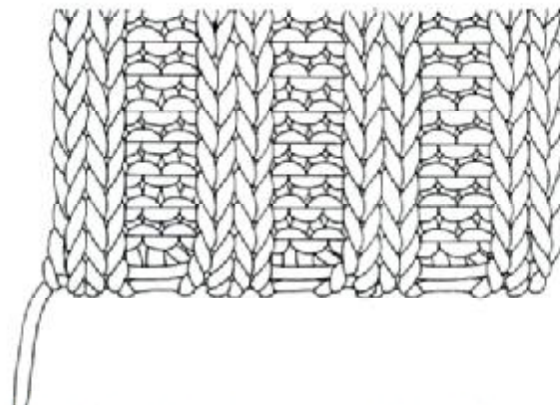

2x2 rib (2)

- ① Bring forward all the required needles to position 'B'. Knit several rows in plain knitting with waste yarn and one row with the cast-on thread. Increase the tension dial two or three numbers from the main tension and knit one row with the main yarn. Reset the tension dial to the main tension and knit the required rows for the rib.

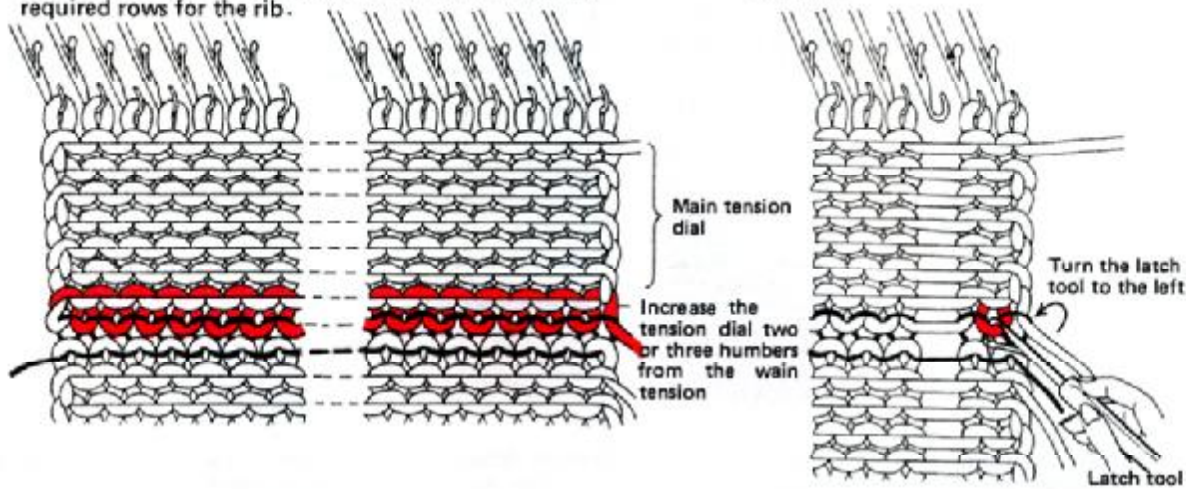

- ③ Catch the first parallel thread and make a new stitch, then repeat this until you reach the top.

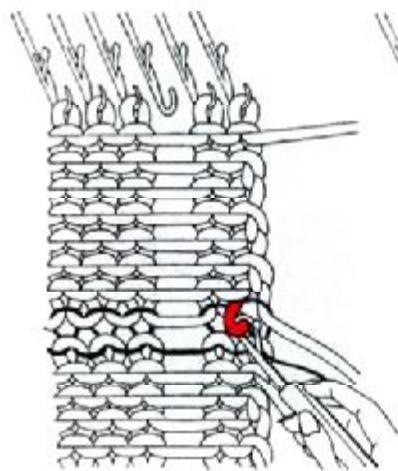

- ④ Drop the fourth stitch from the right end and unravel the stitches. Catch the left adjacent sinker loop of the fourth stitch and turn it to the right to twist the stitch, as shown in the diagram.

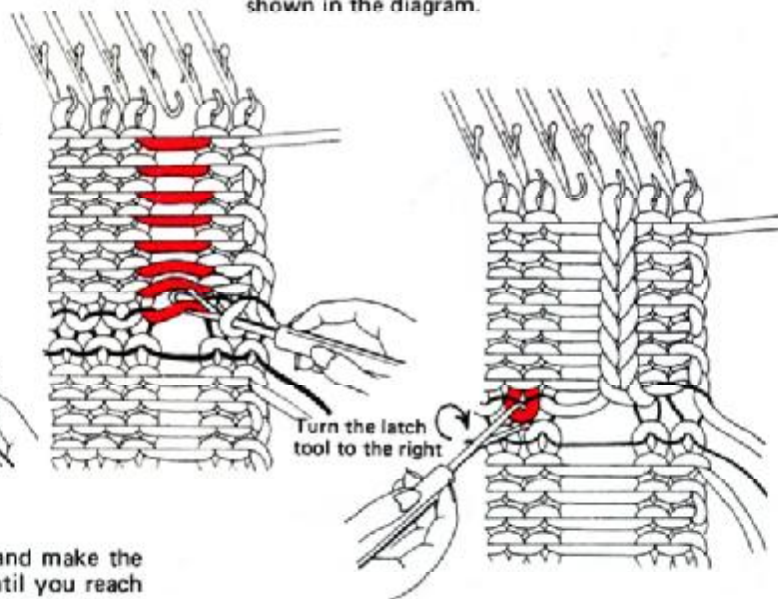

- ⑤ Catch the first parallel thread and make the new stitch, then repeat this until you reach the top. Repeat steps ②-⑤ at an interval of two needles (stitches) to make a 2x2 rib.

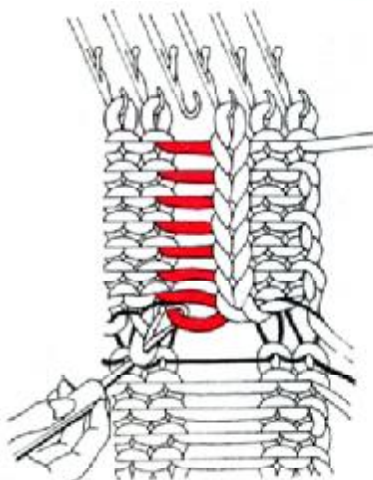

- ⑥ Pull out the cast-on thread, the part knitted with waste yarn is removed and the 2x2 rib (hem) is made.

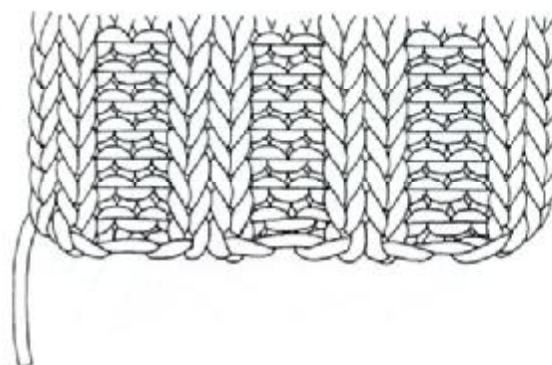

N.B.

When casting-on always use an even number of needles, multipliable by 4 plus two extra needles for the seams.



A) Plain hem (Cast-on edge)

- ① Bring forward all the required needles to position 'B'. Knit several rows with the waste yarn and one row with the cast-on thread. Knit the required rows for double the length of the hem with the main yarn.

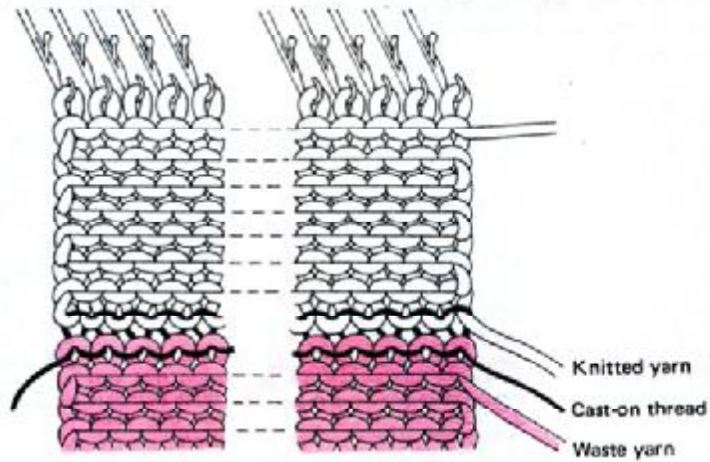

- ② Using the transfer tool, pick up all the sinker loops on the first row of the main yarn and hook them onto the hooks of the needles. As shown in the diagram.

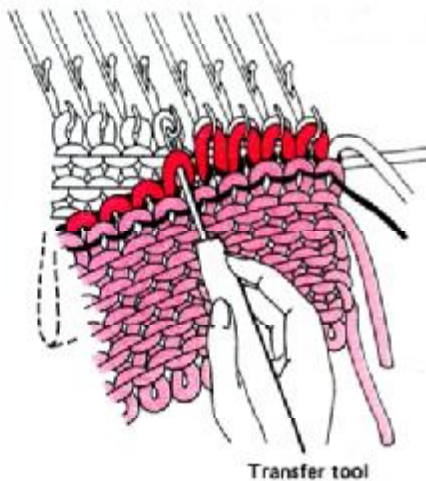

- ③ Bring forward all the needles to position 'E'. Increase the tension dial two or three numbers from the main tension and knit one row. Reset the tension dial to the main tension, and continue to knit with the main yarn. Pull out the cast-on thread, the part knitted with the waste yarn is removed and the plain hem is made.

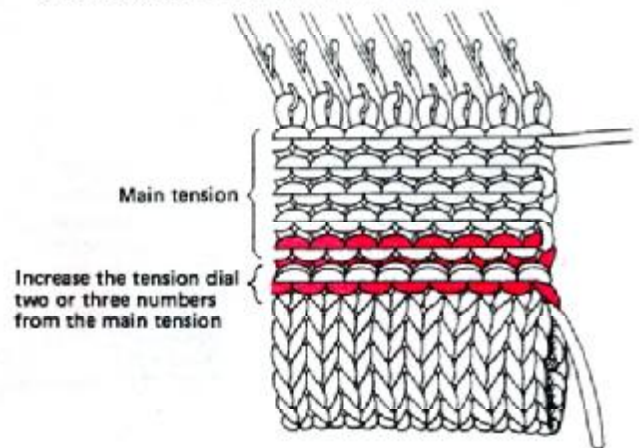

B) Plain hem (Cast-off edge)

- ① At the hem point, increase the tension dial two or three numbers from the main tension and knit one row. Reset the tension dial to the main tension and knit the required rows for double the length of the hem. Pick up all the sinker loops at the hem point and hook them onto the needles, as shown in the diagram.

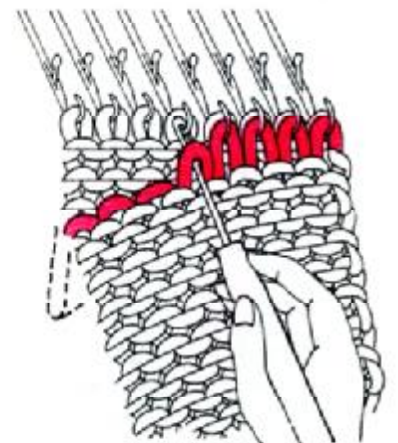
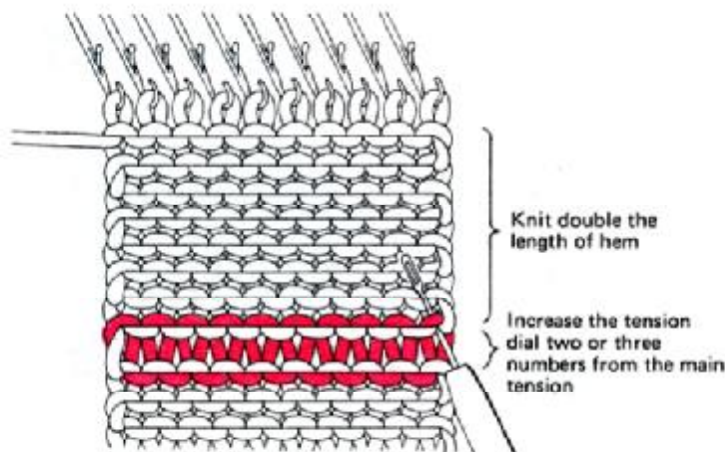

② Slide all the stitches on the last row behind the latches of the needles as shown in the diagram. (picked up stitches must remain in the hooks of the needles.) Bring forward all the needles to position 'D'. Push back the needles one by one to position 'B' by hand to make a single stitch. Take the swatch off the machine after binding off all the stitches.

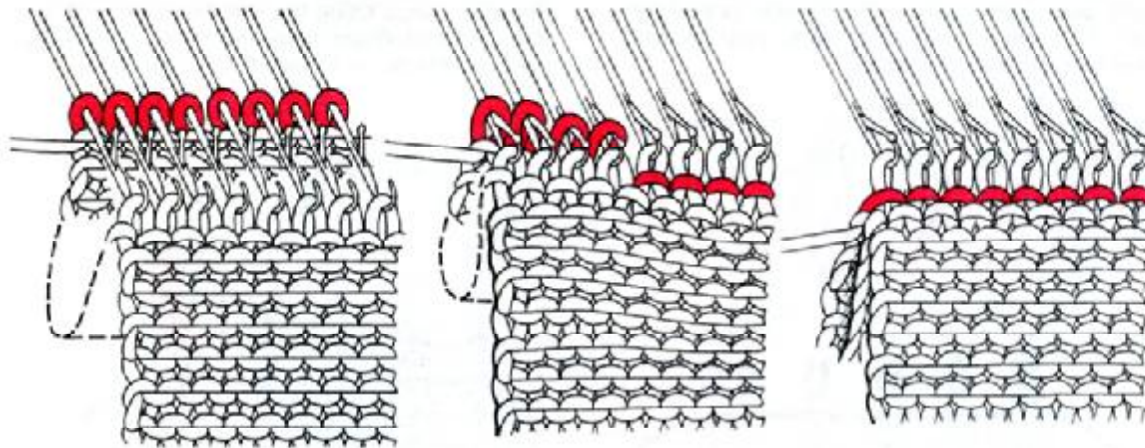

C) Picot hem (Cast-on edge)

① Bring forward all the required needles to position 'B'. Knit several rows with waste yarn and one row with the cast-on thread. Knit up to half the depth of the hem with the main yarn. Using the L carriage, transfer every other stitch to the adjacent needle.

② Knit the other half of the hem and one more row.

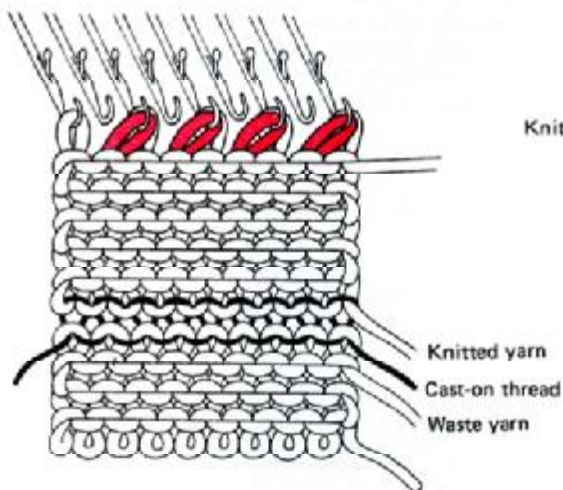

Knit one extra row

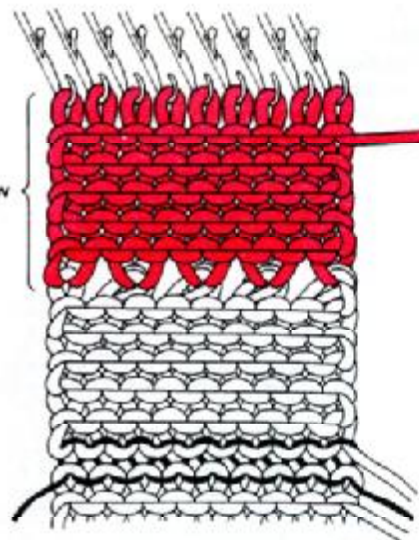

③ Using the transfer tool, pick up the sinker loops of the first row of the main yarn and hook them onto the needles, as shown in the diagram. Bring forward all the needles to position 'E'. Increase the tension dial two or three numbers from the main tension and knit one row.

④ Pull out the cast-on thread, the part knitted with the waste yarn is removed and a picot hem is made.

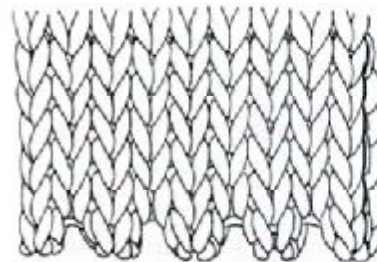
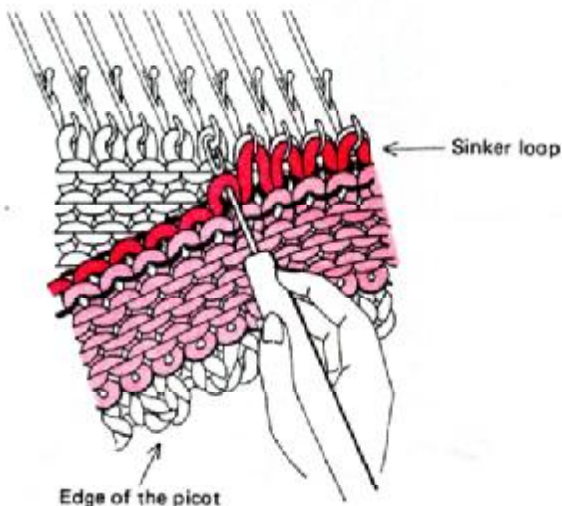

D) Mock rib (Cast-on edge)

① Bring forward all the required needles to position 'B'. Starting with the third needle from the right end, push back every other needle to position 'A'. Knit several rows with waste yarn and one row with the cast-on thread.

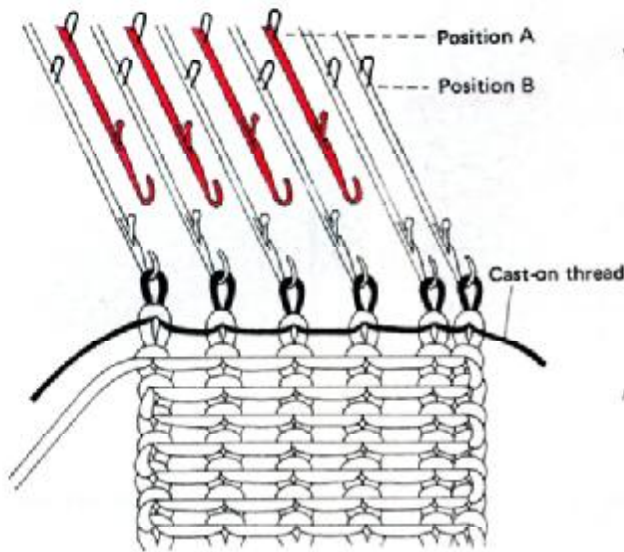

② Reduce the tension dial two or three numbers from the main tension and knit three rows with the main yarn. Using the transfer tool, pick up the right end sinker loop and hook it onto the right end needle, as shown in the diagram.

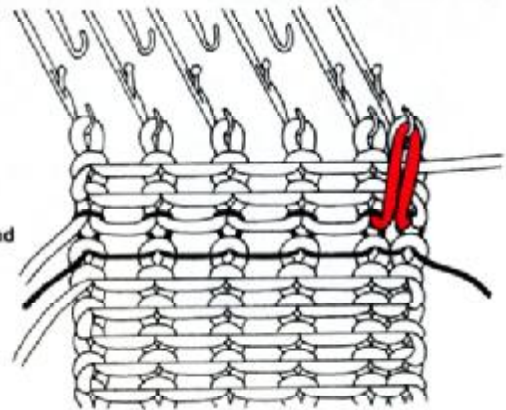

③ Bring forward all the 'A' position needles to position 'B' and knit two rows with the main tension. Starting with the right end needle, bring forward every other needle to position 'D', as shown in the diagram.

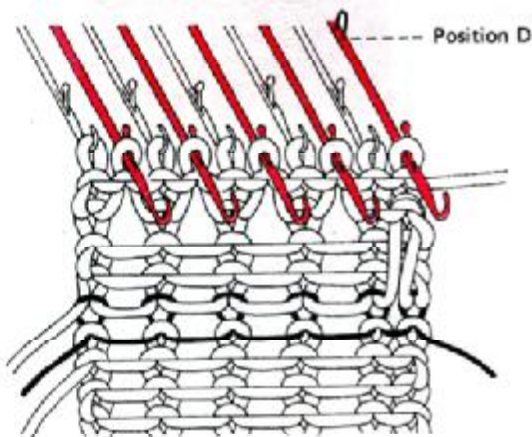

④ Push both 'PART' buttons and knit one row with the tension dial one number lower than the main tension. (This time only 'D' position needles are knitted) Starting with the second needle from the right end, bring forward every other needle to position 'D' and knit one row.

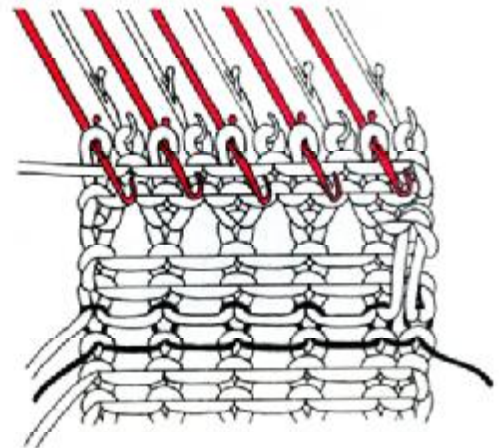

⑤ Repeat these steps ③ and ④, and knit another six rows.

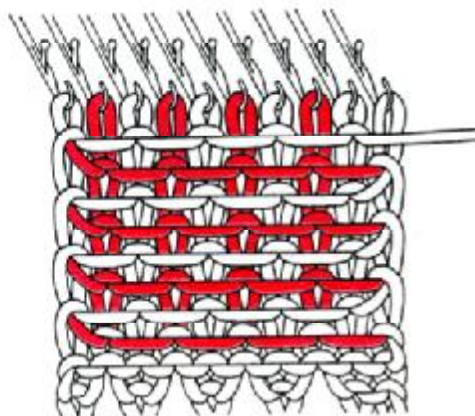

⑥ Starting with the third stitch from the right end, make the rib by using the latch tool. (pick up the marked parallel thread with hook of the latch tool) Continue to knit the 1 x 1 rib.

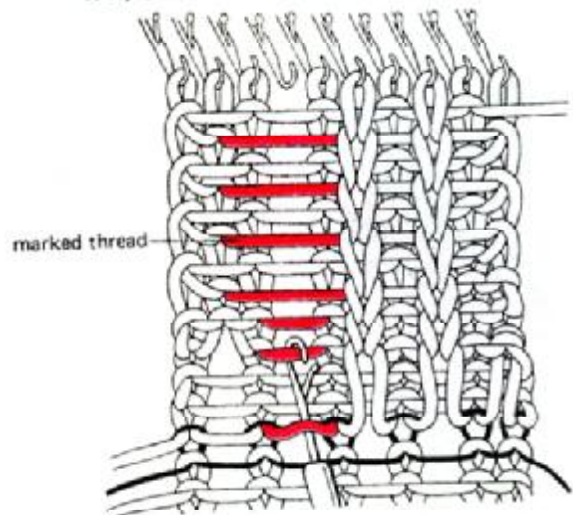

E) Mock rib (Cast-off edge)

① Knit upto the mock rib point and make a 1x1 rib by using the latch tool. (Place the K carriage on the left side of the machine) Starting with the right end needle, bring forward every other needle to position 'D' as shown in the diagram. Reduce the tension dial by one number.

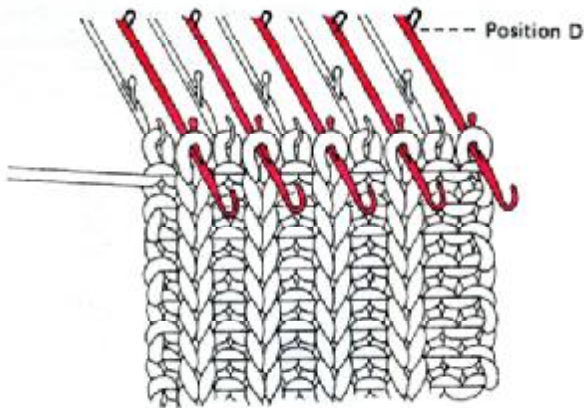

② Push both 'PART' buttons and knit one row from left to right. (This time only 'D' position needles are knitted)

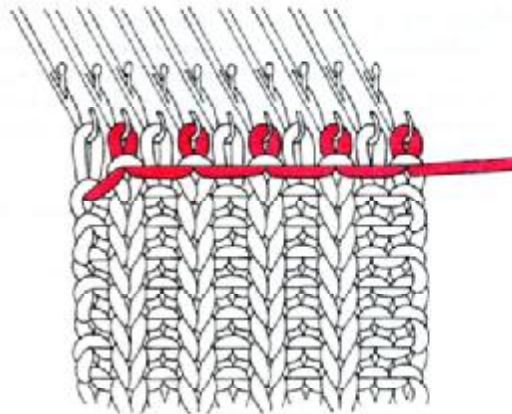

③ Starting with the second needle from the right end, bring forward every other needle to position 'D' and knit one row from right to left. Repeat these steps ①-③ and knit another six rows.

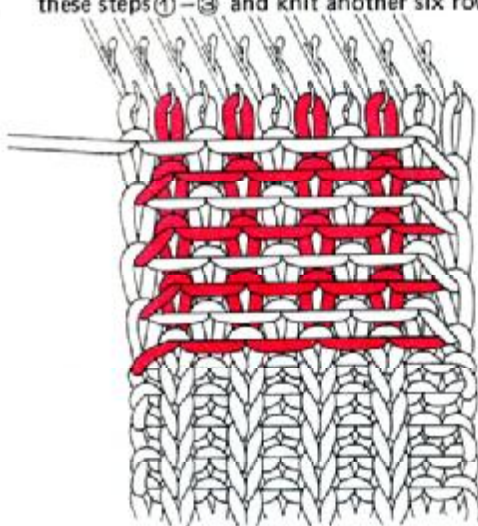

④ Insert the latch tool into the stitch of the last row on the 1x1 rib and pick up every other parallel thread to make the mock rib as shown in the diagram.

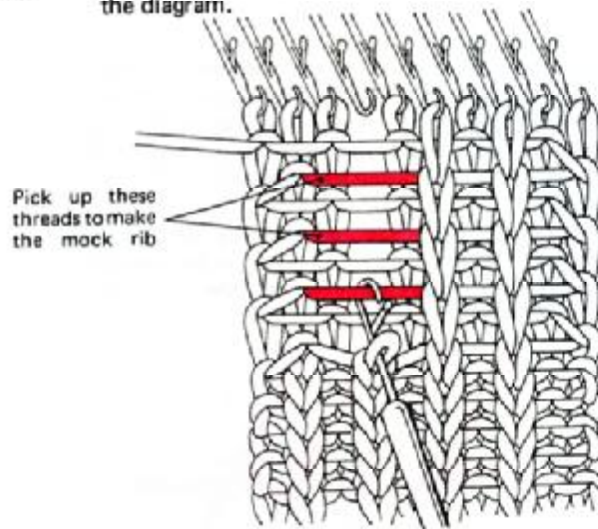

Application (When you use a wide elastic ribbed band, make the mock rib in the following manner)

① Bring forward all the required needles in odd numbers to position 'B'. Knit the required rows for the rib. Starting with the third stitch from the end, make the rib on every other stitch.

② Push both 'PART' buttons. Bring forward all the odd number needles to position 'D' and knit one row. Repeat this and knit another three rows then cut the main yarn. Re-thread the main yarn into yarn feeder and bring forward all the even number needles to position 'D' and knit one row. Repeat this and knit another three rows.

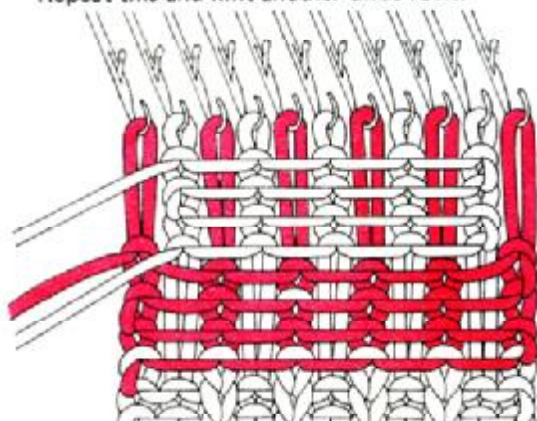

③ To make the mock rib, pick up every odd number stitch and make the rib by using the latch tool, as shown in the diagram.

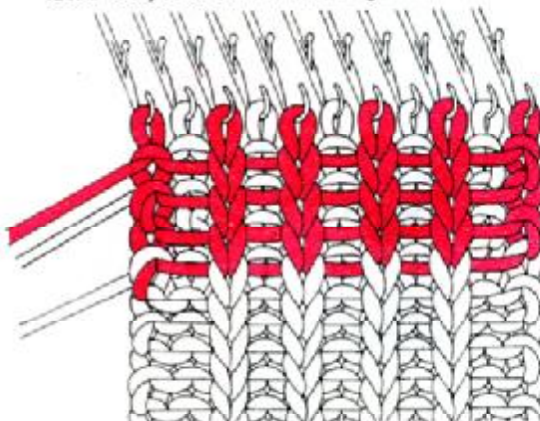

Various types of hems

A) Folded part of the hem is a 1×1 needle arrangement

① Place the K carriage on the right side of the machine and bring forward every alternate needle from position 'A' to position 'B'. Starting with the left end needle, loop the yarn anti-clockwise around each needle from left to right, as shown in the diagram.

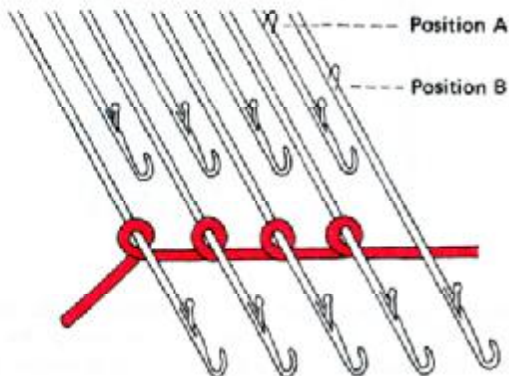

② Knit the required rows for half the length of hem with a 1x1 open stitch pattern. (at this time, the 1x1 open stitch pattern will be expanded, therefore, cut about 40% rows from the plain knitting. Ex. If there are 11 plain knitted rows, seven rows are enough for the 1x1 open stitch pattern)

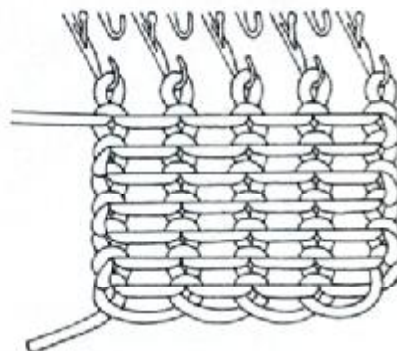

③ Take the yarn out of the yarn feeder and place the K carriage on the right side of the machine. If the K carriage is on the left side, push both 'PART' buttons and operate it to the right side without yarn in the feeder. Cancel both 'PART' buttons.

Bring forward all the 'A' position needles to position 'E' and loop the yarn anti-clockwise around each needle from left to right, as shown in the diagram.

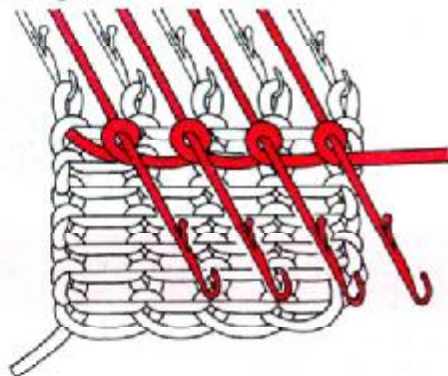

④ Knit required rows for the other half of the hem with plain knitting.

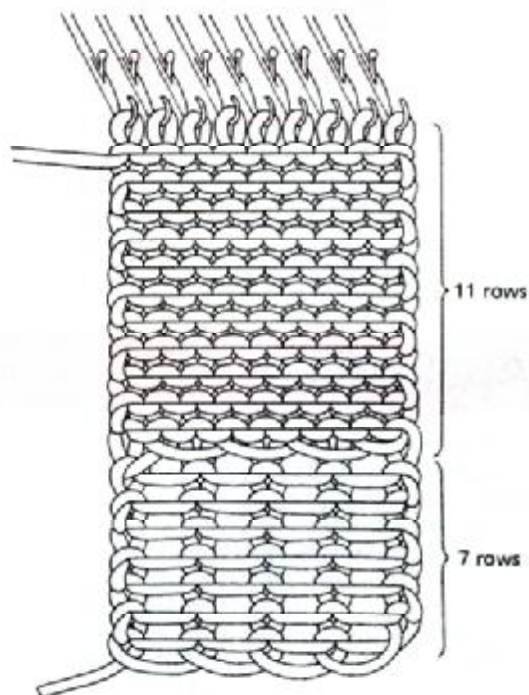

⑤ Using the transfer tool, pick up the looped stitches and hook them onto the needles. Bring forward all the needles to position 'E' and knit one row with the tension dial one number higher than the main tension.

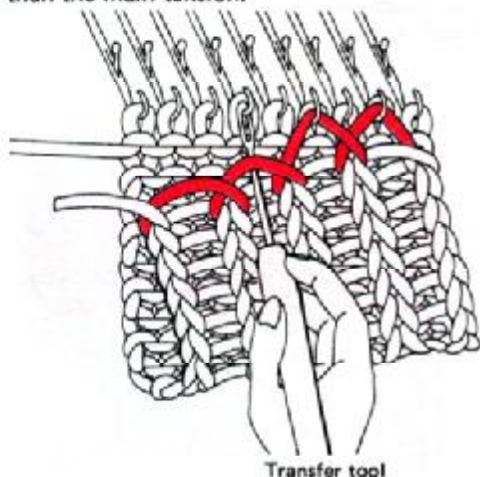

Transfer tool



B) 1 × 1 elastic hem

① Cast-on in the same manner as in item A)-① on page 20. Knit required rows for the double length of the 1x1 elastic hem.

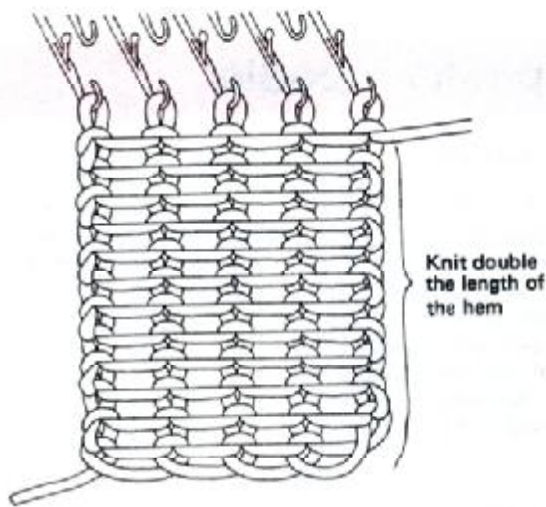

② Using the transfer tool, pick up the looped stitches and hook them onto the needles. Bring forward all the needles to position 'E' and increase the tension dial by one number, then knit one row.

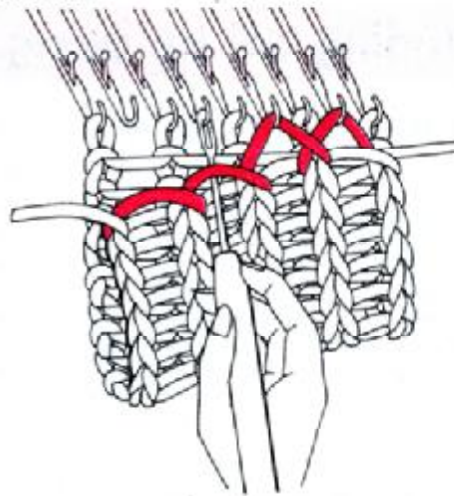

C) Put the 1 × 1 elastic hem between the plain knitting

① Knit up to the 1x1 elastic hem point in plain knitting. Bring forward all the even number needles to position 'D' and push both 'PART' buttons, then knit one row. Repeat this and knit the required rows for the 1x1 elastic hem.

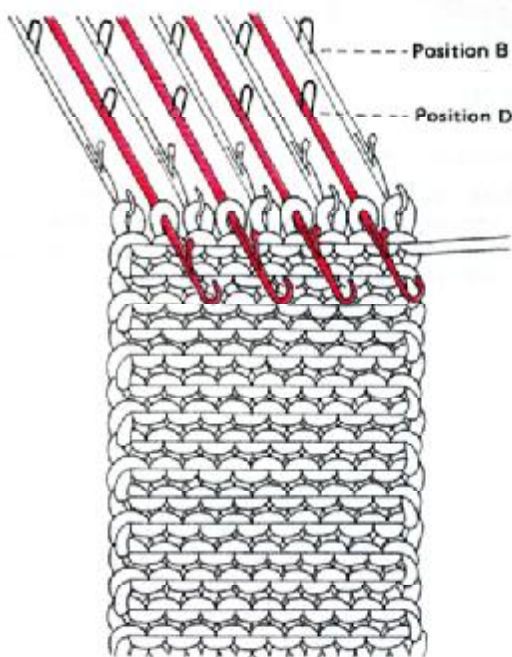

② After knitting the length of the hem, take the stitches off on waste yarn.

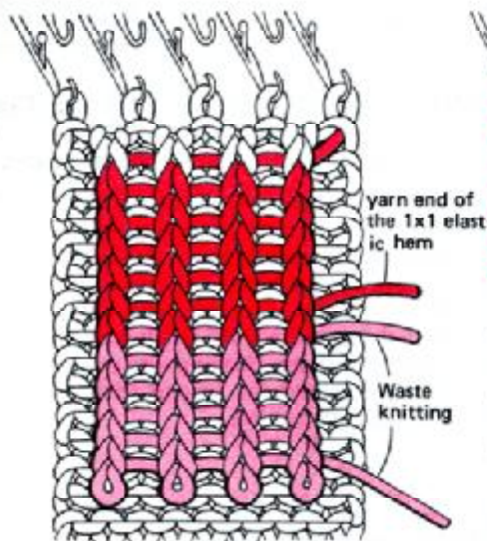

③ Cancel both 'PART' buttons and knit the SAME number of rows on the remaining needles as the section now on waste yarn.

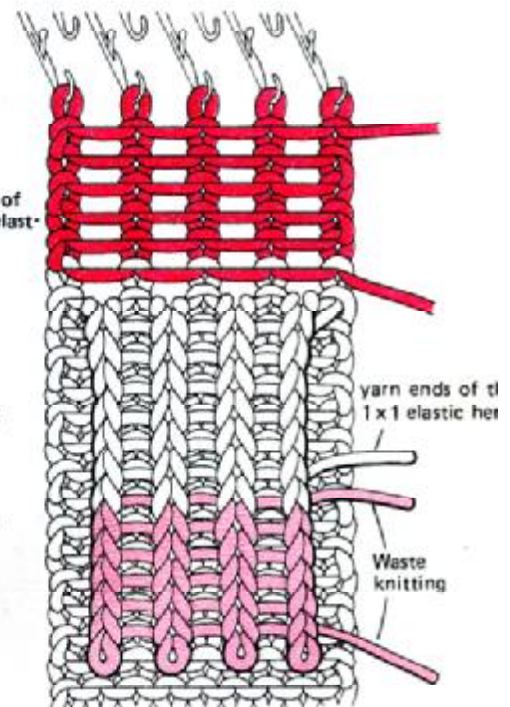

④ Fold the waste knitting towards the knitting machine, pick up all the stitches (even number stitches) and hook them onto the needles. Then take the waste knitting off.

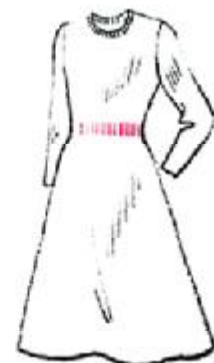
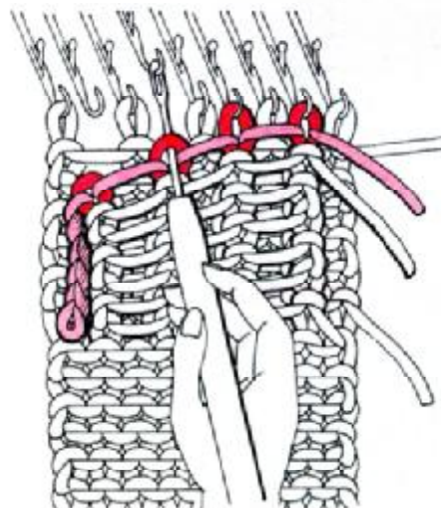

3 Cast-off Edge

Binding off by using a tapestry needle

A) When the yarn is on the left side of the knitting

※(Cut the main yarn leaving a length of three times the width of the knitting)

- ① Knit several rows with waste yarn after finishing the required length. Thread the main yarn into the tapestry needle. Pass the tapestry needle through the first left end stitch. Insert the tapestry needle into the second stitch from the left and pass it back through the first left end stitch.
- ② Insert the tapestry needle into the third stitch from the left and pass it back through the second stitch from the left. Repeat this until you reach the right side of the knitting and pass the tapestry needle through the right end stitch.
- ③ Take the waste knitting off. And the binding off is completed.

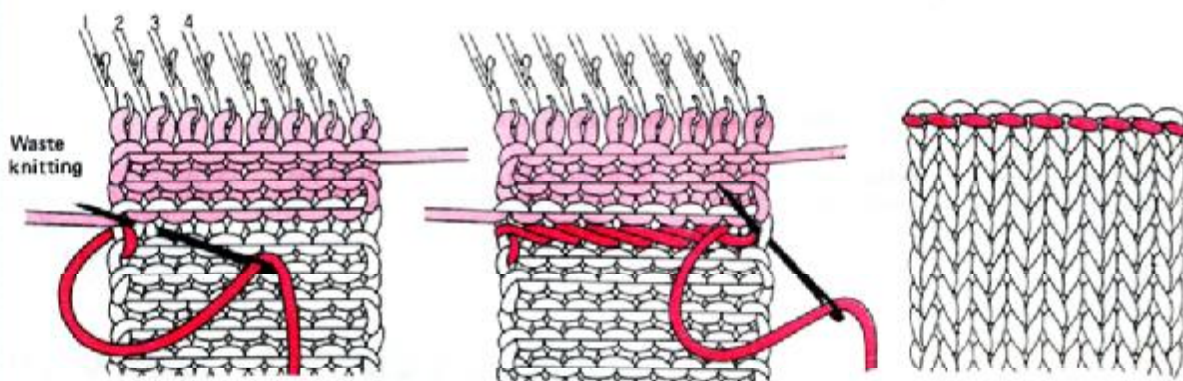

B) When the yarn is on the right side of the machine

※(Cut the main yarn leaving a length of three times the width of the knitting)

- ① Knit several rows with waste yarn after finishing the required length. Thread the main yarn into the tapestry needle, pass the tapestry needle through the second stitch from behind pulling it towards you. Insert the tapestry needle into the first right end stitch and pass it through the third stitch from the right, as shown in the diagram. (Making sure you pass the tapestry needle behind the second stitch and enter the third stitch from behind.)
- ② Repeat this until you reach the left side of the knitting and pass the tapestry needle through the left end stitch. Take the waste knitting off. And the binding off is completed.

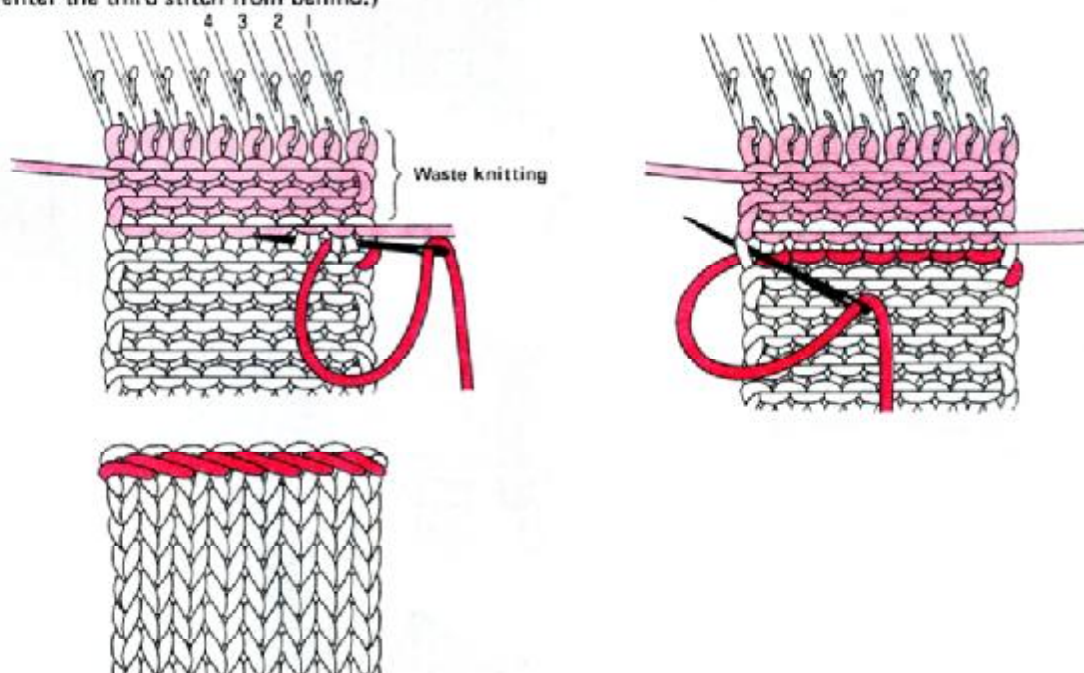

Binding off by using the latch tool

A) Method (1)

① Insert the latch tool into the right end stitch from behind, hook the yarn with the hook of the latch tool and pull it to make a new stitch.

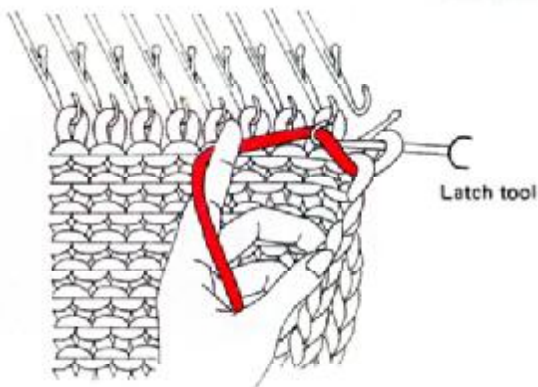

② Insert the latch tool into the second stitch from the right from behind and pass the two stitches behind the latch of the latch tool. Pull it to make a new stitch.

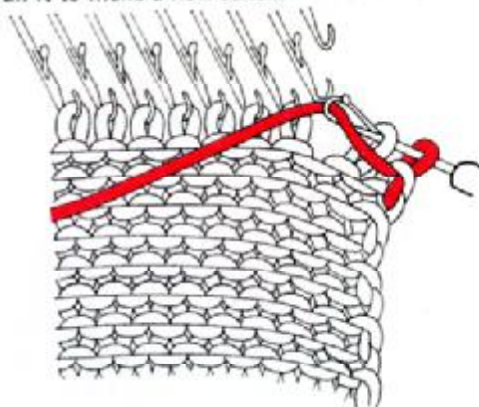

③ After binding off the required stitches, hook the stitch which is on the latch tool onto the hook of the needle. Continue knitting.

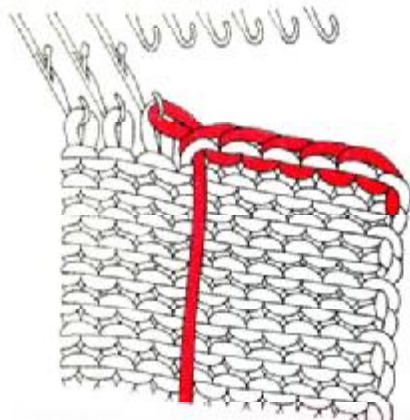

B) Method (2)

① Increase the tension dial four numbers higher than the main tension. And knit one row (last row). Insert the latch tool into the right end stitch and second stitch from the right, as shown in the diagram.

② Pull the latch tool until the right end stitch goes over the latch to make a new stitch.

③ Repeat this until you reach the last stitch, hook the end of the knitting yarn with the latch tool and pull it through the last stitch.

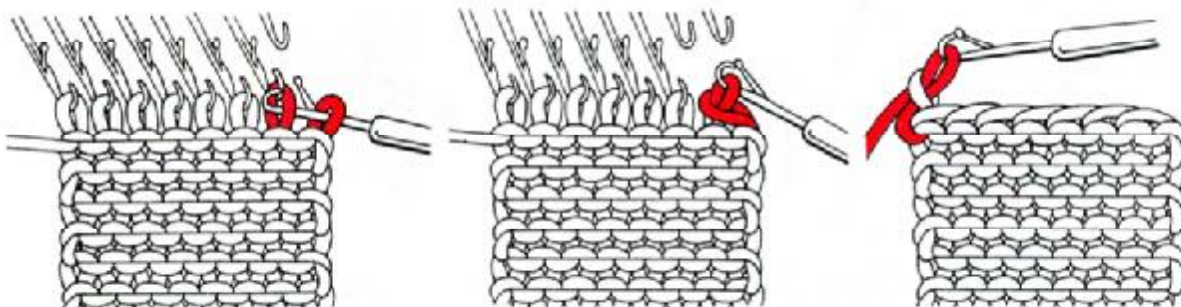

C) Method (3)

(Binding off the stitches after taking the stitches (swatch) off the machine)

- ① Increase the tension dial four numbers higher than the main tension and knit one row (last row). Knit one row with the cast-on thread and several rows with waste yarn, then take the stitches (swatch) off the machine.
- ② Hold the front side of the swatch facing you and fold the waste knitting towards you. Insert the latch tool into the end stitch and the second stitch from the end and pull it to make a new stitch, as shown in the diagram.

- ③ Repeat this until you reach the last stitch, hook the end of the knitting yarn with the latch tool and pull it through the last stitch.

3

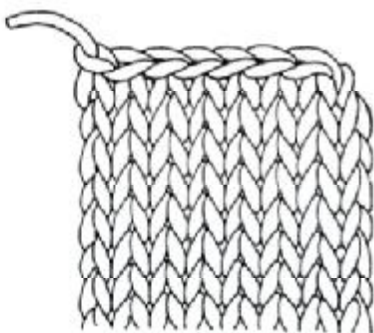
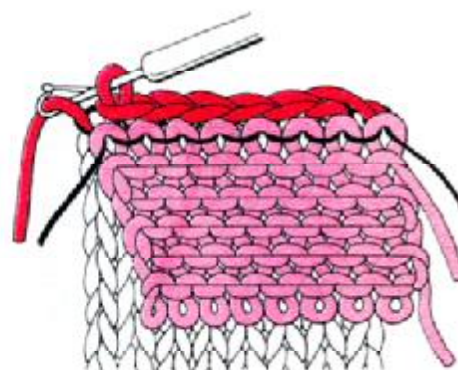
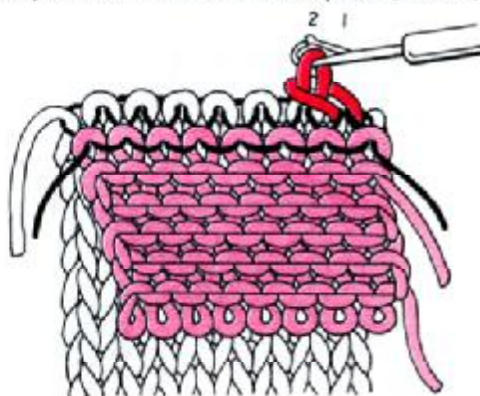

Cast-off edge (1×1 rib)

A) If the right end stitch on the front side of the swatch is a plain stitch

- ① After finishing the 1x1 rib, bring forward all the needles which have rib stitches to position 'E'.

- ② Push both 'PART' buttons and knit one row with waste yarn.

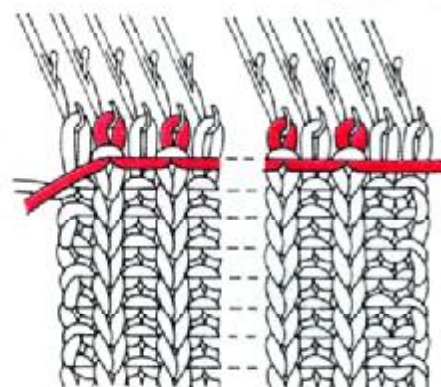
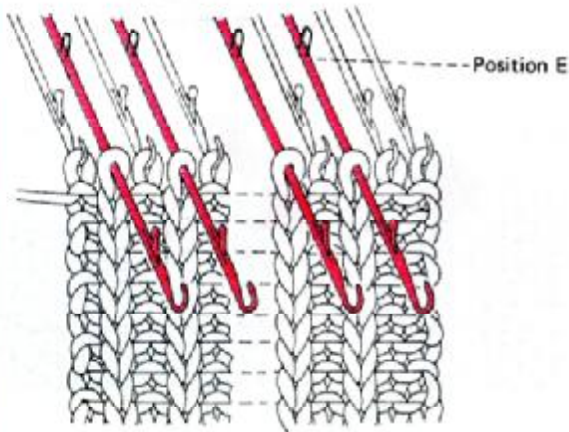

③ Cancel both 'PART' buttons and continue to knit with waste yarn. Take the swatch off the machine.

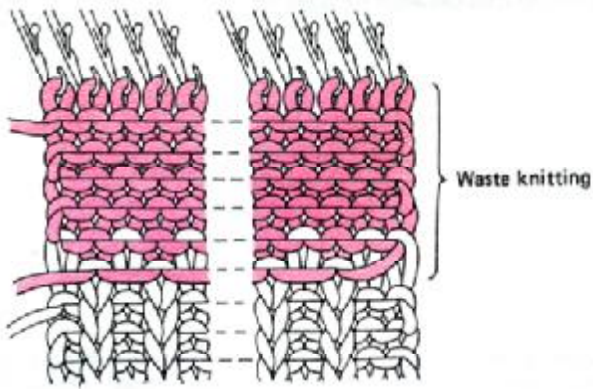

④ Hold the front side of the swatch facing you and fold the waste knitting towards you. Insert the tapestry needle into the first stitch from the front and pass it through the second stitch from the front.

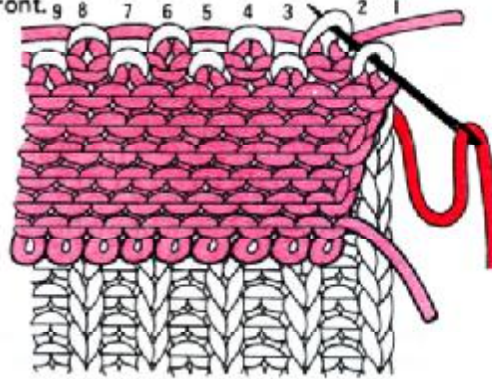

⑤ Insert the tapestry needle into the first stitch from the front and pass it through the third stitch from behind.

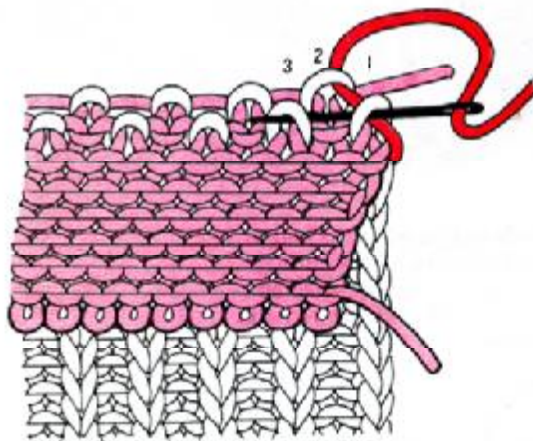

⑥ Insert the tapestry needle into the second stitch from behind and pass it through the fourth stitch from the front.

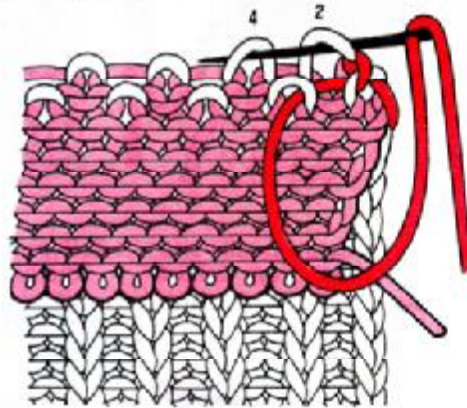

⑦ Repeat these steps ⑤ and ⑥ and at the end of the swatch, pass the tapestry needle through the two stitches, as shown in the diagram. Take the waste knitting off, the 1x1 rib binding off is completed.

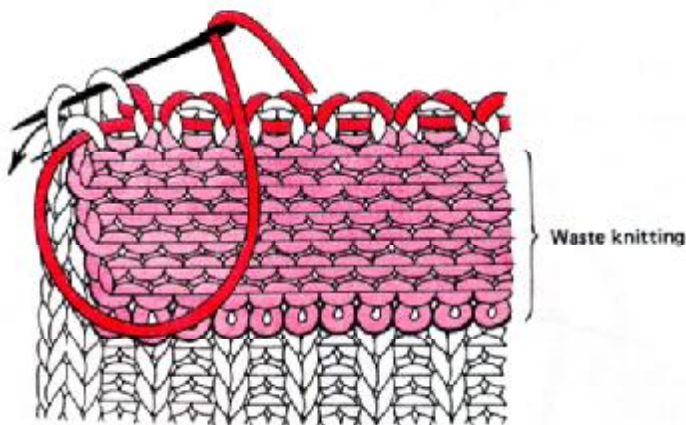

B) If the end two stitches on the front side of the swatch are plain stitches

※ Knit the waste knitting in the same manner as in item A) cast-off edge on page 24.

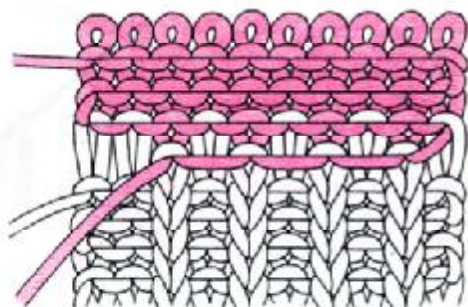

① Hold the front side of the swatch facing you and fold the waste knitting towards you. Insert the tapestry needle into the first stitch from the front and pass it through the second stitch from behind.

② Insert the tapestry needle into the first stitch from the front and pass it through the third stitch from the front.

③ Insert the tapestry needle into the second stitch from the front and pass it through the fourth stitch from behind.

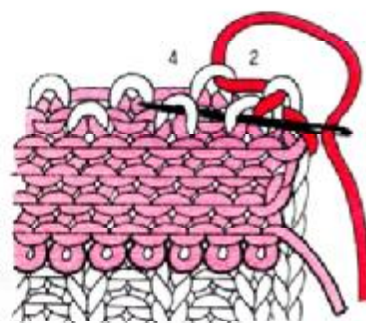
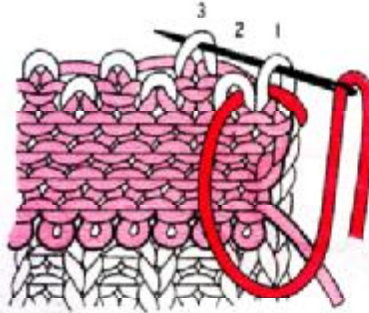
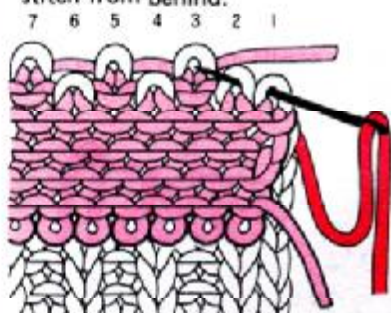

④ Insert the tapestry needle into the third stitch from behind and pass it through the fifth stitch from the front.

⑤ Repeat these steps ③ and ④ and at the end of the swatch, pass the tapestry needle through the end stitch, as shown in the diagram. Take the waste knitting off and the 1x1 rib binding off is complete.

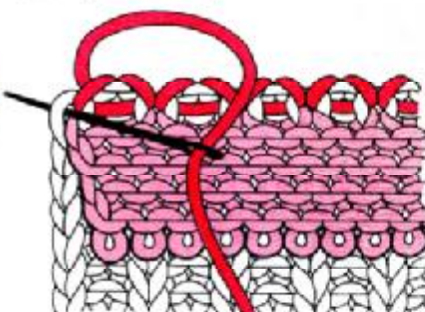
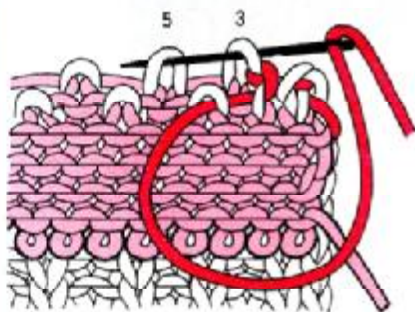

C) If the end three stitches on the front side of the swatch are plain stitches

※ Knit the waste knitting in the same manner as in item A) cast-off edge on page 24.

① Hold the front side of the swatch facing you and fold the waste knitting towards you. Insert the tapestry needle into the second stitch from behind and pass it through the first stitch from behind.

② Insert the tapestry needle into the second stitch from the front and pass it through the third stitch from behind.

③ Insert the tapestry needle into the first stitch from the front and pass it through the fourth stitch from the front.

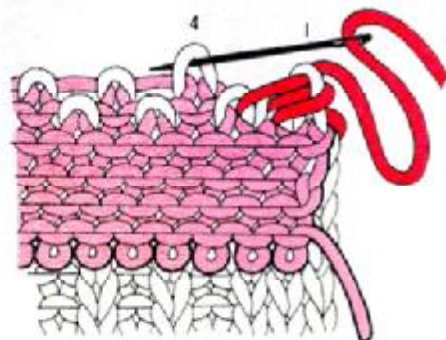
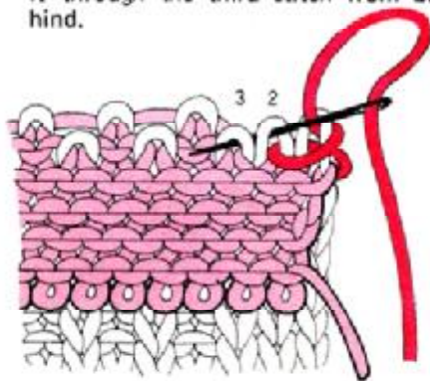
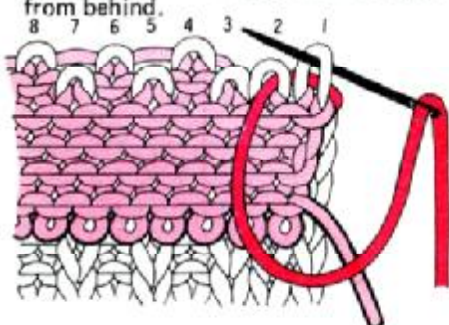

Repeat the same operation as in item ⑤-⑦ on page 25.

Cast-off edge (2×1 rib)

※Knit the waste knitting in the same manner as the 1x1 rib. (Refer to page 24)

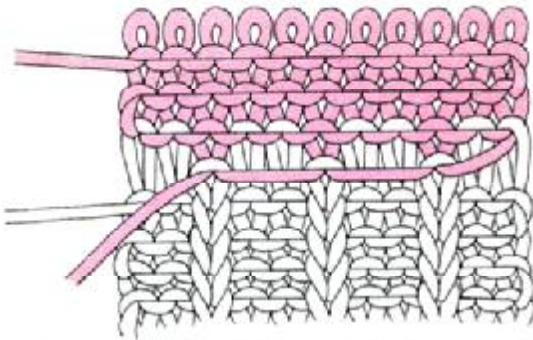

- ① Hold the front side of the swatch facing you and fold the waste knitting towards you. Insert the tapestry needle into the first stitch from the front and pass it through the second stitch from behind.

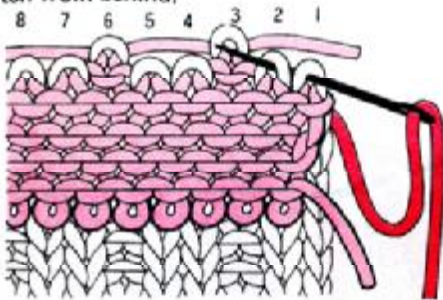

- ② Insert the tapestry needle into the first stitch from behind and pass it through the third stitch from the front.

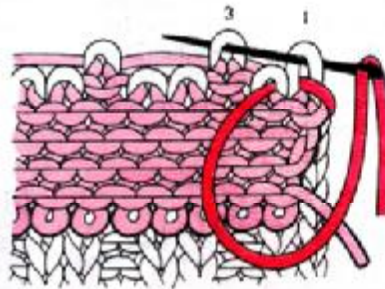

- ③ Insert the tapestry needle into the second stitch from the front and pass it through the fourth stitch from behind.

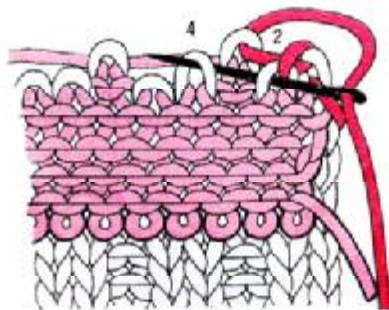

- ④ Insert the tapestry needle into the third stitch from behind and pass it through the fifth stitch from behind.

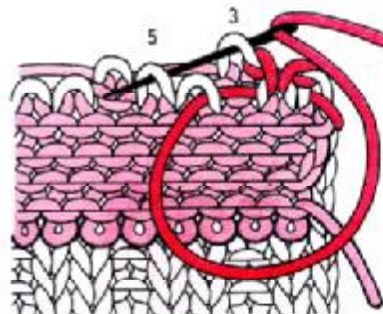

- ⑤ Insert the tapestry needle into the fourth stitch from the front and pass it through the sixth stitch from the front.

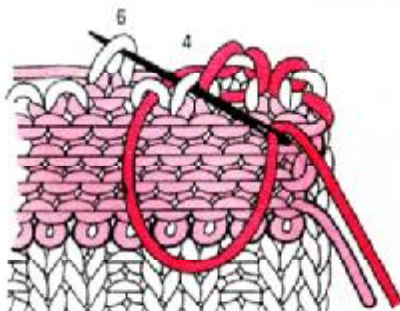

- ⑥ Repeat these steps ③-⑤ and at the end of the swatch pass the tapestry needle through, as shown in the diagram.

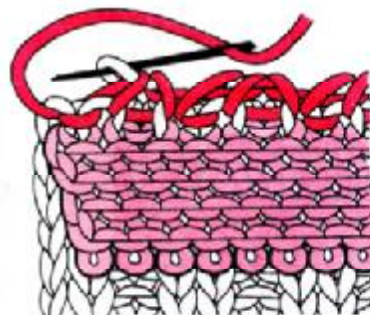

Cast-off edge (2×2 rib)

※Knit the waste knitting in the same manner as the 1x1 rib. (Refer to page 24)

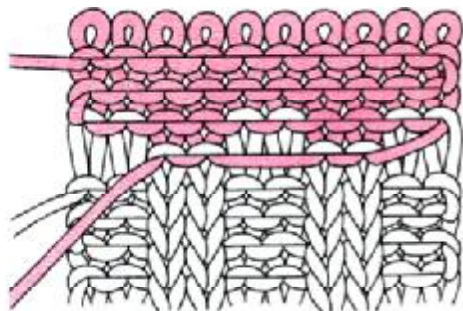

A) If the end two stitches on the front side of the swatch are plain stitches

① Hold the front side of the swatch facing you and fold the waste knitting towards you. Insert the tapestry needle into the first stitch from the front and pass it through the second stitch from behind.

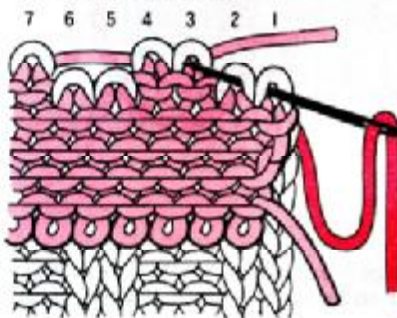

② Insert the tapestry needle into the first stitch from the front and pass it through the third stitch from the front.

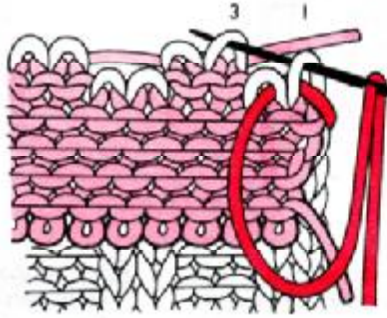

③ Insert the tapestry needle into the second stitch from the front and pass it through the fifth stitch from behind.

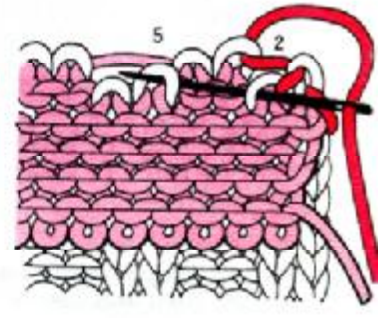

④ Insert the tapestry needle into the third stitch from behind and pass it through the fourth stitch from the front.

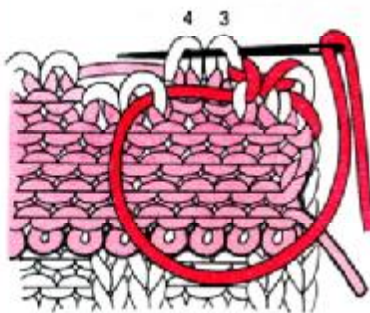

⑤ Insert the tapestry needle into the fifth stitch from the front and pass it through the sixth stitch from behind.

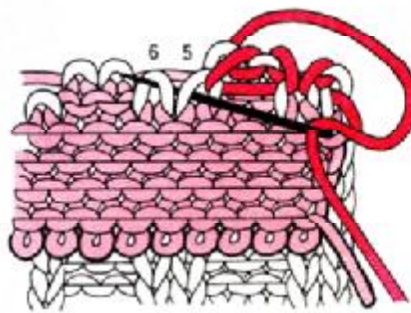

⑥ Insert the tapestry needle into the fourth stitch from behind and pass it through the seventh stitch from the front.

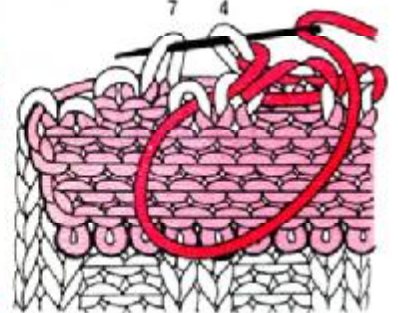

⑦ Repeat these steps ③ - ⑥ and at the end of the swatch, pass the tapestry needle through the stitches as shown in the diagram.

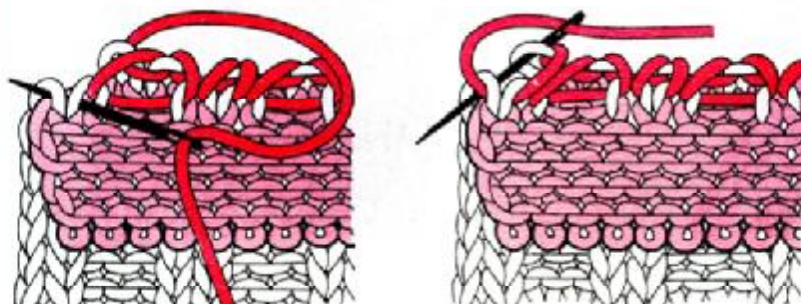

B) If the end three stitches on the front side of the swatch are plain stitches

- ① Hold the front side of the swatch facing you and fold the waste knitting towards you. Pass the tapestry needle through the first, second and third stitches from behind as shown in the diagram.
- ② Pass the tapestry needle back through the second and first stitches as shown in the diagram.
- ③ Insert the tapestry needle into the fourth stitch from the front, pass it through the third stitch from the front and the sixth stitch from behind.

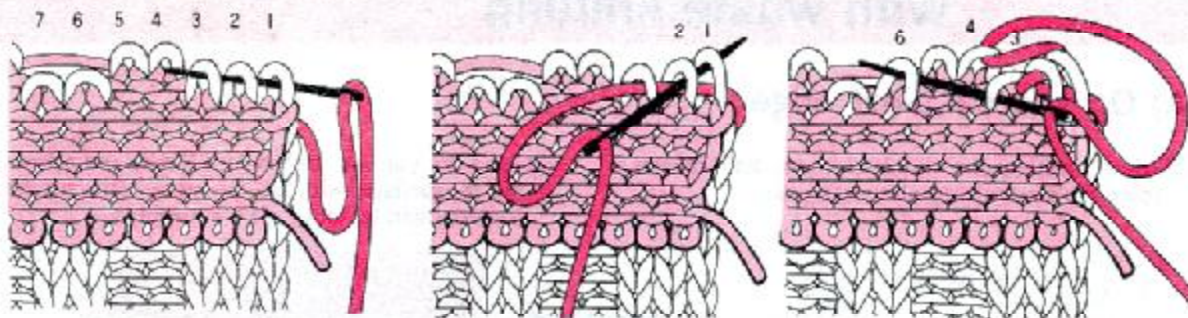

- ④ Insert the tapestry needle into the fourth stitch from behind and pass it through the fifth stitch from the front. Repeat the same operation as item A) — ⑤, ⑥, ③ and ④ on page 28.
- ⑤ At the end of the swatch, pass the tapestry needle through the stitches as shown in the diagram.

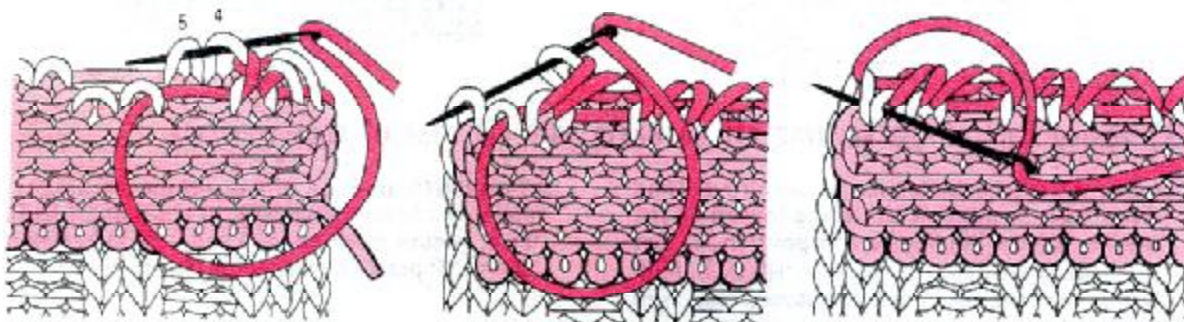

Drawing up yarn

(Take off on waste yarn after finishing the main knitting)

- ① Thread the yarn into the tapestry needle and insert it into every other stitch of the last row of knitting.
- ② Turn back the tapestry needle to the starting side and insert it into all the stitches of the last knitted row as shown in the diagram.

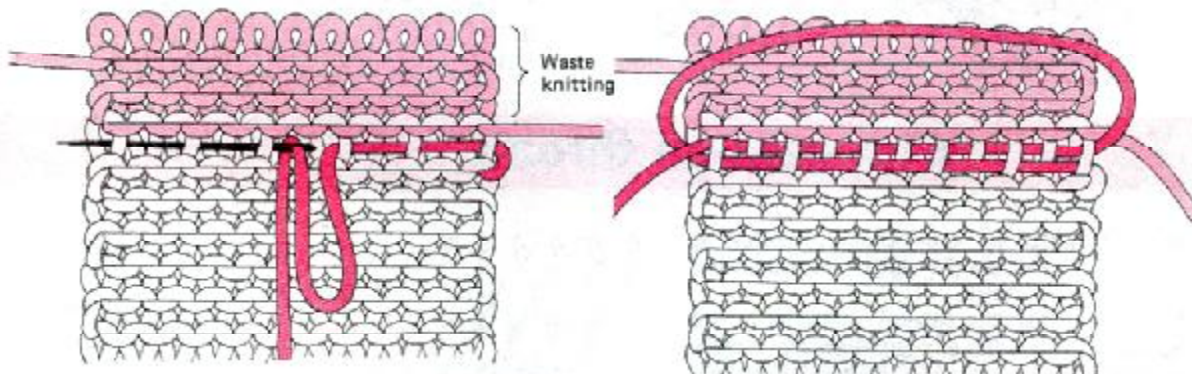

- ③ Draw the yarn up.



4 TAKING OFF THE STITCHES (SWATCH)

With waste knitting

A) On the cast-off edge

① After knitting the required rows, knit several rows in plain knitting with waste yarn.

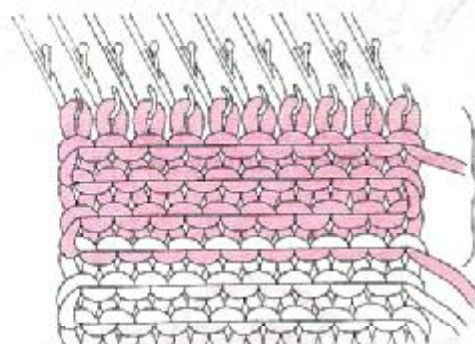

Waste knitting
Waste knitting

② Take the yarn out of the yarn feeder and operate the K carriage without the yarn. The stitches (swatch) will be taken off the machine.

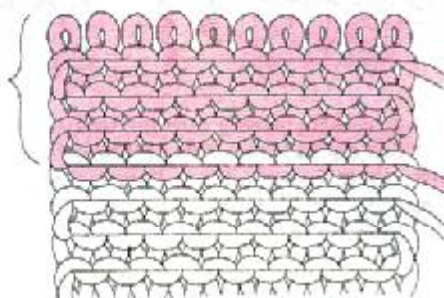

B) Taking part of the knitting off on waste yarn (In case of neck shaping)

① Leave the stitches which are to be knitted off on waste yarn in position 'B'. Bring forward all the needles for the holding part to position 'E'. Set the holding cam lever to position 'H', (N.B. Push button machine to II) and knit several rows with waste yarn.

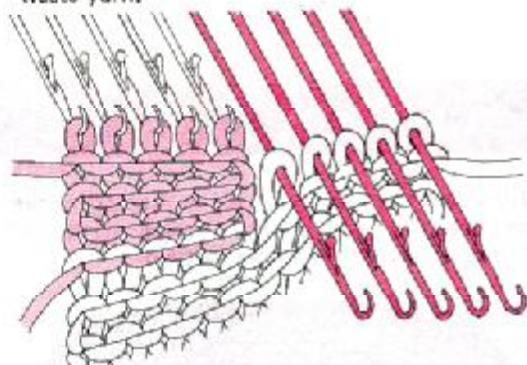

② Take the 'B' position stitches off the machine. Reset the holding cam lever to position 'N' (N.B. Push button machine to I) and continue to knit all the 'E' position needles for the knitting part.

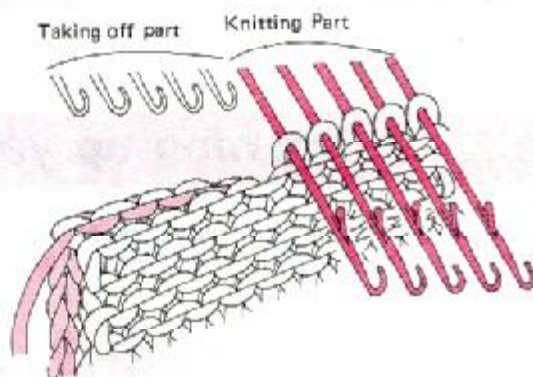

With cast-on thread

Bring forward all the holding needles to position 'E' and lay the cast-on thread on the hooks of the needles.

Make sure that the cast-on thread is in the hooks of the needles and push back the needles one by one to position 'A' by hand. Continue to knit all the needles for the knitting part.

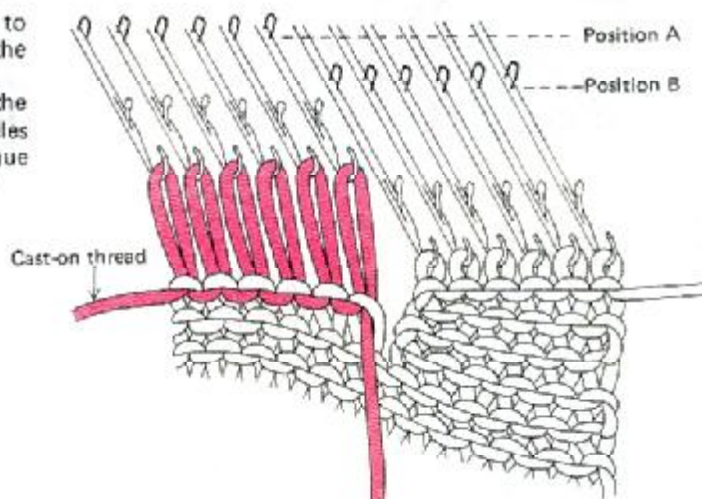

5 Picking up Stitches

Returning stitches to machine by picking up the last row of knitting

A) From the front side

① Knit several rows with the waste yarn and take them off the machine.

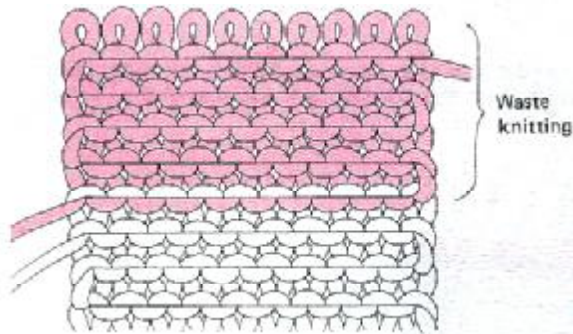

② Hold the front side of the swatch facing you and fold the waste knitting towards you. Pick up the last row of knitted loops, and hook them onto the hooks of the needles.

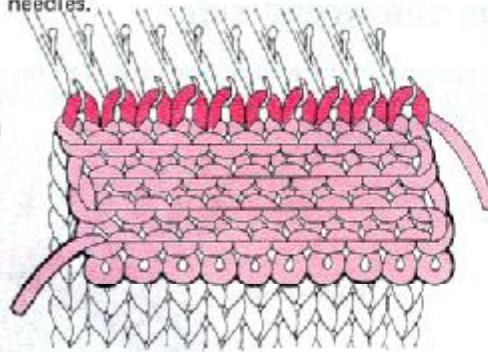

Hold the swatch with left hand and pick up the stitches

B) From the wrong side

① Hold the wrong side of the swatch facing you and fold the waste knitting towards the machine. Pick up the last row of knitted loops and hook them on to the hooks of the needles.

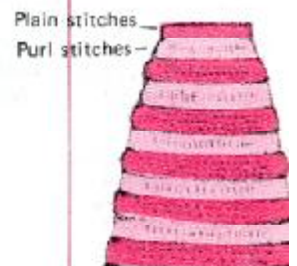
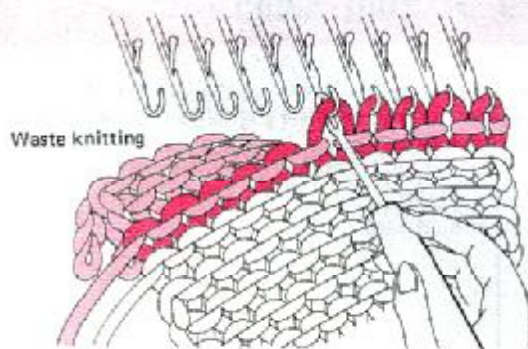

Plain stitches
Purl stitches

Returning stitches to machine by picking up first row of knitting

A) From the front side

① Hold the front side of the swatch facing you and pick up the first row of knitted loops and hook them onto the hooks of the needles.

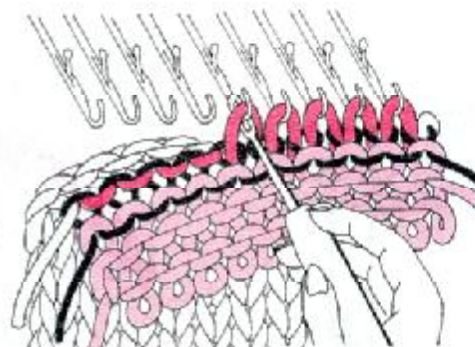
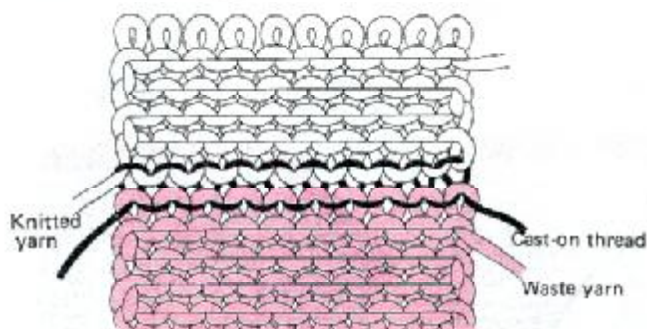

② It will be one stitch less on the edge you pick up, than the waste yarn edge. Therefore, it is necessary to pick up a stitch from the edge of the swatch.

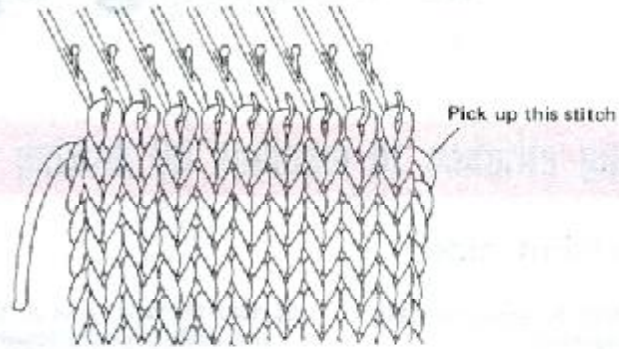

B) From the wrong side

Hold the wrong side of the swatch facing you, pick up the first row of knitted loops and hook them onto the hooks of the needles. It is necessary to pick up a stitch from the edge of the swatch as you will find you are one stitch less again.

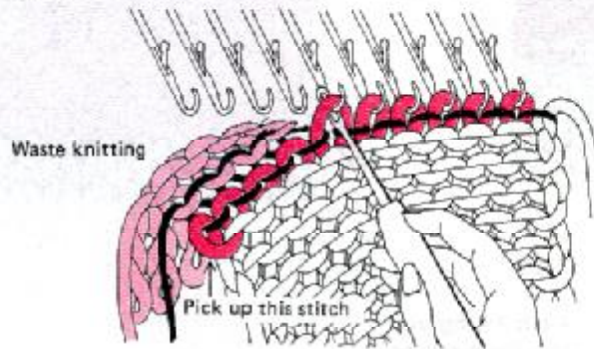

Pick up the side edge stitches (In case of front band)

N.B.

When picking up the edge of a garment always pick up the end loops first. Then find the centre loop and place this onto the centre needle, continue working using this method until all stitches are evenly placed on all needles, as shown in the diagram.

If picking up an elasticated band i.e. 1x1 or 2x2. Remember to add 5% or 10% more needles (as the band will shrink when taken off the machine).

Pick up the stitches for the front opening equally and hook them onto the hooks of the needles. If you use the stitch measure scale of the certain tension gauge, you can find the necessary stitches for the front border from the scale. (N.B. Stitch measure scale found in knit-leader).

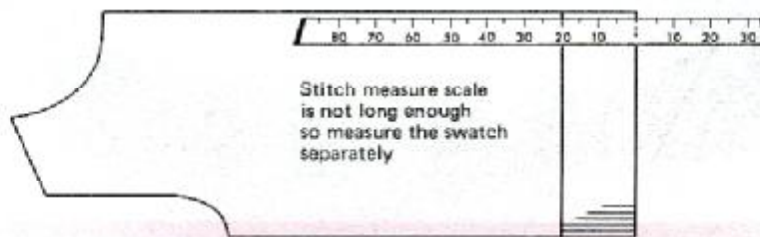

A) From the front side

Hold the front side of the swatch facing you, pick up the edge stitches with the transfer tool and hook them onto the hooks of the needles.

B) From the wrong side

Hold the wrong side of the swatch facing you, pick up the edge stitches with the transfer tool and hook them onto the hooks of the needles.

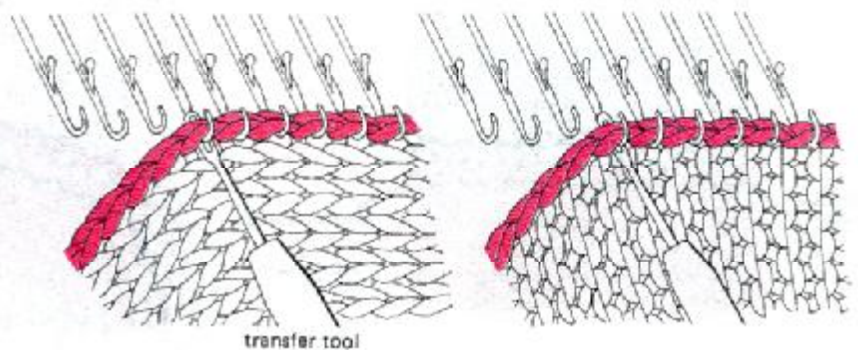
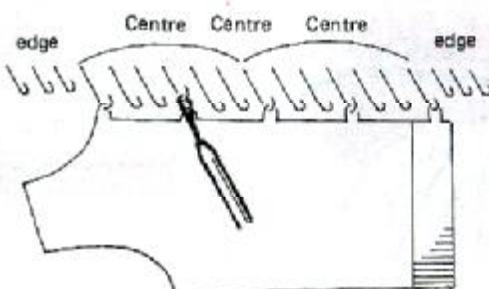

Pick up neck line stitches

To find the necessary stitches for the neck line, place the stitch measure scale along the neck line. Pick up the neck line stitches equally and hook them onto the hooks of the needles.

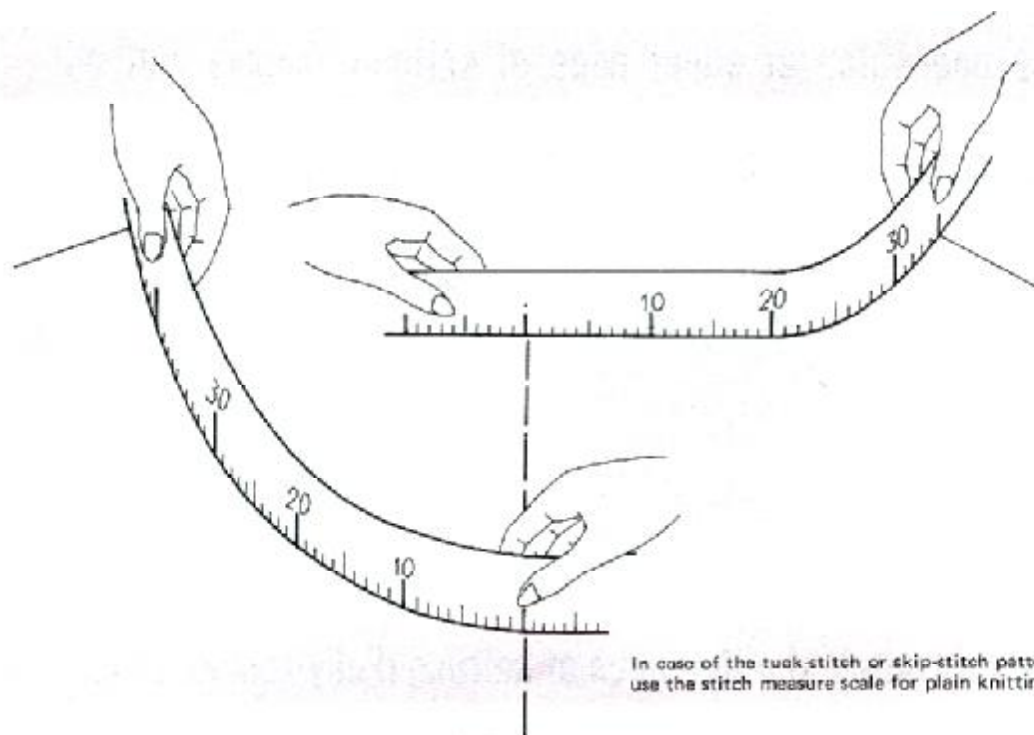

N.B.

If picking up an elasticated band i.e. 1x1 or 2x2. Remember to add 10% or 15% more needles (as the band will shrink when taken of the machine).

If using a plain stitch for the band. Remember to reduce the needle selection by approximately 5%.



A) Using the front side

Hold the wrong side of the swatch facing you, pick up the edge stitches at the neck line and hook them onto the hooks of the needles.

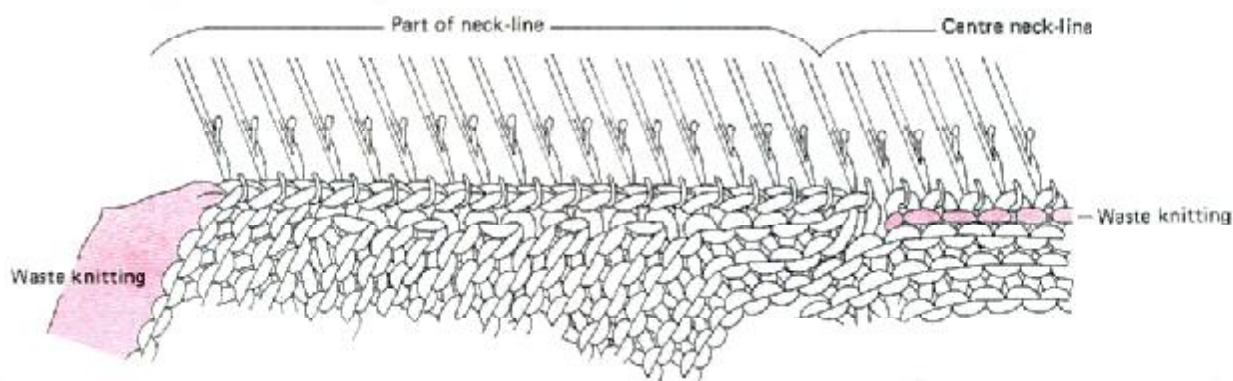

B) Using the wrong side

Hold the front side of the swatch facing you, pick up the stitches which are behind the stitches at the edge neck line and hook them onto the hooks of the needles as shown in the diagram.

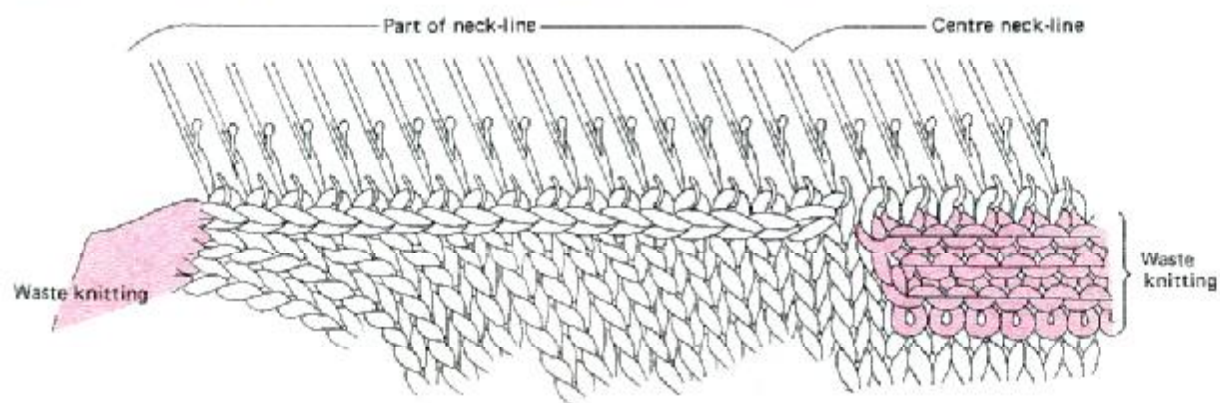

6 Increasing

Increase one stitch at either edge of knitting (Simple method)

① On the K carriage side, push one needle into working position B from position A.

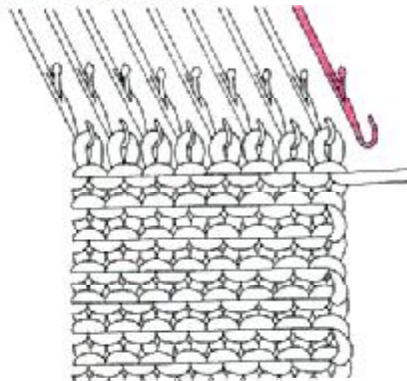

② Operate the K carriage and knit one row. You can do this method on the K carriage side only. When you increase one stitch on the both sides, do the same operation on the other side after operating the K carriage to the opposite side.

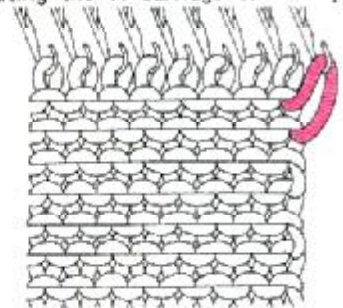

6



Increase one stitch at either edge of knitting (Fully-fashioned method 1)

① Using the transfer tool, transfer the edge stitch to the adjacent outside empty needle. (The second needle becomes empty.) Pick up the needle loop on the lower row of the second stitch from the end.

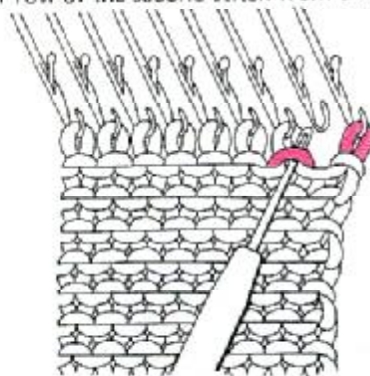

② Hook the needle loop onto the empty second needle from the end as shown in the diagram.

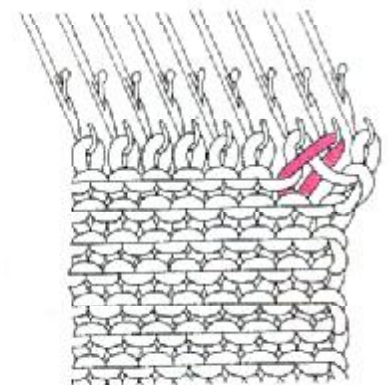

Increase one stitch at either edge of knitting (Fully-fashioned method 2)

① Using the transfer tool, transfer two stitches on the edge to the adjacent outside empty needles, as shown in the diagram. (The third needle becomes empty.) Pick up the needle loop on the lower row of the third stitch from the end.

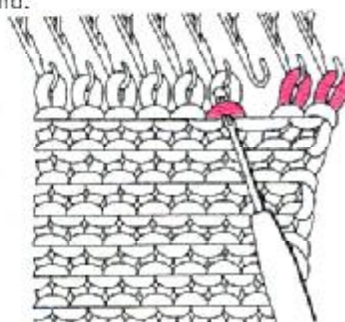

② Hook the needle loop onto the empty third needle from the end as shown in the diagram.

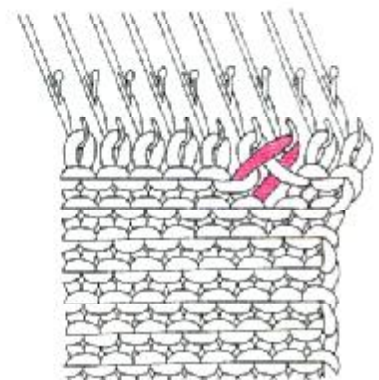

Increasing evenly

① Knit up to the increasing point, take the stitches (swatch) off the machine with waste knitting. Calculate the increasing stitches. Pick up the stitches by missing stitches at certain intervals.

② Using the transfer tool, pick up the needle loops on the lower row of the adjacent empty needles and hook them onto the empty needles. As shown in the diagram.

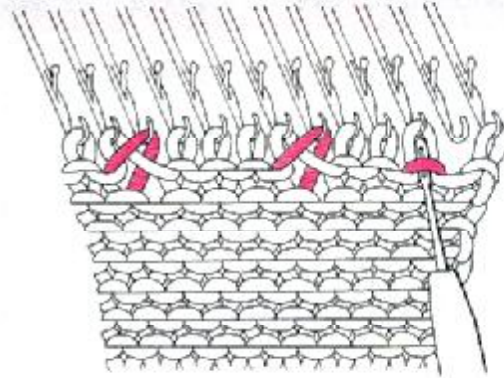
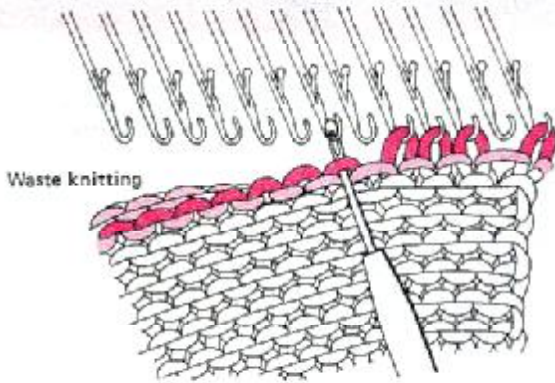

Increase several stitches at either side of the knitting

① On the K carriage side, bring forward the needles to be increased to position E from position A. Starting with the inside needle, loop the yarn around the needles and pass it under the end needle as shown in the diagram.

② Knit one row. ※ Push the needles with the increased stitches to position E and knit another row. ※ Repeat from asterisk to asterisk for the next few rows.

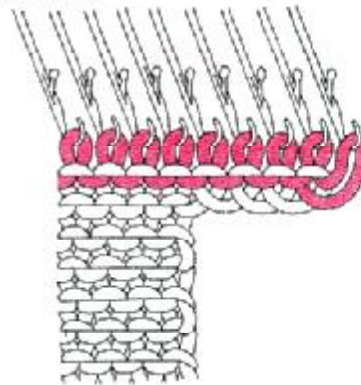
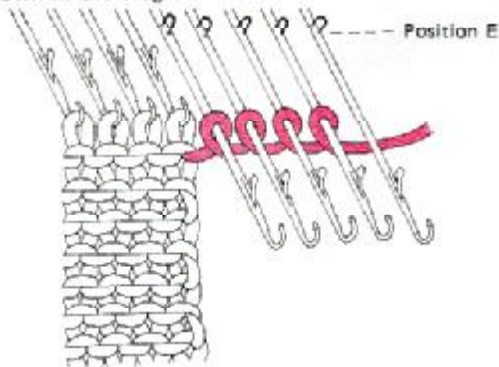

7 Decreasing

Decrease one stitch at either edge of the knitting

A) Simple method

① Take the end stitch off the needle with the transfer tool.

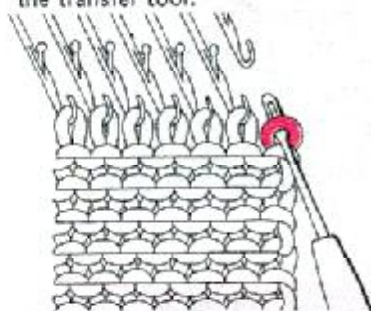

② Hook the transfer tool into the adjacent inside needle and transfer the stitch onto the hook. Return the empty needle to position A.

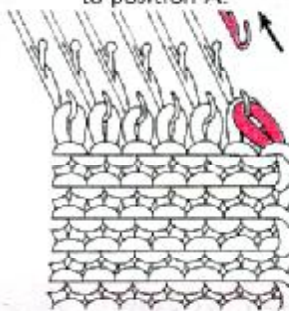

B) Fully-fashioned method (1)

① Take the end two stitches off the needles with the transfer tool.

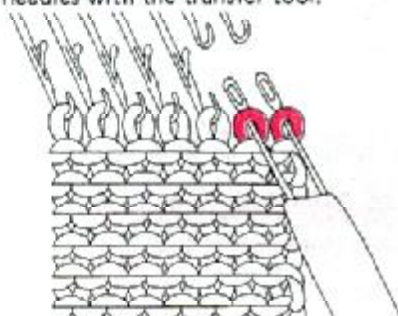

② Hook the transfer tool to the adjacent inside needle and transfer the two stitches to the hook of them. Return the empty needle to position A. As shown in the diagram.

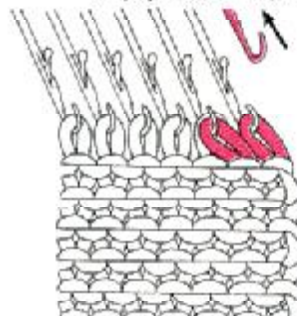

C) Fully-fashioned method (2)

① Take the end three stitches off the needles with the transfer tool.

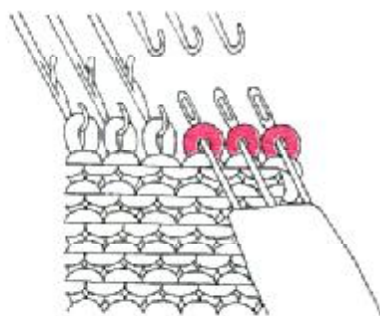

② Hook the transfer tool to the adjacent inside needle and transfer the three stitches to the hook of them. Return the empty needle to position A.

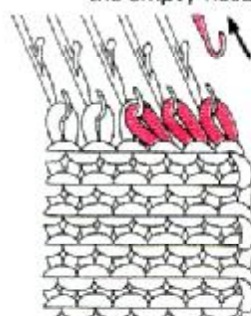

D) Fully-fashioned method (3)

① Using the transfer tool, transfer the second stitch from the end to the end needle. (End needle has two stitches.)

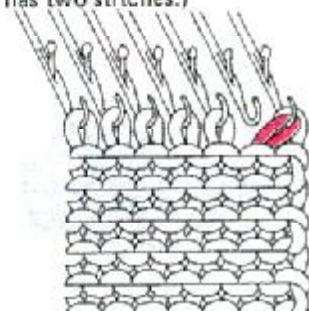

② Take the two stitches off the needle with the transfer tool.



③ Hook the transfer tool to the inside empty needle and transfer the two stitches to the hook of it. Return the empty needle to position A.

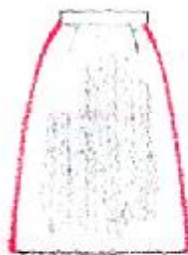
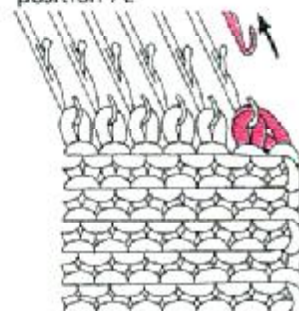

E) Fully-fashioned method (4)

① Using the transfer tool, transfer the third stitch from the end to the second needle from the end. (Second needle has two stitches.)

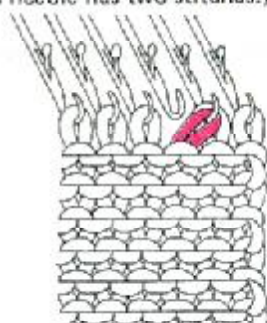

② Take the three stitches off the needles with the transfer tool. Hook the transfer tool to the adjacent inside needle and transfer the three stitches to the hook of them. As shown in the diagram.

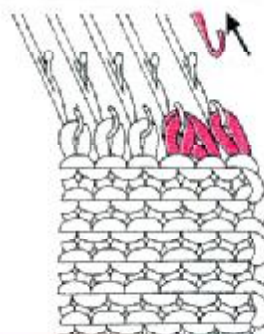
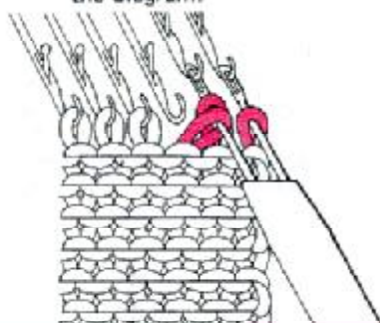

Decrease two stitches at either side of the knitting

A) Fully-fashioned method (1)

① Using the transfer tool, transfer the fourth and fifth stitches to the sixth and seventh needles as shown in the diagram.

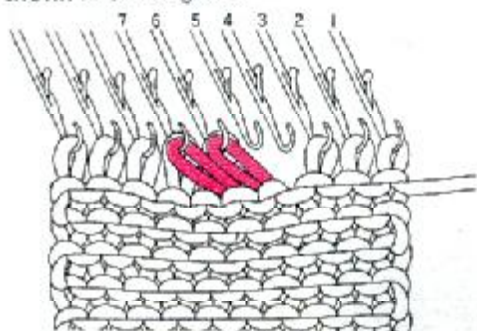

② Transfer the end three stitches to the inside with the transfer tool as shown in the diagram. Return the two empty needles to position A.

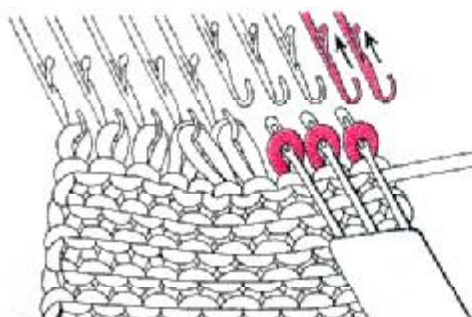

N.B.

This method of seaming is used with method (1).



This method of seaming is used with method (2).

B) Fully-fashioned method (2)

① Using the transfer tool, transfer the second and third stitches to the fourth and fifth needles as shown in the diagram. Transfer end stitch to the inside with the transfer tool as shown in the diagram, and return the empty needles to position A.

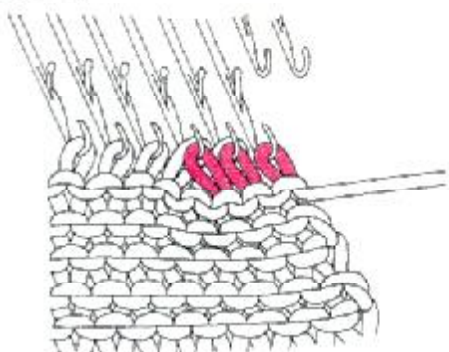

C) Fully-fashioned method (3)

① Using the transfer tool, transfer the seventh and sixth stitch to the fifth and fourth needles as shown in the diagram.

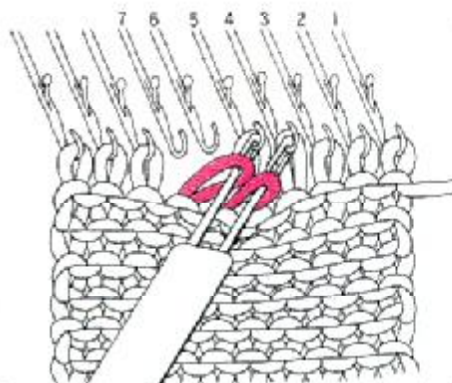

② Transfer the stitches which are on the fifth and fourth needles to the sixth and seventh needles with the transfer tool as shown in the diagram.

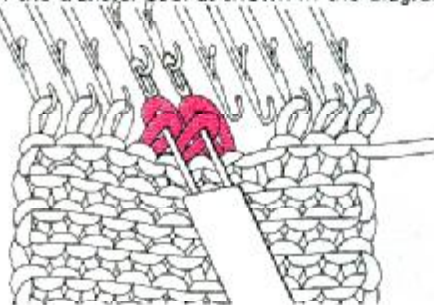

③ Transfer the end three stitches to the inside as shown in the diagram. Return the empty two needles to position A.

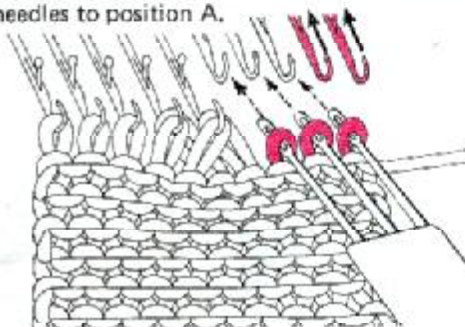

Decrease several stitches at either side of the knitting

A) At the same side of the K carriage

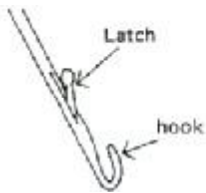

① Transfer the end stitch to the adjacent inside needle and return the empty needle to position A.

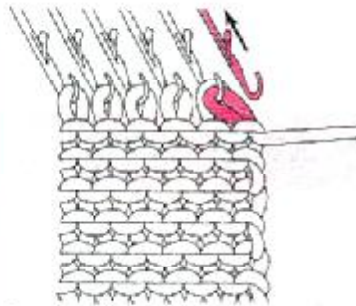

② Bring forward the needle with the two stitches so that the stitches fall behind the needle latch. Place the yarn in the needle hook and push back the needle manually to make a single stitch.

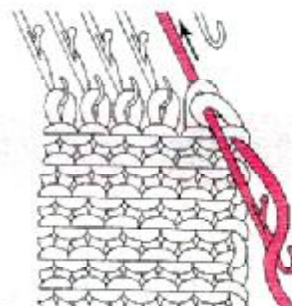

③ Now, one stitch is decreased.

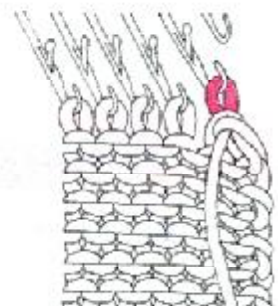

④ Transfer the end stitch to the adjacent inside needle and return the empty needle to position A.

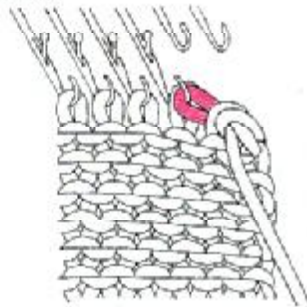

⑤ Repeat these steps ②-④, and decrease the necessary stitches. After decreasing the stitches, hook the end stitch to the adjacent inside needle. (No need to make a single stitch.)

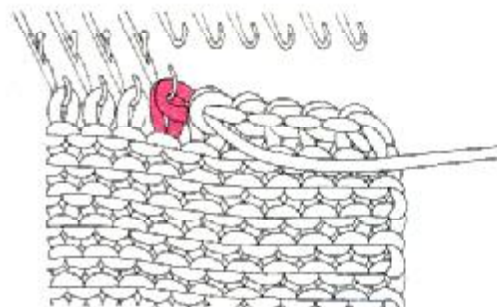

B) At the opposite side of the K carriage

① Transfer the second stitch from the end to the end needle.

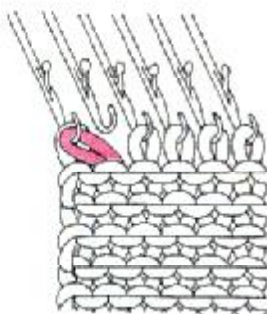

② Transfer the two stitches which are on the end needle to the adjacent inside needle and return the empty needle to position A.

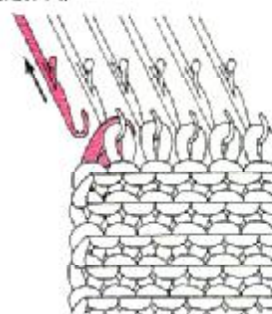

③ Pass the end stitch over the needle latch and push back the needle manually to make a single stitch.

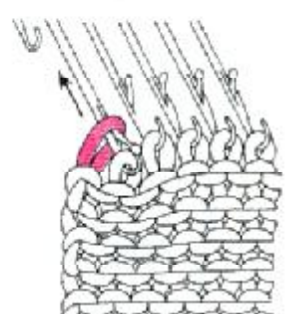

④ Now, one stitch is decreased.

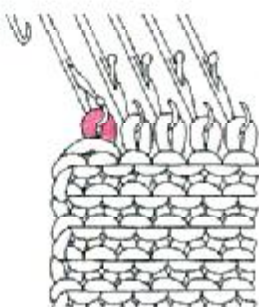

⑤ Repeat these steps ①-④, and decrease the necessary stitches. After finishing the decreasing, there is no need to make a single stitch.

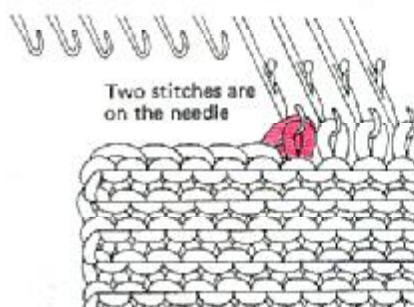

7



N.B. When decreasing more than three stitches at the opposite side of the K carriage, the decreasing tends to be a little tight, therefore, to eliminate this bring forward a new needle to position 'B' one row before, this can be used as a wool allowance.

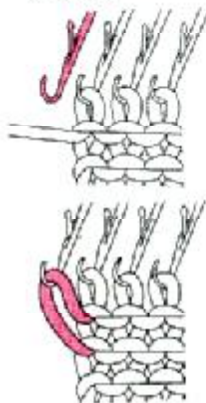

Decreasing evenly

(This method is used for making a round yoke, etc.)

A) With waste knitting

Knit up to the decreasing point and take the swatch off the machine with waste knitting. Calculate the decreasing stitches. Pick up the stitches by over lapping the stitches at certain intervals as shown in the diagram.

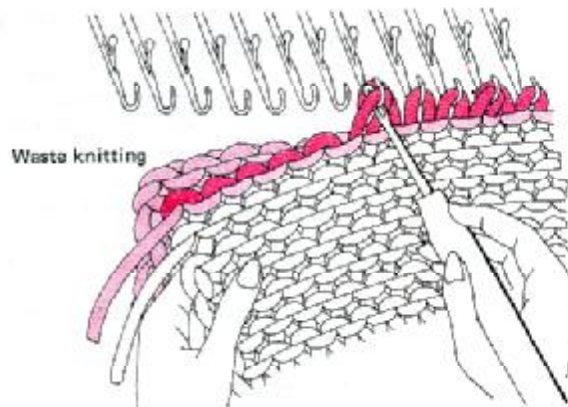

B) With L carriage

① Calculate the decreasing stitches and select the needles which are to be decreased to position D as shown in the diagram.

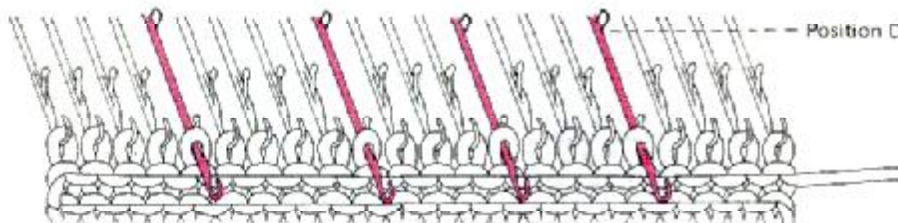

② Operate the L carriage so that the stitches transfer to the adjacent needles. Return the empty needles to position A.

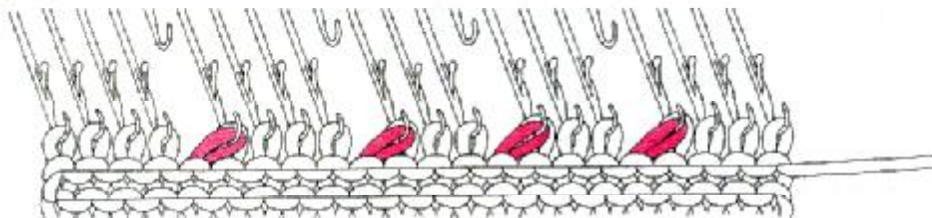

③ Knit several rows with waste yarn and take the swatch off the machine.

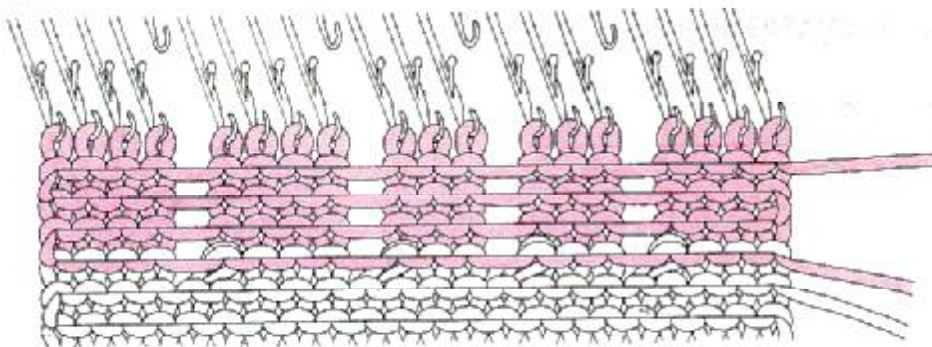

④ Hold the wrong side of swatch facing you and fold the part knitted with the waste yarn towards the machine. Pick up the stitches and hook them onto the hooks of needles as shown in the diagram.

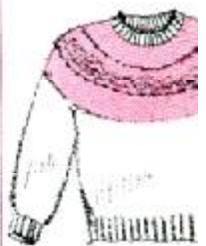
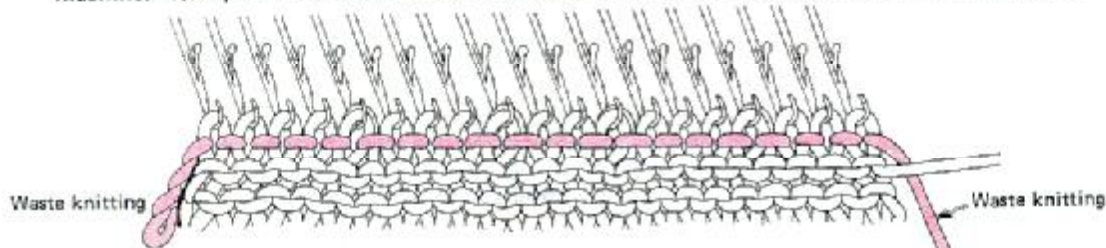

8 Example of Decreasing

V-neck collar

- FRONT NECK LINE
- △ BACK NECK LINE
- FRONT CENTRE NECK LINE

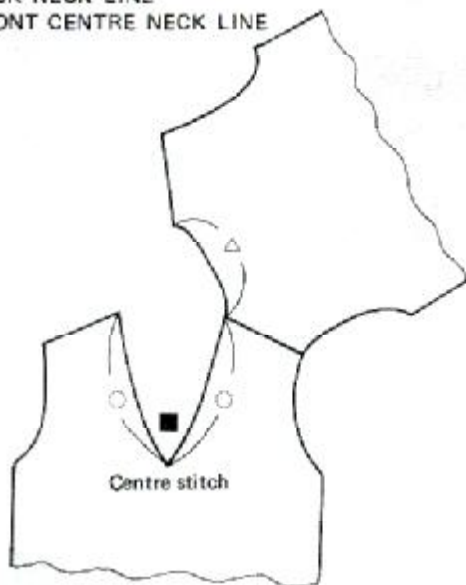

Cast-on edge for the V-neck collar with three stitches together and multi-transfer the stitches. (o/////△)

1x1 rib Start to knit with the odd number needles and make a complete stitch at the centre of the front neck line.

2x2 rib Start to knit with the even number needles and make two complete stitches at the centre of the front neck line.

Pick up the edge stitches of the neck line.

- ① Pick up the edge stitches after seaming the right side shoulder.
- ② Using the stitch measure scale, find the required number of stitches for the neck line and bring forward the same number of needles to position B.
- ③ At first, pick up the stitches for the front centre neck line stitch, both ends stitches, neck-point stitch and back centre neck line stitches as shown in the diagram. Then, pick up all the edge stitches for the neck line evenly.

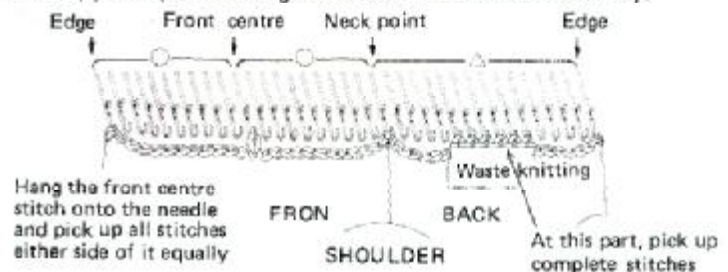

※ If the band is made up of rib stitches, add 5%–10% more needles to the required number of stitches

A) Decreasing the stitches on every row (55° – 60°)

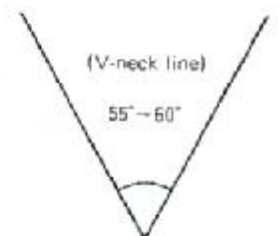
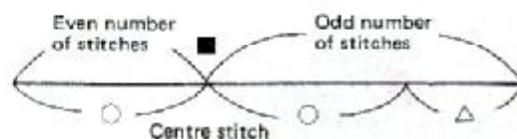

B) Decreasing the stitches on every row and on every other row alternately (75° – 80°)

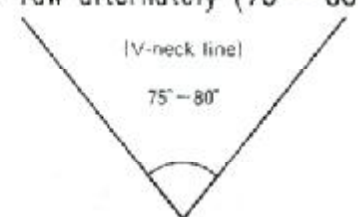
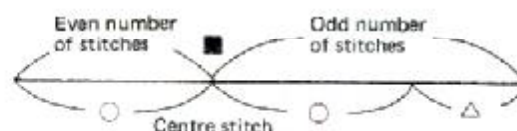

C) Decreasing the stitches on every other row (95° – 100°)

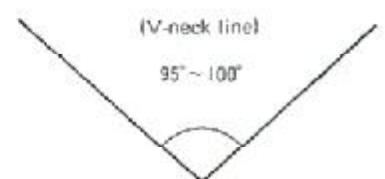
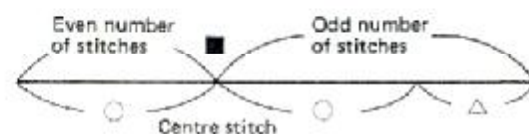

※ According to the neck line shaping, select and use the suitable method from the above three (angle). Reduce the tension dial by one number lower than the tension used when knitting the first row of the rib. Explanation of these three methods of decreasing by using the 1x1 rib knitting (Length of the collar is 3cm – 13 rows) can be found on the following pages.

Three stitches together and multi-transfer stitches

A) Decreasing the stitches on every row

① Pick up the edge stitches at the neck line, as shown in the diagram. And knit two rows.

② Transfer both side stitches of the front centre neckline to the front centre needle, as shown in the diagram. (O A O)

Left front neck line ————— Right front neck line + Back neck line

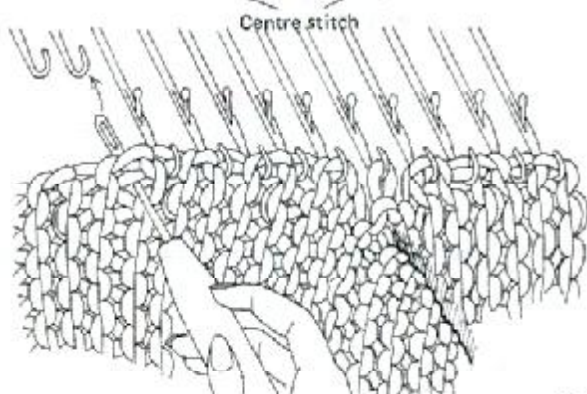

③ Transfer the three stitches which are on the front centre needle to the adjacent right needle, and all the stitches on the left side of the front centre needle to the right, as shown in the diagram. (O /// A III)

④ Knit one row and change the three purl stitches at either side of the front centre needle to plain stitches, then transfer these plain stitches on either side of the front centre needle to the front centre needle. (O A O) And transfer all the stitches to the right, as shown in the diagram. (O /// A III) Knit one row.

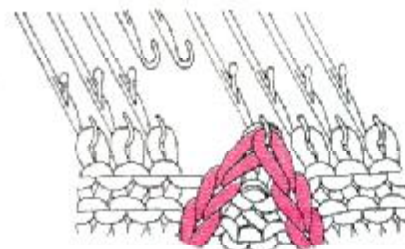
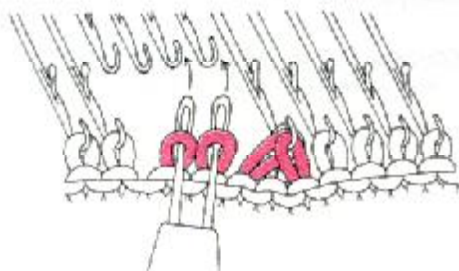

⑤ Repeat steps ②-④

⑥ At step ④ change all the Purl stitches either side of the front centre needle to plain stitches, starting at the edge each time.

⑦ On the twelfth row, transfer the three stitches which are on the front centre needle to the right and knit the thirteenth row from the right. Change the purl stitches on both sides of the front centre needle to plain stitches.

⑧ Now, decreasing is completed.

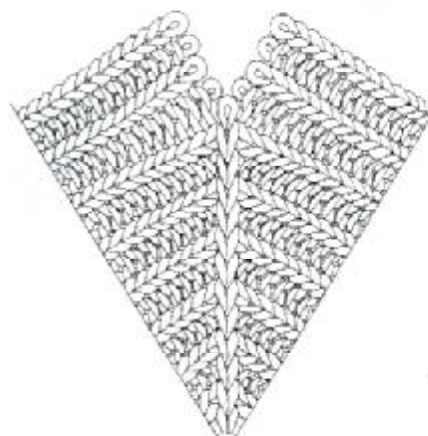

After transferring the stitches, it is better to bring the front centre needle forward to position E.

In case the collar is as long as 11 or 12 rows.

In the row of '●' mark, change both stitches either side of the front centre needle to plain stitches and transfer these to the front centre needle.

Make three stitches together and multi transfer stitches in the row of this A mark.

In case of 11 rows

In case of 12 rows

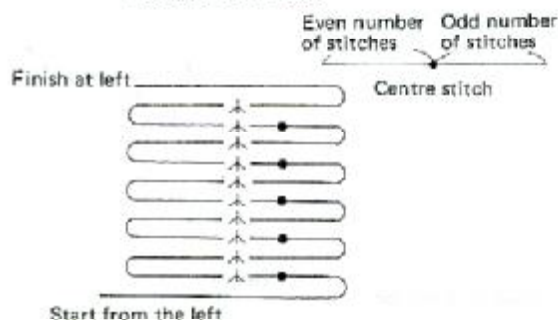
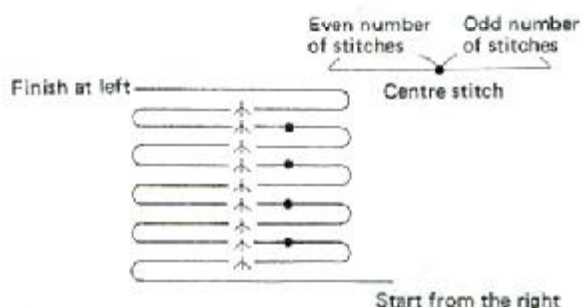

6) Decreasing the stitches on every row and on every other row alternately

- ① Pick up the edge stitches of neck line in the same manner as item A) on page 41.
- ② Knit two rows from the right and change the two purl stitches at either side of the front centre needle to plain stitches. Transfer these two stitches to the front centre needle and transfer all the stitches on the left side of the front centre needle to the right. (O A O) (O /// A IIII)

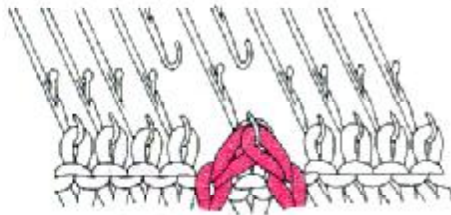

- ③ Knit one row and transfer both stitches either side of the front centre needle onto the front centre needle. (O A O)
Transfer all the stitches on the left side of the front centre needle to the right. (O /// A IIII)

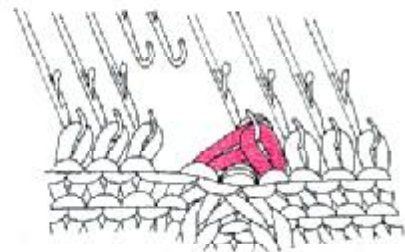

- ④ Knit two rows and change the three purl stitches either side of the front centre needle to plain stitches, then transfer them to the right. (O A O) (O /// A IIII)

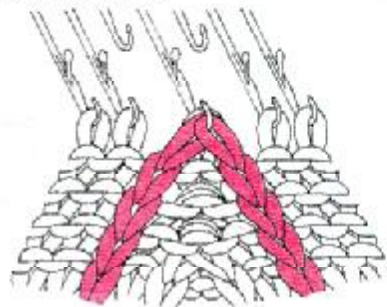

- ⑤ Repeat these steps ②-④ and make three stitches together and multi-transfer stitches on the twelfth row. Then, knit the thirteenth row from the right.

- ⑥ Change the stitches on both sides of the front centre needle to plain stitches.

- ⑦ Now, decreasing is completed.



In case, the collar is as long as 10 rows or 12 rows.

In the row of "●" mark, change both stitches either side of the front centre needle to plain stitches and transfer these to the front centre needle.

Make three stitches together and multi transfer stitches in the row of this A mark.

In case of 10 rows

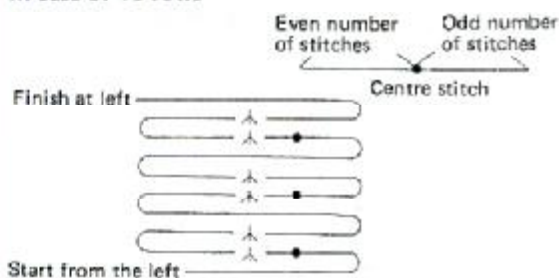

In case of 12 rows

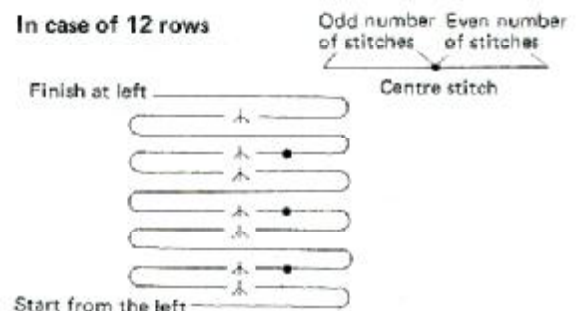

C) Decreasing the stitches on every other row

- ① Pick up the edge stitches of neck line in the same manner as in item A) on page 41.
- ② Knit two rows from the right and change the two purl stitches either side of the front center needle to plain stitches. Then, transfer these two stitches to the front centre needle. (O▲O)



- ④ Knit two rows and transfer both stitches either side of the front centre needle onto the front centre needle. (O▲O) Transfer all the stitches on the left side of the front centre needle to the right. (O///▲||||)

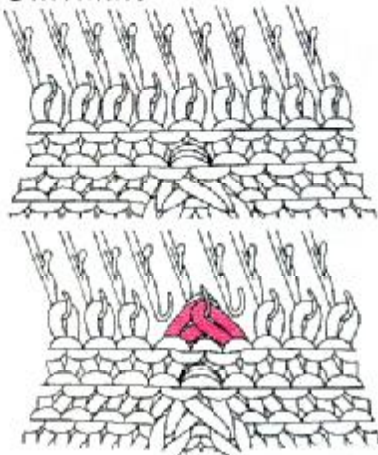

- ⑤ Repeat these steps ②-④ and make three stitches together in the twelfth row and multi-transfer stitches in the thirteenth row, then knit the thirteenth row from the right.

- ③ Transfer all the stitches which are on the left side of the front center needle to the right. (O///▲||||)



- ⑥ Now, decreasing is completed.

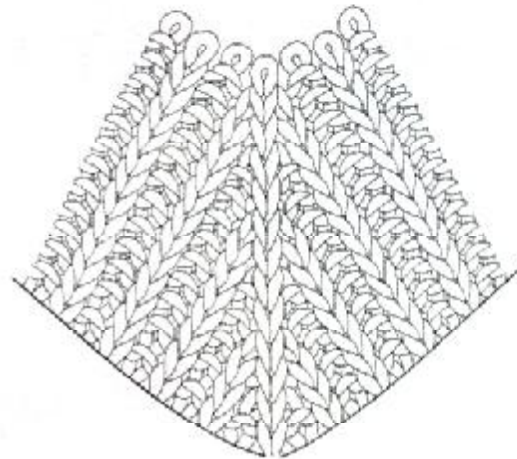

Square neck collar (Using either B or C method)

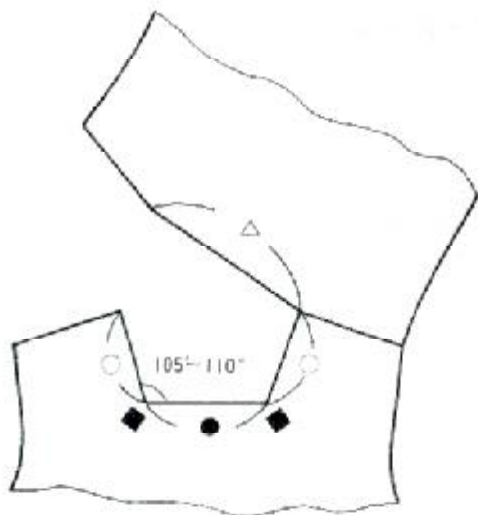

- △ BACK NECK LINE
- FRONT NECK LINE
- FRONT SHAPING
- FRONT CENTRE NECK LINE

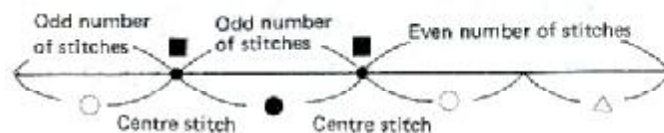

Make complete stitches on the right and left centres of the front neck line, and decrease the stitches in the same manner as the V-neck collar.



9 Partial Knitting

* When doing partial knitting, set the holding cam lever (HCL) to position H. (N.B. Push button machine to II)

Decrease the stitches on every other row

A) Using the front side

① On the opposite side of the K carriage bring forward all the needles which are to be decreased to position E and knit one row. Avoid making a hole by passing the yarn under the stem of first needle in position E as shown in the diagram.

② Knit one row to the other side.

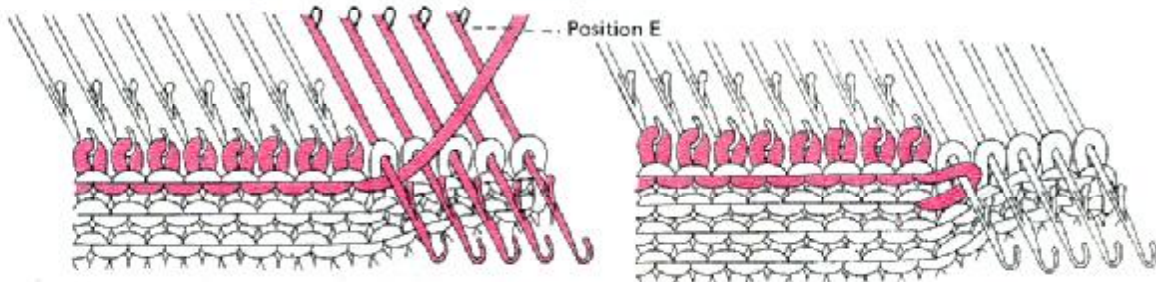

③ On the opposite side of the K carriage bring forward all the needles which are to be decreased to position E and knit one row. Pass the yarn under the stem of first needle in position E. Repeat these steps, the partial knitting is completed.

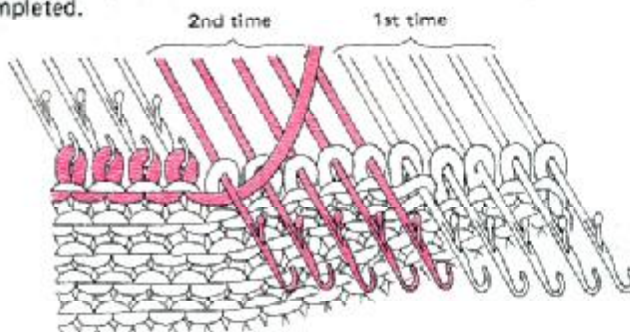

B) Using the wrong side

Decrease the stitches in the same manner as in A).

* Pass the yarn under the stem of first needle in position E behind the stitch as shown in the diagram. Repeat this step, the partial knitting is completed.

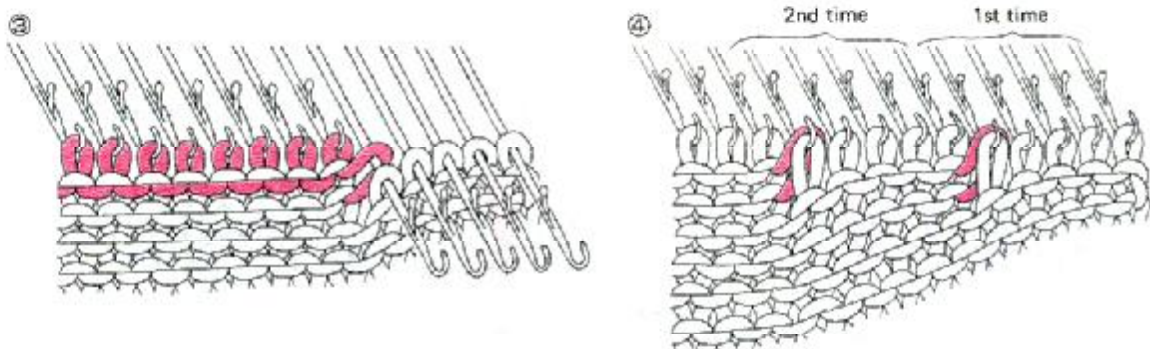
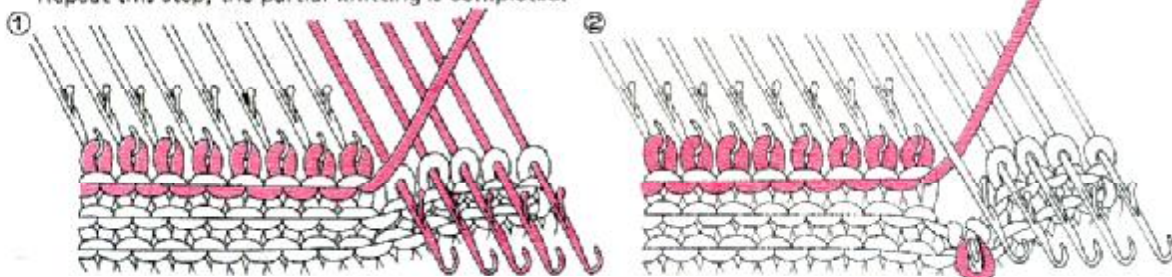

Decrease the stitches on every row

A) Using the front side

① On the opposite side of the K carriage bring forward all the needles which are to be decreased to position E and knit one row.

* Avoid making a hole by passing the yarn under the stem of first needle in position E.

② Bring forward all the needles which are to be decreased to position E. Pass the yarn over and under the needles as shown in the diagram.

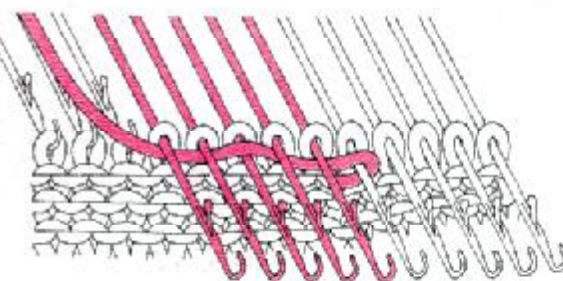
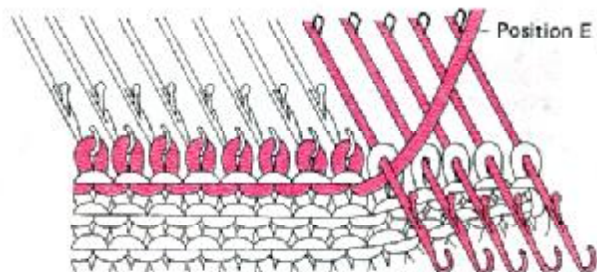

③ Knit one row to the other side. Repeat these steps ①-③ the partial knitting is completed.

2nd time 1st time

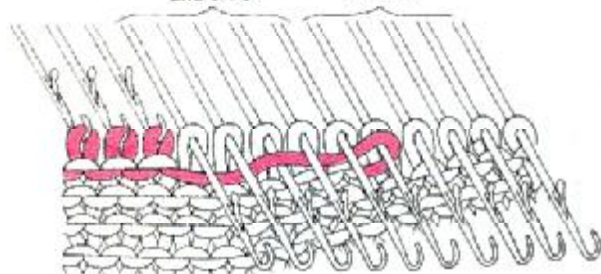

B) Using the wrong side

① Decrease the stitches in the same manner as in item A). Pass the yarn under the stem of first needle in position E behind the stitch as shown in the diagram.

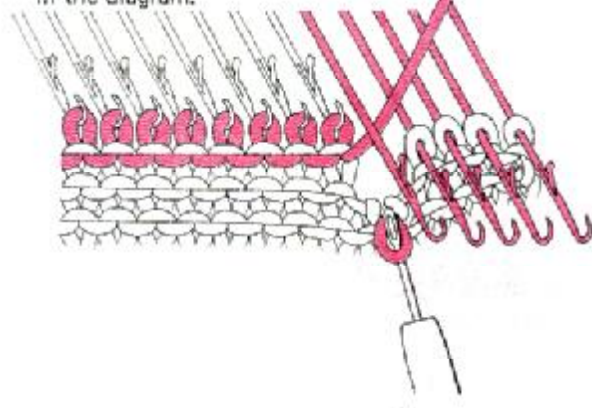

② Transfer all the stitches which are to be decreased to the multi-transfer tool and pass the yarn over and under the needles as shown in the diagram. Then, replace all the stitches which are on the transfer tool to the hook of the needles. Repeat these steps, the partial knitting is completed.

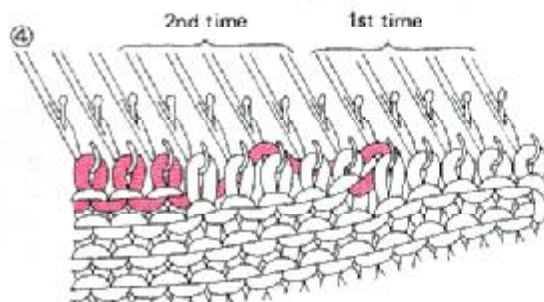
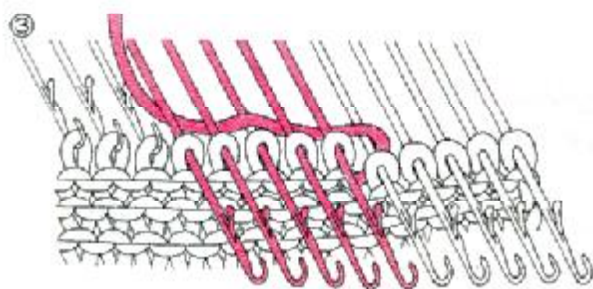
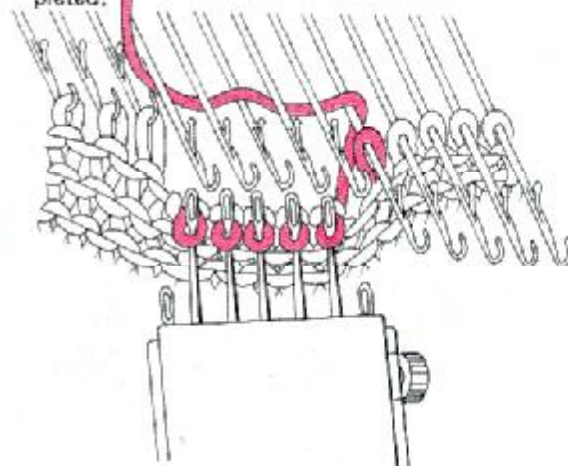

Increase the stitches on every other row

A) Using the front side

① On the opposite side of the K carriage bring forward all the needles for the partial knitting to position E.

② Knit one row and pass the yarn under the stem of first needle in position E. Then, knit one row to the other side.

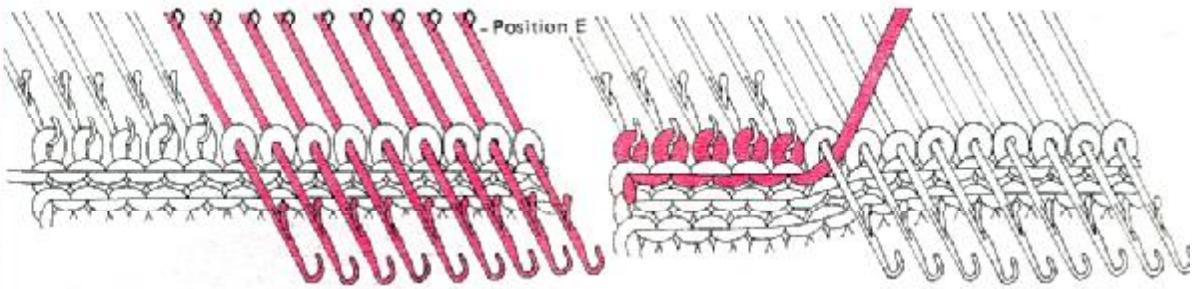
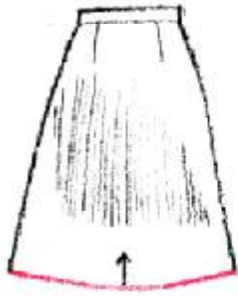

③ On the opposite side of the K carriage push back all the needles which are to be increased to position D.

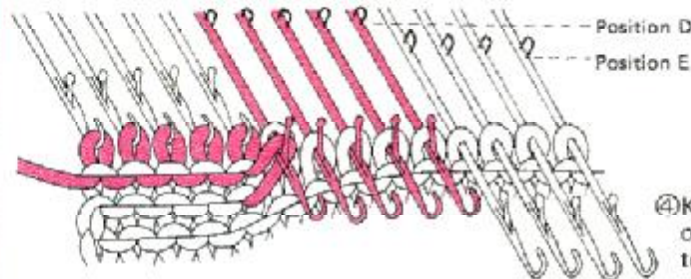

④ Knit one row and pass the yarn under the stem of first needle in position E. Then, knit one row to the other side.

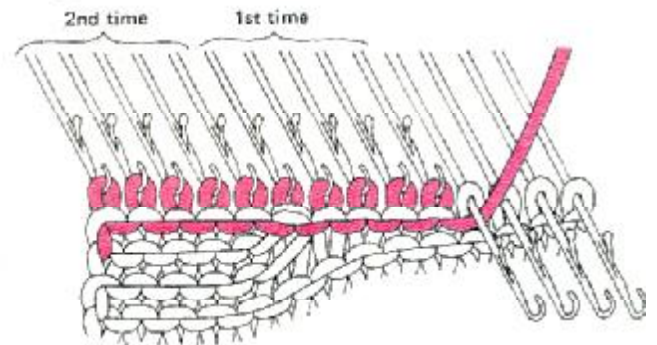

B) Using the wrong side

Increase the stitches in the same manner as in item A). position E behind the stitch as shown in the diagram.

Pass the yarn under the stem of first needle in

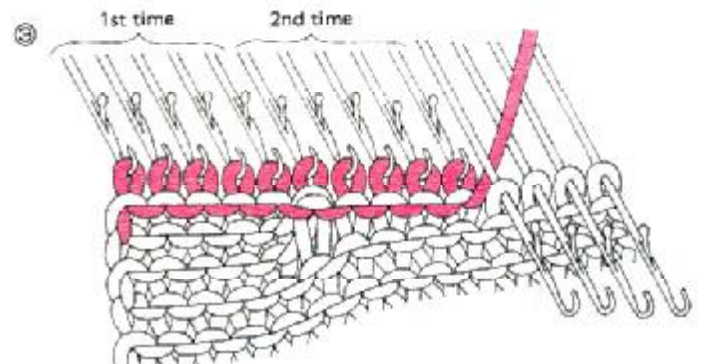
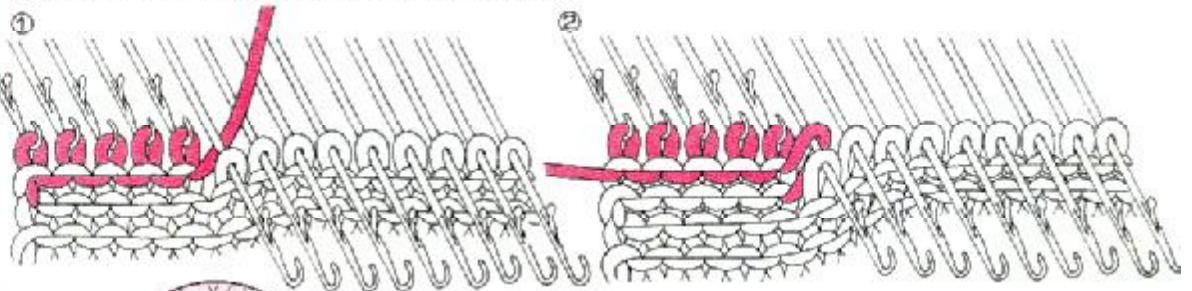

Increase the stitches on every row

A) Using the front side

① On the opposite side of the K carriage bring forward all the stitches for the partial knitting to position E.

② Knit one row and push back all the needles which are to be increased to position D. Pass the yarn over and under the needles as shown in the diagram.

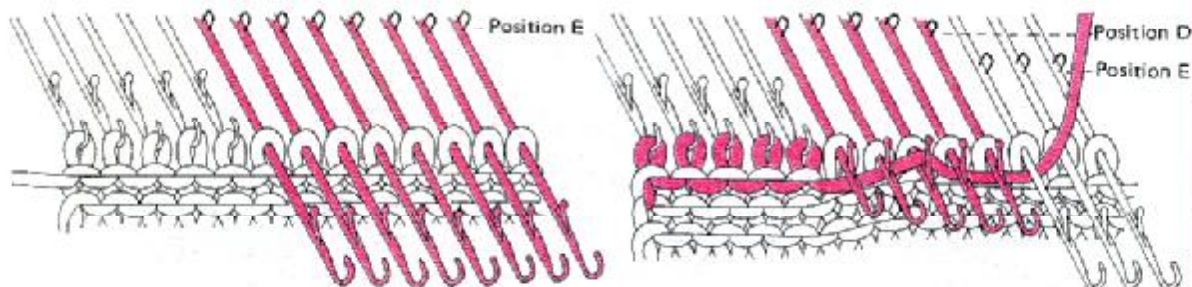

③ Knit one row to the other side.

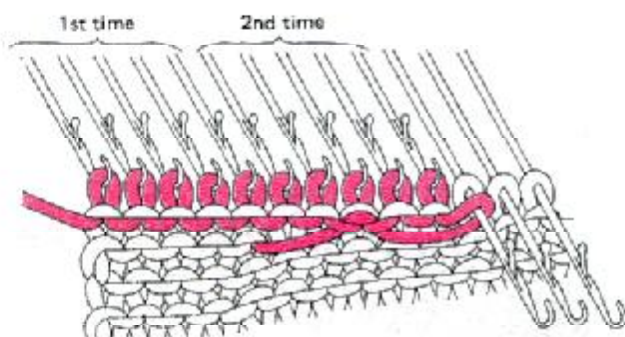

B) Using the wrong side

Increase the stitches in the same manner as in item A). Transfer all the stitches which are to be increased to the multi-transfer tool and pass the yarn over and under the needles as shown in the diagram. Then, transfer all the stitches which are on the transfer tool to the hook of the needles. Repeat these steps, the partial knitting is completed.

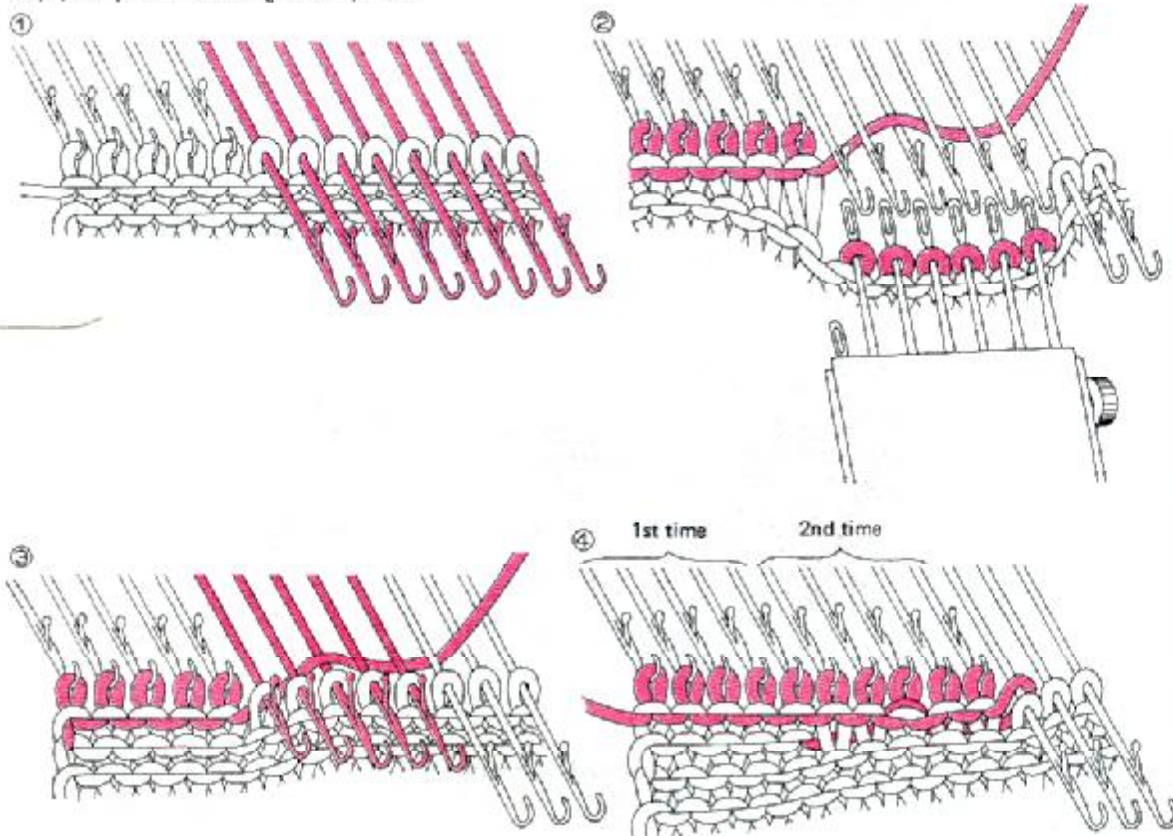

Lace pattern

- ① Knit up to the partial knitting point and place the K carriage on the left side. Set the holding cam lev (HCL) to position H. (N.B. Push bottom machine to II) According to the pattern, bring forward all the needles which are to be decreased to position E. (In this case, bring forward the needles on the right side of the swatch.) Knit one row from the left to right and pass the yarn under the stem of first needle position E. Bring forward all the needles which are to be increased to position E on the left side of the swatch.

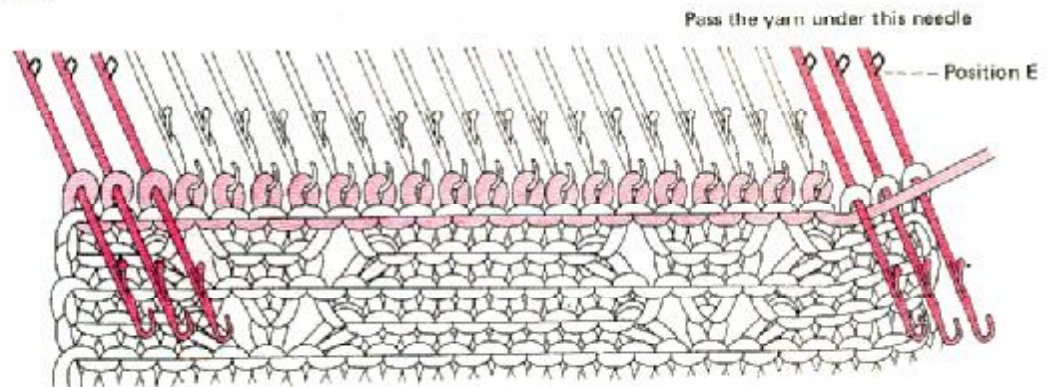

- ② Lay the cast-on thread on the hook of E position needles and bring them back one by one to position manually. Operate the L carriage and make the lace pattern. On the opposite side of the K carriage bring forward the end B position needle to position E.

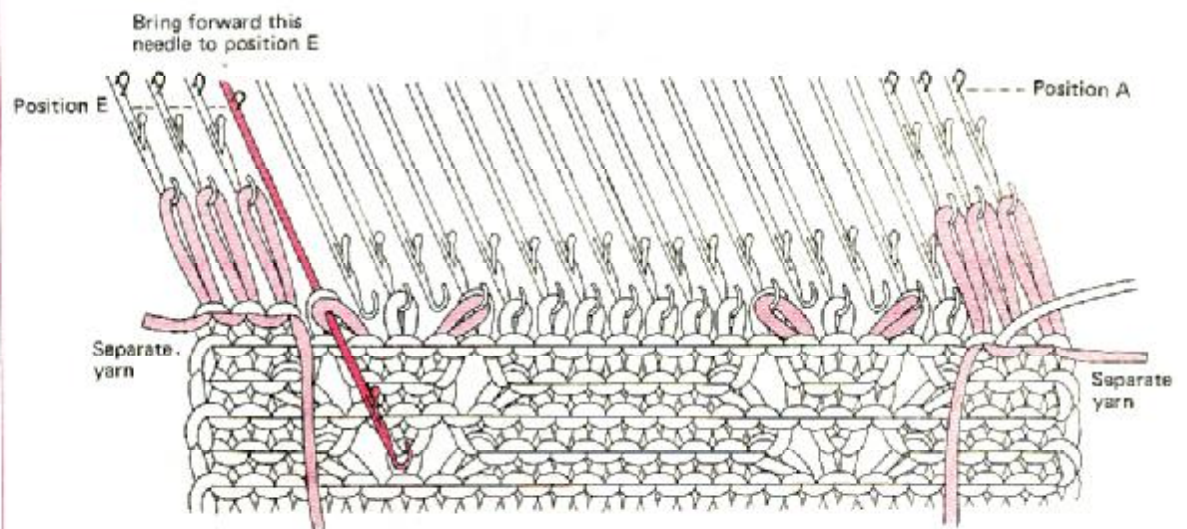

- ③ Knit one row from the right and pass the yarn under the stem of needle in position E. On the right side, bring forward all the needles which are to be decreased to position E.

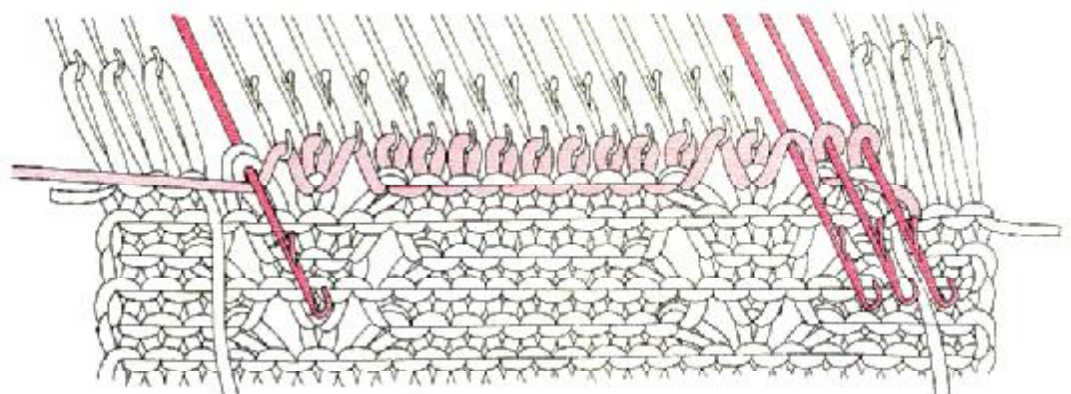

- ④ Repeat these steps ①-③ After finishing the decreasing, transfer all the stitches to the hooks of the need by pulling up the cast-on thread and place all needles in position B. Then, knit the last row of par knitting.

10 Binding off the Stitches

Binding off on the machine

A) Using the tapestry needle

① Pick up all the stitches of the first swatch with its front side facing you and all the stitches of the second swatch with its wrong side facing you. Then, knit several rows with the waste yarn. Using the tapestry needle with the yarn, bind off all the stitches as shown in the diagram.

② At the end of the swatch, pass the tapestry needle through the end stitch as shown in the diagram.

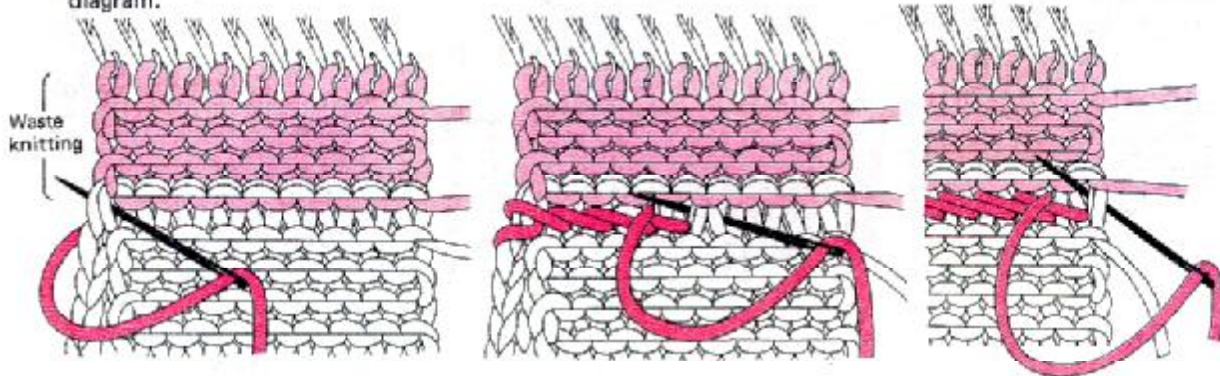

B) Using the latch tool

① Hang the swatches on the machine in the same manner as item A) and knit one row with the tension four numbers higher than main tension. Then, bind off the stitches with the latch tool.

② At the end of the swatch, pass the latch tool through the end stitch as shown in the diagram.

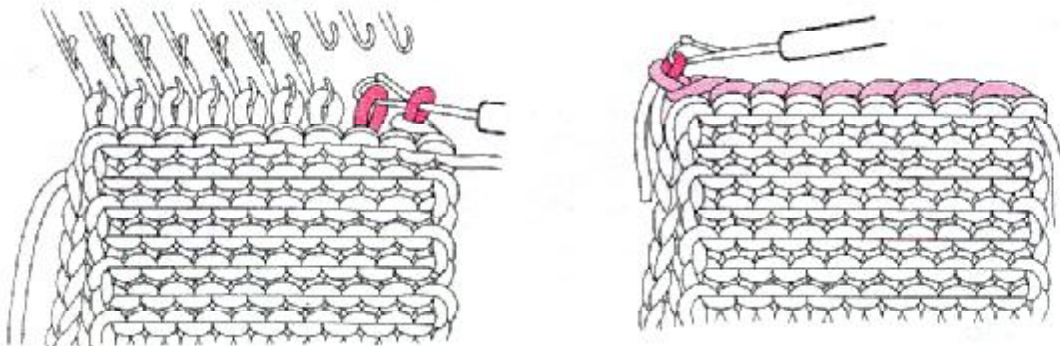

C) Making a single stitch with the latch of the needle and binding off with the tapestry needle

① Hang the swatches in the same manner as in item A) and push back all of the first swatch stitches behind the needle latches. Pass all the stitches over the latches of the needles to make a single stitch as shown in the diagram.

② After knitting with waste knitting, bind off all the stitches with the tapestry needle.

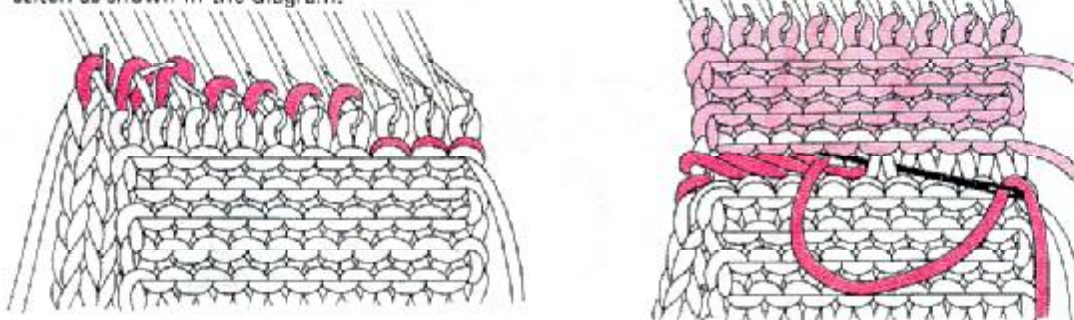

Plain stitch to plain stitch

A) Method (1)

① Insert the tapestry needle with the yarn into the first stitch of both swatches from behind. Insert the tapestry needle into the first stitch from the front and the second stitch from behind on the first swatch, and pass it through the first stitch from the front and the second stitch from behind on the second swatch. Repeat these steps to the end of the knitting.

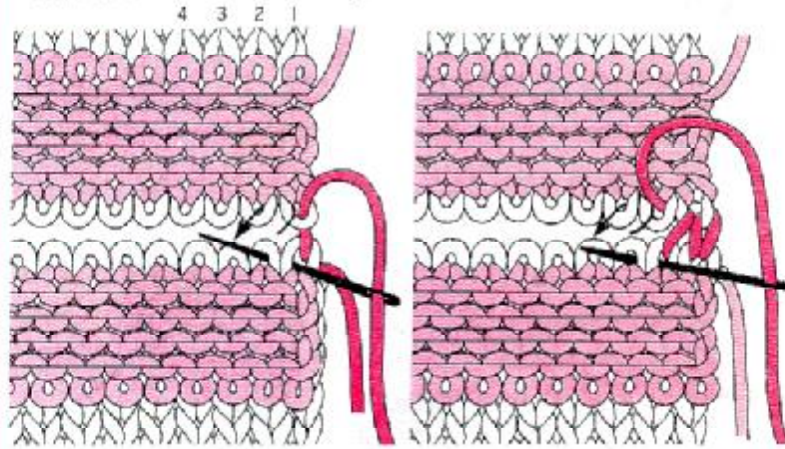

② Insert the tapestry needle into the end stitch of the first swatch and pass it through the end stitch of the second swatch as shown in the diagram. After binding off the stitches, take the waste knitting off the swatches.

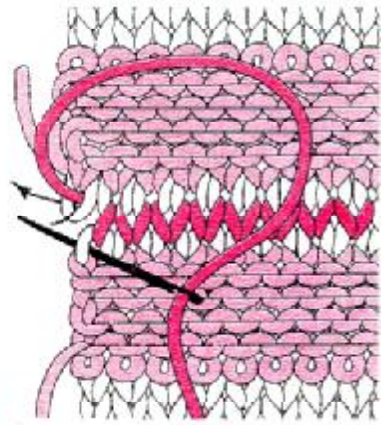

B) Method (2)

① Binding off the stitches in the same manner as in item A). On the finished edge side, pass the tapestry needle through the back of the stitch as shown in the diagram.

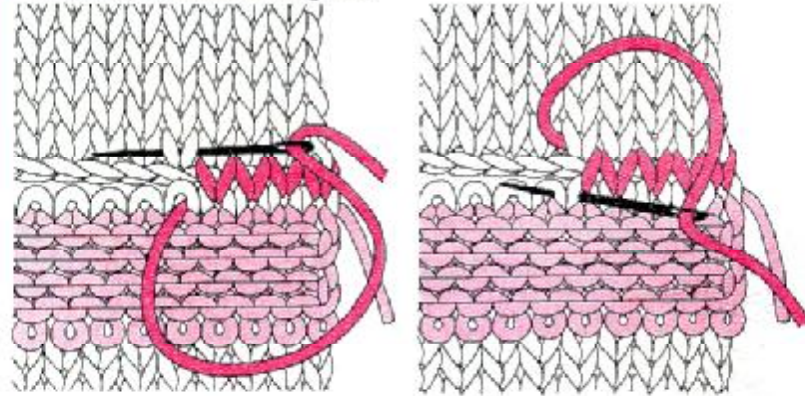

② At the end of the swatch, insert the tapestry needle into the stitches as shown in the diagram. After binding off the stitches, take the waste knitting off the swatches.

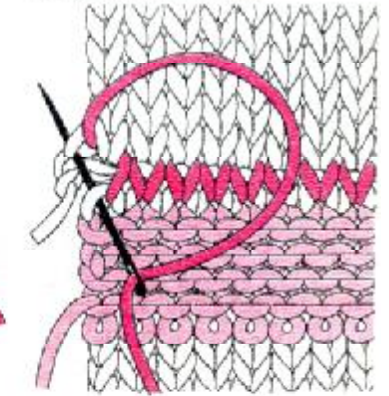

C) Method (3)

① Pass the tapestry needle with the yarn through the end stitch of both swatches from behind. Insert the tapestry needle into the first stitch from the front and pass it through the second stitch from behind on the first swatch.

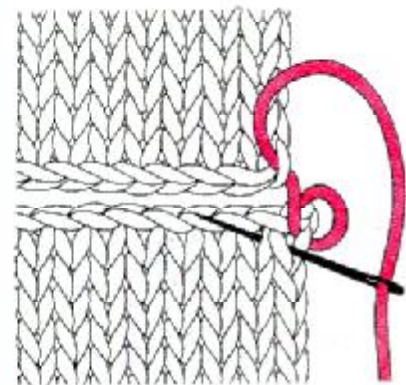

② Pass the tapestry needle through the back of the stitches on the second swatch as shown in the diagram.

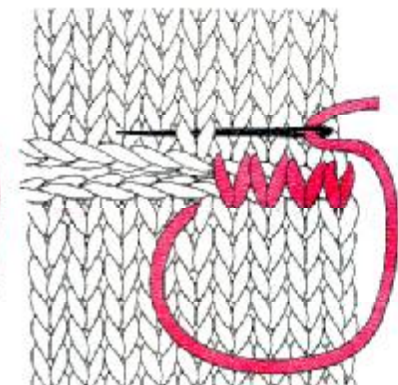

③ At the end of the swatch, insert the tapestry needle into the end stitch as shown in the diagram.

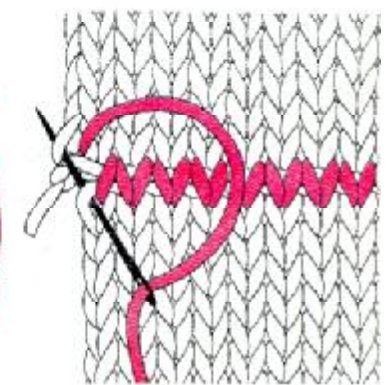

Purl stitch to purl stitch

Fold the waste knitting towards the front side of the swatches. Insert the tapestry needle into the end stitches from the back on both swatches. Insert the tapestry needle into the first stitch from the back and pass it through the second stitch from the front on the first side. Insert the tapestry needle into the first stitch from the back and pass it through the second stitch from the front on the second swatch. Repeat these steps to bind off the stitches.

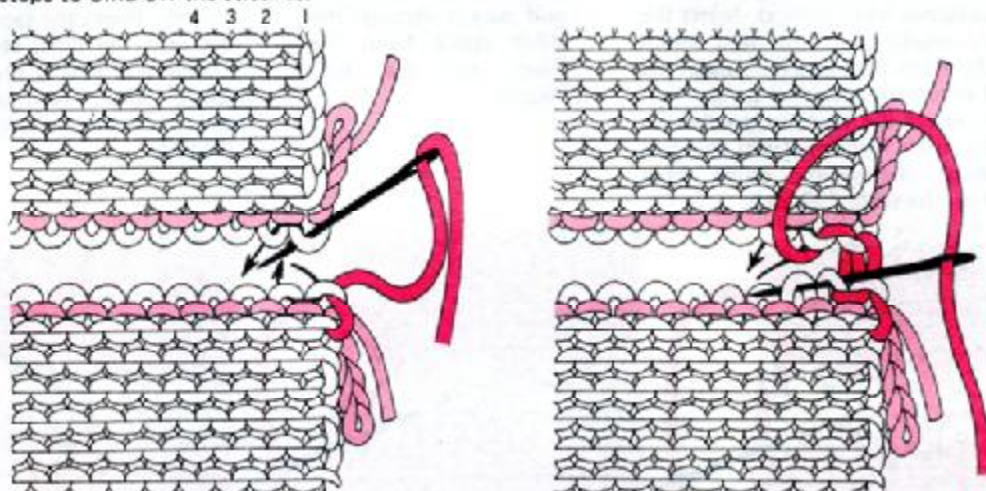

- ② At the end of the swatch, pass the tapestry needle through the end stitch as shown in the diagram. After binding off the stitches, take the waste knitting off the swatches.

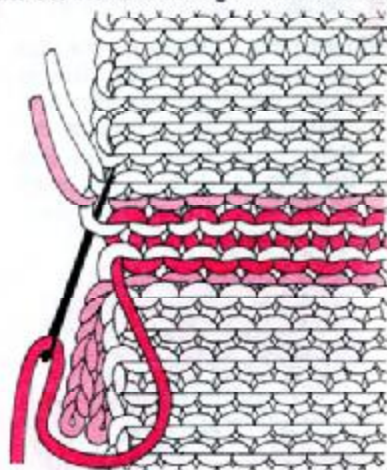

Garter stitches

- ① Knit last row of the first swatch with the purl stitches and last row of the second swatch with the plain stitches. (Place the first swatch on this side and the second swatch on the other side.) Fold the waste knitting toward the front side of the swatches. Insert the tapestry needle into the end stitch of both swatches. Insert the tapestry needle into the first stitch from the front and pass it through the second stitch from behind on the first swatch. Insert the tapestry needle into the first stitch from behind and pass it through the second stitch from the front on the second swatch. Repeat these steps.

- ② At the end of the swatch insert the tapestry needle into the end stitch as shown in the diagram. After binding off the stitches, take the waste knitting off the swatches.

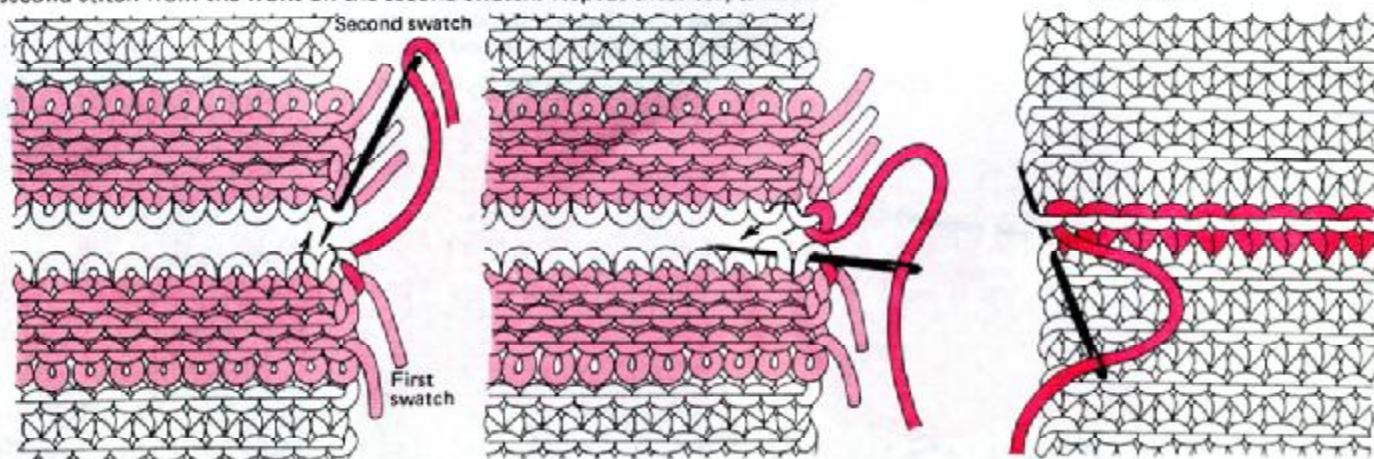

Rib knitting

A) Method (1)

① Fold the waste knitting towards the front side of the swatches. Insert the tapestry needle into the end stitch of both swatches from behind. Insert the tapestry needle into the first stitch from the front and pass it through the second stitch from behind on the first swatch. Insert the tapestry needle into the first stitch from the front and pass it through the second stitch from behind on the second swatch.

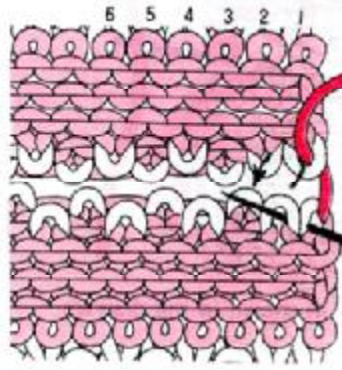

② Insert the tapestry needle into the second stitch from the front and pass it through the third stitch from the front on the first swatch.

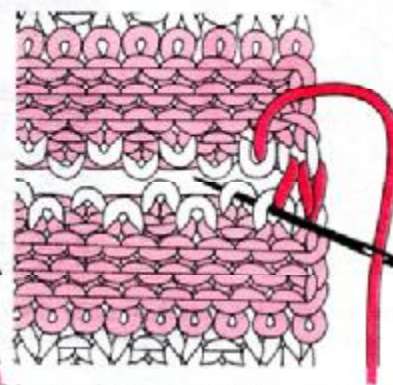

③ Pass the tapestry needle through the third stitch from the front on the second swatch. Insert the tapestry needle into the third stitch from behind and pass it through the fourth stitch from behind on the first swatch as shown in the diagram.

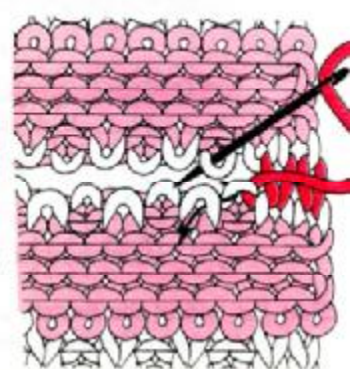

④ Insert the tapestry needle into the second stitch from the front and pass it through the fourth stitch from behind on the second swatch.

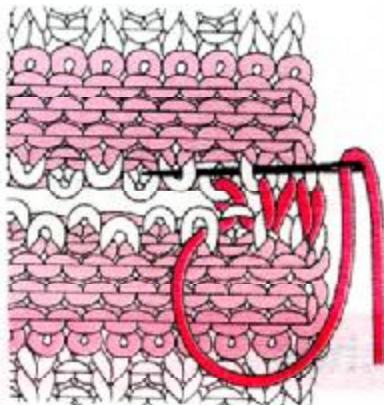

⑤ Insert the tapestry needle into the fourth and fifth stitches from the front on the first swatch, and pass it through the third stitch from behind and the fifth stitch from the front on the second swatch as shown in the diagram.

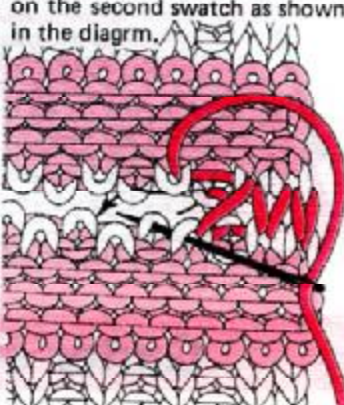

⑥ Insert the tapestry needle into the fifth stitch and the sixth stitch from behind on the first swatch.



⑦ Repeat these steps ④-⑥.

⑧ At the end of the swatch, insert the tapestry needle into the second stitch from the front and pass it through the first stitch from behind on the first swatch. Insert the tapestry needle into the second stitch from the front and pass it through the first stitch from behind on the second swatch. Insert the tapestry needle into the first stitch from the front on the first swatch and pass it through the third and first stitches from behind on the second swatch.

⑨ After binding off the stitches, take the waste knitting off the swatches.

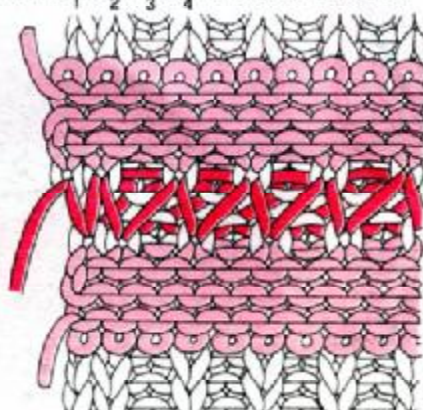
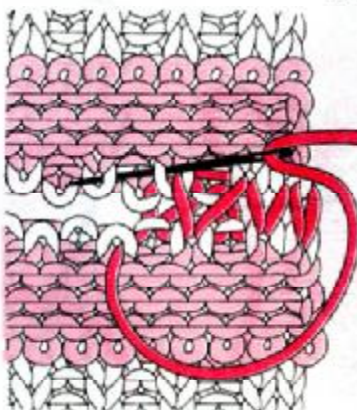

Look at sample from the right side

B) Method (2)

① Fold the waste knitting towards the front side of the swatches. Insert the tapestry needle into the first stitch from behind on the first swatch, pass it through the first stitch from the front and the second stitch from behind on the second swatch. Insert the tapestry needle into the first stitch from the front and the second stitch from behind on the first swatch, pass it through the second stitch from the front and the third stitch from behind on the second swatch as shown in the diagram.

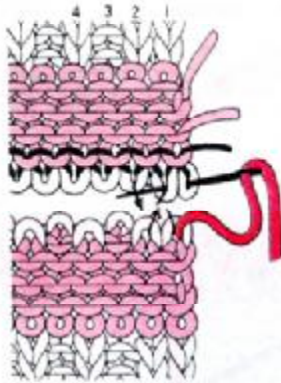

② Insert the tapestry needle into the second stitch from the front and pass it through the third stitch from the front on the first swatch. Insert the tapestry needle into the third stitch from behind and pass it through the fourth stitch from the front on the second swatch. Insert the tapestry needle into the third stitch from behind and pass it through the fourth stitch from behind on the first swatch.

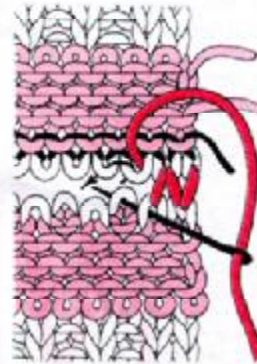

③ Repeat these steps and at the end of the swatch, pass the tapestry needle through the end stitch as shown in the diagram. After binding off the stitches, take the waste knitting off the swatches.



Edge stitch to the plain stitch

A) Method (1)

Insert the tapestry needle into the plain stitch (in the same manner as in item plain stitch to plain stitch on page 50) on the plain stitch side and pass it under the threads of the first and second rows on the edge stitch side as shown in the diagram.

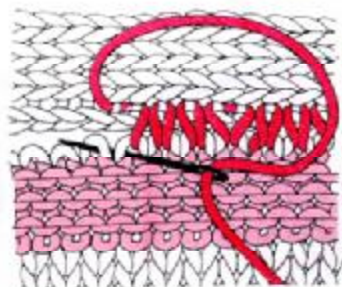
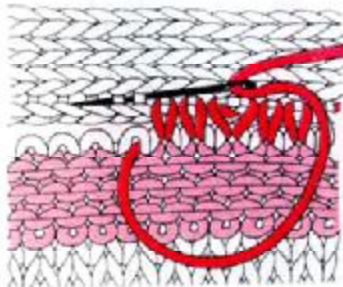

B) Method (2)

Insert the tapestry needle into the plain stitch on the plain stitch side and pass it under the needle loop of first row on the edge stitch side.

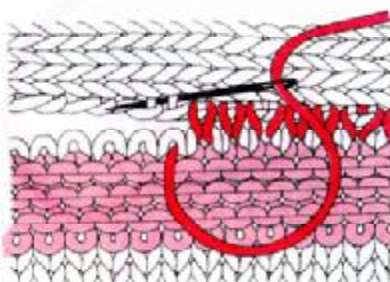

Small number stitches to the larger number stitches

At first, hold the front side of the swatch with the smallest number of stitches facing you and hook them onto the machine. Then, hold the wrong side of the swatch with the largest number of stitches facing you and hook them onto the machine. (This time, overlapping the stitches at certain intervals as shown in the diagram.)

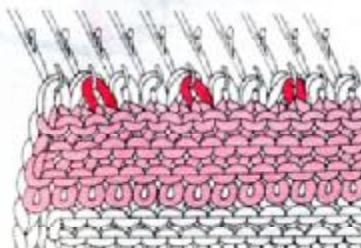

Decreasing (increasing) evenly

1) How to calculate the decreasing (increasing) stitches.

ex. 104 stitches (Pattern A) - 84 stitches (Pattern B) = 20 stitches (the number of stitches for decreasing (increasing)) + 1 (extra stitch for seaming) = 21

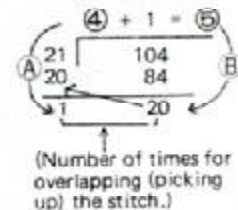

A ... Overlap the 4th stitch onto the 3rd stitch one time.

B ... Overlap the 5th stitch onto the 4th stitch 20 times.



(※ When increasing the stitch, make a new stitch by picking up the sinker loop.)

11 Seaming

Blind stitches (1)

A) Plain stitches

① Insert the tapestry needle into the edge stitch of both swatches as shown in the diagram. Pass the tapestry needle under the threads of first and second row. Every few stitches draw up the yarn.

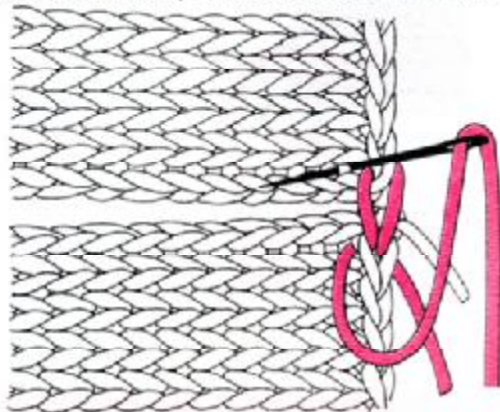

② Repeat this until to the end of swatches, pass the tapestry needle through the end stitches as shown in the diagram.

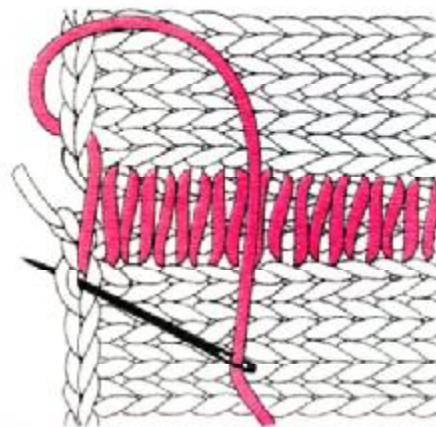

B) Purl stitches

① Insert the tapestry needle into the end stitch of both swatches as shown in the diagram. Pass the tapestry needle under the sinker loop of the second stitch. Every few stitches draw up the yarn.

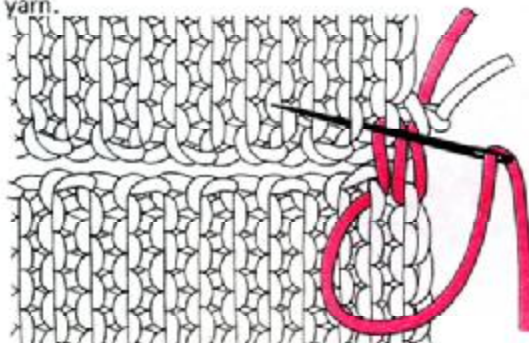

② Repeat this until to the end of the swatches pass the tapestry needle through the end stitches as shown in the diagram.

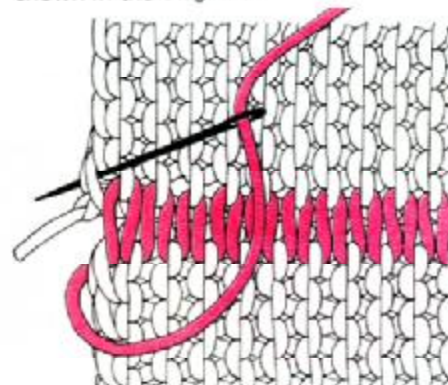

C) 1 x 1 rib

① Hold the front side of swatch facing you, insert the tapestry needle into the first and second stitch on the first swatch as shown in the diagram.

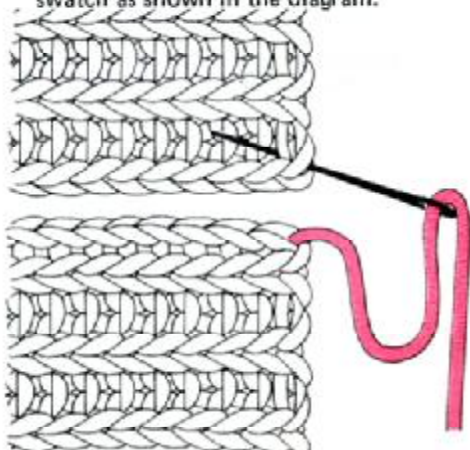

② Insert the tapestry needle into the end stitch on the second swatch as shown in the diagram.

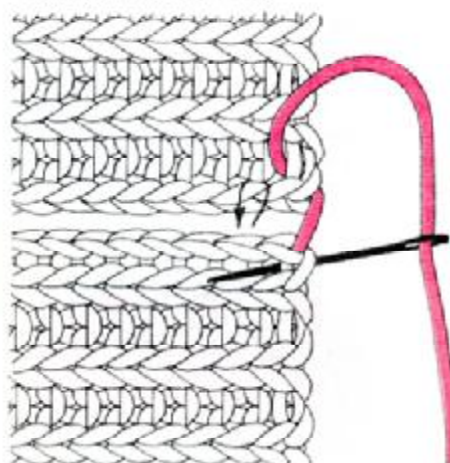

③ Pass the tapestry needle under the sinker loop of the second stitch on the first side and pass it under the threads of the first and second rows of the second swatch as shown in the diagram.

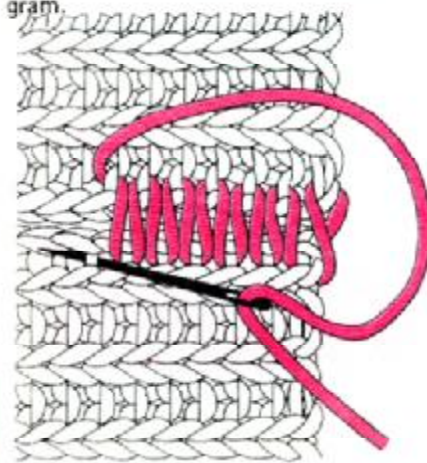

Blind stitches (2)

A) Plain stitches

- ① From the front side of the swatch, pick up half of the edge stitch with the tapestry needle as shown in the diagram.

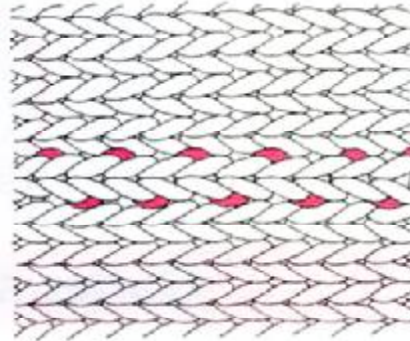
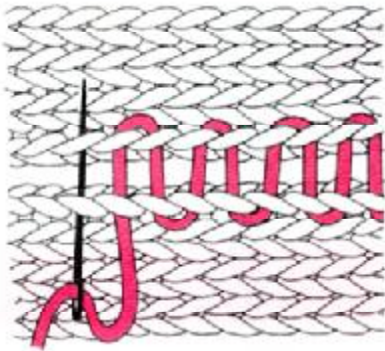

B) 1 x 1 rib

- ① From the front side of the swatch, insert the tapestry needle into the edge stitch of both swatches as shown in the diagram.

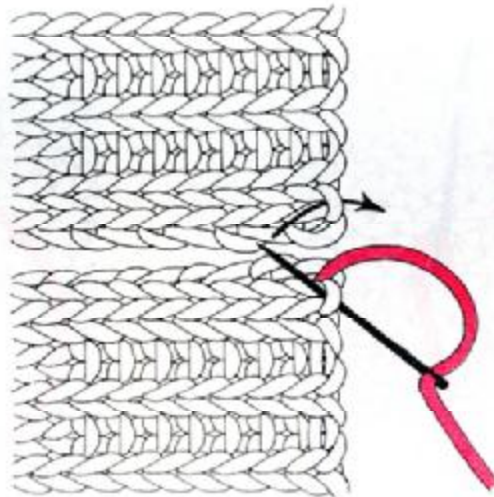

- ② Turn over both swatches. Pick up half of the edge stitch as shown in the diagram.

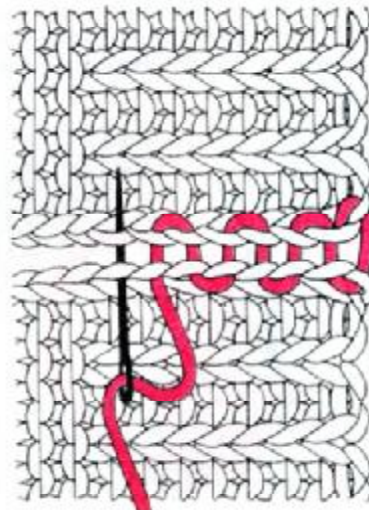
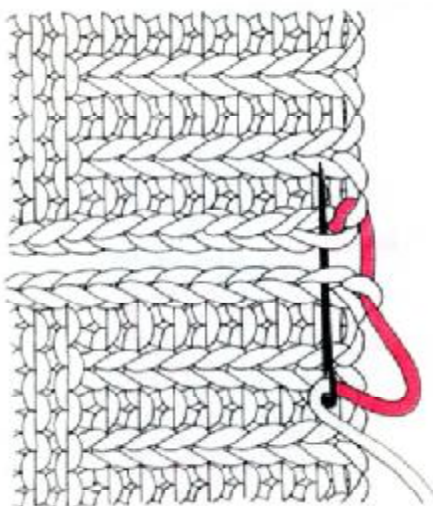

Blind stitches (3)

From the wrong side of the swatch, pick up the edge loop with the tapestry needle as shown in the diagram.

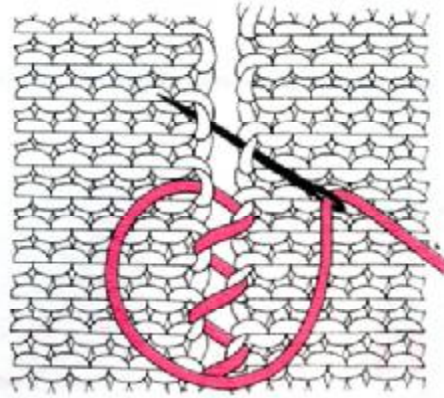

Garter stitches

N.B.

Taking the stitch scale it is possible to find the ratio of stitches, by looking at both sides of the scale, i.e. on the small side of the rule 5 stitches to every 7 stitch on the large side of the rule. Therefore when picking up threads on the small side you would pick up every thread, on the large side you would pick up one thread then two threads then one thread again and repeat this procedure to the edge of the swatch.

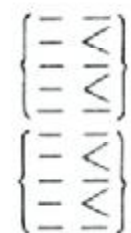

A) On the second stitch

From the front side of swatch, seam the purl stitches with the tapestry needle. Pick up the first sinker loop on the first swatch and second needle loop on the second swatch as shown in the figure.

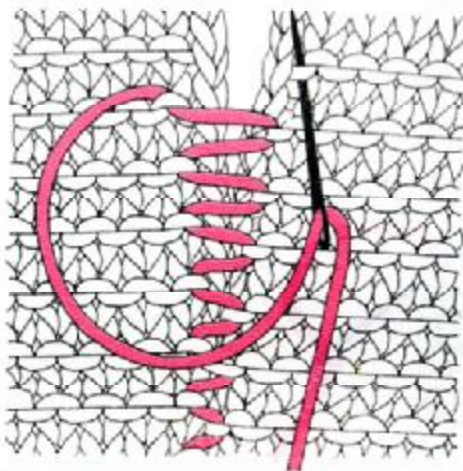

B) On the first stitch

From the front side of the swatch, pick up the purl stitches on both swatches with the tapestry needle.

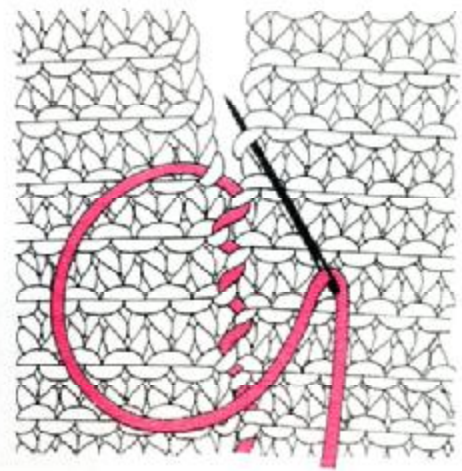

Small number stitches to the larger number stitches

A) Blind stitch (1)

Calculate the ratio of the stitches, pick up the two threads on the swatch with the largest number of stitches at certain intervals as shown in the diagram. (See. N.B.)

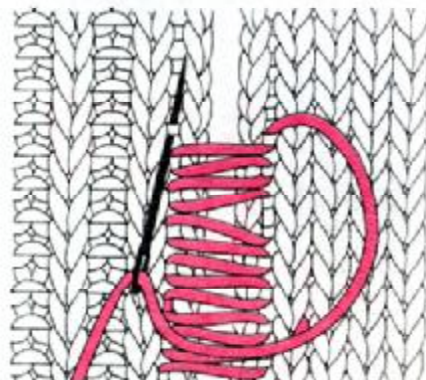

B) Blind stitch (2)

In the same manner as in item A).

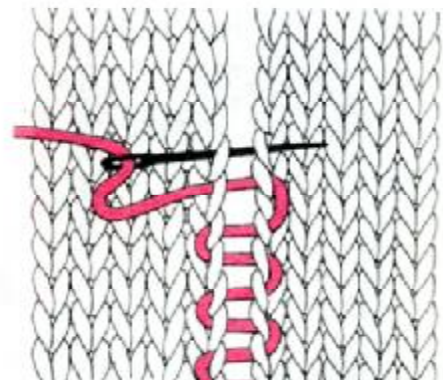

A) Plain knitting

① Fold part of the knitting to the wrong side and insert the tapestry needle into the end stitch.

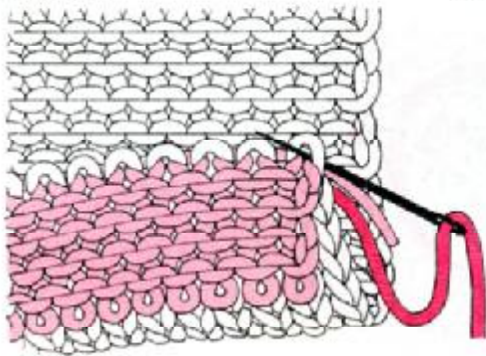

② Insert the tapestry needle into the first stitch from behind and pass it through the second stitch from the front on the wrong side of the swatch. Insert the tapestry needle into the first stitch from the front and pass it through the second stitch from behind on the edge of the folded part as shown in the diagram.

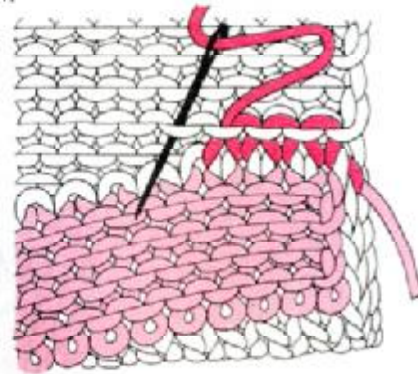

③ At the end of swatch, pass the tapestry needle through the end stitch as shown in the diagram.

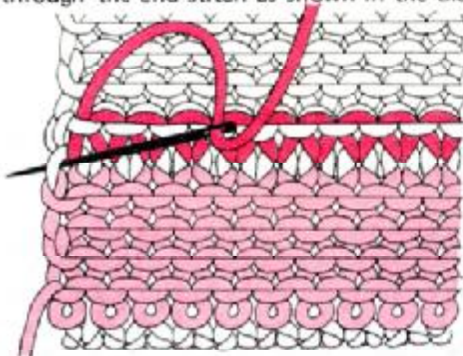

④ After grafting, take the waste knitting off the swatches.

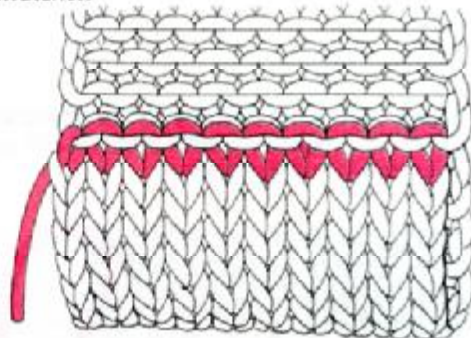

B) 1 x 1 rib

① Fold part of the knitting to the wrong side and insert the tapestry needle into the end stitch.

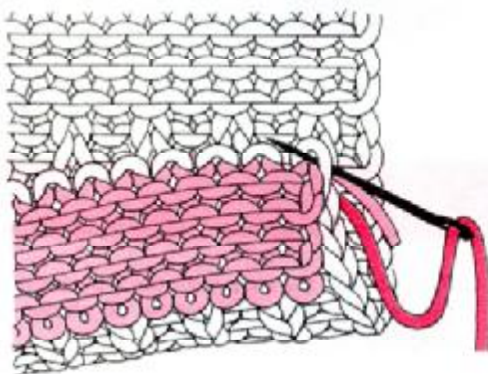

② Insert the tapestry needle into the first stitch from the front and pass it through the second stitch from behind on the wrong side of the swatch. Insert the tapestry needle into the first stitch from the front and pass it through the second stitch from behind on the edge of the folded part as shown in the diagram.

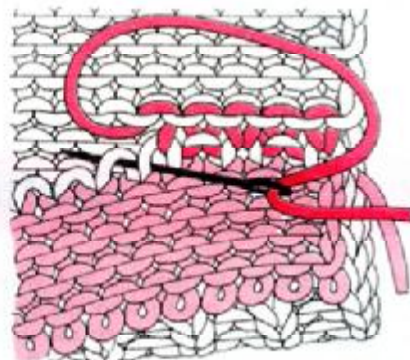

③ At the end of swatch, pass the tapestry needle through the end stitch and take the waste knitting off the swatch.

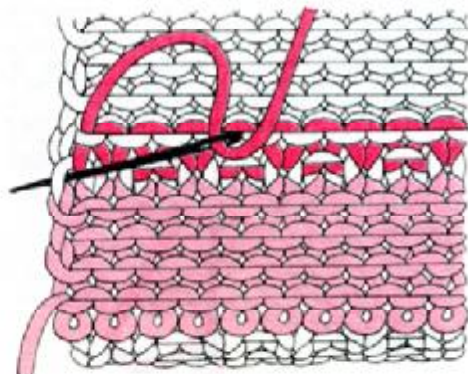

A) Plain knitting



Bind off the last stitches with the latch tool. Fold part of the knitting to the wrong side and pick up half of the edge stitch and half of the sinker loop to graft the edge of the swatch. As shown in the diagram.

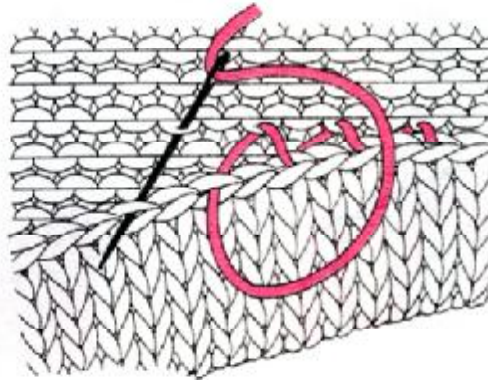

B) 1 x 1 rib

① Fold part of 1x1 rib knitting to the wrong side and insert the tapestry needle into the end purl stitch as shown in the diagram.

② Pass the tapestry needle through the first sinker loop on the knitting and the plain stitch on the edge to graft the edge of the swatch.

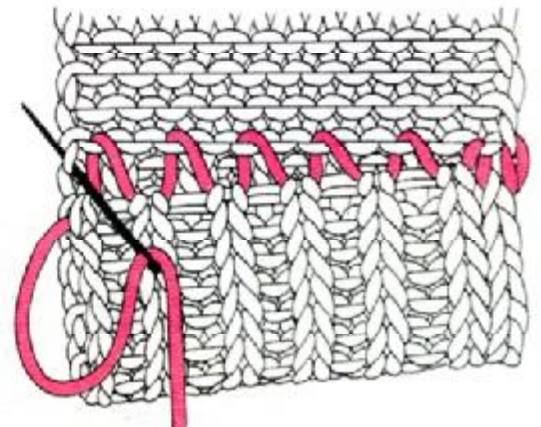
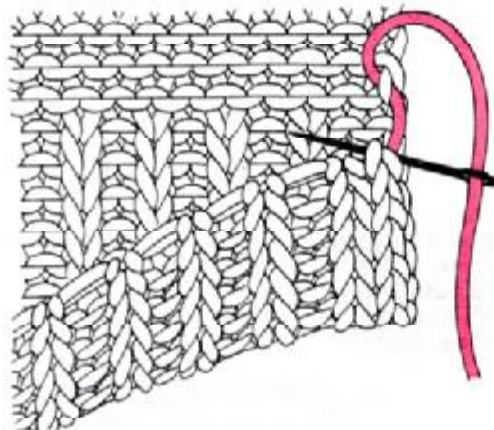

Grafting (3)

① Fold the edge of knitting to the wrong side. Insert the tapestry needle into the sinker loop from behind and pass it through the sinker loop from the front as shown in the diagram.

② Pick up half the loop with the tapestry needle on the wrong side of swatch as shown in the diagram.

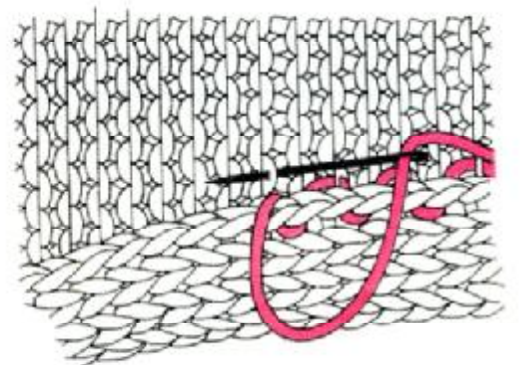
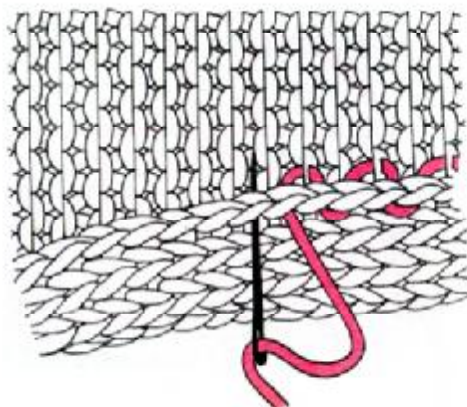

A) Row to row

① Put the swatches together inside out. Pass the tapestry needle through the first and the second loop as shown in the diagram.

② Pass the tapestry needle through the second and the third sinker loops. Repeat these steps.

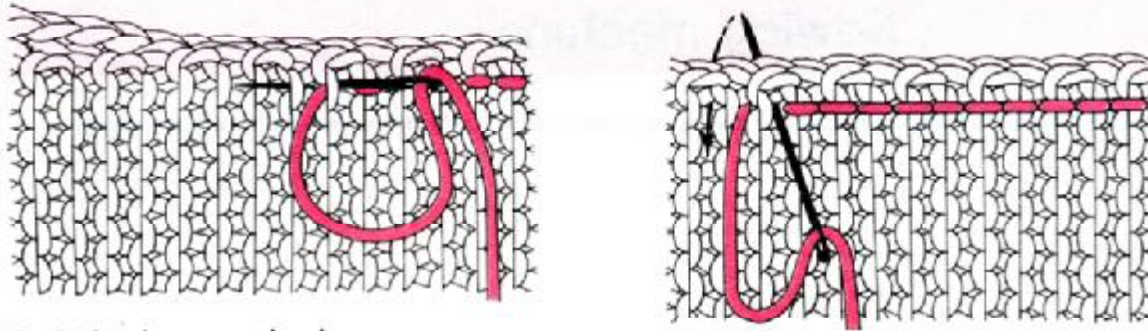

B) Stitch to stitch

① Put the swatches together inside out. Pass the tapestry needle through the first and the second stitches and pass it through the second and the third stitches as shown in the diagram.

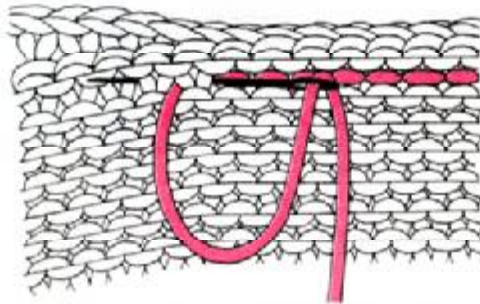

With crochet hook

A) Row to row

Put the swatches together inside out. Insert the crochet hook into the sinker loop and catch the yarn, then pull it back to crochet the swatches. As shown in the diagram.

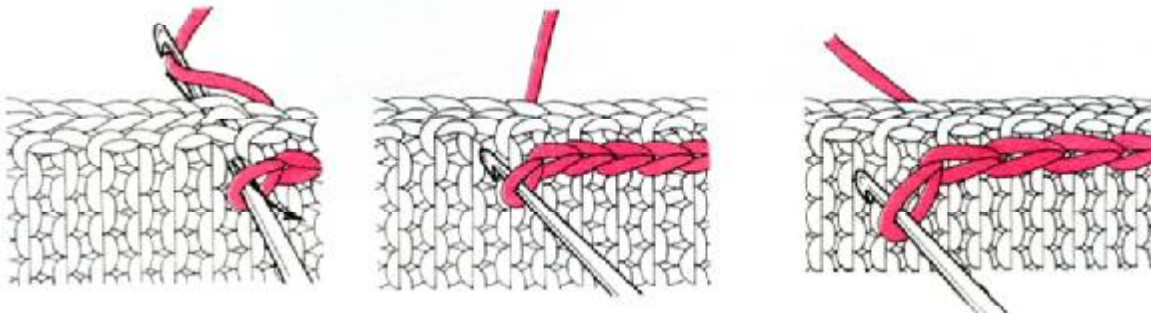

B) Stitch to stitch

Put the swatches together inside out. Crochet the swatches in the same manner as the over stitching.

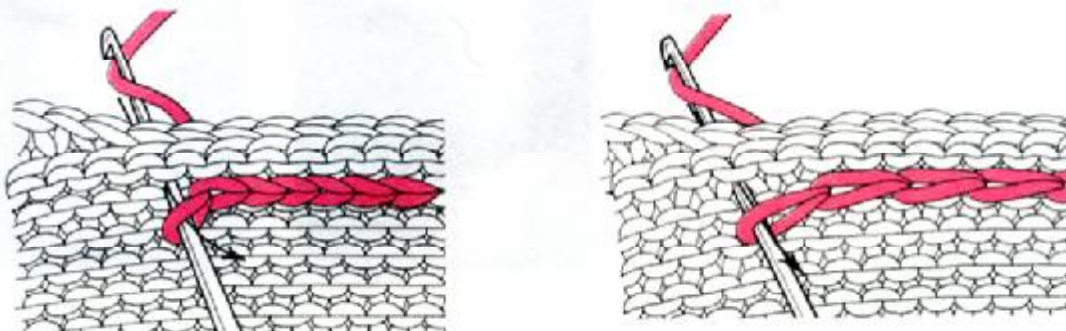

Sewing machine

You can use the straight stitch and/or the zigzag stitch sewing machine for seaming the knitted swatches.

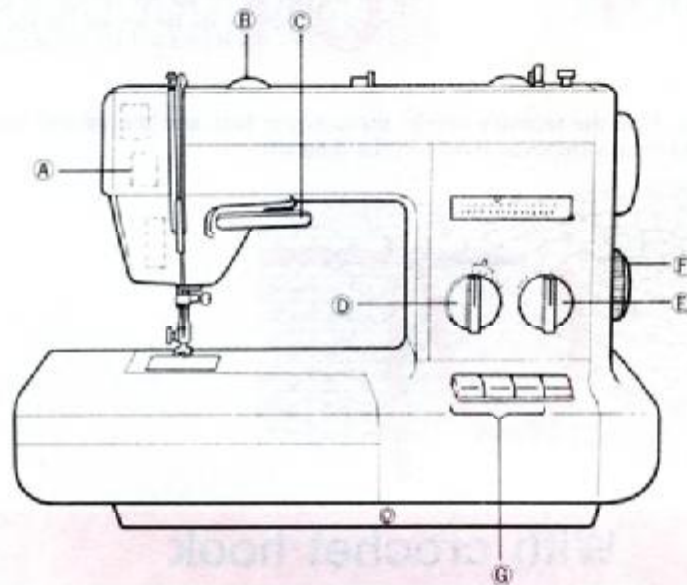

NAME OF PARTS.

- A. Presser control lever.
- B. Upper tension control dial.
- C. Reverse sewing lever.
- D. Zigzag width manual dial.
- E. Stitch length manual dial.
- F. Pattern selection dial.
- G. Speed control buttons.

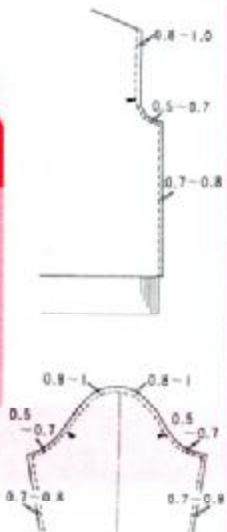

A) Sewing needle

No. 14 sewing needle is very suitable for the knitted swatch. (If the swatches are made of finer yarns it would be better to use No. 11 sewing needle.)



B) Sewing thread

Nylon thread is suitable for the knitted swatch.

Sewing thread



Nylon thread



Bind the swatches with the binding wire and/or the basting thread.



Practise the sewing up

- 1 Prepare the 20 cm x 20 cm wide knitted swatch for practicing.
- 2 **Adjustment**
Before sewing, adjust the sewing machine according to the thickness of the knitted swatches.

Type of knitted swatch	Sewing thread	Sewing needle	Upper tension dial	Presser control lever	Stitch length dial	Zigzag width dial
Thin	Nylon thread	11	Decrease	2	2 – 3	1 – 3
Normal	"	11 – 14	Normal	2	2 – 3	1 – 5
Heavy	"	14	Increase	2	2 – 4	1 – 5

presser foot

Stretch stitch/straight stitch presser foot are suitable for the knitted swatches.

Stretch stitch Presser foot.



Zigzag stitch presser foot.



Straight stitch presser foot.



④ **Stitch length.**
Stitch length manual dial.



④ **Zigzag width.**
Zigzag width manual dial.



⑤ **Upper thread/lower thread.**
Threading in order as shown in the diagram.

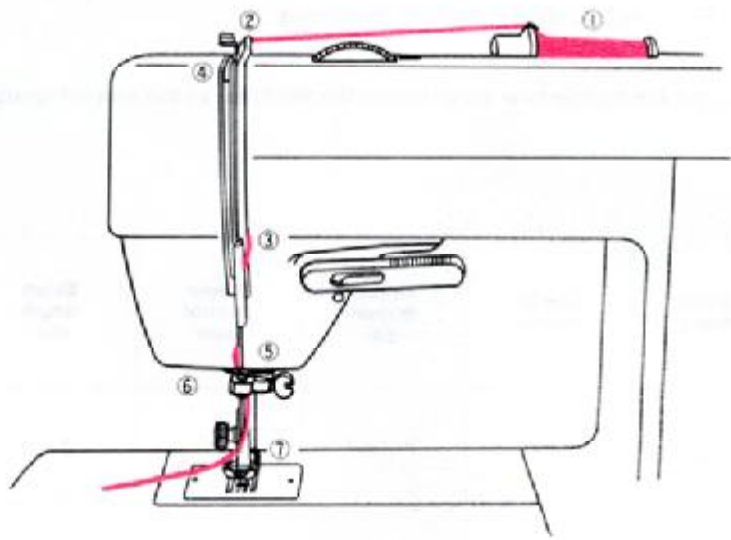

⑥ **Tension.**
Adjust the tension according to the knitted swatch. Puckering and thread breakage might occur if set incorrectly.

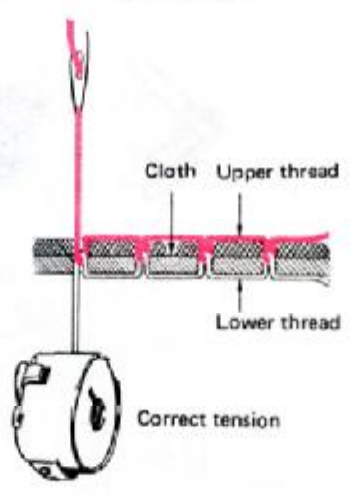

A) Suitable stitch for the knitted swatch

① Straight stitch

(Straight stitch does not stretch.)

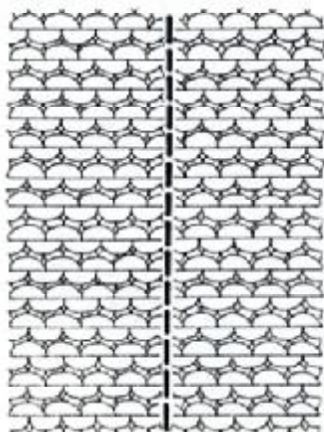

② Zigzag stitch

(Zigzag stitch is very stretchy.)

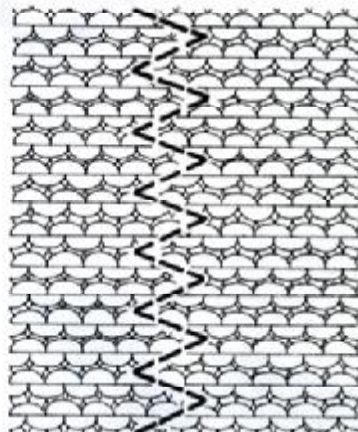

B) Practise the basic sewing

① Stretch stitch

Place the knitted swatches on the machine.
Just guide the knitted swatches slightly as machine feeds them automatically.

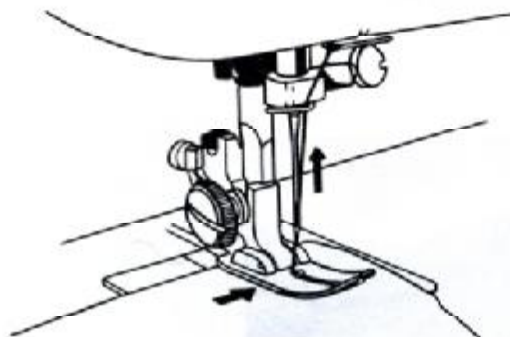

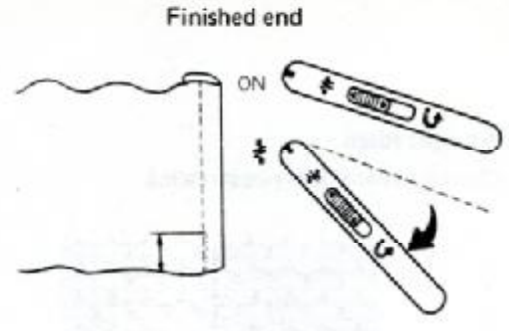
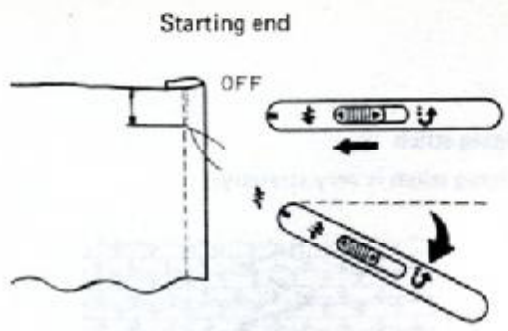

③ Straight corner sewing.

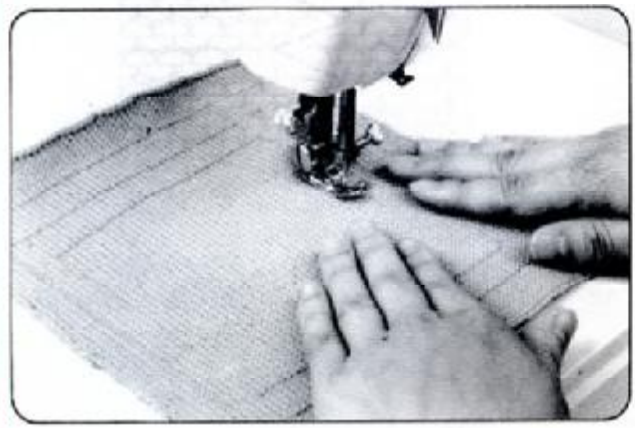

④ Circular sewing.



Sewing up the knitted swatches

A) Sides of bodies, sleeves, shoulders and skirt

(BODY)

① Put the swatches together inside out and pin the parts to be basted.

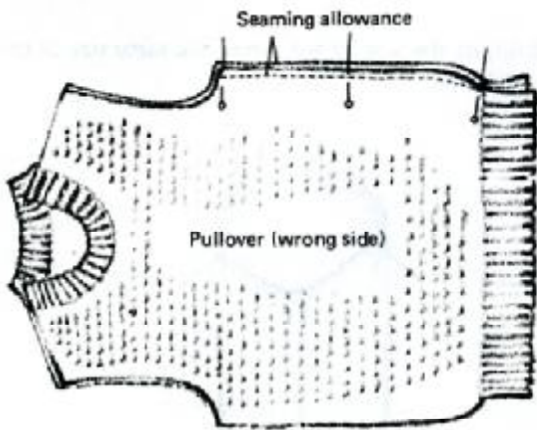

② Baste the sides with the binding wire as shown in the diagram.

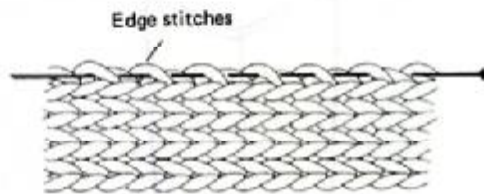
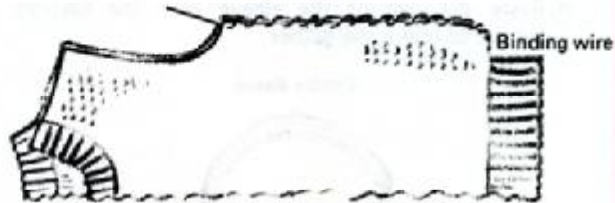

③ Iron the swatches lightly with a steam iron.

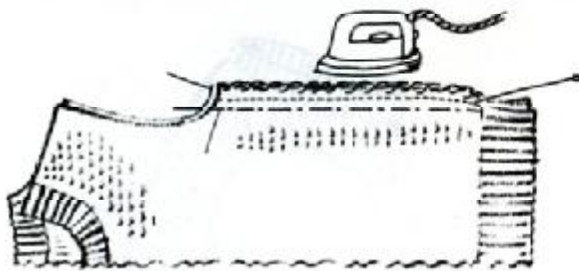

④ Sew the sides of the bodies.



⑤ Sew the shoulders, sleeves and skirt in the same manner as the bodies.

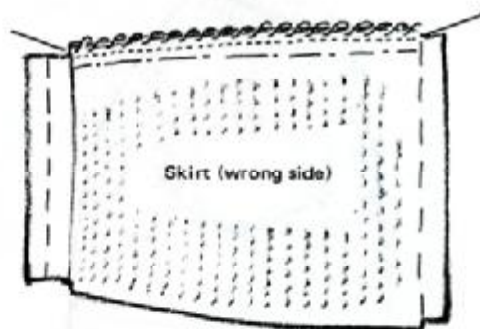
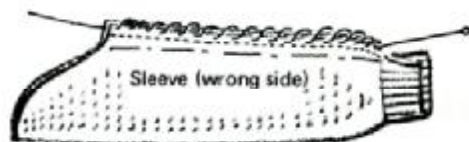
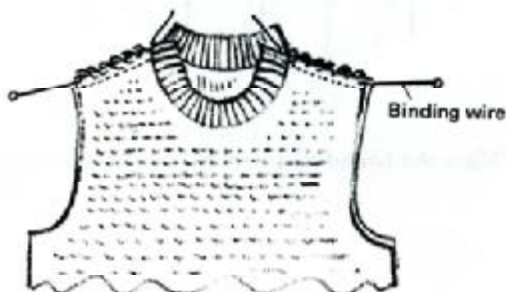

✳ How to sew

- ① Draw the upper and lower threads by 15 cm (6 inches) to the back of the machine and place the swatches on the machine.
- ② Sew the ends of swatches with reverse stitch. Guide the swatches slightly as machine feeds them automatically.
Slow down the speed at the end of the swatches and stop the machine. Sew the end of the swatches with reverse stitch.

B) Attach sleeves to armhole

- ① Baste the top of the sleeve with the basting thread to make the gather.
- ② Adjust the size of the sleeve the same size of the armhole.

Centre sleeve

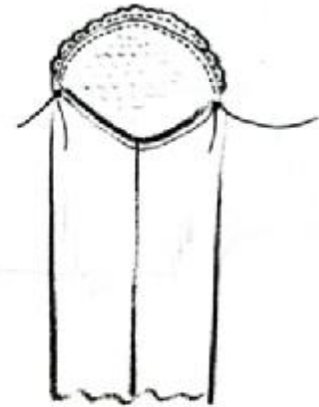

- ③ Iron the sleeves lightly with the steam iron.

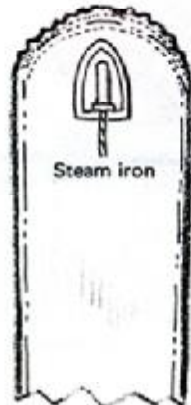

- ④ Turn the bodies and the sleeves inside out and pin the edge of armhole as shown in the diagram.

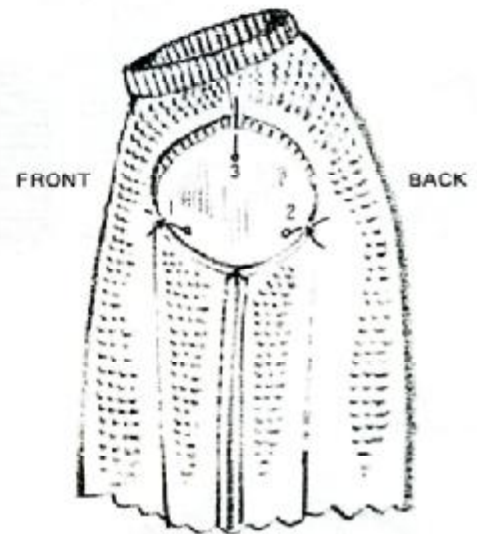

- ⑤ Baste the sleeves to the armholes with the basting thread.



- ⑥ Sew the basted part with the sewing machine.

13 Knitting Stitches

Garter stitch knitting

① Knit two rows and change the last row of stitches to plain stitches with the latch tool as shown in the diagram.

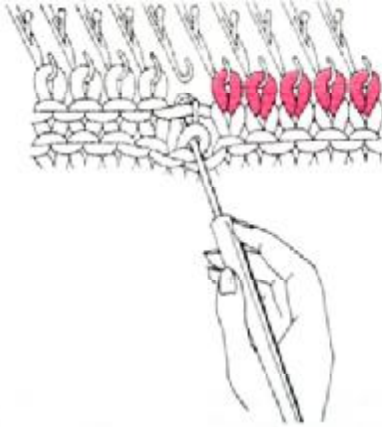

② Repeat these steps, you are doing garter stitch knitting.

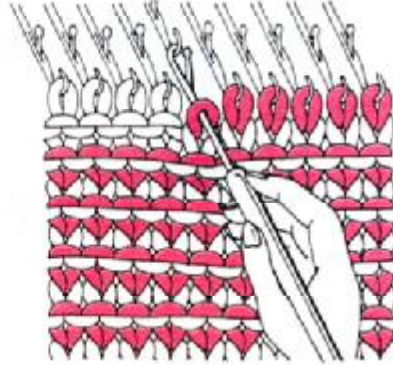

Moss stitch knitting

① Knit two rows and change every other stitch to a plain stitch with the latch tool as shown in the diagram.

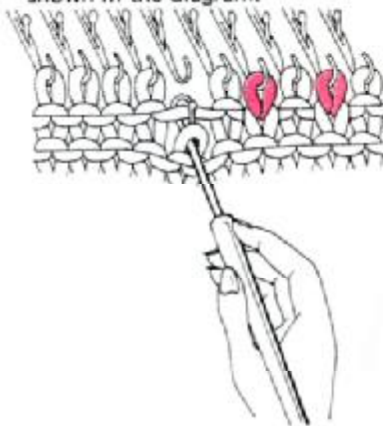

② Knit one row and change the other stitches to plain stitches with the latch tool as shown in the diagram.

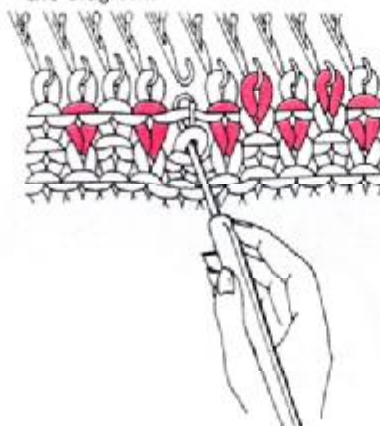

③ Repeat these steps, you are doing moss stitch knitting.

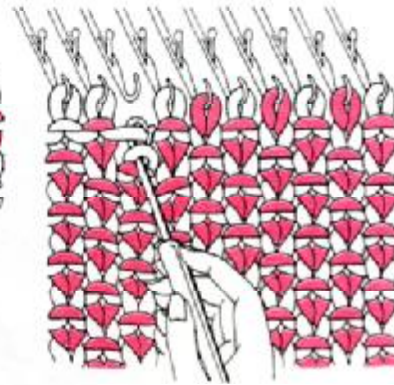

Open stitch pattern knitting

When you start open stitch pattern knitting from the beginning, push back the needles which are to be opened to position A. If you start the open stitch knitting after you have knitted several rows transfer the stitches to the adjacent needles and return the empty needles to position A.

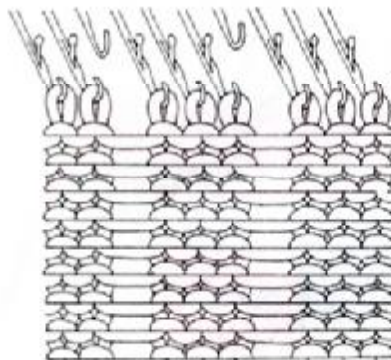

Cable stitch knitting (More than four stitches)

5×5 cable stitch knitting with the multi-transfer tool

Adjusting transfer tool

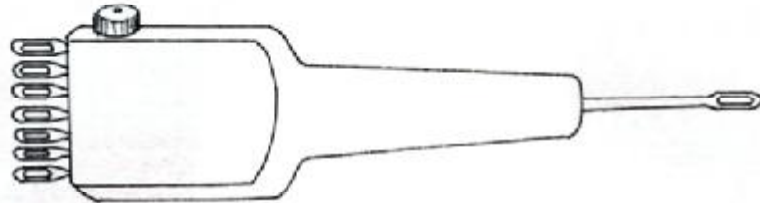

- ① Knit up to the cable stitch knitting point and bring forward ten needles to position D. (Pass all the stitches over the needle latches.) Take the length of the main yarn about eight times the width of the knitting. Lay the separate yarn (same colour yarn) on the hooks of the needles and push back the needles one by one to position A manually as shown in the diagram.

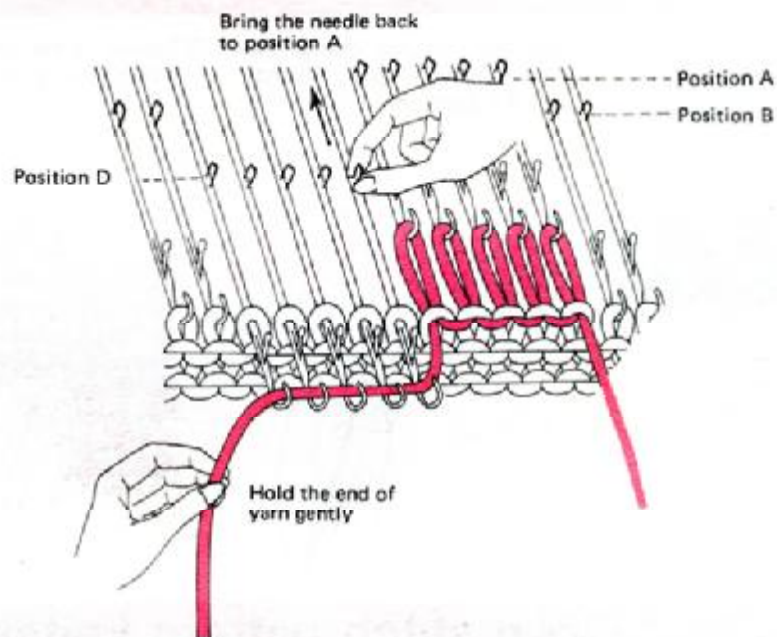

- ② After knitting ten needles by hand, align these ten needles in position B and hang the claw weigh on this part as shown in the diagram.

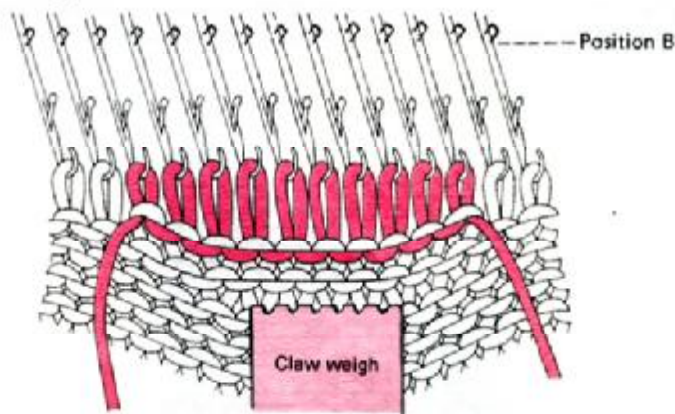

③ Transfer these ten stitches to the multi-transfer tool (five stitches each) as shown in the diagram.

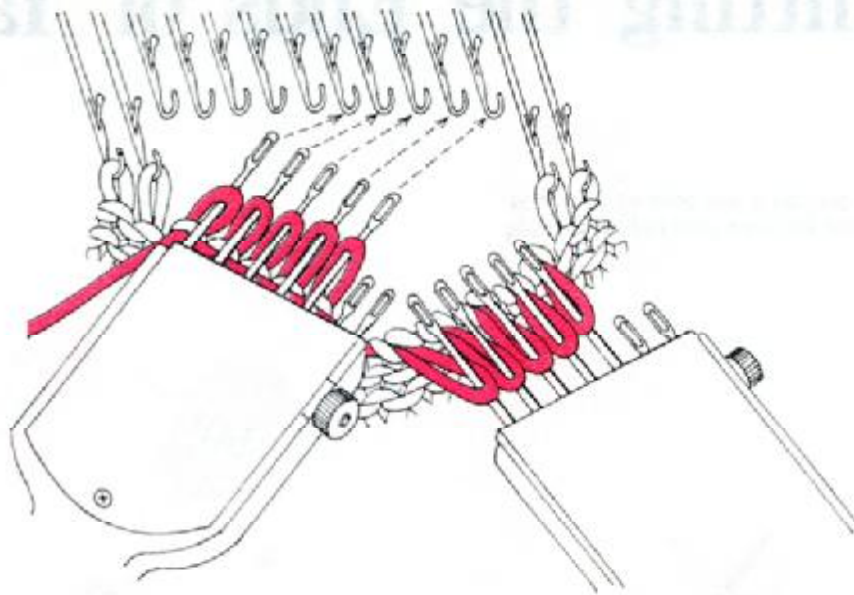

19.07
Always cross in the same direction.

④ Cross these stitches as shown in the diagram and return them onto the hooks of needles.

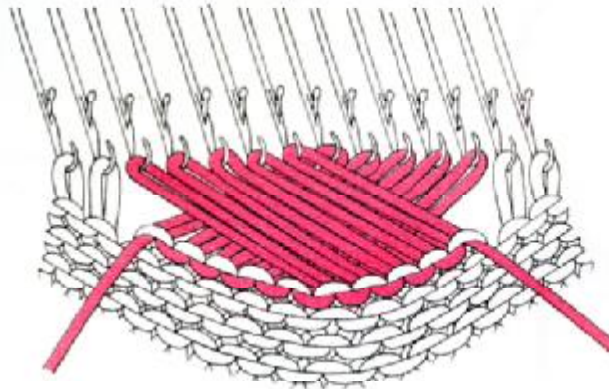

⑤ Repeat these steps to make cable stitch knitting. After knitting, sew the yarn end into the stitches on the wrong side of the swatch as shown in the diagram.

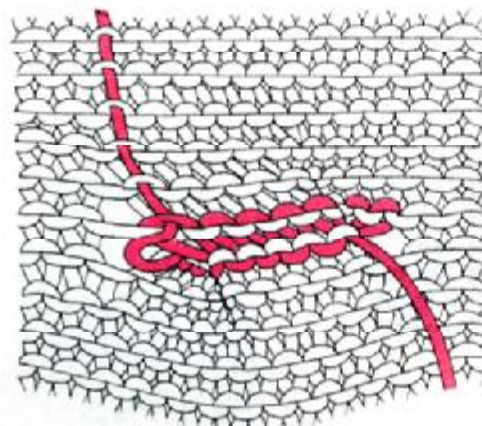

14 Knitting the Ends of Yarn

When you are using the balls of yarn, it is better to knot the yarn ends before knitting.

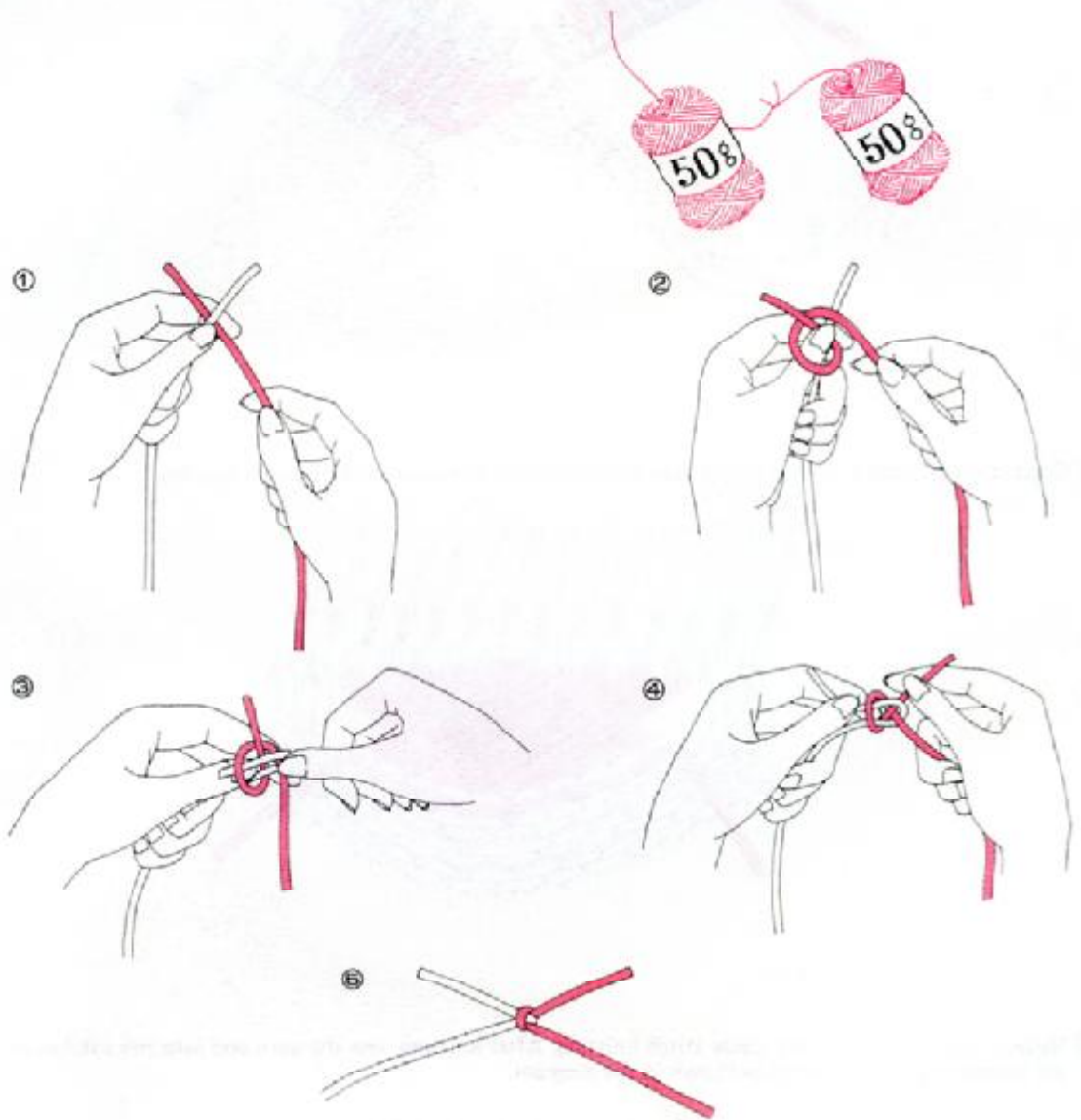

When you are knitting the garment, it is better to knot the yarn ends at the edge of the swatch as shown in the diagram.

When the yarn runs out, leave the yarn end about 10 – 15 cm and rethread the new yarn. After knitting, sew the yarn ends into the stitches on the wrong side of the swatch.

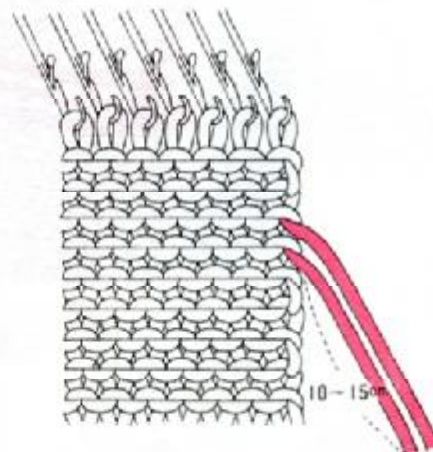

15 Putting in a Yarn Mark (Reference Mark) on the Swatch

A Yarn marker (reference mark) is used to mark a certain point of the knitting for the seams, folding, matching, etc.

In sideways

① Set the weaving pattern levers to position "W.T". Bring forward every other needle to position D and lay the separate yarn on the hooks of the selected needles.

② Knit one row, the separate yarn is threaded through the stitches.

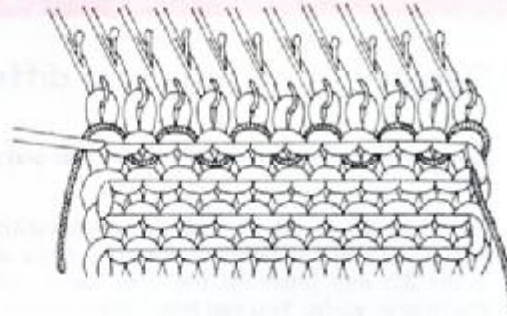
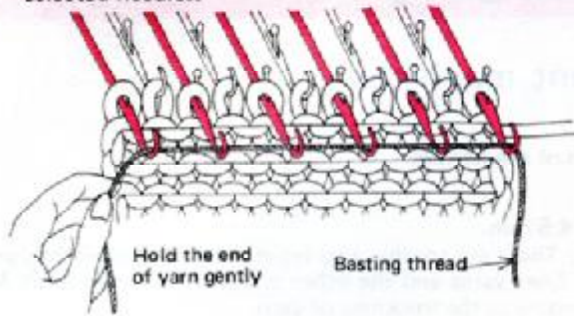

On the edge of the swatch

① Hang the separate yarn on the hook of both end needles as shown in the diagram.

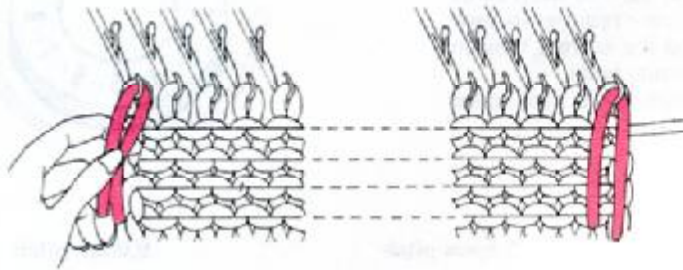

② Knit one row, you can put the yarn mark on the either side of the swatch.

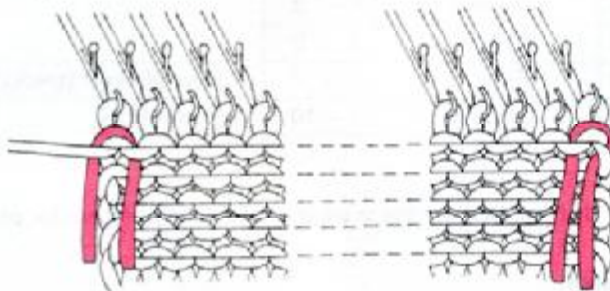

In the middle of the swatch

Put the latch tool into the loop and hook the separate yarn into the hook of the latch tool. Push the latch tool towards the machine so that the separate yarn comes behind the latch, then hook the end of the separate yarn into the hook of latch tool and pull it towards you.

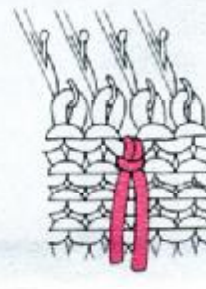
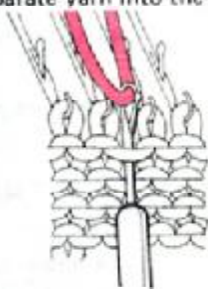

16 How to Adjust a Tension Gauge

Density of stitches and gauge

A) Density of stitches on different machines

Size of the stitches are made by the cams and pitch of the needles.

Normal pitch of the domestic knitting machine is 4.5 mm.

The tension dial determines the size of the stitch. There are another two types of knitting machines, one is the 3.5 mm pitch for the finer yarns and the other one is the 9.0 mm pitch for the thicker yarns. You can select the machine according to the thickness of yarn.

B) Proper tension gauge

There are too many types of yarn to show all of them here and each type of yarn requires its own tension dial number so, find the correct tension dial by referring to the following table. Tension dial is graduated from 0-10, each space being subdivided into three parts.

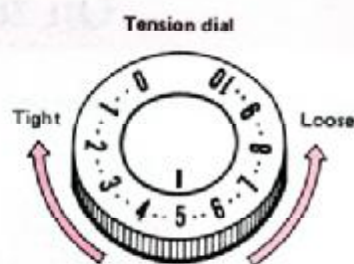

4.5mm pitch		3.5mm pitch		9.0mm pitch	
Very fine	0 - 3	Ultra fine	0 - 1		
Fine	3 - 4	Super fine	1 - 3		
Medium	4 - 6	Very fine	3 - 5		
Thick	6 - 9	Fine	5 - 7	Double knit (thick)	4 - 8
Very thick	9 - 10	Medium	7 - 10	Ultra thick	8 - 10

※ These tension dial numbers are the average tension dial numbers for plain knitting.

How to determine the tension gauge.

(4.5mm/3.5mm pitch)

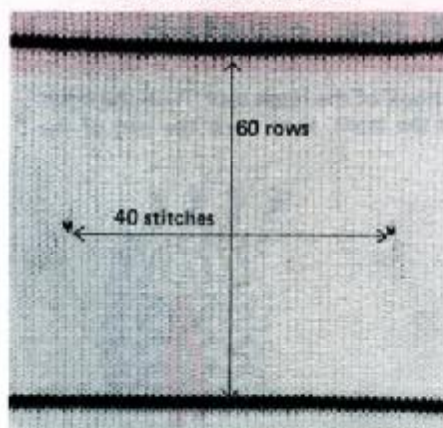

(9.0mm pitch)



(4.5mm/3.5mm pitch)

60 rows
13.2 cm

T.D.5

40 stitches 13.7 cm

(9.0 mm pitch)

30 rows
13.0cm

T.D.6

20 stitches 12.4cm

Cast-on with sixty needles and set the tension dial to a higher number, then knit thirty rows.

After knitting the first thirty rows, set the tension dial 0.2 numbers lower than first tension and knit another thirty rows.

Repeat these steps to the lowest tension dial number.

(When you change the tension dial, make a hole at the center to find the changing point, by transferring stitch). After knitting, take the swatch off themachine and leave it on a flat table.

Iron the swatch lightly with a steam iron.

Take a measurement of 40 stitches according to the part of the garment, where the tension changes. Find the required amount of needles with the proper stitch measure scale and determine the required rows based on the length of the tension swatch.

※ It is better to make the tension swatch double the length to take more accurate measurement

Tension swatch

Drawing

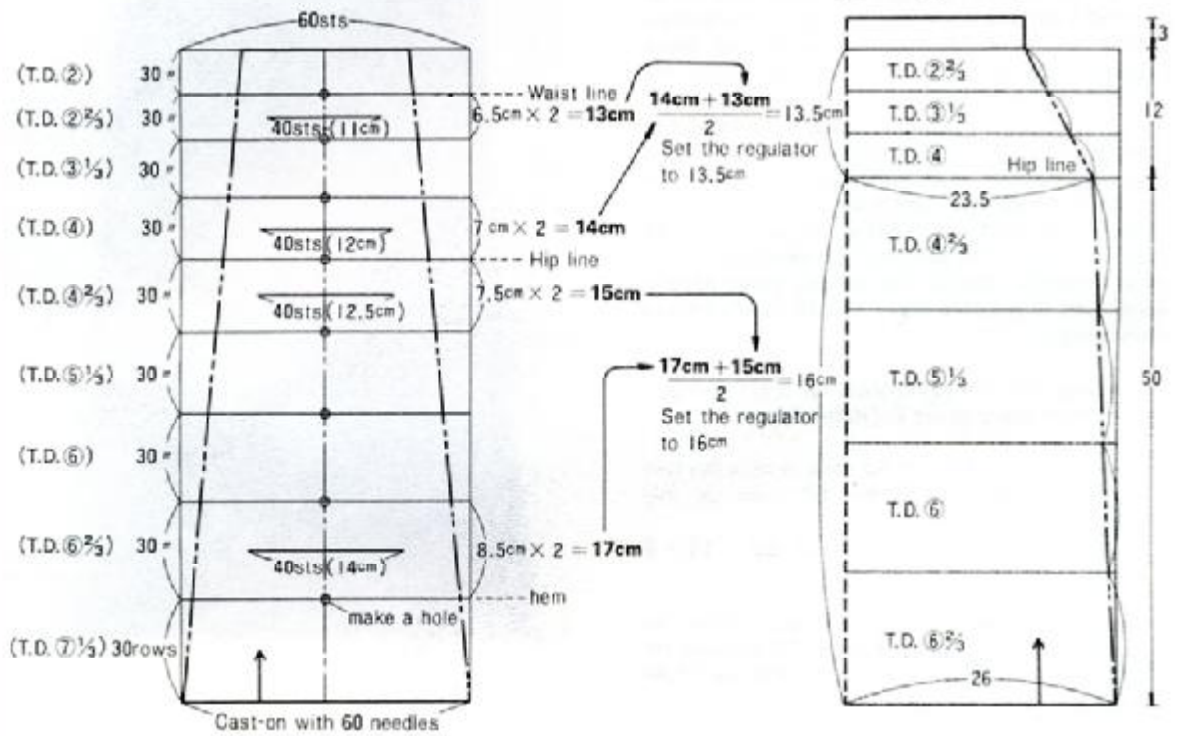

Knitting with machine

To fit the garment perfectly.



To keep the shape better.



Using on parts of a garment.



17 Cord Knitting

Cord knitting with machine

A) With three stitches

Cast-on (1)

Bring forward three needles to position 'E' and loop the yarn around the needles as shown in the diagram. Pass the yarn under the right end needle. Place the yarn in yarn feeder 'A' and continue to knit. For the first few rows of cast-on, bring all the needles to 'E' position each row.

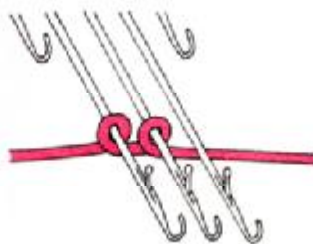

Cast-on (2).

① Make a loop with the transfer tool as shown in the diagram.

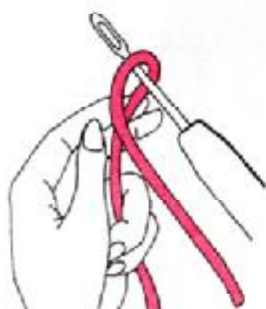

② Pass the yarn through the loop.

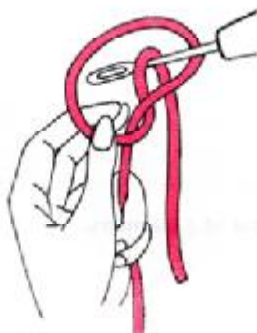

③ Hook the yarn onto the hook of the needle, as shown in the diagram.



④ Pick up the yarn with the transfer tool, as shown in the diagram.

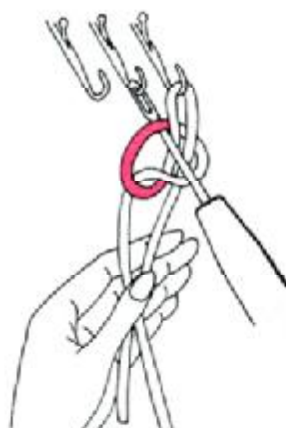

⑤ Pull down on the end of the yarn.

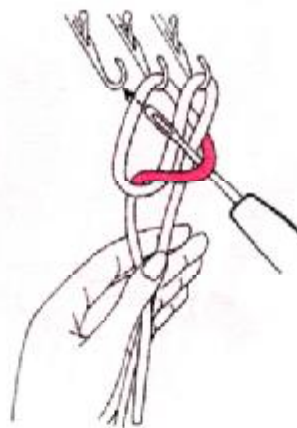

Cast-on (3).

① Make a loop with the yarn end and thread it through the needle as shown in the diagram.

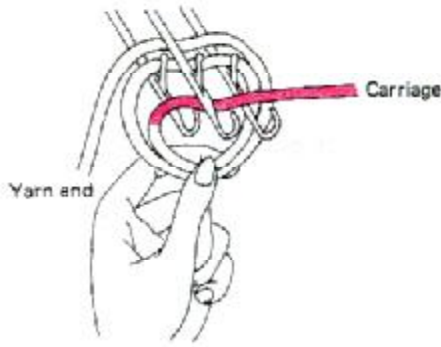

② Knit both end needles by hand.

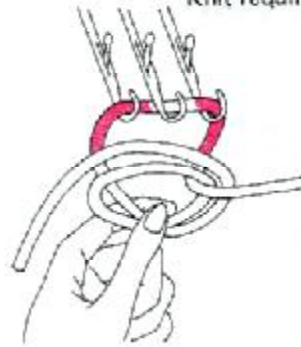

③ Pick up the yarn which was passed under the centre needle with the transfer tool and hook it onto the hook of the centre needle as shown in the diagram. After casting-on, push right "PART" button and bring forward three needles to position E. Knit required length of cord.

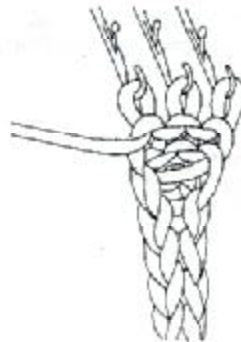
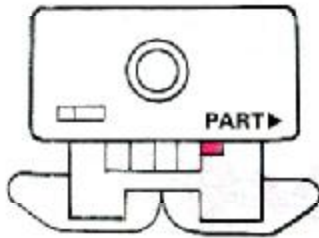
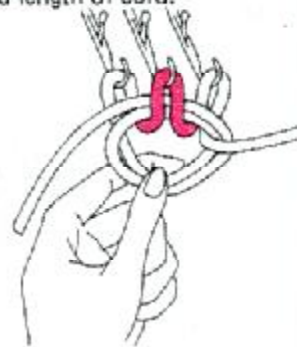

B) With five stitches

Cast-on five needles using method A) cast-on (1) on page 76. Push right "PART" button and knit required length of cord. Make a rib stitch by picking up the slipped thread with the latch tool as shown in the diagram.



C) With seven stitches

① Cast-on seven needles with the waste yarn and knit several rows. Knit one row with the cast-on thread and place the K carriage on the right side of the machine. Push the right "PART" button.

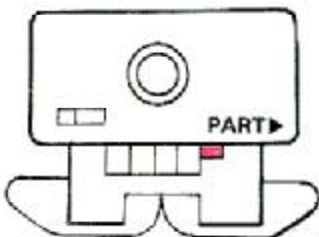

② Knit one row to the left. Bring forward the centre needle to position D and knit one row to the right. Repeat these steps.

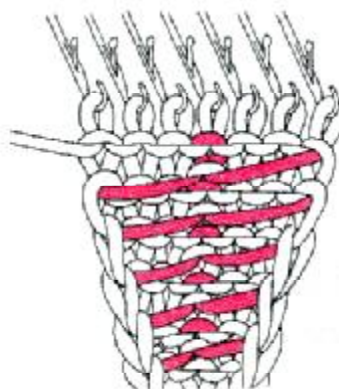

Cord knitting with crochet hook

A) Chain stitch

Make a chain stitch with the crochet hook as shown in the diagram.

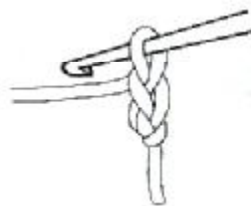

B) Double chain stitch (1)

① Cast-on with the crochet hook and make a chain stitch, then pick up the yarn behind as shown in the diagram.



② Drop the stitch and insert the crochet hook into the first stitch, then make a chain stitch as shown in the diagram.



③ Insert the crochet hook into the dropped chain stitch and make a chain stitch as shown in the diagram.



④ Repeat these steps.



C) Double chain stitch (2)

Make a loose chain stitch with the crochet hook. Picking up the back of the stitch to make a chain stitch as shown in the diagram.

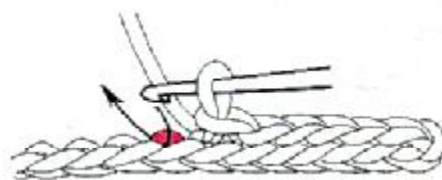
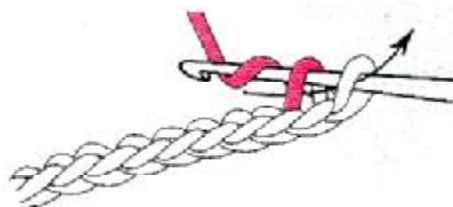

Small size buttonhole

A) Plain knitting (1)

① Knit up to the buttonhole point and transfer the stitch to the adjacent needle with the transfer tool as shown in the diagram.

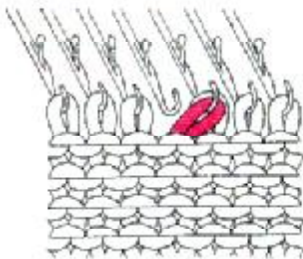

② Continue to knit, small size buttonhole is completed.

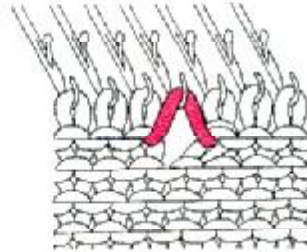

B) 1 x 1 rib

① Knit up to the buttonhole point and make a 1x1 rib with the latch tool. Then, transfer last rib stitch to the adjacent needle as shown in the diagram.

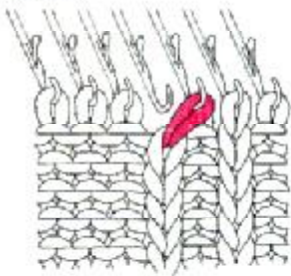

② Continue to knit and resume making the 1x1 rib.

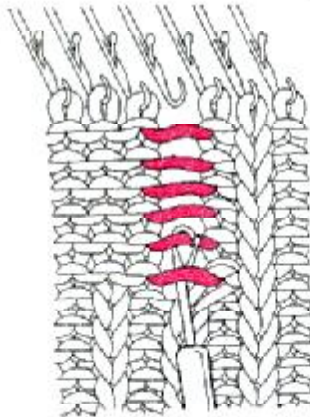

③ After knitting, sew blanket stitch around the hole on the front side of the swatch with the tapestry needle.

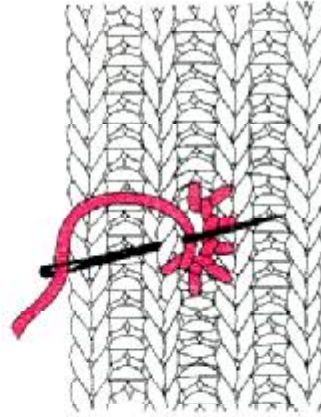

C) Plain knitting (2)

① Knit up to the buttonhole point and transfer the stitches to the adjacent needles as shown in the diagram.

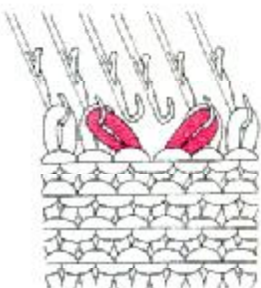

② Knit one row and hang the yarn on one empty needle as shown in the figure.

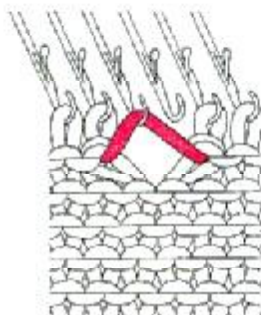

③ Knit another row.

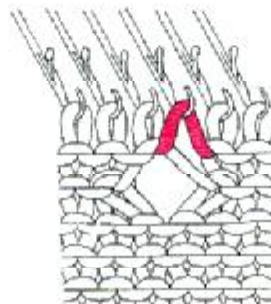

④ Pick up the lower thread and hook it onto the hook of the needle as shown in the diagram.

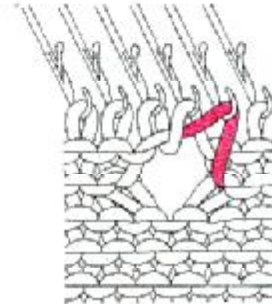

⑤ Continue to knit. After knitting, sew blanket stitch on the front side of the swatch with the tapestry needle.

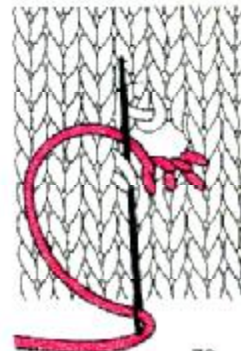

① Knit half of the front side of the band. Using a separate piece of yarn, knit the required needles for the buttonhole by hand as shown in the diagram.

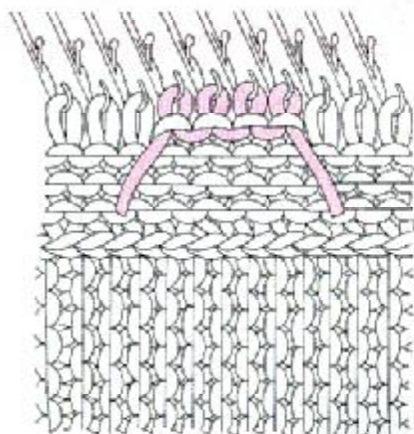

② Knit the other half of the front side of the band and half of the back of the band. Bring forward the same number of needles as previously on waste yarn and one more needle on the left side to position D as shown in the diagram.

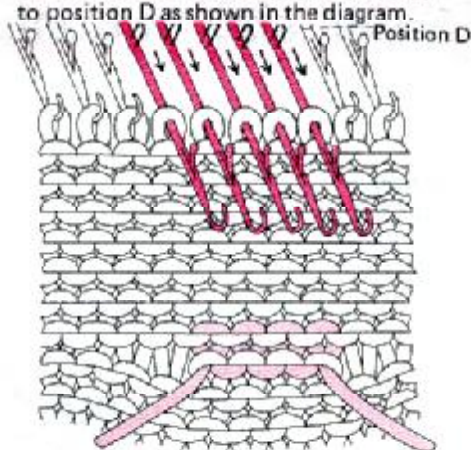

③ Using the transfer tool, pick up all the sinker loops on waste yarn and hook them onto the D position needles as shown in the diagram.

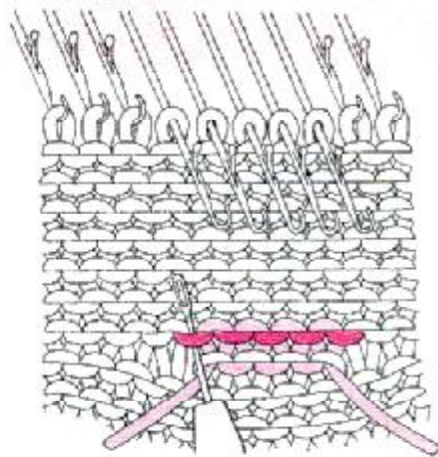

④ Push back the needles one by one to position B manually so that the stitches go over the latches.

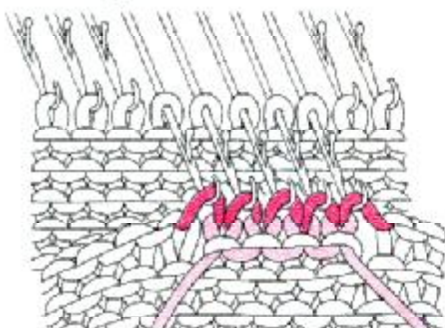

⑤ Single stitches are made.

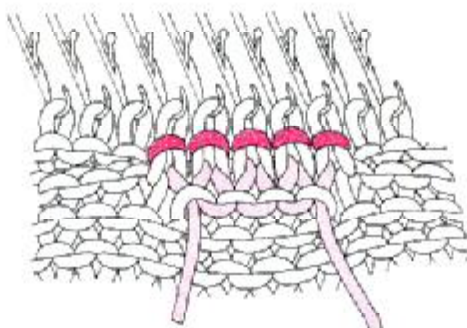

⑥ Transfer the second stitch from the right of the buttonhole to the right end needle of the buttonhole with the transfer tool as shown in the diagram.

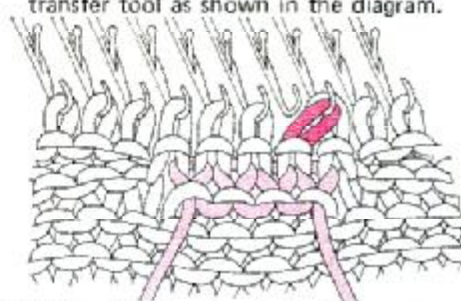

⑦ Transfer these two stitches to the inside empty needle with the transfer tool.

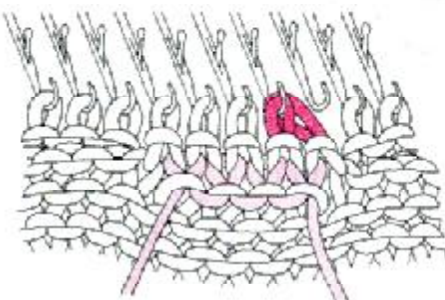

⑧ Slide the back stitch behind the latch and make a single stitch by hand. Repeat these steps ⑥-⑧, at the left end, hook the stitch onto the hook of needle as shown in the diagram.

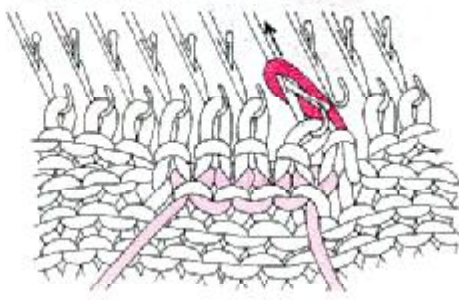

⑨ Using the transfer tool, pick up the needle loops on the lower rows of the waste yarn and hook them onto the empty needles as shown in the diagram. To avoid a hole, pick up the right adjacent needle loop of the button hole and hook it onto the hook of the needle as shown in the diagram.

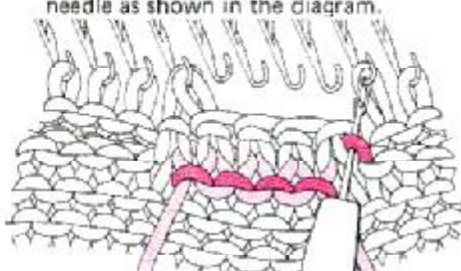

⑩ After picking up all the needle loops.

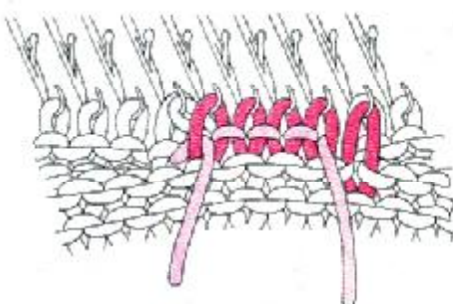

⑪ Knit the other half the back of the band. After knitting, take the waste yarn out.

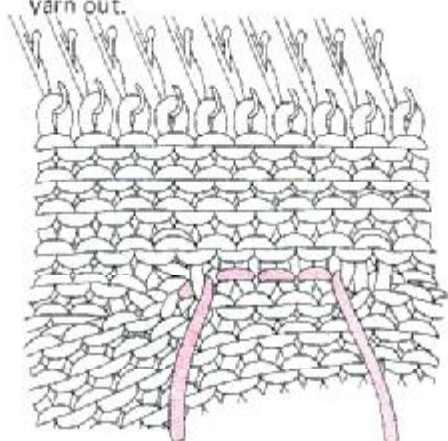

⑫ Now, the horizontal buttonhole in the folded band is completed.

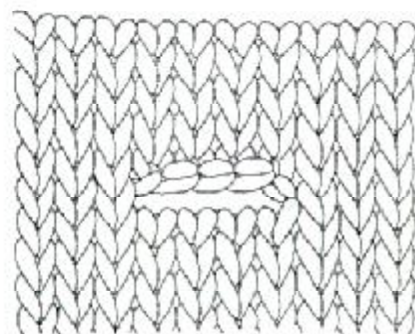

Vertical buttonhole

① Knit up to the buttonhole point. At the opposite side of the K carriage, bring forward all the needles from the buttonhole position to the end needle of the swatch to position E.

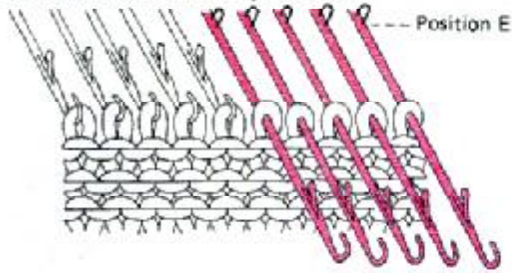

② Set the holding cam lever to position "H" (Push button machine to II) and knit required rows for the length of the buttonhole.

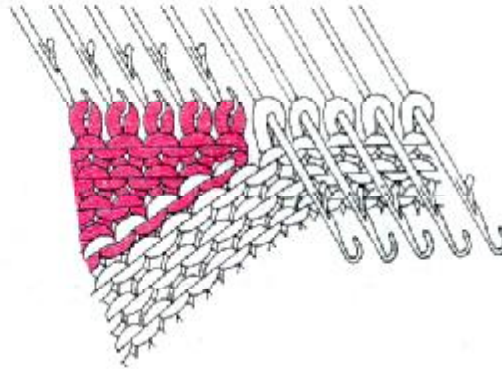

③ Place the K carriage on the opposite side and bring forward all the needles which are already knitted to position E. Push back all the needles which have been placed in position E to position D.

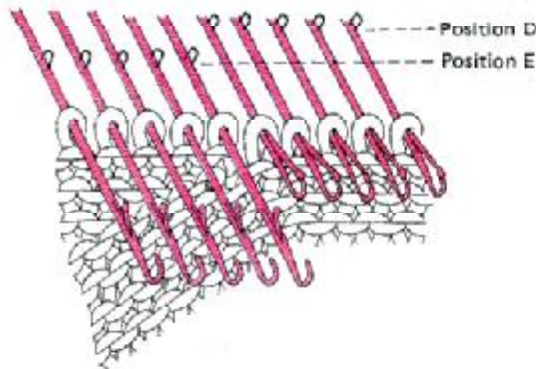

④ Knit the same number rows as the first side.

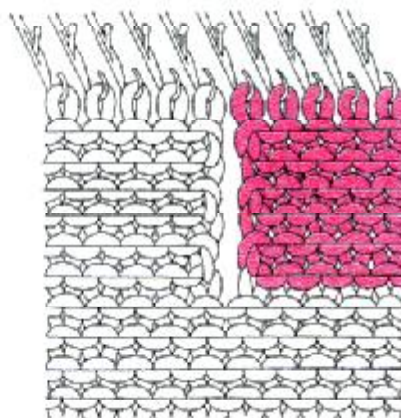

⑤ Reset the holding cam lever to position "N". (Push button machine to I)

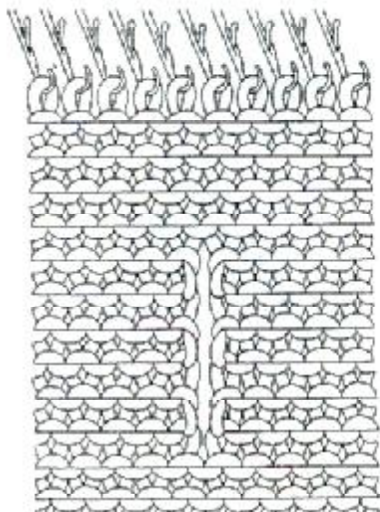

⑥ After knitting, sew blanket stitch on the front side of swatch with the tapestry needle as shown in the diagram.

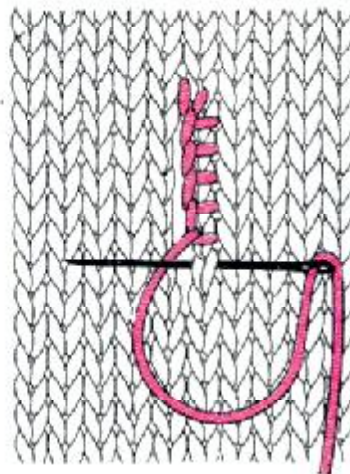

Buttonhole by hand

① On the front side of the ribbed knitting, insert the crochet hook into the stitch and pull it at the buttonhole point as shown in the diagram.

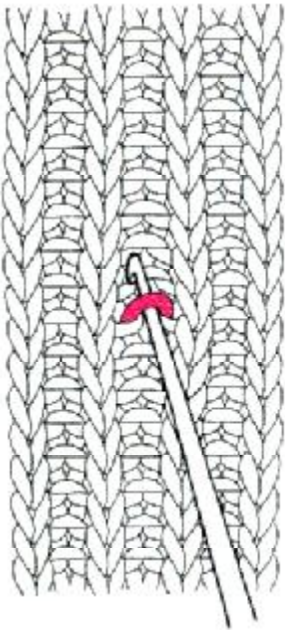

② Repeat this for four rows above and below.

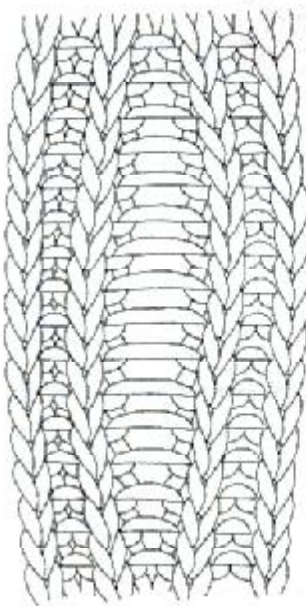

③ Turn over the swatch. Insert the latch tool under the thread at the centre of the buttonhole as shown in the diagram.

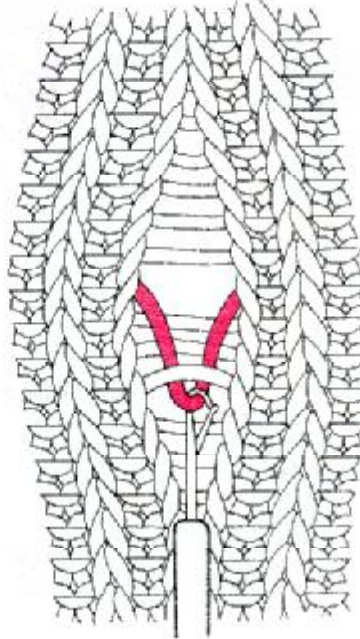

④ Hook the thread with the latch tool as shown in the diagram.

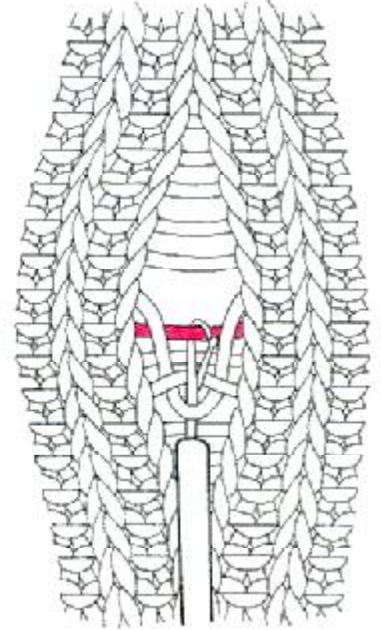

⑤ Pull the latch tool through the stitch which is on the stem of the latch tool.

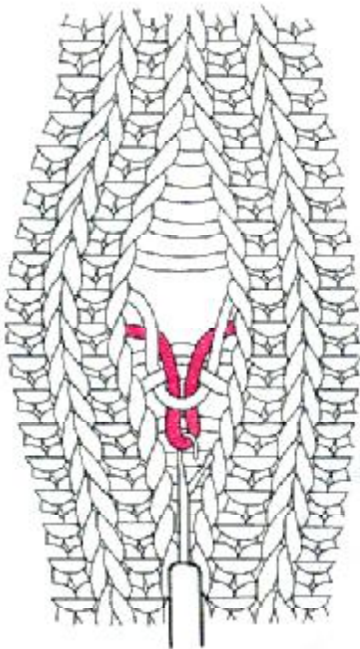

⑥ Do the same operation as in item ④ and ⑤, two more times.

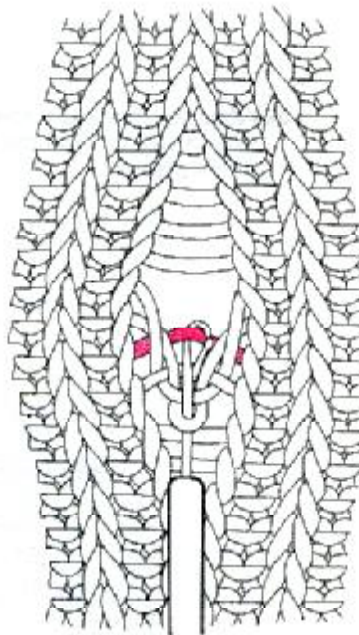

⑦ Pull the latch tool down and insert the tapestry needle with the yarn into the stitch as shown in the diagram.

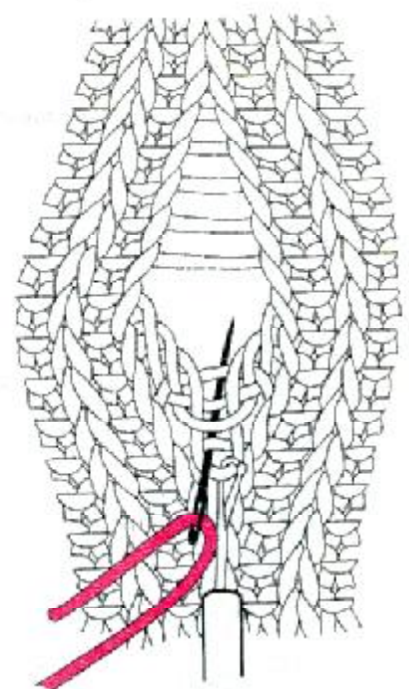

⑨ Take out the latch tool and pass the tapestry needle through the same stitch as shown in the diagram.

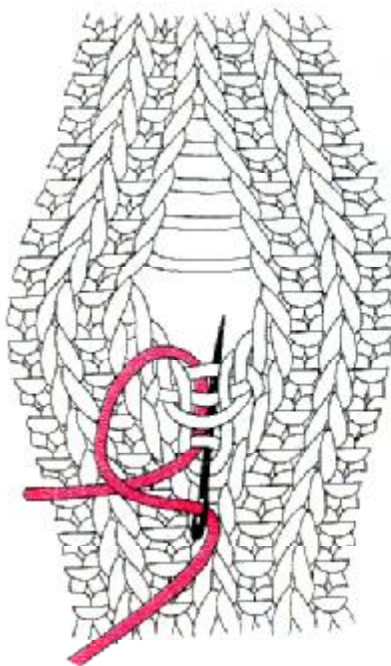

⑩ Pull both ends and tie them together



⑪ Thread both ends of the yarn into the tapestry needle and pass it through the stitch as shown in the diagram.

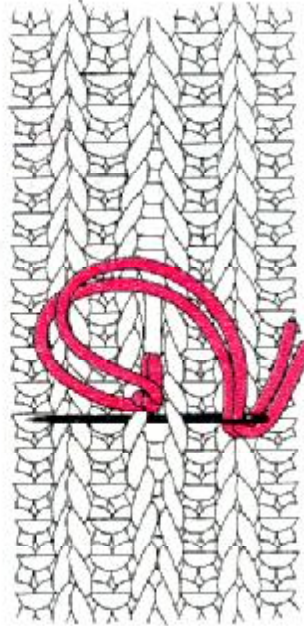

⑫ Sew the end of the yarn into the stitches as shown in the diagram.



⑬ Take the tapestry needle out, the first side of the buttonhole is finished.

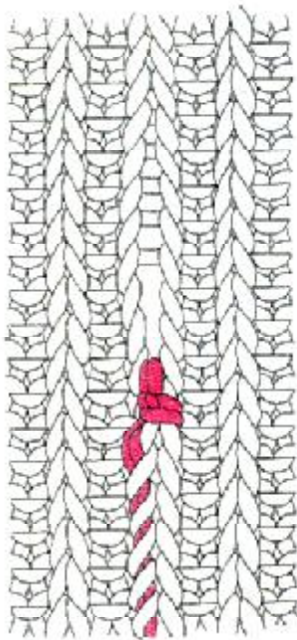

⑭ Do the same operation on the opposite side.

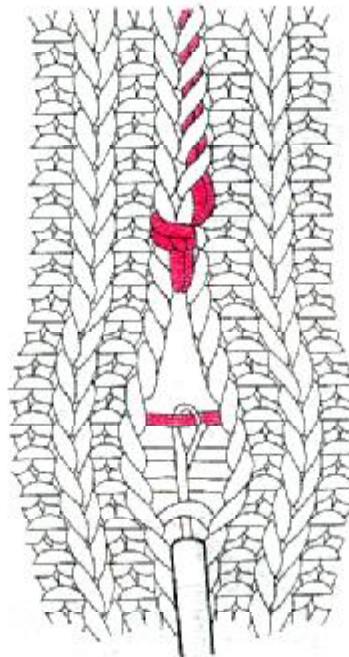

⑮ Now, the buttonhole is completed.

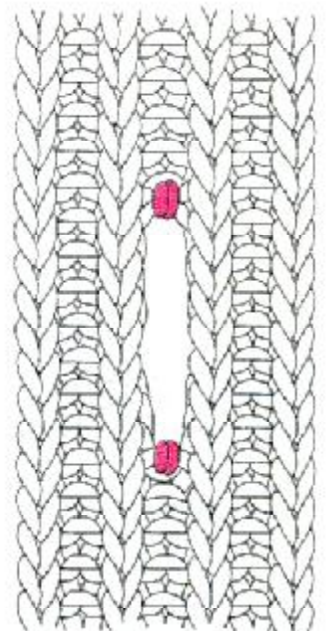

A) Crochet stitch

① Crochet the edge of the garment to the buttonhole point, and make a loop for the button with chain stitches.

② Crochet around the chain stitches as shown in the diagram and continue to crochet to the edge of the garment.

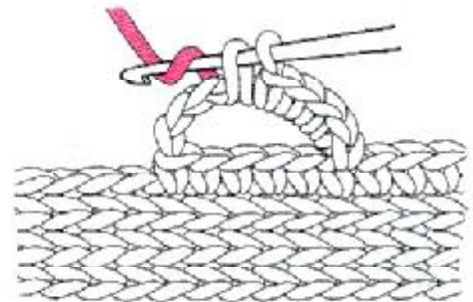
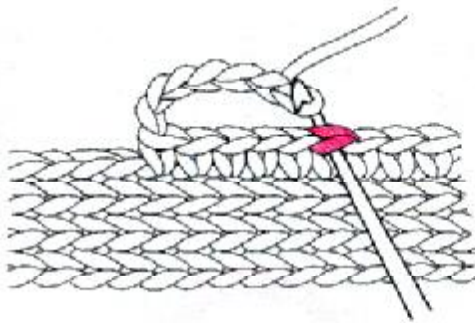

③ Now, the loop buttonhole is completed.

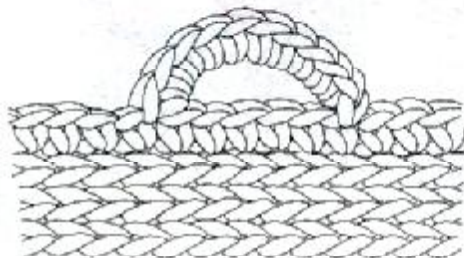

B) Double chain stitches

① Crochet the edge of the garment and make a loop for the button with chain stitches. Make the chain stitches by picking up the back stitch of the first chain stitch as shown in the figure. Then, continue to crochet to the edge of the garment.

② Now, the double chain stitch buttonhole is completed.

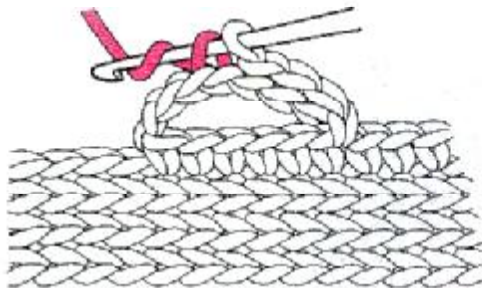

C) Yarn loop

① Using the same yarn as the garment, make two or three loops for the button as shown in the diagram.

② Sew blanket stitches around these yarn loops with the tapestry needle as shown in the diagram.

③ Now, the buttonhole is completed.

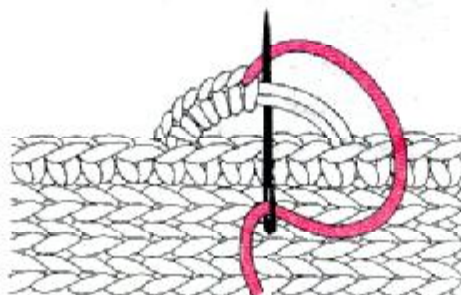
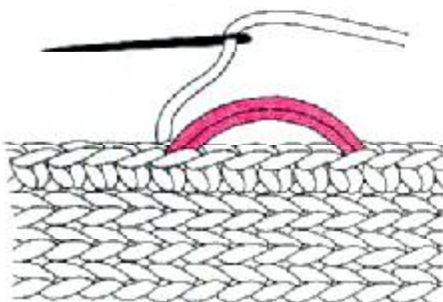

Sewing in yarn ends

A) Cast-on and cast-off edges

Thread the yarn end into the tapestry needle and pass it through the end stitches as shown in the diagram then cut the yarn end. If the yarn end is too short, pass the tapestry needle into the end stitches first, then thread the yarn end into it, and pull it through.

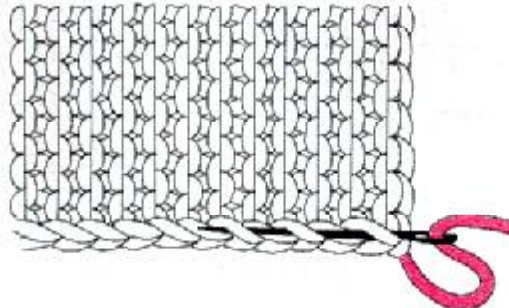

B) On the edge of swatch

When the yarn runs out, leave about 10 cm–15 cm end and rethread the new yarn into the yarn feeder. After knitting, tie both yarn ends together and sew them into the edge stitches with the tapestry needle as shown in the diagram.

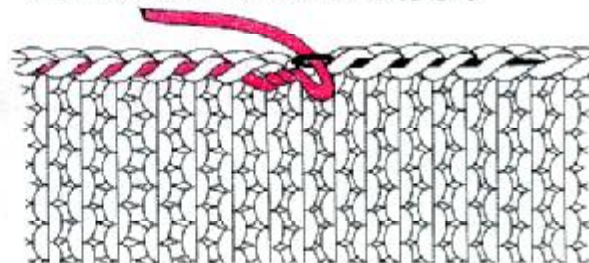
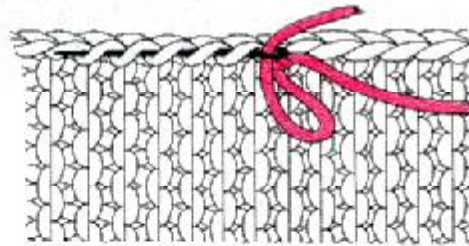
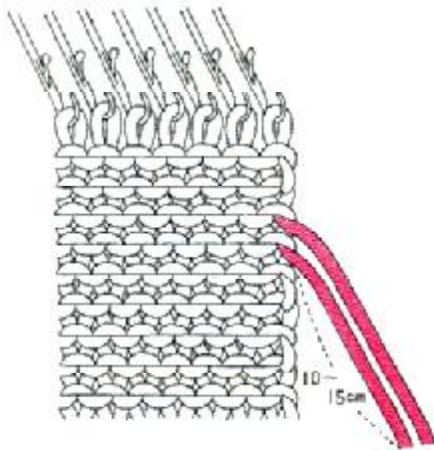

C) In the middle of a swatch

Pick up half of the stitches with the tapestry needle and thread the yarn end into it, pull out the tapestry needle and cut the yarn end.

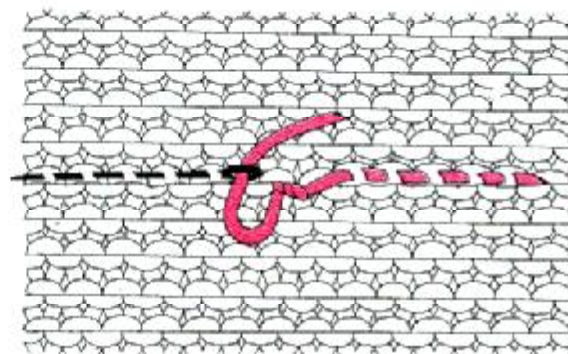
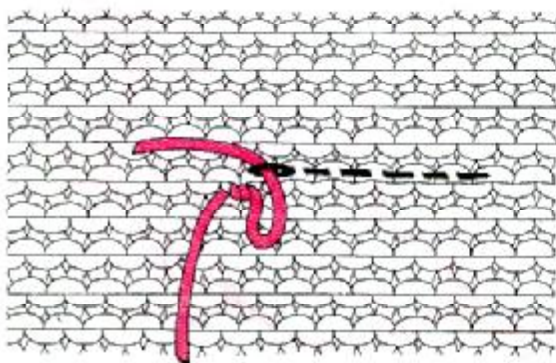

Pick up half of the stitches with the tapestry needle and sew the yarn end into the stitches. Sew the yarn end with the tapestry needles as shown in the diagram.

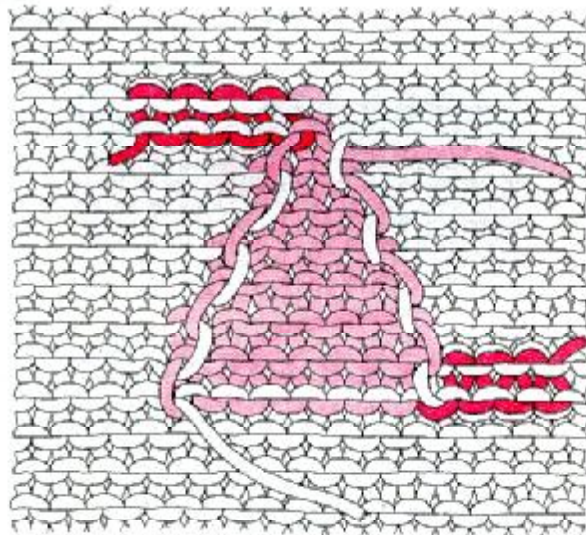
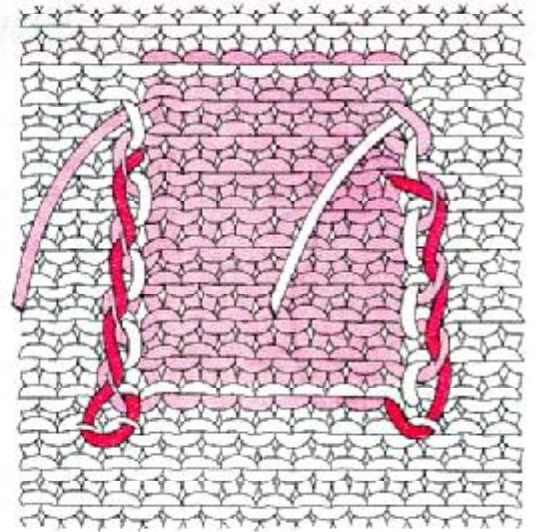
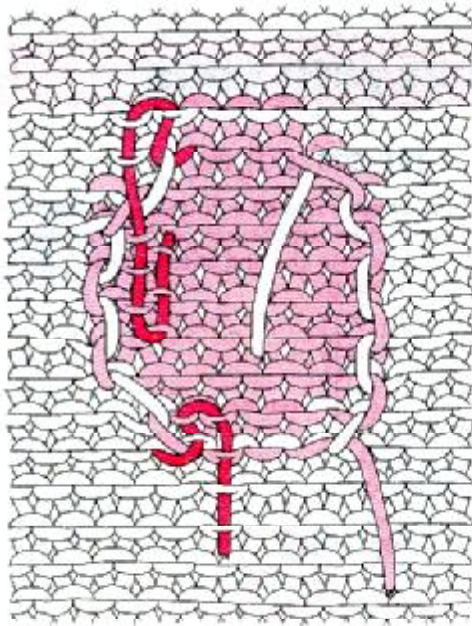

COFFEE BREAK



Ironing is very important to make beautiful shaping.

A) Accessories for the ironing

Steam iron



Blocking pin

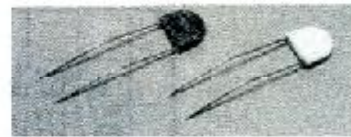
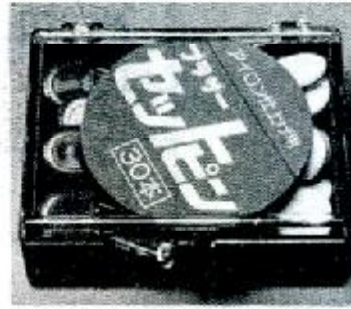

Binding wire

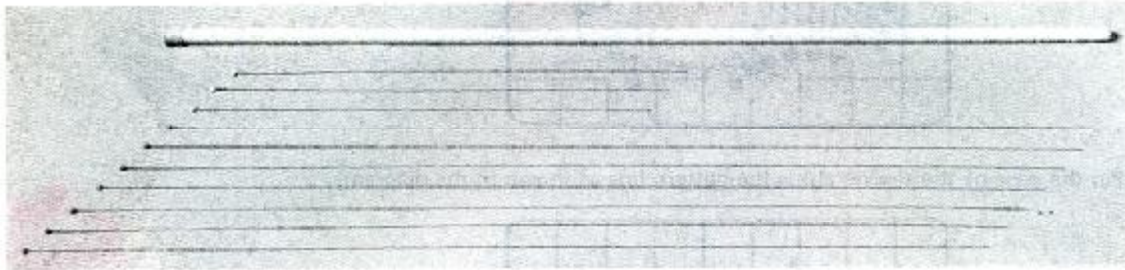

B) Blocking pins and binding wire

- ① Pass the binding wire through the edge stitches as shown in the diagram to spread the swatch edge.
- ② Pin the edge of swatch with the blocking pins as shown in the diagram.
※ Do not press the iron on the head of the blocking pins.

Binding wire

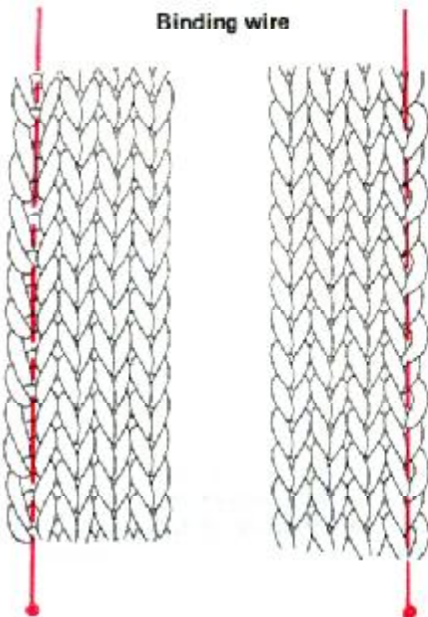

Blocking pin

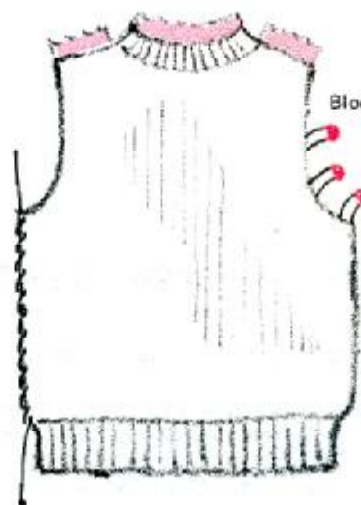

- ① Spread the pattern on the ironing board and spread the swatch on top of it. Using the blocking pins, pin the edge of swatch along the pattern line as shown in the diagram.

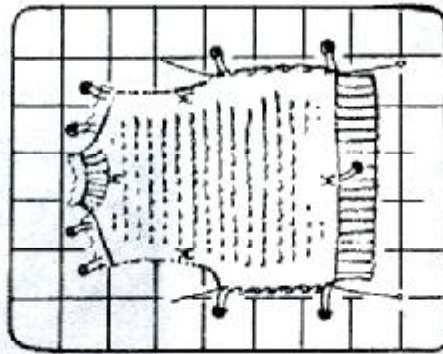

- ② Iron the swatch lightly with a steam iron.

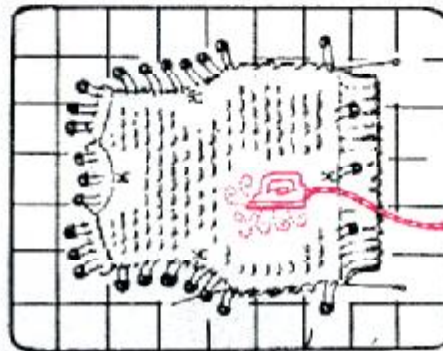

- ③ Pin the edge of the sleeves along the pattern line as shown in the diagram.

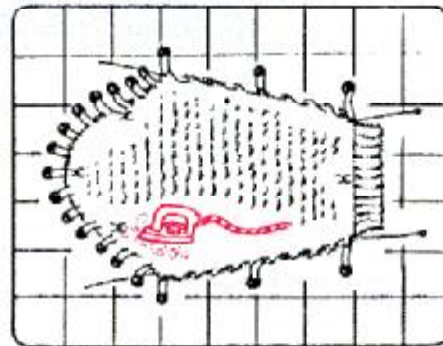

D) Please note the following points when ironing

- ① Do not place the swatches on the transparent sheet for the knit-leader when ironing.
- ② Steam ironing is better for a beautiful finish, however if you use an ordinary dry iron, first dampen a cloth-squeeze it almost dry and place it on top of the swatch then iron lightly and evenly over it.
- * Synthetic fiber yarns usually carry instruction tags which specify appropriate temperature for ironing or prohibiting ironing. In such cases please follow the directions on the tags.

- ① After sewing, iron the swatches lightly with a steam iron as shown in the diagram. At this point, check the size of the swatches with the drawing pattern.

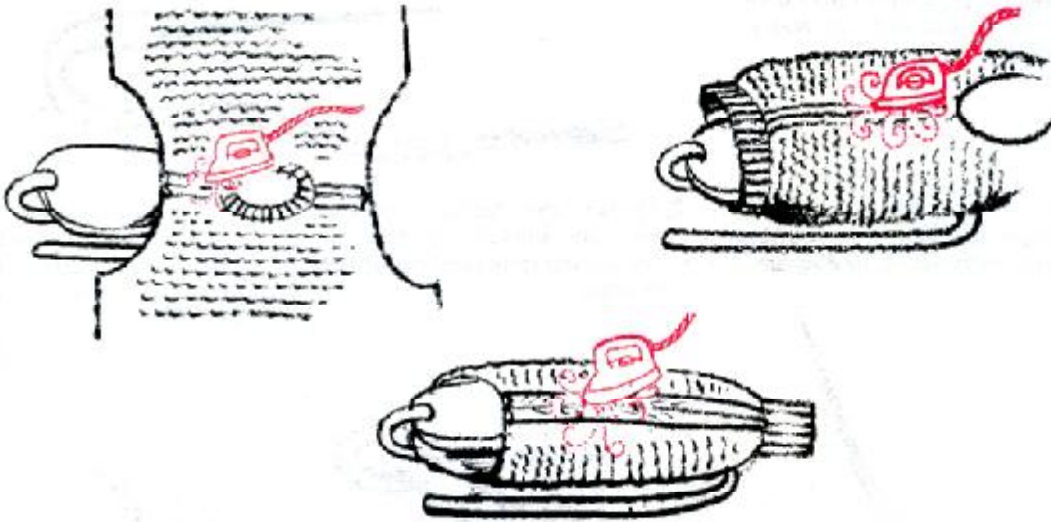

- ② Attach the sleeves to the body and iron the edge of the armholes lightly as shown in the diagram.

- ③ When gathering at the top of a sleeve, place the iron on the gathered part firmly as shown in the diagram. Then use the iron lightly on the front side of the swatch.

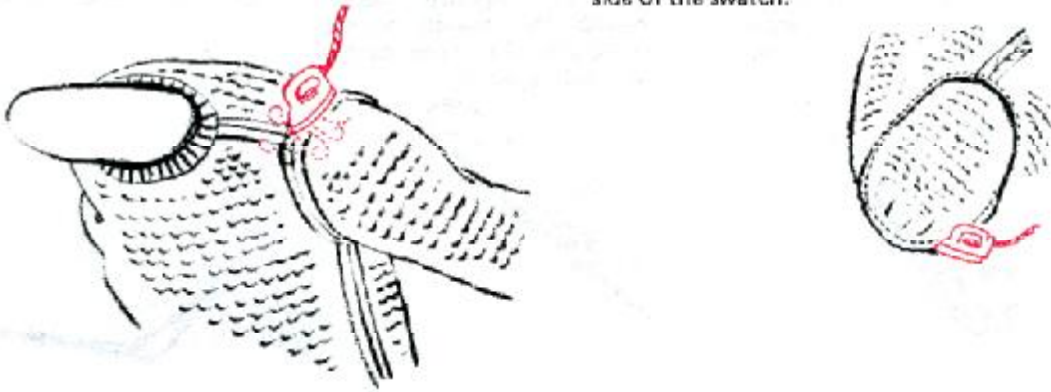

F) Ironing (3)

After finishing the sewing, give the swatch a final ironing from the wrong side lightly. Then, leave the garment as it is until it cools.



A) Bottom button

① Thread the yarn into the tapestry needle and knot the end of the yarn.



② Pass the tapestry needle through the hole of the bottom button as shown in the diagram.



③ Thread the tapestry needle with the bottom button into the button hole position of the swatch.

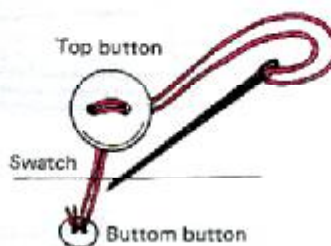

④ Repeat this three or four times and leave on allowance between the button and the swatch as shown in the diagram.

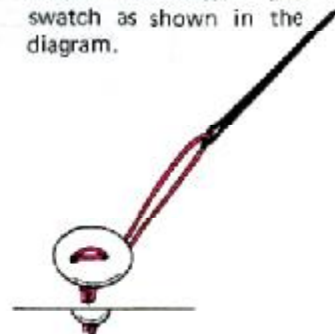

⑤ Wrap the yarn around the allowance yarn two or three times as shown in the diagram.



⑥ Pass the tapestry needle through the swatch to the wrong side of it. Then, tie the yarn ends together.

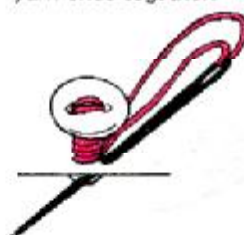

⑦ Cut the yarn with scissors.



B) Attaching reinforcing cloth

① Cut the same colour cloth as the swatch about 0.5 cm bigger than the button size. Attach it on the wrong side of the swatch at the button position.

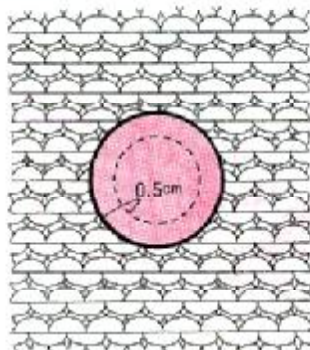

② Attach the button from the front in the same manner as A).

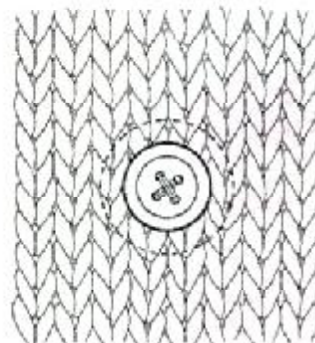

A) Attaching hook (Skirt and pantaloon)

(Skirt and pantaloon)

- ① Attach the hook on to the swatch with buttonhole stitch. Thread the yarn into the tapestry needle and insert it into the hole of the hook from behind the swatch as shown in the diagram.

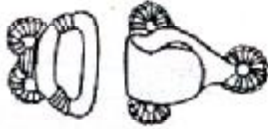

- ② Hook the yarn around the tapestry needle as shown in the diagram.



- ③ Pull the tapestry needle out and repeat this, then tie the yarn ends as shown in the diagram.

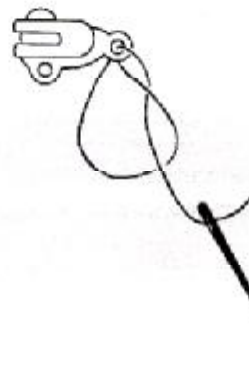

(Pull-over/one-piece)

Attach the hook and eye in the same manner as the above.



B) Attaching press-stud

Attach the press snap onto the swatch as shown in the diagram. This time, insert reinforcing cloth between the press-stud and the swatch.

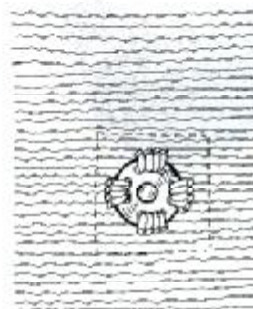
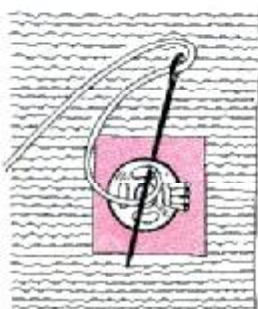

Zip fastener

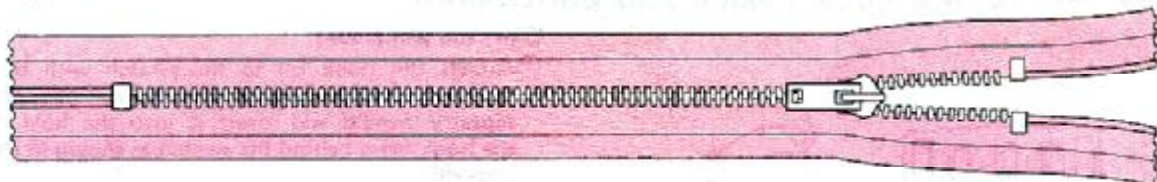

Fastener

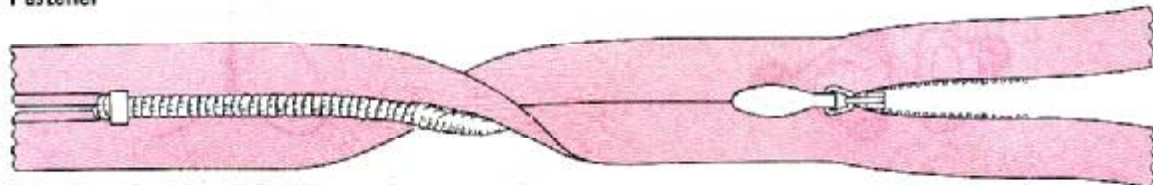

Open fastener

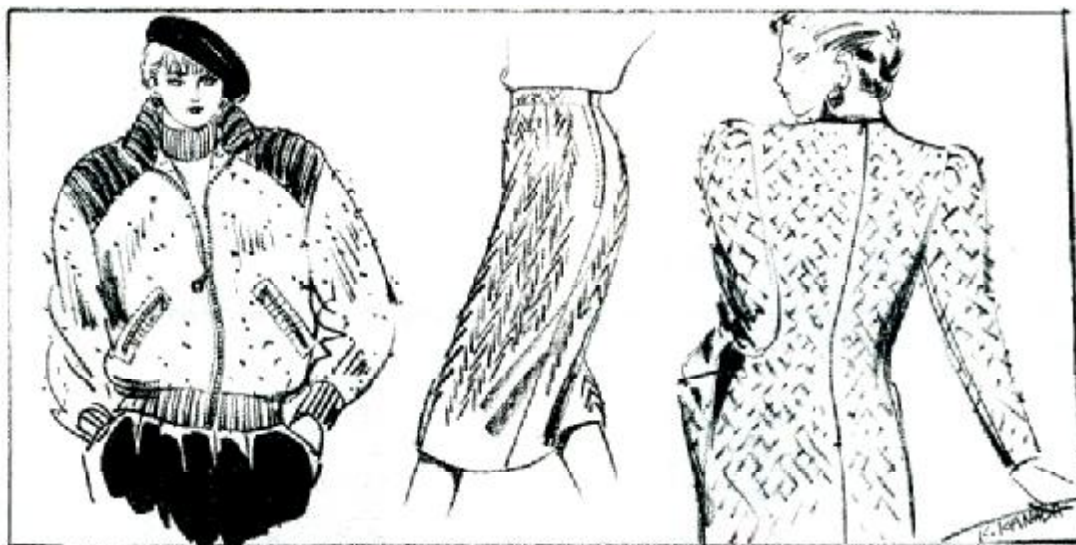
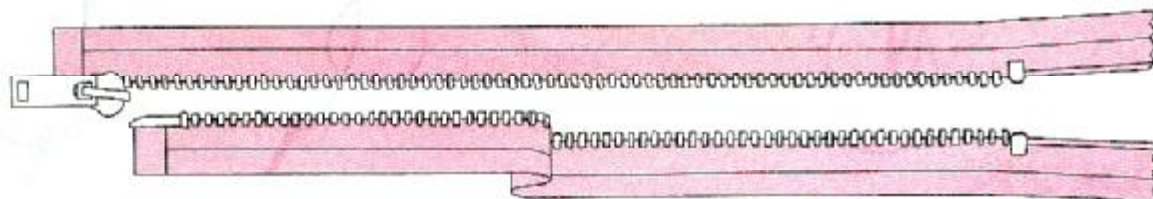

① Make an open stitch pattern on the fifth stitch from the end. (Decide the position of the open stitch pattern according to the materials.)

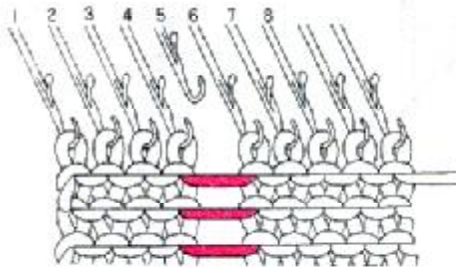

② Knit about 20 rows and make a stitch with the latch tool from behind as shown in the diagram. Repeat this after knitting about 20 rows. This will avoid the stitches stretching.

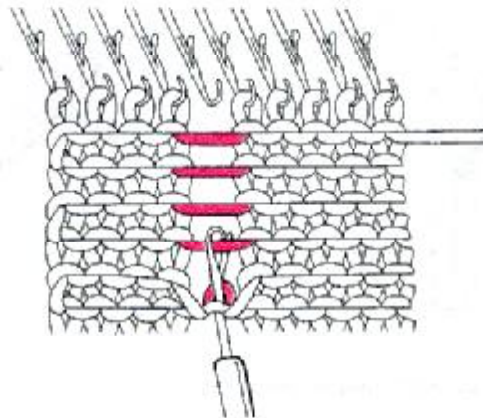

③ For the skirt, transfer the end stitches to the inside after making the new stitches as shown in the diagram.

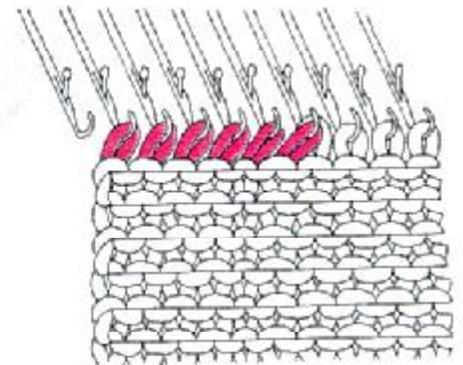

B) Zip fastener

① Crease the attaching point of the fastener according to the pattern size and press with the iron.

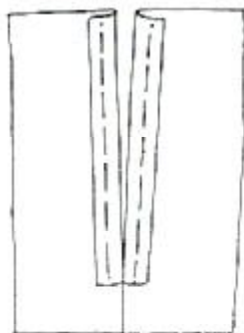

② Put the fastener onto the swatch and baste them with the tapestry needle. Do not stretch the swatch.

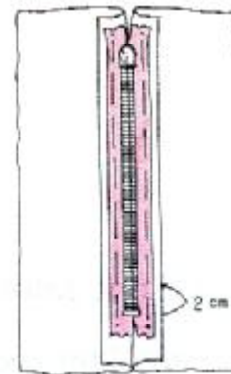

③ Sew the fastener with the sewing machine as shown in the diagram.

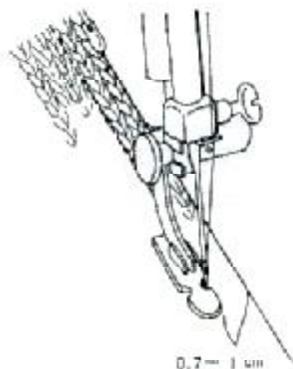

0.7 - 1 cm

④ After finishing the sewing with the sewing machine, finish the end of swatch with the tapestry needle.

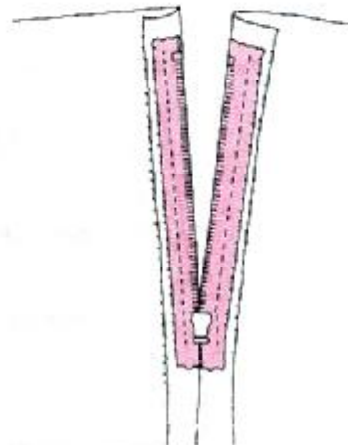
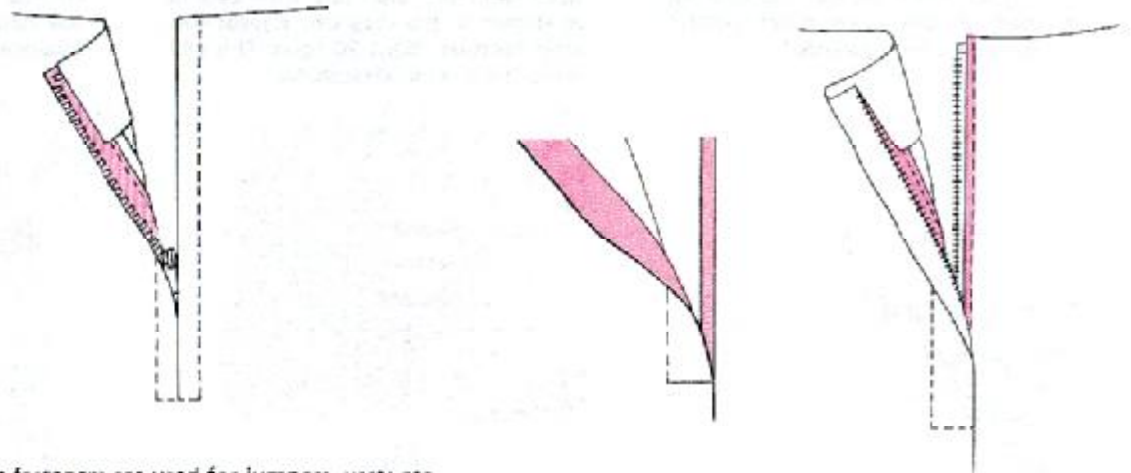
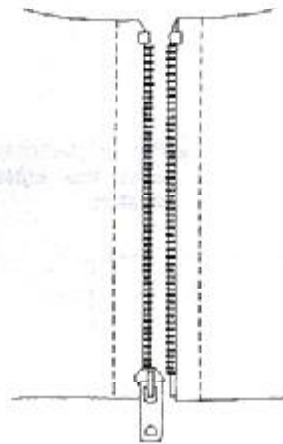

diagram.



Open fasteners are used for jumpers, vests etc.



C) Concealed fastener

Concealed fasteners are not recommended for soft swatches. When sewing the swatch, it is better to use the special presser foot for concealed fastener, as shown in the diagram.



(Skirt)

① Baste the side opening for the fastener with a separate yarn.

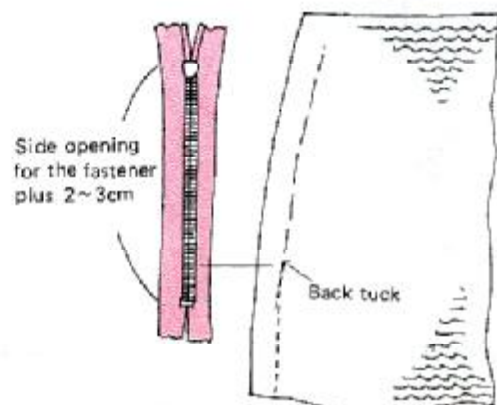
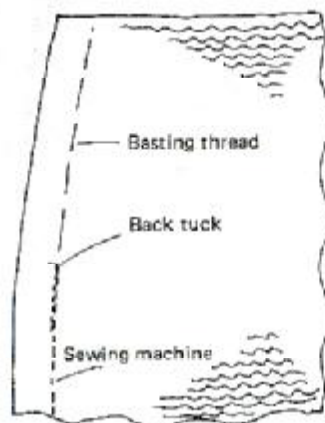

the fastener onto it as shown in the diagram.

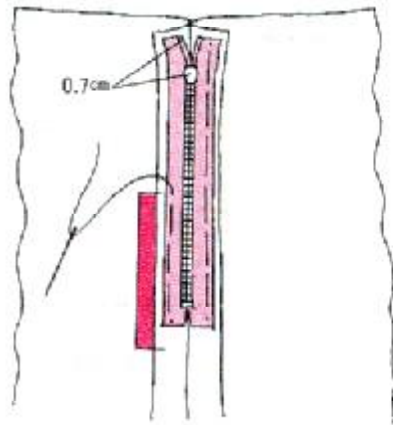

Sew the first side of the fastener with the sewing machine as shown in the diagram.

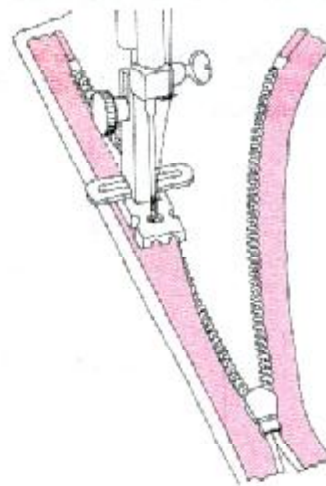

④ Sew the other side of the fastener in the same manner.

⑤ Close the fastener and sew the side with the sewing machine as shown in the diagram.

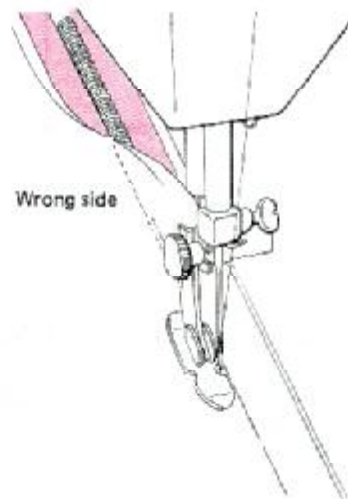
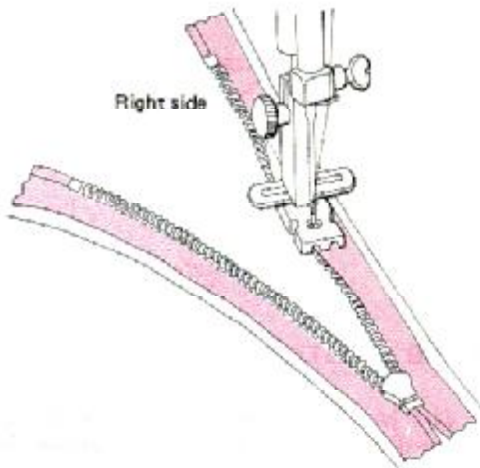

⑥ Sew the side of the fastener to the allowance part of the skirt with the sewing machine.

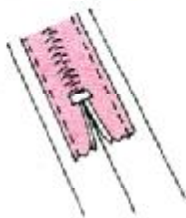

⑦ Open the fastener and sew the upper part of the fastener with the sewing machine.

⑧ Now, the fastener is attached to the skirt.



A) With the tapestry needle

① Fold the inter-facing to the wrong side and attach the strap to the inter facing as shown in the diagram.

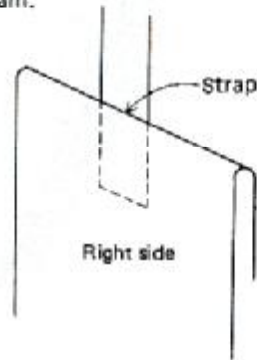

② Sew the edge of the strap with the tapestry needle.

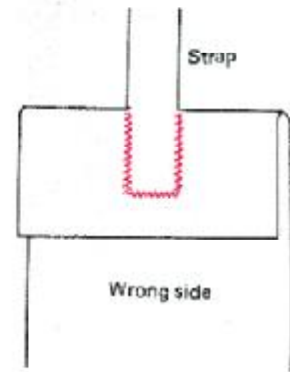

B) With the sewing machine

Attach the strap to the front side of the swatch and sew the edge of it with the sewing machine from behind.

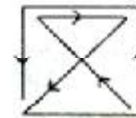
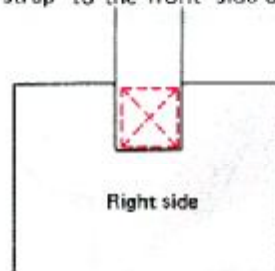

C) Attaching the cord to the reversible swatch

① Thread the yarn into the edge of the swatch as shown in the diagram.

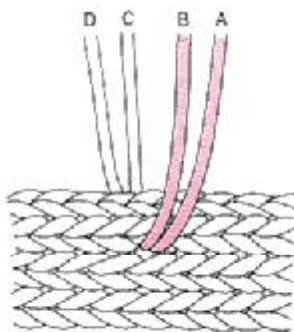

② Cross the end of yarn (A and B) as shown in the diagram.

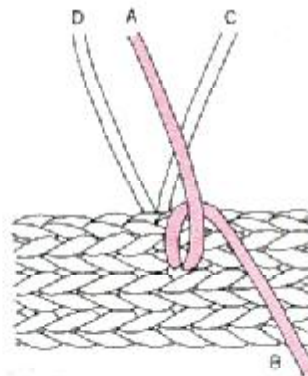

③ Cross the end of yarn (C and D) as shown in the diagram.

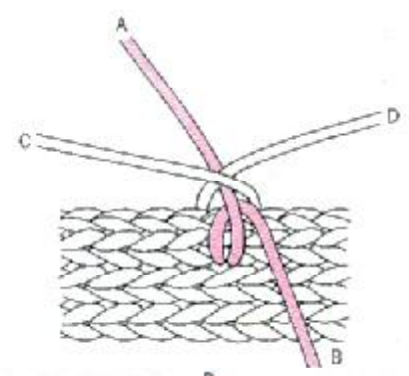

④ Cross the end of yarn (A and B) and bring the end of A yarn toward you as shown in the diagram.

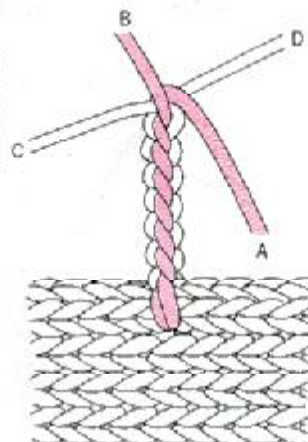

⑤ Cross the end of yarn (C and D) and bring the end of D yarn toward you as shown in the diagram. Repeat these steps ②-⑤, the cord is completed.

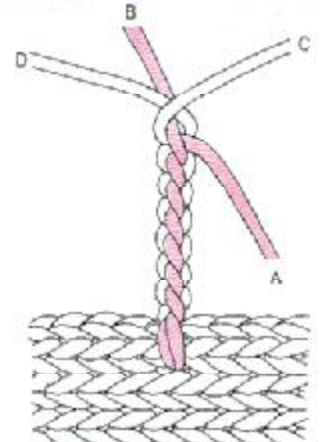

Attaching the lining to a skirt

A) How to knit a waist belt and allowance for the lining

① Decrease the stitches according to the size of the waist belt at the waist line. (In case of a pleated skirt, pick up the stitches and hook them onto the machine.)

② Knit one row with the tension two numbers higher, than the main tension. Knit one half of the waist belt with the main tension and the other half with the tension one number lower than main tension.

③ Pick up the stitches which are knitted with the higher tension at the waist line and hook them onto the hooks of the needles.

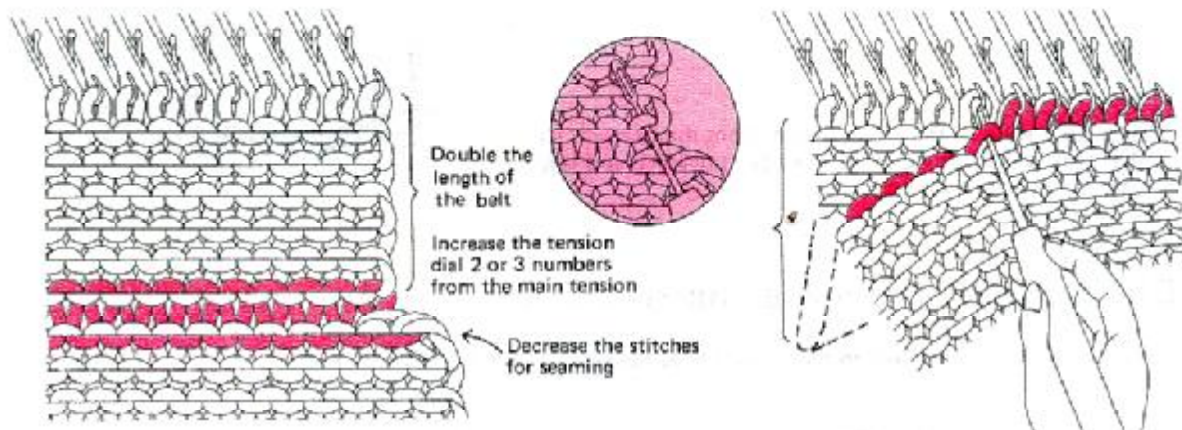

④ Set the tension dial at the main tension and knit several rows for the allowance for the lining, then place the K carriage on the left side of the machine.

Cut the yarn leaving a length three times the width of the knitting

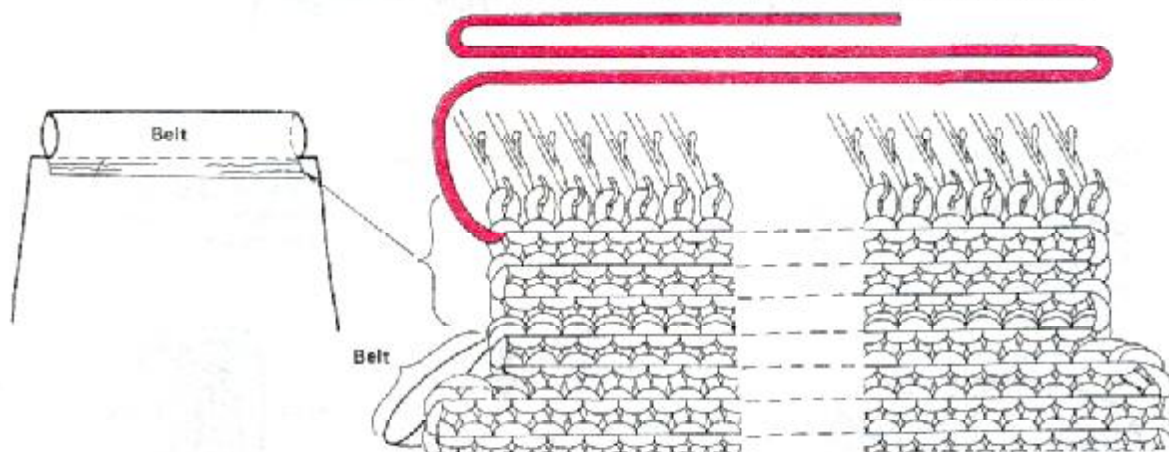

⑤ Bind all the stitches off with the tapestry needle.

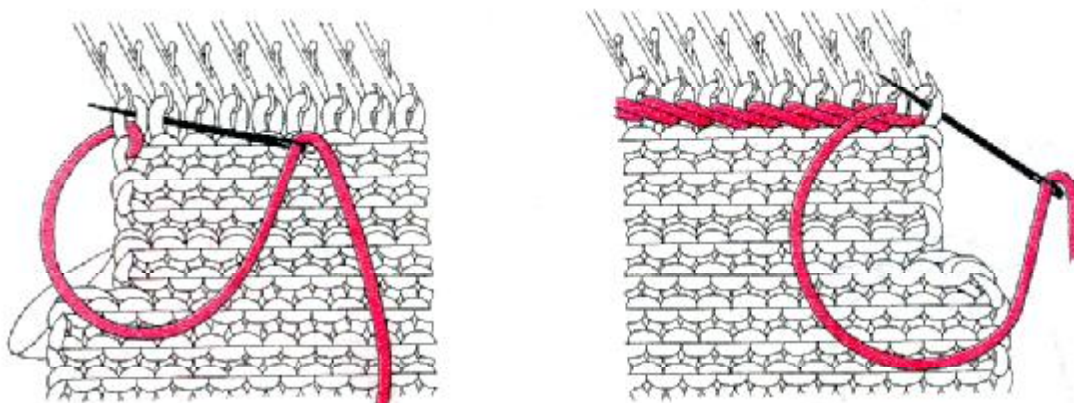

- ① Draw the pattern of the skirt without the waist belt and folded part, and cut out the lining according to the pattern as shown in the diagram.

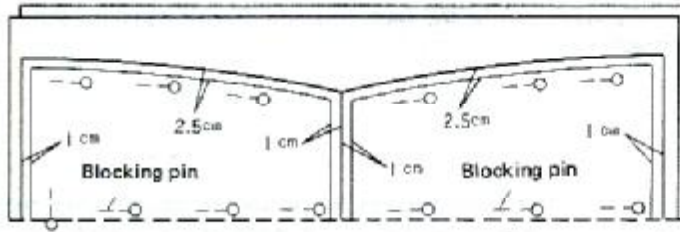

- ② Sew both sides of the lining, 20 cm from the bottom. At the hem of the lining, fold the hem up twice and sew with the sewing machine.

C) Attaching the lining to the skirt

- ① Fold part of the waist belt to the front side of the skirt as shown in the diagram.

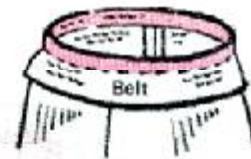

- ② Place the lining inside out and put the skirt into the lining. (Put the lining and skirt inside out.) Pin the edge of lining and the allowance with the blocking pin, then baste them with the tapestry needle.

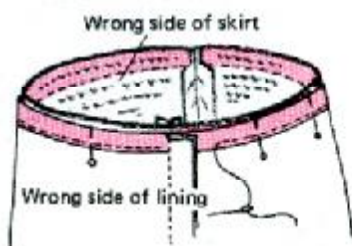

- ③ Sew them with the sewing machine.

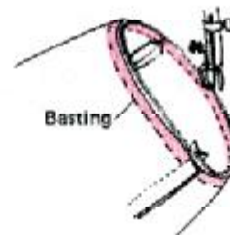

- ④ Attach the side of the lining to the wrong side of the skirt with the tapestry needle. This time, sew them with large stitches.

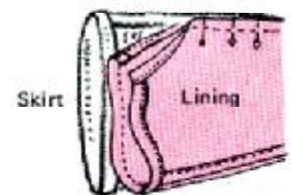

- ⑤ Insert the belt and put both ends together, then sew the overlapping point.



- ⑥ Sew part of the belt with the tapestry needle.



Sticking cloth (viene) or sticking tape

Stick the sticking cloth and/or tape on the basted part of the swatches and steam lightly with the steam iron.

A) Finish the jacket with sticking cloth and/or tape

① Stick the sticking tape on the allowance part as shown in the diagram.

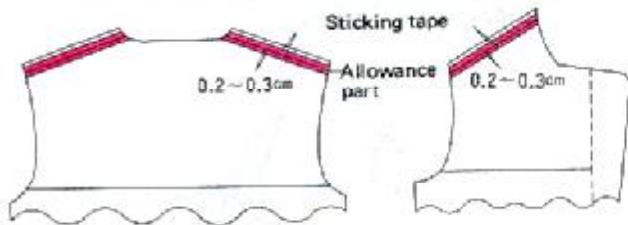

③ Sew both sides in the same manner as item ②

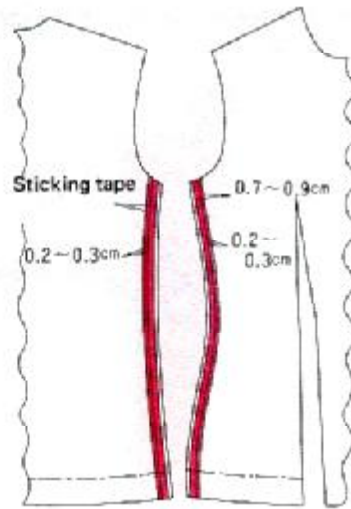

② Avoid stretching the stitches at the shoulder, stick the sticking tape on the allowance of the back shoulder line and sew them together with the sewing machine.

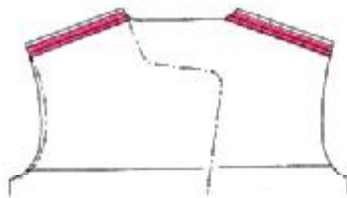

④ Stick the sticking tape on the folded part of the jacket as shown in the diagram. (Cut about 3 cm off both ends off the folded part as shown in the diagram.)

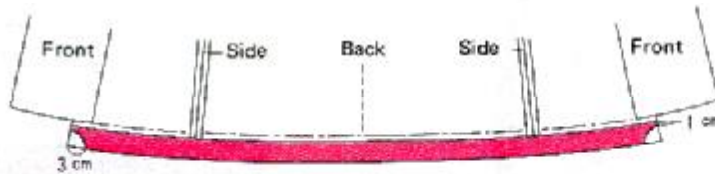

⑤ Do the same operation as above for the sleeves as shown in the diagram.

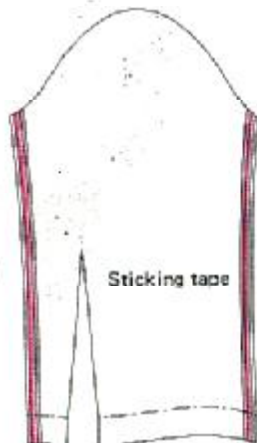

⑥ Stick the sticking cloth on the folding part of the cuff as shown in the diagram.

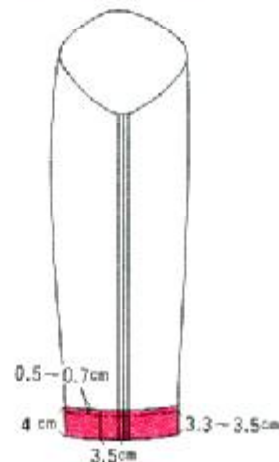

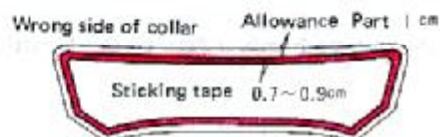
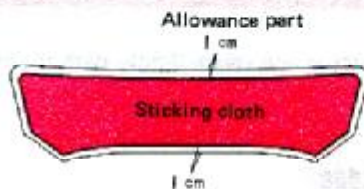

① Stick the sticking cloth on the wrong side of the inter facing.

② After sticking, it is better to sew the edge of collar and border with the sewing machine as shown in the diagram.

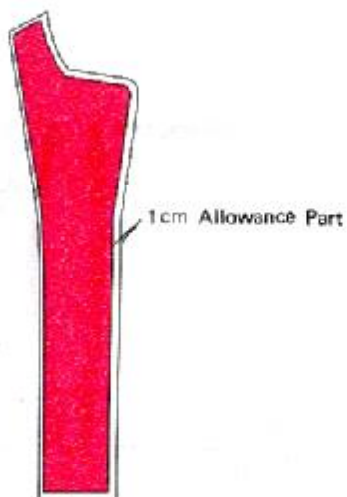

B) Skirt

① Stick the sticking tape on both sides of the skirt as shown in the diagram.

② Stick the sticking cloth on the folded part of the hem as shown in the diagram.

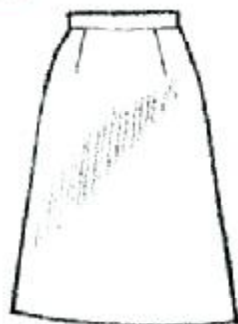
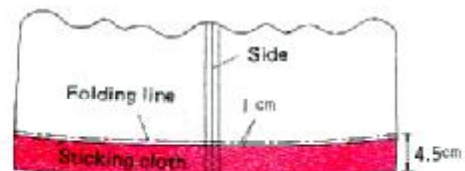
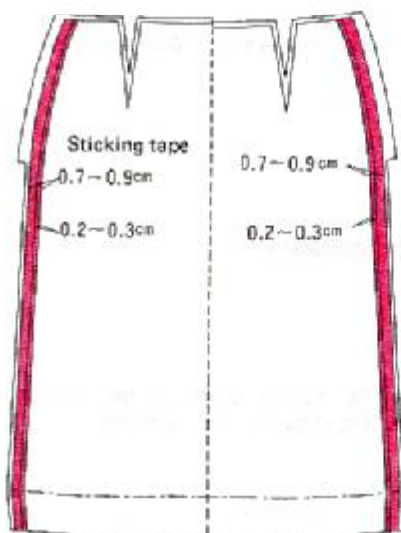

20 Pompon / Tassel

Pompon (1)

A) With chain stitch

① Make a loop and knit one chain stitch with the crochet hook as shown in the diagram.

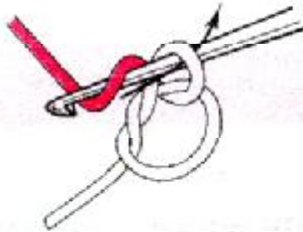

② On the first row, knit six chain stitches and pull the end of the yarn to close the loop as shown in the diagram.

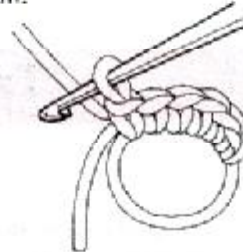

③ On the second row, knit two chain stitches on the stitch of the first row of chain stitches. Repeat this to increase the stitches up to half the depth of the pompon as shown in the diagram. Then, decrease the stitches and knit the other half of the pompon as shown in the diagram.

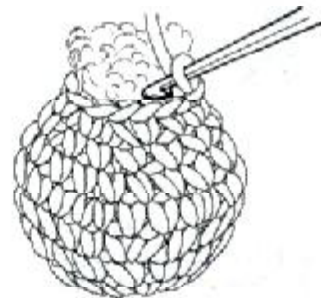

B) With crochet stitch

Do the same operation as in item A). Make the crochet stitches at the cast-on edge and cast-off edge with the crochet hook.

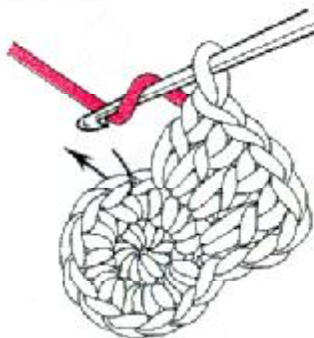

Pompon (2)

① Loop the yarn around card-board according to the size of the pompon as shown in the diagram.

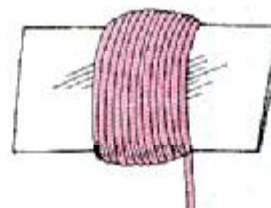

tie the centre of them with the yarn as shown in the diagram.

shown in the diagram.

scissors as shown in the diagram.

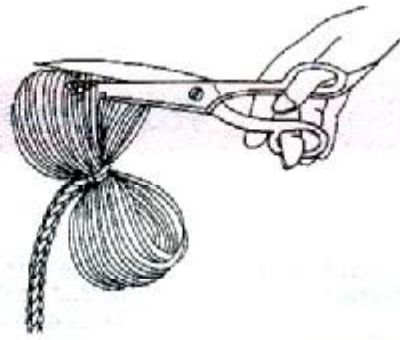

Tassel

A) Fringe

① Insert the yarn into the edge of the swatch as shown in the diagram. Pass the ends of the yarn through the loop to make a fringe as shown in the diagram.

② Tie each end of the fringe to make a different type of fringe as shown in the diagram.

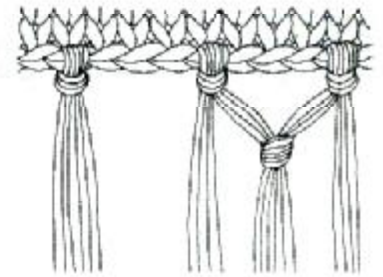
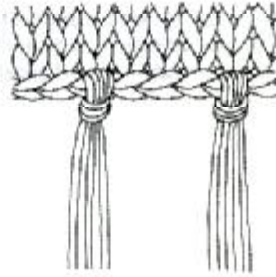

B) Tassel

① Loop the yarn around the card-board according to the size of the tassel as shown in the diagram.

② Take the card-board out and tie the centre of them with the yarn as shown in the diagram. Then, cut both ends of them.

③ Attach the cord to the centre of them firmly.

④ Put the cord at the centre and fold the yarn. Then, tie the top of tassel as shown in the diagram.

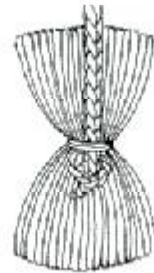
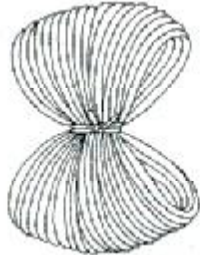
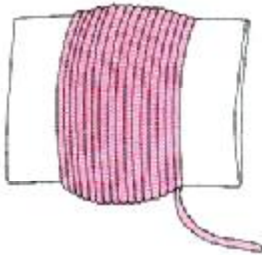

C) With a crochet hook

Knit the tassel according to the symbols as shown in the diagram with the crochet hook.

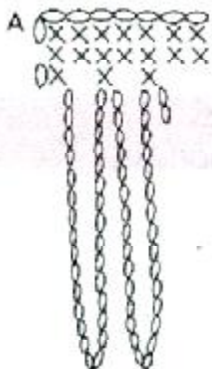

Basic stitch

Satin stitch

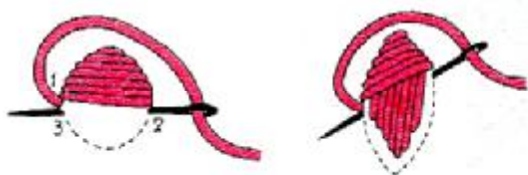

Chain stitch

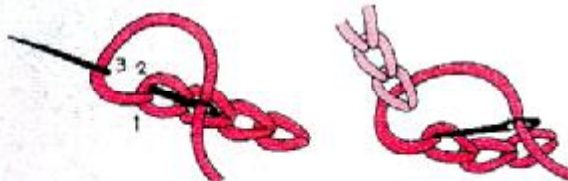

Outline stitch



Swiss darning

A) Method (1)

① Insert the tapestry needle into the stitch from the back. Pass the tapestry needle through the stitch from the front as shown in the diagram.

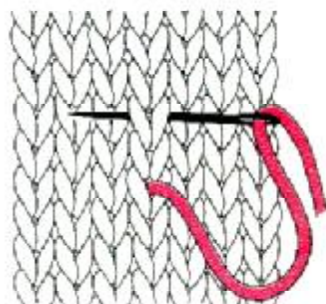

② Back to the first stitch, pass the tapestry needle through the stitch from the right side as shown in the diagram.

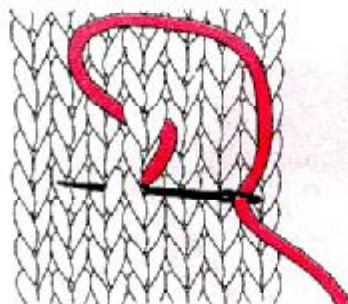

③ Repeat these steps.

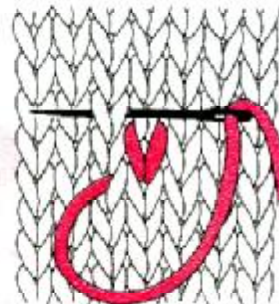

B) Method (2)

① Insert the tapestry needle into the stitch from the back and pass it through the stitch from the front as shown in the diagram.

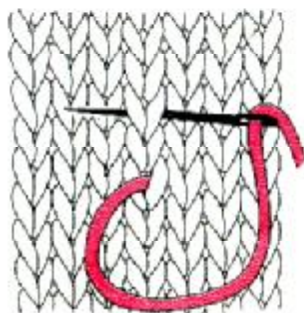

② Back to the first stitch, pass the tapestry needle under the lower stitch needle loop as shown in the diagram.

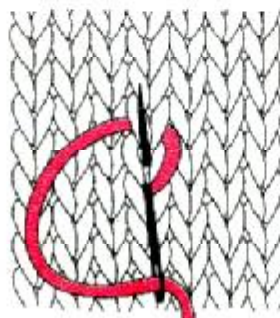

③ Repeat these steps.

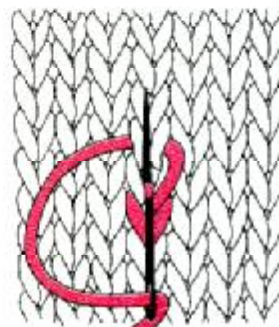

At the point of the embroidery, make rib stitches with the latch tool or make an open stitch pattern. Then, make a chain stitch with the crochet hook (Pass the embroidery yarn through the stitch from the back.)

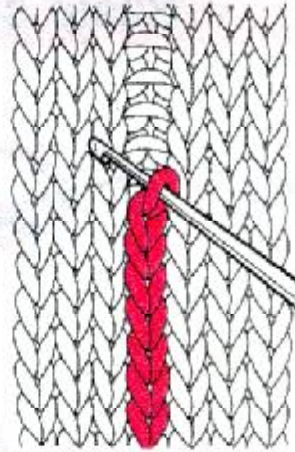

ADVANCED TECHNIQUES

1 Picture Knitting



Picture knitting means making a picture on the swatch by threading the contrast colour yarn behind the stitches on the swatch.

How to knit picture knitting

A) How to hook the contrast colour yarn

- ① Prepare the same number of contrast yarns as on the picture.
- ② To make an effective pattern, it is better to use thicker yarns than the main yarn.
- ③ You will require five times the length of the lines shown in the picture.

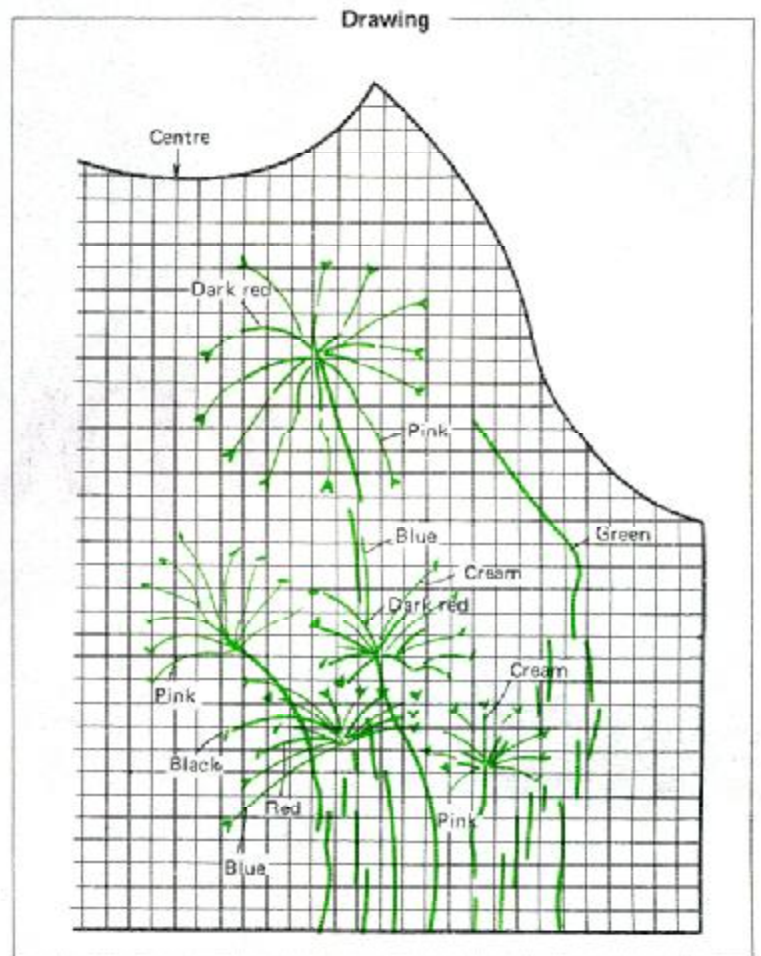

B) Using the wrong side as the front

- ① Take the stitch off the needle with the transfer tool and thread the contrast colour yarn behind the stitch as shown in the diagram.

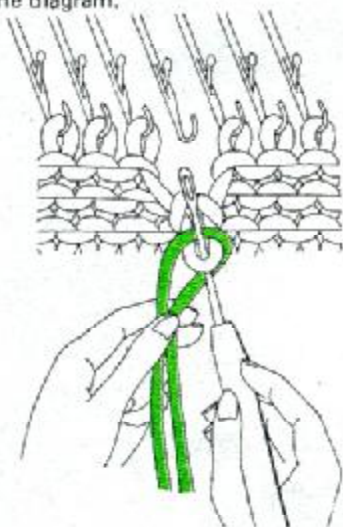

- ② Put the stitch back onto the needle and knit one row with the main yarn. Insert the tapestry needle with the contrast colour yarn into the left sinker loop and pull through as shown in the diagram.

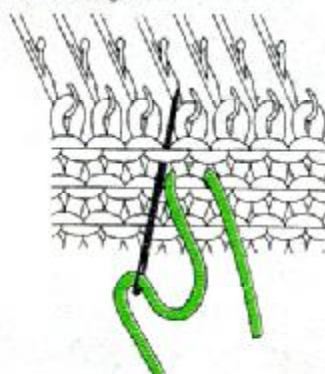

- ③ Knit one row and insert the tapestry needle into the right sinker loop and pull through as shown in the diagram.

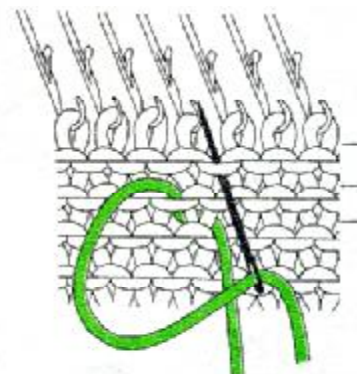

④ Knit one row and insert the tapestry needle into the left sinker loop and pull through as shown in the diagram.

⑤ Repeat these steps according to the picture line.

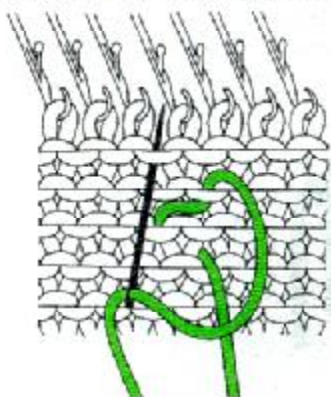

C) Using the front side as the front

Knitting symbol

	1	2	3	4	5	6	7	8	9	10	11	12
8	-	-	-	-	-	-	-	-	-	-	-	-
7	-	-	-	-	-	-	-	-	-	-	-	-
6	-	-	-	-	-	-	-	-	-	-	-	-
5	-	-	-	-	-	-	-	-	-	-	-	-
4	-	-	-	-	-	-	-	-	-	-	-	-
3	-	-	-	-	-	-	-	-	-	-	-	-
2	-	-	-	-	-	-	-	-	-	-	-	-
1	-	-	-	-	-	-	-	-	-	-	-	-



(1) With the transfer tool.

① Take the stitch off the needle with the transfer tool and thread the contrast colour yarn behind the stitch according to the picture line, as shown in the diagram. Put the stitch back into the hook of the needle.

② Knit one row and take the stitch off the needle with the transfer tool, then thread the contrast yarn behind the stitch as shown in the diagram. Put the stitch back into the hook of the needle.

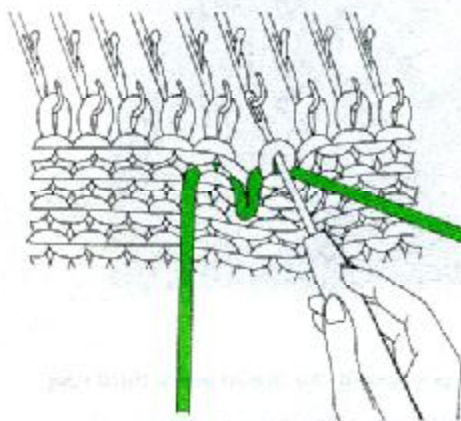
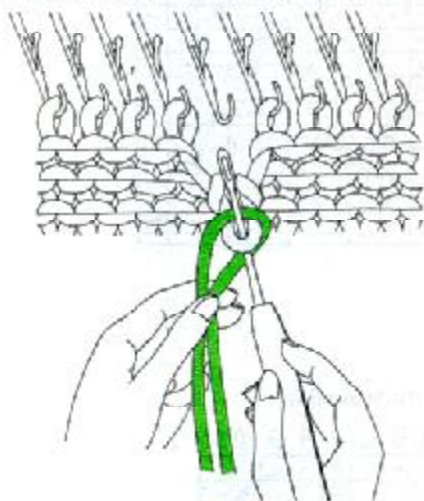

(2) With the tapestry needle.

According to the picture line, thread the tapestry needle with the contrast colour yarn behind the stitches as shown in the diagram.

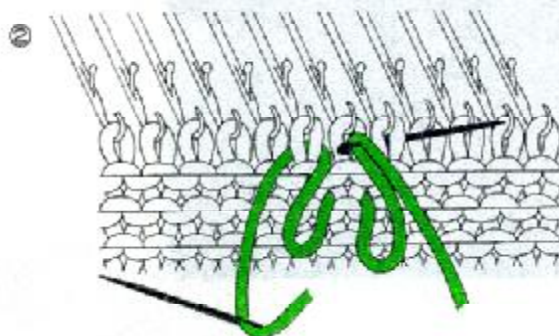
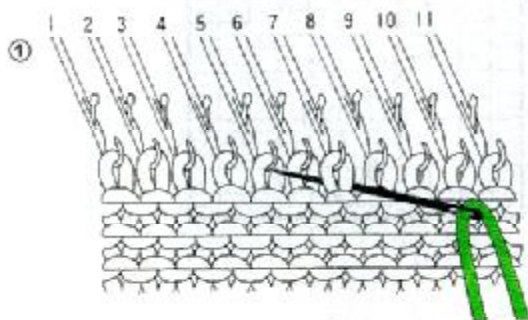

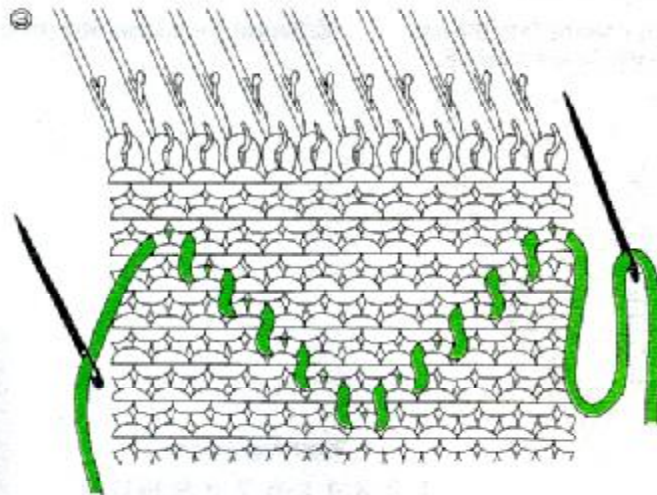

Application

Thread the contrast colour yarn twice or three times at the same position, it is possible to make different designs.

Changing the position of the thread on every other row.



Knitting symbol

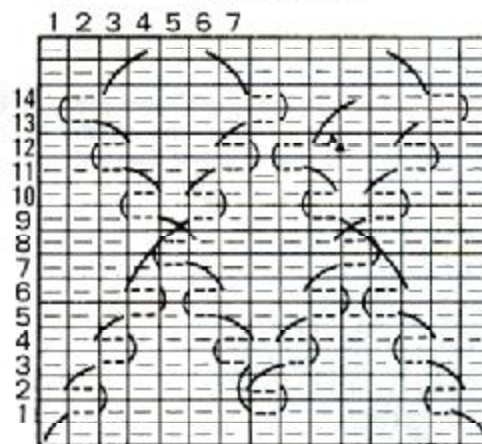

Changing the position of the thread every third row.



Knitting symbol

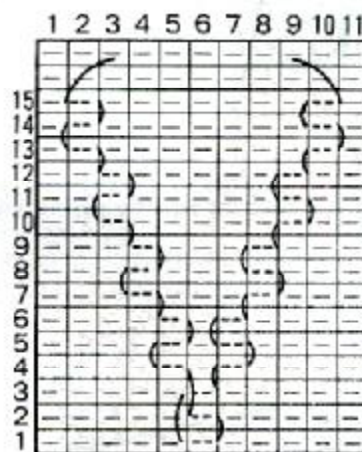

2 Volume Knitting



How to knit volume knitting



Materials: Main Yarn Fine Yarn
 Threading Yarn Very Thick Yarn
Swatch: Plain Knitting
 (thread the thick yarn into the swatch)
Machine: Bulky machine

A) How to thread the yarn

- ⤴ Pick up half of the thick yarn (threading yarn) with the transfer tool and hook it onto the hook of the needle as shown in the diagram.
- ⊖ Pick up the thick yarn (threading yarn) with the transfer tool and hook it onto the hook of the needle as shown in the diagram.

Knitting Symbol

	⊖	⊖	⊖	⊖	⊖	⊖	⊖	⊖	⊖	⊖	⊖	⊖	⊖	⊖	⊖	⊖	⊖	⊖	⊖
	⊖	⊖	⊖	⊖	⊖	⊖	⊖	⊖	⊖	⊖	⊖	⊖	⊖	⊖	⊖	⊖	⊖	⊖	⊖
4	⊖	⊖	⊖	⊖	⊖	⊖	⊖	⊖	⊖	⊖	⊖	⊖	⊖	⊖	⊖	⊖	⊖	⊖	⊖
3	⊖	⊖	⊖	⊖	⊖	⊖	⊖	⊖	⊖	⊖	⊖	⊖	⊖	⊖	⊖	⊖	⊖	⊖	⊖
2	⊖	⊖	⊖	⊖	⊖	⊖	⊖	⊖	⊖	⊖	⊖	⊖	⊖	⊖	⊖	⊖	⊖	⊖	⊖
1	⊖	⊖	⊖	⊖	⊖	⊖	⊖	⊖	⊖	⊖	⊖	⊖	⊖	⊖	⊖	⊖	⊖	⊖	⊖
	1	2	3	4															

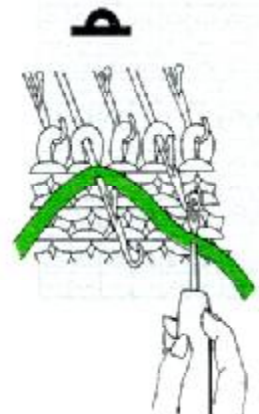

① On the first row, pick up half of the threading yarn and hook it onto the first needle as shown in the diagram. Miss one stitch and hook the threading yarn onto the third needle as shown in the diagram. Repeat these steps (according to the symbol marks) to the end of the swatch.

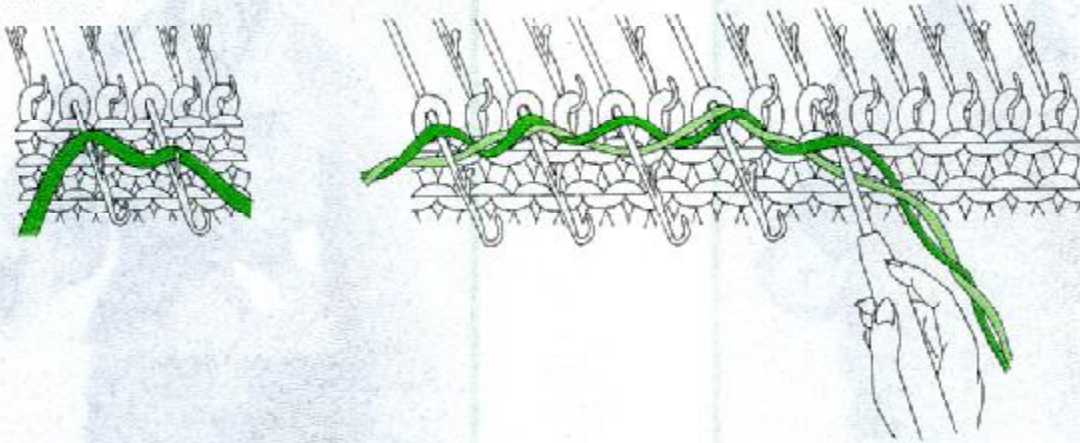

② Knit one row or two according to the chart and thread the yarn the opposite way as shown in the diagram, according to the symbols.

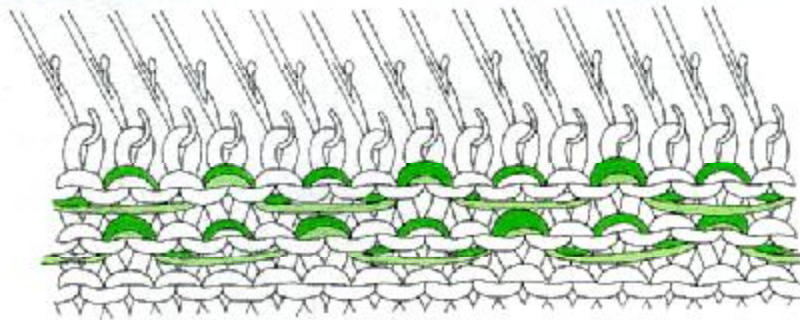

Application

Combining these two kinds of threads you can make a variety of patterns.

(Thread the yarn every other row) (Thread the yarn every third row)

Knitting symbol

	△	△	△	△	△	△	△
	△	△	△	△	△	△	△
	△	△	△	△	△	△	△
	△	△	△	△	△	△	△
	△	△	△	△	△	△	△
2	△	△	△	△	△	△	△
1	△	△	△	△	△	△	△
	1	2					

Knitting symbol

	△	△	△	△	△	△	△
	△	△	△	△	△	△	△
	△	△	△	△	△	△	△
	△	△	△	△	△	△	△
	△	△	△	△	△	△	△
3	△	△	△	△	△	△	△
2	△	△	△	△	△	△	△
1	△	△	△	△	△	△	△
	1	2					

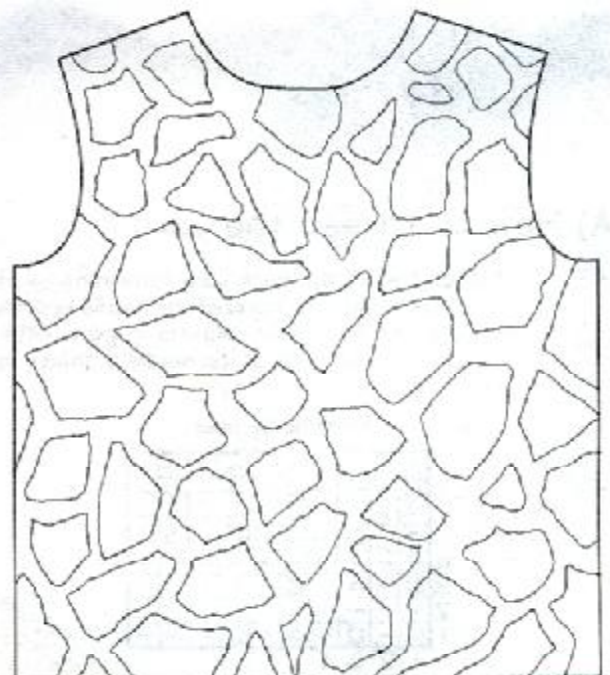

3 Copy Knitting



Drawing

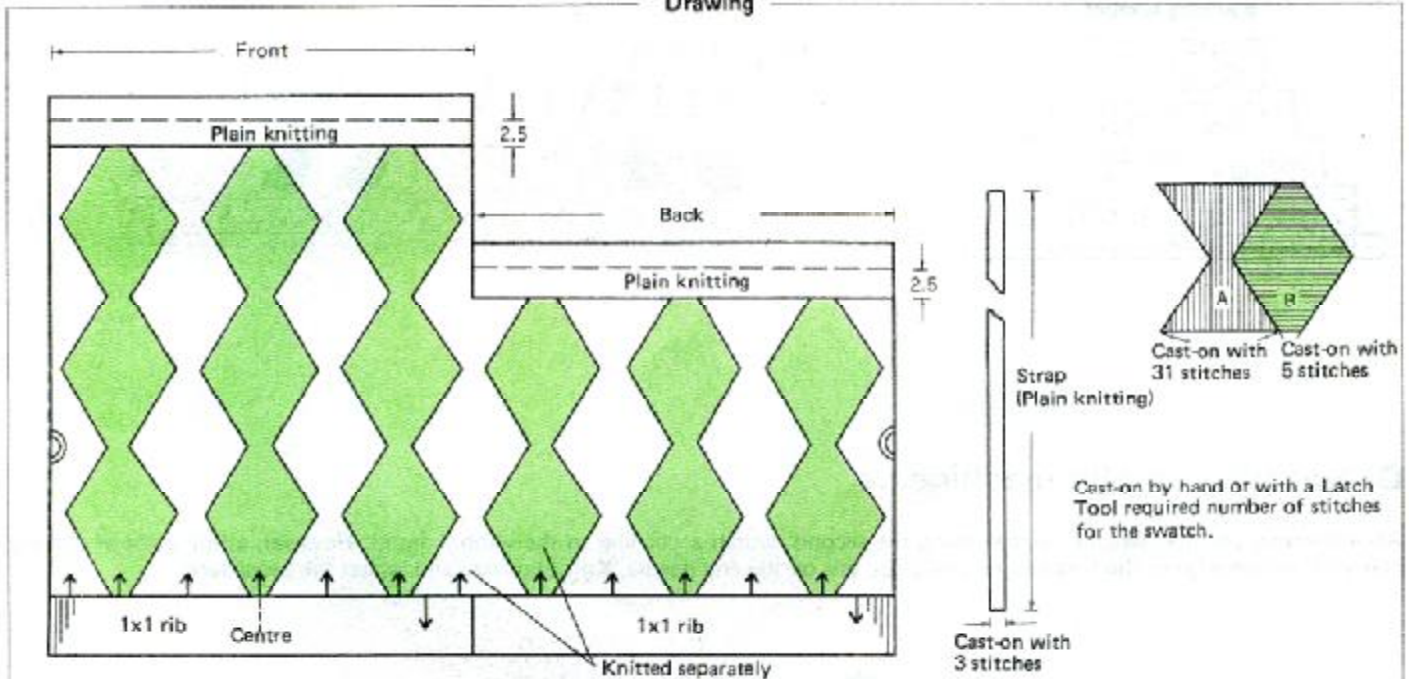

How to knit and seam

A) How to make a lace effect by hand every two rows on the edge of a swatch

Knit two rows and transfer every second stitch from the edge onto the third needle on both edges, using the transfer tool. Knit two rows. Repeat this according to the symbol marks.

Knitting symbol

—	—	—	—	—	—	—	—	—	—	—	—
—	○	△	—	—	—	△	○	—	—	—	—
—	○	△	—	—	—	△	○	—	—	—	—
—	○	△	—	—	—	△	○	—	—	—	—
—	○	△	—	—	—	△	○	—	—	—	—
—	○	△	—	—	—	△	○	—	—	—	—

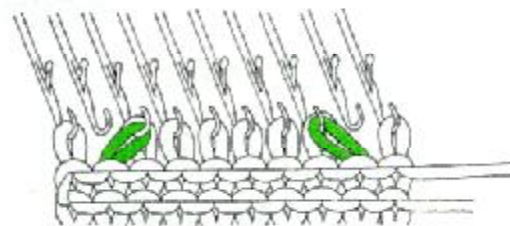

B) How to make a lace effect by increasing by hand every two rows

Knit two rows and transfer the edge stitches to the adjacent empty needle. Knit two rows and repeat according to the symbol mark

Knitting symbol

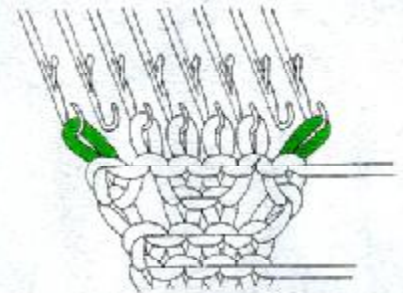
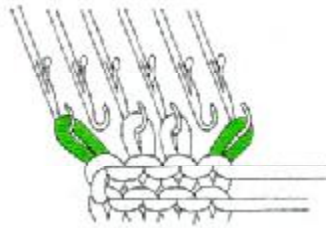
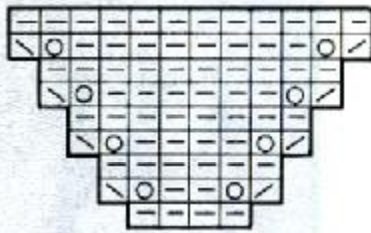

C) How to make a lace effect by decreasing by hand every two rows

Knit two rows and transfer the third stitch from the edge to the fourth needle on both sides of the swatch. Then transfer the 2 stitches to the adjacent inside needles. Therefore, you have decreased a stitch on either side. Repeat this procedure according to symbol marks.

Knitting symbol

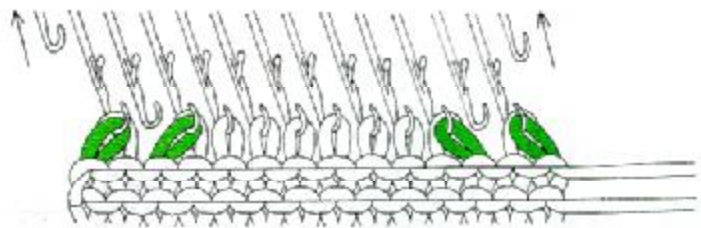
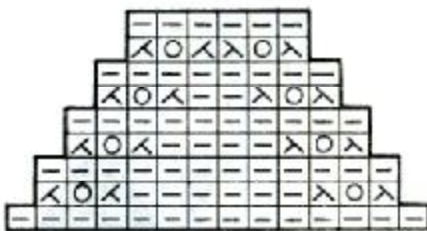

D) Seaming on the machine

After knitting the first swatch, start knitting the second swatch according to the symbol marks. However, at the point of making hole pick up the edge of the first swatch and place this on the end needle. Knit two rows and repeat the procedure.

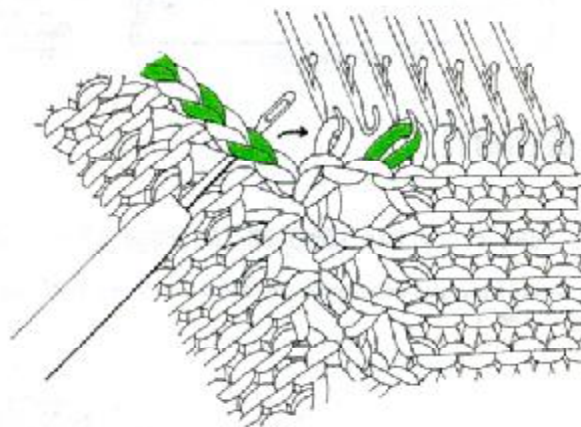

Application

A) Combining method A, B & C (swatches), it is possible to produce various designs

Example: on a ladies top or cushion using the square or triangular methods.

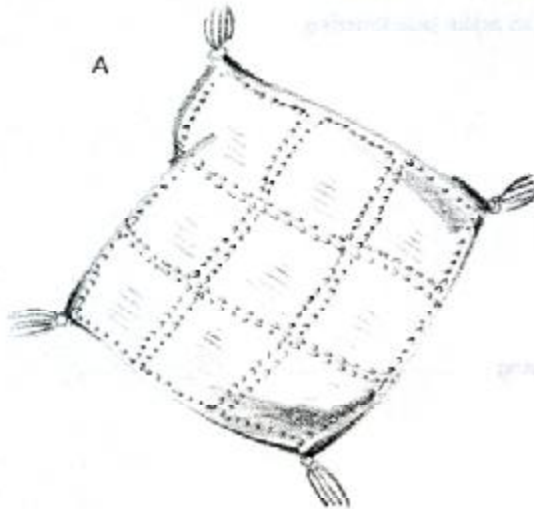

B) Braiding

Knitting symbol

	-	-	-	-	-	-	-	-	-	-
	○	/	/	△	△	\	\	○		
	○	/	/	△	△	\	\	○		
	○	/	/	△	△	\	\	○		
2	○	/	/	△	△	\	\	○		
1	-	-	-	-	-	-	-	-	-	-
	1	2	3	4	5	6	7	8	9	10



① Knit braids according to the symbol marks. After the braid is complete, pick up the edge of the braid and place the stitches onto the needles, then continue knitting the garment.

② Knit the garment, then attach the braid using the blind stitch method.

③ Attach the braid using seaming or machine method. (D page 112)

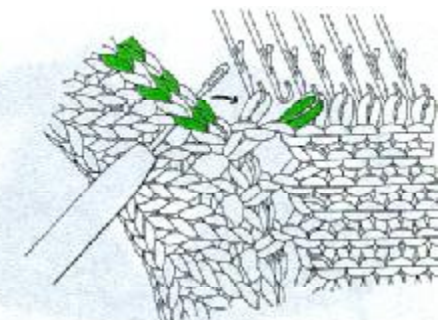
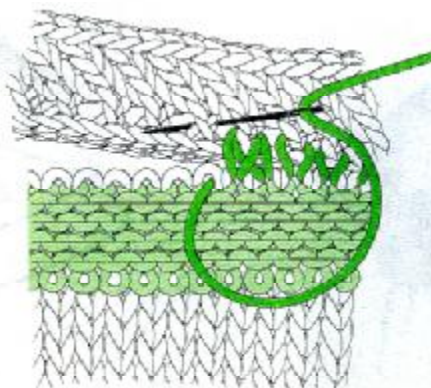
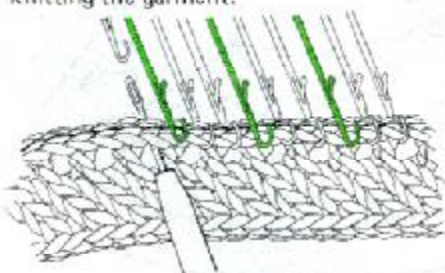

4 Motif Knitting



Make a triangular swatch by increasing the stitches on the K carriage side and decreasing the stitches using partial knitting. Seam them together using partial knitting.

- 1 Easy to make a round yoke.
- 2 Make intarsia effect on swatch.
- 3 Easy to make bias knitting.

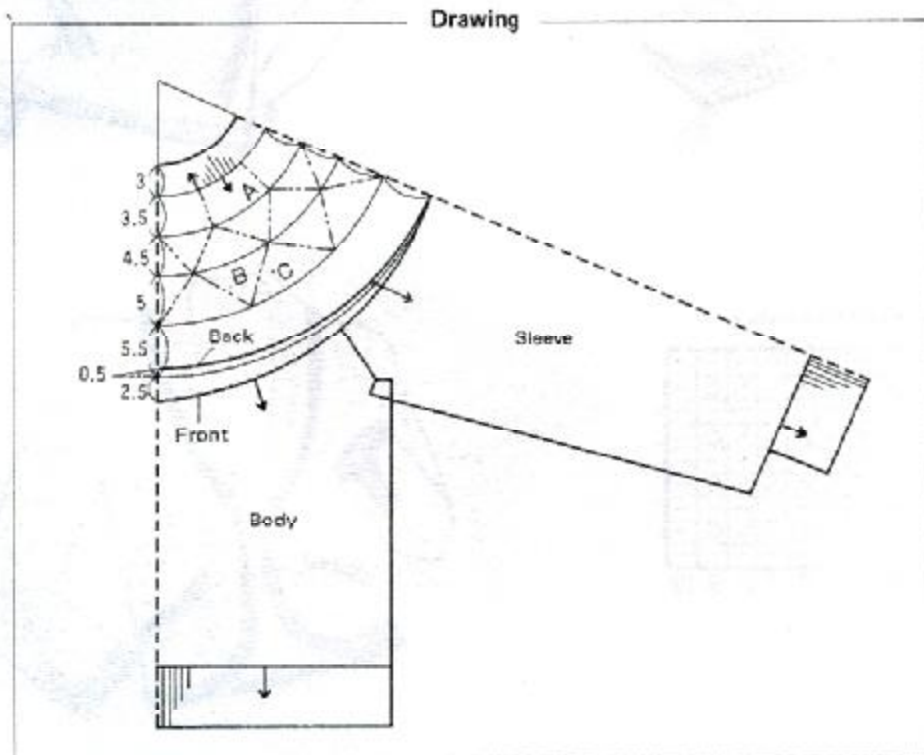

How to knit Motif knitting

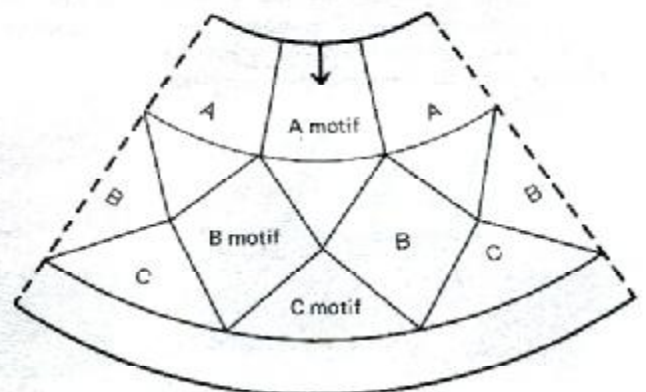

A) How to knit motif knitting (First A-motif)

- ① Bring forward the required number of needles for the motif to position 'E' according to the symbol marks. Then cast-on by hand using the 'e' wrap method using waste yarn. Knit two rows from the right side with waste yarn, then take the waste yarn out of the yarn feeder. Leave the waste yarn end.
 - ② Press both 'PART' buttons and pass the K carriage to the left side of the knitting machine, then thread the cast-on thread into the yarn feeder. Cancel both 'PART' buttons and knit one row to the right. Leave the cast-on thread end.
- ※ Waste yarn end and cast-on thread end will be used for the cast-on of the second A-motif.

Knitting symbol for A-motif

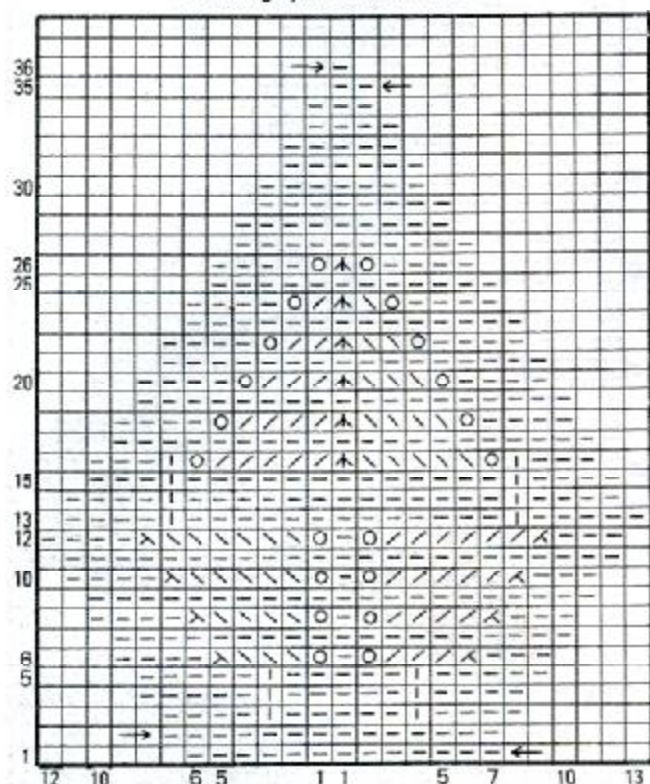

- ③ Thread the main yarn into the yarn feeder and knit one row to the left. Bring forward one empty needle to position 'B' at the left edge and knit one row to the right. Put a yarn mark onto the increased stitch as shown in the diagram.

How to make reference mark

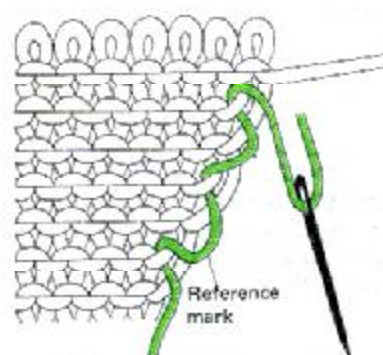

- ④ Bring forward one empty needle to position 'B' at the right edge and knit one row to the left. Put a yarn mark onto the increased stitch as shown in the diagram. Repeat these steps ③-④ making the pattern according to the symbol marks until you reach the right thirteenth and the left twelfth needles.
- ⑤ On the thirteenth row set the H.C.L. to H (Push button machine to II) and bring forward one needle to position 'E' from the end, at the opposite side of the K carriage. On the K carriage side pass the yarn under the 'E' position needle before operating the K carriage to the other side. Repeat these steps making the pattern according to the symbol marks to the top of the pattern.
- ⑥ Re-thread the waste yarn and take the switch off on waste knitting.

(Second A-motif)

- ① Using the first motif waste yarn end and cast-on thread end make an 'e' wrap cast-on. Knit two rows from the right with waste yarn and one row from the left with the cast-on thread.
- ② On the left side of the second motif, bring forward six needle to position 'E' and pick up the increased stitches of the first motif and place them onto the needles. There is no need to pick up the last increased stitch.

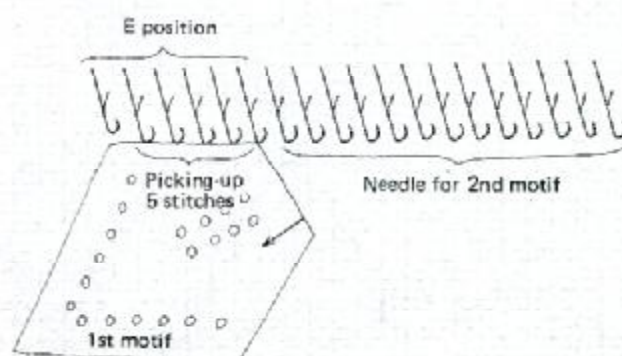
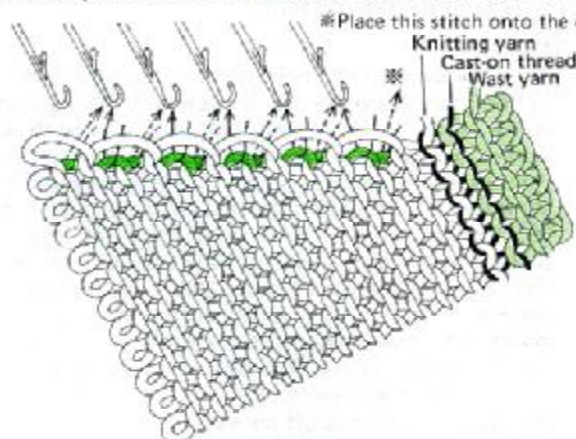

- ③ Set the H.C.L. to H (Push button machine to II) and knit one row with the main yarn, pass the yarn under the right end 'E' position needle and knit one row to the right.
- ④ Bring forward one empty needle to position 'B' at the right edge and push back the right end 'E' position needle to position 'D' and knit one row to the left. Put a yarn mark on the increased stitch in the same manner as the first motif.
- ⑤ Pass the yarn under the right end 'E' position needle and knit one row to the right.
Repeat these steps ④-⑤ and knit the second motif according to the symbol marks. In the same manner as the first motif.

(Third A-motif)

Make the third motif in the same manner as the second motif.

(First B-motif)

- ① Bring forward all the needles from the left 12th to the right 13th to position 'B'. Pick up the right edge stitch of the first A-motif and the left edge of the second A-motif and place them onto the centre needle according to the symbol mark of the B-motif. Pick up all the stitches of the first and second A-motif according to the symbol marks and place them onto the 'B' position needles.
- ② Bring all the needles except the centre needles to position 'E' and set the H.C.L. to H (Push button machine to II). Knit two rows and place the carriage at the right side.
✳ Push back the left adjacent 'E' position needle from the centre needle to position 'D'. And pass the yarn under the right adjacent 'E' position needle from the centre needle. Knit one row to the left, pass the yarn under the first 'E' position needle on the left side of the centre needle, and push back the right adjacent needle from the centre needle to position 'D'. Then knit one row to the right. Repeat these steps upto the 24th row of the B-motif.
- ③ From the 25th row decrease the stitches according to the symbol marks using partial knitting. After knitting the first B-motif, take the stitches off on waste yarn.

Knitting symbol for C-motif

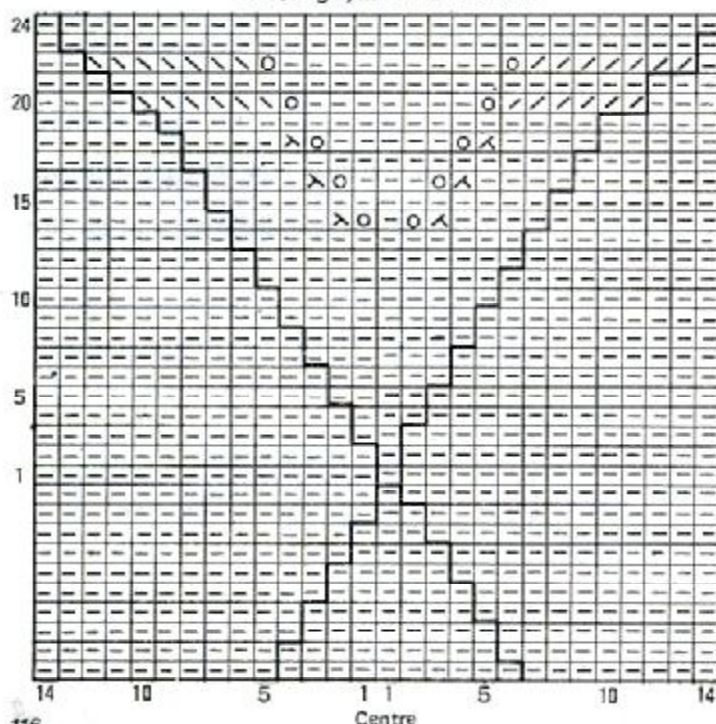

Knitting symbol for B-motif

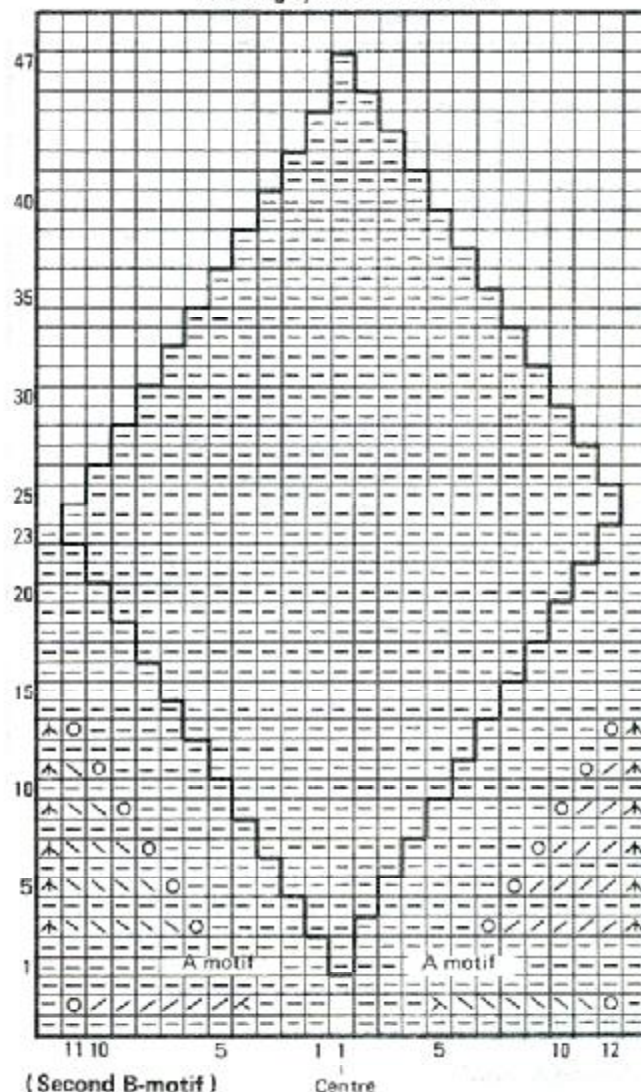

(Second B-motif)

Pick up the right edge stitch of the second A-motif and the left edge stitch of the third A-motif and place them onto the centre needle according to the symbol marks on the B-motif. Knit the second B-motif in the same manner as the first B-motif.

(First C-motif)

Bring forward all the needles from the left 12th needle to the right 12th needle to position 'B'. Pick up the centre stitch of the A-motif and place it onto the centre needle according to the symbol mark on the C-motif. Pick up all the stitches of the first and second B-motifs according to the symbol marks and place them onto the 'B' position needles. Knit upto the 20th row of the C-motif in the same manner as the B-motif (refer to item First B-motif ② and ③). On the 20th row, transfer all the stitches to the outside needle according to the symbol marks. Knit two rows and transfer all the stitches to the outside needle on the 22nd row according to the symbol marks. Then continue to the end of the C-motif and then take the stitches off on waste yarn.

5 Knitting Motifs without Seams



A) Using partial knitting

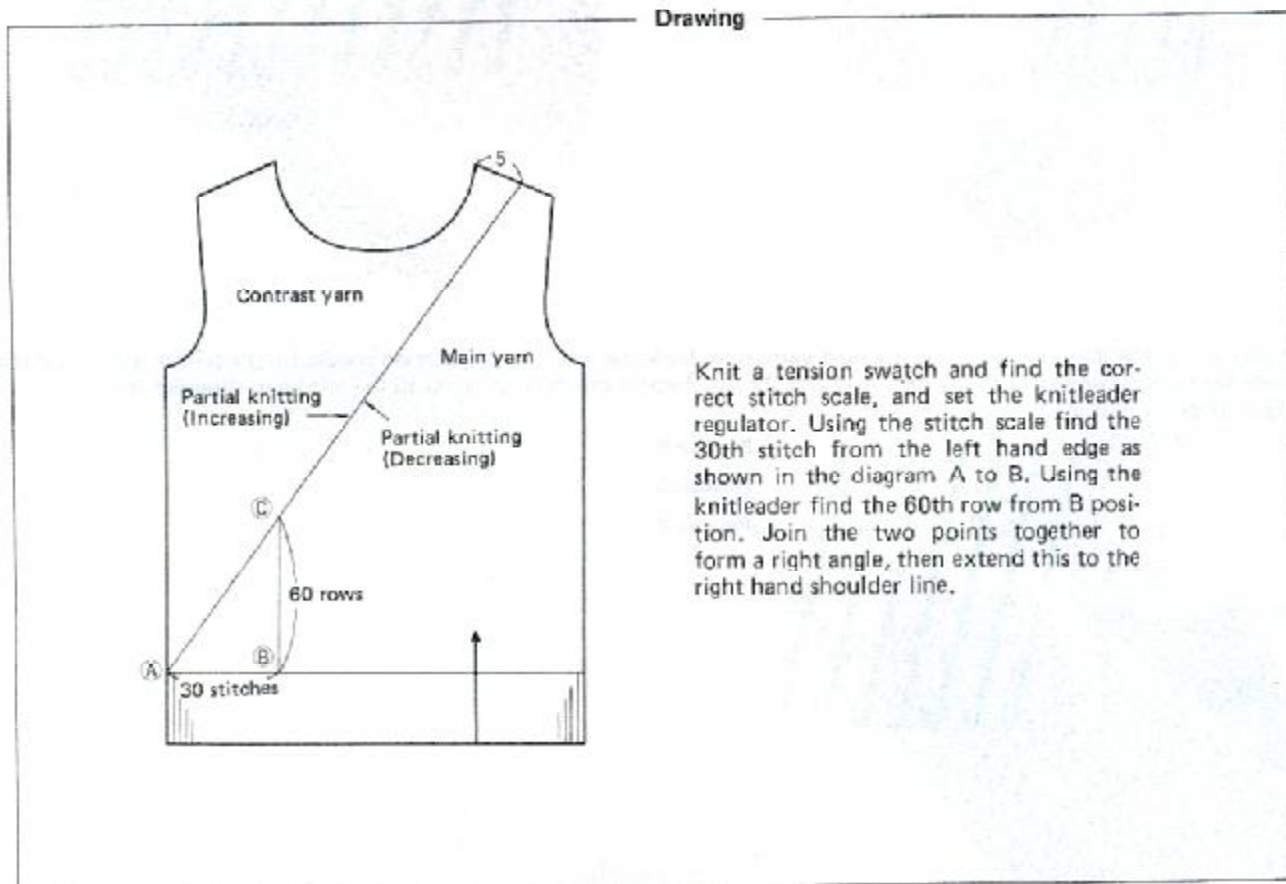

Knit a tension swatch and find the correct stitch scale, and set the knitleader regulator. Using the stitch scale find the 30th stitch from the left hand edge as shown in the diagram A to B. Using the knitleader find the 60th row from B position. Join the two points together to form a right angle, then extend this to the right hand shoulder line.

How to make knitting Motifs without seams

- ① Knit one row with the main yarn from left to right and place the carriage at the right, bring forward the left edge needle to position 'E'.

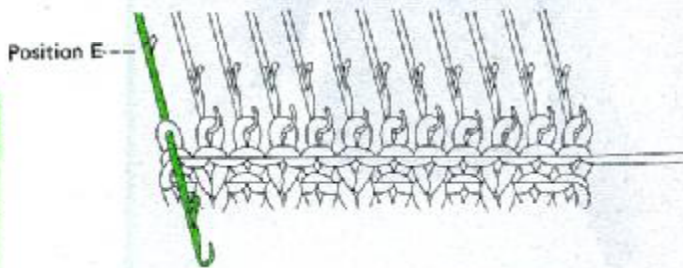

- ② Set H.C.L. to H (Push button machine to II) and knit 2 rows, then bring needles forward to position 'E' according to the pattern. (Decrease the stitches for partial knitting)

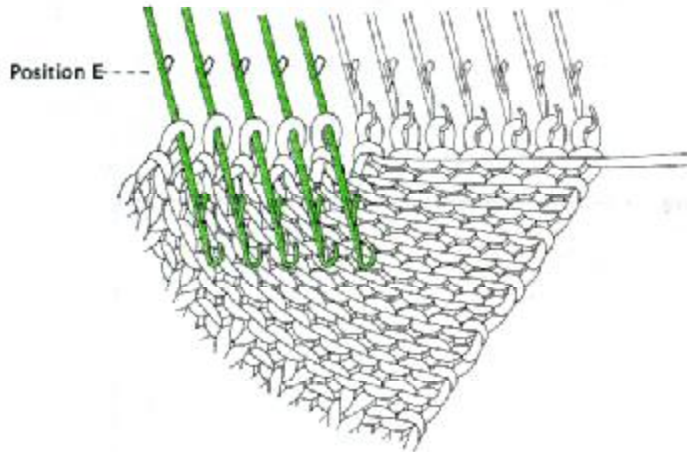

- ③ Repeat this procedure up to the shoulder line, then bring all the needles to position 'E'.

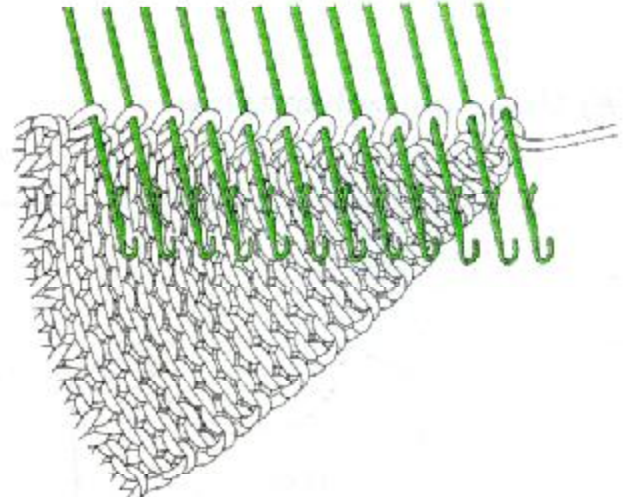

- ④ Place the carriage at the left, change to the contrast yarn, push back the left edge 'E' position needle to 'D' position and knit 2 rows, push the needles back according to the pattern and knit 2 rows. Repeat this procedure up to the left hand shoulder line. (Increasing stitches for partial knitting)

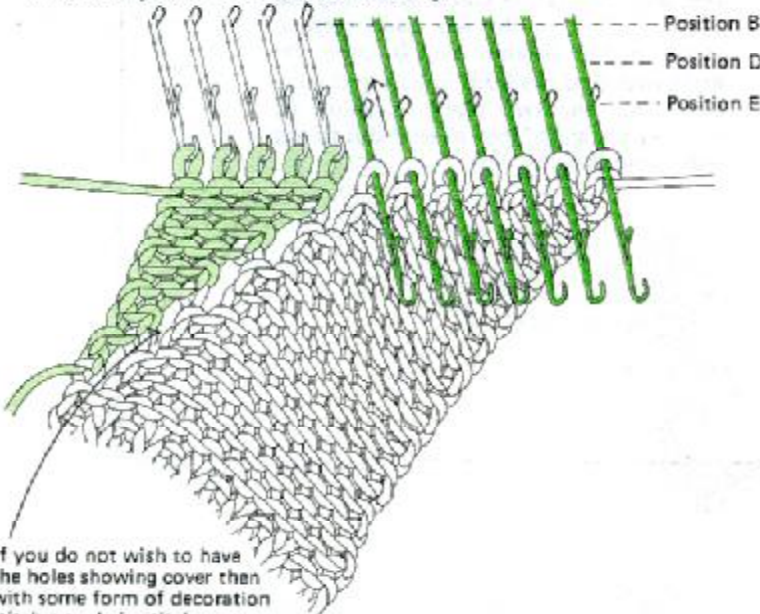

If you do not wish to have the holes showing cover them with some form of decoration stitch e.g. chain stitch.

B) Using the cast-on thread

- Multi colour motif knitting.
- Combining multi colour patterns.
- Combining Horizontal and vertical stripes.
- Apply when knitting a yoke.
- 48 stitches pattern with a punch card.

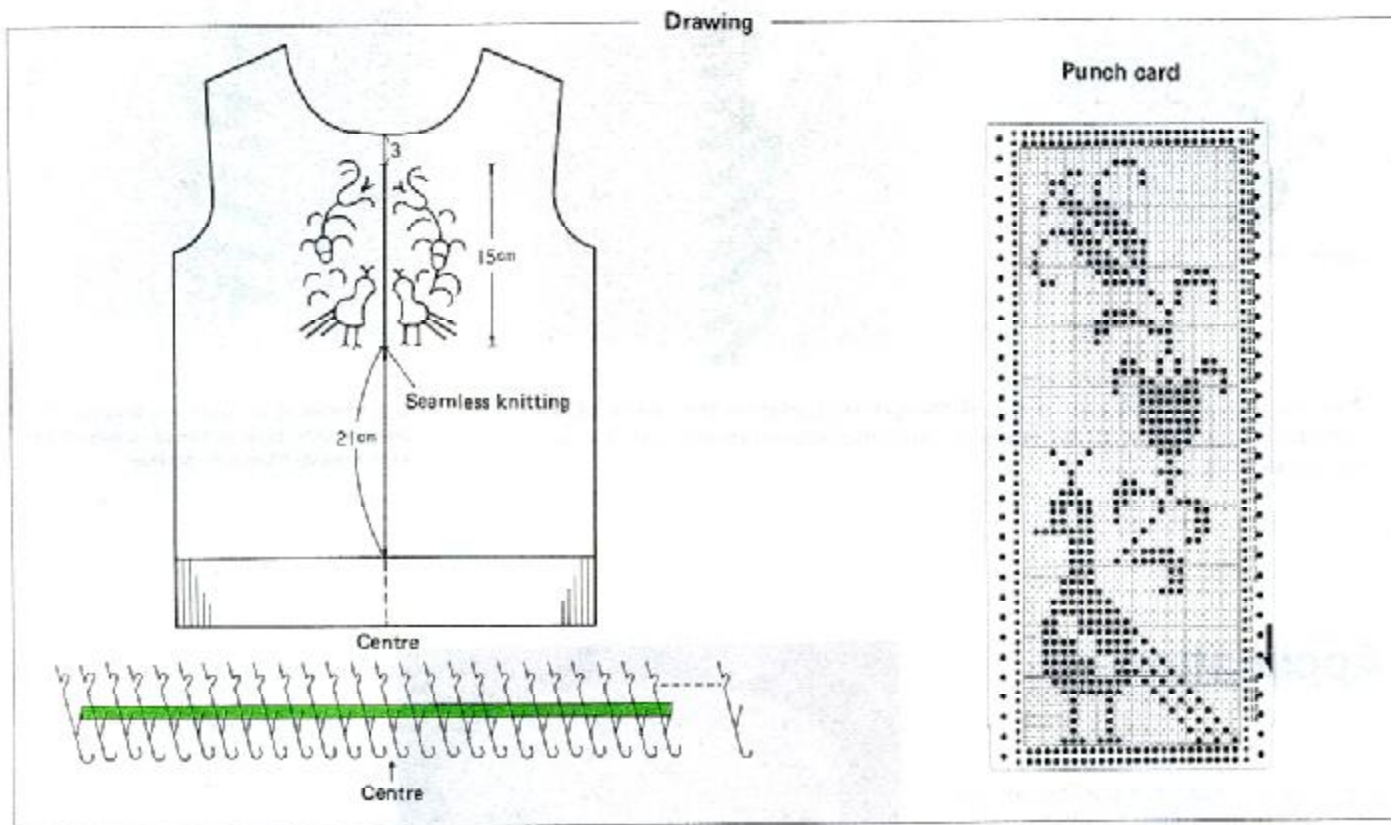

How to use a 48 stitches pattern with a punch card using a cast-on thread without seams

Right side

Knit upto the starting point of the motif. Put a reference mark on the centre of the swatch and take all the stitches off on waste yarn. Place the right hand half of the swatch back onto the machine with the centre starting at the 13th needle on the left. Set the punch card and select the needles, then knit one row of pattern knitting to the left ★ Hang the cast-on thread over the yarn leading from the swatch to the carriage, very loosely, as shown in the diagram. Knit two rows ★ Repeat from ★ to ★. Upto the end of the motif pattern. Take the stitches off on waste yarn. The first side is now complete.

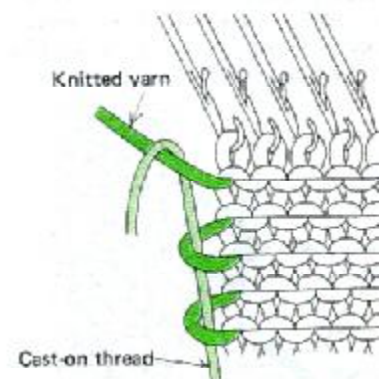

Left side

Take the punch card out of the knitting machine, turn it back to front and replace it. Pick up all the stitches on the left side of the garment and place these onto the machine in the same manner. Set the punch card and select the needles from right to left and knit two pattern rows. Pick up a loose end stitch which is around the cast-on thread and place this on the right end needle. Knit two rows and repeat. Continue this procedure upto the end of the motif pattern, take the stitches off on waste yarn.

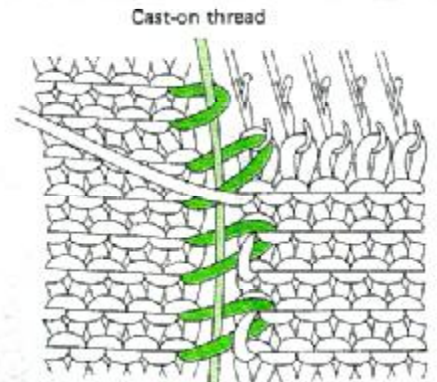
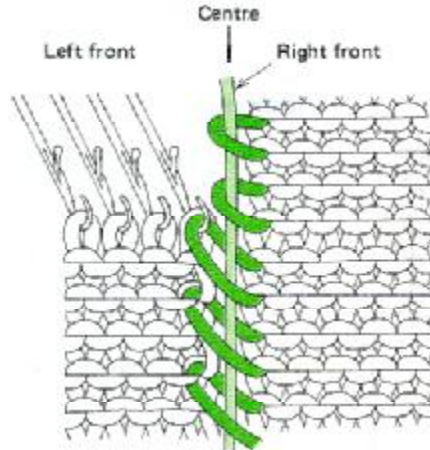
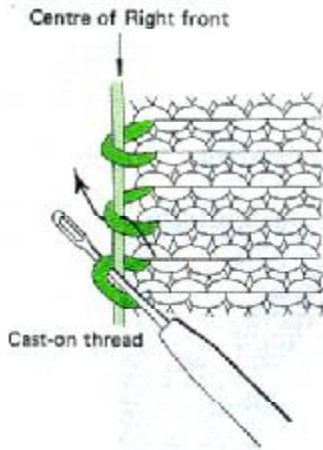

Pick up both left and right sides of the garment, placing the centre of the garment at the centre of the machine, and continue knitting remaining part of the garment.

N.B. If picking up loose end loops on the carriage side, pick up the loop behind the yarn leading from the carriage.

Application

Using these methods it is possible to produce a variety of designs. Example: Table Cloth.

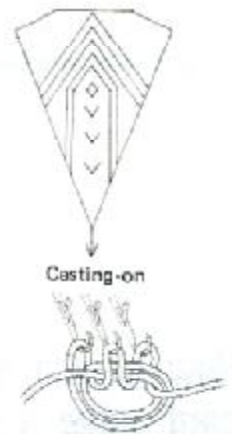

When casting on from a point, then increasing. Use method cast-on (3) on page 77. When increasing bring forward an empty needle forward to position 'B' on the side nearest the carriage.

When increasing pick up a looped stitch and hang it on to the empty needle on the opposite side of the carriage.

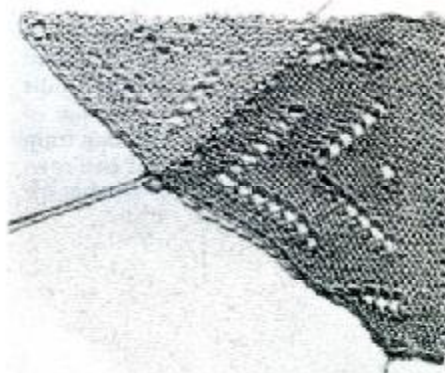
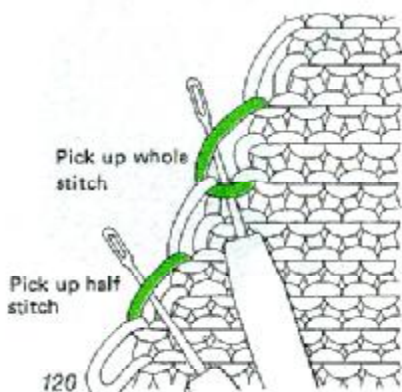

6 Reversible Knitting



A) Horizontal quilt knitting

The front side is tuck stitch pattern and the wrong side is patchwork.

A Blue
B Yellow
C Beige

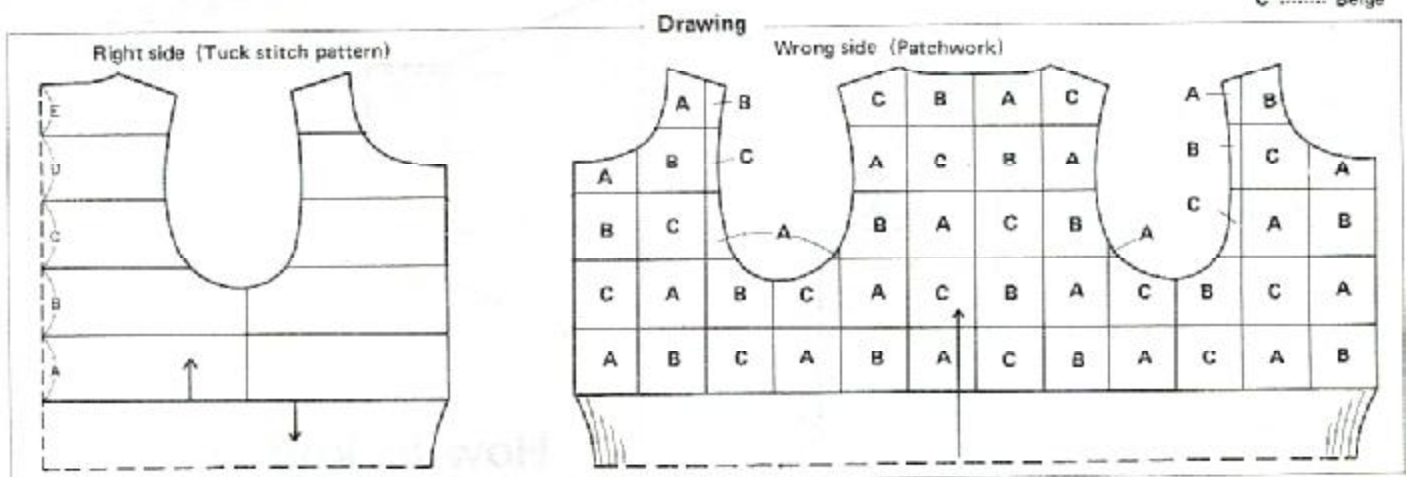

How to knit quilt knitting

① Knit the first part of the front (A) in tuck stitch, then take the stitches off on waste yarn.

② Knit the first row of the patchwork for the wrong side and seam them together using the method on page 119 and 120. Pick up all the stitches for the first row of patchwork and place them onto the needles.

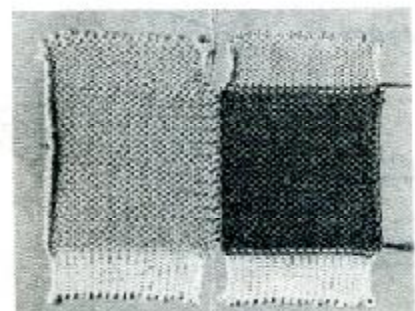
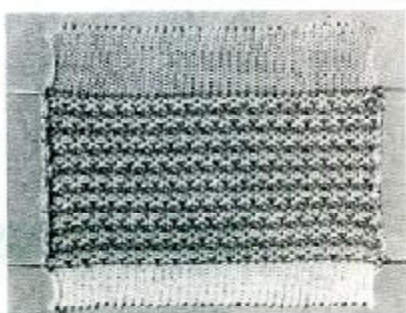

- ③ Hold the right side of the front towards you, and pick up all the stitches and place them onto the needles. Set the tension dial to a lower number and knit three rows with a (two-fold) fine yarn.
- ④ Knit the second part of the front (B) in tuck stitch, then take the stitches off on waste yarn.
- ⑤ Pick up the sinker loops of the last row of the (two-fold) yarn for one part of the patchwork and place them onto the needles. Knit the second row of the patchwork for the wrong side, as in item A) ②. Pick up all the stitches for the second row of patchwork and place them onto the needles. Hold the right side of the front towards you, pick up all the stitches and place them onto the needles. Set the tension dial to a lower number and knit three rows with the (two-fold) fine yarn.

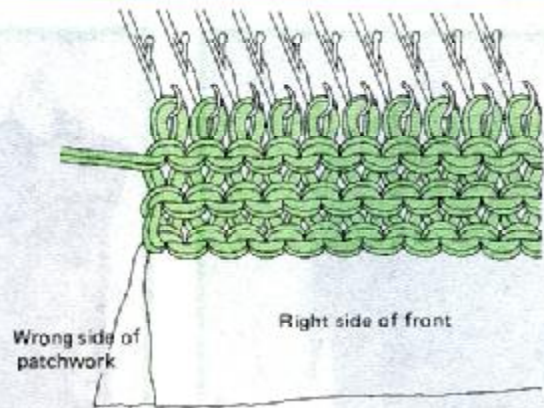

⑥ Repeat steps ④ – ⑤ upto the shoulder line.

B) Quilt knitting with a check pattern bulky knitting machine)

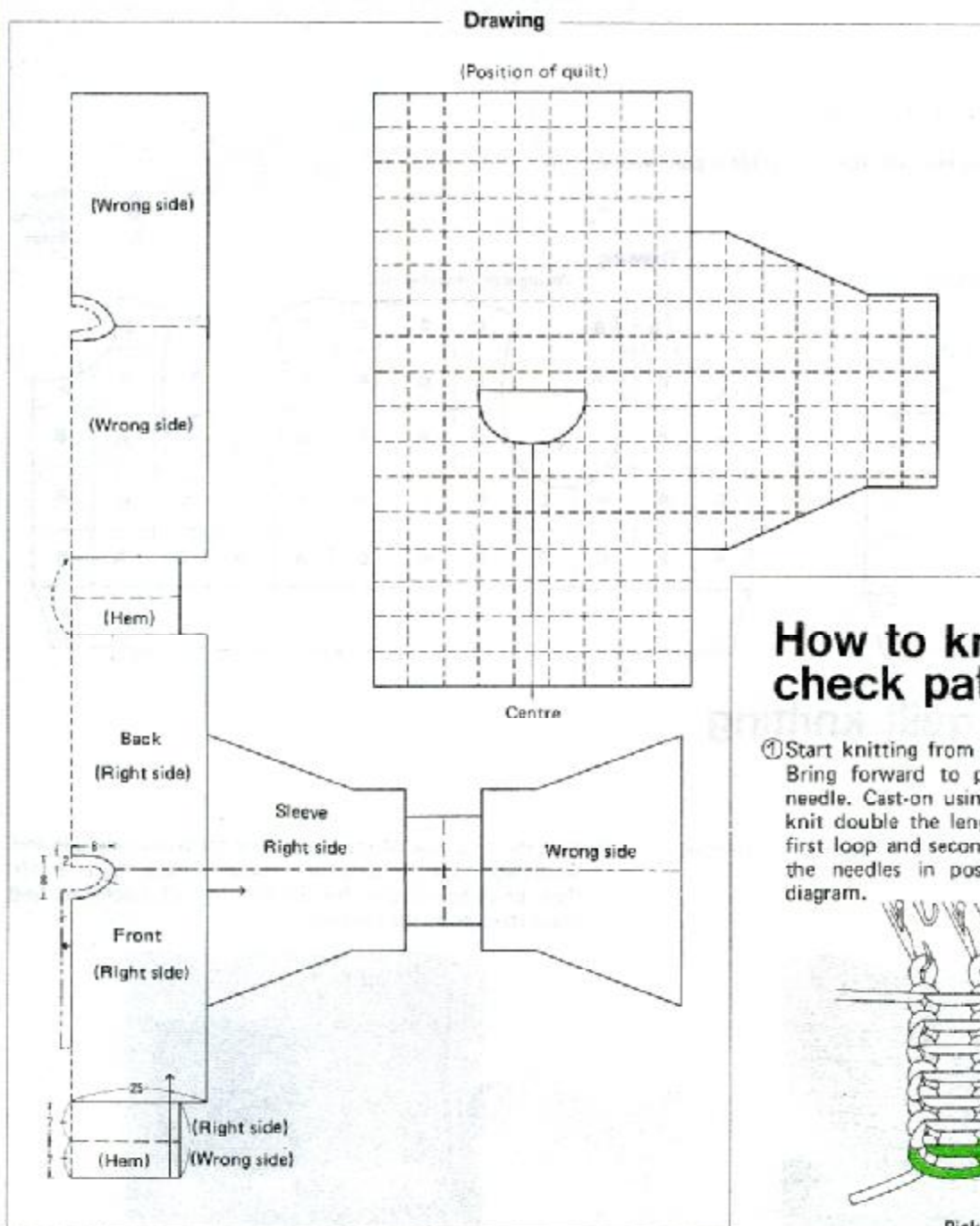

How to knit a check pattern

- ① Start knitting from the hem of the front body. Bring forward to position 'B' every alternate needle. Cast-on using the 'e' wrap method and knit double the length of the hem. Pick up the first loop and second loop and place them onto the needles in position 'A' as shown in the diagram.

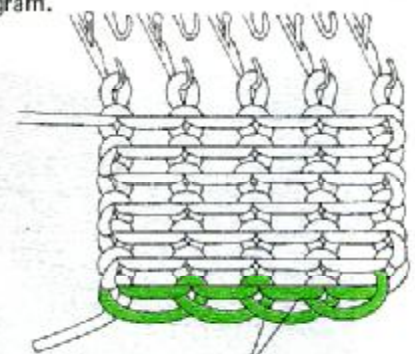

- ② Select every 9th needle and transfer these stitches to the adjacent needles and knit 14 rows with a thick yarn. Knit one row with a fine (mohair) yarn at tension dial 'O'. Repeat step ② according to the pattern. When knitting the front openings knit the left and right sides separately.
- ③ Knit up to the hem point of the right side of the back, transfer every other needle to the adjacent needle. Return all the empty needles to position 'A'. Knit double the length of the hem of the back.
- ④ Fold the hem, pick up the loops on the previous row and place these onto the needles in position 'A'. As shown in the diagram.
- ⑤ Tension dial to 'O' knit the wrong side of the body using the fine (mohair) yarn.
 - 1) Pick up the loops of the open stitches and place these onto the needles then bring these needle forward to position 'E'. Knit one row.
 - 2) Pick up two open stitch loops on the second row of the quilt and place these onto the needles and bring these needles to position 'E'. Knit one row. Repeat step 1 up to the twelfth row.

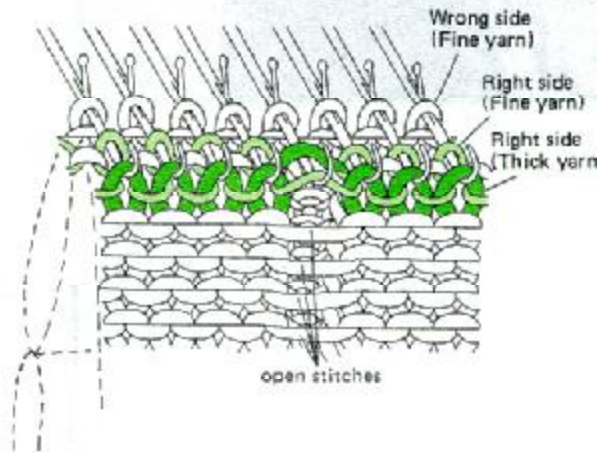
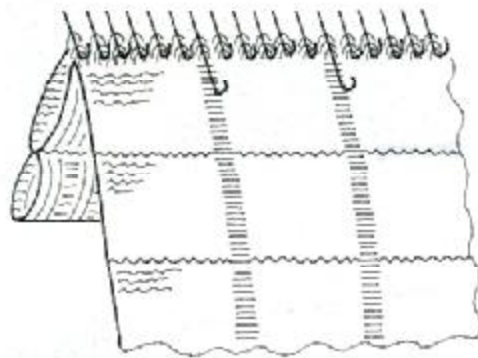
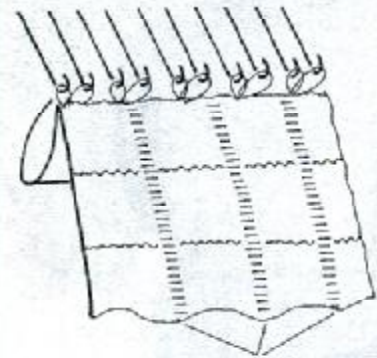

- ⑥ On the 13th row, pick up two open stitch loops and two stitches off the front body, place these onto the needles and knit one row. As shown in the diagram.
- ⑦ On the second quilt, pick up two open stitch loops on the first row of the second quilt, this will make a more effective pattern. Repeat steps ⑤-⑥ according to the pattern.

Application of quilt knitting

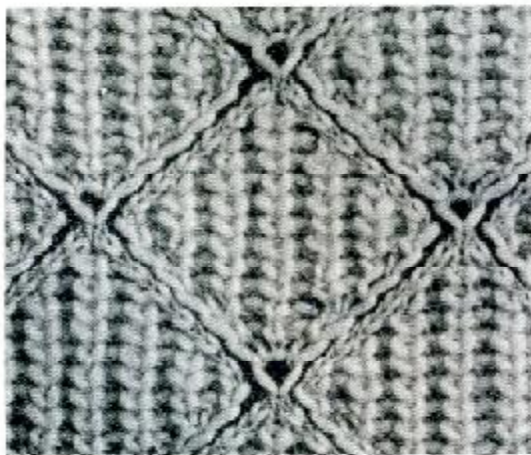

Diamond Pattern.

Knit the front side according to the symbol marks. When knitting the wrong side, pick up the stitch at the ⊖ symbol mark of the front side every other row.

Knitting symbol for front side

28	-	-	-	-	Y	X	⊖	Y	-	-	-	-	-	-	-	
25	-	-	-	-	Y	X	⊖	Y	-	-	-	-	-	-	-	
20	-	-	-	-	Y	X	⊖	Y	-	-	-	-	-	-	-	
15	⊖	Y	⊖	X	-	-	-	-	-	-	-	-	-	Y	⊖	
10	-	-	-	-	Y	X	⊖	Y	-	-	-	-	-	-	-	
5	-	-	-	-	Y	X	⊖	Y	-	-	-	-	-	-	-	
1	-	-	-	-	Y	X	⊖	Y	-	-	-	-	-	-	-	
	1	2	3	4	5	6	7	8	9	10	11	12	13	14	15	16

7 Shirring



When using shirring elastic it is better to knit the garment in fine yarn for the best effect.

Drawing

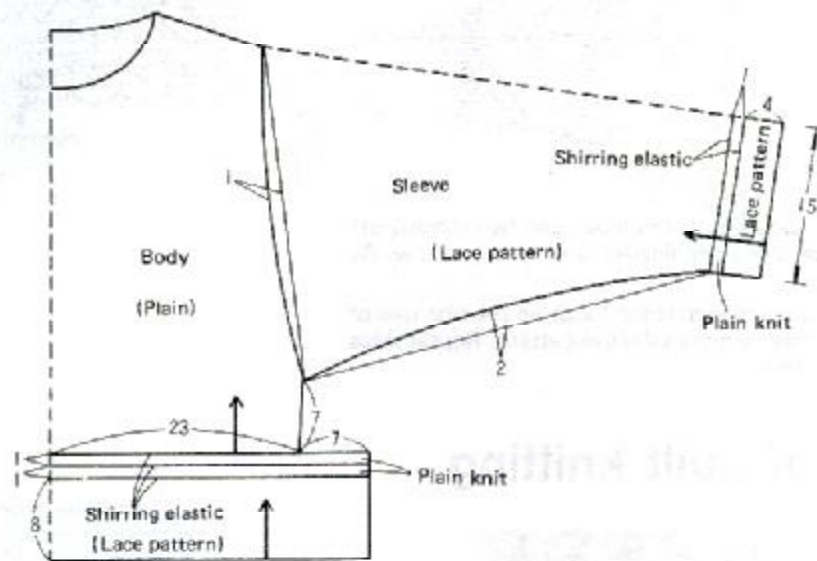

How to weave with shirring elastic

A) Using the front side as the front, weaving over every alternate needle

Use this method for gathering.

- ① Knit upto the shirring point, push every alternate even number needle to position 'D', set the weaving pattern brushes to W.T
Knit one row with the shirring elastic.

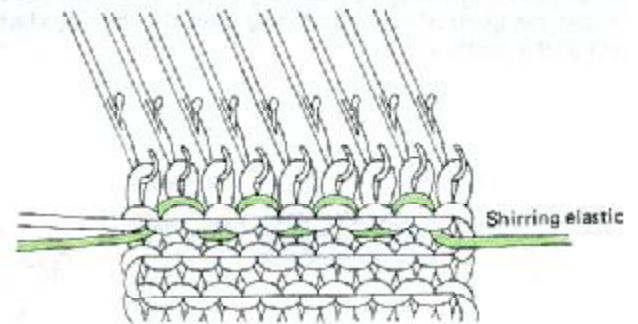
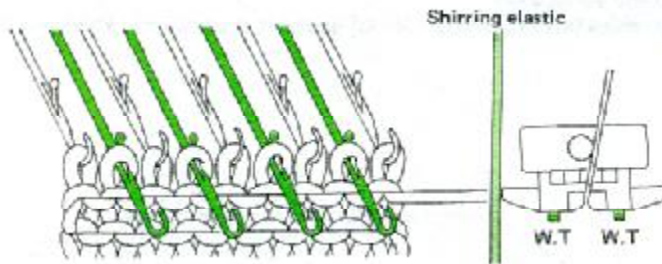

- ② Repeat this method, for depth of shirring required. The amount of needles selected to 'D' position depends on the garment you are making. e.g. Waistline on a dress: you would use approximately every 3rd or 4th needle.

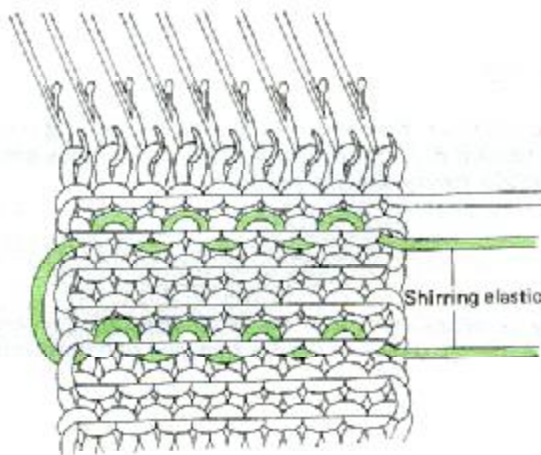

- ③ Waistband on a skirt: select every alternate needle. Shirring for 2-3 rows depending on the depth of the waistband required.

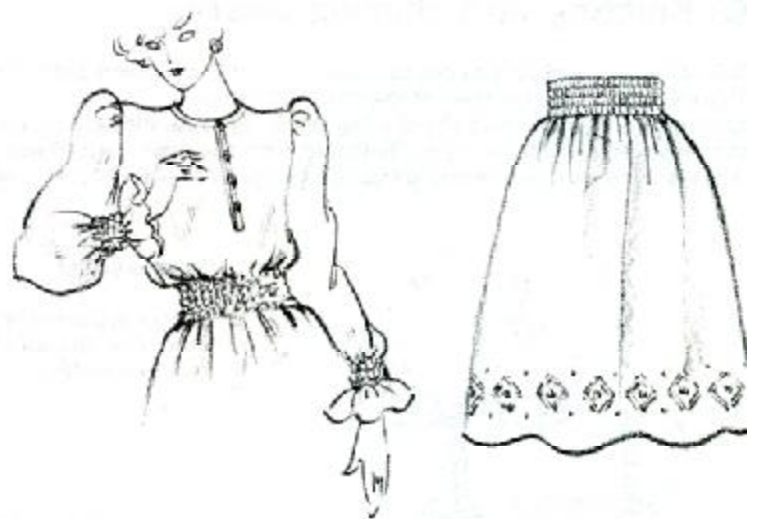

B) Using the wrong side as the front, weaving over every alternate needle

Weave the shirring elastic in the same manner as method A). However, pick up the loops from the previous row and place these on the needle hooks to hide the shirring elastic.

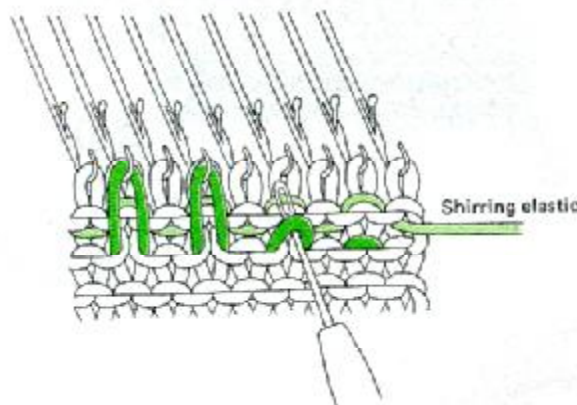

How to gather

Before gathering it may be necessary to iron the fabric depending on the yarns used.

To give the garment extra gathering, pull the shirring elastic at both sides until correct width of garment is obtained. Then sew the ends of the elastic in.

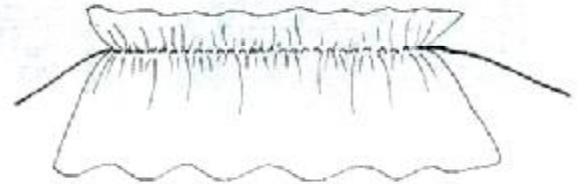
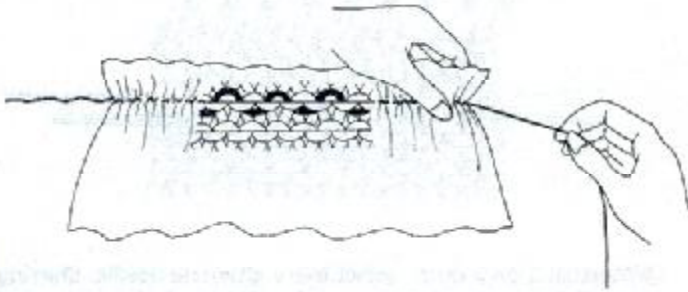

C) Knitting with shirring elastic

Following this method you can use either side of the garment as the front. This method is used for small amounts of gathering.

Knit upto one row before the shirring point. Increase the tension by two numbers. Knit one row. Thread the shirring elastic into the yarn feeder. Knit one row. Re-thread with the main yarn. Reset the tension dial to the main tension and continue knitting. If required, knit on row of shirring elastic a few rows of plain knitting and another row of shirring elastic.



How to gather

Before gathering it may be necessary to iron the fabric depending on the yarns used. Cut the shirring elastic as shown in the diagram, and pull both end to the required width.

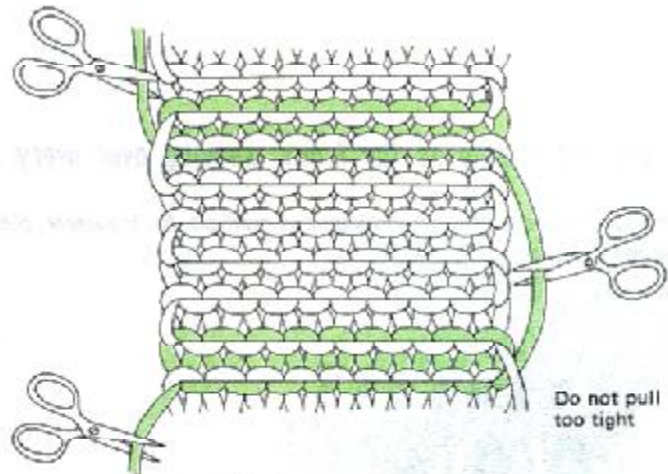

B) Large scallop using pull-up stitch

Knitting symbol

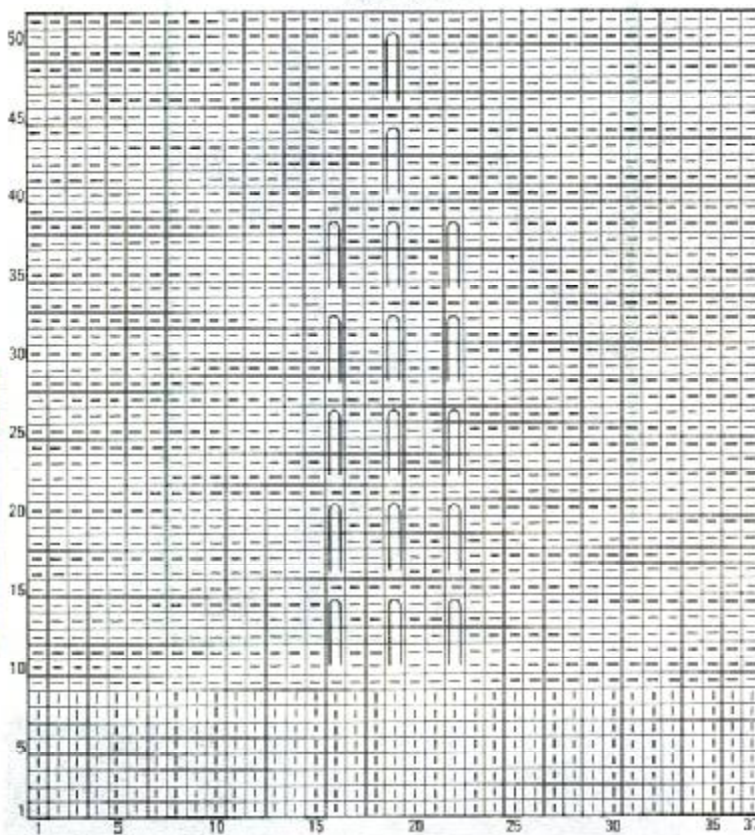

① E.g. if scallop requires 37 needles, calculate how many scallops you would require for your pattern, add two extra needles for the seams. Cast-on using the 'a' wrap method.

② Knit 8 rows with plain knitting, then take the stitches off on waste yarn.

③ Hold the swatches with the front side facing you. Replace the stitches back onto the machine. Knit two rows.

④ Set H.C.L to H (Push button machine to II) and select the needles to position 'E' according to the symbol marks. Knit 4 rows. Reset H.C.L to P (Push button machine to I) and knit two rows. Repeat these steps according to the pattern.

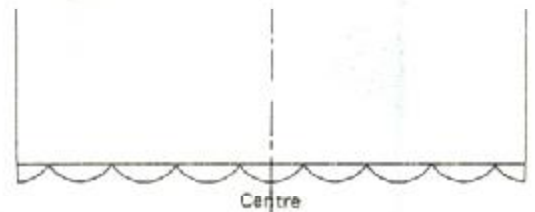

C) Scalloped edge using a lace pattern, transferring by hand

Knitting symbol



① Bring forward required needles to position 'B'. Decide how many needles are required for the scallop and calculate how many scallops will be required for the garment plus two extra needles for the seams. Knit several rows with waste yarn. Change to the main yarn and knit 8 rows plain knitting. Pick up the edge stitches and place these onto the hook of the needles. (Elastic hem)

② Increase the tension dial by three numbers. Knit one row. Reset the tension dial to the main tension. Knit one row.

③ ★ Transfer the stitches according to the symbol marks to form a lace pattern. Knit two rows and repeat ★ from ★ to ★.

D) Scallop using 1 x 1 rib (latch tool method)

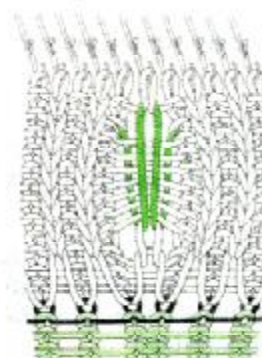
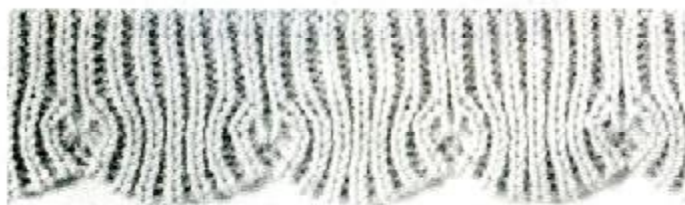

After making the 1x1 rib (latch tool method), on every 12th stitch, unravel the eight stitches and pull up the bottom stitch, placing this onto the hook of the needle as shown in the diagram.

Cast-on for 1x1 rib (Latch tool method)
Cast-on thread
Waste knitting

9 Smocking



Drawing

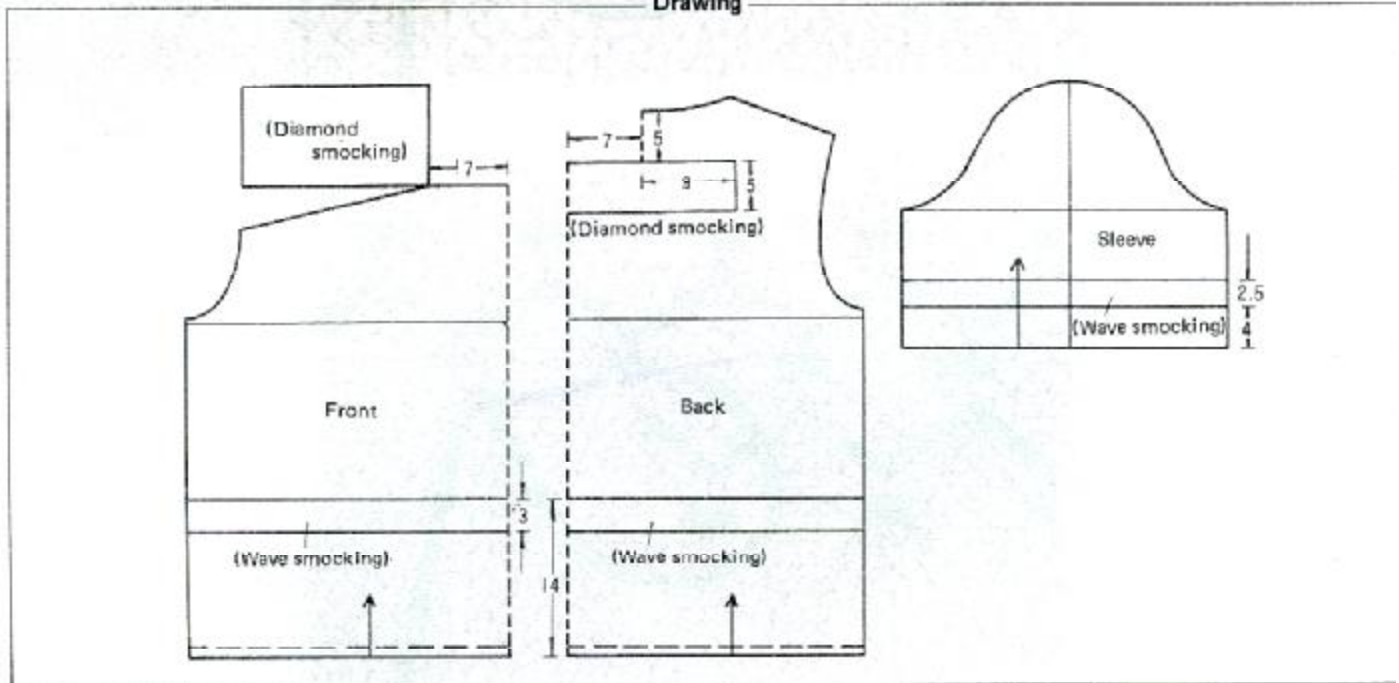

Used on yokes, cuffs, waistbands etc.

(Hints for knitting)

Prepare several contrast yarns for smocking. Use ribbed stitches.
A tapestry needle is required.
Finer or soft yarns preferable for smocking.

To make correct size of garment, it is better to take a tension gauge.

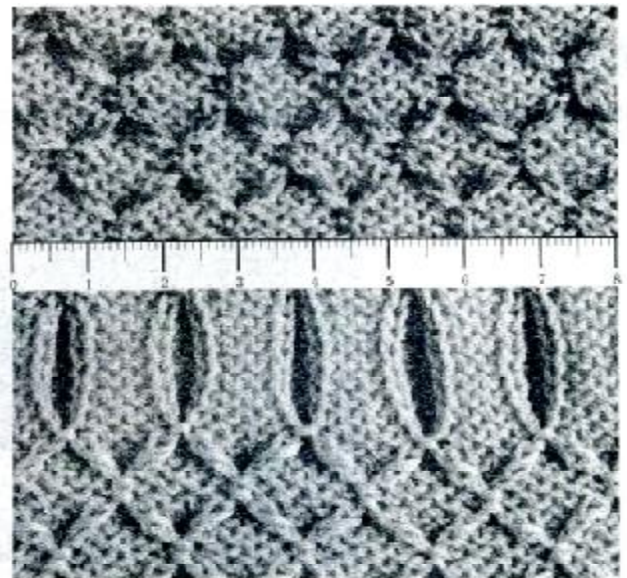

A) Diamond smocking

This method gives a softer result. To obtain diamond smocking follow the numbers on the diagram in numerical order and do not pull the yarn too tight.

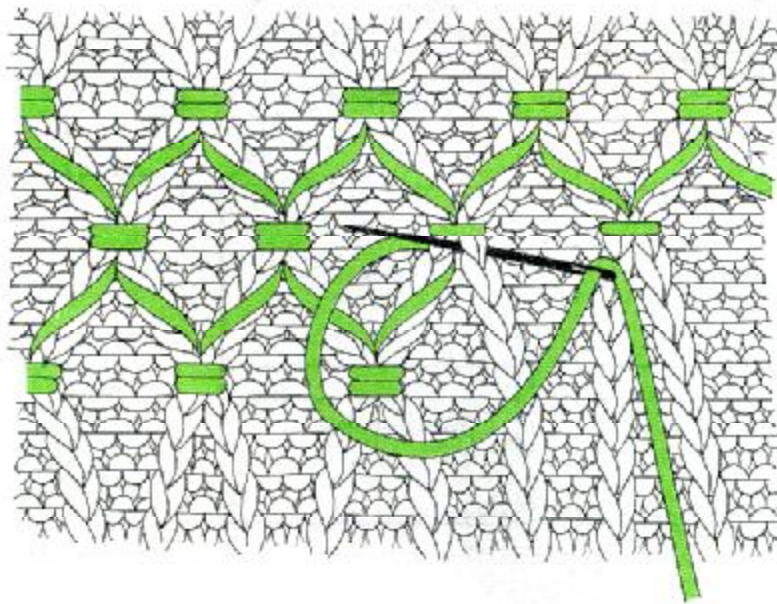
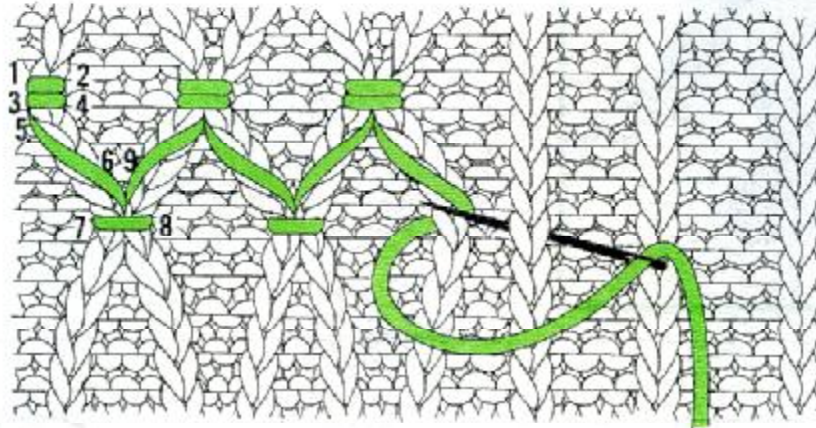

B) Honeycombe smocking

Follow the numbers on the diagram in numerical order and do not pull the yarn too tight.

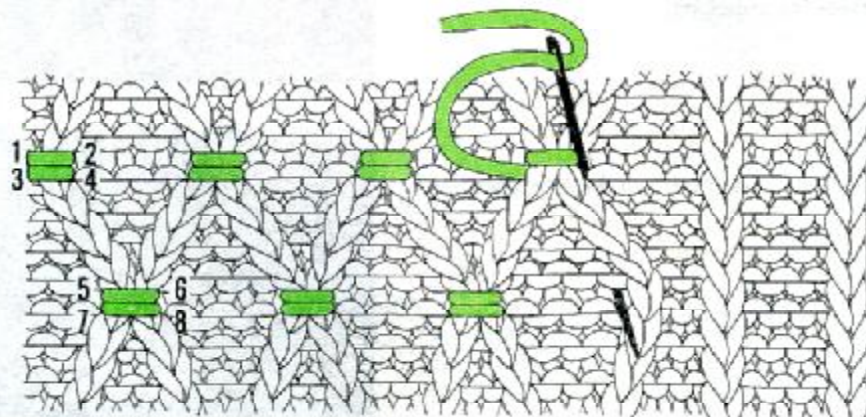

C) Outline smoking

Follow the numbers on the diagram in numerical order and do not pull the yarn too tight.

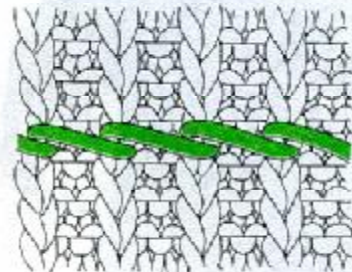
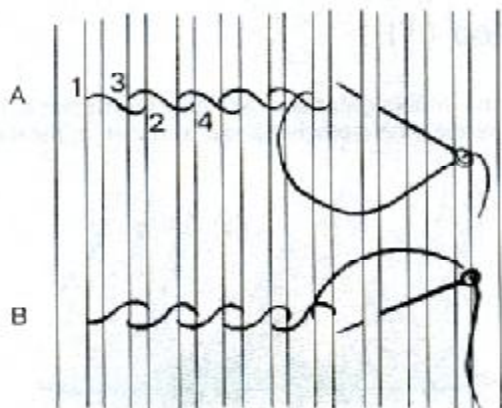

D) Cable smoking

Follow the numbers on the diagram in numerical order and do not pull the yarn too tight.

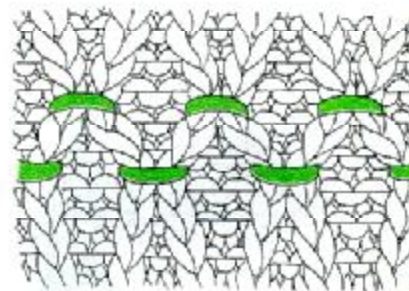
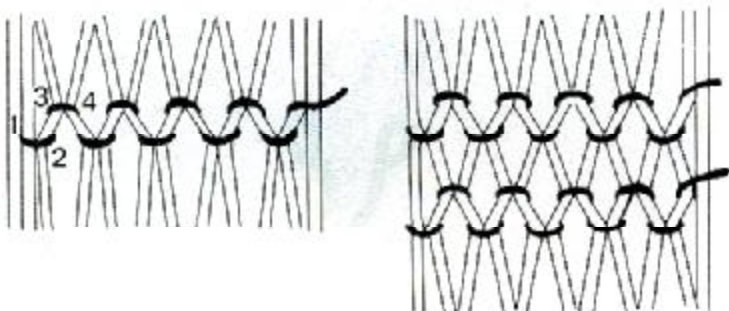

E) Wave smoking

Follow the numbers in numerical order as shown in the diagram and do not pull the yarn too tight.

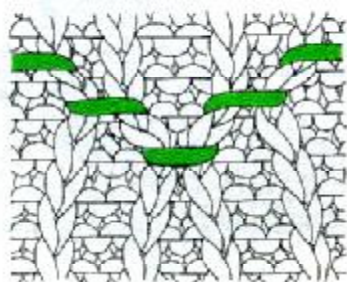
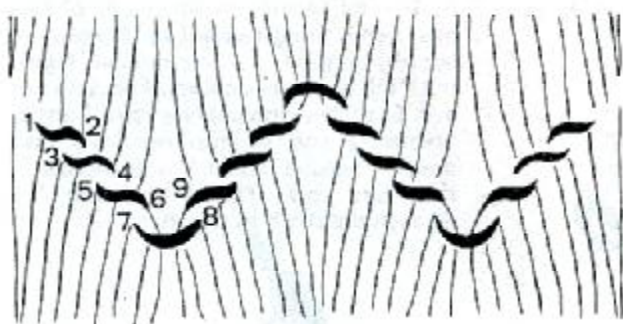

F) Cross smoking

Follow the numbers in numerical order as shown in the diagram and do not pull the yarn too tight.

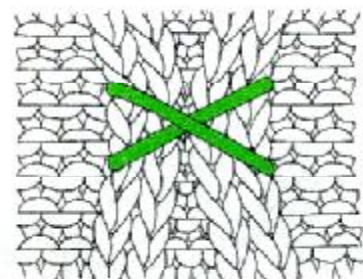
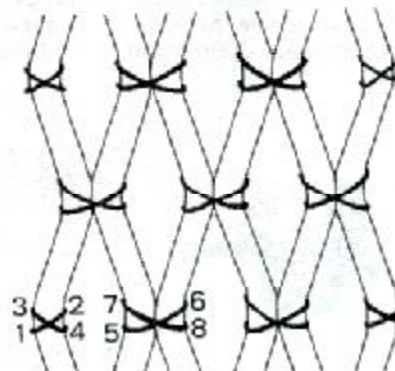

10 Bobbles



Bobbles which are made on the knitting machine.

A) Method (I)

- ① Knit upto the bobble point and take off two stitches either side of the centre needle onto a crochet hook, as shown in the diagram.

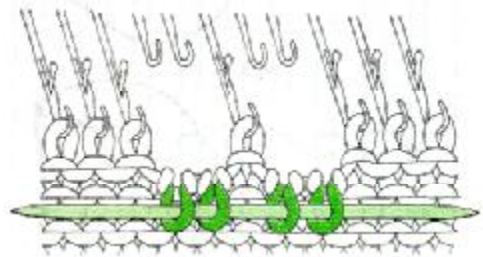

- ② Knit the centre needle by hand with the yarn to be used for the bobbles, leaving enough yarn for the bobbles on the carriage side.

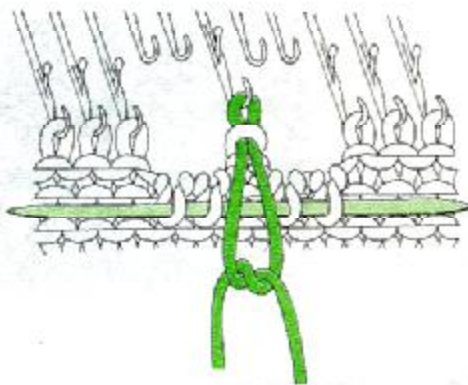

- ③ Twist the yarn and place this onto the needles either side of the centre needle as shown in the diagram.



- ④ Knit one row on the needles either side of the centre needle, by hand, using the bobble yarn, as shown in the diagram.



- ⑤ Pick up the lower loop and place these onto needles 1 and 5 as shown in the diagram.

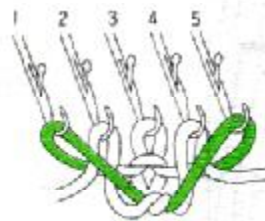

- ⑥ Set the HCL to H (Push button machine to II). All needles on either side of needles 1 to 5 bring forward to 'E' position. Set the tension dial one number higher than the main tension and knit six rows over 5 stitches with bobbles yarn. Transfer needles 2 and 4 onto needle 3 then transfer needles 1 and 5 onto needle 3. Knit one row. Thread the yarn end through the stitch to tie off.

These stitches are on the E position needles

These stitches are on the E position needles

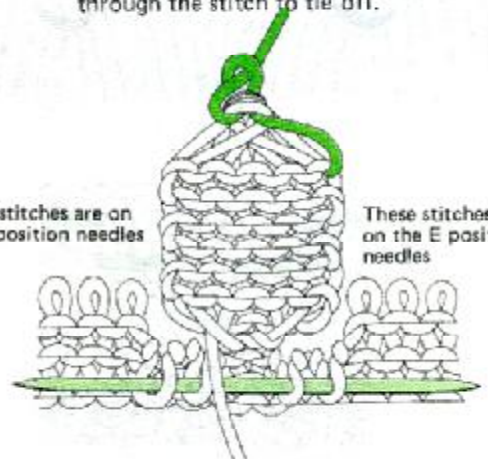

⑦ Push back the centre needle to position 'A'. Replace the stitches on the crochet hook into the hooks of needles 1, 2, 4 and 5. Push back needles in 'E' position to 'D' position and knit four rows with the main yarn.

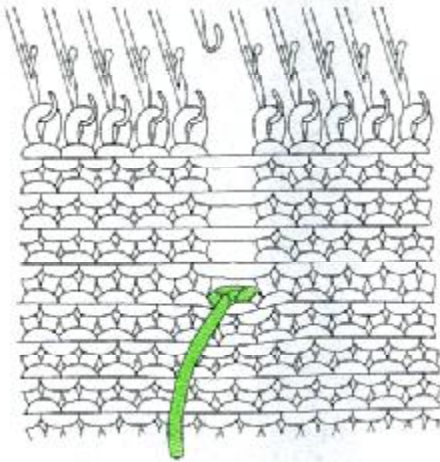

⑧ Bring the centre needle to 'B' position. Replace the last stitch of the bobble onto the centre needle. Hang the end of the yarn onto needles 2 and 4 as shown in the diagram.

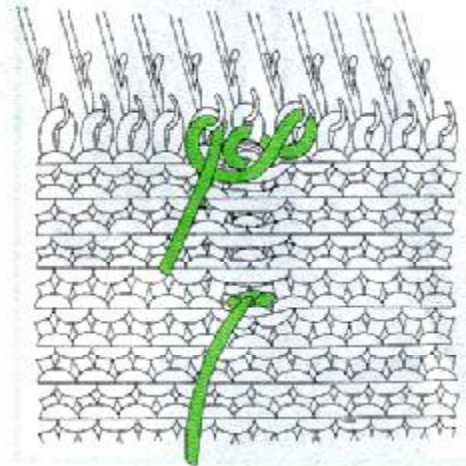

B) Method (2)

Knitting symbol

	-	-	-	-	-	-	-	-	-	-	-	-	-	-	-	-	-	-	-
	-	-	-	-	-	-	-	-	-	-	-	-	-	-	-	-	-	-	-
	-	-	-	-	-	-	-	-	-	-	-	-	-	-	-	-	-	-	-
	-	-	-	-	-	-	-	-	-	-	-	-	-	-	-	-	-	-	-
6	-	-	-	-	-	-	-	-	-	-	-	-	-	-	-	-	-	-	-
5	-	-	-	-	-	-	-	-	-	-	-	-	-	-	-	-	-	-	-
4	-	-	-	-	-	-	-	-	-	-	-	-	-	-	-	-	-	-	-
3	-	-	-	-	-	-	-	-	-	-	-	-	-	-	-	-	-	-	-
2	-	-	-	-	-	-	-	-	-	-	-	-	-	-	-	-	-	-	-
1	-	-	-	-	-	-	-	-	-	-	-	-	-	-	-	-	-	-	-
	1	2	3	4	5	6	7	8	9	10	11	12	13						



① Knit up to the bobble point. Transfer the 4th and 5th stitches to the 3rd needle and the 6th stitch to the 4th needle. Transfer the 9th and 10th stitches to the 11th needle and transfer the 8th stitch to the 10th needle.

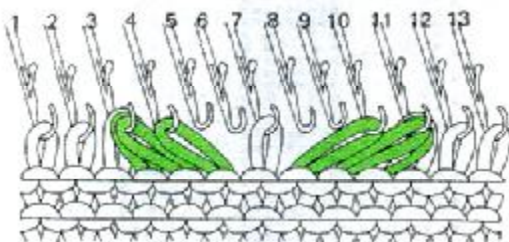

② Make five stitches by hand using the bobble yarn, as shown in the diagram.

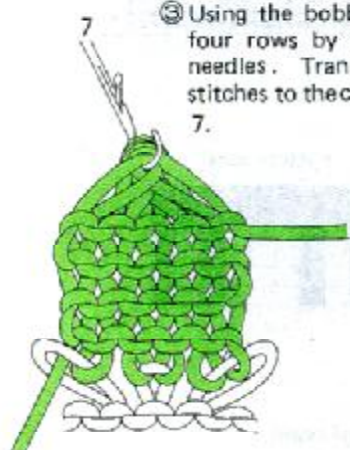
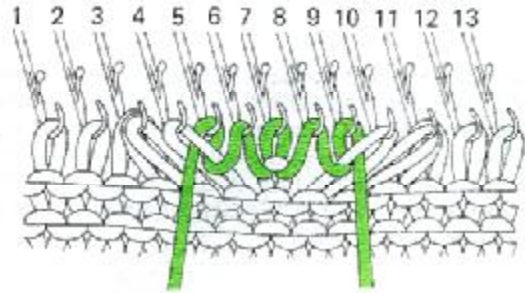

③ Using the bobble yarn knit four rows by hand over 5 needles. Transfer all five stitches to the centre needles 7.

④ Transfer stitches 4, 5, 6, 8, 9 and 10 back to their original places. Pick up the first row of the bobble stitches on either side of the centre needle. Then continue to knit.

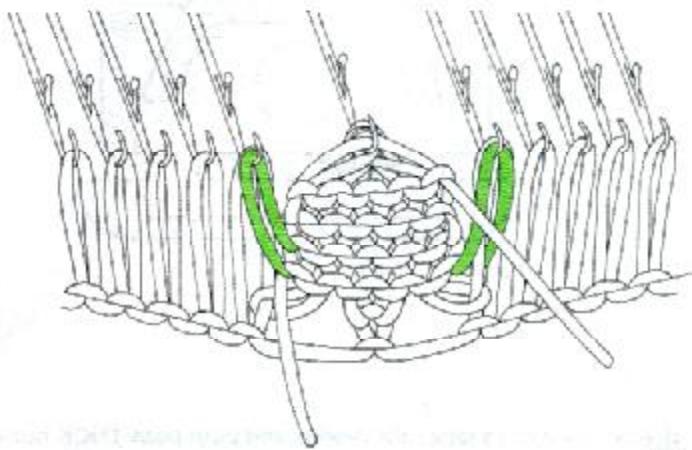

11 Braid



A) Using both TUCK buttons



① Arrange the needles for the braid as shown in the diagram. Place all the needles at position 'E'.

Push these needle back to position A

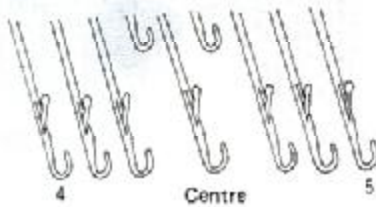

② Make an 'e' wrap cast-on and knit three rows with the main yarn from the right.

③ Make a punch card (or pattern card for electronic knitting machine) as shown in the diagram and place it in the knitting machine. Set the change knob to K.C. (in case of KH860/881/840 set the end needle selection cam to the non-working position). For the KH840 knitting machines which do not have this facility, take the 'A' position needles out of the machine. For the KH910 electronic knitting machines set the change knob to KC(1).

Punch card

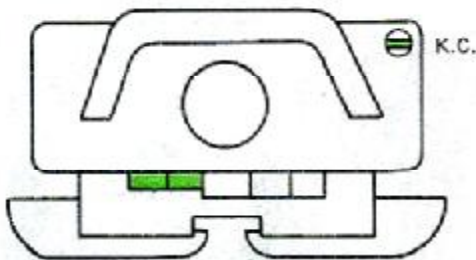
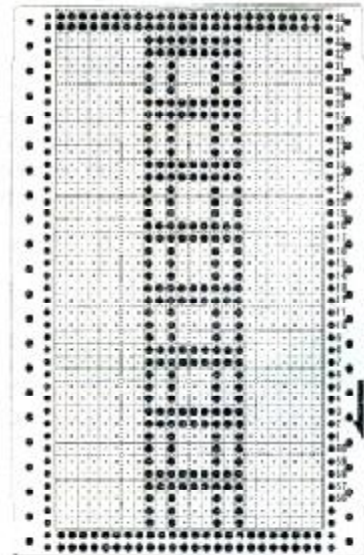

Pattern card



④ Knit one row to select the needles and push both TUCK buttons. Knit the required length of braid.

B) Using right PART button

① When using a punch card set the K carriage as shown in the diagram and set the card lock lever to '●'. Knit required length of braid.

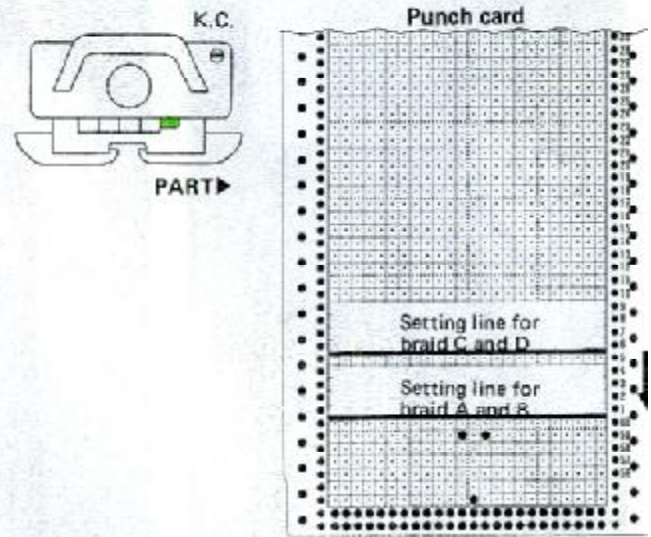

- Braid A, C and D, set the end needle selection cam to the non-working position.
- Braid B, set the end needle selection cam to the working position.

A Bring forward the needles from the left 3rd needle to the right 4th needle and knit the braid according to the symbol marks on the punch card as shown in the diagram.

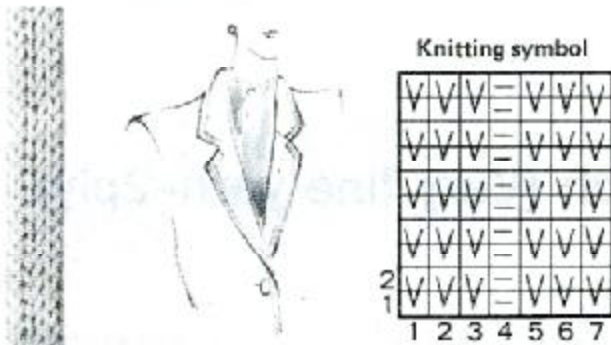

B Bring forward the needles from the left 3rd needle to the right 4th needle and knit the braid according to the symbol marks on the punch card as shown in the diagram.

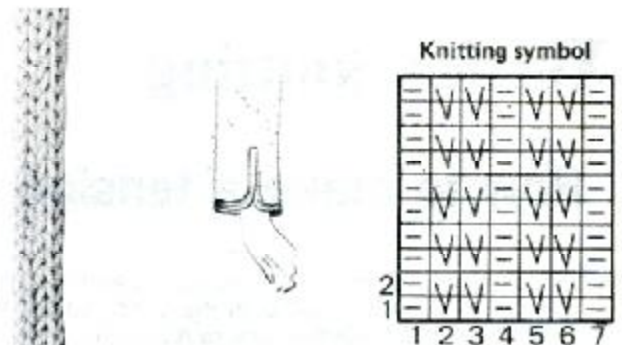

C Bring forward the needles from the left 3rd needle to the right 4th needle and knit the braid according to the symbol marks on the punch card, as shown in the diagram.

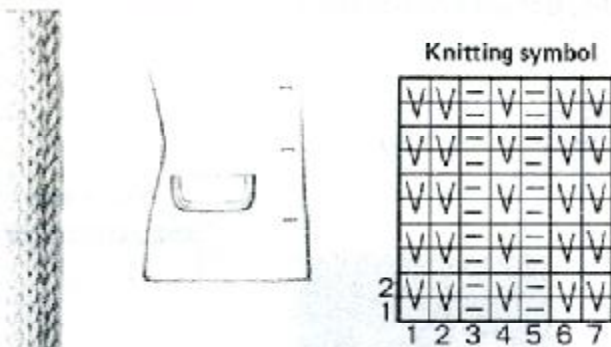

D Bring forward the needles from the left 4th needle to the right 5th needle and knit the braid according to the symbol marks on the punch card, as shown in the diagram.

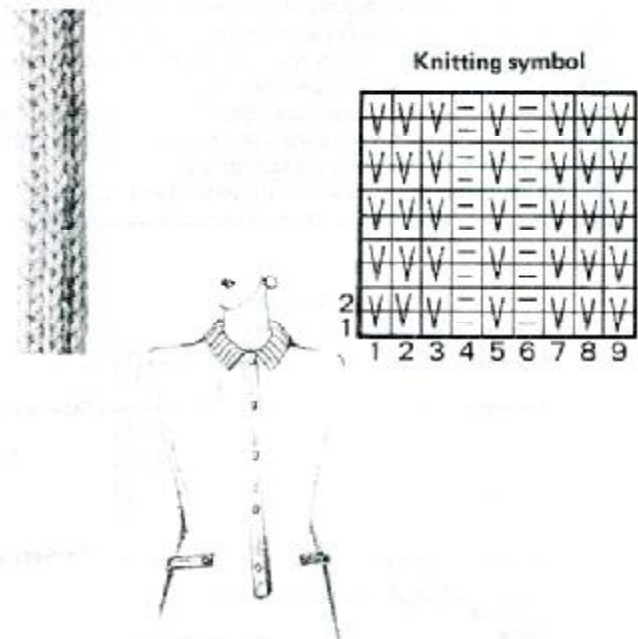

12 Pleated Skirt



12

Vertical knitting

How to make a tension swatch (Very fine yarn-2ply)

- ① Bring forward all the needles between L60th and R60th needles to B position and push the L41st, L17th, R8th, R32nd and R56th needles back to A position.
- ② Knit about 10 rows of plain knitting with waste yarn on T.D. 3.
- ③ Knit one row with the CAST-ON THREAD.
- ④ Bring forward all needles from B position to E position.
- ⑤ Cast-on with the main yarn by using the LATCH TOOL.
(Make the stitches missing the needles at position L4st, L17th, 88th, R32 and R56th needles.)
- ⑥ Knit 2 or 4 rows in plain knitting on T.D. 3.
- ⑦ Set the punch card and prepare for lace pattern knitting.
- ⑧ Knit 20 rows in lace pattern knitting.
- ⑨ Change the yarn to a contrast colour in yarn feeder "A" and knit 2 rows.
- ⑩ Rethread the main yarn into yarn feeder "A" and knit 60 rows in lace pattern knitting.
- ⑪ Knit 2 rows with a contrast colour yarn.
- ⑫ Knit 20 rows of the lace pattern with the main yarn.
- ⑬ Crease the pleats with a steam iron and measure them.

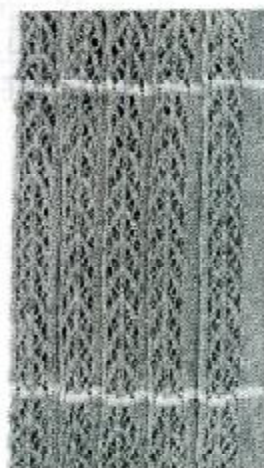
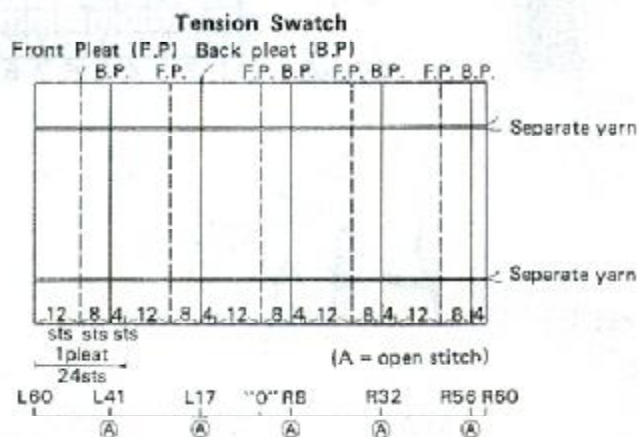
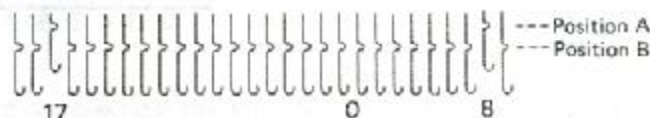

Punch card

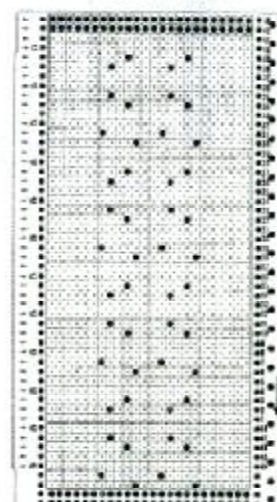

How to determine the knitting gauge

① Rows. (Length of the knitting)

- 1) Measure the length of 60 rows (inside the two lines knitted with a different colour yarn).
- 2) Set the knit-Leader regulator for cm and mm.

② STITCHES. (Width of the knitting)

- 1) Measure the width of the pleats (between two front pleats).
- 2) Calculate your own size.

Ex.	96.0 cm	(Hip size)
	+ 2.3 cm	(width of one pleat)
	- 41.7 (42 pleats)	(the number of pleats required for the skirt)

If your hip size is 96 cm, 42 pleats are necessary to make your own skirt.
Only 7 pleats can be made in the width of 200 needles, therefore, 6 pieces of the same are necessary for the skirt.

	42 pleats	(the number of pleats required for the skirt)
	+ 7 pleats	(number of pleats in one piece)
	= 6 pieces	(the number of pieces required for the skirt)

How to make a pleated skirt (Vertical knitting)

- ① Bring forward all the needles between L88th and R80th to B position.
- ② Push the following 6 needles back to A position as shown in the following figure.
- ③ Knit 21 rows with waste yarn in plain knitting on T.D.3.
- ④ Knit one row with the CAST-ON THREAD.
- ⑤ Bring forward all the needles from B position to E position.
- ⑥ Cast-on with the main yarn by using the latch tool. (Make stitches missing needles at A position.)
- ⑦ Knit 2 rows on T.D. $3\frac{2}{3}$ in plain knitting.
Knit the last 2 rows with the main yarn on T.D. 2 and one row with the CAST-ON THREAD.
Knit 20 rows of plain knitting with waste yarn on T.D. 3.
- ⑧ Set the punch card and prepare for lace pattern knitting.
- ⑨ Knit the length of the skirt in lace pattern knitting. (While knitting, adjust the tension dial at the indication lines.)
- ⑩ Knit the last 2 rows with the main yarn on T.D. 2 and one row with the CAST-ON THREAD.
Knit 20 rows of plain knitting with waste yarn on T.D. 3.
- ⑪ Crease the pleats and press the seams with a steam iron.
- ⑫ Knit the waist band.
 - 1) Pick up the stitches as shown in the diagram.

Stitch to be picked up
 Stitch to be overlapped

 - 2) Knit the number of rows required for double the length of the waist band in plain knitting, and bind off all the stitches.
- ⑬ Fold the waist band with elastic inside and pin it.
- ⑭ Seam the waist band and give it a final ironing

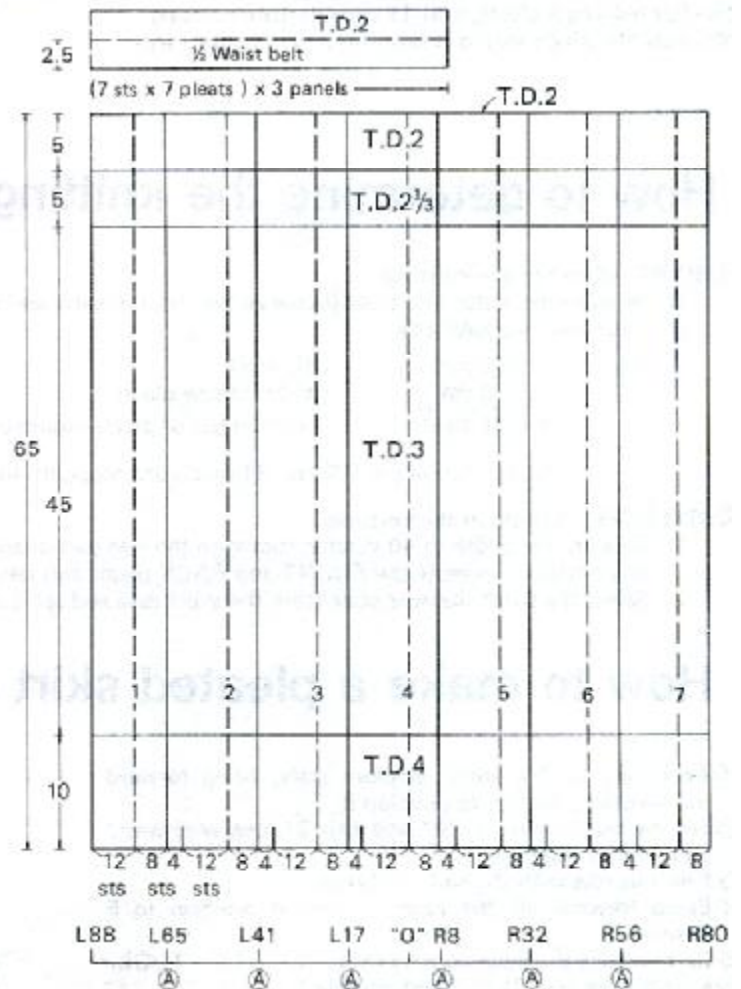

Lateral knitting

How to make a tension swatch (Fine yarn-3ply)

- ① Bring forward 60 needles to position B. (30 needles on both sides of the centre mark "0".)
- ② Cast-on with a finished edge ('e' wrap) by hand.
- ③ Set the tension dial on "4" and knit 11 rows in plain knitting.
- ④ Set the tension dial on "0" and knit one row in plain knitting.
- ⑤ Set the tension dial on "4" and knit 2 rows in plain knitting.
- ⑥ Set the punch card and prepare for lace pattern knitting.
- ⑦ Knit the lace pattern up to step No. 38 of the punch card.
L-carriage is now on the left side of the machine.

⑧ FRONT PLEAT

- 1) Change the yarn to a different colour in yarn feeder "A" and knit 2 rows at T.D. 4 in plain knitting.
- 2) Knit one row on T.D. 6 in plain knitting.
- 3) Knit one row on T.D. 4 in plain knitting.
- 4) Rethread the main yarn into yarn feeder "A" and knit 2 rows on T.D. 4 in plain knitting.

⑨ Continue to knit the lace pattern up to step No. 54 of the punch card.

⑩ BACK PLEAT

- 1) Knit 2 rows with the main yarn on T.D. 4 in plain knitting.
 - 2) Knit 2 rows on T.D. 0 in plain knitting.
 - 3) Knit 2 rows on T.D. 4 in plain knitting.
- Now one pleat is completed and make two more pleats by repeating steps ⑦ to ⑩ 3).

In order to make the yarn marks, hook a separate yarn into the hook of both 21st needles when knitting the top of the 2nd FRONT and BACK pleats.

- ⑪ After making 3 pleats, knit 12 rows in plain knitting.
- ⑫ Crease the pleats with a steam iron and measure them.

Tension Swatch

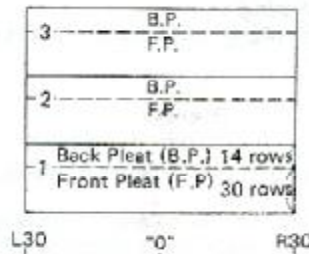

Punch card

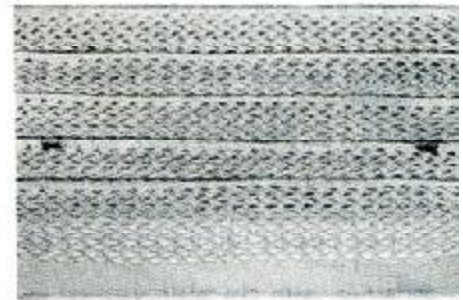
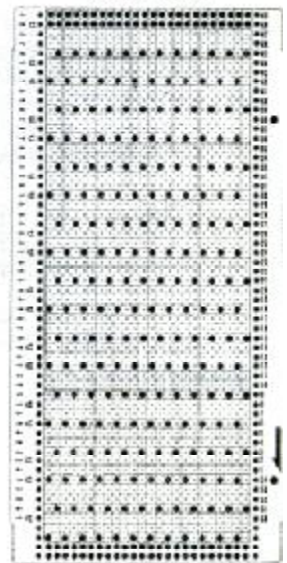

How to determine the knitting gauge

① ROWS. (Width of the knitting)

- 1) Measure the width of a pleat (between two front pleats) and take the mean average.
- 2) Calculate your own size.

Ex.	102 cm	(Hip size)
	÷ 3 cm	(Width of one pleat)
	= 34 pleats	(The number of pleats required for the skirt)

If your hip size is 102 cm, 34 pleats are necessary to make your own skirt.

② STITCHES. (Length of the knitting)

- 1) Measure the width of 40 stitches (between the two yarn marks).
It is better to measure the FRONT and BACK pleats and take the mean average.
- 2) Select the stitch measure scale from the sheet case and set it on the Knit-leader.

How to make a pleated skirt (Lateral knitting)

- ① According to the stitch measure scale, bring forward the necessary needles to position B.
- ② Set the tension dial on "4" and knit 21 rows with waste yarn in plain knitting.
- ③ Knit one row with the cast-on thread.
- ④ Bring forward all the needles from B position to E position.
- ⑤ Cast-on with the main yarn by using the LATCH TOOL.
- ⑥ Knit 2 rows on T.D. "0" and another 2 rows on T.D. "4" in plain knitting.
- ⑦ Set the punch card and prepare for lace pattern knitting.
- ⑧ Knit the pleats as before. (Refer to the instructions for making a tension swatch.)

- ⑨ After knitting the pleats, knit 20 rows with waste yarn in plain knitting and remove it from the machine.
- ⑩ Crease the pleats and press the seams with a steam iron.
- ⑪ Put them together inside out and seam the sides.
- ⑫ Knit the waist band.

Pick up the stitches as shown in the diagram.

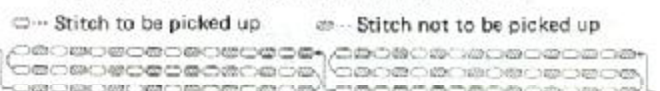

- ⑬ Fold the waist band with elastic inside and pin it.
- ⑭ Seam the waist band and give it a final ironing.

Skip-stitch and plain knitting

How to make a tension swatch (Fine yarn-3ply)

- ① Bring forward all the needles between the L61st and R61st needles to position B and push the L36th, L12th, R13th and R37th needles back to position A.

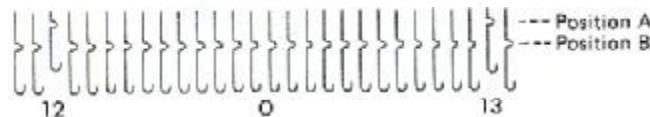

- ② Knit about 10 rows of plain knitting with waste yarn on T.D. 3.
 ③ Knit one row with the CAST-ON THREAD.
 ④ Bring forward all the needles from position B to position E.
 ⑤ Cast-on with the main yarn by using the LATCH TOOL.
 (Make stitches, leaving needles at position L36th, L12th, R13th and R37th empty.)
 ⑥ Knit one row in plain knitting on T.D. 3.
 ⑦ Set the punch card and move the K carriage to select the needles.
 1) The card lock lever must remain at the "●" mark.
 2) Push the left PART button.
 ⑧ Knit 20 rows in skip-stitch pattern.
 ⑨ Change the yarn to a different colour in yarn feeder "A" and knit 2 rows.
 ⑩ Rethread the main yarn into yarn feeder "A" and knit 60 rows in skip-stitch pattern.
 ⑪ Knit 2 rows with a contrast colour yarn.
 ⑫ Knit 20 rows of skip-stitch pattern with the main yarn.
 ⑬ Crease the pleats with a steam iron and measure them.

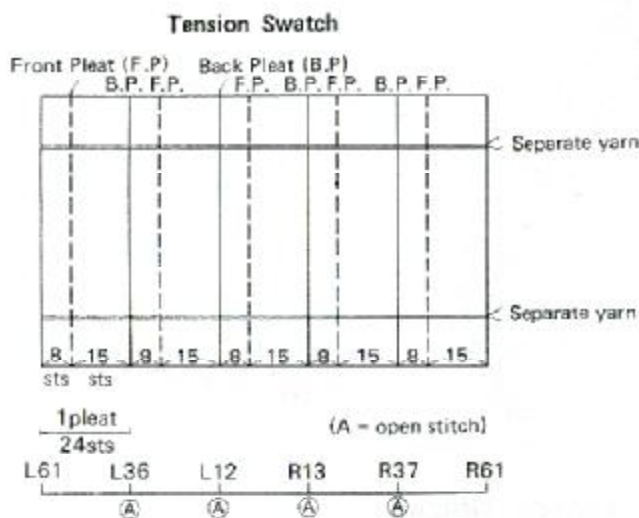

How to determine the knitting gauge

- ① **ROWS.** (Length of the knitting)
 1) Measure the length of 60 rows (inside the two lines knitted with a different colour yarn).
 2) Set the knit-leader regulator for cm and mm.

- ② **STITCHES.** (Width of the knitting)
 1) Measure the width of the pleats (between two front pleats).
 2) Calculate your own size.

Ex.
$$\frac{96 \text{ cm}}{\div 2.3 \text{ cm}} = 41.7 \text{ (42 pleats)}$$
 (Hip size) (width of one pleat) (the number of pleats required for the skirt)

* If your hip size is 96 cm, 42 pleats are necessary to make your own skirt.

** Only 7 pleats can be made in the width of 200 needles, therefore, 6 pieces of the same are necessary for the skirt.

$$\frac{42 \text{ pleats}}{\div 7 \text{ pleats}} = 6 \text{ pieces}$$
 (the number of pleats required for the skirt) (number of pleats in one piece) (the number of pieces required for the skirt)

How to make a pleated skirt

- ① Bring forward all the needles between the L86th and R86th needles to position B.
- ② Push the following needles back to position A as shown in the following diagram. (L60st, L36th, L12th, R13th, R37th and R61st)

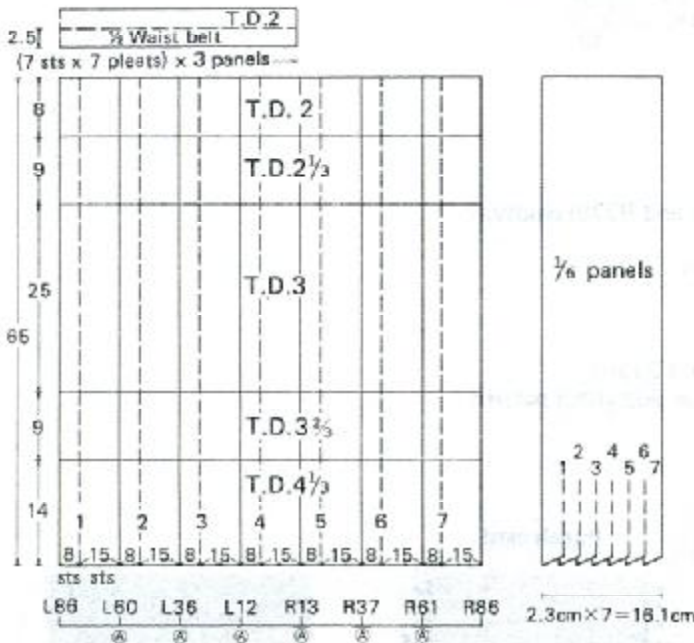

- ③ Knit 21 rows with waste yarn in plain knitting on T.D. 3.
- ④ Knit one row with the CAST-ON THREAD.
- ⑤ Bring forward all the needles from B position to position E.
- ⑥ Cast-on with the main yarn by using the LATCH TOOL.
(Make stitches missing the needles at A position.)
- ⑦ Knit one row on T.D. 3 2/3 in plain knitting.
- ⑧ Set the punch card and move the K carriage to select the needles.
 - 1) The card lock lever must remain at the "●" mark.
 - 2) Push the left PART button.
- ⑨ Knit the length of the skirt in skip-stitch pattern.
(While knitting, adjust the tension dial at the indication lines.)
- ⑩ Knit the last 2 rows with the main yarn on T.D. 2 and one row with the CAST-ON THREAD.
- ⑪ Knit 20 rows of plain knitting with waste yarn on T.D. 3.
- ⑫ Crease the pleats and press the seams with a steam iron.
- ⑬ Knit the waist band.
 - 1) Pick up the stitches as shown in the diagram.



- 2) Knit the number of rows required for double the length of the waist band in plain knitting, and bind off all the stitches.
- ⑭ Fold the waist band with elastic band inside and pin it.
- ⑮ Seam the waist band and give it a final ironing.

13 Shadow Knitting



Shadow knitting is the combination of thick yarn and fine yarn in plain knitting.

A) Shadow pleats

Knit the pleats horizontally.

Knit the thick yarn and the fine yarn on the same tension according to the symbol marks.



Knitting symbol

10	—	—	—	—	—	—	—
9	—	—	—	—	—	—	—
8	—	—	—	—	—	—	—
7	—	—	—	—	—	—	—
6	—	—	—	—	—	—	—
5	—	—	—	—	—	—	—
4	—	—	—	—	—	—	—
3	—	—	—	—	—	—	—
2	—	—	—	—	—	—	—
1	—	—	—	—	—	—	—
	1	2					

Very fine yarn (T.D. 6)

Fine yarn (Two fold) (T.D. 6)

B) Frill pattern with shadow knitting

Knit 8 rows with the very fine yarn on tension 4 and knit 2 rows with the fine mohair with the tension dial on 0.2

Right side

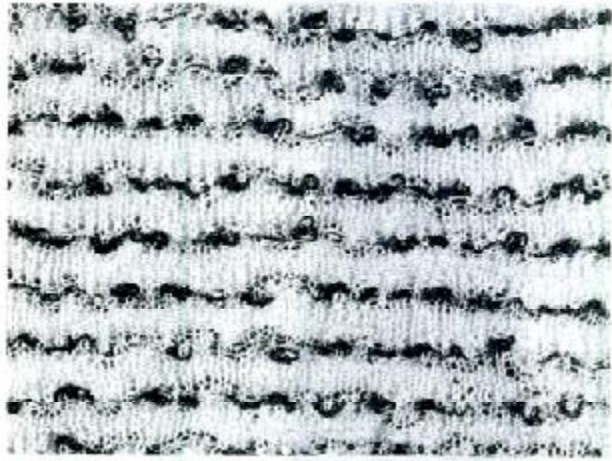

Wrong side

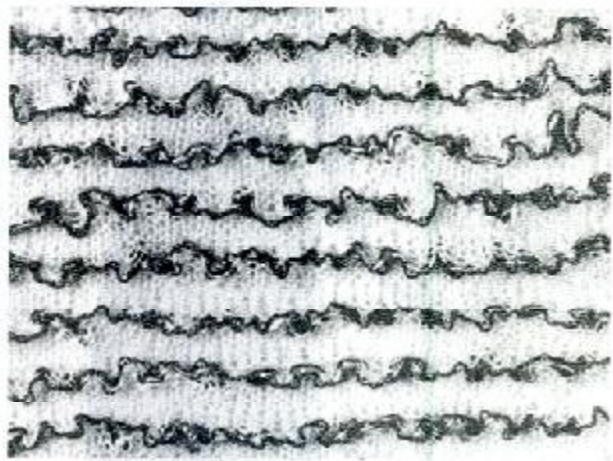

Knitting symbol

10	—	—	—	—	—	} Fine yarn (T.D. 0.2) (Mohair)
9	—	—	—	—	—	
8	—	—	—	—	—	} Very fine yarn (T.D. 4)
7	—	—	—	—	—	
6	—	—	—	—	—	
5	—	—	—	—	—	
4	—	—	—	—	—	
3	—	—	—	—	—	
2	—	—	—	—	—	
1	—	—	—	—	—	
	1	2				



C) Combination of shadow pleats and pull-up stitch

Right side

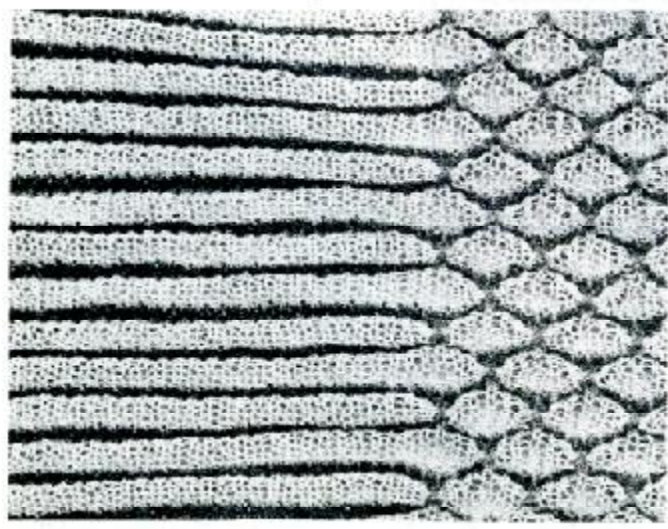

Wrong side

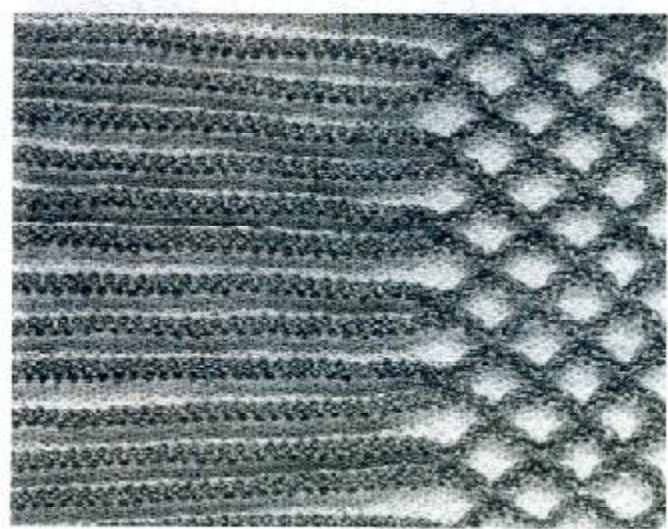

Set the H.C.L. to H (Push button machine to II) and bring forward the needles which will be pulled-up to position 'E'. Knit the pattern according to the symbol marks.

Knitting symbol

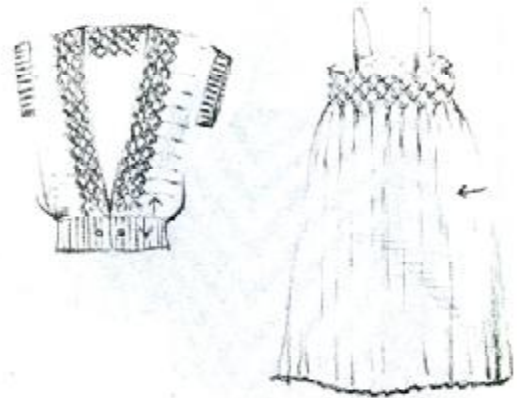
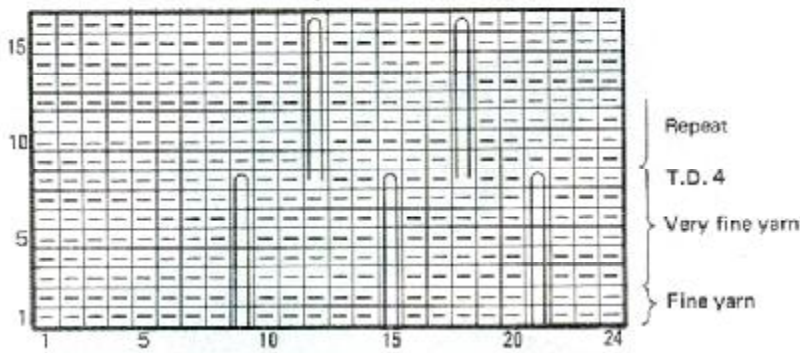

D) Scallop with shadow lace pattern

Knit the scallop according to the symbol marks.

Right side

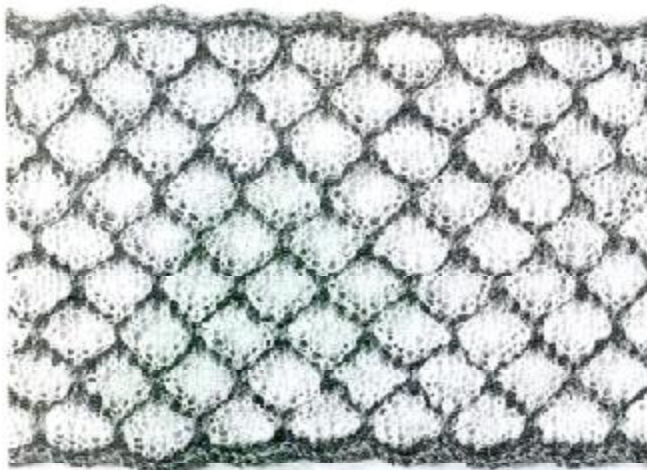

Wrong side

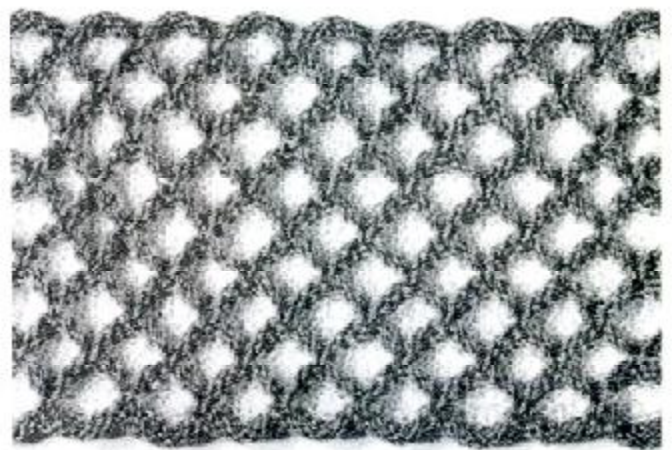

Knitting symbol

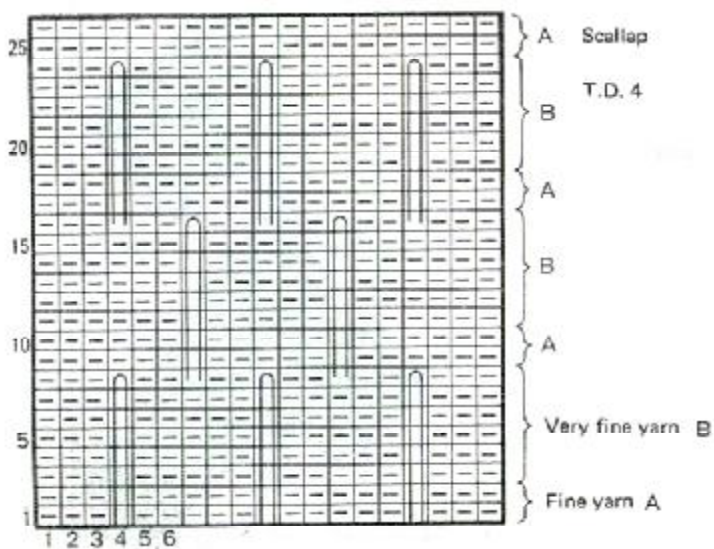

14 Cut and Sew

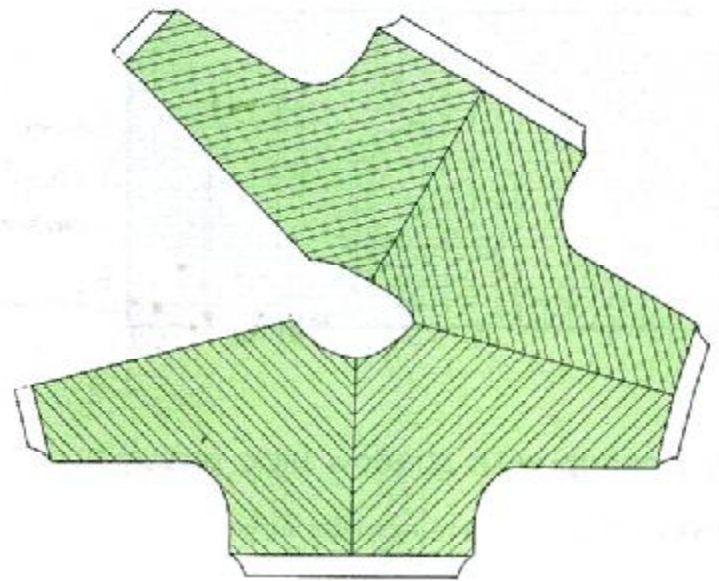

14

It is better to use a very fine or medium yarn for cut and sew.
(It is not recommended to use bulky yarn or a lace pattern swatch for cut and sew).

Example

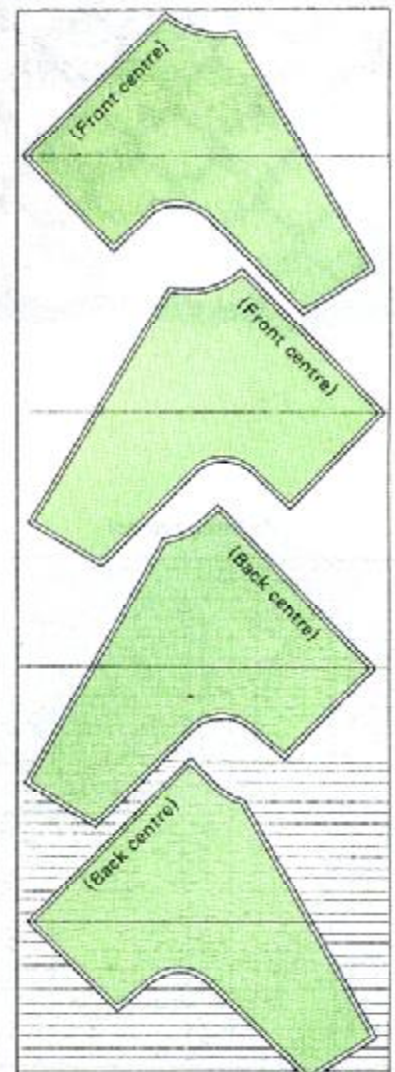





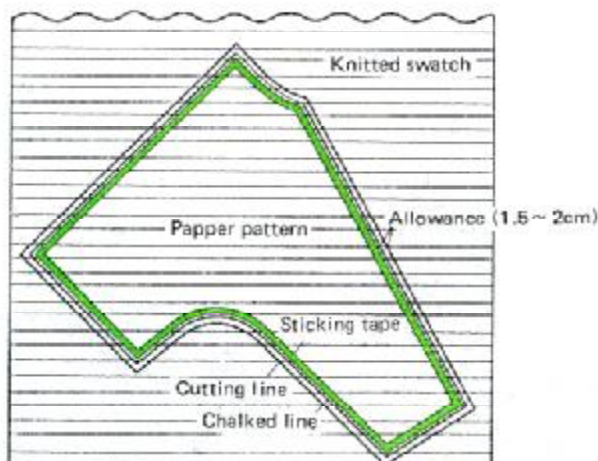





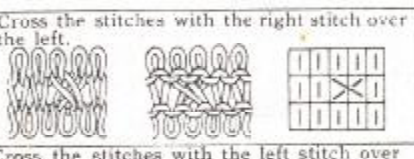



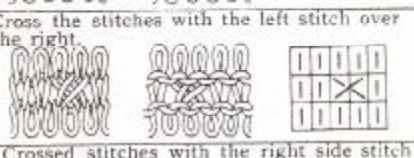



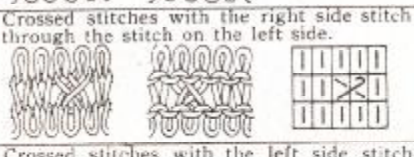

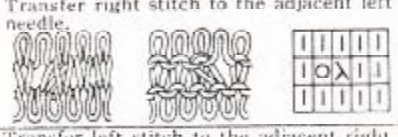

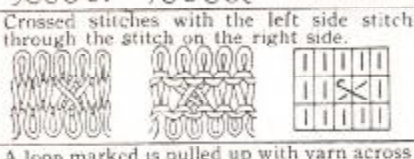



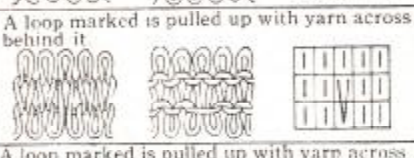



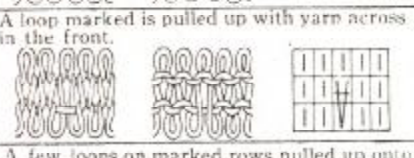





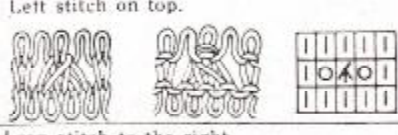

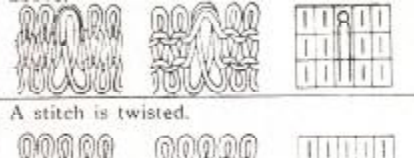

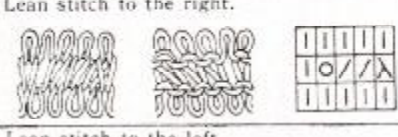

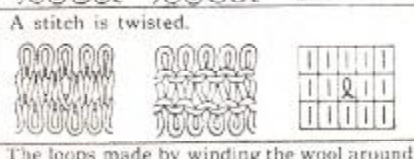

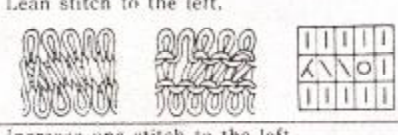
How to cut a knitted swatch.

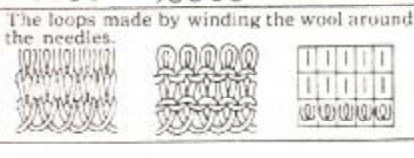
- ① Make a paper pattern according to the actual size and spread it onto the knitted swatch as shown in the diagram.
- ② Pin the edge of paper pattern with blocking pin.
- ③ Chalk out according to the paper pattern as shown in the diagram.
- ④ Stick the sticking tape along the chalk line.
- ⑤ Take 1.5 – 2 cm allowance for the seaming, cut the knitted swatch according to the chalked line as shown in the diagram.
- ⑥ Sew the garment together.

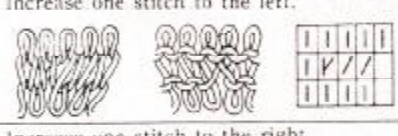

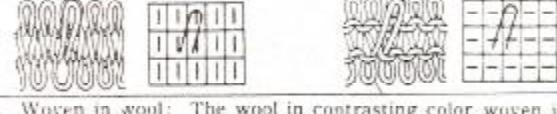
KNITTING SYMBOLS

Symbol & Name	How to Work	Symbol & Name	How to Work
Knit stitch 	Face loop of plain stitch. 	Crossing, right over the left 	Cross the stitches with the right stitch over the left. 
Purl stitch 	Back loop of plain stitch. 	Crossing, right over the right 	Cross the stitches with the left stitch over the right. 
Hole 	Hole made by transferring the stitch to the next needle. 	Cross stitch through left stitch 	Crossed stitches with the right side stitch through the stitch on the left side. 
Two stitches together 	Transfer right stitch to the adjacent left needle. 	Cross stitch through right stitch 	Crossed stitches with the left side stitch through the stitch on the right side. 
Two stitches together 	Transfer left stitch to the adjacent right needle. 	Slip stitch 	A loop marked is pulled up with yarn across behind it. 
Three stitches together 	The center stitch on top of the left and right stitches. 	Float stitch 	A loop marked is pulled up with yarn across in the front. 
Three stitches together 	Right stitch on top. 	Tuck stitch 	A few loops on marked rows pulled up onto one needle. 
Three stitches together 	Left stitch on top. 	Twisted tuck stitch 	A stitch twisted and pulled up onto a needle above. 
Lean stitch to the right 	Lean stitch to the right. 	Twisted stitch 	A stitch is twisted. 
Lean stitch to the left 	Lean stitch to the left. 	Winding stitch 	The loops made by winding the wool around the needles. 
Increased stitch to the right 	Increase one stitch to the left. 	Remarks: 1. As a rule, the symbols are used for the right side of the garment. When it especially calls for the wrong side of the garment, the stockinette etc. are indicated by marks. 2. Diagram of symbols. In order to represent the structure of the pattern as the square sections are usually used having each symbol in the center of the section. 3. Sinker loops. In order to represent the sinker loops the symbols are placed inbetween the sections as shown by the figure No. 4, and the row below it in the figure is to line the row below the mark in the diagram of symbols.	
Increased stitch to the left 	Increase one stitch to the right. 		
Three stitch increase 	The loops made by winding the wool around the needles. 	4. Woven in wool: The wool in contrasting color woven in the garment is indicated like the figures No. 2.	