

# stitchin' time

No.37 60p







# broadly speaking

Here we are again blossoming into a new year, with spring bulbs brightening our days and exciting new things happening in knitting to add even more colour to knitwear. I'm talking about the new KH830 — have you seen it yet? If not just fill in the coupon on the back cover or drop us a line if you don't want to cut-up your magazine and we will send a colour leaflet. Apart from the lace, fairisle, and weaving you have come to associate with Jones machines the KH830 will now produce fine lace and double length patterns. Add a colour changer and you can work four colours, add a ribber and a colour changer and you have eliminated all these loops on fairisle and add a knitleader and you have the most versatile knitting system available and THE BEST.

Although Spring's with us, there's still a nip in the air so we have included some garments in this issue to keep those chill winds at bay. There is also an extremely attractive collection of Aran style garments which we know are going to be great winners with readers, and finally some nice lacy baby garments. So all in all another good selection of garments for everyone.

Don't forget we want to hear from you as often as you like to write. Any hints, tips, suggestions of garments, styles, wool etc. just drop us a line and we will consider them at our Editorial meetings. Happy knitting.

## contents

Men's fairisle sweaters	3-5
Circular shawl	6-7
2 piece suit	7-9
Baby's dungarees	10-11
Men's Waistcoats	12, 25-26
.....	
Aran Style garments:	
Man's roll neck jumper	15-16
Man's bomber jacket	16-17
Lady's jacket	17-18
Girl's raglan jumper	19-20
Tots jumper	20-21
Girl's pinafore dress	22-23
.....	
Ladies' ponchos	27-28
Woven bathroom set	29
Fairisle tunic top	30-31
Fitted bunk bed cover	32
Babies' lacy dresses	33-35

N.B. CHARTS SUBMITTED BY DESIGNERS VARY DEPENDING ON WHICH MACHINE THE DESIGNER HAS USED. MOST PATTERNS USING EIGHT BUTTONS CAN BE DONE ON EITHER THE 588 OR THE 585. THE DIFFERENCES ARE

588	585
REVERSE LEVER+	REVERSE DIAL A
REVERSE LEVER-	REVERSE DIAL B

**SUBSCRIPTION RATES FOR U.S.A. AND CANADIAN MEMBERS \$7.00.**

Printed by McCarthy's (Colour Printers) Ltd., London, E2





# mens fairisle sweaters



## Materials both styles

Robin Vogue 4 ply. 16 (18,20,22) balls Col A. 3 (3,4,4) Balls Col B.

## Measurements

To fit 38 (40,42,44) inch chest. 97 (102,107,112) cms. chest.

Length from back neck. 24½ (25½, 26½, 27½) ins. 62 (65,67.5,70) cms.

Sleeve seam 18½ (19,19½,20) ins. 47 (48.5,49.5,51) cms.

## Tensions

St.st. 7½ sts x 10½ rows = 1 inch, patt. 8 sts. x 9½ rows = 1 inch. T.D. approx 7.

St.st. 14 sts x 21 rows = 5 cms, patt 16 sts x 19 rows = 5 cms. T.D. approx 8.

## 820 M/cs.

Punch card pattern set Vol 2. Style A Card No. 208. Style B Card No. 206.

## 800 M/cs.

Style A. Patt No. 501 from book. Style B from chart.

x				x	x					x	x	20
x				x	x					x	x	19
			x	x	x						x	18
			x	x	x						x	17
		x	x	x	x							16
		x	x	x	x							15
	x	x	x	x	x	x						14
	x	x	x	x	x	x						13
x	x	x	x	x	x	x	x					12
x	x	x	x	x	x	x	x					11
	x	x	x	x	x	x						10
	x	x	x	x	x	x						9
		x	x	x	x							8
		x	x	x	x							7
			x	x	x						x	6
			x	x	x						x	5
x			x	x						x	x	4
x			x	x						x	x	3
x	x			x						x	x	2
x	x			x						x	x	1
1	2	3	4	5	6	7	8	9	10	11	12	

K.H. 800 MACHINE

STEPS

## 588 M/cs.

Style A. from chart. Style B. Patt No. 117 from book.

16				X	X			X
15	X		X	X				X
14	X		X					X
13	X		X	X	X			X
12		X			X	X		
11						X		
10					X			
9	X	X	X	X	X			X
8				X				X
7				X				X
6			X					X
5			X					X
4		X						X
3		X						X
2	X		X			X		X
1				X	X			
STEPS	1	2	3	4	5	6	7	8

**K.H. 588 MACHINE**

**Note**  
Back and sleeves knitted in st.st.  
Fronts knitted in fairisle patt.

### BACK (both styles)

**Step 1. Ribbers** In Col. A. cast on 149 (157,165,173) sts for 1 x 1 rib. TO/O. K 3 rows tub. T 2/2. K 29 rows. Trans needles to main bed \*T7. K 1 row. C.O.R. 000.

**S/Bed.** In Col. A. C.O.B.H. 149 (157,165,173) sts. for 1 x 1 mock rib. T5. Knit 32 rows. T7. K 1 row, T5. Knit 32 rows. Turn hem \*T7. Knit 1 row. C.O.R. 000.

**Step 2.** Knit 130 (136,142,148) rws. Cast off 6 (7,8,9) sts. at beg. of next 2 rows. 000.

**Step 3.** Dec 1 st. at both ends of every alt row 14 (15,16,17) times to 109 (113,117,121) sts. Knit to row 90 (96,100,106).

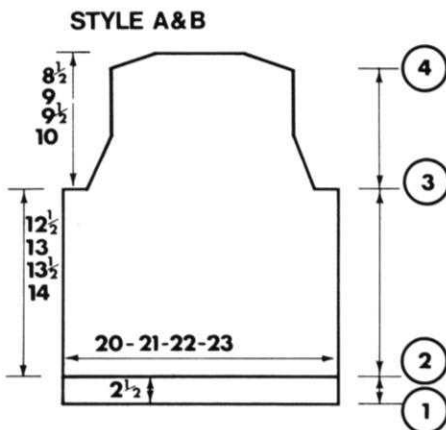

**Step 4. H.P.** Push 6 sts. into H.P. at the end of the next 10 (8,6,4) rows. then 7 sts at end of the next 0 (2,4,6) rows. Thread up rem. 49 (51,53,55) sts.

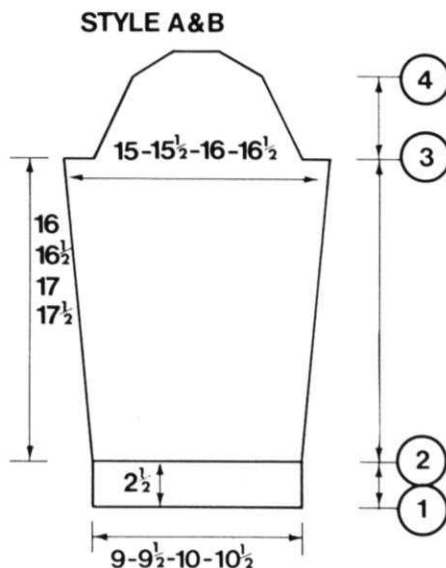

### SLEEVES (both styles)

**Step 1. Ribbers.** In Col. A. cast on 67 (71,75,79) sts. Knit as for step 1 of back.

**S/bed.** In Col. A. C.O.B.H. 57 (71,75,79) sts. Knit as for step 1 of back.

**Step 2.** Inc. 1 st at both ends of every 7th row 23 times to 113 (117,121,125) sts. Knit to row 168 (174,178,184) lengthen or shorten here. Cast off 6 (7,8,9) sts. at beg of next 2 rows. 000.

**Step 3.** Dec 1 st at both ends of every alt row 9 (7,5,3) times then every 3rd row 14 (16,18,20) times to 55 (57,59,61) sts. Dec 1 st. at

both ends every row 0 (1,2,3) times.

**Step 4. H.P.** Push 4 ns. to H.P. at the end of the next 8 rows. Ret. ns to D pos at opp. end of next 2 rows. Cast off.

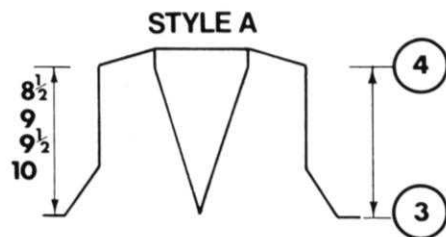

### FRONT STYLE A (V Neck)

**Step 1. Ribbers.** In Col. A. cast on 159 (167,175,183) knit as for Step 1 of back to \* Set m/c for patt. K 1 row. C.O.R. 000. (K rest of front in patt.)

**S/Bed.** C.O.B.H. 159 (167,175,183) sts. Knit as for Step 1 of back to \* Set m/c for patt. T7. Knit 1 row. C.O.R. 000 (K rest of front in patt.).

**Step 2. T8.** Knit to row 118 (124,128,134). Cast off 7 (8,9,10) sts. at beg. of next 2 rows. \*Dec centre sts. to right. 000. Make note of pattern row.

**Step 3.** Working on right half only shape armhole edge as follows. Dec 1 st. at outside edge every alt row 15 (16,17,18) times at the same time dec 1 st. at neck edge every 4th row 0 (1,2,3) times then every 3rd row 25 (25,25,25) times. Knit to row 83 (89,93,97).

**Step 4. H.P.** Push 6 ns into H.P. at the end of the next and every alt row 3 (2,1,0) times. Then 7 ns 2 (3,4,5) times. Ret. ns. from left half to m/c and knit as for right half reversing all shaping.

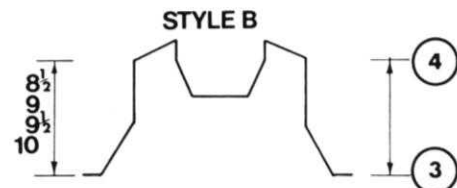

### FRONT STYLE B (Round Neck)

**Step 1.** Knit as for Style A to \* of step 2. 000.



**Step 3.** Dec 1 st. at both ends of every alt row 15 (16,17,18) times 115 (119,123,127) sts. Knit to row

64 (70,74,78). Thread up centre 29 (31,33,35) sts (make note of pattern row). Working on right half only.

Dec 1 st. at neck edge very row 6 times then every alt row 5 times. Knit to row 83 (89,93,97).

**Step 4.** H.P. Knit as for Style A. Ret. ns. from left hand and knit as for right half reversing all shaping. **NECK BAND STYLE A**

**Ribbers.** Cast on 76 (82,86,92) sts. for 1 x 1 rib. T0/0. Knit 3 rows tub. T2/2 inc. 1 st. at right edge very alt row 7 times. Trans ns. to main bed.

**S/Bed.** C.O.B.H. 85 (91,95,101) sts. for 1 x 1 mock rib. T5. Dec. 1 st at right edge every alt row 8 times. T7. Knit 1 row. T5. inc. 1 st. at right edge every alt row 8 times. Turn hem.

With right side of work facing m/c place side neck to these sts. Cast off loosely. Rept for other side of neck

shaping on left side only.

#### **BACK BAND**

**Ribbers.** Cast on 51 (53,55,57) sts. T0/0. Knit 3 rows tub. T2/2. Knit 14 rows. trans ns. to main bed.

**S/Bed.** C.O.B.H. 51 (53,55,57) sts. for 1 x 1 mock rib. T5. Knit 16 rows. T7. K 1 row. T5 knit 16 rows. Turn hem.

With right side of work facing m/c starting 1 st. in from each end place sts. from back onto these sts. and cast off loosely.

#### **TO MAKE UP**

Press all pieces. Join shoulder seams and neck band seams. Set in sleeves. Join rem seams. Give final press.

#### **NECK BAND STYLE B**

Join one shoulder seam.

**Ribbers.** Cast on 139 (143,147,151) sts. for 1 x 1 rib T0/0. Knit 3 rows tub. T2/2. Knit 14 rows, trans ns. to main bed.

**S/Bed.** C.O.B.H. 139 (143,147,151) sts. for 1 x 1 mock rib. T5. Knit 16 rows. T7. K 1 row. T5. K 16 rows. Turn hem.

With right side of work facing m/c and starting 1 st. in from each end place neck edge to these sts. Cast off loosely.

#### **TO MAKE UP**

As for Style A.







## circular shawl

### Materials

Argyll Ferntex. 1 cone col.A, 1 cone col.B.

### Measurements

Diam. 43 ins. 109 cms.

### Tensions

7 sts x 10½ rows = 1 inch, 14 sts x 21 rows - 5 cms.

T.D. approx 7.

### CIRCULAR SHAWL

T7 With waste yarn cast on 140 sts. Knit 20 rows waste. Change Col.A \*\*C.O.R. K 1 row. \*Push 5 needles at right end into H.P. K 2 rows\* rept from \* to \* to end of row (28 times). C.O.L. ret all needles to knit pos. K 1 row.\*\*

Change to Col.B. Knit from \*\* to \*\*.

Continue knitting sequence until 26 sections have been knitted, 13 Col.A, 13 Col.B. Knit a few rows with waste yarn. Remove from M/C.

### TO MAKE UP

Graft edges together, remove waste yarn. Tidy up centre. Press.

### EDGING

T7. Cast on over 13 sts, extra st. on right, having 3rd, 5th, 6th, 8th, 9th, 11th, needles in N.W.P.

820 & 800 M/c's follow chart.

588 M/c \* Push 4th to 10th ns into H.P. H.C.L.III. Knit 4 rows.

H.C.K.I. K 2 rows \* report from \* to \*

T7. Knit from graph until long enough to go around outer edge, fold in half and sew round edge.







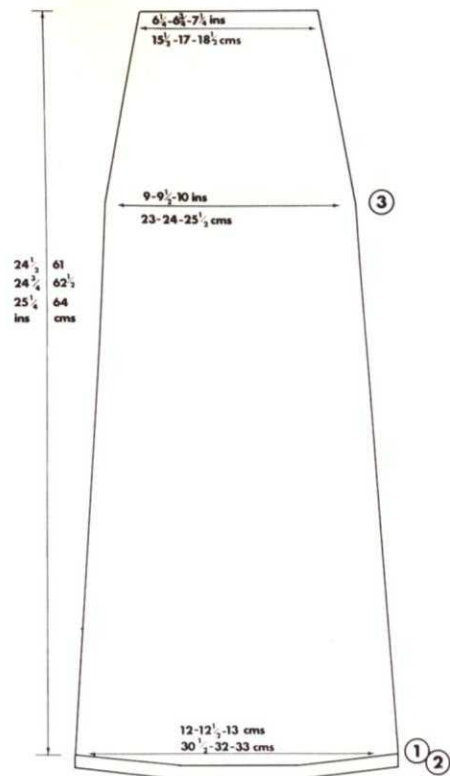

**Waistband** back C.O.B.H. 108 (116 124) sts T4 K14 rows T6 k1 row T4 k14 rows. Turn hem. Starting from left edge place sts from two back panels onto these sts. leaving 8 sts at right empty. Cast off over all sts. Front. Rept. as for back placing panels onto these sts. leaving 8 sts. at left. Join rem. seams leaving a 6 inch opening for zip sew in zip, insert petersham, sew on hook and eyes.

#### TOP

#### Back

**Step 1.** C.O.B.H. 141 (149 157) sts. Knit as for step 1 of skirt to \*H.P. Push 10 sts into H.P. at the end of the next 8 rows. ret. all nds to B pos.000.

**Step 2.** Dec. 1 st at both ends of every 10th row 8 times at the same time K patt. as follows. K8 rows. Trans every alt. nds to right. K4 rows K26 rows of patt. K2 rows. Trans. every alt. sts to right. K4 rows. K26 rows of patt. K to row 94. 125 (133 141) sts. **Holes for belt.** Starting from left edge trans



2 & 4 (6 & 7, 3 & 5)th sts to right.  
\* miss 5 nds trans 6 & 8th sts to right rept. from \* to end. K to row 102.000.

**Step 3.** Inc. 1st at both ends of the every 22 (24 26)th row 4 times to 133 (141 149) sts k to row 74 (80 86). Cast off 4 sts. at beg of next 2 rows.000.

**Step 4.** Dec 1st at both ends of every row 2 times. Dec. 1st at both ends of every alt. row 4(5 6) times. 113 (119 125) sts k 10 rows. Inc. 1st at both ends next and every 8th row 6 times to 125 (131 137) sts. k to row 64 (68 74).

**Step 5.** Cast off 3 sts at beg of next 8 rows. Cast off 4 sts at beg of next 4 (2 2) rows. Cast off 5 sts at beg of next 8 (8 4) rows. Cast off 6 sts at beg. of next 0 (2 6) rows. cont. on rem. 47 (49 51) sts. Trans every alt. sts to right K1 row. Mark end sts. with waste yarn. T4 knit 12 rows. T6 K1 row. Trans. every alt. sts to right. T4 k12 rows. Turn hem picking up loops from marked row. Cast off.

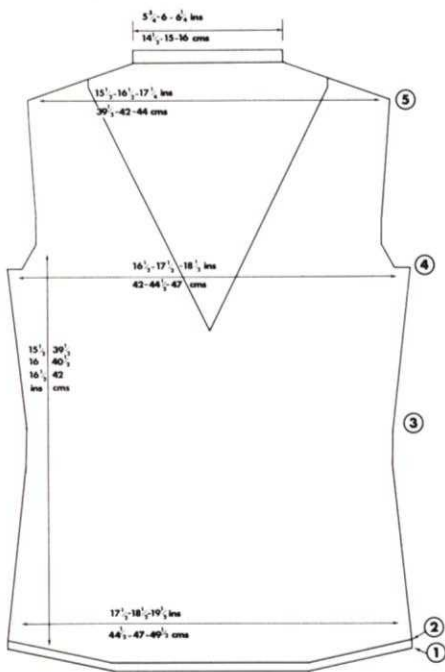

## FRONT

Knit as for back to row 40 (46 52) of step 3. Trans. centre sts. to right working on right half only continue shaping as for back on right edge

only at the same time shape neck edge as follows. Dec. 1 st. at left edge every alt. row 15 (14 11) times. Dec. 1 st at neck edge every 3rd row 27 (29 33) times. Knit to end of step 4. 20 (22 24) sts. Cast off 3 sts at beg of next and every alt. row 4 times. Cast off 4 sts at beg. of next and every alt. row 2 (1 0) times. Cast of 6 st at beg. of next and every alt. row 0 (1 2) times. Ret. sts from left rept. as for right half rev. all shaping.

## Neck lace insert

**Step 1.** Starting on 3rd to left of centre 0 C.O.B.H. 61 (65 69) sts. T4 dec 1st at left edge every alt. row 6 times. T6 k row trans. every alt. sts to right T4 inc. 1 st at left edge every alt. row 6 times. T5 k 1 row. Trans. every alt. st. to right 000.

**Step 2.** Inc. 1 st at left edge every alt. row at the same time. K4 rows. K 26 rows of lace patt. K2 rows. Trans every alt. st. to right K2 row.

## focus on knitting

### ENFIELD

Here's a North London club that has been flourishing for some years now. Run by Mrs Bolwell, help is given on all knitting problems, guidance on designing and ideas exchanged. The club meets on the last Wednesday of each month and new members wanting to join a nice friendly group will be made very welcome. Contact Mrs Bolwell on 01-804 1924 for full details.

### GLOSSOP KNITTING CLUB

Mrs Pam Bond, 1A Bridgefield, Glossop, Derbyshire SK13 9LL. Tel: Glossop 62506

A new club has recently been started in Glossop and is being jointly run by Mrs Pam Bond and Mrs Marie Bentley (Glossop 62384). Just give either one a ring — they'll be pleased to welcome new members.

### Editor:

We received an extremely interesting letter from Mrs Bond that

77 (81 85) sts. Knit a few rows. with waste yarn. Remove work from m/c and replace with wrong side facing m/c. With right side of work facing m/c place left neck edge to these sts cast off loosely. Rept. for right neck starting 4 sts to right of centre 0 and shaping on right edge. Press all pieces. Join shoulder seams.

## Armbands

C.O.B.H. 99 (107 115) sts. T4 Push 4 nds into H.P. at the end of the next 6 rows. Ret. all nds to B pos. (R.C. 8) T6 k1 row trans every alt. sts to right T4 push 4 nds into H.P. at the end of the next 6 rows. K2 rows ret. all nds to B pos. Turn hem. With right side of work facing m/c place armhole edge to these sts. cast off loosely. Rept. for other armhole. Join all rem. seams. Give final press. Tie belt. C.O.B.H. 4 sts T3 depress right part button, knit till cord measures 60 ins. Thread cord through waist line.

contained a whole list of very useful suggestions as to what she would like included in STITCHIN' TIME. Suggestions relating to wool, patterns, hints, displays are now being seriously considered but we want to hear more from all our readers — so come on. Let's be hearing from you!

### NEWTON AYCLIFFE

Mrs Wade, 92 Kirkston Place, Newton Aycliffe, Darlington, Co. Durham.

Popularity for this club has reached such proportions that the organiser, Mrs Jean Wade, has been forced to double meetings by changing from fortnightly to weekly sessions. They are held in the Recreation Centre at Newton Aycliffe on Tuesday evenings 7pm-9pm. So if you are interested just pop along — we can guarantee that you will not be bored — there's always activities on the go, including displays, demonstrations, guest speakers plus of course all the information you could possibly require about knitting and knitting machines.



# baby's dungarees

## Measurements

To fit 16 (18,20) inch chest.

## Materials

6 x 25g balls, Lee Target Lullaby Fairy Fondants, D.K. Courtelle.

2 x 25g balls, Lee Target Baby Titania D.K. Courtelle and Nylon.

2 buttons. 1 size 8 crochet hook.

## Tension

6½ sts and 10 rows 0 one inch over plain and M.C. knitting.

Pattern card no. 9 on 820 machine from basic set.

Pattern as diagram on 800 machine.

18	X							
17	X							
16		X						X
15		X						X
14			X		X			X
13			X		X			X
12				X		X		
11				X		X		
10			X		X			X
9			X		X			X
8				X		X		
7				X		X		
6			X		X			X
5			X		X			X
4		X						X
3		X						X
2	X							
1	X							
STEPS	1	2	3	4	5	6	7	8

K.H. 588 MACHINE

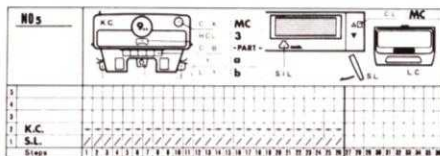
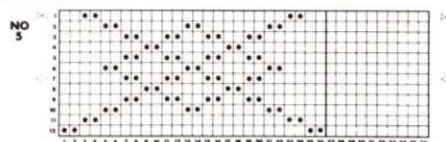

## TROUSERS Knit 2

**Step 1.** Cast on 62 (68, 74) sts by hand in main yarn. Knit 9 rows. Set for pattern. Knit 1 row. (Total 10 rows).

**Step 2.** Knit 24 rows. Change back to main yarn for st.st. Knit to 50 (60,70) rows.

**Step 3.** 000. Inc. 1 st. each side every 3 rows to 18 rows. 74 (80, 86) sts. Knit 2 rows (Total 20 rows).

**Step 4.** Shape crutch. 000. Cast off 4 sts beg next 2 rows. 66 (72,78) sts. Dec. 1 st. each end of every alt row to 8 rows. 60 (66,72) sts. Dec. 1 st. each end of every 14 (15,16) rows to 64 (68, 72) rows. 52(58,64) sts. Knit to 65 (70,75) rows. Place all sts. on st. holder or W.wl.

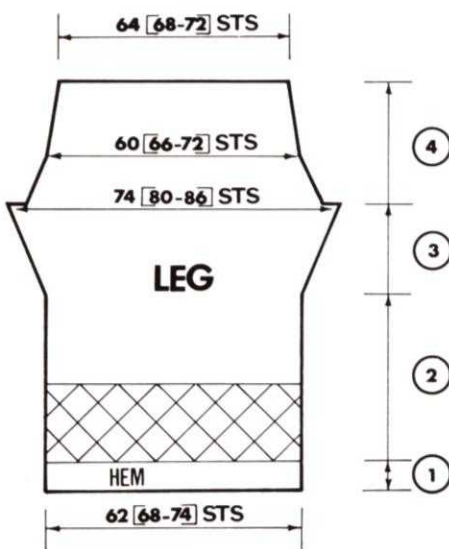

## BACK: Knit one

**Step 1.** Pick up 39 (43,49) sts. from each leg, centre back in centre of machine, in main yarn. Cast on 1 st. extra on each side. 80 (88,100) sts. altogether. Knit 30 (32,34) rows.

**Step 2.** Armholes. 000. Push all but 14 (15,16) Ns on right of

knitting to hold position. Knit 1 row. C.O.L. Cast off 8 sts. on left

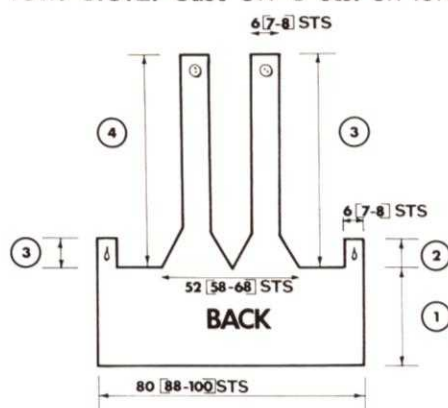

of knitted sts. 6 (7,8) sts. remaining in knit position. Knit 1 row. COR. 2 rows knitted. Knit to 6 rows. Make buttonhole. Push 3 (3,4) sts. to hold position on left edge of sts. being knitted. Knit 8 rows on remaining 3 (4,4) sts. Push these sts. to hold position. Return the 3 (3,4) sts. on left to knit position and knit 8 rows to form buttonhole. Knit 6 row more on all 6 (7,8) sts. 20 rows. Cast off these sts.

**Step 3.** 000. Place carriage on left of machine and repeat step 2 on this side. 52 (58,68) sts.

**Step 4.** 000. Return carriage to right side of machine. Return Ns on right of centre to knit position. On these 26 (29,34) sts. dec 1 st. each side of every other row to 20 (22, 26) rows. 6 (7,8) sts. Knit to 70 (74,80) rows. Cast off.

**Step 5.** Repeat step 4 on remaining sts.

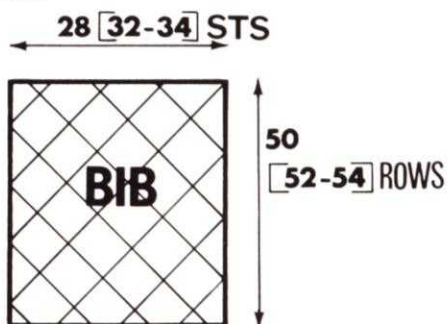

## BIB: Knit one.

In main yarn pick up remaining sts. on front of legs. Centre front in centre of machine. Cast on 1 st. at each end. 28 (32,34) sts. Knit 1



row. Set for M.C. for pattern. Knit 1 row. Knit pattern as hem on ankle to 50 (52,54) rows. Cast off.

**TO MAKE UP:**

**Step 1.** Lightly press all pieces.

**Step 2.** Stitch inside leg seams and

crutch seam. Stitch up hem on ankle, fold at bottom on M.C. knitting.

**Step 3.** Stitch edges of back to edges of bib, these are not side seams, they come on the front of

the garment.

**Step 4.** Work one row of crochet around neck edge, including on both edges of straps.

**Step 5.** Stitch on buttons in appropriate position.

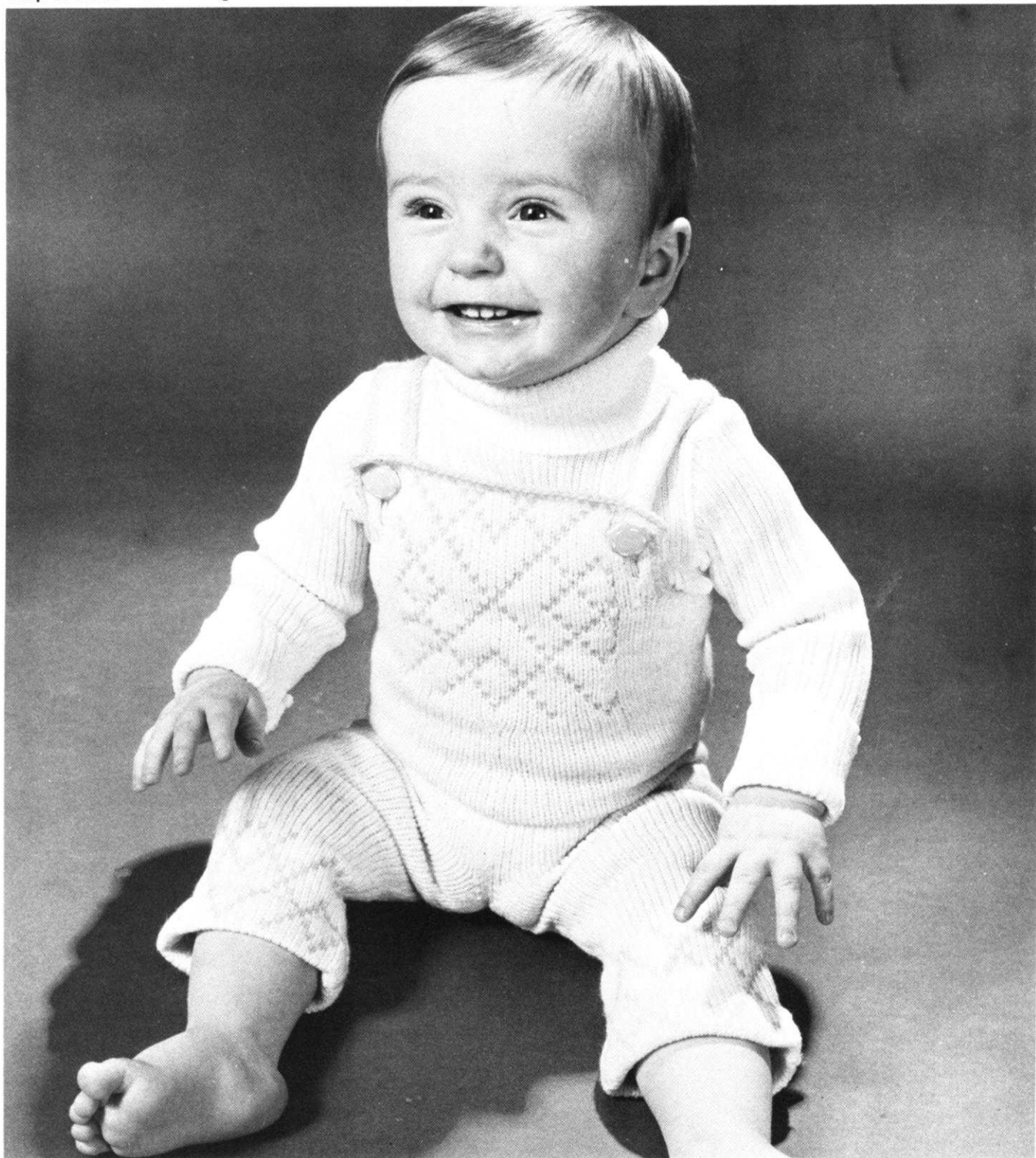



# waistcoats

## THREE MENS WAISTCOATS IN EITHER FAIRISLE, TUCK STITCH OR WOVEN AND CHOICE OF EDGINGS

### Materials

Lister Easy Wash 4 ply crepe

Lister Easy Wash D.K. crepe (woven)

### Fair isle

8 (9,10,11) balls col A

3 (3,4,4) balls col B

### Tuck stitch

11 (12,13,14) balls

### Woven

10 (11,12,13) balls Col A 4 ply

2 (2,3,3) balls Col B D.K.

### Measurements

To fit 36 (38,40,42) inch chest.

To fit 91 (97,102,107) cm chest.

Length from back neck

21½ (22,22½,23) inches 54.5 (56, 57,58.5) cms.

### Tension and Patterns

St. st. 14½ sts. x 22 rows = 2 inch or 5 cms T.D. approx. 7

Fair isle 16 sts. x 19 rows = 2 inch or 5 cms T.D. approx 8

820 patt. no. 56 from book

800 patt. no. 514 from book

588 patt. no. 163 from book

Tuck stitch 13½ sts x 29 rows = 2 inches or 5 cms T.D. approx 7

820 from chart

800 patt. no. 440 from book

588 patt. no. 449 from book

Woven 13½ sts x 22 rows = 2 inches or 5 cms. T.D. approx 7

820 patt. no. 269 from book

800 patt. no. 320 from book

588 patt. no. 959 from book

### BACK (SAME FOR ALL GARMENTS)

Step 1. Ribbers. Cast on 123 (131,

139,147) sts. for 1x1 rib TO/O knit 3 rows Tub. T 4/4 knit 26 rows. Trans. sts. to main bed. 000 S/bed m/c Cast on alt. nds for 1x1 rib 123 (131,139,147) sts. T4 knit 42 rows.

Turn hem. 000.

Step 2. T7 Inc. 1st at both ends every 12 (12, 13, 13)th row 8(8, 7, 7) times to 139 (147, 153, 161) sts. knit to row 100. Cast off 5 (6, 6, 6) sts at beg. of next 2 rows. 000.

Step 3. Cast off 3 (3,3,4) sts. at beg of next 2 rows. Dec 1st. at both ends of every alt. row 5 (6,6,7) times. Dec. 1st at both ends of every 3rd row 5 times. 103 (107, 113,117) sts. Knit to row 106 (110, 116,122).

Step 4. Cast off 6 sts. at beg of next 10 (8,4,2) rows. Cast off 7 sts. at beg. of next 0 (2,6,8) rows. Place

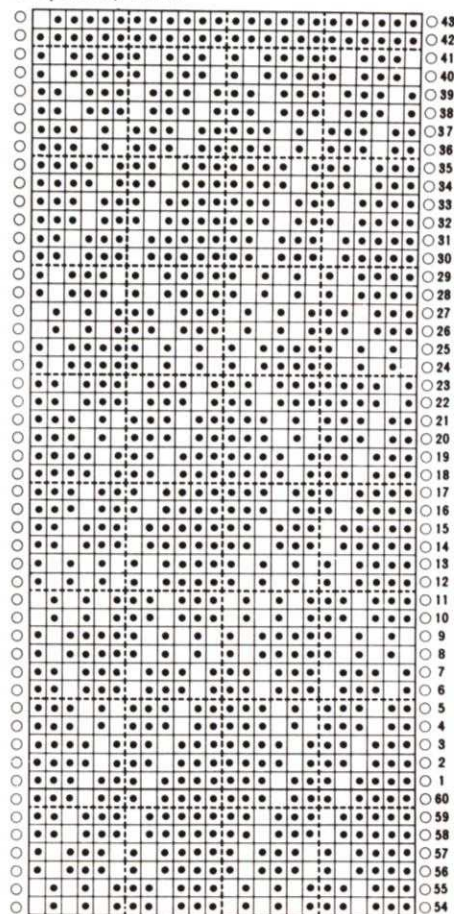



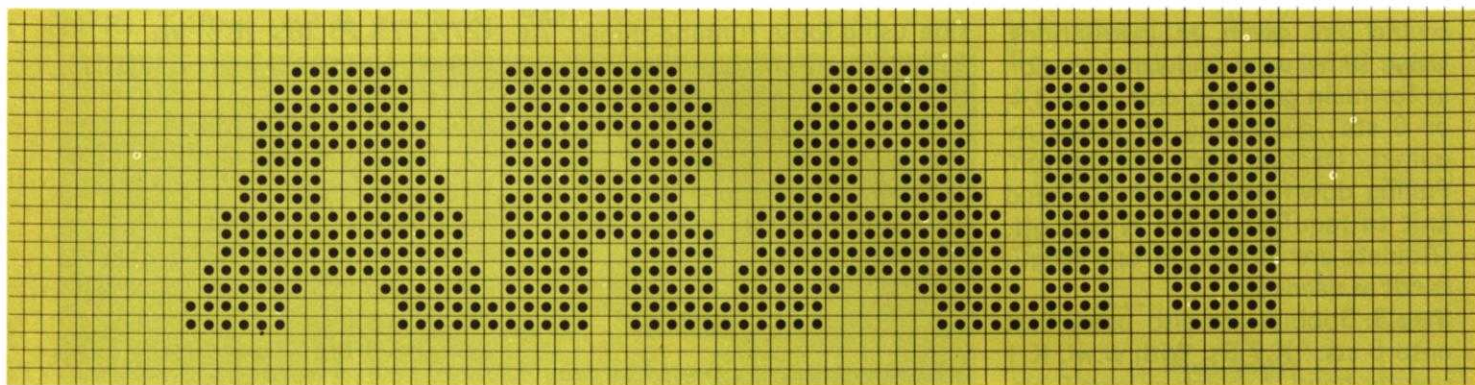

## Aran Style Patterns from Jones



jones + brother **JB**



Aran knitting effects are achieved by using a stocking-stitch pattern and adding the design by applying knitting roulets and bobbles before sewing up the garment.

The main points are as follows.

**Step 1.** Either the plain side or the purl side of the knitting may be used as the 'right' side of the garment.

**Step 2.** Roulets, or tubular, knitting are used to make the patterns and these are made in varying widths to give different effects. In each pattern the number of sts. used for roulets are given in instructions. Using same wool and same tension as for main garment, cast onto 3, 4, or 6 sts., depending on effect required. Depress right part-button. Pulling down roulet with Lt. hand knit to required length & cast off. (Roulets are knitted in one length & cut as needed.)

**Step 3.** Bobbles are also used. Cast onto 6 sts. \*K.7 Rs. With w.wl. K.1 row by hand. Leaving at least 9 ins. of wool hanging at edge for sewing up, repeat from \* for each bobble required. Cut strands left for sewing up. Press strip of knitting to prevent unravelling. Pull out W.wl. thus separating bobbles. Using darning needle thread strand of wool through each st. at top along side, through each st. at bottom and up other side.

Draw up bobble & secure threads. (Do not cut off as they are used for attaching bobbles to garment.)

**Step 4.** The roulets are used to make pattern, e.g. diamond pattern using 2 lengths of roulets and bobbles, open cables using 2 lengths of wider roulets, closed cable, alternate cable & diamond pattern with bobbles, and half cables with bobbles. (as illustrated in photographs)

**Step 5.** Choose the side of knitting to be right side, & decide on the type of trimming to be used. To estimate the amount of roulet required, measure the length of pattern panel & multiply by 3 for

each strip of cable or diamond, or by 1½ for zig-zag or half cable.

Knit the garment pieces, do not sew up. Knit the roulets & bobbles.

Press the garment pieces & pin out to shape onto piece of foam or ironing board. Mark out lines for pattern with pins, using tape-measure for accurate spacing. Pin the roulets in place taking care to cross over the roulets in the correct position to create a balanced pattern, latch down the roulets loosely in place using wool of main garment, this can be done on wrong side using loose running thread. At ends of roulets, thread-up sts. and secure to garment. Pin bobbles in position & using ends of wool secure in place. When all pieces of garments have been decorated, sew up in the usual way.



#### Materials

LISTER/LEE TARGET SUPER-WASH WOOL.

Machine washable double knitting. In 25g balls.

**Style 130. Man's Jumper**  
30 (31,32,34,36,38) balls.

#### Measurements

To fit 34 (36,38,40,42,44) in. chest  
Finished measurements 35 (37, 39, 41, 43, 45) in. chest.

Length from Back Neck 23 (24,25,25¾,26½,27¼) ins.

Sleeve seams 17½ (17½, 18, 18, 18½,18½) ins.

**Style 131. Man's 'Bomber' Jacket**  
28 (30,32,34) balls.

#### Measurements

To fit 34 (36,38,40) in. chest  
Finished measurements 35 (37, 39, 41) ins.

Length from Back Neck 22 (22½,23½,23¾) ins.

Sleeve seams 17½ (17½,18, 18,18½,18½) ins.

#### Style 132. Lady's Jacket

31 (32,33,34,35,36) balls.

#### Measurements

To fit 32 (34,36,38,40,42) ins. bust  
Finished measurements 34 (36,38, 40,42,44) ins.

Length from Back Neck 27¼ (27½,27¾,28,28¼,28½) ins.

Sleeve seams 17 (17,17½,17½, 18,18) ins.

#### Style 133. Girl's or Boys

17 (18,19,20,21) balls.

#### Raglan Jumper

#### Measurements

To fit 28 (30,32,34,36) in. chest  
Finished measurements 29 (31,33, 35,37) ins. chest

Length from Back Neck 19½ (20¼,21,21¾,22½) ins.

Sleeve seams 16½ (16½,17,17,17½) ins.

#### Style 134. Tots Jumper

9 (10,11,12) balls.

#### Measurements

To fit 22 (24,26,28) in. chest  
Finished measurements 23 (25,27,29) ins.

Length from Back Neck 12¾ (14¼,15¾,17¼) ins.

Sleeve seams 10 (11½,13,14½) ins.

#### Style 135. Girl's Pinafore

9 (10,10,11) balls

#### Measurements

To fit 22 (24,26,28) in. chest  
Finished measurements 23 (25,27,29) ins.

Length from Back Neck 19¾ (21,22¼,23½) ins.

#### Tensions 820 M/cs.

7 sts x 9½ rows = 1 inch on T.9. on YF ▲ over st.st.

#### 800 M/cs.

7 sts x 9½ rows = 1 inch on T.8. Y.F. on -

#### 588 M/cs.

7 sts x 9½ rows = 1 inch on T.9. Y.F. +.



# mans jumper I30

## BACK

**Step 1. Ribbers** Cast on 122 (130, 138, 142, 150, 158) sts as 2 x 2 rib. T 7/6. K.2 Rs. Tub. T.8/7. K. 18 Rs. rib. Trans. Ns. to M.B.

**Single-bed M/cs.** With W.wl. Cast onto 122 (128, 128, 137, 143, 152, 158) sts. \*K. a few Rs. Trans. Ev. 3rd st. to Rt. Push empty Ns. back to A pos. Change to M.wl.\* T.8 K. 24 Rs. T.10. K. 1 T.8. K. 24 Rs.

M.D.E. Remove W.wl. T.9. K. 1. Dec. or Inc. to 123 (129, 137, 143, 151, 157) sts. C.O.R. 000

**Step 2.** T.9. K. 100 (116, 122, 128, 134, 140) Rs. straight.

**Step 3.** C/O 8 (8, 9, 9, 10,10) sts. at each edge C.O.R. 000

**Step 4.** Dec. 1 st. on each edge. Ev. 3 Rs. 7 times. K to 22 Rs. C.O.R. 000

**Step 5.** K. 54 (58, 62, 64, 66, 68) Rs. straight. C.O.R. 000

**Step 6.** H.P. \* 6 (6, 7, 7, 8, 8) sts. at opp. end to carr. on next 4 Rs. Then H.P. \* 6 (7,7,8,8,9) sts on next 4 Rs. Return Ns. to D. pos. at opp. end to carr. on next 2 Rs. C/O shoulder. Thread-up back neck sts.

## FRONT

As for back to end of step 4.

**Step 5.** As for back. At the same time after 34 (36,38,40,42,44) Rs. thread-up centre 19 (21,23,25,27,29) sts. & take off H.P. sts on Ltd. Then H.P. 1 st on Rt. neck edge Ev. alt. R. 13 times.

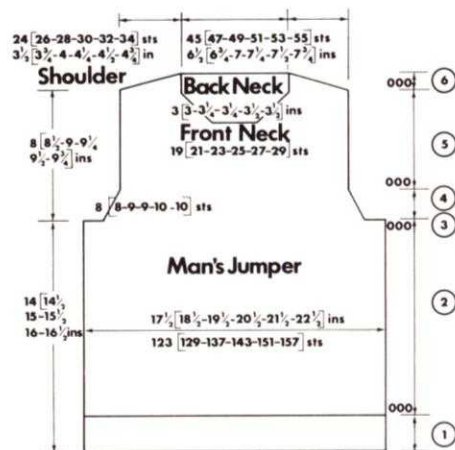
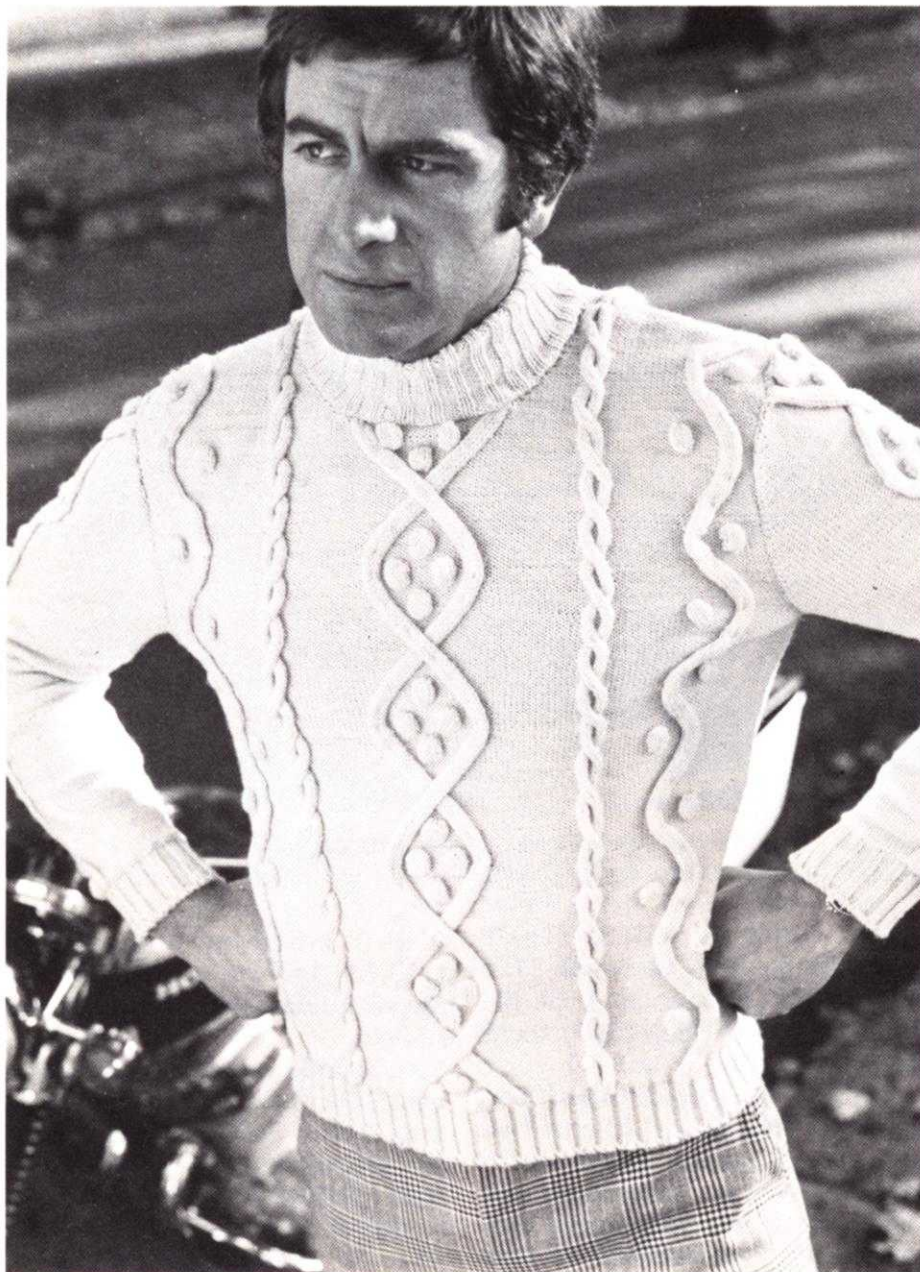

**Step 6. Rt. Shoulder.** At the same time as working neck shaping C.O.L. \* H.P. \* 6 (6,7,7,8,8) sts. at opp. end to carr. Ev. alt. R. 2 times. Then H.P. \* 6 (7,7,8,8,9) sts. Ev. alt. R. 2 times. Return shoulder sts. to D. pos. K.1 C/O \*. Return Ns. on Lt. to D. pos. Shape neck edge as for Rt. After 34 (26,38,40,42,44) Rs. work shoulder.

**Step 6. Lt. shoulder** As for Rt. shoulder from \* to \*. Thread-up neck sts.

## SLEEVES

**Step 1. Ribbers.** Cast onto 54 (58, 62, 66, 70, 74) sts. as 2 x 2 rib. K; as for step 1 of back.

**Single-Bed M/cs.** With W.wl. Cast onto 56 (59, 62, 68, 71, 74) sts. K. as for back. Dec. or Inc. to 55 (59,63,67,71,75) sts. C.O.R. 000

**Step 2.** Inc. 1 st. on each edge Ev. 8



Rs. 17 times. K to 146 (146,150,150,154,154) Rs.

**Step 3.** As for back.

**Step 4.** Dec. 1 st. on each edge Ev. 3 Rs. 15 times. K to 46 Rs. C.O.R. 000

**Step 5.** H.P. 7 (5, 4, 3, 3, 3) sts. at opp. end to carr. on next 2

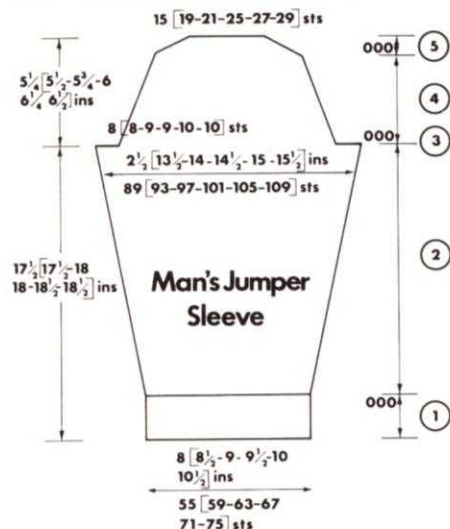

(4,4,8,4,4) Rs. Then 7 (4,3,2,2,2) sts. on next 2 (2,4,2,8,8) Rs. Return Ns. to D. pos. at opp. end to carr. on next 2 Rs. C/O.

### TO MAKE UP

Press all pieces. Join shoulders.

### NECKBAND

**Ribbers.** Cast onto 98 (102, 106, 110, 114, 118) sts as 2 x 2 rib. T.7/6 K. 2 Rs. Tub. T.8/7 K. 62 Rs. rib. Trans. Ns. to M.B.

**Single-Bed M/cs.** With W.wl. cast onto 98 (104, 107, 110, 116, 119) sts. As \* to \* of back, step 1 T.8. K 16 T.10. K 1. T.8. K. 16 M.D.E. Remove W.wl. Inc. or Dec. to 98 (102,106,110,114,118) sts.

With Rt side of work facing M/c, place side neck to 17 sts, place front neck to 19 (21,23,25,27,29) sts. C/O up to this point. Place side neck to 17 sts. Place back neck to 45 (47,49,51,53,55) sts. C/O to end.

Join neckband edges.

Knit roulets 6 sts & 4 sts. wide & apply to front, back & sleeves.

Sew tops of sleeves into armholes. Press seams. Join side & sleeve seams. Press all seam & bands.



## mans bomber jacket 131

### BACK

**Step 1. Ribbers** Cast onto 122 (130, 138, 142) sts. as 1 x1 rib. T.7/6. K. 2 Rs. Tub. T.8/7. K. 18 Rs. rib. Trans. Ns. to M.B.

**Single-Bed M/cs** With w.wl. Cast onto 122 (131, 137, 143) sts. \* K. a few Rs. Tans. Ev. 3rd st. to Rt. Push empty Ns. back to A pos. Change to M.wl.\* T.8 K.24. T.10. K.1. T.8. K.24. M.D.E. Remove

W.wl. T.9. K.1. Inc. or dec. to 123 (129,137,143) sts. C.O.R. 000

**Step 2.** K. 98 (98, 104, 104) Rs. straight.

**Step 3.** C/O. 8(8,9,9) sts. at beg. next 2 Rs. C.O.R. 000

**Step 4.** K. 76 (80,84,86) Rs. straight.

**Step 5.** H.P. 9 (9,10,10) sts. at opp. end to carr. on next 2 (6,2,6) Rs. Then 8 (8,9,9) sts. on next 6



(2,6,2) Rs. Return Ns. to D. pos. at opp. end to carr. on next 2 Rs. C/O shoulders. Thread-up B.N. sts.

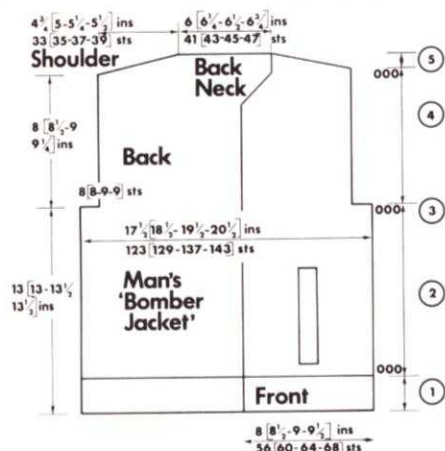

## FRONT

**Step 1. Ribbers** Cast onto 58 (62, 66, 66) sts. K as for back.

**Single-Bed M/cs** With W.wl. Cast onto 59 (62, 65, 67) sts. K. as for back.

**Step 1.** Dec. 1 st. C.O.R. 000. Dec. or inc. to 57 (60,64,67) sts.

**Step 2.** K. 98 (98,104,104) Rs. straight. After 10 Rs. make pocket-opening.

**Pocket-opening** Push 27 Ns. on Lt. to E. Pos. K. 56 Rs. Push all Ns. to E. pos. Return 27 Ns. on Ltd. to D. pos. K. 56 Rs. C.O.R. Return all Ns. to D. pos.

**Step 3.** C/O 8 (8,9,9) sts. on Rt. edge. K. 2 Rs. C.O.R. 000

**Step 4.** K. 76 (80,84,86) Rs. straight. After 56 (60,64,66) Rs. shape front neck. Dec. 1 st. on Lt. edge Ev. R. 16 (17,18,19) times.

**Step 5.** K.1 H.P. \*Push 9 (9, 10, 10) Ns. to E. pos. at opp. end to carr. Ev. alt. R. 1(3,1,3) times. Then 8(8,9,9) Ns. to E. pos. 3(1,3,1) times. Return all Ns. to D. pos. K. 1 C/O.\*

Repeat front, reversing all shapings.

## SLEEVES

As for style 130 Man's jumper.

## TO MAKE UP

Press all pieces.

**Pocket Bands. Ribbers** Cast onto 38 sts. as 2 x 2 rib. T.7/6. K.2 Rs. Tub. T.8/7. K.10 Rs. rib. Trans. Ns. to M.B.

**Single-Bed M/cs.** With W.wl. Cast onto 38 sts. As \* to \* of back step 1 T.8 K.12 T.10. K.1. T.8. K.12. M.D.E. Remove W.wl.

With Rt. side of work facing M/c, & starting 1 st in from edge, place pocket-opening front edge evenly onto Ns. C/O. Repeat.

**Pockets** With Rt. side of work facing M/c, pick up other edge of pocket-opening onto 42 sts. T.9. K.70 Rs. straight. Pick up loops from cast off edge of band (on wrong side), & place onto 40 sts. of pocket. K.1 C/O. Repeat. S1. st. edges of pocket bands onto fronts. Pull out pocket to right side & sl. st. edges together (so that seam is on inside of front).

**Front Bands: Ribbers** Cast onto 19 sts. as 1 x 1 rib. T.5/4 Sl. 1 on 2 K.2 Rs. Tub. T.7/6.

K. 157 (161,167,169) Rs. rib. Trans. Ns. to M.B. C/O. Pin band in pos. up right front & sl. st. in place. **Single-Bed M/cs.** With W.wl. Cast onto 114 (118, 126, 130) sts. As \* to \* of back, step 1. T.8. K.14. T.10. K.1. T.8. K.14. M.D.E. Remove W.wl.

With right side of work facing M/c, place front edge of right front evenly onto sts. & C/O to end.

**Button-hole Band: Ribbers.** As before. After 3 (3,4,5) Rs. \* Push 10 Ns. on Lt. to E. pos. H.P. K.11 Rs. Push all Ns. to E. pos. C.O.R. Return 10 Ns. on Ltd. to D. pos. Pull loop of Y down between groups of Ns. K. 24 (24,26,26) Rs\*. Repeat from \* to \* making 5 holes in all & ending with 3 (3,4,5) Rs. Trans Ns. to M.B. C/O. Attach as before to left front. Finish holes.

**Single-bed M/cs.** As before, after 7 & 22 Rs. make holes. Starting the 3rd st. in from each edge & using W.wl. K. next 6 sts by hand (include Ns. in A. pos.) Leave 20 (21,23,24) sts. between holes, making 5 holes in all. C/O band as before. Finish holes.

Join shoulders.

Knit roulets 6 sts. & 4 sts wide & apply to fronts, back & sleeves. Sew

tops of sleeves into armholes. Press seams of armholes, pockets & front-bands.

Join side & sleeve seams.

**Collar: Ribbers.** Cast onto 94 (98,102,106) sts. as 2 x 2 rib. T.7/6. K. 2 Rs. Tub. T.8/7. K.46 Rs. rib. Trans. Ns. to M.B.

**Single-Bed M/cs.** With W.wl. Cast onto 95 (98, 101, 104) sts. As \* to \* of back, step. 1. T.8. K.52 T.10. K.1 T.8. K.52 M.D.E. Unravel W.wl. Dec. to 94 (98,102,106) sts. With wrong side facing m/c, place side neck to 26 (27,28,29) sts. B.N. to 41 (43,45,47) sts., & side neck to Rem. sts. C/O to end.

Close edges of collar. Press all seams, bands & collar. Sew on buttons.

# lady's jacket 132

## BACK

**Step 1.** C.O.B.H. 124 (132, 140, 148, 156, 164) sts. \*T.8. K.10 T.10. K.1 T.8. K.10 M.D.E. T.9. K.1 C.O.R. 000\*

**Step 2.** Dec. 1 st on each edge. Ev. 26 Rs. 4 times. K to 104 Rs. C.O.R. 000

**Step 3.** K.56 Rs. straight.

**Step 4.** C/O 6 (7,8,9,10,11) sts. at beg. next 2 Rs. C.O.R. 000

**Step 5.** K.78 (80,82,84,86,88) Rs. straight. C.O.R. 000

**Step 6.** H.P. \*7 (7,8,8,9,9) sts. at opp. end to carr. on next 2 (6,2,6,2,6) Rs. Then 6 (6,7,7,8,8) sts. on next 6 (2,6,2,6,2) Rs. Return Ns. to D. pos. on next 2 Rs. C/O shoulders. Thread-up B.N. sts.

## RIGHT FRONT

**Step 1.** C.O.B.H. 57 (61, 65, 69, 73, 77) sts. Hem as for back from \* to \*.

**Step 2.** Shape as for back on Rt. edge only.



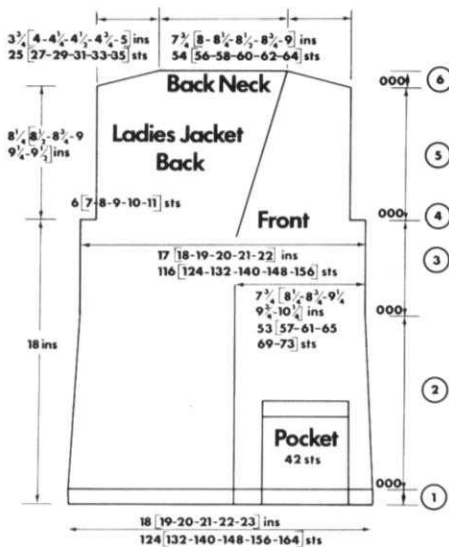

**Step 3.** K.56 Rs. After 50 (48,46,46,44,42) Rs. shape front neck. Mark edge st. on Lt. with W.wl. Dec. 1 st. on Lt., then dec. 1 st. Ev. 4 Rs. 21 (22,23,24,25,26) times.

**Step 4.** C/O 6 (7,8,9,10,11) sts. on Rt. edge K.2 Rs. C.O.R. 000

**Step 5.** As for back shaping on neck edge.

**Step 6.** K.1 \*H.P.\* 7 (7,8,8,9) sts. at opp. end to carr. Ev. alt. R.1 (3,1,3,1,3) times. Then 6 (6,7,7,8,8) sts. 3 (1,3,1,3,1) times. Return Ns. to D. pos. K.1 C/O shoulder.\*

#### LEFT FRONT

**Step 1.** As for Rt. front.

**Step 2.** Shape as for back on Lt. edge only.

**Step 3.** As for Rt. front shaping on Rt. edge only.

**Step 4.** K.1 C/O 6 (7,8,9,10,11) sts. on Lt. K.1 C.O.R. 000

**Step 5.** As for back.

**Step 6.** As for Rt front from \* to \*.

#### SLEEVES

**Step 1.** Ribbers Cast onto 62 (66, 70, 74, 78, 82) sts. as 2 x 2 rib. T.7/6. K 2 Rs. Tub. T.8/7. K.26 Rs. rib. Trans. Ns. to M.B.

**Single-Bed M/cs.** With W.wl. Cast onto 62 (65, 71, 74, 77, 83) sts. \*K a few Rs. Trans Ev. 3rd st. to Rt. Push empty Ns. back to A. pos. Change to M.wl.\* T.8. K.30 T.10. K.1 T.8. K.30. M.D.E. Remove

W.wl. T.9 K.1 Inc. or dec. to 62 (66,70,74,78,82) sts. C.O.R. 000

**Step 2.** Inc. 1 st. on each edge Ev. 14 (13,12,11,11,10) Rs. 9 (10,11,12,13,14) times. K. to 132 (132,138,138,144,144) Rs.

**Step 3.** As for Back.

**Step 4.** Dec. 1 st. on each edge Ev.

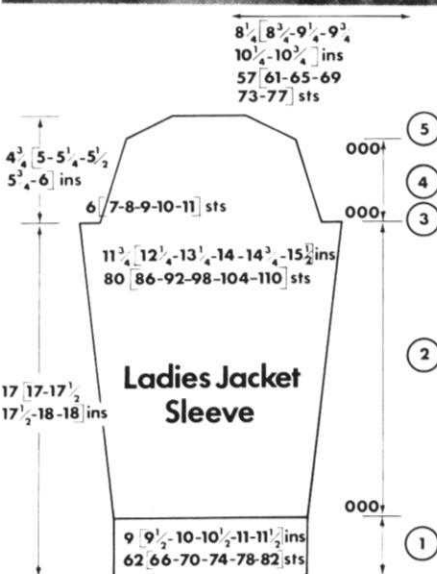

4 Rs. 9 (9,10,10,11) times. K to 36 (38,40,42,44,46) Rs. C.O.R. 000

**Step 5.** H.P. \* 4 (3,3,2,2,2) sts. at opp. end to carr. on next 4 (6,4,6,4,8) Rs. Then 4 (3,2,2,1,1) sts. on next 2 (2,6,6,10,8) Rs. Return Ns. to D. pos. on next 2 Rs. C/O.

**Pockets: Ribbers** Cast onto 42 sts T.7/6. K.2 Rs. Tub. T.8/7. K.8 Rs. rib. Trans. Ns. to M.B.

**Single-Bed M/cs.** With W.wl. Cast onto 41 sts. As \* to \* of sleeves, step 1. T.8. K.10 T.10. K.1 T.8. K.10 M.D.E. Remove W.wl. T.9 K.52 Rs. C/O.

#### TO MAKE UP

Press all pieces. Join shoulders.

Knit roulets 6 sts. & 4 sts. wide & apply to pockets. Sl. st. pockets to fronts  $1\frac{1}{2}$  ins. in from front edges & above hem. Apply roulets to fronts, finishing inside pocket ribs. Apply roulets to sleeves & back. Step tops of sleeve into armholes. Press all seams & roulets.

Join side & sleeve seams.

**Front-band: Ribbers** Cast onto 91 sts as 1 x 1 rib. T.5/4. K.2 Rs. Tub. T.7/6. K.4 Rs. rib.

**Buttonholes:** \* H.P. 10 sts on Lt. K.11 Rs. H.P. all sts. Move carr. to Rt. Pull down loop of Y. between groups of sts. Return sts. on Lt. to D. pos. K.11 Rs. Return Ns. on Rt. to D. pos. K.19 Rs.\*

Repeat from \* to \*, making 5 holes in all. K. until band is long enough to fit up both fronts & across B.N. C/O.

Pin band in pos. around fronts & B.N. & sl. st. in place.

**Single-Bed M/cs.** Mark on Lt. front pos. for 5 buttons. The 1st  $\frac{1}{2}$  in up = front, the last at markers. C.O.B.H. 16 sts. T.9. K. band, making buttonholes, to correspond with button markers, over Ns. 4 & 5 from each end. K. until band fits up both fronts & across B.N. C/O. Pin band in pos. around front edges & sl. st. in place. Turn back band & secure in place. Finish off holes.

Press all seams & bands. Sew on buttons.



# girls raglan jumper 133



## BACK

**Step 1. Ribbers:** Cast onto 102 (110, 118, 126, 134) sts. T.7/6. K.2 Rs. Tub. T.8/7. K.18 Rs. 2 x 2 rib. Trans. Ns. to M.B.

**Single-Bed M/cs.** With W.wl. Cast onto 104 (110, 119, 128, 134) sts. \* Knit a few Rs. Trans. Ev. 3rd st. to Rt. Push empty Ns. back to A. pos. Change to M.wl.\* T.8. K.24 T.10. K.1 T.8. K.24. M.D.E. Unravel W.wl. T.9. K.1 Dec. to 102 (110, 118, 126, 134) sts. C.O.R. 000

**Step 2.** K.86 (92, 98, 104, 110) Rs. straight.

**Step 3.** C/O. 5 (6, 7, 8, 9) sts. at beg. next 2 Rs. C.O.R. 000

**Step 4.** Dec. 1 st. on each edge Ev. alt. R. 30 (32, 34, 36, 38) times. K. to 64 (66, 72, 74, 76) Rs. C.O.R. 000

**Step 5.** K.10 Rs. straight. Thread-up B.N. sts.

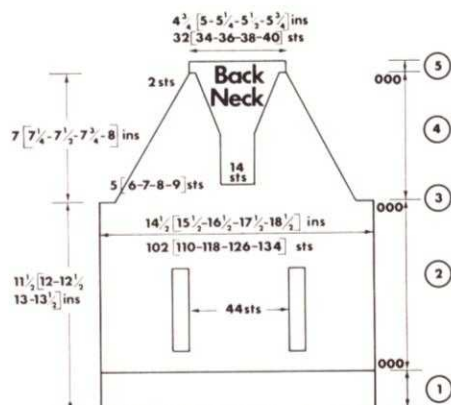

Boys or Girls Raglan Jumper

## FRONT

As for back, to end of step 1.

**Step 2.** As for back, at the same time after 12 Rs. make pocket-slits. **Pocket-opening.** Push 22 Ns. to Rt. of centre & Rem. to Ltd. of centre to E. pos. H.P. K.48 Rs. straight. Push all Ns. to E. pos. Return centre 44 Ns. to D. pos. Break off Y. K.48 Rs. Push all Ns. to E. pos. Return Ns. on Ltd. to D. pos except for 22 Ns. to Lt. of centre. Break off Y. K.48 Rs. Push all Ns. to E. pos. C.O.R. Continue front.

**Step 3.** As for back.

**Step 4.** As for back, at the same time after 14 (12, 10, 10, 10) Rs. make front-opening. **Neck-opening.**



C/O centre 14 sts. Push Ns. on Lt. to E. pos. H.P. K.26 Rs. straight. Dec. 1 st. on neck edge here, then Ev. 4 Rs. 6 (7,8,9,10) times. C/O Rem. 2 sts. Return Ns. on Ltd. to D. pos. K. as for Rt. neck, reversing all shapings.

### SLEEVES

**Step 1. Ribbers** Cast onto 42 (46, 50, 54, 58) sts. as 2 x 2 rib. T.7/6.

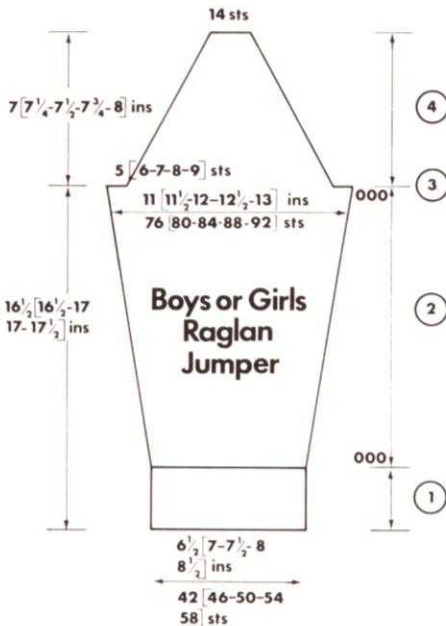

K.2 Rs. Tub. T.8/7. K.26 Rs. rib. Trans. Ns. to M.B.

**Single-Bed M/cs** With W.wl. Cast onto 44 (47,50,53,56) sts. As \* to \* of back, step. 1. T.8. K.30 T.10. K.1 T.8. K.30. M.D.E. Remove W.wl. Dec. or Inc. to 42 (46,50,54,58) sts. C.O.R. 000

**Step 2.** Inc. 1 st. on each edge Ev. 7 Rs. 17 times. K. to 126 (126,132,132,138) Rs.

**Step 3** As for back

**Step 4.** Dec. 1 st. on each edge Ev. 3 Rs. 12 (12,16,16,16) times. Then Ev. 2 Rs. 14 (15,12,13,14) times. K. to 66 (68,74,76,78) Rs. C/O Rem. sts.

### TO MAKE UP

Press all pieces.

**Pocket Bands:** Ribbers Cast onto 38 sts as 2 x 2 rib. T.7/6. K.2 Rs. Tub. T.8/7. K.8 Rs. rib. Trans. sts. to M.B.

**Single-Bed M/cs.** With W.wl. Cast onto 38 sts. As \* to \* of back, step 1. T.8. K.10 T.10. K.1 T.8. K.10. M.D.E. Unravel W.wl.

With Rt. side of work facing M/c, & starting 1 st. in from each edge, place edge of centre pocket-opening evenly onto Ns. K.1 C/O. Repeat for other centre opening.

**Pocket.** Pick up 38 loops from wrong side of C/O edge of pocket band, onto M/c. K.58 Rs. straight. Pick up loops from other C/O edge of band. C/O. Pick up 38 sts. from outer edge opening, K.58 Rs. Pick up edge of other opening & C/O. Sl. st. edges of bands onto front. Sl. st. of pocket together. Knit roulets 6 sts. & 4 sts. wide & apply to front, back & sleeves. Join sleeves, up to centre of top of sleeves, to back. Join other edges of sleeves up to top of shaping, to front. Press sleeve seams, bands & pocket. Join side & sleeve seams.

**Collar: Ribbers** Cast onto 134 (138, 146, 154, 158) sts. as 2 x 2 rib. T.7/6. K.2 Rs. Tub. T.8/7. K.8 Rs. rib.

**Buttonhole** Starting the 5th st. in from Lt. edge for girl, Rt. edge for boy, & using W.wl. K.4 sts. by hand. K.8 Rs. \*H.P.\* 18 sts. at opp. end of carr. on next 2 Rs. Then H.P. 1 st. Ev. alt. R. 9 times. Then 4 sts. Ev. alt. R. 6 times. Return Ns. to D. pos. at opp. end to carr. on next 2 Rs.\*

With Rt. side of work facing M/c, place side F.N. onto 21 sts. place side neck onto 30 (31,34,37,38) sts. & B.N. to 32 (34,36,38,40) sts. Place side neck to 30 (31,34,37,38) sts. & side F.N. to 21 sts. C/O to end.

**Single-Bed M/cs.** With W.wl. Cast onto 134 (137, 146, 155, 158) sts. As \* to \* of back, step 1, T.8. K.9. Buttonhole as for ribbed collar. K.9. Shaping as \* to \* of ribbed collar. T.10. K.1 T.8. H.P. \* 51 sts. at opp. end to carr. on next 2 Rs. Return 4 sts. to D. pos. Ev. alt. R. 6 times. Then 1 st. Ev. alt. R. 9 times.

Return Rem. 18 sts. to D. pos. on next 2 Rs. K.9 Rs. straight. Make buttonhole as before. K.9 Rs. M.D.E. Unravel W.wl. C/O collar as for ribber collar, Sl. st. edge of Rt. front band (girl, or Lt. front for boy) to C/O edge on front. On wrong side st. other edge of band to seam. Finish off buttonhole. Press all seams & collar. Sew on button.

# tots jumper 134

**Step 1. Ribbers.** Cast onto 78 (86,94,102) sts. as 2 x 2 rib. T.7/6. K.2 Rs. Tub. T.8/7. K.6 Rs. rib. Trans. Ns. to M.B.

**Single-Bed M/cs.** With W.wl. Cast on 77 (86,95,104) sts. \*K. a few Rs. Trans. Ev. 3rd. st. to Rt. Push empty Ns. back to A. pos. In M.wl.\* T.8. K.8 T.10. K.1 T.8. K.8. M.D.E. Remove W.wl. Dec. or Inc. to 78 (86,94,102) sts. T.9. K.1 C.O.R. 000.

**Step 2.** T.9. K.72 (82,92,102) Rs. straight.

**Step 3.** C/O 2 (3,4,5) sts. on each edge C.O.R. 000

**Step 4.** Dec. 1 st. on each edge Ev. R. 14 times. C.O.R. 000

**Step 5.** 28 (32,36,40) Rs. straight, at the same time after 24 (28,32,36) Rs. start

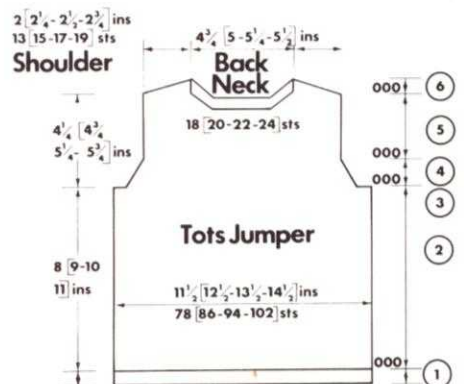



**Back Neck** Thread-up centre 18 (20,22,24) sts. & take off. H.P. sts. on Lt. On Rt. neck edge thread-up 1 st. Ev. R. 8 times.

**Step 6. Rt. Shoulder** At the same time as shaping neck edge. C.O.L. H.P. \* 5 (6,5,6) sts. on Rt. edge Ev. alt. R. 2 (2,3,1) times. Then H.P. \* 5 (5,4,5) sts. 1 (1,1,3) times. Return Ns. to D. pos. K.1 C/O.

**Left Neck** Return Ns. on Ltd. to D. pos. & work neck as before.

**Step 6. Lt. Shoulder** H.P. \* 5 (6,5,6) sts. on Ltd. edge Ev. alt. R. 2 (2,3,1) times. Then H.P. \* 5 (5,4,5) sts. 1 (1,1,3) times. Return Ns. to D. pos. K.1 C/O

**Front Neck** After 20 (24,28,32) Rs. Thread-up centre 18 (20,22,24) sts. & take off H.P. sts. on Lt. On Rt. neck edge thread-up 1 st. Ev. R. 8

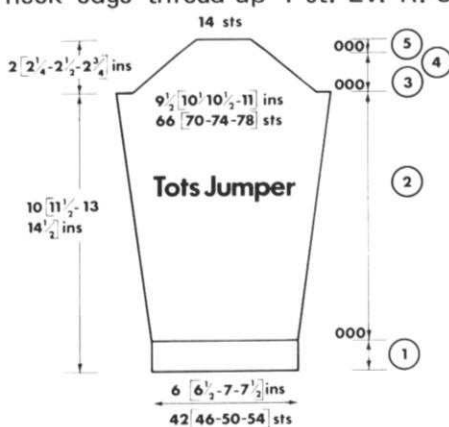

**Step 2.** Inc. 1st. on each edge Ev. 6 (7,8,9) Rs. 12 times. K. to 82 (96,110,124) Rs.

**Step 3.** As for back C.O.R. 000

**Step 4.** Dec. 1 st. on each edge Ev. R. 14 times. C.O.R. 000 times to 28 (32,36,40) Rs. C.O.R. 000

**Step 6. Rt. shoulder** As for back.

**Left neck** Return Ns. on Lt. to D. pos. Work Ltd. neck as for Rt.

**Step 6. Lt. shoulder** As for back.

## SLEEVES

**Step 1. Ribbers:** Cast onto 42 (46,50,54) sts. as 2 x 2 rib. T.7/6. K.2 Rs. Tub. T.8/7. K.12 Rs. rib. Trans. Ns. to M.B.

**Single-Bed M/cs.** With W.wl. Cast onto 41 (47,50,53) sts. As \* to \* of step 1. T.8. K.16 T.10. K.1 T.8. K.16 M.D.E. Remove W.wl. Dec. or Inc. to 42 (46, 50, 54) sts. T.9. K.1 C.O.R. 000

**Step 5.** H.P. \* 3 sts. at opp. end to carr. on next 4 (6,4,2) Rs. Then 2 sts. on next 4 (2,6,10) Rs. Return Ns. to D. pos. at opp. end to carr. on next 2 Rs. C/O

## TO MAKE UP

Press all pieces. Join shoulders.

**Neckband: Ribbers** Cast onto 78 (82,88,92) sts. as 2 x 2 rib. T.7/7. K.2 Rs. Tub. T.8/7. K.30 Rs. rib. Trans. Ns. to M.B.

**Single-Bed M/cs.** With W.wl. Cast onto 77 (83,89,92) sts. As \* to \* of step 1. T.8. K.10 T.10. K.1 T.8. K.10 M.D.E. Remove W.wl. Inc. or Dec. to 78 (82,88,92) sts.

With Rt. side of work facing M/c, place B.N. to 34 (36,38,40) sts.

Place side neck to 5 (5,6,6) sts. C/O up to this point. Place F.N. to 34 (36,38,40) sts. place side neck to 5 (5,6,6) sts. C/O to end. Join side of neck.

Knit roulets 4 sts. & 3 sts. wide & apply to front, back & sleeves. Sew tops of sleeves into armholes. Press seams. Join side & sleeve seams. Press all seams & band.





# girls pinafore dress 135



**Step 1 Ribbers.** Cast onto 106 (110, 118, 122) sts. as 2 x 2 rib. T.7/6. K.2 Rs. Tub. T.8/7. K.6 Rs. rib. Trans. Ns. to M.B.

**Single-Bed M/cs.** With W.wl. Cast onto 107 (110, 119, 122) sts. \*K a few Rs. Trans. Ev. 3rd st. to Rt. Push empty Ns. back to A pos.\* In M.wl. T.8. K.8 Rs. T.10. K.1 T.8. K.8 Rs. M.D.E. Remove W.wl. Dec. to 106 (110,118,122) sts. T.9. K.1 C.O.R. 000

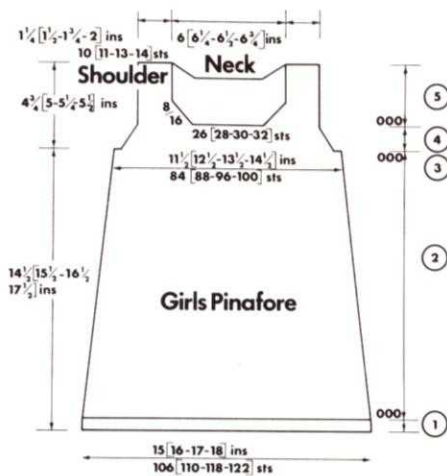

**Step 2.** T.9. Dec. 1 st. on each edge Ev. 11 (12,13,14) Rs. 11 times. K. to 126 (136,146,156) Rs.

**Step 3.** C/O. 4 (4,5,5) sts. on each edge. C.O.R. 000

**Step 4.** Dec. 1 st. on each edge Ev. alt. R. 7 times to 14 Rs. C.O.R. 000

**Step 5. Back** 32 (34,36,38) Rs. straight. After 22 (24,26,28) Rs. Thread-up centre 26 (28,30,32) sts. & take off. H.P. Lt. shoulder sts. On Rt. dec. 1 st. on neck edge Ev. R. 8 times. Thread-up shoulder sts. Repeat shaping for Lt. shoulder in same way.

**Front** After 8 Rs. Thread-up 26 (28,32,32) sts. at centre, & take off H.P. Lt. shoulder sts. On Rt. neck edge dec. 1 st. Ev. alt. R. 8 times. K. to 32 (34,36,38) Rs. Thread-up shoulder sts. Repeat for Lt. shoulder in same way.

**To Make Up** Press back & front, join side seams.

**Armbands: Ribbers** Cast onto 66 (70,74,78) sts. as 2 x 2 rib. K.2 Rs. Tub. K.4 Rs. rib. Trans. Ns. to M.B.



**Single-Bed M/cs. With W.wl.** Cast onto 68 (71,74,77) sts. Set Ns. as \* to \* of step 1. T.8. K.6 Rs. T.10. K.1 T.8. K.6 Rs. M.D.E. Remove W.wl.

With Rt. side of work facing M/c, place arm-opening evenly onto band & C/O.

Repeat for other opening.

**Back-band: Ribbers** Cast onto 78 (82,88,92) sts. as 2 x 2 rib. K.2 Rs. Tub. K.6 Rs. rib. Trans. Ns. to M.B.

**Single-Bed M/cs. With W.wl.** cast onto 80 (83,86,92) sts. Set Ns. as for \* to \* of step 1. T.8. K.8 Rs. T.10 K.1 T.8. K.8 Rs. M.D.E. Remove W.wl. Dec. or Inc. to 78 (82,88,92) sts.

With Rt. side of work facing M/c, place edge of armband to 4 sts. place shoulder to 10 (11,13,14) sts. side neck to 12 sts. front neck to 26 (28,30,32) sts, side neck, shoulder & edge of band as before. C/O to end.

**Front-band: Ribbers** Cast onto 94 (98,104,108) sts. as 2 x 2 rib. K. band as before at the same time after 3 Rws make buttonholes. Starting the 4th st. in from edge trans. 1 st. to Lt. of band & 1 st. to Rt. of band. (2 sts. in all). Leave space of 7 (9,10,11) sts. between holes, make next hole in same way (4 holes in all). K.3 Rs. Trans. Ns. to M.B.

**Single-Bed M/cs. With W.wl.** Cast 95 (98,104,107) sts. K. band as before. At the same time after 4 & 13 Rs. make buttonholes as for ribber band. Inc. to 94 (98,104,108) sts.

With Rt. side of work facing M/c, place edge of armband to 4 sts. shoulder to 10 (11,13,14) sts., place side neck to 20 sts. front neck to 26 (28,30,32) sts. side neck, shoulder & band edge as before. C/O to end.

Knit roulets for 'Aran' patterning 4 sts. & 3 sts. wide & apply to pinafore.

Press all seams & bands. Sew buttons onto back shoulders.



**Figure 1**

Diamond pattern made with two lengths of tubing, and bobbles.

**Figure 2**

Open cable made with 2 strips of wider tubing.

**Figure 3**

Closed cable made with two lengths of wide tubing.

**Figure 4**

Plait made with three lengths of tubing.

**Figure 5**

Alternate cable and diamond pattern with bobbles.

**Figure 6**

Cables are shown here as an attractive trimming for a plain glove.

**Figure 7**

A coat or long cardigan can be effectively trimmed with cables.

**Figure 8**

A plain dress lends itself to an Aran-style design.

**Figure 9**

Half cable and bobbles.

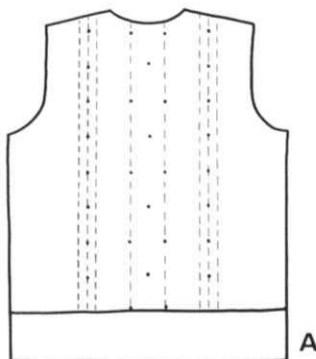
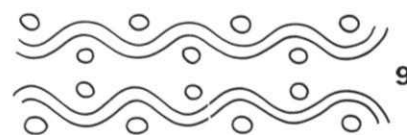
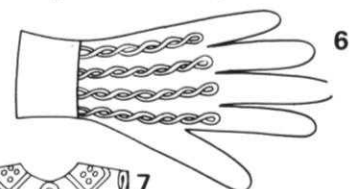
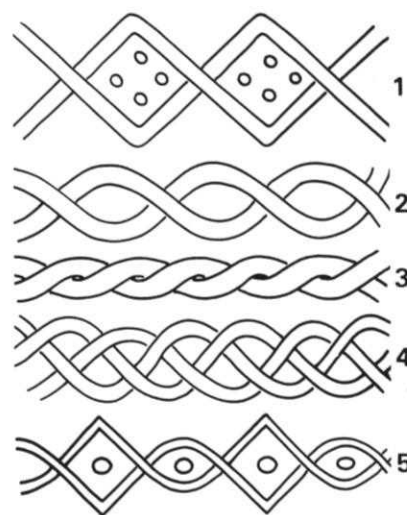

Mark out guide-lines for the pattern, on the garment with chalk or pins, using a tape measure to ensure correct spacing. (See figure A.)

Mark with pins the points where the pieces of tubing will cross or change direction. Again use a tape measure

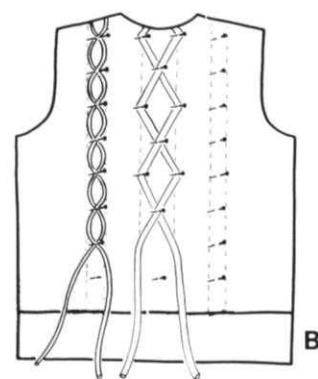

for accurate spacing. (See figures A and B.)

Pin the tubing in place taking care to cross over the pieces in the correct direction to create a balanced pattern. (Figure B.)



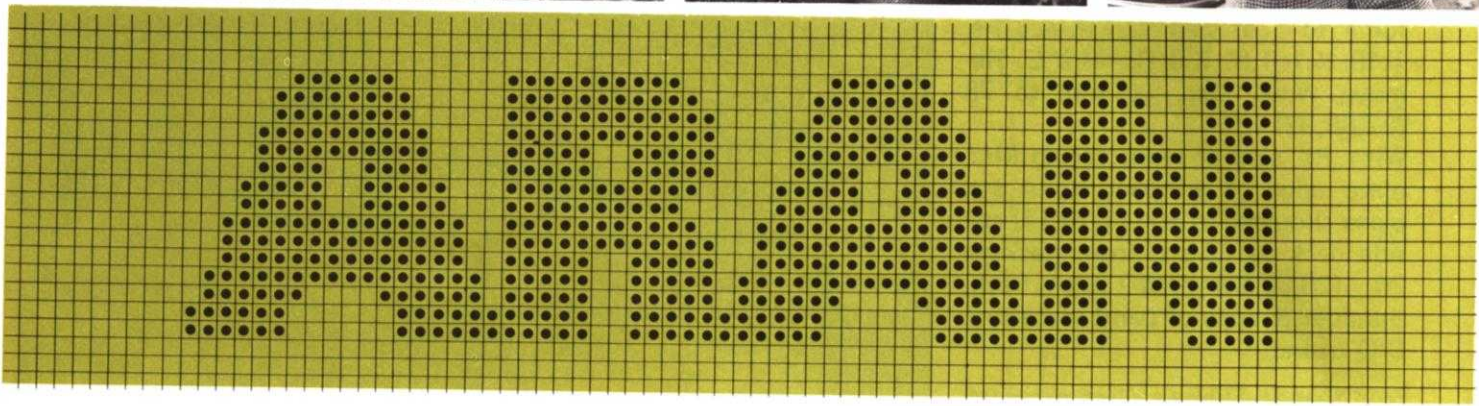

# Aran Style Patterns from Jones



**jones + brother**

Jones Sewing Machine Co. Ltd.,  
Shepley Street, Guide Bridge,  
Audenshaw, Manchester M34 5JD.











Dec. 1 st. at left edge (neck edge) next and following 6th row, knit to row 120. Cast off 5 sts. at beg of next row, K 1 row 000. Dec. 1st st. left edge.

**Step 3.** Dec. 1 st. at left edge every 6th row 0 (3,4,5) times then every 7th row 14 (12,12,12) times at the same time cast off 2 (2,3,3) sts. at beg of next row K 1 row. Dec. 1 st. at right edge every alt. row 5 (6,6,6) times then every 3rd row 5 times. Knit to row 106 (110,116,122) 27 (29,30,32) sts.

**Step 4.** Cast off 5 sts. at beg of next and every alt. row 3 (1,0,0) times then 6 sts. 2 (4,5,3) times then 7 sts. 0 (0,0,2) times. Knit other front to match reversing all shaping.

#### TO MAKE UP

Press all pieces. Join shoulder seams. Sleeve bands

**Ribbers.** Cast on 177 (185,193,199) sts. for 1 x 1 rib TO/O knit 3 rows Tub. T4/4 knit 14 rows. Trans. to main bed. \*With right side of work facing m/c place armhole edge to these sts. Cast off loosely\*.

**Mock rib.** Cast on alt. nds for 1 x 1 rib 177 (185, 193, 199) sts. T4 K 24 rows turn hem. Work as for ribbers from \* to \*.

**Plain edge** Cast on 132 (138,144,150) sts. T6 knit 24 rows. Turn hem work as for ribbers from \* to \*.

**Button band**

**Ribbers.** Cast on 187 (191,195,199) sts. for 1 x 1 rib TO/O knit 3

rows tub. T 4/4 knit 14 rows. Trans sts. to main bed. \*With right side of work facing m/c place right front to these sts. Starting 1 st. in from each end, place first 80 sts. from left of m/c between 2 markers. Place rem. sts. to neck edge to shoulder. Cast off loosely.\*

#### Woven

##### Ribbers

**Mock rib.** Cast on 187 (191,195,199) sts. on alt. nds for 1 x 1 rib T4 knit 24 rows. Turn hem work as for ribbers from \* to \*.

**Plain Edge** Cast on 141 (145,147,151) sts. T6 knit 24 row. Turn hem. Work as for ribbers from \* to \* placing first 60 sts. between markers.

##### Buttonhole band

**Ribbers.** Work as for button band making buttonholes on 7 over 4/5/6th nds from right edge \* miss next 16 nds\* rept. from \* to \* to make 5 buttonholes. Continue as for button bands. Placing 80 nds from right between markers.

**Mock rib.** Work as for button band making buttonholes on rows 6 and 18 over 5/6/7th nds from right edge \* miss 15 nds over next 3 nds\* rept. from \* to \* making 5 buttonholes. Continue as for button band placing 80 nds from right between markers.

**Plain edge** Work as for button band making buttonholes on rows 6 and 18 over 4/5/6th nds from right \* miss 10 nds over next 3 nds\* rept. from \* to \* making 5 buttonholes. Work as for buttonband placing 60 sts. from right between markers.

##### Back neck.

**Ribbers.** Cast on 45 (47,49,51) sts. for 1 x 1 rib. Knit as for sleeve band.

**Mock rib.** Cast on 45 (47,49,51) sts. on alt. nds for 1 x 1 rib knit as for sleeve band.

**Plain edge** Cast on 45 (47,49,51) sts. knit as for sleeve band. Join band edges and side seam. Turn up hem on fronts. Sew on button. Give final press.



# ladies ponchos

## Materials

Argyll Nice 'n' easy crepe double knitting.

Style A (with hood) 27 balls.

Style B (without hood) 25 balls

1 Toggle or button.

## Measurements

Medium 34/36 inch bust.

## Tensions

6½ sts x 9½ rows = 1 inch

T.D. approx 10.

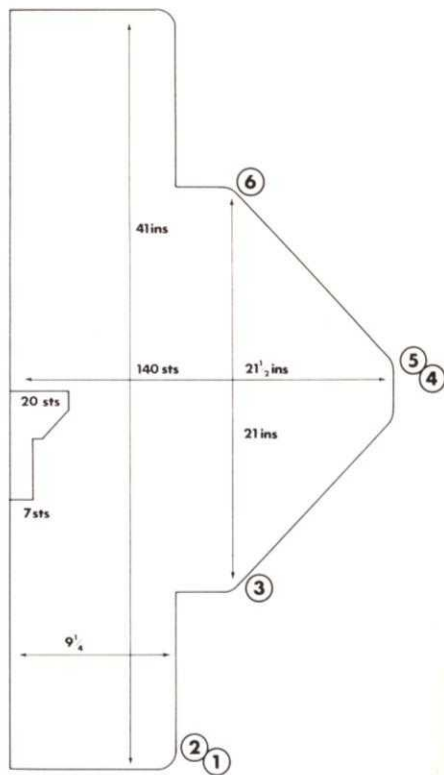

**Step 1.** C.O.B.H. 60 sts to left of centre 0. Push 21 sts into H.P. at the end of the next two rows. Ret 3 sts. to B pos. at the end of the next 8 rows. Ret 2 sts. to B pos. at the end of the next 6 rows. Ret. 1st to B pos. at the end of the next 6 rows. C.O.R.000.

**Step 2.** K 94 rows. Cast on 4 sts. at beg of next and every alt row 5 times, 80 sts. C.O.R.000.



**Step 3.** \* Inc. 1 st. at right edge on rows 1, 3, 5, 6\* (rept. from \* to \* 6 row rept.) until there are 140 sts. **At the same time** shape neck edge as follows. After row 41 cast off 7 sts. at neck edge. After row 69 cast off 4 sts. at neck edge Dec. 1 st. at neck edge every alt. row 9 times. K to row 100. 120 sts C.O.R. 000.

**Step 4.** K 1 row. Cast on 7 sts. at beg of next row K 1 row. Cast on 7 sts. at beg of next row, K 1 row. Cast on 6 sts at beg of next row 140 sts, K to row 10. C.O.R.000.

**Step 5.** \* Dec. 1 st. on right edge of rows 1, 3, 5, 6\* (rept from \* to \* 6 row rept.) to row 90 (80 sts). C.O.R. Cast off 4 sts. at beg of next and every alt. row 5 times. 60 sts. 000.

**Step 6.** K 94 rows. Push 1 st into H.P. at the end of the next 6 rows. Push 2 sts. into H.P. at the end of the next 6 rows. Push 3 sts. into H.P. at the end of the next 8 rows. Ret. all nds. to B pos. Cast off all sts. Knit another half to match reversing all shaping.

Press both pieces. Join centre seam. Style A (with hood)

From bands. C.O.B.H. 20 sts \*\* T8 K 18 rows T10 K1 row T8 K18 rows Turn hem. With right side of work facing m/c place left front opening to these sts. Cast off loosely.

**Buttonhole band** Knit as for buttonband making buttonhole on rows 9 over 4,5,6,7, 8th nds from right edge. With right side of work facing m/c place right front opening to these sts. cast off loosely. \*\*

rows turn hem. T10. 000.

**Step 2.** Dec. 1 st at both ends of every 5th row 5 times. K to row 46. Cast off 67 sts. at beg of next 2 rows. 000.

**Step 3.** K 36 rows. Dec 1 st at both ends of next and every following 10th row 4 times. K to row 84. Cast off. Press. Join back seams. Attach hood to neck edge with edges of hood half way across front bands.

#### Style B.

Neck band. C.O.B.H. 92 sts. T8 K12 rows. T10 K1 row. T8 K12 rows turn hem. With right side of work facing m/c place neck edge to these

sts. Front bands. C.O.B.H. 29 sts. Knit from \*\* to \*\* of style A. **EDGING** (both styles knitted on cross)

C.O.B.H. at extreem left of m/c 11 sts. T8 \* Dec 1 st at left edge and inc. 1 st at right edge every 4 rows.\* Rept from \* to \* until approx. 160 inches long. When work reaches right edge of m/c remove sts and replace at left end of m/c. Sew edging all round edge of tunic. Belt. C.O.B.H. 15 sts. T8 k approx. 50 inches. Cast off. Join seam and ends. Press. Sew on button, or toggle.

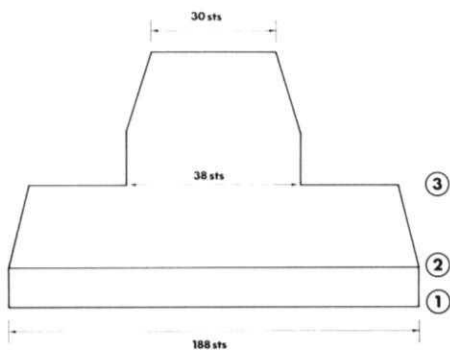

#### Hood

**Step 1.** C.O.B.H. 188 sts. T8 K40



# woven bath room set

## WOVEN BATHROOM SET

Featuring bath mat, pedestal mat and lid cover.

### Materials

Lee Target Super Crimp BRI nylon 20g balls

18 balls col. A

6 balls col. B

### Tensions

$7\frac{1}{2}$  st  $\times$   $11\frac{1}{2}$  row = 1 inch

820 patt, No. 285 from book T.8.

800 patt, No. 297 from book T.7.

588 patt, No. 925 from book T.7.

## LID COVER

**Step 1.** C.O.B.H. 31 sts. K.1 row set m/c for patt. inc. 1 st. at both ends of every row. 8 times then every alt. row to 101 sts. 000.

**Step 2.** Knit 62 rows.

**Step 3.** Dec. 1 st at both ends of every row to 31 sts., cast off. **Edging. Knit 2.** C.O.B.H. 141 sts. knit 10 rows turn hem. Knit 12 rows. Cast off. Join band together, back stitch band round the edge of lid cover from A. to A. Thread a length of elastic or cord through the hem and tie when in place on lid.

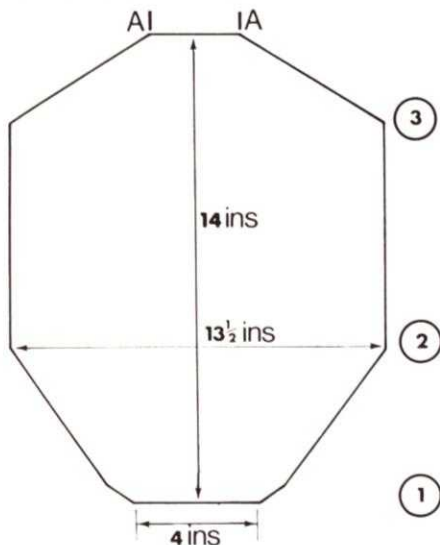

## PEDESTAL MAT

**Step 1.** C.O.B.H. 117 sts. in col. A k1 row set m/c for patt. Inc. 1 st. at both ends of every alt. row to 139 sts.

**Step 2.** Knit 136 rows. Cast off centre 61 sts. continue on right half only making a note of the pattern row. 000. Dec. 1 st, on inside edge every alt. row 8 times. Knit to row 74 dec. 1 st. both ends of every alt. row 8 times. Knit

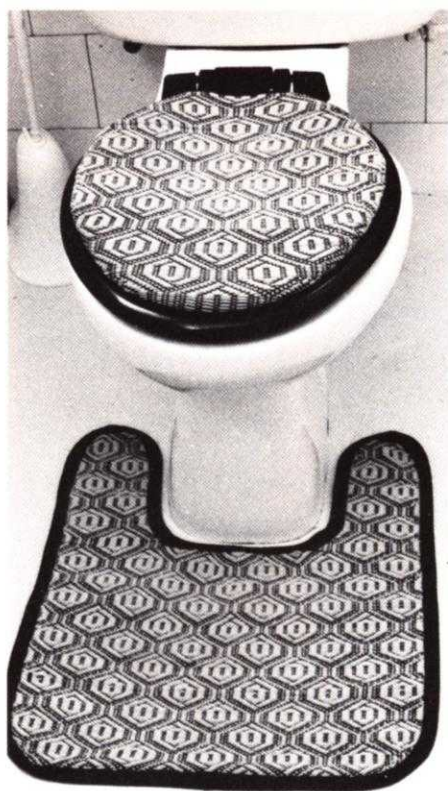

other half to match reversing all shaping.

**Edging. Inside knit 1.** C.O.B.H. 180 st. knit as for bath mat from \* to \*.

**Edging Outside knit 2.** C.O.B.H. 190 sts, knit as for bath mat from \* to \*

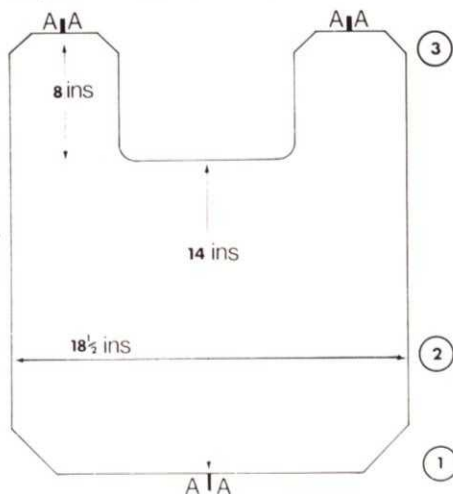

## BATH MAT

**Step 1.** In col. A. C.O.B.H. 117 sts. 1 row set m/c for patt. Inc. 1 st. at both ends of every alt. row to 139 sts.

**Step 2.** Knit 280 rows.

**Step 3.** Dec. 1 st. at both ends of every alt. row to 117 sts. Cast off.

**Edging Knit 4** C.O.B.H. 140 sts. \* T.6 Knit 10 rows T.8 knit 1 row. T.6 knit 8 rows. With right sides of work facing machine place work from point A to A. Cast off loosely. If you find it too difficult to do place the band on in one hook up and cast off in sections. Join edges of bands, fold band along loose row and sew down covering edge.\* Press.

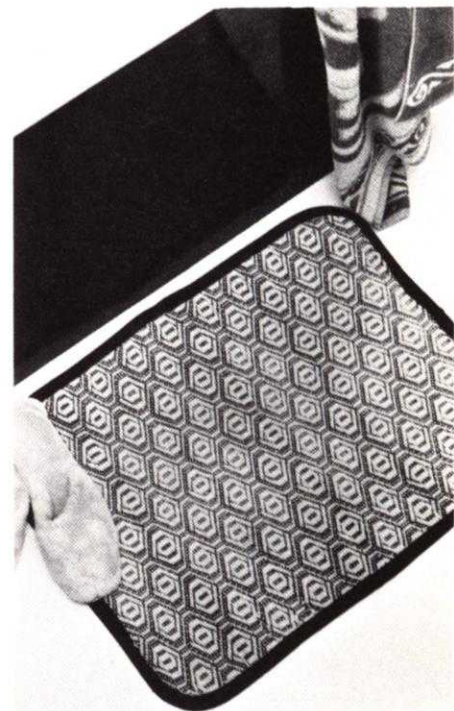
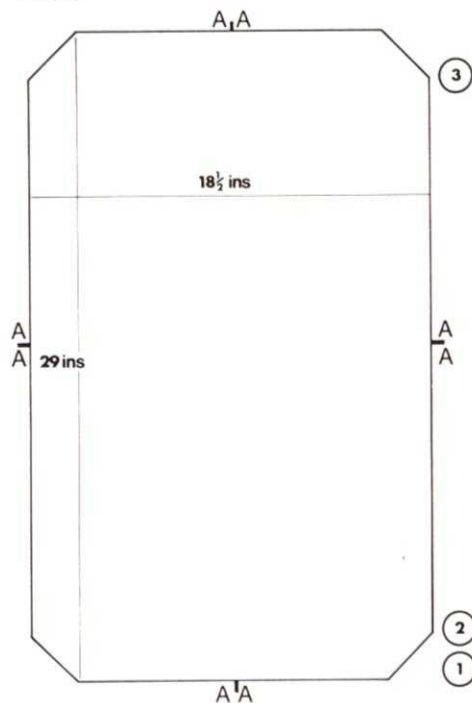



# abbreviations

This list of abbreviations can be cut out and glued to a piece of thick card or board. It can then be moved to whichever part of a pattern you are working on to save you constantly referring to the beginning.

- M.B. main bed
- st.st. stocking stitch
- sts. stitches
- beg. beginning
- dec. decrease
- inc. increase
- alt. alternate
- trans. transfer
- opp. opposite
- carr. carriage
- S.D. side dial
- W. WI. waste wool
- M. WI. main wool
- M1c(s). machine(s)
- pos. position
- 000 set counter at 000
- fol. following
- T. tension
- K. knit
- M.D.E. make double edge
- Ns. needles
- COL(R) carriage on left (right)
- patr. pattern
- rem. remaining
- H.P. holding cam lever(s) on holding position
- H.P.+ holding cam lever(s) on holding position and always take yarn around inside needle in E position
- C.O.B.H. cast on by hand
- on(s). inch(es)
- oz(s). ounce(s)
- tub. tubular
- p.b. part button
- f.f. fully fashioned
- Ev. every
- Lt. left
- Rt. right
- Rs. rows
- jacq. jacquard
- C/O cast off

Although most of the patterns are adapted to both machines, occasionally a designer who does not know the conversion, writes patterns merely for either the model 800 or the earlier models. If this occurs, please check with the chart below to find the correct settings for your H.C.L.'s.

- 800 H.C.L. 3 = I for all others
- 800 H.C.L. 1 = II for all others
- 800 H.C.L. 2 = III for all others

# fairisle tunic top

## Materials

Wendy Courtellon 4 ply.  
18 (20,22, 24) balls col A  
2 balls Col B & C  
1 ball Col D

## Measurements

To fit 34 (36,38,40) inch bust.  
86 (91,97,102) cms  
Back length 26½ (27,27½,28) ins  
67.5 (68.5,70,71)

Sleeve seam 13 ins. 33 cms.

## Tensions

7¼ sts. x 10 rows = 1 inch  
14½ sts. x 20 rows = 5 cms

over st. st. T.D. approx 8

Knit fairisle pattern one point looser.

Fairisle patterns from charts rept. once.

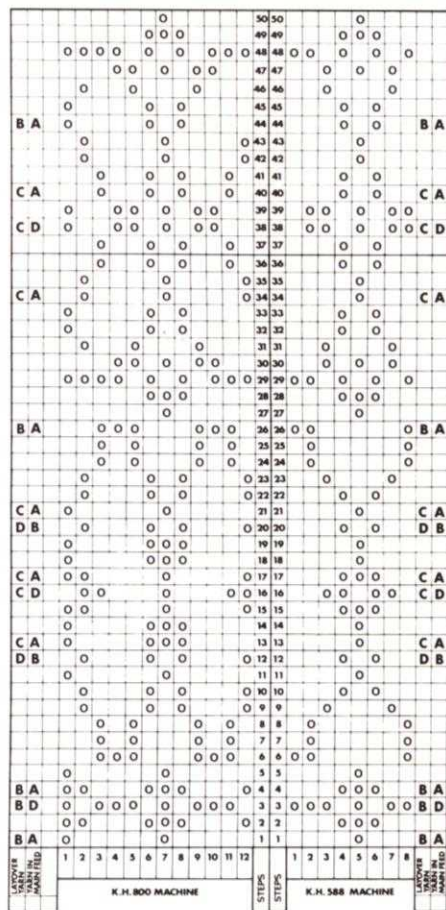
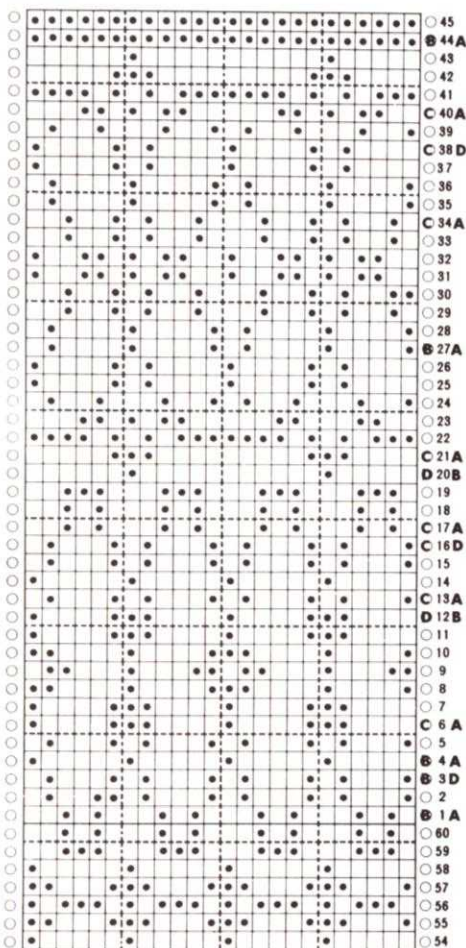

## BACK

Step 1. C.O.B.H. 145 (153,159, 167) sts. T6 K 20 rows 000.

Step 2. T8 K 3 rows Set m/c for pattern. K1 row T9 K1 rept. of pattern.

at the same time dec. 1 st. at both ends of every 24th row 7 times to 131 (139,145,153) sts. K to row 180. Cast off 11 (12,14,15) sts. at beg of next two rows. Cast off 12 sts. at beg of next two rows. 000

Step 3. K to row 86 (90,96,100) Cast off 6 sts. at beg of next 4 (6, 6,4) rows. Cast off 4 (0,0,8) sts. at beg of next 2 rows. Place rem 53 (53,55,55) sts. on waste yarn.

## FRONT

Knit as for back to row 160 of step 2. dec. centre st. to right continue



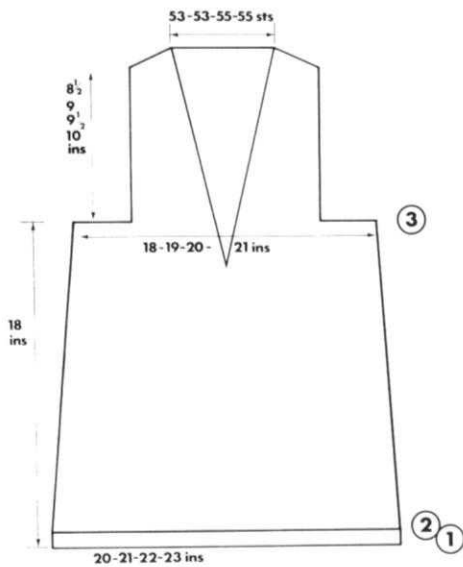

on right side only, knit as for back shaping on right edge only at the same time shape neck edge as follows. Dec. 1 st. at neck edge every 4th row 18 (14,13,9) times then every 5th row 8 (12,14,18) times, to 16 (18,18,20) sts. K to row 86 (90,96,100). Cast off 6 sts. at beg of next and every alt. row 2 (3,3,2) times. Cast off 4 (0, 0,8) sts. at beg of next row ret. sts. from left half knit as for right half reversing all shaping.

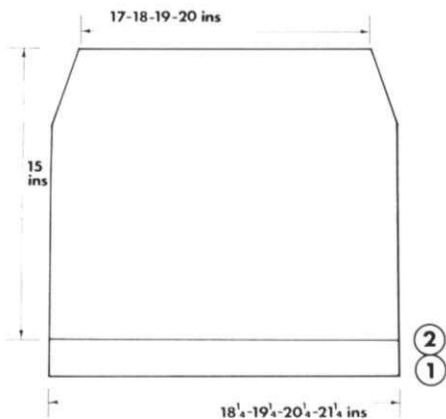

## SLEEVES

**Step 1.** C.O.B.H. 133 (141,147, 155) sts. T6 K 20 rows. T8 K 1 row T6 K 20 rows. Turn hem. \*T8 K 1 row. 000

**Step 2.** K to row 97 set m/c for patt. Cont. in patt. at the same time after row 114 dec. 1 st. at both ends of next and every following 7th row 5 times K to row 150.

## TO MAKE UP

Press all pieces. Join shoulder seams. Back neck band.

C.O.B.H. 55 (55,57,57) sts. T6 K as for step 1. of sleeve to \*

With right side of work facing m/c place sts. from back neck onto these needles starting 1 st. in from each end. Cast off loosely.

**Front band** C.O.B.H. 88 (91,95, 98) sts. Knit as for back band to \* With right side of work facing m/c place neck edge from 1 side onto these sts. starting 1 st. in from each end cast off loosely. Rept. for other half of neck edge.

Join rem. seams. Turn up hem. Give final press.





# fitted bunk bed cover

## Materials

Hayfields acrylic/nylon 4 ply.  
(Cones)

2 cones Col A

2 cones Col B

## Measurements

To fit standard bunk beds size

## Tensions and Patterns

6½ sts. x 9 rows = 1 inch over fair  
isle pattern.

T.D. approx 9.

820 follow chart.

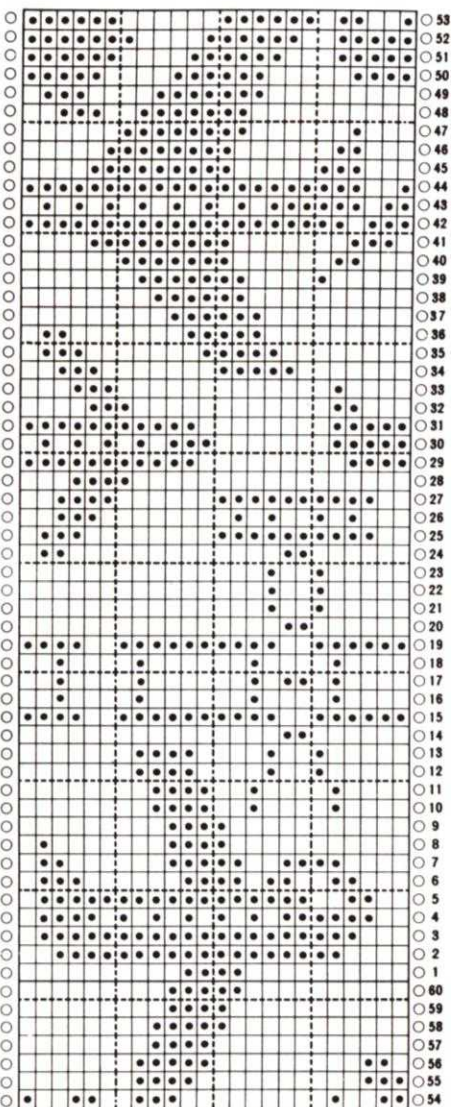

**Step 1.** In col B C.O.B.H. 85 sts. Starting 61 sts. to left of centre 0. T6 dec. 1st at right edge of every alt. row 5 times. T8 k 1 row T6 inc. 1st at right edge every alt. row 5 times. Turn hem T9 set m/c for patt. k 1 row. 000 C.O.R.

**Step 2.** With Col A in main feed and Col B as contrast. inc. 1 st. at right edge every alt. row 11 times, knit to row 50. 000 (96 sts.) C.O.R.

**Step 3.** Cast on 20 sts. at beg of next row. Inc. 1st at right edge every alt. row 15 times (131 sts.). Knit to row 650, cease pattern. In col B T6 inc. 1 st. at right edge every alt. row 5 times T8 k 1 row T6 dec. 1 st. at right edge every alt. row 5 times. Turn hem by picking up loops from first row of Col. B. Cast off loosely. Knit other half of cover to match reversing all shaping and starting 61 sts. to right of centre 0.

## EDGINGS

In Col. B C.O.B.H. 189 sts. T6 k 10 rows T8 k 1 row T6 k 10 rows turn hem, with right side of work facing m/c and starting 1 st. in from each end place bottom half of edge to these sts. (From point A to point B on chart) Rept. for other half.

Edging for top half.

In col. B C.O.B.H. 189 sts. T6 inc. 1 st. at right edge every alt. row 5 times T8 k 1 row T6 dec. 1st at right edge every alt. row 5 times. Turn hem. With right side of work facing m/c and 1st in from each end place left top half (from point b to point c on chart) edge to these sts. cast off loosely. Rept. for right top half shaping on left edge instead of right edge.

## TO MAKE UP

Press both pieces. Join centre seam 1st in from each edge matching up pattern (mattress st. is recommended for this). Sew seam at bottom corners as shown on chart. Join ends of edging.

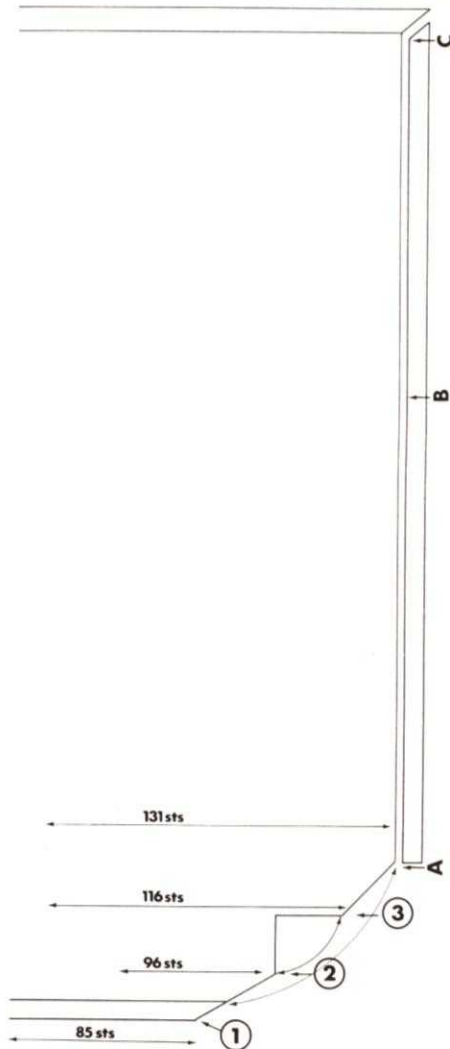
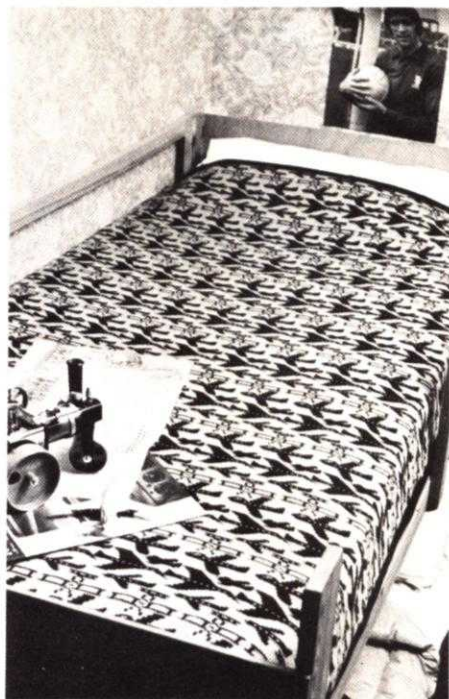

800 & 588 m/c.

No chart has been included for these m/c but as long as the correct tension is maintained any fairisle pattern can be used.



# babies lacy dress

## Materials

4, 20g balls of Sidar Wonderland Courtelle 3 ply. 4 small buttons. 1 yd. narrow ribbon. No. 10 crochet hook.

## Measurements

16 (18) in. chest.  
Sleeve seam 2(2) ins.  
Back length 15 (16) ins.

## Tension

7½ sts x 12 row = 1 inch over st.st.  
T.D. approx 4.

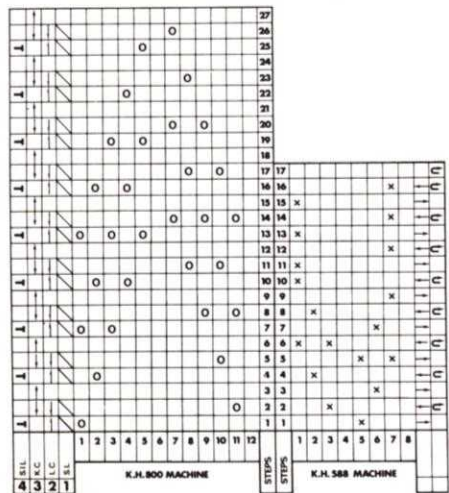
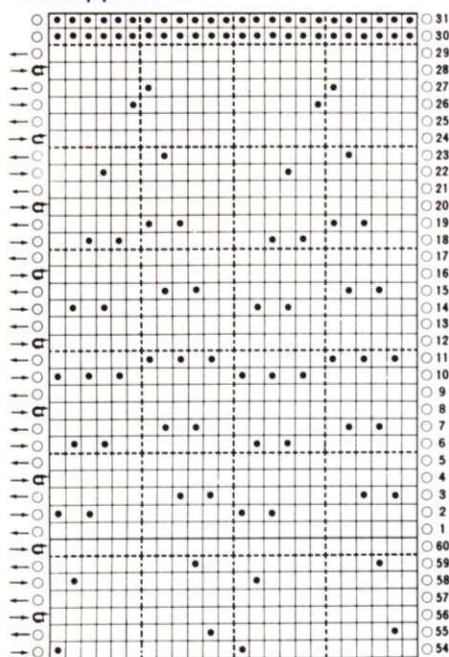

## SKIRT Knit two

Step 1. C.O.B.H. 99 (111) sts. (odd

needle at left edge of bed) T5 knit 9 rows, trans. every alt. st. to left T5 knit 10 rows. Turn hem.

Step 2. Knit 3 rows st.st. Set m/c for lace pattern, keep 2 sts at each end in st.st. Knit 5 (6) repts of lace pattern Knit 6 rows st.st. Place on

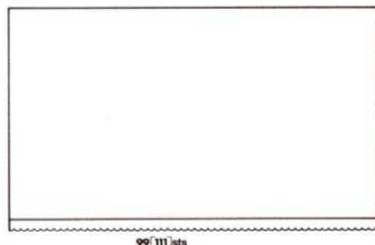

waste yarn. Knit another piece to match.

## YOKE FRONT

Step 1. With right side of work facing m/c replace sts. from one half of skirt onto 62 (70) sts. by hanging 1 st onto first 5 needles then \* 2 sts onto next 2 needles, 1 st. into next needle \* repeat from \*to\* to last five needles hang 1 st onto each needle. T4 knit 1 row, make row of holes by trans. very 3rd st. to adj. needle. Knit 7 (9) rows.

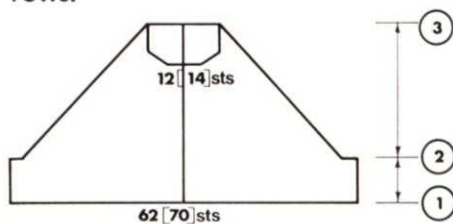



**Step 2. Armhole shaping** Cast off 3 (4) sts at beg of next 2 rows. Dec. 1 st at both end of every alt. row 12 (13) times; 32 (36) sts.

**Step 3.** Place centre 12 (13) sts onto waste yarn. Place sts on left into H.P. Working on right half only, continue dec 1 st at armhole edge every alt. row at the same time dec 1 st at neck edge every alt row 4 times. Continue shaping armhole edge until 2 sts remain, fasten off. Work left side to match, reversing all shaping.

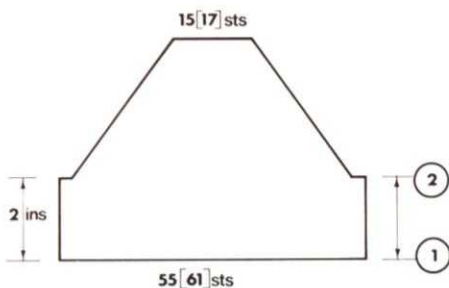

### YOKE BACK

Rehang skirt as for front yolk. Knit as for step 1 of front yolk.

**Step 2.** Starting from the 3rd needle to the left of centre 0 place all sts. to the left on waste yarn and continue on right half only.

**Armhole shaping** Cast off 3 (4) sts at begin of next row, knit 1 row. Dec. 1 st at beg of next and every alt row 19 (20) times 12 (14) sts. Place sts. on waste yarn. Return needles from left half to m/c cast on 4 sts at right edge for underlap. Knit as for right half reversing all shaping.

### SLEEVES

**Step 1.** C.O.B.H. 55 (61) sts having extra sts. to left of bed. T5 knit 2 row. Set m/c for pattern and work 1 rept. of lace pattern.

**Step 2.** Cast off 3 (4) sts at beg of next 2 rows. Cont. to knit lace pattern at the same time dec 1 st at both ends of every alt. row 17 (18) times. Place rem. 15 (17) sts on waste yarn.

**Sleevebands** C.O.B.H. 36 (38) sts. \* T4 Knit 5 rows. trans. every alt st. to left T3 knit 6 rows. Turn hem. \*

With right side of work facing m/c place bottom edge of sleeve onto these sts. gathering as for skirt. Cast off loosely.

### TO MAKE UP

Press all pieces. Join raglan seams.

### NECKBAND

C.O.B.H. 68 (74) sts. Knit as for sleeveband from \* to \* With right

side of work facing m/c place neck edge evenly onto these sts. Cast off loosely. Work 1 row of double crochet around back opening making 4 small loops for buttons evenly spaced up back opening.

Join side and sleeve seams. Press all seams. Sew of buttons and thread through the ribbon.

## pattern variation

### Materials

(4) 20g balls Sidar Wonderland 3 ply Courtelle. 3 small buttons. No. 10 crochet hook.

### Measurements

Chest 16 (18) ins.

Sleeve seam 1½ ins.

Back Length 14½ (15½) ins.

### Tensions

7½ st. x 12 rows = 1 inch over st.st.

T.D. aprox 4.

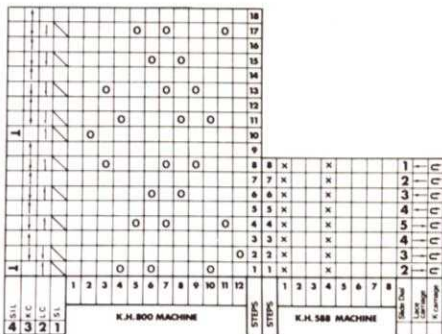
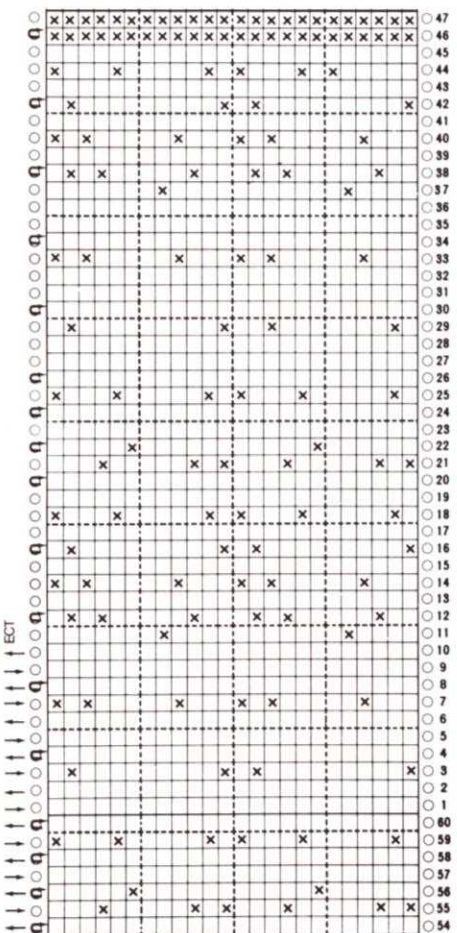

### BACK

**Step 1.** C.O.B.H. 108 (132) sts. T4 knit 10 rows. T10 Knit 1 row. T5 Knit 10 rows. Turn hem. Knit 2 rows set m/c for lace patt. 000.

**Step 2.** Keeping 2 sts. at each edge plain. knit to row 96 (104)\* Kit 2 rows st.st. Place piece on waste yarn.

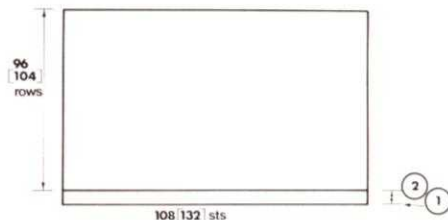

**Step 3.** Rehang skirt onto 61 (73) needles (method Place 1st onto first 7 needles, 2st onto every needle to the last 7 needles, 1st to each rem. needle) remove waste yarn. T4 knit 4 (8) rows in st.st. 000.

**Step 4.** Cast off 3 (4) sts at beg. of next 2 rows. Starting 3rd needle to left of centre 0. place sts. to left on waste yarn and cont. on right half only. Dec. 1 st. at beg of next and every alt rows 3 times. Knit to row 32 (36). C.O.R.



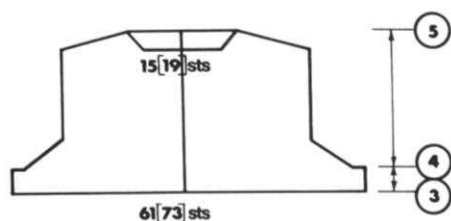

**Step 5.** Cast off 4 (5) sts at beg on next and every alt. row 3 times. Place rem. sts. on waste yarn. Return sts. from left back to m/c and cast on 4 sts. to the right for underlap, Knit as for right half reversing all shaping.

#### FRONT

Knit as for back to \* of step 2. Leave centre 12 sts on centre 12 needles rehang rem. sts. of skirt by placing 2 sts. onto each needle either side of centre needles 1st on last needle 61 (73) sts.

**Step 3.** Knit 6 (10) rows keeping 1rpt of lace pattern over centre sts. only. 000.

**Step 4.** Cast off 3 (4) sts at beg. of

next 2 rows. Dec. 1 st. at both ends every alt. rows 3 times. Knit to row 24 (26).

**Shape neck** Place centre 15 (19) sts onto waste yarn and continue on right half only. Dec. 1 st. at neck edge every row 3 times then every alt row 2 times. Knit to row 32 (36).

**Step 5.** as for back. Ret. sts. from left half to m/c and knit as for right front reversing all shaping.

#### SLEEVES

**Step 1.** C.O.B.H. 56 (60) sts. T5 knit 4 rows set m/c for lace pattern. Knit 6 rows.

**Step 2.** Cast off 2 (3) sts at beg of

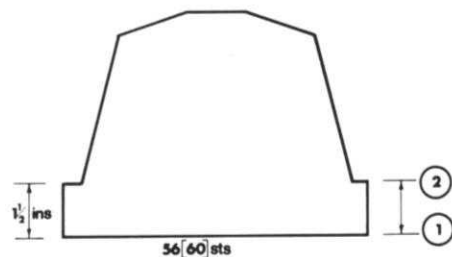

next 2 rows. Dec. 1 st at both ends of every row 4 times. Dec. 1 st at both ends of every alt row 20 times 24 (26) sts. Cast off 2 sts at beg of next 4 rows cast off rem. sts.

#### TO MAKE UP

Pin out and press all pieces.

#### SLEEVEBANDS

C.O.B.H. 36 (38) sts. T4 knit 4 rows. T10 knit 1 row, T3 knit 5 rows, turn hem. With right side of work facing m/c replace sts. from bottom of sleeve onto m/c gathering evenly. Cast off loosely.

#### NECKBAND

C.O.B.H. 68 (74) sts. Knit as for sleeveband. With right side of work facing m/c place neck edge evenly onto these sts. Cast off loosely.

Join side and sleeve seams, work a row of double crochet around back opening, making three loops evenly spaced on one edge for buttonholes. Press all seams. Sew on buttons.

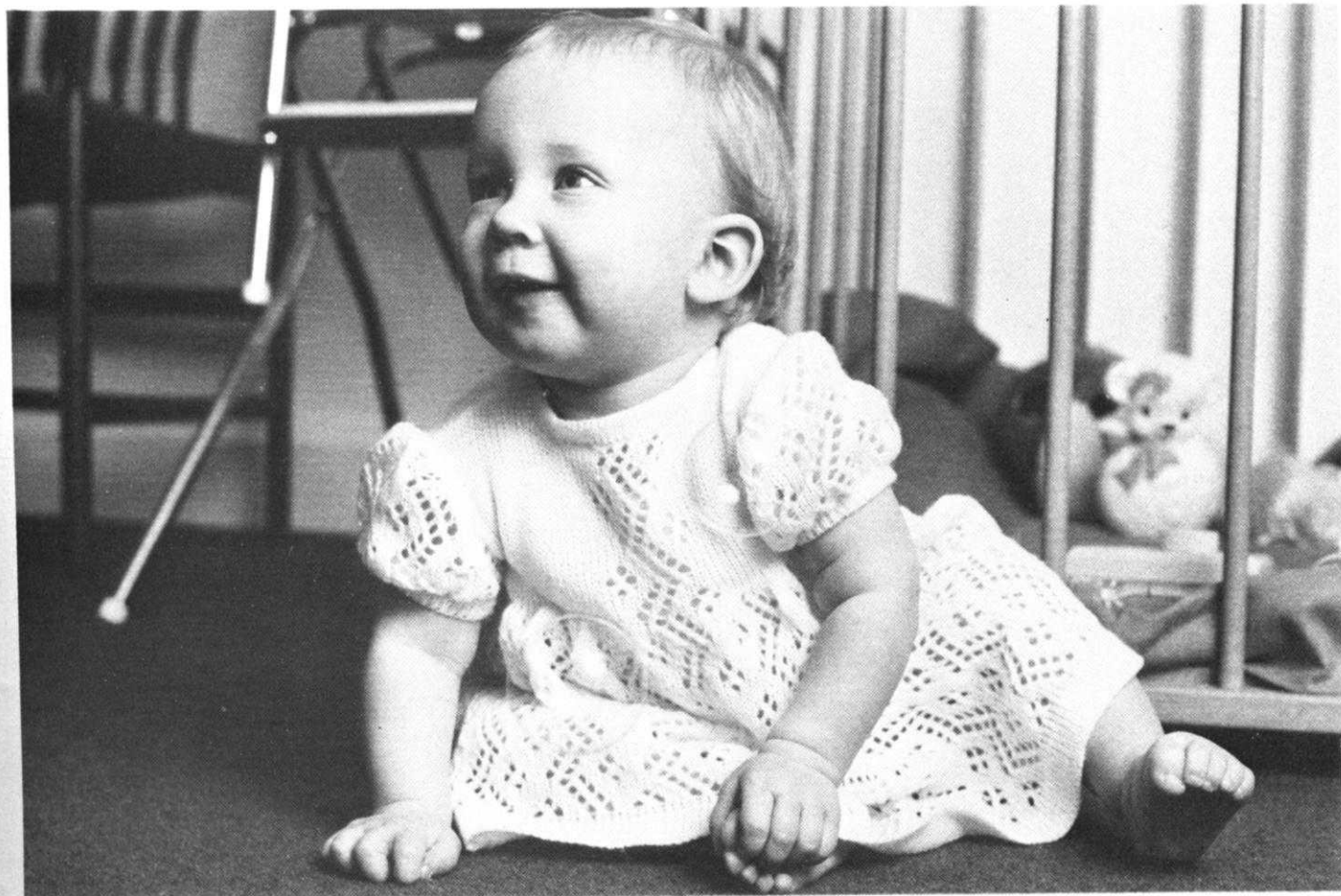



HERE  
IT IS—

THE NEW  
KH 830

TRUE LACE  
FINE LACE

Fairisle

WEAVING

BOLD  
MOTIFS

EXTENDED  
PATTERNS

FOUR  
COLOUR

Exciting knitwear designs for those special spring evenings, really beautiful feminine lace for summer, big, bold, colourful chunky outfits for autumn and warm woven suits for winter — they're all within the scope of this fantastic new KH830 knitting machine from Jones and a lot more besides!

True lace, fairisle, weaving and literally thousands of different pattern stitches are easily performed by the machine via punched cards. Now extra fine lace and an even greater flexibility of pattern/motif sizes are also possible. Add to the machine a striper attachment and four colours can also be worked and a striper used in conjunction with a ribbing attachment eliminates back loops with fairisle.

Take a look at the machine, its operation and the variations possible and you'll see why we say *knitting has never been so easy, so professional and so much fun!*



Just complete the coupon  
and we'll send you  
full details

Name \_\_\_\_\_

Address \_\_\_\_\_  
\_\_\_\_\_  
\_\_\_\_\_

Jb

jones + brother

To: Jones Sewing Machine Co. Ltd.,  
Britannia House, 964 High Road,  
Finchley, London N12 8LE.