

# stitchin' time

No. 29/30 70p



Jones/brother



# contents

Double Knit Ribbed Cardigan	3-4
Cable Dress	4-5
Woven Zip Jackets	6-9
Kiddies' Dungarees and Pinafore Dress	10-11
Gypsy Style Dress and Blouse	12-14
Matching Dress and Coat	15-18
Raglan Cardigan and Top	20-22
Woven Lace Patterned Coat	23-24
V-Neck Classic Sweater	25-26
Lacy Top Dress	26-27
Short Sleeved Jacket and Cardigan	28-31
Children's Windcheaters	32-33
Shawl Collared Jacket	36-38
Child's Bonnet and Scarf	38
Polo Necked Jumper and Cardigan	39-41
Man's Shawl-Collar Jumper	42-43
Man's Polo Neck Jumper	44-45
Man's Cardigan and Top	45-47
Man's Jumper and Waistcoat	48-51
Boy's Jazzy Jumper	51-53
Babies' Rompers and Pinafore Dress	53-54
His 'n' Hers Crew Neck Sweaters	56-57
Lacy Jumper and Hat	58-59
Ribbed Cardigan and Midi Skirt	60-61
Man's Cardigan and Vest	62-64
Fair Isle Jumper and Cardigan	65-67
Abbreviations	68

## broadly speaking

Difficulties at the beginning of the year have unfortunately had a drastic concertina effect on our production so we have to again apologise most sincerely for the late arrival of issue No. 4 of *Stitchin' time* and have decided to publish two issues, Nos. 4 and 5, together for a super bumper edition. This means that some of you whose subscription was due for renewal with No. 4 will apparently have received an extra copy, but when you renew your subscription it will in fact run from this 4th issue of the year to the 4th issue of the next year.

This super bumper issue really does carry something for everyone and there are a number of special offers which should provide some excellent ideas for Christmas presents. You will notice also that we proudly announce the arrival of our new knitting machine, the Knit-O-Matic, of which you will find further details on the centre spread of the magazine.

There are a number of patterns for the model 810 and the Knit-O-Matic and for the men of the family on the latter pages. The wool used in these garments was kindly supplied by Marshall Bros. (Wools) Ltd., Apperdale Mills, Apperley Bridge, Bradford, Yorkshire. They will be pleased to send a shade card on request. Similarly we have featured two garments, the boy's jazzy jumper (pages 51-53) and the raglan cardigan and top (pages 20-22) using yarn by Argyll Wools who now produce a range of wool on cone and all enquiries should be addressed to Argyll Wools Group, Priestley Mills, Pudsey, Yorkshire.

Many of the patterns in this issue are for specific machines and you may find that you cannot achieve the exact stitch pattern indicated in the picture. However, with a little bit of experimenting providing you get the right number of stitches and rows to the inch you should be able to produce a very nice garment using the pattern shape but substituting a different stitch pattern.

The staff of *Stitchin' time* would like to take this opportunity of wishing you a very merry Christmas and a happy New Year. Garment designs for '75 have already been started so we look forward to you continuing as subscribers to *Stitchin' time* and being able to offer you some really exciting pattern designs.

N.B. CHARTS SUBMITTED BY DESIGNERS VARY DEPENDING ON WHICH MACHINE THE DESIGNER HAS USED. MOST PATTERNS USING EIGHT BUTTONS CAN BE DONE ON EITHER THE 588 OR THE 585. THE DIFFERENCES ARE

588	585
REVERSE LEVER+	REVERSE DIAL A
REVERSE LEVER-	REVERSE DIAL B

**SUBSCRIPTION RATES FOR U.S.A. AND CANADIAN MEMBERS \$6.00.**

These rates include postage.



# double-knit ribbed cardigan

## Materials

27 (29, 31, 33, 35) balls. Lister Elle or Lee Target Titania, double knitting Courtelle/Bri Nylon. 5 buttons.

## Measurements

To fit 36 (38, 40, 42, 44) ins. chest.  
Length from shoulder 26 $\frac{3}{4}$  (27, 27 $\frac{1}{4}$ , 27 $\frac{1}{2}$ , 27 $\frac{3}{4}$ ) ins.  
Sleeve seam 18 (18, 18, 18 $\frac{1}{2}$ , 18 $\frac{1}{2}$ ) ins.

## Tension

With Y. feeder on loosest tension (i.e.—)

7 sts. and 12 rows to 1 in. on T8/7 over rib pattern.

3 $\frac{1}{2}$  [4-4 $\frac{1}{2}$ -4 $\frac{1}{2}$ -4 $\frac{1}{2}$ ] ins  
26 [28-30-32-34] STS  
SHOULDER

6 $\frac{1}{2}$  [6 $\frac{1}{2}$ -7-7 $\frac{1}{2}$ -7 $\frac{1}{2}$ ] ins  
45 [47-49-51-53] STS  
NECK

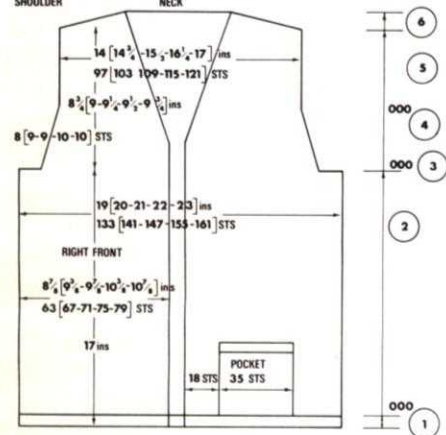

## BACK

**1. Hem** In D.K. Cast on 133 (141, 147, 155, 161) sts. as 1 x 1 rib. \* T5/5. K. 4 Rs. Tub. T8/7. K. 6 Rs. rib. Start patt. from graph. C.O.R. 000. \*

**2.** K. 194 Rs.

**3.** C/O 8 (9, 9, 10, 10) sts. at beg. next 2 Rs. C.O.R. 000.

**4.** Dec. 1 st. on each edge ev. 5 Rs. 10 times 50 Rs.

**5.** K. 58 (60, 62, 64, 66) Rs. straight.

**6.** C/O 6 sts. at beg. next 2 (6, 8, 6, 2) sts. Then cast off 5 (5, 6, 7, 7) sts. at beg. next 8 (4, 2, 4, 8) Rs. C/O.

## RIGHT FRONT

**1. Hem** Cast on 63 (67, 71, 75, 79) sts. as 1 x 1 rib, as \* to \* of back.

**2.** As for back. After 54 Rs. start pocket.

## POCKET

Starting the 19th N. in from front centre, (right) edge; thread up next 35 sts. and take off machine. With spare yarn, cast onto empty Ns. Place wire-loop weight hangers over these Ns. and hang on weights. (Push Ns. to C pos. for next few Rs.) Cont. to armhole.

**3.** K. 1. C/O 8 (9, 9, 10, 10) sts. K. 1. C.O.R. 000.

**4.** As for back, making dec. on Lt. edge. At the same time after 25 Rs. start Front Neck decs.



## NEEDLE ARRANGEMENT

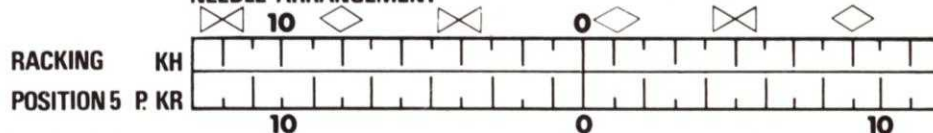

## FRONT NECK

With contrast Y. mark edge st. on centre. Dec. this st. 6 (9, 17, 20, 24) times. Work step 5 as for back.

**6. Shoulder** K. 1. C/O 6 sts. on Lt. edge ev. alt. R. 1 (3, 4, 3, 1) times. Then 5 (6, 6, 7, 7) sts. ev. alt. R. 4 (2, 1, 2, 4) times C/O.

## LEFT FRONT

As for right reversing all shapings.

## SLEEVE (knit 2)

**1. Hem** Cast on 59 (63, 67, 71, 75)

sts. as 1 x 1 rib. T5/5. K. 4 Rs. Tub. T8/7. K. 12 Rs. Rib. Start patt. from graph. C.O.R. 000.

**2.** Inc. 1 st. on each edge ev. 11 Rs. 17 times K. to 198 (198, 198, 204, 204) Rs.

**3.** C/O 8 (9, 9, 10, 10) sts. at beg. next 2 Rs. C.O.R. 000.

**4.** Dec. 1 st. on each edge ev. 5 Rs. 11 (12, 10, 8, 6) times. Then ev. 4 Rs. 0 (0, 3, 6, 9) times. K. to 60 (62, 64, 66, 68) Rs.



# cable dress

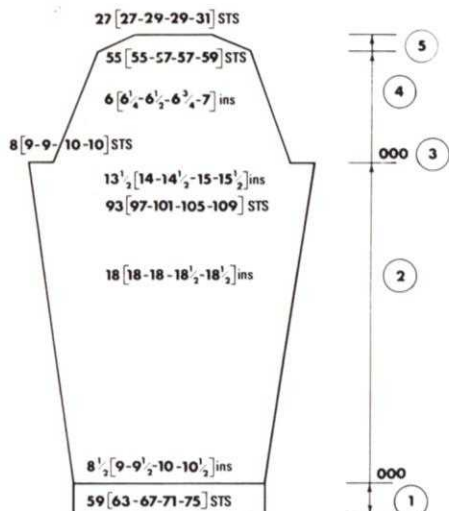

5. C/O 2 sts. at beg. next R. 14 times. C/O rem. sts. Press all pieces. Join shoulders. Sew tops of sleeves into armholes. Join side and sleeve seams.

## POCKET RIBS

Cast on 37 sts. as 1 x 1 rib. T5/5. K. 4 Rs. tub. T8/7. K. 6 Rs. rib. Trans. Ns. to M.B. with Rt. side of work facing machine and starting 1 st. in from each edge, place thread-up pocket sts. onto rib. C/O. Repeat.

## POCKET LININGS

Cast on 35 sts. in st.st. T8. K. 44 Rs. With Rt. side of work facing machine, place cast-on pocket sts. onto Ns. and C/O. Repeat. On right side of work st. down ribs. On inside of work st. down linings.

## FRONT BAND

C/O 16 sts. as 1 x 1 rib. T0/0. K. 4 Rs. tub. T3/2. K. 4 Rs. rib. H.C.L.'s II. \* Push Lt. 8 sts. to E pos. (on both beds). K. 8 Rs. Break off Y. Push Lt. 8 sts. to C pos. Push Rt. 8 sts. to E pos. Thread Y. between groups of Ns. K. 8 Rs. Break off Y. Push Rt. Ns. to C pos. K 34 Rs. \* Repeat from \* to \* making 5 buttonholes in all. K. until band is long enough to fit (stretching slightly) up both fronts and across back neck. C/O. Pin buttonhole band onto Lt. front with last hole next to marked st. St. in place. Cont. round B.N. and down Ft. front. Press all seams, pockets and band. Sew on buttons to correspond with holes.

6									"	"	"	→
5									"	"	"	→
4									"	"	<b>A</b>	→
3									"	"	"	→
2									"	"	"	→
1									"	"	<b>B</b>	→
STEPS	1	2	3	4	5	6	7	8	TUCK	REVERSE	KNOTS	DIR OF
	K.H. 588 MACHINE											CARR





### Materials

21 (23, 25) ozs. Lee Target Motoravia 4 ply. 18 ins. zip. Buckle.

### Measurements

To fit 38 (40, 42) ins. bust.

To fit 40 (42, 44) ins. hip.

Length from top of neck to hem  $40\frac{1}{2}$  ( $41\frac{1}{4}$ , 42) ins.

### Tension

7 sts. and  $9\frac{1}{2}$  rows to 1 in. T7.

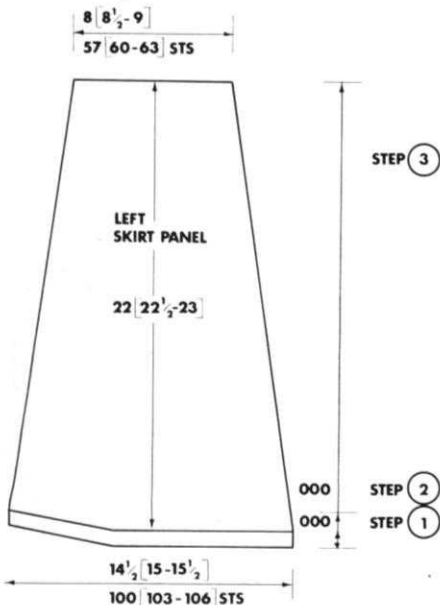

### SKIRT PANEL

1. C.O.B.H. 100 (103, 106) sts. T5. K. 9. T7. K. 1. T5. K. 9. M.D.E. T7. K. 1 row. C.O.R. 000. \* Trans. the 43rd N. in from right edge to the right. Trans. the 51st (54th, 57th) Ns. in from left edge to the left. \* Repeat trans. every alt. row.

2. H.C.L. II push 36 Ns. to E pos. at opp. end to carr. K. 1 row. Taking yarn round inside N., on next 4 every alt. row. K. 8 rows. Push 9 Ns. back to B at opp. end to carr. on next and every alt. row 4 times. \* Row 6 make cable by trans. 3 Ns. to right between trans., and replacing 3 right Ns. in left empty Ns. \* Repeat cable after every 12 rows. C.O.R. 000.

3. Dec. 1 st. on each edge every 9th row. 21 times to 58 (61, 64) sts. Lengthen or shorten here. K. to 202 (208, 214) rows. Dec. 1 st. on right edge. Thread up sts. and take off M/c. Repeat panel as above once more. For right panels. Repeat 2 panels reversing shapings at steps 1 and 2.

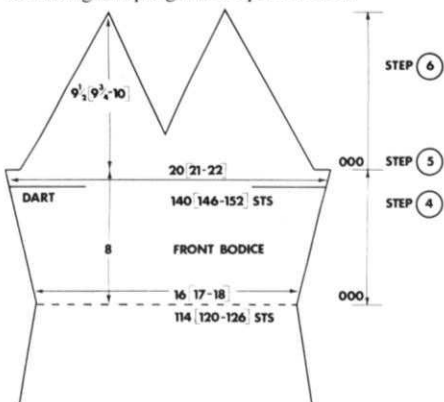

### FRONT BODICE

Place sts. of left panel to 57 (60, 63) sts. to left of centre M/c. Place sts. of right panel to right of centre. 114 (120, 126) sts. in all. \* Trans. the 4th N. from centre of M/c. to left. Trans. the 4th N. from centre of M/c. to right. \* Repeat trans. every alt. row. Continue trans. and cables as on skirt panels. C.O.R. 000.

4. Inc. 1 st. on each edge every 5th row 13 times. Row 66 \* H.C.L's II push 40 (40, 42) Ns. to E pos. K. 1. Always taking yarn round inside N. on next and every row. Push 40 (40, 42) Ns. to E pos. K. 1. Push back 10 (8, 7) on next 8 (10, 12) rows. \* C.O.R. 066. K. to 76 rows 140 (146, 152) rows.

5. Cast off 6 (7, 8) sts. at beg. next 2 rows to 128 (132, 136) sts. C.O.R. 000.

6. Dec. 1 st. on each edge every 3rd row 10 times, then dec. 1 st. on each edge every 2nd row 30 (31, 32) times. Start front neck row 18. Thread up sts. to left of centre and take off M/c. Dec. 1 st. on right neck and every foll. 4th row, 3 times, then dec. 1 st. every 3rd row 20 (21, 22) times. K. to 92 (94, 96) rows. Place left sts. back onto M/c. and repeat front neck step 6 reversing shapings.

### BACK BODICE

Place left and right panel onto M/c. as for front bodice omitting centre cable pattern.

4. As for front bodice to row 10. Zip opening. Thread up sts. to left of centre and take off M/c. Inc. 1 st. on left of remaining sts. Continue steps 4 and 5 as for front bodice (omitting \*).

6. Shape raglan as for front (omitting neck shaping). K. to 92 (94, 96) rows 25 (26, 27) sts. Thread up back neck sts. and take off M/c. Replace thread up sts. and continue as above reversing shapings.

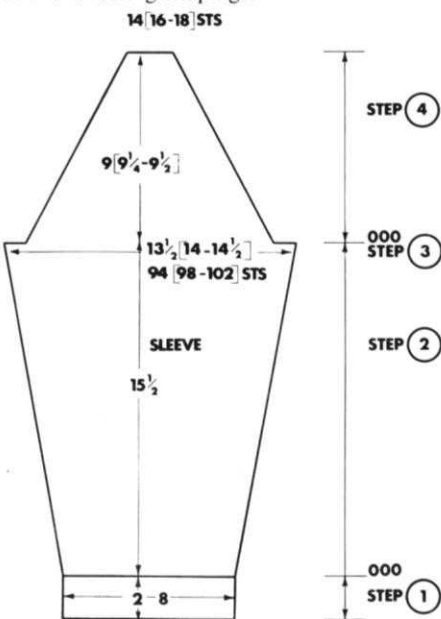

### SLEEVE

1. C.O.B.H. 58 sts. T5. K. 22. T7. K. 1. T5. K. 22. M.D.E. T7. K. 1 row. C.O.R. 000. \* Trans. the 4th st. from centre of M/c. to left and to right \* repeat every alt. row. Make cable as for skirt panel on 6th row and every foll. 12 rows.

2. Inc. 1 st. on each edge every 8 (7, 6)

rows 18 (20, 22) times to 94 (98, 102) sts. K. to 148 rows.

3. Cast off 6 (7, 8) sts. at beg. next 2 rows to 82 (84, 86) sts. C.O.R. 000.

4. Dec. 1 st. on each edge every 3rd row 16 (18, 20) times. Then dec. 1 st. on each edge every 2nd row 18 (16, 14) times to 14 (16, 18) sts. K. to 86 (88, 90) rows. Cast off. Repeat sleeve. Press back, front and sleeves. Join sleeve and bodice raglans, with centre of sleeve head meeting top of bodice. Join centre panels of skirt. Press all seams.

### NECKBAND

C.O.B.H. 74 (77, 80) sts. T5. K. 12 rows. Dec. 1 st. every alt. row on right edge 6 times. T7. K. 1 row. T5. K. 12 rows. Inc. 1 st. every alt. row 6 times. M.D.E. Place  $\frac{1}{2}$  back neck to first 24 (25, 26) sts. Place  $\frac{1}{2}$  front neck to 50 (52, 54) sts. and cast off. Repeat neckband, reversing mitred edge. Finish off mitre, press band.

### RIGHT COLLAR

C.O.B.H. 57 (61, 64) sts. T7. K. 19 rows. C.O.L. Push 32 Ns. to E pos. at opp. end to carr. H.C.L's II. K. 1 always taking yarn round inside N. on next and every alt. row K. 1 row. Push 8 Ns. back to B pos. on next 8 rows. T8. K. 1 row. T7. K. 1 row. C.O.L. Working from right edge trans. the 3rd N. to right. \* Miss next 6 Ns. trans. next N. to left. Miss next 3 Ns., trans. next N. to right. \* Repeat trans. to end of collar. Push 32 Ns. at opp. end to carriage. to E pos. H.C.L's II. K. 2. Push 8 Ns. back to B pos. on next 8 rows. \* Trans. 3 Ns. between trans. to right and replace 3 Ns. in left empty Ns. \* Repeat after next 12 rows. K. to row 57. C.O.L. T5. K. 6 rows. Inc. 1 st. on right edge every alt. row 3 times. T7. K. 1 row. T5. K. 6 rows. Dec. 1 st. every alt. row 3 times. M.D.E. Cast off. Press collar. Fold in half and st. along top of hem.

### COLLAR BAND

C.O.B.H. 18 sts. T5. K. 6. Inc. 1 st. on left edge every alt. row. T7. K. 1. T5. K. 6. Dec. 1 st. on left, every alt. row. M.D.E. Place longest edge of collar onto Ns. Working through both layers. Cast off. Join mitre. Press collar.

### LEFT COLLAR

C.O.B.H. 57 (61, 64) sts. T7. K. 20 rows. C.O.R. Continue shapings as for right collar, reversing shapings. Make trans. as for right collar, working from left edge. Continue reversing shapings. K. to row 57. Make hem as before reversing mitre edge. Cast off. Make collar band as above, reversing mitred edge. Press collar.

### TO MAKE UP

Starting  $1\frac{1}{2}$  ins. approx. from front mitre, sew top of collar to edges of neckbands, ending at back neck openings. Join side and sleeve seams. Crochet down zip opening. Insert zip. Press seams, crocheting and collar seam. On front and back corner tips of collar, secure in place by stitching onto bodice.

### BELT

C.O.B.H. 200 (110, 116) sts. T5. K. 5. T7. K. 1. T5. K. 9. T7. K. 1. T5. K. 5. M.D.E. Cast off. For last 2 sizes repeat belt and join seam. Fold along loose rows and st. 2 seams. St. to buckle. Press.

### FOR BELT LOOPS

Cast on 1 N. T2 with one p.b. in. K. a few rows. Repeat.



# woven zip-jackets

## STYLE A

Knitted to fit size 34 ins. bust. Zipped jacket featuring weave patt. front, with fabric used side-on. Worn with weave patt. skirt and hat.

## STYLE B

Knitted to fit size 28 ins. bust. Zipped jacket with saddle-shouldered sleeves and weave patt. bodice. Worn with weave patt. trousers and hat.

## Materials

**Jacket Style A** 10 (10, 11, 11, 12) balls of 4 ply. Colour A. 4 balls of double-knitting. Colour A. 4 balls of double-knitting. Colour B.  $\frac{1}{2}$  ball each of colours C and D in D.K. 16 (16, 17, 17, 18) ins. open-ended zip.

**Jacket Style B** 6 (6, 7, 7, 8) balls of 4 ply. Colour A. 3 balls of double-knitting. Colour A. 3 balls of double-knitting. Colour B.  $\frac{1}{2}$  ball each of colours C and D in D.K. Open-ended zip.

**Trousers** 9 (10, 11, 12, 13) balls of 4 ply. Colour A. 5 (5, 6, 6, 7) balls of double-knit. Colour A. 6 ins. zip.

**Skirt** 9 (9, 10, 10, 11) balls of 4 ply. Colour A. 4 (4, 5, 5, 6) balls of double-knitting. Colour B. 7 ins. zip.

**Hat Style A** 1 ball of 4 ply. Colour A. 1 ball of D.K. Colour B. Small ball each of colours A, C and D in D.K.

**Hat Style B** 1 ball of 4 ply. Colour A. 1 ball of D.K. Colour A. Small ball each of colours B, C and D in D.K.

**Yarns** By Robin—Vogue 4 ply and Vogue Double-Knitting.

## Measurements

To fit 28 (30, 32, 34, 36) ins. bust.  
Length of jacket from shoulder  $18\frac{3}{4}$  (19,  $19\frac{3}{4}$ , 20,  $20\frac{3}{4}$ ) ins.  
Inside sleeve measurement  $14\frac{1}{2}$  ( $15\frac{1}{2}$ ,  $16\frac{1}{2}$ , 17,  $17\frac{1}{2}$ ) ins.  
Trousers. Inside leg measurement 24 ( $26\frac{1}{2}$ , 29, 31, 33) ins.  
Skirt. Waist measurement 24 (25, 26, 27, 28) ins.  
Length from waist  $17\frac{1}{2}$  (19,  $20\frac{1}{2}$ , 22,  $23\frac{1}{2}$ ) ins.  
Hat. To fit small (medium, larger).

## Tension

6 sts. and  $9\frac{1}{2}$  rows to 1 in. on T8 over weave-pattern 1. (T8 $\frac{1}{3}$  on 810 M/cs.)  
7 sts. and 11 rows to 1 in. on T6 over weave-pattern 2. (T6 $\frac{1}{3}$  on 810 M/cs.)

**Note** When knitting welt in double-knitting on single bed M/cs., yarn feeder is on loosest (—) T.

**Abbreviations** D.K., Double Knitting; \* H.C.L.'s II \*, means always take yarn round inside needle in E pos.

**Note** When knitting weave always push each edge st. to weave pos. and lay yarn over these sts.





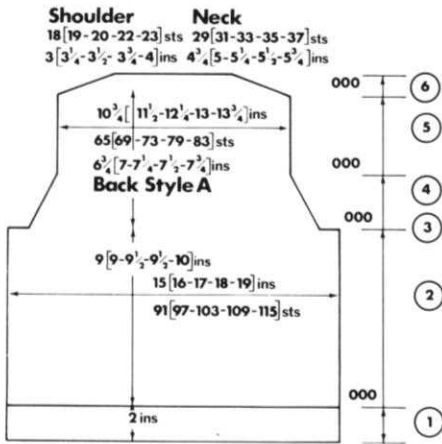

**JACKET STYLE A BACK**

**Step 1. Ribbers.** In colour B. Cast on 92 (98, 102, 110, 114) sts. as 2 x 2 rib. \* T4/4. K. 2 Rs. Tub. T8/8. K. 18 Rs. Rib. Trans. Ns. to M.B. \*

**Single bed M/cs.** With W. Wl. cast on 92 (98, 104, 110, 116) sts. \* K. a few Rs. Change to colour B. T7. (yarn-feeder on loosest tension). Trans. ev. 3rd. N. to Rt. Push empty Ns. back to A pos. K. 18 Rs. T9. K. 1. T7. K. 18 Rs. M.D.E. Unravel W. Wl.\*. Dec. or inc. 1 st. on Lt. edge to 91 (97, 103, 109, 115) sts. C.O.R. In colour A. 4 ply. T6. (Set M/c. to weave patt. 1 on 810 M/cs.) K. 1. C.O.L. 000. Start weave patt. 1 using colour A. D.K.

**Step 2.** T8. K. 85 (85, 89, 89, 93) Rs. straight.

**Step 3.** C/O. 4 (5, 6, 6, 7) sts. at beg. next 2 Rs. C.O.R. 000.

**Step 4.** Dec. 1 st. on each edge ev. 3 Rs. 9 times. K. to 30 Rs. C.O.R. 000.

**Step 5.** K. 36 (38, 40, 42, 44) Rs. straight. C.O.R. 000.

**Step 6.** \* H.C.L.'s II (800 H.C.L. I). \* Push 4 (4, 5, 5, 5) Ns. to E pos. at opp. end to carr. on next 4 (2, 4, 4, 2) Rs. Then 5 (5, 5, 6, 6) Ns. to E pos. on next 4 (6, 4, 4, 6) Rs. Return Ns. on Lt. to B pos. Set for weave. K.1. Return Ns. on Rt. to B pos. and set for weave. K. 1. C/O. shoulders. Thread-up back neck sts., and take off M/c.

**SLEEVES**

**Ribbers** In colour B. Cast on 42 (46, 46, 50, 50) sts. as 2 x 2 rib. T4/4. K. 2 Rs. Tub. T8/8. K. 22 Rs. rib. Trans. Ns. to M.B.

**Single bed M/cs.** With W. Wl. Cast on 41 (47, 47, 50, 50) sts. K. a few Rs. Change to colour B. Trans. ev. 3rd N. to Rt. Push empty Ns. to A pos. T7 (yarn-feeder on loosest tension). K. 22 Rs. T9. K. 1 T7. K. 22 Rs. M.D.E. Unravel W. Wl. Dec. or Inc. 1 st. on edge to 41 (45, 45, 49, 49) sts. C.O.R. In colour A. 4 ply. T6.

(Set M/c. to weave patt. 1 on 810 M/cs.) K. 1. C.O.L. 000. Start weave 19 [21-23-27-29] sts

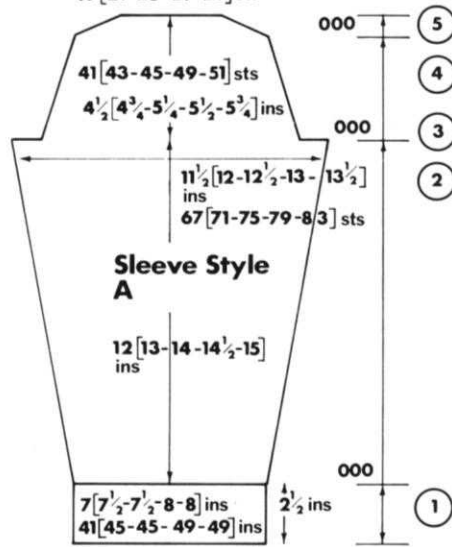

patt. 1 using colour A. D.K. T8.

**Step 2.** Inc. 1 st. on each edge ev. 8 (9, 8, 9, 8) Rs. 13 (13, 15, 15, 17) times. K. to 113 (123, 133, 137, 141) Rs.

**Step 3.** C/O. 4 (5, 6, 6, 7) sts. at beg. next 2 Rs. C.O.R. 000.

**Step 4.** Dec. 1 st. on each edge ev. 4 (6, 6, 6, 6) Rs. 1 (1, 5, 7, 9) times. Then ev. 5 Rs. 8 (8, 4, 2, 0) times.

C.O.R. 000.

**Step 5.** \* H.C.L.'s II (800 H.C.L. I). \* Push 2 Ns. to E pos. at opp. end to carr. on next 8 Rs. Then 3 Ns. to E pos. on next 2 Rs. Return Lt. Ns. to B pos. Set Ns. for weave. K. 1. Return Rt. Ns. to B pos. and set for weave. K. 1. C/O. Repeat sleeve.

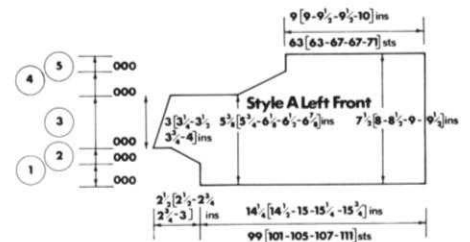

**LEFT FRONT**

In colour A. 4 ply. C.O.B.H. 99 (101, 105, 107, 111) sts. (51 sts. to Rt. of centre, the Rem. to Lt. of centre.) T6. (Set M/c. to weave patt. 2 on 810 M/cs.) K. 1. C.O.L. 000. Start patt. from graph.

**Step 1.** K. 14 (16, 18, 20, 22) Rs. straight. C.O.L. 000.

**Step 2.** Inc. 1 st. on Lt. edge ev. R. 12 times, to 111 (113, 117, 119, 123) sts. 12 Rs. C.O.L. 000. On Lt. edge cast on 7 sts. Hang on weight.

**Step 3.** Dec. 1 st. on Lt. edge ev. 4 (5, 5, 5, 6) Rs. 7 times. K. to 34 (36,

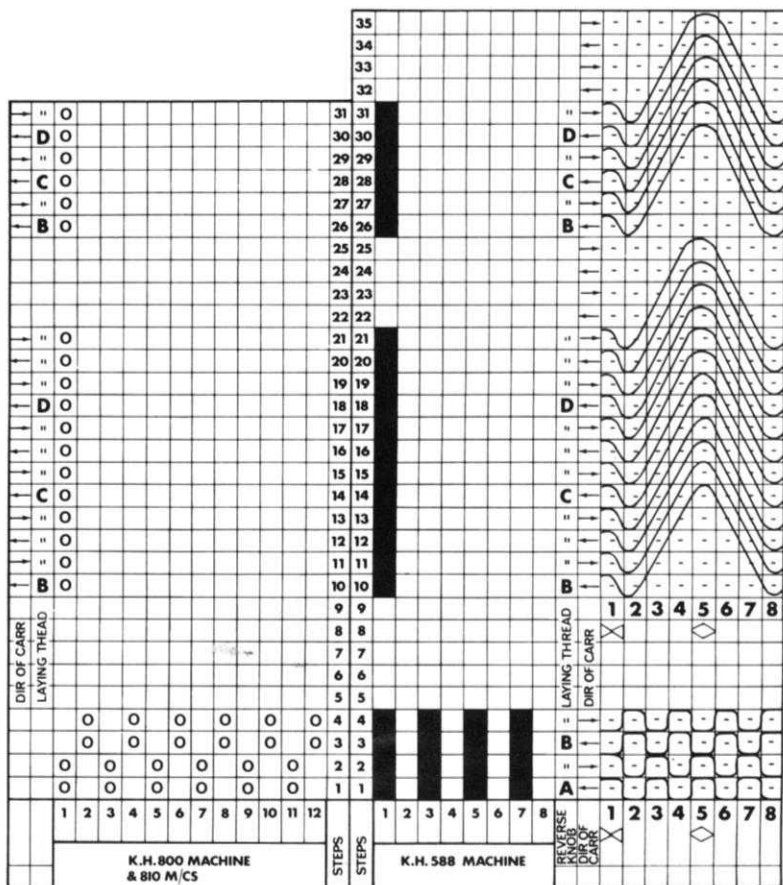

These 26 steps repeat from pattern 2

These few steps repeated from pattern 1



38, 40, 42) Rs. C.O.L. 000. On Lt. edge C/O. 27 (29, 29, 31, 31) sts.

**Step 4.** K. 1. C.O.R. \* H.C.L.'s II (800 H.C.L. I). \* Push 3 Ns. on Lt. edge to E pos. ev. alt. R. 7 times. H.C.L. I (800 H.C.L.'s III). K. 1. C/O. 21 sts. on Lt. edge. C.O.L. 000.

**Step 5.** K. 6 (8, 10, 12, 14) Rs. straight. C/O.

### RIGHT FRONT

C.O.B.H. as for L. (50 sts. to Lt. of centre, the rem. to Rt. of centre). Cont. as for L. front to step 2.

**Step 2.** As for Lt. making incs. on Rt. edge. K. 1. Cast on 7 sts. on Rt. edge. C.O.R. 001.

**Step 3.** Cont. as for Lt. front making decs. on Rt. edge. C.O.L. 000. K. 1. C/O. 27 (29, 29, 31, 31) sts. on Rt. edge.

**Step 4.** As for Lt. front making shaping on Rt. edge. C/O. 21 sts. on Rt. edge. C.O.R. 001.

**Step 5.** Cont. to 6 (8, 10, 12, 14) Rs. C/O.

### TO MAKE UP FRONT RIBS

**Ribbers** In colour B. Cast on 46 (50, 54, 58, 62) sts. as 2 x 2 rib. Make rib as \* to \* Back, step 1.

**Single bed M/cs.** With W. Wl. Cast on 47 (50, 53, 56, 62) sts. Make rib as \* to \* Back, step 1. With R. side of work facing M/c. and working through edge st. on work; place straight side of bodice piece evenly onto Ns. and C/O. in colour A. 4 ply. Repeat for other front. Press all pieces. Join shoulders. Sew tops of sleeves into armholes. Press seams. Join side and sleeve seams.

### COLLAR

**Ribbers** In colour B. Cast on 86 (90, 94, 98, 102) sts. as 2 x 2 rib. T4/4. K. 2 Rs. Tub. T8/8. K. 32 Rs. rib. Trans Ns. to M.B.

**Single bed M/cs.** With W. Wl. Cast on 89 (92, 95, 98, 101) sts. K. a few Rs. Change to colour B. T7. (Yarn-feeder on loosest tension.) Trans. ev. 3rd N. to Rt. Push back empty Ns. to A pos. K. 32 Rs. T9. K. 1. T7. K. 32 Rs. M.D.E. Unravel W. Wl. Inc. or dec. edge st(s). to 87 (91, 95, 99, 103) sts. With plain side of work facing M/c., place front neck to 29 (30, 31, 32, 33) sts. Place back neck to 29 (31, 33, 35, 37) sts. and rest of neck to rem. sts. C/O. in colour A. Press collar seam and side and sleeve seams. In colour B, crochet down fronts, working through ev. st. loop. Sew in zip. Press opening.

### JACKET STYLE B BACK

**Step 1. Ribbers** In colour A. D.K. Cast on 106 (110, 118, 126, 134) sts. as 2 x 2 rib. K. hem as \* to \* of Style A Back.

**Single bed M/cs.** With W. Wl. cast on 107 (113, 119, 125, 131) sts. K. as \* to \* of Style A Back. Dec. or Inc. to 105 (111, 119, 125, 133) sts.

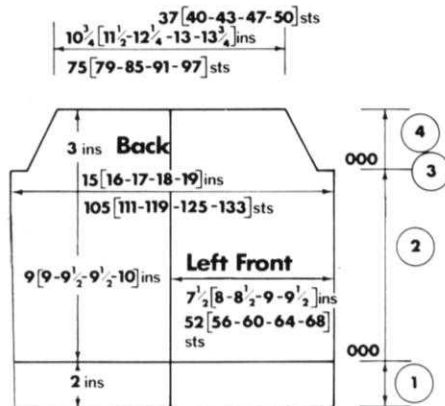

C.O.R. In colour A. 4 ply. (Set M/C. to weave patt. 2 on 810 M/cs.) T6. K. 1. C.O.L. 000. Start weave patt. 2 from graph.

**Step 2.** K. 98 (98, 104, 104, 110) Rs. straight.

**Step 3.** C/O. 4 (5, 6, 6, 7) sts. at beg. next 2 Rs. C.O.L. 000.

**Step 4.** Dec. 1 st. on each edge ev. 3 Rs. 11 times. K. to 34 Rs. Catch-up weave-threads. K. 1 row in plain st. C/O.

### RIGHT FRONT

**Step 1. Ribbers** In colour A. D.K. Cast on 54 (58, 62, 66, 70) sts. as 2 x 2 rib. Make hem as for back.

**Single bed M/cs.** With W. Wl. cast on 53 (56, 59, 65, 68) sts. Hem as for back. Dec. or Inc. to 52 (56, 60, 64, 68) sts. (Select slide-dial so that Right edge needle comes forward to D pos.) Cont. as for back to step 3.

**Step 3.** C/O. 4 (5, 6, 6, 7) sts. on Lt. edge. K. 2 Rs. C.O.L. 000.

**Step 4.** Dec. 1 st. on Lt. edge ev. 3 Rs. 11 times. K. to 34 Rs. Catch-up weave-threads. K. 1 R. in plain st. C/O.

### LEFT FRONT

As for Right for ribs. (Select slide-dial so that Left edge needle comes forward.) Place carr. on Lt. (Set M/c. to weave.) In 4 ply. T6. K. 1. C.O.R. 000. Cont. as for back to step 3.

**Step 3.** C/O. 4 (5, 6, 6, 7) sts. on Rt. edge. K. 2 Rs. C.O.R. 000.

**Step 4.** Dec. 1 st. on Rt. edge ev. 3 Rs. 11 times. K. to 34 Rs. Catch-up weave-threads. K. 1 in plain st. C/O.

### SLEEVES

K. as for Style A. Using colour B, D, K, to end of step 3.

**Step 4.** Dec. 1 st. on each edge ev. 5 (5, 6, 6, 7) Rs. 6 (6, 5, 5, 4) times. K. to 30 Rs. C.O.R. 000.

**Step 5.** Inc. 1 st. on each edge ev. 6 (6, 7, 7, 8) Rs. 8 times. After 38 (42, 46, 50, 54) Rs. push 29 (30, 32, 35, 36) Ns. on Lt. to E pos.

**Sleeve Top B** H.C.L.'s II. Dec. 1 st. on Lt. edge for 1 st. size only. Then, at the same time as working Incs. on Rt. edge., Dec. 1 st. on Lt. edge ev. 4 Rs. 5 times. After 50 (54, 58, 62, 66) Rs. K. 1. C.O.L. Always taking Y. round inside N. in E pos. on right edge, push 5 (5, 5, 6, 6) Ns. to E pos. ev. alt. R. 2 (4, 4, 2, 4) times. Then 4 (4, 5, 5, 5) Ns. to E pos. ev. alt. R. 4 (2, 2, 4, 2) times. Return Ns. to B pos. C.O.L. K. 1. C/O.

### Sleeve Top A

Return Lt. Ns. to B pos. C.O.R. 38 (42, 46, 50, 54) Rs. On Rt. edge C/O. 4 sts. ev. alt. R. 4 times, at the same time work Incs. on Lt. Edge. Then Dec. 1 st. on Rt. edge ev. 4 Rs. 2 (1, 1, 3, 3) times. After 50 (54, 58, 62, 66) Rs. On Lt. edge. Push 5 (5, 6, 6, 7) Ns. to E pos. ev. alt. R. 1 (1, 2, 2, 1) times. Then 4 (5, 5, 5, 6) Ns. to E pos. ev. alt. R. 2 (2, 1, 1, 2) times. C.O.R. Return all Ns. to B pos. K. 1. C/O. Repeat sleeve reversing all shapings at A and B. Press all pieces.

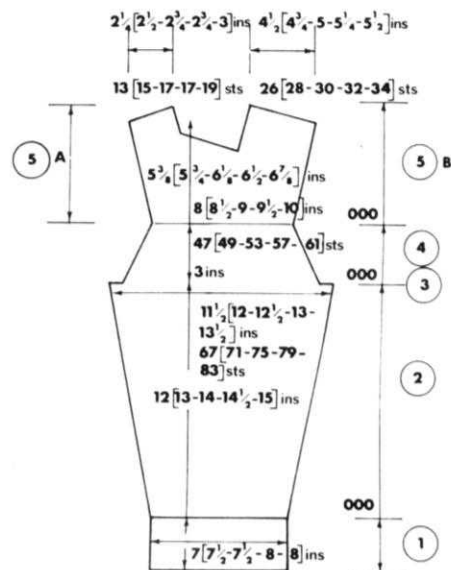

### To Make Up

Join sleeve tops together on B side, then join to top of back. Join A sides of sleeves to tops of fronts. Press all seams. Join side and sleeve seams.

**Collar** Cont. as for jacket Style A to end. Crochet down fronts in colour A. D.K. Cont. as for Style A.



## TROUSERS

### RIGHT LEG

**Step 1.** In colour A. 4 ply. C.O.B.H. 111 (123, 135, 141, 147) sts. T5. K. 12. T7. K. 1. T5. K. 12. M.D.E. (Set M/c. to weave patt. 1 on 810 M/cs.) T6. K. 1. C.O.R. 000. Start weave patt. 1 from graph using colour A. D.K. T8.

**Step 2.** K. 218 (242, 266, 284, 302) Rs. straight. (Adjust length at this stage.)

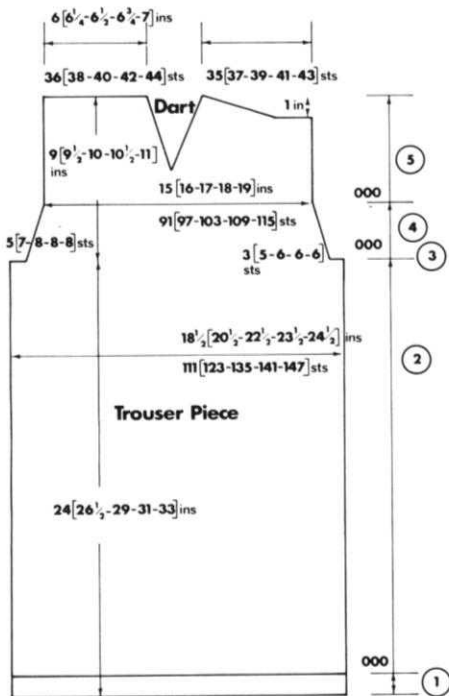

**Step 3.** C/O. 3 (5, 6, 6, 6) sts. at beg. next row. K. 1. C/O. 5 (7, 8, 8, 8) sts. K. 1. C.O.R. 000.

**Step 4.** Dec. 1 st. on each edge ev. 5 (4, 3, 3, 3) Rs. 6 (7, 9, 9, 9) times. K. to 30 (28, 28, 28, 28) Rs. C.O.R. 000.

**Step 5.** K. 28 Rs. straight. Thread-up and take off 46 (49, 52, 55, 58) sts. on Lt. edge. Cont. on Rt. sts. Dec. 1 st. on Lt. edge ev. 3 Rs. 10 (11, 12, 13, 14) times. At the same time after 48 (54, 58, 62, 66) Rs. C/O. 11 (13, 15, 17, 19) sts. on Rt. edge. K. 1. C.O.L. \* H.C.L.'s II. \* Push 5 Ns. to E pos. on Rt. edge ev. alt. R. 4 times. Return Ns. to B pos. Set for weave. K. 1. C/O. to end. Place Lt. sts. back onto same Ns. as before. C.O.R. 028. Dec. 1 st. on Rt. edge ev. 3 Rs. 10 (11, 12, 13, 14) times. K. to 58 (64, 68, 72, 76) Rs. C/O. Repeat for L. Leg, reversing all shapings at steps 3 and 5.

### TO MAKE UP

Press both pieces. Join back and front crutch seams. Sew up right dart. Join inside leg seams.

## WAISTBAND

In colour A. 4 ply. C.O.B.H. 138 (146, 154, 162, 170) sts. T5. K. 14. T7. K. 1. T5. K. 14. M.D.E. With Rt. side of work facing M/c. place front to 70 (74, 78, 82, 86) Ns. on Lt. C/O. up to this point. Place back to rem. Ns. and C/O. to end. Thread elastic through band and secure at each end. With No. 9 hook work 1 row of crochet on opening and waistband ends. Press all seams and opening. Sew in zip. Press in pleats.

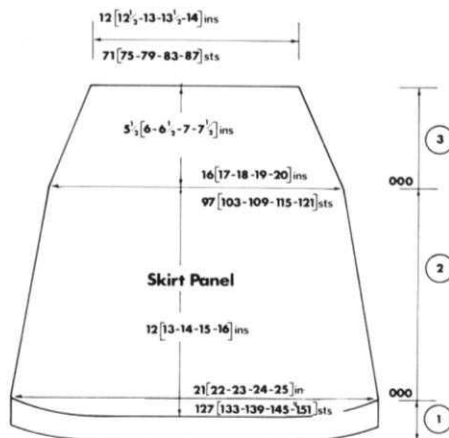

## SKIRT PANELS (Knit two)

**Step 1.** C.O.B.H. In colour A. 4 ply. 127 (133, 139, 145, 151) sts. T6. K. 15 Rs. (Set M/c. to weave patt. 1 on 810 M/cs.) T7. K. 1. C.O.R. Start weave patt. from graph, using colour B. D.K. T8. \* H.C.L.'s II. \* Push 24 (28, 32, 36, 40) Ns. to E pos. at opp. end to carr. on next 2 Rs. Return 6 (7, 8, 9, 10) Ns. to B pos. (by hand) and set for weave, at opp. end to carr. on next 8 Rs. C.O.R. 000.

**Step 2.** Dec. 1 st. on each edge ev. 7 (8, 9, 9, 10) Rs. 14 (9, 4, 14, 9) times. Then ev. 6 (7, 8, 8, 9) Rs. 1 (6, 11, 1, 6) times. K. to 104 (114, 124, 134, 144) Rs. C.O.R. 000.

**Step 3.** Dec. 1 st. on each edge ev. 4 Rs. 13 (14, 15, 16, 17) times. K. to 54 (58, 62, 66, 70) Rs. Thread up sts. and take off M/c.

### TO MAKE UP

Press both pieces. Join right side-seam. Join left seam, leaving 6 ins. opening for zip.

**Waistband** In colour A. 4 ply. C.O.B.H. 140 (148, 156, 164, 172) sts. T5. K. 14. T7. K. 1 T5. K. 14. M.D.E. With Rt. side of work facing M/c., place skirt sts. onto Ns. and C/O. Thread elastic through band and secure at each end. With No. 9 hook, work 1 row of crochet on opening and waistband ends. Press all seams and opening. Sew in zip.

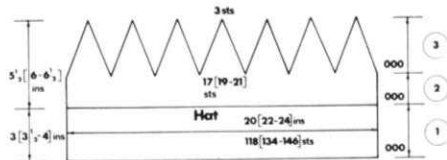

## HAT Style A

In colour B. Cast on 118 (134, 146) sts. as 2 x 2 rib. T4/4. K. 2 Rs. Tub.

**Ribbers** T8/8. K. 26 (30, 34) Rs. rib. Trans. Ns. to M.B.

**Single bed M/cs.** With W. Wl. Cast on 119 (134, 149) sts. K. a few Rs. In colour B. T7. (Trans. ev. 3 Rs. N. to Rt. Push empty Ns. back to A pos.) K. 14 (16, 18) Rs. T9. K. 1. T7. K. 14 (16, 18) Rs. M.D.E. Unravel W. Wl. C.O.L. (Set M/c. to weave patt. 2 on 810 M/cs.) In colour A. 4 ply. T6. K. 1. Inc. or dec. to 119 (133, 147) sts. C.O.R. 000.

**Step 2.** K. 16 Rs. of patt. 2 (reversing colour order). T6. On last row for 810 M/cs. set for weave patt. 1. K. 8 Rs. of patt. 1 using colour A. D.K. T8. (24 Rs. in all.) C.O.R. 000.

**Step 3.** H.C.L.'s II. Push 102 (114, 126) Ns. on Lt. to E pos. Leaving 17 (19, 21) sts. on Rt. edge in B pos. \* Dec. 1 st. on each edge ev 4 Rs. 7 (8, 9) times. K. to 30 (34, 38) Rs. Thread-up sts. and take off M/c. Return next 17 (19, 21) sts. (by hand) to B pos. and set for weave. \* Repeat from \* to \* to end of hat.

### TO MAKE UP

Join all seams. Turn back rib and join seam. Press all seams. Fold rib back and st. in place.

### Hat Style B

In colour A. D.K. K. ribs as for style A. Step 1. C.O.L. (Set M/c. to weave patt. 1 on 810 M/cs.) In colour A. 4 ply. T6. K. 1.

**Step 2.** K. 24 Rs. in weave patt. 1. T8. C.O.R. 000. Cont. to end of hat and make up as for Style A. Make multi-coloured pompon and secure to top of hat.



# kiddies dungarees and pinafore dress



Boys' dungarees and girls' pinafore dress featuring Jacquard around hem. 810 and 820 machines only unless motifs are worked by hand.

## Materials

**Dungarees** 8 (9, 10) balls dark shade of Robin Courtelle Crepe 4 ply. 1 ball of light shade Robin Courtelle Crepe 4 ply. 1 ball of medium shade Robin Courtelle Crepe 4 ply. 2 dungaree buckles.

**Pinafore Dress** 5 (6, 7) balls of dark shade Robin Courtelle Crepe. 1 ball

of light shade Robin Courtelle Crepe 4 ply. 1 ball of medium shade Robin Courtelle Crepe 4 ply. 2 buckles.

## Measurements

To fit 22 (24, 26) ins. chest.  
Dungarees Inside Leg  $13\frac{1}{2}$  (16,  $18\frac{1}{2}$ ) ins.  
Skirt Length from Shoulder  $19\frac{1}{2}$  (21,  $22\frac{1}{2}$ ) ins.



## Tensions

7 sts. and  $11\frac{1}{2}$  Rs. to 1 in. on T16 over st.st.

$7\frac{1}{2}$  sts. and 11 Rs. to 1 in. on T7 over jacquard.

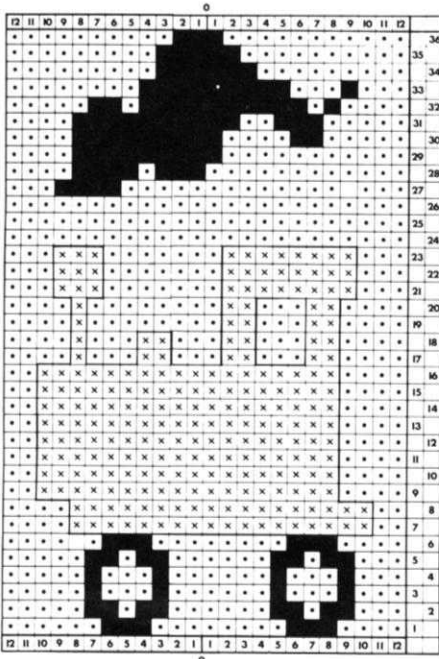

■ = Light shade  
x = Medium Shade  
• = Dark Shade

## DUNGAREES RIGHT LEG

**Step 1.** In M. WI. C.O.B.H. 108 (116, 124) sts. \* T5. K. 6 Rs. T7. K. 1. T5. K. 6 Rs. M.D.E. \* T6 (810 M/cs.

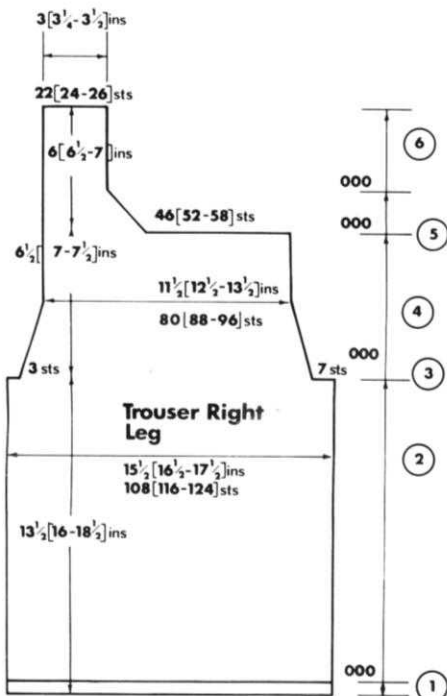

T6 $\frac{2}{3}$ ). K. 1. C.O.R. 000.

**Step 2.** K. 23 Rs. Set M/c. for jacq. K. 1. C.O.R. T7. (810 M/cs. T7 $\frac{2}{3}$ .) Start patt. from graph. K. one repeat of patt. (to 60 Rs.) T6. (T6 $\frac{2}{3}$ .) Cont. in plain st. to 150 (178, 206) Rs. Lengthen or shorten here.

**Step 3.** C/O. 7 sts. on Rt. Edge. K. 1. C/O. 3 sts. on Lt. edge. K. 1. C.O.R. 000.

**Step 4.** Dec. 1 st. on each edge ev. 4 Rs. 9 times. K. to 74 (80, 86) Rs. Lengthen or shorten here. C.O.R. 000. Thread-up 46 (52, 58) sts. on Rt. Edge and take off M/c.

**Step 5.** Dec. 1 st. on Rt. edge ev. alt. R. 12 times. 24 Rs. in all. C.O.R. 000.

**Step 6.** K. 44 (50, 56) Rs. straight. Thread-up sts. and take-off M/c. Repeat for L. leg, reversing all shapings.

## TO MAKE UP

Press both pieces. Join front and back seams. Join inside leg seams. Press seams.

## FRONT BAND

In M. WI. C.O.B.H. 46 (50, 54) sts. \* T5. K. 6 Rs. Inc. 1 st. on each edge ev. alt. R. 3 times. T7. K. 1. T5. K. 6. Dec. 1 st. on each edge ev. alt. R. 3 times. M.D.E. \* Starting 1 st. in from each edge, place front bib sts. onto Ns. and C/O.

## BACK BAND

In M. WI. C.O.B.H. 166 (180, 194) sts. Make band as \* to \* of front band. Starting 1 st. in from each edge, place side of bib to 43 (45, 47) sts. Place back sts. onto 80 (90, 100) sts. (Doubling-up on some sts) and side of bib to rem. Ns. C/O. Join mitres and press bands.

## POCKET

In W. WI. cast on 18 sts. (on 810 M/c. cast on 10 sts. to Lt. Centre. 8 sts. to Rt.) K. a few Rs. Change to M. WI. T6. (810 M/cs. T6 $\frac{2}{3}$ .) C.O.R. 000. K. 2 Rs. Set M/c. to jacq. K. 1. C.O.L. Start jacq. from graph. **At the same time** Inc. 1 st. on each edge ev. alt. R. 7 times. To 14 Rs. (32 sts.) Cont. straight to 42 Rs. in all. Thread-up sts. and take off M/c.

**Note** To isolate motif only select one jacquard repeat in centre of M/c. Push adjacent selected Ns. back to B pos. Always push each edge N. to C pos.

## Top Pocket Band

In contrast WI. C.O.B.H. 34 sts. Make band as \* to \* of front band. Starting 1 st. in from each edge, place pocket top sts. onto Ns. and C/O. in M. WI.

## Pocket Band

C.O.B.H. 64 sts. Make band as before. Starting 1 st. in from each edge place side of pocket to 24 Ns. Bottom of pocket to 14 sts. and rest

of pocket to rem. Ns. C/O. in M. WI. Finish off mitres. Press pocket and bands. Place onto front bin and pin in pos. On wrong side catch down pocket in place.

## Shoulder Straps

In M. WI. C.O.B.H. 82 (88, 94) sts. T5. K. 7 Rs. Dec. 1 st. on Lt. edge ev. alt. R. 3 times. T7. K. 1. T5. K. 6 Rs. Inc. 1 st. on Lt. edge ev. alt. R. 3 times. K. 2. Dec. 1 st. on Lt. ev. alt. R. 3 times. T7. K. 1. T5. K. 8 Rs. Inc. 1 st. on Lt. ev. alt. R. 3 times. M.D.E. C/O. Repeat making mitre on Rt. edge. Press band flat along loose rows. Finish off band ends. To mitred end of straps attach dungaree buckles, attach straight end of straps to back band of dungarees.

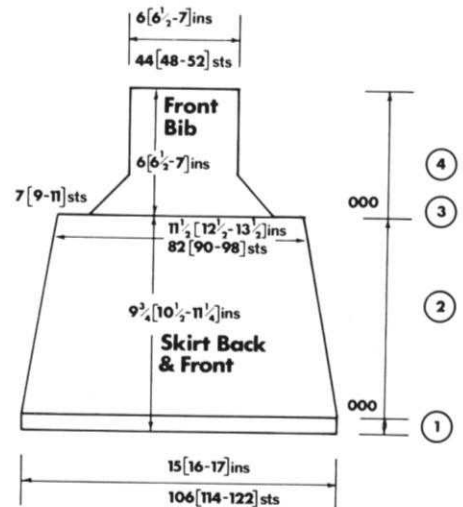

## SKIRT BACK

**Step 1.** In M. WI. C.O.B.H. 106 (114, 122) sts. Make hem as for dungarees from \* to \*. T6. Set M/c. for jacq. K. 1. C.O.R. 000.

**Step 2.** Start jacq. from graph. T7. Dec. 1 st. on each edge ev. 8 (9, 10) Rs. 12 times. (After 46 Rs. of jacq. change to T6.) K. to 106 (116, 126) Rs. Lengthen or shorten here. Thread-up sts. and take off M/c.

**SKIRT FRONT** As for back to end of step 2.

**Step 3.** C/O. 7 (9, 11) sts. at beg. next 2 Rs. C.O.R. 000.

**Step 4.** Dec. 1 st. on each edge ev. alt. R. 12 times to 24 Rs. K. to 68 (74, 80) Rs. in all. Thread-up sts. and take off M/c. Press both pieces. Join side seams.

## TO MAKE UP

**Front Band** In contrast WI. make band as dungarees.

**Back Band** In contrast WI. make band as for dungarees. Join mitres. Press seams and bands.

**Shoulder straps** In contrast WI. make straps as for dungarees and finish off in same way.



# "gypsy style" dress and blouse



Ladies' 'Gypsy' style set, consisting of 'off-the-shoulder' blouse and long patterned skirt.

## Materials

**Skirt** 15 (16, 17) balls of Colour A. Robin Crochet Courtelle. 5 balls of B. Robin Crochet Courtelle. 6 balls of C. Robin Crochet Courtelle. 3 balls of D. Robin Crochet Courtelle.

**Blouse** 2 balls of Colour A. Robin Crochet Courtelle. 12 (13, 14) balls of Colour C. Robin Crochet Courtelle.

## Measurements

To fit 32 (34, 36) in. bust.

Skirt length from waist 39 (40½, 42) ins.

Skirt waist measurement 24 (26, 28) ins.

## Tensions

7½ sts. and 12 Rs. to 1 in. on T6 over st.

## Note

\* H.C.L.'s II \* Means always take yarn around inside N. in E pos.

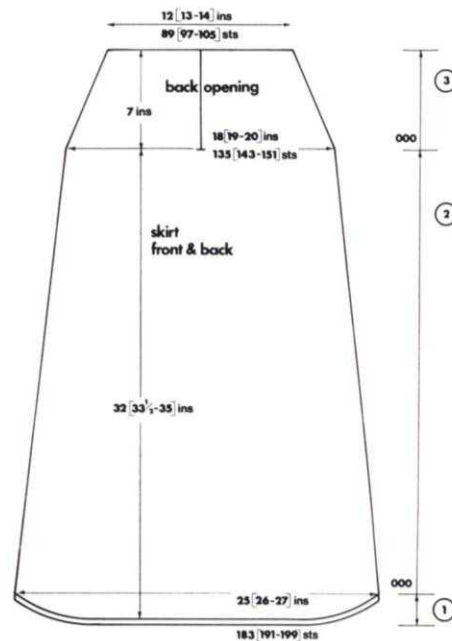

## SKIRT FRONT

1. In col. C. C.O.B.H. 183 (191, 199) sts. T5. K. 6., T7. K. 1. \* Make picot edge by trans. every alt. N. to Rt. \* M.D.E. Change to col. A. for jacq. Push 48 Ns. to E pos. at opp. end to carr. T6. K. 1. Set M/c for jacq. Push 48 Ns. to E pos. on Rt. edge K. 1. Start jacq., T7., from graph. Return 6 Ns. to C pos. at opp. end to carr. on next 16 Rs. C.O.R. 000.

2. Dec. 1 st. on each edge every 15 (16, 17) Rs. 24 (18, 12) times. Then



every 0 (15, 16) Rs. 0 (6, 12) times. \* After last R. of jacq. K. 74 (80, 86) Rs. plain on T6. On last plain R. Set M/c to jacq. K. 1. Start jacq. from graph. \* Repeat from \* to \* twice more. On last jacq. repeat, K. 43 Rs. only. After 360 (378, 396) Rs. C.O.R. 000.

3. Dec. 1 st. on each edge every 4 Rs. 11 times. Then every 3 Rs. 12 times. K. to 84 Rs. Thread-up sts. and take off M/c.

### SKIRT BACK

As for front to end of step 2.

3. Thread-up sts. to Lt. of centre and take off M/c. K. as for skirt front making decs. on Rt. edge only. Thread-up sts. and take off M/c. Replace Lt. sts. back onto M/c to Lt. of centre. K. as for skirt front making decs. on Lt. edge only. Thread-up sts. and take off M/c. Press skirt pieces. Join side seams.

### WAISTBAND

In col. C. C.O.B.H. 87 (95, 103) sts. T5. K. 42 Rs. Dec. 1 st. on Rt. edge every 5 Rs. 8 times. **At the same time** make holes on Rt. edge as follows. \* After 4 Rs. trans. the 11th st. in from Rt. edge to Rt. K. 17 Rs. Trans. the 7th st. in from Rt. edge to Rt. K. 17 Rs. Trans. the 4th N. in from Rt. edge to Rt. K. 4 Rs. \* T7. K. 1., T5. K. 42 Rs. Inc. 1 st. on Rt. every 5 Rs. 8 times. Make holes as from \* to \*. M.D.E. With Rt. side of work facing M/c, place left half of front and up to back opening onto Ns. C/o in col. B. Repeat band making shapings and holes on Lt. edge. Place Rt. half of front up to back opening onto Ns. and C/o. Crochet down back opening, working through both layers of band ends. Finish off edges of front band ends. Press bands and seams. Insert zip into opening.

### ROULEAU

In col. A. C/o 3 Ns. Press one P.B. in T2. K. until rouleau measures approx. 50 ins. C/o. Thread rouleau through holes in band as in photograph.

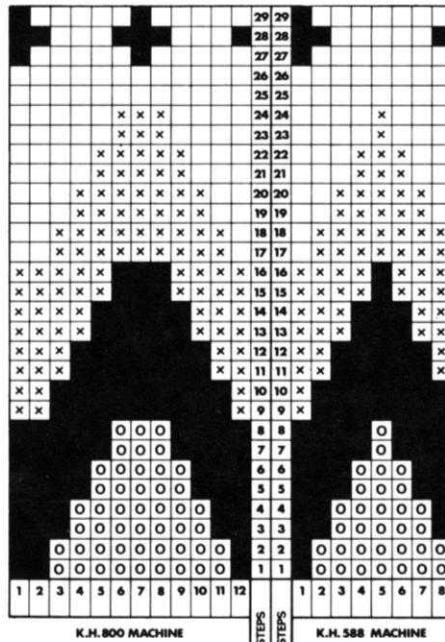
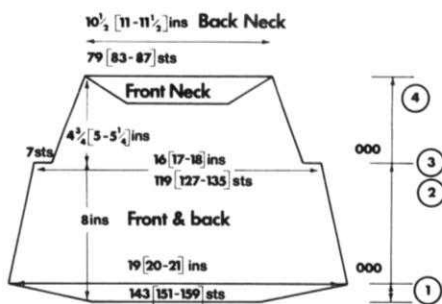

COLOUR A  
COLOUR B  
x COLOUR C  
o COLOUR D

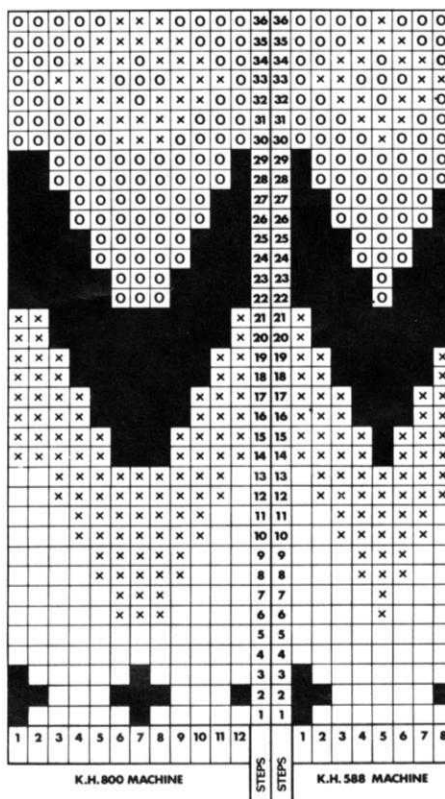

COLOUR A  
COLOUR B  
x COLOUR C  
o COLOUR D

### BLOUSE BACK

1. With W. Wl. C/o 143 (151, 159) sts. K. a few Rs. In col. C. \* H.C.L.'s II. \* Push 40 Ns. to E pos. at opp. end to carr. on next 2 Rs. Return 8 Ns. to C pos. at opp. end to carr. on next 10 Rs. C.O.R. 000.

2. Dec. 1 st. on each edge every 6 Rs. 12 times. K. to 84 Rs.

3. C/o 7 sts. at beg. next 2 Rs. C.O.R. 000.

4. Dec. 1 st. on each edge every 5 (4, 4) Rs. 4 (13, 9) times. Then every 4 (3, 3) Rs. 9 (2, 8) times. After 47 (49, 51) Rs. set M/c to jacq. K. 1. Start jacq., \* In col. A., T7. K. steps 1 to 5 from graph. Repeat once more. \* K. to 58 (60, 62) Rs. Thread-up sts. and take off M/c.

### FRONT

K. as for back to end of step 3.

4. Make decs. as for back to end of front. **At the same time**, after 28 (30, 32) Rs. Leaving 18 Ns. on Rt. edge in B pos. push rem. Ns. to E pos. \* H.C.L.'s II \* K. 2 Rs. Push 2 Rs. to E pos. on Lt. edge every alt. R. 9 times. \* Push Rt. Ns. to E pos. Push 18 Ns. on Lt. edge to C pos. Place carr. on Lt. Repeat from \* to \*. C.O.L. H.C.L.'s I. Set M/c to jacq. K. 1. C.O.R. 048 (050, 052) Rs. Start jacq. as \* to \* of back, step 4, to 58 (60, 62) Rs. Thread-up sts. and take off M/c. Press bodice pieces.

### Waist band

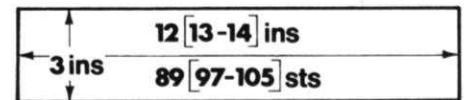

### WAISTBAND

In col. C. C.O.B.H. 89 (97, 105) sts. T5. K. 36 Rs. T7. K. 1. T5. K. 36 Rs. M.D.E. With Rt. side of work facing M/c, place bodice edge onto M/c doubling-up on some Ns. Unravel W. Wl. C/o to end. Repeat for other bodice piece.

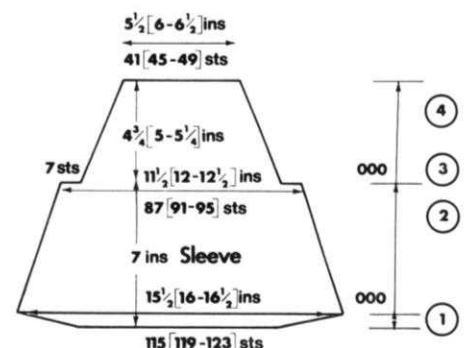



## SLEEVES

1. With W. Wl. C/o 115 (119, 123) sts. K. a few Rs. In col. C. \* H<sub>1</sub>C.L.'s II. \* Push 21 Ns. to E pos. at opp. end to carr. on next 2 Rs. Return 7 Ns. to C pos. at opp. end to carr. on next 6 Rs. **On last row** set M/c to jacq. K. 1. C.O.R. 000.

2. Start jacq. as \* to \* of back step 4. Dec. 1 st. on each edge every 6 Rs. 4 times. Then every 5 Rs. 10 times. K. to 78 Rs.

3. C/o 7 sts. at beg. next 2 Rs. C.O.R. 000.

4. Dec. 1 st. on each edge every 4 Rs. 8 (10, 12) times. Then every 3 Rs. 8 (6, 4) times. After 47 (49, 51) Rs. set M/c to jacq. K. 1. Start jacq. as \* to \* of back step 4. K. to 58 (60, 62) Rs. Thread-up sts. and take off M/c. Repeat sleeve. Press both sleeves.

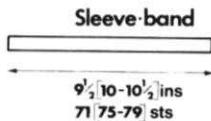

## SLEEVE BAND

In col. A. C.O.B.H. 71 (75, 79) sts. \* T5. K. 4. T7. K. 1. Make picot edge as from \* to \* of skirt front step 1. T5. K. 5. M.D.E. \* With right side of work facing M/c, place sleeve edge onto M/c, doubling-up on some Ns. Unravel W. Wl. C/o in col. C. Repeat for other sleeve. Press bodice and sleeve bands. Join sleeve and bodice pieces at raglans. Press seams.

## FRONT AND SLEEVE NECK BAND

In col. A. C.O.B.H. 155 (167, 179) sts. Make band as for sleeve band from \* to \*. With Rt. side of work facing M/c., place sleeve to 39 (43, 47) Ns. Place front to 77 (81, 85) Ns. and sleeve to rem. Ns. C/o. in col. C.

## BACK BAND

In col. A. C.O.B.H. 77 (81, 85) Ns. Make band as before and C/o in same way.

## TO MAKE UP

Join side seams. Insert  $\frac{1}{4}$  in. by desired length elastic into sleeve bands and secure ends. Join sleeve seams. Join neckband seams. Press all seams and bands.

## ROULEAU

In col. A. Cast on 2 Ns. TO. Press one PB. in K. until rouleau measures approx. 40 ins. C/o. Thread rouleau into neckband tying at front.

# Jones home knitting tuition

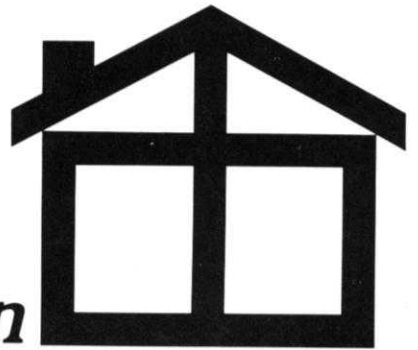

There are twelve easy to follow lessons, leading you step by step from basic knitting right through to knitwear design and all packaged in a beautiful binder that you will be able to keep for many years to come. Apart from being the most comprehensive tuition available on knitting machines – this Jones postal course has many other advantages that appeal greatly to our customers. You are able to learn to knit at your own pace with nobody looking over your shoulder or hurrying you on to the next step. You can take out the machine and pick up the course exactly when you feel like it and all in the comfort of your own home. Should you require help you can write and ask the experts who are always there. Later you may wish to refresh your memory on certain points and of course the lessons are always there for you to refer to.



**INCLUDED WITH THE COURSE  
IS WOOL SUFFICIENT TO  
KNIT THREE GARMENTS!**

# for 585, 588 and 800 machines »

# £12.50









hand to E pos. Instead of changing H.C.L.'s to 1 as on graph push Ns. to C pos. On coat bodice and sleeves also work trans. by hand. For pull up patt. slide dial is on I unless stated otherwise.

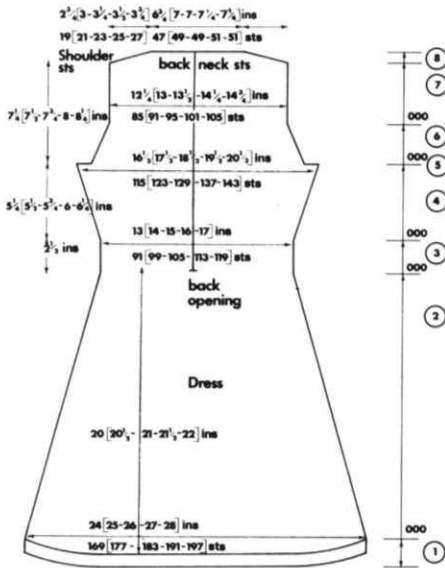

**DRESS BACK**

**1. Hem** In 4 ply cast on 169 (177, 183, 191, 197) sts. T6. K. 15 Rs. T7. K. 1 R. C.O.R. 000. Start pull up patt. (I) from graph (see note). Always taking yarn round inside N. in E pos. H.C.L.'s II push 42 Ns. to E pos. at opp. end to carr. on next 2 Rs. Return 7 Ns. to C pos. at opp. end to carr. on next 12 Rs. C.O.R. 000.

**2.** Dec. 1 st. on each edge every 7 Rs. 22 (28, 34, 39) times. Then every 6 Rs. 17 (11, 5, 0) times. For last size only dec. 1 st. every 8 Rs. 7 times, then every 7 Rs. 32 times. K. 256 (262, 268, 274, 280) Rs. C.O.R. 000.

**3.** Thread up sts. to Lt. centre and take off M/c. K. 34 Rs. C.O.R. 000.

**4.** For first size only, inc. 1 st. on Rt. edge at 000. Inc. 1 st. on Rt. edge every 6 Rs. 12 times K. 70 (74, 78, 82, 86) Rs.

**5.** K. 2 Rs. 000. (5) C/o 5 (6, 7, 8, 9) sts.

**6.** Dec. 1 st. on Rt. edge every 4 Rs. 10 times to 40 Rs. C.O.R. 000.

**7.** K. 56 (60, 64, 68, 72) Rs.

**8. Shoulder** K. 1 R. C.O.L. H.C.L.'s II. Push 4 (4, 4, 5, 5) Ns. to E pos. on Rt. edge every alt. R. 1 (3, 5, 1, 3) times. Then push 3 (3, 3, 4, 4) Ns. to E pos. on Rt. edge every alt. R. 5 (4, 1, 5, 3) times. H.C.L.'s I. K. 1. C/o shoulder, thread up B.N. sts. and take

off M/c. Place thread up sts. back onto M/c. to Lt. of centre.

**4.** As for back, shaping on Lt. edge.

**5.** K. 1. C/o 5 (6, 7, 8, 9) sts. K. 1. C.O.R. 000.

**6.** Shape on Lt. edge.

**7.** As before.

**8. Shoulder** As before shaping on Lt. edge.

**FRONT**

As for back for steps 1-3.

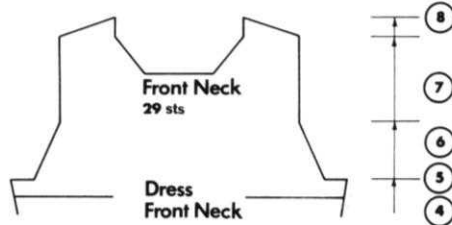

**Front Neck**

As for back, omitting back opening to step 7.

**4. Dart** K. 58 (62, 66, 70, 74) Rs. For last three sizes only, always taking yarn round inside N. in E pos. H.C.L.'s II, push 36 (40, 42) Ns. to E pos. at opp. end to carr. on next 2 Rs. Return 9 (8, 7) Ns. to C pos. on next 8 (10, 12) Rs. K. to 70 (74, 78, 82, 86) Rs.

**7.** K. 28 (30, 34, 34, 38) Rs. Thread up centre 29 sts. and take off M/c. Thread up Lt. Ns. and take off M/c. \* On neck edge dec. 1 st. every 3 Rs. 9 (10, 10, 11, 11) times to 19 (21, 23, 25, 27) sts. K. to 56 (60, 64, 68, 72) Rs.

**8. Shoulder** As for back \*.

Replace Lt. Ns. and repeat from \* to \*.

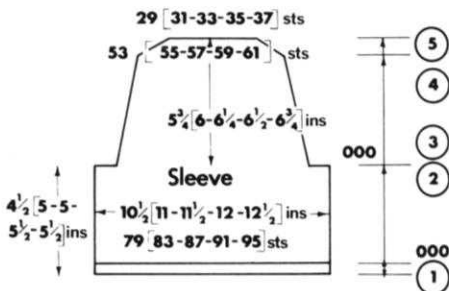

**SLEEVE**

**1.** In 4 ply cast on 79 (83, 87, 91, 95) sts. \* T5. K. 6. T7. K. 1 make picot edge by trans. every alt. N. to Rt. T5. K. 7. M.D.E. \* C.O.R. 000.

**2.** T6. K. 42 (48, 48, 54, 54) Rs.

**3.** C/o 5 (6, 7, 8, 9) sts. at beg. next 2 Rs. C.O.R. 000.

**4.** Dec. 1 st. on each edge every 7 Rs. 8 times. K. 56 Rs.

**5. Sleeve top** Always taking yarn round inside N. in E pos. H.C.L.'s II, push 4 (3, 3, 2, 2) Ns. to E pos. at opp. end to carr. on next 4 (4, 4, 6, 10) Rs. Then 4 (3, 2, 2, 1) Ns. to E pos. on next 2 (4, 6, 6, 4) Rs. Push Lt. Ns. to C pos. K. 1. H.C.L. I. K. 1. C/o. Repeat sleeve. Press back and front. Join shoulders.

**COLLAR**

C.O.B.H. 137 (147, 147, 157, 157) sts. Make hem as for sleeve from \* to \*. T6. K. 1. C.O.L. 000. H.C.L.'s II, always taking yarn round inside N. in E pos. push 56 Ns. to E pos. at opp. end to carr. on next 2 Rs. Then push 4 Ns. back to C pos. at opp. end to carr. on next 28 Rs. C.O.L. 030. Dec. 1 st. on each edge every alt. R. 10 times. K. to 52 Rs. Starting from centre double up on every alt. N. 15 (17, 17, 19, 19) times on each half to 107 (113, 113, 119, 119) sts. With plain side of work facing M/c., place 1/2 B.N. to first 24 (25, 25, 26, 26) Ns., place side neck to next 15 (17, 17, 19, 19) sts. and front neck to 29 Ns. C/o up to this point. Place side neck to 15 (17, 17, 19, 19) Ns. and 1/2 B.N. to rest of Ns. C/o to end. Press sleeves and sew tops into armholes, gathering slightly. Press seams. Close side and sleeve seams. Press seams and collar. Crochet down back opening. Sew in zip. Turn up hem and slip-st. in place. Press hem.

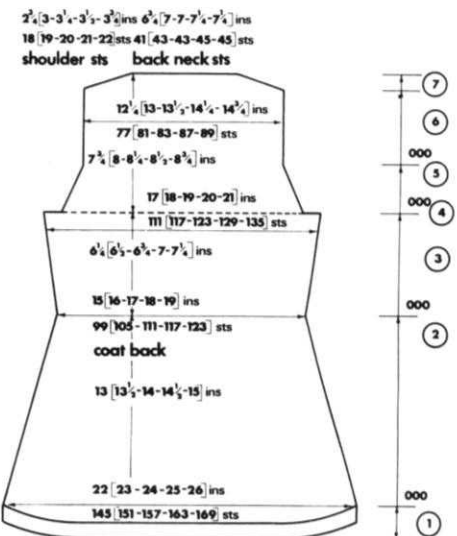

**COAT BACK**

**1. Hem** In D.K. cast on 145 (151, 157, 163, 169) sts. T7. K. 11. T9. K. 1. C.O.R. 000. T8. Always taking yarn







round inside N. in E pos. H.C.L.'s on II push 35 Ns. to E pos. at opp. end to carr. on next 2 Rs. Return 7 Ns. to C pos. at opp. end to carr. on next 10 Rs. C.O.R. 000.

**2.** T8. Dec. 1 st. on each edge every 6 Rs. 0 (5, 9, 13, 17) times. Then every 5 Rs. 23 (18, 14, 10, 6) times. K. 116 (120, 124, 128, 132) Rs. C.O.R. 000.

**3.** Inc. 1 st. on each edge every 9 (10, 10, 10, 11) Rs. 6 times. K. 60 (62, 64, 66, 68) Rs.

**4.** C/o 7 (8, 10, 11, 13) sts. at beg. next 2 Rs. C.O.R. 000.

**5.** After armhole start pull up patt. (2). T9. Dec. 1 st. on each edge every 4 Rs. 10 times K. 40 Rs. C.O.R. 000.

**6.** K. 54 (56, 58, 60, 62) Rs.

**7. Shoulder** H.C.L.'s II push 2 (3, 4, 5, 6) Ns. to E pos. at opp. end to carr. on next 2 Rs. Then push 4 Ns. to E pos. on next 8 Rs. Push Lt. Ns. to C pos. K. 1. H.C.L. I. K. 1. C/o shoulders. Thread up back neck sts. and take off M/c.

29		Pull-up Patt 2								
28									I	→
27									"	→
26									"	→
25				■		■			III	→
24									"	→
23									"	→
22									"	→
21				■		■			III	→
20									"	→
19									"	→
18									"	→
17									"	→
16			■			■			III	→
15									"	→
14									"	→
13									"	→
12									"	→
11									"	→
10				■		■			III	→
9									"	→
8									"	→
7									"	→
6									"	→
5									"	→
4									"	→
3									"	→
2									"	→
1									"	→
	STEPS	1	2	3	4	5	6	7	8	
		K.H. 588 MACHINE								
										I. H.C.L. II II. H.C.L. I III. C/O C.O.R.

## NECKBAND

Cast on 159 (167, 175, 183, 191) sts. \* T7. K. 6. Inc. 1 st. on each edge every alt. R. 3 times. T9. K. 1. T7. K. 6. Dec. 1 st. on each edge every alt. R. 3 times. \* M.D.E. With purl side of work facing M/c., place front neck to 16 (17, 19, 21, 22) sts., side neck to 43 (45, 47, 48, 51) Ns. and B.N. to 41 (43, 45, 45) Ns. C/o. Place S.N. to 43 (45, 47, 48, 51) and F.N. to 16 (17, 19, 21, 22) Ns. C/o to end.

## FRONT BANDS

Cast on 129 (134, 139, 144, 149) sts. Make band as for neck, from \* to \*, work incs. and decs. on one edge only. Place front to band, turn back hem and place to 8 sts. C/o. Repeat band, work incs. on opp. edge. C/o.

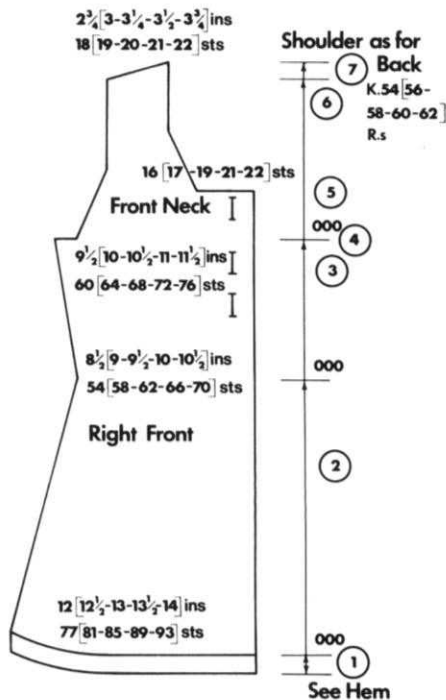

## RIGHT FRONT

**1. Hem** In D.K. cast on 77 (81, 85, 89, 93) sts. to Lt. of centre. T7. K. 11. T9. K. 1. Always taking yarn round inside N. in E pos. H.C.L.'s II, push 35 Ns. to E pos. on Lt. edge. K. 2 Rs. Return 7 Ns. to C pos. on Lt. edge every alt. R. 5 times. C.O.R. 000.

**2.** As for back shaping on Lt. edge only. C.O.R. 000.

**3. Buttonholes** After 22 (24, 26, 28, 30) Rs. \* H.C.L.'s II. Push Lt. Ns. to E pos. leaving 7 Ns. in B pos. at centre M/c. Break off yarn. Push Lt. Ns. to C pos. and push centre 7 Ns. to E pos. K. 10 Rs. Place C.O.R. Set row counter back 10 Rs. \* H.C.L. I. K. 14 Rs. Repeat from \* to \*. Work dart.

## Dart

At the same time as working shaping and buttonholes for **last three sizes** only, after 56 (58, 60, 62, 64) Rs. work dart. Always taking yarn round inside N. in E pos. H.C.L.'s II push 36 (40, 42) Ns. to E pos. on Lt. edge. K. 2. Return 9 (8, 7) Ns. to C pos. on Lt. edge every alt. R. 4 (5, 6) times. K. to 60 (62, 64, 66, 68) Rs.

**4.** K. 1. C/o 7 (8, 10, 11, 13) sts. on Lt. K. 1. C.O.R. 000.

**5.** After armhole start pull up patt. (2). S.L. D. on 2. Make decs. on Lt. edge as for back. After 10 Rs. make buttonhole as \* to \*. K. 6 Rs. to front neck.

## FRONT NECK

After 28 Rs. on centre front, C/o 16 (17, 19, 21, 22) sts. Then dec. 1 st. every 4 Rs. 9 times to 18 (19, 20, 21, 22) sts. Cont. to end step 6.

**6.** K. 54 (56, 58, 60, 62) Rs.

**7.** Shoulder as for back.

## LEFT FRONT

As for right, reverse all shapings. Omit buttonholes. S.L. D. on 7, for pull up patt. Press back and fronts. Join shoulders.

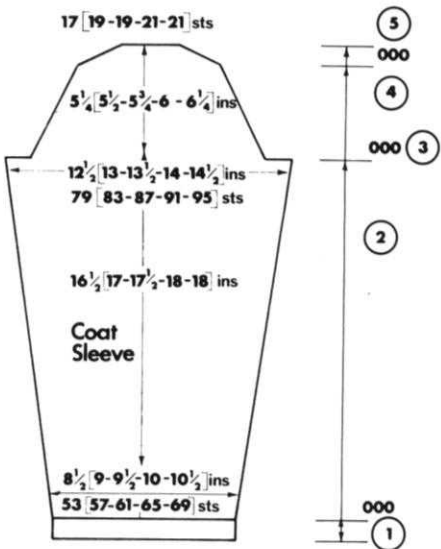

## COAT SLEEVE

**1. Hem** Cast on 53 (57, 61, 65, 69) sts. in D.K. T7. K. 11. T9. K. 1. C.O.R. 000.

**2.** T8. Inc. 1 st. on each edge every 12 Rs. 13 times. K. 158 (162, 166, 170, 170) Rs.

**3.** C/o 7 (8, 10, 11, 13) sts. at beg. next 2 Rs. C.O.R. 000.

**4.** Start pull up patt. (2) after armhole. T9. Dec. 1 st. on each edge every 5 Rs. 0 (2, 4, 6, 8) times. Then every 4 Rs. 13 (11, 9, 7, 5) times. K. to 52 (54, 56, 58, 60) Rs. C.O.R. 000.

**5.** H.C.L.'s II push 2 Ns. to E pos. at opp. end to carr. on next 10 Rs. Then 1 N. to E pos. on next 2 Rs. Push Lt. Ns. C pos. K. 1. H.C.L. I. K. 1. C/o. Repeat sleeve. Press. Sew tops into armholes. Close side and sleeve seams. Turn back hems on sleeves and coat, slip-st. in place. Finish off edges of bands. Press all seams and bands. Finish buttonholes, sew on buttons to correspond with holes.



# Jones

*all around your home*

## THIS CHRISTMAS

Everyone's making a bee line for 2 new Carousel cassette recorders from Jones, but then that's not surprising because in them we offer the same quality and value for money that is always associated with Jones products.

So here's a special Christmas offer to you, an already valued customer. Big, big cash savings on both these recorders which amount to us offering the units to you at trade prices.

**But hurry this is a once only offer!**

# SAVE £22.70      SAVE £12.50

on model 270 cassette recorder and radio – all in one. Recommended retail price £47.95. Special offer price **£25.25** + 50p postage and packing.

- AM/FM radio ● Super sensitive built-in condenser microphone ● Automatic level control ● Tape auto stop ● Push button controls ● Sliding volume and tone controls ● Built-in telescopic FM aerial ● Battery/mains operation

Supplied complete with AC line cord and personal earphone.

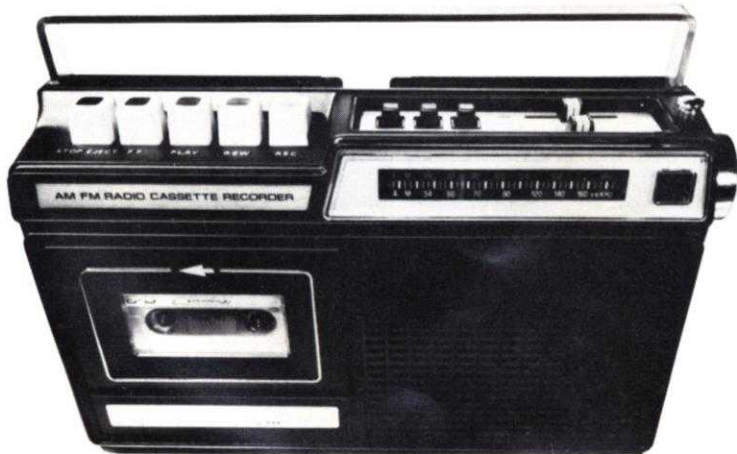

Make sweet sweet music this Christmas with a Carousel cassette recorder from Jones. **But hurry**, be sure to send your order off today together with your cheque or postal order and we will despatch the units by return.

**To: Stitchin' Time Special Offer (Cassette Recorders)**  
Jones Sewing Machine Co. Ltd, Britannia House,  
964 High Road, Finchley, London N12 8LE

on model 250 cassette recorder. Recommended retail price £26.95. Special offer price **£15.45** + 50p postage and packing.

- Super sensitive built-in condenser microphone ● Automatic level control ● Tape auto stop ● Push button controls ● Sliding volume control ● Battery/mains operation

Supplied complete with AC line cord and personal earphone.

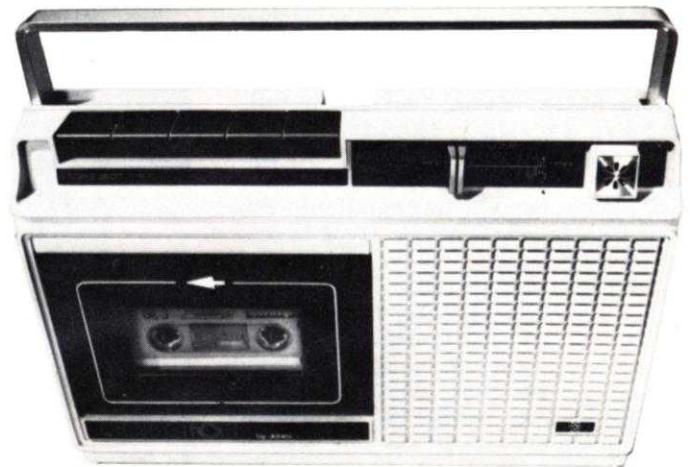

Please supply one model 270 cassette recorder at £25.25 + 50p postage and packing.

Please supply one model 250 cassette recorder at £15.45 + 50p postage and packing.  
Delete item not required

I enclose my cheque/postal order for the required amount.

Please send to

Name \_\_\_\_\_

Address \_\_\_\_\_

\_\_\_\_\_

OFFER APPLIES TO U.K. MEMBERS ONLY.







dec. 1 st. at this point. Then for all sizes dec. 1 st. ev. 6 Rs. 16 (16, 16, 17) times. T8. K. 8 Rs. patt. (reversing colours). Change to T6. K. to 110 Rs. C.O.R. 000.

**Step 3.** On Lt. edge dec. 1 st. ev. R. 32 (34, 36, 38) times. K. to 34 (36, 38, 40) Rs. (3 sts.) C/O.

**Ribbers** In colour A. Cast on 57 (61, 65, 69) sts. as 1 x 1 rib. K. as \* to \* back, step 1.

**Single bed M/cs.** C.O.B.H. 56 (60, 64, 68) sts. K. as \* to \* back. With right side of work facing M/c., place waist edge of front evenly onto Ns. and C/O. Repeat front reversing all shapings.

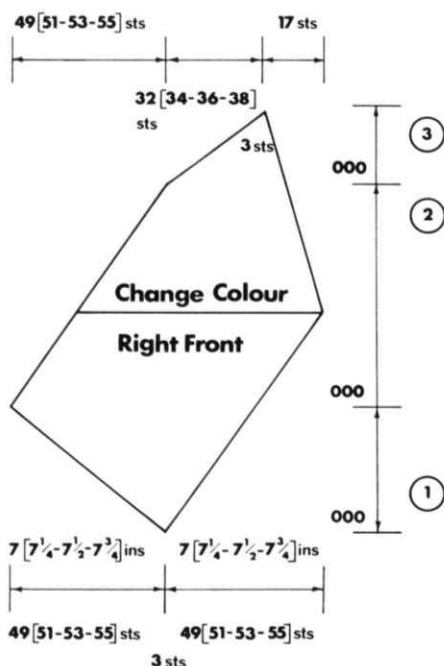

### SLEEVE

**Step 1. Ribbers** In colour A. Cast on 53 (57, 61, 65) sts. as 1 x 1 rib. K. as \* to \* of back, step 1. Dec. 1 st.

**Single bed M/cs.** C.O.B.H. 52 (56, 60, 64) sts. K. as \* to \* back. T6. K. 1. C.O.R. 000.

**Step 2.** T6. Inc. 1 st. on each edge ev. 9 Rs. 17 times. After 154 Rs. T8. K. 8 Rs. patt. from graph. T6. K. 4 Rs. To 166 Rs. C.O.R. 000.

**Step 3.** Change to colour B. Dec. 1 st. on each edge at 000. Then ev. 7 Rs. 14 times. After 4 Rs. T8. K. 8 Rs. patt. Change to T6. After 58 (62, 66, 70) Rs. Thread-up sts. to Lt. centre and take off M/c. On Lt. (centre) edge dec. 1 st. ev. 5 Rs. 9 times. After 98 (102, 106, 110) Rs. K. 1. C.O.L. \* H.C.L.'s II \* Push 7 (7, 8, 9) Ns. to E pos. at opp. end to carr. K. 2 Rs. Then push 6 (7, 8, 8) Ns. to E pos. K. 2 Rs. H.C.L. I. K. 1. C/O. Replace thread-up sts. back onto M/c. C.O.R. 058 (62, 66, 70). At the same time as working

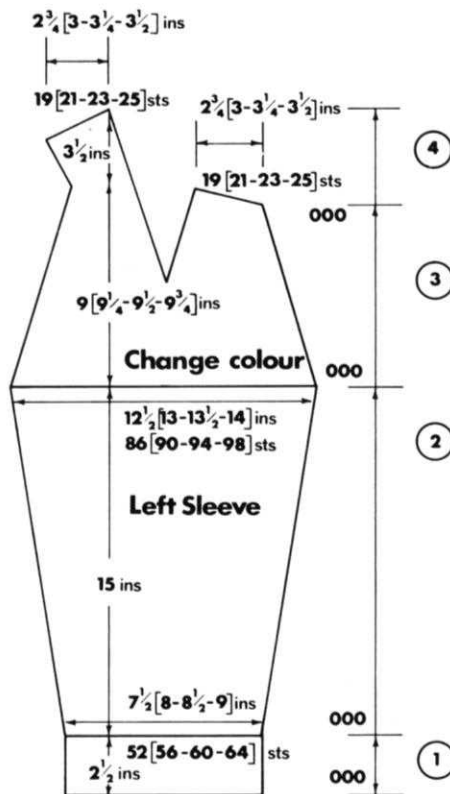

Lt. edge decs. dec. 1 st. on Rt. edge ev. 5 Rs. 12 times. K. to 98 (102, 106, 110) Rs. C.O.R. 000.

**Step 4.** Cont. decs. on Rt. edge. At the same time on Lt. edge inc. 1 st. at 000. Then ev. 3 Rs. 6 times to 22 Rs. C.O.R. \* H.C.L.'s II \* Push 3 Ns. to E pos. on Lt. edge ev. alt. R. 3 (5, 7, 7) times. Then 2 Ns. to E pos. 4 (2, 0, 0) times. H.C.L. I. K. 1. C/O.

### TO MAKE UP

Press all pieces. Join sleeves together at back neck. Join sleeves and back. Join fronts to sleeves at raglans. Close shoulder darts. Press all seams. Join side and sleeve seams.

### BUTTONHOLE BAND

**Ribbers** In colour A. Cast on 20 sts. as 'all-needle' rib 1 st. N. on Lt. on M.B., last N. on rib bed. T0/0. K. 2 Rs. Tub. C.O.R. 000. T2/2. K. 2 Rs. \* Buttonhole. with spare strand of contrast Y., by hand K. centre 5 sts. \* Leaving space of 34 Rs. between holes make 6 buttonholes as \* to \*. After 81 Rs. \* Change to colour B. K. 2 Rs. Change to A. K. 8 Rs. Change to B. K. 8 Rs. Change to A. K. 2 Rs. Change to B. to end. K. to 344 Rs. Trans. Ns. to M.B. C/O. \* Repeat for button band omitting holes. After 80 Rs. repeat as \* to \*.

**Single bed M/cs.** In colour A. C.O.B.H. 18 sts. As for ribbers. T5. Making buttonholes over Ns. 4, 5 and 6 from each end. Sew front bands in pos. Turn st.st. band to inside and

slip-st. in place. Finish off buttonholes. Press band seams. Sew on buttons to correspond with holes.

### VEST BACK

**Step 1. Ribbers** In colour A. Cast on 117 (125, 133, 141) sts. as 1 x 1 rib. K. as \* to \* of cardigan back. Dec. 1 st.

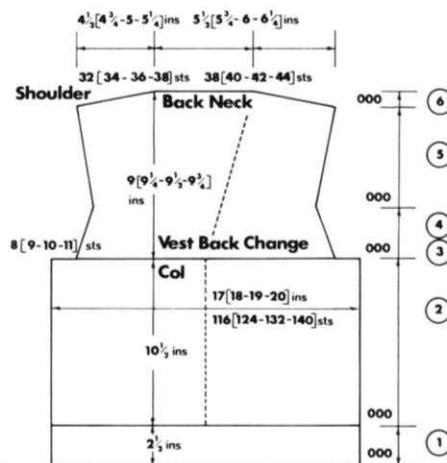

**Single bed M/cs.** C.O.B.H. 116 (124, 132, 140) sts. K. as \* to \* of cardigan. T6. K. 1. C.O.R. 000.

**Step 2.** K. 114 Rs. straight. After 78 Rs. start patt. from graph. \* T8. K. 8 Rs. of patt. T6. K. 4 Rs. of st.st. \* Repeat twice more.

**Step 3.** Change to colour B. C/O. 8 (9, 10, 11) sts. at beg. next 2 Rs. C.O.R. 000.

**Step 4.** K. 2 Rs. st.st. Then K. three repeats of patt. as \* to \*. At the same time dec. 1 st. on each edge ev. 4 Rs. 8 times. K. to 34 Rs. C.O.R. 000.

**Step 5.** Inc. 1 st. at 000. Then ev. 8 Rs. 8 times. K. to 66 (68, 70, 72) Rs. C.O.R. 000.

**Step 6.** \* H.C.L.'s II \* Push 6 Ns. to E pos. at opp. end to carr. on next 8 Rs. Then 4 (5, 6, 7) Ns. to E pos. on next 4 Rs. Push Ns. on Lt. to C pos. K. 1. H.C.L. I. K. 1. C/O. shoulders. Thread-up Back Neck sts.

### RIGHT FRONT

**Step 1.** In colour A. Cast on 3 sts. T6. On Rt. edge inc. 1 st. ev. alt. R. 42 (44, 46, 48) times. K. to 86 (90, 94, 98) Rs. At the same time on Lt. edge inc. 1 st. ev. R. 40 times. Then ev. alt. R. 8 (10, 12, 14) times. K. to 58 (62, 66, 70) Rs. C.O.R. 000.

**Step 2.** Start patt. from graph. K. sequence as for back. (Steps 2 and 3.) On Lt. edge dec. 1 st. at 000. Then ev. alt. R. 25 (29, 33, 37) times. Then ev. 3 Rs. 12 (10, 8, 6) times. On Rt. edge (after 86 (90, 94, 98) Rs.) dec. 1 st. ev. R. 10 times. Then inc. 1 st. ev. 4 Rs. 8 times. K. to 34 Rs. Inc. 1 st. at this point. Then inc. 1 st. ev. alt. R. 17 times. Then ev. R. 10

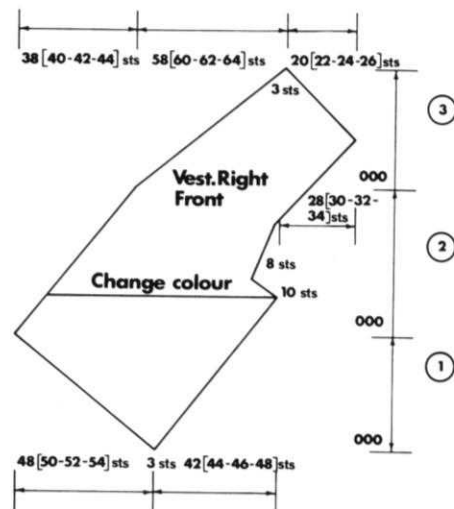

(12, 14, 16) times. On Lt. edge after 88 (90, 92, 94) Rs. C.O.R. 000.

**Step 3.** Dec. 1 st. on Lt. edge at 000. Then ev. R. 46 (48, 50, 52) times. Then ev. alt. R. 11 times. On Rt. edge (after 46 (48, 50, 52) Rs.) dec. 1 st. at this point. Then ev. R. 0 (2, 4, 6) times. Then ev. alt. R. 19 times. To 40 (42, 44, 46) Rs. C/O. rem. 3 sts. Repeat for Lt. Front reversing **all** shapings.

#### TO MAKE UP

Press all pieces. Join fronts together.

#### FRONT RIB

K. as for back from \* to \*. With Rt. side of work facing M/c. place front evenly onto Ns. and C/O. Join shoulders. Press all seams.

#### NECKBAND

**Ribbers** Cast on in colour B. 143 (149, 155, 161) sts. as 1 x 1 rib. TO/O. K. 2 Rs. Tub. T2/2. Inc. 1 st. on each edge ev. alt. R. 6 times. Trans. Ns. to M.B.

**Single bed M/cs.** C.O.B.H. 156 (162, 168, 174) sts. T5. Dec. 1 st. on each edge ev. alt. R. 6 times. T7. K. 1. T5. Inc. 1 st. on each edge ev. alt. R. 6 times. M.D.E. With Rt. side of work facing M/c. Place side neck to 59 (61, 63, 65) sts. Place back neck to 38 (40, 42, 44) Ns. and rest of neck to rem. Ns. C/O. to end.

#### ARMBANDS

**Ribbers** In colour B. Cast on 125 (129, 133, 137) sts. as 1 x 1 rib. TO/O. K. 2 Rs. Tub. T2/2. Inc. 1 st. on each edge ev. alt. R. 4 times. Trans. Ns. to M.B.

**Single bed M/cs.** C.O.B.H. 134 (138, 142, 146) sts. T5. Dec. 1 st. on each edge ev. alt. R. 4 times. T7. K. 1. T5. Inc. 1 st. on each edge ev. alt. R. 4 times. M.D.E. With Rt. side of work facing M/c. Place armhole evenly onto Ns. and C/O. to end. Repeat. Join side seams. Finish front band mitre. Press all seams and bands.



# woven lace patterned coat

**Materials** 13 (14, 16, 18, 20) balls of Hayfield Fourmost 4 ply wool/nylon. 11 (12, 14, 16, 18) balls of Hayfield Croft Thickerknit. 3 shaft buttons.

## Measurements

To fit 22 (24, 26, 28, 30) ins. chest.  
 Finished measurement 23 (25, 27, 29, 31) ins. chest.  
 Sleeve seam 11 (12½, 14, 15½, 17) ins. (including edging).  
 Length from back neck 23 (25, 26¾, 29, 31) ins. (including edging).

## Tension

6 sts. and 9 Rs. to 1 in. on T8 over weave/lace patt.

## Note

\* H.C.L.'s II \*—Always take Y. around inside N. in E pos.

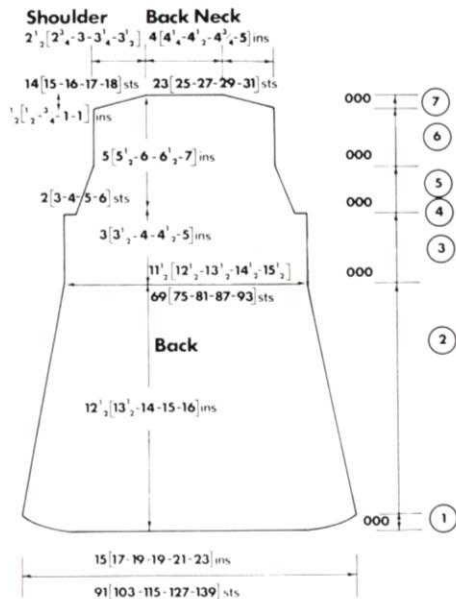

## COAT BACK

**Step 1.** With 4 ply. C.O.B.H. 91 (103, 115, 127, 139) sts. (extra st. to Rt. of centre). T6. K. 2 Rs. C.O.R. 000. Start weave-patt. from graph. T8. Slide dial on 1. \* H.C.L.'s II \* Push 16 (16, 20, 20, 24) Ns. to E pos. at opp. end to carr. on next 2 Rs. Then push 4 (4, 5, 5, 6) Ns. back to C pos. at opp. end to carr. on next 8 Rs. C.O.R. 000.

**Step 2.** Dec. 1 st. on each edge ev. 11 (9, 8, 7, 7) Rs. 4 (12, 11, 10, 12) times. Then ev. 10 (8, 7, 7, 6) Rs. 7 (2, 6, 10, 11) times. To 114 (124, 130, 140, 150) Rs. C.O.R. 000.

**Step 3.** K. 28 (32, 36, 40, 44) Rs. straight. Lengthen or shorten here.

**Step 4.** C/O. 2 (3, 4, 5, 6) sts. at beg. next 2 Rs. C.O.R. 000.

**Step 5.** Dec. 1 st. on each edge ev. 3 Rs. 7 times. K. to 22 Rs. C.O.R. 000.

**Step 6.** K. 24 (28, 32, 36, 40) Rs. straight. C.O.R. 000.

**Step 7.** \* H.C.L.'s II \* Push 5 (5, 4, 4,



4) Ns. to E pos. at opp. end to carr. on next 4 (4, 4, 4, 6) Rs. Then 4 (5, 4, 3, 3) Ns. to E pos. on next 2 (2, 4, 6, 4) Rs. Push Ns. on Lt. back to C pos. K. 1. H.C.L. I. K. 1. C/O. to end.

## RIGHT FRONT

**Step 1.** With 4 ply. C.O.B.H. 20 (25, 32, 37, 44) sts. to Rt. of centre. T6. K. 2 Rs. C.O.R. Start weave-patt. from graph. Slide dial on 6. T8. On Lt.

### 1/2 Front Neck

2 [2 1/8 - 2 1/4 - 2 3/8 - 2 1/2] ins

12 [12-14-14-16] sts

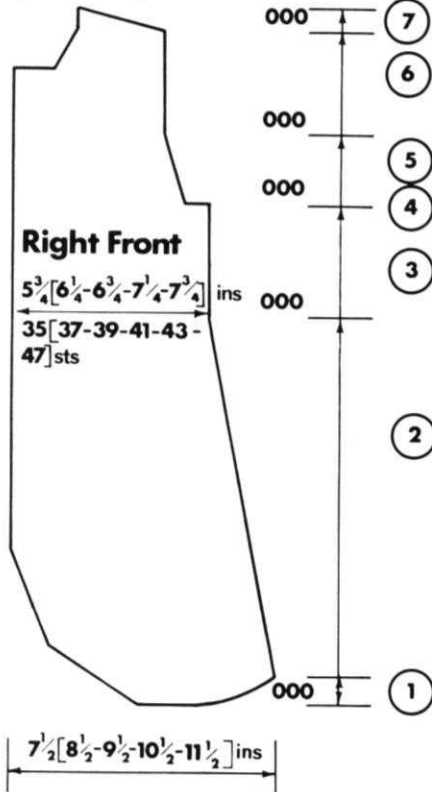

### Right Front

5 3/4 [6 1/4 - 6 3/4 - 7 1/4 - 7 3/4] ins

35 [37-39-41-43-47] sts

7 1/2 [8 1/2 - 9 1/2 - 10 1/2 - 11 1/2] ins

edge \* inc. 1 st. ev. R. 18 times. Then ev. 4 Rs. 8 times. \* **At the same time** K. 1. C.O.L. \* H.C.L.'s II \* Push 16 (16, 20, 20, 24) Ns. to E pos. on Rt. edge. K. 2 Rs. Then push 4 (4, 5, 5, 6) Ns. back to C pos. ev. alt. R. 4 times. \* K. 1. C.O.R. 000.

**Steps 2 & 3.** As for back shaping on Rt. side seam only.

**Step 4.** On Rt. edge C/O. 2 (3, 4, 5, 6) sts. K. 2 Rs. C.O.R. 000.

**Step 5.** As for back shaping on Rt. edge only.

**Step 6.** After 10 (14, 16, 20, 22) Rs. straight start front neck. K. 1. C.O.L. C/O. 6 (6, 7, 7, 8) sts. on Lt. edge. K. 1. C.O.R. Dec. 1 st. on Lt. edge ev. alt. R. 6 (6, 7, 7, 8) times. To 24 (28, 32, 36, 40) Rs. C.O.R. 000.

**Step 7.** K. 1. \* H.C.L.'s II \* Push 5 (5, 4, 4, 4) Ns. to E pos. on Rt. edge ev. alt. R. 2 (2, 2, 2, 3) times. Then 4 (5, 4, 3, 3) Ns. to E pos. 1 (1, 2, 3, 2) times. Push Ns. back to C pos. K. 1. C/O.

### LEFT FRONT

**Step 1.** With 4 ply. C.O.B.H. 20 (25, 32, 37, 44) sts. to Lt. of centre. T6. K. 2 Rs. C.O.R. Start weave-patt. from graph. S.D. on 3. T8. On Rt. edge inc. as for back from \* to \* of front. **At the same time** On Lt. edge

shape as \* to \* of Rt. front. C.O.R. 000.

**Steps 2 & 3.** As for back shaping on Lt. edge only.

**Step 4.** K. 1. C/O. 2 (3, 4, 5, 6) sts. on Lt. edge. K. 1. C.O.R. 000.

**Step 5.** As for back shaping on Lt. edge only.

**Step 6.** After 10 (14, 16, 20, 22) Rs. On Rt. edge C/O. 6 (6, 7, 7, 8) sts. K. 2 Rs. Dec. 1 st. on Rt. edge ev. alt. R. 6 (6, 7, 7, 8) times. To 24 (28, 32, 36, 40) Rs. C.O.R. 000.

**Step 7.** \* H.C.L.'s II \* Push 5 (5, 4, 4, 4) Ns. to E pos. on Lt. edge ev. alt. R. 2 (2, 2, 2, 3) times. Then 4 (5, 4, 3, 3) Ns. to E pos. 1 (1, 2, 3, 2) times. Push Ns. on Lt. to C pos. K. 1. C/O.

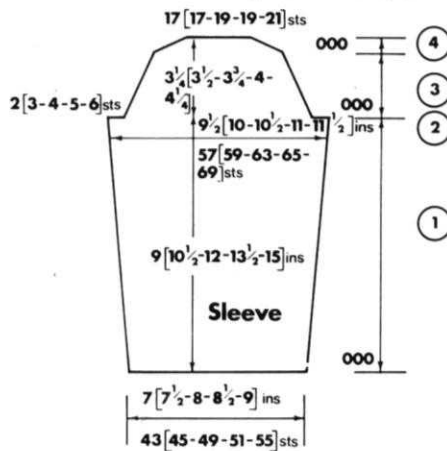

### SLEEVES (Knit 2)

**Step 1.** In 4 ply. C.O.B.H. 43 (45, 49, 51, 55) sts. (extra st. to Rt. centre). T6. K. 2 Rs. C.O.R. 000. Start weave-patt. from graph. S.D. on 1. T8. Inc. 1 st. on each edge ev. 11 (13, 15, 17, 19) Rs. 7 times. K. to 80 (94, 108, 122, 136) Rs.

**Step 2.** C/O. 2 (3, 4, 5, 6) sts. at beg. next 2 Rs. C.O.R. 000.

**Step 3.** Dec. 1 st. on each edge ev. 4 Rs. 7 times. To 28 Rs. C.O.R. 000.

**Step 4.** \* H.C.L.'s II \* Push 6 (4, 3, 3, 2) Ns. to E pos. at opp. end to carr. on next 2 (4, 6, 2, 10) Rs. Then 5 (3, 2, 2, 1) Ns. to E pos. on next 2 (2, 2, 8, 2) Rs. Push Ns. on Lt. to C pos. K. 1. H.C.L. I. K. 1. C/O.

### HOOD

**Step 1.** In 4 ply. C.O.B.H. 121 (127, 133, 139, 145) sts. T6. K. 2 Rs.

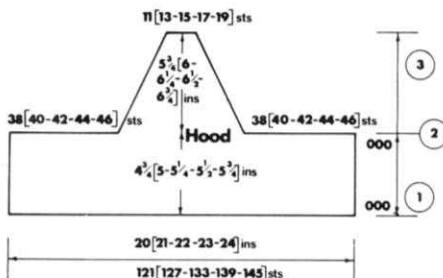

C.O.R. 000. Start weave-patt. from graph. S.D. on 1. T8. K. 42 (44, 46, 48, 50) Rs. straight.

**Step 2.** C/O. 38 (40, 42, 44, 46) sts. at beg. next 2 Rs. C.O.R. 000.

**Step 3.** Dec. 1 st. on each edge ev. 3 Rs. 17 times. K. to 52 (54, 56, 58, 60) Rs. C/O.

### TO MAKE UP

Press all pieces. Join shoulders. Sew tops of sleeves into armholes. Press seams. Join side and sleeve seams. On hood, join C/O. edges (at step 2) to dec. edges (at step 3). Press seams. Starting at side of Front Neck, pin hood in pos. around neck. Sew in place. Press all seams.

### FRONT-OPENING LOOPS

In 4 ply. C.O.B.H. 19 (19, 23, 23, 27) sts. T6. K. 2 Rs. \* Set M/c. for weave. Select ev. alt. N. in weave pos. (edge Ns. must be selected). Holding a 1 in. deep ruler horizontally under Ns., with weave Y. place over 1 st. N. on Rt. edge, wind around ruler and over next N. in C pos. Cont. in this way to Lt. edge. K. 2 Rs. Repeat loops working from Lt. to Rt. edge. K. 2 Rs. \* Cont. in this way until edging is long enough to fit across back, up both fronts and around hood, stretching slightly. C/O. Starting at centre back pin edging to edge of coat and slip-st. in place. Press seams. Fold edging over onto inside of coat and join to seam.

### SLEEVE LOOPS (Knit 2)

K. edging as before until long enough to fit around sleeve. Attach to sleeves as before. Sew three buttons onto Lt. inside front edge. Using 4 ply make three loops on Rt. inside front edge to correspond with buttons.

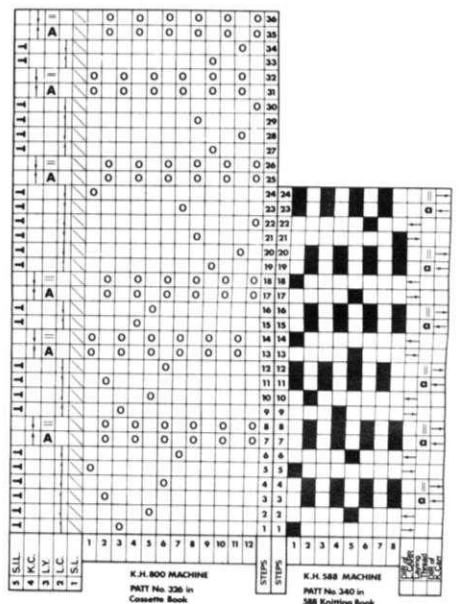



# v-neck classic sweater

## Materials

9 (10, 10, 11) ozs. of Lister Lavenda Crisp Crepe 4 ply in main colour and 1 oz. each in 2 contrasting colours.

## Measurements

To fit bust size 32 (34, 36, 38) ins.  
Actual measurements 33 (35, 37, 39) ins.  
Length from shoulder 19½ (20, 20½, 21) ins.  
Sleeve seam 16½ ins.

## Tension

T8. 7 sts. and 10 rows to 1 in.

## Abbreviations

K., knit; sts., stitch(es); inc., increase; dec., decrease; foll., following; alt., alternate; beg., beginning; rem., remain; H.P., holding position; W.P., working position; T., tension; 000., set row counter to 000; M.B., main bed.

## Note

This garment was made on a machine with ribbing attachment.

## BACK

With main colour, cast on 101 (109,

115, 123) sts. as 1 x 1 rib. T6/6. K. 20 rows. Transfer ribber sts. to M.B. 000. T8. K. 2 rows. Foll. Chart I K. 10 rows. Break off contrast yarns and with main colour only work as follows: Inc. 1 st. at each end of the next row and every foll. 10th row until there are 115 (123, 129, 137) sts. K. to 110 rows.

## Shape Armholes

Cast off 5 sts. at beg. of next 2 rows. Dec. 1 st. at each end of every row until 99 (103, 109, 117) sts. rem., then every alt. row until 87 (91, 95, 99) sts. rem. K. to 178 (182, 186, 190) rows.

## Shape Shoulders

Cast off 10 sts. at beg. of next 4 rows, and 7 (8, 9, 10) sts. on foll. 2 rows. Leave the remaining 33 (35, 37, 39) sts. on waste yarn for neck band.

## CHART I

x	x	x		x	x	x	x	x		x	x	10
x	x	x		x	x	x	x	x		x	x	9
O	O			O	O	O				O		8
O	O			O	O	O				O		7
x			x			x			x			6
x			x			x			x			5
		O	O	O				O	O	O		4
		O	O	O				O	O	O		3
	x	x	x	x	x		x	x	x	x	x	2
	x	x	x	x	x		x	x	x	x	x	1
1	2	3	4	5	6	7	8	9	10	11	12	

K.H.800 MACHINE

STEPS

- Main colour
- x 1st contrast
- O 2nd contrast

## FRONT

Work as given for back to armholes. 115 (123, 129, 137) sts.

## Shape Armhole and divide for Neck

Dec. 1 st. at centre, then place 57 (61, 64, 68) needles at left into H.P. Work on remaining sts. for right front shoulder.

## Right front Shoulder

Next row: Cast off 5 sts. K. to end. Dec. 1 st. at armhole edge on each of the next 3 (5, 5, 5) rows and the foll.; 6 (6, 7, 8) alt. rows **at the same time** dec. 1 st. at neck edge on the next row and every foll. 4th row until 27 (28, 29, 30) sts. rem. Work until front matches back to shoulder ending at armhole edge.

## Shape Shoulder

Cast off 10 sts. at beg. of next row and foll. alt. row. Work 1 row, then cast off.

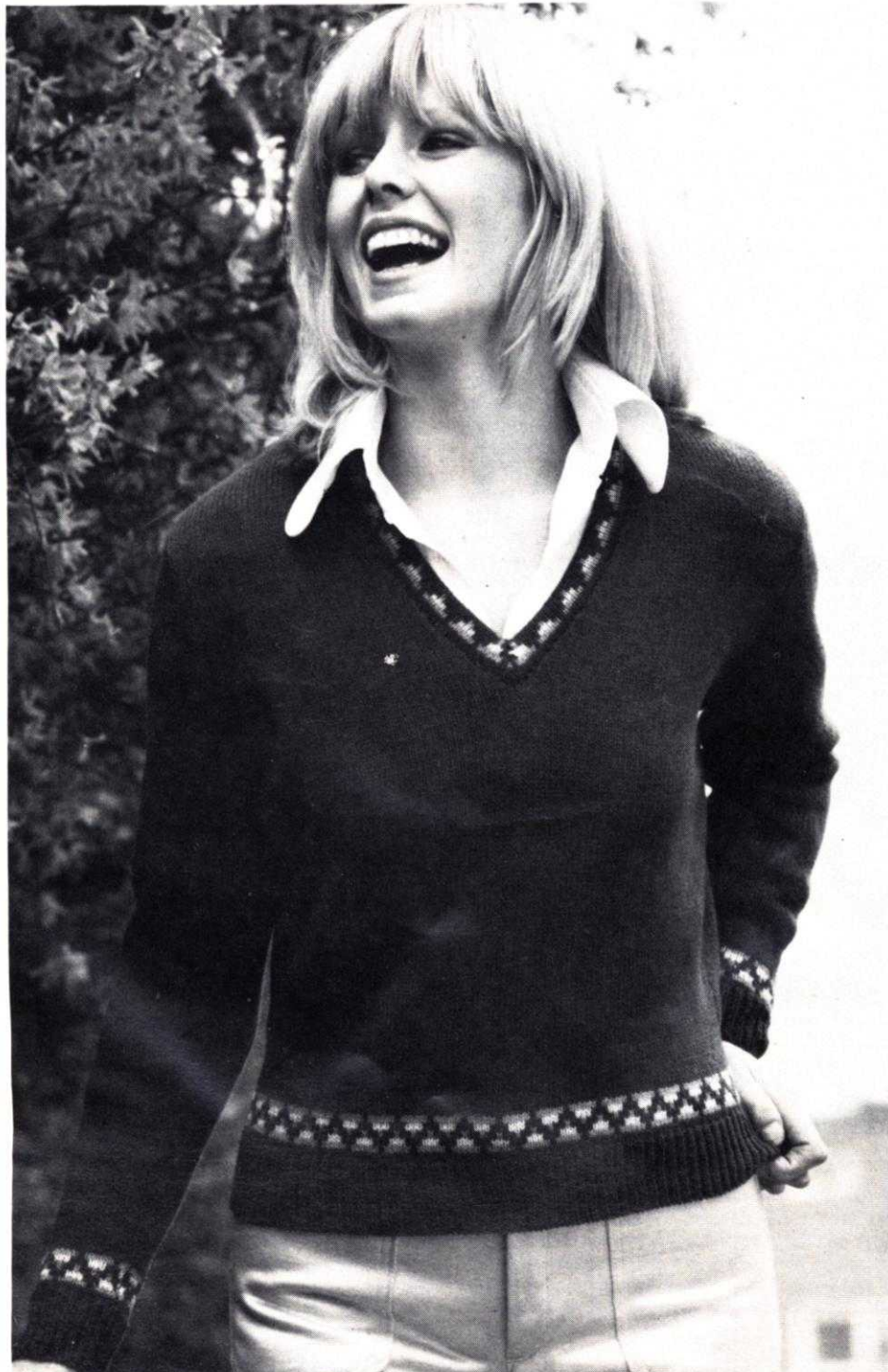







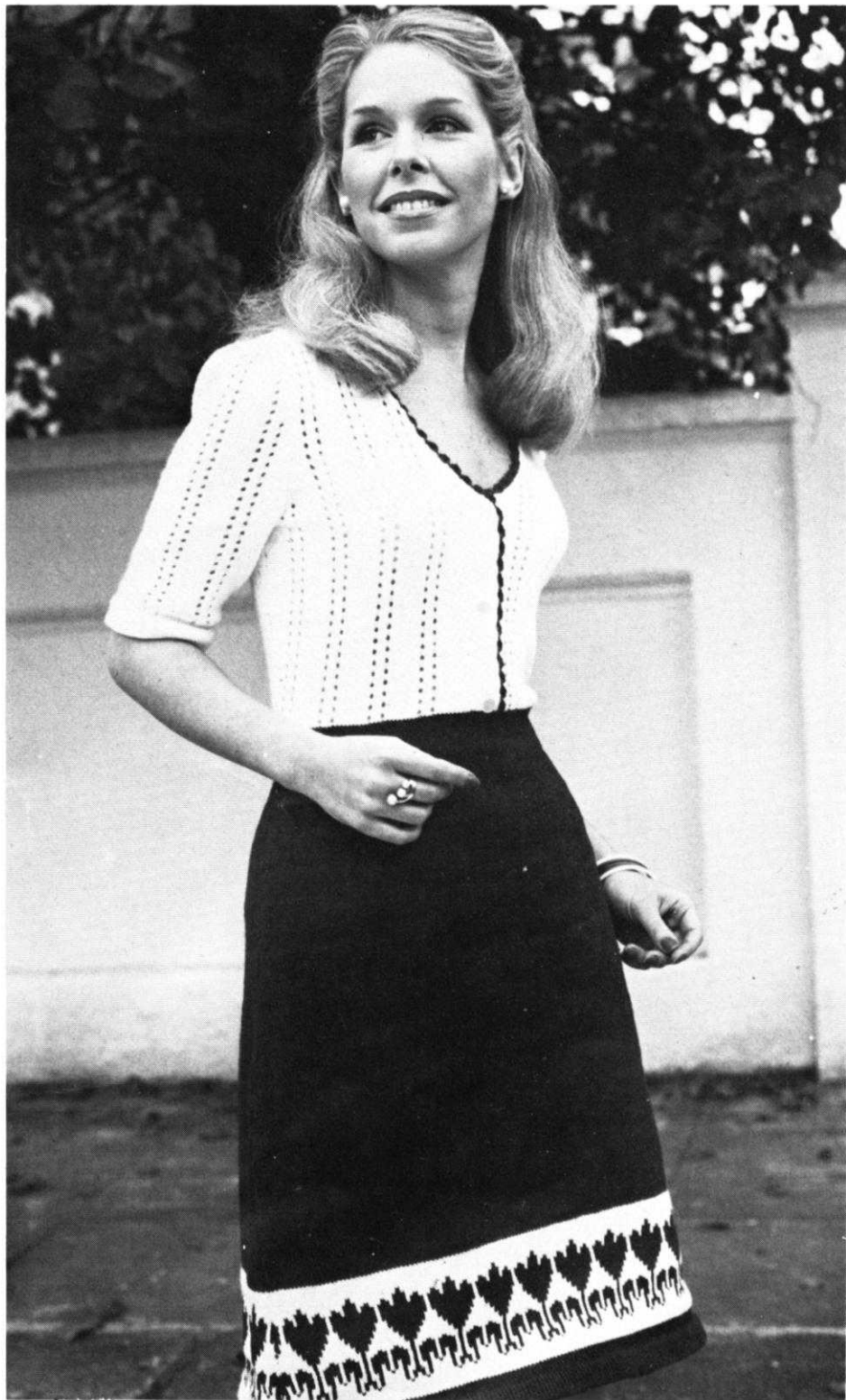
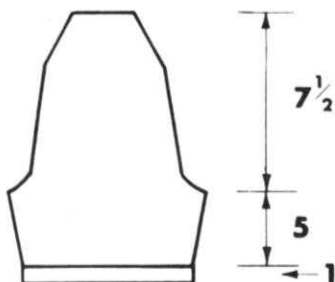
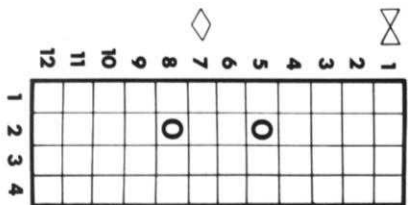
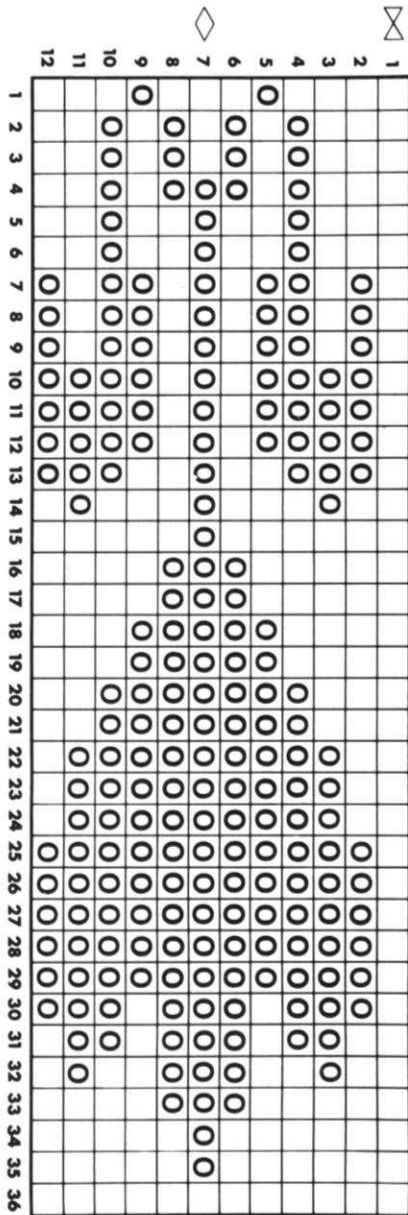

**SLEEVES**

Cast on 78 sts. T5, K. 12 rows. T8, K. 1 row. T5, K. 12 rows. M.D.E. K. 1 row 1st at each end of every 9th row to 86 sts. Cont. straight to 48 rows. Cast off 7 sts. at beginning of next 2 rows. K. 1 row. Dec. 1 st. at each end of next and every foll. alt. row until 50 sts. remain. K. to row 68. Cast off 3 sts. at beginning of next 10 rows. Cast off remaining 20 sts.

**TO MAKE UP**

Press. Sew up side and shoulder seams and insert sleeves gathering slightly at top. In MN., right side facing, No. 7 crochet hook, work icots up R. side of front, along back of neck and down L. side of front as follows: 1 d.c. 3 tr. 1 d.c. all into same st. miss 3 sts. and repeat to end. Join lower edge of buttonband to top of skirt. Press seams. Sew on buttons.

# short sleeved jacket and cardigan

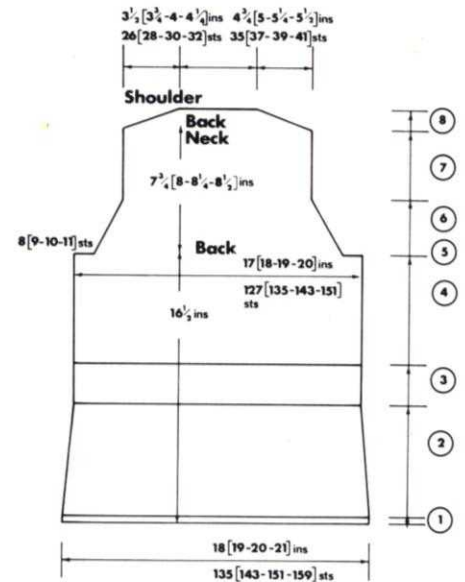

## JACKET BACK

**Step 1.** C.O.B.H. 135 (143, 151, 159) sts. \* T5. K. 8. T7. K. 1. T5. K. 8. \* M.D.E. T7. K. 1 C.O.R. 000.

**Step 2.** Dec. 1 st. on each edge ev. 19 Rs., 4 times. K. to 78 Rs. C.O.R. 000.

**Step 3.** Trans. Ns. as for 1 x 1 rib. T3/3. K. 30 Rs. straight. Trans. Ns. to M.B. C.O.R. 000.

**Step 4.** K. 76 Rs. Straight.

**Step 5.** C/O. 8 (9, 10, 11) sts. at beg. next 2 Rs. C.O.R. 000.

**Step 6.** Dec. 1 st. on each edge ev. 3 Rs. 12 times. To 36 Rs. C.O.R. 000.

**Step 7.** K. 50 (52, 54, 56) Rs. straight.

**Step 8.** \* H.C.L.'s II. \* Push 6 (6, 6, 7) Ns. to E pos. at opp. end to carr. on next 2 (6, 6, 4) Rs. Then 5 (5, 6, 6) Ns. to E pos. on next 8 (4, 4, 6) Rs. Push Ns. on Lt. back to C pos. K. 1. H.C.L. I. K. 1. Thread-up back neck sts. and C/O. shoulders.

## LEFT FRONT

**Step 1.** C.O.B.H. 63 (67, 71, 75) sts. Make hem as for back \* to \*. M.D.E. T7. K. 1. C.O.R. 000.

**Step 2.** Dec. 1 st. on Rt. edge ev. 19 Rs. 4 times. K. to 78 Rs. C.O.R. 000.

**Step 3.** Trans. Ns. as for 1 x 1 rib. T3/3. K. 30 Rs. straight. \* Break off Y. Place carr. on Lt. side of M/c. H.C.L.'s II. On Rt. edge (on both beds), push up 29 (33, 37, 41) Ns. in all to E pos. K. 2 Rs. C.O.L. On Rt. edge push 2 Ns. to E pos. ev Alt. R. 15 times. Break-off Y. Place carr. on Rt. side of M/c. On Rt. edge trans. 29 (33, 37, 41) Ns. from rib bed and M.B. back to B pos. on M.B. Always taking Y. round inside N. in Epos. T7. K. 2 Rs. in st.st. Trans. 2 Ns. to B pos. on M.B. ev. alt. R. 15 times, until all Ns. are on M.B. C.O.R. 030. K. to 034 Rs. Start lace-motif from graph,

## Materials

**Jacket** 16 (17, 18, 19) balls of Lister Lavenda or Lee Target Motoravia 4 ply wool. 5 buttons.

**Jumper** 12 (13, 14, 15) balls of Lister Lavenda or Lee Target Motoravia 4 ply wool.

## Measurements

To fit 32 (34, 36, 38) ins. bust.

**Jacket** Finished measurements 34 (36, 38, 40) ins. bust.

Length from Back Neck 25 <sup>3</sup>/<sub>4</sub> (26, 26 <sup>1</sup>/<sub>4</sub>, 26 <sup>1</sup>/<sub>2</sub>) ins.

**Jumper** Finished measurement 33 (35, 37, 39) ins. bust.

Length from Back Neck 23 <sup>3</sup>/<sub>4</sub> (24, 24 <sup>1</sup>/<sub>2</sub>, 24 <sup>1</sup>/<sub>2</sub>) ins.

Inside Sleeve Length 17 (17 <sup>1</sup>/<sub>2</sub>, 17 <sup>1</sup>/<sub>2</sub>, 18) ins.

## Tensions

7 <sup>1</sup>/<sub>2</sub> sts. and 11 rows to 1 in. on T7 over st.st.

7 sts. and 14 rows to 1 in. on T7 over pattern.

**Note** Purl side of fabric is right side. \* H.C.L.'s II \*—Always take Y. round inside N. in E pos.

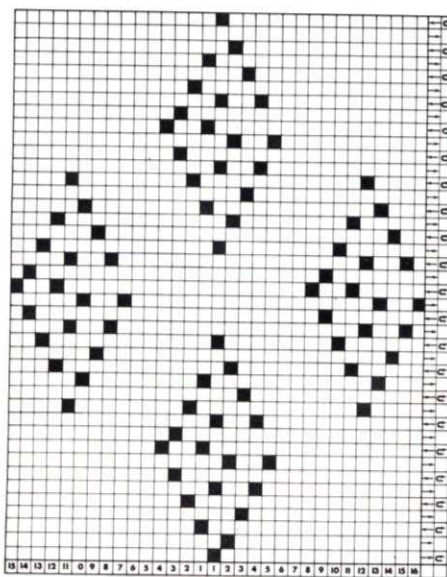



with 1 st. lace-hole on the 32 (34, 36, 38) N. in from Rt. edge. After 76 Rs. start armhole.

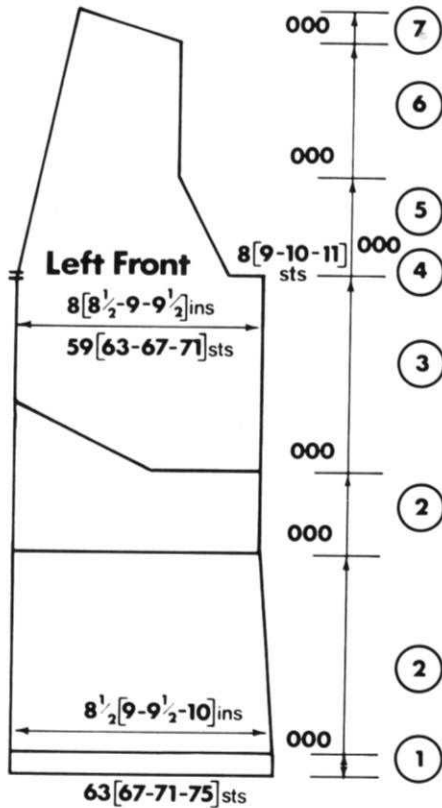

**Step 4.** C/O. 8 (9, 10, 11) sts. on Rt. edge. K. 2 Rs. C.O.R. 000.

**Step 5.** Mark Lt. edge st. with contrast coloured Wl. Dec. this st. Then on Lt. edge dec. 1 st. ev. 4 Rs. 12 (13, 14, 15) times. **At the same time** on Rt. edge dec. 1 st. ev. 3 Rs. 12 times. To 36 Rs. C.O.R. 000.

**Step 6.** K. 50 (52, 54, 56) Rs. straight.

**Step 7.** K. 1. C.O.L. \* H.C.L.'s. II \* Push 6 (6, 6, 7) Ns. on Rt. edge to E pos. ev. alt. R. 1 (3, 3, 2) times. Then 5 (5, 6, 6) Ns. to E pos. 4 (2, 2, 3) times. Return Ns. to C pos. K. 1. C/O.

#### RIGHT FRONT

As for Lt. from \* to \* making shaping on Lt. edge. On Lt. edge (on both beds), push 29 (33, 37, 41) Ns. in all to E pos. K. 2 Rs. C.O.R. On Lt. edge push 2 Ns. to E pos. ev. alt. R. 15 times. Break off Y. Place carr. on Lt. side of M/c. On Lt. edge trans. 29 (33, 37, 41) Ns. from rib bed and M.B. back to B pos. on M.B. Always taking Y. round inside N. in E pos. T7. K. 2 Rs. in st.st. Trans. 2 Ns. to B pos. on M.B. ev. alt. R. 15 times until all Ns. are on M.B. Break off Y. Place carr. on Rt. 030 Rs. K. to 034 Rs. Start lace-patt. from graph starting 1 st. hole the 32 (34, 36, 38) th N. in from Lt edge. After 76 Rs. start armhole.



**Step 4.** K. 1 C/O. 8 (9, 10, 11) sts. on Lt. edge, K. 1 C.O.R. 000.

**Step 5.** As for Lt. front reversing all shapings.

**Step 6.** As for Lt.

**Step 7.** \* H.C.L.'s II \* Push 6 (6, 6, 7) Ns. to E pos. on Lt. edge ev. alt. R. 1 (3, 3, 2) times. Then 5 (5, 6, 6) Ns. to E pos. 4 (2, 2, 3) times. Return Ns. to C pos. K. 1. C/O.

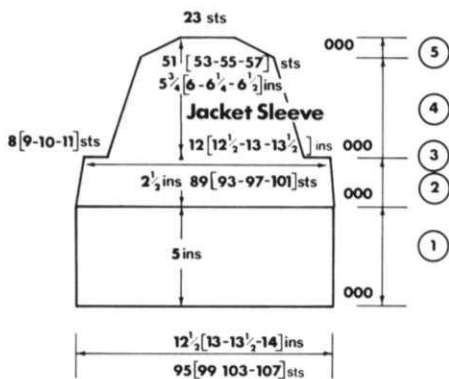

### JACKET SLEEVES

**Step 1.** Cast on 95 (99, 103, 107) sts. as 1 x 1 rib. T1/1. K. 4 Rs. Tub. T3/3. K. 60 Rs. rib. Trans. Ns. to M.B. C.O.R. 000.

**Step 2.** Dec. 1 st. on each edge ev. 8 Rs. 3 times. K. to 28 Rs.

**Step 3.** C/O. 8 (9, 10, 11) sts. at beg. next 2 Rs. C.O.R. 000.

**Step 4.** Dec. 1 st. on each edge ev. 5 Rs. 11 times. K. to 56 Rs. C.O.R. 000.

**Step 5.** \* H.C.L.'s II \* Push 3 Ns. to E pos. at opp. end to carr. on next 4 (4, 8, 6) Rs. Then 4 (3, 2, 2) Ns. to E pos. on next 4 (6, 4, 8) Rs. Push Ns. on Lt. to C pos. K. 1. H.C.L. I. K. 1. C/O. Repeat sleeve.

### TO MAKE UP

Press all pieces.

### POCKETS

C.O.B.H. 39 sts. T7. K. 6 Rs. Start lace-motif from graph with 1 st. lace-hole on centre st. K. 42 Rs. of patt. K. 4 Rs. Thread-up sts. and take off M/c. Repeat pocket.

### BANDS

C.O.B.H. 39 sts. K. as \* to \* step 1. M.D.E. With purl side of pocket facing M/c., place sts. onto Ns. and C/O. Repeat Band and C/O. Press. Place onto fronts with bottom of pockets level with bottom of hems, and 2 ins. away from front edges. Pin and then slip-st. in place. Join shoulders. Sew tops of sleeves into armholes. Press seams. Join side seams. On wrong side join cuff seams for 3 ins. On outside join rem. of sleeves. Press seam. Fold back cuffs and slip-st. to secure in place.

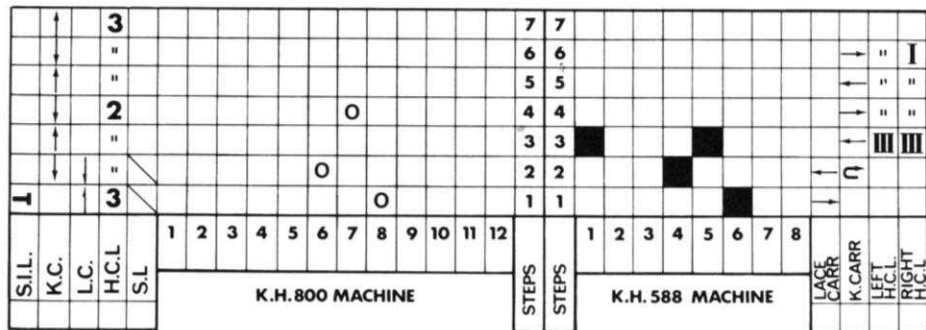

### BUTTON BAND

Cast on 24 Ns. as 'all-needle' rib. (With last st. on Lt. on rib bed.) T0/O. K. 2 Rs. Tub. T2/2. K. 191 Rs. rib. Then dec. 1 st. on Lt edge ev. R. 20 times. C/O. Rem. sts. Pin band onto Lt. front with top of band level with marked st. Slip-st. in place.

### BUTTONHOLE BAND

Cast on 24 Ns. (With last st. on Rt. edge on rib bed.) T0/O. K. 2 Rs. Tub. T2/2. K. 4 Rs. rib. \* Push 12 Ns. on Lt. to E pos. H.C.L.'s II. K. 11 Rs. C.O.L. Push all Ns. to E pos. Break off Y. Move carr. to Rt. side of M/c. Return 12 Ns. on Lt. to C pos. K. 11 Rs. C.O.L. Return Ns. on Rt. to C pos. K. 33 Rs. straight \*. Repeat from \* to \* making 5 buttonholes in all. 191 Rs. Then dec. 1 st. on Rt. edge ev. R. 20 times. C/O. Rem. sts. Pin band onto Rt. front and cont. as before.

### COLLAR

Cast on 181 (187, 193, 199) sts. as 1 x 1 rib. T1/1. K. 4 Rs. Tub. T3/3. \* H.C.L.'s II \* Push 52 Ns. to E pos. at opp. end to carr. on next 2 Rs. Return 2 Ns. to C pos. at opp. end to carr. on next 52 Rs. Trans. Ns. to M.B. With purl side of garment facing M/c., place side neck (including shaped edge of front band), to 74 (76, 78, 80) Ns. Place back neck to next 33 (35, 37, 39) Ns. and rest of neck and band to rem. Ns. C/O. to end. Press collar and front band seams. Turn collar to outside and carefully press and ease to fit neck. Slip-st. to secure in place. Sew on buttons to correspond with holes.

### JUMPER BACK

**Step 1.** Cast on 115 (123, 131, 139) sts. as 1 x 1 rib. \* T1/1. K. 4 Rs. Tub. T3/3. K. 30 Rs. rib. Trans. Ns. to M.B. C.O.R. 000. \*

**Step 2.** Start patt. from graph. T7. K. 42 Rs. of patt. **At the same time** inc. 1 st. on each edge ev. 28 Rs. 4 times. K. to 124 Rs.

**Step 3.** C/O. 6 (7, 8, 9) sts. at beg. next 2 Rs. C.O.R. 000.

**Step 4.** Dec. 1 st. on each edge ev. 3 Rs. 12 times. To 36 Rs. C.O.R. 000.

**Step 5.** K. 44 (46, 48, 50) Rs. straight. C.O.R. 000.

**Step 6.** \* H.C.L.'s II \* Push 6 Ns. to E pos. at opp. end to carr. on next 2 (6, 6, 6) Rs. Then 5 (5, 6, 7) Ns. to E pos. on next 8 (4, 4, 4) Rs. Push Ns. on Lt. to C pos. K. 1. H.C.L. I. K. 1. C/O. shoulders. Thread-up Back Neck sts.

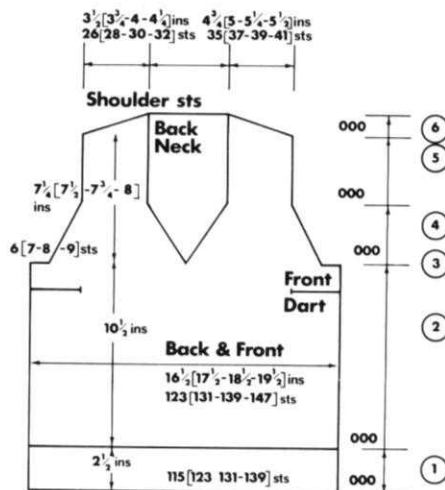

### FRONT

**Step 1.** As for Back.

**Step 2.** T7. K. 42 Rs. of patt. \* Select step 1 of patt. from graph. Starting from the centre, count 5 repeats of lace holes across to Lt. and 5 to right. Push rem. Ns. back to B pos. K. step 2, (9 holes in all). \* Select step 3. Starting from centre count 10 repeats of pull-up patt. across to Lt. and 10 to Rt., (19 in all). Push rem. Ns. back to B pos. K. steps 3 to 6. Repeat from \* to \*. Select step 3. Count 17 repeats of pull-up patt. and push rem. Ns. back to B pos. K. steps 3 to 6. Repeat from \* to \* only selecting 7 lace holes. Select 15 repeats of pull-up patt. K. steps 3 to 6. Repeat from \* to \* selecting 7 lace holes. Select 13 repeats of pull-up patt. Cont. in this way until only one repeat of pull-up patt. rem. in centre. To 102 Rs. **At the same time** shape as for back step 2. K. to 112 Rs.

### DARTS

\* H.C.L.'s II \* Push 20 (22, 24, 26) Ns. to E pos. at opp. end to carr. on next 2 Rs. Then push 2 Ns. to E pos.



on next 10 (12, 14, 16) Rs. Return 2 Ns. to C pos. on next 10 (12, 14, 16) Rs. Push rem. Ns. to C pos. at opp. end to carr. on next 2 Rs. C.O.R. 114. Cont. to 124 Rs.

**Step 3.** As for back.

**Step 4.** Thread-up sts. to Lt. of centre and take off M/c. On Rt. edge make decs. as for back. On Lt. edge dec. 1 st. at 000. Then ev. alt. R. 17 (18, 19, 20) times. After 36 Rs. start step 5. C.O.R. 000.

**Step 5.** K. to 44 (46, 48, 50) Rs. C.O.R. 000.

**Step 6.** \* H.C.L.'s II \* K. 1. Push 6 Ns. to E pos. on Rt. edge ev. alt. R. 1 (3, 3, 3) times. Then push 5 (5, 6, 7) Ns. to E pos. 4 (2, 2, 2) times. H.C.L. I. K. 1. C/O. shoulder.

#### LEFT NECK

Replace thread-up sts. on to M/c. C.O.R. 000.

**Step 4.** On Lt. edge make decs. as for back. On Rt. edge dec. 1 st. ev. alt. R. 17 (18, 19, 20) times. After 36 Rs. start step 5.

**Step 5.** As before.

**Step 6.** \* H.C.L.'s II \* Push 6 Ns. to E pos. on Lt. edge ev. alt. R. 1 (3, 3, 3) times. Then 5 (5, 6, 7) Ns. 4 (2, 2, 2) times. H.C.L. I. K. 1. C/O.

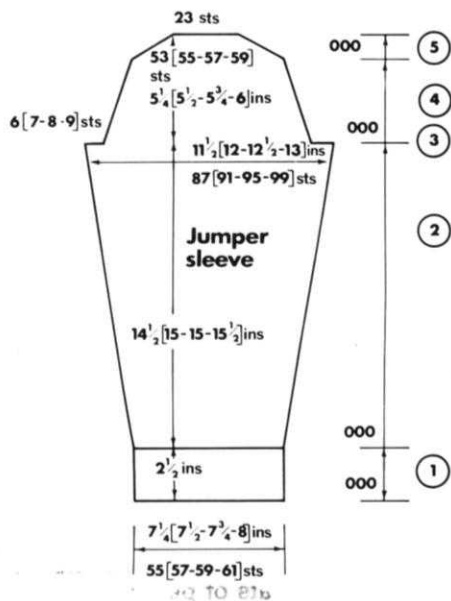

#### JUMPER SLEEVE

**Step 1.** Cast on 55 (57, 59, 61) sts. as 1 x 1 rib. K. hem as \* to \* back.

**Step 2.** Inc. 1 st. on each edge ev. 9 Rs. 8 (14, 18, 19) times. Then ev. 10 Rs. 8 (3, 0, 0) times. K. to 160 (166, 166, 172) Rs.

**Step 3.** C/O. 6 (7, 8, 9) sts. at beg. next 2 Rs. C.O.R. 000.

**Step 4.** Dec. 1 st. on each edge ev. 5 Rs. 11 times. K. to 56 Rs. C.O.R. 000.

**Step 5.** \* H.C.L.'s II \* Push 8 (6, 5, 4) Ns. to E pos. at opp. end to carr. on



next 2 (2, 2, 6) Rs. Then 7 (5, 4, 3) Ns. to E pos. on next 2 (4, 6, 4) Rs. Push Ns. on Lt. to C pos. K. 1. H.C.L. I. K. 1. C/O. Repeat.

#### TO MAKE UP

Press all pieces. Join shoulders. Sew tops of sleeves into armholes. Press seams. Join side and sleeve seams.

#### NECK BAND

Cast on 133 (139, 145, 151) sts. as

1 x 1 rib. T1/1. K. 4 Rs. Tub. T3/3. Inc. 1 st. on each edge ev. alt. R. 6 times. (12 Rs.) To 145 (151, 157, 163) sts. Trans. Ns. to M.B. With purl side of work facing M/c. Place side neck to 56 (58, 60, 62) Ns. Place B.N. to 33 (35, 37, 39) Ns. and rest of neck to rem. Ns. C/O. to end. Join band at front. Press all seams and band.

# childrens' windcheaters

## Materials

**Style A** 16 (17, 18, 19) balls of M. Wl. Lister Euro-spun Double Knitting (Terylene/Wool). 8 (8, 9, 9) balls of contrast Wl. Lister Euro-spun Double Knitting (Terylene/Wool).

**Style B** 9 (9, 10, 10) balls of M. Wl. Lister Euro-spun Double Knitting (Terylene/Wool). 6 (6, 7, 7) balls of colour B Lister Euro-spun Double Knitting (Terylene/Wool). 11 (12, 13, 14) balls of colour C Lister Euro-spun Double Knitting (Terylene/Wool). 18 (18, 20, 20) ins. open-ended zip.

## Measurements

To fit 28 (30, 32, 34) ins. chest.  
Finished measurement 30 (32, 34, 36) ins. chest.

Sleeve seam  $14\frac{1}{2}$  ( $13\frac{1}{2}$ ,  $16\frac{1}{2}$ ,  $17\frac{1}{2}$ ) ins.

Length from back neck 19 (20, 21, 22) ins.

## Tension

7 sts. and 9 Rs. to 1 in. on T8 (810 M/cs.  $T8\frac{2}{3}$ ) with yarn feeder on loosest T.

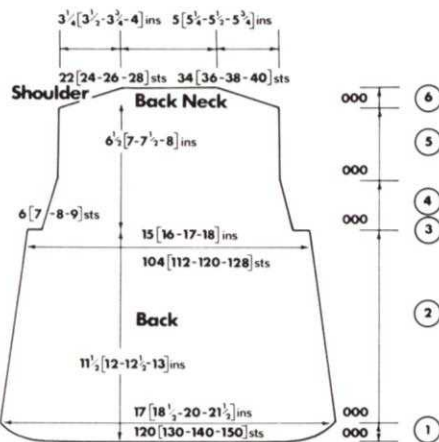

## BACK

**Step 1.** With W. Wl. cast on 120 (130, 140, 150) sts. K. a few Rs. Change to M. Wl. \* H.C.L.'s II \* Push 25 Ns. to E pos. on Lt. edge. K. 1. Set M/c. to jacq. Push 25 Ns. to E pos. on Rt. edge. K. 1. Start jacq. from graph, step 1. Return 5 Ns. to C pos. at opp. end to carr. on next 10 Rs. C.O.R. 000.

**Step 2.** Dec. 1 st. on each edge ev. 11 (11, 9, 9) Rs. 8 (9, 10, 11) times. K. to 96 (100, 104, 108) Rs.

**Step 3.** C/O. 6 (7, 8, 9) sts. at beg. next 2 Rs. C.O.R. 000.

**Step 4.** Dec. 1 st. on each edge ev. 4 Rs. 7 times. To 28 Rs. C.O.R. 000.

**Step 5.** K. 32 (36, 40, 44) Rs. straight. C.O.R. 000.

**Step 6.** \* H.C.L.'s II \* Push 5 (5, 6, 6) Ns. to E pos. at opp. end to carr. on next 4 (8, 2, 6) Rs. Then 4 (4, 5, 5) Ns. to E pos. on next 6 (2, 8, 4) Rs. Push Ns. on Lt. to C pos. K. 1. H.C.L. I. K. 1. C/O. to end.

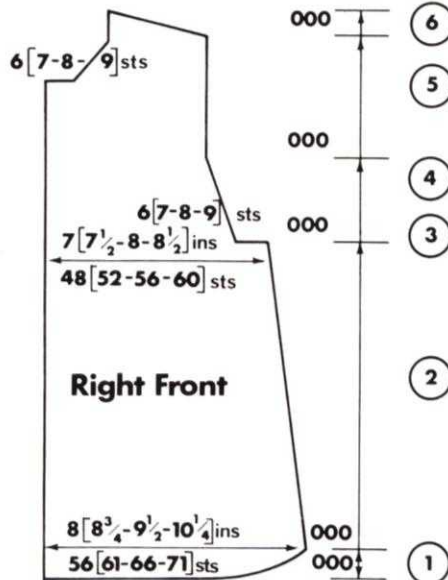
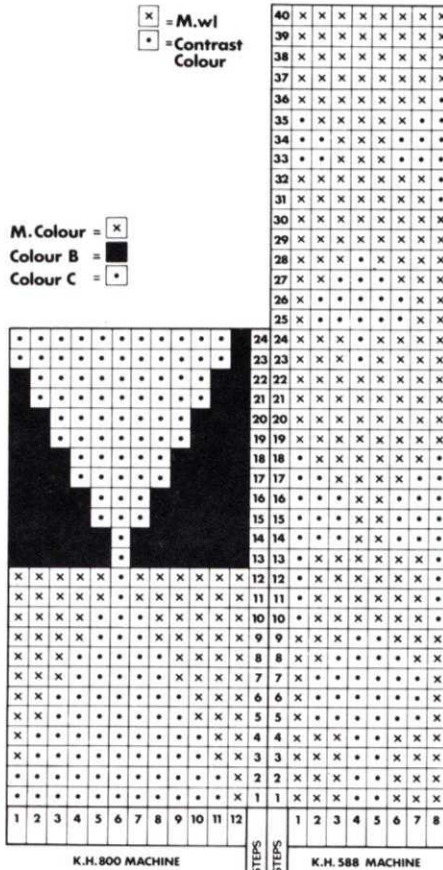

## RIGHT FRONT

(For patt. A. cast on 4 sts. to Lt. of centre, rem. to Rt. For patt. B. cast on 7 sts. to Lt. of centre, rem. to Rt.)

**Step 1.** With W. Wl. cast on 56 (61, 66, 71) sts. K. a few Rs. Change to M. Wl. \* H.C.L.'s II \* K. 1 C.O.L. Push 25 Ns. to E pos. on Rt. edge. Set M/c. to jacq. K. 1. Start jacq. from graph, step 1. K. 1. Return 5 Ns. to C pos. on Rt. edge ev. alt. R. 10 times. C.O.R. 000.

**Step 2.** As for back, shaping on Rt. edge only.

**Step 3.** C/O. 6 (7, 8, 9) sts. K. 2 Rs. C.O.R. 000.

**Step 4.** As for back shaping on Rt. edge only.

**Step 5.** K. 16 (18, 20, 22) Rs. to Front Neck. K. 1. C/O. 6 sts. on Lt. edge. K. 1. Dec. 1 st. on neck edge ev. alt. R. 7 (8, 9, 10) times. To 32 (36, 40, 44) Rs. C.O.R. 000.

**Step 6.** K. 1. \* H.C.L.'s II \* Push 5 (5, 6, 6) Ns. to E pos. on Rt. edge ev. alt. R. 2 (4, 1, 3) times. Then 4 (4, 5, 5) Ns. to E pos. ev. alt. R. 3 (1, 4, 2) times. Push Ns. to C pos. K. 1. C/O.

## LEFT FRONT

(For patt. A. cast on 4 sts. to Rt. of centre, rem. to Lt. For patt. B. cast on 6 sts. to Rt. of centre, rem. to Lt.) K. as for Rt. front reversing all shapings.

## SLEEVES

**Step 1.** In M. Wl. C.O.B.H. 60 (60, 64, 64) sts. T6. K. 8. T9. K. 1. T6. K. 8. M.D.E. T8. (810 M/c.  $T8\frac{2}{3}$ ). Set M/c. to jacq. K. 1. C.O.R. 000.

**Step 2.** (For patt. A. start patt. step 22 (16, 12, 6) from graph. For patt. B. start step 6 (1, 20, 14) from punch-card.) Inc. 1 st. on each edge

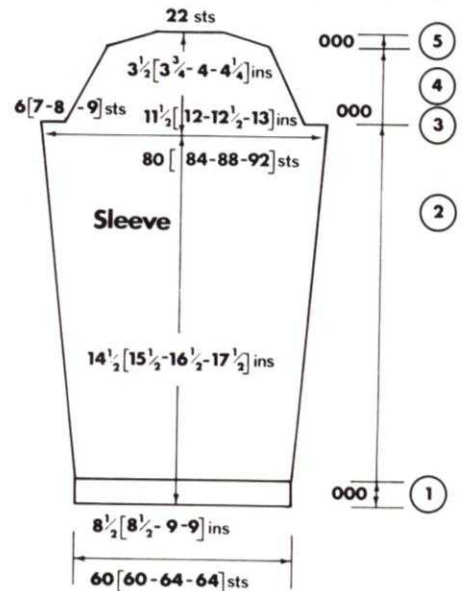

ev. 12 (11, 11, 10) Rs. 10 (12, 12, 14) times. K. to 124 (134, 142, 152) Rs.

**Step 3.** C/O. 6 (7, 8, 9) sts. at beg. next 2 Rs. C.O.R. 000.

**Step 4.** Dec. 1 st. on each edge ev. Dec. 1 st. on each edge ev. 3 Rs. 9 (10, 11, 12) times. K. to 30 (32, 34, 36) Rs. C.O.R. 000.

**Step 5.** \* H.C.L.'s II \* Push 7 sts. to E pos. at opp. end to carr. on next 4 Rs. Return Ns. on Lt. to C pos. K. 1. H.C.L. I. K. 1. C/O. Repeat.

## HOOD

**Step 1.** In M. Wl. C.O.B.H. 176 (184, 192, 200) sts. T6. K. 6. T9. K. 1. T6.



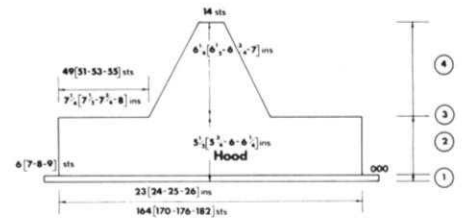

K. 6. M.D.E. T8. (810 M/cs. T8 $\frac{2}{3}$ ). Set M/c. for jacq. K. 1. C.O.R. 000. With W. WI. thread-up 6 (7, 8, 9) sts. at each end and take off M/c.

**Step 2.** (For patt. A. start patt. at step 18 and use patt. in reverse. For patt. B. start at step 1 and cont. as normal.) K. 46 (48, 50, 52) Rs. straight.

**Step 3.** C/O. 49 (51, 53, 55) sts. at beg. next 2 Rs. C.O.R. 000.

**Step 4.** Dec. 1 st. on each edge ev. alt. R. 26 (27, 28, 29) times. K. to 56 (58, 60, 62) Rs. C/O.

#### TO MAKE UP

Press all pieces. Join fronts to back at shoulders. Sew tops of sleeves into armholes. On hood join C/O. edges to dec. edges. Press all seams.

#### BANDS

##### BACK

In M. WI. C.O.B.H. 104 (112, 120, 128) sts. \* T6. K. 6. T9. K. 1. T6. K. 6. M.D.E. \* With Rt. side of work facing M/c., place lower edge evenly onto Ns. (doubling-up on some sts.) Remove W. WI. C/O.

##### FRONTS

In M. WI. C.O.B.H. 52 (56, 60, 64) sts. K. as for back. On Rt. edge thread-up 4 sts. and take off M/c. Place Rt. front edge evenly onto Ns. (doubling-up on some sts.) C/O. Repeat band and thread-up 4 sts. on Lt. edge. Place Lt. front to sts. and C/O.

##### FRONT BANDS

In M. WI. C.O.B.H. 114 (118, 122, 126) sts. K. as for back band from \* to \*. Starting 1 st. in from each edge, place front evenly onto Ns. C/O. Repeat band. Join side and sleeve seams. Sew hood around neck edge with each end of hem edge joining top of front band edge. Join lower edge of front bands to thread-up sts. on front hem bands. Pin zip in pos. and st. in place. Press all seams and bands.

##### ROULLEAUS

In contrast WI. Cast onto 3 sts. Press one part-button in. T2. (Yarn T. on tight.) K. until band measures approx. 54 ins. C/O. K. another approx. 48 ins. long. Thread long rouleau through waist band and shorter rouleau through hood hem. Tie ends of rouleaus in tight knot to stop it unthreading.



# IT'S HERE!

The world's easiest-to-operate

FULLY AUTOMATIC

Knitting Machine

## Jones

# KnitOMatic

A marvel of technology  
miraculously simple to use

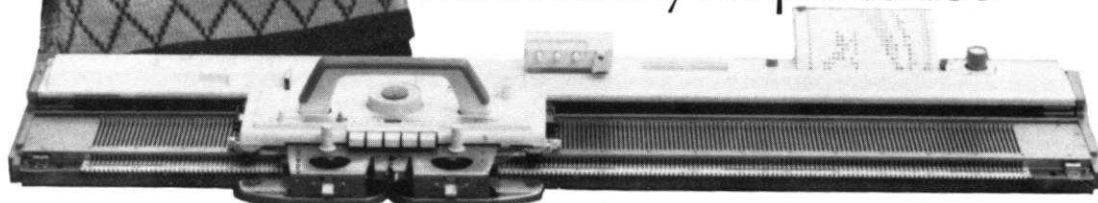

All you do:- Insert your pattern-programme card

this feeds the machine its directions

Slide the carriage to and fro

watch your knitting – including the most intricate patterns – grow before your very eyes

Just think of the world of possibilities the Knit-o-matic opens up! You'll save time – and pounds and pounds on all your family garments.

The Jones Knit-o-matic is the finest machine of its kind on the market. Compare the price – and compare the performance. You'll see why it's worth paying just that little bit more.

**See the Jones  
KnitOMatic and  
OPEN UP A WHOLE  
NEW WORLD at:-**

Ask for a demonstration.

A **FREE** 5-minute lesson  
– all you need to  
know – will be given by  
our dealer expert.

*Drop us a line for details of your nearest  
stockist who can offer demonstration and  
part-exchange facilities.*

V. Hughes, Esq  
Knitting Machine Manager  
Jones Sewing Machine Co Ltd  
Britannia House  
964 High Road, Finchley  
London N12 8LE



Many customers already know that the knitting machines made for Jones are manufactured by their associated company called Brother Industries in Japan. They are the largest manufacturers of domestic knitting machines in the world making and selling between 400,000 and 500,000 units per year. The majority of this phenomenal total is still sold in Japan and only a very small percentage is sold on the world market. We in Jones are one of their major customers and sell four models. This is unlike the Japanese market where they always concentrate on the very latest machine and discontinue earlier models the minute a new model arrives. Obviously the approach differs with the market.

Since the early 1960's Brother has been at the forefront of knitting machine development and came out with a world beater, the model 585 (later modified to the model 588) which has a lace carriage which automatically transfers stitches thus enabling even a beginner to do complex operations involving knitting two

properly. When knitting Fair Isle the two colours are fed through the wool feed together making Fair Isle patterns as easy to knit as plain stocking stitch. This is a great time-saver and greatly increases the neatness of the finished effect when working in two colours. The punch-cards, whether it is a pre-punched card or one of the cards you can punch yourself, takes care of the pattern automatically, all you do is push the carriage. There is nothing to remember. If you require a single motif or column of pattern you can push back needles where you do not require the pattern and it will only appear on the remaining needles. This is the single motif work which has been possible on the Jones machines for almost 10 years, a long way ahead of our rivals who have only just come up with a simple method. Another fantastic feature with this machine is the way Brother have automated the lace carriage so that even a beginner can knit lace patterns without constant reference to charts. The pattern repeat is over 24 needles and very complex lace patterns can be worked out. *Remember* this is a proper

over 24 needles automatically; knit weaving patterns over 24 stitches; easily weave more than two colours in one row.

We are sure this machine will be a world beater. Already even without advertising or announcing its arrival we have sold a considerable number, purely by rumour. This is almost unheard of in previous instances and we look forward to a fantastic boom in sales as the knitting public gets to know about the Jones Knit-O-Matic. For one or two of our customers who have earlier models and wish to part-exchange, we can arrange this through local agents, but bear the following in mind. As a company we do not market machines and constantly bring out new models in the hopes that old customers will part-exchange. When we bring a machine on to the market we are sure that it is the best value at its price at that particular time and if your old machine does sufficient for you, please do not be tempted by sales talk into part-exchanging for a new machine.

It is always nice to have the latest but on the other hand if you do not require pat-

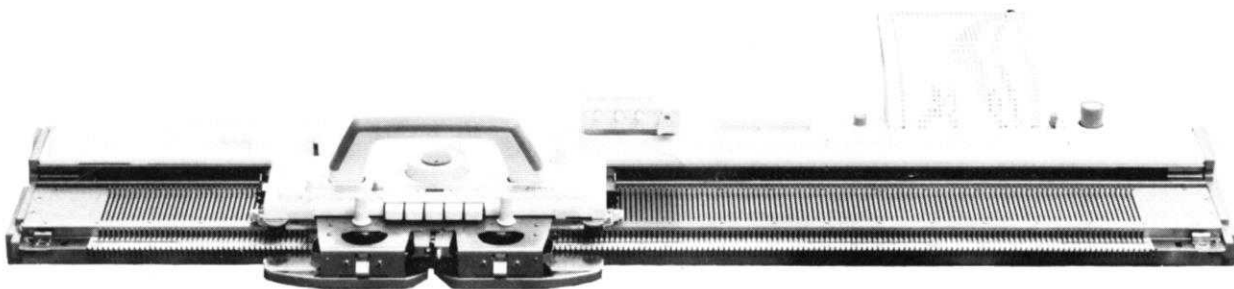

stitches together and making one. These two machines founded the name for reliability and good workmanship which the Brother products have today.

With the market the size of their home market they cannot afford to make mistakes in terms of construction or design as this would be disastrous when you consider the number of machines they sell in Japan. We have the advantage in England of buying the machines after they have been tested on the Japanese market so that 9 times out of 10 all the teething troubles are removed before we receive the machine. This has meant that knitting machines in England have not suffered any serious setbacks from bad design and production in the last 10 years.

Jones are very proud to be able to present the latest in a line of successful machines which we are going to call the Jones Knit-O-Matic (code number 820). This is the best knitting machine available today. After several years of careful research Brother have found the simplest and safest way to produce wonderful knitting for either stocking stitch or fancy patterns. We think the average housewife will be able to knit complex Fair Isle patterns after only a few hours practice, in fact in a matter of minutes if shown

hand knitting stitch to give a genuine knitting of two stitches together and making one and not an attempt to achieve something which looks like it by using invisible thread. It is so much nicer to have baby garments which are soft to the touch and do not have nylon threads in which the baby can catch its fingers.

For quite some time our machines have been able to weave patterns and we have now increased the scope by having the patterns over 24 needles instead of the smaller numbers on earlier models. A big plus to bear in mind with the Jones machine is that many different colours can be woven in one row. For instance if you wish to weave three different colours in one row this is very easy and some striking effects can be obtained. Super textures and colour ways can be achieved in a fabric which in many instances can be treated as an ordinary woven fabric, i.e., it can be cut and sewn.

If you combine the weaving with the lace a whole new range of patterns can be obtained again over 24 needles giving patterns which can only be done on this machine. Some others can do it, but over a very much smaller pattern repeat. So remember the Knit-O-Matic is the only punch-card machine which will knit 'knit two together and make one' patterns

terns over 24 stitches and the other items mentioned in the previous paragraphs, you would merely be losing money in making an exchange. We continue to stock spares for all the models we have sold and will continue to do so in the future. *Stitchin' time* will continue to be produced with patterns for all the different models, although the pictures illustrated may be for the new model only, but with a little working out they can be knitted on the other machines as well.

Should you decide to part-exchange, the following facts must be borne in mind. The only attachments which fit this machine (the Knit-O-Matic) is the ribbing attachment KR810 and the knitleader attachment KL115. The KL115 will not be here in this country until some time in the New Year. Earlier model ribbing attachments and knitleaders cannot be adapted. We are sorry this has to happen, but unfortunately due to the completely new system used in the Knit-O-Matic an adaptor cannot be made. These two new attachments do, however, fit the earlier models. By the time this is published we should have available blank cards, pre-punched cards, puncher sets and stitch pattern books, i.e., similar to the cassette book for the model 800, available for this machine.

# shawl-collared jacket

Ladies' jacket in pull-up stitch with deep looped cuffs and shawl-collar.

**Materials** 28 (30, 32, 34) balls of Wendy Double Knit Nylonised. 6 (6, 7, 7) balls of Wendy town 'n' country. 3 buttons (approx. 1 in. across).

## Measurements

To fit 32 (34, 36, 38) ins. bust.

Finished measurements 34 (36, 38, 40) ins. bust.

Length from back to neck  $25\frac{1}{4}$  ( $25\frac{1}{2}$ ,  $25\frac{3}{4}$ , 26) ins.

Inside sleeve measurement 17 ( $17\frac{1}{2}$ ,  $17\frac{1}{2}$ , 18) ins.

## Tensions

$6\frac{1}{2}$  sts. and 13 Rs. to 1 in. on T9 over pull-up patt. No. 1.

$6\frac{1}{2}$  sts. and  $10\frac{1}{2}$  Rs. to 1 in. on T9 over pull-up patt. No. 2.

$6\frac{1}{2}$  sts. and  $9\frac{1}{2}$  Rs. to 1 in. on T9 over weave (loop) patt. No. 3.

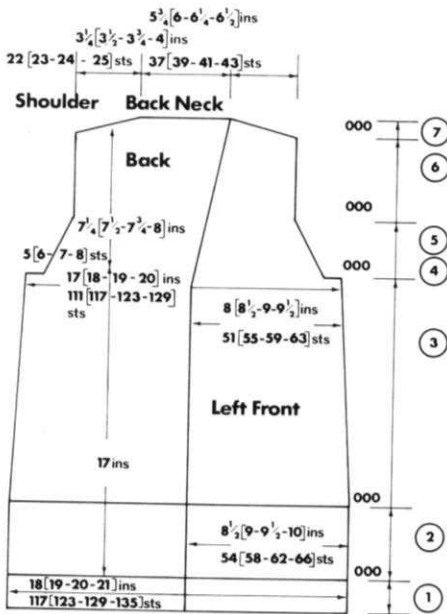

## JACKET BACK

**Step 1.** In D.K. C.O.B.H. 117 (123, 129, 135) sts. T8. K. 19 Rs. T10. K. 1. C.O.R. 000.

**Step 2.** Start patt. No. 1 from graph. K. 54 Rs. T9. C.O.R. 000.

**Step 3.** Start patt. No. 2 from graph. Dec. 1 st. on each edge ev. 40 Rs. 3 times. K. to 136 Rs.

**Step 4.** C/O. 5 (6, 7, 8) sts. at beg. next 2 Rs. C.O.R. 000.

**Step 5.** Dec. 1 st. on each edge ev. 3 Rs. 10 times. To 81 (85, 89, 93) sts. 30 Rs. C.O.R. 000.

**Step 6.** K. 44 (48, 52, 56) Rs. straight. C.O.R. 000.

**Step 7. Note** Whilst knitting shoulders, instead of changing H.C.L.'s to 1(3) as on graph, push pattern Ns. to C pos.) Always taking Y. round inside N. in E pos., push 5 Ns. to E pos. at opp. end to carr. on next 8 Rs. Then push 2 (3, 4, 5) Ns. to E pos. on next

2 Rs. Return Ns. on Lt. to C pos. H.C.L.'s II. K. 1. H.C.L. I(3). K. 1. C/O. shoulders. Thread-up back neck sts. and take off M/c.

## LEFT FRONT

Cast on to right of centre. Slide dial on 6.

**Step 1.** In D.K. C.O.B.H. 54 (58, 62, 66) sts. Cont. as for back to step 3.

**Step 3.** As for back to 126 Rs. Mark edge Lt. st. with contrast-coloured wool. Dec. this st. then dec. 1 st. on Lt. edge ev. 7 (6, 6, 6) Rs. 8 (15, 9, 3) times. Then ev. 6 (0, 5, 5) Rs. 5 (0, 8, 16) times. At the same time after 136 Rs. start step 4.

**Step 4.** C/O. 5 (6, 7, 8) sts. on Rt. edge. K. 2 Rs. C.O.R. 000.

**Step 5.** Dec. 1 st. on Rt. Edge ev. 3 Rs. 10 times. To 30 Rs. C.O.R. 000.

**Step 6.** K. 44 (48, 52, 56) Rs. C.O.R. 000.

**Step 7.** K. 1. C.O.L. (See note on back shoulders.) Always taking Y. round inside N. in E pos., push 5 Ns. to E pos. on Rt. edge ev. alt. R. 4 times. Then push 2 (3, 4, 5) Ns. to E pos. K. 2 Rs. C.O.L. H.C.L. I(3). K. 1. C/O.

## RIGHT FRONT

Cast on to left of centre. Slide dial on 3. K. as for left front reversing all shapings.

## SLEEVES (Knit two)

**Step 1.** In D.K. C.O.B.H. 81 (85, 89, 93) sts. T8. K. 19 Rs. T10. K. 1. C.O.R. 000.

**Step 2.** Start patt. No. 3 from graph. T9.

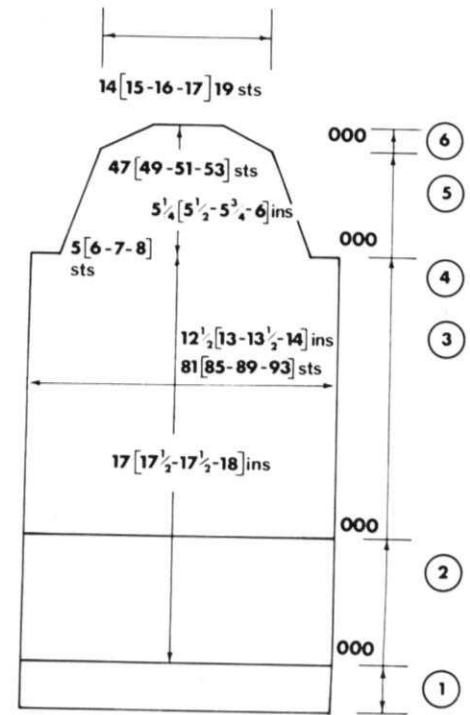
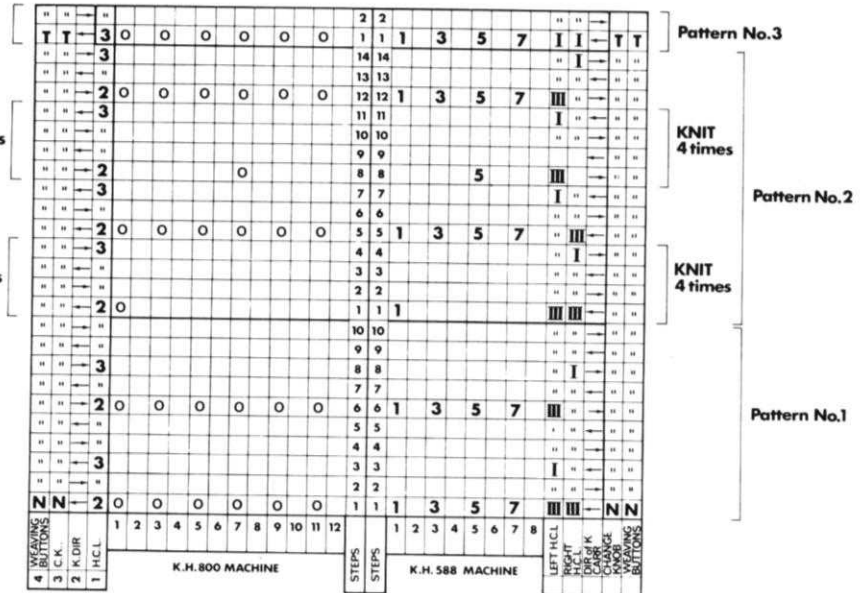

## Loops

\* (Always push each edge N. to C pos.) With town 'n' country, wind yarn over 1st. needle in C pos. and around a ruler (which should be approx.  $1\frac{1}{2}$  ins. deep). Wind over next needle and around ruler. Cont. across M/c. (If rulers are 12 ins. long, two will be needed.) \* K. 48 Rs. of loops. C.O.R. 000.

**Step 3.** Start patt. No. 2 from graph. K. 126 (132, 132, 138) Rs. straight.







# child's bonnet and scarf

**Step 4.** C/O. 5 (6, 7, 8) sts. at beg. next 2 Rs. C.O.R. 000.

**Step 5.** Dec. 1 st. on each edge ev. 4 Rs. 12 times. To 48 Rs. C.O.R. 000.

**Step 6.** See note on step 7 back. Always taking Y. round inside N. in E pos. push 3 Ns. to E pos. at opp. end to carr. on next 4 (8, 8, 6) Rs. Then 4 (3, 2, 2) Ns. to E pos. on next 4 (2, 4, 8) Rs. Return Ns. on Lt. to C pos. H.C.L.'s II. K. 1. H.C.L. I. K. 1. C/O.

## TO MAKE UP

Press all pieces. Join shoulders.

## FRONT BANDS

**Ribbers** In D.K. Cast on 98 sts. as 2 x 2 rib. T4/4. K. 2 Rs. Tub. T8/8. K. 8 Rs. Rib.

\* **Buttonholes** Starting the 5th N. in from right edge make buttonhole over next 6 sts. Leave space of 22 Ns. and make another buttonhole. Repeat making 3 holes in all. (Leaving 32 Ns. on Lt. edge.) \* K. 6 Rs. rib. Trans. Ns. to M.B.

**Single bed M/cs.** In D.K. C.O.B.H. 98 sts. T8. K. 6 Rs. Make buttonholes as \* to \* above. K. 8 Rs. T10. K. 1. T8. K. 8 Rs. Make buttonholes as before. K. 6 Rs. M.D.E. With right side of work facing M/c., place right front up to marked stitch, evenly onto Ns. On left edge fold back hem and place onto 12 Ns. C/O. to end. Repeat band omitting buttonholes and place left front onto Ns. and C/O. to end.

## COLLAR

In D.K. C.O.B.H. 173 (179, 185, 191) sts. K. 1. C.O.L. H.C.L.'s II. Always taking Y. round inside N. in E pos. T8. Push 30 Ns. to E pos. at opp. end to carr. on next 2 Rs. Return 1 N. to C pos. at opp. end to carr. on next 60 Rs. (63 Rs. in all). T10. (For 810 M/cs. set M/c. for weave patt. from graph.) K. 1. C.O.R. 000. Start weave patt. No. 3. See \* to \* of sleeves, loops. T9. Always taking Y. round inside N. in E pos. push 30 Ns. to E pos. at opp. end to carr. on next 2 Rs. Return 1 N. to C pos. at opp. end to carr. on next 60 Rs. C.O.B. K. 1 row of loops. C.O.L. 63 Rs. With W. WI. K. a few Rs. Take collar off M/c. With purl side of work facing M/c. replace collar on to Ns. Fold up collar with loop side facing you. M.D.E. With wrong side of jacket facing M/c., place side neck onto 68 (70, 72, 74) Ns. Back neck to 37 (39, 41, 43) Ns. to rest of jacket to rem. Ns. C/O. in D.K. to end. Sew tops of sleeves into armholes. Press seams. Join side and sleeves seams. Fold back hems and pin in place. Slip-st. Finish off buttonholes. Press all seams, collar and front bands. Sew on buttons to correspond with holes.



## Materials

3 50-grm. balls of Patons Cameo Crepe 4 ply in White and 1 ball of the same yarn in a random shade for contrast. A small flower loom.  $\frac{3}{4}$  yard narrow White ribbon.

## Measurements

To fit 2 to 4 years

## Tension

T8. 15 sts. and 20 rows to 2 ins.

## Abbreviations

K., knit; sts., stitches; trans., transfer; T., tension; M.B., main bed; alt., alternate; beg., beginning; 000., set row counter to 000; M., white; C., random contrast.

## Note

This garment was knitted on a machine with ribbing attachment.

## SCARF

### TO MAKE

With M, cast on 66 sts. by hand. T8. 000. K. 100 rows. Join in C. \* With C, K. 4 rows. With M, K. 100 rows. Repeat from \* twice more. Cast off.

### TO MAKE UP SCARF

Press on the wrong side with a warm iron over a damp cloth. Join row ends of scarf on the wrong side, turn right side out, then neatly over-sew each end.

## FRINGE

Cut 4 strands of C each 7 ins. long, fold in half and knot through end of scarf. Make 8 more tassels in the

same way and knot at equal distances apart. Work along opposite end of scarf to match. With small flower loom make 8 daisies using C and st. 4 to each end of scarf, 2 on either side.

## BONNET

### FRONT

With M, cast on 97 sts. as 1 x 1 rib T6/6. Work 6 rows with M. K. 4 rows with C. Repeat the last 10 rows once more. Break off C. K. 10 rows with M. Trans. ribber sts. to M.B. 000. T8. K. 50 rows—increasing 1 st. at beg. of first row—98 sts.

### To Shape Back

Cast off 34 sts. at each side of needle-bed. On 30 sts. K. 50 rows. Cast off.

### TO MAKE UP BONNET

Press as for scarf omitting ribbing. Join the cast off groups of 34 sts. to each side of back section. Turn front brim back to second C stripe and catch in place at both sides. With wrong side facing pick up 97 sts. evenly from along lower edge of bonnet and place on machine. Trans. alt. sts. to ribber. T6/6. K. 2 rows with M. K. 4 rows with C. K. 2 rows with M. Cast off loosely. Make 3 small daisies with flower loom. Cut ribbon in half and st. to each side of bonnet with a daisy. St. the remaining daisy to centre of front brim.



# polo necked jumper and cardigan

## Materials

**Cardigan** 8 (9, 10, 11) balls of colour A. EMU Scotch Superwash wool in 4 ply. 3 balls of B. EMU Scotch Superwash wool in 4 ply. 2 balls of C. EMU Scotch Superwash wool in 4 ply. 5 buttons.

**Jumper** 4 balls of colour A. EMU Scotch Superwash wool in 4 ply. 2 balls of B. EMU Scotch Superwash wool in 4 ply. 7 (8, 9, 10) balls of C. EMU Scotch Superwash wool in 4 ply.

## Measurements

To fit 30 (32, 34, 36) ins. bust.

Finished measurement 31 (33, 35, 37) ins. bust.

Sleeve seam 17 (17, 17½, 17½) ins.

Cardigan length from back neck 21 (21¼, 21½, 21¾) ins.

Jumper length from back neck 19 (19¼, 19½, 19¾) ins.

## Tension

7 sts. and 10½ Rs. to 1 in. on T8 over st.st. on 810 M/c.

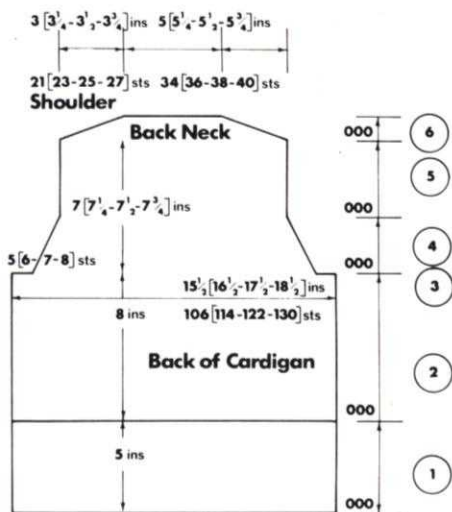

## CARDIGAN

### BACK

**Step 1. Ribbers** In colour A. Cast on 107 (115, 123, 131) sts. as 1 x 1 rib. \* T0/O. K. 4 Rs. Tub. T2/2. K. 56 Rs. rib. Trans. Ns. to M.B. Dec. 1 st. on Rt. edge. \*

**Single bed M/cs.** In colour A. C.O.B.H. 106 (114, 122, 130) sts. \* T5. K. 58 Rs. T7. K. 1. T5. K. 58 Rs. M.D.E. T8. K. 1. \* C.O.R. 000. T8.

**Step 2. (Stripe sequence** Colour B. K. 4 Rs. Colour A. K. 4. Colour C. K. 4.) Repeat stripe sequence to 48 Rs. Change to colour B. K. 11 Rs. Set M/c. to jacq. K. 1. K. 32 Rs. of jacq. K. 12 Rs. plain in colour B. Starting with colour A, repeat stripe sequence to end of piece.

**Step 3.** At the same time after 84 Rs. C/O. 5 (6, 7, 8) sts. at beg. next 2 Rs. C.O.R. 000.







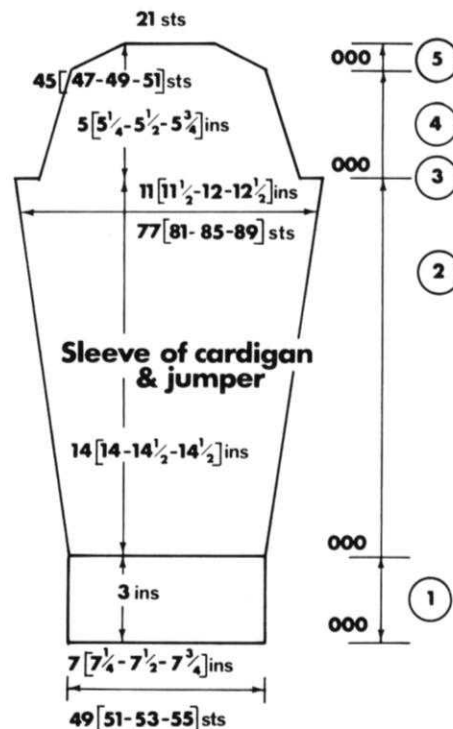

front to step 5.

**Step 5.** K. 42 (46, 50, 54) Rs. straight. C.O.R. 000.

**Step 6.** Thread-up centre 20 sts. and take off M/c. Push Ns. on Lt. to E pos. H.C.L.'s II. \* On neck edge dec. 1 st. ev. R. 7 (8, 9, 10) times. At the same time work shoulder as for front step 6. \* Return Ns. on Lt. to B pos. and K. as \* to \* reversing all shapings.

#### SLEEVES

**Step 1.** K. as for cardigan. Cont. to end of sleeve in colour C, as for cardigan.

#### TO MAKE UP

Press all pieces. Join shoulders. Sew tops of sleeves into armholes. Press seams. Join side and sleeve seams.

#### POLO-NECK

**Ribbers** In colour A. Cast on 113 (117, 121, 125) sts. as 1 x 1 rib. T0/O. K. 2 Rs. Tub. T2/2. K. 84 Rs. rib. Trans. Ns. to M.B. With Rt. side of work facing M/c. Place  $\frac{1}{2}$  front neck to 10 Ns. Place side neck to 36 (38, 40, 42) Ns. C/O. up to this point. Place B.N. to 20 Ns. and rem. of neck to rest of Ns. C/O. in colour B to end.

**Single bed M/cs.** In colour A. C.O.B.H. 112 (116, 120, 124) sts. T5. K. 24 Rs. T7. K. 1. T5. K. 24 Rs. M.D.E. Place Lt. side neck to 36 (38, 40, 42) Ns. Place front neck to 20 Ns. C/O. in colour B up to this point. Place side neck to 36 (38, 40, 42) Ns. and B.N. to rem. Ns. C/O. to end. Close seam. At front neck join ribbed neck for  $1\frac{1}{2}$  ins. Press side and sleeve seams, and collar seam. Fold ribbed collar to outside.



# man's shawl-collar jumper

Man's jumper featuring plain sleeves and check-cross jacquard bodice pieces. Shawl-collar buttons down front.

## Materials

9 (9, 9, 10, 10) ozs. of M. Wl. In 4 ply wool by Debbie Anne. 9 (9, 9, 10, 10) ozs. of Contrast Wl. In 4 ply wool by Debbie Anne. 3 buttons.

## Measurements

To fit 34 (36, 38, 40, 42) ins. chest.  
Sleeve seams 17½ (18, 18, 18½, 18½) ins.  
Length from shoulder 22½ (22¾, 23, 23¼, 23½) ins.

## Tensions

8 sts. and 9½ Rs. to 1 in. on T7½ over jacquard.

7 sts. and 10½ Rs. to 1 in. on T6¾ over st.st.

## Using Jacquard No. 1

■ = Punched Hole

⊗ = Unpunched Hole

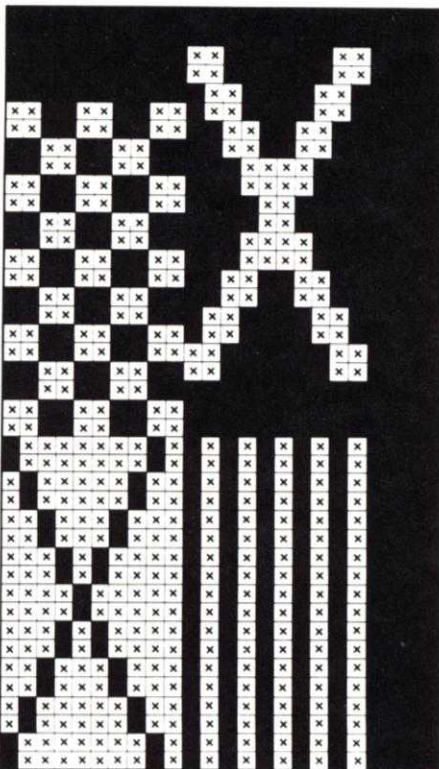

JACQUARD NO1

## BACK AND FRONT

(3 sts. extra on Left than on right.)

**Step 1. Ribbers** In M. Wl. Cast on 141 (149, 157, 165, 173) sts. as 1 x 1 rib. T0/0. K. 4 Rs. Tub. T3/3. K. 27 Rs. rib. Trans. Ns. to M.B.

**Single bed M/cs.** With W. Wl. Cast onto 141 (149, 157, 165, 173) sts. K. a few Rs. Trans. ev. alt. N. to Rt. Push empty Ns. back to A pos. Change to M. Wl. T5. K. 30 Rs. T7. K. 1. T5. K. 30 Rs. M.D.E. Unravel W. Wl. C.O.L. T6¾. Set M/c. for jacq. K.



1. C.O.R. 000. Dec. 1 st. on Lt. edge.

**Step 2.** Start jacq. T7¾.

## BACK

K. 114 Rs. straight.

**Step 3.** C/O 5 (6, 7, 8, 9) sts. at beg. next 2 Rs. C.O.R. 000.

**Step 4.** Dec. 1 st. on each edge ev. 3 Rs. 11 times. K. to 34 Rs. C.O.R. 000.

**Step 5.** K. 44 (46, 48, 50, 52) Rs.

straight. C.O.R. 000.

**Step 6.** H.P. \* Push 7 (7, 8, 8, 9) Ns. to E pos. at opp. end to carr. on next 4 Rs. Then 7 (8, 8, 9, 9) Ns. to E pos. on next 4 Rs. Return Ns. on Lt. to C pos. K. 1. Return Ns. on Rt. to C pos. K. 1. C/O shoulders. Thread-up Back Neck sts. and take off M/c.



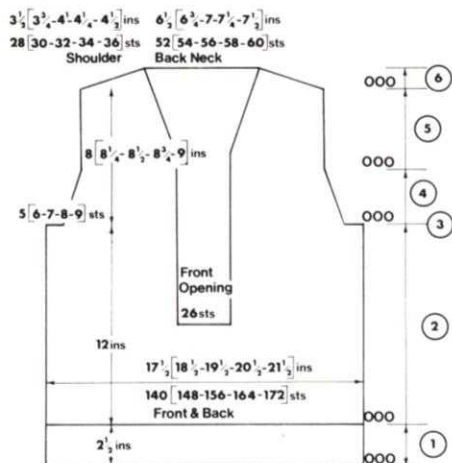

### FRONT OPENING

**Step 2.** K. 57 Rs. straight. C/O 26 sts. at centre of work. H.P. Push Ns. on Lt. to E pos. On Rt. front, cont. to 114 Rs.

**Step 3.** C/O 5 (6, 7, 8, 9) sts. on Rt. edge. K. 2 Rs. C.O.R. 000.

**Step 4.** Shape Rt. armhole as for back. **At the same time** After 20 Rs. on Lt. edge dec. 1 st. ev. 5 Rs. 10 (8, 6, 4, 2) times. Then ev. 4 Rs. 2 (5, 8, 11, 14) times.

**Step 6.** K. 1. C.O.L. H.P. \* Push 7 (7, 8, 8, 9) Ns. to E pos. on Rt. edge ev. alt. R. 2 times. Then 7 (8, 8, 9, 9) Ns. to E pos. ev. alt. R. twice. Return Ns. on Rt. to C pos. K. 1. C/O. Return Lt. front Ns. to B pos. and set for jacq. Cont. as for Rt. front, reversing all shapings.

### SLEEVES

**Step 1. Ribbers** In M. Wl. Cast on 55 (59, 63, 67, 71) sts. as 1 x 1 rib.

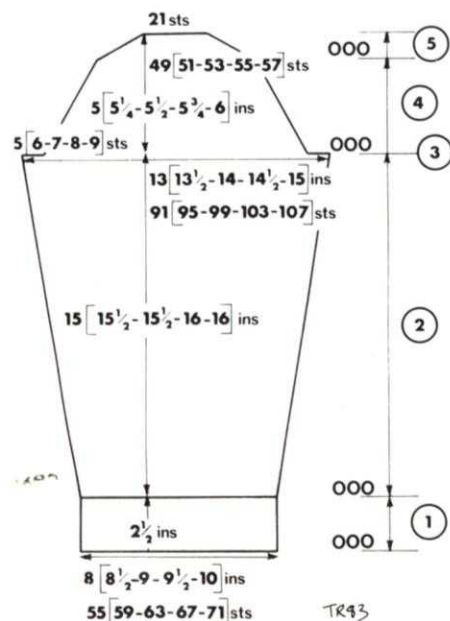

T0/0. K. 4 Rs. Tub. T3/3. K. 28 Rs. rib. Trans. Ns. to M.B.

**Single bed M/cs.** With W. Wl. Cast onto 55 (59, 63, 67, 71) sts. K. a few Rs. Trans. ev. alt. N. to Rt. Push empty Ns. back to A pos. Change to M. Wl. T5. K. 31 Rs. T7. K. 1. T5. K. 31 Rs. M.D.E. Remove W. Wl. C.O.L. T6 2/3. K. 1. C.O.R. 000.

**Step 2.** Change to C. Wl. for rem. sleeve. Inc. 1 st. on each edge ev. 8 (8, 8, 9, 9) Rs. 18 times. K. to 156 (162, 162, 168, 168) Rs.

**Step 3.** C/O 5 (6, 7, 8, 9) sts. at beg. next 2 Rs. C.O.R. 000.

**Step 4.** Dec. 1 st. on each edge ev. 3 Rs. 16 times. K. to 48 Rs. C.O.R. 000.

**Step 5.** H.P. \* Push 5 (4, 4, 3, 3) Ns. to E pos. at opp. end to carr. on next 4 (6, 2, 10, 8) Rs. Then 4 (3, 3, 2, 2) Ns. to E pos. on next 2 (2, 8, 2, 6) Rs. Return Ns. on Lt. to C pos. K. 1. Return Ns. on Rt. to C pos. K. 1. C/O. Repeat sleeve.

### TO MAKE UP

Press all pieces. Join shoulders. Sew tops of sleeves into armholes. Press seams. Join side and sleeve seams.

### RIGHT HALF OF COLLAR

**Ribbers** In M. Wl. Cast onto 135 (137, 139, 141, 143) sts. as 1 x 1 rib. T0/0. K. 4 Rs. Tub. T3/3. K. 43 Rs. rib. Trans. Ns. to M.B.

**Single bed M/cs.** With W. Wl. Cast onto 135 (137, 139, 141, 143) sts. K. a few Rs. Trans. ev. alt. N. to Rt. Push empty Ns. back to A pos. Change to M. Wl. T5. K. 46 Rs. T7. K. 1. T5. K. 46 Rs. M.D.E. Unravel W. Wl. With right side of work facing M/c., and starting 1 st. in from each edge, place Rt. half of Back Neck to 27 (28, 29, 30, 31) sts., place side neck to 52 (53, 54, 55, 56) sts., and front opening to rem. 56 sts. C/O to end.

### LEFT HALF OF COLLAR

**Ribbers** After 8 Rs. of 1 x 1 rib, starting the 12th st. in from Rt. edge, cast off 5 sts. \* Leave space of 11 sts. C/O next 5 sts. \* Repeat \* to \*. Cont. to 43 Rs. Trans. Ns. to M.B.

**Single bed M/cs.** After 38 Rs., make B'holes as for ribber band. Cont. to 46 Rs. T7. K. 1. T5. K. 8 Rs. Repeat B'holes. K. to 93 Rs. M.D.E. Unravel W. Wl. Starting 1 st. in from each edge, place right front to collar as before and C/O. Join collar at back neck. Sl.st. Rt. edge of collar to front. Catch-down left edge of collar to wrong side. Finish off buttonholes. Press all seams and collar. Sew on buttons. Catch-down collar in place.

Man's polo-necked jumper featuring saddle-shoulders and check-cross patterned front and back.

### Materials

13 (14, 15, 16, 17) ozs. of Kingfisher 4 ply Wool Crepe by Debbie Anne. 4 (4, 5, 5, 6) ozs. of White 4 ply Wool Crepe by Debbie Anne.

### Measurements

To fit 34 (36, 38, 40, 42) ins. chest. Sleeve seam 17 1/2 (18, 18, 18 1/2, 18 1/2) ins.

Length from shoulder 21 (21 1/4, 21 1/2, 21 3/4, 22) ins.

### Tensions

7 1/2 sts. and 11 Rs. to 1 in. on T6 2/3 over st.st.

8 sts. and 10 Rs. to 1 in. on T7 2/3 over jacq.

### Using Jacquard No. 1

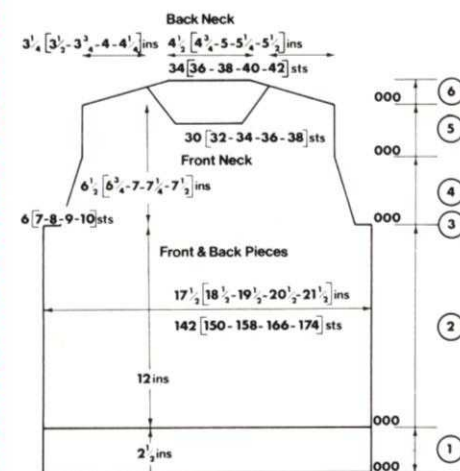

### BACK AND FRONT

**Step 1. Ribbers** In M. Wl. cast on 143 (151, 159, 167, 175) sts. as 1 x 1 rib. (Note 2 Ns. extra to Lt. of centre than to Rt. of centre.) \* T0/0. K. 4 Rs. Tub. T3/3. K. 27 Rs. rib. Trans. Ns. to M.B. Dec. 1 st. on Lt. \*

**Single bed M/cs.** With W. Wl. Cast onto 143 (151, 159, 167, 175) sts. K. a few Rs. Trans. ev. alt. N. to Rt. Push empty Ns. back to A pos. Change to M. Wl. \* T5. K. 30 Rs. T7. K. 1. T5. K. 30 Rs. M.D.E. Unravel W. Wl. Dec. 1 st. on Lt. \* C.O.L. T6 2/3. Set M/c. for jacq. K. 1. row. C.O.R. 000.

**Step 2.** Start jacq. (with contrast colour in main feeder, main colour in jacq. feeder). T7 2/3. K. 120 Rs. straight.

**Step 3.** C/O 6 (7, 8, 9, 10) sts. at beg. next 2 Rs. C.O.R. 000.

**Step 4.** Dec. 1 st. on each edge ev. 4 Rs. 10 times. To 40 Rs. C.O.R. 000.

**Step 5. Back Neck only** K. 26 (28, 30, 32, 34) Rs. to shoulder.

**Step 6. Shoulders** H.P. \* Push 5 (6, 6, 7, 7) Ns. to E pos. at opp. end of carr. on next 8 Rs. Then push 5 (4, 5,



# man's polo neck jumper



4, 5) Ns. to E pos. on next 4 Rs. Then 4 Ns. to E pos. on next 4 Rs. Push Ns. on Lt. back to C pos. K. 1. Push Ns. on Rt. to C pos. K. 1. C/O.

**Step 5. Front Neck only** K. 18 (20, 20, 22, 22) Rs. to front neck. Thread-

up centre 30 (32, 34, 36, 38) sts. and take off M/c. H.P. Push Ns. to Lt. of centre to E pos. \* On Rt. neck edge, dec. 1 st. ev. alt. R. 2 (4, 4, 6, 6) times. Then ev. R. 12 (10, 10, 8, 8) times.

■ = Punched Hole  
 x = Unpunched Hole

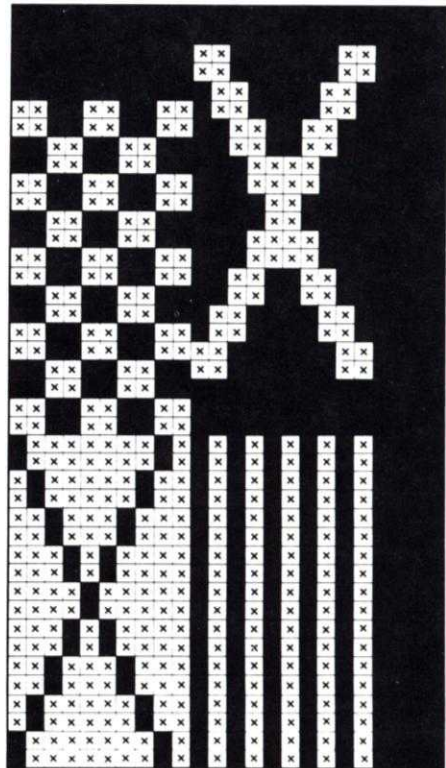

JACQUARD NO 1

**At the same time** work shoulder. H.P. \* After 27 (29, 31, 33, 35) Rs. C.O.L. Push 5 (6, 6, 7, 7) Ns. to E pos. on Rt. edge ev. alt. R. 4 times. Then 6 (4, 6, 4, 6) Ns. to E pos. once. C.O.L. Push Ns. to C pos. K. 1. C/O. \* Return Ns. on Lt. to B pos. and set for jacq. Repeat from \* to \* reversing all shapings.

## SLEEVES

**Step 1. Ribbers** In M. Wl. cast on 61 (65, 69, 73, 77) sts. as 1 x 1 rib. K. as \* to \* of bodices.

**Single bed M/cs.** In W. Wl. Cast on 61 (65, 69, 73, 77) sts. K. a few Rs. Trans. ev. alt. N. to Rt. Push empty Ns. back to A pos. Change to M. Wl. K. as from \* to \* of bodices. C.O.L. T6  $\frac{2}{3}$ . K. 1. C.O.R. 000.

**Step 2.** Start stripe sequence. C. Wl. K. 2 Rs. M. Wl. K. 14 Rs. C. Wl. K. 2 Rs. M. Wl. K. 14 Rs. C. Wl. K. 2 Rs.

**At the same time** Inc. 1 st. on each edge ev. 9 Rs. 18 times. K. to 96 (100, 104, 108, 112) Rs.

**Step 3.** C/O 6 (7, 8, 9, 10) sts. at beg. next 2 Rs. C.O.R. 000.

**Step 4.** Dec. 1 st. on each edge ev. 3 Rs. 17 times. K. to 52 Rs. C.O.R. 000.

**Step 5.** H.P. \* Push 5 (4, 3, 3, 3) Ns. to E pos. at opp. end of carr. on next 4 (6, 6, 8, 4) Rs. Then 4 (3, 3, 2, 2) Ns. to E pos. on next 2 (2, 4, 4, 10) Rs. Return Ns. on Lt. to C pos. K. 1. C/O Lt. 14 (15, 15, 16, 16) sts.



# man's cardigan and top

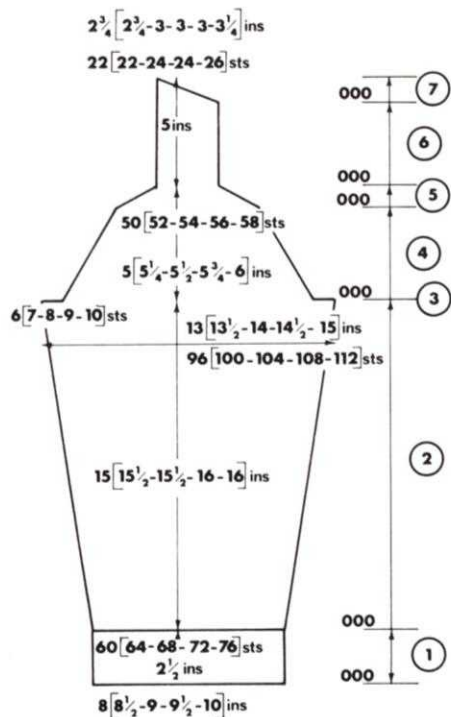

Return Ns. on Rt. to C pos. K. 1. C/O these sts. Leaving 22 (22, 24, 24, 26) sts. on M/c. C.O.R. 000.

**Step 6.** K. 40 (42, 44, 46, 48) Rs. straight. C.O.R. 000.

**Step 7.** K. 1. C.O.L. H.P. \* Push 5 sts. to E pos. on Rt. edge ev. alt. R. 2 (2, 4, 4, 4) times. Then 4 (4, 4, 4, 6) sts. to E pos. ev. alt. R. 3 (3, 1, 1, 1) times. C.O.L. Push Ns. to C pos. K. 1. C/O.

**Repeat sleeve to step 7.** Repeat as before reversing all shapings.

## TO MAKE UP

Press all pieces. Sew tops of sleeves to armholes, joining shorter edges (see step 6) to front and longer edges to back. Join tops of sleeves (see step 7). Press seams. Join side and sleeve seams.

## POLO NECK

In M. Wl. cast on 149 (153, 161, 165, 173) sts. as 1 x 1 rib.

**Ribbers** T0/O. K. 4 Rs. Tub. T3/3. K. 68 Rs. rib. Trans. Ns. to M.B.

**Single bed M/cs.** With W. Wl. Cast onto 149 (153, 161, 165, 173) sts. K. a few Rs. Trans. ev. alt. N. to Rt. Push empty Ns. back to A pos. T5. K. 38 Rs. T7. K. 1. T5. K. 38 Rs. M.D.E. Unravel W. Wl. With Rt. side of work facing M/c., place Lt. sleeve to 20 (20, 22, 22, 24) Ns. Place side of front neck to 22 Ns., front neck to 30 (32, 34, 36, 38) Ns. C/O up to this point. Place side neck and sleeve to Ns. as before, and back neck to rem. Ns. C/O to end. Press collar lightly under wet cloth. Close collar seam. Press all seams. Catch collar down in place.

Man's cardigan featuring plain sleeves and jacquard bodice pieces. Worn with matching top with square-shaped neckline. Both in optical pattern.

## Materials

**Cardigan** 11 (12, 13, 14, 15) ozs. Main colour. Debbie Anne 4 ply Crepe Wool. 9 (9, 9, 10, 10) ozs. Contrast colour. Debbie Anne 4 ply Crepe Wool. 5 buttons.

**Vest Top** 5 (5, 5, 6, 6) ozs. Main Colour. Debbie Anne 4 ply Crepe Wool. 6 (7, 7, 8, 8) ozs. Contrast colour. Debbie Anne 4 ply Crepe Wool.

## Measurements

To fit 34 (36, 38, 40, 42) ins. chest. Sleeve seams 17 1/2 (18, 18, 18 1/2, 18 1/2) ins.

Length of cardigan from shoulder 26 1/2 (26 3/4, 27, 27 1/4, 27 1/2) ins.



Length of vest top from shoulder  $22\frac{1}{4}$  ( $22\frac{1}{2}$ ,  $22\frac{3}{4}$ , 23,  $23\frac{1}{4}$ ) ins.

### Tensions

$7\frac{1}{2}$  sts. and 11 Rs. to 1 in. on  $T6\frac{2}{3}$  over st.st.

$7\frac{1}{2}$  sts. and 10 Rs. to 1 in. on  $T7\frac{2}{3}$  over jacquard.

### Using Jacquard No. 2

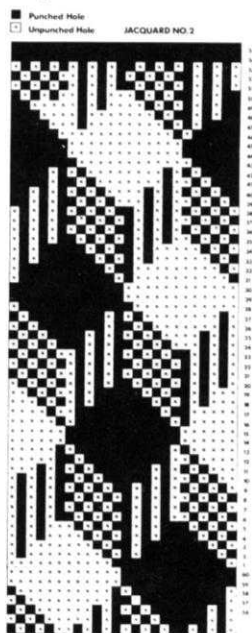

Shoulder:  $3\frac{1}{2}$ ,  $3\frac{1}{2}$ ,  $3\frac{1}{2}$ ,  $4$  ins  
 Back Neck:  $6\frac{1}{2}$ ,  $6\frac{1}{2}$ ,  $7\frac{1}{4}$ ,  $7\frac{1}{4}$  ins  
 22 24-26-28-30 sts 48 50-52-54-56 sts

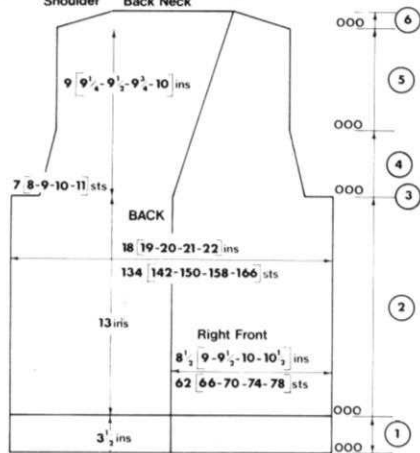

### CARDIGAN—BACK

**Step 1. Ribbers** In C. Wl. Cast on 135 (143, 151, 159, 167) sts. as 1 x 1 rib. \* T0/O. K. 4 Rs. Tub. T3/3. K. 30 Rs. rib. Change to M. Wl. K. 5 Rs. rib. Trans. Ns. to M.B. Dec. 1 st. \*

**Single bed M/cs.** With W. Wl. Cast onto 135 (143, 151, 159, 157) sts. K. a few Rs. Change to M. Wl. Trans. ev. alt. N. to Rt. Push empty Ns. back to A pos. \* T5. K. 6 Rs. Change to C. Wl. K. 32 Rs. T7. K. 1. T5. K. 32 Rs. Change to M. Wl. K. 6 Rs. M.D.E. Unravel W. Wl. Dec. 1 st. \* C.O.L.  $T6\frac{2}{3}$ . Set M/c. for jacq. K. 1. C.O.R. 000.

**Step 2.**  $T7\frac{2}{3}$ . Start jacq. K. 130 Rs. straight.

**Step 3.** C/O 7 (8, 9, 10, 11) sts. at beg. next 2 Rs. C.O.R. 000.

**Step 4.** Dec. 1 st. on each edge ev. 3 Rs. 14 times. K. to 42 Rs. C.O.R. 000.

**Step 5.** K. 50 (52, 54, 56, 58) Rs. straight. C.O.R. 000.

**Step 6.** H.P. \* Push 4 (5, 5, 6, 6) Ns. to E pos. at opp. end to carr. on next 8 Rs. Then 6 (4, 6, 4, 6) Ns. to E pos. on next 2 Rs. Return Ns. on Lt. to C pos. K. 1. Return Ns. on Rt. to C pos. K. 1. C/O shoulders. Thread-up back neck sts. and take off.

### RIGHT FRONT

Start the 6th N. to Rt. of centre. (i.e. miss 5 Ns.)

**Step 1. Ribbers** In C. Wl. Cast on 63 (67, 71, 75, 79) sts. as 1 x 1 rib. K. as \* to \* of back.

**Single bed M/cs.** With W. Wl. Cast onto 63 (67, 71, 75, 79) sts. K. a few Rs. Trans. ev. alt. N. to Rt. Push empty Ns. to A pos. Change to M. Wl. K. as \* to \* of back. C.O.L.  $T6\frac{2}{3}$ . Set M/c. for jacq. K. 1. C.O.R. 000.

**Step 2.**  $T7\frac{2}{3}$ . K. 114 Rs. straight. Mark Lt. edge st. with contrast coloured Wl. Dec. this st. Then dec. 1 st. on Lt. edge ev. 6 Rs. 18 (17, 14, 11, 8) times. Then ev. 5 Rs. 0 (2, 6, 10, 14) times.

At the same time Work Rt. side shaping as for back to step 6.

**Step 6.** K. 1. C.O.L. H.P. \* Push 4 (5, 5, 6, 6) Ns. to E pos. on Rt. edge ev. alt. R. 4 times. Then 6 (4, 6, 4, 6) Ns. to E pos. once. C.O.L. Push Ns. back to C pos. K. 1. C/O.

### LEFT FRONT

Starting the 6th N. to Lt. of centre, K. as for right front, reversing all shapings.

### SLEEVES

**Step 1. Ribbers** In C. Wl. cast on 59 (63, 67, 71, 75) sts. as 1 x 1 rib. T0/O. K. 4 Rs. Tub. T3/3. K. 30 Rs. rib. Trans. Ns. to M.B. C.O.R. 000.

**Single bed M/cs.** With W. Wl. Cast onto 59 (63, 67, 71, 75) sts. K. a few Rs. Change to C. Wl. T5. K. 32 Rs. T7. K. 1. T5. K. 32 Rs. M.D.E. Unravel W. Wl.  $T6\frac{2}{3}$ . K. 1. C.O.R. 000.

**Step 2.** Inc. 1 st. on each edge ev. 8 (8, 8, 9, 9) Rs. 19 times. K. to 164 (170, 170, 176, 176) sts.

**Step 3.** C/O 6 (7, 8, 9, 10) sts. at beg. next 2 Rs. C.O.R. 000.

**Step 4.** Dec. 1 st. on each edge ev. 4 Rs. 1 (3, 5, 7, 9) times. Then ev. 3 Rs. 12 (10, 8, 6, 4) times. K. to 40 (42, 44, 46, 48) Rs. C.O.R. 000.

**Step 5.** H.P. \* Push 4 Ns. to E pos. at opp. end to carr. on next 10 Rs. Return Ns. on Lt. to C pos. K. 1. Return Ns. on Rt. to C pos. K. 1. C/O.

### TO MAKE UP

Press all pieces. Join shoulders.

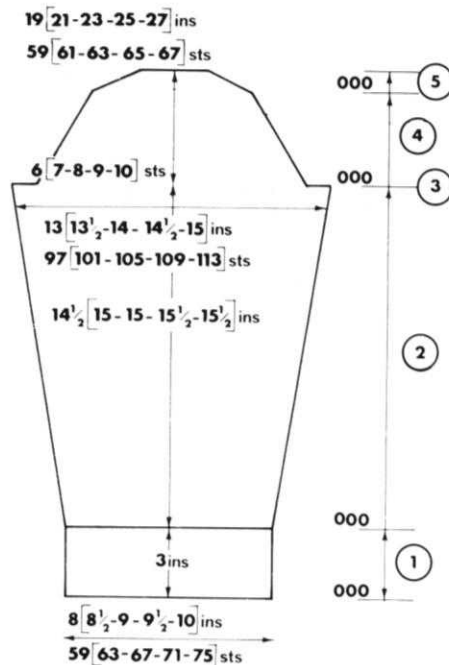

### ARMBANDS

In C. Wl. C.O.B.H. 144 (148, 152, 156, 160) sts.  $T6\frac{2}{3}$ . K. 14 Rs. C/O. Repeat. Press. Pin bands to tops of sleeves and sl.st. in place. Pin other edge to armholes and sl.st. Press seams. Join side and sleeve seams.

### BUTTONHOLE BAND

In M. Wl. C.O.B.H. 187 (190, 193, 196, 199) sts. T5. K. 5. Change to C. Wl. K. 7 Rs. \* Starting the 4th N. in from the Rt. edge make B'hole over 7 sts. Leave space of 13 Ns. between holes, make 5 holes in all. \* K. 7 Rs. T7. K. 1. T5. K. 7 Rs. Repeat B'holes. K. 12 Rs. M.D.E. With Rt. side of work facing M/c., place  $\frac{1}{2}$  back neck to first 24 (25, 26, 27, 28) Ns. Place side neck, (up to marked st.) to next 75 (77, 79, 81, 83) sts., and front to 68 Ns., and rib to 20 Ns. C/O up to rib in M. Wl. and rib in C. Wl. Repeat band omitting holes. Join bands at back neck. Finish off B'holes. Press all seams and bands. Sew on buttons.

### VEST TOP

#### FRONT AND BACK

**Step 1. Ribbers** In C. Wl. Cast on 131 (139, 147, 155, 163) sts. as 1 x 1 rib. T0/O. K. 4 Rs. Tub. T2/2. K. 35 Rs. rib. Trans. Ns. to M.B. Dec. 1 st.

**Ribbers** In W. Wl. Cast onto 131 (139, 147, 155, 163) sts. K. a few Rs. Trans. ev. alt. N. to Rt. Push empty Ns. back to A pos. Change to C. Wl. T5. K. 37 Rs. T7. K. 1. T5. K. 37 Rs. M.D.E. Unravel W. Wl. C.O.L.  $T6\frac{2}{3}$ . Set M/c. to jacq. K. 1. C.O.R. 000.

**Step 2.**  $T7\frac{2}{3}$ . Start jacq. with C. Wl. in main feeder, and M. Wl. in jacq. feeder. K. 96 Rs.

**Step 3.** Thread-up 26 (27, 30, 31,





**Step 6.** K. as before reversing shapings for other shoulder. \*

**FRONT NECK**

K. 50 Rs. straight. K. as for back neck from \* to \*.

**TO MAKE UP**

Press pieces. Join shoulders and side seams.

**Back and Front Neck Ribs**

**Ribbers** In C. Wl. Cast on 37 (39, 41, 43, 45) sts. as 1 x 1 rib. \* TO/O. K. 4 Rs. Tub. T3/3. Inc. 1 st. on each edge ev. alt. R. 10 times. K. to 22 Rs. Trans. Ns. to M.B. Dec. 1 st. \*

**Single bed M/cs.** With W. Wl. Cast onto 57 (59, 61, 63, 65) sts. K. a few Rs. \* Trans. ev. alt. N. to Rt. Push empty Ns. back to A pos. Change to C. Wl. \* T5. Dec. 1 st. on each edge ev. alt. R. 12 times, to 24 Rs. T7. K. 1. T5. Inc. 1 st. on each edge ev. alt. R. 12 times. To 49 Rs. M.D.E. Unravel W. Wl. Dec. 1 st. \* With Rt. side of work facing M/c., starting 1 st. in from each edge, place front neck to sts. and C/O. Repeat for back neck.

**SIDE NECKBANDS**

**Ribbers** In C. Wl. Cast on 35 (37, 39, 41, 43) sts. as 1 x 1 rib K. rib as for front neck \* to \*.

**Single bed M/cs.** With W. Wl. cast onto 55 (57, 59, 61, 63) sts. K. a few Rs. K. as for front from \* to \*. With Rt. side of work facing M/c., starting 1 st. in from each edge, place side neck evenly onto Ns. and C/O. Repeat for other side.

**Lower Armbands**

**Ribbers** Cast on 41 (43, 49, 51, 57) sts. as 1 x 1 rib. \* TO/O. K. 4 Rs. Tub. T3/3. Inc. 1 st. on each edge ev. alt. R. 7 times. K. to 16 Rs. Trans. Ns. to M.B. Dec. 1 st. \*

**Single bed M/cs.** With W. Wl. Cast onto 55 (57, 63, 65, 71) sts. K. a few Rs. \* Trans. ev. alt. N. to Rt. Push empty Ns. back to A pos. Change to C. Wl. T5. Dec. 1 st. on each edge ev. alt. R. 9 times. T7. K. 1. T5. Inc. 1 st. on each edge ev. alt. R. 9 times. To 37 Rs. M.D.E. Unravel W. Wl. Dec. 1 st. \* With Rt. side of work facing M/c., starting 1 st. in from each edge, place under arm to Ns. and C/O. Repeat.

**Side Armbands**

**Ribbers** Cast on 123 (127, 131, 135, 139) sts. as 1 x 1 rib. K. as for lower armbands from \* to \*.

**Single bed M/cs.** With W. Wl. Cast onto 137 (141, 145, 149, 153) sts. K. a few Rs. K. as for lower armbands as \* to \*. With Rt. side of work facing M/c., starting 1 st. in from each edge, place armhole evenly onto Ns. and C/O. Repeat. Join all mitres. Press all seams and bands.

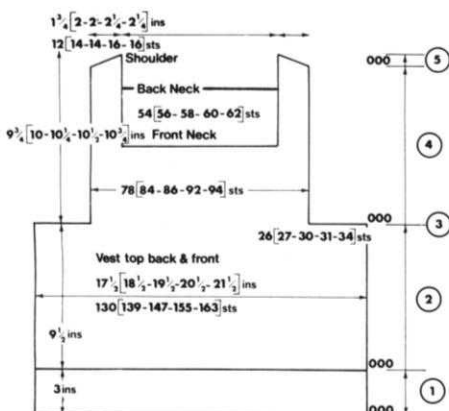

34) sts. on each edge and take off M/c. C.O.R. 000.

**Step 4. Back only** K. 86 Rs. straight. \* Thread-up centre 54 (56, 58, 60, 62) sts. and take off M/c. Push Ns. on Lt. to E pos. H.P. K. to 98 (100, 102, 104, 106) Rs. C.O.R. 000.

**Step 5.** K. 1. C.O.L. H.P. \* Push 4 (5, 5, 6, 6) Ns. to E pos. on Rt. edge ev. alt. R. twice. Then 4 (4, 4, 5, 5) Ns. to E pos. once. C.O.L. Push Ns. back to C pos. K. 1. C/O. Return Ns. on Lt. to B pos. and set for jacq. C.O.R. 086. K. to 98 (100, 102, 104, 106) Rs. C.O.R. 000.



# man's jumper and waistcoat

Man's waistcoat in optical jacquard, worn over jumper with 'herringbone' pattern at waist and cuffs.

## Materials

**Waistcoat** 8 (8, 8, 9, 9) balls of Main Colour. Debbie Anne 4 ply Wool Crepe. 5 (5, 5, 6, 6) ozs. of contrast colour. Debbie Anne 4 ply Wool Crepe. 5 buttons.

**Jumper** 5 ozs. of Main Colour. Debbie Anne 4 ply Wool Crepe. 9 (10, 10, 11, 11) ozs. of contrast wool. Debbie Anne 4 ply Wool Crepe.

## Measurements

To fit 34 (36, 38, 40, 42) ins. chest.

Inside sleeve seams 17½ (18, 18, 18½, 18½) ins.

Length of waistcoat from shoulder 25 (25¼, 25½, 25¾, 26) ins.

Length of jumper from shoulder 22½ (22¾, 23, 23¼, 23½) ins.

## Tensions

7½ sts. and 11 Rs. to 1 in. over st.st. on T6¾.

7½ sts. and 10 Rs. and 1 in. over main jacquard on T7¾.

7½ sts. and 8½ Rs. and 1 in. over jumper jacquard on T7¾.

**Waistcoat: using Jacquard No. 2.**

**Jumper: using Jacquard No. 2A.**

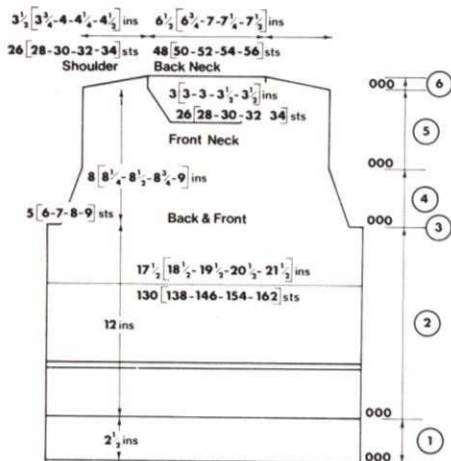

## WAISTCOAT—BACK

**Step 1. Ribbers** In M. Wl. Cast on 135 (143, 151, 159, 167) sts. as 1 x 1 rib. \* T/O. K. 4 Rs. Tub. T3/3. K. 31 Rs. rib. Trans. Ns. to M.B. \*

**Single bed M/cs.** With W. Wl. Cast onto 135 (143, 151, 159, 167) sts. K. a few Rs. \* Trans. ev. alt. N. to Rt. Push empty Ns. back to A pos. Change to M. Wl. \* T5. K. 34 Rs. T7. K. 1. T5. K. 34 Rs. M.D.E. Unravel W. Wl. \* C.O.L. Set M/c. for jacq. T6¾. K. 1. C.O.R. 000. Dec. 1 st.

**Step 2.** T7¾. Start jacq. K. 126 Rs. straight.

**Step 3.** C/O 11 (12, 13, 14, 15) sts. at beg. next 2 Rs. C.O.R. 000.

**Step 4.** Dec. 1 st. on each edge ev. 5 Rs. 8 times. To 40 Rs. C.O.R. 000.

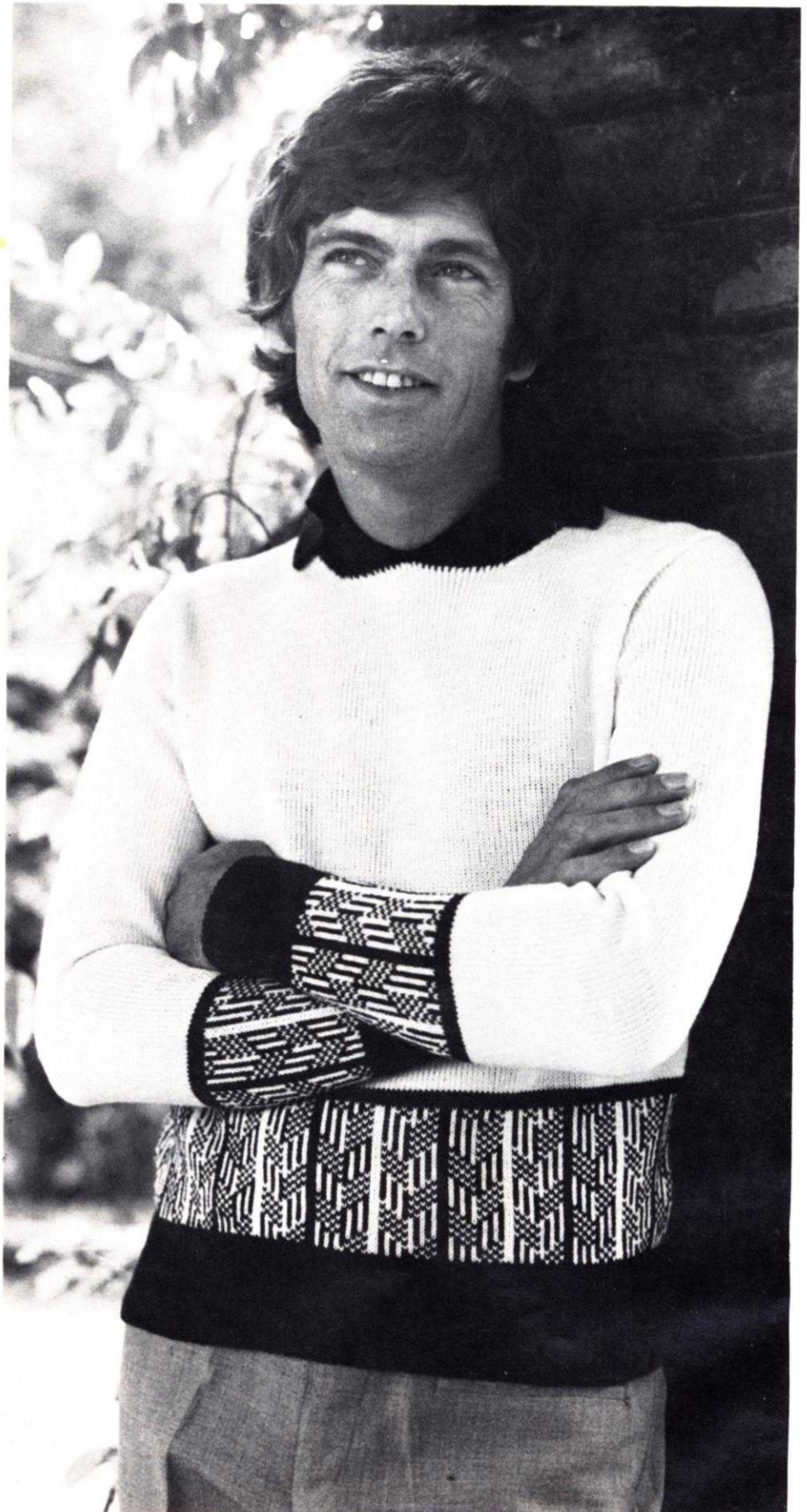



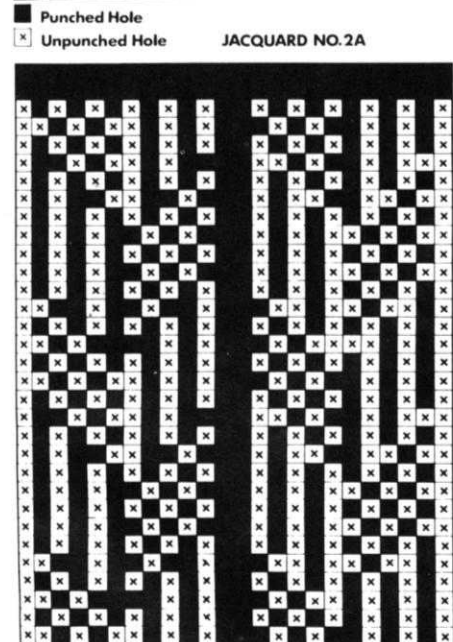
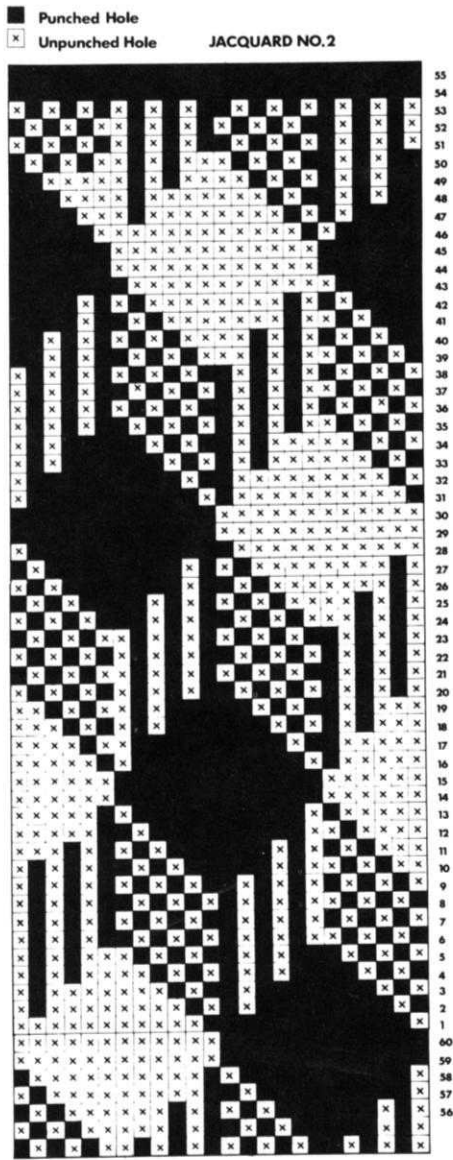

**Step 5.** K. 60 (62, 64, 66, 68) Rs. straight. C.O.R. 000.

**Step 6.** H.P. \* Push 4 (5, 5, 6, 6) Ns. to E pos. at opp. end to carr. on next 8 Rs. Then 6 (4, 6, 4, 6) Ns. to E pos. on next 2 Rs. C.O.R. Return Ns. on Lt. to C pos. K. 1. Return Ns. on Rt. to C pos. K. 1. C/O to end.

**RIGHT FRONT**  
Start the 6th N. to Rt. of centre (i.e. miss 5 Ns.).

**Step 1. Ribbers** In M. Wl. Cast on 63 (67, 71, 75, 79) sts. as 1 x 1 rib. K. as \* to \* of back.

**Single bed M/cs.** With W. Wl. Cast onto 63 (67, 71, 75, 79) sts. K. a few Rs. K. as \* to \* of back. C.O.L. Set M/c. for jacq. T6 $\frac{2}{3}$ . K. 1. C.O.R. 000. Dec. 1 st. on Rt. edge.

**Step 2.** K. 126 Rs. straight.  
**Step 3.** On Rt. edge C/O 11 (12, 13, 14, 15) sts. K. 2 Rs. C.O.R. 000. On Lt. edge mark edge st. with C. Wl. Dec. this st. Then on neck edge dec. 1 st. ev. 5 Rs. 20 (18, 16, 14, 12) times. Then ev. 4 Rs. 0 (3, 6, 9, 12) times.

**At the same time** Work Rt. side shapings as for back.

**Step 6.** K. 1. C.O.L. H.P. \* Push 4 (5, 5, 6, 6) Ns. on Rt. edge to E pos. ev. alt. R. 4 times. Then 6 (4, 6, 4, 6) Ns. to E pos. once. Return Ns. to C pos. K. 1. C/O.

**LEFT FRONT**  
Start the 6th N. to Lt. of centre. As for right front up to step 3.

**Step 3.** K. 1. C.O.L. C/O 11 (12, 13, 14, 15) sts. K. 1. C.O.R. 000. On Rt. edge, mark edge st. Cont. as for right reversing shapings.

**Step 6.** C.O.R. H.P. \* Push 4 (5, 5, 6, 6) Ns. to E pos. on Lt. edge ev. alt. R. 4 times. Then 6 (4, 6, 4, 6) Ns. to E pos. Return Ns. to C pos. K. 1. C/O.

**TO MAKE UP**  
Press pieces. Join shoulders.

**ARMBANDS**  
**Ribbers** In M. Wl. Cast on 157 (159, 161, 163, 165) sts. as 1 x 1 rib T0/O. K. 4 Rs. Tub. T3/3. K. 12 Rs. rib. Trans. Ns. to M.B.

**Single bed M/cs.** C.O.B.H. 157 (159, 161, 163, 165) sts. T5. K. 14 Rs. T7. K. 1. T5. K. 14 Rs. M.B.E. With Rt. side of work facing M/c., place armhole evenly onto Ns. and C/O to end.

**ARMBANDS**  
Repeat band. Join side seams.

**RIBBER BAND**  
In M. Wl. Cast on 20 sts. as all-needle rib. T0/O. K. 4 Rs. Tub. T2/2. K. 4 Rs. rib. \* H.P. \* Push 10 Ns. on Lt. edge to E pos. (over both beds). K. 13 Rs. C.O.L. Push 10 Ns. on Rt. edge to E pos. Move carr. to Rt.

Break off Y. and thread between sets of Ns. Return 10 Ns. on Lt. edge to C pos. K. 13 Rs. C.O.L. Return all Ns. to C pos. K. 29 Rs. straight. C.O.R. \* Repeat from \* to \*, making 5 B'holes in all. K. band until long enough to fit up both fronts and across back neck, stretching slightly. C/O.

**Single bed M/cs.** Cast on 18 sts. T5. K. as ribbers, making holes over Ns. 5 and 14. C/O. Sew ribbed front band in pos. Sew st.st. band in pos., turn to inside and slip-st. in place. Finish off B'holes. Press all seams and bands. Sew on buttons.

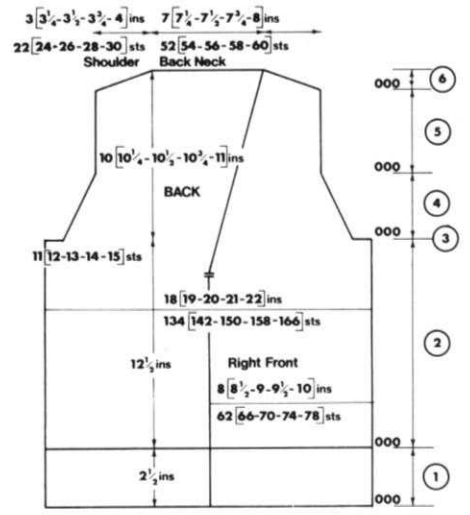

**JUMPER**  
**BACK AND FRONT**

**Step 1. Ribbers** In M. Wl. Cast on 131 (139, 147, 155, 163) sts. as 1 x 1 rib. \* T0/O. K. 4 Rs. Tub. T3/3. K. 31 Rs. rib. Trans. Ns. to M.B. \*

**Single bed M/cs.** With W. Wl. Cast onto 131 (139, 147, 155, 163) sts. K. a few Rs. \* Trans. ev. alt. N. to Rt. Push empty Ns. back to A pos. Change to M. Wl. T5. K. 34 Rs. T7. K. 1. T5. K. 34 Rs. M.D.E. Unravel W. Wl. \* C.O.L. T6 $\frac{2}{3}$ . Set M/c. for jacq. K. 1. C.O.R. 000. Dec. 1 st.

**Step 2.** T7 $\frac{2}{3}$ . Start jacq. from graph. K. 36 Rs. of jacq. K. 4 Rs. st.st. in M. Wl. (cont. in C. Wl.) Cont. to 126 Rs. in all.

**Step 3.** C/O 5 (6, 7, 8, 9) sts. at beg. next 2 Rs. C.O.R. 000.

**Step 4.** Dec. 1 st. on each edge ev. 4 Rs. 10 times. To 40 Rs. C.O.R. 000.

**Step 5. Back** K. 50 (52, 54, 56, 58) Rs. straight. C.O.R. 000.

**Step 6.** H.P. \* Push 5 (6, 6, 7, 7) Ns. to E pos. at opp. end to carr. on next 8 Rs. Then 6 (4, 6, 4, 6) Ns. to E pos. on next 2 Rs. C.O.R. Push Ns. on Lt. to C pos. K. 1. Return Ns. on Rt. to C pos. K. 1. C/O to end.

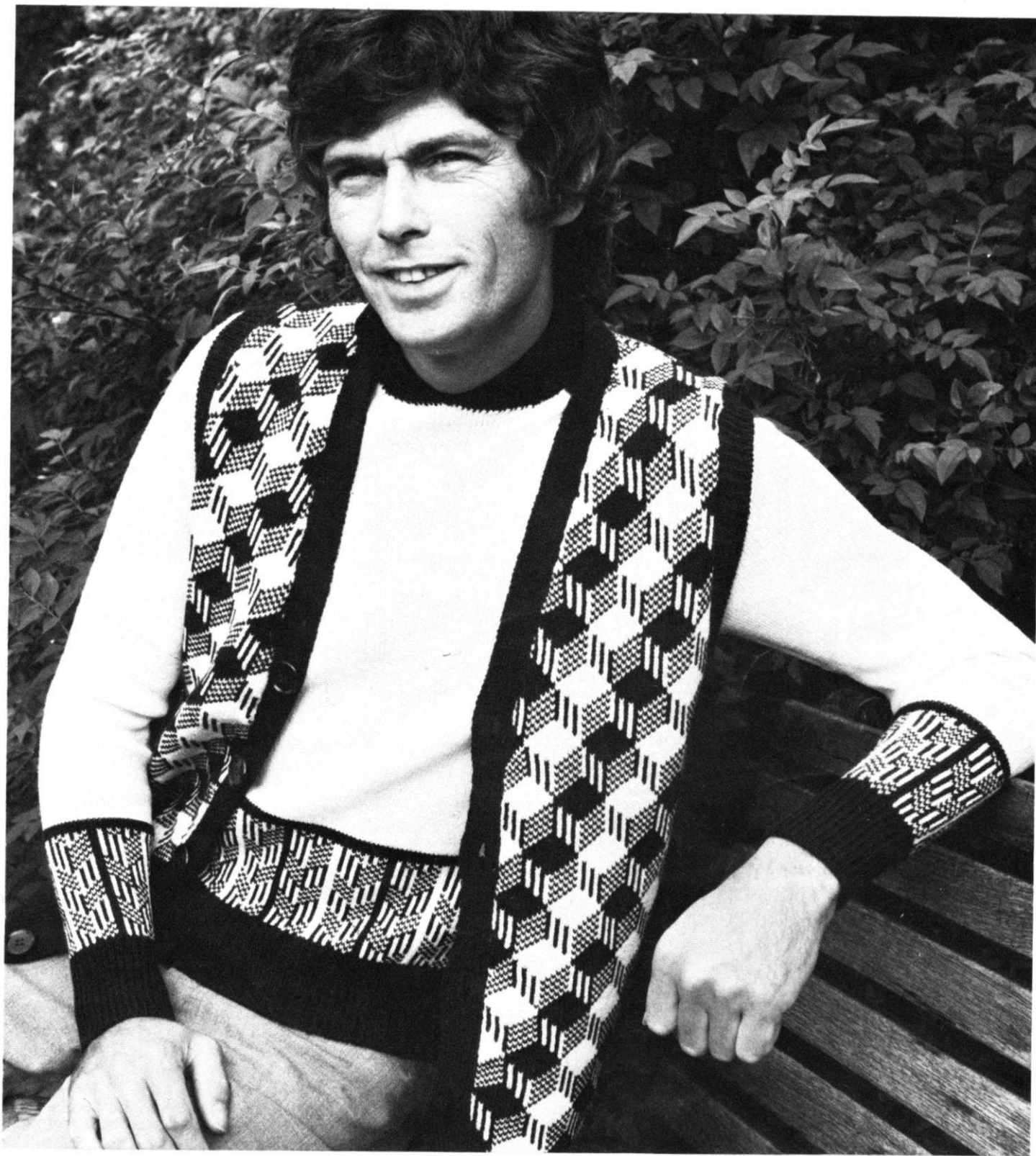

#### FRONT NECK

**Step 5.** K. 28 (30, 32, 30, 32) Rs. to F.N. Thread-up centre 26 (28, 30, 32, 34) sts. and take off M/c. H.P. Push Ns. on Lt. to C pos. On Rt. front neck dec. 1 st. ev. alt. R. 11 times. K. to 50 (52, 54, 56, 58) Rs. C.O.R. 000.

**Step 6.** K. 1. C.O.L. H.P. \* Push 5 (6, 6, 7, 7) Ns. to E pos. on Rt. edge ev. alt. R. 4 times, and 6 (4, 6, 4, 6) Ns. to E pos. once. C.O.L. Return Ns. on Rt. to C pos. K. 1. C/O. Return Ns. on Lt. to C pos. and shape F.N. and shoulder as before, reversing shapings.

#### SLEEVES

**Step 1. Ribbers** In M. Wl. Cast on 59 (63, 67, 71, 75) sts. as 1 x 1 rib. K. as from \* to \* of back.

**Single bed M/cs.** In W. Wl. Cast onto 59 (63, 67, 71, 75) sts. K. a few Rs. K. as \* to \* of back. C.O.L. T6 $\frac{2}{3}$ . Set M/c. for jacq. K. 1. C.O.R. 000.



# boy's jazzy-jumper

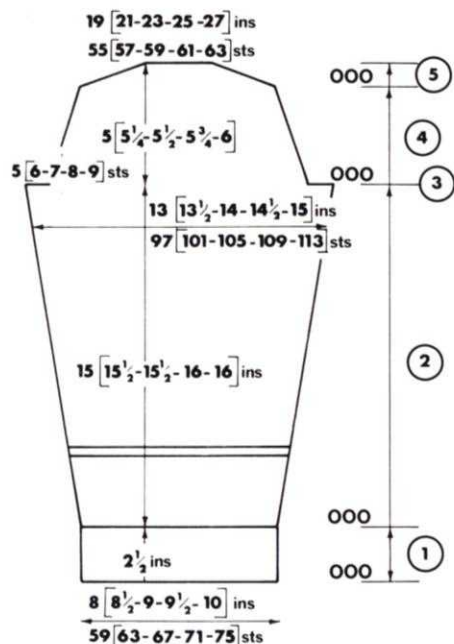

**Step 2.** T7  $\frac{2}{3}$ . Start jacq. K. 36 Rs. K. 4 Rs. st.st. Cont. to end of sleeve in C. Wl. **At the same time** Inc. 1 st. on each edge ev. 8 (8, 8, 9, 9) Rs. 19 times. K. to 164 (170, 170, 176, 176) Rs.

**Step 3.** C/O 5 (6, 7, 8, 9) sts. at beg. next 2 Rs. C.O.R. 000.

**Step 4.** Dec. 1 st. on each edge ev. 3 Rs. 16 times. To 48 Rs. C.O.R. 000.

**Step 5.** H.P. \* Push 6 (5, 4, 3, 3) Ns. to E pos. at opp. end to carr. on next 4 (4, 6, 6, 8) Rs. Then 6 (4, 3, 3, 2) Ns. to E pos. on next 2 (4, 4, 6, 6) Rs. Return Ns. on Lt. to C pos. K. 1. Return Ns. on Rt. to C pos. K. 1. C/O. Repeat sleeve.

## TO MAKE UP

Press all pieces. Join shoulders. Sew tops of sleeves into armholes. Press seams. Join side and sleeve seams.

## COLLAR

**Ribbers** In M. Wl. cast on 117 (121, 125, 133, 137) sts. as 1 x 1 rib. T/O. K. 4 Rs. Tub. T3/3. K. 62 Rs. rib. Trans. Ns. to M.B.

**Single bed M/cs.** In W. Wl. Cast onto 117 (121, 125, 133, 137) sts. K. a few Rs. Trans. ev. alt. N. to Rt. Push empty Ns. back to A pos. Change to M. Wl. T5. K. 70 Rs. T7. K. 1. T5. K. 70 Rs. M.D.E. Unravel W. Wl. With Rt. side of work facing M/c., and starting 1 st. in from each edge, place  $\frac{1}{2}$  front neck to first 14 (15, 16, 17, 18) sts., place side neck to next 20 (20, 20, 22, 22) sts., and back neck to 48 (50, 52, 54, 56) sts. C/O up to this point. Place side neck to 21 (21, 21, 23, 23) sts. and front neck to rem. sts. C/O to end in C. Wl. Close edges of st.st. collar. Press collar and all seams.

## Materials

4 (5, 5, 6, 6) balls of colour A. 5 (5, 6, 6, 7) balls of colour B. 8 (9, 9, 10, 10) balls of colour C. Ferntex acrylic yarn in 4 ply. By Argyll Wools.

## Measurements

To fit 30 (32, 34, 36, 38) ins. chest. Length from shoulder  $22\frac{1}{4}$  ( $22\frac{1}{2}$ ,  $23\frac{1}{4}$ ,  $23\frac{1}{2}$ ,  $23\frac{3}{4}$ ) ins. Inside sleeve measurements 17 ( $17\frac{1}{2}$ ,  $17\frac{1}{2}$ , 18, 18) ins.

## Tensions

$7\frac{1}{2}$  sts. and 10 Rs. to 1 in. on T7 over jacquard.

7 sts. and  $11\frac{1}{2}$  Rs. to 1 in. on T6 over st.st.

## Abbreviations

Jacq. = Jacquard. \* H.C.L.'s II \* = Always take Y. round inside N. in E pos.

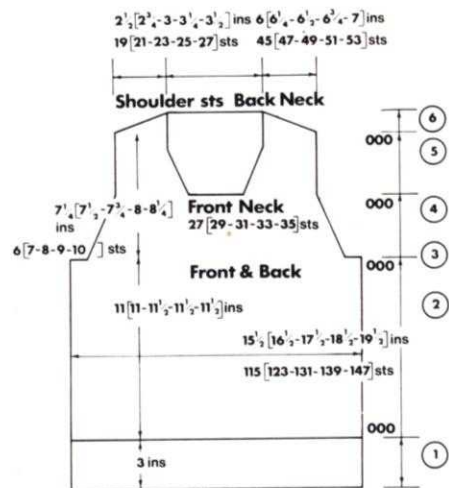

Pattern 3

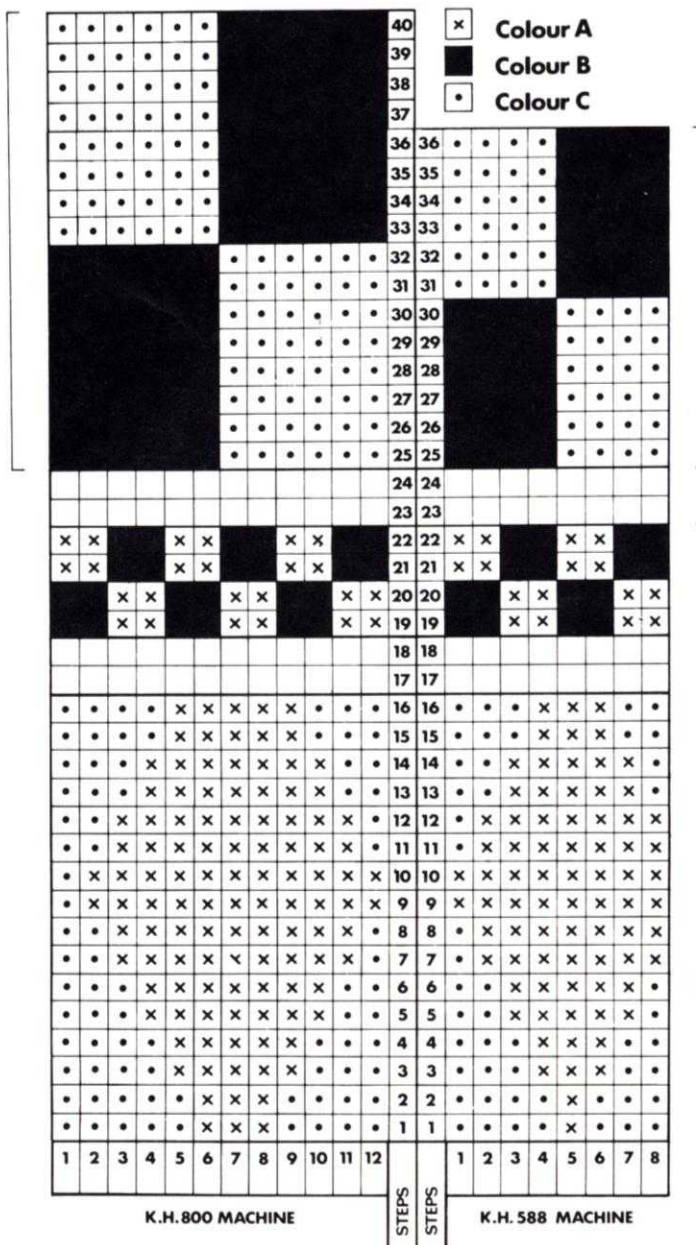

Pattern 3

Pattern 2

Pattern 1

K.H.800 MACHINE

STEPS

K.H.588 MACHINE



### JUMPER BACK

**Step 1. Ribbers** In colour A. Cast on 114 (122, 130, 138, 146) sts. as 2 x 2 rib. \* T1/1. K. 2 Rs. Tub. T3/3. K. 2 Rs. rib. Change to colour B. K. 38 Rs. rib. Trans. Ns. to M.B. \* Inc. 1 st. to 115 (123, 131, 139, 147) sts. C.O.R. 000 \*.

**Single bed M/cs.** In colour B. C.O.B.H. 115 (123, 131, 139, 147) sts. \* T5. K. 38 Rs. T7. K. 1. Change to colour A. T5. K. 4 Rs. Change to B. K. 34 Rs. M.D.E. T6. K. 1. C.O.R. 000.

**Step 2.** T7. In colour C. K. 4 Rs. In colour A. K. 4. In colour B. K. 3. Set M/c. for jacq. K. 66 Rs. of jacq. 1 from graph. In colour B. K. 2 Rs. In colour A. K. 2. In colour C. K. 2. K. 10 Rs. of jacq. 2 from graph. In colour C. K. 2 Rs. In colour A. K. 2. In colour B. K. 2. K. jacq. 3 to end of back.

**At the same time** after 110 (110, 116, 116, 116) Rs.

**Step 3.** C/O 6 (7, 8, 9, 10) sts. at beg. next 2 Rs. C.O.R. 000.

**Step 4.** Dec. 1 st. on each edge ev. 4 Rs. 10 times. To 40 Rs. C.O.R. 000.

**Step 5.** K. 34 (36, 38, 40, 42) Rs. straight.

**Step 6.** \* H.C.L.'s II \* Push 3 (4, 4, 5, 5) Ns. to E pos. at opp. end to carr. on next 2 (8, 4, 4, 6) Rs. Then push 4 (5, 5, 5, 6) Ns. to E pos. on next 8 (2, 6, 6, 4) Rs. Push Ns. on Lt. to C pos. K. 1. H.C.L. I. K. 1. C/O shoulders. Thread-up back neck sts.

### FRONT

K. as for back to end of step 4.

**Step 5.** Thread-up centre 27 (29, 31, 33, 35) sts. and take off M/c. Push sts. on Lt. to E pos. H.C.L.'s II.

### Right Shoulder

Dec. 1 st. on Lt. edge ev. 3 Rs. 9 times. K. to 34 (36, 38, 40, 42) Rs. C.O.R. 000.

**Step 6.** K. 1. \*Always taking Y. round inside N. in E pos. push 3 (4, 4, 5, 5) Ns. to E pos. at opp. end to carr. ev. alt. R. 1 (4, 2, 2, 3) times. Then push 4 (5, 5, 5, 6) Ns. to E pos. ev. alt. R. 4 (1, 3, 3, 2) times. C.O.L. Return Ns. by hand to B pos. K. 1. C/O.

### Left Shoulder

Return Lt. Ns. to B pos. and set for jacq. Dec. 1 st. on Rt. edge ev. 3 Rs. 9 times. K. to 34 (36, 38, 40, 42) Rs. C.O.R. 000.

**Step 6.** K. as for right shoulder from \* to \*. H.C.L. I. K. 1. C/O.

### SLEEVES

**Step 1. Ribbers** In colour A. Cast on 50 (54, 58, 62, 66) sts. as 2 x 2 rib. K. as from \* to \* of back. Step 1. Dec. 1 st. to 49 (53, 57, 61, 65) sts. C.O.R. 000.

**Single bed M/cs.** In colour B. C.O.B.H. 49 (53, 57, 61, 65) sts. Make welt as from \* to \* of back. Step 1.

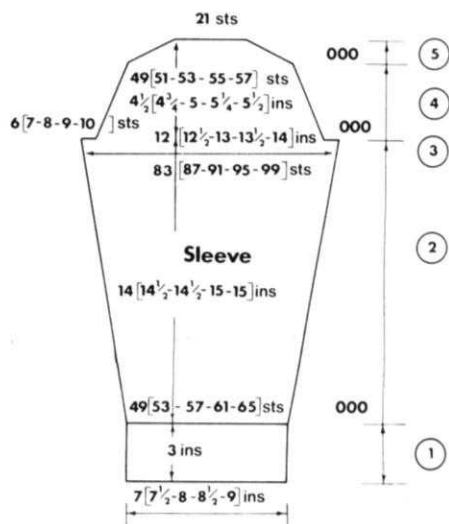

**Step 2.** T6. In colour C. K. 4 Rs. Change to colour A. K. 4 Rs. In colour B. K. 4 Rs. Change to colour C.



# babies rompers .....

**At the same time** Inc. 1 st. on each edge ev. 9 (9, 9, 10, 10) Rs. 17 times. After 132 (138, 132, 138, 138) Rs. Change to colour B. K. 2 Rs. In colour A. K. 2 Rs. In colour C. K. 1. Set M/c. to jacq. K. 1. K. 10 Rs. of jacq. 2. T7. From graph. T6. Change to colour C. K. 2 Rs. In colour A. K. 2 Rs. In colour B. K. 2 Rs. Change to colour A to end of sleeve. K. to 160 (166, 166, 172, 172) Rs.

**Step 3.** As for back.

**Step 4.** Dec. 1 st. on each edge ev. 4 Rs. 11 times. To 44 Rs. C.O.R. 000.

**Step 5.** \* H.C.L.'s II \* Push 3 Ns. to E pos. at opp. end to carr. on next 8 (8, 8, 6, 4) Rs. Then push 2 (3, 4, 4, 4) Ns. to E pos. on next 2 (2, 2, 4, 6) Rs. Push Ns. on Lt. to C pos. K. 1. H.C.L. I. K. 1. C/O. Repeat sleeve.

## TO MAKE UP

Press all pieces. Join shoulders. Sew tops of sleeves into armholes. Press seams. Close side and sleeve seams.

## NECKBAND

In colour C. C.O.B.H. 128 (136, 144, 152, 160) sts. T5. K. 8 Rs. T7. K. 1. T5. K. 8. M.D.E. With right side of work facing M/c., place side neck to 28 (30, 32, 34, 36) Ns. Place front neck to next 27 (29, 31, 33, 35) Ns. C/O up to this point. Place side neck to next 28 (30, 32, 34, 36) Ns. and back neck to rem. Ns. C/O to end. Close band seam. Press.

## COLLAR

**Ribbers** In colour C. Cast on 90 (94, 98, 102, 106) sts. as 2 x 2 rib. T1/1. K. 2 Rs. Tub. T6/6. K. 20 Rs. rib. Trans. Ns. to M.B. C/O loosely.

**Single bed M/cs.** In colour C. C.O.B.H. 70 (74, 78, 82, 86) sts. T5. K. 52 Rs. T7. K. 1. T5. K. 52 Rs. M.D.E. C/O loosely. Press collar flat. Pin in pos. around neck. On inside of jumper, st. to neckband seam.

## COLLAR

**Ribbers** In colour C. Cast on 90 (94, 98, 102, 106) sts. as 2 x 2 rib. T1/1. K. 2 Rs. Tub. T6/6 rib 20 Rs. T5/5 rib 14 Rs. Cast off 6 sts. at beg. of next 4 Rs. and 4 sts. at beg. of following 2 Rs. Cast off loosely.

**Single bed M/cs.** In colour C. C.O.B.H. 90 (94, 98, 102, 106) sts. T4. K. 14 Rs. T5. K. 40 Rs. T4. K. 14 Rs. M.D.E. C/O loosely. Press collar flat.

## TO MAKE UP

Press all pieces. Join left shoulder and neckband. Set in sleeves. Join side and sleeve seams. Fold neckband in half to wrong side and st. in pos. Pin collar in pos. around neck. On inside of jumper, st. to neckband seam.



## Materials

Robin Tricel Nylon Perle 4 ply.  
Rompers 2 ozs. Col. D. 1 oz. each of A, B and C.

Pinafore 4 ozs. Col. A.

Dress 1 oz. B, C and D. ½ in. elastic.

## Measurements

Rompers 16 (18, 20) ins. chest.

Pinafore Dress 18 (20, 22) ins. chest.

## Tension

7½ sts. and 17 Rs. to 1 in. on T5 tuck st.

8 sts. and 12½ Rs. to 1 in. on T5 st.st.

## ROMPERS

Back and front alike to step 4.

1. C.O.B.H. 19 (23, 27) sts.

2. Inc. 1 st. on each edge ev. alt. R. 18 (20, 22) times. Then inc. 1 st. each edge ev. R. 6 times to 67 (75, 83) sts. K. to 42 (46, 50) Rs.

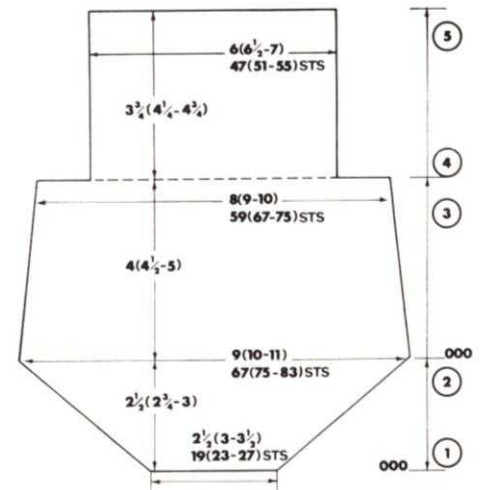









# Jones

*all around your home*

## this Christmas

Are your children at college or university? Does your husband spend evenings writing reports longhand? Are you a part-time secretary at home? Well, here's the ideal Christmas present for all these situations – a Brother portable typewriter.

Brother, a large part of the Jones Sewing Machine organisation, have for many years been one of the market leaders in portable typewriters. Brother machines are of smart, modern design, smooth adjustable touch and sharp alignment – built to last, built to stand up to the most rugged punishment. And now we offer you the model 800T at a really attractive price.

**Save £22.04**

on the recommended price, but hurry this is a once only special offer.



RECOMMENDED RETAIL PRICE £47.99

**Special Offer Price**

**£25.95**

+ 50p Postage and Packing

- Two colour ribbon, black, red and stencil.
- Touch control adjustment to suit all users.
- Automatic ribbon reverse.
- Duo-purpose margin release and jammed key release.
- Half space mechanism for insertions and corrections.
- Left and right shift lock release keys.
- 3 stage linespacing 1-1½-2.
- Standard English keyboard.
- Elite type 11-1".

Plus the extra facility of a pre-set tabulator with 8 fixed positions.

Please send me one model 800T typewriter at £25.25 + 50p postage and packing.

Name \_\_\_\_\_

Address \_\_\_\_\_

\_\_\_\_\_

To: **Stitchin' Time Typewriter Offer, Jones Sewing Machine Co. Ltd.,  
Britannia House, 964 High Road, Finchley, London N12 8LE.**

OFFER APPLIES TO U.K. MEMBERS ONLY.

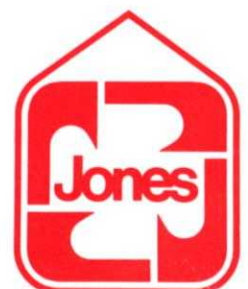

*all around your home*



## his 'n' hers crew necked jumpers





Man's polo-necked and Lady's crew-necked matching jumpers. Featuring lace/rib pattern on bodice pieces and ribbed sleeves.

### Materials

**Crew-necked style** 24 (26, 28, 30, 32, 34) ozs. M. Wl. Templetons Double Scotch pure wool. Small ball C. Wl. Templetons Double Scotch pure wool. 4 buttons if desired.

**Polo-necked style** 25 (27, 29, 31, 33, 35) ozs. M. Wl. Templetons Double Scotch pure wool. Small ball C. Wl. Templetons Double Scotch pure wool.

### Measurements

To fit 32 (34, 36, 38, 40, 42) ins. bust or chest.

Finished measurements 34 (36, 38, 40, 42, 44) ins. bust or chest.

Length from shoulder 23 (23½, 25, 25½, 26¼, 27) ins.

Sleeve seams 17 (17½, 18, 18, 18½, 18½) ins.

### Tensions

9 sts. and 8½ Rs. to 1 in. on T8/7 over 1 x 1 rib.

8 sts. and 9 Rs. to 1 in. on T8/7 over lace/rib patt.

### Abbreviations

\* H.C.L.'s II \* = Always take Y. round inside N. in E pos.

### Note

When knitting 1 x 1 rib set half-pitch lever to pos. 'P' on rib bed.

### Needle-arrangement for lace/rib patt.

Set Ns. as below to Rt. of centre, reverse to Lt. of centre. 7 (10, 13, 16, 19, 22) sts.

(1) Set half-pitch lever to pos. 'H'.

(2) Set the racking indicator to No. 5.

\* T8/7. K. 7 Rs. Trans. the sts. on the 'O' Ns. to the Δ Ns. in the above figure and move the carr. to Rt. Then hook the yarn across onto the empty 'O' Ns. \* Repeat from \* to \*.

### BACK

In M. Wl. cast on 137 (145, 153, 161, 169, 177) sts. as 1 x 1 rib (odd st. on Lt.).

**Step 1.** T7/6. K. 4 Rs. Tub. T8/7. K. 18 Rs. rib. Dec. 1 st. on Lt. edge. Set Ns. for lace/rib patt. (see note). C.O.R. 000.

**Step 2.** K. 134 (134, 144, 144, 154, 154) Rs. straight.

**Step 3.** C/O 5 (6, 7, 8, 9, 10) sts. at beg. next 2 Rs. C.O. R. 000.

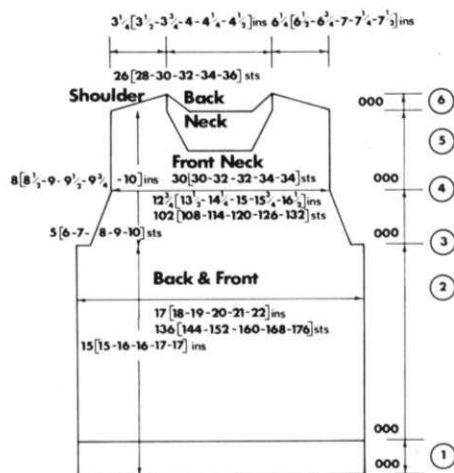

**Step 4.** Dec. 1 st. on each edge ev. 3 Rs. 12 times. To 36 Rs. C.O.R. 000.

**Step 5.** K. 34 (38, 43, 48, 50, 52) Rs. straight to Back Neck. H.C.L.'s II. Thread-up centre 30 (30, 32, 32, 34, 34) sts. and take off M/c. Push Ns. on Lt. to E pos. Dec. 1 st. on neck edge ev. R. 10 (11, 11, 12, 12, 13) times. After 36 (40, 44, 50, 54) Rs. C.O.R. 000.

### SHOULDER

K. 1 C.O.L. \* H.C.L.'s II \* Push 6 (8, 6, 8, 6, 8) sts. to E pos. on Rt. edge ev. alt. R. once. Then 5 (5, 6, 6, 7) sts. to E pos. ev. alt. R. 4 times. Return Ns. to C pos. K. across. C/o. Return Lt. sts. to M/c. and repeat neck decs. and shoulder shapings as before reversing shapings. C/O.

### FRONT

As for back to step 5.

**Step 5.** K. 16 (18, 22, 26, 28, 28) Rs. straight. H.C.L.'s II. Thread-up centre 30 (30, 32, 32, 34, 34) sts. and take off M/c. Push Ns. on Lt. to E pos. Dec. 1 st. on neck edge ev. alt. R. 10 (11, 11, 12, 12, 13) times to 36 (40, 44, 50, 52, 54) Rs. C.O.R. 000.

**Step 6.** K. shoulder as for back. Return Lt. sts. to M/c. and repeat neck decs. and shoulder shapings as before reversing shapings. C/O.

### SLEEVES

In C. Wl. cast on 69 (73, 77, 81, 85, 89) sts. as 1 x 1 rib. T7/6. K. 4 Rs.

**Step 1.** Tub. T8/7. K. 2 Rs. rib. C.O.R. 002.

**Step 2.** Change to M. Wl. Inc. 1 st. on each edge ev. 7 Rs. 20 (18, 16, 10, 8, 2) times. Then ev. 6 Rs. 0 (3, 6, 13, 16, 23) times. K. to 144 (148, 152, 152, 156, 156) Rs.

**Step 3.** C/O 5 (6, 7, 8, 9, 10) sts. at beg. next 2 Rs. C.O.R. 000.

**Step 4.** Dec. 1 st. on each edge ev. alt. R. 21 times. To 42 Rs. C.O.R. 000.

**Step 5.** \* H.C.L.'s II \* Push 9 (6, 5, 4, 4, 4) Ns. to E pos. at opp. end to carr. on next 2 (2, 6, 6, 6, 2) Rs. Then 8 (6, 4, 4, 3, 3) Ns. to E pos. on next 2 (4, 2, 4, 6, 12) Rs. Return Ns. on Lt. to C pos. K. 1. H.C.L. I. K. 1. C/O. Repeat.

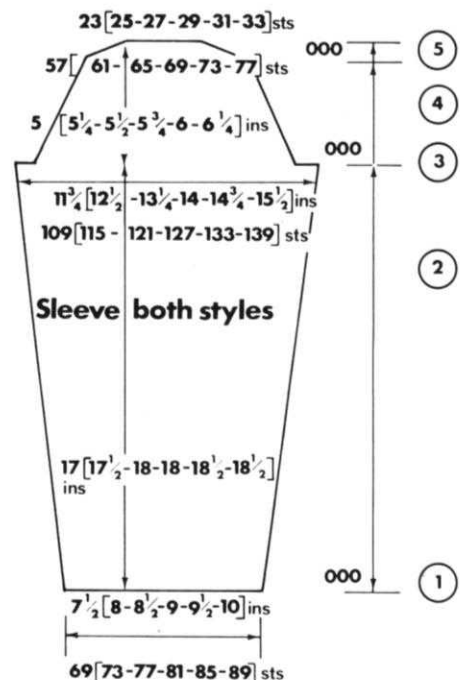

### TO MAKE UP

Press bodice pieces only. Join shoulders. Sew tops of sleeves into armholes. Press seams. Join side and sleeve seams.

### CREW NECKBAND

\* In C. Wl. Cast on 141 (145, 149, 153, 157, 161) sts. as 1 x 1 rib. T7/6. K. 4 Rs. Tub. T8/7. K. 2 Rs. Change to M. Wl. \* K. 9 Rs. Trans. Ns. to M.B. With Rt. side of work facing M/c., place Lt. side neck to 30 (31, 31, 32, 32, 33) sts. Front Neck to 30 (30, 32, 32, 34, 34) sts. C/O up to this point. Place side neck to 31 (32, 32, 33, 33, 34) sts. and back neck to rem. Ns. C/O to end.

### POLO NECKBAND

As for crew from \* to \*. K. 50 Rs. rib. Trans. Ns. to M.B. Cast off as for crew. Join band seam. Press all seams.

# lacy jumper and matching hat



## Materials

**Bodice pieces** 4 balls of Mademoiselle Pingouin. 3 balls of Twilleys Goldfingering.

**Sleeves** 3 balls of Coton du Pingouin.  $\frac{1}{4}$  in. elastic. Cone of

Kleintex invisible thread, 150 Den. Natural.

**Hat** Small ball each of Mademoiselle Pingouin and Goldfingering. 7 sequins.

## Measurements

To fit 32 (34, 36) ins. bust.

## Tensions

6 sts. and  $9\frac{1}{2}$  Rs. to 1 in. on T8 over st.st. Y.F. \*

6 sts. and  $9\frac{1}{2}$  Rs. to 1 in. on T8 over bodice jacq. Main Y.F. \* Jacq. Y.F.  $\frac{1}{2}$ .

8 sts. and 9 Rs. to 1 in. on T8 over lace jacq. Main Y.F. \*. Jacq. Y.F.  $\frac{1}{2}$ .



## Abbreviations

Y.F., Yarn Feeder; G.F., Goldfingering, C.P., Coton du Pingouin; M.P., Mademoiselle Pingouin.

**Sleeve Lacy Jacquard** Jacquard No. 84 of pattern book.

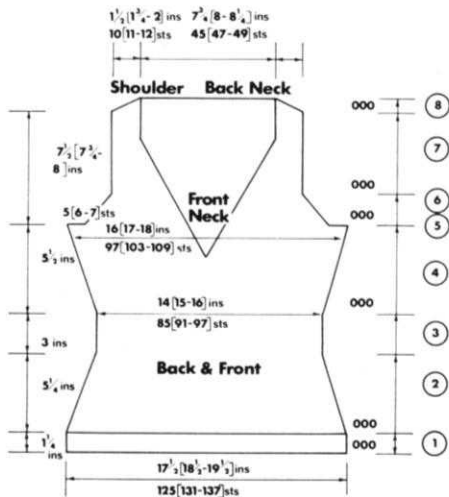

## BACK

**Step 1.** In G.F. C.O.B.H. 125 (131, 137) sts. (extra st. on Lt.). T6. K. 14 Rs. T8. K. 1. T6. K. 14 Rs. M.D.E. Set M/c. for jacq. T8. K. 1. C.O.R. 000.

**Step 2.** K. 1. repeat of patt. **At the same time** Dec. 1 st. on each edge ev. 3 Rs. 10 times. Then ev. 2 Rs. 10 times. To 50 Rs. C.O.R. 000.

**Step 3.** K. 28 Rs. straight in st.st. C.O.R. 000.

**Step 4.** Inc. 1 st. on each edge at 000. Then ev. 10 Rs. 5 times. K. to 52 Rs.

**Step 5.** C/O 5 (6, 7) sts. at beg. next 2 Rs. C.O.R. 000.

**Step 6.** Dec. 1 st. on each edge ev. R. 4 times. Then ev. alt. R. 7 times. To 18 Rs. C.O.R. 000.

**Step 7.** K. 56 (58, 60) Rs. straight. C.O.R. 000.

**Step 8.** H.P. \* Push 3 Ns. to E pos. at opp. end to carr. on next 6 Rs. Then 1 (2, 3) Ns. to E pos. on next 2 Rs. Return Ns. on Lt. to C pos. K. 1. Return Ns. on Rt. to C pos. K. 1. C/O shoulders. Thread-up back neck sts. and take off M/c.

## FRONT

As for back to step 4.

**Step 4.** As for back to 38 Rs. Dec. centre st. to Rt. Thread-up Ns. on Lt. and take off M/c. On Rt. neck dec. 1 st. ev. 3 Rs. 12 (18, 24) times. Then ev. 4 Rs. 9 (5, 1) times. **At the same time** work armhole as for back.

**Step 8.** K. 1. C.O.L. H.P. \* Push 3 Ns. to E pos. on Rt. edge ev. alt. R. 3 times. Then 1 (2, 3) Ns. to E pos. once. Return Ns. to C pos. K. 1. C/O. Return Lt. Ns. to M/c. Work as for Rt. reversing **all** shapings.

• = M.wl  
x = Contrast wl  
x = Punched Hole

## BODICE JACQUARD

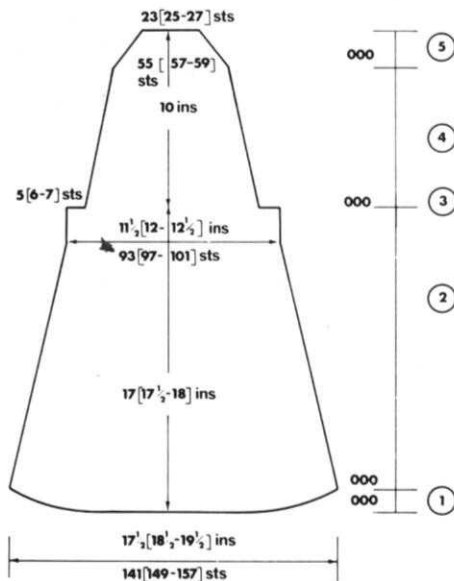
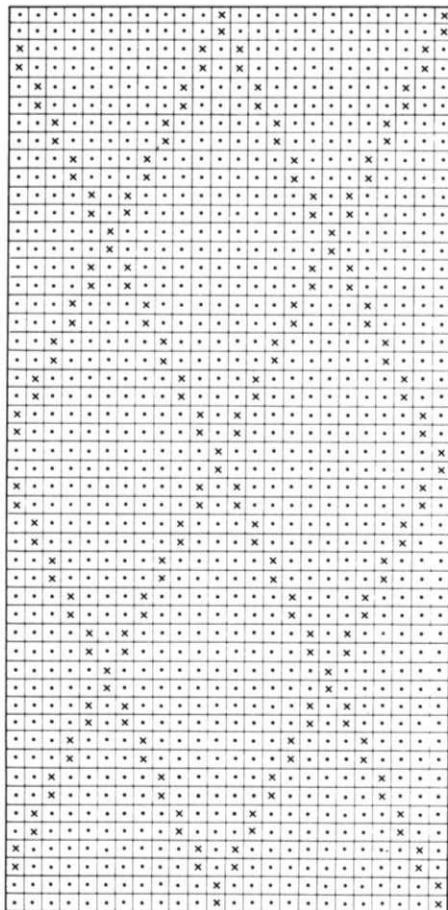

## SLEEVES

With W. Wl. Cast onto 141 (149, 157) Ns. K. a few Rs. C.O.L. Change to C.P. Set M/c. for jacq. T8. K. 1. C.O.R. 000.

**Step 1.** Start jacq. (with nylon thread in main feeder, C.P. in jacq. feeder). H.P. \* Push 36 Ns. to E pos. at opp. end to carr. on next 2 Rs. Return 6 Ns. to C pos. at opp. end to carr. on next 12 Rs. C.O.R. 000.

**Step 2.** Dec. 1 st. on each edge ev. 5 Rs. 24 (26, 28) times. K. to 140 (144, 148) Rs.

**Step 3.** C/O 5 (6, 7) sts. at beg. next 2 Rs. C.O.R. 000.

**Step 4.** Dec. 1 st. on each edge ev. 5 Rs. 14 times. K. to 72 Rs. C.O.R. 000.

**Step 5.** H.P. \* Push 2 Ns. to E pos. at opp. end to carr. on next 16 Rs. Return Ns. on Lt. to C pos. K. 1. Return Ns. on Rt. to C pos. K. 1. C/O. Repeat.

## TO MAKE UP

Press all pieces. Join shoulders.

## NECKBAND

In G.F. C.O.B.H. 181 (187, 193) sts. T6. Dec. 1 st. on each edge ev. alt. R. 7 times. (14 Rs.) T8. K. 1. T6. Inc. 1 st. on each edge ev. alt. R. 7 times. (29 Rs.) M.D.E. With Rt. side of work facing M/c. place side neck to 68 (70, 72) Ns. Back Neck to 45 (47, 49) Ns. C/O up to this point. Place side neck to rem. Ns. C/O in M.P.

## SLEEVE BANDS

In G.F. C.O.B.H. 60 sts. T6. K. 6. T8. K. 1. T6. K. 6. M.D.E. With Rt. side of work facing M/c., place first C.P. sts. onto band, doubling-up on sts. Remove W. Wl. C/O to end in M.P. Sew tops of sleeves into armholes. Press seams. Join side and sleeve seams, up to sleeve bands. Thread 1/4 in. elastic into bands. Close bands. Press all seams and bands.

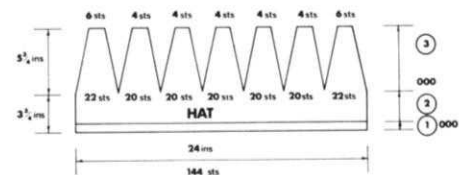

## HAT

In G.F. C.O.B.H. 144 sts. T6. K. 6. T8. K. 1. T6. K. 6. M.D.E.

**Step 1.** Set M/c. for jacq. T8. K. 1. C.O.R. 000.

**Step 2.** K. 26 Rs. of jacq. C.O.R. 000.

**Step 3.** In st.st. to end. H.P. Leaving 22 Ns. in B pos. on Rt. edge, push all other Ns. to E pos. \* Dec. 1 st. on each edge at 000. Then dec. 1 st. on each edge ev. 7 Rs. 7 times. K. to 50 Rs. Thread-up rem. sts. and take off M/c. \* Push next 20 sts. on Rt. edge to C pos. Repeat from \* to \*. Cont. in this way to end. Press hat. Join points and back seam. Draw-up thread-up sts. tightly and secure thread. Press all seams. Sew on sequins.

# ribbed cardigan and midi-skirt

Lady's 3 x 3 ribbed cardigan featuring 1 x 1 ribbed pockets and turn-back cuffs. Worn with classic skirt in 3 x 3 rib.

## Materials

**Cardigan** 15 (16, 16, 17) balls of M. Wl. 1 ball of Contrast Wl. Lister Lavenda or Lee Target Motoravia 4 ply wool. 5 buttons.

**Skirt** 15 (16, 17, 18) balls of M. Wl. 8 in. zip. 1 in. elastic by desired length.

## Measurements

To fit 32 (34, 36, 38) ins. bust.

Sleeve seam 17 (17½, 17½, 18) ins.

Length from shoulder 23½ (23½, 23¾, 24) ins.

## Skirt

To fit hip 34 (36, 38, 40).

Length from waist 24½ (25, 25½, 26) ins.

## Tensions

7½ sts. and 12½ Rs. to 1 in. on T4/4 over 3 x 3 rib.

1 x 1 rib on T3/3.

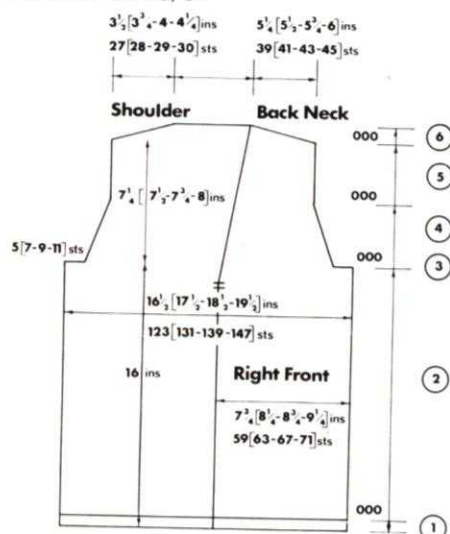

## CARDIGAN

### BACK

**Step 1.** In M. Wl. Cast on 123 (131, 139, 147) sts. as 1 x 1 rib. \* TO/O. K. 4 Rs. Tub. T3/3. K. 6 Rs. rib. Trans. to 3 x 3 rib. C.O.R. 000. \*

**Step 2.** T4/4. K. 194 Rs. straight.

**Step 3.** C/O 5 (7, 9, 11) sts. at beg. next 2 Rs. C.O.R. 000.

**Step 4.** Dec. 1 st. on each edge ev. 4 Rs. 10 times to 40 Rs. C.O.R. 000.

**Step 5.** K. 48 (52, 56, 60) Rs. to shoulder. C.O.R. 000.

**Step 6.** H.P. \* Push 5 Ns. to E pos. at opp. end to carr. on next 6 (8, 10, 12) Rs. Then 4 Ns. to E pos. on next 6 (4, 2, 0) Rs. Return Ns. on Lt. to C pos. K. 1. Return Ns. on Rt. to C pos. K. 1. C/O.

### RIGHT FRONT

**Step 1.** In M. Wl. Cast on 59 (63, 67, 71) sts. as 1 x 1 rib. K. as \* to \* of back.

**Step 2.** As for back. After 182 Rs. start front neck. Mark Lt. edge st. with contrast coloured Wl. Dec. this st. Then dec. 1 st. on Lt. edge ev. 6 Rs. 10 (13, 16, 19) times, then ev. 7 Rs. 6 (4, 2, 0) times. **At the same time** After 19 Rs.

**Step 3.** C/O 5 (7, 9, 11) sts. K. 2 Rs. C.O.R. 000.

**Step 4.** Dec. as for back.

**Step 5.** As for back.

**Step 6.** K. 1. H.P. \* Push 5 Ns. to E pos. on Rt. edge ev. alt. R. 3 (4, 5, 6) times. Then 4 Ns. to E pos. 3 (2, 1, 0) times. Return Ns. to C pos. K. 1. C/O.

### LEFT FRONT

K. as for right, reversing **all** shapings.

### SLEEVES

**Step 1.** In contrast Wl. Cast on 59 (59, 63, 63) sts. as 1 x 1 rib. TO/O. K. 4 Rs. Tub. T3/3. K. 4 Rs. rib. Change to M. Wl. K. 76 Rs. Trans. Ns. to 3 x 3 rib. C.O.R. 000.

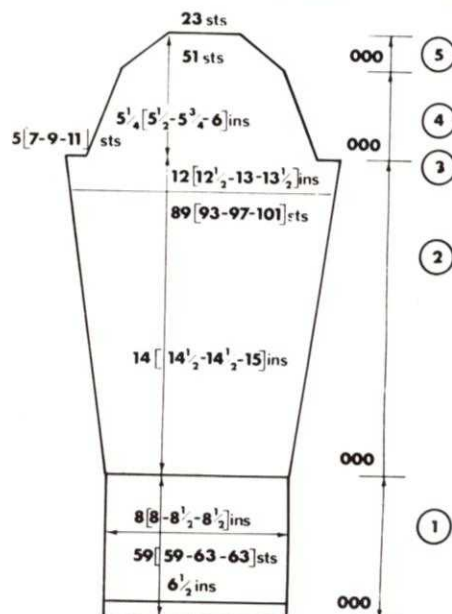



**Step 2.** T4/4. Inc. 1 st. on each edge ev. 11 (10, 10, 9) Rs. 15 (17, 17, 19) times. K. to 174 (180, 180, 186) Rs.

**Step 3.** C/O 5 (7, 9, 11) sts. at beg. next 2 Rs. C.O.R. 000.

**Step 4.** Dec. 1 st. on each edge ev. 4 Rs. 14 times to 56 Rs. C.O.R. 000.

**Step 5.** H.P. \* Push 4 (3, 2, 2) Ns. to E pos. at opp. end to carr. on next 4 (4, 12, 8) Rs. Then 3 (2, 1, 1) Ns. to E pos. on next 4 (8, 4, 12) Rs. Return Ns. on Lt. to C pos. K. 1. Return Ns. on Rt. to C pos. K. 1. C/O.

### TO MAKE UP

Press all pieces.

### HIP POCKETS

In contrast Wl. Cast on 39 sts. as 1 x 1 rib. \* T0/O. K. 4 Rs. Tub. T3/3. K. 4 Rs. rib. \* In M. Wl. K. 63 Rs. rib. Trans. Ns. to M.B. C/O. Repeat.

### BREAST POCKET

In contrast Wl. Cast on 27 sts. As \* to \* above. In M. Wl. K. 43 Rs. Trans. Ns. C/O. Press pockets. Pin hip pockets onto fronts, level with bottom of hem and  $1\frac{1}{2}$  ins. across from front edge. Sl.st. in place. Pin breast pocket onto right front, with the top level with under arm and 2 ins. across from front edge. Sl.st. breast pocket in place. Join shoulders. Sew tops of sleeves into armholes. Press seams. Join side seams and sleeve seams up to centre of cuff. Turn back cuff and sl.st.

### FRONT BAND

In M. Wl. Cast on 20 sts. as 'All-needle rib'. (1 st. on M.B. Last st. on rib bed.) T0/O. K. 4 Rs. Tub. T2/2. K. 24 Rs. rib. \* H.P. \* Push 10 Ns. to E pos. on Lt. edge. K. 9 Rs. C.O.L. Push all Ns. to E pos. Move carr. to Rt. Return 10 Ns. on Lt. to C pos. Break-off Y. and thread between sets of Ns. K. 9 Rs. C.O.L. Return Ns. on Rt. to C pos. K. 23 Rs. \* Repeat from \* to \* making 5 holes in all. Cont. until band is long enough to fit up both fronts and across back neck, stretching slightly and C/O. Pin band to Rt. front with centre of top buttonhole level with marked st. Sl.st. in place. Press all seams and band. Turn back cuffs and secure in place. Sew on buttons to correspond with holes.

### SKIRT

#### BACK AND FRONT

**Step 1.** In M. Wl. Cast on 173 (181, 189, 197) sts. as 1 x 1 rib. T0/O. K. 4 Rs. Tub. T3/3. K. 6 Rs. rib. Trans. Ns. to 3 x 3 rib. C.O.R. 000.

**Step 2.** T4/4. Dec. 1 st. on each edge ev. 11 (11, 11, 12) Rs. 19 times. K.

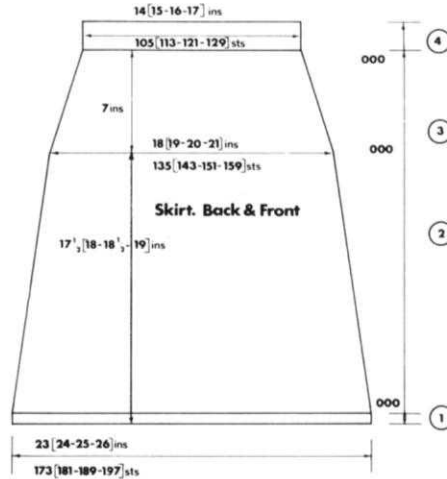

to 212 (218, 224, 230) Rs. C.O.R. 000.

**Step 3.** Dec. 1 st. on each edge at 000. Then ev. 6 Rs. 14 times. K. to 88 Rs. C.O.R. 000.

**Step 4.** Trans. Ns. to 1 x 1 rib. T3/3. K. 26 Rs. straight. Trans. Ns. to M.B. C/O. Repeat.

### TO MAKE UP

Press both pieces. (Do not remove from pressing-board until completely dry.) Join seams, leaving 7 ins. opening on Lt. side. Fold 1 x 1 rib at top in half and sl.st. in place on wrong side. Press all seams and band. Insert elastic into waistband and secure at each end. Crochet down zip opening. Insert zip. Press.



# man's cardigan and vest

Man's cardigan featuring vertical diamond stripe, worn with vest in diamond jacquard.

## Materials

**Cardigan** 9 (9, 10, 10, 11) balls of colour A. 5 (5, 5, 6, 6) balls of colour B. 2 balls of colour C. Debbie Anne 4 ply wool. 6 buttons.

**Vest Top** 4 balls of colour A. 5 (5, 5, 6, 6) balls of B. 2 balls of C. Debbie Anne 4 ply wool.

## Measurements

To fit 34 (36, 38, 40, 42) ins. chest.

Sleeve seam 17½ (18, 18, 18½, 18½) ins.

Length from back neck 24 (24¼, 24½, 24¾, 25) ins.

## Tensions

7 sts. and 9½ Rs. to 1 in. on T6¾ over st.st.

7 sts. and 9 Rs. to 1 in. on T7¾ over vest top jacq.

## Note

When knitting jacq. (especially on cardigan), always push each N. at edge of work to C pos.

## JACQUARD FOR CARDIGAN

This Punch-Card is for LEFT FRONT  
For RIGHT FRONT use upside down

☒ = COLOUR A

• = COLOUR B

■ = COLOUR C

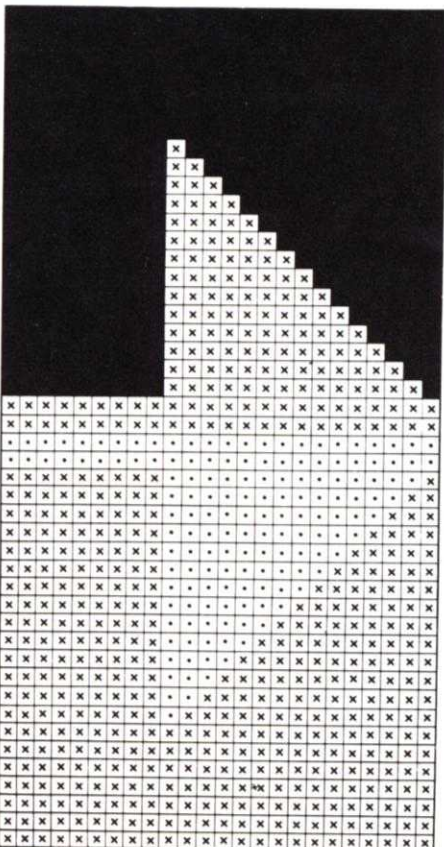

## CARDIGAN BACK

**Step 1. Ribbers** In colour A. Cast on 123 (131, 139, 147, 155) sts. as 1 x 1 rib. \* T0/O. K. 4 Rs. Tub. T3/3. K. 28 Rs. rib. Change to colour B. K. 4 Rs. Trans. Ns. to M.B. \* C.O.R. 000.

**Single bed M/cs.** With colour A. C.O.B.H. 123 (131, 139, 147, 155) sts. T6. K. 34 Rs. T8. K. 1. T6. K. 30 Rs. Change to colour B. K. 4 Rs. M.D.E. T6¾. In colour A. K. 1. C.O.R. 000.

**Step 2.** K. 110 Rs. straight.

**Step 3.** C/O 5 (6, 7, 8, 9) sts. at beg. next 2 Rs. C.O.R. 000.

**Step 4.** Dec. 1 st. on each edge ev. 5 Rs. 8 times to 40 Rs. C.O.R. 000.

**Step 5.** K. 42 (44, 46, 48, 50) Rs. straight. C.O.R. 000.

**Step 6.** H.P. \* Push 5 (6, 6, 7, 7) Ns. to E pos. at opp. end to carr. on next 8 Rs. Then 6 (4, 6, 4, 6) Ns. to E pos. on next 2 Rs. Return Ns. on Lt. to C pos. K. 1. Return Ns. on Rt. to C pos. K. 1. Thread-up back neck sts. C/O shoulders.



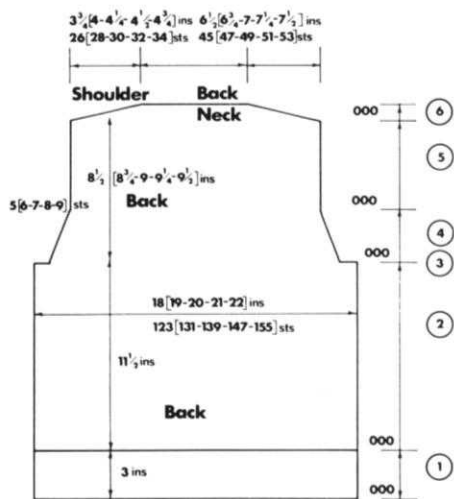

### RIGHT FRONT

Starting the 5th N. to Lt. of centre, rest to Rt. In colour C, C.O.B.H. 81 sts. C.O.R. 000.

**Step 1.** On Lt. edge cast on 6 sts. ev. alt. R. 10 times. Then cast on 5 sts. ev. alt. R. once. Then cast on 0 (2, 4, 4, 4) sts. ev. alt. R. once. Then 0 (0, 0, 2, 4) Ns. ev. alt. R. once. K. to 23 (24, 25, 26, 27) Rs. 146 (148, 150, 152, 154) sts.

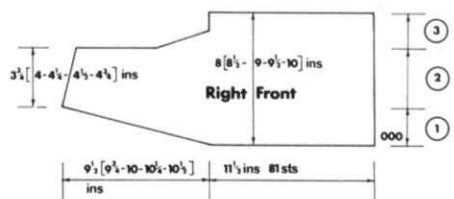

**At the same time** After 19 (21, 21, 23, 23) Rs. set M/c. for jacq. (using punch-card upside down) K. 1. Start jacq. (K. background colours as for graph, but K. 1st triangle in colour B and second triangle in colour C.) K. 32 Rs. of jacq. Then cont. in st.st. to end in colour A.

**Step 2.** Dec. 1 st. on Lt. edge ev. 4 (5, 5, 6, 6) Rs. 7 times. K. to 34 (36, 40, 42, 46) Rs. On Lt. edge C/O 34 (36, 38, 40, 42) sts.

**Step 3.** On Lt. edge C/O 4 sts. ev. alt. R. 6 times to 81 sts. K. 7 (8, 9, 10, 11) Rs. straight. (76 (80, 86, 90, 96) Rs. in all.) C/O to end.

### LEFT FRONT

Starting the 5th N. to Rt. of centre, rest to Lt. Cast on in colour A and K. as for Rt. front, reversing all shapings. Use punch-card right way up with colour sequences as for graph.

### FRONT RIBS

**Ribbers** In colour A. Cast on 55 (59, 63, 67, 71) sts. as 1 x 1 rib, K. as for back \* to \*.

**Single bed M/cs.** In W. Wl. Cast onto 55 (59, 63, 67, 71) sts. K. a few Rs. Change to colour B. T6. K. 4 Rs. Change to colour A. K. 30 Rs. T8. K. 1. T6. K. 34 Rs. M.D.E. Unravel W. Wl. With right side of work facing M/c., place front edge evenly onto Ns. C/O in same colour as bodice knitting. Repeat.

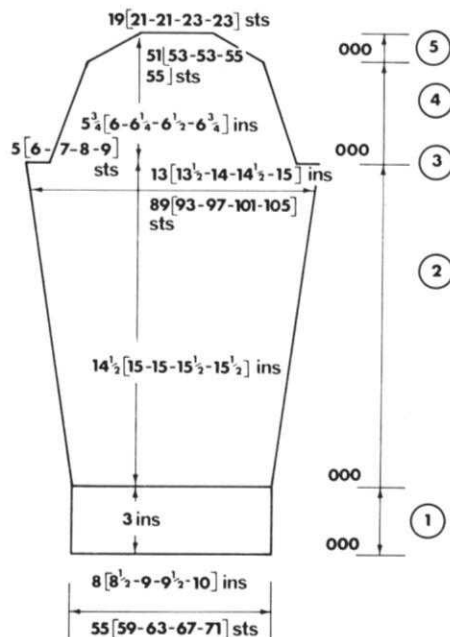

### SLEEVES

**Step 1. Ribbers** In colour A. Cast on 55 (59, 63, 67, 71) sts. as 1 x 1 rib. T0/O. K. 4 Rs. Tub. T3/3. K. 32 Rs. rib. Trans. Ns. to M.B. C.O.R. 000.

**Single bed M/cs.** With colour A. C.O.B.H. 55 (59, 63, 67, 71) sts. T6. K. 34 Rs. T8. K. 1. T6. K. 34 Rs. M.D.E. Change to colour B. T6 2/3. K. 1. C.O.R. 000.

**Step 2.** Inc. 1 st. on each edge ev. 8 Rs. 17 times. K. to 138 (142, 142, 146, 146) Rs.

**Step 3.** C/O 5 (6, 7, 8, 9) sts. at beg. next 2 Rs. C.O.R. 000.

**Step 4.** Dec. 1 st. on each edge ev. 3 Rs. 12 (10, 12, 10, 12) times. Then ev. 4 Rs. 2 (4, 3, 5, 4) times. To 44 (46, 48, 50, 52) Rs. C.O.R. 000.

**Step 5.** H.P. \* Push 3 Ns. to E pos. at opp. end to carr. on next 8 Rs. Then 2 Ns. to E pos. on next 4 Rs. Return Ns. on Lt. to C pos. K. 1. Return Ns. on Rt. to C pos. K. 1. C/O.

### TO MAKE UP

Press all pieces. Join shoulders. Sew tops of sleeves into armholes. Press seams. Join side and sleeve seams.

### FRONT BANDS

With W. Wl. Cast onto 184 (187, 190, 193, 196) sts. K. a few Rs. Change to colour B. T5. K. 6. Change to colour A. K. 22. T7. K. 1. T5. K. 28 Rs. M.D.E. With right side of Rt. front neck to next 56 (58, 60, 62, 64) Ns. Front to 81 Ns. and rib edge to 24 Ns. C/O with same colour as bodice knitting.

### BUTTONHOLE BAND

After knitting 11 Rs. in colour A, make holes. \* Starting the 3rd st. in from Rt. edge, using W. Wl., by hand K. 7 sts. Leave space of 15 Ns. between holes and make 6 holes in all. \* K. 11 Rs. T7. K. 1. T5. K. 11 Rs. Repeat holes. K. 17 Rs. M.D.E. C/O as before, reversing process. Join bands at back neck. Finish off buttonholes. Press all seams and bands. Sew on buttons.

[x] = Colour A    [x] & [ ] = Punched Holes  
 [•] = Colour B  
 [■] = Colour C  
 [ ] = Background

JACQUARD FOR VEST TOP

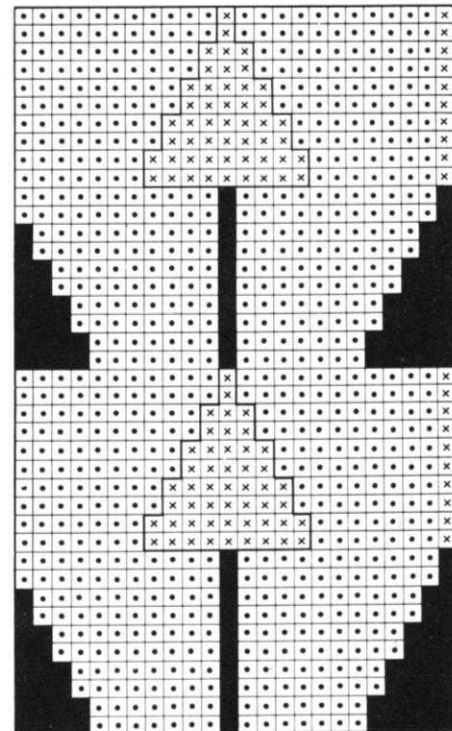

### VEST TOP BACK

**Step 1. Ribbers** In colour A. Cast on 121 (129, 137, 145, 153) sts. as 1 x 1 rib. T0/O. K. 4 Rs. Tub. T3/3. K. 21 Rs. Trans. Ns. to M.B.

**Single bed M/cs.** With W. Wl. Cast onto 121 (129, 137, 145, 153) sts. K. a few Rs. Change to colour A. T6.

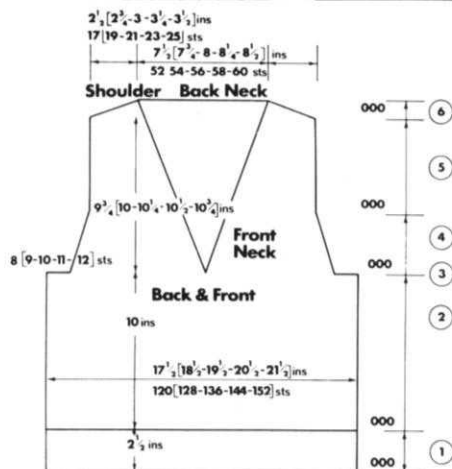
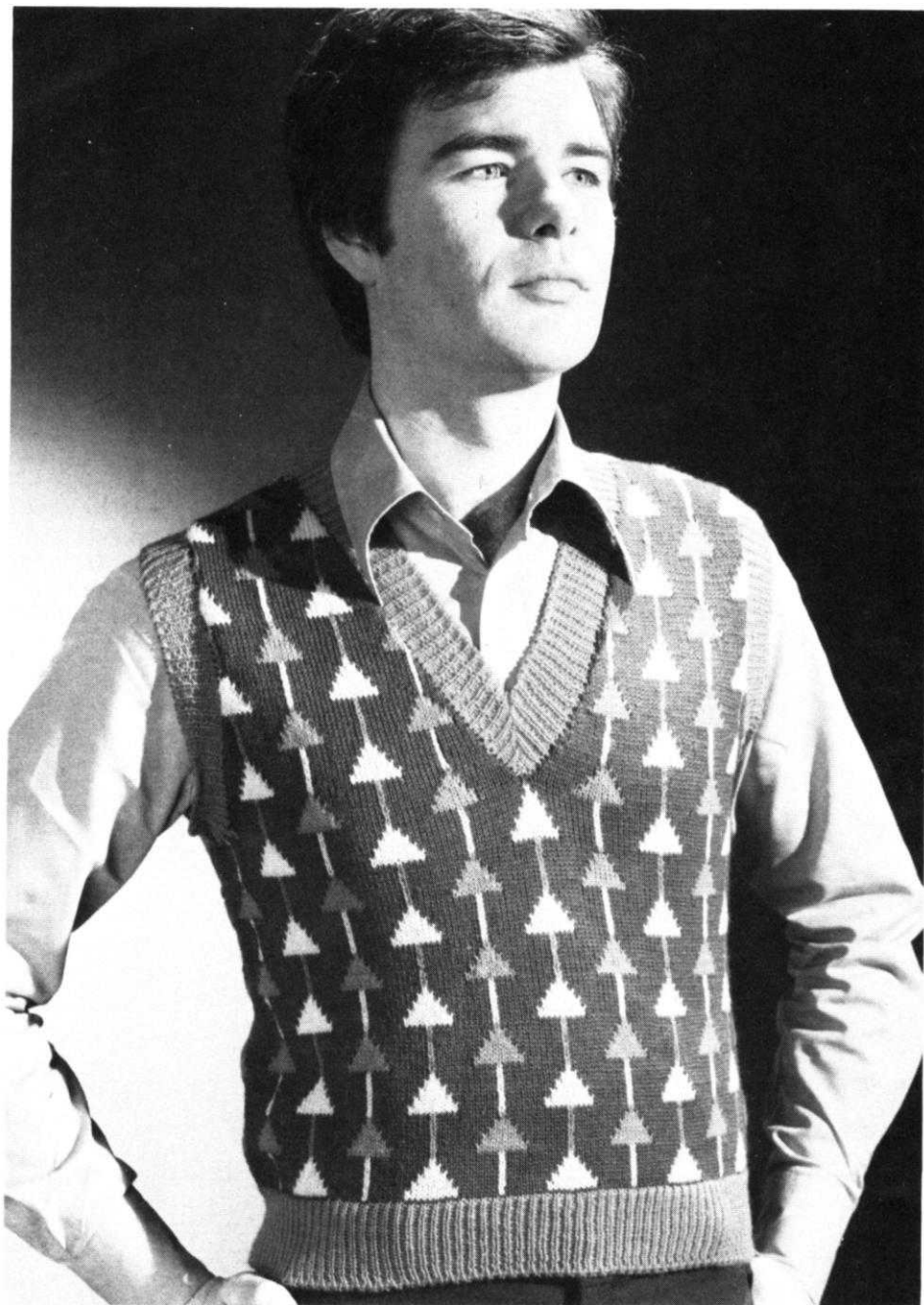

K. 23 Rs. T8. K. 1. T6. K. 23 Rs. M.D.E. Remove W. WI. T6  $\frac{2}{3}$ . Set M/c. for jacq. K. 1. C.O.R. Dec. 1 st. 000.

**Step 2.** T7  $\frac{2}{3}$ . Start patt. K. 90 Rs.

**Step 3.** C/O 8 (9, 10, 11, 12) sts. at beg. next 2 Rs. C.O.R. 000.

**Step 4.** Dec. 1 st. on each edge ev. 4 Rs. 9 times to 36 Rs. C.O.R. 000.

**Step 5.** K. 52 (54, 56, 58, 60) Rs. to shoulder. C.O.R. 000.

**Step 6.** H.P. \* Push 4 (5, 5, 6, 6) Ns. to E pos. at opp. end to carr. on next 6 Rs. Then 5 (4, 6, 5, 7) Ns. to E pos. on next 2 Rs. Return Ns. on Lt. to C pos. K. 1. Return Ns. on Rt. to C pos. K. 1. Thread-up back neck sts. and take off. C/O shoulders.

## FRONT

As for back to step 4.

**Step 4.** H.P. Push Ns. to Lt. of centre to E pos. At the same time as working armhole as for back, on front neck dec. 1 st. at 000 then ev. 4 Rs. 15 times. Then ev. 3 Rs. 10 (11, 12, 13, 14) times.

**Step 6.** K. 1. C.O.L. H.P. \* Push 4 (5, 5, 6, 6) Ns. to E pos. on Rt. edge ev. alt. R. 3 times. Then 5 (4, 6, 5, 7) Ns. to E pos. once. Return Ns. on Rt. to C pos. K. 1. C/O. Return Ns. on Lt. to B pos. and set for jacq. Work front neck and armhole as before, reversing all shapings.

**Step 6.** C.O.R. H.P. \* Push 4 (5, 5, 6, 6) Ns. to E pos. on Lt. edge ev. alt. R. 3 times. Then 5 (4, 6, 5, 7) Ns. to E pos. once. Return Ns. to C pos. K. 1. C/O.

## TO MAKE UP

Press. Join shoulders.

## ARMBANDS

**Ribbers** In colour A. Cast on 119 (123, 127, 131, 135) sts. as 1 x 1 rib. T0/O. K. 4 Rs. Tub. T3/3. Inc. 1 st. on each edge ev. alt. R. 7 times. Trans. Ns. to M.B.

**Single bed M/cs.** With W. WI. Cast onto 133 (137, 141, 145, 149) sts. K. a few Rs. Change to colour A. T5. Dec. 1 st. on each edge ev. alt. R. 8 times. T7. K. 1. T5. Inc. 1 st. on each edge ev. alt. R. 8 times. (17 Rs. in all.) M.D.E. Unravel W. WI. With Rt. side of work facing M/c., place armhole evenly onto Ns. and C/O in colour B.

## NECKBAND

**Ribbers** In colour A. Cast on 156 (162, 168, 174, 180) sts. as 1 x 1 rib. T0/O. K. 4 Rs. Tub. T3/3. Inc. 1 st. on each edge ev. alt. R. 9 times. Trans. Ns. to M.B.

**Single bed M/cs.** With W. WI. Cast onto 174 (180, 186, 192, 198) sts. K. a few Rs. Change to colour A. T5. Dec. 1 st. on each edge ev. alt. R. 10 times. T7. K. 1. T5. Inc. 1 st. on each edge ev. alt. R. 10 times. (21 Rs. in all.) M.D.E. Unravel W. WI. With Rt. side of work facing M/c. Place side neck to 61 (63, 65, 67, 69) Ns. Back neck to 52 (54, 56, 58, 60) Ns. C/O in colour B up to this point. Place side neck to rest of Ns. and C/O to end. Join neckband mitre. Join side seams and armband mitres. Press all seams and bands.













# PATTERNS

from Jones the knitting machine people

Here's the new style pattern service from Jones - superb collections of garments in attractive booklet form, each booklet containing a series of garments for one section of your family.

BOOK 1. ribbed garments 2. general family garments  
3. toddlers garments 4. garments for children  
5. ladies garments 6. garments for men 7. garments from 'Home Sewing and Knitting' 8. a series of simple basic patterns

BOOKLETS 1-8 25p

**AND NOW  
2 NEW BOOKLETS**

**BOOK 9**  
Classic baby garments

**BOOK 10**  
Toddlers garments

**BOOKLETS 9-10**  
30p

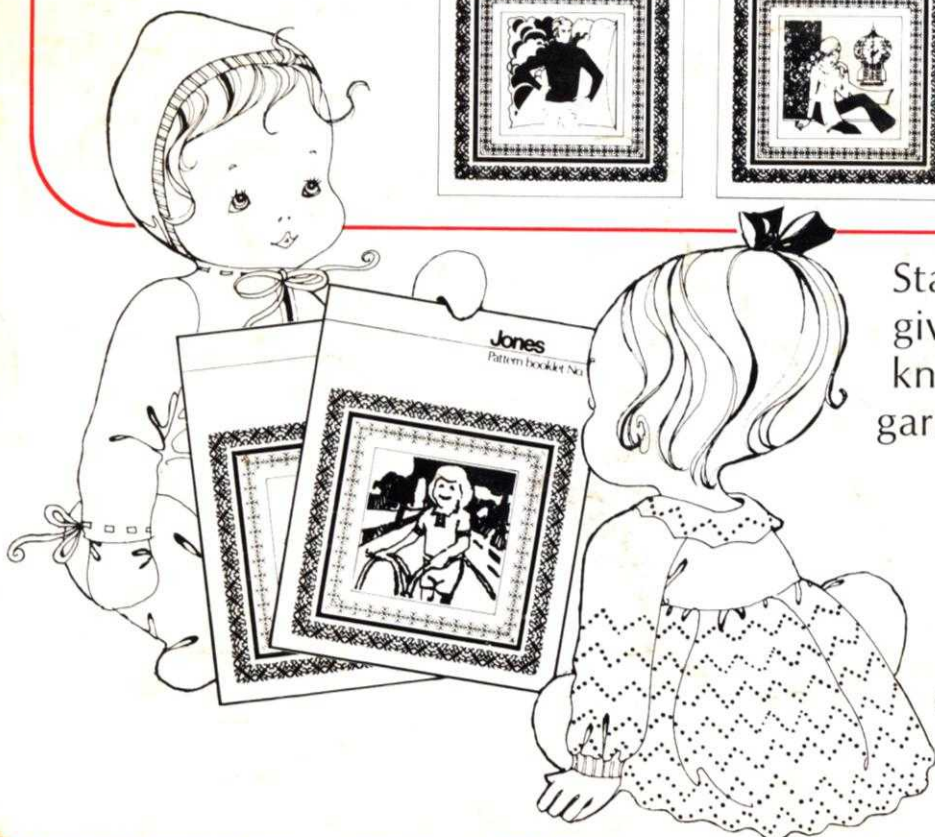
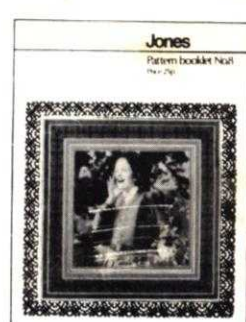
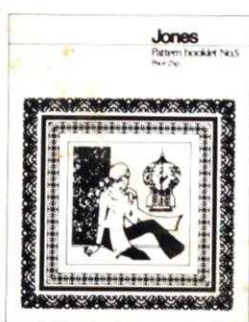
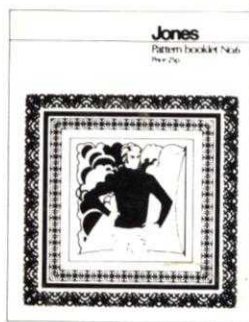
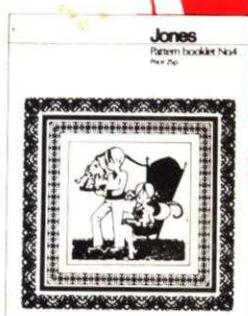
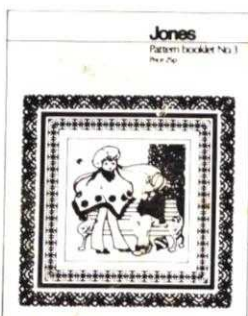

Start collecting the set now - they'll give you many hours of enjoyable knitting and a whole new range of garments for the family!

They are obtainable from your local Jones stockist or direct from  
**Pattern Book Dept.,  
Jones Sewing Machine  
Co. Ltd., Shepley Street,  
Guide Bridge, Audenshaw,  
Manchester M34 5JD.**



*all around your home*