

INSTRUCTION MANUAL FOR RIBBING ATTACHMENT

MODEL **KR-230**

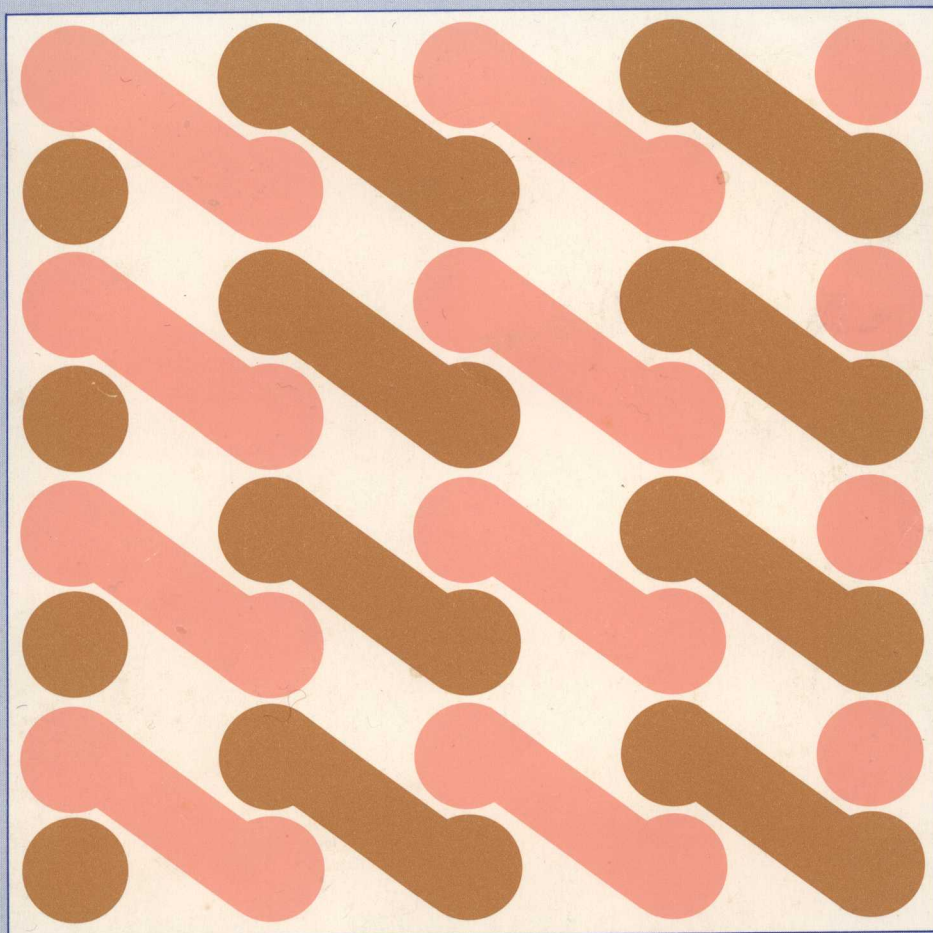

INDEX

I.	NAME OF PARTS	1
II.	ACCESSORIES	2
III.	SETTING UP YOUR RIBBER TO THE KNITTER	3
IV.	TAKING OFF THE RIBBER FROM THE MACHINE	8
V.	IMPORTANT POINTS TO REMEMBER BEFORE YOU START KNITTING	
	(1) Tension dial	9
	(2) Needle position	10
	(3) Racking grip handle	10
	(4) Bracket lever	11
	(5) Disconnecting the carriage	12
VI.	HOW TO USE THE ACCESSORIES	13
VII.	HOW TO KNIT 1 x 1 RIB	15
VIII.	HOW TO KNIT 2 x 2 RIB	21
IX.	HOW TO KNIT FULL NEEDLE RIB	24
X.	HOW TO KNIT 5 x 5 RIB	26
XI.	HOW TO KNIT CIRCULAR KNITTING	28
XII.	HOW TO KNIT ENGLISH RIB	30
XIII.	HOW TO KNIT RACKING PATTERN OF ENGLISH RIB	31
XIV.	HOW TO KNIT RACKING PATTERN (I)	32
XV.	HOW TO KNIT RACKING PATTERN (II)	34
XVI.	MAKING GARMENTS	
	(1) Increasing the stitches	35
	(2) Decreasing the stitches	36
	(3) How to shape the neck line	38
	(4) How to transfer the stitches	38
	(5) Binding off and finishing edge	40
XVII.	USEFUL HINTS	
	(1) How to pick up dropped stitch and unravelling the rows	41
	(2) If the carriage should jam and using the knitter as a single bed with the ribber attached	42
	(3) How to replace the purl needle	43
	(4) Maintenance	43

I. NAME OF PARTS

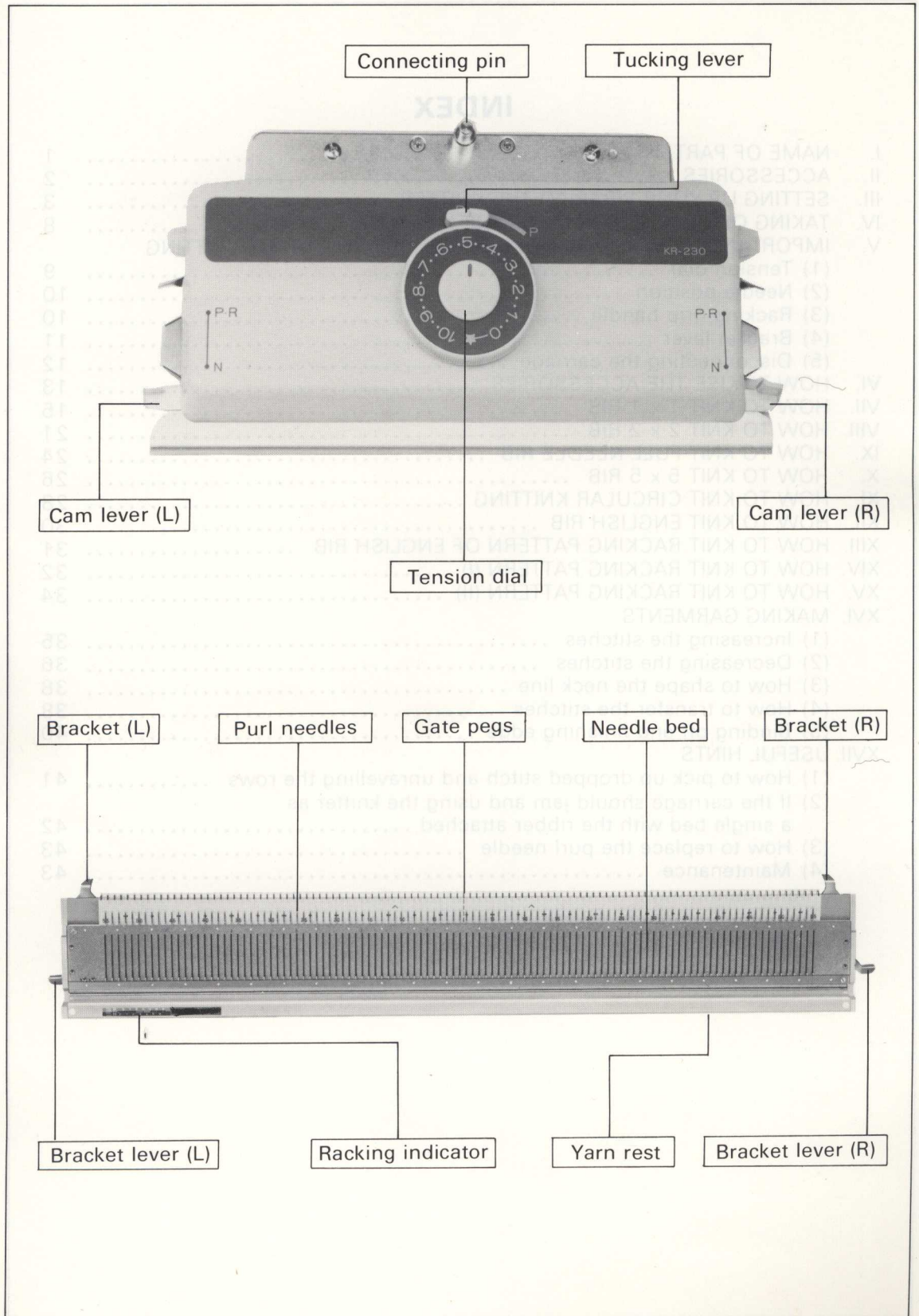

II. ACCESSORIES



Connecting arm assembly



Pressers



Table clamps

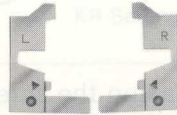
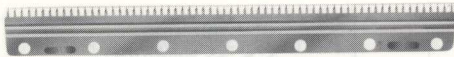

Needle stopper R & L

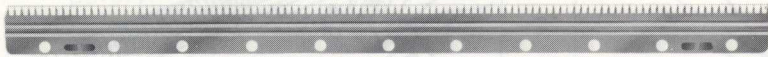

Cast-on Comb, long (110 stitches)
short (64 stitches)

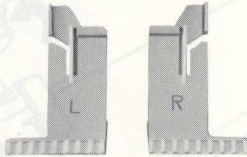

Extension rack R & L

Grip handle



Yarn tension stand

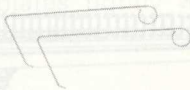

Wire-loop type weight hangers



Claw type weight hangers



Spanner



Cast-on thread



Work hook



Spare needles



Case



Transfer needle



2/1 x 2/2 needle pusher



Large weights



Small weights

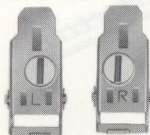

KR setting plate (R & L)



KL setting plates

III. SETTING UP YOUR RIBBER TO THE KNITTER

(1) Secure the knitter onto a flat table using the Table clamps provided as an accessory for the ribber.

1) Insert the top of the thumb screws of the table clamps into the holes on the back of the knitter.

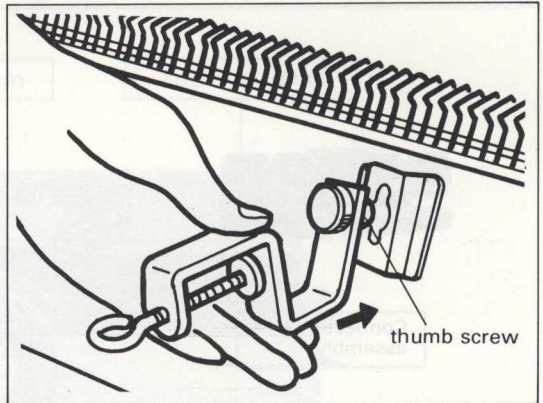

2) Fasten the screws.

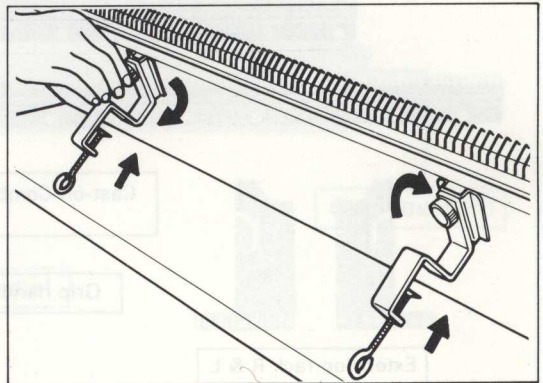

3) Secure the table clamps onto the table to tilt the knitter.

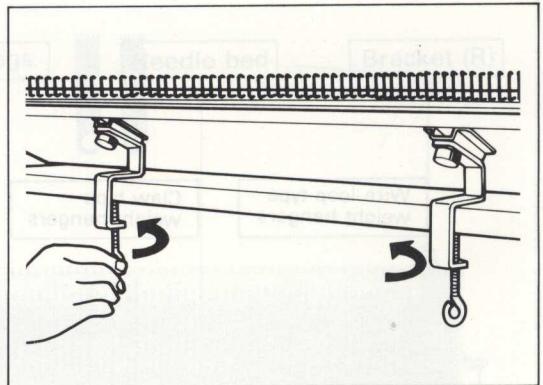

(2) Put the KR Setting plates to the knitter.

1) Remove the thumb screws from the KR Setting Plates.

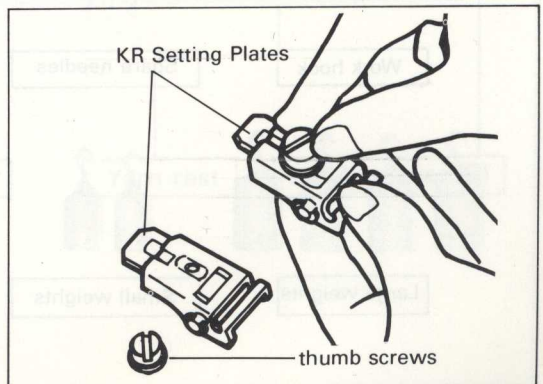

- 2) Insert them into the holes of both sides of the knitter.
(Be careful of the R and L marks on the plates. R stands for right and L stands for left.)



- 3) Screw the KR Setting Plates temporary.

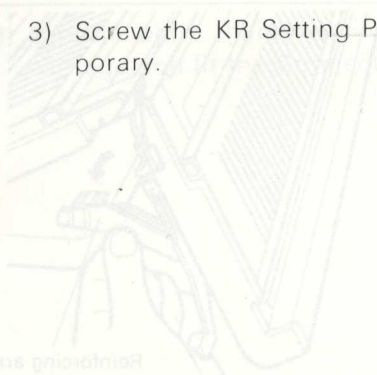

- 4) Push the Setting Plates Stopper until they touch (A) and screw the plates tightly with the accessory spanner.

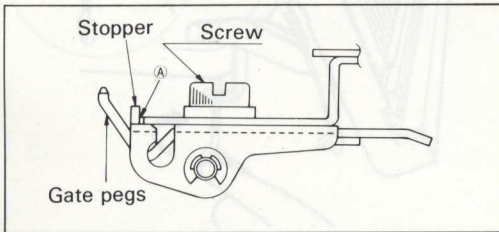

8 Cross-sectional view from right

- (3) Insert the Grip shaft into the Racking grip shaft holder, and turning the grip handle, push it in until you hear the "click".

After setting the grip handle, please check the working of the racking grip handle by turning it.

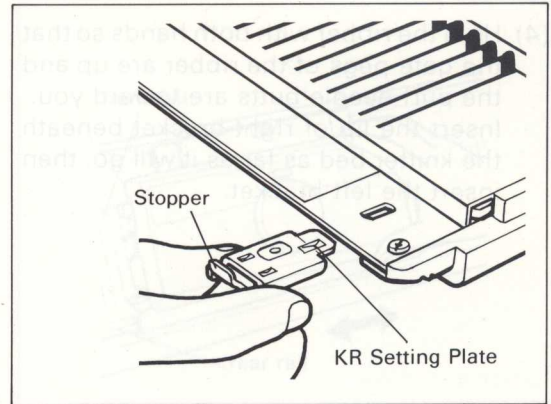

5

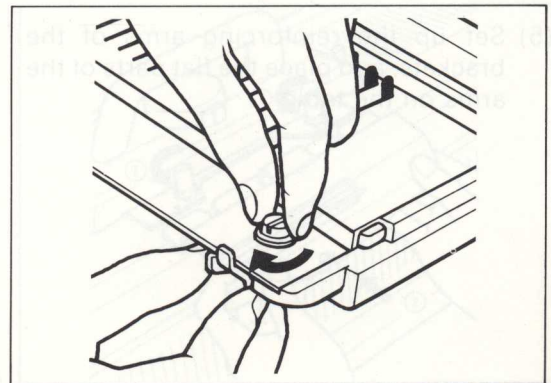

6

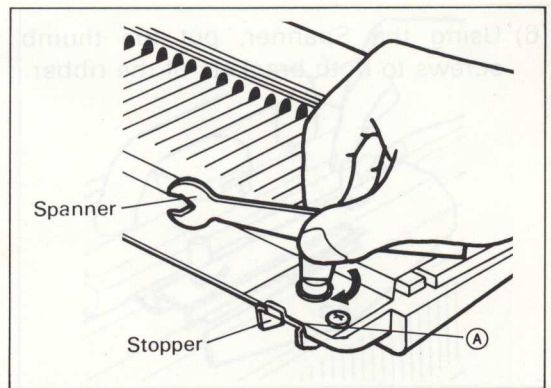

7

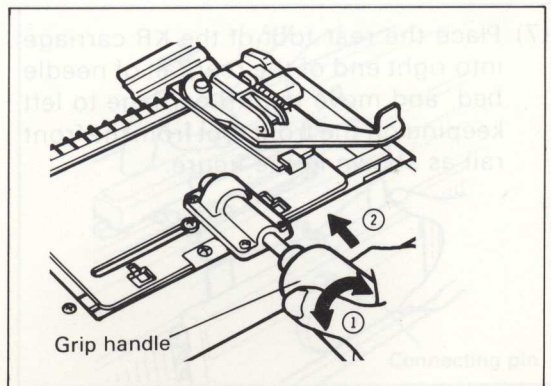

9

III. SETTING UP YOUR RIBBER TO THE KNITTER

- (4) Hold the ribber with both hands so that the gate pegs of the ribber are up and the purl needle butts are toward you. Insert the lip of right bracket beneath the knitter bed as far as it will go, then insert the left bracket.

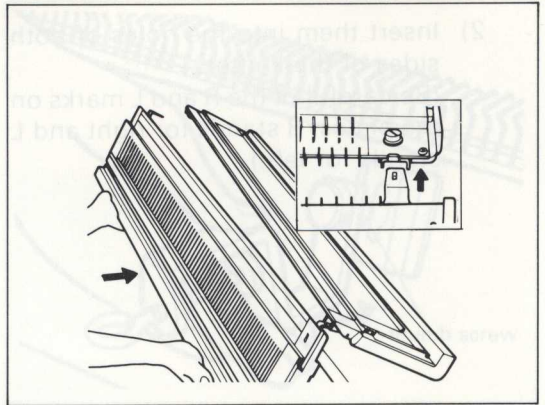

10

- (5) Set up the reinforcing arms of the brackets, and place the flat parts of the arms on the table.

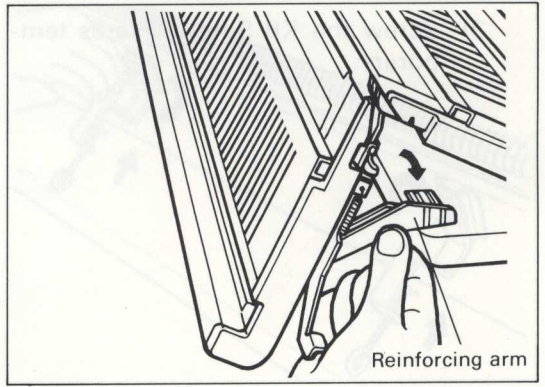

11

- (6) Using the Spanner, put the thumb screws to both brackets of the ribber.

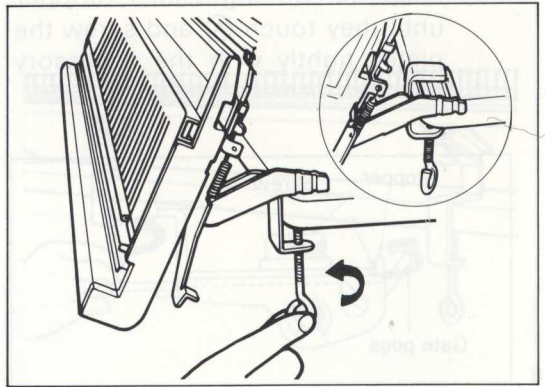

12

- (7) Place the rear foot of the KR carriage into right end of the rear rail of needle bed, and move the KR carriage to left keeping off the front foot from the front rail as shown in the figure.

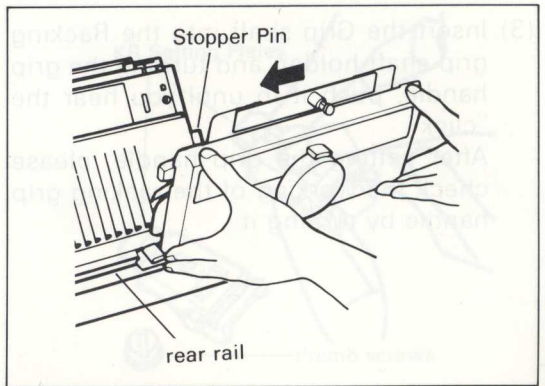

13

IV. TAKING OFF THE RIBBER FROM MACHINE

- (8) Check if front and rear foot is set to the front and rear rail of the KR needle bed correctly.
The KR carriage should move smoothly.

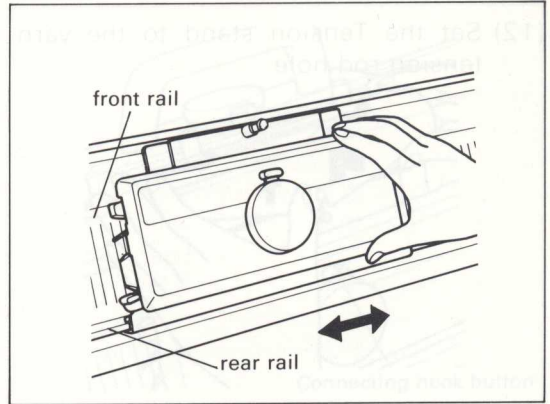

14

- (9) Loosen both thumb screws of KH carriage and fit the Connecting Arm.

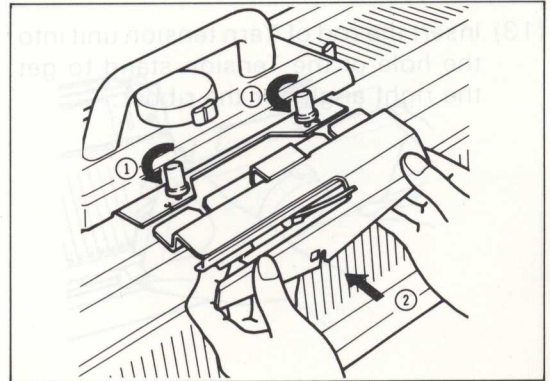

15

- (10) Fasten the thumb screws.

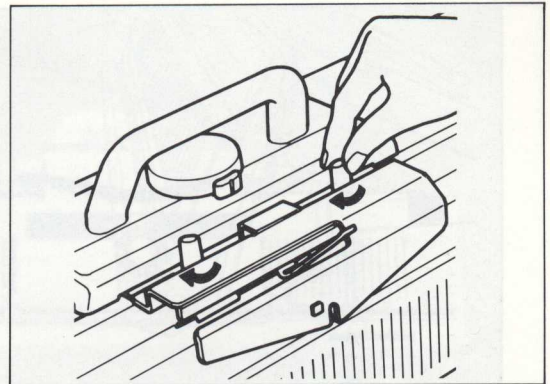

16

- (11) Hold the KR carriage and pass the K-carriage to the KR carriage so that both carriages are joined by the Connecting Arm.

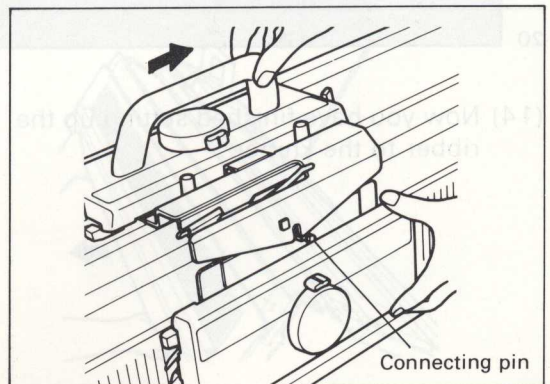

17

(12) Set the Tension stand to the yarn tension rod hole.

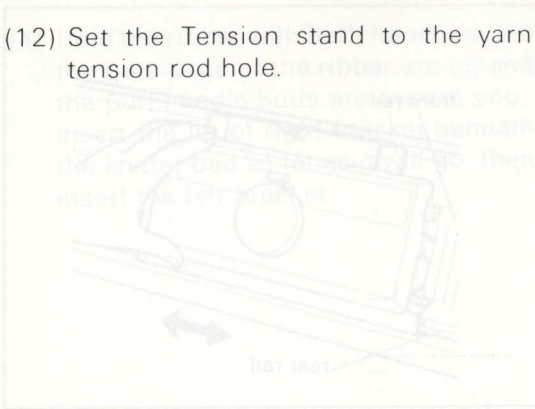

18

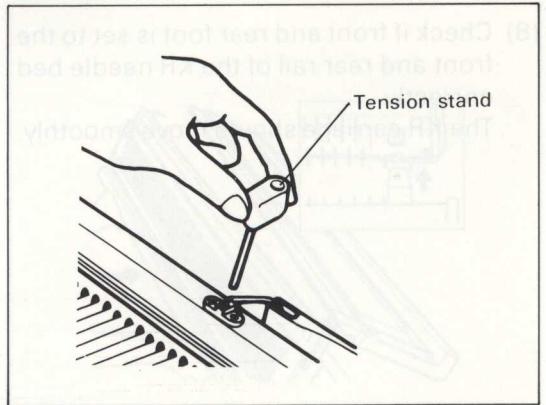

(13) Insert the rod of Yarn tension unit into the hole of the Tension stand to get the right angle for the ribber.

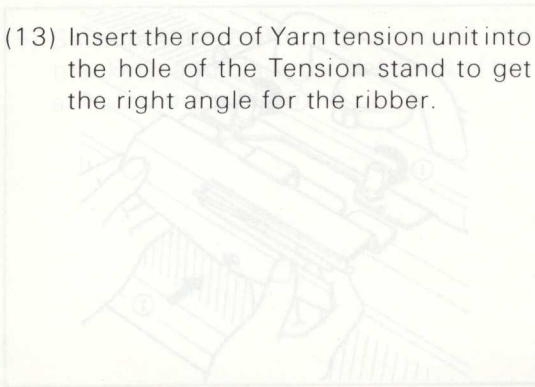

19

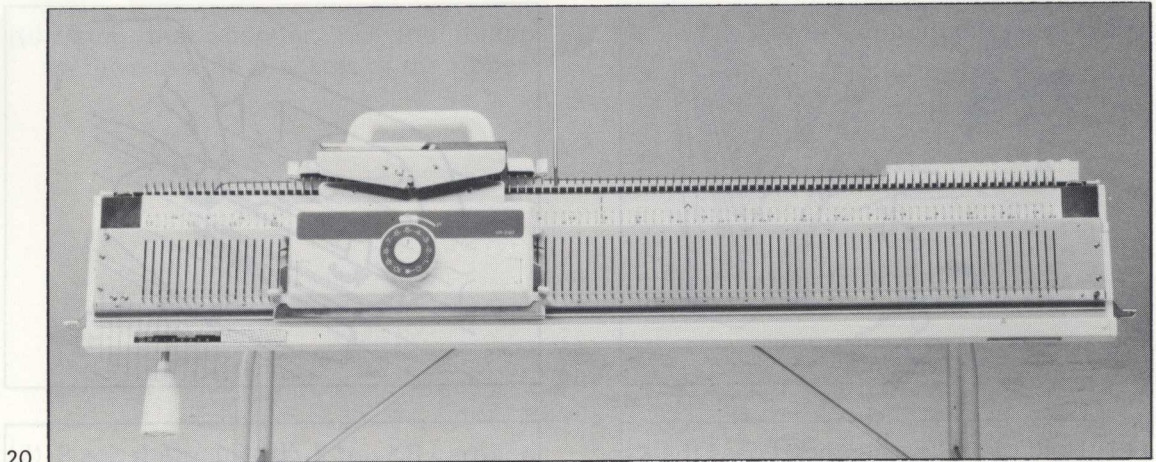
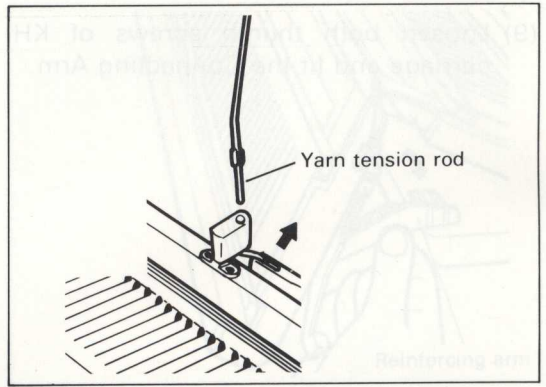

20

(14) Now you have finished setting up the ribber to the knitter.

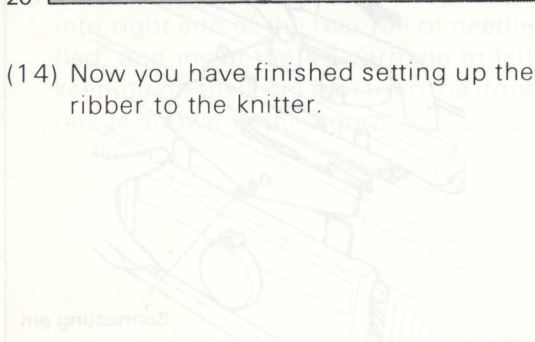

IV. TAKING OFF THE RIBBER FROM MACHINE

- (1) Take off the pressers on both sides, loosen the thumb screws.

By pushing up the connecting hook button with finger, pull the connecting arm towards you.

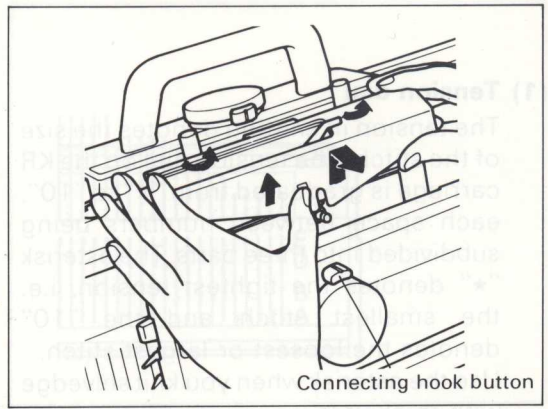
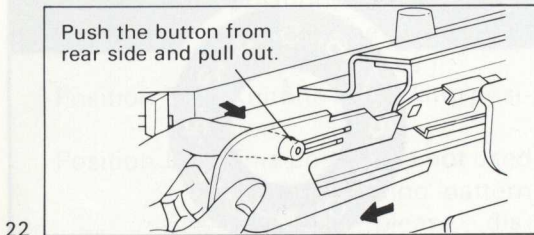

- (2) After disconnecting the KR carriage from the KH carriage, move the KR carriage to the end of the needle bed by keeping off the front foot from the needle bed as shown in the photograph.

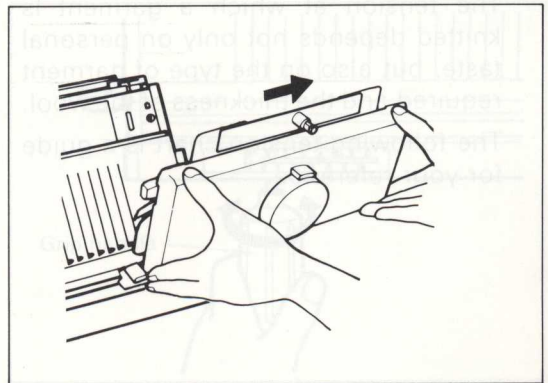

- (3) Loosen the screws and take off the KH clamps.

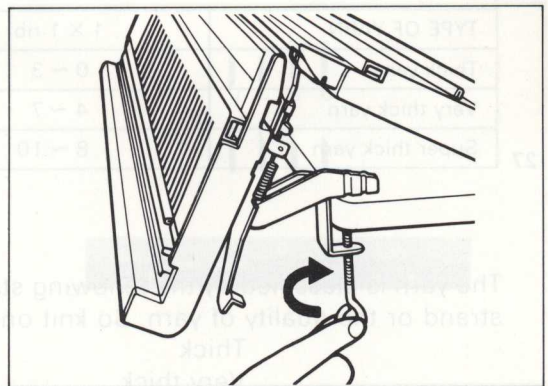

- (4) Hold up the lower side of the ribber a little and pull it toward you. You can take it off.

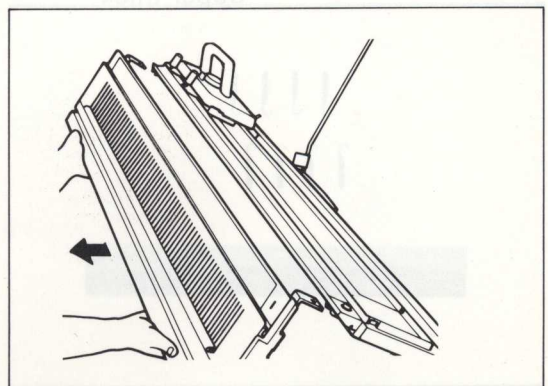

V. HERE ARE A FEW IMPORTANT POINTS TO REMEMBER BEFORE YOU START KNITTING

(1) Tension dial

The tension in knitting denotes the size of the stitch. The tension dial on the KR carriage is graduated from "★" to "10", each space between numbers being subdivided into three parts. The asterisk "★" denotes the tightest tension, i.e. the smallest stitch and the "10" denotes the loosest or largest stitch. Use the asterisk when you knit selvedge with thick yarn.

The tension at which a garment is knitted depends not only on personal taste, but also on the type of garment required and the thickness of the wool. The following tension chart is a guide for your reference.

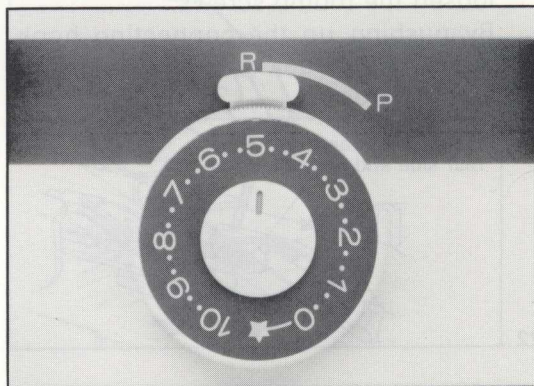

26

STANDARD TENSION CHART

TYPE OF YARN	1 × 1 rib	2 × 2 rib	full needle rib	circular
Thick yarn	0 ~ 3	1 ~ 4	1 ~ 4	1 ~ 4
Very thick yarn	4 ~ 7	5 ~ 8	—	5 ~ 8
Super thick yarn	8 ~ 10	8 ~ 10	—	—

27

The yarn is classified by the following standard. However, you had better think of the strand or the quality of yarn. So knit on trial and find your favorite stitch size.

Thick	115 ~ 125 m/50g
Very thick	80 ~ 100 m/50g
Super thick	50 ~ 65 m/50g

(2) Needle position

There are 4 positions on the needle bed of the ribber.

Position A: Resting or non-knitting position.
(against the base of the needle grooves.)

Position B: Knitting or working position.

Position D: This position is not used for any knitting pattern therefore please disregard.

Position E: Holding or partial knitting position.
Remove the pressers from the connecting arm in using this position.

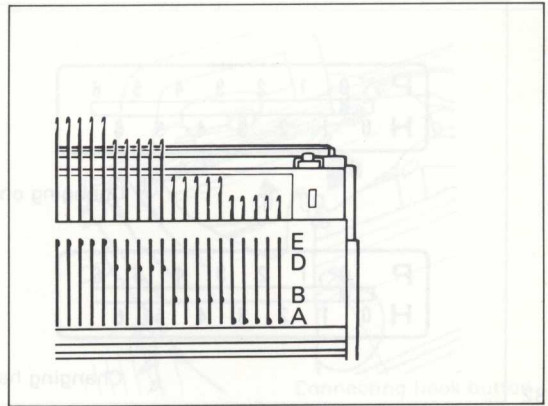

28

(3) Racking grip handle

Racking grip handle is used for making the "Racking patterns" and "Zigzag patterns". The racking position is indicated on the racking indicator. By turning the Grip handle, ribber bed is moved right or left. Normally, set the indicator to No. 3 which shows centre position.

There are two positions for setting, P and H.

Position P: Plain needles and purl needles (Upper scale) directly opposite to each other.

(Illustration is indicating the PO position)

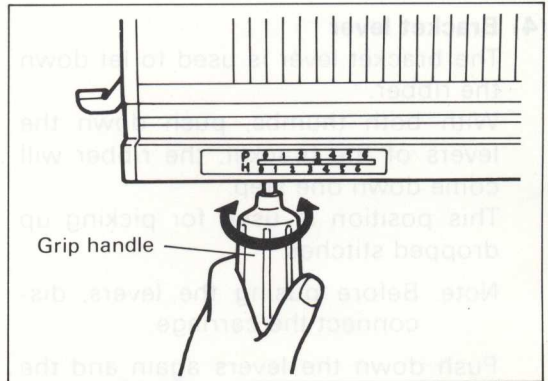

29

Position H: Purl needles are halfway (Lower scale) between two plain needles.

(Illustration is indicating the HO position)

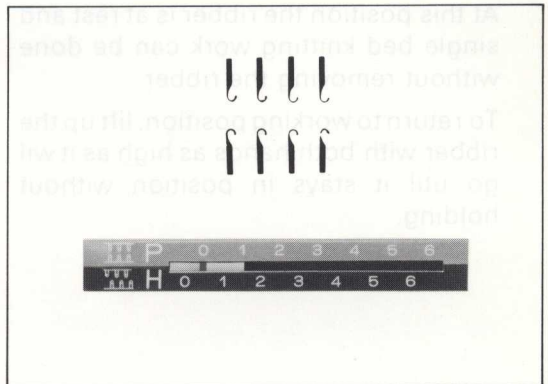

30

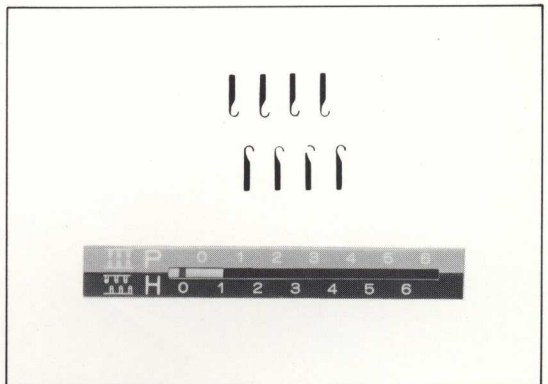

31

V. HERE ARE A FEW IMPORTANT POINTS TO REMEMBER BEFORE YOU START KNITTING

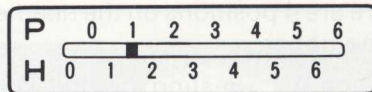
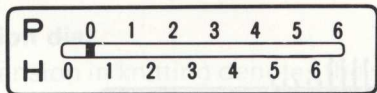

Changing one pitch from P0 to P1.

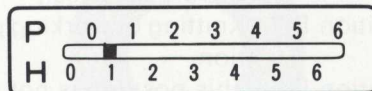
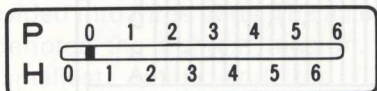

Changing half pitch from P0 to H1.

32

(4) Bracket lever

The bracket lever is used to let down the ribber.

With both thumbs, push down the levers of the bracket, the ribber will come down one step.

This position is used for picking up dropped stitches.

Note: Before pushing the levers, disconnect the carriage.

Push down the levers again and the ribber will come down one more step. At this position the ribber is at rest and single bed knitting work can be done without removing the ribber.

To return to working position, lift up the ribber with both hands as high as it will go until it stays in position without holding.

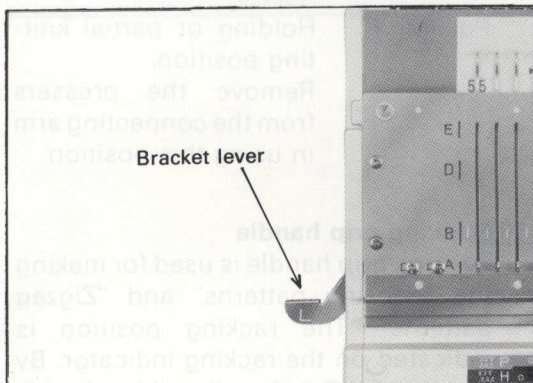

33

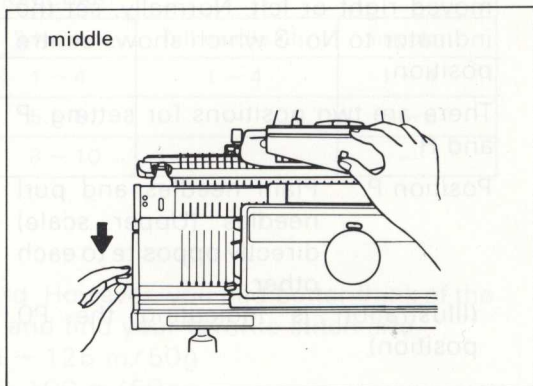

34

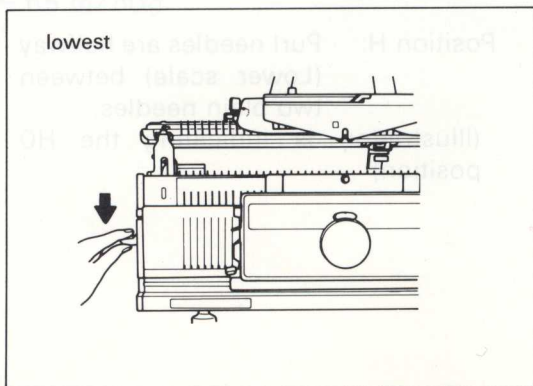

35

(5) Disconnecting the carriage

By pressing the connecting hook release button, lift up the front of the KH carriage so that you can disconnect the carriage.

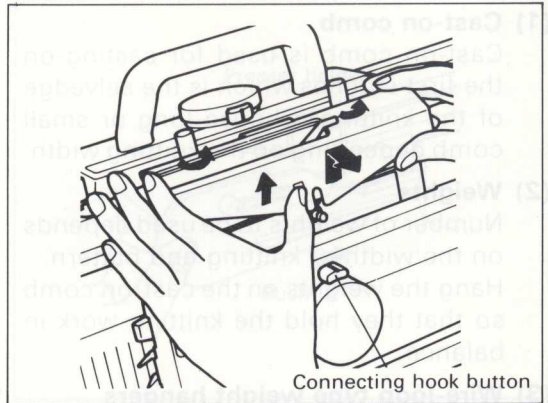

36



38

(8) Extension racks

Set the extension racks to each end of the bed.



39



38



40

VI. HOW TO USE THE ACCESSORIES

(1) Cast-on comb

Cast-on comb is used for casting-on the first stitches which is the selvedge of the knitting. Choose long or small comb depending on the knitting width.

(2) Weights

Number of weights to be used depends on the width of knitting and pattern. Hang the weights on the cast-on comb so that they hold the knitting work in balance.

(3) Wire-loop type weight hangers

The wire-loop type weight hangers are used for hanging small weights to give tension to the edges of the knitting work and also used as a small cast-on comb for casting-on work of less than 7 stitches.

(4) Work hook

The hook is used to pick up dropped stitches.

(5) Claw-type weight hangers

The claw type weight hangers are used to hang the small weights to give tension to the edge of the knitting work.

(6) Needle stoppers for K-carriage

Set the Needle stoppers onto the K carriage to prevent the needles from jamming with the Pressers.

To set the needle stopper, shift the H.C.L. knob to H position, then, insert the stopper. Return the H.C.L. knob to N position.

Set the Needle stoppers *after knitting the selvedge* for any pattern.

Standard weights chart

No. of stitches	Large weight	Small weight
~ 20	1	—
20 ~ 50	2	—
50 ~ 80	3	2
80 ~ 110	4	2

37

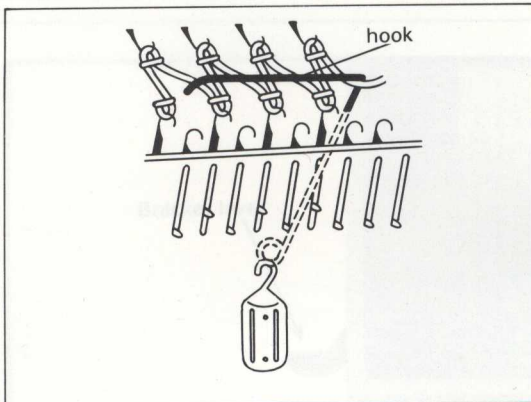

38

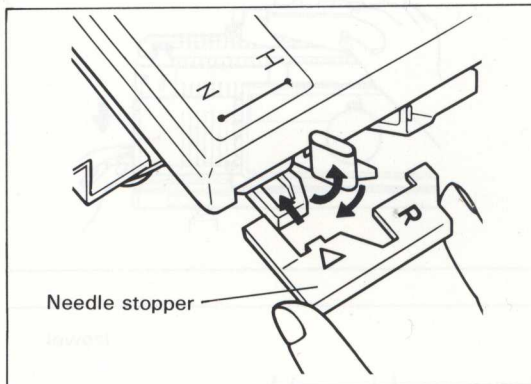

39

(7) Pressers

The pressers work for making the stitch correctly.

Set the pressers to both sides of the Connecting arm.

Set the pressers *after knitting the selvedge* for any pattern.

While the pressers are installed to connecting arm, do not leave any needles in position D nor E. If there are, the needles in D and E position might be caught by the presser and get damage.

(8) Extension racks

Set the extension racks to each end of the needle bed.

The extension rack works for changing the presser to working position when you knit with more than 45 (at each side) needles.

*When you remove the Extension rack, pull part **A** and take it off.

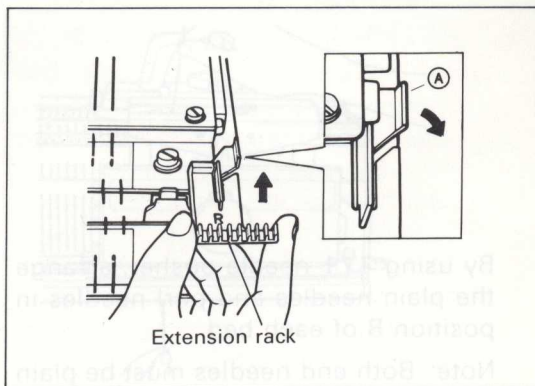
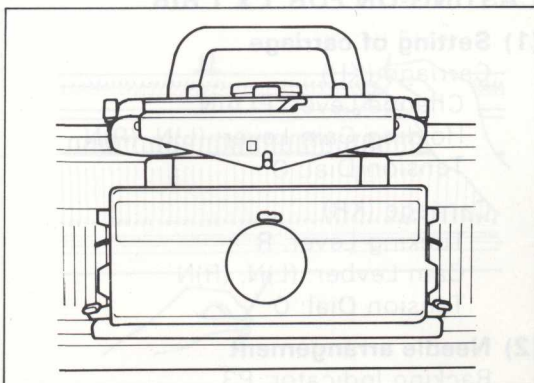
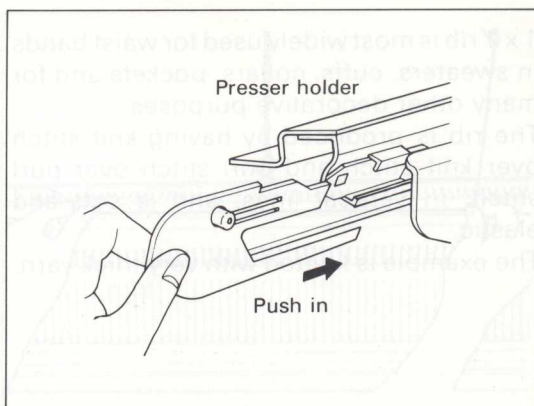

VII. HOW TO KNIT 1 x 1 RIB

1 x 1 rib is most widely used for waist bands in sweaters, cuffs, collars, pockets and for many other decorative purposes.

The rib is produced by having knit stitch over knit stitch and purl stitch over purl stitch, in vertical lines, and is soft and elastic.

The example is knitted with very thick yarn.

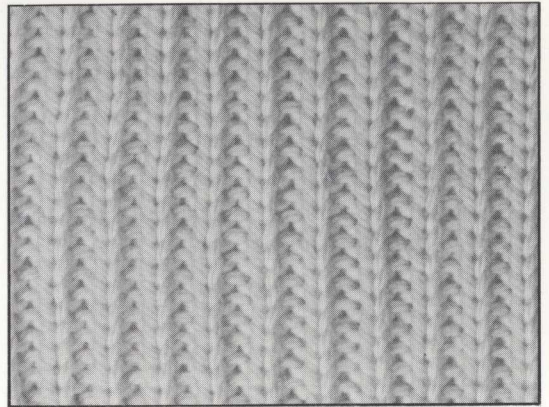

CASTING-ON FOR 1 x 1 RIB

(1) Setting of carriage

Carriage (KH)

Change Lever: PLAIN

Holding Cam Lever: (L)N, (R)N

Tension Dial: 0

Carriage (KR)

Tucking Lever: R

Cam Lever: (L)N, (R)N

Tension Dial: 0

(2) Needle arrangement

Racking Indicator: P3

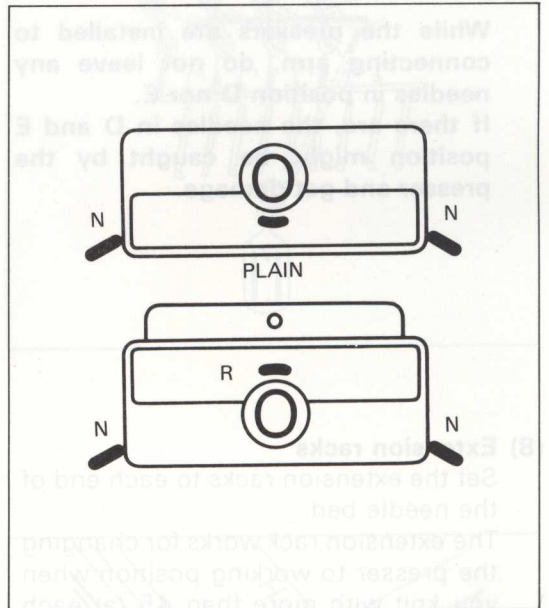

By using 1/1 needle pusher, arrange the plain needles and purl needles in position B of each bed.

Note: Both end needles must be plain needles.

By operating the connected carriage a few times over all arranged needles, the needles on KH and KR needle beds will be set in the line on position B.

Place the connected carriage at right end of the needle beds.

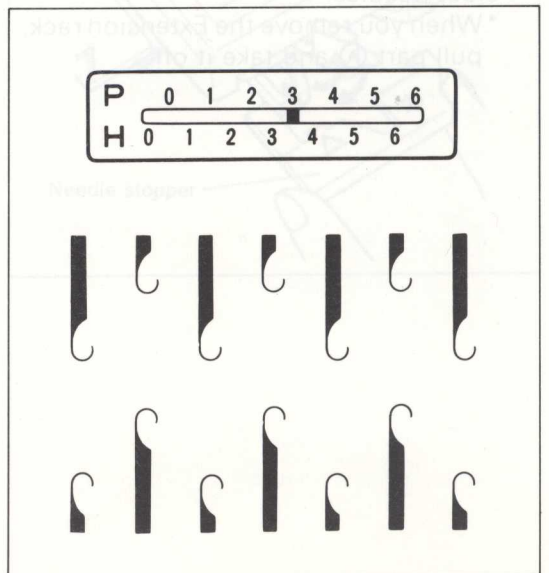

(3) First row knitting

- 1) Thread the yarn into the Yarn tension unit, and hold the end of yarn as shown in the Fig. 43.

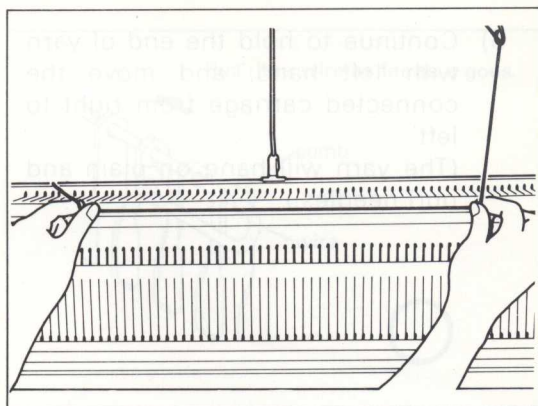

43

- 2) Pass the yarn between both gate pegs, and catch the end of yarn with left hand.

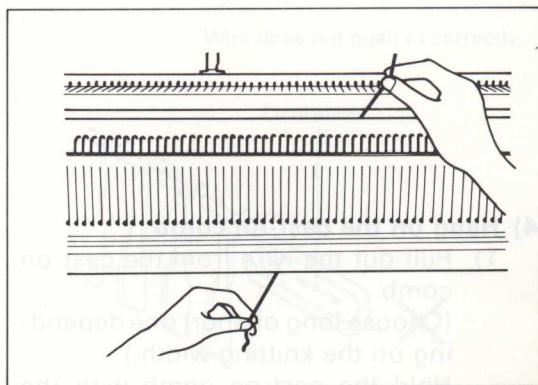

44

- 3) Hold the yarn with right hand (continue to hold the end of yarn with left hand), pass to the yarn feed. (see fig. 45.)

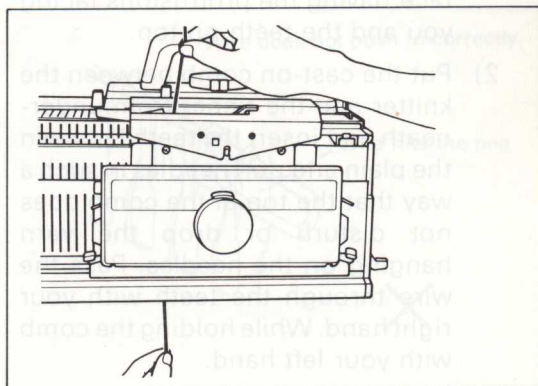

45

- 4) Pass the yarn into the yarn feeder securely.

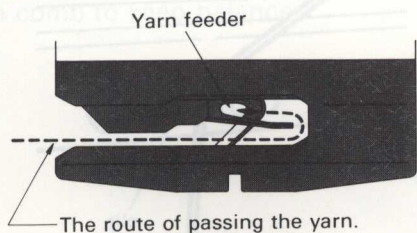

46

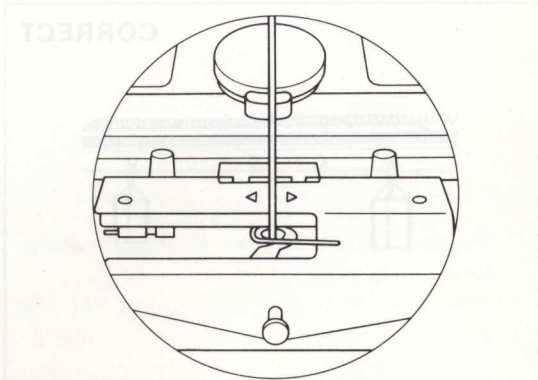

47

- 5) Continue to hold the end of yarn with left hand, and move the connected carriage from right to left.
 (The yarn will hang on plain and purl needles.)

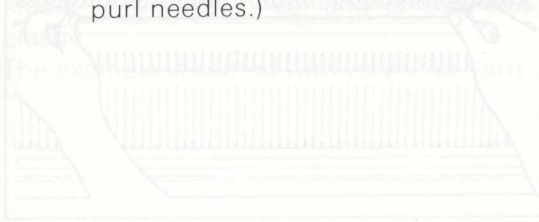

CASTING-ON FOR 1 x 1 RIB

1) Setting of carriage



(4) Hang on the cast-on comb

- 1) Pull out the wire from the cast-on comb.
 (Choose long or short one depending on the knitting width.)
 Hold the cast-on comb with the face having the protrusions facing you and the teeth on top.
- 2) Put the cast-on comb between the knitter and the ribber from underneath and insert the teeth between the plain and purl needles in such a way that the top of the comb does not disturb or drop the yarn hanging on the needles. Pass the wire through the teeth with your right hand. While holding the comb with your left hand.

CORRECT

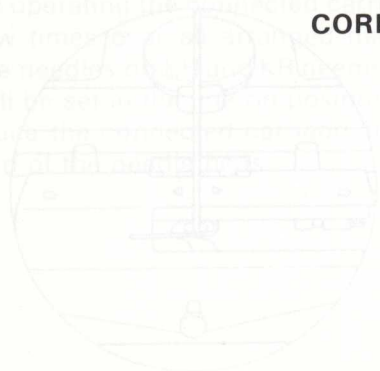

This mark shows the direction of the carriage.

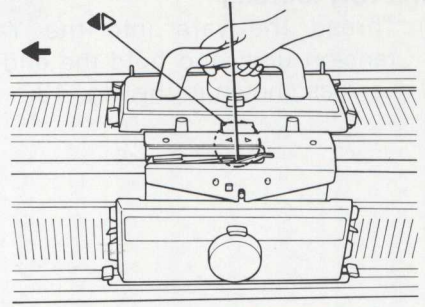

48

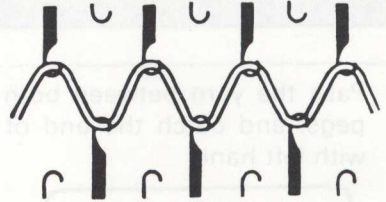

49

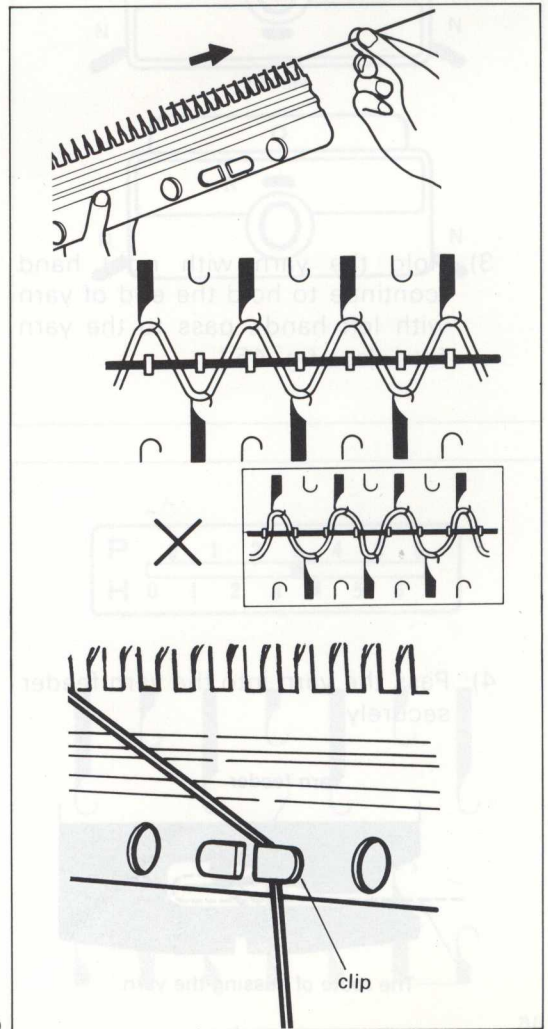

50

CORRECT

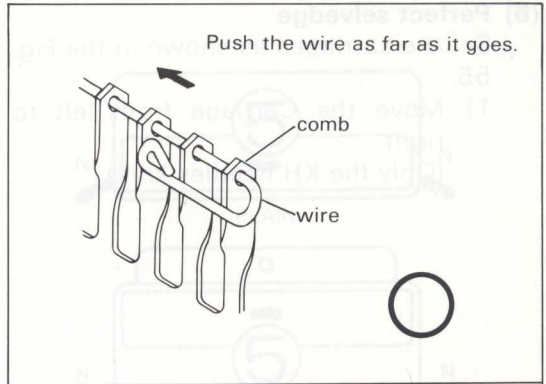

WRONG

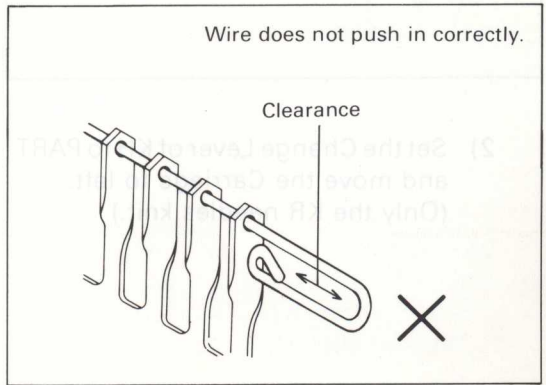

WRONG

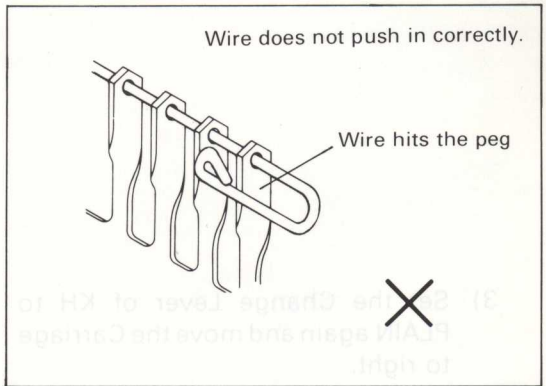

(5) Hang on the weights

Hang the weights as per Standard weights chart on page 13 on the cast-on comb to keep balance.

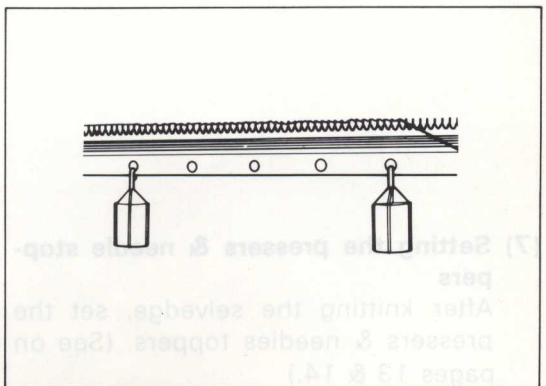

(6) Perfect selvedge

Set the carriages as shown in the Fig. 55.

- 1) Move the Carriage from left to right.
(Only the KH needles knit.)

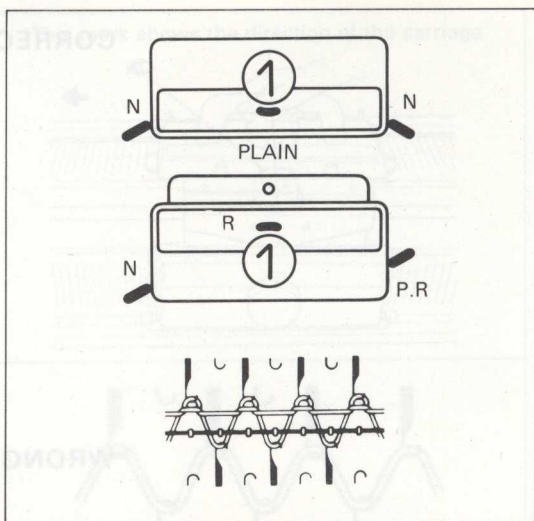

- 2) Set the Change Lever of KH to PART and move the Carriage to left.
(Only the KR needles knit.)

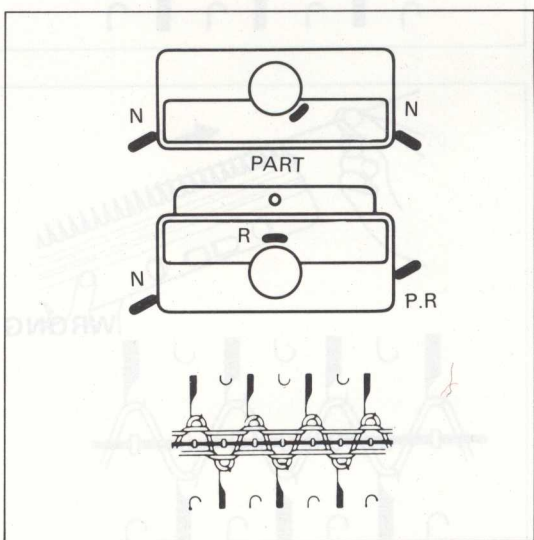

- 3) Set the Change Lever of KH to PLAIN again and move the Carriage to right.
(Only the KH needles knit)

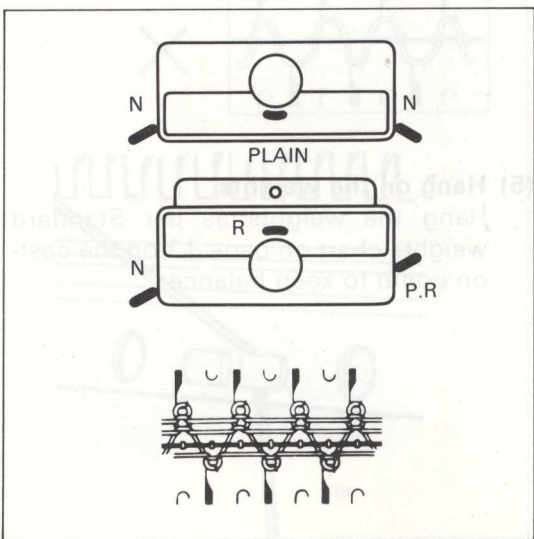

(7) Setting the pressers & needle stoppers

After knitting the selvedge, set the pressers & needles toppers. (See on pages 13 & 14.)

1 x 1 RIB KNITTING

After knitting the selvedge, set the carriages as shown in the Fig. 58.

Then, continue the knitting.

Note: Don't take the carriage back until you hear the "click" or the carriage passes the last working needle.

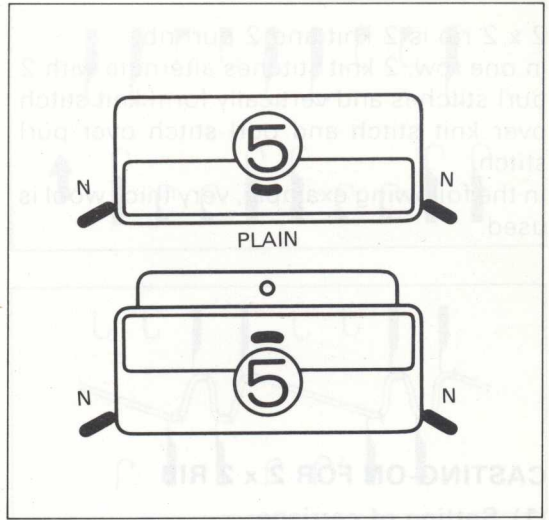

58

You are now able to do a finished end cast-on.

This method is very important, therefore please practice this cast-on two or three times.

If the carriage should jam while knitting, please refer to page 42 to release it.

VIII. HOW TO KNIT 2 x 2 RIB

2 x 2 rib is 2 knit and 2 purl rib.

In one row, 2 knit stitches alternate with 2 purl stitches and vertically form knit stitch over knit stitch and purl stitch over purl stitch.

In the following example, very thick wool is used.

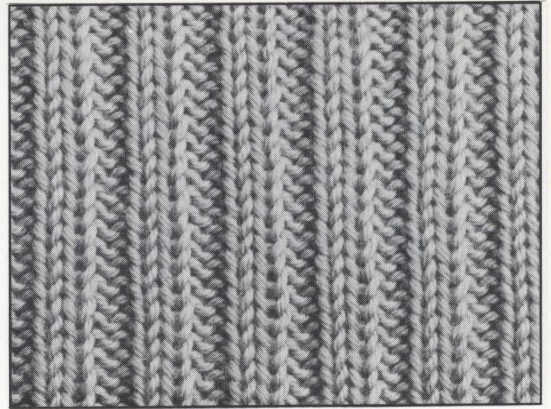

59

CASTING-ON FOR 2 x 2 RIB

(1) Setting of carriage

Carriage (KH)

Change Lever: PLAIN

Holding Cam Lever: (L)N, (R)N

Tension Dial: 0

Carriage (KR)

Tucking Lever: R

Cam Lever: (L)N, (R)N

Tension Dial: 0

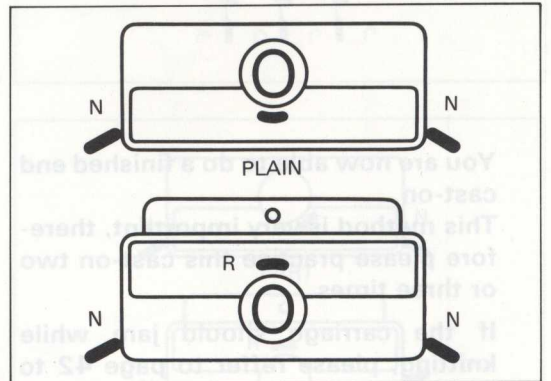

60

(2) Needle arrangement

Racking Indicator: P3

By using 2/2 needle pusher, arrange the plain needles and purl needles in position B of each bed. (See fig. 61)

Note: Both end needles must be plain needles.

Set the racking indicator on H2.

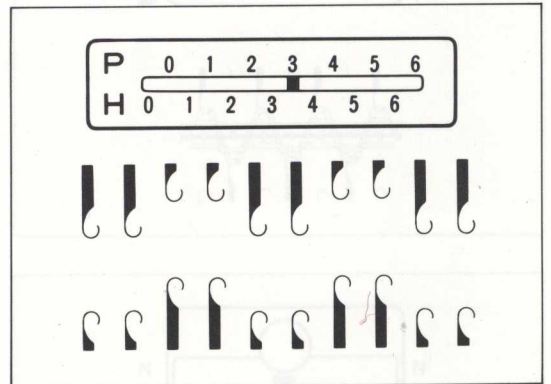

61

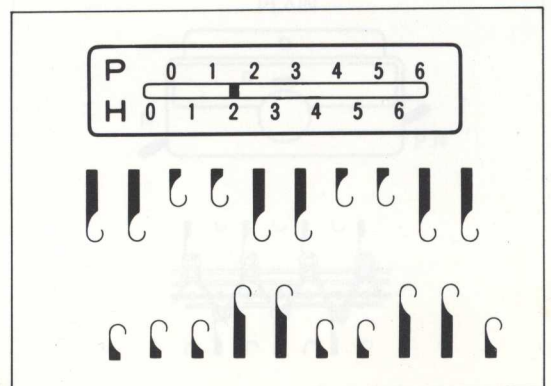

62

(7) Setting the pressers & needle stoppers
After knitting the edge, set the pressers & needle stoppers. (See on pages 13 & 14)

IX. HOW TO KNIT FULL NEEDLE RIB

- 1) Raise a purl needle in the left side to position B.
- 2) Move the connected carriage a few times over all arranged needles to set them in a line, then, place the carriage at right end of the bed.

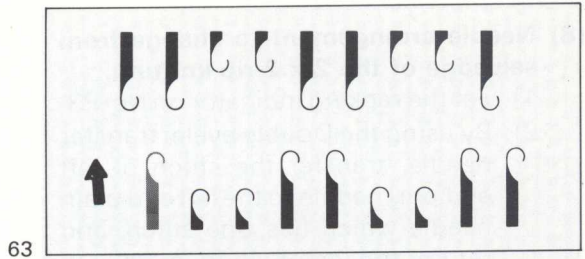

63

(3) First row knitting

- 1) Thread the yarn into the Yarn feeder.
- 2) Move the connected carriage from right to left. (The yarn will hang on plain and purl needles.)

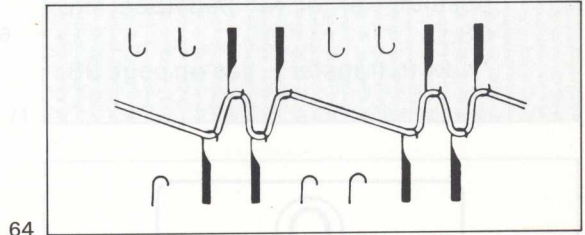

64

(4) Hang on the cast-on comb

* This is in the same way as 1 x 1 rib.

- 1) Hold the cast-on comb with the face having the protrusions facing you and the comb on top.
- 2) Put the cast-on comb between the knitter and the ribber from underneath and insert the comb between the yarn hanging on the needles. And pass the wire.

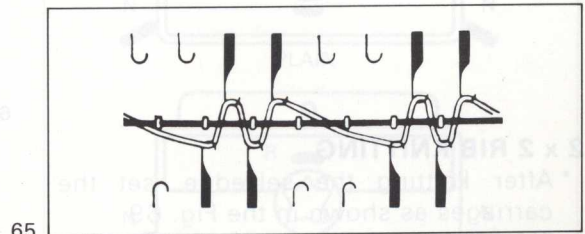

65

(5) Hang on the weights

Hang the weights as per Standard weights chart on page 13 on the cast-on comb to keep balance.

(6) Perfect selvedge

Set the carriages as shown in the Fig. 66.

- 1) Move the Carriage from left to right. (Only the KH needles knit.)
- 2) Set the Change Lever of KH to PART and move the Carriage to left. (Only the KR needles knit.)
- 3) Set the Change Lever of KH to PLAIN again and move the Carriage to right. (Only the KH needles knit)

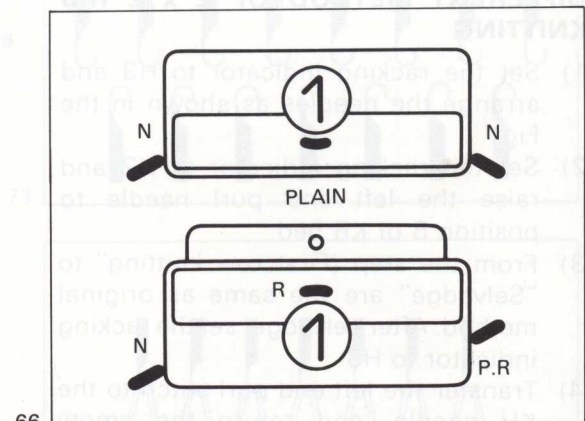

66

(7) Setting the pressers & needle stoppers

After knitting the selvedge, set the pressers & needles toppers. (See on pages 13 & 14.)

VIII. HOW TO KNIT 2 x 2 RIB

(8) Needle arrangement to change from selvedge of the 2 x 2 rib knitting.

- 1) set the racking indicator on No. P3.
- 2) By using the Double eyelet transfer needle, transfer the stitch of left end purl needle to the left end plain needle which has one stitch, and return the empty purl needle to position "A" of KR bed (See Fig. 68.)

*How to transfer ... see on page 38.

67

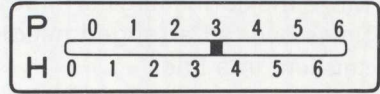

68

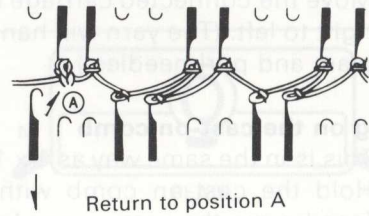

69

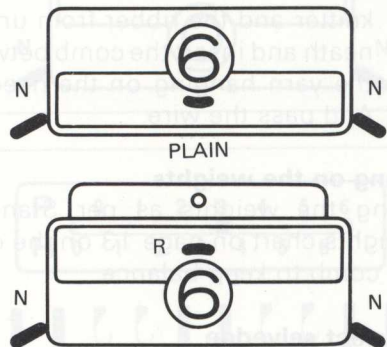

2 x 2 RIB KNITTING

*After knitting the selvedge, set the carriages as shown in the Fig. 69. Then, continue the knitting.

DIFFERENT METHOD OF 2 x 2 RIB KNITTING

- 1) Set the racking indicator to H3 and arrange the needles as shown in the Fig.
- 2) Set the racking indicator to H2 and raise the left end purl needle to position B of KR bed.
- 3) From the step ("First row knitting" to "Selvedge") are the same as original method. After selvedge, set the racking indicator to H3.
- 4) Transfer the left end purl stitch to the KH needle, and return the empty needle (KR) to position A of KR bed.
- 5) Set the pressers & needle stoppers.
- 6) The knitting is the same as original method.

70

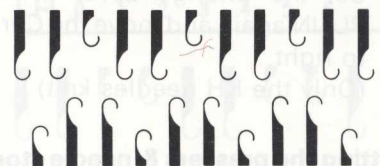
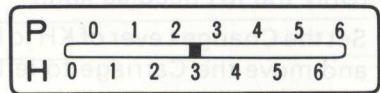

IX. HOW TO KNIT FULL NEEDLE RIB

Knitting method of full needle rib is the same as for 1 x 1 rib. Difference is the needle arrangement only. In 1 x 1 rib every other needle is used but in full needle rib, all needles are used.

The example is knitted with thick wool.

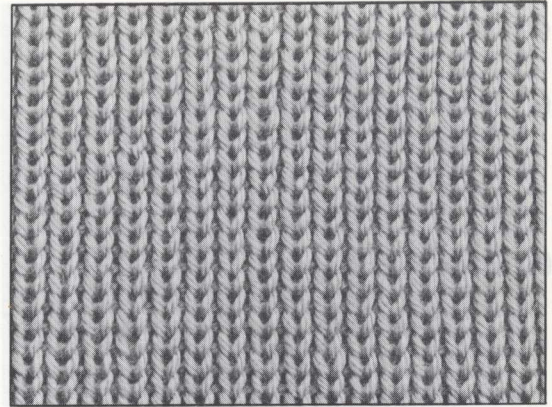

71

CASTING-ON FOR FULL NEEDLE RIB

(1) Setting of carriage

Carriage (KH)

Change Lever: PLAIN

Holding Cam Lever: (L)N, (R)N

Tension Dial: 0

Carriage (KR)

Tucking Lever: R

Cam Leber: (L)N, (R)N

Tension Dial: ☆

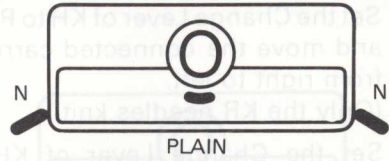

72

(2) Needle arrangement

Racking Indicator: H3

Arrange the plain and purl needles in position B of each bed.

Note: Both end needles must be plain needles.

Move the connected carriage a few times over all arranged needles to set them in a line. Then place the carriage at right end of the bed.

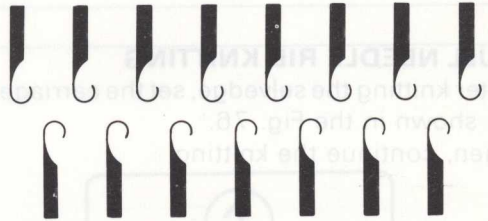
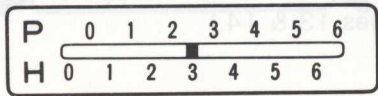

73

(3) First row knitting

1) Thread the yarn into the Yarn feeder.

2) Move the connected carriage from right to left. (The yarn will hang on plain and purl needles.)

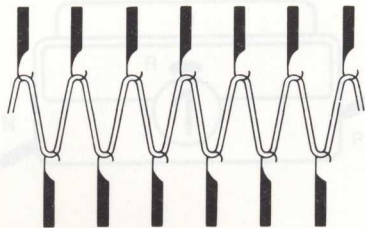

74

(4) Hang on the cast-on comb

This is the same as 1 x 1 rib.

(5) Hang on the weights

Hang the weights as per Standard weights chart on page 13 on the cast-on comb to keep balance.

(6) Perfect selvedge

Set the carriages as shown in the Fig. 75.

- 1) Move the connected carriage from left to right.
(Only the KH needles knit.)
- 2) Set the Change Lever of KH to PART and move the connected carriage from right to left.
(Only the KR needles knit.)
- 3) Set the Change Lever of KH to PLAIN again and move the connected carriage from left to right.
(Only the KH needles knit)

(7) Setting the pressers & needle stoppers

After knitting the selvedge, set the pressers & needle stoppers. (See on pages 13 & 14.)

FULL NEEDLE RIB KNITTING

After knitting the selvedge, set the carriages as shown in the Fig. 76. Then, continue the knitting.

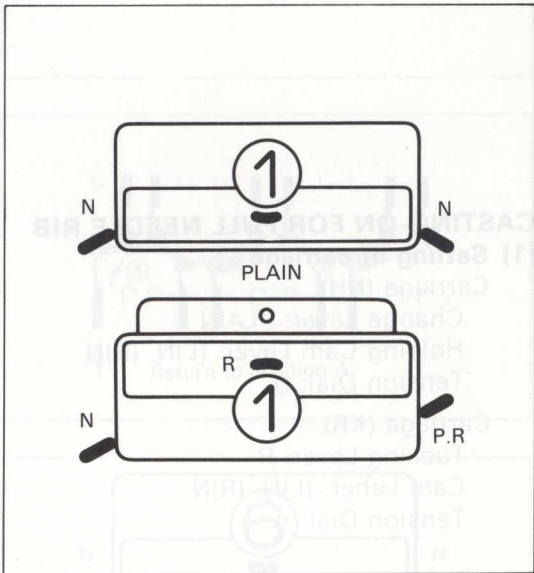
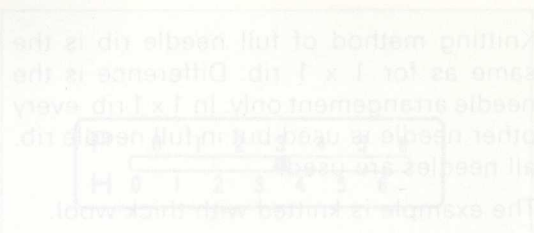

75

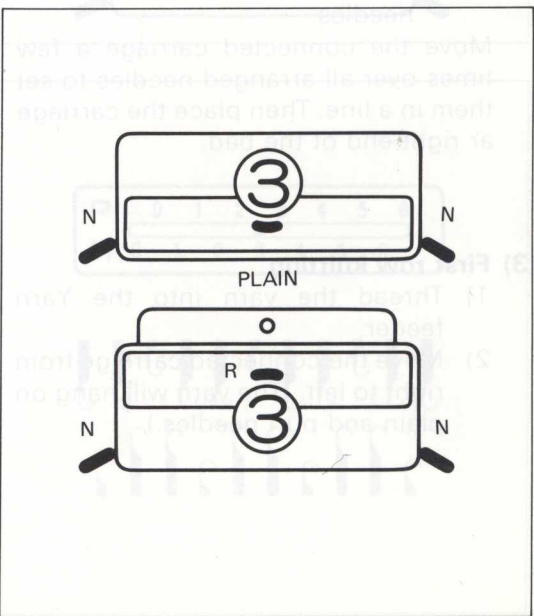

76

X. HOW TO KNIT 5 x 5 RIB R KNITTING

5 x 5 rib is called 5 knit 5 purl rib. In one row, there are 5 knit stitches alternating with 5 purl stitches, and vertically, from knit stitch over knit stitch and purl stitch over purl stitch.

The following example is knitted with thick wool.

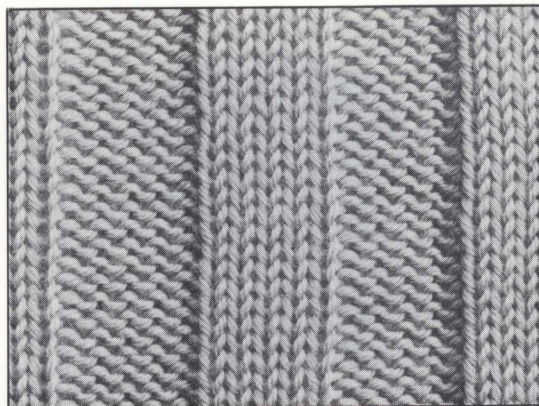

77

CASTING-ON FOR 5 x 5 RIB

(1) Setting of carriage

Carriage (KH)

Change Lever: PLAIN

Holding Cam Lever: (L)N, (R)N

Tension Dial: 0

Carriage (KR)

Tucking Lever: R

Cam Lever: (L)N, (R)N

Tension Dial: ☆

- (2) "Needle arrangement", "First row knitting", "Hang on the cast-on comb" and "Hang on the weights" are the same as full needle rib.

78

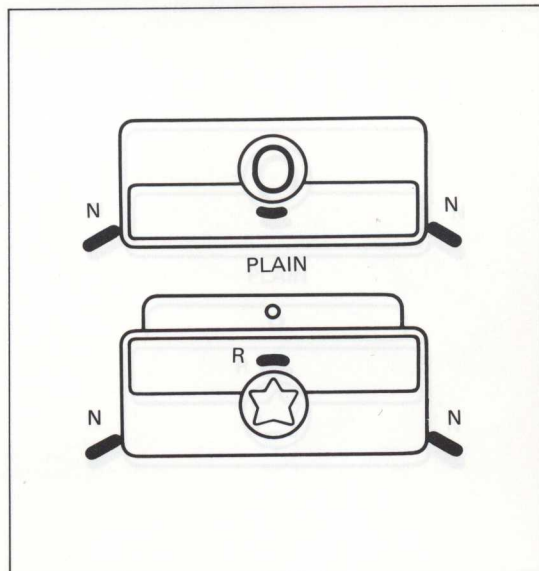

(3) First row knitting

(3) Perfect selvedge

Set the carriages as shown in the figure.

- 1) Move the connected carriage from left to right.
(Only the KH needles knit.)
- 2) Set the Change Lever of KH to PART and move the connected carriage from right to left.
(Only the KR needles knit.)
- 3) Set the Change Lever of KH to PLAIN again and move the connected carriage from left to right.
(Only the KH needles knit.)

(4) Setting the pressers & needle stoppers

After knitting the selvedge, set the pressers & needle stoppers. (See on pages 13 & 14.)

79

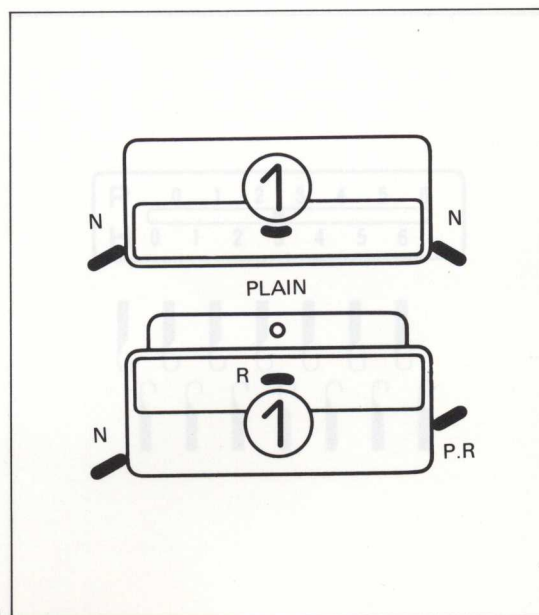

5 x 5 RIB KNITTING

- 1) After knitting the selvedge, by using the Double eyelet transfer needle, transfer the stitches to corresponded needles, and return the empty needles to position A of each bed (See Fig. 80).
- 2) Set the carriages as shown in the Fig. 81.
Then, continue the knitting.

Hang the claw type weight hangers and small weights at both edges of the knitting work.

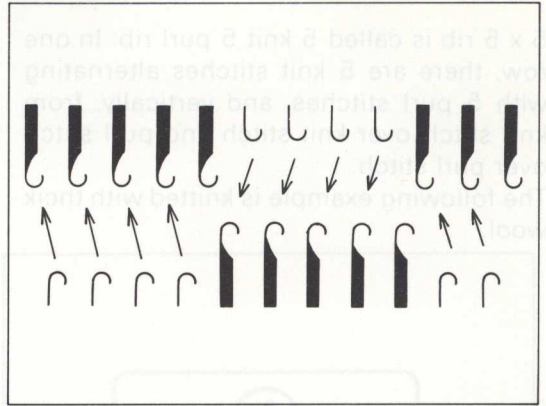

80

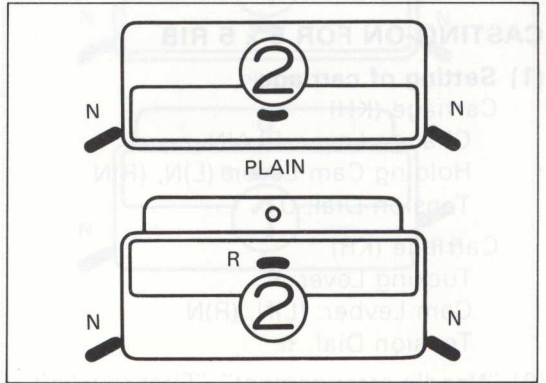

81

XI. HOW TO KNIT CIRCULAR KNITTING

Circular knitting is made up of only plain knit stitches, and is a jointless tube. Size of tube depends on the number of needles. Before you start to knit the garment, make the test piece to check the tension gauge. If there is slacken on the side, please adjust by the tension dial on the KR carriage. The example is knitted with thick wool.

CASTING-ON FOR CIRCULAR KNITTING

(1) Setting of carriages

Carriage (KH)

Change Lever: PLAIN

Holding Cam Lever: (L)N, (R)N

Tension Dial:

Carriage (KR)

Tucking Lever: R

Cam Leber: (L)N, (R)N

Tension Dial:

(2) Needle arrangement

1) Racking Indicator: H3

2) Arrange the plain and purl needles in position B of each bed.

Note: The number of needles between plain and purl needles must be same.

3) Move the connected carriage a few times over all arranged needles to set them in a line. Then, place the carriage at right end of the bed.

(3) First row knitting

1) Thread the **Cast-on thread** provided in the accessories of KH into the yarn feeder.

2) Move the connected carriage from right to left. (The cast-on thread will hang on plain and purl needles.)

(4) Hang on the cast-on comb

This is the same as 1 x 1 rib.

(5) Hang on the weights

Hang the weights as per Standard weights chart on page 13 on the cast-on comb to keep balance.

(6) Perfect selvedge

Remove the cast-on thread from the yarn feeder, and rethread the knitting yarn into the feeder.

(7) Setting the pressers & needle stoppers

After knitting 3-4 rows, set the pressers & needle stoppers. (See on pages 13 & 14.)



82

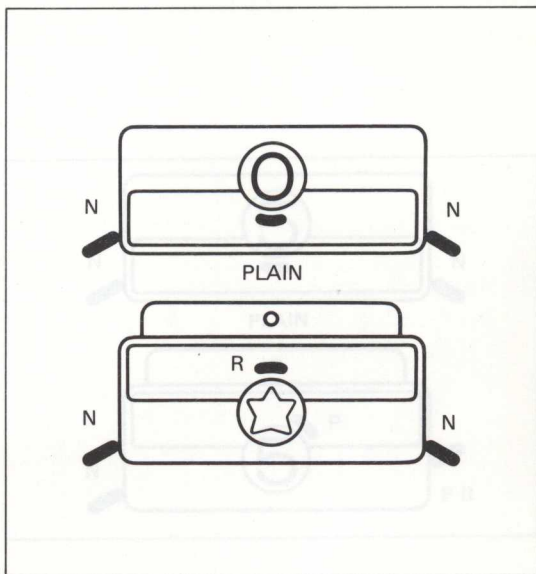

83

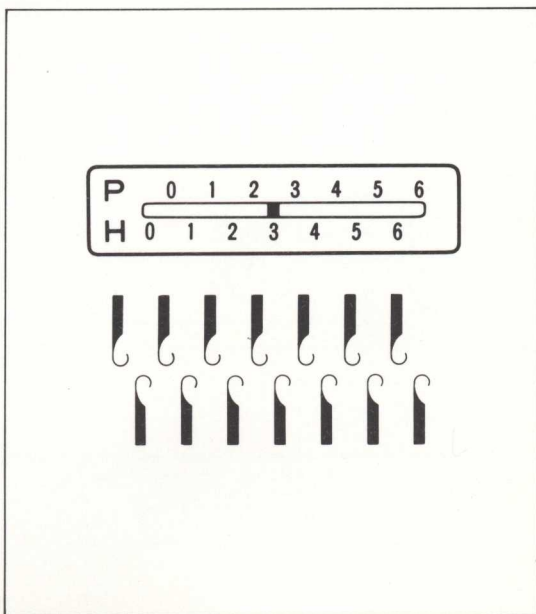

84

CIRCULAR KNITTING

- 1) Set the carriages as shown in the Fig. 85 and move the connected carriage to right.
- 2) Set the Change Lever of KH to PART (fig. 86) and move the connected carriage to left.
- 3) Repeat 1 ~ 2 steps.

85

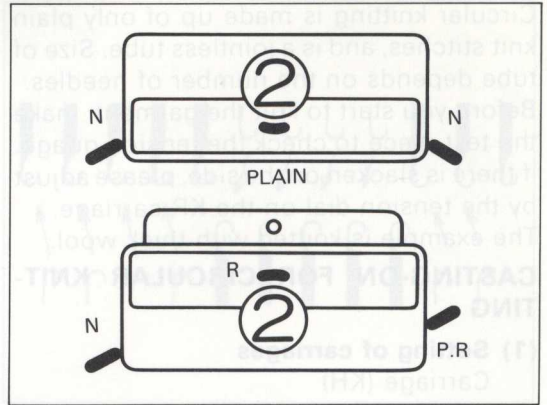

86

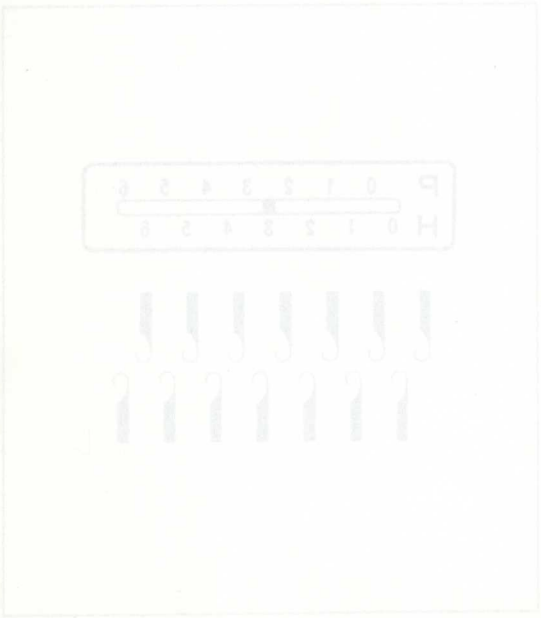
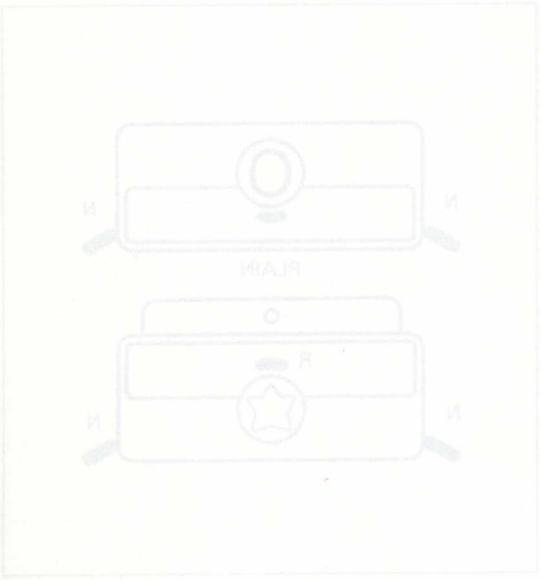
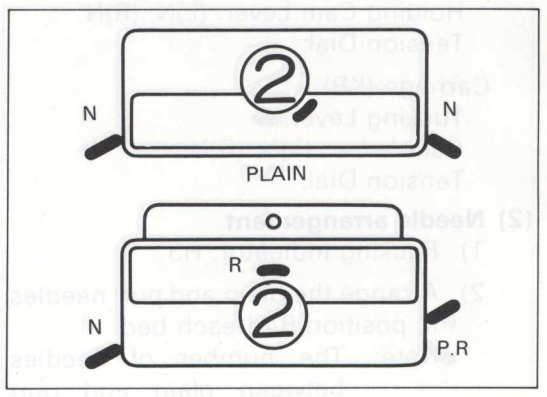

XII. HOW TO KNIT ENGLISH RIB

English rib is a variety of 1 x 1 rib, and knitter side is plain stitch but ribber side is tuck stitch.

The example is knitted with very thick wool.

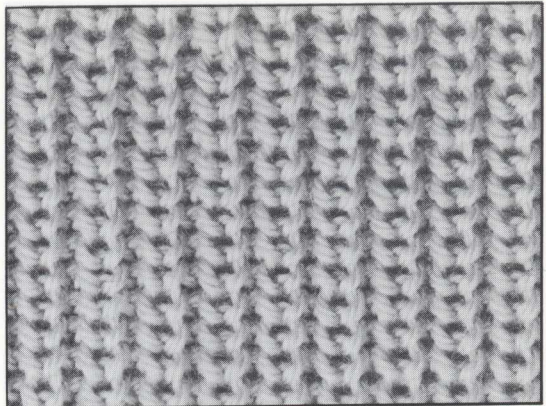

87

CASTING-ON FOR ENGLISH RIB

- * This is the same as for 1 x 1 rib.
- * Set the pressers & needle stoppers.

ENGLISH RIB KNITTING

- * Set the carriages as shown in the Fig. 88 and continue the knitting.

Note: Hang the wire-loop type weight hangers and small weights on the edges of the knitting work to avoid stitch dropping.

How to use ... see on page 13.

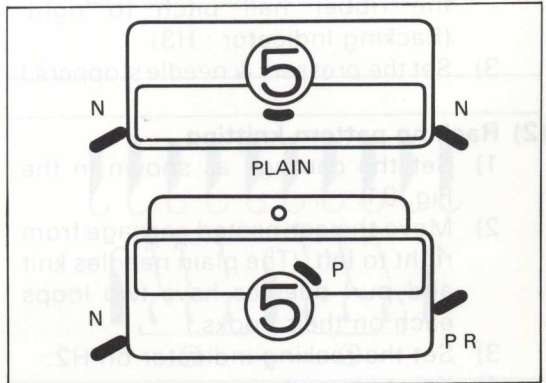

88

XIII. HOW TO KNIT RACKING PATTERN OF ENGLISH RIB

The example is knitted with very thick wool.

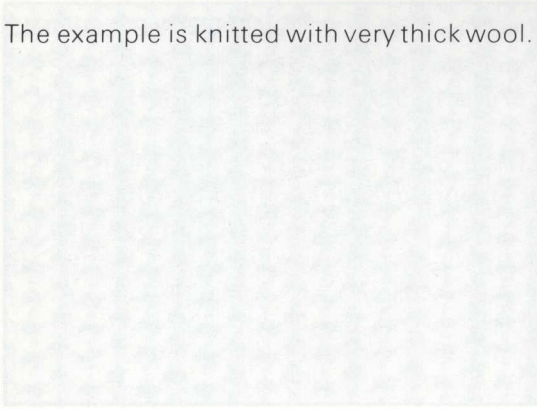

89

(1) Casting-on for racking pattern of English rib

- 1) This is the same as for 1/1 rib.
- 2) After knitting the selvedge swing the ribber half pitch to right. (Racking Indicator : H3)
- 3) Set the pressers & needle stoppers.)

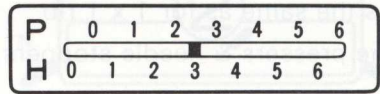

90

(2) Racking pattern knitting

- 1) Set the carriage as shown in the Fig. 91.
- 2) Move the connected carriage from right to left. (The plain needles knit and purl needles have two loops each on their hooks.)
- 3) Set the racking indicator on H2.
- 4) Knit two rows.
- 5) Set the racking indicator H3.
- 6) Move the connected carriage from left to right. (One row)
- 7) Repeat step 2) to 6).

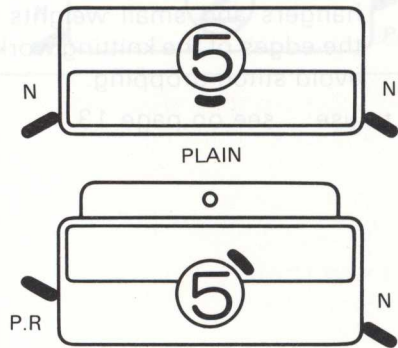

91

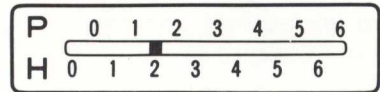

92

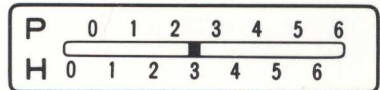

93

XIV. HOW TO KNIT RACKING PATTERN (I)

The example is knitted with thick wool.

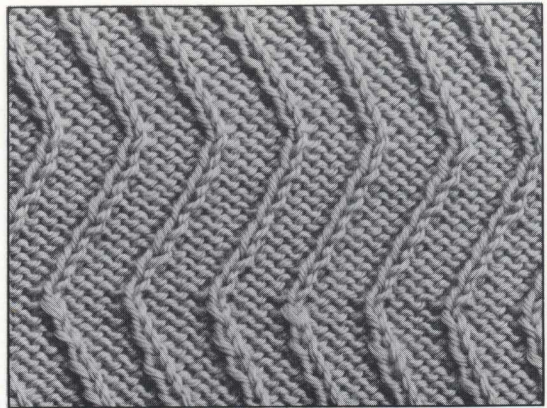

94

(1) Casting-on for racking pattern (I)

- * Set the racking indicator on H0.
- The other steps are the same as for full needle rib.
- * Set the pressers & needle stoppers.

(2) Racking pattern (I) knitting

- 1) After knitting the selvedge, using the Double eyelet transfer needle, transfer the part (A) stitches to opposite plain needles, and return the empty needles to position A of KR bed.
- 2) Set the carriages as shown in the Fig.
- 3) Move the connected carriage from right to left. (The plain and purl needles knit.)
- 4) Set the racking indicator on H1.
- 5) Move the connected carriage from left to right.
- 6) Set the racking indicator on H2.
- 7) Continue the same manner until the racking indicator indicates H6.
- 8) Move the connected carriage from right to left.

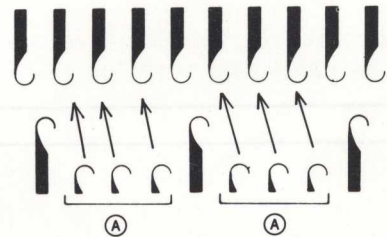
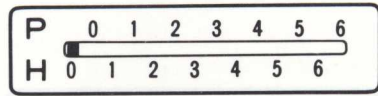

95

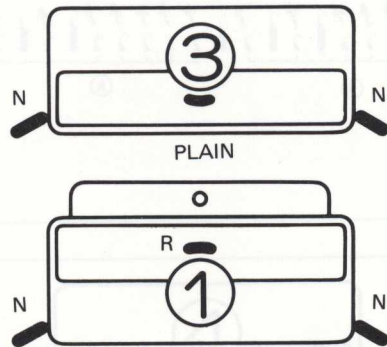

96

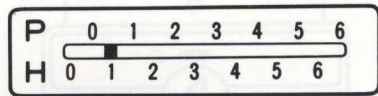

97

- 9) Set the racking indicator on H5.
- 10) Continue the same manner until the racking indicator indicates H0.
- 11) The pattern knitted from step 3) to 10) is one cycle.

Note: Don't turn the racking grip handle when the needles are raised over the gate pegs.

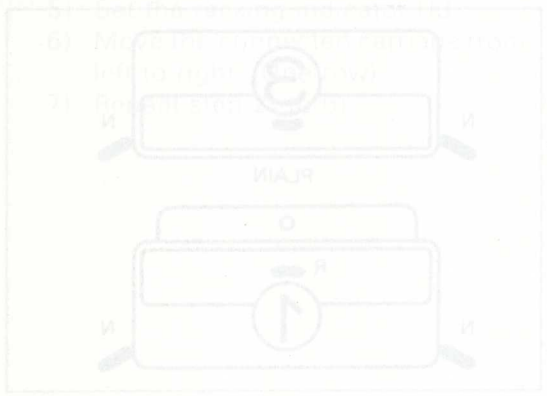
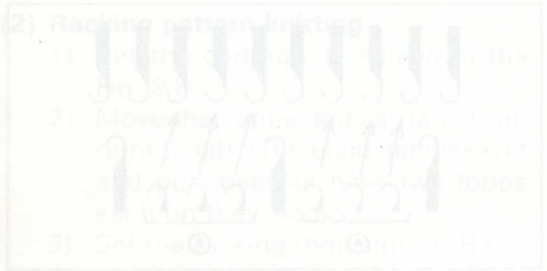
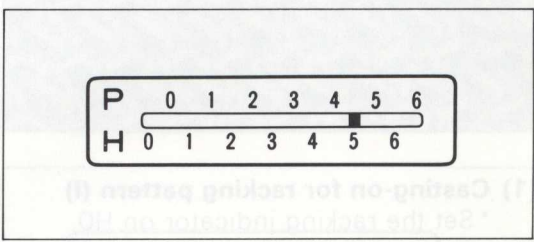
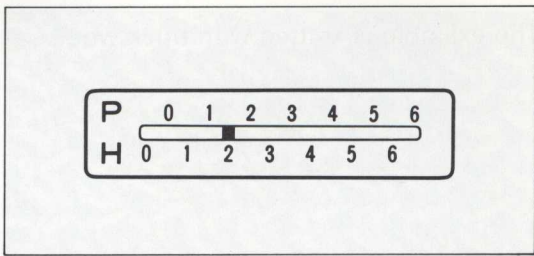

XV. HOW TO KNIT RACKING PATTERN (II)

The example is knitted thick wool.

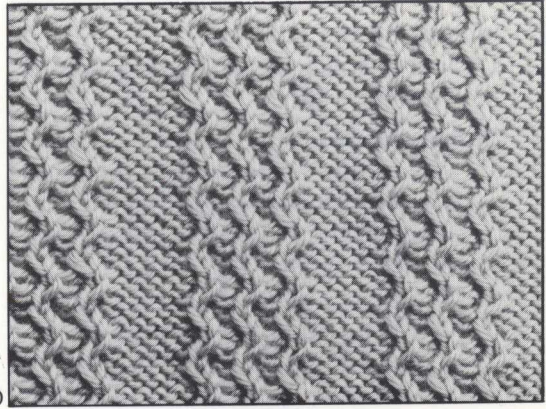

100

(1) Casting-on for racking pattern (II)

- * This is the same as for full needle rib.
- * Set the racking indicator on H3.
- * Set the pressers & needle stoppers.



101

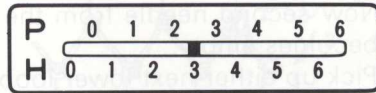

(2) Racking pattern (II) knitting

- 1) After knitting the selvedge, using the Double eyelet transfer needle, transfer the part (A) stitches to opposite plain needles, and return the empty needles to position A of KR bed.
- 2) Set the carriage as shown in the Fig.
- 3) Move the connected carriage from right to left.
- 4) Move the connected carriage from left to right.
- 5) Set the racking indicator on H5.
- 6) Move the connected carriage from right to left.
- 7) Move the connected carriage from left to right.
- 8) Set the racking indicator on H3.
- 9) Repeat the step 3) to 8).

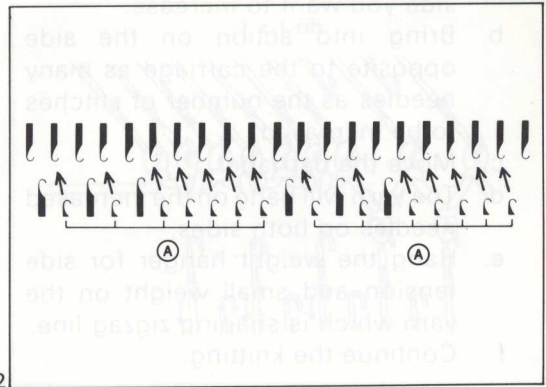

102

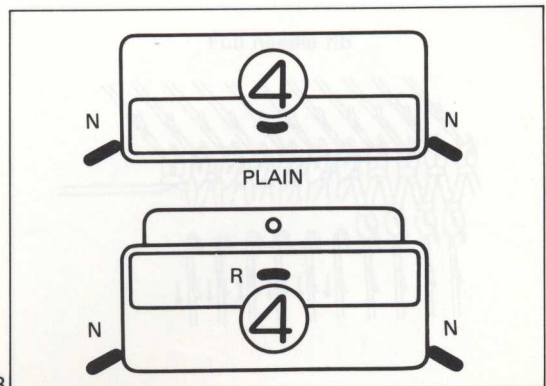

103

XVI. MAKING GARMENTS

(1) Increasing the stitches

1) Increasing one stitch on one side of knitting width.

Simple method

- Place the carriage on the side which you want to increase.
- Raise the end needle to the working position B. (see Fig. 104)
- The empty needle will pick up the yarn as it knits the next row.

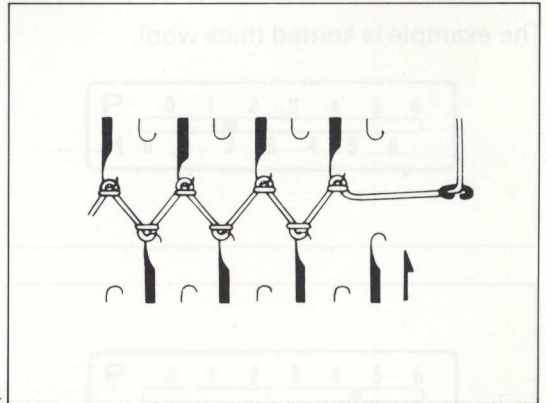

104

Full fashioned method

- Use the transfer needle, move the first stitch (1) onto the adjacent empty needle (2). Now second needle from the end becomes empty.
- Pick up either next lower loop (3), and hook on the empty needle (1).

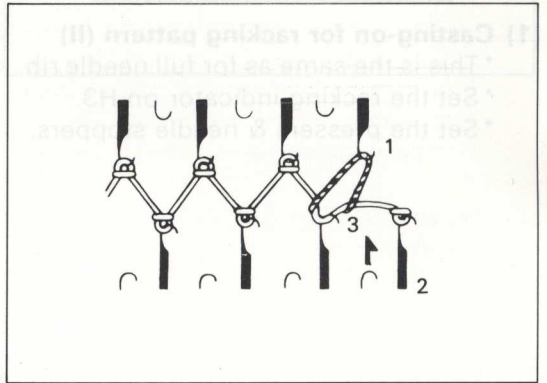

105

2) Increasing more than two stitches on either side of the garment.

- Place the carriage opposite to the side you want to increase.
- Bring into action on the side opposite to the carriage as many needles as the number of stitches to be increased.
- Move the carriage.
- The yarn will hang on the increased needles on both sides.
- Hang the weight hanger for side tension and small weight on the yarn which is shaping zigzag line.
- Continue the knitting.



(2) Decreasing the stitches

1) Decreasing one stitch on either end.

Simple method

* By using the transfer needle, transfer the end stitch to the second needle, and take the empty needle out of action.

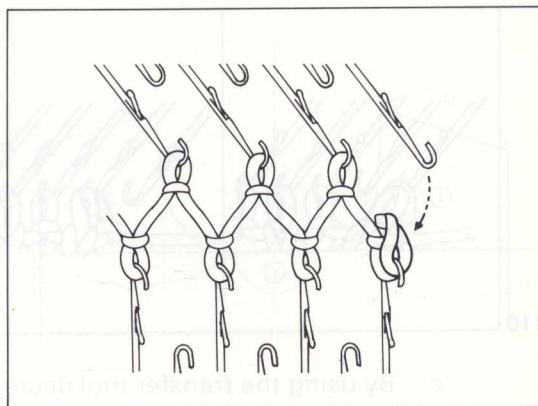

106

Second method

- Use the transfer needle. Transfer the end stitch to the second needle and the second needle to the third needle.
- Take the empty needle out of action.

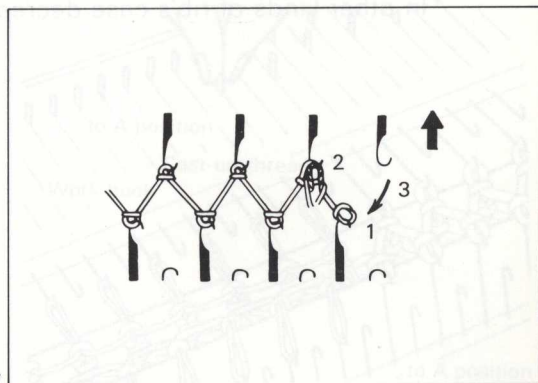

107

2) Decreasing more than two stitches

If you decrease more than two stitches, decrease them at the side where the carriage is placed to avoid the stitches becoming too tight.

In this method decrease them in the KH side.

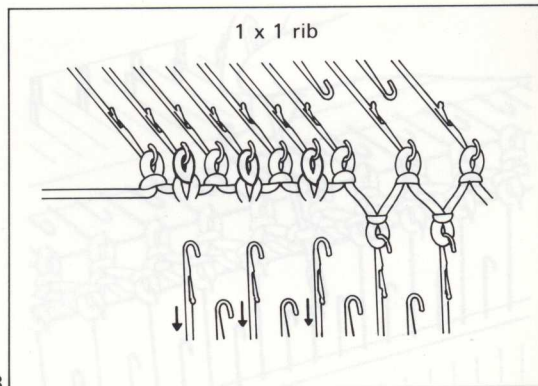

108

- Transfer the stitches of KR side that you want to decrease to the KH needles.
- Return the empty needles to position A.

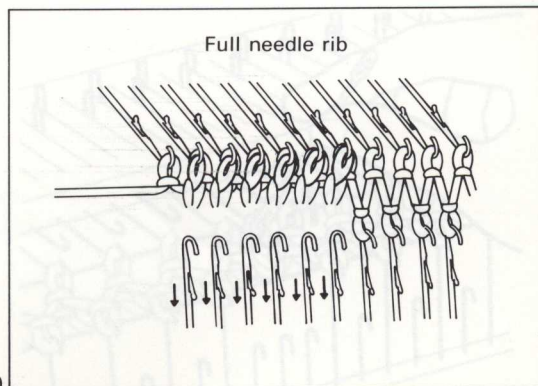

109

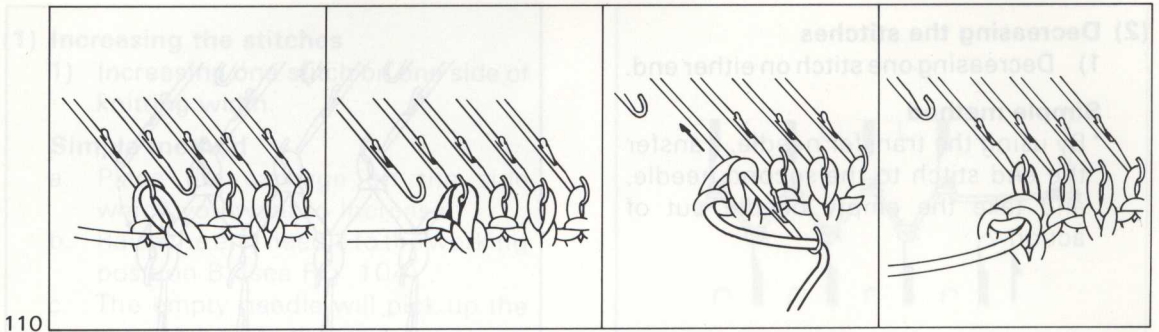

110

c. By using the transfer tool decrease the stitches in the same way as you do in the single bed.

* In other kinds of rib's case decrease in the same way.

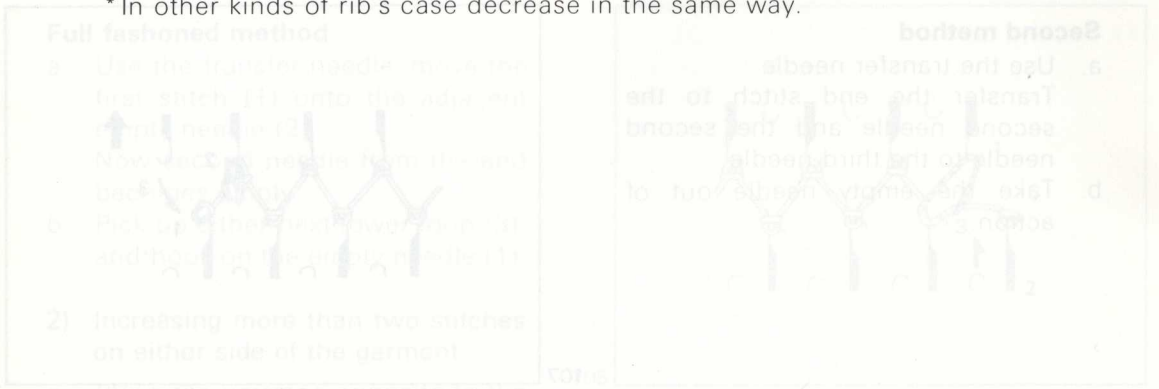

107

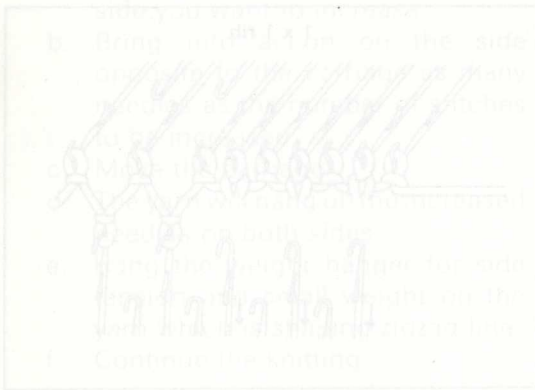

108

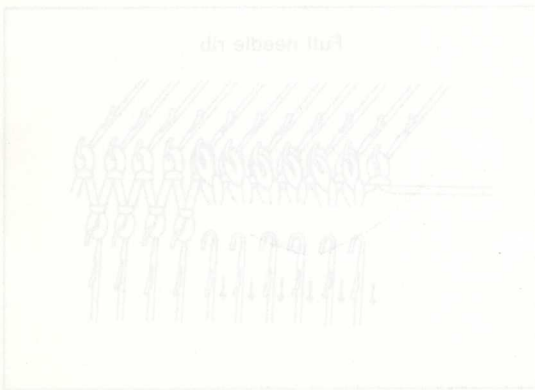

109

(3) How to shape the neck line

- 1) Knit up to the bottom of the neck opening, then, bring the needles for parts ② and ③ forward to position E of KH and KR needle bed.
- 2) By using the cast-on thread, make the stitch by hand and return the needles to position A (non working position).
- 3) Knit the part ①.
For the shoulder (b), decrease the stitch(es) according to the design of the garment.
- 4) Return the stitches for part ② by pulling the cast-on thread (unravel one row which is knitted with cast-on thread).
Knit with wast yarn and cast off.
- 5) Return the stitches for part ③ after pulling the cast-on thread, knit the part ③.

111

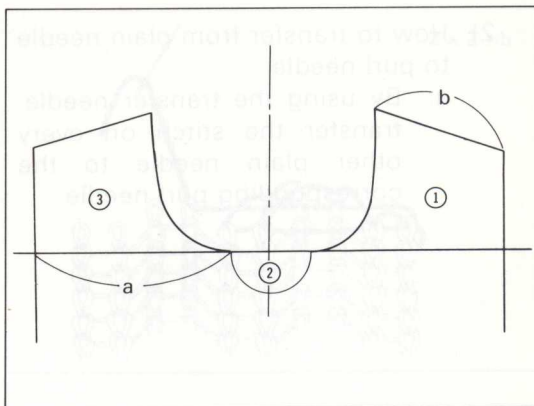

112

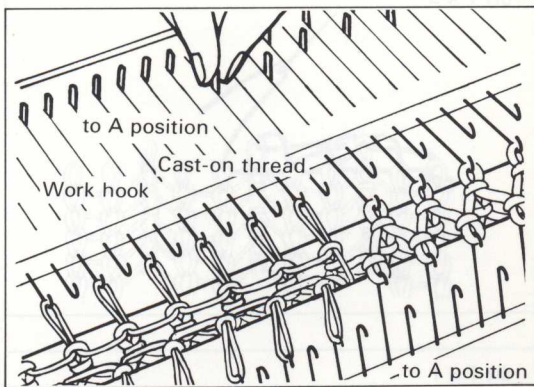

(4) How to transfer the stitches

- 1) How to transfer from purl needle to plain needle.
 - a. Raise the plain needle from position A to B, and open the latch.
 - b. By using the transfer needle, transfer the stitch on the purl needle to the empty plain needle.

113

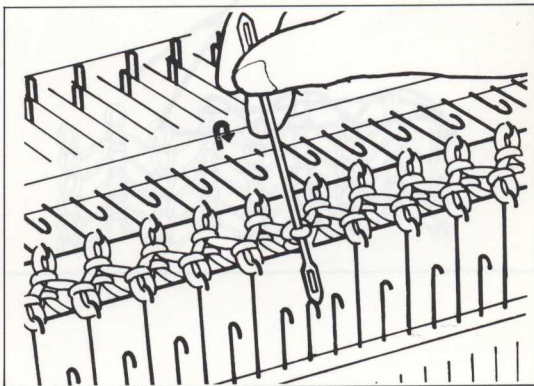

114

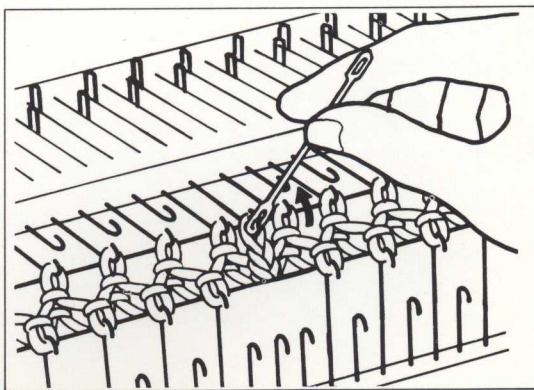

2) How to transfer from plain needle to purl needle.

- a. By using the transfer needle, transfer the stitch on every other plain needle to the corresponding purl needle.

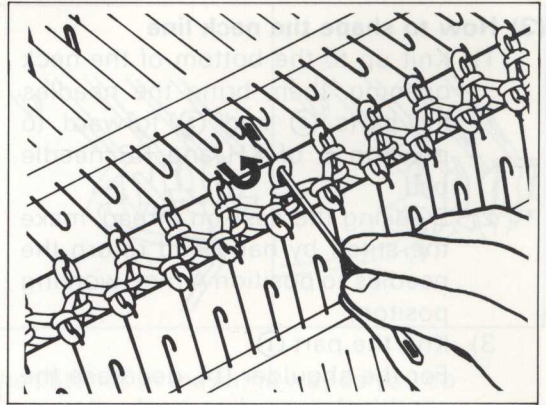

115

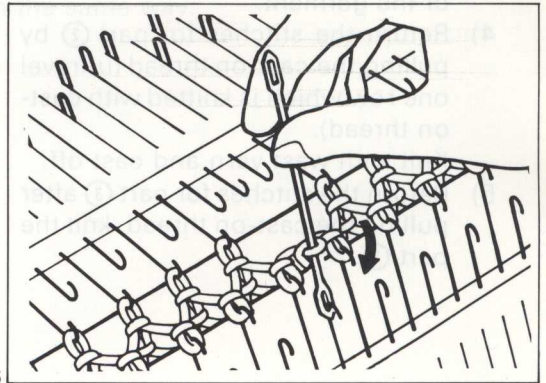

116

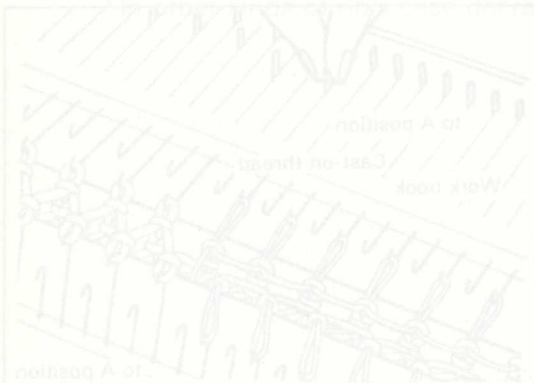

117



118



119

(A) How to transfer the stitches
 1) How to transfer from purl needles to plain needles.
 a. Raise the plain needle from position A to B and open the latch.
 b. By using the transfer needle, transfer the stitch on the purl needle to the empty plain needle.

(5) Binding off and finished edge of rib knitting

BINDING

*This method is used for binding up the stitches of the last row by using the yarn of rib knitting. Binding up is the same as selvedge.

When you finish rib knitting, knit one or three rows of circular knitting, then bind the last row by using the tapestry needle as shown in the figures.

The length of the yarn for binding is 3 times the width of knitting.

117

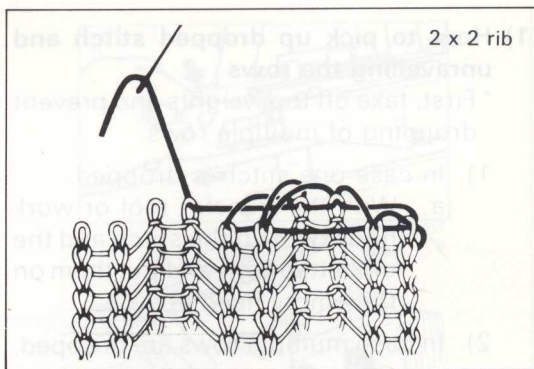

118

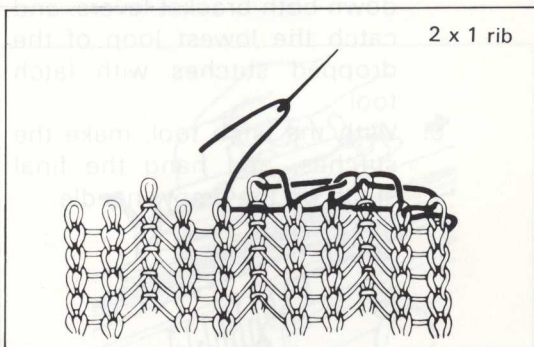

119

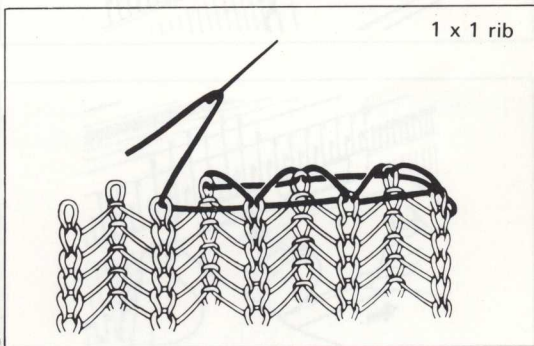

XVII. USEFUL HINTS

(1) How to pick up dropped stitch and unravelling the rows

* First, take off the weights and prevent dropping of multiple rows.

- 1) In case one stitch is dropped.
 - a. With the transfer tool or work hook pick up the stitch and the unknitted yarn and put them on the empty needle.
- 2) In case multiple rows are dropped.
 - a. Open the gate by pushing down both bracket levers, and catch the lowest loop of the dropped stitches with latch tool.
 - b. With the latch tool, make the stitches, and hang the final stitch on the empty needle.

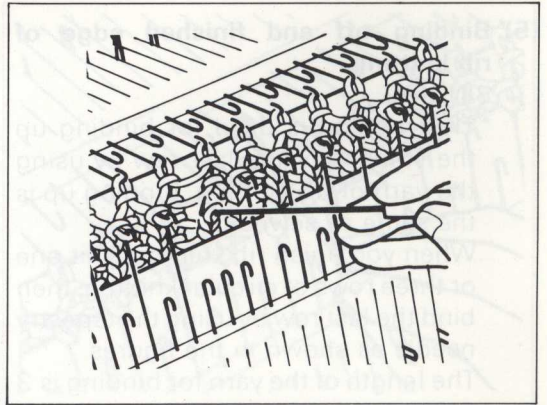

120

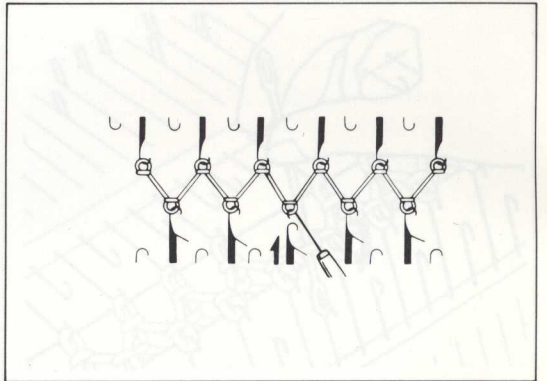

121

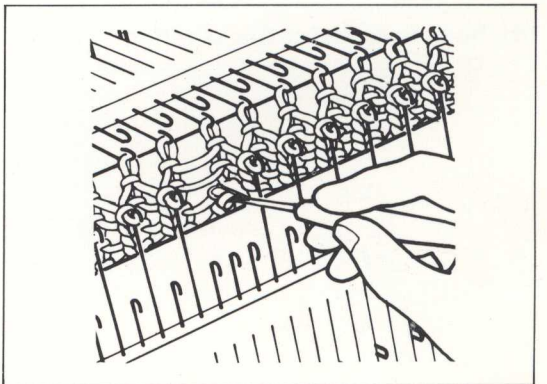

122

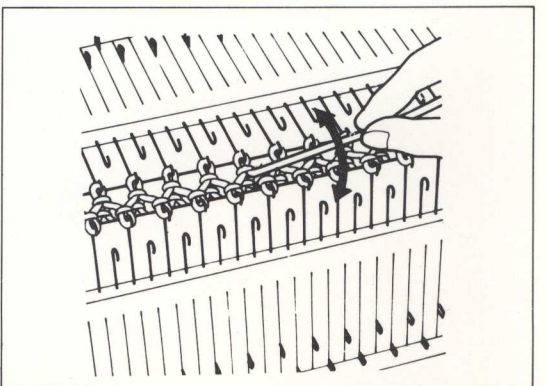

123

Unravelling the rows

* If you have knitted more than necessary, do not remove the work from the knitter and ribber. Simply unravel one or several rows by doing the following. Pull the yarn slightly, drawing it out of the stitches.

The stitches of the previous row will slip into the hook of the needles automatically as the yarn is raised in an upward movement towards the needle bed.

(2) If the carriage should jam ...

How to use the knitter as a single bed with the ribber attached

1) IF THE CARRIAGE SHOULD JAM

- a. Remove the presser on the side which the carriage is commencing from the connecting arm and remove the connecting arm from the carriage, then, replace the KH carriage on the side which you started this row by lifting the front side of KH carriage.
- b. Keeping the front foot of KR carriage off the front rail, replace the KR carriage at the same side of KH carriage.
- c. Connect both carriages with connecting arm and set the presser.
- d. Set the needles in position B of each bed. If the stitch is on the stem of the needle return it into the hook by using the transfer needle.
- e. Unravel the last row.
- f. Continue the knitting.

124

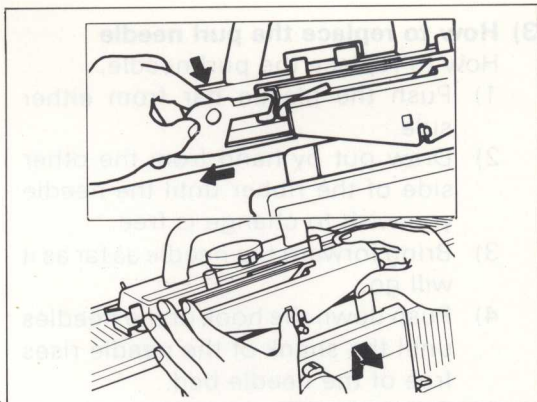

125

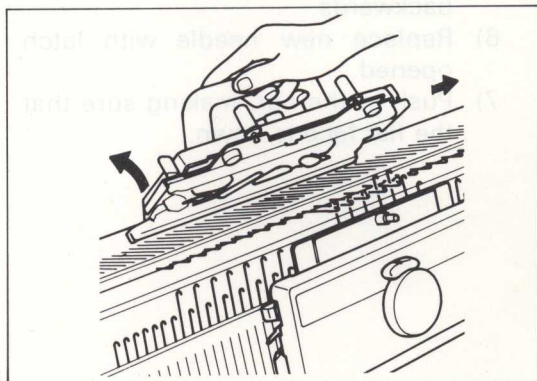

126

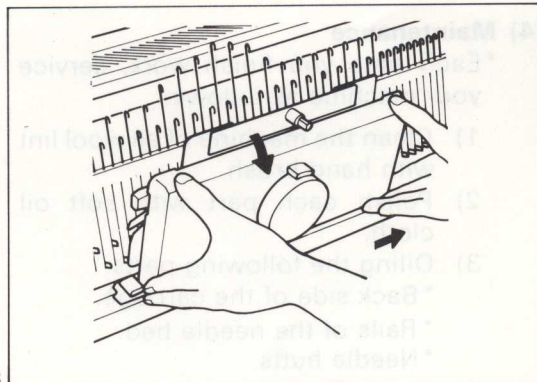

2) How to use the knitter as a single bed

- a. disconnect the carriage.
- b. Push down both bracket levers of the ribber and the ribber will come down one step.
- c. Take off the connecting arm from the KH carriage, and convert it to the sinker plate assembly of knitting machine.
- d. The knitter can be used as a single bed.

127

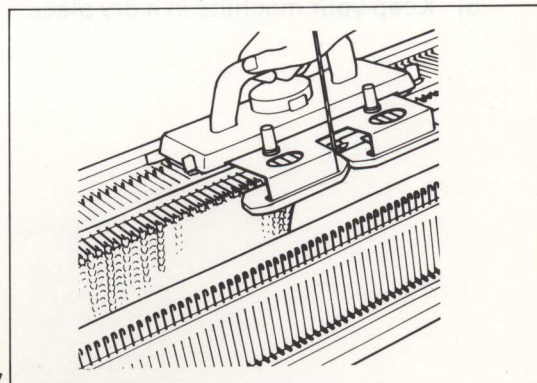

* Remove the Extension racks and the Needle stoppers.

(3) How to replace the purl needle

How to replace the purl needle.

- 1) Push the plastic bar from either side.
- 2) Draw out by hand from the other side of the ribber until the needle you wish to change is free.
- 3) Bring forward the needle as far as it will go.
- 4) Push down the hook of the needles until the shank of the needle rises free of the needle bed.
- 5) Grasp the shank and draw it out backwards.
- 6) Replace new needle with latch opened.
- 7) Push in the bar, making sure that the flat face is down.

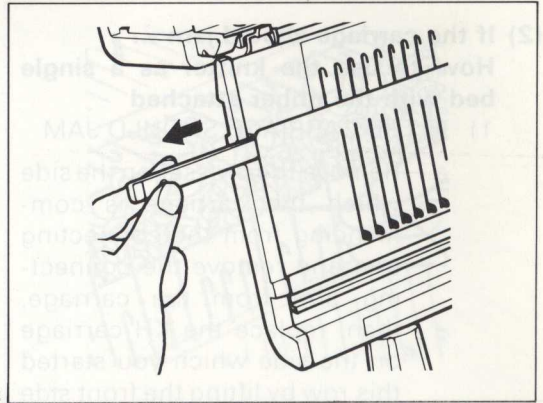

128

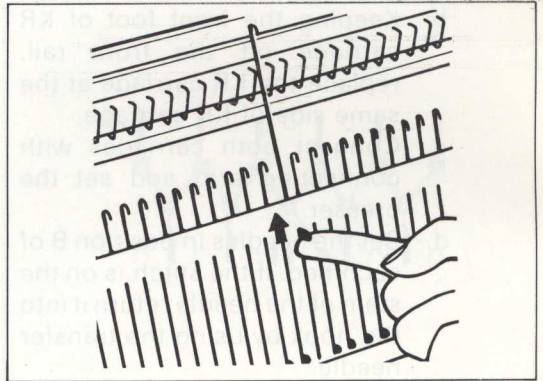

129

(4) Maintenance

*Each time you finish work, service your machine as follows:

- 1) Clean the machine of all wool lint with hand brush.
- 2) Polish each part with soft oil cloth.
- 3) Oiling the following parts.
 - * Back side of the carriage.
 - * Rails of the needle bed.
 - * Needle butts.
- 4) Wipe off stained oil.
- 5) Keep your machine in a dry place.

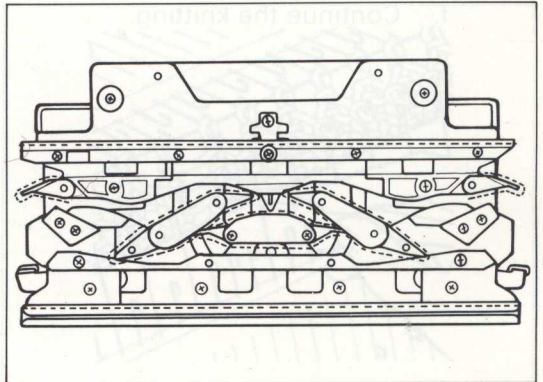

130

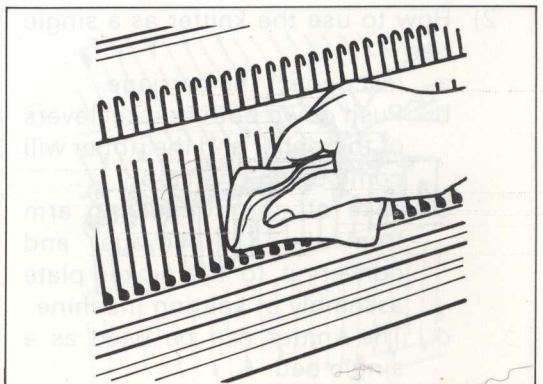

131



