

stitchin' time

Vol5 No5

25p



Jones/brother

contents

Ladies Sweater with Lace Yolk	3-4
Girl's Slip Over	6-7
Boy's V-Neck Sweater	7-8
Man's Zip Fronted Jacket	8-9
Ladies Cardigan Coat	10-11
Man's Long-Line Cardigan	12-14
Girl's Skirt and Jumper	14-15
Toddler's Jersey, Trews and Hat	16-17
His 'n' Hers Matching Waistcoats	17-19
You Write	20-21
Triangular Shawl with Fringe	21
Man's V-Neck Cardigan	22-23
Soft Toys	23-24
Mock Rib Polo Neck Sweater	25
Man's Cable Sweater	26
Boy's Sleeveless Pullover	27-28
Kiddies Jumper and Overalls	28-29
Children's Matching Sweaters	30
Cable Polo Neck Jumper	31-32
Action Man Outfit	32
Lace Tablecloth	33-34
Rainbow Polo Neck Jumper	35

broadly speaking

Here is the Christmas issue with something for everyone. The series of designs produced by young designers is scheduled for the first issue next year. In this issue we are using the remainder of the assorted designs received in the last few months, these new designs will be, we hope, simpler to follow because we are printing them more in a chart form than in a long worded form. Initially, both forms will be printed side by side so that everyone should be able to understand.

It seems strange that whenever we revive our letters page, the flow of letters seems to dry up. So come on ladies! Put pen to paper and let's have your ideas, comments and funny or odd stories about knitting machines.

As forecast in our previous issue, recent costs have at last forced us to raise the price for the five issues from £1.25 to £1.50. We do this with regret, but feel that as we have withheld many increased costs for the past eighteen months, and increased the number of patterns per issue, you will still feel that our magazine represents extremely good value for money, and gives you patterns at a cost of just about 1p per pattern. This increase will not affect you, of course, until your subscription is due for renewal!

In an earlier 'Broadly Speaking' we announced an index we were compiling of ladies who knitted, mentioning that we were often contacted by designers who required knitters. Some ladies seem to have misunderstood us and assumed that we could give details of the work supply and the rates of pay. This, however, we cannot do, as we merely pass a list of names and addresses to any designers who raise this query with us. These designers usually require knitters near their home address. This means that some readers living in isolated areas will not be contacted by the designers. Some designers recently have said that they are prepared to deal with people living at a distance providing there is a small group controlled preferably by one lady, and again, for preference, using the model 800 as their machine. If any readers are in such a group I will forward their names immediately to these designers who will then contact them.

The staff of Jones would like to take this opportunity of wishing all our readers a very happy Christmas and a prosperous new year!

N.B. CHARTS SUBMITTED BY DESIGNERS VARY DEPENDING ON WHICH MACHINE THE DESIGNER HAS USED. MOST PATTERNS USING EIGHT BUTTONS CAN BE DONE ON EITHER THE 588 OR THE 585. THE DIFFERENCES ARE

588	585
REVERSE LEVER+	REVERSE DIAL A
REVERSE LEVER-	REVERSE DIAL B

SUBSCRIPTION RATES FOR U.S.A. AND CANADIAN MEMBERS \$6.00.

These rates include postage.

ladies sweater with lace yolk

Materials

13 (14, 15, 16, 17) ozs. Lister Lavenda Crisp Crepe 4 ply.

Measurements

To fit bust sizes 32 (34, 36, 38, 40) ins.
Length to shoulder 24 (24½, 24¾, 24¾, 25) ins.

Sleeve seam 17 ins. (Adjustable).

Tension

T7. 15 sts. and 21 rows to 2 ins. st.st.

T6. 15 sts. and 24 rows to 2 ins. lace st.

Abbreviations

K., knit; sts., stitches; inc., increase; dec., decrease; foll., following; alt., alternate; rem., remaining; beg., beginning; trans., transfer; T., tension; 000., set row counter to 000; M.B., main bed.

BACK

Ribbers Cast on 127 (135, 143, 151, 159) sts. as 1 x 1 rib. T5/5. K. 24 rows. Trans. ribber sts. to M.B.

Single machines With waste wool cast on 64 (68, 72, 76, 80) sts. over alt. needles K. a few rows. Change to main wool. T5. K. 47 rows. Make hem and K. the row. 127 (135, 143, 151, 159) sts.

All machines 000. T7. K. 4 rows. Dec. 1 st. each end of next and foll. 7th row 11 times in all 105 (113, 121, 129, 137) sts. K. straight to 90 rows. Inc. 1 st. each end of next and foll. 8th row 7 times in all. 119 (127, 135, 143, 151) sts. K. straight to 158 rows*.

Shape Armhole

000. Cast off 6 sts. at beg. of next 2 rows. Dec. 1 st. each end of next and foll. rows until 89 (95, 101, 107, 113) sts. rem. K. straight to 72 (74, 76, 78, 82) rows.

Shape Shoulders

Cast off 5 (5, 6, 6, 6) sts. at beg. of next 8 rows. 4 (6, 4, 6, 8) sts. on foll. 2 rows. Slip rem. 41 (43, 45, 47, 49) sts. onto a knitting pin.

FRONT

K. as Back to *

Shape Armholes

000. T6. Follow lace chart. Cast off 6 sts. at beg. of next 2 rows. Dec. 1 st. at each end of next and foll. rows until 89 (95, 101, 107, 113) sts. rem. K. straight to 50 (52, 54, 56, 58) rows.

Shape Neck

Slip 55 (58, 62, 65, 68) sts. at left onto a knitting needle. Work on right side first. K. 1 row. Dec. 1 st. at beg. (neck edge) of next and foll. alt. rows until 24 (26, 28, 30, 32) sts. rem. K. straight to 82 (84, 86, 88, 92) rows have been worked.

Shape Shoulder

Cast off 5 (5, 6, 6, 6) sts. at beg. of next and foll. alt. rows until 4 (6, 4, 6, 8) sts. rem. K. 1 row. Cast off. Leave centre 21 (21, 23, 23, 23) sts. on needle. Return rem. 34 (37, 39, 42, 45) sts. to machine. Take care to return on correct needles to follow lace pattern. K. as right side reversing all shapings.

SLEEVES

Ribbers Cast on 51 (55, 59, 63, 67) sts. as 1 x 1 rib. T4/4. K. 24 rows. Trans. ribber sts. to M.B.

Single machines With waste wool cast on 26 (28, 30, 32, 34) sts. over alt. needles. K.





What do you think his wife's getting for Christmas?

If you were Father Christmas and could give the best-of-all present to the girl of your heart, what would make her eyes light up as she tore back the shining wrapping paper on Christmas morning?

What else but a new Jones Sewing Machine?

Doesn't matter whether your girl's a housewife, home dressmaker, student or dress designer, there's a Jones Sewing Machine just right for her. With a wide range to choose from, just select the machine that best suits *her* needs and *your* pocket.

Value for money – that's Jones. Whether you buy a straight stitch machine for around £20 or a semi-automatic that masterfully stretch stitches all those man-made fibres at around £60, you'll know you've bought a present that will last her a lifetime. And you'll know you couldn't have found better value. Anywhere.

No two best girls are alike – that's why there's a wide range of Jones machines to choose from!

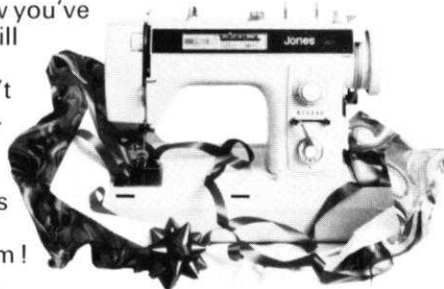

Jones the best present for your best girl.

girls slip over



Materials

3 (4, 5, 5) ozs. 4 ply wool. Main Colour—M.C. 2 (2, 2, 3) ozs. 4 ply wool. Second Colour—S.C. 1 (1, 2, 2) ozs. 4 ply wool. Third Colour—T.C. Plus odd ounce for waste knitting.

Measurements

28 (30, 32, 34) ins. chest/bust.
Length from shoulder 16 (18, 18, 20) ins.

Tension

T10. 6 sts. and 8 rows to 1 in. (slightly stretched).

Abbreviations

St(s), stitch(es); beg., beginning; ins., inches; dec., decrease; foll., following; 000., set row counter at 000.

BACK

Using waste yarn bring 84 (92, 96, 104) needles into working position pushing back every 3rd needle for 2 x 1 rib. Work approx. 10 rows. Change to M.C. Tension two sizes tighter. Work 20 rows. Work 2 rows loosely for fold. Work 20 rows. Make a hem by placing the first loops of M.C. onto the empty needles, 2 onto each. 000. Change back to main tension. Work 4 rows on all needles. Now begin stripe pattern as follows: *** 2 rows T.C. 4 rows S.C. 4 rows M.C. ***. Work from *** to *** until 72 (80, 80, 88) rows worked.

Shape Armholes (keeping in stripe pattern)

Cast off 9 (7, 9, 7) sts. at beg. of next 2 rows **. Now dec. 1 st. at each end of next and every foll. alternate row until 44 (56, 56, 58) sts. remain.

Shape Back Neck (keeping in stripe pattern)

Next row dec. 1 st. pattern 11 (17, 17, 23) sts. Push remaining 32 (38, 38, 44) sts. into D position. H.C.L.'s buttons on III. Now keeping armhole edge straight dec. 1 st. at neck edge on next and every foll. row until

mans zip fronted jacket

Materials

9 (10, 11, 12) ozs. Hayfield Beaulon 4 ply.

Measurements

To fit chest sizes 24 (26, 28, 30) ins.
Length to Back neck 16 (18, 20, 22) ins.
Sleeve seam 12 (13½, 15, 16½) ins.

Tension

T6. 15 sts. and 30 rows to 2 ins.

Abbreviations

K., knit; sts., stitches; inc., increase; dec., decrease; alt., alternate; beg., beginning; tog., together; foll., following; rem., remaining; trans., transfer; H.C.L.'s., holding cam levers; 000., set row counter to 000; T., tension; M.B., main bed.

Notes

Hang-on casting on comb. Use side weights. Either side may be used as right side of garment.

BACK

Ribbers Cast on 96 (104, 112, 120) sts. as 1 x 1 rib. T4/4. K. 14 rows. Trans. ribber sts. to M.B.

Single machines With waste wool cast on 48 (52, 56, 60) sts. over alt. needles. K. a few rows. Change to main wool. T4. K. 27 rows. Make a hem. K. the row. Inc. 1 st. on right hand side 96 (104, 112, 120) sts.

All machines 000. T6. Set machine for Tuck pattern. K. 120 (142, 166, 188) rows. (Adjust length here if required.)*

Shape Raglan

000. Cast off 4 sts. at beg. of next 2 rows. Dec. 1 st. each end of next and foll. 4th row. 22 (23, 24) times in all. 44 (50, 58, 64) sts. then on every alt. row until 34 (36, 38, 40) sts. rem. K. 1 row st.st.

BACK NECKBAND

Ribbers Trans. alt. sts. to ribber. T4/4. K. 10 rows. T10/8. K. 1 row. Chain cast off.

Single machines Trans. alt. sts. to adjacent needles, return empty needles to A pos. T4. K. 20 rows. Cast off loosely making chain over empty needles.

FRONT

K. as Back to *.

Shape Neck and Raglan

000. Push 48 (52, 56, 60) sts. at left to E pos. H.C.L.'s II. K. right side first. Cast off 4 sts. at beg. of next row. K. 1 row. Dec. 1

st. at neck edge of next and foll. 6th row 15 (16, 17, 18) times in all at the same time dec. 1 st. at raglan edge on next and foll. 4th row 22 (23, 24) times, then on every alt. row until 2 sts. rem. K. 1 row. Cast off. H.C.L. I. Return needles to B pos. by hand. K. to match right side reversing all shapings.

SLEEVES

Ribbers Cast on 50 (52, 54, 56) sts. as 1 x 1 rib. K. as Back rib.

Single machines With waste wool cast on 25 (26, 27, 28) sts. over alt. needles. K. as Back welt. Inc. 1 st. on right hand side 50 (52, 54, 56) sts.

All machines 000. T6. Follow Tuck pattern. K. 16 rows. Inc. 1 st. each end of next and foll. 12th (12th, 14th, 14th) row 11 (12, 13, 14) times in all. 72 (76, 80, 84) sts. K. straight to 158 (180, 202, 226) rows. (Adjust length here if required.)

Shape Raglan

000. Cast off 4 sts. at beg. of next 2 rows. Dec. 1 st. each end of next and foll. 4th row 23 (25, 26, 28) times in all. 18 (18, 20, 20) sts. then on every alt. row until 12 sts. rem. K. 1 row in st.st. Slip sts. onto a pin.

NECKBAND

With wrong side facing, pick up and place on machine 52 (56, 60, 64) sts. from down right side of neck 64 (68, 72, 76) sts. T7. K. 1 row.

Ribbers Leaving 2 sts. at Vee on M.B. trans. next and alt. sts. to ribber. T4/4. K. 1 row. Dec. 1 st. (using the 2-st. trans. tool) at Vee on next 9 rows. T10/8. K. 1 row. Trans. ribber sts. to M.B. Chain cast off. K. left side to match.

Single machines Trans. alt. sts. to adjacent needles. Return empty needles to A pos. T4. K. 10 rows, dec. 1 st. at Vee on every alt. row. K. 1 row. K. 9 rows, inc. 1 st. at Vee on next and alt. rows. Cast off loosely, making chain over empty needles. K. left side to match.

MAKE UP

Pin out and press with a cool iron over a dry cloth. Join raglan, side and sleeve seams. Join mitre in centre of neckband.

Single machines Turn neckband to inside and slip st. in place. Press seams.

Materials

16 (17, 18, 20, 21) 50 grms. Balls M. Patons Double Knitting wool. 1 50 grms. ball each contrast A and B. 1 open ended zip to fit front.

Measurements

To fit chest 34 (36, 38, 40, 42) ins.
Length to shoulder 26½ (26¾, 27, 27¼, 27½) ins.

Sleeve length 19 ins.

Tension

T10. 12 sts. and 30 rows to 2 ins.

Abbreviations

K., knit; sts., stitches; inc., increase; dec., decrease; beg., beginning; alt., alternate; foll., following; rem., remaining; T., tension; 000., set row counter to 000; M.B., main bed.

Notes

Machines without ribbing attachment. K. the welts and collar by hand, or alternatively K. in st.st. and drop alt. sts. and crochet up as rib.

BACK

With M. wool cast on 112 (118, 124, 130, 136) sts. as 1 x 1 rib *. T7/7. K. 5 rows M. 4 rows A. 2 rows M. 4 rows B. 2 rows M. 4 rows A. 3 rows M. 24 rows. Trans. ribber sts. to M.B. *. 000. T10. Follow pattern chart. K. 240 rows.

Shape Armholes

000. Cast off 4 sts. at beg. of next 2 rows. Dec. 1 st. each end of next and foll. alt. rows 9 (10, 11, 12, 13) times. 86 (90, 94, 98, 102) sts. rem. K. straight to 120 (124, 128, 132, 136) rows.

Shape Shoulders

Cast off 3 (3, 4, 4, 4) at beg. of next 12 rows. 7 (8, 3, 4, 5) sts. on foll. 2 rows. Cast off rem. 36 (38, 40, 42, 44) sts.

LEFT FRONT

With M. Cast on 56 (60, 62, 66, 68) sts. as 1 x 1 rib. K. as Back from * to *. 000. T10. Follow pattern chart K. 240 rows.

Shape Armhole

000. Cast off 4 sts. at beg. of next row. K. 1 row. Dec. 1 st. at beg. of next and foll. alt. rows 9 (10, 11, 12, 13) times. 43 (46, 47, 50, 51) sts. rem. K. straight to 87 (89, 91, 93, 95) rows.

Shape Neck

Cast off 9 (10, 10, 11, 11) sts. at beg. of next row. K. 1 row. Dec. 1 st. at beg. of next and foll. alt. rows until 25 (26, 27, 28, 29) sts. rem. K. straight to 120 (124, 128, 132, 136) rows.

Shape Shoulder

Cast off 3 (3, 4, 4, 4) sts. at beg. of next and foll. alt. rows until 7 (8, 3, 4, 5) sts. rem. K. 1 row. Cast off.

RIGHT FRONT

K. as Left Front reversing all shapings.

SLEEVES

With M cast on 52 (54, 58, 60, 64) sts. as 1 x 1 rib. K. as Back from * to *. 000. T10. Foll. pattern chart. K. 10 rows. Inc. 1 st. each end of next and foll. 14th (13th, 12th, 11th, 11th) row. 15 (16, 17, 18, 19) times in all 82 (86, 92, 96, 102) sts. K. straight to 248 rows. (Adjust length here if required.)

Shape Top

000. Cast off 4 sts. at beg. of next 2 rows. Dec. 1 st. each end of next and foll. alt. rows 8 (8, 10, 12, 15) times, then on every

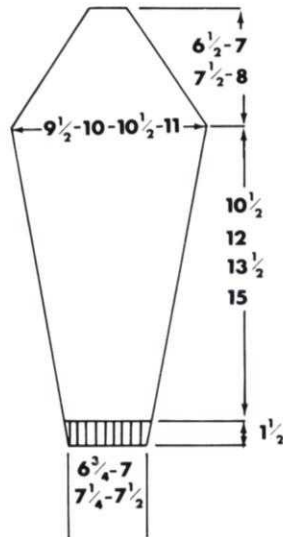
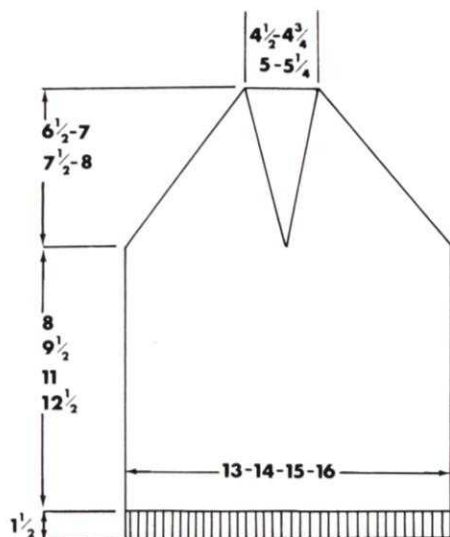

ladies cardigan coat

Materials

18 (19, 20, 21, 22) 50 grms. balls Patons Double Knitting.

Measurements

To fit 32 (34, 36, 38, 40) ins. bust.
34 (36, 38, 40, 42) ins. at underarm.
26 ins. length. (Adjustable.)
18 ins. sleeve seam.

Tension

6½ sts. and 8 rows to 1 in. on T10 (stocking stitch).

7 sts. and 8 rows to 1 in. on T10 (cable pattern).

Abbreviations

COBH., cast on by hand over every N; st(s), stitch(es); T., tension; K., knit; COL(R), carriage on left or right; MDE., make double hem by placing each loop at cast on edge onto N. in B pos; 000., set row counter to 000; dec., decrease; foll., following; fin., finishing; beg., beginning; rem., remaining; cont., continue; alt., alternate; trans., transfer(ring); N., needles; pos., position; patt., pattern; (adjust), adjust length at this stage if desired.

Note

K. with loose yarn tension unit throughout. On the cable patt. count all empty N. as sts. Pull cable N. forward to E pos. after twisting them.

CABLE PATTERN

* K. 4 rows. To form cables on each set of 6 sts. and using 3 sts. ends of trans. tools, place left 3 sts. onto one tool., place right 3 sts. onto other tool and place these right 3 sts. onto the empty 3 left N., place left 3 sts. onto right 3 empty N. K. 4 rows. Rep. from * throughout.

BACK

COBH. 126 (132, 138, 144, 150) sts. * T7. K. 10 rows. T10. K. 1 row for foldline. T7. K. 10 rows. COL. MDE. ** T10. K. 1 row. COR. 000. * Dec. 1 st. each end of every foll. 12th row 6 times to 114 (120, 126, 132, 138) sts. fin. COR. (Adjust.) 000. K. 40 rows.

Shape Armholes

Cast off 8 (9, 10, 11, 12) sts. at beg. of the next 2 rows. 98 (102, 106, 110, 114) sts. 000. K. 64 rows fin. COR.

Shape Shoulder

Cast off 7 sts. at beg. of the next 8 rows, cast off 4 (5, 6, 7, 8) sts. at beg. of the next 2 rows. Cast off rem. 34 (36, 38, 40, 42) sts.

RIGHT FRONT

COBH. 69 (72, 75, 78, 81) sts. Rep. * to ** as on back fin. COL. On left edge cast on 7 sts., T10. K. 1 row. COR. 000. 76 (79, 82, 85, 88) sts. Place left holding cam lever to III, the right to I. On left edge, to form foldline, push the 7th N. to E pos. K. 7 rows. Rep. these 2 rows, at the same time dec. 1 st. on the right edge on the 12th row and at this same edge every foll. 12th row 5 times more to 70 (73, 76, 79, 82) sts. fin. COR. Thread up and take off work the left 13 sts. 57 (60, 63, 66, 69) sts.

Shape Neck

000. Keeping right edge straight, dec. 1 st. on the left edge on the next and then every foll. 6th (6th, 5th, 5th, 5th) rows to 40 rows fin. COR.

Shape Armhole



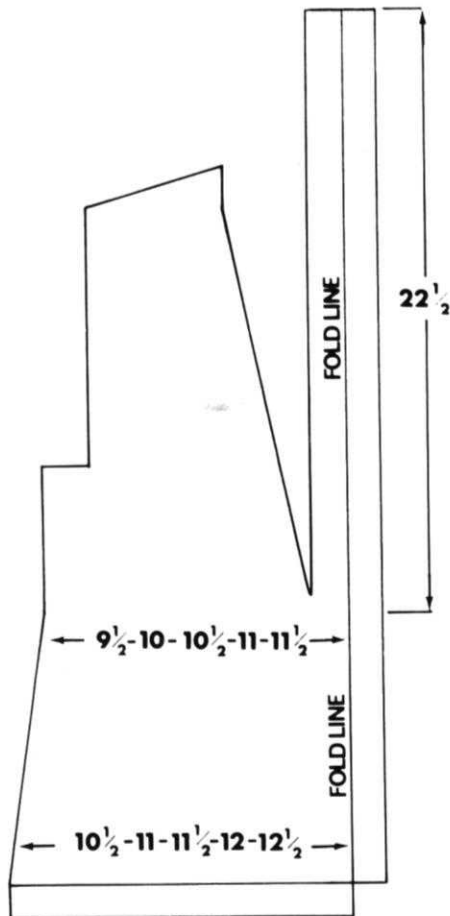
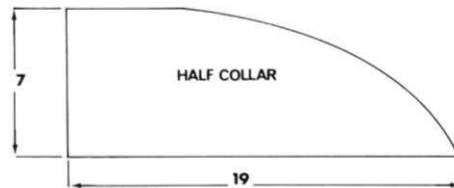
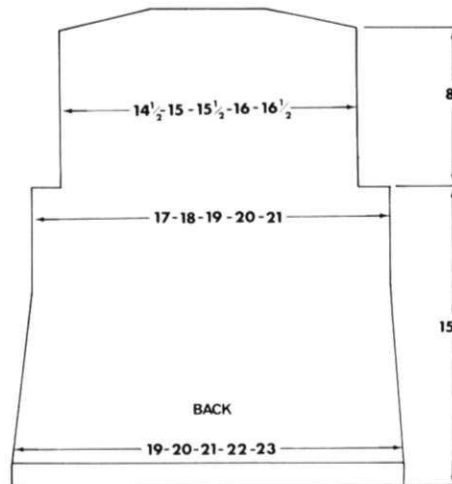
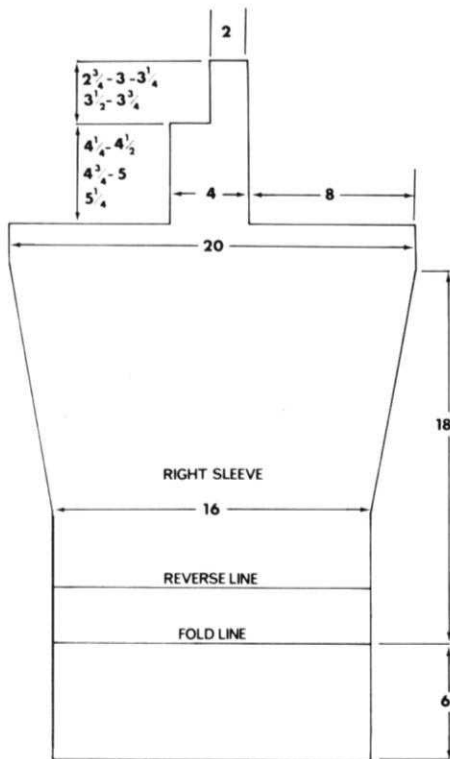

Cast off 8 (9, 10, 11, 12) sts. on right edge. Cont., dec. on neck to 32 (33, 34, 35, 36) sts. Cont. straight to 104 rows fin. COR.

Shape Shoulder

Cast off 7 sts. at beg. of the next row and at this same edge every foll. alt. row 3 times more fin. COR. Cast off rem. 4 (5, 6, 7, 8) sts. K. left front to match reversing shapings.

RIGHT SLEEVE

T10. COBH. centrally 122 sts. ** K. 1 row. COL. To set N. for cable patt. and working to the right of centre O, trans. the 3rd st. to the 2nd N., 10th st. to 11th N., 15th st. to 14th N., 22nd st. to 23rd N., cont. in this way to right edge, trans. N. into groups of 6 and 4 sts. Push all empty N. to A (none working) pos. Trans. sts. to left of centre O the same. K. 1 row. COR. 000. **.

Cont. in patt. for 72 rows. With scrap yarn K. a few rows and take work off machine. Reverse work and place back onto same N. as before. Cont. in patt. for 24 rows. 000. Inc. 1 st. each end of every foll. 8th row to 146 sts., working extra sts. into the patt. Cont. straight to 112 rows. fin. COR. (Adjust.)

Shape Saddle Strap

Cast off 59 sts. on each edge. Bring to B pos. 1 N. on each edge. (30 N.) 000. Cont. straight for 33 (35, 37, 39, 41) rows fin. COL. Cast off 14 sts. on left edge for side neck, K. to end. 000. Cont. straight for 24 (24, 26, 26, 28) rows. Cast off. Work left sleeve to match reversing pos. of side neck and top of saddle strap.

LEFT HALF COLLAR

T10. COBH. centrally 146 sts. Rep. ** to ** as on sleeves. Cont. in patt. at some time casting off 2 sts. at beg. of the next row and at this same edge 11 times more fin. COR.

(122 sts.) Cast off 3 sts. at beg. of the next row and at this same edge 5 times more fin. COR. (104 sts.) Cast off 8 sts. at beg. of the next row and at this same edge 7 times more fin. COR. (40 sts.) Cast off. Work right half collar to match reversing shapings.

POCKETS

T10. COBH. centrally 46 sts. Rep. ** to ** as on sleeves. Cont. in patt. for 48 rows. Cast off.

COLLAR EDGINGS

With right side of work facing machine place the 13 sts. onto N. T10. Place holding cam levers as before. Cont., pushing forward the same middle N. for foldline every alt. row and K. to 196 rows. Cast off.

SLEEVE AND POCKETS EDGINGS

T10. COBH. 13 sts. K. 2 rows. Place holding cam levers as before. Push forward the centre N. every alt. row and K. to 132 rows for sleeves, 52 rows for pockets. Cast off.

BELT

T10. COBH. 33 sts. K. 2 rows. Place holding cam levers as before. From each edge push forward the 9th N. for foldline. K. to 400 (416, 432, 448, 464) rows. Cast off.

TO MAKE UP

Press all pieces. Join saddle cast off ends, sew long saddle edge to back neck and shoulders. Sew short saddle edge to front shoulders. Sew long cast off edge of sleeve into straight edges of armholes, and the armhole cast off edges to part of sleeve seam. Join side and sleeve seams. Join collar back seam, sew shaped collar edge to neck edge. Join ends of collar edging and sew to collar cast on edge. Sew down facings on front edges. Sew edgings to sleeves and pocket tops. Sew on pockets. Sew belt seam and ends. Press belt and all seams. Make loops on side seam to carry belt. Fold back cuff and secure to sleeve seam.

back
numbers

We have a limited supply of back numbers of *Stitchin' time*. Issues available are:

Vol. 4 No. 2
Vol. 4 No. 3
Vol. 5 No. 2
Vol. 5 No. 3

Each issue costs 25p, postage free, from:
Stitchin' time Back Numbers
Jones Sewing Machine Co.
Brittania House
964 High Road
Finchley
London N12

mans long-line cardigans

Materials

19 (20, 22, 23, 25) ozs. Patons Purple Heather 4 ply. 1 oz. 4 ply in contrast. Allow 2 ozs. extra for Cardigan with collar. 5 buttons for V-neck cardigan. 7 buttons for cardigan with collar.

Measurements

To fit chest sizes 36 (38, 40, 42, 44) ins.

Finished measurements 38 (40, 42, 44, 46) ins.

Length to Back neck $27\frac{1}{2}$ (28, $28\frac{1}{2}$, 29, $29\frac{1}{2}$) ins.

Sleeve seam 19 ins.

Tension

T7. $15\frac{1}{2}$ sts. and 20 rows to 2 ins. after pressing.

Abbreviations

K., knit; sts., stitches; inc., increase; dec., decrease; tog., together; beg., beginning; alt., alternate; rem., remaining; foll., following; H.C.L's., holding cam levers; M.B., main bed; 000., set row counter to 000; T., tension.

Notes

These garments were knitted on a machine with ribbing attachment.

Single machines K. all welts, front bands and collar in st.st. T6. and drop alt. sts. at convenient intervals and crochet up for rib.

Fully fashioning at raglan edges. Trans. 6th st. onto 7th needle, and move end 5 sts. one needle in. **V-neck shaping.** Trans. 2nd st. onto 3rd needle.

V-neck Cardigan

BACK

Cast on 147 (155, 163, 171, 179) sts. as 1 x 1 rib. T5/5. K. 24 rows. Trans. ribber sts. to M.B. 000. T7. K. 150 rows.

Shape Raglan

000. Cast off 4 sts. at beg. of next 2 rows. K. 2 rows. Dec. 1 st. (see notes) at beg. of next and foll. 4th row 5 (4, 4, 3, 3) times, then on every alt. rows until 51 (53, 55, 57, 59) sts. rem. K. 1 row. *

NECKBAND

T6. K. 1 row. Change to contrast wool. K. 4 rows. Change to main wool. K. 1 row. Trans. alt. sts. to ribber. T4/4. K. 11 rows. K. 1 loose row. Trans. ribber sts. to M.B. Chain cast off.

LEFT FRONT

Cast on 68 (72, 76, 80, 84) sts. as 1 x 1 rib. T5/5. K. 24 rows. Trans. ribber sts. to M.B. 000. T7. K. straight until 130 rows have been worked. Mark right side with contrast wool.

Shape Front Neck

Dec. 1 st. (see notes) at right side on next and every foll. 6th row. K. to 149 rows. (150 rows on right front.)

Shape Raglan

000. Continue to dec. at neck edge on every 6th row, **at the same time**, cast off 4 sts. at beg. of next row. K. 3 rows. Dec. 1 st. at beg. of next and foll. 4th row 5 (4, 4, 3, 3) times, then on every alt. row until 10 (9, 9, 8, 8) sts. rem. Keeping neck edge straight, continue raglan dec. until 6 sts. rem. K. 1 row. Dec. 1 st. at neck edge on next and alt. rows until 2 sts. rem. Cast off.

RIGHT FRONT

K. as Left Front reversing all shapings.

SLEEVES





Cast on 69 (73, 77, 81, 85) sts. as 1 x 1 rib. T4/4. K. 24 rows. Trans. alt. sts. to M.B. 000. T7. K. 10 rows. Inc. 1 st. each end of next and foll. 6th row 23 times in all. 115 (119, 123, 127, 131) sts. K. straight to 166 rows. (Adjust length here if required.)

Shape Raglan

000. Cast off 4 sts. at beg. of next 2 rows. K. 2 rows. Dec. 1 st. each end of next and foll. 4th row. 5 (5, 6, 6, 7) times, then every alt. row until 19 sts. rem. K. 1 row. Cast off.

FRONT BANDS

With wrong side facing, pick up and place on machine 120 sts. from left front between marker and lower edge. T6. K. as back neckband, making **buttonholes** after 4th row of rib on needles 8, 36, 64 and 92 from right side. (5th buttonhole is made during finishing.) Now pick up 93 (97, 101, 105, 109) sts. from beg. of neck shaping to top of shoulder and 19 sts. from left sleeve. K. as back neckband, taking care to keep continuity of rib when trans. sts. to ribber. Work right side to match, omitting buttonholes.

MAKE UP

Pin out and press with a warm iron over a damp cloth omitting ribbing. Join raglan, side and sleeve seams. Join front bands at neck shaping leaving small opening on left front for 5th buttonhole. Sew on buttons. Press seams.

CARDIGAN WITH COLLAR

SLEEVES

K. as given for sleeves for V-neck Cardigan.

BACK

K. as V-neck Cardigan to *. Cast off.

LEFT FRONT

K. as V-neck to 50 rows.

POCKET

H.C.L's III. Push 8 (10, 12, 14, 16) at left and 20 (22, 24, 26, 28) sts. at right to E pos. K. on rem. 40 sts. K. 100 rows. Break wool. Take carriage over to right side of work. H.C.L's I. Return row counter to 50. K. straight to 149 rows. (K. 1 row more for Right Front.)

Shape Raglan Edge

000. Cast off 4 sts. at beg. of next row. K. 3 rows. Dec. 1 st. at beg. of next and foll. 4th row, 5 (4, 4, 3, 3) times in all then every foll. alt. row until 37 (38, 39, 40, 41) sts. rem. Carriage at right.

Shape Neck

Cast off 6 (7, 8, 9, 10) sts. at beg. of next row. K. 1 row. Dec. 1 st. at beg. of next and foll. alt. rows 12 times in all, **at the same time** continue to dec. at raglan edge on alt. rows until 6 sts. rem. K. 1 row. Dec. 1 st. at neck edge on next and alt. rows, until 2 sts. rem. Cast off.

RIGHT FRONT

K. as left front omitting pocket and reversing all shapings.

COLLAR

Using main wool cast on 181 (185, 189, 193, 197) sts. as 1 x 1 rib. T5/5. K. 16 rows. T6/6. K. 20 rows. Change to contrast. K. 4 rows. Change to main wool. K. 6 rows. K. 1 loose row. Trans. ribber sts. to M.B. Chain cast off.

FRONT BANDS

With wrong side facing pick up and place

girls skirt and jumper

on machine 186 (188, 192, 194, 198) sts. along left front. T6. K. 1 row. Change to contrast. K. 4 rows. Trans. alt. sts. to ribber. T4/4. Change to main wool. K. 12 rows, making buttonholes after 4th row of rib on 5th needle from each end and spacing remainder evenly between. K. 1 loose row. Trans. ribber sts. to M.B. Chain cast off. K. right front band to match, omitting buttonholes.

POCKET TOPS

With inside of pocket top facing, pick up and place on machine 40 sts. from foldline of pocket top. T7. With contrast wool K. 4 rows. Change to main wool K. 1 row. Trans. alt. sts. to ribber. T5/5. K. 8 rows. T8/8. K. 1 row. Trans. ribber sts. to M.B. Chain cast off.

MAKE UP

Pin out and press with a warm iron over a damp cloth. Join raglan, side and sleeve seams. Sew cast on edge of collar to neck, placing edges at centre of front bands. Sew on buttons. Sew side seams of pocket lining tog. Slip st. edges of pocket tops in place. Press seams.

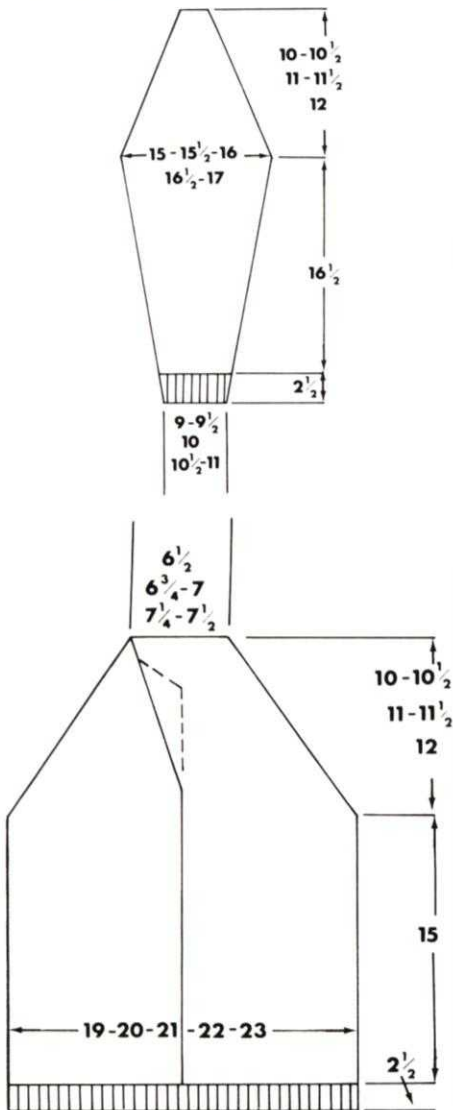

Materials

Jumper

7 (8, 9) ozs. Robin Vogue 4 ply in main A.
1 oz. in contrast B. 4 ins. zip.

Skirt

4 (5, 5) ozs. Robin Vogue 4 ply in main A.
3 (3, 4) ozs. in contrast B. $\frac{1}{4}$ inch wide elastic to fit waist.

Measurements

To fit chest sizes 24 (26, 28) ins.

Jumper

Finished measurements 26 (28, 30) ins.

Length to back neck 14 (16, 18) ins.

Sleeve seam 11 $\frac{1}{2}$ (13, 15 $\frac{1}{2}$) ins.

Skirt

Length 10 (12, 14) ins.

Tension

Pattern stitch

T5. 14 $\frac{1}{2}$ sts. and 32 rows to 2 ins.

Stocking stitch

T7. 15 sts. and 18 $\frac{1}{2}$ rows to 2 ins.

Abbreviations

K., knit; sts., stitches; inc., increase; dec., decrease; alt., alternate; beg., beginning; foll., following; H.C.L.'s., holding cam levers; T., tension; 000., set row counter to 000.

JUMPER

BACK

Bring 97 (105, 113) needles to B position and arrange needles for 2 x 1 mock rib. Using waste wool cast on and K. a few rows. Change to A. T5. K. 31 rows. Make a hem (filling empty needles) and K. the row. 000. T7. K. straight to 74 (84, 102) rows. Adjust length here if required.

Shape Armholes

000. Cast off 4 sts. at beg. of next 2 rows. Dec. 1 st. at each end of next 7 (8, 9) rows. 75 (81, 87) sts. remain *. K. straight to 42 (46, 50) rows.

Shape Shoulders

Cast off 6 sts. at beg. of next 6 rows and 3 (5, 7) sts. on next 2 rows. Slip remaining 33 (35, 37) sts. onto a stitch holder.

FRONT

K. as given for Back to *. K. straight to 26 (28, 30) rows.

Divide for Neck

Using odd length of wool cast off 15 (17, 19) sts. at centre. Push needles at left to E position. H.C.L.'s III. K. the right side first. Dec. 1 st. at neck edge on next 5 rows, then every alt. row until 21 (23, 25) sts. remain. K. straight to 42 (46, 50) rows.

Shape Shoulder

Cast off 6 sts. at beg. of next and alt. rows until 3 (5, 7) sts. remain. K. 1 row. Cast off. H.C.L.'s I. K. left side to match.

SLEEVES

Using A. cast on 51 (53, 55) sts. by hand. T5. K. 10 rows. 000. Foll. chart K. 30 rows. Change to st.st. T7. and A. 000. Inc. 1 st. at each end of next and every foll. 8th (9th, 10th) row 10 (11, 12) times in all. 71 (75, 79) sts. K. straight to 88 (102, 124) rows. Adjust here if required.

Shape Top

000. Cast off 4 sts. at beg. of next 2 rows. Dec. 1 st. at each end of next 5 rows, then every alt. row 7 times. Dec. 1 st. at each end of next 5 (7, 9) rows. Cast off 3 sts. at beg. of next 4 rows. Cast off.

NECKBAND

Join right shoulder seam. Bring 82 (90, 98) needles to B position. With wrong side of work facing and beg. at right, place on machine 33 (35, 37) sts. from back neck. 17 (19, 21) sts. down front neck, 15 (17, 19) sts. across centre front and 17 (19, 21) sts. up front neck. Using A. and T7. K. 1 row. T5. Foll. chart. K. 16 rows. Change to A. and st.st. T6. K. 9 rows. Cast off loosely.

TO MAKE UP

Pin out pieces and press using a hot iron over a damp cloth. Join side, and sleeve seam. Turn neckband to wrong side and slip st. in place. Leaving left shoulder open for 4 ins. join remainder. Sew in zip. Sew in sleeves. Turn hem at cuffs to wrong side and slip st. in place. Press seams.

SKIRT

BACK AND FRONT (Alike)

Using A. cast on 97 (109, 121) sts. by hand. T5. K. 20 rows. 000. K. 2 rows. Foll. chart K. 18 rows. Dec. 1 st. at each end of next and every 14th row 9 (11, 13) times in all. 79 (87, 95) sts. remain. K. straight to 150 (180, 210) rows. Adjust here if required. Continue in A only. Transfer every 3rd st. to adjacent needle and push empty needles to A position. T5. K. 10 rows. Cast off loosely making a chain over empty needles.

STRAPS (two)

Using A cast on 9 sts. by hand. K. 1 row. T5. Foll. chart. K. for desired length. Cast off.

TO MAKE UP

Pin out pieces and press using a hot iron over a damp cloth. Join side seams. Turn 10 rows at lower edge to wrong side and

slip st. in place. Cut elastic to fit waist and join ends. Turn waistband to wrong side over elastic and slip st. in place. Work 1 row of double crochet along sides of straps. Sew straps place to waistband as shown. Press seams.

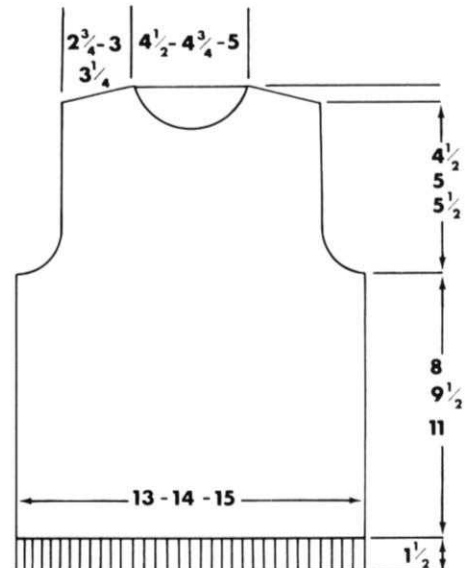
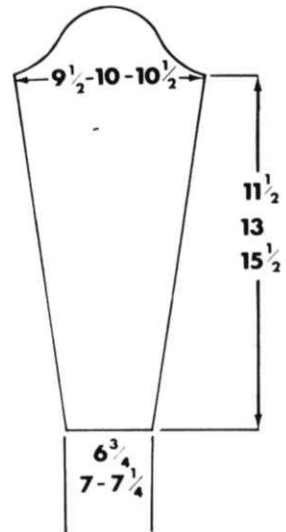
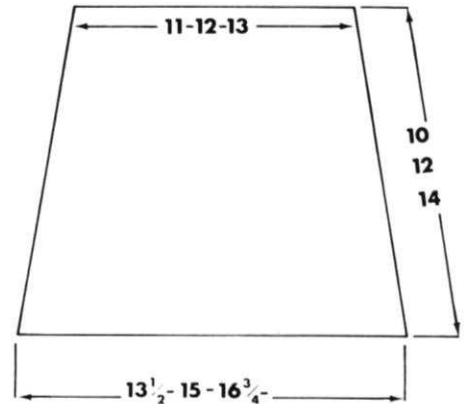

" 3													△	8	8									" I "	→	" "					
B "														7	7									" "	→	" "					
" "														6	6									" "	→	" "					
A 2		\	O			O								5	5	■								" III "	→	3	"				
" 3														4	4									" I "	→	" "					
B "														3	3									" "	→	" "					
" "														2	2									" "	→	" "					
A 2		\		O			O							1	1	■								" III "	→	I	+				
COLOUR	H.C.L.	S.L.	1	2	3	4	5	6	7	8	9	10	11	12	STEPS	STEPS	1	2	3	4	5	6	7	8	L H.C.L.	R H.C.L.	PLAIN	K.C.	S.D.	R.D.	
		K.H. 800 MACHINE												K.H. 588 MACHINE																	

toddlers jersey, trewws and hat



For machines with ribber attachment

Materials

10 (12, 14) 25 gm. balls of Emu Machine Washable Double Knitting in main colour. 4 (4, 5) balls in contrast colour.

Measurements

Jumper To fit chest sizes 18 (20, 22) ins.

Finished measurements 20 (22, 24) ins.

Length to back neck 10 (11, 12) ins.

Sleeve seam $5\frac{1}{2}$ (7, $8\frac{1}{2}$) ins.

Trewws Inside leg $8\frac{1}{2}$ ($10\frac{1}{2}$, 13) ins.

Outside leg 15 ($17\frac{1}{2}$, $20\frac{1}{2}$) ins.

Tension

T10. 13 sts. and 16 rows to 2 ins. stocking st.

Abbreviations

K., knit; inc., increase; sts., stitches; dec., decrease; beg., beginning; alt., alternate; rem., remaining; tog., together; H.C.L's., holding cam levers; 000., set row counter to 000; T., tension; M.B., main bed.

Notes

Fully fashioning at raglan dec. is worked by trans. 3rd st. onto 4th needle, move 2 end sts. 1 needle in.

JERSEY

Work stripes of 6 rows in each colour.

BACK

With main wool case on 64 (70, 76) sts. as 2 x 2 rib T7/7. K. 8 rows. Trans. ribber sts. to M.B. 000. T10. Fglow stripe pattern (see notes) K. 36 (48, 60) rows.

Shape Raglan

000. Cast off 4 sts. at beg. of next 2 rows * Dec. 1 st. (see notes) each end of next and foll. alt. rows until 22 (24, 26) sts. rem. K. 1 row. Slip sts. onto a pin.

FRONT

K. as Back to *. Dec. 1 st. each end of next and foll. alt. rows until 26 (30, 32) rows have been worked.

Shape Neck

Slip centre 10 (12, 12) sts. onto a pin. Push 11 (11, 13) sts. at left to E. pos. H.C.L's III. K. right side first. Continue to dec. at raglan as before, **at the same time** K. 1 row. Dec. 1 st. at neck edge of next and foll. alt. rows until 3 sts. rem. Dec. once more at raglan edge, K. 1 row. Fasten off. H.C.L's I. Join wool at neck edge. K. left side to match, reversing all shapings.

SLEEVES

With main cast on 42 (44, 48) sts. as 2 x 2 rib. T7/7. K. 8 rows. Trans. ribber sts. to M.B. 000. T10. Follow stripe pattern. K. 6 rows. Inc. 1 st. each end of next and foll. 7th (8th, 9th) row, 5 (6, 6) times in all. 52 (56, 60) sts. K. straight to 36 (48, 60) rows.

Shape Raglan

000. Cast off 4 sts. at beg. of next 2 rows. Dec. 1 st. at each end of next and foll. alt. rows until 10 sts. rem. K. 1 row. Slip sts. onto a pin.

NECKBAND

With wrong side facing place on machine 22 (24, 26) sts. from back neck 10 sts. from 1st sleeve, 28 (30, 32) sts. from round neck and 10 sts. from 2nd sleeve. 70 (74, 78) sts. Using M wool. T10. K. 1 row. Trans. sts. to ribber to make 2 x 2 rib. T7/7. K. 8 rows. Cast off loosely by hand.

TO MAKE UP

Pin out and press with a warm iron over a

his 'n' hers matching waistcoats

damp cloth. Join raglan, side and sleeve seams. Press seams.

TREWS

With M case on 62 (66, 70) sts. as 2 x 2 rib. 000. T10/8. K. 10 rows. Inc. 1 st. each end of next and foll. 6th (8th, 10th) row, 9 times in all. 80 (84, 88) sts. K. straight to 66 (84, 104) rows.

Shape Crutch

000. Cast off 4 sts. at beg. of next 2 rows. Dec. 1 st. each end of next and foll. alt. row 7 times in all. K. straight to 50 (54, 58) rows. T8/6. K. 10 rows. Cast off. K. 2nd leg to match.

TO MAKE UP

Join leg seams, then front and back seams. Sew elastic inside waist using casing st. Press seams.

HAT

With M cast on 100 (108, 116) sts. as 2 x 2 rib. T10/8 working in stripes of 6 rows in each colour. K. 36 (40, 44) rows. T7/5. K. 30 rows. Slip sts. onto No. 9 knitting needles. Next row K. 2 tog., P. 2, rep. to end. Next row. P. 2 tog., K. 1, rep. to end. Break wool and thread end through.

TO MAKE UP

Pull wool tight and fasten securely. Join side seam. Press seam.

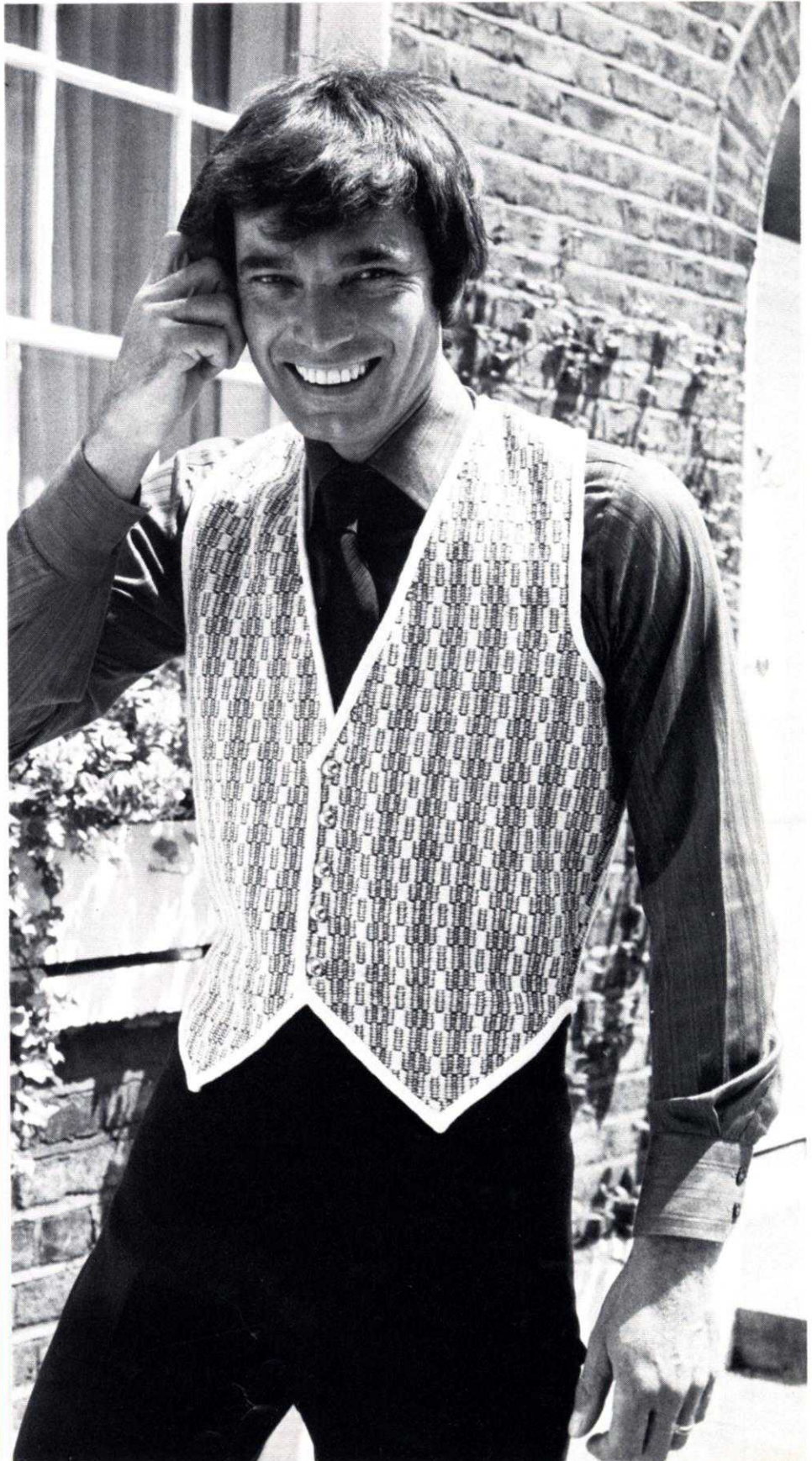
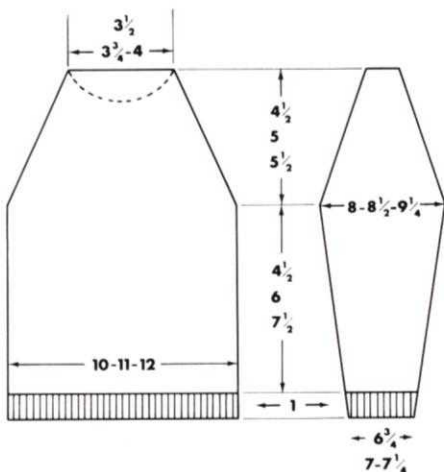
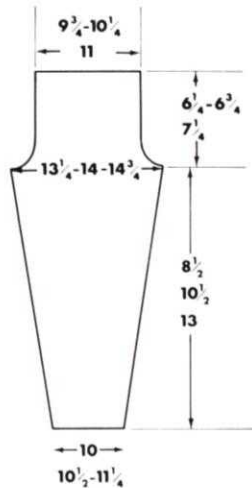

WOVEN WAISTCOAT

Materials

6 (6, 6, 7, 7) ozs. Emu Scotch 4 ply. 3 ozs. D.K. for weaving. 3 yds. Braid for edging. 5 buttons.

Measurements

To fit chest/bust sizes 32 (34, 36, 38, 40) ins.
Length to shoulder 17½ (18, 18½, 19, 19½) ins.

Tension

T6. 13 sts. and 22 rows to 2 ins.

Abbreviations

K., knit; sts., stitches; inc., increase; dec., decrease; foll., following; alt., alternate; rem., remain; beg., beginning; T., tension; 000., set row counter to 000.

Notes

Buttonholes to be worked on appropriate front, over needles 5 and 6 from front edge on rows 6, 22, 38, 54, 70.

BACK

With 4 ply cast on 86 (92, 98, 104, 110) sts. by hand. 000. T6. K. 2 rows. Foll. weaving pattern chart. K. 6 rows. Inc. 1 st. each end of next and every foll. 6th row 12 times in all 110 (116, 122, 128, 134) sts. K. straight to 104 rows.

Shape Armholes

000. Cast off 6 sts. at beg. of next 2 rows. Dec. 1 st. each end of every row 11 (12, 13, 14, 15) times 76 (80, 84, 88, 92) sts. rem. K. straight to 88 (94, 100, 106, 112) rows.

Shape Shoulders

Cast off 4 sts. at beg. of next 8 rows, 3 (4, 5, 6, 7) sts. at beg. of next 2 rows. Cast off rem. 38 (40, 42, 44, 46) sts.

LEFT FRONT

With 4 ply cast on 4 (5, 4, 5, 4) sts. by hand. T6. K. 2 rows. Foll. weaving pattern,

inc. 1 st. each end of every row 5 (7, 11, 13, 17) times in all, then on every alt. row 17 (16, 14, 13, 11) times. K. 1 row. 48 (51, 54, 57, 60) sts. 000. (see notes for buttonholes). K. 8 rows. Inc. 1 st. (side edge) at beg. of next and every foll. 6th row 12 times in all 60 (63, 66, 69, 72) sts. 75 rows.

Shape Neck

Dec. 1 st. at left side of next and every foll. 5th row. K. to 104 rows. (K. 1 row extra for Right Front.)

Shape Armholes

000. Cast off 6 sts. at beg. of next row. K. 1 row. Dec. 1 st. at armhole edge on next 11 (12, 13, 14, 15) rows, at the same time continue to dec. at neck edge on every 5th row until 19 (20, 21, 22, 23) sts. rem. K. to 88 (94, 100, 106, 112) rows.

Shape Shoulder

Cast off 4 sts. at beg. of next and foll. alt. rows until 3 (4, 5, 6, 7) sts. rem. K. 1 row.

Cast off.

RIGHT FRONT

K. as Left Front reversing all shapings.

TO MAKE UP

Pin out and press with a warm iron over a damp cloth. Join shoulder and side seams. Sew braid all round armholes and outer edges of garment, mitre at point on Front. Neaten buttonholes. Sew on buttons.

FAIR-ISLE WAISTCOAT

Materials

4 (4, 5, 5, 6) ozs. Emu Scotch 4 ply in main colour. 4 (4, 5, 5, 6) ozs. Contrast. Braid for edging. 5 buttons.

Measurements

To fit chest/bust sizes 32 (34, 36, 38, 40) ins.
Length to shoulder 17½ (18, 18½, 19, 19½) ins.

Tension

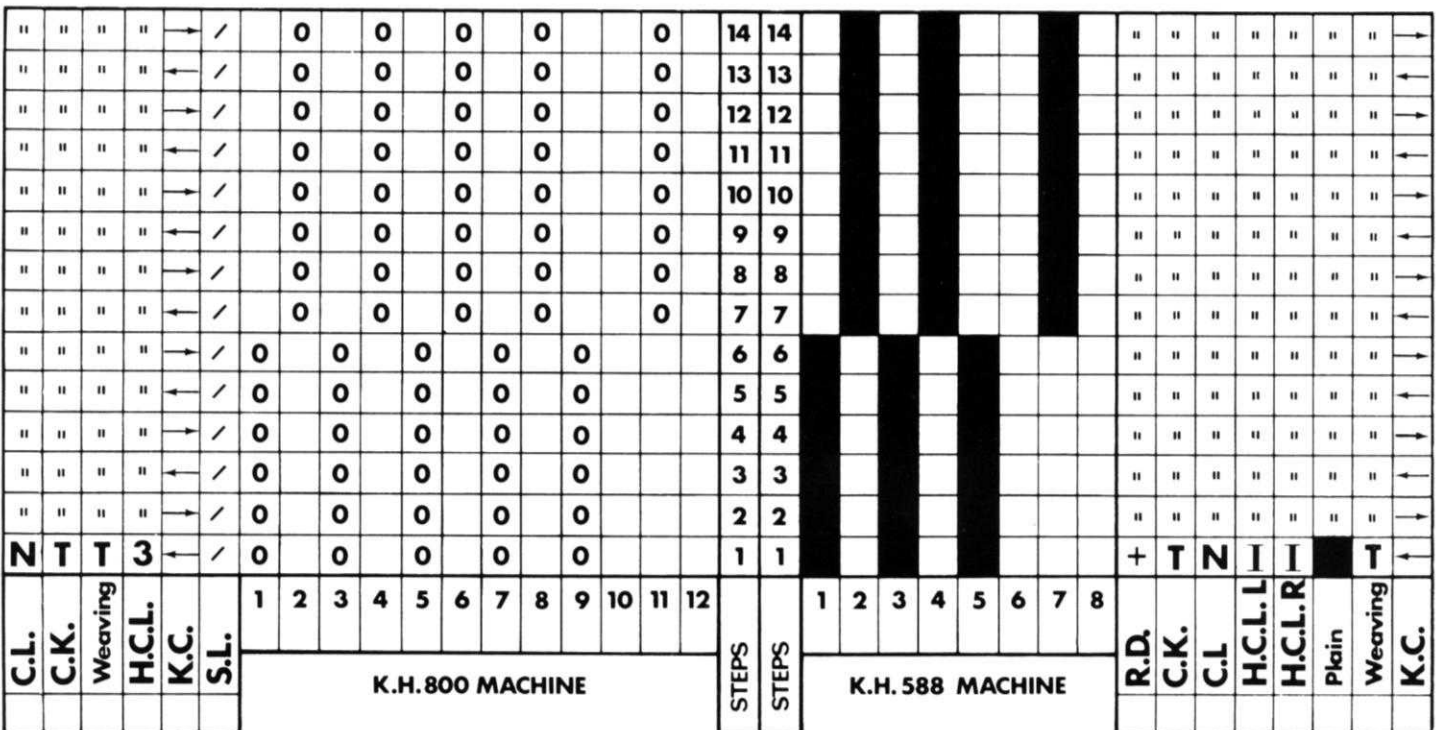
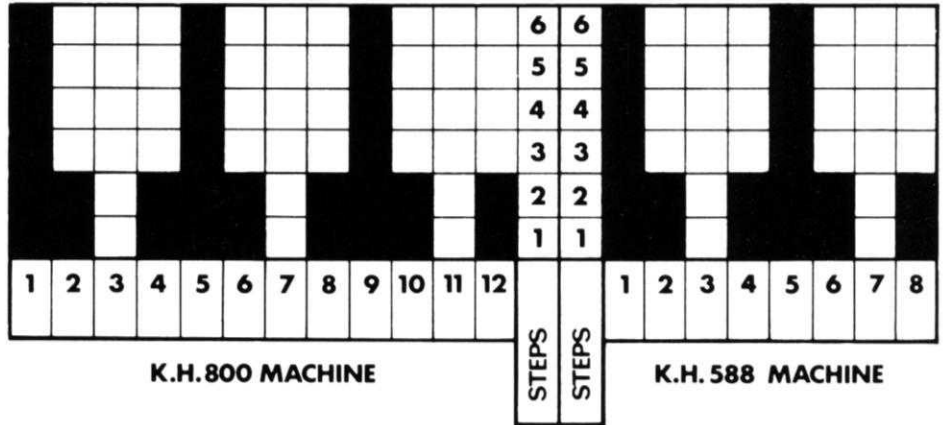

T7. $8\frac{1}{2}$ sts. and $9\frac{1}{4}$ rows to in.

Abbreviations

K., knit; sts., stitches; inc., increase; dec., decrease; foll., following; alt., alternate; rem., remain; beg., beginning; T., tension; 000., set row counter at 000.

Notes

Buttonholes to be worked on appropriate front, over needles 6 and 7 from front edge on rows 6, 20, 34, 48, 62.

BACK

With M, cast on 112 (120, 128, 136, 144) sts. by hand. 000. T7. K. 2 rows. Foll. Fair-Isle pattern chart. K. 8 rows. Inc. 1 st. each end of next and foll. 4th row 15 times in all. 142 (150, 158, 166, 174) sts. K. straight to 88 rows.

Shape Armholes

000. Cast off 8 sts. at beg. of next 2 rows. Dec. 1 st. each end of every row 14 (15, 16, 17, 18) times. 98 (104, 110, 116, 122) sts. rem. K. straight to 74 (78, 84, 88, 92) rows.

Shape Shoulders

Cast off 5 (5, 5, 6, 6) sts. at beg. of next 8 rows, 3 (5, 7, 5, 7) sts. at beg. of next 2 rows. Cast off rem. 52 (54, 56, 58, 60) sts.

RIGHT FRONT

With M, cast on 4 sts. by hand. T7. K. 2 rows. Foll. Fair-Isle pattern, inc. 1 st. each end of every row 25 (29, 27, 31, 35) times in all, then on every alt. row 4 (2, 6, 4, 2) times. K. 1 row. 62 (66, 70, 74, 78) sts. 000. (See notes for buttonholes.) K. 10 rows. Inc. 1 st. (side edge) at beg. of next and foll. 4th row 15 times 77 (81, 85, 89, 93) sts. 67 rows.

Shape Neck

Dec. 1 st. at left side of next and every foll. 3rd row, K. to 88 rows. (K. 1 row extra for left front.)

Shape Armholes

000. Cast off 8 sts. at beg. of next row. K. 1 row. Dec. 1 st. at armhole edge on next 14 (15, 16, 17, 18) rows at the same time continue to dec. at neck edge on every 3rd row until 23 (25, 27, 29, 31) sts. rem. K. straight to 74 (78, 84, 88, 92) rows have

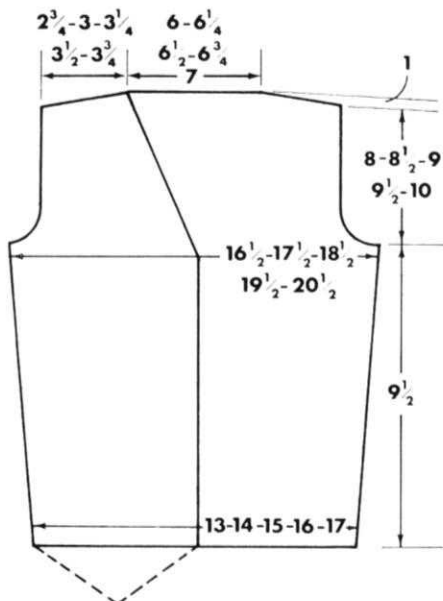

been worked.

Shape Shoulder

Cast off 5 (5, 5, 6, 6) sts. at beg. of next and foll. alt. rows until 3 (5, 7, 5, 7) sts. rem. K. 1 row. Cast off.

LEFT FRONT

K. as right front reversing all shapings.

TO MAKE UP

Pin out and press with a warm iron over a damp cloth. Join shoulder and side seams. Sew braid all round armholes and outer edges of garment, mitre at points on front. Neaten buttonholes. Sew on buttons. Press seams.

you write...

Mrs. D. Davies
48 Hallett Avenue
Tranmere 5073
Sth Australia

I am Dawn Davies, who wrote to you nearly two years ago, whilst visiting Empisal knitting machine owners, on Eyre peninsula in Sth. Australia. After having personal help and tuition they improved wonderfully, I have knitted lovely things. At their request, I returned to their country town, Kielpa, in Sept. '71, to give a demonstration of the knitting machine at their Country Womens' Assc. meeting. They wanted me to visit them again this month, and bring them up to date with latest ideas, but I am too busy to go at present. Some of these 'girls' have subscribed to *Stitchin' time* and are very pleased with the books received. I have intended subscribing for some time, but having access to a friend's copies, have been lazy, but realise it's much better to have one's own, so at last I'm sending a subscription and will be eagerly awaiting arrival of my first copy.

I wonder if you would be good enough to send me any information or literature—anything—which would be of interest or help us with our club which is flourishing in its fourth year, with many foundation members still regular attendants. Seeing the progress each member makes, gives me great pleasure and the satisfaction of knowing that starting such a club was really worthwhile. Our club at Rostrevor grew so much—45 present at times—it was too many for one machine, so we started two more clubs in other suburbs. (I think I told you before, our club was formed independently of the Empisal agency here. I tried to get them actively interested, but to no avail, so we saved up and bought our own machine.)

We also have a dayclub, the idea of this is, one day each month we go to the home of a member, i.e. a different member each month, arriving about 10.30 a.m., take our lunch, and a 'pot of tea' is made by the hostess of the day, and we continue with our knitting till about 3–3.30 p.m. The entire day is taken up, exchanging ideas, demonstrating, and showing garments knitted since last meeting. You can imagine what wonderful days we have, we call them our 'Knit wits at home'. All these knitters would be extremely interested in any help you could pass on to us. Also would it be possible for us to be included in your *Stitchin'* link scheme? I, personally would love to correspond with knitters, or a club in England or Ireland, and am sure others would too. I read in a *Stitchin' time* of an English lady visiting Australia and attending a club, but it was not ours in Sth. Australia. I think it must have been in Victoria, we certainly would welcome any visitors from England. I am still President of our club, so anyone can write c/o my address. We have been keenly interested to note you have a new machine with 12

button patterns, and wonder how long before we get it out here.

Yours faithfully,
Dawn Davies



Mrs. B. Rice
161 Dublin Road
Clough Hage P.O.
Newry
Ireland

I have just received my first ever *Stitchin' time* and I must say I like it.

You asked readers to write to you so here is my story—for twelve years I had a petrol filling station, it was situated about 300 yards from the Eire border. From 1969 we had all sorts of trouble on the border, bombings, shootings and kidnapping—U.D.R. men—we survived it until February '72 when our premises were partly demolished by a 300 lb. bomb. We rebuilt again and started business in April, but in the 23rd July '72 we were completely bombed out and this time we gave up.

On the morning of the 23rd July I was sitting at my knitting machine, knitting and keeping an eye on the attendant, when at about 12 o'clock noon, three men with guns came, they robbed the till and then placed the bomb in the centre of the shop. It was time to get out, so I grabbed my hand bag and ran towards the door. Then I remembered I had just completed a lovely cardigan in Random wool for my favourite grand daughter, I dashed back, grabbed it and ran, but I wasn't able to rescue my machine. The result was I had to get a new one, but this time I changed to a Brother and I am very pleased with it. I find it much more simple to operate than the Knit Master and now with the help of *Stitchin' time* I hope to do lots of things in the future.



Mrs. M. Briggs
21 Heol Cen Copyn
Loughor
Swansea
Glamorgan

Dear Editor,

Am renewing my subscription; love your magazine it is very good value and nicely presented, you have got another winner with your letter page.

I have owned my 800 machine for one

year. The lovely designs you put before us have really done me good—yes, I mean exactly that, at first I was in the same frame of mind as Mr. L. Naylor so made a resolution and lost two stone in weight, problem solved!! (use less wool that way too)!!

Perhaps a less drastic answer to all the 'chubbies' or 'fatties' call them what you may, is a Knitleader, I have one and find that designs can be adapted to suit most requirements and in whatever yarn you wish, the diagrams in your magazine are a great help, also of course there is the rewarding task of inventing your own designs.

I have two small children and find my energy and creativity rather drained at times and think sometimes how nice it would be if full size diagrams and designs were available to purchase for use with Knitleader.

As well as knitting for the family I also do all our sewing so am now completely independent of shops for ready made clothes, the only use I make of those shops is to drag (his word) my husband round to point out how much I am saving him—he's convinced—and thinks it about time I made him a suit!!! Do you think if I did it would be grounds for divorce?

Could you possibly give us some patterns for tights for little girls aged two upwards please.

Let's have lots of those sexy short jumpers, just right for the new slim me (even dare to wear trousers now—wonderful)!

Thank you for your help in liberating me from my panti girdles (now there's a thought to conjure with...)

Keep up the good work, as far as I'm concerned you are smashing.

Yours Sincerely,
Mary Briggs (Mrs.)

SUBSCRIPTION WINNER



Mrs. P. Hocking
3 Wilson Close
Maidstone
Kent

I was asked by a friend if I would knit a plain green sweater for her friend's young son. When I called on Mrs. B her 'young son' had a 38 ins. chest, not the toddler I had imagined. The sweater then changed to a black fancy patterned one with a 'neck low enough to show a collar'. Well I should have known then it couldn't be plain sailing.
continued on page 21

With black, cast on 14 sts. and work 2 rows. Increase 1 st. at end of every row to 28 sts. Work 14 rows. Decrease 1 st. at beginning and end of every third row until 18 sts. remain. Cast off after working 1 more row.

COLLAR

Using same colour as belt, cast on 46 sts. and work 1 row. Decrease fully fashioned method at either alternate end of every row to 36 sts. Work 1 row and cast off.

TO MAKE UP

Stitch body sections together on wrong side leaving open at neck. Turn and stuff firmly. Stitch head, stuff and sew firmly in place using ladder stitch; collar hides the neck join.

HAIR

Knot in lengths of wool. Add features and bow tie.



MERMAID

Materials

1 oz. green/blue Double Knitting wool—plain or glitter. 1 oz. pale contrast Double Knitting for top body. $\frac{1}{2}$ oz. 4 ply or Double Knitting for hair. Felt for features. Kapok for filling.

Tension

$8\frac{1}{2}$ on knitting machine or size 11 needles for hand work, stocking stitch.

TO MAKE

LOWER BODY AND TAIL (make 2)

Using green/blue cast on 24 sts. Work 24 rows. Decrease 1 st. at beginning and end of next and every following 4th row until 12 sts. remain. Work 1 row. Increase 1 st. at beginning of every row to 24 sts. Work 4



rows. Divide sts., leaving 12 on stitch holder or in non-working position. Decrease 1 st. at inner edge on every row to 1 st. remaining. Repeat for other 12 sts., decreasing at inner edge, to shape tail.

TOP BODY AND HEAD

Using pale contrast; reverse knitting if desired and pick up the 24 sts. at cast on edge. If body is required to 'bend' pick sts. up on slant. Work 16 rows. Decrease 1 st. at beginning and end of next and every following alternate row until 14 sts. remain. Work 1 row. Increase 1 st. at beginning of every row to 26 sts. Work 14 rows. Decrease 1 st. beginning and end of next and every following third row until 16 sts. remain. Cast off. Repeat for second side of body.

ARMS (make 2)

Cast on 2 sts. at shoulder and work 1 row. Increase 1 st. at beginning of every row to 22 sts. Work 14 rows. Decrease 1 st. at beginning and end of every third row until 10 sts. remain. Thread wool through and fasten off tightly for hands. Join body sections together on wrong side, leaving top of head open, (raglan armhole). Turn and stuff firmly. Close seam. **For hair** Wind wool on a piece of card—st. in place at centre parting. Use fabric adhesive for features. Crochet a decoration for neck.

FISH

Materials

1 oz. Double Knitting in main colour or 1 oz. 4 ply. $\frac{1}{2}$ oz. Double Knitting contrast colour or $\frac{1}{2}$ oz. 4 ply. Felt for eyes. Kapok for filling.

Tension

$8\frac{1}{2}$ D.K. T6 for 4 ply, or size 11 needles for hand work.

BODY

Cast on 36 sts. and work 20 rows. Decrease 1 st. at beginning and end of next and every following 3rd row until 12 sts. remain. Work 1 row. Increase 1 st. at beginning of next and every following row to 30 sts. Work 1 row and cast off.

MOUTH

Reverse the knitting and pick up the 36 sts. of cast on edge (purl side is right side). In contrast wool work 4 rows. (a) Decrease 1 st. at beginning and end of next row. (b) Decrease 1 st. at beginning only of next row. Repeat rows (a) and (b) until 4 sts. remain. Work 2 rows and cast off. Make a second side, remembering to reverse shapings at mouth piece, by decreasing at end of row B.

TO MAKE UP

Stitch body sections together on wrong side leaving an opening. Turn and stuff firmly. For fins Knot in lengths of wool and trim to shape. Add eyes and mouth.

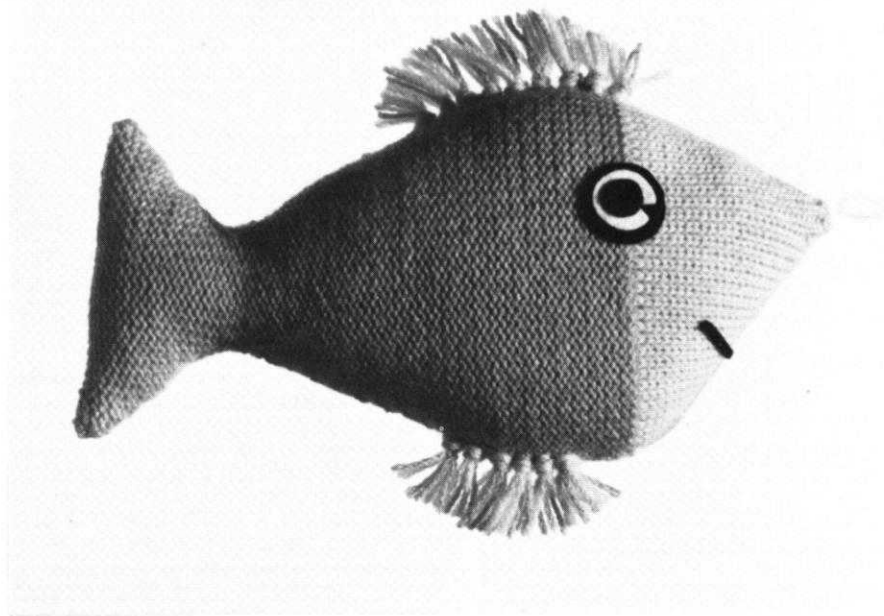

mock rib polo neck sweater



Materials

9 (11, 13, 15) 25 grms. balls Emu Machine Washable Double Knitting wool.

Measurements

To fit chest sizes 24 (26, 28, 30) ins.

Length to shoulder 14 (16, 18, 20) ins.

Sleeve seam $10\frac{1}{2}$ (12, $13\frac{1}{2}$, 15) ins.

Tension

T10. 14 sts. and $16\frac{1}{2}$ rows to 2 ins.

Abbreviations

K., knit; sts., stitches; inc., increase; dec., decrease; alt., alternate; beg., beginning; foll., following; rem., remaining; T., tension; trans., transfer; 000., set row counter to 000; H.C.L's., holding cam levers.

Notes

All welts Bring forward to B pos. number of needles given. Return centre and every foll. alt. needle to each side to A pos. Cast on with waste and K. a few rows. Change to main wool. T7. K. 19 rows. Make a hem and K. the row.

Mock rib pattern for main part of garment. Trans. centre and every foll. 8th st. each side to adjacent needle. Return empty needles to A pos. Needles in A pos. are

counted as sts. when shaping garment. Make a chain over empty needles when casting off.

BACK AND FRONT (Alike)

Bring forward 87 (95, 103, 111) needles. Make welt (see notes). 000. T10. Set machine for mock rib pattern. K. 68 (80, 92, 104) rows. (Adjust length here if required.)

Shape Armholes

000. Cast off 4 sts. at beg. of next 2 rows. Dec. 1 st. each end of foll. 4 (5, 6, 7) rows. 71 (77, 83, 89) sts. K. straight to 30 (34, 36, 40) rows.

Shape Neck

Slip centre 17 sts. onto a knitting pin. Push needles at left to E pos. H.C.L's III. Dec. 1 st. at neck edge on next and every foll. row until 21 (23, 25, 27) sts. rem. K. straight to 40 (44, 48, 52) rows.

Shape Shoulder

Cast off 8 (8, 9, 9) sts. at beg. of next and foll. alt. row. K. 1 row. Cast off rem. 5 (7, 7, 9) sts. Rejoin wool. H.C.L's I. K. left side to match.

SLEEVES

Bring forward 47 (49, 51, 53) needles. Make welt. 000. T10. Set machine for mock rib pattern. K. 10 rows. Inc. 1 st. each end of next and foll. 9th (8th, 8th, 7th) row 7 (9, 11, 13) times. 61 (67, 73, 79) sts. K. straight to 80 (92, 104, 116) rows. (Adjust length here if required.)

Shape Top

000. Cast off 4 sts. at beg. of next 2 rows. Dec. 1 st. at each end of next 4 (5, 6, 7) rows then every alt. row 7 (6, 6, 5) times. Dec. 1 st. at each end of next 6 (9, 10, 13) rows. Cast off.

POLO COLLAR

Join right shoulder seam. With wrong side facing pick up and place on machine 103 (109, 117, 125) sts. from round neck. T10. K. 1 row. Trans. alt. sts. to adjacent needles and return empty needles to A pos. T8. K. 16 rows. T9. K. 32 rows. T8. K. 16 rows. Cast off loosely.

TO MAKE UP

Pin out and press with a warm iron over a damp cloth. Join left shoulder, side and sleeve seams. Set in sleeves. Join collar seam. Turn to inside and slip st. in place. Press seams.

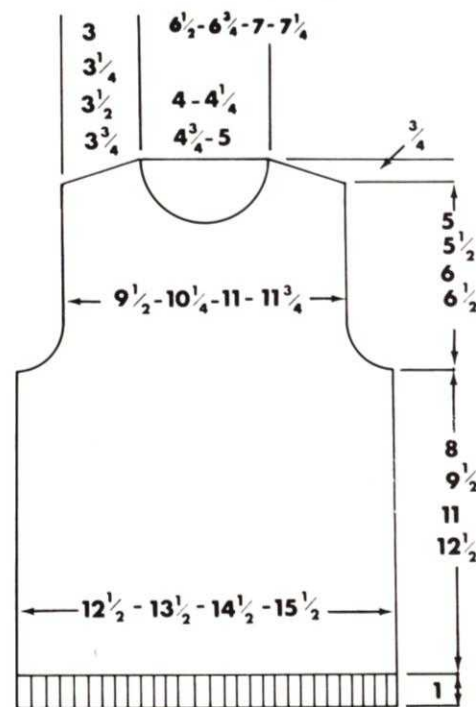
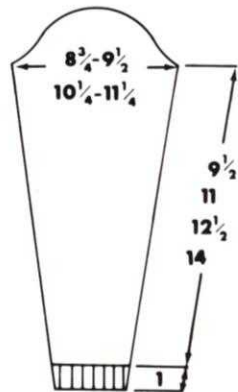

mans cable sweater

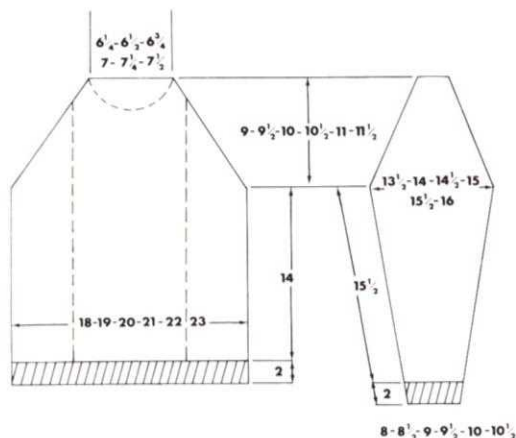

Materials

15 (16, 17, 18, 20, 21) ozs. Robin Tricel Perle 4 ply.

Measurements

To fit chest sizes 34 (36, 38, 40, 42, 44) ins.
length to back neck 25 (25½, 26, 26½, 27, 27½) ins.
cuff seam 18½ ins.

Tension

T6/6. 15 sts. and 21 rows to 2 ins.

Abbreviations

K., knit; sts., stitches; dec., decrease; inc., increase; beg., beginning; alt., alternate; rem., remaining; tog., together; trans., transfer; M.B., main bed; T., tension; 000.,

set row counter to 000; H.C.L's., holding cam levers.

Notes

Fully fashioned dec. on sleeve raglan is worked by trans. the 6th st. onto 7th needle and moving 5 end sts. one needle in.

Cable Panel

Working from each side of centre O. Trans. to ribber 2nd and 3rd st. miss 2 sts. Trans. next 10 sts. miss 4 sts. Trans. next 10 sts.

Cable Stitch

K. 4 rows. On centre group of three panels. Move stitch 1 over 2. K. 4 rows. Repeat movement on centre panels also move sts. 1 and 2 over 3 and 4 on two outer panels of 4 sts. These 8 rows complete one pattern. Repeat throughout.

BACK

Cast on 134 (142, 150, 158, 166, 174) sts. as 1 x 1 rib. T4/4. K. 22 rows. Trans. ribber sts. to M.B. * 000. T6. K. 146 rows.

Shape Raglan

000. Cast off 4 sts. at beg. of next 2 rows. K. 2 rows. Dec. 1 st. each end of next and foll. 4th row 6 (6, 6, 5, 5, 5) times **, then on every foll. alt. row until 46 (48, 50, 52, 54, 56) sts. rem. K. 1 row. Slip sts. onto knitting pin.

FRONT

K. as Back to *. Arrange sts. for cable panel (see notes). T6/6. Follow cable pattern and K. as back to **. K. 1 row. Dec. 1 st. each end of next and foll. alt. row until 66 (70, 74, 78, 82, 86) rows have been worked.

Shape Neck

Slip centre 20 (20, 20, 22, 22, 22) sts. onto a pin. Push sts. at left to E. pos. H.C.L'S III. Continue to work cable pattern and dec. at raglan as before. K. 1 row. dec. 1 st. at neck edge on next and foll. alt. rows until 5 sts. rem. Keep neck edge straight and dec. on raglan edge until 2 sts. rem. K. 1 row. Cast off H.C.L's I. K. left side to match reversing all shapings.

SLEEVES

Cast on 58 (62, 66, 70, 74, 78) sts. as 1 x 1 rib. T4/4. K. 32 rows. Trans. ribber sts. to M.B.

000. T6. K. 10 rows. Inc. 1 st. each end of next and foll. 6th row 22 times. 102 (106, 110, 114, 118, 122) sts. K. straight to 162 rows. (Adjust length here if required.)

Shape Raglan

000. Cast 4 sts. at beg. of next 2 rows. K. 2 rows. Dec. 1 st. (see notes) each end of next and foll. 4th row 7 (8, 9, 9, 10, 11) times and then on every alt. row until 16 sts. rem. K. 1 row. Slip sts. onto a pin.

NECKBAND

With wrong side facing pick up and place on machine 46 (48, 50, 52, 54, 56) sts. from back neck, 16 sts. from 1st sleeve, 68 (70, 72, 76, 78, 80) sts. round front neck, 16 sts. from 2nd sleeve, 146 (150, 154, 160, 164, 168) sts. T6. K. 1 row. Trans. alt. sts. to ribber. T4/4. K. 40 rows. T10/8. K. 1 row. Trans. ribber sts. to M.B. Chain cast off.

TO MAKE UP

Pin out and press with a cool iron over a dry cloth. Join raglan side and sleeve seams. Turn neckband to inside and slip st. in place. Press seams.

boys sleeveless pullover



In 4 ply crepe

Materials

Listers Lavenda 4 ply crisp crepe wool 3 (3, 4) ozs. brown. 1 (1, 2) ozs. each of red, yellow, royal, green.

Measurements

26 (28, 30) ins. chest. (Actual measurements.)

13 (14½, 16) ins. back length.

Tension

T8. 7 sts. and 9 rows to 1 in.

Abbreviations

Sts., stitches; alt., alternate; inc., increase; incl., inclusive.

Notes

K. carriage direction is not shown as the stripes come out to odd numbers in places. The pattern will vary slightly on the

different sizes but the overall effect will be the same.

BACK

Ribbers Cast on 95 (103, 109) sts. T5 and K. 10 (12, 14) rows in K. 1. P. 1. rib. Transfer sts. to main bed, inc. 1 st.

Single bed machines Cast on over alt. needles. 48 (52, 55) sts. T5 and K. 18 (20, 22) rows, bring forward alt. empty needles and hang up cast on sts. onto them.

All machines 000. T8. 2nd and 3rd sizes only. K. 2 rows brown, 2 rows green, 2 rows brown and 2 rows yellow.

All sizes K. 2 rows brown, using royal as laying thread, work steps 1 to 6 from chart. K. 1 row brown, 2 rows red, 2 rows brown, 2 rows yellow, 1 row brown. Using green as laying thread work steps 8 to 13 incl. thread in yellow, using royal as laying thread work steps 14 to 17 incl. Thread in brown, using green as laying thread, work steps 18 to 23 incl. K. 1 row brown, 1 row red, 1 row royal, 1 row yellow, 1 row green, 1 row brown. Using red as laying thread K. from steps 1 to 6 incl. K. 1 row brown.

Third size only K. 1 row royal, 1 row green, 1 row brown, 1 row red, 1 row yellow, 1 row brown. **All sizes** Using royal as laying thread work steps 25 to 31 incl. K. 1 row brown, 2 rows green, 1 row brown, 2 rows red, 1 row brown. Row counter 59 (67, 73).

Shape Armholes

000. Using yellow as laying thread, work steps 18 to 23 incl. **at the same time** cast off 5 sts. at beg. of next 2 rows. Dec. 1 st. at both ends of every row to 56 (60, 64) sts. Thread up red and using green as laying thread, work from steps 14 to 17 incl. With brown threaded, using yellow as laying thread, work steps 8 to 13 incl. K. 1 row brown, 1 row royal, 1 row green, 1 row brown, 1 row red, 1 row yellow, 1 row brown. Using green as laying thread, work steps 1 to 6 incl. K. 1 row brown, 1 row royal, 1 row red, 1 row yellow, 1 row brown. Using red as laying thread work steps 8 to 13 incl. Thread up with yellow, using royal as laying thread work steps 14 to 17 incl. With brown threaded, using red as laying yarn, work steps 18 and 19. **On 1st size only** Cast off 6 sts. at beg. of next 4 rows. (Steps 20 to 23.) Put sts. on waste yarn. For 2nd and 3rd sizes continuing from chart after working steps 18 and 19 (mentioned previously), work steps 20 to 23. K. 2 rows brown, 1 row green, 1 row red, 1 row royal, 1 row yellow. Thread up with brown wool. **2nd size only** Cast off 7 sts. at beg. of next 4 rows. Put sts. on waste yarn. **3rd size only** With brown K. 2 rows. Using royal as laying thread, work steps 1 to 6 from chart. Using brown only, cast off 8 sts. at beg. of next 4 rows. Put sts. on waste yarn.

FRONT

Work as back to row counter 20 (24, 28). Shape neck by putting centre 16 (18, 20) sts. on waste or on holder. Continue on right set of sts. First (still following pattern as given for back). Dec. 1 st. at neck edge of every row to 12 (14, 16) sts. Continuing in pattern, work without further shaping to row counter 50 (60, 68). Cast off at beg. of

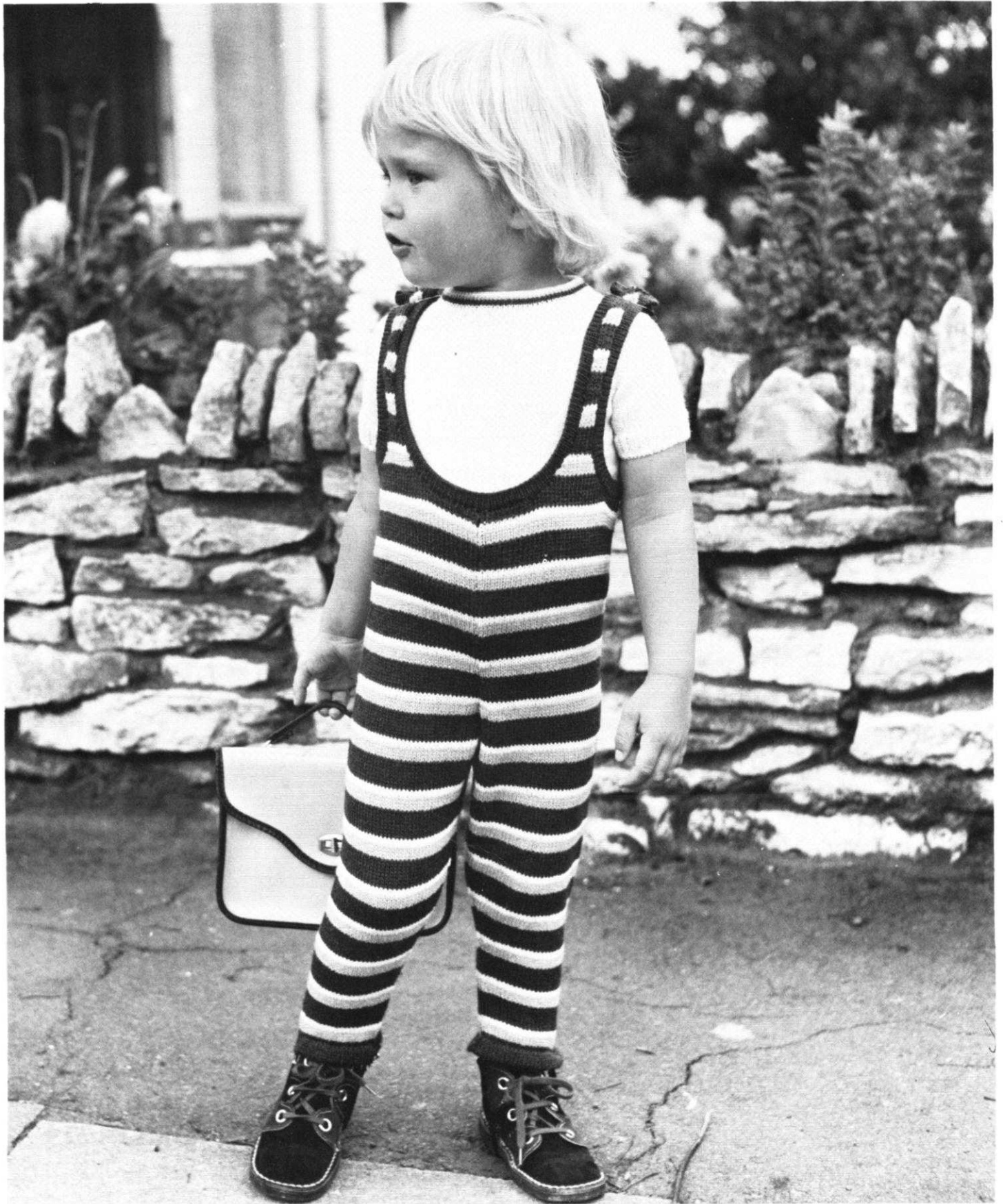

childrens matching sweaters

PATTERN BY COURTESY OF 'PINS AND NEEDLES' MAGAZINE



Materials

For either version 6 (7, 8, 9, 11, 12) ozs. Patons School Knitting 4 ply, Patonised, pair of No. 12 needles for ribbing.

Measurements

To fit 24 (26, 28, 30, 32, 34) in. chest. Length 15½ (17, 18½, 20, 21½, 23½) ins., Sleeve seam 10½ (11½, 12½, 14, 15, 16½) ins., adjustable. Figures in brackets refer to larger sizes.

Abbreviations

K., knit; P., purl; st(s), stitch(es); in(s), inch(es); dec., decrease; inc., increase; RC., row counter; WP., working position; NWP., non-working position; TBL., through back of loop; twisted single rib, K. 1 TBL. and P. 1 alternately.

Tension

7 sts. and 10 rows to 1 in. over stocking st.

Note

These garments can be made on any single bed machine with a minimum of 124 needles.

'V' NECK VERSION

BACK

Using No. 12 needles cast on 92 (98, 106, 112, 120, 126) sts. Work 2 ins. in twisted single rib. Place sts. on to machine and set for correct tension. Work 74 (84, 94, 104, 114, 124) rows. **To shape raglan armholes** Dec. 1 st. at beginning of every row until 36 (38, 40, 42, 44, 46) sts. remain. Slip sts. on to spare needle.

FRONT

Work as for back until front is 10 rows less than back to armholes. Divide sts. for neck. Place 46 (49, 53, 56, 60, 63) needles at left into NWP, and work on remaining 46 (49, 53, 56, 60, 63) sts.

RIGHT HALF FRONT

To slope front edge Dec. 1 st. at neck edge on the next and 2 following 4th rows. Work 1 row. **To shape armhole and continue front sloping** Dec. 1 st. at armhole edge on the next and every alternate row until 1 st. remains, at the same time continue to dec. at front edge on every 4th row for a further 7 (8, 11, 12, 15, 18) dec. rows, then on

every 3rd row for 8 (8, 6, 6, 4, 2) dec. rows more. Fasten off. Push remaining 46 (49, 53, 56, 60, 63) needles into WP.

LEFT HALF FRONT

Work as for right half front.

SLEEVES (both alike)

Using No. 12 needles cast on 40 (44, 46, 50, 54, 58) sts. Work 1½ ins. in twisted single rib. Transfer sts. on to machine. RC. 000. Work 2 rows, then inc. 1 st. at both ends of the next and every following 7th (7th, 7th, 6th, 6th, 7th) row until there are 62 (68, 74, 80, 88, 94) sts. Continue straight until RC. reads 86 (96, 106, 120, 130, 146) rows, or length required. **To shape Raglan Top** Work as for raglan armhole shaping on back until 6 (8, 8, 10, 10, 12) sts. remain. Slip sts. on to a spare needle.

NECKBAND

Leaving right back raglan seam open, join raglan seams. With right side facing, using No. 12 needles, K. 36 (38, 40, 42, 44, 46) sts. from back, 6 (8, 8, 10, 10, 12) sts. from left sleeve, pick up and K. 38 (40, 42, 46, 50, 52) sts. from left front neck edge, 1 st. from centre 'V', 39 (41, 43, 47, 49, 53) sts. from right front neck edge, K. 6 (8, 8, 10, 10, 12) sts. from right sleeve. 126 (136, 142, 156, 164, 176) sts. Work 8 rows in twisted single rib, dec. 1 st. at each side of the centre st. Cast off in rib.

TO MAKE UP

Avoiding the ribbing, press each piece on the wrong side with a warm iron over a damp cloth. Join remaining raglan seam, continuing seam across neckband. Join side and sleeve seams. Press seams.

ROUND NECK VERSION

BACK

Work as given for 'V' neck version.

FRONT

Work as for back until 52 (54, 58, 60, 64, 68) sts. remain in raglan shaping. Divide sts. for neck. Slip centre 20 (20, 20, 22, 22, 24) sts. on to a spare length of yarn, then push 16 (17, 19, 19, 21, 22) sts. at left into NWP, and work on remaining 16 (17, 19, 19, 21, 22) sts. at right. **1st Point** Continuing to dec. at armhole edge on every alternate row, dec. 1 st. at neck edge on every alternate row until 1 st. remains. Fasten off. Push 16 (17, 19, 19, 21, 22) needles into WP., rejoin yarn. **2nd Point** Work as for 1st point.

SLEEVES (both alike)

Work as given for 'V' neck version.

NECKBAND

Leaving right back raglan seam open, join raglan seams. With right side facing, using No. 12 needles, K. 36 (38, 40, 42, 44, 46) sts. from back, 6 (8, 8, 10, 10, 12) sts. from left sleeve, pick up and K. 11 (11, 12, 12, 13, 13) sts. from left front neck edge, K. 20 (20, 20, 22, 22, 24) sts. from centre front, pick up and K. 11 (11, 12, 12, 13, 13) sts. from right front neck edge, K. 6 (8, 8, 10, 10, 12) sts. from right sleeve. 90 (96, 100, 108, 112, 120) sts. Work 15 rows in twisted single rib. Cast off loosely in rib.

TO MAKE UP

As given for 'V' neck version. Fold neckband in half to the wrong side and neatly slip-st. cast-off edge to the inside.

cabled polo neck jumper



Materials

11 (12, 13, 14) ozs. 4 ply crepe. Plus odd ounce for waste knitting.

Measurements

Chest 28 (30, 32, 34) ins.

Length to back neck 19 (20½, 22, 23½) ins.

Sleeve seam 13 (14½, 16, 17½) ins.

Tension

T7. 7½ sts. and 10 rows to 1 in.

Abbreviations

Sts., stitches; inc., increase; dec., decrease; patt., pattern; alt., alternate; foll., following; rem., remaining; beg., beginning; H.C.L's., holding cam levers; T., tension; f.f., fully fashioned—place the 3rd and 4th sts. onto

action man outfit

the 5th and 6th needles and then move up the end 2 sts. to close the gap; 000., set row counter to 000.

BACK

Bring forward 105 (113, 121, 129) needles to working position. Push back every third needle for 2 x 1 rib. ** Cast on in waste wool and K. approx. 10 rows. T5. Using main yarn K. 42 rows rib; knitting centre 2 rows loosely for fold. Pick up the first row of loops in main yarn and place 2 onto each empty needle. K. 2 rows on all needles. ** T7. Working straight patt. as follows: Equally space five cables—each consisting of 4 sts. Cast off the st. either side of the cable and leave the empty needle in the non-working position. Slip the right hand pair of sts. onto a transfer tool and the left hand pair sts. onto another. Place the right hand pair onto the left hand needles and vice-versa. Work 6 rows. The cables should end at even intervals, i.e. End cables: at rows 42 (48, 54, 60). Second cables: at rows 60 (66, 72, 78). Middle cable: at rows 78 (84, 90, 96). Continue working straight until 96 (106, 116, 126) rows worked.

Raglan Shaping

Cast off 3 sts. at beg. of next 2 rows. K. 4 rows. Dec. 2 sts. f.f. at each end of next and every foll. 4th row until 35 (37, 39, 41) sts. rem. K. 1 row. Cast off.

FRONT

K. as back until 46 (52, 60, 68) rows have been worked from beg. of raglan shaping. Carriage at right and H.C.L's buttons on III. Slip centre 17 (21, 21, 19) sts. onto a st. holder. Push sts. to left into holding position and K. on right set of sts. Continue raglan shaping as before. At same time dec. 1 st. at neck edge on every alt. row 8 times in all. 4 sts. rem. K. 2 rows. Dec. once more at raglan edge only. Cast off. H.C.L's buttons onto I. Work other side to match.

SLEEVES

Bring forward 55 (57, 59, 61) needles and push back every 3rd needle for 2 x 1 rib. K. as back from ** to **. 000. T7. Work 10 rows. Now inc. 1 st. each end of next and every foll. 8th row until there are 75 (81, 87, 93) sts. Work straight until 110 (126, 140, 156) rows worked.

Raglan Shaping

Work as given for back until 11 (13, 13, 15) sts. rem. (Casting off 1 st. f.f. each end of last row where necessary.) K. 1 row. Cast off.

POLO NECK (st. right side, sleeve and raglan seams)

With right side facing pick up 33 (37, 37, 39) sts. from back neck, 11 (13, 13, 15) sts. from 1st sleeve, 15 sts. down right neck, 17 (21, 21, 25) sts. across centre front, 15 sts. up left neck, and 11 (13, 13, 15) sts. from 2nd sleeve. 102 (114, 114, 126) sts. in all. Work 2 rows on all needles. Cast off every 3rd st. for 2 x 1 rib. T5. K. 40 rows. T6. K. 18 (24, 24, 30) rows. T5. K. 20 rows. K. 2 rows on all needles. Cast off loosely.

TO MAKE UP

Press with a warm iron over damp cloth. Sew raglan, side and sleeve seams. Fold collar under and slip-st. in place. Press seams.



This Pattern is only suitable for Machines with Ribbing Attachments

Materials

Marriners 4 ply crepe. $\frac{1}{2}$ oz. White. $\frac{1}{2}$ oz. Navy. $\frac{1}{4}$ oz. Red. 2, No. 12 knitting needles. Length of shirring elastic.

Measurements

To fit 12 ins. doll.

Tension

17 sts. to 2 ins.

Abbreviations

K., knit; P., purl; st(s), stitch(es); rep., repeat; tog., together; inc., increase; dec., decrease; st.st., stocking stitch; beg., beginning; W., white; R., red; N., navy.

SWEATER (Back and Front alike)

With W. cast on 30 sts. and work 6 rows in K. 1 P. 1 rib. * Work 18 rows st.st. Join on R., and work 4 rows R. Break off R., work 2 rows W., join on N. and work 2 rows N. Break off N. *

Raglan Shaping

With W. dec. 1 st. at beg. of every row until 10 sts. remain. Leave sts.

SLEEVES

With W. cast on 14 sts. Work 4 rows K. 1 P. 1 rib. Now inc. 1 st. each end of every 4th row. Work as for back and front from * to *. (26 sts.) To shape raglan with W. dec. 1 st. at beg. of every row until 6 sts. remain. Leave sts.

POLO COLLAR

Join 3 raglan seams. Slip sts. onto needles, work 14 rows K. 1 P. 1 rib. Cast off loosely ribwise.

TROUSERS

To make: beg. at waist. With N. cast on 50 sts. Work 6 rows K. 1 P. 1 rib. Work 6 rows K. 1 P. 1 rib. Work 20 rows st.st. Next row—K. 25, turn. Continue on these sts. only. Work 50 rows then work 2 rows K. 1 P. 1 rib. beg. 2nd row. P. 1. Cast off ribwise. Complete other leg to match.

HELMET

To make: beg. at top of head. With R. cast on 9 sts., work 10 rows st.st. Next row—K. to end. Then pick up and K. 6 sts. along side of work. Next row: P. 15, pick up and P. 6 sts. along other side of work. Work 16 rows straight. Cast off for neck edging, leaving last st. on needle, then with same needle pick up and K. 25 sts. around face edge. Rib 3 rows, beg. 2nd row P. 1. Cast off rib leaving last st. on needle then pick up and K. 27 sts. around neck. Work as for face edge. Cast off loosely ribwise. Join side edge of neck rib.

MAKING UP

Press work. **Sweater** Join remaining raglan collar seam. Join side and sleeve seams. **Trousers** Join centre front seam and leg seams. Thread elastic through waist.

lace tablecloth

Special Notes for making Heirloom Lace

This fine lace knitted on the Jones Lacemaker Knitting Machine is comparable to hand-knitted lace, in fact it would be difficult for anyone to state with certainty the difference. It is made entirely with Coats Mercer Cotton so apart from looking beautiful it will last as an Heirloom should. This is genuine lace, not to be confused with mock lace made with an inter-knitted nylon thread, which while looking attractive has a shorter life. Mock lace is fun. Real lace is a treasure! Making it is a serious but pleasurable pastime.

Knitting lace by hand is a slow process. Using the lacemaker it is worked quickly by comparison, but it is still a delicate craft and is worked more slowly than ordinary machine knitting. Even allowing 1 row per minute (up to 200 sts.) the heirloom lace tablecloth could be worked in spare time of two hours per day, in a little more than a week. Its cost to make is approx. £2.07. A square cloth with no shaping could be made more quickly but the design here is intended for experienced knitters who want to make something lasting and lovely and are prepared to spend a little extra time on it.

Helpful Hints

1. For the delicate pattern chosen for the Heirloom Tablecloth, the lace carriage has to be pushed twice in the **same** direction on most rows. We recommend lifting the carriage off between movements, (this soon becomes a habit) otherwise it tends to get in the way of the main carriage on this particular pattern.

2. A small table or stool by one's side is useful for resting the lace carriage on while knitting across with the main carriage.

3. When using the needle selector and set-lever, always push back the first two or last two needles when these come into operation, to keep a neat edge.

4. Every row should be glanced along in case of a dropped st. because on a pattern as delicate as this a mistake is best put right immediately. A single dropped st. can be held in place with a tiny safety pin and sewn in when the work is complete.

5. If it should be necessary to remove the work from the machine for any reason, before replacing, spray or dip in starch and press to prevent unravelling.

Undo to the easiest row for replacing on the machine.

On the easy-to-read pattern instructions this will be either row 13 or 15 of the pattern. (These are the equivalent of 'knit 2 together make one' all along the row.) Run a piece of sewing cotton along the sts. to hold them and replace on the correct needles.

To find the correct needles it will be noticed that two sts. are moved on nearly every row in each group of eight. These form a zig-zag throughout the fabric. On row 13 this zig-zag is placed on needle 8 and on row 15 it is on needle 7.

6. Weights are needed for this work and we found that satisfactory results were obtained by hanging the cast on comb into the lace mesh of a row 14 or 16 of the pattern, and hanging the two lacemaker



weights on the comb. As the work proceeds the weighted comb can be moved up.
7. On the unshaped section of knitting, a firmer edge can be obtained by undoing the

last st. of every row. This gives the same effect as slipping the first st. in hand knitting and is recommended to the perfectionist when making heirloom lace.

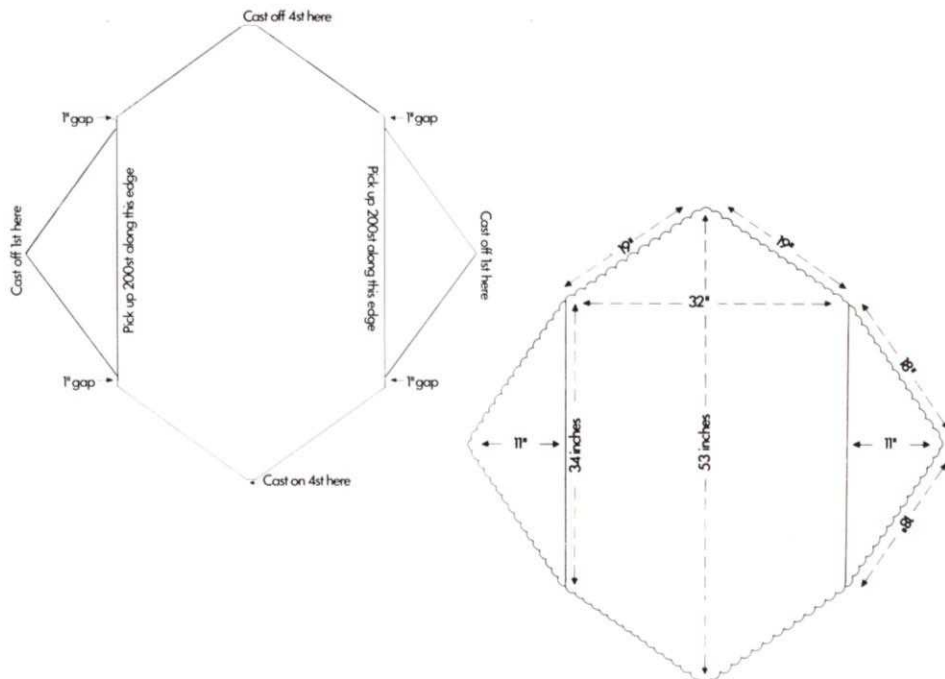

Instructions for Jones Lacemaker Knitting Machine
Materials

9 balls Coats Mercer Crochet Cotton size 20 in White.

Measurements

See Diagram. (The cloth was designed to fit a table approx. 30 ins. by 50 ins., but would look equally attractive on a square or round table within its dimensions.)

Tension and Machine Setting

Refer to Pattern Instructions for the lace design.

Cast on 4 sts. at centre of machine and K. 1 row. Increase 1 st. at each end of next 6 rows (K. 16 sts.). Begin working in pattern and at the same time cast on 8 sts. at beg. of next 2 rows (32 sts.). (* See special notes.) When increasing the groups of sts. cast these on by hand after using set-lever. K. across slowly. Hang claw weight on the new sts. instead of on cast-on comb. Do not include patterning for these new sts. until several rows have been worked—simply push back unwanted needles when using set-level. It may be a help to hold work in place by putting a strip of sellotape across the fabric just before casting on the extra sts., but do watch that no sts. are dropped before removing tape—on a lacy pattern a large hole can form because the work is weighted and stretched while on the machine. (Prevention is easier than cure!) The work will proceed more quickly when the increasings are complete. Decreasing provides no problems at all. Continue in pattern casting on 8 sts. at beg. of every 8th and 9th row of knitting until there are 192 sts. on machine. (If using easy-to-read pattern instructions the 8 sts. will be increased on pattern rows numbered 1, 2, 9 and 10.) (Row counter: 95 rows.) (For firm edge see special notes.) K. 328 rows in pattern without shaping. (Row counter: 423 rows.) **Cast off** 8 sts. at beg. of next 2 rows. Continue in pattern casting off 8 sts. at beg. of every 8th and 9th row of knitting until 16 sts. remain. **Cast off** 1 st. at each end of next 6 rows. **Cast off** remaining 4 sts.

To work the other two corners of Tablecloth
 Find centre of unshaped edge of cloth.

Place this on centre needles of machine making sure purl side of work is facing. **Pick up 200 sts.** along the edge. Arrange them evenly using centre st. as a guide. Leave 1 in. of fabric over at each end to keep the scalloped edging effect continuous to match the two corners already worked. With main carriage at the left, K. across these 200 sts. once. Work in pattern, casting off 8 sts. at beg. of every 8th and 9th row of knitting. (If using easy-to-read pattern instructions the 8 sts. will be decreased on pattern rows numbered 8, 9, 16 and 1.) Continue until there are 24 sts. left. Work 7 more rows in pattern. Cast off 6 sts. at beg. of next 2 rows. Cast off 1 st. at each end of every row until 2 sts. remain. K. 2 together, cast off remaining st.

Work other side to match

Sew in loose ends neatly. Starch lace well. Press into shape. If desired small loops can be crocheted around the edge of the cloth as follows: 1 double crochet into edge, 6 chain. Repeat all the way round using a very fine crochet hook.

Tension when starched and pressed

32 stitches to 5 ins.

5 patterns to 8 ins.

(N.B. On lace, some rows are made up of large holes and some of closer knitting and therefore this tension of 80 rows to 8 ins. cannot be reduced to 10 rows to 1 in.)

Easy-to-read pattern instructions for knitters without the pattern manual.

Most rows of this pattern have two movements of the lace carriage in the same direction, the first moves sts. along ready to knit-two-together, and the second movement fills in the empty needle by moving the next st. along. The new empty needle is filled when the row is knitted. An analysis of the pattern shows that it is the same two sts. zig-zagging that create the leafy pattern. If one should drop a st., this analysis should help when replacing it. (See special notes.) T5. Both H.C.L. 1. Reverse knob A. Slide dial 1. (These remain the same throughout.) Begin pattern with carriage at the right. There are five instructions for most rows, as follows:

	1. Press Needle Selector Button	2. Move Lace Carriage	3. Press Needle Selector Button	4. Move Lace Carriage	5. Move Carriage	
Row 1	7	←	8	←	←	Row 1
Row 2	6	←	7	←	→	Row 2
Row 3	5	←	6	←	←	Row 3
Row 4	4	←	5	←	→	Row 4
Row 5	3	←	4	←	←	Row 5
Row 6	none		none		→	Row 6
Row 7	2	→	1	→	←	Row 7
Row 8	3	→	2	→	→	Row 8
Row 9	4	→	3	→	←	Row 9
Row 10	5	→	4	→	→	Row 10
Row 11	6	→	5	→	←	Row 11
Row 12	none		none		→	Row 12
Row 13	1 3 5 7	→	none		←	Row 13
Row 14	none		none		→	Row 14
Row 15	2 4 6 8	←	none		←	Row 15
Row 16	none		none		→	Row 16

The Jones HOME KNITTING POSTAL TUITION COURSE for 585, 588 & 800 machines

is so easy to follow and the complete answer to all shortcomings encountered in the tuition of knitting machines. There are twelve easy to follow lessons, leading you step by step from basic knitting right through to knitwear design. You will be able to learn to knit at your own pace with nobody looking over your shoulder or hurrying you on to the next step. You can take out the machine and pick up the course exactly when you feel like it and all in the comfort of your own home. Should you require help you can write and ask the experts who are always there. Later you may wish to refresh your memory on certain points and of course the lessons are always there for you to refer to.



£12.50

inc. £3.00 of wool

Postal Tuition courses for the

KNITLEADER & RIBBER

are also available at

£1.50 each

rainbow polo neck jumper

Materials

10 (11, 13, 15) 25 grms. balls Sirdar Multi 4 ply.

Measurements

To fit chest 28 (30, 32, 34) ins.

Length to back neck 19 (20½, 22, 23½) ins.

Sleeve seam 13 (14½, 16, 17½) ins.

Tension

T7. 15 sts. and 20 rows to 2 ins.

Abbreviations

Sts., stitches; inc., increase; dec., decrease; alt., alternate; foll., following; rem., remaining; beg., beginning; H.C.L.'s., holding cam levers; T., tension; f.f., fully fashioned—place 3rd and 4th sts. onto 5th and 6th needles, move end 2 sts. in to close gap; 000, set row counter to 000.

BACK

Bring forward 105 (113, 121, 129) needles to working position. Push back every 3rd needle for 2 x 1 rib. ** Cast on in waste wool and work approx. 10 rows. T5. Using main yarn K. 42 rows rib; knitting centre 2 rows loosely for fold. Pick up the first row of loops in main yarn and place 2 onto each empty needle. K. 2 rows on all needles. **. 000. T7. K. straight until 96 (106, 116, 126) rows worked.

Raglan Shaping

000. Cast off 3 sts. at beg. of next 2 rows. K. 4 rows. Dec. 2 sts. f.f. at each end of next and every foll. 4th row until 35 (39, 39, 41) sts. rem. K. 1 row. Cast off.

FRONT

K. as back until 46 (52, 60, 68) rows have been worked from beg. of raglan shaping. Carriage at right and H.C.L.'s buttons on III. Slip centre 17 (21, 21, 19) sts. onto a st. holder. Push sts. to left into holding position and K. on right set of sts. Continue raglan shaping as before. At same time dec. 1 st. at neck edge on every alt. row 8 times in all. 5 sts. rem. K. 2 rows. Dec. once more at raglan edge only. Cast off. H.C.L.'s buttons onto I. Work other side to match.

SLEEVES

Bring forward 55 (57, 59, 61) needles into working position and push back every 3rd needle for 2 x 1 rib. K. as back from ** to **. 000. T7. K. 10 rows. Inc. 1 st. each end of next and every foll. 8th row until there are 75 (81, 87, 93) sts. Work straight until 110 (126, 140, 156) rows worked.

Raglan Shaping

Work as given for back until 11 (13, 13, 15) sts. rem. Dec. 1 st. f.f. at each end of last row where necessary. K. 1 row. Cast off.

POLO NECK (st. side, raglan and sleeve seams except left raglan)

With wrong side facing pick up 11 (13, 13, 15) sts. from 1st sleeve, 15 sts. down left neck, 17 (21, 21, 25) sts. across centre front, 15 sts. up right neck, 11 (13, 13, 15) sts. from 2nd sleeve and 33 (37, 37, 39) sts. from back neck. K. 2 rows on all needles. Transfer every 3rd st. for 2 x 1 Mock Rib. T5. K. 40 rows. T6. K. 18 (24, 24, 30) rows. T5. K. 20 rows. K. 2 rows on all needles 102 (114, 114, 126) sts. in all. Cast off loosely.

TO MAKE UP

Press with a warm iron over a damp cloth. Sew raglan, side and sleeve seams. Fold collar to inside and slip-st. Press seams.



PATTERNS PATTERNS PATTERNS

from Jones the knitting
machine people

Here's the new style pattern service from Jones - superb collections of garments presented in attractive booklet form, each booklet containing a series of garments for one section of your family.



Booklet 1: features ribbed garments. 2: general family garments. 3: toddlers' garments. 4: garments for children. 5: garments for ladies. 6: garments for men.



AND NOW TWO MORE ADDITIONS TO THE RANGE - Booklet 7: features garments from the very popular magazine "HOME SEWING AND KNITTING" and Booklet 8: a series of simple and basic patterns.



Each booklet is only 25p including postage and packing and can either be obtained from your local Jones stockist or direct from Jones Sewing Machine Co. Ltd, Audenshaw, Manchester.



Start collecting the set now - they'll give you many hours of enjoyable knitting and super garments for all your family.



Jones Jones Sewing Machine Co. Ltd.,
Britannia House, 964 High Road, Finchley, London, N.12