

stitchin' time

Vol 5 No 3

25p



Jones/brother

contents

Cable Sweater	3-4
Man's T-Shirt	4-5
Summer Jumper	6
Toddler's Outfit	7-8
Ladies Dressing Gown	8-9
Man's Sweater in Mock Rib	10-11
Ladies Jacket	11-12
Child's Fair-Isle Cardigan and Hat	12-13
Jacquard Top Dress	14-16
Six Design Set	17-21
Pattern Cardigan	22-23
Man's Cotton Shirt	23-24
Ladies Jumper	24-25
Man's Cotton Sweater	26
Mother and Daughter's Cardigans	27-28
Fuller Figure Cardigan	29-30
Man's Sweater	30-32
Ladies Sleeveless Jacket	32-33
Pram Set	33-34
Ladies Tabard	35

broadly speaking

After our previous magazine where we asked you to write in, we had several very interesting letters, but unfortunately they were too late to be included in this particular issue. We will be including a selection of them in the next issue and intend to give a prize of one year's subscription to the letter we consider to be the best. There is still time to include more letters, so if you have an interesting story, helpful hint, or just a funny tale concerning your knitting machine—drop us a line.

In recent months there has been a growing demand for people who can use the model 588 or the model 800 sufficiently well to knit fashion garments and we are proposing to prepare an index of people who are prepared to knit to make money and a corresponding index of companies and individuals who require knitters. If you wish to go on this index, please let us know the model machine you have, your name and address in block capitals and your telephone number if any and how much work per week you are prepared to do. We cannot in any way guarantee that work will be given, however, with knitwear being high fashion as it is and a large number of small designers setting up on their own, we are sure for anyone who can produce quality knitwear there will be a steady flow of work.

In our fashion format section you will notice that we have included a set of 6 designs all of which are based on the same basic shape but the neck lines and sleeve shapes vary. We hope these patterns are liked and are not too complex for you to follow. In response to demands for slightly more fashionable garments in the magazine (we are not going to get too trendy), we are thinking of taking on two young designers and their patterns will be printed in the new form i.e. with the bare minimum of instructions and mainly diagrams.

Although most of the patterns are adapted to both machines, occasionally a designer who does not know the conversion, writes patterns merely for either the model 800 or the earlier models and therefore if this occurs, please check with the chart below to find the correct settings for your H.C.L.'s.

800 H.C.L. 3 = I for all others
 800 H.C.L. 1 = II for all others
 800 H.C.L. 2 = III for all others.

N.B. CHARTS SUBMITTED BY DESIGNERS VARY DEPENDING ON WHICH MACHINE THE DESIGNER HAS USED. MOST PATTERNS USING EIGHT BUTTONS CAN BE DONE ON EITHER THE 588 OR THE 585. THE DIFFERENCES ARE

588	585
REVERSE LEVER+	REVERSE DIAL A
REVERSE LEVER-	REVERSE DIAL B

SUBSCRIPTION RATES FOR U.S.A. AND CANADIAN MEMBERS \$6.00.

These rates include postage.

cable sweater

Materials

14 (15, 16, 17) ozs. Emu Scotch 4 ply wool.

Measurements

To fit bust sizes 32 (34, 36, 38) ins.

Length to shoulder $23\frac{1}{4}$ ($23\frac{1}{2}$, $23\frac{3}{4}$, 24) ins.

Sleeve seam $17\frac{1}{2}$ ins.

Tension

T6. $15\frac{1}{2}$ sts. and 21 rows to 2 ins. over st.st.

Abbreviations

K., knit; sts., stitches; inc., increase; dec., decrease; alt., alternate; foll., following; beg., beginning; rem., remain; M.B., main bed; H.C.L's., holding cam levers; T., tension; 000., set row counter at 000.

Cable pattern

K. 8 rows. Cross sts. 1, 2 and 3 over 4, 5 and 6.

Notes

When dec. and shaping count needles in A position as one st.

BACK

Ribbers Cast on 131 (139, 147, 155) sts. as 1 x 1 rib. T3/3. K. 20 rows. Transfer ribber sts. to M.B.

Single machines Using waste wool, cast on 66 (70, 74, 78) sts. on alt. needles. K. a few rows. Change to main wool. T4. K. 39 rows. Make a hem and K. the row. *

All machines 000. T6. K. straight to 152 rows. Adjust length here if required.

Shape Armhole

000. Cast off 5 sts. at beg. of next 2 rows. Dec. 1 st. at each end of next 5 (7, 7, 9) rows then every alt. row 5 (4, 5, 4) times. 101 (107, 113, 119) sts. rem. * *. K. straight to 72 (74, 76, 78) rows.

Shape Shoulder

Cast off 6 (6, 7, 7) sts. at beg. of next 8 rows, and 6 (8, 6, 8) sts. at beg. of next 2 rows. Slip rem. 41 (43, 45, 47) sts. on to a knitting needle.

FRONT

K. as back to *. Arrange needles for cables. Counting from the centre transfer the 2nd and foll. 7th st. (both sides) on to adjacent needles. Counting from each side transfer the 23rd (24th, 25th, 26th) st. and foll. 7th, 10th and 17th st. on to adjacent needles. Push empty needles to A position. Foll. cable pattern K. as back to * *. K. straight to 48 (50, 52, 54) rows.

Shape Neck

Cast off centre 21 (23, 25, 27) sts. Push needles at left to E position. H.C.L's III. K. right side first. Dec. 1 st. at neck edge on next 5 rows, and foll. alt. rows 5 times. 30 (32, 34, 36) sts. rem. K. straight to 72 (74, 76, 78) rows.

Shape Shoulder

Cast off 6 (6, 7, 7) sts. at beg. of next and foll. alt. row 4 times in all. K. 1 row. Cast off rem. 6 (8, 6, 8) sts. H.C.L's I. K. left side to match reversing all shapings.

SLEEVES

Ribbers Cast on 61 (65, 69, 73) sts. as 1 x 1 rib. T3/3. K. 20 rows. Transfer ribber sts. to M.B.

Single machines Using waste wool cast on 31 (33, 35, 37) sts. on alt. needles. K. a few rows. Change to main wool. T4. K. 39 rows. Make a hem and K. the row.

All machines Arrange needles for centre cable panel as on Front. 000. T6. K. 8 rows.



mans t-shirt

Inc. 1 st. at each end of next and every foll. 9th row 16 times in all. 93 (97, 101, 105) sts. K. straight to 162 rows. (Adjust length here if required.)

Shape Top

000. Cast off 5 sts. at beg. of next 2 rows. Dec. 1 st. at each end of next 3 (5, 5, 5) rows then foll. alt. row 5 (4, 4, 4) times. K. 3 rows. Dec. 1 st. at each end of next and foll. 4th row 3 times in all, then every alt. row 4 (5, 6, 6) times. Dec. 1 st. at each end of next 7 (7, 5, 7) rows. Cast off 3 sts. at beg. of next 6 (6, 8, 8) rows. Cast off rem. 21 sts.

NECKBAND

With wrong side facing and beg. at right, place on machine 41 (43, 45, 47) sts. from back neck, pick up 30 sts. down front neck, 21 (23, 25, 27) sts. from centre and 30 sts. up front neck. 122 (126, 130, 134) sts. T6. K. 1 row.

Ribbers Transfer alt. sts. to ribber. T3/3. K. 20 rows. K. 1 loose row. Transfer ribber sts. to M.B. Cast off chain method.

Single machines Transfer alt. sts. to adjacent needles and push empty needles to A position. T4. K. 20 rows. Bring empty needles to B position. K. 1 loose row and cast off chain method.

TO MAKE UP

Pin out and press with a hot iron over a damp cloth. Join shoulder seams. Sew in sleeves, then join side and sleeve seams. Fold neck band to inside and slip-st. in place. Press seams.

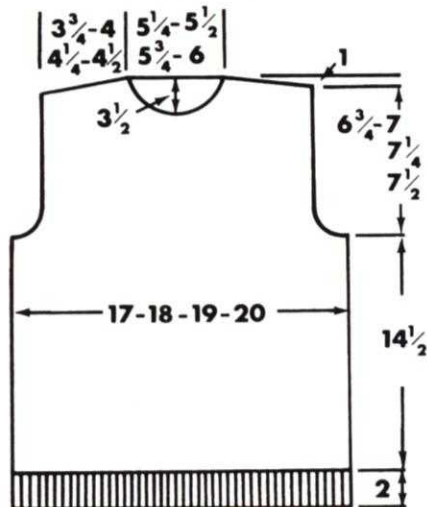
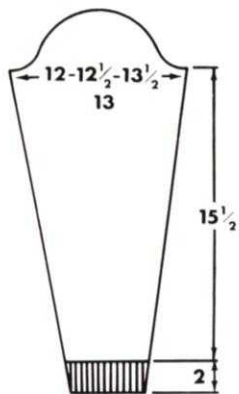

Materials

Striped T. Shirt 7 (8, 9, 10) ozs. Listers Lavenda 4 ply in M. 4 (4, 5, 5) ozs. Listers Lavenda 4 ply in A. 4 (4, 5, 5) ozs. Listers Lavenda 4 ply in B. Allow 1 oz. extra in M. for collar.

Plain T. Shirt 14 (16, 17, 19) ozs. in M. 1 button Crochet Hook. Allow 1 oz. extra for collar.

Measurements

To fit chest sizes 36 (38, 40, 42) ins. Length to back neck 26 (26 1/2, 27, 27 1/2) ins. Sleeve seam 4 1/2 ins.

Tension

T6. 15 sts. and 20 rows to 2 ins.

Abbreviations

K., knit; sts., stitches; dec., decrease; inc., increase; beg., beginning; alt., alternate; foll., following; rem., remain; H.C.L's., holding cam levers; 000., set row counter at 000; T., tension; M.B., main bed.

Notes

For striped garment please knit stripes throughout as follows: M 2 rows. A 2 rows. M 4 rows. B 2 rows. M 2 rows. A 4 rows. M 2 rows. B 2 rows. M 4 rows. A 2 rows. M 2 rows. B 4 rows (32 rows). Fully fashioning at raglan edges is worked by transferring the 4th st. onto 5th needle and moving end sts. 1 needle in.

SHIRT WITH ROUND NECK

BACK

Ribbers With M wool cast on 135 (143, 151, 159) sts. for 1 x 1 rib. T4/4. K. 20 rows. Transfer ribber sts. to M.B.

Single machines With waste wool cast on 68 (72, 76, 80) sts. over alt. needles. K. a few rows. Change to M. T4. K. 39 rows. Make a hem and K. the row. 135 (143, 151, 159) sts.

All machines 000. T6. K. 144 rows.

Shape Raglan

000. Cast off 4 sts. at beg. of next 2 rows. K. 2 rows. Dec. 1 st. (see notes) each end of next and foll. 4th rows 5 times in all * Then on every alt. row until 45 (47, 49, 51) sts. rem. K. 1 row. Slip sts. onto a knitting needle. For shirt with collar cast off sts.

FRONT

K. as back to * K. 1 row. Dec. 1 st. each end of next and foll. alt. row until 62 (68, 74, 80) rows have been worked.

Shape Neck

Cast off centre 21 (23, 25, 27) sts. Push sts. at left to E pos. H.C.L's III. ** Continue to dec. at raglan as before at the same time dec. 1 st. at neck edge on next and foll. alt. rows 10 times in all. Keep neck edge straight and dec. at raglan edge until 2 sts. rem. Cast off. H.C.L's I. K. to match right side

reversing all shapings.

SLEEVES

Ribbers With M wool cast on 87 (91, 95, 99) sts. for 1 x 1 rib. T4/4. K. 14 rows. Trans. ribber sts. to M.B.

Single machines With waste wool cast on 44 (46, 48, 50) sts. over alt. needles. K. a few rows. Change to M. T4. K. 27 rows. Make a hem and K. the row. 87 (91, 95, 99) sts.

All machines 000. T6. K. 8 rows. Inc. 1 st. each end of next and foll. 4th row 9 times in all. 105 (109, 113, 117) sts. K. straight to 48 rows.

Shape Raglan

000. Cast off 4 sts. at beg. of next 2 rows. K. 2 rows. Dec. 1 st. each end of next and foll. 4th row 6 (7, 8, 9) times in all, then on every foll. alt. row until 17 sts. rem. K. 1 row. Slip sts. onto a knitting needle. For shirt with collar cast off sts.

NECKBAND

With wrong side facing pick up and place on machine 45 (47, 49, 51) sts. from back neck, 17 sts. from 1st. sleeve. 69 (71, 73, 75) sts. from front neck, 17 sts. from 2nd sleeve 148 (152, 156, 160) sts. T6. K. 1 row.

Ribbers Trans. alt. sts. to ribber for 1 x 1 rib. T4/4. K. 20 rows. K. 1 row. T10/8. Trans. ribber sts. to M.B. Cast off chain method.

Single machines Trans. alt. sts. to adjacent needles. Return empty needles to A. pos. T4. K. 20 rows. Bring needles in A. pos. back to B. pos. T10. K. 1 row. Chain cast off.

TO MAKE UP

Pin out and press with a warm iron over a damp cloth. Join raglan, side and sleeve seams. Turn neckband to inside and slip-st. in place. Press seams.

SHIRT WITH COLLAR

BACK AND SLEEVES

K. as given for Back and sleeves of round neck shirt.

FRONT

K. as back to * K. 1 row.

Divide For Front Opening

Trans. centre st. to adjacent needle. Push sts. at left to E pos. H.C.L's III. Dec. 1 st. at raglan edge on next and foll. alt. row until 61 (67, 73, 79) rows have been worked. (K. 1 row extra for left side.)

Shape Neck

Cast off 10 (11, 12, 13) sts. at beg. of next row. Work as round neck from ** to end. H.C.L's I. K. to match right side reversing shapings.

COLLAR

000. T4. With M cast on 139 (143, 147, 151) sts. by hand. K. 2 rows. H.C.L's II. Always winding wool round first needle in E pos. * Push 8 (8, 9, 9) needles at opposite end to carriage to E pos. on next 10 rows. Return all needles at opposite end to carriage to C pos. on next 2 rows. * T5. K. 30 rows. T9. K. 1 row. T5. K. 30 rows. T4. K. from * to * K. 2 rows. Cast off loosely.

TO MAKE UP

As round neck. Join narrow ends of collar. Sew shaped edge to neck. Work 1 row of double crochet round neck opening making a loop at neck edge on one side. Sew on button. Press seams.

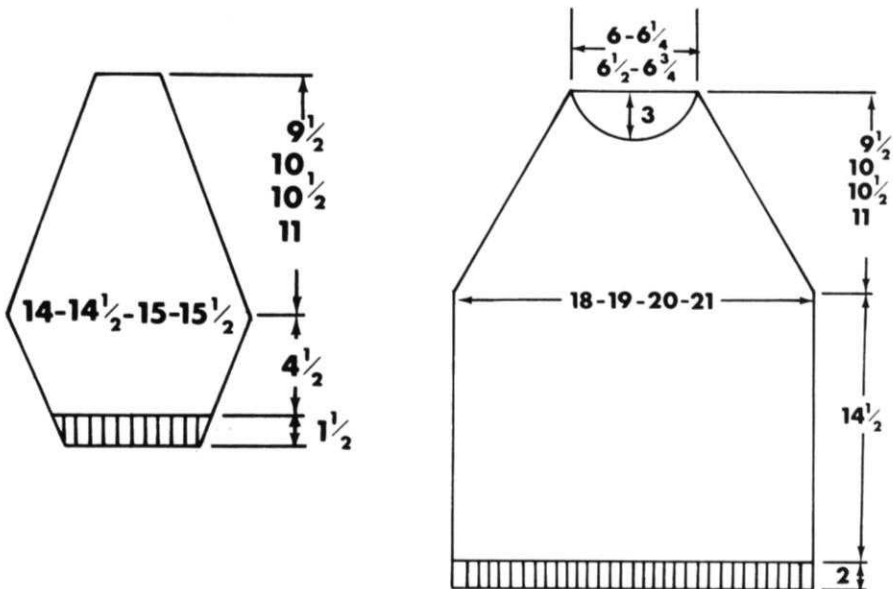

summer jumper

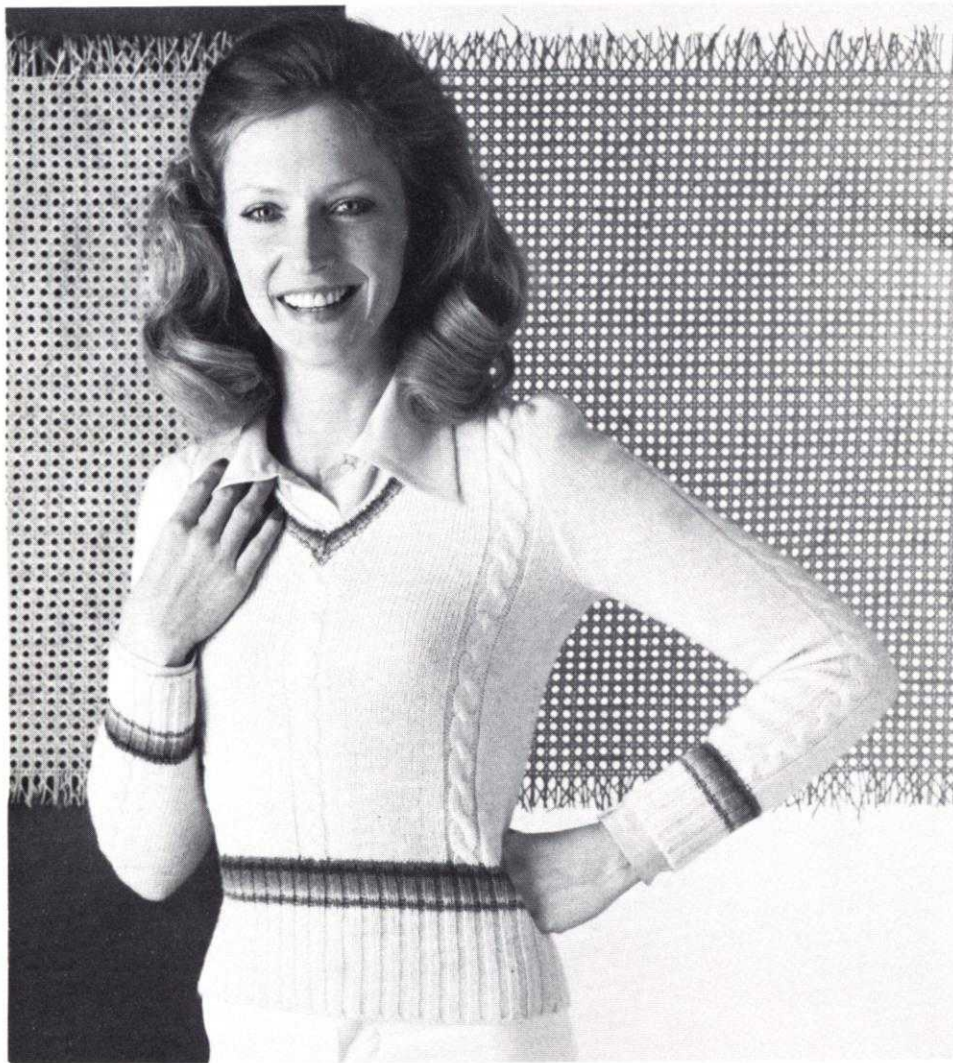

Materials

6 (7, 7) balls of Jaeger Gaelic Spun in main colour white; one ball in each of the following colours: juniper, clover, cherry, cornelia, cowslip, blackberry, cornflower.

Tension

7 sts. and 10 rows to 1 in.

Abbreviations

K., knit; p., purl; st., stitch; tog., together; dec., decrease; inc., increase; m., main colour.

Measurements

To fit bust sizes 32 (34, 36) ins.
All round at underarms 32 (34, 36) ins.
Side seam $13\frac{1}{2}$ ($13\frac{1}{2}$, $13\frac{1}{2}$) ins.
Length 21 ($21\frac{1}{2}$, $21\frac{1}{2}$) ins.
Sleeve seam 17 (17, 17) ins.

Note

The ribbing may also be worked by hand using a pair of No. 13 knitting needles or by using a single bed machine and dropping every 3rd and 4th st. to pick up with the latch tool to turn to K. sts.

BACK

With m. cast on 104 (112, 120) sts. for 2 x 2 rib. Set tension 3 sizes finer than main tension.
Work 40 rows in 2 x 2 rib.

* Continuing in rib work in stripes as follows: 2 rows juniper green, 2 rows cowslip yellow, 2 rows cornelian orange, 2 rows cherry red, 2 rows clover, 2 rows blackberry, 2 rows cornflower blue*.

Transfer sts. to 1 bed. Change to main tension. Set row counter at 000. Continue with m. only.

Work 5 rows straight.

Using the 3 x 3 transfer tool cable 6 sts. at centre of bed and the 31st to 36th sts. each side of centre. Work 5 rows.

The last 10 rows form the pattern; continuing as set inc. 1 st. at each end of the next row and the 3 following 20th rows to 112 (120, 128) sts.

Work 19 rows more to 90 rows on counter**

To shape the armholes: cast off 6 sts. at the beginning of the next 2 rows. Dec. 1 st. at each end of the next row and every alternate row 10 (12, 14) times in all to 80 (84, 88) sts.

Work 47 rows to 158 (162, 166) rows on counter. Drop 2 sts. at each side of cables and pick up with latch tool to form K. st. ridges.

To slope shoulders: cast off 7 sts. at beginning of next 4 rows and 5 (6, 7) sts. on the 2 following rows to 42 (44, 46) sts.

For back neckband: Transfer sts. to 2 beds for 2 x 2 rib. With green rib 1 row, with yellow rib 1 row, with orange rib 1 row, with red rib 1 row, with pink rib 1 row, with blackberry rib 1 row, with blue rib 1 row, with m. rib 2 rows, then cast off loosely.

FRONT

Work as for back to **. Divide sts. for neck: Next row: Slip 56 (60, 64) sts. at left onto a holder and continue on remaining 56 (60, 64) sts. for right front shoulder. The right front shoulder: To shape the armhole and to slope the neck: Cast off 6 sts. at the beginning and dec. 1 st. at end of next row. (1) Work 1 row straight, (2) Dec. at armhole edge on next row, (3) Dec. at neck edge on next row, (4) Dec. at armhole edge on next row, (5) Work 1 row straight, (6) Dec. at each end of next row.

Repeat last 6 rows twice (3 times) (3 times) then work the first 2 (1, 4) rows again. Continuing to dec. at neck edge on every 3rd row, work 40 (38, 38) rows more to 19 (20, 21) sts. and 151 (154, 157) rows on counter. Work 7 (8, 9) rows to 158 (162, 166) rows on counter. Drop 2 sts. at each side of cables, pick up with latch tool to form K., st. ridges.

To slope the shoulders: cast off 7 sts. at beginning of next row and following alternate row. On 5 (6, 7) sts. work 1 row, then cast off.

The left front shoulder: slip sts. from holder back onto 1 bed, rejoin yarn and work to end of row. Reset row counter at 90 and work as for right front shoulder to end.

SLEEVES (both alike)

With m. cast on 56 (60, 64) sts. for 2 x 2 rib. Set tension 3 places finer than main tension. Work 22 rows in 2 x 2 rib. Now work as far back from * to *. Transfer sts. to 1 bed. Change to main tension. Set row counter at 000. Working 6 st. cables at centre on every 10th row as for back continue as follows: Work 4 rows. Inc. 1 st. at each end of next row and every following 10th row 14 times in all to 84 (88, 92) sts.

Work 5 rows to 140 rows on counter. To shape sleeve top: cast off 5 (6, 7) sts. at beginning of next 2 rows. Dec. 1 st. at each end of next row and every following 4th row to 16 (17, 18) times in all 42 sts. Drop sts. each side of cable panel and using latch tool pick up sts. to form K. st. ridges. Cast off taking 3 sts. tog. all along the row.

LEFT AND RIGHT FRONT NECKBANDS (alike)

With right side of work facing loop up 56 (58, 60) sts. from one front edge. Position sts. on 2 beds for 2 x 2 rib. Working in rib in stripe sequence given for back neckband decrease 1 st. at centre front end on each row. Cast off loosely.

TO COMPLETE

Press with a warm iron over a damp cloth. Join shoulder seams, continuing across neckband. Set in sleeves. Join sleeve and side seams. Join row ends of neckband at centre front. Press seams.

toddlers outfit

Materials

Sweater

1 (2, 2) ozs. Emu 4 ply wool in colour A. 2 (3, 3) ozs. in colour B. 1 (2, 2) ozs. in colour C. 3 buttons.

Trousers

4 (5, 5) ozs. in colour A. Elastic to fit waist.

Hat

Allow ½ oz. in each colour.

Measurements

Sweater

To fit chest size 18 (20, 22) ins.

Finished measurements 20 (22, 24) ins.

Trousers

Inside leg seam 7½ (8½, 9½) ins.

Hat

To fit average size head.

Tension

T6. 11½ sts. and 31 rows to 2 ins.

Abbreviations

K., knit; sts., stitches; inc., increase; dec., decrease; alt., alternate; foll., following; rem., remain; beg., beginning; H.C.L's., holding cam levers; T., tension; 000., set row counter at 000; M.B., main bed.

SWEATER

BACK

Ribbers Using A. Cast on 57 (63, 69) sts. as 1 x 1 rib. T3/3 K. 10 rows. Transfer ribber sts. to M.B.

Single machines Using waste wool cast on 29 (32, 35) sts. on alt. needles. K. a few rows. Change to A T5. K. 19 rows. Make a hem and K. the row.

All machines 000. T6. Change to B. foll. chart K. to 62 (78, 94) rows.

Shape Raglan

000. Cast off 2 sts. at beg. of next 2 rows. K. 2 rows. * Dec. 1 st. at each end of next and every foll. 4th row 16 (18, 20) times in all, then every alt. row twice. 17 (19, 21) sts. rem. Using A. K. 1 row.

NECKBAND

Ribbers Transfer alt. sts. to ribber. T3/3. K. 8 rows. K. 1 loose row. Transfer ribber sts. to M.B. and cast off chain method.

Single machines Transfer alt. sts. to adjacent needles. Push empty needles to A position. T5. K. 16 rows. Return empty needles to B position. K. 1 loose row. Cast off chain method.

FRONT

K. as back to *. Cast off 5 sts. at centre. Push needles at left to E position. H.C.L's II. K. the right side first. Keeping neck edge straight dec. 1 st. at raglan edge on next and foll. 4th row 13 (15, 17) times. 11 (12, 13) sts. rem. Cast off 1 (2, 3) sts. at neck edge on next row then dec. 1 st. on every 4th row 3 times. **At the same time** continue to dec. at raglan edge as before 3 more times, then every alt. row twice. Cast off rem. 2 sts. H.C.L's I. Return needles at left to B position by hand. Rejoin wool at neck edge and K. to match right half.

SLEEVES

Ribbers Using A cast on 33 (35, 37) sts. as 1 x 1 rib. T3/3 K. 10 rows. Transfer ribber sts. to M.B.

Single machines Using waste wool. Cast on 17 (18, 19) sts. on alt. needles. K. a few rows. Change to A T5. K. 19 rows. Make a hem and K. the row.



All machines 000. T6. Foll. chart and working in stripes of 16 rows in each colour throughout. K. 12 rows. Inc. 1 st. at each end of next and foll. 12th row 4 (6, 8) times. 41 (47, 53) sts. K. straight to 64 (86, 110) rows.

Shape Raglan

000. Cast off 2 sts. at beg. of next 2 rows. K. 4 rows. Dec. 1 st. at each end of next and foll. 6th row 6 (4, 2) times then every 4th row 8 (13, 18) times in all. Slip rem. 9 sts. onto a knitting needle.

NECKBAND

With wrong side facing and beg. at left. Pick up 8 sts. up right front neck and 9 sts. from 1 sleeve (17 sts.). Using A K. 1 row.

Ribbers Transfer alt. sts. to ribber T3/3. K. 8 rows. K. 1 loose row. transfer ribber sts. to M.B. and cast off chain method.

Single machines Transfer alt. sts. to adjacent needles, push empty needles to A position. T5. K. 16 rows. Return empty needles to B position. K. 1 loose row and cast off chain method. K. left front to match.

BUTTONBAND

Join front raglan seams. Turn mock rib neckband to inside and slip-st. in place. With wrong side facing pick up 27 (30, 33) sts. from left front (right front for boys) and 9 sts. from neckband 36 (39, 42) sts. Using A K. 1 row.

Ribbers Transfer alt. sts. to ribber T3/3. K. 10 rows. K. 1 loose row. Transfer ribber sts. to M.B. and cast off chain method.

Single machines Transfer alt. sts. to adjacent needles. Push empty needles to A position. T5. K. 20 rows. Return empty needles to B position. K. 1 loose row and cast off chain method.

		1	2	3	4	5	6	7	8	9	10	11	12	STEPS	STEPS	1	2	3	4	5	6	7	8	SLIDE DIAL	CARRIAGE DIRECTION
↑														4	4										
↘		0	0	0	0	0	0	0	0	0	0	0	0	3	3	■	■	■	■	■	■	■	■	-	↑
↑														2	2										↑
↓		0	0	0	0	0	0	0	0	0	0	0	0	1	1	■	■	■	■	■	■	■	■	+	↑
K.C.	S.L.	1	2	3	4	5	6	7	8	9	10	11	12												
2	1	K.H.800 MACHINE LEFT TUCK BUTTON IN H.C.L.3														K.H.588 MACHINE LEFT TUCK BUTTON IN BOTH H.C.L.s1								1	2

ladies dressing gown

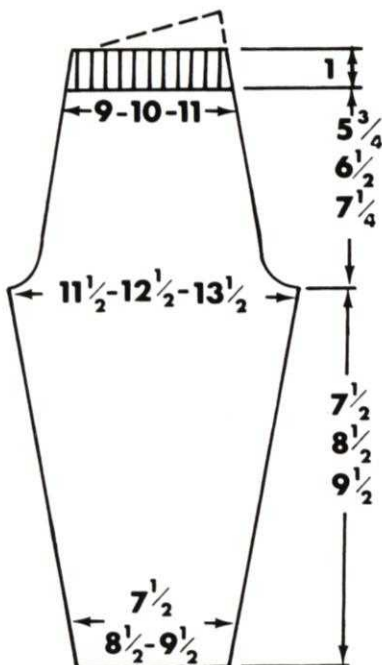
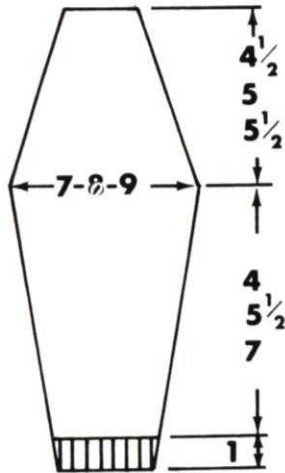
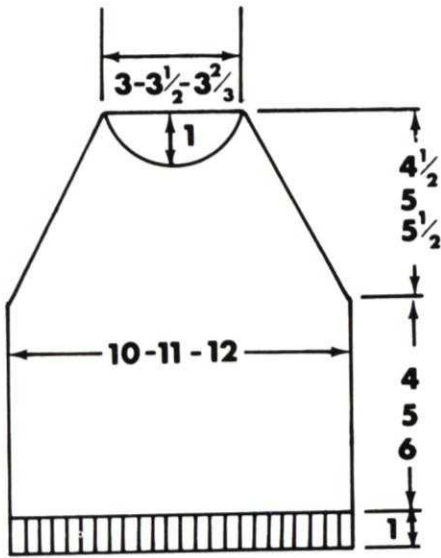

BUTTONHOLE BAND

Mark position on buttonband for 3 buttons. First to come in the middle of the neckband, the last $1\frac{1}{4}$ ins. above lower edge and the remaining one in the centre of these two.

Ribbers K. as buttonband making buttonholes on row 5 over 1 st.

Single machines K. as buttonband making buttonholes on rows 5 and 15 over 1 st.

TO MAKE UP

Pin out and press with a warm iron over a damp cloth. Join back raglan, side and sleeve seams. Fold mock rib front bands in half and slip-st. in place. Sew on buttons. Press seams.

TROUSERS

LEFT LEG

All machines Using A. Cast on 43 (49, 55) sts. by hand. T6. K. 10 rows. 000. T6. foll. chart K. 8 (9, 10) rows inc. 1 st. at each end of next and foll. 8th (9th, 10th) row 13 times in all 69 (75, 81) sts. K. straight to 116 (132, 148) rows. This will give a finished inside leg seam of $7\frac{1}{2}$ ($8\frac{1}{2}$, $9\frac{1}{2}$) ins.

Shape to Waist

000. Cast off 3 sts. at beg. of next 2 rows. K. 12 (14, 16) rows. Dec. 1 st. at each end of next and foll. 14th (16th, 18th) rows 6 times in all 51 (57, 63) sts. K. 2 rows. (K. 1 row extra for right front.) Carriage at left.

Shape Back

Push up 27 (33, 39) needles at opposite end to carriage to E position. H.C.L.'s II. Always winding wool round first needle in E position. K. 2 rows. Push up 4 needles at opposite end to E position on next and alt. rows 5 times in all. K. 1 row. H.C.L.'s I. K. 1 row in stocking st.

WAISTBAND

Transfer every 3rd st. to adjacent needle. Push empty needles to A position. T5. K. 20 rows. Return empty needles to B position K. 1 loose row. Cast off chain method.

RIGHT LEG

K. to match left leg, reversing back shaping.

TO MAKE UP

Pin out and press with a warm iron over a damp cloth. Join inner leg seams to crutch, then front and back seams. Turn lower edges and waistband to inside and slip-st. in place. Thread elastic through waistband. Press seams.

HAT

Ribbers Using A. Cast on 93 (97, 101) sts. as 1 x 1 rib. T3/3 K. 10 rows. Transfer ribber sts. to M.B.

Single machines Using waste wool cast on 47 (49, 51) sts. K. a few rows. Change to A T5. K. 19 rows. Make a hem and K. the row.

All machines 000. T6. Foll. chart and working in stripes of 16 rows in each colour. K. straight to 78 (86, 94) rows. Transfer every alt. st. to adjacent needle push empty needles to A position. K. 1 row. Slip sts. onto a No. 12 knitting needle. K. 2 together all along the row. Break wool leaving end long enough to thread through loops and sewing seam. Thread wool through loops.

TO MAKE UP

Pin out and press with a warm iron over a damp cloth. Draw up st. loops and join seam. Press seams. Make a pompon if required, and sew on hat.

Materials

20 (23, 25, 28, 30) balls Patons Baby Colourglow Quicknit. Edging for edges and cuffs.

Measurements

To fit bust sizes 34 (36, 38, 40, 42) ins. Finished measurements 36 (38, 40, 42, 44) ins.

Length to shoulder 40 ($40\frac{1}{2}$, $40\frac{1}{2}$, $40\frac{1}{2}$, 41) ins.

Sleeve seam 13 ins.

Tension

13 sts. and 20 rows to 2 ins. over lace pattern.

Abbreviations

K., knit; sts., stitches; inc., increase; dec., decrease; alt., alternate; foll., following; rem., remain; beg., beginning; H.C.L.'s., holding cam levers; T., tension; 000., set row counter at 0001

Notes

Dec. at neck edge are worked before pulling set lever by using the 2 sts. transfer tool. If either of the 2 end needles are selected return these to B position.

BACK

Using waste wool cast on 125 (131, 137, 143, 149) sts. K. a few rows. Change to main wool T6. K. 19 rows. Make a hem and K. the row. 000. T7. Foll. lace chart K. 20 rows. Dec. 1 st. at each end of next and foll. 10th row 20 times in all. 85 (91, 97, 103, 109) sts. K. to 236 rows. Inc. 1 st. at each end of next and foll. 6th row 13 times in all. 111 (117, 123, 129, 135) sts. K. straight to 320 rows.

Shape Armhole

000. Cast off 4 (4, 4, 5, 5) sts. at beg. of next 2 rows. Dec. 1 st. at each end of next 5 rows, then every alt. row 4 (5, 5, 5, 5) times. K. straight to 70 (72, 76, 80) rows.

Shape Shoulder

Cast off 5 (5, 5, 6, 6) sts. at beg. of next 8 rows and 5 (6, 8, 5, 7) sts. at beg. of next 2 rows. Cast off rem. 35 (37, 39, 41, 43) sts.

RIGHT FRONT

Using waste wool cast on 89 (93, 95, 99, 101) sts. having 42 sts. to left of centre and 47 (51, 53, 57, 59) sts. to right. K. a few rows. Change to main wool. T6. K. 19 rows. Make a hem and K. the row. 000. T7. Foll. lace chart K. 22 rows. Dec. 1 st. at right edge on next and foll. 10th row 20 times in all. 69 (73, 75, 79, 81) sts. K. to 236 rows.

Shape Front Edge

Dec. 1 st. at front edge on next and foll. alt. row 15 times in all, then every foll. 4th row, at the same time, inc. 1 st. at right edge on next and foll. 6th row 13 times in all. Keeping side edge straight, continue dec. at front edge. K. to 320 rows. (K. 1 row extra for left front.)

Shape Armhole

000. Cont. dec. at neck edge, cast off 4 (4, 4, 5, 5) sts. at beg. of next row. K. 1 row. Dec. 1 st. at armhole edge on next 5 rows, then every alt. row 4 (5, 5, 5, 5) times in all. Keeping armhole edge straight continue to dec. at neck edge until 25 (26, 28, 29, 31) sts. rem. K. to 70 (72, 76, 80) rows.

Shape Shoulder

Cast off 5 (5, 5, 6, 6) sts. at beg. of next and every alt. rows until 5 (6, 8, 5, 7) sts. rem. K.



1 row. Cast off.
LEFT FRONT

K. to match right front reversing all shapings and setting S.D. so that front edge (right side) matches right front.

SLEEVES

Using waste wool cast on 55 (59, 61, 65, 67) sts. K. a few rows. Change to main wool T6/1. K. 19 rows. Make a hem and K. the row. 000. T7. Foll. lace chart K. 10 rows. Inc. 1 st. at each end of next and foll. 9th row 12 times in all 79 (83, 85, 89, 91) sts. K. straight to 120 rows.

Shape Top

000. Cast off 4 (4, 4, 5, 5) sts. at beg. of next 2 rows. Dec. 1 st. at each end of next 3 rows. K. 3 rows. Dec. 1 st. at each end of next and foll. 4th row 5 (5, 6, 6, 6) times in all, then every alt. row 6 (6, 4, 5, 6) times. Dec. 1 st. at each end of next 5 (7, 9, 9, 9) rows. Cast off 3 sts. at beg. of next 4 rows. Cast off rem. 21 sts.

BELT (2 pieces alike)

Cast on 14 sts. by hand. T7. K. 160 rows. Cast off.

TO MAKE UP

Join shoulder seams. Set in sleeves. Join side and sleeve seams. Fold belt lengthways and slip-st. along seam. Work 1 row of double crochet up right front across back neck and down left front. Work 1 row of double crochet round cuffs. Sew on trimming round all edges and cuff. Sew one piece of belt to waist at left side seam and sew other piece to corresponding position on edge of right front. Sew a button to wrong side of side seam of right front and fasten with button loop at left front edge.

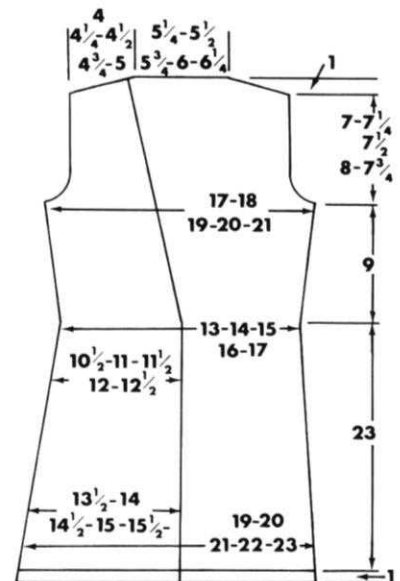
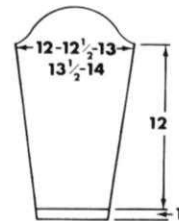

S.I.L.	K.C.	L.C.	S.L.	1	2	3	4	5	6	7	8	9	10	11	12	STEPS	STEPS	1	2	3	4	5	6	7	8	LACE CARRIAGE DIRECTION
																6	6									
																0	5									
I																4	4									
																3	3									
																2	2									
I																1	1									

K.H. 800 MACHINE
H.C.L.3

K.H. 588 MACHINE
BOTH H.C.L.s 1 R.L.+
SLIDEDIAL 2

mans sweater in mock rib

DBLE. KNITTING

Materials

15 (16, 17, 18, 19, 20) ozs. Robin Vogue Double Knitting wool.

Measurements

To fit chest sizes 36 (38, 40, 42, 44, 46) ins. Length to shoulder 24 (24½, 25, 25½, 26, 26½) ins.

Tension

T10. 13½ sts. and 16 rows to 2 ins. after pressing.

Abbreviations

K., knit; sts., stitches; inc., increase; dec., decrease; beg., beginning; alt., alternate; rem., remain; trans., transfer; pos., position; H.C.L's., holding cam levers; T., tension.

Notes

Needles in A pos. are counted as a stitch when shaping and measuring tension.

BACK

Using waste wool cast on 63 (66, 70, 73, 77, 80) sts. over alt. needles. K. a few rows. Change to main wool T7. K. 29 rows. Make a hem and K. the row. 125 (131, 139, 145, 153, 159) sts. Trans. centre and every foll. 8th st. out to each side to adjacent needle. Return empty needles to A pos. 000. T10. K. 100 rows.

Shape Armholes

000. Cast off 4 (4, 5, 5, 6, 6) sts. at beg. of next 2 rows. Dec. 1 st. each end of next 11 (13, 14, 16, 17, 18) times in all 95 (97, 101, 103, 107, 110) sts. * K. straight to 76 (80, 84, 88, 92, 96) rows.

Shape Shoulders

Cast off 7 (7, 7, 7, 8, 8) sts. at beg. of next 6 rows and 7 (7, 8, 8, 6, 7) sts. at beg. of next 2 rows. Arrange rem. 39 (41, 43, 45, 47, 49) sts. on alt. needles for mock rib. T7. K. 16 rows. T10. K. 1 row. Cast off making a chain over empty needles.

FRONT

K. as Back to *.

Divide for Neck

Push 47 (48, 50, 51, 53, 55) sts. at left of centre st. (needle in A pos.) to E pos. H.C.L's. III. K. right side first. K. 3 rows. Dec. 1 st. at neck edge on next and foll. 3rd row until 28 (28, 29, 29, 30, 31) sts. rem. K. straight to 76 (80, 84, 88, 92, 96) rows.

Shape Shoulder

Cast off 7 (7, 7, 7, 8, 8) sts. at beg. of next and foll. alt. row until 7 (7, 8, 8, 6, 7) sts. rem. K. 1 row. Cast off. K. left side to match reversing shapings.

NECKBAND

With wrong side facing pick up and place on machine 59 (61, 63, 65, 67, 69) sts. from down right neck. T10. K. 1 row. Trans. alt. sts. to adjacent needles for mock rib. T7. K. 8 rows, dec. 1 st. at V-neck on every alt. row, then, K. 8 rows. Inc. 1 st. at same side on every alt. row. T10. Cast off loosely making a chain over empty needles. K. left side to match.

ARMBANDS

Join shoulder seams. With wrong side facing pick up and place on machine 129 (135, 143, 149, 157, 165) sts. T10. K. 1 row. Trans. alt. sts. to adjacent needles for mock rib. T7. K. 16 rows. T10. K. 1 row. Cast off making a chain over empty needles.

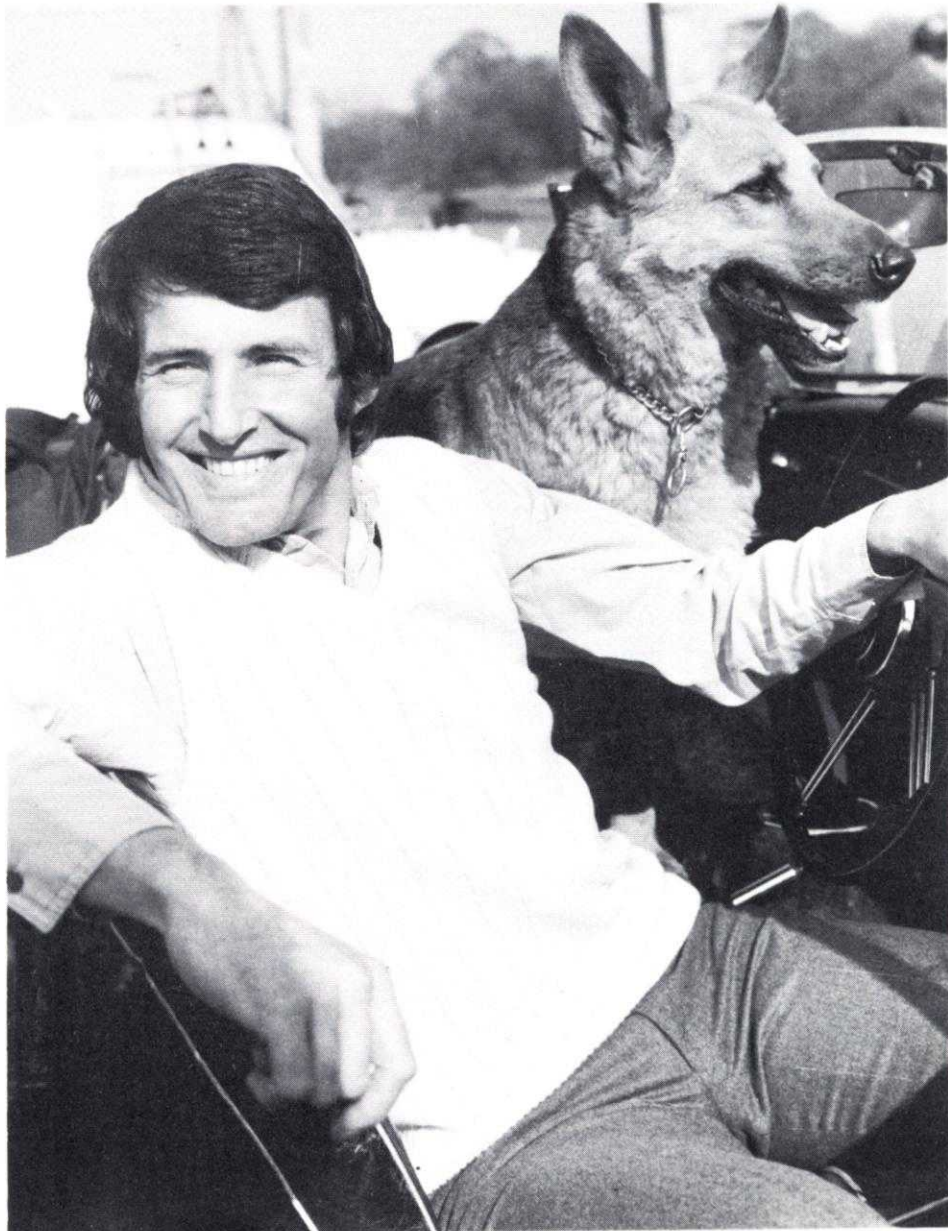

TO MAKE UP

Pin out and press with a warm iron over a damp cloth. Join mitred ends of front neck. Turn neckband and armbands to inside and slip stitch in place. Press seams.

4 PLY

Materials

9 (9, 10, 11, 12, 12) ozs. Robin Vogue 4 ply wool.

Measurements

To fit chest sizes 36 (38, 40, 42, 44, 46) ins. Length to shoulder 24 (24½, 25, 25½, 26, 26½) ins.

Tension

T6. 15 sts. and 20 rows to 2 ins. after pressing.

Abbreviations

K., knit; sts., stitches; inc., increase; dec., decrease; beg., beginning; alt., alternate;

rem., remain; trans., transfer; H.C.L's., holding cam levers; T., tension.

Notes

Needles in A position are counted as one stitch when shaping and measuring tension. Make a chain over empty needles when casting off.

BACK

Using waste wool cast on 69 (73, 77, 81, 85, 89) sts. over alt. needles. K. a few rows. Change to main wool. T4. K. 37 rows. Make hem and K. the row. 137 (145, 153, 161, 169, 177) sts. Trans. centre and every foll. 8th st. out to each side to adjacent needle. Return empty needles to A position. 000. T6. K. 124 rows.

Shape Armholes

000. Cast off 6 (6, 6, 8, 8, 8) sts. at beg. of next 2 rows. Dec. 1 st. each end of next 7 rows and foll. alt. rows 3 (5, 7, 7, 9, 11) times in all. 105 (109, 113, 117, 121, 125)

ladies jacket

sts. * K. straight to 96 (100, 106, 110, 116, 120) rows.

Shape Shoulders

Cast off 6 (6, 6, 7, 7, 7) sts. at beg. of next 8 rows and 6 (7, 8, 5, 6, 7) sts. at beg. of next 2 rows. 45 (47, 49, 51, 53, 55) sts. rem. Transfer alt. sts. to adjacent needles for mock rib T4. K. 19 rows. T10. K. 1 row. Cast off loosely making chain over empty needles.

FRONT

K. as back to * K. 1 row.

Divide for Neck

Push 52 (54, 56, 58, 60, 62) sts. at left of centre st. (needle is in A position) to E position. H.C.L's III. K. right side first. K. 3 rows. Dec. 1 st. at neck edge on next and foll. 3rd row until 30 (31, 32, 33, 34, 35) sts. rem. K. straight to 96 (100, 106, 110, 116, 120) rows.

Shape Shoulders

Cast off 6 (6, 6, 7, 7, 7) sts. at beg. of next and foll. alt. rows until 6 (7, 8, 5, 6, 7) sts. rem. K. 1 row. Cast off. K. left front to match reversing all shapings.

NECKBAND

With wrong side facing pick up and place on machine 67 (69, 71, 73, 75, 77) sts. down right front neck. T7. K. 1 row. Beg. at V. transfer alt. sts. to adjacent needles for mock rib. T4. K. 10 rows. Dec. 1 st. at neck edge on every alt. row, then K. 10 rows inc. 1 st. at same side on every alt. row. T10. K. 1 row. Cast off loosely making a chain over empty needles. K. other side to match.

ARMBANDS

Join shoulder seams. With wrong side facing pick up and place on machine 142 (150, 158, 166, 174, 182) sts. from round armhole K. 1 row. Trans. alt. sts. to adjacent needles. T4. K. 20 rows. Cast off loosely.

TO MAKE UP

Pin out and press with a warm iron over a damp cloth. Join side seams. Join mitre at V-neck. Turn neckband and armbands to wrong side and slip-st. in place. Press seams.

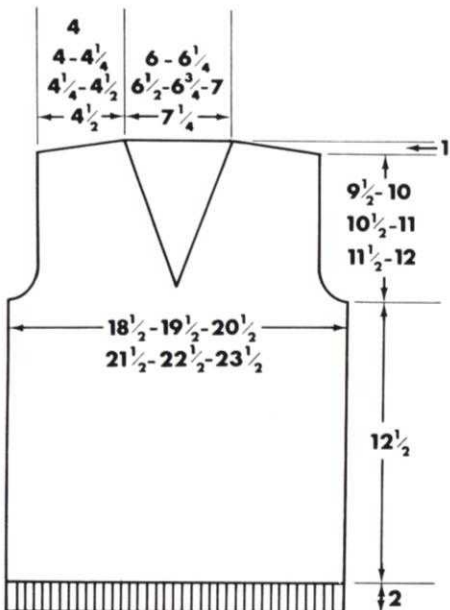
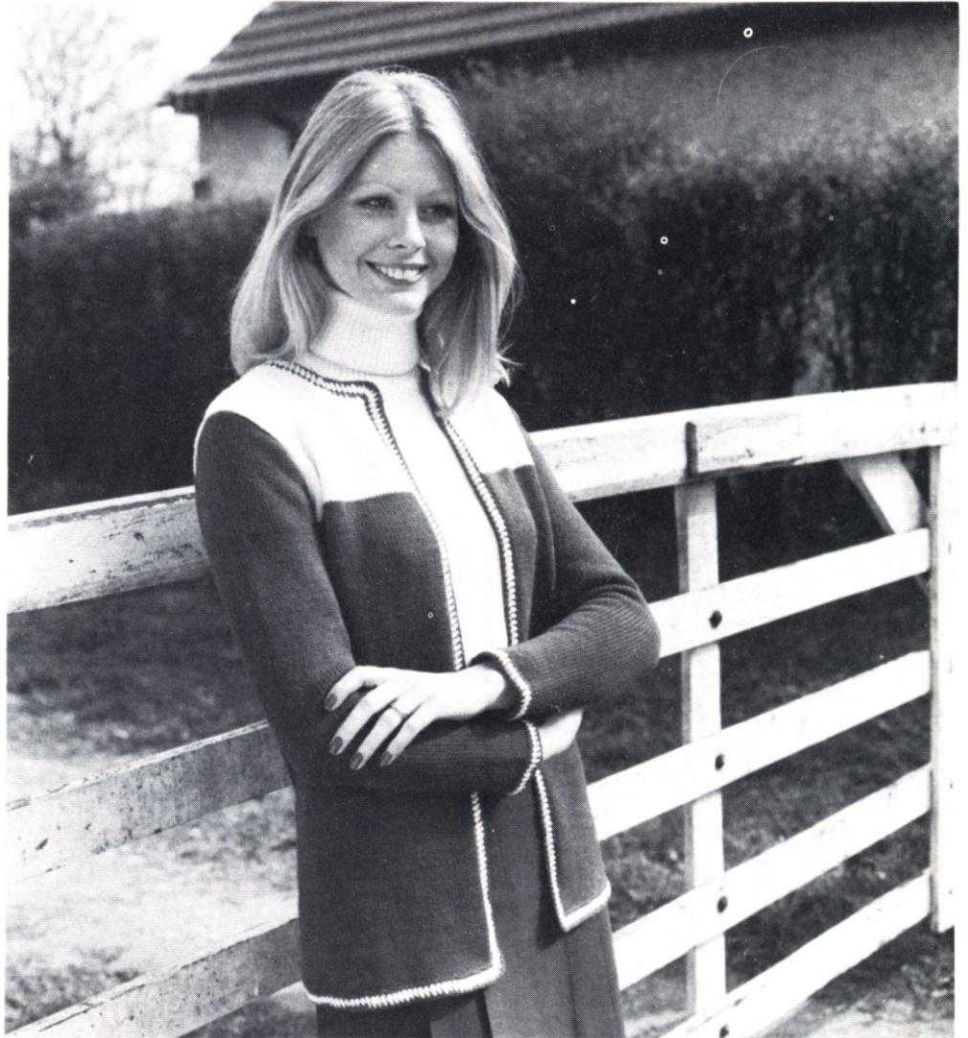

Materials

16 (18, 20) ozs. Robin Vogue Double Knitting in main colour. 4 (4, 5) ozs. in contrast. Crochet hook.

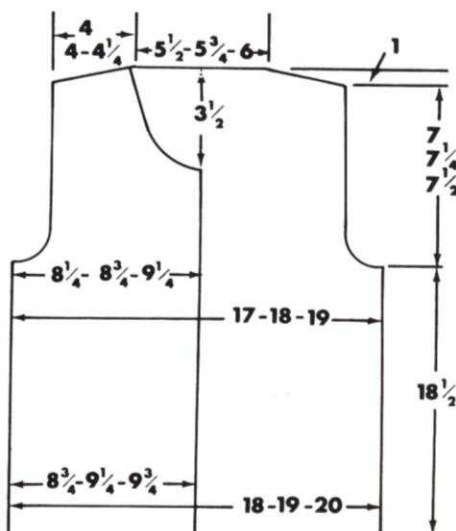

Measurements

To fit bust sizes 34 (36, 38) ins. Length to shoulder 26 (26 1/2, 26 1/2) ins. Sleeve seam 17 1/2 ins.

Tension

T10. 13 sts. and 16 rows to 2 ins.

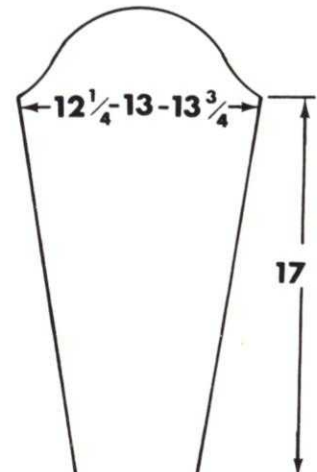

childs fair-isle cardigan & hat

Abbreviations

K., knit; sts., stitches; inc., increase; dec., decrease; alt., alternate; foll., following; beg., beginning; rem., remain; H.C.L's., holding cam levers; T., tension; 000., set row counter at 000.

BACK

Cast on 118 (124, 130) sts. by hand. 000. T10. K. 30 rows. Dec. 1 st. each end of next and foll. 30th row 3 times in all 112 (118, 124) sts. K. straight to 148 rows.

Shape Armholes

Change to contrast wool. 000. Cast off 6 sts. at beg. of next 2 rows. Dec. 1 st. each end of next 5 rows, then on foll. alt. rows until 84 (88, 92) sts. rem. K. straight to 56 (58, 60) rows.

Shape Shoulders

Cast off 6 sts. at beg. of next 6 rows and 7 (8, 9) sts. on foll. 2 rows. Cast off rem. 34 (36, 38) sts.

RIGHT FRONT

Cast on 57 (60, 63) sts. by hand. 000. T10. K. 30 rows. Dec. 1 st. at beg. of next and foll. 30th row 3 times in all 54 (57, 60) sts. K. straight to 131 rows. (1 extra row on left front.)

Shape Bust Darts H.C.L's III. Always winding wool round first needle in E position push 6 needles at opposite end to carriage to E position on next and foll. alt. rows 4 times in all. K. 1 row. H.C.L's I. K. a further 17 rows. (Carriage at right side.)

Shape Armholes

Change to contrast wool. 000. Cast off 6 sts. at beg. of next row. K. 1 row. Dec. 1 st. at armhole edge of next 5 rows, then on alt. rows until 40 (42, 44) sts. rem. K. straight to 37 (39, 41) rows.

Shape Neck

Cast off 7 (8, 9) sts. at beg. of next row. K. 1 row. Dec. 1 st. at neck edge of next and foll. alt. rows until 25 (26, 27) sts. rem. K. straight to 56 (58, 60) rows.

Shape Shoulder

Cast off 6 sts. at beg. of next and foll. alt. rows 3 times in all. K. 1 row. Cast off rem. 7 (8, 9) sts. K. left front to match reversing all shapings.

SLEEVES

Cast on 52 (54, 58) sts. by hand. 000. T10. K. 30 rows. Inc. 1 st. each end of next and foll. 7th (7th, 6th) rows 14 (15, 16) times in all 80 (84, 90) sts. K. straight to 136 rows. (Adjust length here if required.)

Shape Top

000. Cast off 6 sts. at beg. of next 2 rows. Dec. 1 st. each end of next 5 rows and foll. alt. rows 3 times. K. 3 rows. Dec. 1 st. each end of next and foll. 4th row 3 times in all 46 (50, 56) sts. Dec. 1 st. each end of next 6 (8, 11) rows. K. 1 row. Cast off 3 sts. at beg. of next 6 rows. Cast off rem. 16 sts.

TO MAKE UP

Pin out and press with a warm iron over a damp cloth. Join shoulder, side and sleeve seam. Set in sleeves. Using main colour work 1 row of double crochet along lower edge, up fronts and round neck. Change to contrast and work 1 row in treble, then 1 row in double crochet in main. Crochet 3 rows in the same way round cuff. Press seams.



Materials

6 (7, 8) ozs. Templetons Scotch Double Knitting, Brown. 5 (6, 6) ozs. Templetons Scotch Double Knitting, Orange. 5 (5, 6) ozs. Templetons Scotch Double Knitting, Yellow. 2 (2, 3) ozs. Templetons Scotch Double Knitting, White. 6 Buttons.

Measurements

To fit chest sizes 24 (26, 28) ins.
Actual measurement 26 (28, 30) ins.
Length to back neck 15½ (17½, 19½) ins.
Sleeve seam 12½ (14, 15½) ins.

Tension

T10. 14 sts. and 18 rows to 2 ins. (Check tension carefully.)

Abbreviations

K., knit; sts., stitches; inc., increase; dec., decrease; beg., beginning; alt., alternate; rem., remain; foll., following; M.B., main bed; T., tension; 000., set row counter at 000.

BACK

Ribbers With brown wool cast on 91 (97, 103) sts. as 1 x 1 rib. T7/6. K. 16 rows. Transfer ribber sts. to M.B.

Single machines With waste wool cast on 46 (49, 52) sts. over alt. needles. K. a few rows. Change to brown wool. T7. K. 31 rows. Make a hem and K. the row. 91 (97, 103) sts.

All machines 000. T10. * K. 1 row. Set machines for Fair-Isle (588 and 800 to M.C.) K. 1 row. Foll. Fair-Isle chart K. 62 (76, 90) rows *.

Shape Raglan

000. Cast off 2 sts. at beg. of next 2 rows. Dec. 1 st. each end of next and foll. alt. rows until 31 (33, 35) sts. rem. K. 1 row. Slip sts. onto a knitting pin.

RIGHT FRONT

Ribbers With brown wool cast on 42 (45, 48) sts. as 1 x 1 rib. T7/6. K. 16 rows.

For KH-588 and 800 machines

Materials

Dress 14 (15, 16) ozs. Lister Lavenda 4 ply.
Shade A. 4 (4, 5) ozs. Lister Lavenda 4 ply.
Shade B. 2 (2, 3) ozs. Lister Lavenda 4 ply.
Shade C. 2 (2, 3) ozs. Lister Lavenda 4 ply.
Shade D. 1 (1, 2) ozs. Lister Lavenda 4 ply.
Shade E. 24 (24, 26) ins. zip.

Waistcoat 4 (4, 5) ozs. Lister Lavenda 4 ply.
Shade A. 2 small buttons. Oddments of shades B and D for crochet edges.

Measurements

To fit 32 (34, 36) ins. bust.
Dress 34 (36, 38) ins. at underarm.
34 (36, 38) ins. at hips.
37½ (38, 38½) ins. length.
17 (17½, 18) ins. sleeve seam.

Waistcoat 34 (36, 38) ins. at underarm.
15 (15½, 16) ins. shoulder to hem.

Tension

7½ sts. and 10½ rows to 1 in. on T6.

Abbreviations

T., tension; COBH., cast on by hand over every needle; st(s), stitch(es); K., knit; MDE., make double edge by placing each loop at cast on edge onto needles in B position; COR(L), carriage on right or left; 000., set row counter to 000; dec., decrease; inc., increase; foll., following; fin., finishing; cont., continue; rep., repeat; beg., beginning; alt., alternate; rem., remaining; N., needle(s); patt., pattern; pos., position.

Note

For 588 machine place slide dial on I throughout.

DRESS

FRONT

** T5. With A COBH. 167 (175, 183) sts. placing odd st. on right hand edge. * K. 10 rows. T8. K. 1 row for foldline. T5. K. 10 rows. MDE. * T6. K. 1 row. COR. 000. Dec. 1 st. each end of every foll. 7th row 16 times to 135 (143, 151) sts. K. to row 116 (122, 128) ** 000. Dec. 1 st. each end of every foll. 6th row to row 57 fin. COL. Set machine for jacquard. K. 1 row. COR. Cont., rep. foll. patt., working steps 1 to 34, then knitting 2 rows A, D, A, B, C, D, E, D, C, B, A, D, A, (60 rows of patt.), at same time still dec. 1 st. each end of every 6th row as before to 96 rows. 103 (111, 119) sts. 000. Cont. straight for 30 rows. 000. Inc. 1 st. each end of the next and then every foll. 3rd (4th, 5th) rows 11 times more to 127 (135, 143) sts. Cont. straight to row 46 (52, 58).

Shape Armholes

Cast off 4 (5, 6) sts. at beg. of the next 2 rows fin. COR. 119 (125, 131) sts. 000. Dec. 1 st. each end of every foll. 3rd row 10 times to 99 (105, 111) sts. Cont. straight to row 58 (64, 70).

Front Neck

Thread up and take off machine the centre 21 (23, 25) sts. Cont. on right sts. only dec. 1 st. every other row on neck 10 times to 29 (31, 33) sts. fin. COR. on row 78 (84, 90).

Shape Shoulder

Cast off 5 (6, 7) sts. at beg. of the next row and at this same edge every alt. row 3 times more. Cast off rem. 9 (7, 5) sts. Work left sts. the same reversing shapings.

BACK

(Work in same sequence of patt. throughout.) Rep. from ** to ** as on front. 135 (143, 151) sts. 000. Dec. 1 st. each end of every foll. 6th row 5 times to 32 rows. 125 (133, 141) sts.

Back Opening

Thread up and take off machine the left 62 (66, 70) sts. K. 1 row on right 63 (67, 71) sts. fin. COL. Cast on 8 sts. for opening facing. 71 (75, 79) sts. Cont., still dec. 1 st. every 6th row as before on side edge to row 57 fin. COL. Set machine for jacquard. K. 1 row. COR. Cont. in patt. to match front at same time still dec. 1 st. every 6th row on right edge as before to 96 rows. 60 (64, 68) sts. 000. Cont. straight for 30 rows. 000. Inc. 1 st. each end of the next and then every foll. 3rd (4th, 5th) rows 11 times more on side edge to 72 (76, 80) sts. Cont. straight to row 46 (52, 58).

Shape Armhole

Cast off 4 (5, 6) sts. on right edge, K. 2 rows fin. COR. 68 (71, 74) sts. 000. Dec. 1 st. every foll. 3rd row on armhole 10 times to 58 (61, 64) sts. Cont. straight to row 78 (84, 90) fin. COR.

Shape Shoulder and Back Neck

Cast off 5 (6, 7) sts. on right edge, K. 2 rows fin. COR. 53 (55, 57) sts. Cast off 5 (6, 7) sts. on right edge, K. 1 row fin. COL. 48 (49, 50) sts. Cast off 25 (26, 27) sts. on left edge, K. 1 row fin. COR. (23 sts.) Dec. 1 st.

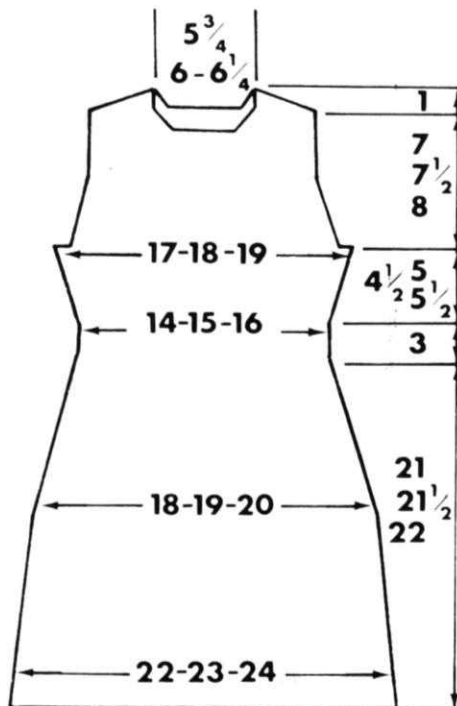

on next and then every foll. row on neck 3 times more, at same time casting off 5 (6, 7) sts. on right edge and at this same edge on the foll. alt. row fin. COR. Cast off rem. 9 (7, 5) sts. Place left 62 (66, 70) sts. back onto same N. as before and cast on 9 sts. to right edge for facing. 71 (75, 79) sts. K. 1 row. COL. K. 1 row. COR. Set counter to 32. Cont. on these sts. to match others reversing shapings.

SLEEVES

T5. With A COBH. 51 (55, 59) sts. placing odd st. on the right hand edge. Rep. from * to * as on front. Set machine for jacquard. T6. K. 1 row. COR. Cont., rep. 60 row patt., at same time inc. 1 st. each end of every foll. 9th row to 81 (85, 89) sts. Cont. straight to 174 (180, 186) sts. fin. COR.

Shape Top

Cast off 4 (5, 6) sts. at beg. of the next 2 rows fin. COR. 73 (75, 77) sts. 000. Dec. 1 st. each end of every foll. 4th row to 49 sts. Dec. 1 st. each end of every row to 21 sts., cast off.

NECKBAND

T5. With A COBH. 95 (99, 103) sts. K. 16 rows. T8. K. 1 row for foldline. T5. K. 16 rows. MDE. K. 1 row. COR. Press back and front, join shoulder seams. With right side of dress facing machine and working from right edge of N., place the right back neck to first 21 (22, 23) N., omitting the 8 back opening facing sts. side neck to next 16 N., front neck to next 21 (23, 25) N., place rest of neck to rem. N. to correspond. Cast off band and neck together to end.

WAISTCOAT

Note

Inc. on the side seam edges on back and fronts by using the 3 st. transfer tool. It is essential that a loop edge is formed throughout on the front, neck and armhole edges for crochet edging.

BACK

T6. With A COBH. 106 (114, 122) sts. 000. K. 20 rows. 000. Inc. 1 st. each end of every foll. 3rd (3rd, 4th) rows 11 times to 128 (136, 144) sts. Cont. straight to 36 (42, 48) rows fin. COR.

Shape Armholes

Cast off 6 (7, 8) sts. at beg. of the next 2 rows fin. COR. 116 (122, 128) sts. 000. Cont., shaping armholes at the same time forming the loop edges as folls. Trans. the 1st and 2nd sts. to the 3rd N. on right edge., push 1 empty N. to B pos. on the same edge. K. 1 row. 115 (121, 127) sts. COL. Trans. the 1st and 2nd sts. to the 3rd N. on left edge, push 1 empty N. to B pos. on same edge. K. 1 row. 114 (120, 126) sts. COR. Cont., rep. the last 2 rows to 90 (96, 102) sts. fin. COR.

Shape Neck

Thread up and take off machine the left 45 (48, 51) sts. 000. Keep the armhole edge straight and form loop edge throughout by the foll. method. Trans. the 1st st. to the 2nd N., then push to B pos. 1 empty N. on the same edge., K. 1 row. 45 (48, 51) sts. COL. On neck edge trans. the 1st and 2nd sts. to the 3rd N., then push to B pos. 1 empty N. on the same edge, K. 1 row. 44 (47, 50) sts. COR. Rep. these last 2 rows, shaping the

six design set





DESIGN 1



DESIGN 2



DESIGN 3



DESIGN 4



DESIGN 5



DESIGN 6

			↑	↘	0	0	0	0	0	0	0	2	2								-		↑							
	7	3	↓	↘	0	0	0	0	0	0	0	1	1	■	■	■	■	■	■	7	1	■	1	+	1	↑				
BOTH TUCK BUTTONS IN	TENSION	H.C.L.	K.C.	S.L.	1	2	3	4	5	6	7	8	9	10	11	12	STEPS		STEPS		TENSION		H.C.L.	TUCK LEFT	TUCK RIGHT	H.C.L.	RIGHT	REVERSE LEVER	SLIDE DIAL	CARRIAGE
5	4	3	2	1	K.H. 800 MACHINE												K.H. 588 MACHINE		1	2	3	4	5	6	7	8				

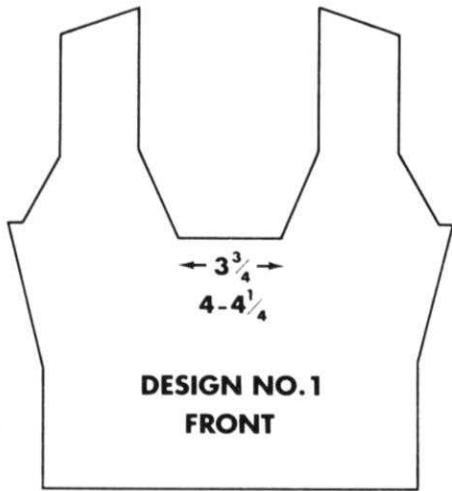

**DESIGN NO. 1
FRONT**

1

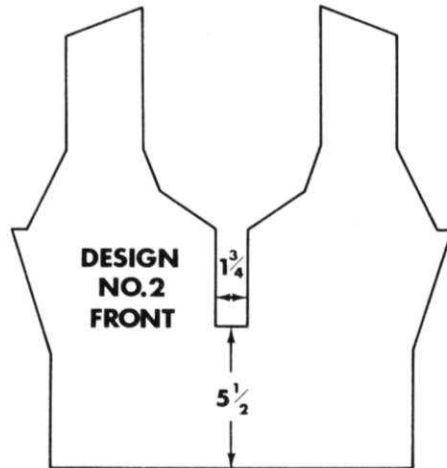

**DESIGN NO. 2
FRONT**

2

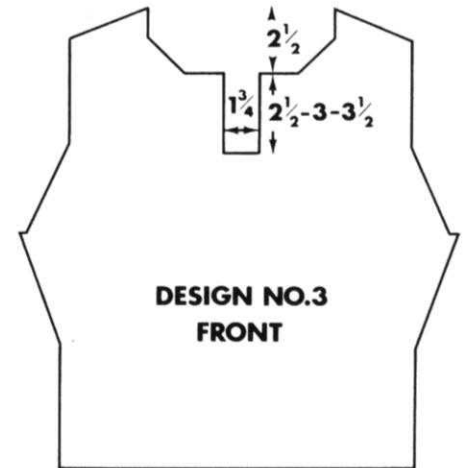

**DESIGN NO. 3
FRONT**

3

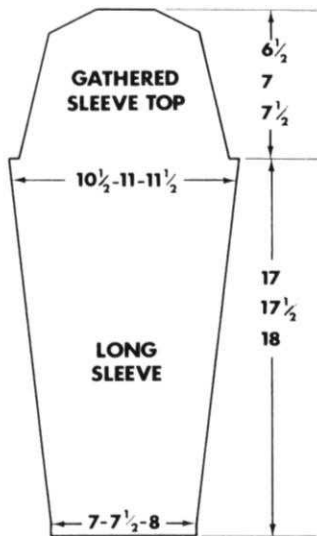

**GATHERED
SLEEVE TOP**

**LONG
SLEEVE**

4

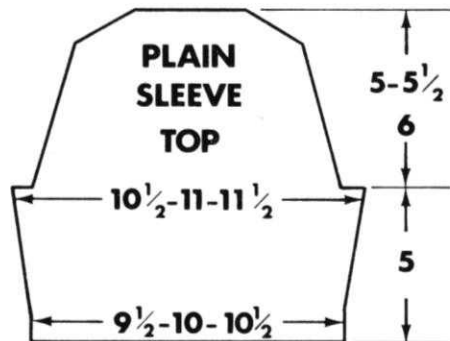

**PLAIN
SLEEVE
TOP**

5

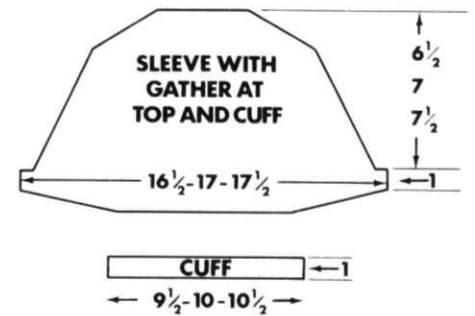

**SLEEVE WITH
GATHER AT
TOP AND CUFF**

CUFF

6

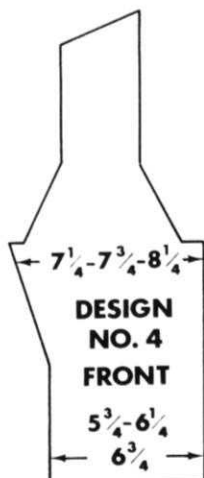

**DESIGN
NO. 4
FRONT**



**DESIGN
NO. 5
FRONT**

(Same
across
measure-
ments
as no.4)

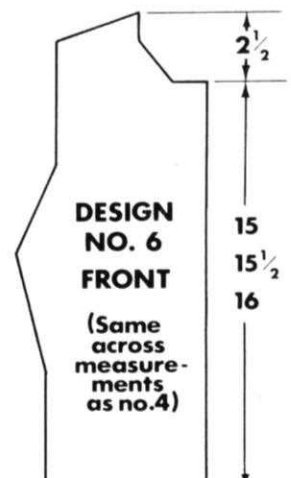

**DESIGN
NO. 6
FRONT**

(Same
across
measure-
ments
as no.4)

SIX DESIGN SET INCLUDING THREE JUMPERS AND THREE CARDIGANS WITH FIVE SLEEVE STYLES.

For KH-585-588 and 800 machines

Materials

Robin Tricel Nylon Perle. The amounts for each design are stated throughout the instructions (see Note). Shoulder pads may be necessary for the sleeves with gathered tops.

Measurements

To fit 32 (34, 36) ins. bust.

Jumper 32 (34, 36) ins. at underarm.

Cardigan 33 (35, 37) ins. at underarm.

17½ (18, 18½) ins. length.

17 (17½, 18) ins. long sleeve seam.

5 (5, 5) ins. short sleeve seam.

2 (2, 2) ins. gathered sleeve seam

Tension

7½ sts. and 11½ rows to 1 in. over st.st. on T7.

Abbreviations

St(s), stitch(es); T., tension; K., knit; COR(L), carriage on right or left; 000., set row counter to 000; cont., continue; patt., pattern; MDE., make double edge by placing each loop at cast on edge onto N in B pos.; rep., repeat; N., needle(s); pos., position; COBH., cast on by hand over every N.; inc., increase; dec., decrease; foll(s), following (follows); beg., beginning; fin., finishing; rem., remaining; alt., alternate; tog., together.

Note

The amounts for each design are stated for the backs, fronts, frills and edgings inclusively, the amounts for each sleeve are stated separately so that any sleeve style can be incorporated into any of the six designs.

FRILLS

* Cast on the stated number of sts., using 2 strands of yarn together, by the finished edge cast on hand method from left to right, cut off 1 strand, thread the 2nd strand through the sinker plate, hang cast-on comb onto loops. T7. K. 1 row. COL. 000. Cont. in patt. from chart for 16 rows. K. 1 plain row. With scrap yarn K. a few rows and take work off machine. *

Narrow Edgings

** Cast on stated number of sts. T6. K. 12 rows. T8. K. 1 row. T6. K. 12 rows. MDE. K. 1 row. COR. **

Wide Edgings

*** Cast on stated number of sts. T6. K. 24 rows. T8. K. 1 row. T6. K. 24 rows. MDE. K. 2 rows. COL. ***

Frill Gathering

With plain side of frill facing machine place 2 sts. onto first N., 1 st. onto next N., rep. this to end of B pos. N. T6. K. 1 row knitting frill and edging tog.

BACK (same for each design)

* T5. COBH. 96 (104, 112) sts. K. 14 rows. T7. K. 1 row for foldline. T5. K. 14 rows. COL. MDE. T7. K. 1 row. COR. 000. * K. 40 rows. 000. ** Inc. 1 st. each end of the next and then every foll. 5th row 11 times to 120 (128, 136) sts. K. to 60 rows fin. COR.

Shape Armholes

Cast off 3 (4, 5) sts. at beg. of the next 2 rows fin. COR. 114 (120, 126) sts. 000. *** Dec. 1 st. each end of every foll. 3rd row 10 times to 94 (100, 106) sts. 000 **** K. 56 (62, 68) rows fin. COR.

Shape Shoulders and Neck

Cast off 5 sts. at beg. of the next 2 rows fin. COR. Thread up and take off machine the centre 36 (38, 40) sts. Work right sts. only as folls. Cast off 5 sts. on right edge, K. 1 row. COL. Cast off 2 sts. on left edge, K. 1 row. COR. Rep. these last 2 rows twice more fin. COR. Cast off rem. 3 (5, 7) sts. Work left sts. to match reversing shapings.

DESIGN No. 1

Materials

7 (7, 8) balls.

JUMPER FRONT

Rep. from * to ** as on back.

Front Neck

Thread up and take off machine the centre 28 (30, 32) sts. Work right sts. only as folls. **** Dec. 1 st. each end of every foll. 3rd row 10 times fin. COR. 23 (25, 27) sts. 000. K. 56 (62, 68) rows. COR. ****

Shape Shoulder

** Cast off 5 sts. at beg. of the next row and at this same edge every alt. row 3 times more fin. COR. Cast off rem. 3 (5, 7) sts. Work left sts. to match reversing shapings.

DESIGN No. 2

Materials

7 (7, 8) balls.

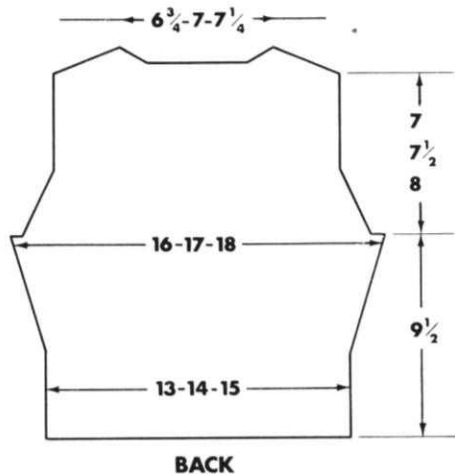

BACK IS THE SAME FOR ALL GARMENTS

JUMPER FRONT

Rep. from * to ** as on back. Inc. 1 st. each end of the next and then each end of every foll. 5th row to 12 rows fin. COR.

Front Opening

Cast off centre 12 sts. Work on right sts. still inc. as before 9 times more to 54 (58, 62) sts. K. to 60 rows fin. COR.

Shape Armhole

Cast off 3 (4, 5) sts. on right edge, K. 2 rows. COR. *** 000. Dec. 1 st. every 3rd row on armhole 10 times, at same time casting off 2 sts. every alt. row on neck edge 7 times, then dec. 1 st. every foll. 4th row on neck to 23 (25, 27) sts. K. to 86 (92, 98) rows fin. COR. Rep. from ** to ** as on design No. 1 front. ***

DESIGN No. 3

Materials

7 (7, 8) balls.

JUMPER FRONT

Rep. from * to **** as on back.

Front Opening

Cast off the centre 12 sts. Work on right sts. as folls. *** K. to 39 (45, 51) rows fin. COL.

Shape Neck

Cast off 4 (5, 6) sts. on left edge, K. 1 row. COR. 37 (39, 41) sts. Cast off 2 sts. every alt. row on neck edge 7 times. 23 (25, 27) sts. K. to 56 (62, 68) rows fin. COR. Rep. from ** to ** as on design No. 1 front. ***

DESIGN No. 4

Materials

9 (9, 10) balls. 5 buttons.

CARDIGAN RIGHT FRONT

* T5. COBH. 42 (46, 50) sts. K. 14 rows. T7. K. 1 row. T5. K. 14 rows. COL. MDE. T7. K. 1 row. COR. 000. K. 40 rows. 000. On right edge inc. 1 st. on next and then every foll. 5th row 11 times more to 54 (58, 62) sts. K. to 60 rows fin. COR.

Shape Armhole and Neck

Cast off 3 (4, 5) sts. on right edge, K. 1 row. COL. For neck cast off 8 (9, 10) sts., on left edge, K. 1 row. COR. 000. 43 (45, 47) sts. Rep. from **** to **** then from ** to ** as on design No. 1 jumper front. Work left front to match, reversing shapings.

DESIGN No. 5

Materials

9 (9, 10) balls. 5 buttons.

CARDIGAN RIGHT FRONT

Rep. from * to * as on design No. 4 cardigan right front.

Shape Armhole and Neck

Rep. from *** to *** as on design No. 2 jumper front. Work left front to match, reversing shapings.

DESIGN No. 6

Materials

8 (8, 9) balls. 7 buttons.

CARDIGAN RIGHT FRONT

Rep. from * to * as on design No. 4 cardigan right front. K. 1 row. COR. 000.

Shape Armhole

Dec. 1 st. every foll. 3rd row on armhole 10 times to 41 (44, 47) sts. fin. COR. 000. Rep. from *** to *** as on design No. 3 jumper front. Work left front to match reversing shapings.

DESIGN No. 1 and 4 LONG SLEEVES (with gathered or plain sleeve top)

Materials

6 (6, 7) balls.

T5. COBH. 54 (58, 62) sts. Work hem as on back to *. Inc. 1 st. each end of every foll. 14 row 12 times to 78 (82, 86) sts. Cont. straight to 188 (194, 100) rows, fin. COR. (Adjust length at this stage if desired.)

Shape Top

Cast off 3 (4, 5) sts. at beg. of the next 2 rows fin. COR. 72 (74, 76) sts. (For sleeve with plain top from * to * on sleeve for designs No. 2 and 5, for gathered top cont. as folls.) * 000. Dec. 1 st. each end of every foll. 5th row to 50 sts. K. to 56 (62, 68) rows. Cast off 3 sts. at beg. of the next 10 rows. Cast off rem. 20 sts.

DESIGN No. 2 and 5 SHORT SLEEVES (with gathered or plain top)

Materials

3 (3, 4) balls.

T5. COBH. 70 (74, 78) sts. Work hem as on back to *. Inc. 1 st. each end of every foll. 9th row 4 times to 78 (82, 86) sts. Cont. straight to 44 (46, 48) rows, fin. COR. (Adjust length at this stage if desired.)

Shaped Top

Cast off 3 (4, 5) sts. at beg. of the next 2 rows fin. COR. 72 (74, 76) sts. (For sleeve with gathered top rep. from * to * on sleeve for designs No. 1 and 4, for plain top cont. as folls.) * 000. Dec. 1 st. each end of every foll. 4th row to 50 sts. K. to 46 (52, 68) rows fin. COR. Cast off 3 sts. at beg. of the next 10 rows. Cast off rem. 20 sts. *

DESIGN No. 3 and 6 SHORT SLEEVE (gathered at cuff and top with frill above cuff)

Materials

4 (4, 5) balls.

With scrap yarn cast on 124 (128, 132) sts. and K. a few rows fin. COR. T7. Change to main yarn. K. 2 rows. For 585 and 588 machines place holding cam lever on II, for 800 machine place holding cam lever on I. Shape curved hem as folls., at the same time placing yarn between the 2 inside edge E pos. N. Push left 35 N. to E pos., K. 1 row. Push right 35 N. to E pos., K. 1 row. COR. Push 7 inside N. on left to D pos., K. 1 row. Push 7 inside N. on right to D pos., K. 1 row. Cont. in this way until all N. are back to B pos., fin. COR. 000. K. 10 rows.

Shape Top

Cast off 3 (4, 5) sts. at beg. of the next 2 rows fin. COR. 118 (120, 122) sts. 000. Dec. 1 st. each end of every foll. 4th row 7 (8, 11) times to 104 (104, 100) sts. Dec. 1 st. each end of every alt. row 15 (15, 13) times to 74 sts. Cast off 4 sts. at beg. of the next 10 rows, cast off rem. 34 sts. Press sleeves. For frills cast on 105 (111, 117) sts. Rep. from * to * as on frills. Stretch and press frills to 26 (27½, 29) ins. For cuff cast on 70 (74, 78) sts. Rep. from ** to ** as on narrow edgings. With wrong side of curved hem facing machine place 9 sts. each end onto B pos. N., place 2 sts. onto each rem. N. Cast off all sts. tog.

DESIGN No. 1 NECKLINE EDGINGS

Back Frill

Cast on 72 (75, 78) sts. Rep. from * to * as on frills. Stretch and press frill to 18 (19, 20) ins.

Back Edging

Cast on 48 (50, 52) sts. Rep. from * to * add

on narrow edging. Place on frill. With right side back facing machine place the centre 36 (38, 40) sts. centrally onto N., the side neck onto rem. 6 N. either side. Cast off all sts. tog.

Front Frill

Cast on 168 (183, 198) sts. and K. as before. Stretch and press frill to 42 (45½, 49) ins.

Front Edging

Cast on 112 (122, 132) sts. and K. as before. Place on frill. With right side of front facing machine and working from right edge of N., place straight edge of neck to first 26 (30, 34) N., shaped neck edge to next 16 N., front neck sts. to next 28 (30, 32) N., place rem. of neck edge to rest of N., cast off all sts. tog.

DESIGN No. 2 NECKLINE EDGINGS

Work back frill and edging as on design No. 1.

Front Frill

Cast on 105 (111, 117) sts. and K. as before. Stretch and press frill to 26 (27½, 29) ins.

Front Edging

Cast on 70 (74, 78) sts. and K. as before. Place on frill. With right side of front facing machine and working from right edge of N. place straight side neck to first 26 (30, 34) N., shaped neck edge to next 22 N., opening straight edge to next 22 N., cast off all sts. tog. Work opposite front edge the same.

DESIGN No. 3 NECKLINE EDGING

Neck Edge

Cast on 96 (100, 104) sts. Rep. from ** to ** as on narrow edgings. Press back and front. Join shoulder seams. With right side of front facing machine and working from right edge of N. place front cast off edge onto first 4 (5, 6) N., front side neck to next 20 N., side back neck to next 6 N., back neck sts. to next 36 (38, 40) N., cast off tog. to this point, place rem. of neck to rest of N. to correspond and cast off tog. to end.

Opening Edge

Cast on 28 (34, 40) sts. and K. as before. Place one opening edge, including double neckband edge, onto N. and cast off tog. Work opposite edge the same.

DESIGN No. 4 NECKLINE EDGING AND FRONT BANDS

Cast on 148 (160, 172) sts. Rep. from ** to ** as on narrow edgings. Press fronts and back, join shoulder seams. With right side left front facing machine and working from right edge of N., place front cast off edge onto first 8 (9, 10) N., shaped neck edge to next 16 N., straight side edge to next 26 (30, 34) N., side back neck to next 6 N., back neck sts. to next 36 (38, 40) N., place rem. of edge to rest of N. to correspond and cast off all sts. tog. to end.

Front Band Frill

Cast on 106 sts. Rep. from * to * as on frills. Stretch and press frill to 26½ ins.

Right Front Band

Cast on 70 sts. ** T6. K. 12 rows. To make buttonholes leave the 5 edge sts., * cast off the next 4 sts. leave the next 10 sts. rep. from * to last 9 sts., cast off next 4 sts., leave last 5 edge sts. Push empty N. to B pos., K. 1 row. Twist loose yarn around empty N. K.

11 rows. T8. K. 1 row. Rep. from ** once more. MDE. K. 2 rows. Place on frill. With right side of right facing machine place edge, including double hem and neckband edges, onto N. and cast off all sts. tog. Work left band the same omitting buttonholes.

DESIGN No. 5 NECKLINE EDGING AND FRONT BANDS

Back frill

Work same as back frill on design No. 1 neckline edging.

Back Edging

Cast on 48 (50, 52) sts. Rep. from *** to *** as on wide edgings. Place on frill. Place on back neck as given in design No. 1 neckline edgings.

Front Frill

Cast on 164 (170, 176) sts. Rep. from * to * as on frills. Stretch and press frill to 44 (45½, 47) ins.

Right Front Band

Cast on 109 (113, 117) sts. ** T6. K. 12 rows. To make buttonholes leave the first 5 edge sts. on left edge, * cast on the next 4 sts., leave the next 9 sts. Rep. from * 3 times more, cast off the next 4 sts. Push empty N. to B pos. K. 1 row. Twist loose yarn around the empty N. K. 11 rows. T8. K. 1 row. Rep. from ** once more. MDE. K. 2 rows. Place on frill. With right side of right front facing machine and working from left edge place the front edge to first 61 sts., the shaped edge to next 22 N., the straight side neck to next 26 (30, 34) N. Cast off all sts. tog. Work left band the same omitting buttonholes.

DESIGN No. 6 NECK EDGE AND FRONT BANDS

Neck Edge

Work same as neck edge for design No. 3.

Front Frill

Cast on 138 (147, 156) sts. Rep. from * to * as on frills. Stretch and press frill to 34½ (36½, 38½) ins.

Right Front Band

Cast on 92 (98, 104) sts. ** T6. K. 12 rows. To make buttonholes leave the first 5 sts. on right edge, * cast off the next 4 sts., leave the next 9 (10, 11) sts. Rep. from * to last 9 sts., cast off the next 4 sts., leave the last 5 sts. Push empty N. to B pos. K. 1 row. Twist loose yarn around empty N. K. 11 rows. T8. K. 1 row. Rep. from ** once more. MDE. K. 2 rows. Place on frill. With right side of right facing machine, place the front edge evenly onto N., including the double neck edge and hem. Cast off all sts. tog. Work left band the same omitting buttonholes.

TO MAKE UP

Press all pieces. Join shoulder, neck edgings and frills at necks. Gather up sleeve tops where necessary, sew sleeves into armholes. Join side and sleeve seams. Sew up front band ends, oversew around buttonholes, press bands and sew on buttons. Sew beginnings of openings on designs No. 2 and 3. To knit rouleau cast on 3 sts. Right part button in. T3. K. rouleau to required length and cast off. Thread rouleau through bands as shown. Tie into bow. Tie very firm knots into the ends and cut away excess. Press all edgings and seams. Sew in shoulder pads into gathered sleeve tops if desired.

pattern cardigan

Materials

8 (9, 10) ozs. ROBIN Casino Crepe. Dark.
1 (1, 2) ozs. ROBIN Casino Crepe.
Medium. 1 (2, 2) ozs. ROBIN Casino
Crepe. Light. 7 small buttons.

Measurements

To fit 32 (34, 36) ins. bust.
32 (34, 36) ins. at underarm.
21½ (22, 22½) ins. length.
4½ (5, 5½) ins. sleeve seam.

Tension

7 sts. and 10½ rows to 1 in. over stocking
stitch.

Abbreviations

dk., dark; med., medium; lt., light; st(s),
stitch(es); T., tension; K., knit; COL(R),
carriage on left or right; MDE., make
double edge by placing each loop at cast on
edge onto needles in B position; 000., set
row counter to 000; fin., finishing; beg.,
beginning; dec., decrease; inc., increase;
foll., following; rem., remaining; rep.,
repeat; patt., pattern; cont., continue; alt.,
alternate; N., needles; trans., transfer.

Note

ROBIN Casino Crepe is equivalent to 4 ply
crepe.

BACK (Dk., throughout)

Cast on 112 (120, 128) sts. * T5. K. 14
rows. T8. K. 1 row for foldline. T5. K. 14
rows. MDE. T7. K. 1 row. COR. 000. * K.
132 rows.

Shape Armhole

Cast off 3 (4, 5) sts. at beg. of the next 2
rows, fin. COR. 106 (112, 118) sts. 000.
Dec. 1 st. each end of every foll. 3rd row 10
times to 86 (92, 98) sts. 000. K. 46 (52, 58)
rows fin. COR.

Shape Shoulders

Cast off 4 (4, 5) sts. at the beg. of the next 8
rows, then cast off 5 (7, 5) sts. at the beg.
of the next 2 rows. K. a few rows on rem. 44
(46, 48) sts. with scrap yarn, take work off
machine.

RIGHT FRONT

With dk. cast on 54 (58, 62) sts. Rep. from *
to * as on back. K. 50 rows in dk. Cont. in
foll. stripe patt. ** K. 4 rows med., 4 rows
lt., 4 rows med. *** K. 4 rows dk., 4 rows lt.,
4 rows dk. Rep. from ** to *** once more.
** K. 46 rows fin. COR.

Shape Armhole

Cast off 3 (4, 5) sts. at beg. of the next row.,
K. to end fin. COL. 51 (54, 57) sts. K. 1 row
more. 000. Dec. 1 st. every 3rd row on
armhole 7 times to 22 rows. Break off dk.,
join on lt. Cont. dec. on armhole 3 times
more to 41 (44, 47) sts. fin. COR. 000.

Shape Neck

Thread up and take off machine 10 (11, 12)
sts. on left edge. 000. Dec. 1 st. every foll.
3rd row on neck to 21 (23, 25) sts. K. to 46
(52, 58) rows fin. COR.

Shape Shoulder

Cast off 4 (4, 5) sts. at beg. of the next row
and at this same edge every alt. row 3 times
more fin. COR. Cast off rem. 5 (7, 5) sts.

LEFT FRONT

With dk. cast on 54 (58, 62) sts. Rep. from *
to * as on back. Break off dk., join on lt. K.
86 rows lt. Break off lt., join on med. K. 47
rows med., fin. COL.

Shape Armhole



Cast off 3 (4, 5) sts. on left edge., K. 1 row.
COR. 51 (54, 57) sts. 000. Dec. 1 st. every
3rd row on armhole 7 times to 22 rows.
Break off med., join on dk. Cont. dec. on
armhole 3 times more to 41 (44, 47) sts. fin.
COR. 000.

Shape Neck

Break off dk. Thread up and take off
machine 10 (11, 12) sts. on right edge for
neck. Cont. in dk., at same time dec. 1 st.
every foll. 3rd row on neck to 16 rows.
Cont. dec. on neck as before to 21 (23, 25)
sts. at same time knitting to 46 (52, 58) rows
fin. COR. and also rep. the stripe patt. from
** to ** as on right front. Cont. in dk., if
necessary, for 2nd and 3rd sizes. Shape
Shoulder to match right front reversing
shapings.

RIGHT SLEEVE

With dk. cast on 68 (72, 76) sts. Rep. from *
to * as on back. Work stripe patt. from ** to
** as on right front (then cont. in dk. for 2nd
and 3rd sizes only) and knitting to 36 (42,
48) rows for each size fin. COR. at the same
time inc. 1 st. each end of every foll. 6th
(7th, 8th) rows to 78 (82, 86) sts.

Shape Top

Cont. in dk. for all sizes, casting off 3 (4, 5)
sts. at beg. of the next 2 rows. 72 (74, 76)
sts. 000. Dec. 1 st. each end of every foll.

3rd row to 42 sts. K. to 48 (52, 56) rows.
Cast off 2 sts. at beg. of the next 10 rows.
Cast off rem. 22 sts. Work left sleeve the
same working in dk. throughout.

NECKBAND

With dk. cast on 124 (136, 148) sts. Rep.
from * to the MDE. on back. Press fronts
and back, join shoulder seams. With right
side of work facing machine and working
from right edge of N. place the front neck
threaded sts. to the first 10 (11, 12) N., place
the side neck to next 30 (34, 38) N., back
neck to next 44 (46, 48) N., place rem. of
neck edge to rest of N. to correspond. Cast
off band and neck edge together to end. Lay
work flat and press band into curve.

RIGHT FRONT BAND (Same for all sizes)

With dk. cast on 102 sts. T5. K. 9 rows. To
make buttonholes and working from right
edge of N., trans. the 6th st. to the 5th N.,
the 7th st. to the 8th N., * now count 13
single sts., trans. the 14th st. to the 13th N.,
the 15th st. to the 16th N., rep. from * 5
times more leaving 4 single sts. on left edge.
Push empty N. to working position. K. 1
row. COL. Twist the long loops over each of
the empty N. separately. K. 8 rows. T8. K.
1 row for foldline. T5. K. 9 rows. Work
buttonholes as before on the next 2 rows. K.
8 rows. MDE. With right side of right front

mans cotton shirt

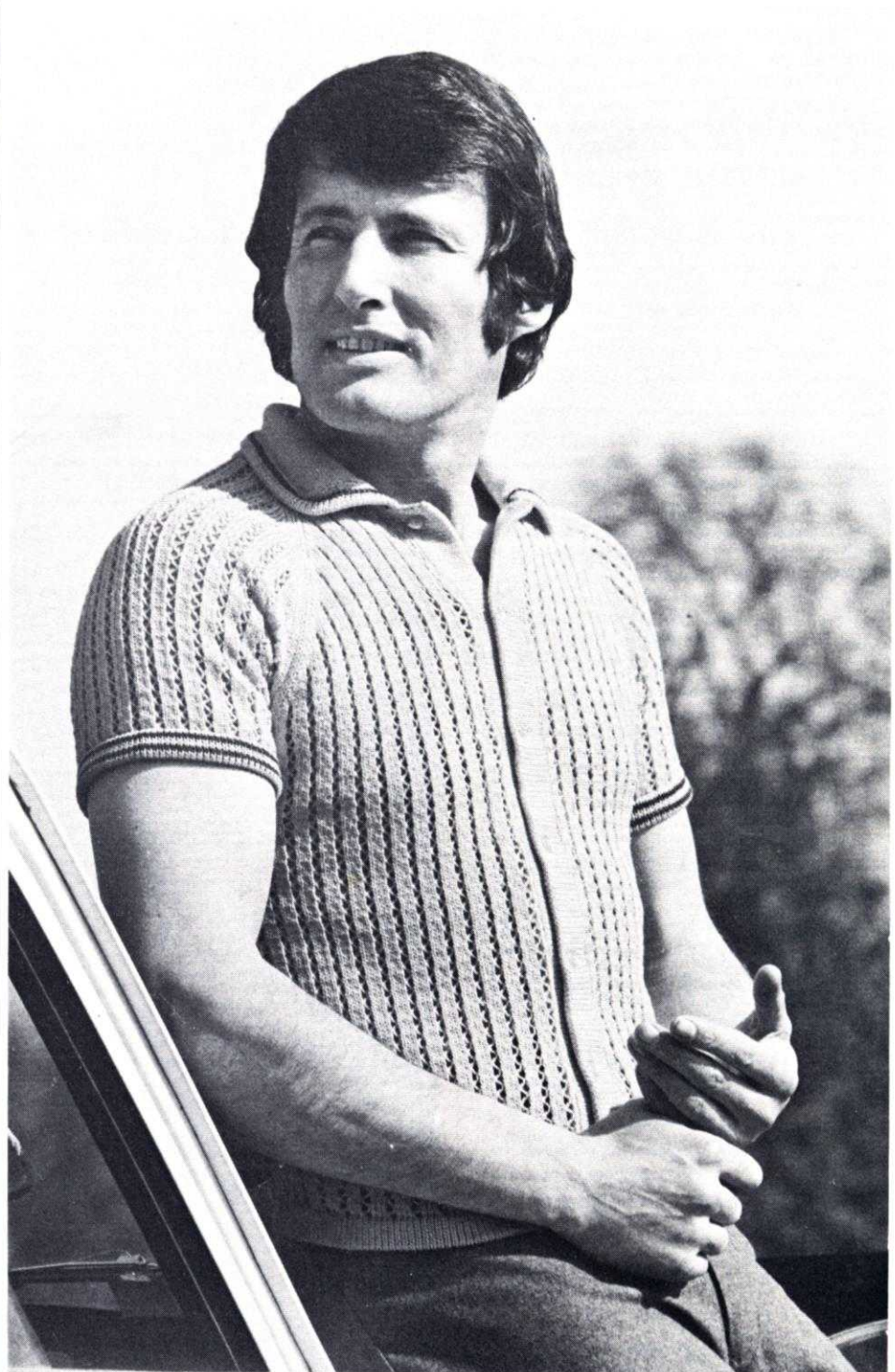
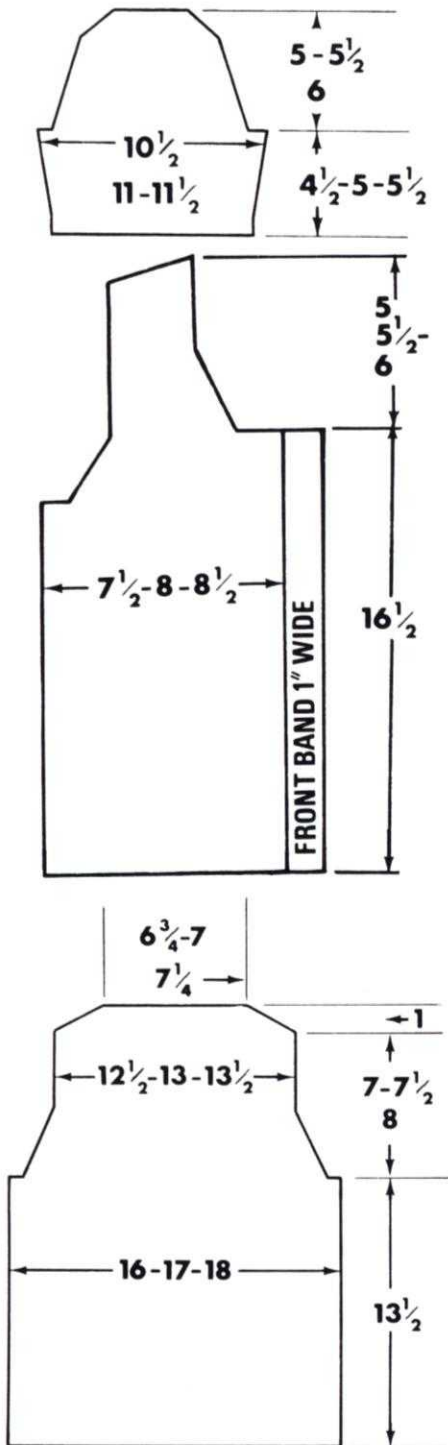

edge facing machine place this edge evenly onto all needles, including double edges of hem and neckband, cast off band and edge together. Work left band to match omitting buttonholes.

TO MAKE UP

Neaten front band ends, oversew buttonholes joining both layers together, press to correct length. Press sleeves and sew into armholes. Join side and sleeve seams. Press all seams. Sew on buttons.

		K.H. 800 MACHINE												STEPS		K.H. 588 MACHINE													
K.C.	L.C.	1	2	3	4	5	6	7	8	9	10	11	12	1	2	3	4	5	6	7	8	REVERSE LEVER	SLIDE DIAL	LACE CARRIAGE	K. CARRIAGE				
3	2													4	4											+	-	→	←
		0				0				0				3	3	■				■								↑	↓
														2	2													→	←
		0				0				0				1	1	■				■								→	←
																												→	←

ladies jumper

Materials

13 (15, 16, 18) 25 grms. balls Wendy Invitation Crochet cotton. 1 ball contrast cotton. 7 buttons.

Measurements

To fit chest sizes 36 (38, 40, 42) ins.
Finished measurements 37 (39, 41, 43) ins.
Length to back neck $22\frac{1}{2}$ (23, $23\frac{1}{2}$, 24) ins.
Sleeve seam 4 ins.

Tension

T7. 14 sts. and 19 rows to 2 ins. over pattern.

Abbreviations

K., knit; sts., stitches; inc., increase; dec., decrease; alt., alternate; foll., following; beg., beginning; rem., remain; H.C.L's., holding cam levers; 000., set row counter at 000; T., tension.

Notes

Dec. at raglan edge is worked by transferring 4th st. onto 5th needle, and moving end sts. 1 needle in. These 5 sts. are kept in st.st. The 2 end sts. at each side of work should be kept in st.st. throughout garment.

BACK

Using waste wool cast on 129 (137, 143, 151) sts. K. a few rows. Change to main wool. T7. K. 19 rows. Make a hem and K. the row. 000. T7. Foll. lace pattern K. 118 rows. *

Shape Raglan

000. Cast off 5 sts. at beg. of next 2 rows. Dec. 1 st. (see notes) at each end of next and foll. alt. row until 35 (37, 39, 41) sts. rem. Cast off.

RIGHT FRONT

Using waste wool cast on 60 (64, 67, 71) sts. having 31 sts. at left of centre and 29 (33, 36, 40) sts. at right. K. as back to * (K. 1 row extra for left front).

Shape Raglan

000. Cast off 5 sts. at beg. of next row. K. 1 row. Dec. 1 st. at beg. of next and foll. alt. row 32 (35, 37, 40) times in all 23 (24, 25, 26) sts. rem. (Carriage is at left.)

Shape Neck

Cast off 4 (5, 6, 7) sts. at beg. of next row. Continue to dec. at raglan edge as before.

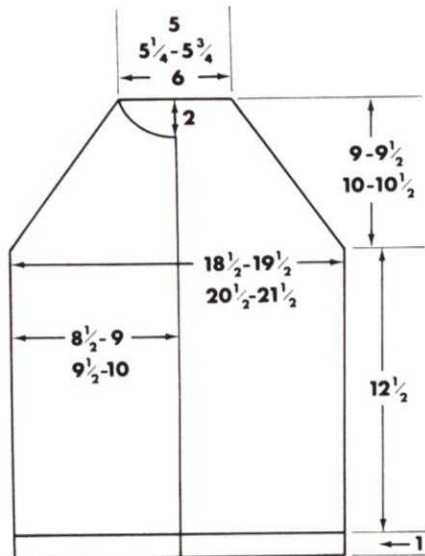

Dec. 1 st. at neck edge on next and foll. alt. row 3 times in all, then every 3rd row 4 times. Continue to dec. at raglan edge only until 2 sts. rem. Cast off.

LEFT FRONT

K. to match right front reversing shapings and making sure that front edge matches that of right front.

SLEEVES

Using waste wool cast on 83 (87, 91, 95) sts. K. a few rows. Change to main yarn. T7. K. 11 rows using contrast K. 2 rows. Using main K. 2 rows. Repeat the last 4 rows once more. Make a hem and K. the row. 000. T7. Foll. lace pattern K. 6 rows inc. 1 st. at each end of next and foll. 4th row 5 times in all 93 (97, 101, 105) sts. K. straight to 28 rows.

Shape Raglan

Cast off 4 sts. at beg. of next 2 rows. K. 1 row. Dec. 1 st. at each end of next and foll. 3rd row 14 (16, 16, 18) times 57 (57, 61, 61) sts. then every alt. row until 15 sts. rem. Cast off.

BUTTONBAND

With main yarn cast on 133 (136, 139, 141) sts. by hand. T7. K. 29 rows. Cast off loosely.

BUTTONHOLE BAND

K. as buttonband making 7 buttonholes evenly spaced on rows 8 and 21 over 2 sts. Cast off.

COLLAR

Cast on 142 (146, 150, 154) sts. by hand. T6. K. 9 rows. K. 2 rows in contrast, then 2 rows in main. T7. Make a hem and K. the row. Cast off 18 sts. at beg. of next 2 rows. K. 6 rows dec. 1 st. (as at raglan edge) at each end of next and every foll. 6th row until 98 (102, 106, 110) sts. rem. Cast off 8 sts. at beg. of next 8 rows. Cast off rem. 34 (38, 42, 46) sts.

TO MAKE UP

Join side, raglan and sleeve seams. Sew on front bands, fold to inside and slip-st. in place. Sew collar extensions to side of collar, and sew collar in place. Neaten buttonholes and sew on buttons. Press seams.

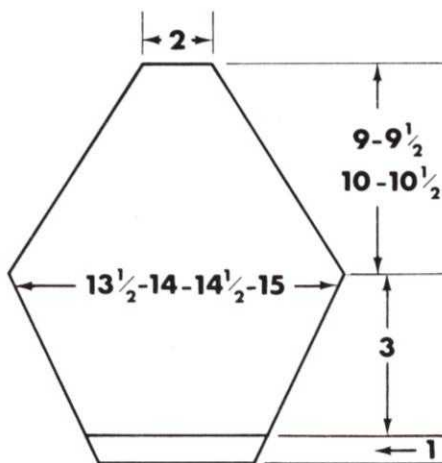

Materials

8 (8, 9, 9) 50 grms. balls Patons Purple Heather 4 ply wool.

Measurements

To fit bust sizes 32 (34, 36, 38) ins.
Length to shoulder 19 ($19\frac{1}{2}$, 20, $20\frac{1}{2}$) ins.
Sleeve seam $19\frac{1}{2}$ ins.

Tension

T7. 14 sts. and 19 rows to 2 ins. after pressing.

Abbreviations

K., knit; sts., stitches; inc., increase; dec., decrease; alt., alternative; foll., following; rem., remain; beg., beginning; H.C.L's., holding cam levers; T., tension; 000., set row counter at 000; M.B., main bed.

BACK

Ribbers Cast on 111 (119, 125, 133) sts. as 2 x 1 rib. T4/4 K. 60 rows. Transfer ribber sts. to M.B.

Single machines Bring forward 111 (119, 125, 133) sts. to B position, return every 3rd needle to A position. Cast on by hand. T5. K. 70 rows. Return empty needles to B position. Pick up loops from adjacent needles.

All machines 000. T7. straight to 60 rows.

Shape Armhole

000. Cast off 4 (4, 5, 5) sts. at beg. of next 2 rows. Dec. 1 st. at each end of next 5 rows, then every alt. row 4 (5, 4, 5) times in all. 85 (91, 97, 103) sts. rem. * K. straight to 66 (72, 76, 82) rows.

Shape Shoulder

Cast off 6 (6, 7, 7) sts. at beg. of next 6 rows and 6 (8, 7, 9) sts. at beg. of next 2 rows. Slip rem. 37 (39, 41, 43) sts. onto a knitting needle.

FRONT

K. as back to * K. straight to 36 (42, 46, 52) rows.

Shape Neck

Cast off 21 (23, 25, 27) sts. at centre. Push needles at left to E position. H.C.L's III. K. the right side first. Dec. 1 st. at neck edge on next 4 rows, then every alt. row 4 times in all. K. straight to 66 (72, 76, 82) rows.

Shape Shoulder

Cast off 6 (6, 7, 7) sts. at beg. of next and foll. alt. row 3 times in all. K. 1 row. Cast off rem. 6 (8, 7, 9) sts. H.C.L's I. K. left side to match reversing shapings.

SLEEVES

Using waste wool cast on 131 (135, 139, 143) sts. K. a few rows. Change to main wool. 000. T7. K. 4 rows. Dec. 1 st. at each end of next and every foll. 5th row 26 times in all. 79 (83, 87, 91) sts. rem. K. straight to 166 rows.

Shape Top

000. Cast off 4 (4, 5, 5) sts. at beg. of next 2 rows. Dec. 1 st. at each end of next 3 rows, then every 3rd row 10 (11, 12, 13) times. Dec. 1 st. at each end of next 5 (6, 5, 6) rows. Cast off 3 sts. at beg. of next 4 rows. Cast off rem. 23 (23, 25, 25) sts.

CUFF

Bring 51 (55, 59, 63) sts. forward to B positions. With wrong side facing replace first row loops in main wool on machine dec. 80 sts. along the row. T7. K. 1 row.

Ribbers Arrange sts. for 2 x 1 rib. T4/4. K. 20 rows. K. 1 loose row and cast off chain



method.

Single machines Transfer every 3rd st. to adjacent needle. Push empty needles to A position. T5. K. 39 rows. Pick first row loops of cuff and place on machine. T10. K. 1 row and cast off chain method.

NECKBAND

With wrong side facing replace on machine 37 (39, 41, 43) sts. from back neck. 30 sts. down front neck, 21 (23, 25, 27) sts. from centre and 30 sts. up front neck 118 (122, 126, 130) sts. T7. K. 1 row.

Ribbers Arrange sts. for 2 x 1 rib. T4/4. K. 18 rows. K. 1 loose row and cast off chain method.

Single machines Transfer every 3rd st. to adjacent needle. Push empty needles to A position. T5. K. 18 rows. Cast off making a chain over empty needles.

TO MAKE UP

Pin out and press with a warm iron over a damp cloth. Join shoulder, side and sleeve seams. Set in sleeves. Turn neckband to wrong side and slip-st. in place. Turn 10 rows of mock rib at lower edge to wrong side and slip-st. in place. Press seams.

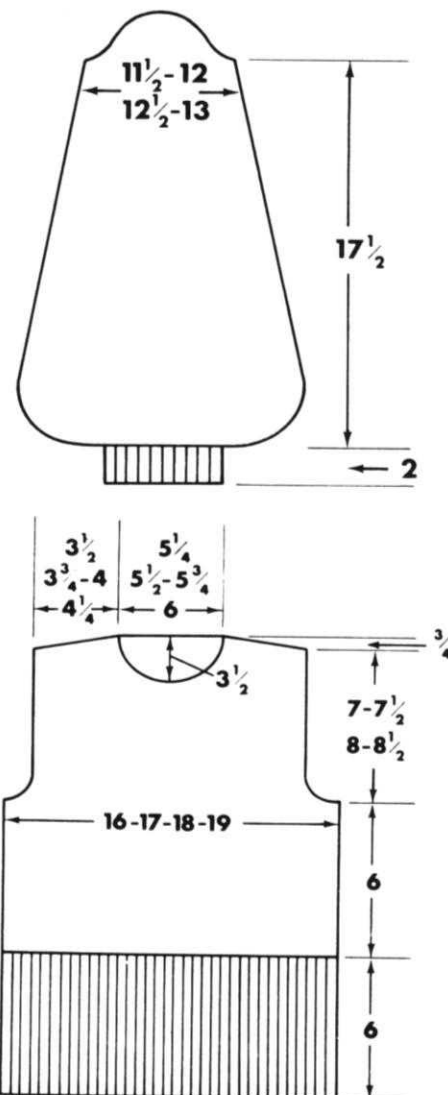

mans cotton sweater



Materials
12 (12, 13, 13) 25 grms. Balls Wendy Invitation Cotton A. 12 (12, 13, 13) 25 grms. Balls Wendy Invitation Cotton B.
Measurements

To fit chest sizes 34 (36, 38, 40) ins.
Length to back neck $26\frac{1}{2}$ (27, $27\frac{1}{2}$, 28) ins.
Sleeve seam $17\frac{1}{2}$ ins.
Tension
T6. $15\frac{1}{2}$ sts. and 20 rows to 2 ins.

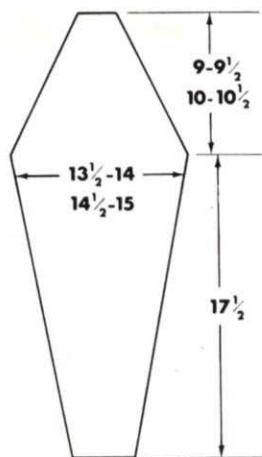
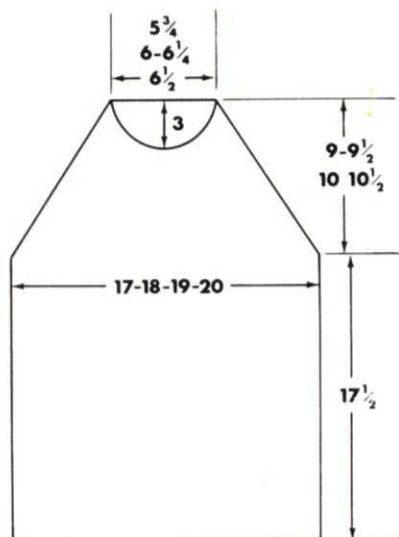

Abbreviations

K., knit; sts., stitches; inc., increase; dec., decrease; beg., beginning; alt., alternate; foll., following; rem., remain; H.C.L's., holding cam levers; 000., set row counter at 000; T., tension.

Notes

When knitting each section of garment work stripes throughout as folls. Cast on in A. K. to row 70; B. to 72; A. to 82; B. to 86; A. to 96; B. to 102; A. to 112; B. to 120; A. to 130; B. to 140; A. to 150; B. to 160; A. to 168; B. to 2; A. to 8; B. to 18; A. to 22; B. to 32; A. to 34; B. until end of work.

Fully fashioning at raglan edges are worked by transferring the 3rd st. onto 4th needle and moving the end sts. 1 needle in. Dec. at neck is worked by moving 2nd st. onto 3rd needle.

BACK

With A. Cast on 134 (142, 150 158) sts. by hand. T5. K. 15 rows. T8. K. 1 row. 000. T6. Foll. stripe pattern (see notes) K. 176 rows.

Shape Raglan

000. Cast off 4 sts. at beg. of next 2 rows. K. 2 rows. Dec. 1 st. each end of next and foll. 4th row 4 (4, 3, 3) times in all * then on every foll. alt. row until 46 (48, 50, 52) sts. rem. K. 1 row. Slip sts. onto a knitting needle.

FRONT

K. as Back to *. K. 1 row. Dec. 1 st. each end of next and foll. alt. rows until 60 (66, 70, 76) rows have been worked.

Shape Neck

Slip centre 24 (24, 26, 26) sts. onto a knitting pin. H.C.L's III. Push 26 (27, 27, 28) sts. at left to E position. K. right side first. Continue to dec. at raglan edge as before, at the same time K. 1 row. Dec. 1 st. at neck edge of next and foll. alt. rows 9 (10, 10, 11) times in all. Keep neck edge straight and dec. on raglan edge only until 2 sts. rem. Cast off. H.C.L. I. K. left side to match reversing all shapings.

SLEEVES

With A cast on 58 (62, 66, 70) sts. by hand. T5. K. 15 rows. T8. K. 1 row. 000. T6. Following stripe pattern K. 26 rows. Inc. 1 st. each end of next and foll. 6th row 23 times 104 (108, 112, 116) sts. K. straight to 176 rows.

Shape Raglan

000. Cast off 4 sts. at beg. of next 2 rows. K. 2 rows. Dec. 1 st. each end of next and foll. 4th row 5 (6, 6, 7) times in all, then on every foll. alt. row until 18 sts. rem. K. 1 row. Slip sts. onto a pin.

NECKBAND

With wrong side of work facing pick up and place on machine 46 (48, 50, 52) sts. from back neck. 18 sts. from first sleeve, 19 sts. down front neck, 24 (24, 26, 26) sts. across front, 19 sts. up front, 18 sts. from second sleeve, 144 (146, 150, 152) sts. T5. K. 6 rows. T4. K. 8 rows. T5. K. 6 rows. Cast off loosely.

TO MAKE UP

Pin out and press with a warm iron over a damp cloth. Join raglan, side and sleeve seams. Turn hems and neckband to inside and slip-st. in place. Press seams.

mother and daughters cardigans



MOTHERS CARDIGAN

Materials

8 (8, 9, 9) 50 grms. balls Patons Purple Heather 4 ply wool. 5 buttons.

Measurements

To fit bust sizes 34 (36, 38, 40) ins.
Finished measurements 36 (38, 40, 42) ins.
Length to back neck 23 (23 $\frac{1}{4}$, 23 $\frac{1}{2}$, 23 $\frac{3}{4}$) ins.
Sleeve seam 17 $\frac{1}{2}$ ins.

Tension

T7. 14 sts. and 19 rows to 2 ins. after pressing.

Abbreviations

K., knit; sts., stitches; inc., increase; dec., decrease; alt., alternate; foll., following; rem., remain; beg., beginning; H.C.L's., holding cam levers; T., tension; 000., set row counter at 000; M.B., main bed.

BACK

Ribbers Cast on 125 (133, 139, 147) sts. as 1 x 1 rib. T4/4. K. 20 rows. Transfer ribber sts. to M.B.

Single machines Using waste wool cast on 63 (67, 70, 74) sts. on alt. needles. K. a few rows, change to main wool. T5. K. 39 rows. Make a hem and K. the row.

All machines 000. T7. K. 114 rows.

Shape Raglan

000. Cast off 2 (4, 4, 6) sts. at beg. of next 2 rows. K. 2 rows. Dec 1 st. at each end of next and foll. alt. row until 39 (41, 43, 45) sts. rem. K. 1 row. Cast off.

RIGHT FRONT

Ribbers Cast on 57 (61, 65, 69) sts. as 1 x 1 rib. T4/4. K. 20 rows. Transfer ribber sts. to M.B.

Single machines Using waste wool cast on 29 (31, 33, 35) sts. on alt. needles. K. a few rows. Change to main wool. T5. K. 39 rows. Make a hem and K. the row.

All machines 000. T7. K. straight to 114 rows. (1 row extra for left front.)

Shape Raglan and Neck

000. Cast off 2 (4, 5, 7) sts at beg. of next row. K. 3 rows. Dec. 1 st. at beg. of next and every foll. alt. row, **at the same time** dec. 1 st. left side (front edge) on next and every foll. 6th row 12 (13, 14, 15) times in all. 9 (7, 6, 4) sts. rem. Keeping front edge straight continue to dec. at raglan edge as before until 2 sts. rem. Cast off.

LEFT FRONT

K. to match right front reversing all shapings.

SLEEVES

Ribbers Cast on 55 (59, 63, 67) sts. as 1 x 1 rib. T4/4. K. 20 rows. Transfer ribber sts. to M.B.

Single machines Using waste wool cast on 28 (30, 32, 34) sts. on alt. needles. K. a few rows. Change to main wool. T5. K. 39 rows. Make a hem and K. the row.

All machines 000. T7. K. 12 rows. Inc. 1 st. at each end of next and foll. 8th row 16 times in all. 87 (91, 95, 99) sts. K. straight to 148 rows. (Adjust length here if required.)

Shape Raglan

000. Cast off 2 (4, 4, 6) sts. at beg. of next 2 rows. K. 1 row. Dec. 1 st. at each end of next and foll. 3rd row 14 (16, 16, 18) times in all, then every alt. row until 13 sts. rem. Cast off.

FRONT BAND

Mark position on left front for 5 buttons the first $\frac{1}{4}$ in. above lower edge and the last one at beg. of neck shaping. Spacing the remainder evenly between.

Ribbers Cast on 15 sts. as 1 x 1 rib. T4/4. K. straight and make buttonholes to match markers, on centre st. until long enough to fit along both fronts and across back neck, stretching slightly, to fit. Cast off.

Single machines Cast on 18 sts. by hand. T6. K. as ribbers making buttonholes over needles 5 and 6 from each end. Cast off.

TO MAKE UP

Pin out and press with a warm iron over a damp cloth. Join side, raglan and sleeve seams. Sew ribbed front band in position. Sew stocking-st. band in position, turn to inside and slip-st. in place. Neaten buttonholes and sew on buttons. Press seams.

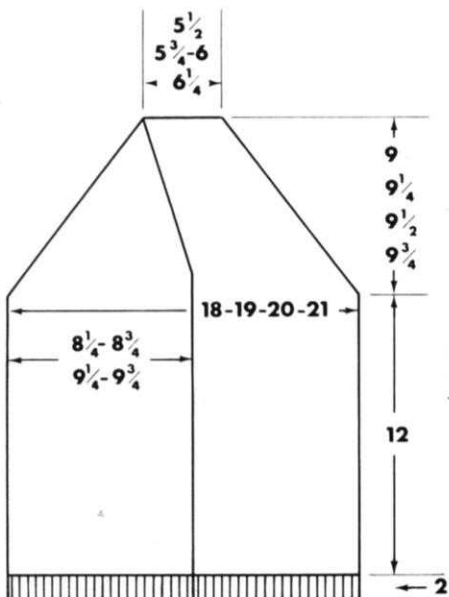
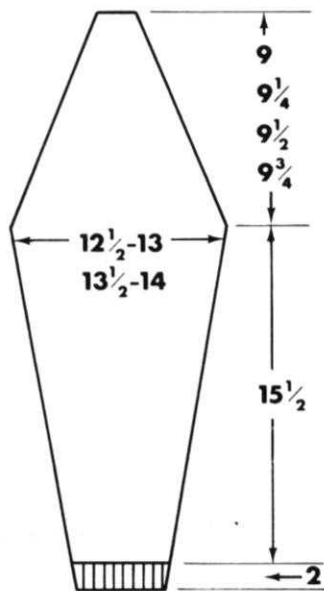

DAUGHTERS CARDIGAN

Materials

6 (7, 7) 50 grms. balls Patons Purple Heather 4 ply wool. 4 buttons.

Measurements

To fit chest sizes 28 (30, 32) ins.
Finished measurements 30 (32, 34) ins.
Length to back neck $19\frac{1}{4}$ (21, $22\frac{1}{2}$) ins.
Sleeve seam 15 (16, 17) ins.

Tension

T7. 14 sts. and 19 rows to 2 ins. after pressing.

Abbreviations

K., knit; sts., stitches; inc., increase; dec., decrease; alt., alternate; foll., following; rem., remain; beg., beginning; H.C.L's., holding cam levers; T., tension; 000., set row counter at 000; M.B., main bed.

BACK

Ribbers Cast on 105 (111, 119) sts. as 1 x 1 rib. T4/4. K. 20 rows. Transfer ribber sts. to M.B.

Single machines Using waste wool cast on 53 (56, 60) sts. on alt. needles. K. a few rows. Change to main wool. T5. K. 39 rows. Make a hem and K. the row.

All machines 000. T7. K. straight to 94 (104, 114) rows.

Shape Raglan

000. Cast off 2 sts. at beg. of next 2 rows. K. 2 rows. Dec. 1 st. at each end of next and foll. alt. row until 33 (35, 37) sts. rem. K. 1 row. Cast off.

RIGHT FRONT

Ribbers Cast on 47 (51, 55) sts. as 1 x 1 rib. T4/4. K. 20 rows. Transfer ribber sts. to M.B.

Single machines Using waste wool cast on 24 (26, 28) sts. on alt. needles. K. a few rows change to main wool. T5. K. 39 rows. Make a hem and K. the row.

All machines 000. T7. K. 94 (104, 114) rows. (K. 1 row extra for left front.)

Shape Raglan and Neck

000. Cast off 2 sts. at beg. of next row. K. 3 rows. Dec. 1 st. at raglan edge on next and foll. alt. rows. **at the same time** dec. 1 st. at neck edge on next and foll. 6th row 9 (11, 12) times in all. Continue to dec. at raglan edge as before until 2 sts. rem. K. 1 row. Cast off.

LEFT FRONT

K. to match right front reversing all shapings.

SLEEVES

Ribbers Cast on 51 (53, 55) sts. as 1 x 1 rib. T4/4. K. 20 rows. Transfer ribber sts. to M.B.

Single machines Using waste wool cast on 26 (27, 28) sts. on alt. needles. K. a few rows. Change to main wool. T5. K. 39 rows. Make a hem and K. the row.

All machines 000. T7. K. 10 rows. Inc. 1 st. at each end of next and foll. 8th row 13 (14, 15) times in all. 77 (81, 85) sts. K. straight to 124 (134, 144) rows.

Shape Raglan

000. Cast off 2 sts. at beg. of next 2 rows. K. 1 row. Dec. 1 st. at each end of next and foll. 3rd row 4 times in all, then every alt. row until 11 sts. rem. K. 1 row. Cast off.

FRONT BAND

Mark position on left front for 4 buttons, the first $\frac{1}{4}$ in. above lower edge and the last one at beg. of neck shaping. Space the remainder evenly between.

Ribbers Cast on 15 sts. as 1 x 1 rib. T4/4. K. straight and make buttonholes to match markers on centre st. until long enough to fit along both fronts and across back neck, stretching slightly to fit. Cast off.

Single machines Cast on 18 sts. by hand. T6. K. as ribbers making buttonholes over needles 5 and 6 from each end.

TO MAKE UP

Pin out and press with a warm iron over a damp cloth. Join side, raglan and sleeve seams. Sew ribbed front band in position. Sew stocking-st. band in position, turn to inside and slip-st. in place. Neaten buttonholes and sew on buttons. Press seams.

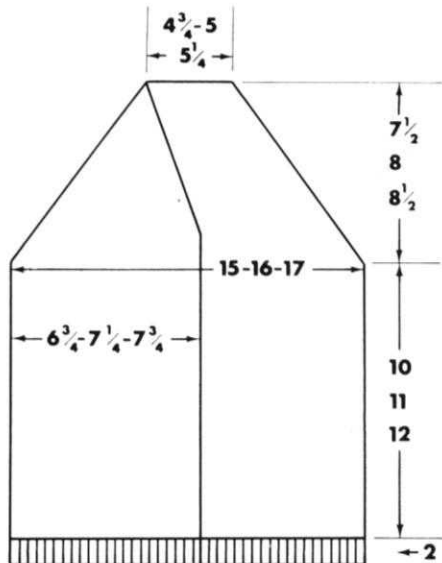
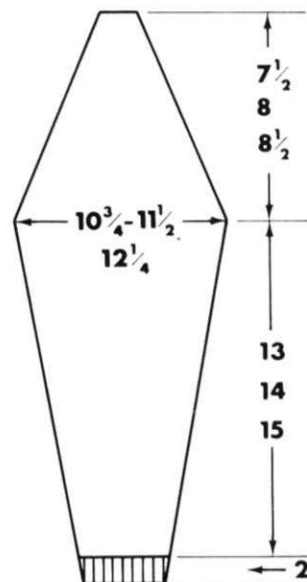

fuller figure cardigan

(NOT FOR PUNCH CARD MACHINES)

Materials

15 (17, 18, 20) ozs. Robin Vogue 4 ply wool. 5 buttons.

Measurements

To fit bust sizes 38 (40, 42, 44) ins.

Finished measurements 39 (41, 43, 45) ins.

Length to shoulder 24 (24½, 25, 25½) ins.

Sleeve seam 17½ ins.

Tension

T6. 15 sts. and 20 rows to 2 ins. after pressing.

Abbreviations

K., knit; sts., stitches; inc., increase; dec., decrease; foll., following; alt., alternate; beg., beginning; rem., remain; T., tension; 000., set row counter at 000; M.B., main bed.

Notes

Needles in A position are counted as 1 st. when shaping. Decreasing at neck edge is worked by transferring 21 st.st. onto 22nd needle. Move all end sts. 1 needle in remembering that the 20th needle is always in A position. Decreasing must be worked before setting the lace pattern, and the S.D. moved 1 place to keep pattern correct.

BACK

Ribbers Cast on 145 (153, 161, 169) sts. as 1 x 1 rib. having extra st. at right T4/4. K. 10 rows. Transfer ribber sts. to M.B.

Single machines Using waste wool cast on 73 (77, 81, 85) on alt. needles having extra st. at right. K. a few rows. Change to main wool. T4. K. 19 rows. Make a hem and K. the row. 145 (153, 161, 169) sts.

All machines 000. T5. S.D. on 3. Foll. lace pattern. K. 42 rows. Transfer centre and every foll. 8th st. each side to adjacent needle. Return empty needles to A position, if end sts. are selected leave these in B position. T6. K. straight to 156 rows.

Shape Armholes

000. Cast off 5 (5, 6, 6) sts. at beg. of next 2 rows. Dec. 1 st. at the beg. of next 7 rows, then every alt. row 5 (6, 6, 7) times 111 (117, 123, 129) sts. K. straight to 80 (84, 90, 94) rows.

Shape Shoulders

Cast off 7 sts. at beg. of next 8 rows and 5 (7, 9, 11) sts. at beg. of next 2 rows. Cast off rem. 45 (47, 49, 51) sts.

RIGHT FRONT

Ribbers Cast on 68 (72, 76, 80) sts. as 1 x 1 rib. T4/4. K. 10 rows. Transfer ribber sts. to M.B.

Single machines Using waste wool cast on 34 (36, 38, 40) sts. on alt. needles. K. a few rows. Change to main wool T4. K. 19 rows. Make a hem and K. the row. Inc. 1 st. at right edge. 68 (72, 76, 80) sts.

All machines 000. T5. S.D. on 6. Foll. lace pattern K. 42 rows. Carriage is at right. Break wool.

POCKET

H.C.L's III. Push 28 sts. at left and 9 (13, 17, 21) sts. at right to E position. K. on rem. 31 sts. T2. Working in st.st. K. 18 rows. Pick up loops of first row in st.st. and place on needles. T6. K. 80 rows. Break wool. Take carriage over to right side of work. Return all needles in E position to B position by hand. H.C.L's I. Counting from



left side (front edge). Transfer the 20th and every foll. 8th st. onto adjacent needles and push empty needles to A position. 000. Keeping 19 sts. at front edge in lace K. 114 rows. (K. 1 row extra for left front.)

Shape Armhole and Neck

000. Cast off 5 (5, 6, 6) sts. at beg. of next row. K. 1 row. Dec. 1 st. (see notes) at neck edge on next foll. 4th rows **at the same time** dec. 1 st. at armhole edge on next 7 rows then every alt. row 5 (6, 6, 7) times. Continue to dec. at neck edge only as before until 35 (38, 41, 44) sts. rem. then every 6th row until 33 (35, 37, 39) sts. rem. K. straight to 80 (84, 90, 94) rows.

Shape Shoulder

Cast off 7 sts. at beg. of next and foll. alt. row 4 times in all. K. 1 row. Cast off rem. 5 (7, 9, 11) sts.

LEFT FRONT

S.D. on 7. K. to match right front reversing all shapings.

SLEEVES

Ribbers Cast on 67 (71, 75, 79) sts. as 1 x 1 rib. T4/4. K. 20 rows. Transfer ribber sts. to M.B.

Single machines Using waste wool cast on 34 (36, 38, 40) sts. on alt. needles. K. a few rows. T4. Change to main wool K. 39 rows. Make a hem and K. the row.

All machines Transfer centre and every foll. 8th st. each side to adjacent needle. Push empty needles to A position. 000. T6. K. 10 rows. Inc. 1 st. at each end of next and foll.

8th row 17 times in all 101 (105, 109, 113) sts. K. straight to 156 rows.

Shape Top

000. Cast off 5 (5, 6, 6) sts. at beg. of next 2 rows. Dec. 1 st. at each end of next 5 rows, then every 3rd row 6 (6, 10, 10) times, then every alt. row 8 (10, 6, 8) times. Dec. 1 st. at each end of next 5 (5, 3, 3) rows. Cast off 3 sts. at beg. of next 6 (6, 8, 8) rows. Cast off rem. 25 sts. making a chain over empty needles.

FRONT BAND

Mark position on left front for 5 buttons, the first $\frac{1}{4}$ in. above lower edge and the last on at beg. of neck shapings. Space the remainder evenly between.

Ribbers Cast on 15 sts. as 1 x 1 rib. T3/3. K. straight and make buttonholes to match markers on centre st. until long enough to fit along both fronts and across back neck stretching slightly to fit. Cast off.

Single machines Cast on 18 sts. by hand. T6. K. as ribbers making buttonholes over needles 5 and 6 from each end cast off.

TO MAKE UP

Pin out and press with a warm iron over a damp cloth. Join side, raglan and sleeve seams. Sew ribbed front band in position. Sew stocking st. band in position, turn to inside and slip-st. in place. Sew side seams of pocket linings together. Slip-st. narrow edges of pocket tops in place. Neaten buttonholes and sew on buttons. Press seams.

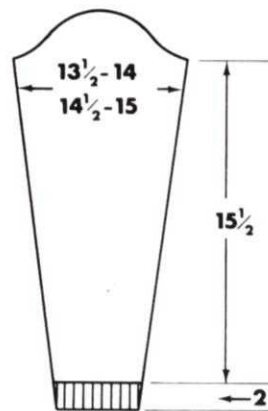
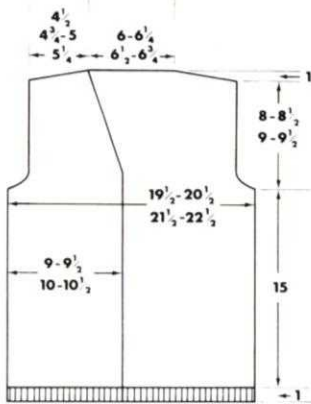

STEPS	CARRIAGE - DIRECTION	COLOUR	TENSION DIAL	H.C.L. LEFT	H.C.L. RIGHT	588 ONLY CHANGE KNOB	NEEDLE SELECTION	WEAVING APPARATUS	WEAVING THREAD COLOUR	LACE CARRIAGE DIRECTION	588 ONLY CHANGE LEVER	588 ONLY LAYING IN COLOUR
7	↪						1 2 3 4 5 6 7 8					
6	↪											
5	↪						1 3 5					
4	↪						2 4					
3	↪						1 3 5					
2	↪						2 4					
1	↪	I	I	I	I	N	1 3 5					

Materials

12 (13, 14, 15, 16) ozs. Listers Crisp Crepe 4 ply wool in M. 5 (5, 5, 6, 6) ozs. in contrast A. 5 (5, 5, 6, 6) ozs. in contrast B.

Measurements

To fit chest sizes 34 (36, 38, 40, 42) ins. Actual measurements 36 (38, 40, 42, 44) ins. Length to back neck 25 $\frac{1}{2}$ (25 $\frac{1}{4}$, 26, 26 $\frac{1}{2}$, 26 $\frac{1}{2}$) ins. Sleeve seam 17 $\frac{1}{2}$ (18, 18, 18 $\frac{1}{2}$, 18 $\frac{1}{2}$) ins.

Tension

T7. 14 $\frac{1}{2}$ sts. and 21 rows to 2 ins. over stocking stitch.

T7. 15 sts. and 21 rows to 2 ins. over Fair-Isle.

Abbreviations

K., knit; sts., stitches; inc., increase; dec., decrease; beg., beginning; alt., alternate; foll., following; rem., remain; M.B., main bed; H.C.L's., holding cam levers; T., tension; 000., set row counter at 000.

Notes

On machine K585. 2 rows will register on row counter for every row knitted in 2 colours.

BACK

Ribbers Using M, cast on 135 (143, 151, 157, 165) sts. for 1 x 1 rib, having the extra needle on right hand side. T4/4. K. 26 rows. Transfer ribber sts. to M.B.

Single machines With waste wool cast on 68 (72, 76, 79, 83) sts. having the extra needle on right hand side. K. a few rows. Change to M. T5. K. 51 rows. Make a hem and K. the row 135 (143, 151, 157, 165) sts.

All machines 000. T7. S.D. I. Foll. chart K. 152 rows (see notes for 585).

Shape Armholes

000. Cast off 6 sts. at beg. of next 2 rows. Dec. 1 st. each end of next 11 (12, 13, 13, 14) rows. 101 (107, 113, 119, 125) sts. * K. straight to 82 (84, 86, 90, 92) rows.

Shape Shoulders

Cast off 6 (6, 6, 7, 7) sts. at beg. of next 8 rows, and 4 (6, 8, 6, 8) sts. at beg. of foll. 2 rows. Slip rem. 45 (47, 49, 51, 53) sts. onto a knitting needle.

FRONT

K. as back to * K. straight to 60 (62, 64, 62, 64) rows.

Shape Neck

Slip centre 25 (27, 29, 31, 33) sts. onto a stitch holder. Push 38 (40, 42, 44, 46) needles at left to E position. H.C.L's II. K. right side first. K. 1 row. Dec. 1 st. at neck edge on next and foll. alt. rows 10 times in all. 28 (30, 32, 34, 36) sts. rem. K. straight to 82 (84, 86, 90, 92) rows.

Shape Shoulder

Cast off 6 (6, 6, 7, 7) sts. at beg. of next and foll. alt. rows 4 times in all. K. 1 row. Cast off rem. 4 (6, 8, 6, 8) sts. Return needles in E position to knitting position H.C.L's I. Join wool at centre and K. to match right side reversing all shapings.

SLEEVES

Ribbers Using M, cast on 61 (65, 69, 73, 77) sts. for 1 x 1 rib, having the extra needle at right hand side. T4/4. K. 26 rows. Transfer ribber sts. to M.B.

Single machines With waste wool cast on 31 (33, 35, 37, 39) sts. on alt. needles having the extra needle to right hand side. K. a few

Materials

Long length 16 (17, 19, 20) balls Templetons Ayrwave. Short length 13 (14, 16, 17) balls Templetons Double Knitting yarn.

Measurements

To fit bust sizes 32 (34, 36, 38) ins.

Long length to shoulder 34 (34½, 34½, 34½) ins.

Short length to shoulder 27 (27½, 27½, 27½) ins.

Tension

T9. 12 sts. and 17 rows to 2 ins. Check tension carefully.

Abbreviations

K., knit; sts., stitches; inc., increase; dec., decrease; alt., alternate; beg., beginning; foll., following; rem., remain; T., tension; 000., set row counter at 000.

Notes

This garment is made up on purl side, but can be reversed if required. Use side weights.

LONG JACKET

BACK

Cast on 132 (138, 144, 150) sts. by hand. T9. K. 16 rows. 000. T9. Foll. pattern chart. K. 10 rows. Dec. 1 st. each end of next and foll. 10th row 18 times in all. 96 (102, 108, 114) sts. K. straight to 190 rows.

Shape Armholes

* 000. Cast off 6 sts. at beg. of next 2 rows. Dec. 1 st. each end of next and foll. alt. rows 7 (8, 9, 10) times in all. 70 (74, 78, 82) sts. K. straight to 74 (76, 78, 80) rows.

Shape Shoulders

Cast off 5 sts. at beg. of next 6 rows, and 5 (6, 7, 8) sts. at beg. of foll. 2 rows. Slip rem. 30 (32, 34, 36) sts. onto a knitting pin.

LEFT FRONT

Cast on 61 (64, 67, 70) sts. by hand. T9. K. 7 rows (6 rows on right front). Cast on 10 sts. at beg. of next row 71 (74, 77, 80) sts. K. to 16 rows. 000. T9. Foll. chart but keep 10 sts. at left side (front edge) in stocking stitch. K. 10 rows. Dec. 1 st. at beg. (side edge) of next and foll. 10th row 18 times in all. 53 (56, 59, 62) sts. K. straight to 190 rows (1 extra row on right front).

Shape Armholes

* 000. Cast off 6 sts. at beg. of next row. K. 1 row. Dec. 1 st. at beg. of next and foll. alt. rows 7 (8, 9, 10) times in all. 40 (42, 44, 46) sts. K. straight to 29 rows.

Shape Neck

Cast off 5 sts. at beg. of next row. Carriage at right. Slip 5 sts. at opposite end to carriage onto a pin. K. 1 row. Dec. 1 st. at neck edge on next 6 rows, then on alt. rows until 20 (21, 22, 23) sts. rem. K. straight to 74 (76, 78, 80) rows.

Shape Shoulders

Cast off 5 sts. at beg. of next and foll. alt. rows 3 times. K. 1 row. Cast off rem. 5 (6, 7, 8) sts.

RIGHT FRONT

K. as left front reversing all shapings.

NECKBAND

With plain side facing pick up 5 sts. from pin on left front, 42 (44, 46, 48) sts. up front, 30 (32, 34, 36) sts. across back neck, 42 (44, 46, 48) sts. down right front and 5 sts. from pin. 124 (130, 136, 142) sts. 000. T8. K. 14 rows. Cast off very loosely.

ARMBANDS

Join shoulder seams. With plain side facing pick up and place on machine 106 (110, 114, 118) sts. from round armholes T8. K. 14 rows. Cast off very loosely.

TO MAKE UP

Join side seams. Turn front bands and hem to inside and slip-st. in place. Turn neckband and armbands to outside and sew down neatly.

SHORT JACKET

BACK

Cast on 120 (126, 132, 138) sts. by hand. T9. K. 16 rows. 000. T9. Foll. pattern chart. K. 10 rows. Dec. 1 st. at each end of next and foll. 10th row 12 times in all. 96 (102, 108, 114) sts. K. straight to 130 rows.

Shape Armholes

K. as Long Jacket from * to end.

LEFT FRONT

Cast on 55 (58, 61, 64) sts. by hand. T9. K. 7 rows (6 rows on right front). Cast on 10 sts. at beg. of next row 65 (68, 71, 74) sts. K. to 16 rows. 000. T9. Foll. chart but keep 10 sts. at left side (front edge) in stocking stitch. K. 10 rows. Dec. 1 st. at beg. (side edge) of next and foll. 10th row 12 times in all. 53 (56, 59, 62) sts. K. straight to 130 rows. (1 extra row on right front.)

Shape Armholes

K. as Long Jacket from * to end.

RIGHT FRONT

K. as left front reversing all shapings.

NECKBAND, ARMBANDS and MAKE UP as Long Jacket.

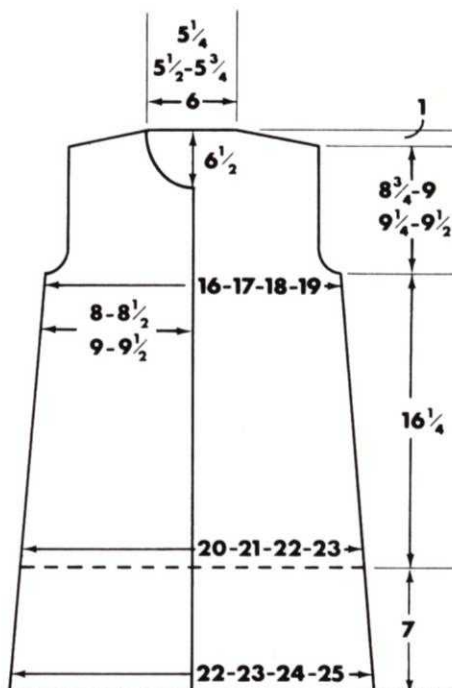

Materials

7 ozs. Patons Quickerknit Baby wool. 4 buttons. 2 yds. narrow ribbon. Elastic for waist. Crochet hook.

Measurements

Coat To fit chest size 18 ins.

Length to back neck 10½ ins.

Sleeve seam 5½ ins.

Leggings Waist to ankle 15½ ins.

Tension

T7. 13 sts. and 24 rows to 2 ins. over pattern.

T7. 13½ sts. and 20 rows to 2 ins. over st.st.

Abbreviations

K., knit; sts., stitches; inc., increase; dec., decrease; beg., beginning; alt., alternate; rem., remain; foll., following; T., tension; 000., set row counter at 000; H.C.L.'s., holding cam levers.

COAT—BACK

With waste wool cast on 65 sts. K. a few rows. Change to main wool. T7. K. 2 rows. S.D. 3. Press buttons 1 and 5 H.C.L.'s III. K. 4 rows. H.C.L.'s I. K. 2 rows. Foll. chart K. 64 rows.

Shape Raglan

000. Cast off 2 sts. at beg. of next 2 rows. Dec. 1 st. each end of next and foll. alt. rows 11 times in all. K. 1 row 39 sts. rem. Slip sts. onto a knitting pin.

LEFT FRONT

With waste wool cast on 33 sts. K. a few rows. Change to main wool. T7. K. edging as back. 000. Foll. chart K. 64 rows. (1 extra row on Right Front).

Shape Raglan

000. Cast off 2 sts. at beg. of next row. K. 1 row. Dec. 1 st. at beg. of next and foll. alt. rows 11 times in all. K. 1 row 20 sts. rem. Slip sts. onto a knitting pin.

RIGHT FRONT

K. as left front reversing all shapings and omitting last row to keep pattern correct.

SLEEVES

With waste wool, cast on 37 sts. K. a few rows. T7. K. edging as back. 000. Foll. chart K. 8 rows. Inc. 1 st. each end of next and foll. 8th row 6 times in all. 49 sts. K. straight to 56 rows.

Shape Raglan

000. Cast off 2 sts. at beg. of next 2 rows. Dec. 1 st. each end of next on foll. alt. row 11 times in all. K. 1 row. 23 sts. rem. Slip sts. onto a knitting pin.

YOKE

Bring forward 100 needles to B position. With plain side of work facing place 20 sts. from left front onto first 14 needles (dec. 6 sts. evenly) 23 sts. from left sleeve, 39 sts. from back onto next 26 needles (dec. 13 sts. evenly) 23 sts. from right sleeve, 20 sts. from right front on last 14 needles (dec. 6 sts. evenly) T7. K. 14 rows. Slip sts. onto a knitting needle. Bring forward 67 needles to B position. Replace sts. on machine (dec. 33 sts. evenly along row) T6. K. 10 rows. Cast off.

TO MAKE UP

Pin out and press with a warm iron over a damp cloth. Unravel waste wool, pick up loops and cast off with a knitting needle. Join sides, sleeve and remainder of raglan seams. Using crochet hook, work 2 rows of

