

# knitking

*magazine*

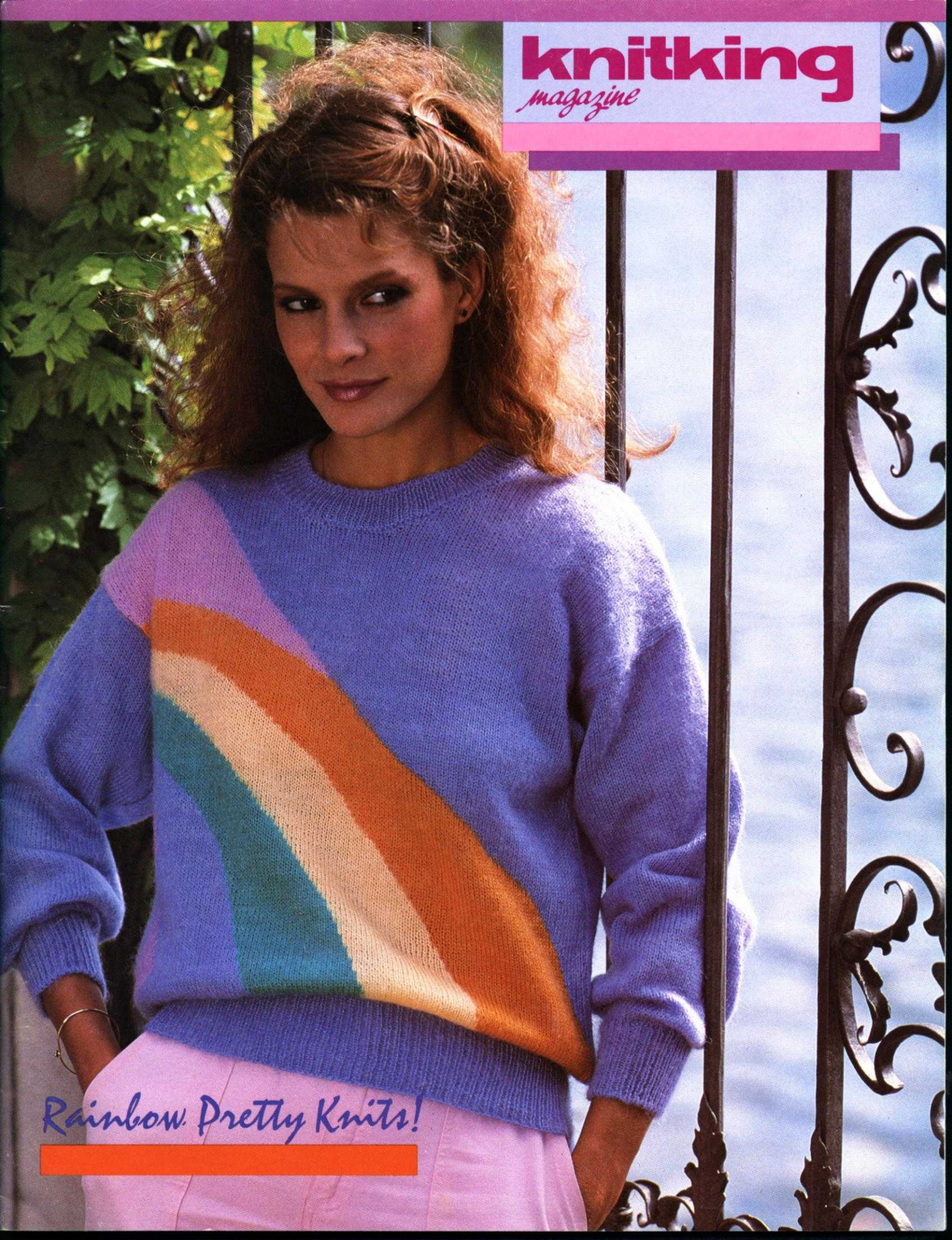

*Rainbow. Pretty Knits!*



359

## Suit Yourself...



in a 3-piece ensemble. The Skirt is knitted sideways with 4 pleats. The Shell has cap sleeves and K1, P1 Ribbing for the waistband.

Mock Ribbing is used for the Jacket.

Knit it in Sizes 6 to 16  
using Venetia yarn.







# Table of Contents

	PAGE NO.
359—Woman's Three-Piece Suit	13
360—Woman's Cape	14
361—Man's Intarsia Pullover	16
362—Woman's Intarsia Pullover	17
363—Woman's Striped Top	18
364—Man's V-Neck Top	19
365—Man's Ski Sweater	20
366—Woman's Dress	21
367—Woman's Two-Piece Suit	22
368—Woman's Three-Piece Suit	24
369—Man's Argyle Pullover	26
370—Woman's Rainbow Top (Cover)	27
371—Woman's Embroidered Top	27
372—Woman's Basketweave Jacket	29
373—Woman's Crochet Collar Top	30
374—Woman's Striped Top	31
375—Woman's Lace Top	31
376—Boy's Pullover	33
377—Woman's Lace Top	34
378—Woman's Striped Top	35
KNITKING NEWS	36

## Cover



Knit a gorgeous Top in cloud soft Show yarn. Our Cover Model, in Rainbow colors, is drawn on the Knitleader and you knit it using the Intarsia technique. Bands are K1, P1 Ribbing. Sizes 6 to 12.

# 370

Publisher: KNITKING CORPORATION, 1128 Crenshaw Blvd., Los Angeles, Calif. 90019. Telephone: (213) 938-2079. Published quarterly. Subscriptions: USA — \$18.00 annually, single copies \$5.00. \$21.00 all other countries. The entire contents of KNITKING MAGAZINE are copyright and must not be reproduced in any shape or form without the express permission, in writing, of the publisher.  
© COPYRIGHT 1984 by KNITKING CORPORATION.

# knitking

magazine

## Editorial

It has taken a long time in the U.S.A. where only in the past three years has interest and enthusiasm for machine knitting really taken off. In the early 1950's we only knew the original KNITKING machines made in W. Germany and the Speed-O-Knit made in Switzerland. During the middle and late fifties, several other brands found their way onto the American market. Brother Industries and Silver Seiko of Japan started the long climb to their eminent position as the top two knitting machine manufacturers in the world today. Several other Japanese manufacturers got into the business with inferior quality machines and poor service. They, almost without exception, subsequently failed. Some European manufacturers began producing heavy and somewhat cumbersome double bed machines that failed to make a lasting impression. One American and one Germany company tried to cash in on the success of Knittax, the company which, for many years, produced KNITKING machines for the U.S. market. They actually copied the design and function patented by Knittax which inevitably got them into trouble and they too disappeared from the market.

In the 'old days' knitting machine manufacturers usually produced one, at the most two different models, their degree of advertising was minimal and our merchandising was tough. We took time on Radio and TV and we advertised in national knitting magazines. We hired and trained salesmen on a regular weekly basis and sent them into people's homes to follow up leads obtained from such advertising, but the percentage of sales per demonstration was poor and the lead cost per sale was very high. There were very few people in the U.S. with any real knowledge of machine knitting and an even lesser number who were able to teach their skills to new machine owners. At KNITKING, we have always been fortunate in regard to the skills of our teachers and machine knitting experts. As pioneers in this business, we are thrilled that our persistence and that of a few other pioneer organizations is, at last, paying off. Consumer interest and sales are increasing steadily.

Machine design today is a far cry from the hand-fed manual pattern selection machines of 30 years ago (and yet many of these old machines are still in use). Nowadays, you really have a choice: Push Button Pattern Selection, Punch Card Pattern Selection, Electronic Computer Pattern Selection, machines for fine needle knitting, standard needle knitting and for bulky knitting plus built-in charting accessories, automatic ribber to knitter transfer carriages, automatic bind off carriages, etc.

We are pleased to note and we appreciate the increasing number of knitters who are using their knowledge and their brains to develop the new skills needed to write text books, pattern books and know-how articles. Some new publications are offered in this issue. We endorse every one of them.

It was almost inevitable in this computer age that computerized programming of pattern designs would become a part of both hand and machine knitting. Already several companies are offering such services. For a fee, they will feed your measurements and other relevant information, such as stitch and row gauge, into a computer and it will produce all the information you need to knit a garment guaranteed to fit you.

The equipment available to perform this service can cost several thousand dollars...obviously more money than the average knitter can and would spend to do her own computing. We are happy to tell you that KNITKING is collaborating with a Japanese manufacturing company that has designed and is producing a computer specifically for charting machine and hand knit patterns. We expect to have it ready for the U.S. market at about the middle of this year and we expect it to retail for less than \$500.00 Watch for more information regarding this clever new machine knitting tool and some other new products and services to be offered by KNITKING.



373

Party Time!

Wear this feminine Top  
to any gala affair.  
It's a Tuck and Lace Design.  
Crochet the Collar and  
make it with Cordella and  
Capriccio yarn. Sizes 6 to 12.





# 368 High Style

For now or tomorrow...

our 3-piece Suit has that expensive

look and a new shape sleeve.

Knit the Skirt and Jacket in

Stockinette stitch.

The Shell has an Eyelet Yoke.

Sizes 6 to 16. Venetia yarn.





# 367 *Dramatic and Different*

A lovely Suit has a slight flair  
to its sideways knitted Skirt.

The Fairisle Jacket with off center  
closure is an innovation and very  
flattering to most figures.

Vienna and Amore yarn.

Sizes 6 to 16.







# 378 Challenge in Color Knitting

Anyone can knit this beautiful Blouse.

Follow the directions exactly for  
delightful success. Made with our  
Viola yarn in Small and Medium Sizes.



# 371 Fashion Favorite



A Lovely Top sparkles with the addition of its own glamour Scarf and delicate embroidery on the front section.

A Lace design makes the over-sleeve.

Use Alpacana and Capriccio yarn.

Sizes 6 to 8.



# 360 A Perfect Cover-Up

Capes are always in fashion and this one  
is perfect to wear over a lovely dress  
as well as sportswear.

Knitted in simple Stockinette stitch  
with full needle Ribbing to form the hem.

The Size, Medium, the yarn, Amore.







# 366 Terrific Triangles

The mood of the day begins with an eye catching Dress. Large triangles on the front section can be knitted using the Intarsia or Short Row method... the choice is yours.  
Use our Venetia yarn.  
Sizes 6 to 16.



# 365 To Ski or Not to Ski

High on the top of the list  
of current fashion is the  
Fairisle Yoke Pullover.  
Not limited to the Ski slopes,  
he will wear it everywhere  
and love the soft texture  
of our Shetland yarn.  
Sizes 40 to 44.

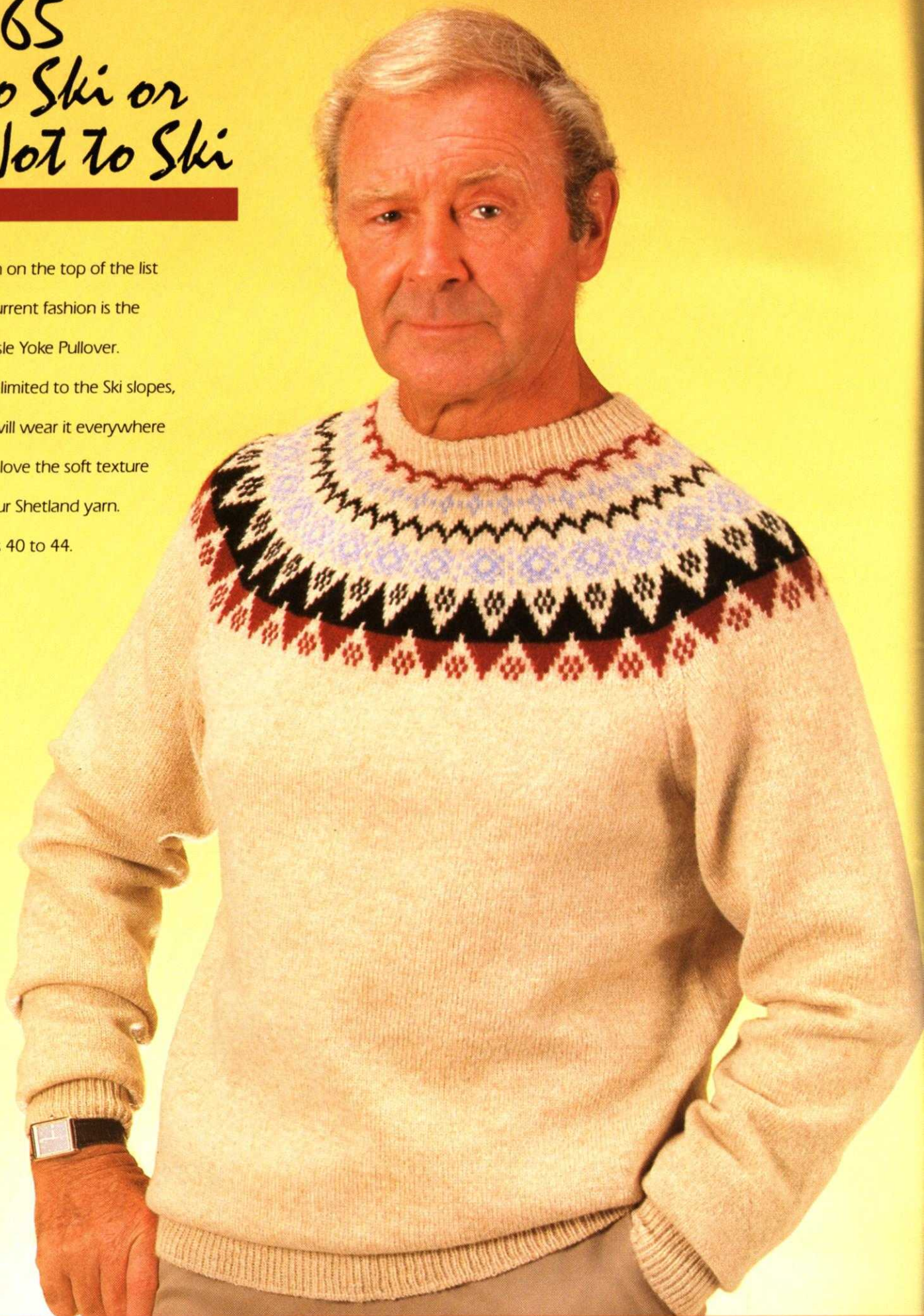



# General Instructions

## THE PRINTED INSTRUCTIONS

Follow the printed instructions or use them in combination with the Charts. Where there is any question in the instructions, you have the Charts to show you how the section will look.

Be sure to READ AHEAD so that you KNOW what to do for the size you are knitting. In the shapings, where the number of stitches are the same but the number of times different, you might find shapings like this...3 sts. 1 x (2x) [3x]—so that for the first size you will bind off 3 sts. 1x, 2nd size 3 sts. 2x, 3rd size 3 sts. 3x. Sometimes the ROWS will be different for each size—so you must watch out for different row numbers.

Shoulder and neck shapings for the back section of a garment usually are shaped at the same time—so ALWAYS WATCH for the words AT THE SAME TIME.

## HOLDING STITCHES ON THE LEFT SIDE WHILE SHAPING THE RIGHT SIDE

There are different ways to hold stitches on one side while completing the other side. Usually, we tell you to bind off the center sts. for neck and put the left side into holding position while completing the right side. The easiest way and really the best way for beginners is to take a piece of RAVEL CORD and hand knit the center neck stitches, pulling them back against the needle bed of machine to the "A" or out of work position. The stitches remain in the HOOKS of the needles so you are really only knitting them HALF WAY. With another color of Ravel Cord, knit the remaining sts. on the left side in the SAME WAY.

It is important to protect these held stitches in some way—so you can either hang a REVERSING BAR so that the EYES of the Bar go BETWEEN the Gate Pegs on the machine and that the UPPER TIPS of Bar only—show above the needle bed...OR the simplest way is to use a piece of 1 inch masking tape and GENTLY place it beneath the knitting—right below the gate pegs. Do NOT press the tape—only enough pressure to hold it in place. This will prevent the Carriage (or Slide) from marking the held section.

It is VERY IMPORTANT that you mark the PATTERN ROW where you divide for the split for NECK (or SHOULDER) shaping....If you are using a PUNCH CARD—MARK THE CARD—if you are using an ELECTRONIC machine, MARK THE DESIGN WINDOW. Also take note of the Row number for the division. When you are ready to work the left section, bring the HELD stitches back to B (working) position by pulling each end of the Ravel Cord GENTLY and rip it off—be sure to align all needles straight in the B or knitting position.

Now you are ready to REFER TO YOUR OWN INSTRUCTION MANUAL for your machine—to set the controls to begin knitting the left half. The neck stitches can be bound off after completing the right side or you can leave them in hold until each side is finished, then bind them off or remove them onto contrast waste yarn ready to be picked up for knitting a neckband or for other finishing.

## FULL FASHION DECREASING OR INCREASING

For Stockinette stitch, use the Full Fashion method for decreasing or increasing (except for regular cap shaping on sleeves where you decrease the edge stitch).

TO DECREASE: Hang the 3rd stitch onto the 2nd stitch then move the end stitches in to fill the empty needle.

TO INCREASE: Move the 2nd end stitches 1 needle outward, then pick up the 3rd stitch from the row below and hang it onto empty needle.

## PATTERN SYMBOLS

( ) Symbol for 2nd size.

[ ] Symbol for 3rd size.

There are up to 3 sizes given for Patterns in KNITKING MAGAZINE. For example, the Charts and printed instructions will show the cast-on as...124—First size. (132)—Second size. [140]—Third size.

R = ROW

◻ Needles in holding position.

⊗ Needles back into working position.

< For Short Row Knitting

## THE SAMPLE SWATCH

Before you knit any garment, you must knit a sample swatch using the yarn you have chosen for your garment. If you do not get the correct Stitch and Row Gauge as given for a Pattern in KNITKING MAGAZINE—try different tensions. If you are using the specified yarn, you should be able to get the correct gauge using one of the tensions shown. If you are using other yarns, you may have to make several swatches—but the gauge is very important.

To make a sample swatch—Cast on 60 stitches with waste yarn and knit 6 rows. Mark the tension number for your sample swatch by making holes (you can do this with a Lace Carriage or by hand), 4 transfers for Tension 4, 6 transfers for Tension 6, etc. Knit 6 more rows.

Change to garment yarn and set Counter at 0. Knit 30 rows (in Stockinette stitch or Pattern stitch—according to the garment). With contrast waste yarn knit the 10th stitch FROM EACH SIDE—by hand. Knit 30 rows. Change to waste yarn and knit 12 rows. Remove the sts. from the machine by pushing the Carriage (or Slide) across without yarn.

Pull and stretch the sample swatch both lengthwise and diagonally from corner to corner, then lengthwise again. Gently block the swatch (KNITKING PRESSING CLOTHS are great for this)—or you can allow the sample to rest several hours or even over night so that the stitches can return to their basic form. USE KNITKING CONVERTA TAPE for MEASURING YOUR SAMPLE (or the KNITKING INSTANT STITCH AND ROW GAUGE MEASURE).

If you use the Converta Tape, pull out the Tape to measure BETWEEN the 40 marked stitches in the center of your swatch. Move the red marker on the Tape so that it points to 40 stitches on the TAPE. Your stitch gauge to 2" (5 cm) will show in the RED WINDOW. To find the number of rows in 2" (5 cm), place the Tape to measure over the 60 rows, push the red marker to 60 on the Tape and your row gauge for 2" (5 cm) will show in the red window.

If you do not own a KNITKING CONVERTA TAPE or a Stitch and Row Measure, you must count the number of stitches and rows to 2" (5 cm) after marking a 2-inch square in the center of your knitting.

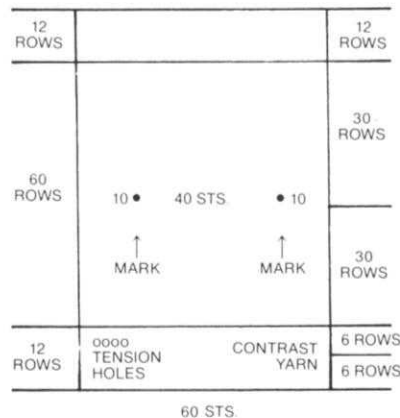

## FINISHING

Gently block all sections—For PULLOVERS, JACKETS and DRESSES: Join the front to back at shoulders and sides. Sew sleeves together and set in. Hem lower edge and sleeve edges if needed. For a double neckband or armhole, band sew 1 edge to inside and 1 to the outside of neck or armhole. For a single ribbed band, sew 1 edge to the outside of neck or armhole edge. For a cardigan or jacket with buttonholes, finish buttonholes and sew on buttons.

PANTS: Join front to back at sides. Sew inside leg seams, then join to center front and back. Make hem at waistline and insert elastic. Hem lower edge of pants' legs.

◻ Needle not used—in out of work position.

3x1

④ The number in the box is the number of Rows between shapings. The 3 x 1 above the box gives you the sts. and number of times to make the decreases (or increases)—FOR EXAMPLE: 3 x 1 over the box with 4 means—At the given Row number, °decrease 1 st. knit 4 rows° and REPEAT from ° to ° 2 times more for a total of 3 times in all. All decreasing (or increasing) WITHOUT ROW NUMBER IN BOX must be made on EVERY 2nd ROW.





# 359

NO. 359

## 3-PIECE WOMAN'S SUIT

SIZES: 6/8 (10/12) [14/16]

YARN: Venetia

GRAMS:

color 1 900 g 2 1/2 2 1/2  
(2 lb.) lb. lb.

3/4" Elastic 30 - 35"

TENSION: Mock rib Skirt  
2.2 4-5

GAUGE: 20 sts. 25 rows - 2" (5 cm)  
15 sts. 24 rows - 2" (5 cm)

**GENERAL INSTRUCTIONS:** Jacket is done with Mock Rib 4x1. Bands are stockinette; Make 2 pocket linings **FIRST**. Jacket Front, Back and Sleeves cast on waste yarn and ravel cord. Set up 4x1 Rib with 2 sts. on each side of 0 in work. Pullover in stockinette. Neck edge single crochet 1 Row, Picot 1 Row. Skirt in stockinette.

**POCKET LINING:** Open Cast on with waste yarn in 4x1 pattern over 44 needles (counting the out of work needles) 1 Row ravel cord. Knit 42 rows. Take off on waste yarn. **MAKE 2.**

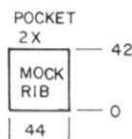

## BACK:

Open cast on with waste yarn (same as pocket) over 179 (180) [199] sts. Knit 1 row ravel cord. With garment yarn knit in pattern to row 168 (174) [180].

**SHAPE ARMHOLES:** (Count out of work needles as 1 st.) bind off 6 sts. 1x. 4 sts. 1x, 3 sts. 1x 1 st. every other row 2x and 1 st. every 4th row 5x. Knit in pattern to row 270 (280) [290].

**SHAPE SHOULDERS:** Before putting the needles into holding for short rows, fill in the empty needle as in simple increase, picking up the row below on the adjacent needle and hanging it on the empty needle. **SEE CHART.** Put into hold on each side 9 sts. 3x, 8 sts. 2x (10 sts. 1x, 9 sts. 4x) 10 sts. 4x, 9 sts. 1. Take off remaining 53 (57) [61] sts. on waste yarn.

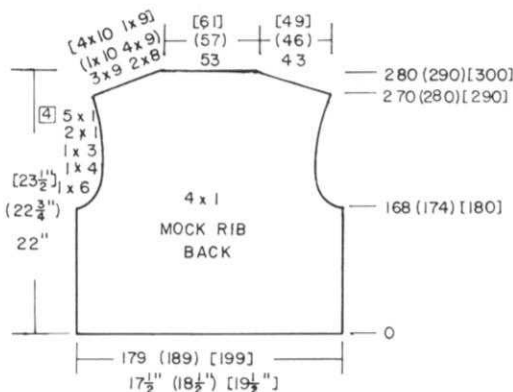

## FRONTS: Make 1, Reverse 1

Cast on with open cast on 94 (99) [104] sts. 1 row ravel cord. Knit 1 row with garment yarn. **HANG POCKET** on 6 (6 1/2) [7] Rib in from Front edge. Knit side faces you. (Match out of work needles to pocket pattern). Knit to row 42. Take off on waste yarn the 44 sts. on the garment front that match the pocket. Now hang the 44 pocket sts. on the empty needles. Knit to row 168 (174) [180]. Shape armhole and start neck shaping on the same row.

**SHAPE ARMHOLE:** (Count out of work needles as 1 st.) Bind off 6 sts. 1x, 4 sts. 1x, 3 sts. 1x, 2 sts. 1x and 1 st. 7x.

## AT THE SAME TIME:

**NECKEDGE:** 1 sts. every 3 rows

30x (1 st. 32x) [1 st. 34x.]

**SHOULDER:** As in back, fill in empty sts. before short rowing. Short row 9 sts. 3x, 8 sts. 2x (10 sts. 1x, 9 sts. 4x) [10 sts. 4x, 9 sts. 1x]. Finish at row 280 (290) [300].

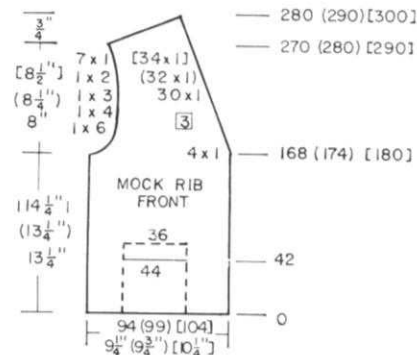

## SHELL:

**BACK:** Cast on 136 (146) [156] sts. K1 P1 Tension 0/0. Knit in rib for 36 row. Transfer ribber stitches to main bed. Change to Tension 4 - 5. Knit to row 152 (156) [160]. Increase on each side 1 st. every other row 12x. At row 176 (180) [184]. Knit straight to row 254 (262) [270]. Bind off center 42 (44) [46] sts. Put left side into hold and finish right side first. Decrease at neck edge 3 sts. 1x, and 2 sts. 1x. **AT THE SAME TIME:** shape shoulder in short rows. 15 sts. 1x, 13 sts. 3x (15 sts. 2x, 14 sts. 2x) [16 sts. 2x, 15 sts. 2x]. Turn counter back to row 254 (262) [270] and finish the left side with reverse shaping.

**FRONT:** Knit same as back to row 228 (236) [244]. Take off center sts. 20 (22) [24] on waste yarn. Put remaining sts. on left side into hold and finish the right side first. Decrease at neck edge 4 sts. 1x, 3 sts. 1x, 2 sts. 3x and 1 sts. 3x. Starting at row 254 (262) [270] shape shoulder as in Back. Return counter to 228 (236) [244] and finish the left side with reverse shaping.

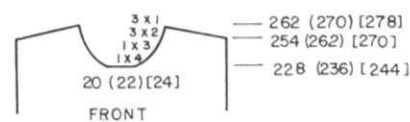
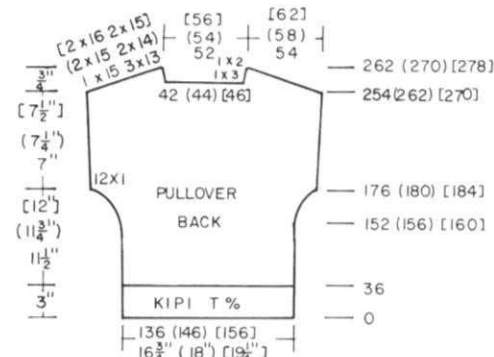

**BACK NECK BAND:** Pick up with WRONG side facing you 43 (46) [49] st.

**PART BUTTON HEM METHOD:** Knit 30 rows and hang hem. Bind off.

**BACK HEM BAND:** Pick up (as in Neck Band) 144 (151) [159] sts. Knit 30 row and hang hem. Bind off.

**FRONT HEM BANDS:** Pick up (as in Neck Band) 76 (79) [84] sts. Knit 30 rows and hang hem. Bind off.

**FRONT EDGE BANDS:** Pick up 178 (184) [190] sts. along front edge. Knit 30 rows and hang hem. Bind off.

**SLEEVE BANDS:** Pick up 60 (64) [68] sts. along cuff edge. Knit 30 rows and hang hem. Bind off.



SLEEVES: Make 2

Cast on with open cast on, 1 row ravel cord on 76 (80) [84] sts. Increase 1 st. every 5th row 25x to row 168 (174) [180].

SLEEVE CAP: Bind off 6 sts. on each side, then decrease 3 sts. every other row 2x, 1 st. every other row 5x, then 1 st. every 3 rows 22x (23x) [24x] and 1 st. every row 9x (10x), [11x]. Bind off remaining sts.

POCKET BANDS: Pick up 36 sts. from waste yarn. Using Part Button Hem method knit 30 rows and hang hem. Bind off loosely. Sew in place to front.

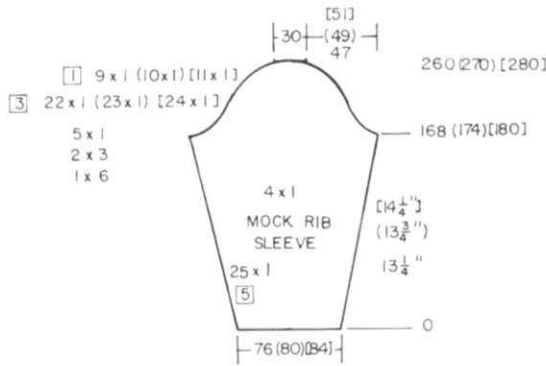

SKIRT WITH 4 PLEATS:

General Instructions: Since there are different needles used for SHORT ROWS - MARK THE NEEDLE BED - FOR A - Use X for the holding and O for returning needles - in BLACK. Do the same for B - only this time use RED MARKINGS. This will speed up the knitting time. Every other needle used for tuck stitch when needed. Begin and end skirt using contrast waste yarn.

HIP SIZE:	6/8	10/12	14/16
A Section	4x	5x	5x
B Section	1x	1x	1x
A Section	5x	5x	6x
B Section	1x	1x	1x
A Section	8x	9x	9x
B Section	1x	1x	1x
A Section	5x	5x	6x
B Section	1x	1x	1x
A Section	4x	4x	4x

Cast on 200 sts. Knit 8 rows over all needles.

WAISTBAND: Make 2

Cast on 132 (136) [140] sts. PART BUTTON HEM METHOD Lower tension and knit 24 rows. Hang hem. Then hang 1/2 of waistband, pur1 side facing you. Knit 1 row loosely and bind off.

FINISHING: Weave seam sts. held on waste yarn. Pull elastic through casing at waist.

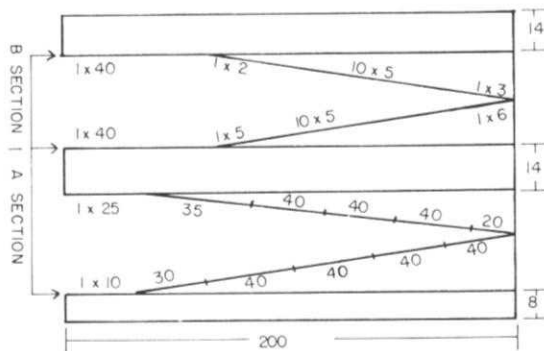
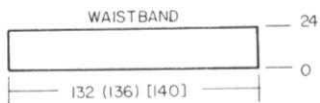

\*A:

ON THE LEFT, put into holding position, 10 needles, then 30 needles then 40 needles 3x. (40 sts. remain in work). REVERSE THE SHORT ROWS - Push back into working position, 20 sts. then 40 sts. 2 x, then 35 sts. (25 sts remain). ALL NEEDLES IN WORKING POSITION, Knit 14 rows. REPEAT FROM \* 4x more.

( SEE SIZE CHART FOR CHANGES IN SIZES.)

B:

TUCK: ON THE LEFT, put 40 sts. into holding position, knit 1 row to the left (select every other needle). Push in BOTH TUCK BUTTONS and knit 1 row to the right side. RELEASE TUCK BUTTONS. Push back 2 needles on the left into working position, knit to the left and bring 1 back into holding position. Knit to the right.

SHORT ROWS FOR PLEATS: Put into holding position, 5 sts., then 15 sts. 10x (6 sts. remain). REVERSE THE SHORT ROWS: Push back into working position 3 sts. then 15 sts. 10x, 2 sts. 1 x 40 sts. remain in holding position.

TUCK: First put 2 sts. back into work - knit 1 row to the left. Bring one needle back into holding position. Select every other needle. PUSH IN BOTH TUCK BUTTONS, knit 1 row to the right. RELEASE TUCK BUTTONS. Knit 14 rows over all needles. REPEAT FROM A plus B as SHOWN ON THE CHART FOR YOUR SIZE. YOU MUST END WITH 6 ROWS OVER ALL NEEDLES, THEN REMOVE ONTO CONTRAST YARN.



360

NO. 360

WOMAN'S CAPE

SIZE: Medium  
YARN: Amore  
GRAMS: color 1 500

TENSION: 6

GAUGE: 14 sts. 25 rows - 2" (5 cm)

ACCESSORIES: 8 buttons

GENERAL INSTRUCTIONS: For hem begin each piece with full needle rib cast on, ribber on half-pitch. Tension 5/4, with same number of stitches on ribber as on main bed. Knit circular. Knit 24 passes (12 rows).

Transfer stitches from ribber to main bed. Set Tension to 6, counter to 0 and begin knitting as charted.

Continued

help wanted

One of our teachers in the Los Angeles Center has moved up and is now working exclusively in the Magazine Department. We are looking for a replacement.

It's a 30 hours a week job. Applicants must be able to instruct on Punch Card machines Electronic machines and Bulky machines. If you are interested and think you qualify, please send resume to:

KNITKING

1128 Crenshaw Blvd., L.A. Calif. 90019



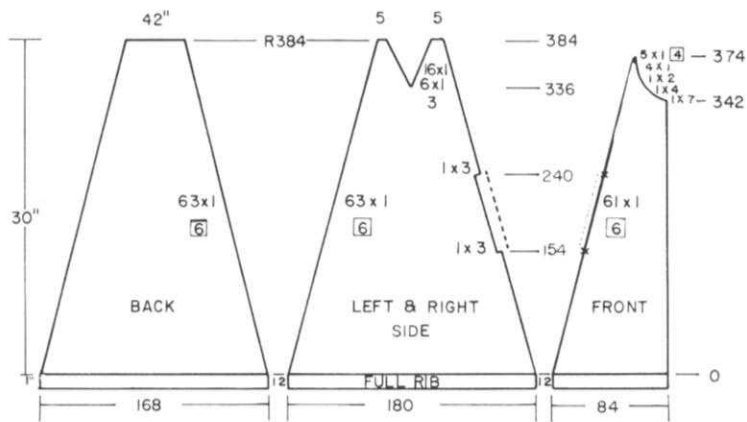

**BACK:**

Cast on 168 sts. Bgin as in general instructions. Start decreasing full fashion (move 3rd stitch to 4th stitch and move sts. over). Decrease on each side 1 st. every 6th row 63x. Knit to row 384. Take off remaining 42 sts. on waste yarn.

**LEFT AND RIGHT SIDE:** Make 1 and reverse 1

Begin as in general instructions, casting on 180 sts. on both beds. Full fashion decrease as in Back, 1 st. every 6th row 63x on each side. At the same time on right side at row 154, Bind off 3 sts. And at row 240 cast on 3 sts. For the arm slit bands. At row 336 split garment in two. Take off one side on waste yarn and finish the other side. Decrease 1 st. every 3rd row 6x, then 1 st. every other row 16x. (Remember to continue edge decreases). Take 5 sts. off on waste yarn. Reset counter to 336 and finish remaining side. Take neck stitches off on waste yarn.

**FRONT:** Make 1 and reverse 1

Begin as before, casting on 84 sts. on both beds. Decreasing on left side 1 st. every 6th row 61x. At the same time at row 342 start neck edge shaping: Bind off 7 sts. 1x, 4 sts. 1x, 2 sts. 1x, 1 st. 4x, and 1 st. every 4th row 5x. End at row 374. Make sure you mark row 154 and row 240 for slit bands.

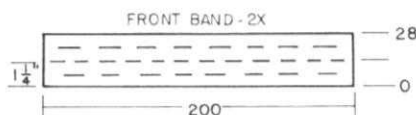

SEW ALL SHOULDER SEAMS TOGETHER

**NECK BAND:**

Cast on 126 sts. Tension 6. Knit 8 rows. Prepare Buttonhole: 4 needles in on the left side. Knit 6 rows, 1 row eyelet, Knit 6 rows, repeat buttonhole on left side. Knit 8 rows and hang hem. Hang entire neck edge, including front bands, onto needles. Knit 1 row loosely and latch off.

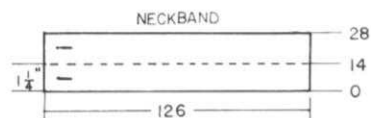

**ARMSLIT BANDS FOR SIDE PIECES:**

Cast on 49 sts. using Part Button Hem technique. Knit stockinette Tension 6 for 14 Rows. Transfer every other needle to neighboring needle, leaving empty needle in work position. Knit 14 rows. Hang hem (first row onto last row) and hang garment between rows 154 and row 240, wrong side facing you. Knit 1 row loose tension, and latch off.

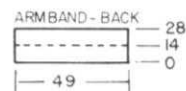

**ARMSLITS FOR FRONT:**

Cast on K1 P1 49 sts. Knit 6 rows at Tension 3/2. Transfer ribber sts. to main machine and hang Front section with purl side facing you onto main needles (between marked rows). Latch tool bind off.

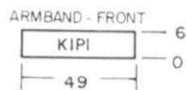

**FRONT BANDS:**

Buttonhole side as follows: Cast on 200 sts. at Tension 6. (Right side is the neck edge). Knit 8 rows. Prepare buttonholes (see Instruction manual or use alternate method). Buttonhole needles are 15th and 16th from the right, skip 18 needles. Alternate 2 buttonhole needles and 18 garment needles 6x (7 buttonholes). Knit 6 rows with garment yarn. 1 row eyelet. Knit 6 rows and repeat buttonhole row. Knit 8 rows and hang hem. Then hang Right Front of garment on to needles as armhole slit bands. Knit 1 row loosely and latch off.

Left band is 200 sts. at Tension 6. Knit 14 rows, 1 row eyelet, Knit 14 rows. Hang hem. Hang left front onto the needles as above. Knit 1 row loosely and latch off.



**KNITKING BINDERS** — Holds One Complete Year's Copies

Keep all your KnitKing Magazines together and build a beautiful library of patterns

\$5.95 ea. Available from KNITKING: 1128 Crenshaw Blvd., Los Angeles, Calif. 90019

I enclose \$ \_\_\_\_\_ for \_\_\_\_\_ Binders (Calif. residents add Sales Tax) plus \$1.25 Shipping costs. (Canada \$2.75)

Name \_\_\_\_\_

Address \_\_\_\_\_

ZIP \_\_\_\_\_













# 363

NO. 363

WOMAN'S STRIPED TOP

**SIZES:** Small Medium Large  
**YARN:** Knitking Viola  
**GRAMS:**  
 color 1 350 350 400  
 color 2 50 50 50  
 color 3 50 50 50  
 color 4 50 50 50  
 color 5 100 100 100  
**TENSION:** 10+  
**GAUGE:** 10 1/2 sts., 16 rows =  
 2" (5 cm)

**GENERAL INSTRUCTIONS:** A striped Pattern knitted sideways with variable row count. See chart for row numbers. Make Front and Back sections first. Sew shoulder seams together and pick up sleeves at shoulders. Knit from shoulder to cuff. All bands are K1 P1 Rib Tension 7/6 II.

**FRONT:**

Cast on Waste yarn 107 (111) [114] sts. MARK 46th stitch from left. Knit 11 rows, 1 row ravel cord L-R. Change to garment yarn. Knit to row 48 (54) [60] following the chart for color changes. Bind off on the right (for neck edge) 3 sts. 1x, 2 sts. every other row 3x, 1 st. every other row 2x, and 1 st. every 4th row 3x. Continue following color chart on 93 (97) [100] sts. to row 80 (88) [96]. Reverse color pattern to Row 90 (100) [110]. Now increase for other side of the neck, reversing the numbers. Knit in color pattern to row 160 (176) [192]. Take off onto waste yarn.

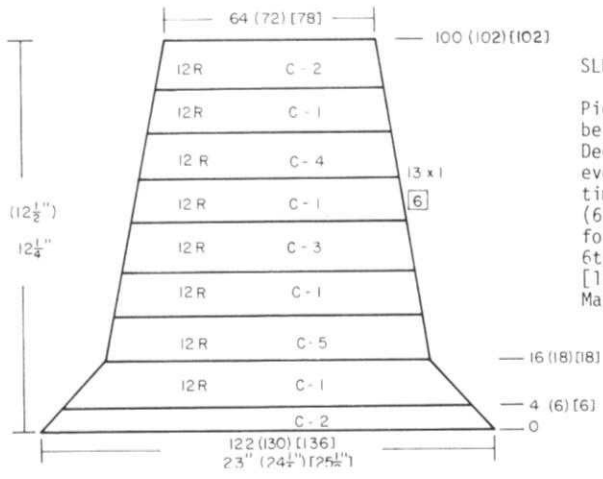
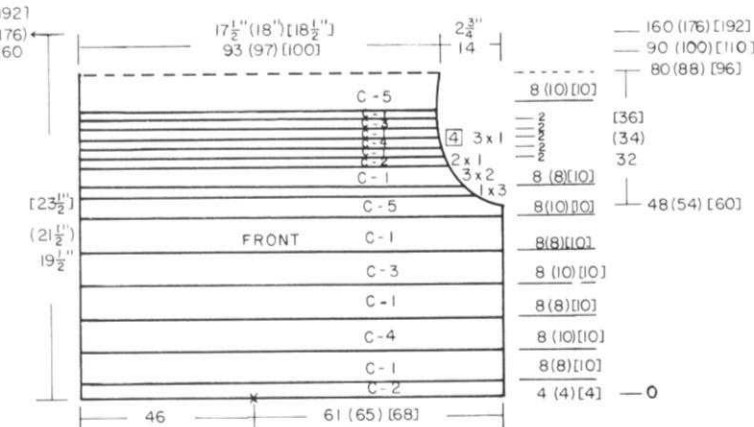

**SLEEVES:**

Pick up 122 (130) [136] sts. between marks with Color 2. Decrease ON EACH SIDE 1 st. every other row 8x. At the same time change to Color 1 after Row 4 (6) [6]. Then following chart for color, decrease 1 st. every 6th row 13x. At Row 100 (102) [102] take off onto waste yarn. Make second sleeve the same way.

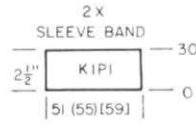

**SLEEVE BANDS: Make 2**

Cast on K1 P1 Color 1, 51 (55) [59] sts. Rib for 30 rows. Transfer ribber sts. to main machine and hang the bottom edges of sleeves onto these needles, decreasing evenly across the row. (Every 3rd or 4th stitch is double). Purl side facing you. Knit 1 row Tension 10+ and bind off loosely.

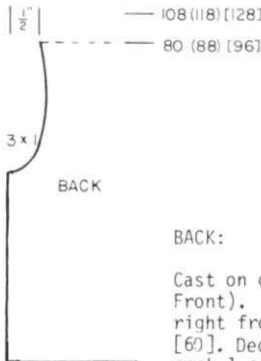

**BACK:**

Cast on onto waste yarn (as with Front). MARK 47th stitch from right front to row 48 (54) [60]. Decrease for the back of neck 1 st. every other row 3x. Then knit in pattern to row 108 (118) [128] and increase reversing the numbers. Continue in color pattern and knit to Row 160 (176) [192]. Take off onto waste yarn.

**SEAM AND MAKE NECKBAND**

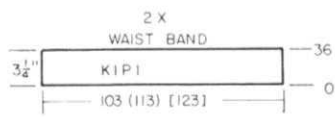

**WAISTBAND: Make 2**

Cast on 103 (113) [123] sts. K1 P1 Color 1. Knit 36 rows. Transfer sts. from ribber to main bed. Hang Waist edge of front or back, purl side facing you, onto these needles. AND KNIT THIS ROW MANUALLY, pulling the loops through to make large sts. Now bind off loosely.



**NECKBAND:**

Cast on 118 (122) [126] sts., K1 P1 Rib (See Instructions). Knit 8 rows, Color 1. Transfer rib sts. to main machine and hang the neckline, purl side facing you. Knit 1 row Tension 10+, and Bind off loosely.

**SEAM BOTH SHOULDERS TOGETHER**



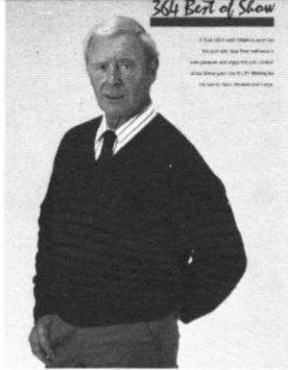

# 364

NO. 364

**MAN'S TOP (TUCK - STRIPES)**

**SIZES:** Medium Large  
**YARN:** Knitting Show  
**GRAMS:**  
 color 1 200 200  
 color 2 200 200  
**TENSION:** 3 - 3.2  
**GAUGE:** 13 sts. 44 rows = 2" (5 cm)

**GENERAL INSTRUCTIONS:** Tuck and stripe pattern. Purl side is right side. K1 P1 rib Tension 0/0.

**BACK:**

Cast on 140 (150) sts. K1 P1 rib Tension 0/0 and knit 46 rows. Turn counter to 0. Transfer ribber sts to main machine. Garment Tension. Set the card. If you are using the KHC color changer SFT KC on the LEFT. (This is opposite of Instruction Manual). If you are not using color changer set KC on the right. Push in Tuck Buttons on row after setting KC. Now follow the color stripe pattern as follows:

Color	Medium	Large
1	24 Rows	24 Rows
2	2	2
1	22	22
2	2	4
1	20	20
2	4	6
1	18	18
2	6	8
1	16	16
2	8	10
1	14	14
2	10	12
1	12	12
2	12	14
1	10	10
2	14	16
1	8	8
2	16	18
1	6	6
2	18	20
1	4	4
2	20	22
1	2	2
	<u>268</u>	<u>288</u>

At row 270 (290) mark for armhole. Continue Tuck Pattern in color 2 only. At the same time increase on each side 1 st. every 24th row 7x to row 460 (490). Bind off on each side for shoulders 6 sts. every other row 6x (6 sts. 9x), 5 sts. every other row 4x (5 sts. 1x). Bind off 42 (46) sts. at neck edge.

**FRONT:**

Same as Back to row 280 (300). Divide garment in the middle and place left side into hold. Knit each st. on left with ravel cord and push back into A position. Place masking tape lightly over garment under the gate pegs (to avoid marking the wool).. Mark your card. Now shape "V" neck, decreasing at neck edge 1 st. every 8th row 21x (1st. 23x). Continue shaping neck edge, at row 460 (490) shape shoulder as in Back. Pull ravel cord gently to bring Left side needles back into work position. Remove tape. Turn card back to the marked row. Push in Both PART Buttons, lock your card and move your carriage from L-R without yarn. Now unlock your card needles are set out in pattern. Release Both Part Buttons, Push in Tuck Buttons and put yarn in yarn feeder. Set counter at 280 (300) and finish left side, reversing shaping.

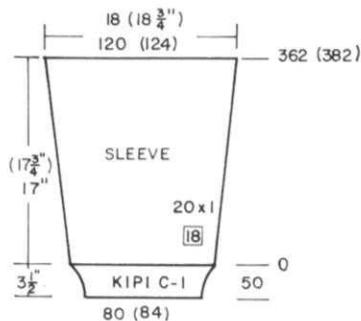
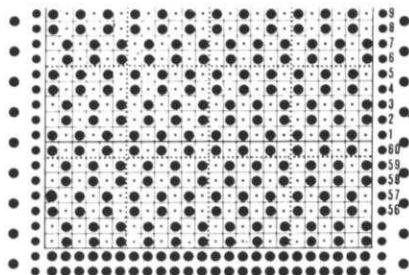
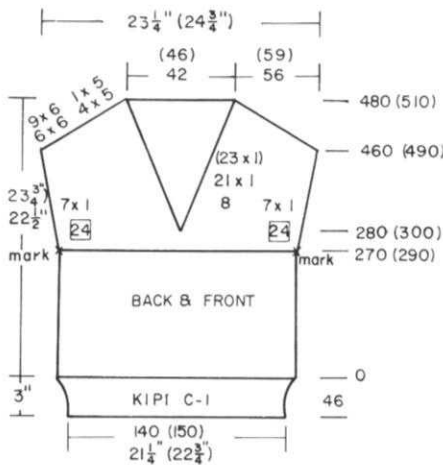

**SLEEVES: Make 2**

Cast on 80 (84) K1 P1 Tension 0/0 Color 1. Knit to Row 50. Transfer ribber sts. to main machine. Set counter to 0. Change to garment Tension. Set card and KC same as Back. Start Tuck and stripe pattern.

**Tucking for Sleeve**

Color	Medium	Large
1	30 Rows	30 Rows
2	2	2
1	28	28
2	2	2
1	26	26
2	2	2
	<u>90</u>	<u>90</u>

After Row 90 follow color chart for back and front.

90	90
268	288
358 Rows	378 Rows

At the same time, increase on each side 1 st. every 18th row 20x. After Row 358 (378), knit 3 rows in Color 2. Release KC and Tuck Buttons and Knit 1 row plain. Bind off loosely.

**SEW ONE SHOULDER SEAM TOGETHER**

**NECK BAND: 2 Sections**

Cast on 42 (46) + 80 (84) with waste yarn (one piece 42 (46) is back of neck). Knit 11 rows, 1 row Ravel cord L-R. Change to garment yarn Color 2, Tension 2. Knit 16 rows, at the same time on the right side decrease 1 st. full fashion every other row 7x. Knit 1 row Tuck (turning row). Increase one stitch every other row 7x full fashion on right to Row 34. Take off onto waste yarn.

**SECOND SECTION:** Cast on 80 (84) sts. same method. Knit increases and decreases on the left. Hang bands back on the machine with neck edge and bind off loosely or hand finish. Stitch points together carefully.

**PUT SECOND SHOULDER TOGETHER**

Hang sleeves between marks and sew in place.

Finish underarm seams.



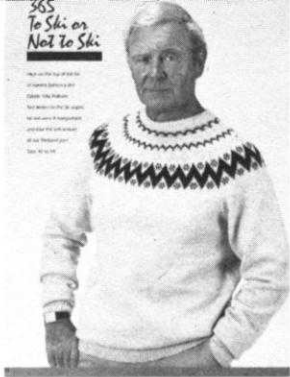

# 365

SLEEVES: Make 2

Cast on 76 (78) [80] sts. with Color 1, K1 P1, Tension 2/2 II, Rib 36 rows. Transfer ribber stitches to main bed, change to garment tension. Drop ribber and with Color 1, increase each side, 1 st. every 6th row 16x (1 st. every 6th row 16x) [1 st. every 7th row 15x]. Then increase 1 st. every 7th row 16x. for all sizes. Knit straight to Row 252 (254) [258]. Bind off 10 sts. on each side. Then decrease full fashion on each side 1 st. every other row 18x (21x) [23x]. Take remaining 84 (78) [76] sts. off onto waste yarn.

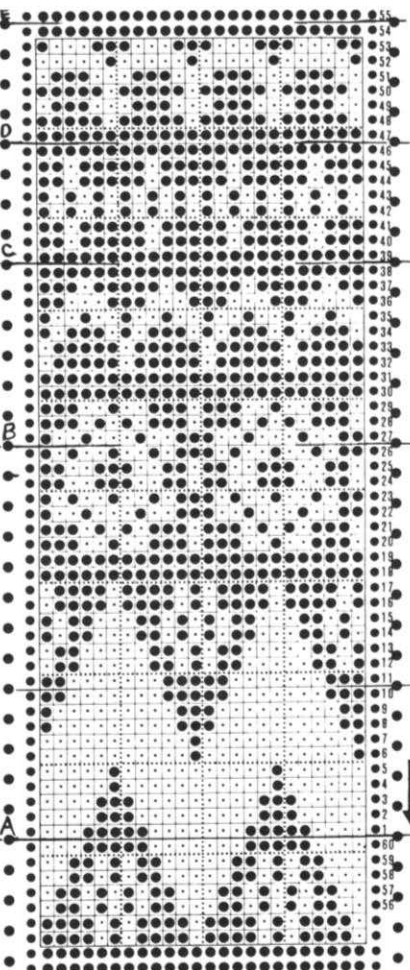
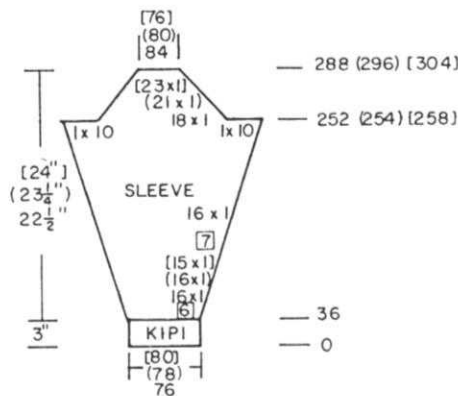

YOKE: Make 2

Note changes for secondary colors on Pattern Card. With Contrast Waste yarn, Cast on 194 sts. all sizes. After knitting 11 rows, knit 1 row Rave<sup>1</sup> Cord.

Put Colors 2, 3 and 4 in Color Changer. Set Pattern Card. Knit 1 row L-R. Set KC on right (see KHC color changer instructions). Knit 1 row R-L with Color 1. Pattern is now set for A section. Pick up Color 2. Knit 10 rows, change to Color 3. Knit to row 24. Remove Color 3, Knit 1 row L-R. Color 1 only, take off Color 1 from yarn feeder. (Don't cut yarn). Release KC. Feed waste yarn in A feeder. Knit 12 rows (not counted). Remove from machine. Decrease as follows: Leave 162 needles in work, push back remaining needles. Working from right side, hang sts. back on needles, doubling up the 3rd and 4th st. 1x, and the 5th and 6th st. 31x. Bring all 162 sts. into E position. Remove waste yarn. Feed Color 1. B Feeder set KC. Knit 1 row R-L, Pattern now set for B section.

Knit B section to row 37, Color 1 on right. Remove from machine with same procedure. Leave 138 needles on main bed in work, push back remaining needles. Working from right, hang 6th and 7th sts. double 6x, 5th and 6th double 12x, 6th and 7th double 6x. Bring these 138 needles into E position and Knit R-L 1 row. Section C now set up. Knit Section C to row 45. Color 1 on right.

Follow same procedure as above. Hang 106 sts: 4th and 5th sts. 3x, 3rd and 4th sts. 26x and 4th and 5th sts. 3x. Knit to row 53.

Follow same procedure, decreasing 4th and 5th 4x, 3rd and 4th 18x, 4th and 5th sts. 2x. 82 sts. on machine. Knit to Row 61. Follow same procedure, bring out 74 needles. Hang 9th and 10th 1x, 8th and 9th 7x. Knit 1 row Color 1. No pattern. Take off onto waste yarn. Make second yoke same.

SEW ONE SHOULDER SEAM

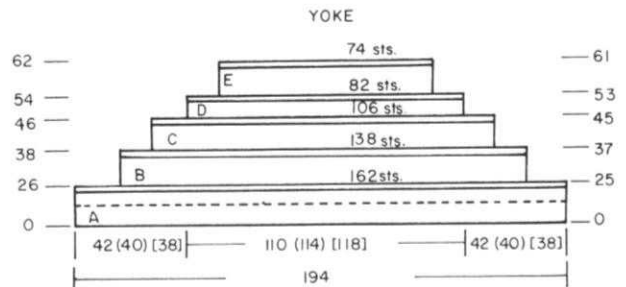

NORWEGIAN PATTERN with Color Changer

Yarn Feeder A	Yarn Feeder B	Rows
C - 2	C - 1	10
C - 3	C - 1	14
	C - 1	2
C - 4	C - 1	10
	C - 1	2
C - 3	C - 1	6
	C - 1	2
C - 4	C - 1	6
	C - 1	2
C - 2	C - 1	6
	C - 1	2

NO. 365

MAN'S SKI SWEATER

SIZES: 40 (42) [44]  
 YARN: Knitting Shetland  
 GRAMS:  
 color 1 1 lb. all sizes  
 color 2 small amount  
 color 3 " "  
 color 4 " "  
 TENSION: 6 - 7  
 GAUGE: 16 sts. 22 rows = 2" (5 cm)

Stockinette stitch with Fairisle yoke. Use color changer. Bands are K1 P1 ribbing. Cuffs Tension 2/2 II, Neckband follow instructions.  
 Make Front, Back, and both sleeves before starting yoke.  
 YOKE: The two rows of plain knitting between pattern rows is the area of decrease.

BACK AND FRONT:

Cast on 166 (176) [184] sts. with Color 1, K1 P1, Tension 2/2 II, Rib 36 rows. Transfer ribber stitches to main bed, change garment Tension to 6. Drop ribber and continue straight knitting to Row 224 (all sizes). Bind off 10 sts. on each side. Then decrease 1 st. full fashion every other row 18x (21x) [23x] to Row 260 (266) [270]. Remove remaining 110 (114) [118] sts. on waste yarn.

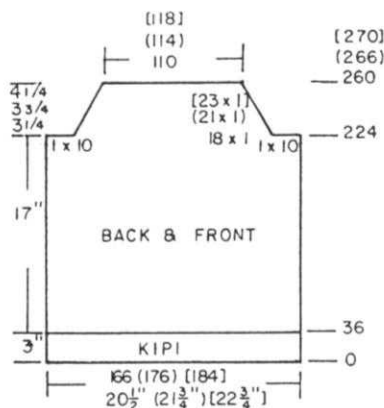

Continued



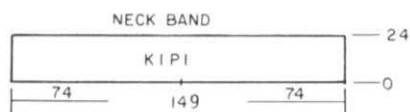

**NECKBAND:**

Cast on 149 sts. with Color 1, K1 P1 rib, Tension 0/0 II. Knit 1 row L-R, hang cast on comb. NO SELVAGE. Set Tension to 4/4. Knit 4 rows at Tension 4/4, 4 rows at Tension 3/3, 8 rows at Tension 2/2, 4 rows at Tension 3/3, and 4 rows Tension 4/4. Transfer Ribber st. to main bed. Drop ribber, remove cast on comb. Hang each loop from 1st row onto main bed needles. NOW hang neck edge sts. of garment onto same needles, wrong side facing you. Knit 1 row Tension 10 and crochet bind off (without yarn).

**FINISHING:**

Sew up second shoulder seam and neck seam. Sew armhole section to bodice. Then weave entire section to yoke. Lastly, weave underarm seam from waist to cuff matching armhole seams.

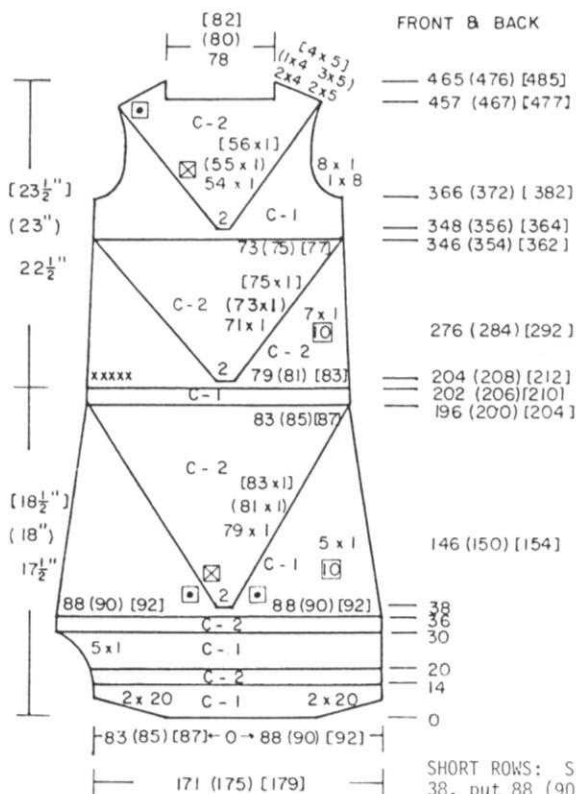

**FRONT:**

Cast-on waste yarn 171 (175) [179] sts. See chart for number of sts. each side of 0. Knit 11 rows, 1 row of ravel cord. Knit from L-R. Change to garment yarn, Color 1 and knit 2 rows. Carriage on right. Holding Cam Lever (HCL) on "H". Pull out 40 sts. on left into holding position. Knit 1 row R-L and wrap inside holding needle. Pull out 40 sts. on right side and knit 1 row L-R and wrap. Push into work position 20 sts. on side OPPOSITE carriage every row for next four rows. Knit to Row 14. Hang lining A (purl side facing you). Change to Color 2 and knit to Row 20. Pick up the other edge of Lining A, change to Color 1 and continue to Row 30. AT THE SAME TIME increase 1 st. every other row 5x on left side. At Row 30, Hang lining piece "B", change to Color 2 and knit to Row 36. Change to Color 1 and hang edge sts. of Lining B. Knit 2 rows in Color 1.

**SHORT ROWS:** Starting at Row 38, put 88 (90) [92] and 2 center sts. into holding position. Using Color 1, knit putting 1 st. into hold on left of working needles every other row 79x (81x) [83x]. AT ROW 146 (150) [154] start decreasing 1 st. every 10th row 5x on the right. Finish at Row 196 (200) [204]. Cut Yarn. Attach on left side. Move carriage to left side. Turn counter back to 38 and push into working position 88 (90) [92] sts. on left. Reverse pattern. Cut Yarn, move carriage to right side. Push 2 center sts. into working position. Attach Color 2. Using reverse short rows, push back into work 1 st. on side opposite carriage every row. Finish at Row 196 (200) [204]. Hang Lining piece "C". Attach Color 1. Knit to Row 202 (206) [210] and hang lining. Knit 1 row R-L. Now, leaving the edge sts. single, double up the next 10 sts. on each side. DON'T decrease across the row. It ruins the pattern. Using SHORT ROW method, follow the chart for the number of sts. At Row 276 (284) [292], start decreasing 1 st. every 10th row 7x.



**366**

NO. 366

WOMAN'S DRESS WITH TRIANGLES

SIZES: 6/8 (10/12) [14/16]

YARN: Venetia

GRAMS:

color 1 454 (454) [454]

1 lb.

color 2 226 (226) [226]

8 oz.

TENSION: 5

GAUGE: 16 sts. 24 rows = 2 in. (5 cm)

**GENERAL INSTRUCTIONS:** Before making the body, make 2 of Lining pieces A, B and C. (See chart). Start on waste yarn. Garment Tension. Knit in Color 1. Finish onto waste yarn. Instructions for hanging lining pieces in FRONT INSTRUCTIONS.

**NOTE:** Hemline shaping is different on the left side of the Front (for slit). Reverse for Back. Use short row method or Intarsia method for Front Pattern. Sleeves have keyhole shaping for cap.

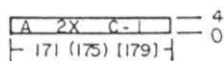
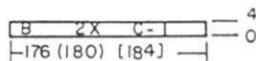
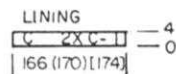

**ARMHOLE:** At Row 366 (372) [382] start armhole. Bind off 8 sts. 1x, decrease 1 st. every other row 8x. Knit to Row 457 (467) [477]. Put 18 (19) [20] sts. on left into hold or on waste yarn. Take off center 78 (80) [82] sts. on waste yarn and finish right shoulder first. Using short row method, put 5 sts. into hold 2x, 4 sts. 2x. Take off onto waste yarn. Pick up Left shoulder. Repeat shaping in reverse. Finish at Row 465 (476) [485].



BACK:

Hang linings as on front. No design. Plain stockinette. Knit to 456 (466) [476]. SHOULDER SHAPING: 3 sts. 6x (3 sts. 5x, 4 st. 1x) [3 st. 4x, 4 st. 2x.] AT THE SAME TIME: at Row 460 (470) [480], take off center 78 (80) [82] on waste yarn. Put left side on Hold and finish right side short rows. Now finish left side short rows.

SLEEVES: Make 2

Cast on 118 (120) [122]. Use PART BUTTON HEM (see Practical Hints). Hang hem at Row 20. Knit to Row 38 (40) [42]. Bind off 8 sts. on each side. Decrease 1 st. every 3rd row 20x. At Row 98 (100) [102] bind off 10 center sts. Put left side on hold or waste yarn. Decrease 1 st. every other row 5x on the left. Knit to Row 116 (120) [124]. Then Increase on left side 1 st. every other row 5x and decrease on right side 1 st. every other row 5x. End at Row 128 (132) [134]. Take off on waste yarn. Turn counter back to Row 98 (100) [102] and reverse left side of sleeve shaping.

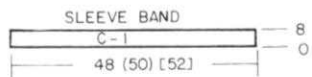
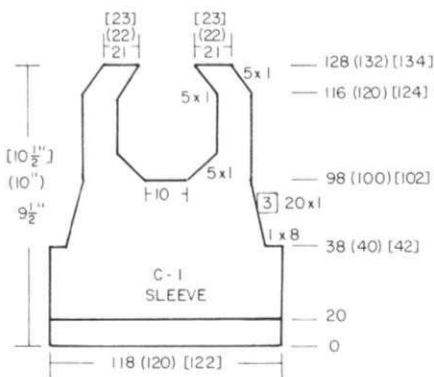
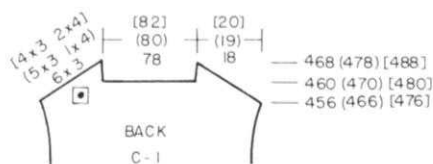

SLEEVE BAND FOR KEYHOLE OPENING: Make 2

Cast on 48 (50) [52] sts. PART BUTTON HEM method. Color 1. Knit 8 rows. Hang hem, purl side facing you. Pick up sleeve cap opening edge and hang onto hem. Bind off.

NECK BAND

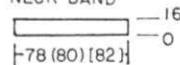

NECK BAND: Make 2

Cast on 78 (80) [82] sts. PART BUTTON HEM method. Hang hem. Then hang neck sts., purl side facing you. Knit 1 row, Tension 8. Bind off loosely.

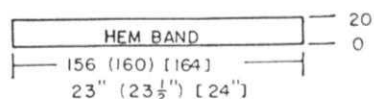

HEM BAND: Make 2

Cast on 156 (160) [164] PART BUTTON HEM. Knit 20 rows, garment Tension. Hang Hem. Hang bottom edge of dress (without slit) on top of hem, purl side facing you. Decreasing evenly across Row. Bind off.

SEW GARMENT SIDE SEAMS TOGETHER

SLIT BAND: Make 1

Cast on 48 sts. Part Button Hem Knit 8 rows. Hang hem, purl side facing you and pick up slit from front edge to back edge. Bind off.

367  
Dramatic  
and Different



367

NO. 367

2-PIECE WOMAN'S SUIT

SIZES: 6/8 (10/12) [14/16]

YARN: Vienna and Amore

GRAMS:  
color 1 Vienna 600 (650) [650]  
color 2 Amore 200 (200) [200]

TENSION: Fairisle: 5

GAUGE: 16 sts. 22 rows

TENSION: Skirt: 4.1 Stockinette

GAUGE: 14 st. 25 rows

5 Buttons

3/4" wide elastic 30-35" long

GENERAL INSTRUCTIONS: FAIRISLE pattern (see punch card). 910 copy the whole card. Bands are stockinette in Tension 3.1.

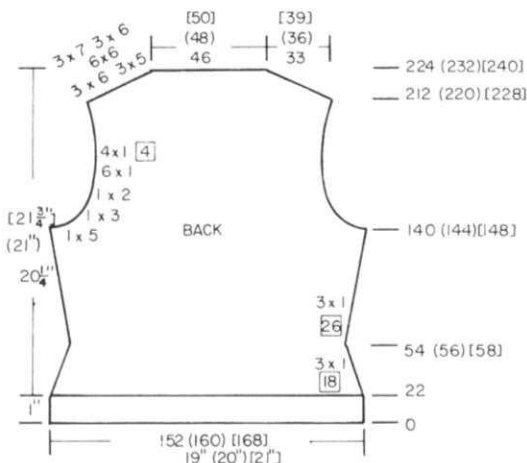

JACKET BACK:

Cast on 152 (160) [168]. Every other needle into "D" position, PUSH IN BOTH PART BUTTONS, Knit 1 row R-L, drop cast on comb. RELEASE both part buttons. Knit at Tension 3.1 to Row 22. Bring opposite needle from 1st row into "D" position and hang hem. Change Tension to 5, set punch card. Knit R-L. Now KC. Knit 1 row to right and put Color 2 into B feeder. Push card to advance. Decrease on each side 1 st. every 18th row 3x. Knit to Row 54 (56) [58]. Now increase 1 st. every 26th row 3x. At Row 140 (144) [148] begin armhole shaping. Bind off 5 sts. 1x, 3 sts. 1x, 2 sts. 1x, 1 st. 6x and 1 st. every 4th row 4x, on each side. At Row 212 (220) [228], start SHOULDER SHAPING. Use short row method. Put into Hold 6 sts. 3x, 5 sts. 3x (6 sts. 6x) [7 sts. 3x, 6 sts. 3x] on each side. Take off 33 (36) [39] shoulder sts. on waste yarn. Take off 46 (48) [50] neck sts. on waste yarn.

Continued



LEFT FRONT:

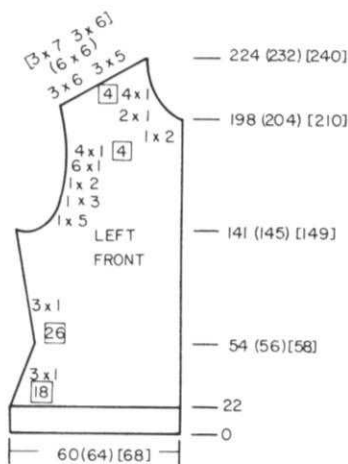

Cast on 60 (64) [68] sts. Follow chart. Decrease 1 st. every 18th row 3x, on Left side only. Shaping the same as the back only on the left side to Row 198 (204) [210]. Decrease on the right (neck edge) 2 sts. 1x, 1 st. 2x and 1 st. 4x every 4th row. Start shaping shoulders at Row 212 (220) [228] on the left side the same as for back.

SEW SHOULDER SEAMS TOGETHER

NECKBAND:

Cast on 134 (140) [146] sts. with Part Button Hem Method. Knit Tension 4 to row 4, Tension 3.2 to Row 8, Tension 3.1 to Row 10, Tension 3 to row 14, Tension 3.1 to row 16, Tension 3.2 to Row 18 and Tension 4 to Row 22. Hang Hem. Pick up neckline sts. Knit 1 row and bind off loosely.

RIGHT FRONT:

Cast on 100 (104) [108] sts. (same method as Back.) Shape front on the right side following chart to Row 191 (197) [203]. Shape neck edge at the left. Bind off 29 (30) [31] sts. Use short row method put into hold on the left 7 sts. 1x, 4 sts. 1x, 2 sts. 1x, 1 st. 1x and then decrease 1 st. every 4th row 4x. AT THE SAME TIME ON THE RIGHT starting on Row 212 (220) [228] shape shoulder the same as back.

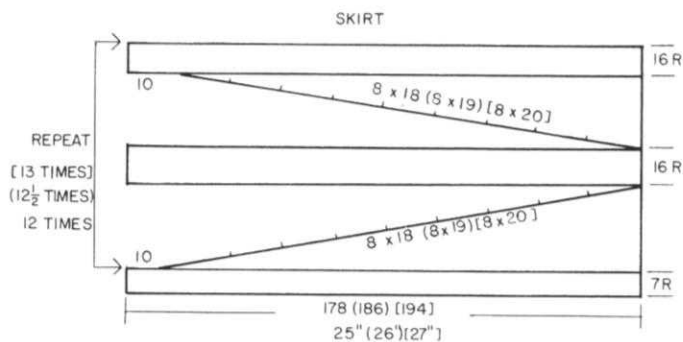
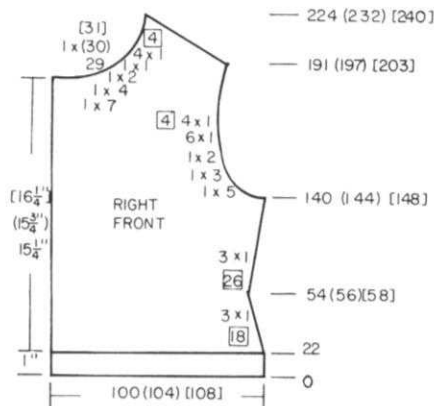

SKIRT: Slight Flair

Cast on 178 (186) [194] with waste yarn. Knit 12 rows, 1 row Ravel cord R-L. Change to garment yarn Tension 4.1, knit 7 rows. \*Holding Cam Lever on "H". Carriage on right, put Left side 10 needles into Hold position Knit 1 row R-L and wrap the inside needle. Knit 1 row L-R. Continue short rowing 18 sts. 8x (19 sts. 8x) [20 sts. 8x]. 24 sts. will remain at right side. Release "H" and knit 16 rows. Bring all needles back into Holding position, holding Cam Lever on "H". And right hand 24 needles in working position. Knit 1 row R-L wrapping inside Holding needle. Knit 1 row L-R. Now put back into work every other row, 18 sts. 8x (19 sts. 8x) [20 sts. 8x] and 10 sts 1x (reverse short rows). Knit 16 rows. Repeat from \* 12 times (12 1/2 times) [13 times], ending with 8 rows knit. Take off onto waste yarn. DON'T leave Seam together yet.

RIGHT FRONT BAND:

Cast on with Part Button Hem Method 164 (168) [172] sts. Tension 4. Knit 6 rows. Counting from the right side, put 3rd st. onto the 2nd needle and the 4th st. onto the 5th needle, (leave needles in work position). 29th st. on 28th needle and 30th st. on 31 needle. Repeat buttonholes with 24 sts. between across row for a total of 5 buttonholes. Knit 1 row R-L. With transfer tool twist the left st. of buttonholes to form an E. Knit to Row 10. Change to Tension 3. Knit to Row 14 and change back to Tension 4. At Row 16 repeat buttonhole row. Knit to Row 22 and hang the hem. NOW pick up the front edge of garment, wrong side facing you and hang on top of the band sts. Knit 1 row loosely and Bind off.

LEFT FRONT BAND:

Cast on 168 (172) [176] sts., Knit in stockinette Tension 4 to Row 10, Tension 3 to Row 14, Tension 4 to Row 22, and hang hem. Pick up Left Front, wrong side facing you, same as right front.

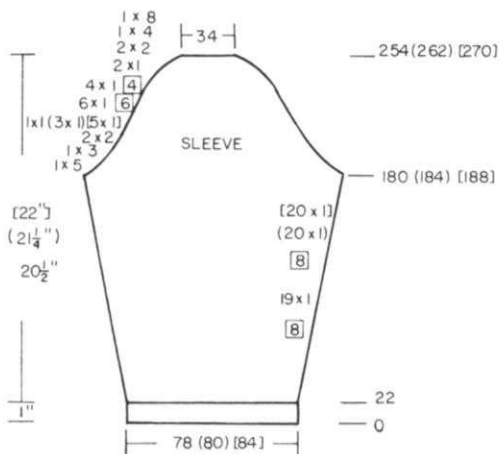

SLEEVES: Make 2

Cast on 78 (80) [84] sts. (same method as Back). Knit 22 rows, hang hem. Continue in Fairisle, increasing 1 st. every 8th row 19x, (1 st. every 8th row 20x) [1 st. every 8th row 20x]. Knit to Row 180 (184) [188]. SHAPE CAP: Bind off on each side 5 sts. 1x, 3 sts. 1x, 2 sts. 2x then 1 st. 1x, (1 st. 3x) [1 st. 5x]. For all sizes bind off 1 st. every 6th row 6x, 1 st. every 4th row 4x, 1 st. every other row 2x, 2 sts. every other row 2x, 4 sts. every other row 1x, then 8 sts. every other row 1x. Bind off remaining 34 sts.

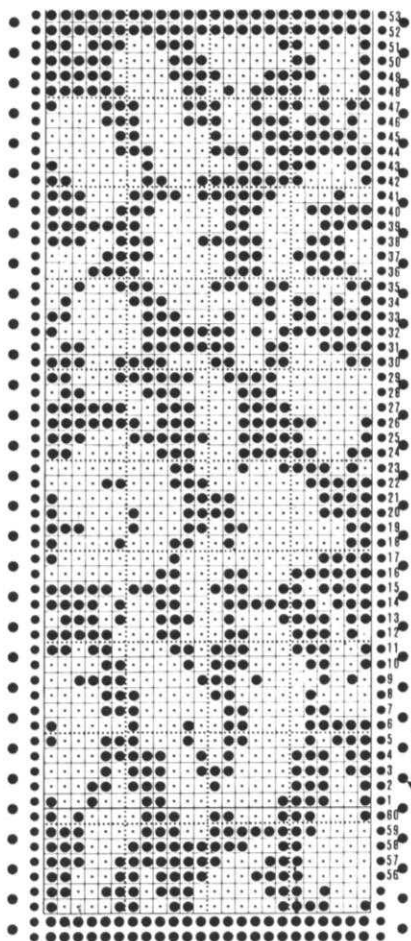



WAISTBAND: Make 2

Pick up from 1/2 waist edge (wrong side facing you) 130 (136) [142] sts. Knit 1 row. Hang cast on comb. Part Button Hem method. Knit 22 rows Tension 3.1. Hang Hem and bind off loosely.

WEAVE SKIRT EDGES TOGETHER

Hem: 1 row single crochet around edge.

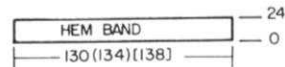
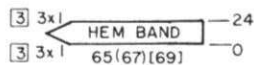

SLEEVES:

OPEN CAST ON same as the back. 112 (116) [120] sts. After waste knitting, change to garment yarn and put counter at 0. WORK SHORT ROWS, same method as Jacket Back. Put 50 sts. opposite carriage into holding position before knitting the next 2 rows. Bring back into working position 5 sts. 10x ON EACH SIDE. Knit to Row 30 (32) [34].  
SHAPE CAP: ON EACH SIDE, bind off 9 sts. then ON EACH SIDE, decrease 1 st. every 3rd row 20x. Then ON EVERY 2nd row ON EACH SIDE, decrease 1 st. 2x (4x) [6x]. WORK SHORT ROWS ON EACH SIDE. ON OPPOSITE SIDE OF CARRIAGE, put into holding position 2 sts. 10x on each side. Bring all the needles into working position and bind off.

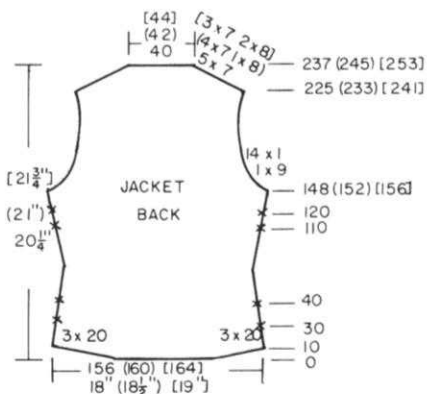
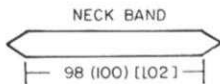
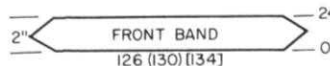
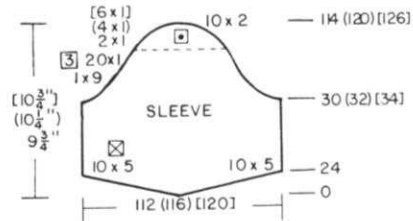

JACKET BACK:

With contrast waste yarn, cast on 156 (160) [164] sts. After knitting 9 rows, work 1 row with Ravel cord to the right side. Put Counter at 0 and change to garment yarn. Knit 2 Rows, then Put into holding position 60 sts. on Left Knit 1 Row R-L. Put 60 sts. in Hold on Right side. Knit Back. Now on OPPOSITE SIDE OF CARRIAGE, bring back into working position, 20 sts. 3x ON EACH SIDE. Decrease 1 st. after Rows 30 and 40, on Each Side. Continue in Stockinette stitch. Increase 1 st. on Each Side at Rows 110 and 120. At Row 148, (152) [156].  
SHAPE ARMHOLE: ON EACH SIDE, bind off 9 sts. 1x, 1 st. 14x. After Row 225 (233) [241].  
SHAPE SHOULDER: ON EACH SIDE, bind off.  
7 sts. 5x. (8 sts. 1x, 7 sts. 4x) [8 sts. 2x, 7 sts. 3x]. After Row 237 (245) [253], bind off the remaining sts.

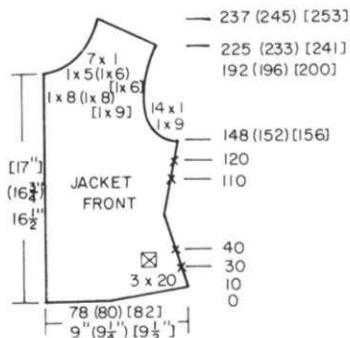

JACKET RIGHT FRONT: Make 1, reverse 1

Use OPEN CAST ON same as you did for the back - 78 (80) [82] sts. Make the Short Rows on the right (left for 2nd section) and the decreases on the right after Rows 30 and 40. ON SIDE EDGE increase 1 st. after Rows 110 and 120.  
After Row 148 (152) [156] SHAPE ARMHOLE same as the back. After Row 191 (195) [199], SHAPE NECK. Bind off.  
8 (8) [9] sts. 1x, 5 (6) [6] sts. 1x then 1 st. 7x for all sizes AND AFTER ROW 225 (233) [241] SHAPE SHOULDER same as the back.

368 High Style

For Size 6/8 (10/2) [14/16]  
Use Right Side for the Top and  
Use Left Side for the Skirt and  
Use Middle Side for the  
Sleeves and the  
Waistband on Skirt.



368

NO. 368

WOMAN'S 3-PIECE SUIT

SIZES: 6/8 (10/2) [14/16]  
YARN: Venetia  
AMOUNT: 2 lbs. for all sizes.  
TENSION: 5.1 to 6  
GAUGE: 17 sts. 23 rows = 2" (5 cm)

Jacket and Skirt is Stockinette stitch. The Shell is Stockinette stitch with Lace Yoke. Use K1 P1 Ribbing for waistband on skirt. Punch Card.

FINISHING: See General Instructions. Gather sleeve at shoulder then pin and sew into armhole. With double strands of yarn, work 1 row single crochet around neck and armholes of Shell.

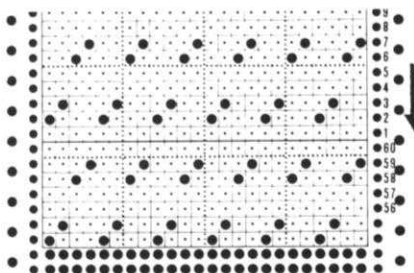

Continued



**SKIRT BACK:**

OPEN CAST ON same as the back. 180 (184) [188] sts. After waste knitting, change to garment yarn and put counter at 0. WORK SHORT ROWS. ON OPPOSITE SIDE OF CARRIAGE, put 75 sts. into holding position before knitting the next 2 rows. ON OPPOSITE SIDE OF CARRIAGE, bring back into working position 25 sts. 3x ON EACH SIDE. Knit to Row 172 (180) [188]. ON EACH SIDE, decrease 1 st. every 10th row 10x. After Row 272 (280) [288], remove onto contrast waste yarn.

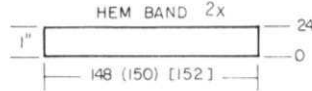
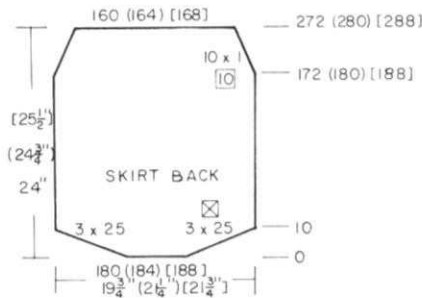

**SKIRT WAISTBAND FOR BACK:**

Bring into working position 118 (120) [122] needles. With wrong side facing you, hang the open sts. of skirt waist onto these needles, decreasing 42 (44) [46] sts. evenly across. With Tension 5, knit 30 rows Stockinette st. Hang the hem and bind off loosely.

**BAND FOR LOWER EDGE OF SKIRT BACK:**

Bring 148 (150) [152] needles into working position. With wrong side facing you, hang the open sts. of lower edge onto these needles, decreasing 32 (34) [36] sts. evenly across. Knit 24 rows with Tension 5. Hang the hem and bind off.

**SKIRT FRONT:**

Work the front the same as the back to Row 272 (280) [288]. MARK 0 then LEFT 40 and 70 needles and RIGHT 40 and 70 needles. Remove onto contrast waste yarn.

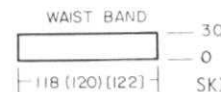
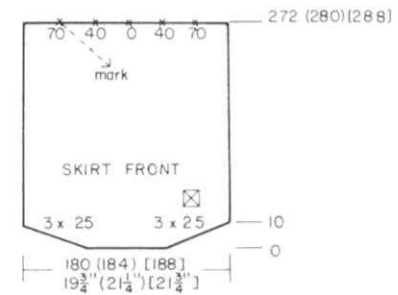

**SKIRT WAISTBAND FOR FRONT:**

Bring 118 (120) [122] needles into working position. With wrong side facing you, hang the front skirt onto these needles in the following manner; ON THE OUTSIDE OF THE MARKED STS. on waist, pick up 6 sts. fold to the INSIDE making doubled sts. on the next 6 needles. Do this for each pleat, then IN BETWEEN, decrease 7 (8) [9] sts. ON EACH SIDE. With Tension 5, knit 30 rows stockinette st. Hang the hem and bind off.

**BAND FOR LOWER EDGE OF SKIRT FRONT:**

Work the same as you did for the back lower edge.

**BANDS: General Instructions**

All bands are made with the same method. Garment Tension. CAST on the number of sts. (see chart). PART BUTTON HEM method. (Bring every other needle into D position, push in both Part Buttons and knit 1 row. Drop Cast on comb, and release Part Buttons). Knit for 24 rows. (Waistband has 30). Hang the loops on cast on comb onto alternate needle from first row. Hang the garment sts. (purl side facing you). Knit 1 row with large tension. And bind off with latch tool method without yarn (see Instruction Manual).

All bands with points. Knit 2 rows, increase for point 1 st. every 3rd row 3x knit 2 rows and decrease 1 st. every 3rd row 3x, knit 2 rows and hang as above.

- JACKET BACK: 1 hem band
- JACKET FRONT: 2 hem bands (reverse one)
- 1 neckband
- 2 Front bands
- JACKET SLEEVE: 4 bands (reverse two)

**SHELL BACK:**

Cast on 146 (150) [154] sts. and work 30 Rows K1 P1 Ribbing with Tension 3/3. Transfer the ribber sts. to main machine and continue in Stockinette stitch. Knit to Row 158 (160) [162]. SHAPE ARMHOLE: ON EACH SIDE, bind off. 10 sts. 1x, 1 st. 12x. After Row 180 (184) [188], Set Punch Card and begin LACE PATTERN. After Row 220 (224) [228] remove onto contrast waste yarn.

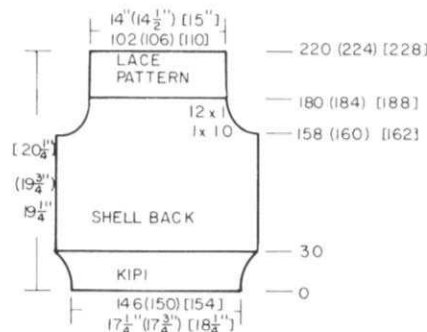

**SHELL FRONT:**

Work the front the same as the back to Row 158 (160) [162]. \*SHAPE ARMHOLE SAME AS THE BACK, BUT AT THE SAME TIME, WORK SHORT ROWS AS FOLLOWS: PUT ALL NEEDLES on the LEFT side of 0 plus 7 (5) [3] sts. on the RIGHT side of 0 into holding position. As you shape the armhole on the RIGHT side, put into holding position OPPOSITE CARRIAGE. 4 sts. 11x, (4 sts. 12x) [4 sts. 13x]. ALL NEEDLES IN WORK, knit 1 row to the LEFT SIDE. Turn Row Counter back to 158 (160) [162]. REPEAT FROM \* BUT READING RIGHT in place of left and LEFT in place of right. When short rows are completed put ALL NEEDLES IN WORK and knit 1 row to the RIGHT SIDE. BEGIN LACE PATTERN IMMEDIATELY (do not knit 2 rows first). After Row 220 (224) [228]. Remove onto contrast waste yarn.

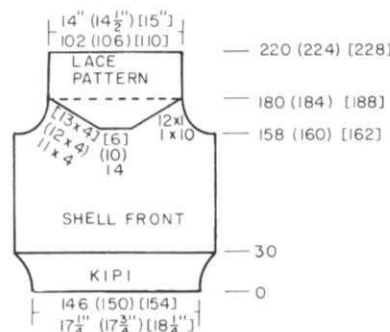



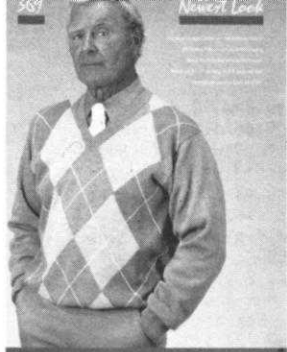

# 369

NO. 369

## MAN'S ARGYLE PULLOVER

SIZE: 38/40 (42/44)

YARN: Venetia (thin)

GRAMS:

Color A 1 Lb. 1 Lb.

Color B 3 oz. 3 oz.

TENSION: 3.1

Ribber Tension 0/0

GAUGE: 18 sts. 26 rows = 2" (5cm)

**GENERAL INSTRUCTIONS:** The Back and Sleeves are in stockinette stitch. The front is an argyle Design knitted with short rows or Intarsia. Bands are K1 P1 ribbing. Practice the argyle short row method first, see FRONT.

**FINISHING:** Weave shoulders together first, then weave sleeve decreases to armhole decreases. Hang armhole onto machine over 120 (128) needles, with purl side facing you, hang the sleeve sts. onto the same needles. Knit 1 row then bind off loosely. Work duplicate stitch to form the diamonds as shown in the picture.

### BACK:

Cast on 190 (198) sts. with Color A and work 40 rows K1 P1 ribbing. Transfer the ribber sts. to main machine and continue in stockinette stitch. Knit to Row 214 (228).

**SHAPE ARMHOLE:** ON EACH SIDE decrease 2 sts. every 3rd row 12x using the full fashion method. To work the full fashion decreases, hang sts. 3 and 4 onto needles 5 and 6 then move the sts. in to empty needles. Put emptied needles out of work. Work all 2 st. decreases this way. After row 314 (328) **SHAPE SHOULDERS:** On each side, decrease every 2nd row 2 st. 24x, 1 st. 2x (2 sts. 26x). After Row 356 (370) bind off the center 30 (34) sts. put needles on left into holding position and complete the right side first.

**\*ON NECK SIDE:** Bind off 3 sts. 1x, 2 sts. 1x, and 1 st. 1x. Bring the needles on the left into working position, knit 1 row to the left side. Turn the row counter back to 356 (370) and complete the left half. Follow the instructions from \* and don't forget to complete the shoulder shaping.

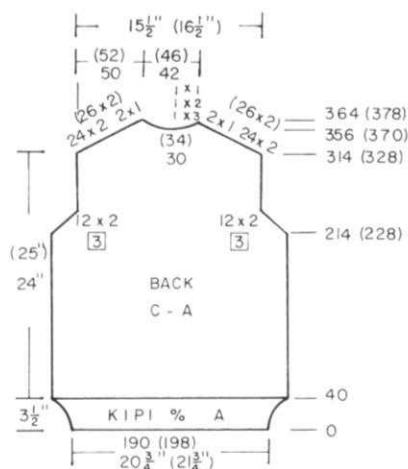

### FRONT:

Cast on 190 (198) sts. with Color A and work 40 rows K1 P1 Ribbing. Transfer the ribber sts. to main machine. Knit 2 rows stockinette stitch with Color A then begin the Argyle Design. Mark the needle bed of your machine to make it easy for you. ALWAYS work the DECREASE short rows FIRST across the row and you can use the regular short row wrap method or the Automatic Wrap method. Follow the drawing for changes in color. When you begin the INCREASE short rows, begin with 2 sts. (1 from each side). Knit in pattern to Row 214 (228). **SHAPE ARMHOLE:** same as back to Row 252 (266). Divide in the center. Put the right side first. A piece of masking tape placed lightly over the garment under the gate pegs will keep the left side from being marked while the right side is completed. **\*ON NECK SIDE,** decrease 1 st. every 4th row 21x (23x). After Row 364 (378), bind off the remaining sts. Bring the needles on the left into working position, continue in pattern and SHAPE NECK following the instructions from \*.

### FRONT

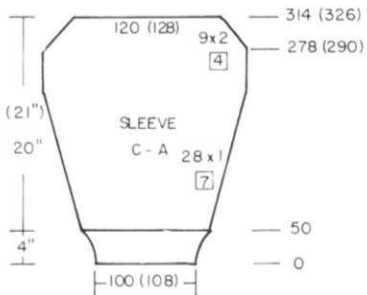
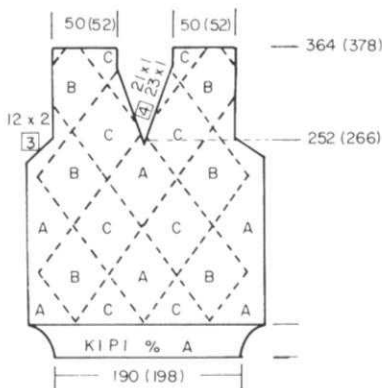

### SLEEVES: Make 2

Cast on 100 (108) with Color A and work rows K1 P1 Ribbing. Transfer the Ribber sts. to main machine and continue in stockinette stitch. ON EACH SIDE, increase 1 st. every 7th row 28x. After Row 278 (290) **SHAPE CAP:** ON EACH SIDE, decrease 2 sts. (full fashion same as back) every 4th row 9x. After Row 314 (326) bind off the remaining sts.

### NECKBANDS: 1 right and 1 left

Cast on 160 (168) sts. with Color A and work in K1 P1 Rib, increasing on the Left side 1 st. every 2nd row 8x. Remove sts. onto contrast waste yarn. Cast on 104 (108) sts. with Color A and work K1 P1 Rib, increasing on the Right side 1 st. every 2nd row 8x. Remove on waste yarn. Weave band to neckline.

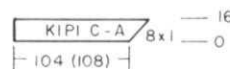





**BACK:**

Cast on 122 sts. K1 P1, Tension 5/5 for 28 rows. Transfer stitches from ribber to main bed. Knit to Row 114. Decrease on both sides 2 sts. 1x, then 1 st. every other row 41x. Take off remaining stitches on contrast yarn.

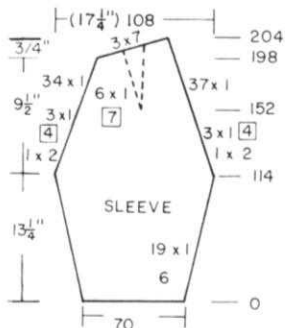

**SLEEVES:**

Cast on 70 sts. with contrast yarn. Knit 11 rows. Knit 1 row L-R with Ravel cord. Change to garment yarn. Knit 2 rows. Increase on EACH SIDE 1 st. every 6th row 19x. At Row 114, decrease ON EACH SIDE 2 sts. 1x, 1 st. every 4th row 3x, 1 st. every other row 34x on right side and 1 st. every other row 37x on left side. At the same time, starting on Row 152, move sts. on Left of 0 over 1 st. to the right. (2 sts. on 1 needles) MARK THIS NEEDLE. Every 7th row move all sts. on left of marked needle to the right 6x. At Row 198 start short rowing 7 sts. 3x (see chart), while continuing decreasing 1 st. every other row on the right 3x. Take 21 sts. off onto waste yarn.

Reverse shaping for other sleeve.

**SLEEVE BANDS: Make 2.**

Cast on 46 sts. Tension 5/5 and work 28 Rows K1, P1 Ribbing. Transfer the Ribber sts. to main machine then hang the open sts. of sleeve edge onto these needles, decreasing evenly across. Knit 1 row then bind off.

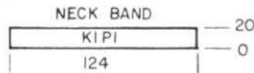
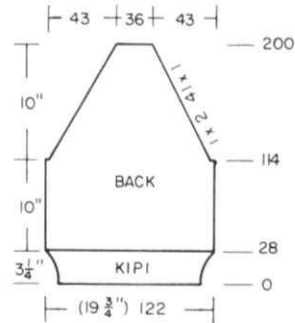

NECKBAND: Make 1

For Neckband, cast on 124 sts., K1 P1, Tension 5/5 and follow chart to Row 20. Transfer Ribber sts. to main machine. Knit 1 row stockinette on garment tension. Sew all seams together except one of the back raglan seams. Hang garment with wrong side facing you, on top of neckband needles. Bind off loosely. Fold band in half and sew in place.

**FRONT:**

Same as back to Row 114. Then decrease on each side 2 sts. 1x. Then 1 st. 39x. At row 180, bind off 20 stitches at center of neck. Put left side in holding position, finish right side first. At neck edge, decrease 3 sts. 1x, 2 sts. 2x, and 1st. 3x. Continue decreasing on armhole edge. Finish at Row 194. Reverse shaping for left side.

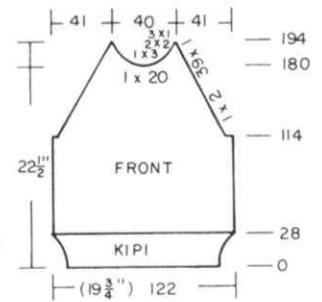

**OVERSLEEVE:**

**GENERAL INSTRUCTIONS: 910** Pattern recommended. Knit 4 rows. Remove sts. on garter bar. Move the carriage R-L without yarn and with COUNTER ON. \*Set 910 sheet to Lace Pattern A. Knit pattern A completely. Knit 8 rows stockinette. Remove sts. on garter bar. Move carriage as above. Reverse sts. Knit 3 rows. Reverse sts. again. Knit 1 row. Set 910 sheet to Lace Pattern B. Knit 4 rows with Pattern B completely. Reverse sts. using the same method. Knit 3 rows, reverse again and knit 3 rows.\* Repeat from \* to \* 1x. At row 118 take off onto waste yarn.

**OVERSLEEVE:**

**KNITTING INSTRUCTIONS:** Cast on 112 sts. with latch tool cast on L-R for 1 row. Follow General Instructions for Oversleeve. After Row 4, decrease on each side 3 sts., 1x. Then decrease 1 st., every row 7x. Then 1 st. every 4th row 14x. At row 70, decrease 1 st. every other row, 24x on right side only. On left side, decrease 1 st. every other row 20x. At Row 112, bind off 7 sts. 2x., and 6 st. 1x on left. Decreases continue on right side to Row 118.

Reverse shaping for second sleeve.

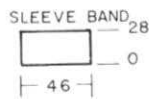
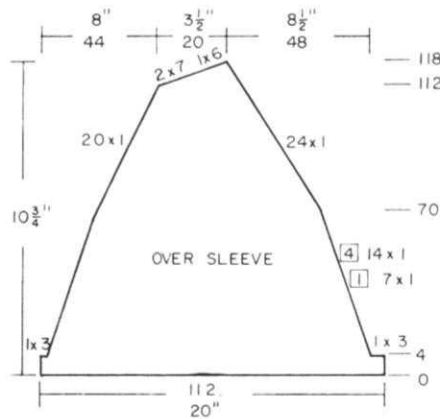

**SCARF:**

**GENERAL INSTRUCTIONS:** Lace Pattern Tension 5 - 6. Capreccio yarn. Cast on over 93 sts. (including out of work needles). Start with Orange 46 and 45 in work position, then 044, 42, 40, 38, 36, 34, 32, 30, and 28 out of work. Now 027, 26, 25, 24, 23, 22, and 21 in work position. Repeat this pattern to Green 46 and 47 in work. Pattern is between 046 and G47. Set Pattern C. SEE DIAGRAM. Cast on 93 sts. onto waste yarn and knit 13 rows. Knit 1 row L-R with Ravel cord. Now E wrap cast on from L-R with garment yarn and knit 2 rows. Now start Lace pattern and continue to Row 566 or approximately 57 inches. Bind off.

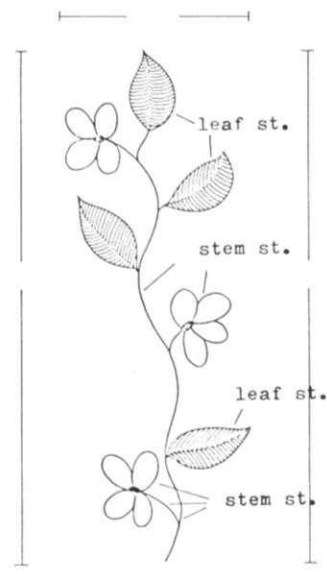
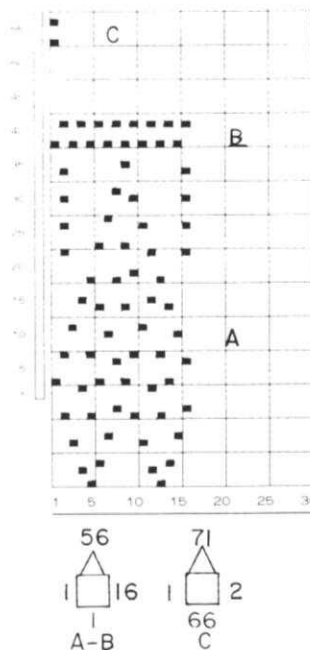
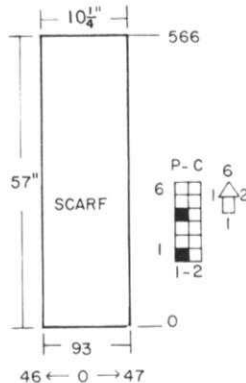



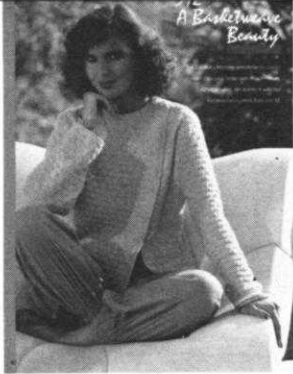

# 372

NO. 372

WOMAN'S BASKETWEAVE JACKET

SIZES: 6/8 10/12  
 YARN: Knitking Extra  
 GRAMS: color 1 650 700  
 TENSION: 2/0  
 GAUGE: 10 1/2 sts. 16 rows -  
 2" (5 cm)

2 Buttons

**GENERAL INSTRUCTIONS:**

All edges of neck, sleeves, Hem and Front are single crochet for 3 rows and 1 row of reverse single crochet.  
 Use Bulky Machine KH 230 with ribber. For larger sizes increase your Tension 1 full number per size.

**PATTERN:**

Cast on main machine, ribber down (out of work). \*Knit 3 rows. Pull up Ribber machine and set needles in pattern. 1st and last needle are on main bed for seaming. NOTE: when decreasing in pattern still end with last needles on main bed. 1 st. on main machine, 3 sts. on ribber.....across row, ending last st. on main machine. Knit 3 rows Tension 2/0. Transfer ribber sts. to main machine. Put rib needles into A position and Knit 3 rows. Move opposite needles to ribber machine (watch those end needles) and knit 3 rows and repeat from \*.

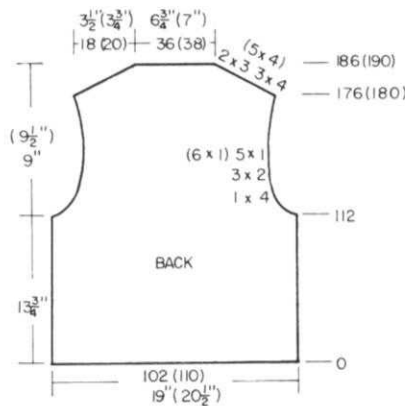

**BACK:**

Cast on 102 (110) on waste yarn, about 11 rows. 1 row ravel cord L-R. Set Counter to 0. Knit in pattern to row 112. Bind off 4 sts. on each side at underarm. Then decrease 2 sts. every other row 3x, 1 st. every other row 5x (6x). Knit straight to row 176 (180) and shape shoulders. Bind off 4 sts. each side every other row 3x then 3 sts. 2x (4 sts. every other row 5x). When necessary, transfer ribber st. to main bed to bind off. End at 186 (190).

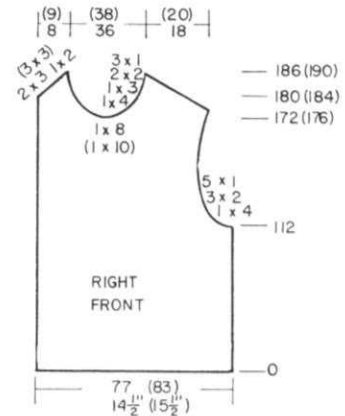

**RIGHT FRONT:**

Cast on same method 77 sts. (83). Knit to row 112. On right side Bind off 4 sts., 2 sts. 3x, 1 st. 5x (6x). At row 172 (176) put 22 (23) sts. on Left into Hold or on waste yarn. Bind off 8 (10). Now work right side of neck edge. 4 sts. 1x, 3 sts. 1x, 2 sts. 2x, and 1 st. 3x. AT THE SAME TIME AT ROW 176 (180), Bind off 4 sts. 3x, 3 sts. 2x or (4 sts. 5x). Put back 22 (23) sts. Set counter to 172 (176). Knit to row 180 (184) and shape shoulder 3 sts. 2x, 2 st. 1x or (3 sts. 3x).

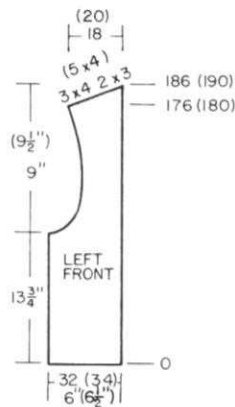

**LEFT FRONT:**

Cast on 32 (34) sts. (same as BACK). Knit to row 112. Bind off on left 4 sts. 1x, 2 sts. 3x, 1 st. 5x (6x). Knit to row 176 (180). Shape shoulder, bind off 4 sts. 3x, 3 sts. 2x or (4 sts. 5x). End row 186 (190).

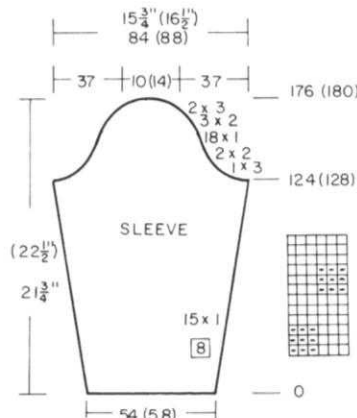

**SLEEVE:**

Cast on 54 (58) sts. Increase 1 st. every 8th row 15x. Knit to row 124 (128). Bind off on each side 3 sts. 1x, then decrease on each side 2 sts. 2x, 1 st. 18x, 2 st. 3x, and 3 st. 2x. At row 176 (180), Bind off remaining sts., 10 (14).



373

## LADIES PULLOVER WITH CROCHET COLLAR

SIZES: 6/8 (10/12)  
 YARN: Knitking Cordella and Capreccio  
 GRAMS:  
 color 1 250 300  
 color 2 20 20  
 TENSION: 6 - 7  
 GAUGE: 13 1/2 sts. 19 1/2 rows =  
 2" (5 cm)

GENERAL INSTRUCTIONS: Garment is done in Tuck and Lace combination. Purl side is the right side. Yoke are in K1 P1, Tension 3/3. Yoke collar is hand crocheted. When end sts. come to D position in Lace Pattern, push back manually.

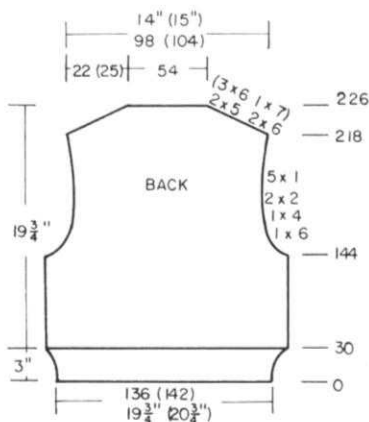

## BACK:

Cast on 136 (142) sts. Work K1 P1 in Tension 3/3 for 30 rows. Transfer Rib sts. to main machine and change to garment tension. Knit in pattern to Row 144. SHAPE ARMHOLE: ON EACH SIDE Bind off 6 sts 1x, 4 sts. 1x, 2 sts. 2x, 1 st. 5x. Continue in pattern to Row 218. SHAPE SHOULDERS: ON EACH SIDE: Bind off or short row 6 sts. every other row 2x (7 sts. 1x), 5 sts. 2x (6 sts. 3x). Bind off remaining sts. or remove on waste yarn.

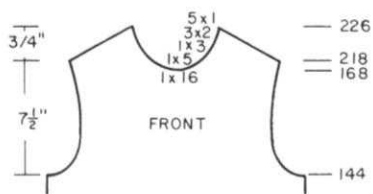

## FRONT:

Same as back to Row 168

FRONT NECK SHAPING: Bind off 16 center sts. and mark the row on the pattern card. Put the sts. on the left into "A" position with Ravel cord. Complete right side first. ON NECK EDGE bind off 5 sts. 1x, 3 sts. 1x, 2 sts. 3x, 1 st. 5x. AT THE SAME TIME shape shoulder starting on Row 218 as on BACK. TURN COUNTER BACK TO ROW 168. Set card to mark. CARD LOCK LEVER ON GO. Finish the LEFT SIDE, reversing the shaping.



## SLEEVES:

Cast on 86 sts. on waste yarn. Knit 11 rows and 1 row with Ravel cord, L-R. Change to garment yarn. Knit 2 rows. Knit in pattern to Row 38, increasing 1 st. every 4th row 8x. Continue in pattern. SHAPE SLEEVE CAP: Bind off ON EACH SIDE 3 sts. every other row 1x, 2 sts. 2x, 1 st. 2x and 1 st. every 4th row 6x. Then 1 st. every other row 10x, 2 sts. 5x 3 sts. 2x and bind off remaining sts.

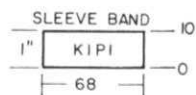

## SLEEVEBAND: Make 2

Cast on 68 sts. K1 P1, Tension 3/3. Knit 10 rows. Transfer ribber sts. to the main machine. With knit side of sleeve facing you, hang 86 sleeve sts. onto 68 sleeve band sts. (every 4th or 5th st. double). Knit 1 row and BIND OFF LOOSELY.

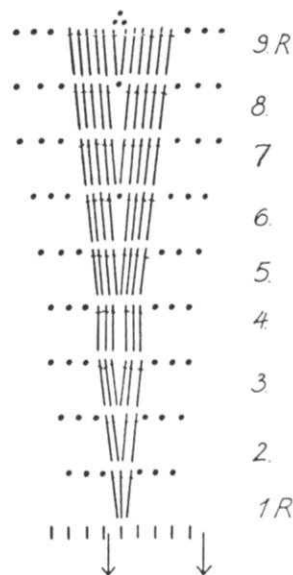

## CROCHET YOKE PATTERN

Chain 125 sts. and join to form circle. (1st rd). Then follow chart:

• = chain st.  
 † = Double Crochet

HOW TO KNIT PATTERN: Knit 2 rows. Set Card. MOVE lace carriage L-R. CARD ON GO. Move lace carriage R-L. Knit carriage on KC on the right side. And push in BOTH TUCK BUTTONS. \*Knit 4 rows. Needles are selected for Lace. Move the Lace Carriage 2x\* REPEAT BETWEEN \*.





# 374

FRONT AND BACK: Make 2

Cast on 72 (76) [80] sts. with waste yarn. Hang 1 "rag" to the right of the cast on sts. Knit 1 row with Ravel cord L-R. Change to Color 2. Set Counter to 0. Knit 16 (18) [18] rows. START INTARSIA: Mark on needle bed Color 2 stripe.....12 (14) [16]th needle from left. Color 1 stripe.....52 (54) [56]th needle from left. Remaining sts. are knitted in alternate stripes following the chart. NECK EDGE SHAPING: At Row 60 (64) [68] Bind off 2 sts. every other row 2x. Then bind off 2 sts. every 4th row 2x, and decrease 1 st. every 4th row 5x. Knit straight in pattern (follow chart) to Row 104 (111) [117]. Reverse shaping for other side of neck to Row 118 (130) [138]. Continue to follow the chart, ending at Row 208 (222) [234]. Put 64 sts. on left into holding. Take remaining 72 sts. (76) [80] off on waste yarn. Then remove 64 sts. on waste yarn (about 20 rows).

SEW ONE SHOULDER TOGETHER

NECKBAND: Color 1. Cast on 159 (167) [175], K1 P1. Knit 4 rows Tension 2/2 II, 4 row Tension 3/3 II, and 6 rows Tension 4/4 II. Transfer ribber sts. to main bed. Hang neckedge (purl side facing you) Knit 1 row at large Tension. Bind off loosely.

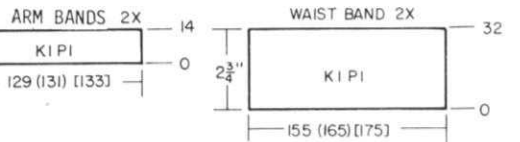
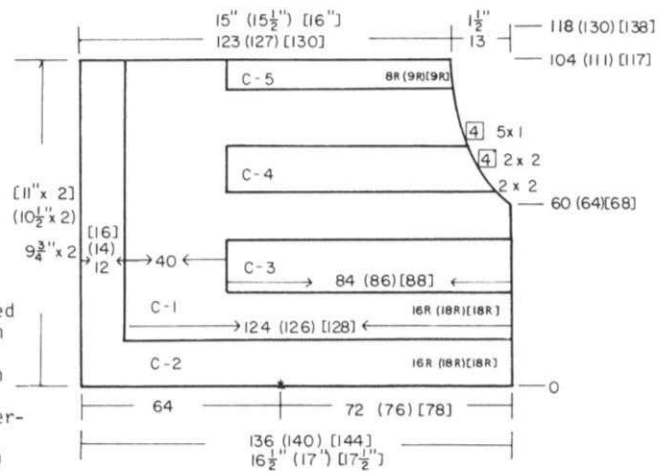

SEW SECOND SHOULDER SEAM

ARMBAND: Make 2, Color 1. Cast on 129 (131) [133], Knit 4 rows Tension 2/2, 4 rows Tension 3/3, and 6 rows Tension 4/4. Transfer ribber sts. to main machine. Hang armhole sts. for front and back onto armband sts., purl side faces you. Knit 1 row Tension 10, and bind off loosely.

WAISTBAND: Make 2, Color 1. Cast on 155 (165) [175]. K1 P1 Tension 3/3. Knit 32 rows. Transfer ribber sts. to main machine. Hang garment, as in arm and neckbands. Knit 1 row Tension 10 and Bind off loosely.

NO. 374

WOMAN'S STRIPED TOP

SIZES: 6/8 (10/12) [14/16]

YARN: Knitking Beatrice

GRAMS:

color 1	150	200	200
color 2	50	100	100
color 3	50	50	50
color 4	50	50	50
color 5	50	50	50

TENSION: 6

GAUGE: 16 sts., 21 rows - 2" (5 cm)

GENERAL INSTRUCTIONS: Back and Front are the same. It is knitted sideways, with 5 color stripes. INTARSIA METHOD. Make 2 pieces of waste knitting (rag) 64 sts. wide, about 20 rows deep.

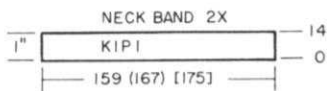

# 375

NO. 375

WOMAN'S LACE TOP

SIZES: 8/10 (12/14)

YARN: Knitking Show

GRAMS: 250 (300)

TENSION: 6 - 7

GAUGE: 12 sts. 18 1/2 rows

GENERAL INSTRUCTIONS: Bands are K1 P1 Tension 2/2 II. Lace Pattern: Punch your card. Repeat all the way. Use Lace carriage L-R. Card on G0. Move Lace carriage R-L. \*Needles are in Design Position. Every 12th needle is in work position. Push work needles back into "A" position and knit 3 rows. Bring these needles back into work position and knit 5 rows. Use Lace carriage 2x.\* Repeat \* to \* for the whole garment. When increases are on same row as lace, run lace first. Garment is knit upside down to get the lace effect. 6 Buttons.

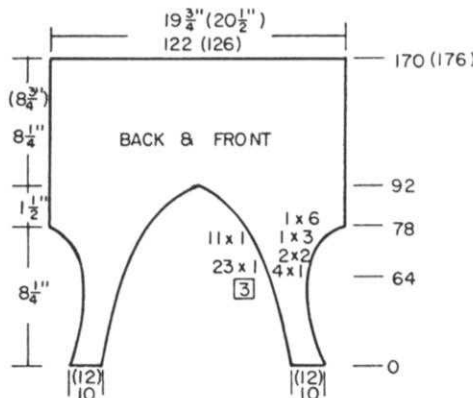

BACK AND FRONT BODICE: Make 2

Cast ON 10 (12) sts. on waste yarn, 1 row Ravel cord starting with 35th needle to the right of 0. Increase 1 st. every 3rd row 23x, and 1 st. every other row 11x, at the neck edge. After Row 64, increase at the armhole edge 1 st. every other row 4x, 2 sts. 2x, 3 sts. 1x, and 6 sts. 1x. End at Row 78. Neck edges increase continue to Row 92. At Row 92, put sts. on Ravel cord and push back into A position. Now cast on 10 (12) sts. onto waste yarn, starting with 35th needle to the left of 0. And shape neck edge and armhole as right side. At Row 92, bring right side needles into work and knit all sts. to Row 170 (176). Take off onto waste yarn.

**SLEEVES: Make 2**

Cast on 24 sts. onto waste yarn. Knit 11 rows, 1 row Ravel cord. Now cast on with Garment yarn with "E" wrap method. Knit two rows and start pattern. Follow chart for increases. Increase with "E" wrap. Watch end sts. Move weights on edges as the sleeve becomes larger. Note General Instructions. Use Lacer first on rows where lace and increase occur at the same time. At Row 66 there should be 108 sts. on machine. Continue in pattern decreasing 1 st. every 8th row 13x. Knit to Row 184 (190). Take off onto waste yarn.

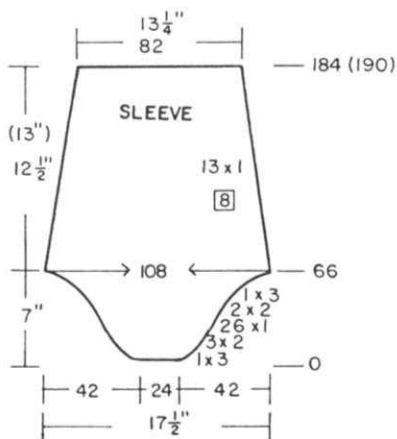

**SLEEVE CUFF: Make 2**

Cast on 65 sts. in K1 P1 Rib and knit 36 rows at Tension 2/2. Transfer ribber sts. to main bed. Hang 82 sleeve sts. onto 65 band sts. evenly across the row, purl side facing you. Knit one row large tension and bind off loosely.

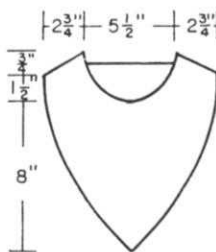
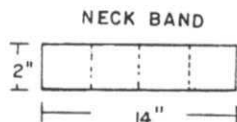
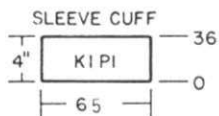

**YOKE:**

Follow our diagram or any crochet medallion pattern that measures 3 1/4 in. per medallion. Connect medallions loosely. Yoke collar is 4(1/2 motifs) in a row (see chart). Seam one shoulder together and sew collar on. Second shoulder and neck have buttons and buttonholes.

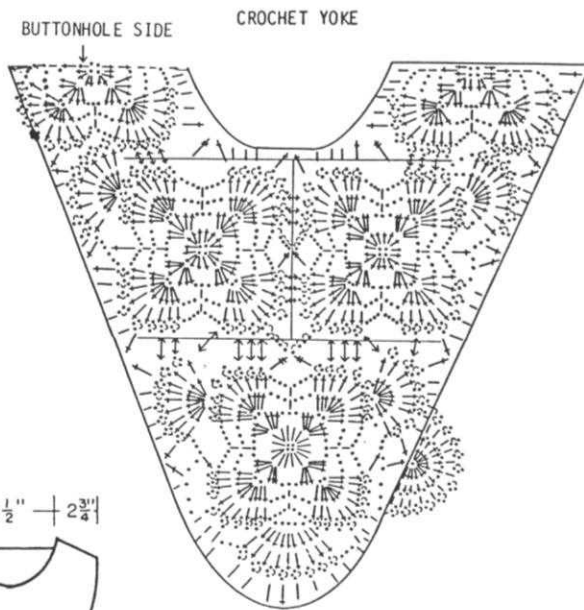

**CROCHET SYMBOL**

- = 1 chain
- | = 1 single crochet
- | = 1 half double cr.
- † = 1 double cr.
- c = 1 slip st.
- ‡ = 1 triple cr.
- C = 1 Picot = 3 chain, 1 st in 1st st. of chain. Chain 3.
- ⇕ = Connect picot to picot with half double cr.

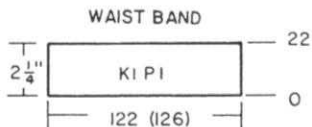
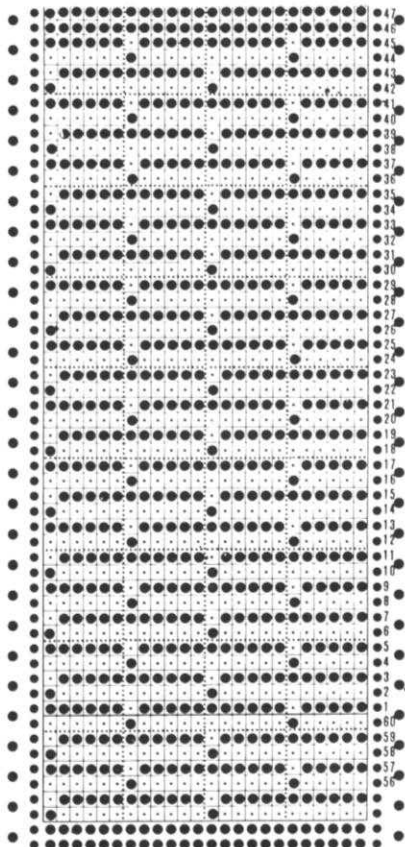

**WAISTBAND:**

Cast on K1 P1 Tension 2/2 II 122 (126) sts. Knit 22 rows. Transfer ribber sts. to main bed. Hang garment edge sts. onto waistband sts., purl side facing you. Knit 1 row large tension and bind off loosely.

**IT'S READY NOW!**

**KNITTING MAGAZINE  
BOUND VOLUME NO. 17**

- HARD BOARD COVER
- APPROXIMATELY 180 PATTERNS
- COMPLETE INSTRUCTIONS

**PRICE \$22.95**  
Shipping Costs \$3.23

Order direct from  
**KNITTING, 1128 Crenshaw Blvd.**  
Los Angeles, Calif. 90019





# 376

**BACK:**

Cast on 117 (123) sts. K1 P1 Rib at Tension 3/3 II for 28 rows. Transfer ribber sts. to main machine. Change to garment tension and Color 3. Start dogs feet on fifth row after ribbing. Knit Intarsia method, following pattern to Row 146 (154). Mark for armhole. Knit to Row 206 (222). Divide for neck, putting left side on hold or on waste yarn. Bind off center 17 sts. and finish right side decreasing 3 sts. 2x, 2 sts. 2x (every other row). Put remaining 40 (43) sts. on waste yarn. Turn counter back to Row 206 (222), and finish left side.

**FRONT:**

Same as back to Row 188 (200). NOTE: Dogs foot starts on 1st row after rib. Divide for neck, putting left side on hold or waste yarn. Bind off 15 sts. center front, then decrease 3 st. every other row 1x, 2 sts. every other row 2x, 1 st. every other row 2x, then 2 sts.

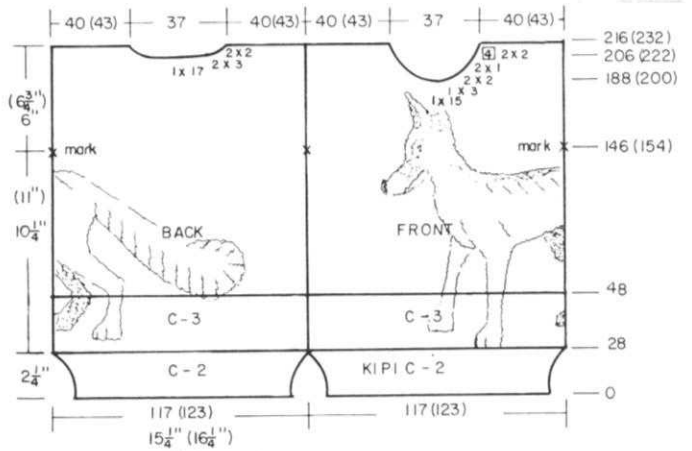

every 4th row 2x. End at Row 216 (232). Put remaining 40 (43) sts. on waste yarn. Turn counter back to Row 188 (200). Pick up left side sts. and finish, reversing the neck shaping.

**SLEEVES:**

Cast on 89 (95) sts., Color 2, in K1 P1 Rib and knit 14 rows. Transfer to main bed. Change to garment tension and knit in Color 3 to Row 46 (56). Take sts. off onto waste yarn. Make 2.

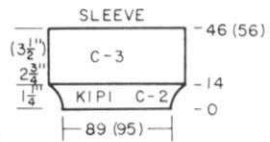

PUT ONE SHOULDER SEAM TOGETHER

**NECKBAND:**

Cast on 126 sts. in K1 P1, Color 2 Rib, Tension 3/3. Knit 12 rows. Transfer all ribber sts. to main bed and hang the neckline sts., purl side facing you, on top of band sts. Knit 1 row and bind off loosely.

SEW OTHER SHOULDER TOGETHER, SET IN SLEEVE AND FINISH SIDE SEAMS.

Color 1 □ = 1 st.  
Color 4 □ = 1 st.  
Color 5 ● = 1 st.  
Black X = 1 st.

NO. 376

BOY'S PULLOVER

SIZES: 9/10 (11/12)  
YARN: Knitking Cordella

GRAMS:  
color 1 100 150  
color 2 50 50  
color 3 100 100  
color 4 50 50  
color 5 50 50

small amount of black yarn  
TENSION: 5 - 6 (make swatch with Intarsia Carriage)  
GAUGE: 15 sts. 23 rows = 2" (5 cm)

GENERAL INSTRUCTIONS: Intarsia method. K1 P1 Rib at Tension 3/3 II. Follow the chart or send 50¢ for enlarged chart to Knitking Co

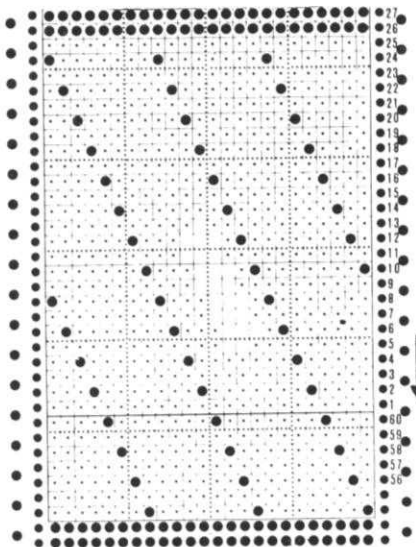
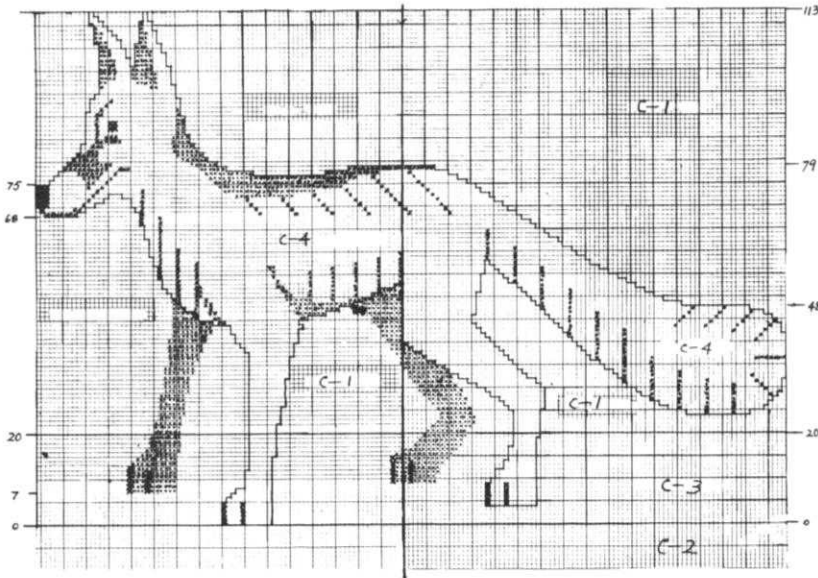

No. 1

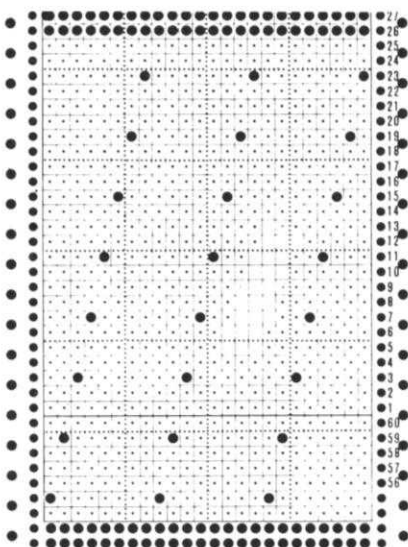

No. 2

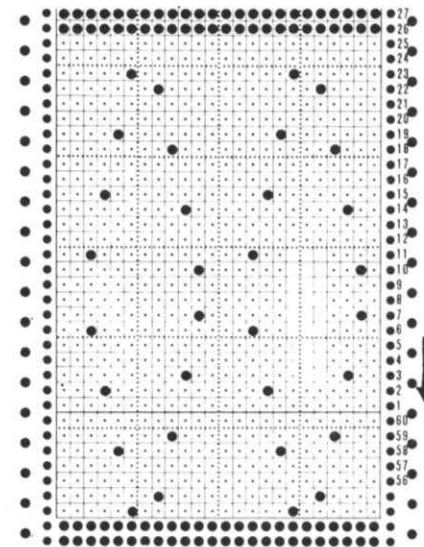

No. 3







# 378

NO. 378

WOMAN'S STRIPED TOP

SIZES: Small and Medium  
 YARN: Knitking Viola  
 GRAMS:

color 1 100  
 color 2 50  
 color 3 50  
 color 4 50  
 color 5 50  
 color 6 50 white

TENSION: 9 - 10  
 GAUGE: 11 sts. 18 1/2 rows =  
 2" (5 cm)

Band is K1 P1 Tension 7/6 II

GENERAL INSTRUCTIONS: BEFORE MAKING GARMENT, knit 6 pieces of waste material; 2 pieces 16 sts. wide, 4 pieces 32 sts. wide in the following manner: Knit 23 rows of primary color, 1 row of contrast color, 4 rows of primary color and bind off. These "rags" are helpful when casting on a large number of extra sts. NOTE: Short row method at waistline allows more stretch. Neckline and armhole has a single crochet finish in color of your choice. ATTENTION ADVANCED KNITTERS: Use your garter bar and reverse the work before and after every 2 rows of white. See Diagram. Sew pieces together by method of your choice.



WAISTBAND: Make 2

Cast on 104 sts., Color 1. K1 P1, Tension 7/6 II. Knit 32 rows, transfer ribber sts. to main bed. Hang front on top of sts. on main bed, wrong side facing you. Bind off loosely.

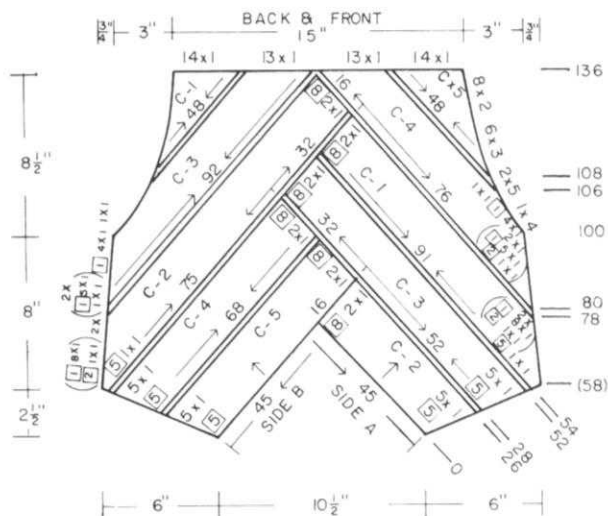

SIDE A: Make 1, reverse 1

Starting at Neck Edge, cast on 45 sts. onto waste yarn. Knit 11 rows, 1 row Ravel cord and start with open cast on garment yarn, Color 2. Tension 10 for Medium. Knit 4 rows and Reverse either on Garter Bar or by taking off on waste yarn and rehang. FOLLOWING THE CHART: Increase 1 st. every 8th row on the Left 2x, and on the Right side 1 st. every 5th row 5x.  
 Row 26, hang a 32 st. "rag" on the left (use contrast color row). Turn off counter. Knit 1 row Ravel cord over the 32 sts. Carriage on right, change to white yarn. Turn On Counter. Knit two rows.  
 Row 28, change to color 3. Knit to Row 52, increasing on Left 1 st. every 8th row 2x, and on Right 1 st. every 5th row 5x.  
 Row 52, change to white and knit 2 rows.  
 Row 54, change to color 1 (91 sts.) increase on Left 1 st. every 8th row 2x, and 1 st. every 5th row 1x on the Right. THEN at Row 58 start DECREASING ON THE RIGHT. Decrease (1 st. every other row 1x, 1 st. every row 8x) 2x.  
 Row 78, hang 16 st. "rag" on the left. Turn off counter, knit 1 row with Ravel cord over the 16 sts. Turn counter on. Pick up white and knit two rows over 76 sts. Change to Color 4.  
 Row 80, decrease using short row method, on Left, 1 st. every other row 13x, and on the right (1 st. every other row 1x and 1 st. every row 5x) 2x. Then 1 st. every row 4x and 1 st. every other row 1x.  
 Row 100, continuing decrease on the left. On the right, bind off 4 sts. 1x, then 5 sts. 2x.  
 Row 106, change to white and knit two rows on 48 sts. Change to Color 5.  
 Row 108, decrease using short row method, on the Left 1 st. every other row 14x, and on the right bind off 3 sts. 6x, and 2 sts. 8x.

SIDE B: Make 1, reverse 1

Starting at the neck edge, cast on waste yarn (as in Side A) 61 sts. Knit 4 rows and reverse as on Side A in Color 5. FOLLOW THE CHART: On the LEFT, increase 1 st. every 5th row 5x and ON THE RIGHT, increase 1 st. every 8th row 2x.  
 Row 26, change to white and knit 2 rows.  
 Row 28, change to Color 4. On the LEFT continue increasing 1 st. every 5th row 5x. On the RIGHT increase 1 st. every 8th row 2x.  
 Row 52, hang 32 sts. "rag" on the RIGHT side (same method as Side A) and Knit 2 rows in white over 107 sts.  
 Row 54, change to Color 2. On the LEFT increase 1 st. every 5th row 1x, THEN DECREASE (1 st. every other row 1x, 1 st. every row 8x) 2x. On the RIGHT increase 1 st. every 8th row 2x.  
 Row 78, knit 2 rows white.  
 Row 80, change to Color 3. Knit over 92 sts. On the LEFT decrease (1 st. every other row 1x and 1 st. every row 5x) 2x. Then 1 st. every row 4x, and 1 st. every other row 1x. On the RIGHT, short row 1 st. every other row 13x.  
 Row 100, on the LEFT, BIND OFF 4 sts. 1x, and 5 sts. 2x.  
 Row 106, knit 2 rows in white. 48 sts. on needles.  
 Row 108, change to Color 1. On the LEFT, BIND OFF 3 sts., 6x, and 2 sts. 8x. On the RIGHT, short row 1 st., every other row 14x.  
 Sew 4 pieces together, then make waistband.

# Knitting News

## PRACTICAL KNITTING HINTS

We have many requests from owners of electronic computer machines asking for help in converting our Punch Card Patterns to Mylar Pattern Sheets. The method is simple. All you need is a Mylar pattern sheet and the special pen or pencil needed to mark it with. You will keep within the lines easier if you use the plastic stencil supplied in the tool kit of your machine.

All KNITKING Punch Cards have a repeat pattern on a base of 24 stitches wide.

1. If the design is less than 24 sts. wide, draw a line down the middle of the card you wish to convert to the 910.

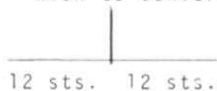

2. Look for the repeat pattern. It may be all 24 sts. or 12, 8, 6, 4, 3 or 2 sts. wide. Any width and any length.
3. It is wise to use the repeat pattern from the center portion of the card if it is 8 sts. or smaller.
4. Draw a box around the repeat, width and length. NOW transfer the holes in your box as black squares onto your Mylar 910 sheet.
5. Enter the appropriate numbers into your computer according to the Instruction Manual.
6. This works for FAIRISLE and LACE patterns and can be used for Tuck and Skip stitch. If there are many holes in a Tuck card use the following method.
7. If it is a pattern for Tuck with many more holes than blanks, follow the same procedure to #4. After you draw your box, copy the blank spaces to the Mylar sheet as black squares and put your #6 button UP. This can save you a lot of work.

These are general rules, as in all such there are exceptions. One exception is when the pattern is a combination of Lace and Tuck, where the lacer moving from right to left sets up the Tuck row. It is then necessary to copy that Tuck Row to the Mylar sheet twice, because the electronic mechanism is set by KC and the Lacer.

## SHORT ROWS WITH KA 8200 INTARSIA CARRIAGE

Refer to Page 3 of KA 8200 Intarsia Instruction Manual, Figure 4, Position E.

Short Rows (Partial Knitting) can be done easily with Intarsia Carriage. Just bring into holding position on side opposite Carriage, the number of needles (stitches) -1 that you wish to decrease. \*Lay your yarn across the needles according to pattern. Move Intarsia Carriage in same direction as yarn. Bring into holding position the inside needle (stitch) to complete the number of stitches to be decreased (automatic wrap). Now, bring into holding position opposite side from Intarsia Carriage, the number of needles -1 and REPEAT from \* until Short Row shaping is complete. To put onto Waste Yarn, bring all needles into holding except the needles to be knitted on waste yarn. These are put into 'D' position with latches open. Lay waste yarn across the 'D' position needles before moving Intarsia Carriage for 10 to 12 rows. Take off.

## FINISHING

General Finishing Instructions are always in each issue of KNITKING MAGAZINE. Refer to GENERAL INSTRUCTION PAGE. Here are a few more hints to help you put your garments together.

It is advisable to block all parts to size before seaming. Let dry thoroughly, then seam. Seaming can be done in many ways... sewing on the sewing machine, crocheting with a slipstitch method, hanging back on the machine with right sides together and latch tool bind off and hand weaving with right sides facing you being among the most popular. There is also a Baby Linker (See our Ads) that does a very nice job very quickly. After the garment is together, steam the seams lightly and again check your measurements.

## YARN KITS FOR GARMENTS IN THIS ISSUE

Most of the garments in this issue were knitted with yarns from the new KNITKING YARN CATALOGUE which illustrates the full range of colors available and includes actual yarn samples. If you do not already have our new catalogue, please send \$3.00. We will mail you one immediately and you will be able to choose your own colors for beautiful KNITKING MAGAZINE garments.

VENETIA, our best selling yarn is not shown in the catalogue. Colors available are: Sunshine-Yellow, Fuschia, Spring Green, Turquoise, Black, White, Copper-Camel, Lavender, Mandarin Red, Lipstick Red, Winter Blue, Brick, Purple Lilac, Silver Grey, Charcoal Grey, Taupe, Royal Blue, Olive, Navy Blue and Teal Blue.

No. 359 - Yarn: Venetia	SIZES: 6/8 (10/12) [14/16]		
	Price: \$28.48 \$35.60 \$35.60		
	Shipping: 2.25 2.25 2.25		
No. 360 - Yarn: Amore	One size - Medium		
	Price: \$23.90		
	Shipping: 1.85		
No. 361 - Yarn: Regia	SIZES: 34/36 (38/40) [42/44]		
	Price: \$28.60 \$33.00 \$35.20		
	Shipping: 1.85 1.85 1.85		
No. 362 - Yarn: Regia	SIZES: 6/8 (10/12)		
	Price: \$19.80 \$22.00		
	Shipping: 1.85 1.85		
No. 363 - Yarn: Viola	SIZES: Small Medium Large		
	Price: \$25.80 \$25.80 \$27.95		
	Shipping: 1.85 1.85 1.85		
No. 364 - Yarn: Show	SIZES: Medium Large		
	Price: \$19.60 \$19.60		
	Shipping: 1.85 1.85		
No. 366 - Yarn: Venetia	SIZES: 6/8 (10/12) [14/16]		
	Price: \$21.36 \$21.36 \$21.36		
	Shipping: 2.25 2.25 2.25		
No. 367 - Yarn: Vienna and Amore	SIZES: 6/8 (10/12) [14/16]		
	Price: \$41.96 \$44.66 \$44.66		
	Shipping: 2.25 2.25 2.25		
No. 368 - Yarn: Venetia	SIZES: 6/8 (10/12) [14/16]		
	Price: \$28.48 \$28.48 28.48		
	Shipping: 2.25 2.25 2.25		



No. 369 - Yarn: Venetia  
 SIZES: 38/40 (42/44)  
 Price: \$19.58 \$19.58  
 Shipping: 1.85 1.85

No. 370 - Yarn: Show  
 SIZES: 6/8 (10/12)  
 Price: \$19.60 \$22.05  
 Shipping: 1.85 1.85

No. 371 - Yarn: Alpaca & Capriccio  
 SIZES: 6/8  
 Price: \$39.30  
 Shipping: 2.25

No. 372 - Yarn: Extra  
 SIZES: 6/8 (10/12)  
 Price: \$28.60 \$30.80  
 Shipping: 1.85 1.85

No. 373 - Yarn: Cordella and Capriccio  
 SIZES: 6/8 (10/12)  
 Price: \$12.60 \$14.59  
 Shipping: 1.85 1.85

No. 374 - Yarn: Beatrice  
 SIZES: 6/8 (10/12) [14/16]  
 Price: \$19.95 \$25.65 \$25.65  
 Shipping: 1.85 1.85 1.85

No. 375 - Yarn: Show  
 SIZES: 8/10 (12.14)  
 Price: \$12.25 \$14.70  
 Shipping: 1.85 1.85

No. 376 - Yarn: Cordella  
 SIZES: 9/10 (11/12)  
 Price: \$13.93 \$15.92  
 Shipping: 1.85 1.85

No. 377 - Yarn: Cordella  
 SIZES: 6/8 (10/12) [14/16]  
 Price: \$ 9.95 \$11.94 \$11.94  
 Shipping: 1.85 1.85 1.85

No. 378 - Yarn: Viola  
 SIZES: Small/Medium  
 Price: \$15.05  
 Shipping: 1.85

NEW, DEMONSTRATORS AND TRADED MACHINES AT GIVE AWAY PRICES...

Nobody can beat our prices, so if you want a second machine, place your order as fast as possible... Maybe you have a friend who cannot afford a brand new machine... If so, please tell her about our low, low prices... and if you want a machine not listed below, let us know... We have too many to list them all.

S

			CONDITION	LIST PRICE	SALE PRICE
SINGLE BED	KNITKING KH 910	COMPUKNIT Electronic W/Lacemaker (Demo/New Machine Guarantee).....	Like New	\$949.95	\$699.00
	KH 881	Punch Card Knitter W/Built-in Knitleader & Lacemaker - Demo-New Mach. Guarantee....	Like New	599.95	499.95
	KH 230	BULKY - Demo - New Machine Guarantee.....	Like New	379.95	259.95
	KH 120	258 Needle Knitter - Push Button Pattern Selection - Demonstrator .....	Like New	429.95	249.95
	KR 120	258 Needle Ribbing Attachment - Demo.....	Like New	329.95	199.95
	KH 341	Folding Knitter/Built-in Knitleader & Carrying Case.....	Like New	249.95	179.95
	CN9N	JUMBO Knitter - (Trade-in).....	Very Good	299.95	95.00
	CN9	JUMBO Knitter - (Trade-in).....	Very Good	249.95	60.00
	KR 830	Ribber.....	Excellent	289.95	175.00
	KR 880	Ribber.....	Excellent	289.95	175.00

A

SINGER	SK 560	Computerized Electronic W/Lacemaker/Demo...	Like New	1249.95	849.95
	SK 500	Computerized Electronic.....	Excellent	950.00	399.00
	SK 360	Punch Card Knitter - Demonstrator.....	Like New	529.95	399.00
	SK 360	Lacemaker Carriage - Demonstrator.....	Like New	174.95	125.00
	SRP 50	Ribber - Fits 328/360/500/560.....	Like New	279.95	199.00
	FK 370	250 Needle Knitter - Demonstrator.....	Like New	569.95	459.95
	FRP370	250 Needle Ribber - Demonstrator.....	Like New	339.95	239.95
	SK 120	BULKY Knitter - Demonstrator.....	Excellent	279.95	175.00
	SR 120	BULKY Ribber - Demonstrator.....	Excellent	279.95	165.00
	MK 70	LECLE - Folding Portable -18 St.,Punch Card.....	Excellent	379.95	185.00

L

GENIE	KH 710	Push Button Pat. Sel. & Lacemaker - Demo...	Like New	289.50	199.50
	KR 710	Ribber - Demonstrator.....	Like New	269.50	189.50
	CH1800	200 Knitter/Color Changer/Pattern Master...	Excellent	199.95	95.00
BROTHER	KH 588	Push Button Pattern Selection/Lacemaker....	Excellent		125.00
	KH 587	Push Button Pattern Selection/Lacemaker....	Very Good		99.50
	KH 552	8 Button Selection - No Lacer.....	Very Good		79.50
	KH 583	8 Button Selection - No Lacer.....	Very Good		79.50

E

TOYOTA	KS 901	Punch Card Knitter W/Lacemaker .....	Like New	629.95	399.00
	K 33	Knit Tracer.....	Like New	117.95	69.95
	K 787	Punch Card W/KR 460 Ribber.....	Excellent	829.90	425.00
	KS 727	Punch Card Knitter W/KR 450 Ribber.....	Excellent	649.95	349.00
	K 31	Knit Tracer (No Chart).....	Good	109.95	39.50
STUDIO	323	Punch Card Knitter.....	Excellent	399.95	175.00
	312	Punch Card Knitter.....	Very Good	349.95	125.00
	BULKY	.....	Very Good	279.95	150.00
JUKI	1200	Punch Card Knitter with/Ribber.....	Very Good	449.95	175.00
KNITKING LINKERS	- DEMONSTRATORS - LIKE NEW.....		Like New	329.50	175.00
BABY LOCK	605	4 Thread -Cut/Sew/Overlock.....	Excellent	429.00	250.00
	606	Blindstitch - Demonstrator.....	Excellent	599.00	325.00
TRIMLOCK	524	4 thread -Cut/Sew/Overlock...Demo.....	Like New	429.00	285.00

# LINKER

AT LAST... An automatic bind off tool for KNITKING/BROTHER machines, Models KH 830 through KH 910. Simple to use and efficient in operation, the KH 8310 LINKER fits on the needle bed of the machine and as you turn the control knob, it automatically binds off your knitting. Can also be used for joining seams together, attaching collars, etc... How did you ever get by without it?

A similar tool, that operates in the same way, is available for SINGER/STUDIO machines. Order S.C. 1 for 320 to 328 Series. S.C.3 for 360 and 560. S.C. 7 for Lecte.

Price for all models: \$79.95  
Mailing costs 2.50

Order from your local dealer or direct from KNITKING 1128 Crenshaw Bl. Los Angeles CA 90019



## knitking SEMINAR & OPEN HOUSE 1984

It will run from October 8th through the 13th and will be held as usual on our premises at **1128 Crenshaw Blvd., Los Angeles, Calif. 90019.**

All experts at KNITKING will be in attendance plus many **acknowledged guest authorities**...We will repeat our very successful daily Fashion Show and Contest with daily prizes and the daily winners will be eligible for the finals and a **GRAND PRIZE** at the end of the Seminar. All types of garments and household items will be eligible. So, start preparing now. Knitting machine dealers and KNITKING employees will not be eligible for the contests.

Admission to KNITKING Seminars is **FREE**. Coffee and doughnuts are available all day every day free of charge.

Regular Seminar visitors will tell you that ours are the best...So, enter the dates in your diary now... **October 8th through the 13th** and plan to be with us.



# essentials...

Order from your local Dealer or direct from  
**KNITKING**—1128 Crenshaw Blvd.,  
 Los Angeles, California 90019

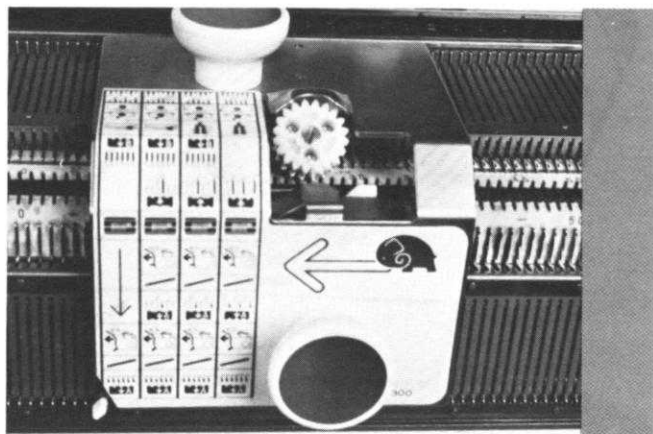

For fast and accurate transfer of stitches from Ribber to Knitter, the Automatic Transfer Carriage is ESSENTIAL.

Model 8300 is for Ribbers KR 830, KR 850 and KR 900 and machine models KH 830, KH 840, KH 860, KH 881 and KH 910. Model 7100 is for the KH 710 GENIE with KR 710 Ribber.

The PM 10 Automatic Punch Card puncher is essential for speedy punching of all your punch card designs. It's O.K. for all KNITKING, Brother, Singer, Studio and Toyota punch card machines except the Singer/Studio F-370 machine which uses the PM 70 Automatic Puncher.

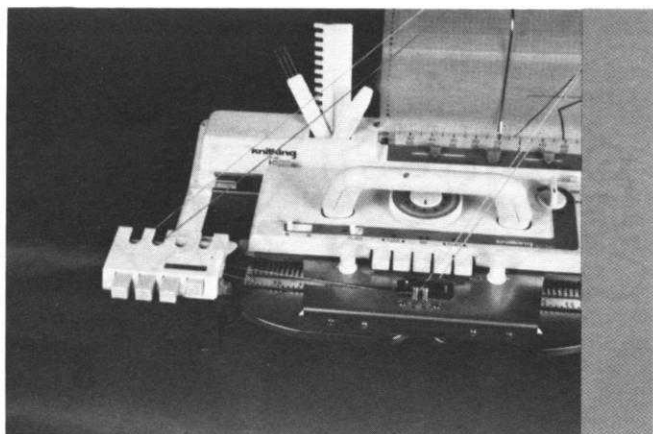
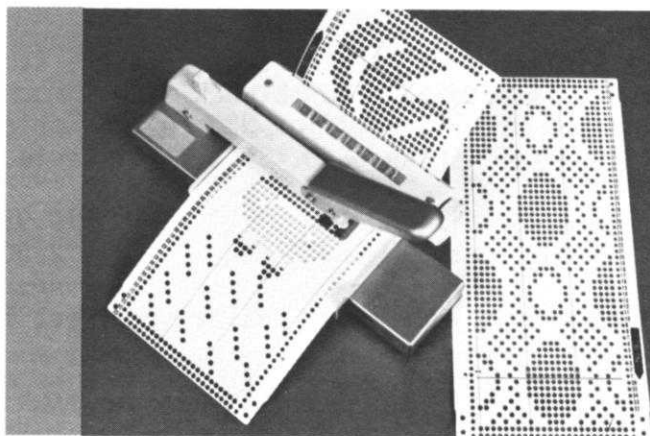

The KHC 820 Color Changer is essential for automatic changing of colors when knitting on KNITKING/BROTHER machines Models KH 820, KH 830, KH 840, KH 860, KH 881 and KH 910.

The KRC 830 Color Changer is essential for automatic color changing and the knitting of four color designs when using a Knitter and Ribber combination. It operates on Models KH 820, KH 830, KH 840, KH 860, KH 881 and KH 910 with Ribbing Attachment.

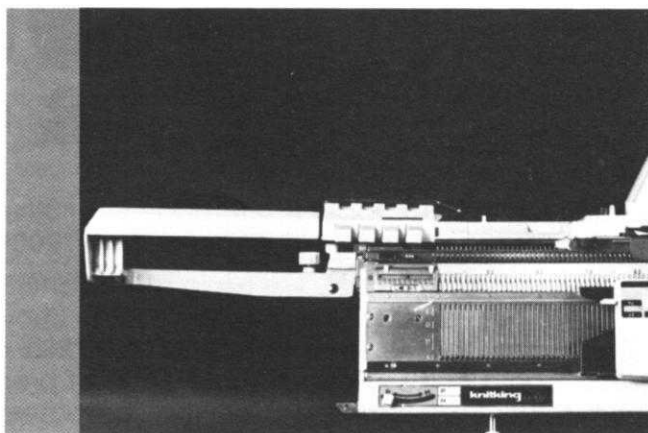



361

# Bigger, Brighter, Bolder!

Stripes in any color combination please a fashion conscious man. Knitted in Stockinette stitch with color stripes and K1, P1 Ribbing for bands. Regia is the yarn. Sizes 34 to 44.

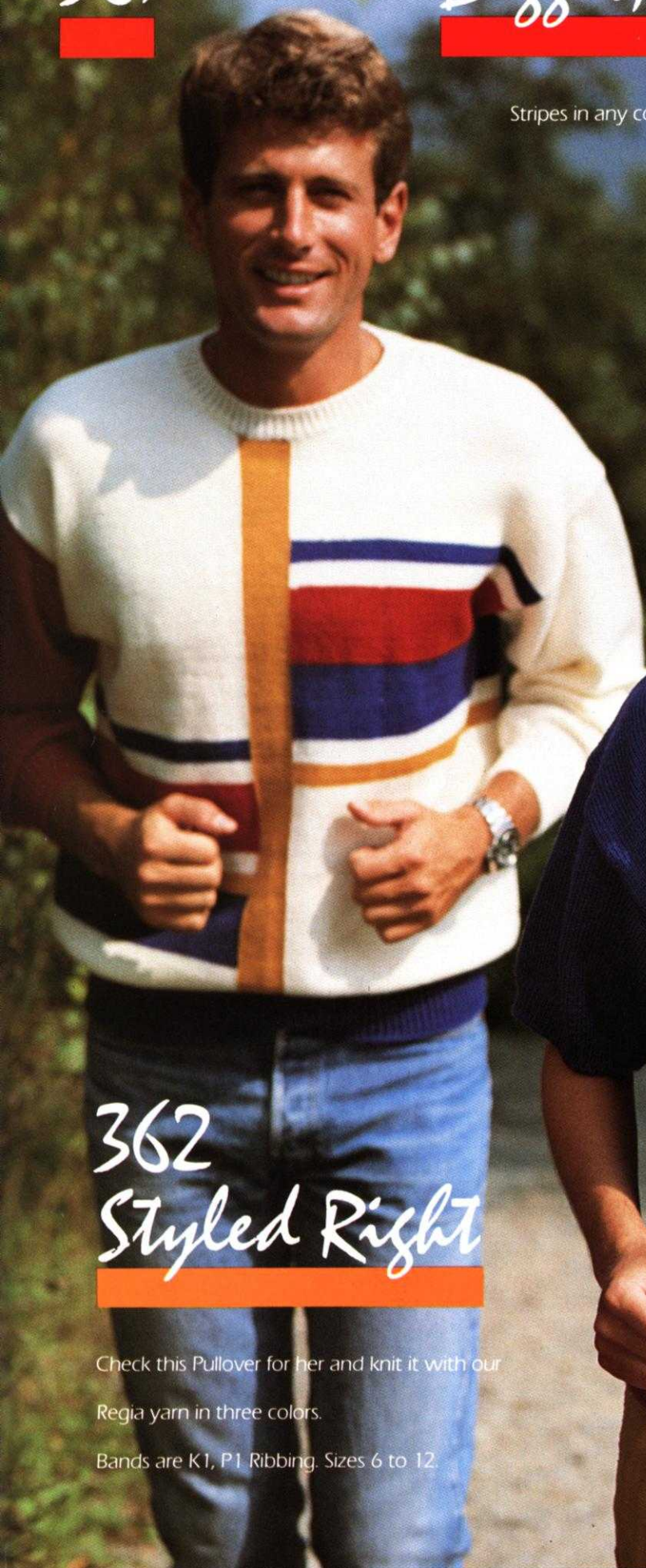

## 362 Styled Right

Check this Pullover for her and knit it with our Regia yarn in three colors. Bands are K1, P1 Ribbing. Sizes 6 to 12.





# 377 Knitting Pretty

Three Punch Cards are used to make  
this feminine and lovely Pullover.

Isolate the diagonal Lace and  
Rib the bands. Cordella yarn.

Sizes 6 to 16.

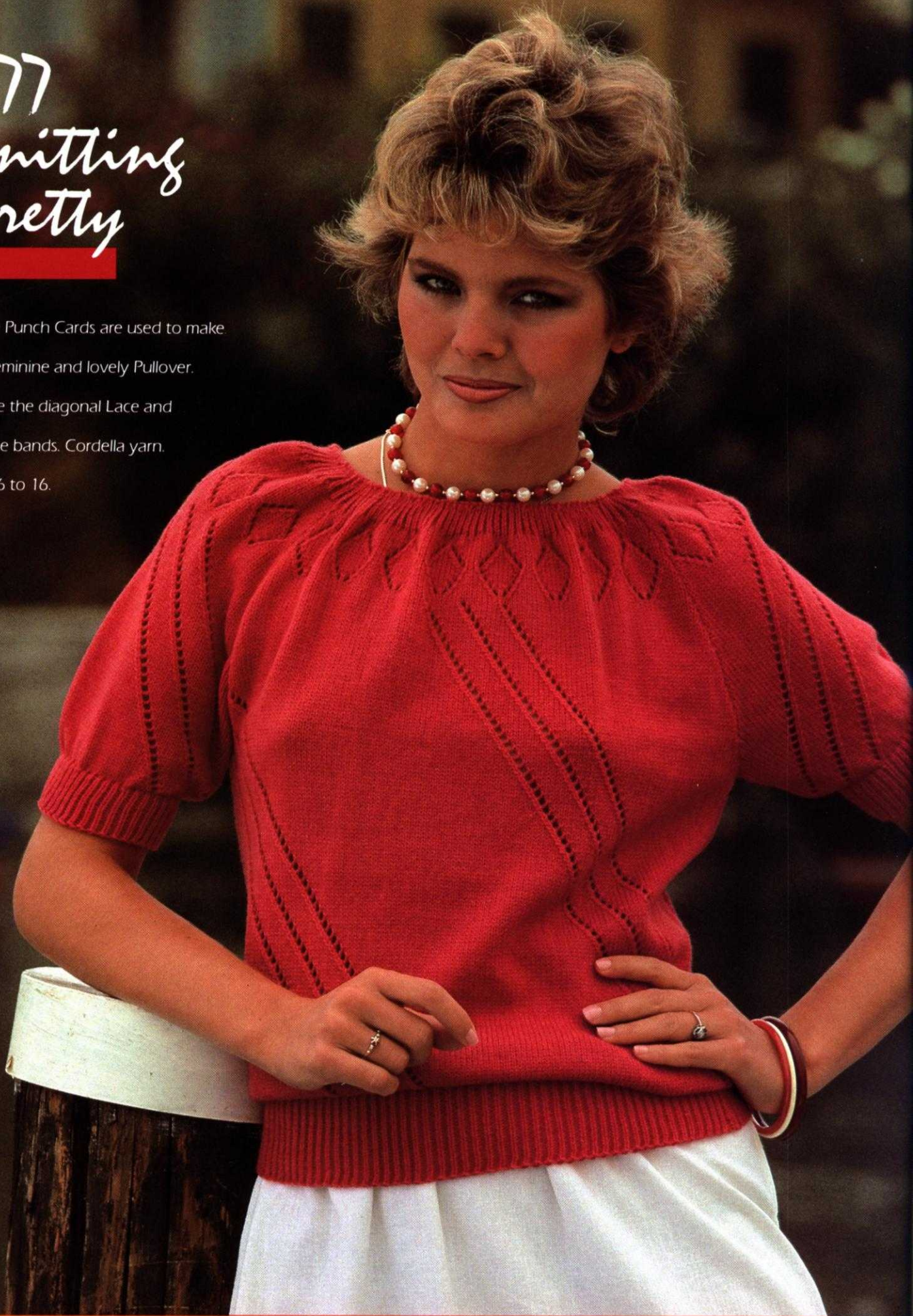



# 364 Best of Show

A Tuck stitch with Stripes is worn on the purl side. Your Man will wear it with pleasure and enjoy the soft comfort of our Show yarn. Use K1, P1 Ribbing for the bands. Sizes, Medium and Large.

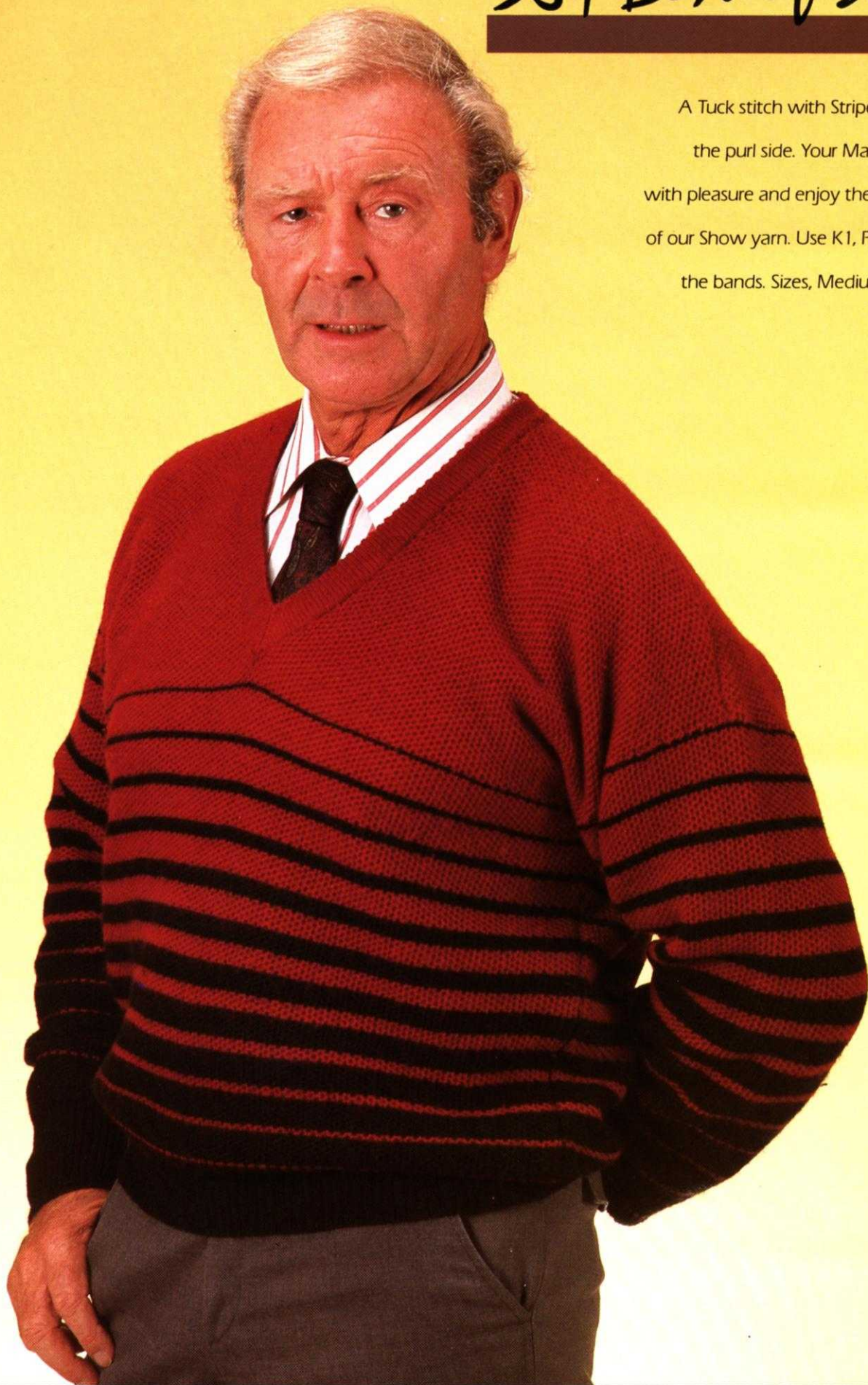





# 372 A Basketweave Beauty

The 230 Bulky Machine with Ribber is used to make this lovely Jacket with its side closure.

Crochet all bands. We knitted it with our excellent Extra yarn in Sizes 6 to 12.



# 374 Focus on Fashion

Stripe it again and again...Knit several striped Tops in any color combination, each will be beautiful.

Knitted sideways on the machine, stripes are made using Intarsia

method. Bands are K1, P1 Ribbing,

the yarn is Beatrice.

Sizes 6 to 16.





# 363

## Starring Stripes

Vary the width of stripes of this sideways knitted Pullover.

It's very easy to knit in

Stockinette stitch with K1, P1

Ribbing for the bands.

Beautiful Viola is the yarn,

the Sizes are Small,

Medium and Large.





369

## Argyle's Newest Look

The large Argyle Design on the front section of this Man's Pullover can be knitted using Short Rows or the Intarsia technique. Bands are K1, P1 Ribbing. Knit it with our fine Venetia yarn and in Sizes 38 to 44.

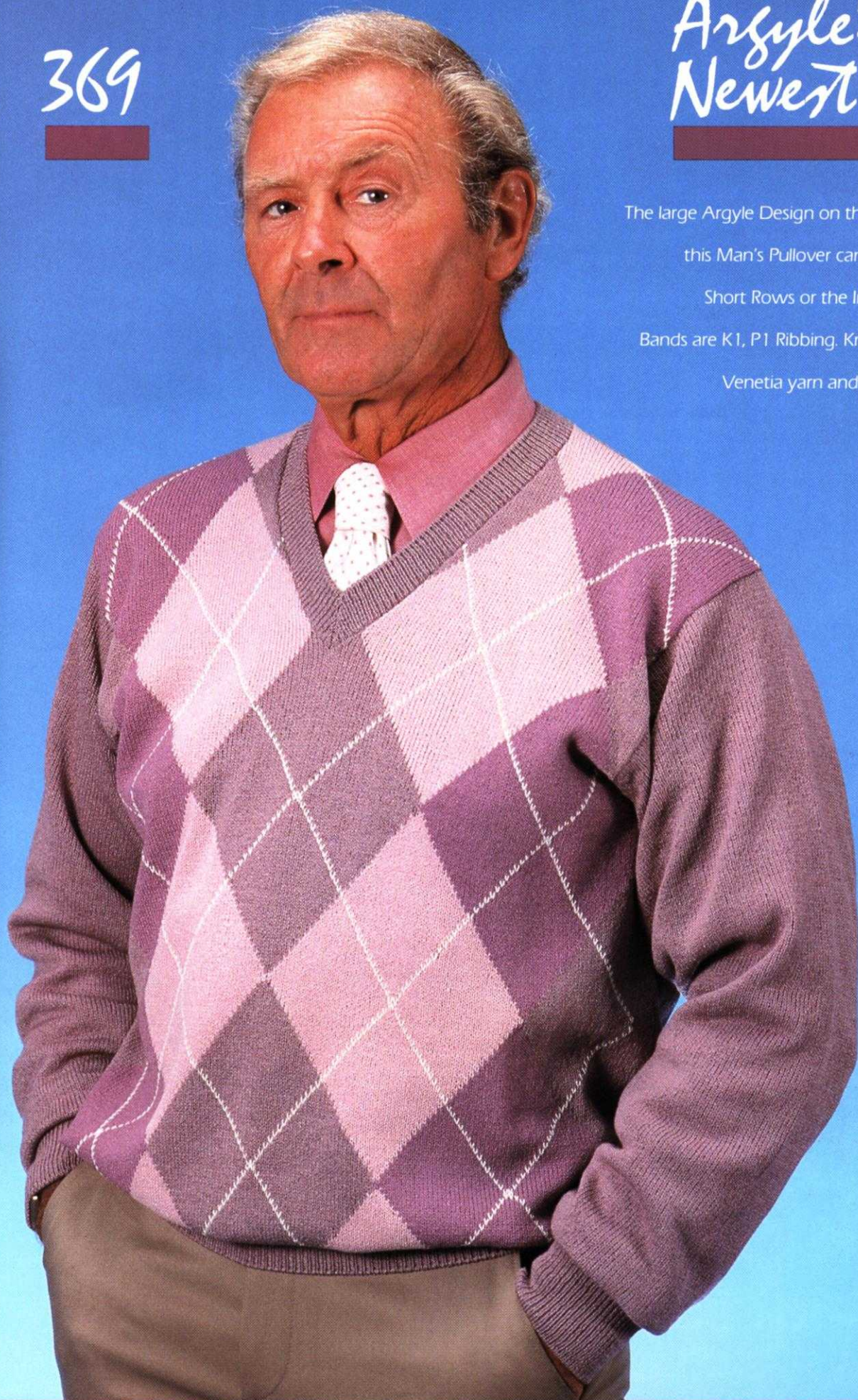



# Every Body looks better in knits. . and when you look good you fe

You do not have to be a thin model to wear knits. Wear knitted clothes in the style and fit of your choice and you will feel like a million dollars. . .

The dollar savings when you knit clothes on a knitting machine for yourself and the entire family is far greater than if you sewed them on a sewing machine.

Invest in an easy to operate versatile KNITKING automatic Knitter. . . You will be amazed at how much money you save, your friends and neighbors will envy you your outstanding collection of knits and you will experience the joy of accomplishment in knitting them yourself.

You can also knit household items; drapes, bedspreads, table covers, afghans, cushion covers, wall hangings, etc. etc.

KNITKING is a full service company. . . We publish beautiful full color bi-monthly KNITKING MAGAZINE with up to 30 complete patterns in each issue, garments for women, men and children plus household items. We manufacture and import top quality yarns and make them available to our customers at special discount prices.

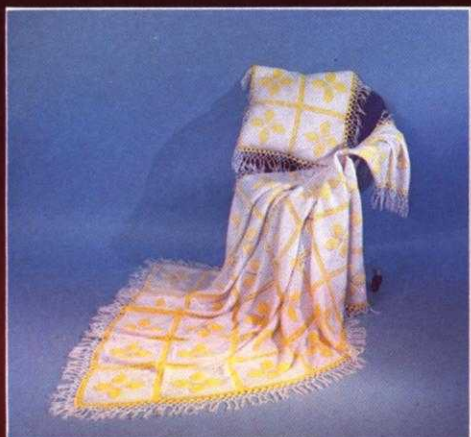

The handsome bedspread with pillow to match cost a total of \$32.00 to make.

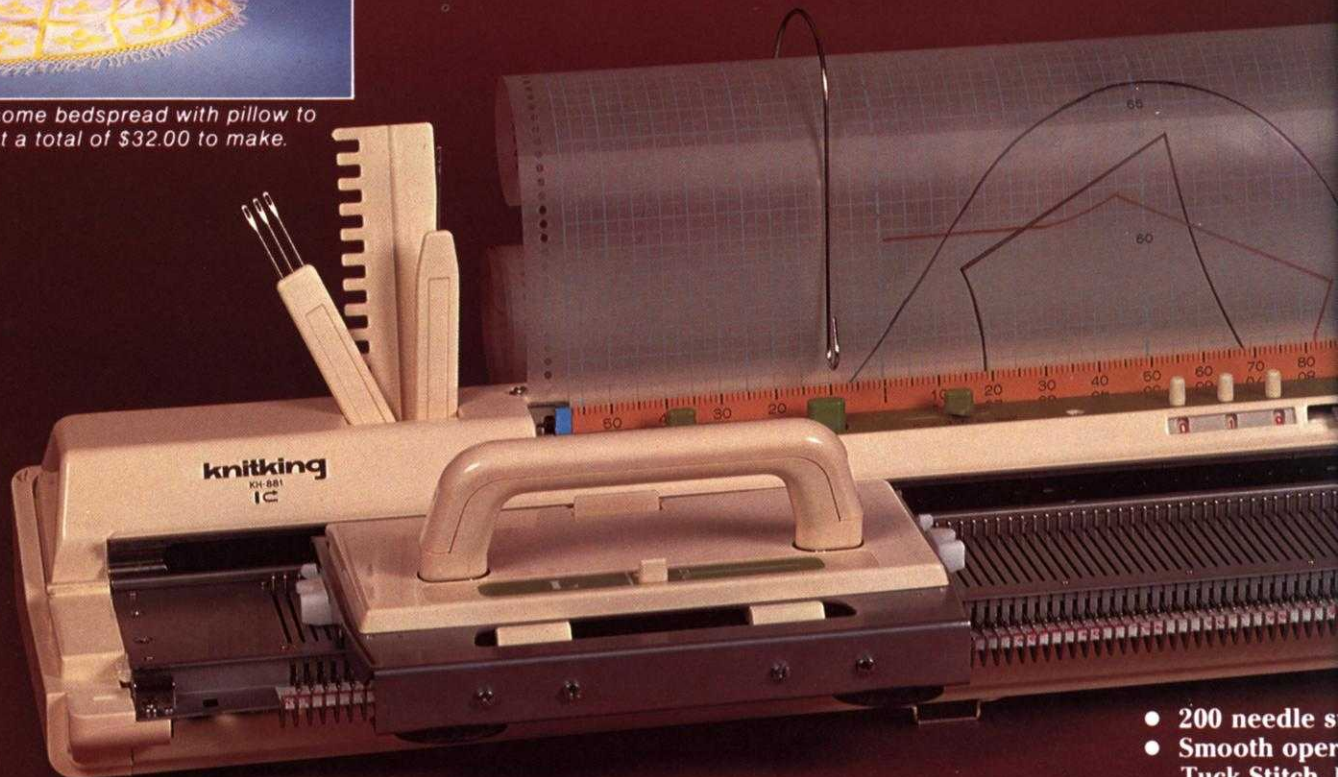

## KH 881

- 200 needle s
- Smooth oper
- Tuck Stitch, l
- Lace Carriag
- fine lace.
- 20 Pre-punch
- Stitch knittin



el good.

A stunning KNITKING MAGAZINE pullover in a programmed Fairisle Design. You can make it in any colors you choose for \$18.50.



One for you and one for the man in your life. Make them both in a few hours for less than \$20.00.



Here's a fun pullover that would sell for around \$300.00. It's an original from KNITKING MAGAZINE and cost less than \$30.00 to make. All of the fancy stitches were pre-programmed and knitted automatically.



Doesn't she look cute in her warm sweater knitted with odds and ends of left over yarn? It's a KNITKING MAGAZINE Pattern.

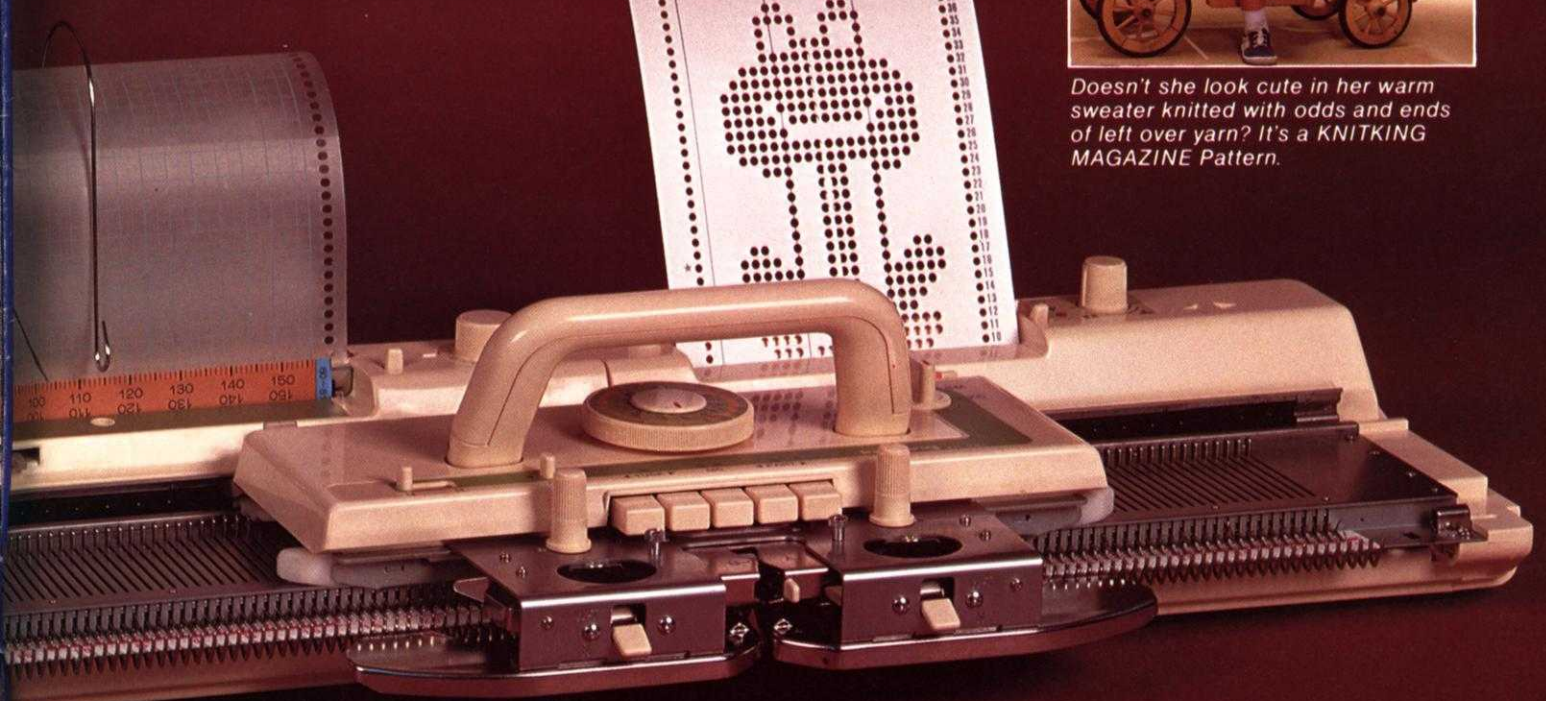
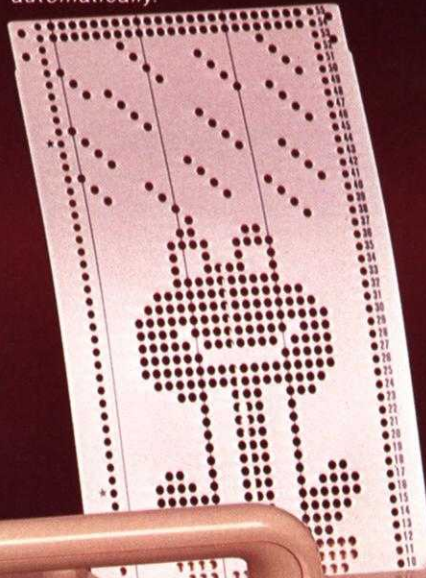

Your KNITKING KH 881 is complete with :

Stainless steel needle bed.  
 Working Main Carriage for Stockinette Stitch,  
 Fairisle, Weaving, Plating, etc.  
 For lovely lace work—both standard and  
 Pattern Cards for all types of Pattern

- Two step-by-step Instruction Manuals with over 400 illustrations.
- Complete Kit of Tools with spare Needles, special lubricating oil, cabling Tools, etc. etc.
- Built in Knitleader Charting accessory that tells you on a row by row basis when to increase and when to decrease. Simplifies the knitting of garments to accurate size.
- One year warranty on parts and service.



# 376 Motif Knitting

Intarsia seems to be the name of the game and you could insert any Motif of his choice on the front section of the Boy's Pullover.

Rib the bands and use our Cordella yarn.

Sizes 9 to 12.

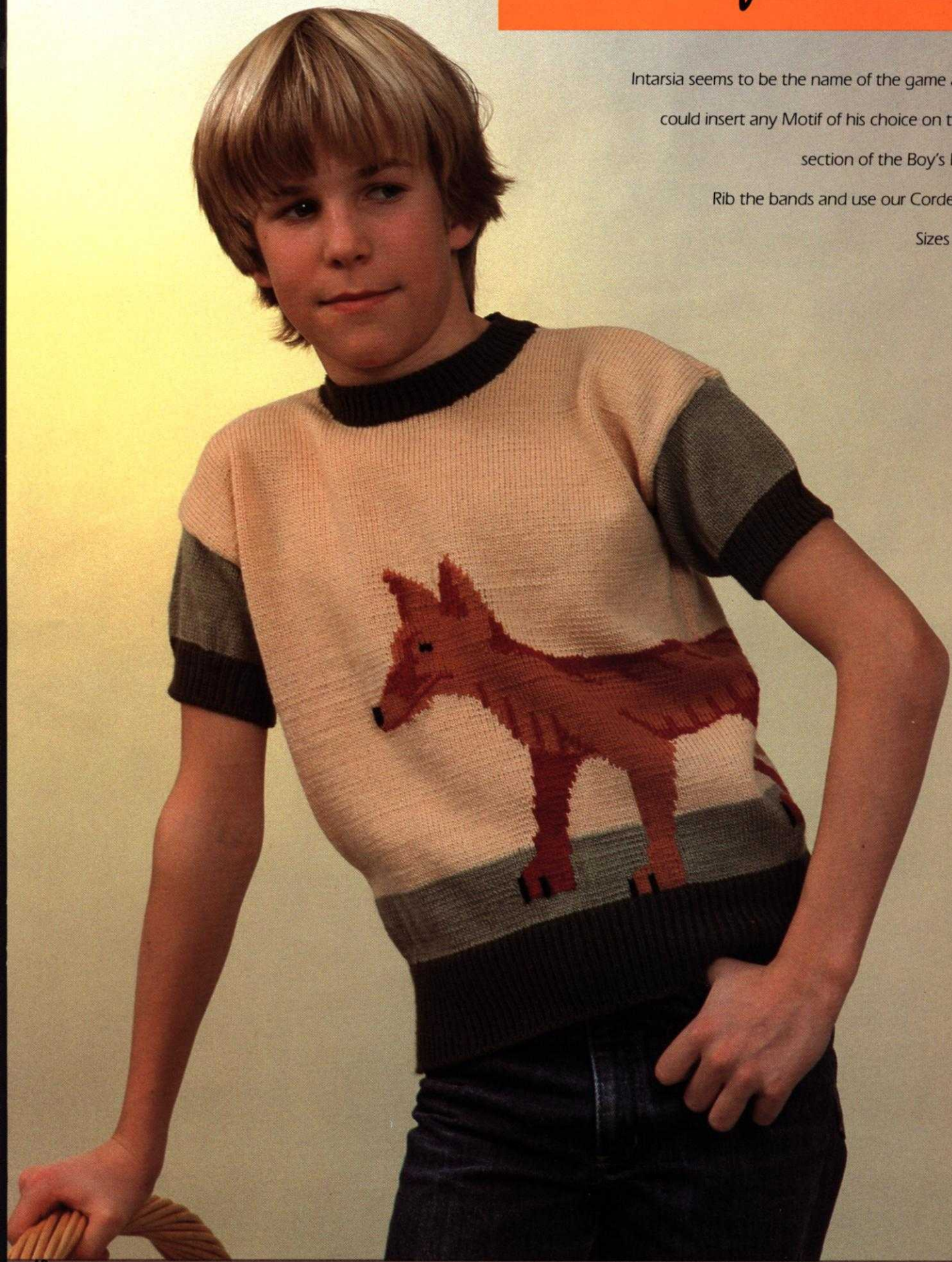



375

## Old Fashion Charm

Very feminine and very much in style is this lovely Top reminiscent of yesteryear.

It's a Lace Design knitted from the top down with Ribbed sleeve and waist bands.

Crochet the Yoke and high Collar.

Knit it with our Show yarn in

Sizes 8 to 14.





# COMPUKNIT KH 910

'the world's finest knitting machine'

- Incredibly versatile... Anything you can trace or draw is automatically reproduced in your knitting in the colors and yarns of your choice.
- Simple to program and easy to operate, the COMPUKNIT KH 910 is the 'State of the Art' in home knitting machines. It is the only knitter made that has a memory unit to retain your program if you suffer a power outage or wish to move your knitter from one place to another.
- The maximum width of motif or pattern design possible on any punch card machine is 30 stitches (the standard is 24). The COMPUKNIT has no limit. It is possible to knit a single picture or lace design over the full width (200) needles of the needle bed. It will, in fact, do everything that's possible on a punch card machine and much much more.
- If you already own a knitting machine, you must consider trading up to a fantastic COMPUKNIT 910. If you have never owned a knitter before, start at the top and save money and save all the intermediate steps.



Order from your local Dealer or direct from  
VISA and MASTERCARD accepted

## KNITTING

4128 Crenshaw Blvd.  
Los Angeles, CA 90019  
Telephone: (213) 938-2077