

knitking

magazine



DK 1046



DK 1042

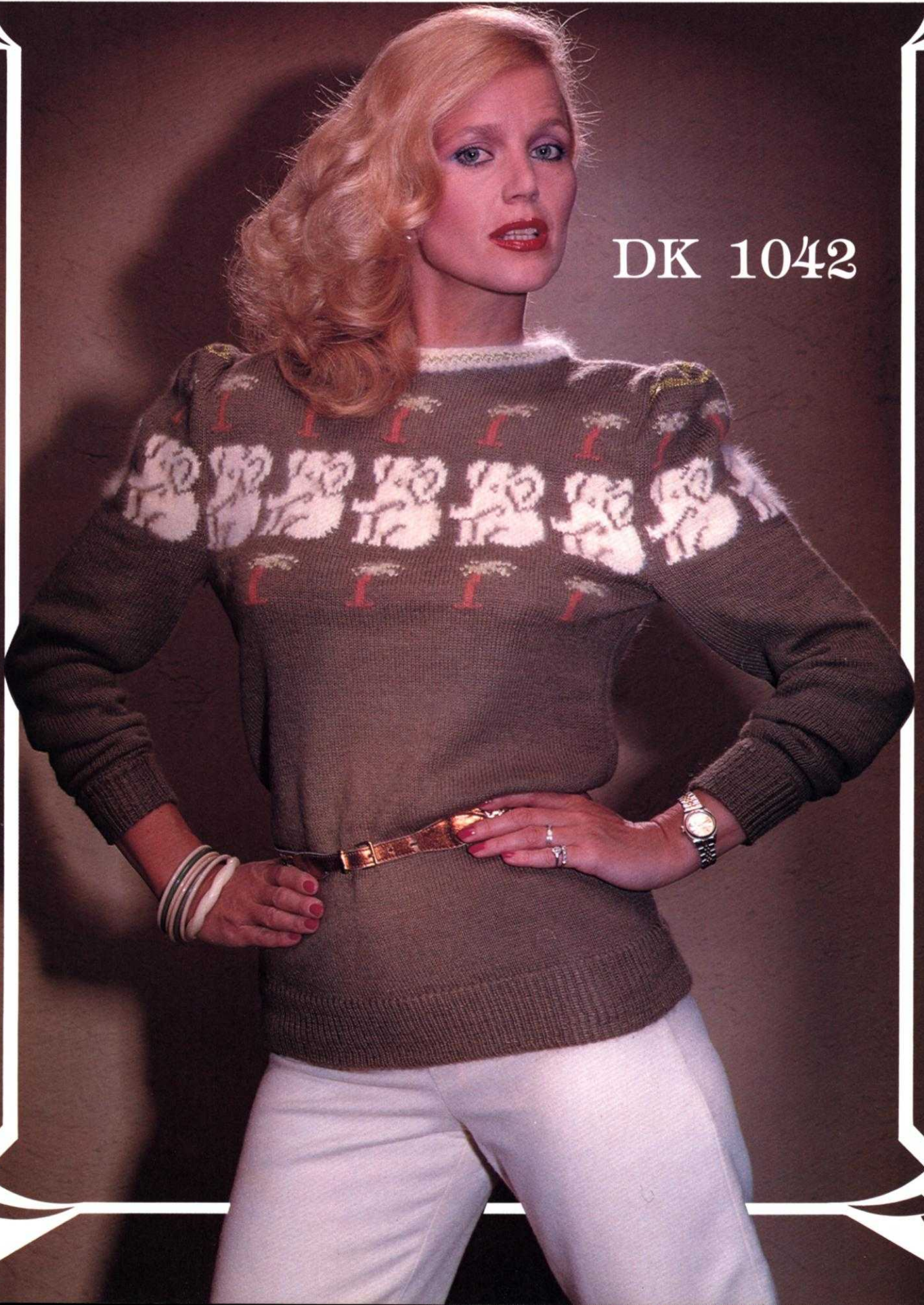

DK 1044



DK 1043



HP 1053

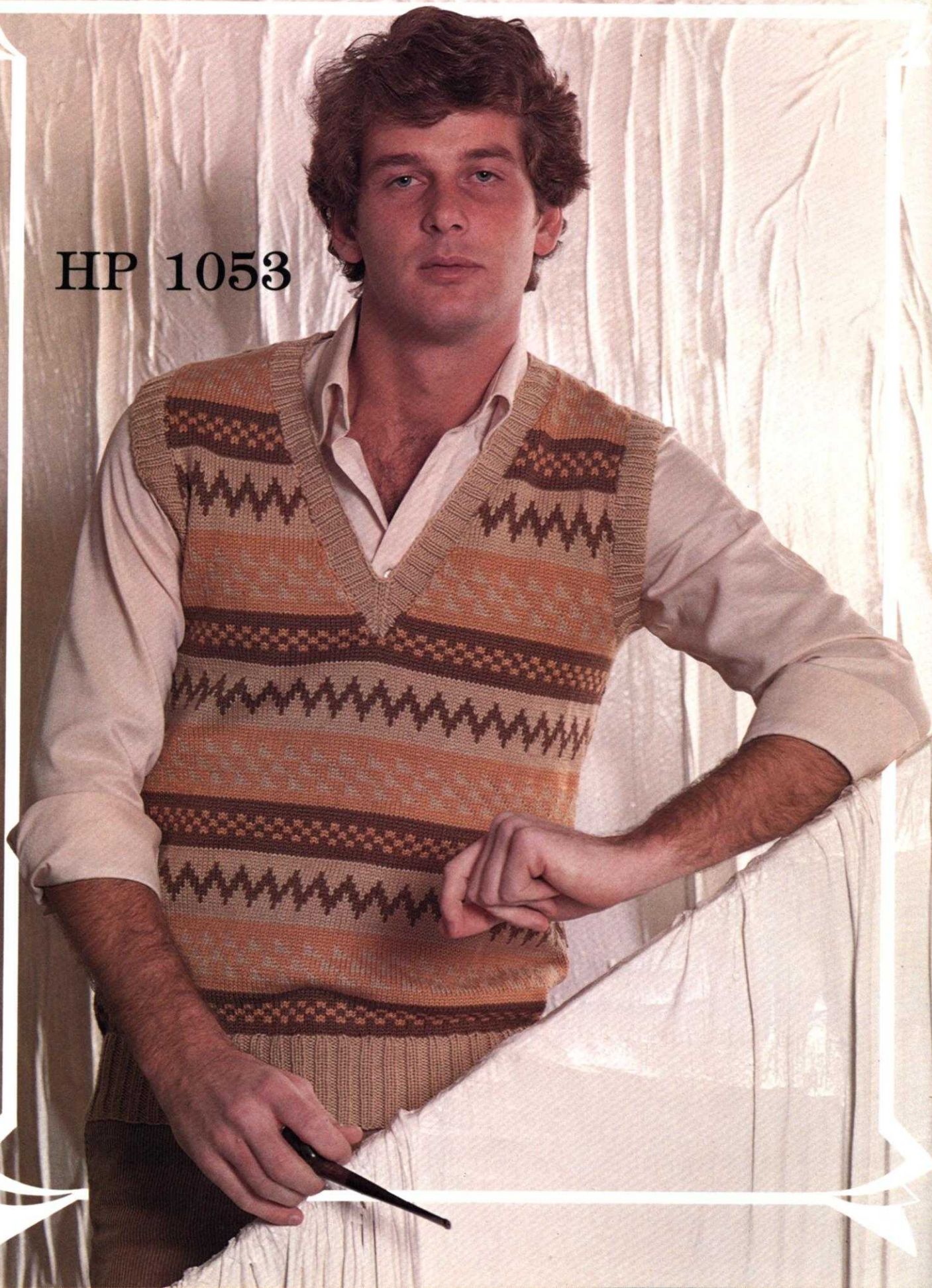

DK 1051

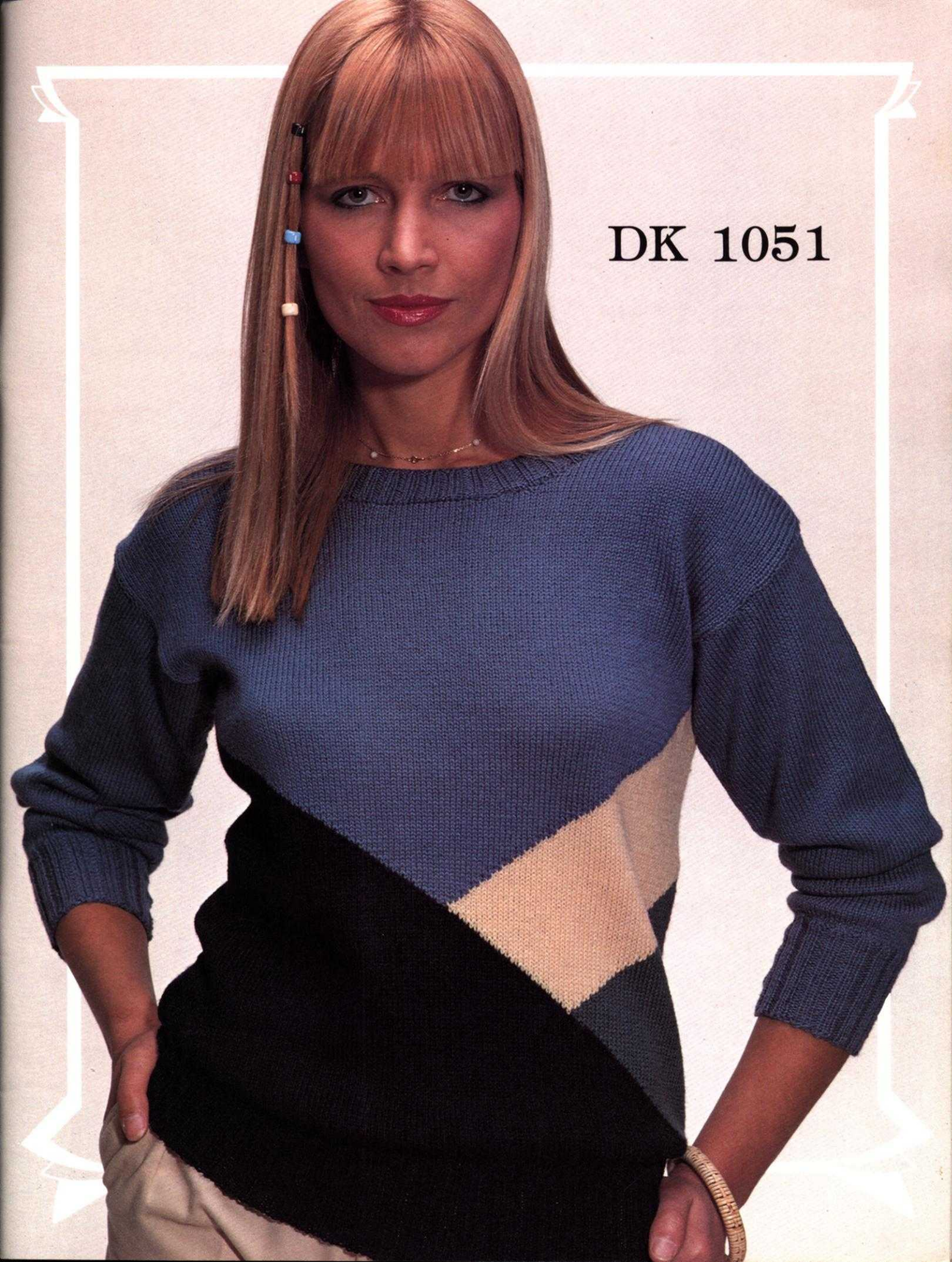

DK 1047

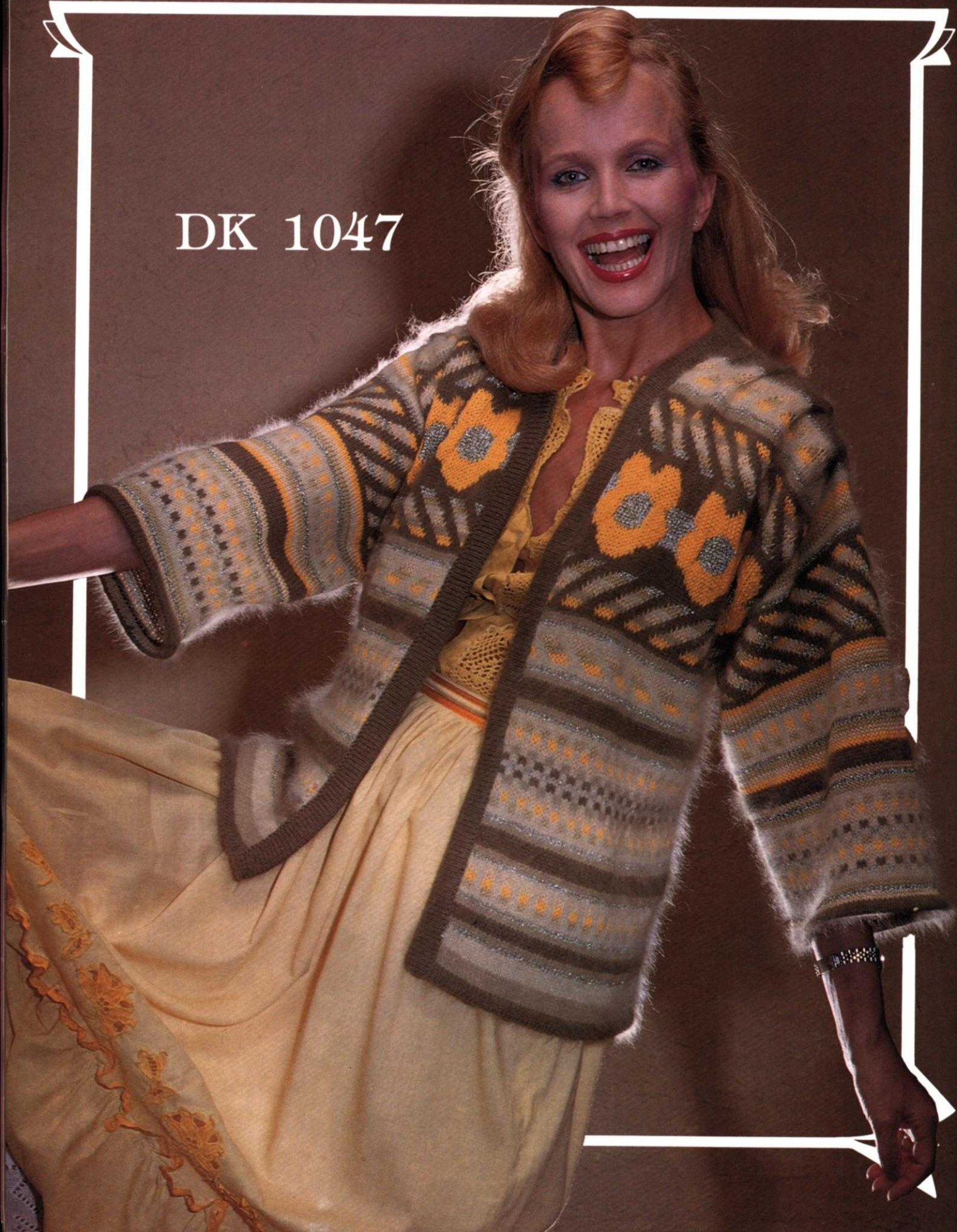

HP 1041

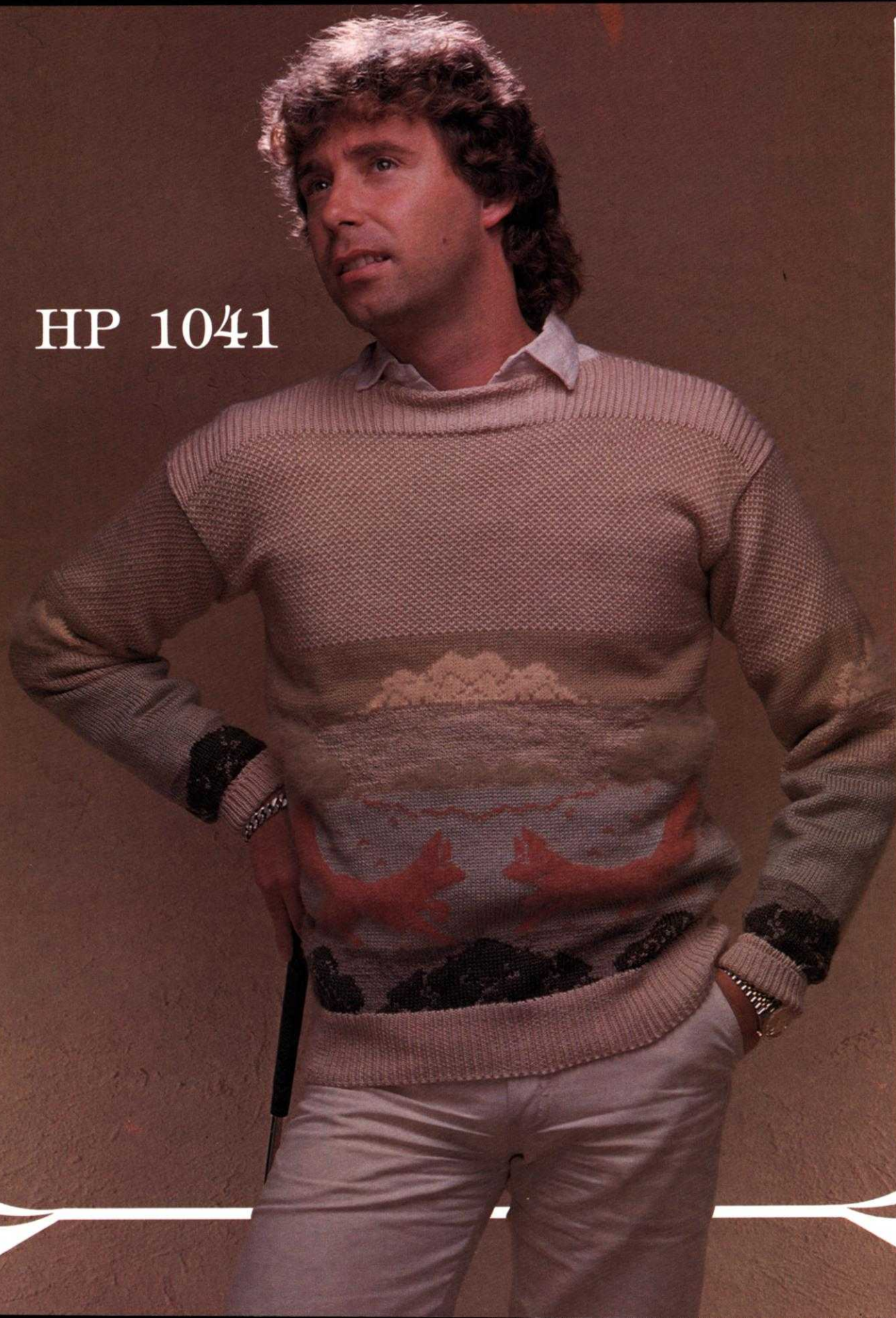

DK 1048



knitking

magazine

TABLE OF CONTENTS PAGE NO.

KK 1034 - Child's Pullover and Bermuda Shorts	14
KK 1035 - Child's Pullover and Bermuda Shorts	15
KK 1036 - Child's Jacket and Bermuda Shorts	16
KK 1037 - Child's Pullover	17
KK 1038 - Child's Pullover	19
KK 1039 - Child's Coveralls, Jacket and Cap.	20
KK 1040A- Child's Pullover	21
KK 1040B- Child's Pullover	22
HP 1041 - Man's Pullover	23
DK 1042 - Woman's Pullover	23
DK 1043 - Woman's Pullover	25
DK 1044 - Woman's Pullover	26
DK 1045 - Woman's Pullover -Cover Model	27
DK 1046 - Woman's Jacket	29
DK 1047 - Woman's Jacket	30
DK 1048 - Woman's Jacket	31
KK 1049 - Girl's Pullover	32
KK 1050 - Child's Pullover	33
DK 1051 - Woman's Pullover	34
KK 1052 - Child's Pullover	35
HP 1053 - Man's Sleeveless Pullover .	36

editorial

The rumor has existed for several years... and now the rumor has become a fact... SINGER has entered the knitting machine market in the U.S.A. and we are adding their excellent machines to the KNITKING range.

A network of Singer distributors is being set up throughout the U.S. and KNITKING currently has the west coast... So if you are a knitting machine dealer located in a western state, be sure to contact us for a portfolio of literature and information. Retail customers will be kept up-to-date through this Magazine and our regular Sale Literature. Knitting machines being made in the Singer Logo are manufactured by the Silver Seiko Company of Japan which also produces the same machines for the Studio Company of America.

The two largest knitting machine manufacturers in the world are Brother Industries of Nagoya and Silver Seiko of Tokyo Japan. Knitting machine owners in Japan are the most knowledgeable in the world and they invariably choose one or both of these famous brands. Both companies have a network of schools set up throughout Japan and both provide excellent services in the form of magazines, patterns, accessories etc. Both companies have world wide distribution centers and Singer has for many years successfully sold Silver machines in other countries of the world.

SUBSCRIPTION PRICE INCREASE

We have fought the inevitable for more than a year now, during that time there has been 3 increases in Postage costs, 2 general wage increases and 3 increases in printing costs.





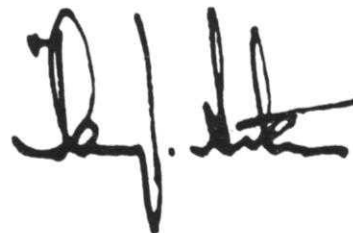









KNITKING MAGAZINE has never made a profit in its over 16 years of existence. We provide it as a service to our customers and despite the fact that special editions are printed for several other countries and the magazine is sold by subscription in 15 countries, we still refuse to accept outside advertising. We strive to maintain and improve upon the acknowledged quality of our publication and its contents and we truly believe that it is excellent value for money.



We will honor outstanding subscriptions at the old rate of \$15.00 for 6 issues. The new rate is \$18.00 for the U.S. and \$21.00 for all other countries.



Pattern Symbols

Knitting – Chart Symbols

- () Size Symbols (2nd Size)
- < > 3rd Size
- ① Color Number
-  Cast on
-  Stitch
- R Row
- H Hem
-  Bind off
-  Stockinette stitch – worn on the Knit side.
-  Stockinette stitch – worn on the Purl side.
-  Knit 1, Purl 1 Ribbing
-  Ribbing Pattern – worn on the Knit side.
-  Ribbing Pattern – worn on the Purl side.
-  Closed Dart
-  Open Dart
-  Put on a stitch holder
-  Reverse 1 section
-  On every other needle
-  Number of Rows between Shapings. Make increase (or decrease) FIRST, then knit 4 rows. For example: 3 x 1  means decrease (or increase) 1 st., knit 4 rows; decrease 1 st., knit 4 rows; decrease 1 st., knit 4 rows; decrease 1 st., knit 4 rows. All decreasing (or increasing) without row numbers as shown must be shaped on every 2nd row.

-  Increase
-  Increase 2 sts. With a transfer tool, move the sts. over the left (or right) leaving 2 empty needles at the point of increase. At the increase point, move 1 st. to the left, (or right) so that there is an empty needles on each side of a stitch. On each side of the center stitch, pick up a stitch from the row below and hang it onto the empty needle.

-  3 stitches on 1 needle. The 1st and 3rd stitch in a group of 3 has been hung on the 2nd or center needle.

-  Short Row increase or decrease; for instance on a flared skirt knitted sideways.

-  Pattern Stitch





-  Pattern Stitch – worn on the Knit side.

-  Pattern Stitch – worn on the Purl side.









-  Repeat

- I = Front
- II = Back
- III = Sleeve
- IV = Skirt Front
- V = Skirt Back
- VI = Collar
- VII = Pocket
- VIII = Band
- IX = Belt
- X = Cuff
- XI = Pants Front
- XII = Pants Back

Finishing – Chart Symbols

-  Match numbers on section for assembling.
-  Ease
-  Fold Line
-  Turn to the wrong side and hem.

Stitch Symbols

-  Needles in holding position
-  Needles back into working position.
-  Empty needle (leave in working position)
-  Needle not used (in the out of work position).
-  Two stitches on 1 needle, either transferred from the right side or the left side, then put into holding position.
-  Needle holding 2 stitches. Stitch has been transferred from the RIGHT.
-  Needle holding 2 stitches. Stitch has been transferred from the LEFT.
-  Center of garment section



General Instructions

HOW TO READ THE CHARTS AND INSTRUCTIONS

There are 3 sizes given for each Pattern in KNITKING MAGAZINE. Above each Chart for the different sizes, you will see that the first and smaller sizes might be shown as 8/10, the second size as [12/14] and the third as [16/18]. Check the measurements at the bustline and hips on the Charts to be certain that you will knit the correct size, remembering these are ACTUAL measurements of the completed section and that there must be a bigger allowance at the bustline and hipline for a Jacket or a Coat than there would be for a fitted dress or a fitted blouse or pullover. The question in your mind should be "How do I want this garment to fit...?"

When you have chosen the size you need, you can follow the Charts as shown. You will notice that where the shapings are the same FOR ALL SIZES, only 1 set of shapings will be shown on the first Chart and if you are knitting the 2nd or 3rd size, you simply follow the shapings as given for the first size. If the shapings are different, this will be shown on the Charts and you should follow them as given.

On the Charts, increases and decreases will be shown as follows

5x1
6 The number in the box means number of ROWS between the shapings, while the 5x1 above the box means - 1 st. 5x... so you will increase or decrease 1 st. every 6th row 5x.

ARMHOLE SHAPINGS - NECK SHAPINGS - SHOULDER SHAPINGS - are made on every 2nd row UNLESS there is a number in a box along side or below the shapings. The rule is... where there is no box with a number, the shaping is made on every 2nd row.

THE PRINTED INSTRUCTIONS

You can follow the printed instructions or use them in combination with the Charts. Where there is any question in the printed instructions, you have the Charts to show you how the section will look.

The 3 sizes, with the different amounts of cast on stitches and the different shapings will look like this...

Cast on 124 (136) [148] sts. You will
Cast on 124 sts. for the first size.
Cast on 136 sts. for the 2nd size.
Cast on 148 sts. for the 3rd size.

The important thing to remember is that you MUST READ AHEAD so that you KNOW what to do for the size you are knitting. Sometimes where the number of stitches are the same but the number of times different, you will find shapings like this... 3 sts. 1x (2x) [3x], 2 sts. 1x (2x) [3x], 1 st. 3x (4x) [5x]. As you see, you MUST read ahead in order to follow the instructions as given for YOUR SIZE. The rows will be different for the different sizes in some cases... Shoulder and Neck shapings usually are worked at the SAME TIME for the back section - so watch for the words AT THE SAME TIME.

HOLDING STITCHES ON THE LEFT SIDE WHILE SHAPING THE RIGHT SIDE

When knitting a section of garment in stockinette stitch, it is easy to hold the stitches on the left side while knitting the right half, but when knitting a Pattern Stitch such as a Norwegian Design, a Holding Position Design, Weaving, etc., you should use the following method. For the NECK SHAPING, we tell you to bind off the center sts., put the needles on the left into holding position and complete the right half first... so with a strand of contrast yarn, knit ALL of the left side stitches manually by hand, pulling each stitch back against the needle bed to the OUT OF WORK position. When the right side is completed, carefully pull the stitches held on contrast, forward into working position and as you do so, undo the contrast yarn, line up the needles (KNITKING AM 3 machine owners, put the stitches under the sinkers) and complete the left half.

If you own a Japanese machine, you may find that when knitting the right half with the left side held in this way, the sinker plate will mark the left side while you are knitting the right half. To prevent this marking, you can tape a piece of paper over the knitting, underneath the sinkers, or if you own a Reversing Bar, you can hang this onto the Sinkers while you are knitting the right half. When hanging the Reversing Bar, be sure the eyes of the bar go BETWEEN the Sinker Posts on the upper part of the bar so that the tips of the bar only - show above the needle bed.

FULL FASHION DECREASING OR INCREASING

For Stockinette stitch, always use the Full Fashion method for increasing or decreasing.

TO DECREASE: Hang the 3rd stitch onto the 2nd stitch then move the stitches in to fill the empty needle.

TO INCREASE: Move the 2 end stitches 1 needle outward, then pick up the 3rd stitch from the row below and hang it onto the empty needle.

FINISHING: Block all sections. For PULLOVERS, JACKETS, and DRESSES: Join front to back at sides and shoulders. Sew sleeves together and set in. Hem lower edge and sleeve edges if needed. For a double neckband or armhole band, sew 1 edge to the inside and 1 to the outside of neck or armhole. For a single ribbed band, sew 1 edge to the outside of neck or armhole edge. For a cardigan or jacket with buttonholes, finish buttonholes and sew on buttons.

PANTS: Join front to back at sides. Sew inside leg seams, then join center front and back. Make hem at waistline and insert elastic. Hem lower edge of pants legs.

THE SAMPLE SWATCH

Before you begin to knit any garment, you will need to knit a sample piece using the yarn you have chosen for your garment, so that you can check the stitch and row gauge which must measure the correct number of stitches and rows in 5 cm (2 inches).

For each Pattern in KNITKING MAGAZINE, we give you 3 tension numbers to work from and if you use the specified yarn for the garment, you should be able to get the correct stitch and row gauge using one of these numbers. Here is a very easy way to make your sample swatch and count the stitches and rows without actually counting, by using our KNITKING Converta Tape.

Supposing the Tension Numbers for the Stitch and Row Gauge are given as 5 to 7. Set the Tension Dial to the first number which is 5. With contrast waste yarn, and using the quick cast on method, cast on 60 stitches and knit 10 rows. Change to garment yarn and turn the Row Counter to 0. Knit 30 rows. Counting from each end, knit the 10th stitch on each side by hand with a small piece of contrast yarn. Leave the needles in working position and knit 30 rows (Row 60), then knit 4 rows with contrast waste yarn. Turn the Row Counter to 0 and the Tension Dial to 6 and with garment yarn, knit 30 rows. Mark the 10th stitch on each side as you did before, knit 30 rows, then 4 rows with contrast waste yarn. Turn the Row Counter to 0 and with Tension 7, repeat the above once more, ending with 10 rows of contrast waste yarn. Remove the work from the machine by passing the Slide across the needles without yarn (sometimes called 'dropping').

Pull and stretch the sample piece both lengthwise and diagonally from corner to corner, then lengthwise again. Do not count the stitches and rows immediately, but allow the sample to rest for several hours or even over night. This will allow the stitches and rows to return to their basic form.

When your sample has rested and you are ready to count the stitches and rows, the KNITKING CONVERTA TAPE will do the counting for you without any counting on your part. Use the Tape as follows:

Measure the stitches with the TAPE, BETWEEN the 40 stitches marked with contrast waste yarn. Push the SLIDE so that the LEFT EDGE lines up to this exact measurement. Now look down along side the SLIDE and find the number 40 on the TAPE. The number directly opposite on the SLIDE will be your Stitch Gauge to 5 cm (2"). To find the number of rows in 5 cm (2"), place the TAPE to measure over the 60 rows, push the SLIDE to this number with the left edge lined up, the look for the number 60 on the TAPE and directly opposite this will be the number of rows to 5 cm (2")

If you do not own a KNITKING CONVERTA TAPE, you must mark a 5 cm (2 inch) square in the center of the knitting, then count the number of stitches and rows within the square.

KK1034

CHILD'S PULLOVER & BERMUDA SHORTS

SIZE: 4/5
 YARN: Amore
 GRAMS:
 color 1 150
 color 2 50
 color 3 50
 color 4 50
 color 5 50
 TENSION: 6 or 7
 GAUGE: 12 sts. 20 rows = 5 cm (2")

A Norwegian Design with color stripes. Punch your own Card.

FINISHING: See General Instructions. Sew center seam of pants to marking. Make hem at waist then pull elastic through casing. Overlap back over front shoulder - 10 cm (4") See Picture. then sew in sleeves.

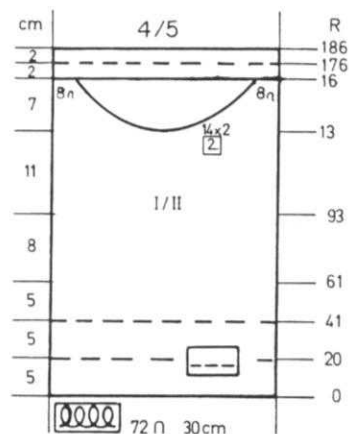

FRONT & BACK: I/II Both sections the same.

Bring 72 needles into working position then push back to the out of work position every 3rd needle for a MOCK RIB.

With waste yarn, cast on over the remaining needles in work.

Work Stockinette stitch. Knit 8 to 10 rows, then change to color 1 and put Counter at 0. Work 20 rows color 1 and work the color stripes as follows:

6 rows color 1, 2 rows color 2, 2 rows color 3, 2 rows color 4, 2 rows color 5, 6 rows color 1.

Bring all the empty needles into working position and hang the hem.

Continue in Stockinette stitch with color 1 to Row 61. Put in Bear Punch Card and set the first row of Pattern from left to right then work the Bear (Norwegian Technique) design with color 1 and 2. When Bear is completed, continue in Stockinette stitch with color 1.

After Row 93, mark each side for setting in sleeves.

After Row 138, put half the sts. on the left into holding position and complete the right side first.

*ON NECK SIDE, (using SHORT ROWS for shaping neck), put into holding position 2 sts. 14x. Put all these sts. into holding position, and work the left half. Knit 1 row across (from center to left side) over the needles, then turn the Row Counter to 138 and complete the left half, following the instructions from *.

After Row 166, bring all the needles into working position and work the color stripes of 2 rows color 5, 2 rows color 4, 2 rows color 3, 2 rows color 2, 2 rows color 1.

Hang every 3rd st. onto neighboring needle and with color 1, work 10 rows. Hang the hem (first row of band color) or you can sew the band down to the inside later. Bind off loosely.

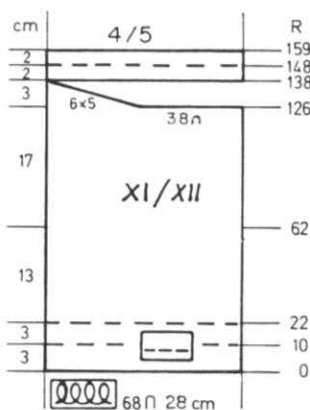
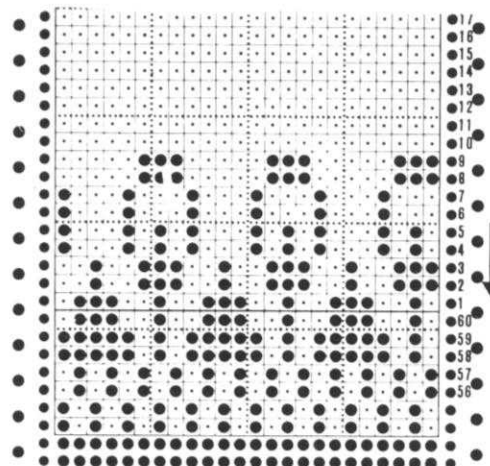
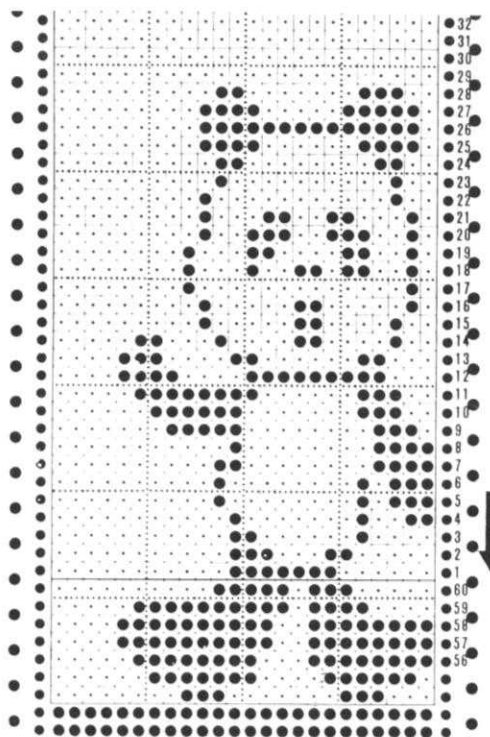

SHORTS: Make 1, reverse 1 -XI/XII

Bring 68 needles into working position, then push back EVERY 2nd NEEDLE to the OUT OF WORK position.

With Waste yarn, cast on over the remaining needles. Knit 8 to 10 rows then change to color 5 and put Counter at 0.

Knit 10 rows, then work the color stripes of

2 rows color 5, 2 rows color 4, 2 rows color 2, 2 rows color 3, 2 rows color 5, 2 rows color 1.

Bring the empty needles into working position and hang the hem.

Put in Flower Card.

Work 4 color 1, setting the Card after Row 3 (from left to right).

Work 10 Rows colors 1 & 4,

6 rows colors 1 & 3.

STOP CARD. Continue in Stockinette stitch with stripes of

*4 rows color 1, 4 rows color 5,

4 rows color 2, 4 rows color 3,

4 rows color 4.

REPEAT THE STRIPES from * 3x and mark each side after Row 62.

Work 4 rows color 1 then continue with color 5.

After Row 127, work SHORT ROWS:

Put into holding position 38 sts.

then 5 sts. 6x.

Bring all the needles into working position and knit the band.

With color 1, knit 10 rows.

Transfer every 3rd st. to neighboring needle and knit 10 rows.

Hang the hem then bind off loosely.

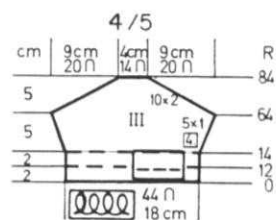

SLEEVES: III

Bring 44 needles into working position then push back every 3 needle to the out of work position.

Cast on over the remaining needles with waste yarn. After knitting 8 to 10 rows, change to color 1 and work 12 rows Stockinette stitch. Work the 10 rows of color stripes same as front and back, then bring all empty needles into working position and hang the hem.

Continue in Stockinette stitch with color 1.

ON EACH SIDE, increase 1 st. every 4th row 5x.

After Row 64, ON EACH SIDE, bind off 2 sts. 10x.

After Row 84, bind off the remaining stitches.

KK1035

CHILD'S PULLOVER WITH BERMUDA SHORTS

SIZE: 4/5
 YARN: Amore
 GRAMS:
 color 1 200
 color 2 100
 color 3 50
 TENSION: 3 to 6
 GAUGE: 14 sts. 18 rows = 5 cm (2")



A Norwegian Design with color stripes. Punch your own Card. Bands are Mock Ribbing.

FINISHING: See General Instructions. Bring back forward over front neckline approximately 10 cm (4") as shown in picture. Shorts: Fold each section and sew up leg seam for 17 cm (7"). Sew front and back seams. Pull elastic through casing at waist.

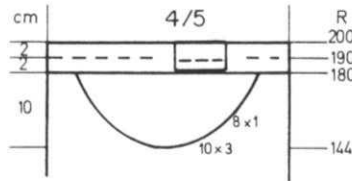

FRONT: I

Work the front the same as the back to Row 144. Put half the sts. on the left into holding position and complete the right side first. *ON NECK SIDE, put into holding position 3 sts. 10x, 1 st. 8x. After Row 180, put all these sts. into holding position and bring the Carriage to the left side. Turn the Row Counter back to 144 and leave the RIGHT HALF sts. in holding position and push the left side sts. to working position. Work the Short Rows the same as the right side, following the instructions from *. After Row 180, bring all the needles into working position. Transfer every 3rd stitch to neighboring needle and work the Mock Rib band same as you did for the back.

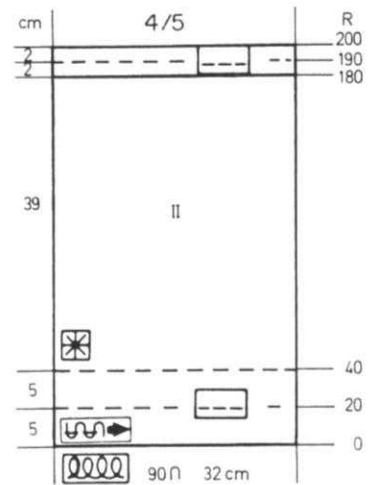
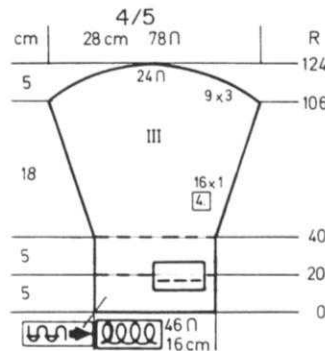

BACK: II

Bring 90 sts. into working position. Push every 3rd st. back to the out of work position and with waste yarn Cast on over the remaining sts. Knit 8 to 10 rows, then change to color 1 and put Counter at 0. Knit 24 rows color 1, then 2 rows color 3, 2 rows color 2, 2 rows color 3, 2 rows color 2, 2 rows color 3, 6 rows color 1. After Row 40, bring the empty needles into working position and hang the hem. Continue in Stockinette stitch and PATTERN II.

*Work 12 rows Stockinette stitch with color 1, then work the FLOWER SECTION of Pattern II with 10 rows using colors 1 and 3, then 6 rows with colors 1 and 2. REPEAT from * 1 time more, then **work 12 rows Stockinette stitch with color 1 then work the FLOWER of Pattern I with 5 rows using colors 1 and 3 then 3 rows with colors 1 and 2. REPEAT from ** 1 time more then knit to Row 180 with color 1. Transfer every 3rd stitch to neighboring needle and work Mock Rib with 4 rows color 3, 2 rows color 2, 4 rows color 3, 10 rows color 1, then hang the hem and bind off loosely.

SLEEVES: III

Bring 46 needles into working position and push back every 3rd to the out of work position. Cast on over the remaining needles with waste yarn. Knit 8 to 10 rows, then change to color 1 and put Counter at 0. Work the 40 rows of Stripes same as you did for the front and back then bring the empty needles into work and hang the hem. Continue in Stockinette stitch with color 1. ON EACH SIDE, increase 1 st. every 4th row 16x. After Row 106, SHAPE CAP. ON EACH SIDE, bind off 3 sts. 9x. After Row 124, bind off the remaining sts.

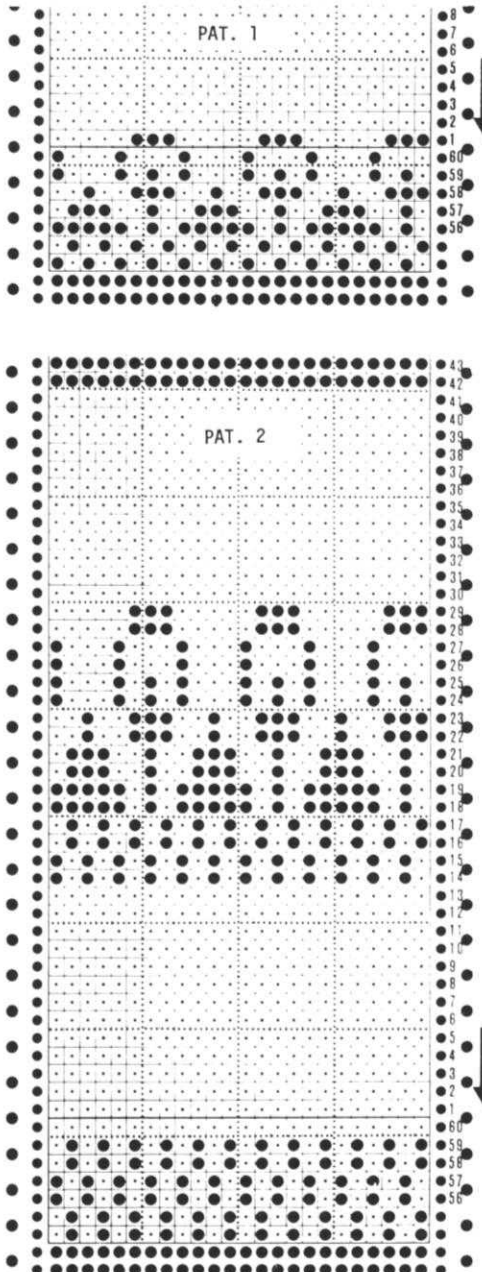

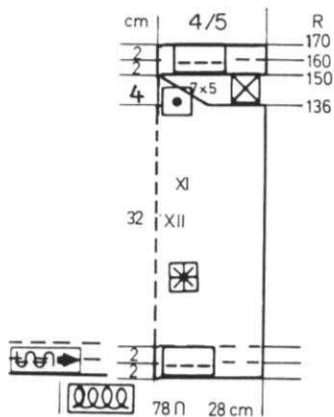

SHORTS: XI/XII - Front & Back.
Make 1, reverse 1.

Bring 78 needles into working position then push back every 3rd needle to the out of work position. With contrast waste yarn, cast on over the remaining needles. Knit 8 to 10 rows, then change to color 1 and put Counter at 0. Knit 10 rows color 1. Bring the empty needles into working position and continue in Stockinette stitch with stripes of 2 rows color 1, 2 rows color 3, 2 rows color 2, 2 rows color 3, 2 rows color 1. Hang the hem then work 4 rows color 1.

Work PATTERN II right from the beginning - 2 rows color 1 and 3, 2 rows color 1 and 2, 2 rows color 1 and 3. Work the stripes in Stockinette stitch - 2 rows color 1, 4 rows color 2, 4 rows color 3, 4 rows color 1 - work the FLOWER PATTERN - 10 rows colors 1 and 3, 6 rows colors 1 and 2. Continue in REPEATED color stripes of 4 rows color 3, 4 rows color 2, 4 rows color 1. After Row 137, ON OPPOSITE SIDE of Carriage, put into holding position 35 sts. then on every 2nd row, put into holding position, 5 sts. 7x. Bring all the needles into working position and mark the next row for hem then knit to Row 170. Hang the marked row and bind off loosely. Be sure to REVERSE the shaping on 2nd section.

KK1036

CHILD'S JACKET & BERMUDA SHORTS

SIZE: 4/5
YARN: Amore
GRAMS:
color 1 150
color 2 100
color 3 50
color 4 50
color 5 50
TENSION: 6 or 7
GAUGE: 14 sts. 18 rows = 5 cm (2")



A Norwegian Design and Stockinette stitch with color stripes. Punch your own Card. Bands are Stockinette stitch with color stripes.

FINISHING: See General Instructions. Make heavy twisted cords to pull through neck and waist casings. SHORTS: Sew up 5 1/2" (14 cm) for leg seams then sew front and back seams. Make hem at waist if you did not hang the hem then pull elastic through casing.

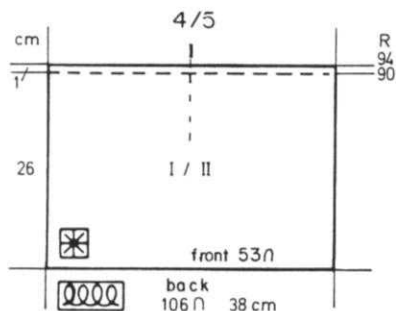

JACKET BACK: II

With contrast waste yarn, cast on 106 sts. Knit 8 to 10 rows then change to color 1 and put Counter at 0. Knit 6 rows color 1, then work the Norwegian Design with colors 1 & 2. After Row 90, bind off or remove onto waste yarn, center 54 sts. Put the left side into holding position and work the right saddle shoulder as follows in Stockinette stitch.
*4 rows color 1, 4 rows color 2, 4 rows color 3, 4 rows color 4, 4 rows color 1. Bind off or remove onto waste yarn. Bring the needles on the left into working position and REPEAT from * for left shoulder.

JACKET FRONT: I Make 1, reverse 1.

Cast on 53 sts. using waste yarn same as you did for the back. After knitting 8 to 10 rows, change to color 1 and put Counter at 0. Knit 6 rows color 1 then work the Norwegian Design with color 1 and 2 to Row 74. ON NECK SIDE, bind off 5 sts. 1x, 3 sts. 1x, 2 sts. 4x, 1 st. 2x. After Row 90, continue in Stockinette stitch with color 1 to Row 94. Bind off - or you can hang 1 shoulder of back to the remaining sts. and then bind them off together.

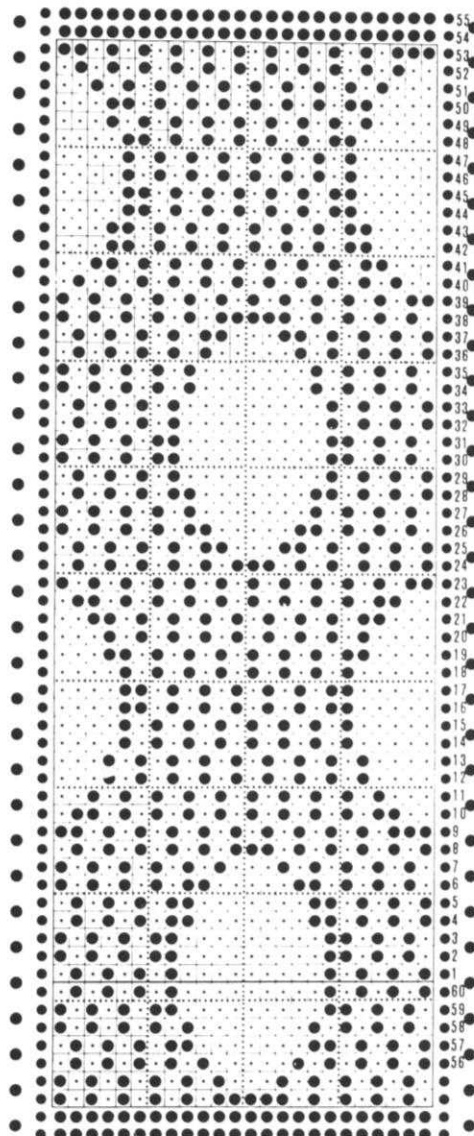

SHORTS: XI/XII Make 1, reverse 1.

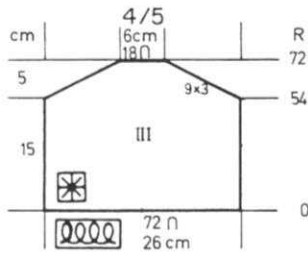

SLEEVES: III

Cast on 72 sts. using waste yarn same as you did for front and back. Work the same as front and back to Row 54.
SHAPE CAP: ON EACH SIDE, bind off 3 sts. 9x.
After Row 72, bind off the remaining stitches.

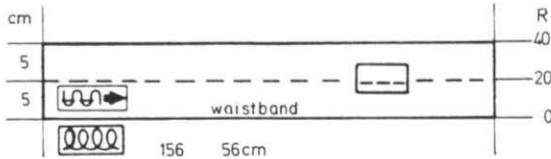

WAISTBAND: Sew side seams of Jacket first.

Cast on 156 sts. with color 1 and work Stockinette stitch with color stripes as follows: 24 rows color 1, 4 rows color 4, 4 rows color 5, 4 rows color 3, 4 rows color 2. Hang the hem and then hang the open sts. of Jacket waist to these sts. doubling the sts. evenly as needed. Bind off loosely. Another way you can do is to knit the band and do not hang the hem but hang the Jacket waist to the one set of sts. bind off then sew the other edge of band to the inside.

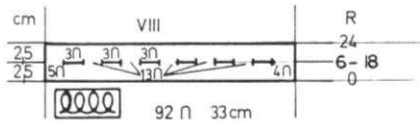

FRONT BANDS: Make 1 and 1 without BUTTONHOLES.

Cast on 92 sts. and work Stockinette stitch with color stripes same as Neckband. After Row 24, finish same as Neckband. Make Buttonhole band the same except make BUTTONHOLES after Rows 6 and 18 over 3 sts. leaving 5 sts. at one end and 4 at other end with 13 sts. between each buttonhole as shown on the Chart. After Row 24, complete same as button band.

GR. 98-104

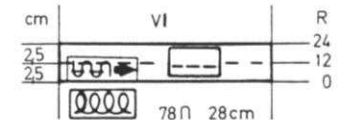
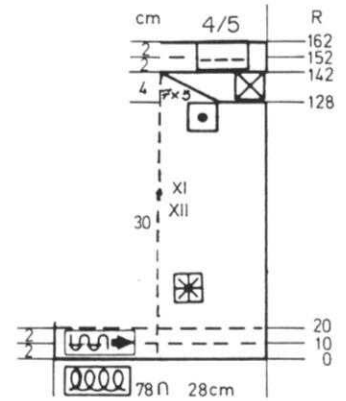

NECKBAND: VI

Cast on 78 sts. and work Stockinette stitch with color stripes as follows: 12 rows color 1, 2 rows color 2, 2 rows color 3, 2 rows color 5, 2 rows color 4, 2 rows color 1. Finish same as waistband.

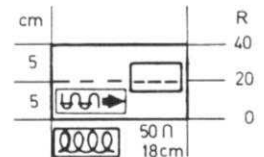

SLEEVE BANDS:

Cast on 50 sts. with color 1 and work Stockinette stitch with color stripes same as the Waistband. After Row 40, finish off same as you did for the Waistband.

KK1037

BOY'S PULLOVER

SIZES: 10/12 (14)
YARN: Any combination of yarns that will give you stitch and Row Gauge and include some Angora in Natural color.
GRAMS: Approximate
color 1 150 200
colors 2, 3, 4, 5, 6, 7, 8, 9, 10 - 50 grams each
NO KIT AVAILABLE.
TENSION: 5 or 6
GAUGE: 13 1/2 sts. 18 rows = 5cm (2")



Made on the Electronic Machine. Send 50¢ for original copy of Pattern Design. If you own a Punch Card Machine, you can knit the Pullover by substituting a Punch Card of your choice. Bands are Mock Ribbing.

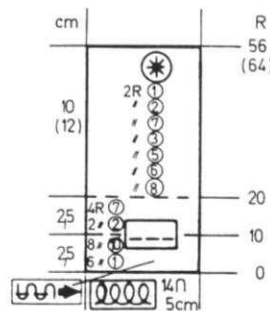

SADDLE SHOULDER STRIPS: Make 2.

Bring 14 needles into working position and push back every 3rd needle to the out of work position. Cast on and work the Mock Rib same as you did before, working the color stripes as shown on the Chart. After Row 20, bring all needles into work, then continue Stockinette st. with color stripes as shown on the Chart. After Row 56 (64), bind off.

FINISHING: See General Instructions.

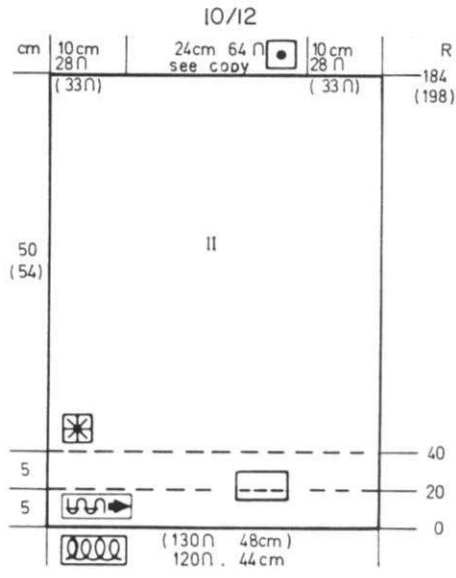
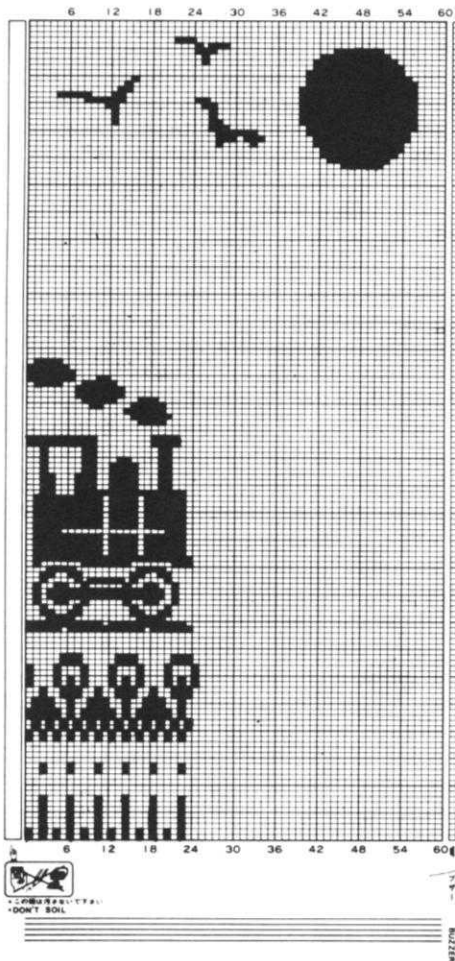

BACK: II

Bring 120 (130) needles into working position then push back every 3rd needle to the out of work position. With contrast waste yarn, cast on over the remaining needles in work. Knit 8 to 10 rows, then change to color 2 and put Counter at 0. Knit in color stripes as follows. 29 rows color 2, 2 rows color 10, 2 rows color 8, 2 rows color 6, 1 row color 5, 2 rows color 3, 2 rows color 7. Bring the empty needles into working position and hang the hem. Work 6 rows color 2, then work in Pattern. 8 rows colors 2 and 4, 2 rows color 4, 2 rows color 2, 2 rows colors 2 and 4, 4 rows color 2, 10 rows colors 2 and 5, 6 rows colors 2 and 8, 2 rows color 2, 2 rows color 7, 10 rows colors 7 and 3, 26 rows colors 7 and 6, 2 rows color 1, 12 rows colors 1 and 10, 28 rows color 1, 25 rows colors 1 and 10 plus 9. Continue with color 1 to Row 184, 198. SHAPE SHOULDER AND NECK. ON EACH SIDE, bind off 28 (33) sts. then over the center 64 sts. transfer every 3rd st. to the neighboring needle and continue in color stripes of 4 rows color 7, 2 rows color 2, 8 rows color 10, 6 rows color 1. Hang the hem for band and bind off loosely.

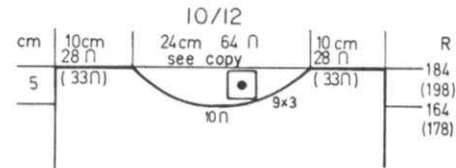

FRONT: I

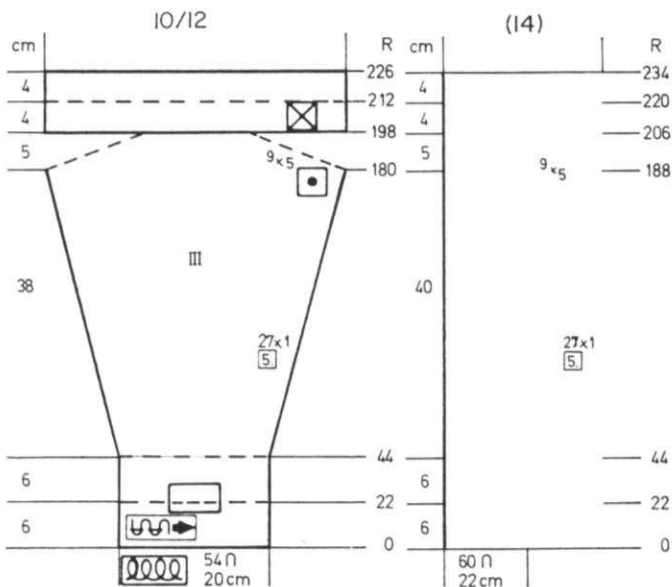

SLEEVES: III

Bring 54, (60) needles into working position and push back every 3rd needle to the out of work position. Use the same cast on as you did for the front and back then after the waste knitting, put Counter at 0 and work color stripes for the mock rib as follows: 32 rows color 1, 4 rows color 3, 4 rows color 2, 4 rows color 7. Bring the empty needles into working position and hang the hem. Continue in Color 1 and Stockinette stitch. ON EACH SIDE, increase 1 st. every 5th row 27x. After Row 180 (188), work short rows. ON EACH SIDE, put into holding position 5 sts. 9x. After Row 198 (206), bring all the needles into working position and transfer every 3rd st. to neighboring needle for Mock Ribbing. Work Color stripes of 12 rows color 1, 2 rows color 7, 2 rows color 2, 12 rows color 3. Hang the mock rib band then bind off or remove onto waste yarn. Sew sleeve to armhole as shown in picture.

Work the front the same as the back to Row 164 (178). Put the 10 center sts. into holding position then all the needles to the left of the 10 sts. into holding position. Complete the right side first. *ON NECK SIDE, put into holding position 3 sts. 9x (short rows). After Row 184 (198) bind off the 28 (33) shoulder sts. Leave 37 sts. on the right in holding position then work the left neck shaping using short rows as you did for right side, following the instructions from *. When you complete the shoulder bind off, bring all the needles for neck into working position and transfer every 3rd st. to neighboring needle and work the mock ribbing with color stripes same as the back neckband. Hang the hem and bind off.

KK1038

CHILD'S PULLOVER

SIZES: 8/10 (12)
 YARN: Amore plus small
 GRAMS: amount Silver.
 color 1 200 200
 color 2 100 100
 color 3 50 50
 color 4 50 50
 color 5 Silver - small amt.
 TENSION: 3 to 6
 GAUGE: 15 sts. 19 rows = 5 cm (2")



PAT. 1

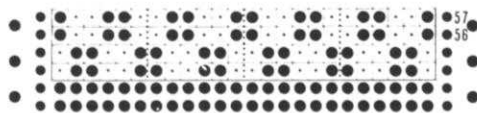

Continue to punch Card through Row 37, then punch 2 rows of holes for connecting Card.

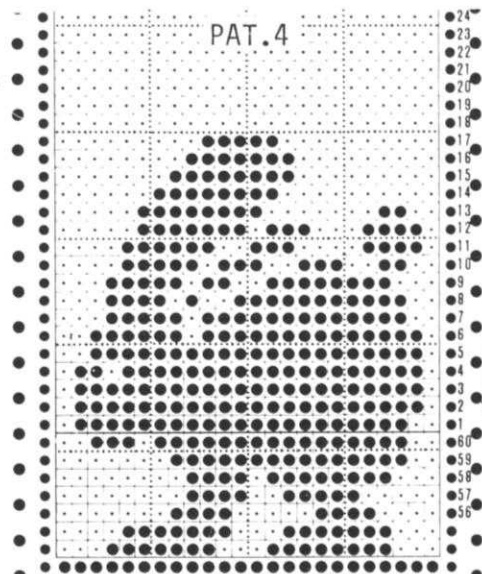

There are 4 Punch Cards used for this Pullover and you must follow the printed instructions for their use with color stripes. Sleeve and lower bands are K1, P1 Ribbing.

FINISHING: See General Instructions. Fold neckband to the inside and sew in place.

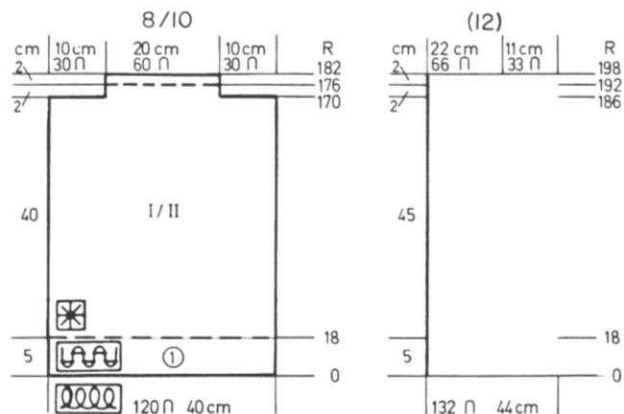
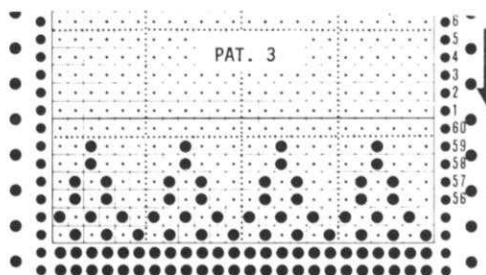
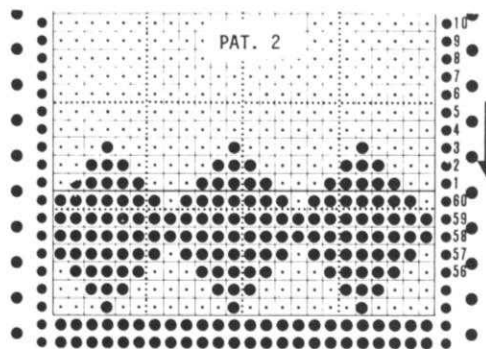

BACK & FRONT: I/II Both sections the same.

Cast on 120 sts. with color 1 and 18 rows Ribbing. Transfer the Ribber sts. to main machine and continue in Pattern as follows.
 Work 36 rows PATTERN 1 with colors 1 and 2.
 1 row color 3, 2 rows color 1, 2 rows color 3, 1 row color 1
 10 rows Pattern 2 with colors 1 and 2.
 2 rows color 1.
 10 rows Pattern 2 with color 1 and 2.
 1 row color 1, 1 row color 3, 2 rows color 3.
 6 rows Pattern 3 with colors 1 and 2.
 2 rows color 1.
 24 rows Pattern 4 with colors 1 and 4 plus silver added to color 4.
 2 rows color 1, 1 row color 3, 2 rows color 1, 2 rows color 3, 1 row color 1
 10 rows Pattern 2 with color 1 and 2.
 2 rows color 1
 10 rows Pattern 2 with color 1 and 2.
 2 rows color 1
 Continue in Pattern I with color 1 and 2 to Row 170 (186).
 ON EACH SIDE, bind off 30 (33) sts. then continue in Stockinette stitch with color 1.
 After Row 182 (198), bind off the remaining sts.

SLEEVES: III

Cast on 66 (78) sts. with color 1 and work 18 rows Ribbing. Transfer the ribber sts. to the main machine and continue in Pattern as follows:
 Work 1 row color 1, 1 row color 3, 2 rows color 1, 2 rows color 3, 6 rows Pattern 3 with colors 1 and 2, 2 rows color 1, 24 rows Pattern 4 with colors 1 and 4 (silver in with color 4) Continue in Stockinette stitch with color 1 to Row 120 (130).
 Work 10 rows Pattern 2 with colors 1 and 4 (plus silver in with 4) 1 row color 1, 1 row color 3, 2 rows color 1, 2 rows color 3 then work 16 rows Pattern 1 with colors 1 and 4.
 After Row 152 (166) bind off.

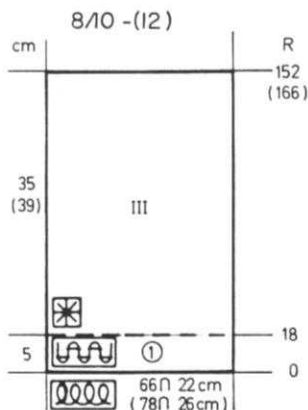

KK1039



JACKET FRONT: I

CHILD'S COVERALLS, JACKET AND CAP

SIZES 4/6 (8)
YARN: Any yarn to give stitch and row gauge.

color 1 = 2-ply Mohair or blend.
color 2 = Blue Lurex (Jacket trim)
color 3 = Red Amore
color 4 = Red Lurex (Star on Pants)
color 5 = White 2-ply Mohair or light weight Angora blend for Lamb and Bib trim.

NO KIT AVAILABLE
TENSION: 5 to 10
GAUGE: Jacket: 12 1/2 sts. 18 rows = 5 cm (2")
Pants & Hat: 13 1/2 sts. 18 1/2 rows = 5 cm.

Knitted on the Electronic Machine. Send 50¢ for copy of original drawing. Punch Card machine owners can use a suitable Punch Card of your choice for the designs. Bands are K1, P. Ribbing.

FINISHING: See General Instructions. Sew on Sequins and pearls as shown in Picture.

Cast on 48 (53) sts. with color 1 and work 20 rows Ribbing same as you did for the back. Continue in Stockinette stitch for 4 rows, then work the Moon and Star Design (or design of your choice) twice - centering it in the middle of front. After Row 92 (102), SHAPE ARMHOLE same as the back and AT THE SAME TIME, SHAPE NECK by decreasing 1 st. every 3rd row 18x (20x). After Row 146 (160), SHAPE SHOULDER same as the back.

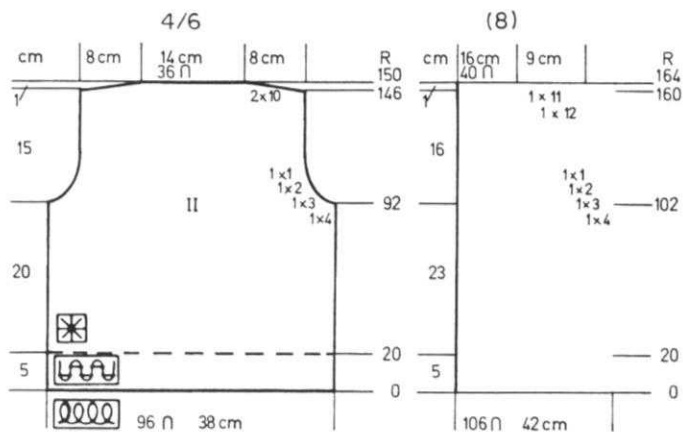
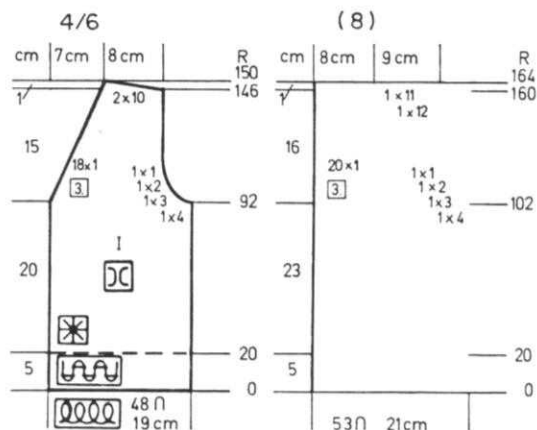

JACKET BACK: II

Cast on 96 (106) sts. with color 1 and work K1, P1 Ribbing with 2 rows color 1, 2 rows color 2. After Row 20, transfer the ribber sts. to main machine and continue in Stockinette stitch. Knit to Row 92 (102). SHAPE ARMHOLE: ON EACH SIDE, bind off 4 sts. 1x, 3 sts. 1x, 2 sts. 1x, 1 st. 1x. (4 sts. 1x, 3 sts. 1x, 2 sts. 1x, 1 st. 1x). After Row 146 (160), SHAPE SHOULDER: ON EACH SIDE, bind off 10 sts. 2x. (12 sts. 1x, 11 sts. 1x). After Row 150 (164), bind off the remaining sts.

CAP:

Cast on 60 sts. with color 3 and work Stockinette stitch with SHORT ROWS. ON EVERY 2nd row, put into holding position 2 sts. 15x. REVERSE the Short Rows - bring back 2 sts. 15x. REPEAT the Short Rows 4x. With color 4 (Red Lurex) knit 36 rows. Bind off. Roll the lurex edge to the outside and pad it a bit to form a roll and sew in place.

SHOULDER STRAP:

Cast on 20 sts. with color 3 and work Stockinette stitch for 74 cm (29"). Remove onto waste yarn. Fold in half and sew seam. Sew 1 edge to top of Bib, adjust length (pull out rows if needed) then close end. Sew on Button and make loop under Bib trim on other side to fit button.

BANDS FOR BIB AND BELT.

BIB: Cast on 7 sts. with white and knit Stockinette stitch for 48 cm (19"). Sew in place as shown in picture. BELT: Cast on 7 sts. with white and knit 120 cm (47") long. Knot at each end.

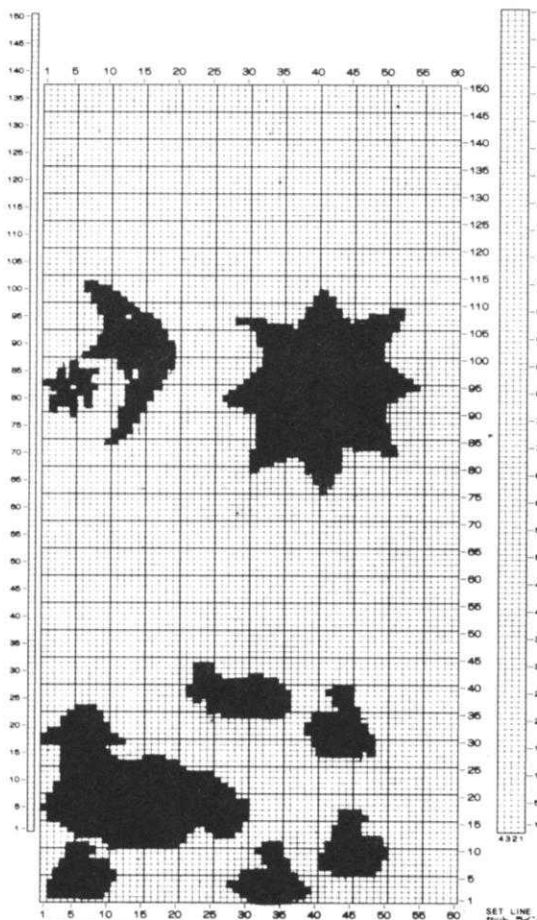

KK1039

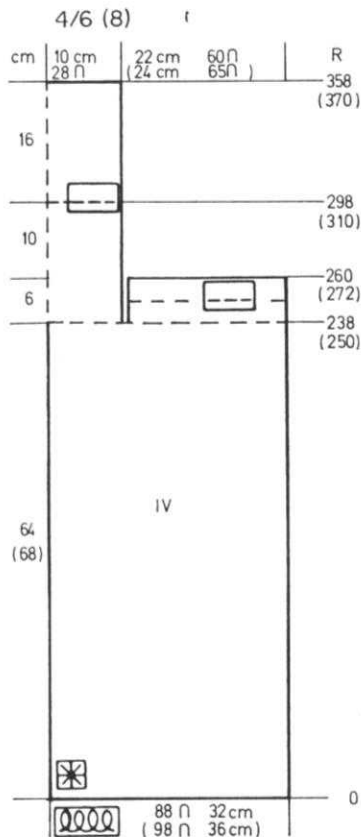

JACKET SLEEVES: III

Cast on 56 (60) sts. with waste yarn. After knitting 8 to 10 rows, change to color 1 and put Counter at 0. Knit in Stockinette stitch to Row 90 (98). SHAPE CAP: ON EACH SIDE, bind off 3 sts. 1x, 2 sts. 1x, 1 st. every 4th row 11x, 2 sts. 2x, 3 sts. 1x. (3 sts. 1x, 2 sts. 1x, 1 st. every 4th row 12x, 2 sts. 2x, 3 sts. 1x). After Row 144 (156), bind off the remaining sts. Hang the sts. held on waste yarn back onto the machine, decreasing to 46 sts. Work 2 rows color 1, 2 rows color 2 in Ribbing for 10 rows, then bind off.

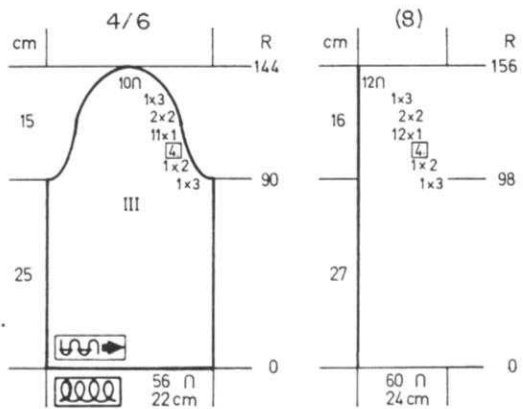

COVERALLS: IV Make 1, reverse 1.

Cast on 88 (98) sts. with color 3 and work Stockinette stitch with large Star Pattern (or pattern of your choice) in color 4 (Red Lurex). Isolate the pattern, placing them where you wish. After Row 238 (250), remove 28 sts. onto a stitch holder. Mark the row for hanging the hem. Knit to Row 260 (272) then hang the hem. Make 2nd section with reverse shaping. BIB: Pick up the 56 sts. for bib from the stitch holder and work the Lamb Pattern (or pattern of your choice with DOUBLE white yarn. Mark Row 298 (310) then continue in Stockinette stitch to Row 358 (370). Bind off or you can hang the hem and then bind off.

KK1040A

CHILD'S PULLOVER

SIZES: 8/10 (12)
 YARN: Amore
 GRAMS:
 color 1 200 200
 color 2 100 100
 color 3 50 50
 TENSION: 5 to 7
 GAUGE: 16 1/2 sts. 20 rows = 5 cm (2")



Stockinette stitch with color stripes and Norwegian Design. Punch your own Card. Waistband is Mock Ribbing.

FINISHING: See General Instructions.

ARMBANDS:

Sew shoulder seams first then Bring 106 sts. into working position and push back to the out of work position every SECOND NEEDLE. Hang the armhole to these needles and work Stockinette stitch with color stripes of - 2 rows color 1, 2 rows color 2, 3 rows color 3, 2 rows color 2, 3 rows color 1, 2 rows 2, 2 rows color 1. Bind off.

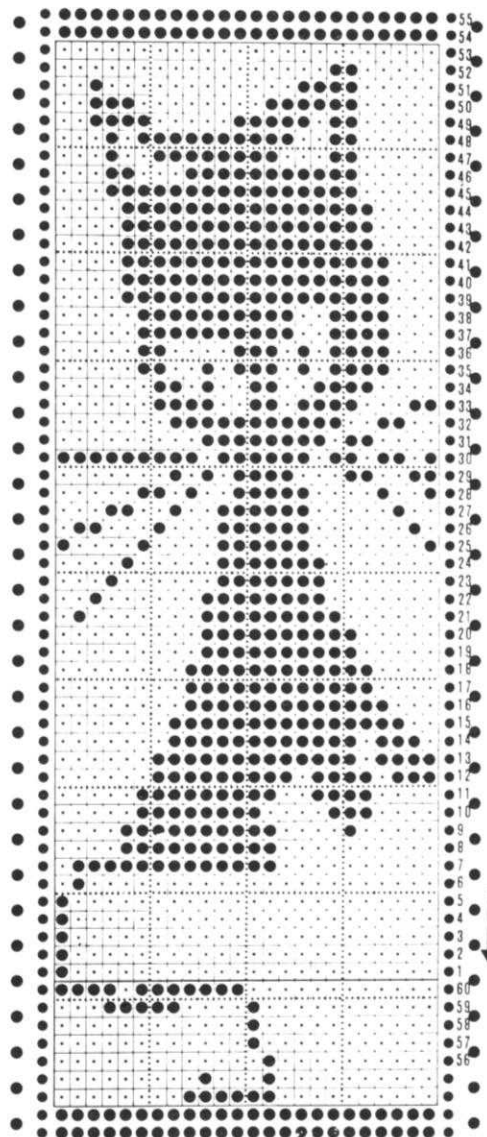

KK1040A

BACK & FRONT: Both Sections the same.
I/II

Bring 126 (138) needles into working position then push back to the out of work position, every 3rd needle (MOCK RIB). With contrast waste yarn cast on over the remaining needles. After knitting 8 to 10 rows, change to color 1 and put Counter at 0. Work Stockinette stitch with color stripes of 32 rows color 1, 4 rows color 2, 4 rows color 1, 2 rows color 2, 6 rows color 1. Bring the empty needles into working position then hang the hem. Continue in Stockinette stitch with color 1. After Row 120 (136), work 2 rows color 2, 4 rows color 3, 2 rows color 2, 4 rows color 1, then work the Cat Design with colors 1 and 2. Work 4 rows color 1, 2 rows color 2, 4 rows color 3, 2 rows color 2, 4 rows color 1 and after Row 216 (232), ON EACH SIDE, bind off 40 (43) sts. With color 1, knit 4 rows, then transfer every 2nd st. to neighboring needle, leave empty needles in work (picot edge), knit 4 rows then hang the hem.

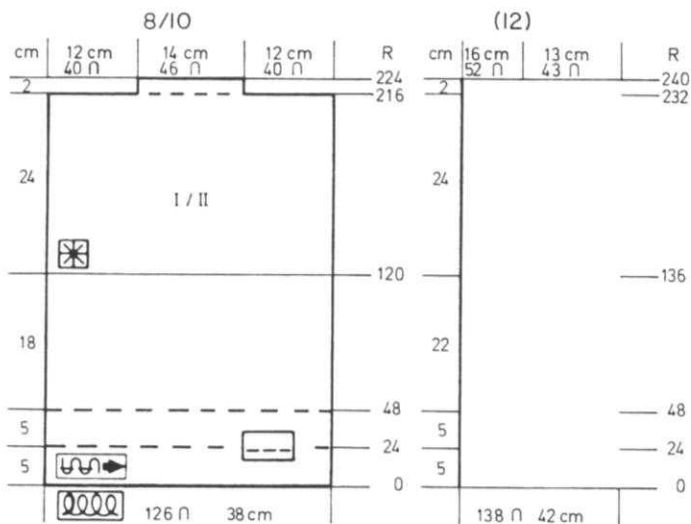

KK1040 B

CHILD'S PULLOVER

SIZES: 8/10 (12)
YARN: Amore and Mami Rex
GRAMS:
color 1 200 200 (Amore)
color 2 100 100 (Amore)
color 3 1 Spool for both sizes
(Mami Rex - Rainbow Color)
TENSION: 6 to 8
GAUGE: 15 sts. 19 rows = 5 cm (2")



Color 1 and color 3 (Mami Rex) are used together for the background color to give the pullover some sparkle. Punch your own Card for the Norwegian Designs. Electronic machine owners can add a large elephant alongside smaller elephant as shown in picture. Punch Card machine owners, put in 2 small elephants to one side of front at the waist level. Bands are knitted over every 2nd needle.

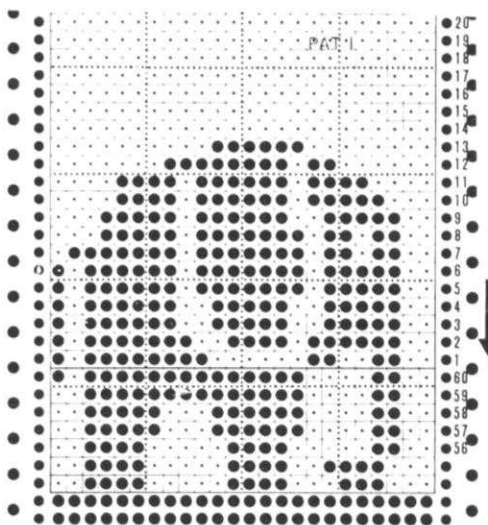

NECKBAND:

Sew 1 shoulder seam. Bring 128 needles into working position then push back every 2nd needle to the out of work position. Pick up the sts. around neckline doubling the sts. With color 1 and 3 together, knit 20 rows, then hang the hem.

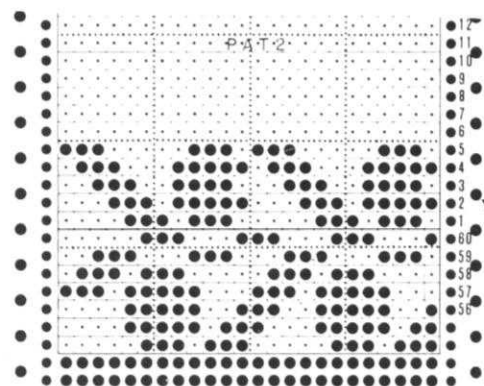

BACK and FRONT: Both sections the same. I/II

Bring 124 (136) sts. into working position then push back every 2nd needle to the out of work position. With contrast waste yarn, cast on over the remaining needles. After knitting 8 to 10 rows, change to color 1 (with color 3) and put Counter at 0. Knit Stockinette stitch to Row 40. Bring all the empty needles into working position and hang the hem. Work 16 rows Stockinette stitch with colors 1 & 3, then work the elephant design, isolating 1 or 2 in center with colors 1 & 3 together and color 2 for the design. (Always work the designs with same color set up). After Row 134 (146), work the 12 rows of Pattern 2. then work 8 rows Stockinette stitch and then the Elephant Design across. After Row 210 (222), ON EACH SIDE, bind off (or remove onto waste yarn) 30 sts. Bind off or remove onto waste yarn, the 64 sts. for neck.

HP1041

MAN'S PULLOVER

SIZE: 36/38
 YARN: Any light weight 3-ply yarn to give stitch and row gauge.
 GRAMS: - Approximately 250 grams color 1 (beige) and small amounts of the other colors.
 color 1 = Beige
 color 2 = Dark Green
 color 3 = Khaki
 color 4 = Medium Green
 color 5 = Olive
 color 6 = Moss
 color 7 = Red-Brown Angora
 color 8 = Light Green Angora
 color 9 = Beige Angora
 TENSION: 5 to 8
 GAUGE: 14 sts. 17 rows = 5 cm (2")
 NO KIT AVAILABLE.

Make this Pullover on the Electronic Machine. Send 50¢ for copy of original Drawing. If you own a Punch Card Machine, substitute Punch Cards of your choice. Norwegian Designs with K1, P1 Ribbing for the bands.

FINISHING: See General Instructions. Sew shoulder seams 16 cm (6 1/2").

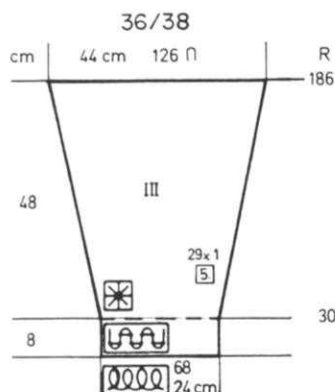

SLEEVES: III

Cast on 68 sts. with color 1 and work 30 rows Ribbing. Transfer the Ribber sts. and continue in Pattern. Work 20 rows with color 6 and 2. 45 rows color 3. 25 rows color 4. 22 rows with colors 5 and 9. 44 rows with color 1 and 5 (Pat.2). After Row 186, bind off.

BACK AND FRONT: Both sections the same.

Cast on 142 sts. with color 1 and work 30 rows Ribbing. Transfer the Ribber sts. and continue in Pattern. Work 20 rows with colors 6 and 2. 45 rows with colors 3 and 7. 25 rows with colors 4 and 8. 22 rows with colors 5 and 9. 54 rows with color 1 and 5 (Pat.2). 26 rows with color 1 (Ribbing). After Row 222, bind off loosely.

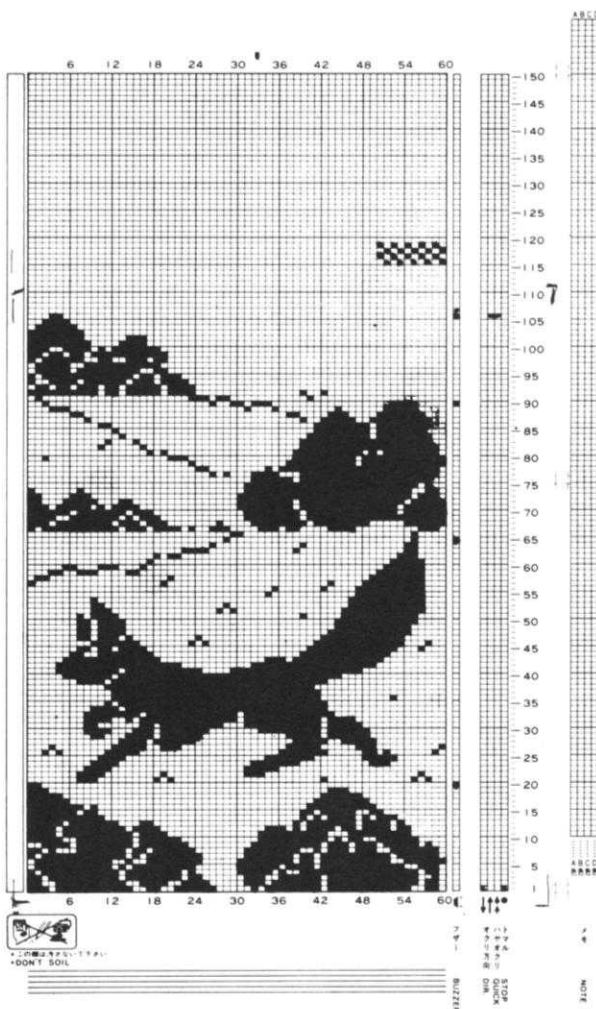
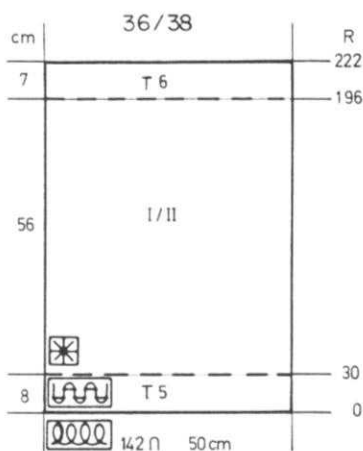

DK1042

WOMAN'S PULLOVER

SIZE: 12
 YARN: Amore or equivalent. for color 1.
 GRAMS: color 1 450
 color 2 60 -Angora or Mohair.
 color 3 20 -Angora or Mohair.
 color 4 Lurex
 NO KIT AVAILABLE.
 TENSION: 3 to 4
 GAUGE: 16 1/2 sts. 22 rows = 5 cm (2")

Stockinette stitch with a Norwegian Design. Punch your own Card. The bands are knitted over every 2nd needle for a Mock Rib.

FINISHING: See General Instructions.



NECKBAND:

Bring 120 needles into working position and push back every 2nd needle to the out of work position. Using waste yarn cast on and work the Mock Ribbing same as you did for front and back. Work 3 rows color 2, 2 rows color 4, 2 rows color 2. Bring empty needles into working position and bind off. Sew the open edge to neckline then pull out waste yarn.

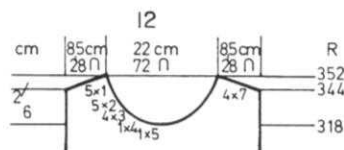
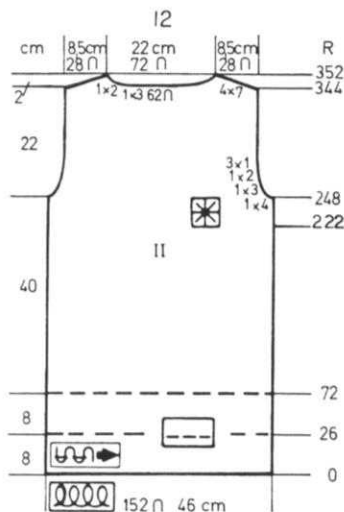

FRONT: I

Work the front the same as the back to Row 318.
Divide in the center. Put the needles on the left into holding position and complete the right side first.
*ON NECK SIDE, bind off 5 sts. 1x, 4 sts. 1x, 3 sts. 4x, 2 sts. 5x, 1 st. 5x.
After Row 344, SHAPE SHOULDER same as the back.

BACK: II

Bring 152 needles into working position then push back to the out of work position every 2nd needle.
With contrast waste yarn, cast on over the remaining needles and knit 8 to 10 rows. Change to color 1 and put Counter at 0.
Knit to Row 72. Bring all the empty needles into working position and hang the hem.
Continue in Stockinette stitch with color 1 to Row 222.
Begin Pattern. (watch for armhole).
Tree - 12 Rows with colors 1 and 3.
6 rows with colors 1 and 4.
4 rows Stockinette with color 1
Elephant - 36 rows with colors 1 and 2.
4 rows Stockinette with color 1
Tree - 12 rows with color 1 and 3.
6 rows with color 1 and 4.
BUT AT THE SAME TIME, after Row 248 SHAPE ARMHOLE: ON EACH SIDE bind off 4 sts. 1x, 3 sts. 1x, 2 sts. 1x, 1 st. 3x.
When Pattern is completed, continue in Stockinette stitch with color 1 to Row 344.
Bind off the center 62 sts., put the needles on the left into holding position and complete the right side first.
*SHAPE SHOULDER AND NECK AT THE SAME TIME.
FOR SHOULDER, bind off 7 sts. 4x and ON NECK SIDE, bind off 3 sts. 1x, 2 sts. 1x.
Bring the needles on the left into working position and complete the left half. Follow the instructions from *.

SLEEVES: III

Bring 60 needles into working position then push back every 2nd needle to the out of work position. With contrast waste yarn, cast on over the remaining needles.
Work in the Mock Ribbing same as you did for back and front to Row 60. Bring all empty needles into working position and hang the hem.
Continue in Stockinette stitch with color 1.
ON EACH SIDE, increase 1 st. every 8th row 20x.
After Row 228, SHAPE CAP AND AT THE SAME TIME, BEGIN PATTERN AFTER ROW 236.
Follow the Chart for the CAP SHAPING ON EACH SIDE, and after Row 236, work Pattern as follows:
Elephant - 36 rows with colors 1 and 2.
4 rows Stockinette with color 1
Tree - 12 rows with colors 1 and 3
6 rows with colors 1 and 4
Continue with Stockinette and knit 10 rows color 1, 3 rows color 4, 4 rows color 1, 3 rows color 4, 10 rows color 1.
After Row 324, bind off the remaining sts.

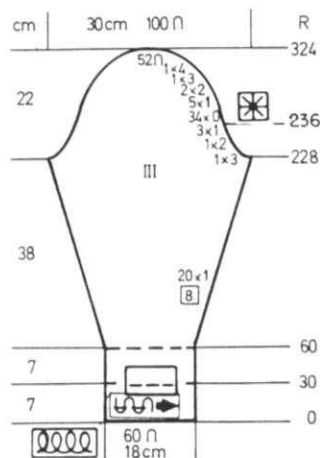
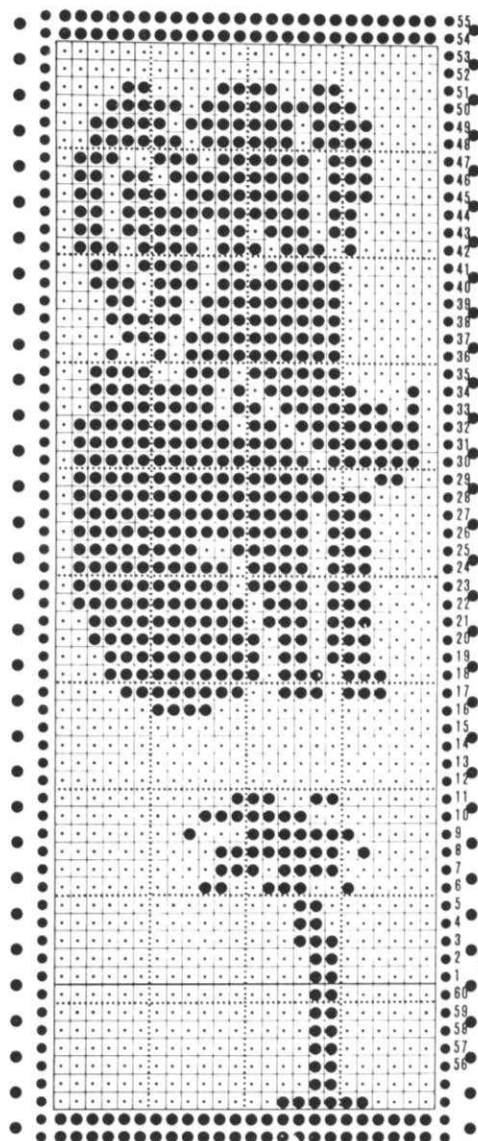

DK1043

WOMAN'S PULLOVER

SIZE: 8/10
 YARN: Any combination of yarns which will give you the 3-ply plus Lurex Stitch and Row Gauge.

GRAMS:
 color 1 200 - White
 color 2 200 - Medium Blue
 color 3 80 - Rust Lurex
 color 4 20 - Light Blue
 color 5 60 - Rust Angora
 color 6 20 - Pink

NO KIT AVAILABLE - Use left over yarns in colors of your choice. All amounts of yarn are approximate. TENSION: 6 to 9 GAUGE: 15 sts. 19 rows = 5 cm (2")

There are 7 Punch Cards used for this Pullover in Norwegian Designs. You can add a glitter thread such as Mami Rex to any part of the design (See Picture) but use your own judgement. We will give you the number of rows for each of the Designs - you chose the colors.

FINISHING: See General Instructions.

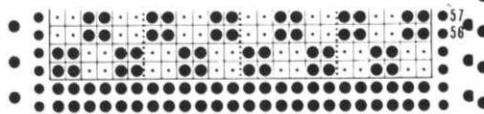

PATTERN 1

REPEAT THE PUNCH CARD THROUGH ROW 37 then punch 2 rows of holes for connecting Card.

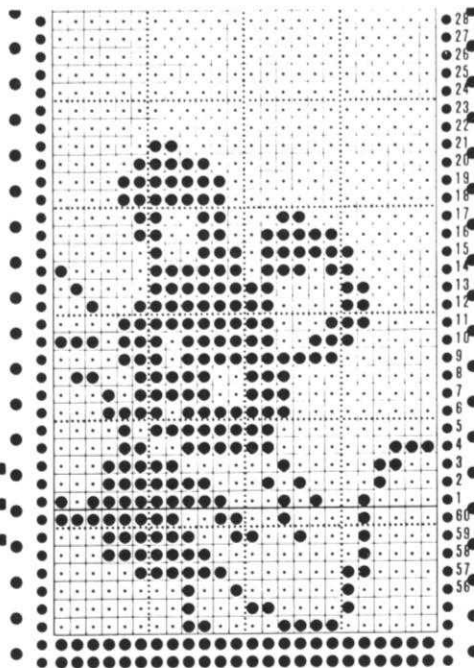

PATTERN 4

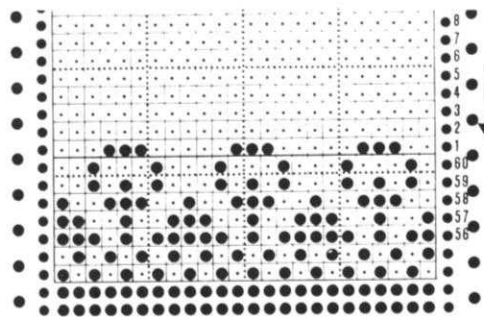

PATTERN 3

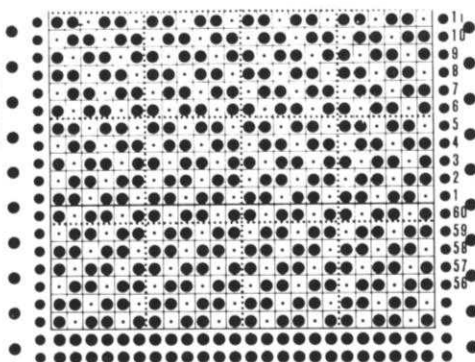

PATTERN 5

REPEAT THE PUNCH CARD THROUGH ROW 47 then punch 2 rows of holes for connecting Card.

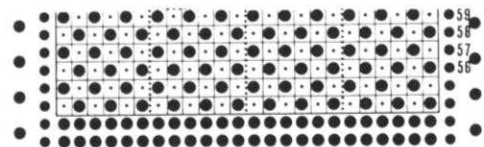

PATTERN 6

REPEAT THE PUNCH CARD THROUGH ROW 39 then punch 2 rows of holes for connecting Card.

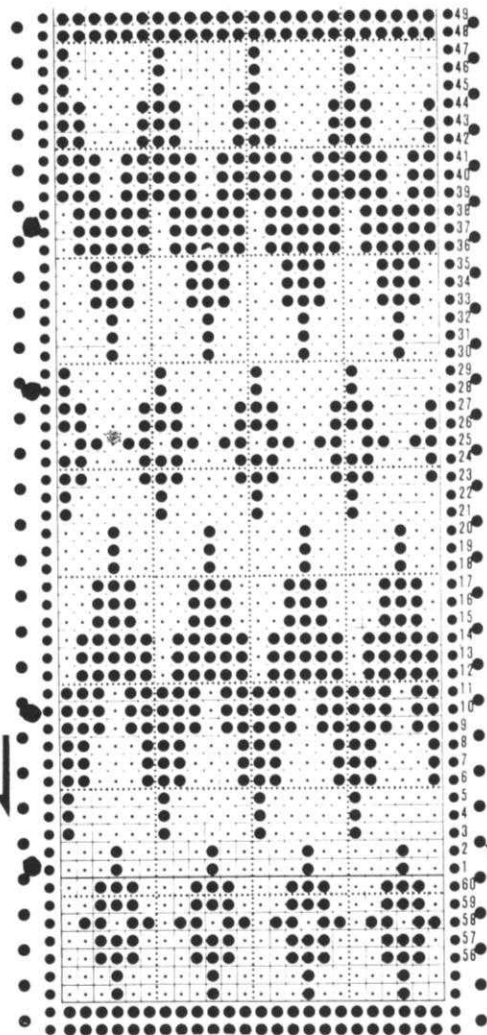

PATTERN 2

Change colors as shown along side left side of Card (large dot).

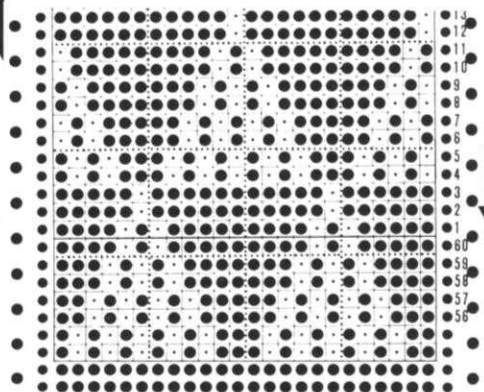

PATTERN 7

REPEAT THE PUNCH CARD THROUGH ROW 53 then punch 2 rows of holes for connecting Card.

BACK: II

Bring 140 needles into working position then push every 3rd needle back to the out of work position. With contrast waste yarn, cast on over the remaining needles. Knit 8 to 10 rows then change to color 1 (white) and put Counter at 0. Knit Stockinette stitch and Pattern as follows.

NUMBER OF ROWS

- 52 = Stock (Mock Rib) color 1.
- 2 = Hang hem then set Pattern 1.
- 28 = Pattern 1 - color 1 and 3
- 63 = Pattern 2 - (CHANGE COLORS AS MARKED ON CARD.)
- 4 = Pattern 3 - color 1 and 4) Flower
- 4 = Pattern 3 - color 1 and 6)
- 2 = Stockinette - color 1
- 28 = Pattern 4 - color 1 and 5
- 10 = Stockinette - color 1 AND BEGIN ARMHOLE SHAPING after Row 184. - Follow the bind offs on each side as shown on Chart.
- 44 = Pattern 5 - color 4 and 1
- 43 = Pattern 5 - color 1 and 5 and SHAPE SHOULDER ON EACH SIDE after Row 274 as shown on the Chart.

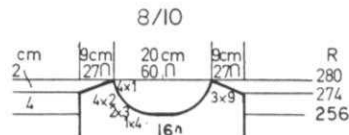
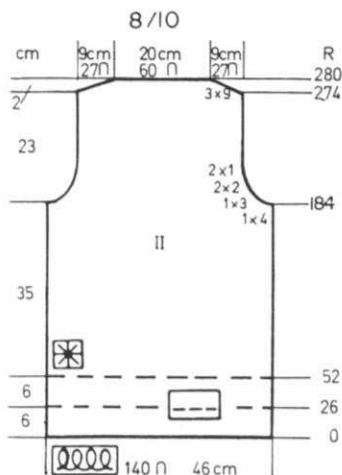

FRONT: I

Work the front the same as the back up to the Neck Shaping. After Row 256, bind off the center 16 sts. put the needles on the left into holding position and complete the right side first.

*CONTINUE IN PATTERN AS GIVEN for Back.
ON NECK SIDE, bind off 4 sts. 1x, 3 sts. 2x, 2 sts. 4x, 1 st. 4x and SHAPE SHOULDER SAME AS THE BACK after Row 274. Bring the needles on the left into working position and knit 1 row in Pattern to the left side. Turn the Row Counter back to 256 and complete the left half. Follow the instructions from *.

SLEEVES: III

Bring 60 needles into working position and push every 3rd needle back to the out of work position. Cast on over the remaining needles with waste and yarn and work the Mock Rib as you did for back and front.

NUMBER OF ROWS-SHAPE AS SHOWN ON CHART

- 52 = Mock Rib with color 1
- 2 = Hang hem and Set Pattern 1
- 28 = Pattern 1 - color 1 and 3
- 4 = Pattern 3 - color 1 and 4
- 4 = Pattern 3 - color 1 and 6
- 2 = Stockinette - color 1
- 28 = Pattern 4 - color 1 and 5
- 10 = Stockinette - color 1
- 28 = Pattern 1 (CARD ON STOP) colors 1 and 2
- 26 = Pattern 6 - color 1 and 2
- 10 = Stockinette - color 1
- 12 = Stockinette - color 3
- 10 = Stockinette - color 1
- 50 = Pattern 7 - color 5 and 1
- 8 = Stockinette - color 1
- 2 = Stockinette - color 3
- 8 = Stockinette - color 1

NECKBAND:

Bring 126 sts. into working position then push every 2nd needle back to the out of work position. Cast on for a Mock Rib same as you did for back and front. Work Stockinette stitch over every 2nd needle with color stripes of 3 rows color 1, 2 rows color 3, 10 rows color 1. Bind off or remove onto waste yarn. Sew 1 edge to inside and 1 to outside of neckline.

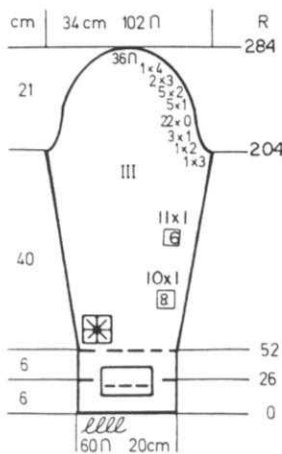

DK1044



WOMAN'S PULLOVER

- SIZES: 8/10 (12)
- YARN: Amore or equivalent for color 1, 2-ply Mohair for color 2, plus small amount Lurex.
- GRAMS: color 1 200 250, color 2 150 200
- Small amount Lurex .
- TENSION: 6 to 8
- GAUGE: 14 sts. 17 1/2 rows = 5 cm (2")
- NO KIT AVAILABLE

A Norwegian Design with bands in K1, P1 Ribbing. Punch your own Card.

FINISHING: See General Instructions.

NECK FACING:

Work 3 rows single crochet around neckline then turn to the inside and sew in place loosely.

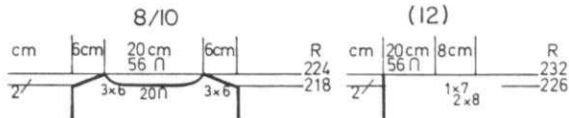

FRONT: I

Work the front the same as the back to Row 218 (226). Bind off the center 20 sts., put the needles on the left into holding position and complete the right side first. *SHAPE SHOULDER AND NECK AT THE SAME TIME. For Shoulder, bind off 6 sts. 3x (8 sts. 2x, 7 sts. 1x) FOR NECK, bind off 6 sts. 3x. Bring the needles on the left into working position, knit 1 row in Pattern to the left side, turn the Row Counter back to 218 (226) and complete the left half. Follow the instructions from *.

DK1044

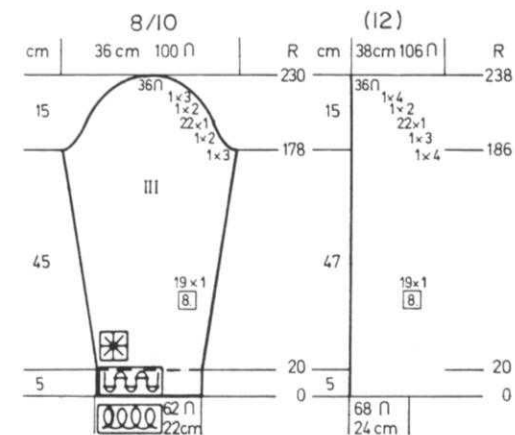

SLEEVES: III

Cast on 62 (68) sts. with color 1 and work in Ribbing same as back and front.
Continue in Pattern.
ON EACH SIDE, increase 1 st. every 8th row 19x.
After Row 178 (186), SHAPE CAP:
Please follow the bind-offs on each side as shown on the Chart for your size.
After Row 230 (238), bind off the remaining sts.

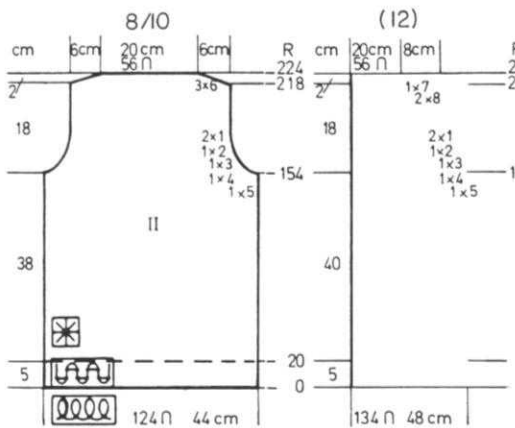

BACK: II

Cast on 124 (134) sts. with color 1 and work K1, P1 Ribbing.
Work 10 rows color 1, 2 rows Lurex, 8 rows color 1.
Transfer the Ribber sts. to main machine and continue in Pattern.
After Row 154 (162), SHAPE ARMHOLE:
ON EACH SIDE, bind off
5 sts. 1x, 4 sts. 1x, 3 sts. 1x, 2 sts. 1x, 1 st. 2x for both sizes.
After Row 218 (226) SHAPE SHOULDER:
ON EACH SIDE, bind off
6 sts. 3x.
(8 sts. 2x, 7 sts. 1x).
After Row 224 (232), bind off the remaining sts.

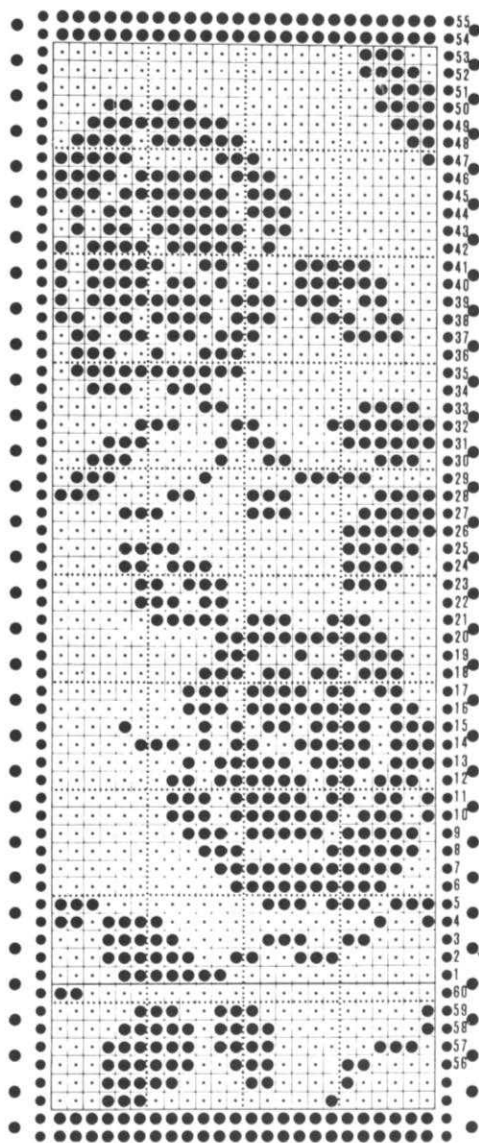

DK1045

knit
magazine



WOMAN'S PULLOVER

SIZE: 8/10
YARN: Amore
GRAMS:
color 1 450
color 2 100
color 3 50
TENSION: 4 to 6
GAUGE: 16 sts. 22 rows = 5 cm (2")

Stockinette stitch with a Norwegian Design. Punch your own Cards. Bands are Mock Ribbing (over every 2nd Needle).

FINISHING: See General Instructions. Ease in the top cap of sleeve.

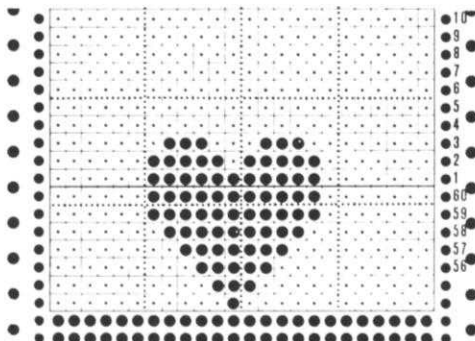

NECKBAND:

Bring 120 sts. into working position then set into Mock Ribbing same as you did before. Counter at 0 after the waste knitting.
Work 2 rows with color 1, 5 rows color 2, 4 rows color 1, 5 rows color 2, 2 rows color 1.
Bind off or remove onto waste yarn. Sew 1 edge to inside and 1 to outside of neckline.



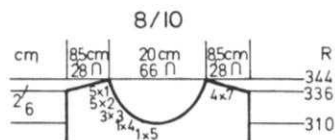

FRONT: I

Work the front the same as the back to Row 310. Bind off the center 10 sts., put the needles on the left into holding position and complete the right side first.

*ON NECK SIDE, bind off 4 sts. 1x, 3 sts. 3x, 2 sts. 5x, 1 st. 5x, AND SHAPE SHOULDER same as the back after Row 336. Bring the needles on the left into working position, knit 1 row to the left side, turn the Row Counter back to 310 and complete the left half. Follow the instructions from *.

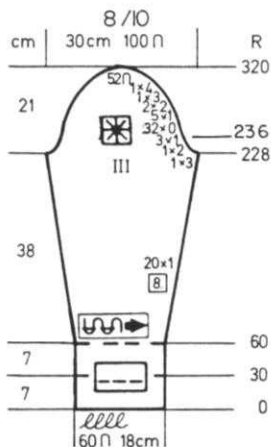

SLEEVES: III

Bring 60 needles into working position then set up into Mock Ribbing same as you did for the front and back. Cast on and work the Mock Ribbing to Row 60. Bring the empty needles into working position then hang the hem.

Continue in Stockinette stitch with color 1 and ON EACH SIDE increase 1 st. every 8th row 20x. After Row 228, SHAPE CAP: Please follow the bind-offs for the Cap Shaping ON EACH SIDE as shown on the Chart AND AT THE SAME TIME, after Row 236, work the 59 rows of Pattern 1 (Cat) with colors 1 and 2. Knit 2 rows Stockinette stitch with color 1 then work 10 rows of Pattern 2 with color 1 and 3 (Heart). Continue with color 1 and Stockinette stitch. After Row 320, bind off the remaining sts.

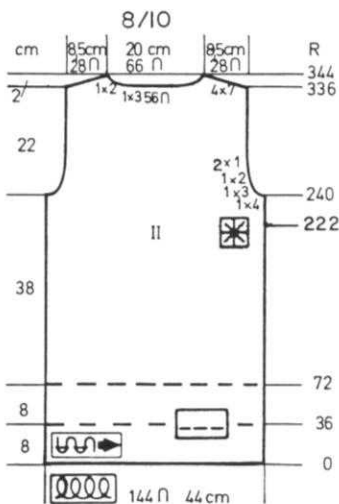

BACK: II

Bring 144 needles into working position then push back every 2nd needle to the out of work position (for a Mock Rib). With contrast waste yarn, cast on over the remaining needles. Knit 8 to 10 rows then change to color 1 and put Counter at 0. Knit 72 rows. Bring the empty needles into working position then hang the hem.

Continue in Stockinette stitch with color 1 to Row 222. Work the 10 rows of Pattern 2 (Heart) with colors 1 and 3. Work 2 rows Stockinette stitch with color 1. (Watch for Armhole Shaping) Work the 59 rows of Pattern 1 (Cat) with colors 1 and 2. Work 3 rows Stockinette stitch with color 1. Work the 10 rows of Pattern 2 with colors 1 and 3 (Heart). AT THE SAME TIME, after Row 240, SHAPE ARMHOLE: ON EACH SIDE bind off 4 sts. 1x, 3 sts. 1x, 2 sts. 1x, 1 st. 2x. After Row 336, bind off the center 56 sts., put the needles on the left into holding position and complete the right side first.

*SHAPE SHOULDER AND NECK AT THE SAME TIME. FOR SHOULDER, bind off 7 sts. 4x. FOR NECK, bind off 3 sts. 1x, 2 sts. 1x. Bring the needles on the left into working position, knit 1 row to the left side, turn the Row Counter back to 336 and complete the left half. Follow the instructions from *.

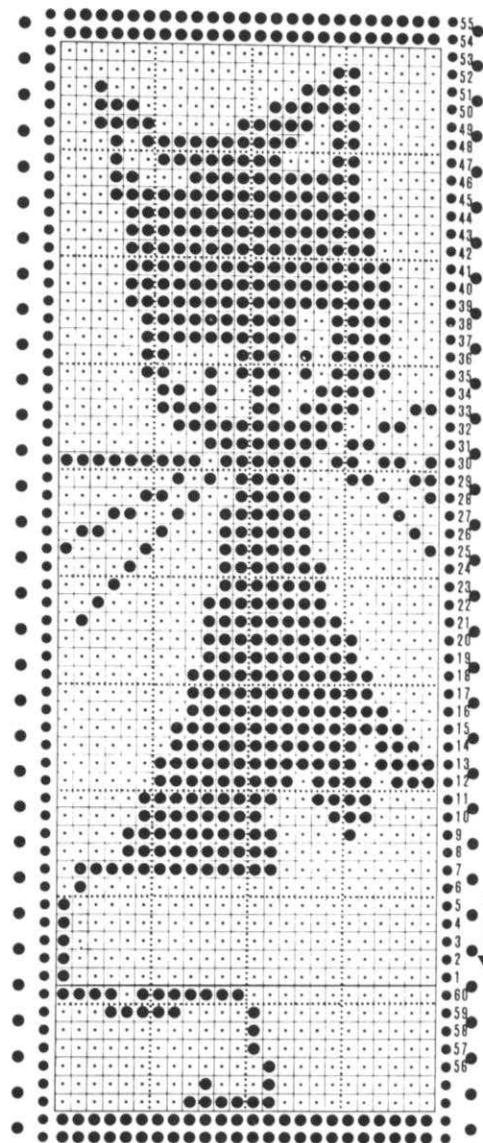

DK1046

WOMAN'S JACKET

SIZE: 10/12
 YARN: 2-ply Mohair or any yarn to give stitch and row gauge for color 1. Angora and Lurex.
 GRAMS: Approximate
 color 1 250 - White or Natural Mohair (2-ply)
 color 2 80 - Brown Angora
 color 3 100 - Rose Angora
 color 4 40 - Light Blue Angora
 Small amount Pink and Blue Angora
 NOT KIT AVAILABLE
 TENSION: 6 to 10
 GAUGE: 13 sts. 15 rows = 5cm (2")

Can be made on Punch Card and Electronic Machine. Use the Mouse Pattern from DK 1043. SET MACHINE FOR DOUBLE THE HEIGHT for Punch Card Machines. Electronic Machine owners - draw all Designs on a Mylar Sheet. Use the Mouse Design from DK 1043 and set the machine for DOUBLE the width and Height. Bands are K1, P1 Ribbing.

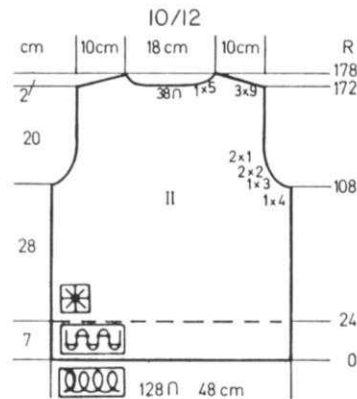

BACK: II

Cast on 128 sts. with color 1 and work 24 rows Ribbing with 10 rows color 1, 2 rows color 4, 2 rows Blue Lurex, 2 rows Pink Lurex, 4 rows color 3, 4 rows color 1.
 Transfer the Ribber sts. to main machine and work 2 rows color 1 then work 3 rows Pattern 2 with colors 1 and 4.
 Work 4 rows color 1 then work the 56 rows of Mouse Pattern with colors 1 and 2.
 Work 6 rows color 1, 8 rows of Pattern 1 with colors 1 and 3, 6 rows color 1, 5 rows Pattern 3 with colors 1 and 4.
 8 Rows color 1, then work the scalloped Pattern as shown in Picture (Draw it on your Mylar sheet) and when scallop is completed continue in Stockinette stitch with color 3. AT THE SAME TIME, please follow the SHAPINGS as shown on the Chart for the Armhole, Neck and Shoulder.

SLEEVES: III

Cast on 66 sts. with color 1 and work K1, P1 Ribbing with color stripes same as back and front.
 After Row 24, transfer the Ribber sts. to main machine and continue in Stockinette st. with color 1.
 ON EACH SIDE, increase 1 st. every 6th row 12x.
 After Row 102, Work in Pattern SAME AS FRONT AND BACK and after Row 114, SHAPE CAP: ON EACH SIDE, bind off 3 sts. 1x, 2 sts. 2x, 1 st. 20x, 2 sts. 2x, 3 sts. 1x.
 After Row 166, bind off the remaining sts.

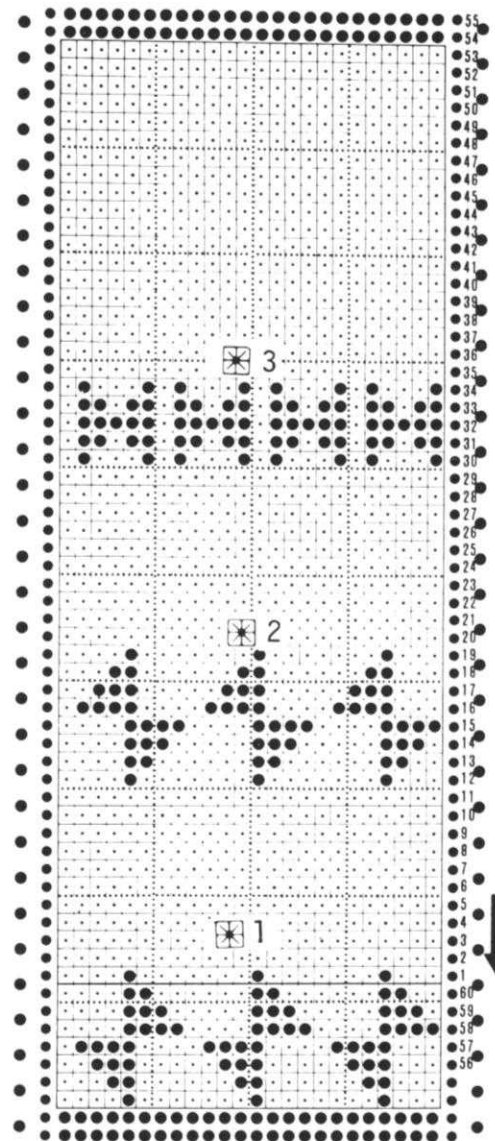

FRONT AND NECK BANDS: Make 2.

Cast on 173 sts. and work in Ribbing with color stripes of 3 rows color 1, 3 rows color 4, 2 rows color 1, 3 rows color 3, 2 rows color 1. Bind off or remove onto contrast waste yarn.

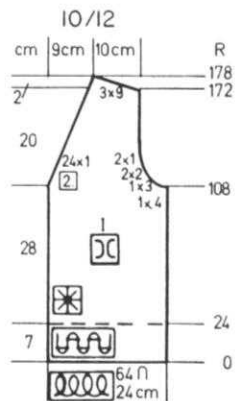

FRONT: I Make 1, reverse 1.

Cast on 64 sts. with color 1 and work in Ribbing with color stripes same as the back and front. After Row 24, transfer the Ribber sts. and continue in Pattern same as the back.
 AT THE SAME TIME, after Row 108, SHAPE ARMHOLE AND NECK: FOR AMHOLE, bind off 4 sts. 1x, 3 sts. 1x, 2 sts. 2x, 1 st. 2x AND ON NECK SIDE decrease 1 st. every 2nd row 24x. After Row 172, SHAPE SHOULDER: Bind off 9 sts. 3x.
 Make the left section with reverse shaping and be sure to reverse the Mouse.

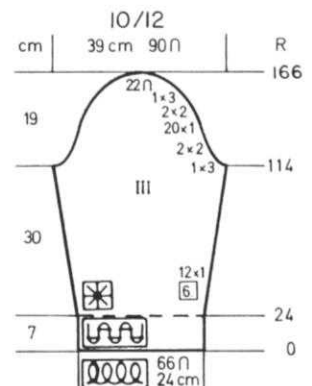

DK1047

WOMAN'S JACKET

SIZE: Medium/Large
 YARN: Any combination of yarns to give stitch and row gauge.
 GRAMS: NO KIT AVAILABLE
 color 1 200 - Dark Green Angora
 color 2 80 - Medium Green Angora
 color 3 80 - Light Green Angora
 color 4 100 - Yellow
 color 5 100 - Light Green
 color 6 Lurex - Mixed colors.
 color 7 50 - Beige
 TENSION: 6 to 9
 GAUGE: 13 sts. 15 1/2 rows = 5 cm (2")



Norwegian Designs combined with color stripes. Punch the Cards. Some of the designs will be reversed so watch for the instructions. Bands are Stockinette stitch. Follow the Chart for the Cap Shaping of sleeves.

FINISHING: See General Instructions.

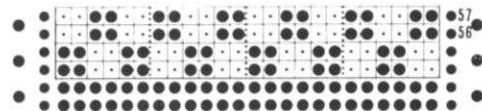

PATTERN 1 - REPEAT THE PUNCH CARD THROUGH ROW 37 then punch 2 rows of holes for connecting Card.

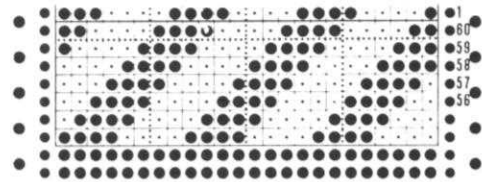

PATTERN 2 - REPEAT THE PUNCH CARD THROUGH ROW 33 then punch 2 rows of holes for connecting Card.

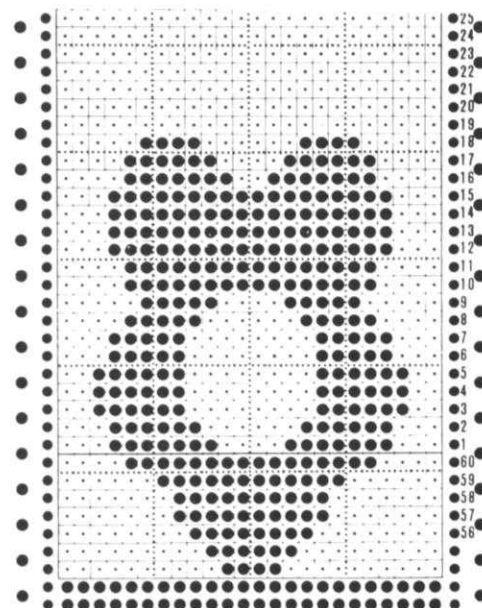

PATTERN 3

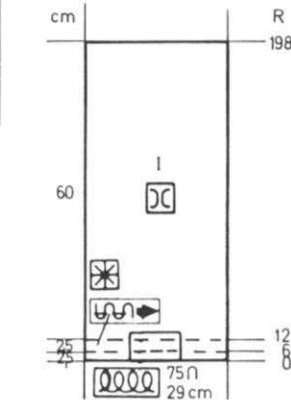

FRONT: I Make 1, reverse 1 AND BE SURE TO REVERSE CARDS FOR LEFT FRONT.

Cast on 75 sts. with color 1 and work 12 rows Stockinette stitch. Hang the hem and knit 2 rows.
 WORK IN PATTERNS same as for the back.
 After Row 198, bind off.

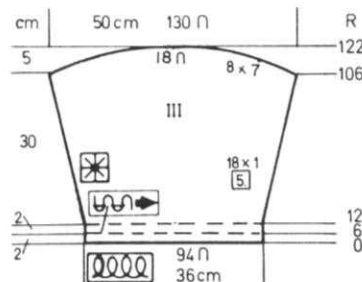

SLEEVES: III

Cast on 94 sts. with color 1 and work 12 rows Stockinette stitch. Hang the hem and knit 2 rows.
 BEGIN COLOR STRIPES AND PATTERNS AS FOLLOWS:
 Work color stripes of 2 rows EACH with colors 7, 6, 5, 3.
 BEGIN PATTERN 1. With color 3 as the MAIN COLOR, work 2 rows EACH with second color as 6, 1, 7, 4, 5, 6, 1, 7, 4, 5.
 Work color stripes - 2 rows EACH - colors 3, 5, 6, 7. 6 rows color 1
 2 rows EACH - colors 4, 7, 5, 6, 1.
 Work PATTERN 1 WITH CARD ON STOP Color 3 as MAIN COLOR and 2 rows EACH with second color as 5, 7, 4.
 Work color stripes of 2 rows EACH - colors 3, 6, 5, 7, 4, 1.
 Work PATTERN 2 with MAIN COLOR as 1 and work 2 rows EACH with second color as 7, 6, 7, 3, 4, 5, 6, 7, 3, 4.
 Work color stripes of 2 rows EACH with colors 1, 6, 3, 5, 7, 4, 3, 6.
 AT THE SAME TIME, SHAPE CAP ON EACH SIDE as shown on the Chart after Row 106.

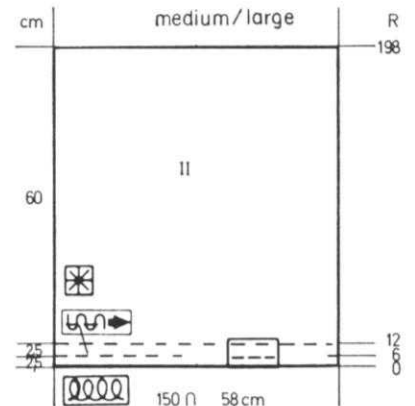

BACK: II

Cast on 150 sts. with color 1 and work 12 rows Stockinette stitch. Hang the hem, knit 2 rows and BEGIN COLOR STRIPES AND PATTERNS AS FOLLOWS:

Work color stripes - 6 rows EACH of colors 2, 3.
 2 rows EACH of colors 6, 2.
 6 rows EACH of colors 1, 2, 6.
 2 rows color 3.
 BEGIN PATTERN 1 with CARD ON STOP. Work 2 rows EACH with MAIN COLOR as 3 plus colors 5, 4, 5.
 Work color stripes of 2 rows EACH of colors 3, 6, 2. 6 rows color 1.
 2 rows EACH of colors 2, 6, 3.
 Work PATTERN 1 with MAIN COLOR AS 3 and work 2 rows EACH with 2nd colors - 5, 4, 7, 2, 1, 6, 5, 4, 7, 2, 1.
 Work color stripes of 2 rows EACH - colors 3, 6, 2, 1, 2, 6, 3.
 Work Pattern 2 WITH CARD REVERSED. Color 1 as main color and work 2 rows EACH with 2nd color as 4, 2, 7, 3, 5, 6.
 Work 2 rows color 1, then begin PATTERN 3.
 7 rows with color 1 and 4 11 rows with colors 4 and 6
 7 rows with color 1 and 4.
 Work 3 rows color 1
 Work PATTERN 2 WITH CARD REVERSED. Color 1 as MAIN COLOR and work 2 rows EACH with 2nd color as 6, 5, 3, 7, 2, 4.
 Work color stripes of 2 rows EACH of colors 1, 2, 6, 3.
 Work PATTERN 2 with main color as 3 and work 2 rows EACH with 2nd color as 4, 5, 7.
 Work color stripes of 2 rows EACH - colors 3, 6, 1, 5, 7.
 Finish with color 1 and bind off after Row 198

FRONT AND NECK BANDS: Make 2.

Cast on 158 sts. with color 1 and work 20 rows Stockinette st. Bind off or remove onto waste yarn. Sew 1 edge to inside and 1 to outside of fronts and neck.

DK1048



WOMAN'S JACKET

SIZE Medium/Large
 YARN: 4-ply Knitting Worsted weight to be knitted over every 2nd needle.
 GRAMS: Approximate
 color 1 250 - Rust
 color 2 150 - Green
 color 3 100 - Camel
 color 4 100 - Blue
 color 5 100 - Beige
 TENSION: 10 OVER EVERY 2ND NEEDLE (EVERY 4th NEEDLE ON BOTH KNITTER AND RIBBER FOR THE BANDS).
 GAUGE: 10 1/2 sts. 14 1/2 rows = 5 cm (2"). NO KIT AVAILABLE.

An Intarsia Design with bands in K1, P1 Ribbing.

FINISHING: See General Instructions.

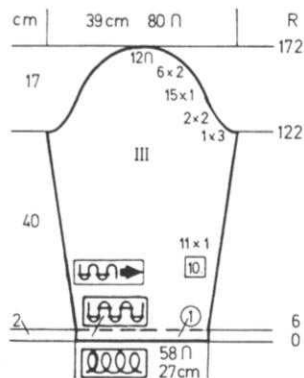

SLEEVES: III

Cast on 58 sts. with color 1 and work the Ribbing same as back and front.
 Continue in Stockinette stitch with color 1.
 ON EACH SIDE, increase 1 st. every 10th row 11x.
 After Row 122, SHAPE CAP:
 ON EACH SIDE, bind off.
 3 sts. 1x, 2 sts. 2x, 1 st. 15x,
 2 sts. 6x. After Row 172, bind off the remaining sts.

NECK AND FRONT BANDS:

Pick up the sts. down front to the solid color section and work 5 rows Ribbing. Bind off. Repeat for other side.
 Pick up the sts. around neck (from center back) to front edge and work 10 rows ribbing. Bind off. REPEAT for other side.
 Weave seams together.

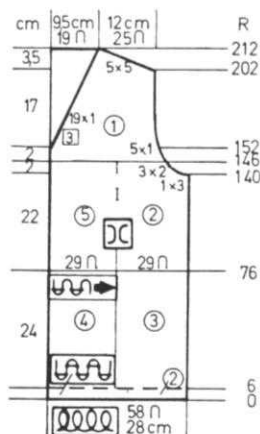

FRONT: I Make 1, reverse 1.

Cast on 58 sts. with color 2 and work 6 rows ribbing same as the back.
 Continue in the Intarsia Design with 29 sts. in color 3 and 29 sts. with color 4.
 Knit 70 rows.
 After Row 76, 29 sts. in color 2, 29 sts. in color 5.
 After Row 140, SHAPE ARMHOLE same as the back and change to color 1 after Row 146.
 After Row 152, ON NECK SIDE, decrease 1 st. every 3rd row 19x.
 After Row 202, SHAPE SHOULDER same as the back.

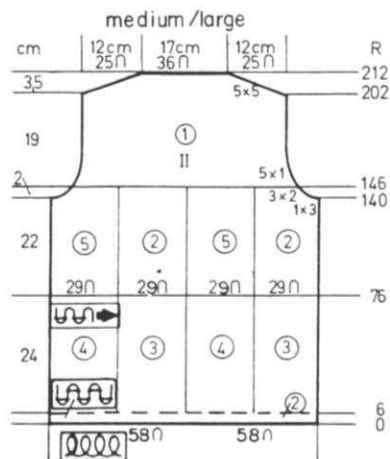

BACK: II

NOTE: Because the Jacket is knitted over EVERY 2nd NEEDLE, the back section must be made in 2 pieces up to row 146. When 2nd section is completed, you can hang the two sections together to knit the upper part. All bands are K1, P1 Ribbing and you will use every 4th needle on the main machine and every 4th on the Ribber.

Cast on 58 sts. with color 2 and work 6 rows Ribbing (See note above).
 Continue in the INTARSIA DESIGN. The first 29 sts. on the right in color 3, the next 28 plus 1 st. for seam) in color 4.
 Knit 70 rows. Be sure to twist the yarns when changing color to prevent a hole.
 After Row 76, the first 29 sts. in color 2, the next 29 in color 5.
 Knit 70 rows BUT AT THE SAME TIME, after Row 140, ON THE RIGHT, SHAPE ARMHOLE: Bind off 3 sts. 1x, 2 sts. 3x.
 After Row 146, remove the sts. onto contrast waste yarn.
 Work the 2nd half in the same way, casting on the 58 sts. then follow the CHART for the color changes and after Row 146, SHAPE THE ARMHOLE on the LEFT SIDE.
 Hang the sts. held on waste yarn back onto the machine, making sure center backs match. Leave the center seam sts. on a strand of yarn (to seam later). 96 sts. Work with color 1.
 CONTINUE TO SHAPE ARMHOLE: ON EACH SIDE, bind off 1 st. 5x.
 After Row 202, SHAPE SHOULDER: ON EACH SIDE, bind off 5 sts. 5x.
 After Row 212, bind off the remaining sts. or remove onto contrast waste yarn.

DK1049



GIRL'S PULLOVER

SIZE: 7/8
 YARN: Sport Weight
 GRAMS: Approximate
 color 1 200
 color 2 100
 NO KIT AVAILABLE
 TENSION: 9
 GAUGE: 13 1/2 sts. 20 rows = 5 cm
 (2")

A Norwegian Design and Stockinette stitch. Made on the Electronic machine and knitted sideways. Send 50¢ for copy of original drawing. Bands are K1, P1 Ribbing.

FINISHING: See General Instructions.

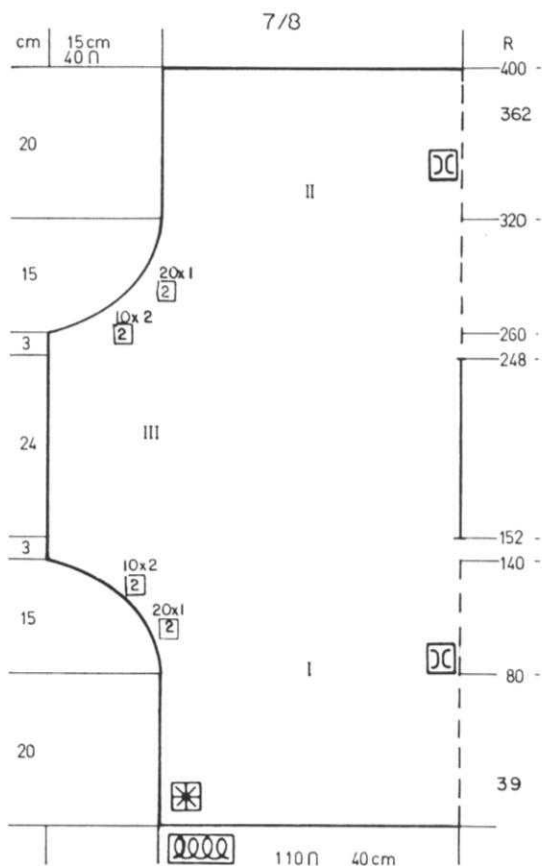
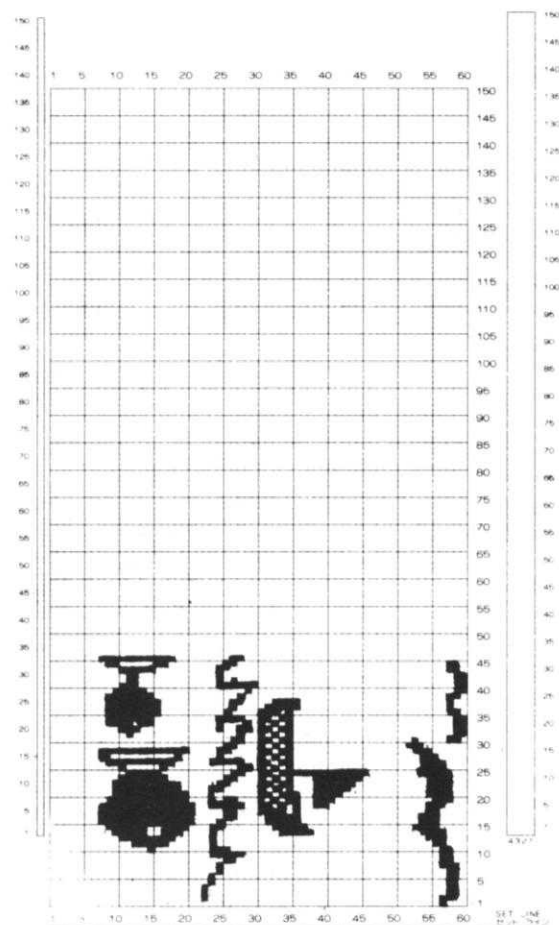

BACK and FRONT I/II Make 1, reverse 1.

With contrast waste yarn, cast on 110 sts. After knitting 8 to 10 rows, change to color 1 of garment yarn and put Counter at 0. Knit in Stockinette stitch to Row 39, then set Pattern on next row and work the 46 rows of Pattern 7x BUT AT THE SAME TIME, after Row 80, SHAPE UNDERARM: Increase 1 st. every 2nd row 20x then 2 sts. every 2nd row 10x. After Row 152, mark the neck side with a bit of waste yarn for neck opening. Mark Row 248 in the same way. After Row 260, SHAPE UNDERARM: Bind off 2 sts. every 2nd row 10x, then decrease 1 st. every 2nd row 20x. After Row 362, continue in Stockinette stitch with color 1 to Row 400 then remove the remaining sts. onto contrast waste yarn.

SLEEVE BANDS: Make 2.

Cast on 60 sts. with color 1 and work 24 rows K1, P1 Ribbing. Transfer the ribber sts. to main machine, then hang the open sts. of the sleeve, doubling the sts. as needed. Bind off.

NECKBAND:

Cast on 134 sts. with color 1 and work 24 rows K1, P1 Ribbing. Transfer the ribber sts. to main machine, hang half the neck to half the sts. Bind them off together. Hang the 2nd half and bind off.

WAIST BAND: Make 2.

Cast on 100 sts. with color 1 and work 50 rows K1, P1 Ribbing. Transfer the ribber sts. to main machine, pick up the sts. of waist, doubling the sts. as needed. Bind off together.

KK1050

CHILD'S PULLOVER

SIZES: 4/6 (8)

YARN: Sport weight

GRAMS: - Approximate

color 1 150 200

color 2 50 50

Small amounts of green, yellow, and red.

TENSION: 8 or 9

GAUGE: 13 1/2 sts. 17 rows = 5 cm

NO KIT AVAILABLE (2")

Stockinette stitch with color stripes and a Norwegian Design. Punch your own Card. Bands are MOCK Ribbing over every 2nd needle.

FINISHING: See General Instructions:

Turn 6 rows to the inside of neckline and sew in place.

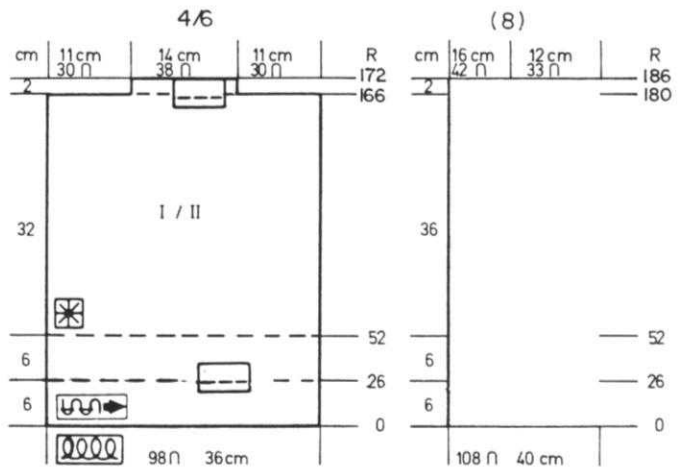

FRONT & BAND: 1/II Both sections the same.

Bring 98 (108) needles into working position, then push back every 2nd needle to the out of work position. With contrast waste yarn, cast on over the remainign needles in work. After knitting 6 to 8 rows, change to white and put Counter at 0. Knit to Row 52. Bring all empty needles into working position then hang the hem.

Work in color stripes and Pattern as follows:

4 rows white,

20 rows Norwegian Design with white and green.

6 (8) rows white, 4 (6) rows yellow,

4 (6) rows white, 4 (6) rows red,

4 rows white, 22 (28) rows blue,

8 rows white, 4 rows blue,

5 rows white, 8 rows green,

8 rows white, 4 rows yellow,

4 rows white, 6 rows red.

After Row 166 (180), ON EACH SIDE, bind off 30 (33) sts. for shoulder.

With red, knit to Row 172 (186) over the remaining sts. then bind off loosely.

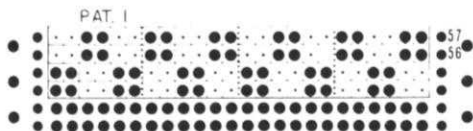

REPEAT THE PUNCH CARD THROUGH ROW 37 then punch 2 rows of holes for connecting Card.

SLEEVES: III

Bring 44 (48) needles into working position and push back every 2nd needle to the out of work position.

Work the Mock Ribbing same as you did for front and back to row 40. Hang the hem.

ON EACH SIDE, increase 1 st. every 4th row 18x BUT AT THE SAME TIME, work the color stripes and Pattern as follows:

FOR SLEEVE NO. 1:

4 (6) rows white
7 (8) rows Norwegian Design with white and red,

3 (4) rows white, 5 (6) rows yellow,

7 (8) rows white, 13 (15) rows green,

4 rows white, 6 rows blue,

6 rows white, 19 rows red.

FOR SLEEVE NO. 2 work stripes and pattern as follows:

5 (6) rows white,

7 (8) rows Norwegian Design with white and blue,

4 (6) rows white,

8 (10) rows red, 6 (8) rows white,

10 rows green, 4 rows white,

30 rows blue.

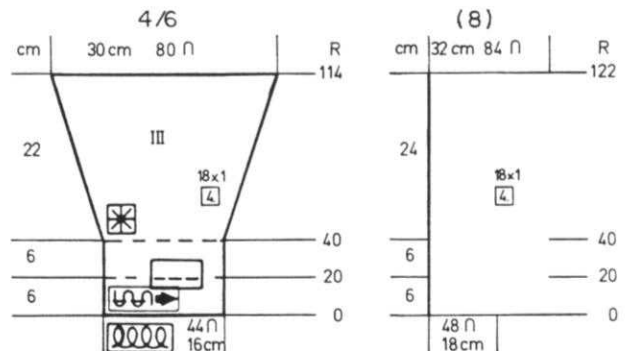

DK1051



WOMAN'S PULLOVER

SIZES: 8/10 (12)
YARN: Vienna

GRAMS:
color 1 250 250
color 2 100 100
color 3 50 50
color 4 50 50

TENSION: 4 ro 6

GAUGE: 16 sts. 21 rows = 5 cm (2")

An INTARSIA DESIGN with Stockinette stitch. Follow the Chart for the changes in color.
Reverse the design on the front section. Bands are K2, P2 Ribbing.

FINISHING: See General Instructions.

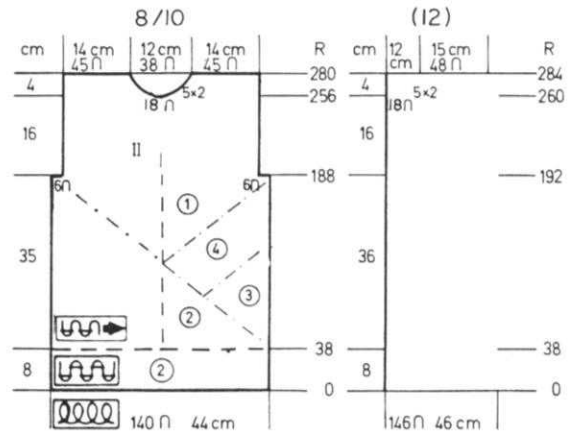

BACK: II

Cast on 140 (146) sts. with color 2 and work 38 rows K2, P2 Ribbing. Transfer the ribber sts. to main machine and continue in the INTARSIA Design.

Begin with 2 sts. in color 3 on the Right, the rest in color 2. ON EVERY ROW, increase 1 st. for color 3 and decrease 1 st. for color 2 for 46 rows after Band. Now add 1 st. color 4 (after color 3) the rest in color 2 and move color 3 over to the right (decrease) and increase 1 st. EACH SIDE for color 4 ON EVERY ROW for 46 rows. Add 1 st. in the middle in color 1 then ON EVERY ROW decrease 1 st. color 4 and INCREASE 1 st. color 1 ON EACH SIDE. When all needles are in color 1, after Row 188 (192) ON EACH SIDE bind off 6 sts. for armhole and continue in color 1.

After Row 256 (260), bind off the center 18 sts., put the needles on the left into holding position and complete the right side first. *ON NECK SIDE, bind off 2 sts. 5x. After Row 280 (284), bind off the remaining sts. Bring the needles on the left into working position, knit 1 row to the left side, turn the Row Counter back to 256 (260) and complete the left half. Follow the instructions from *.

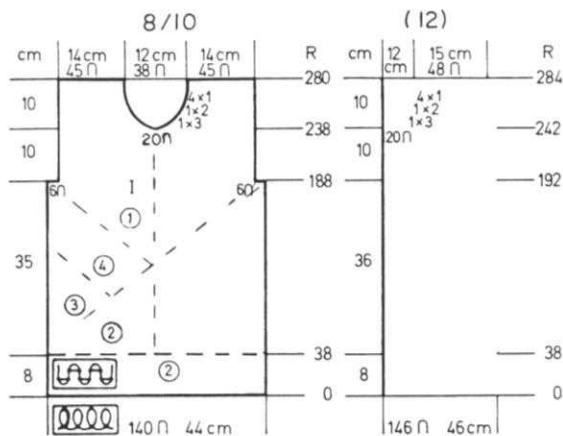

FRONT: I

Work the front the same as the back with the DESIGN on the LEFT SIDE. Have the Carriage or Slide on the LEFT and put Counter at 38 after the Ribbing is transferred. After Row 188 (192), SHAPE ARMHOLE same as the back then knit to row 238 (242). Bind off the center 20 sts., put the needles on the left into holding position and complete the LEFT side first. *ON NECK SIDE, bind off 3 sts. 1x, 2 sts. 1x, 1 st. 4x. After Row 280 (284), bind off the remaining sts. Bring the needles on right into working position, knit 1 row to the right side, turn the Row Counter back to 238 (242) and complete the right half. Follow the instructions from *.

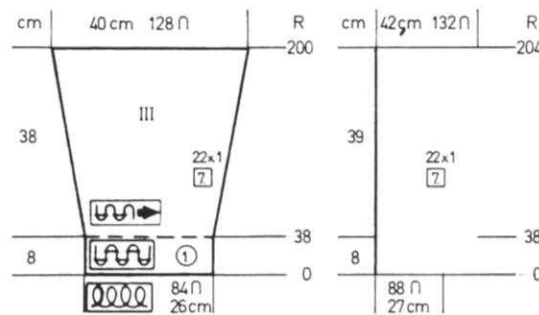

SLEEVES: III

Cast on 84 (88) sts. with color 1 and work 38 rows K2, P2 Ribbing. Transfer the ribber sts. to main machine and continue in Stockinette stitch. ON EACH SIDE, increase 1 st. every 7th row 22x. After Row 200 (204), bind off the remaining sts.

NECKBAND:

Cast on 166 sts. with color 1 and work 14 rows Ribbing. Bind off or remove onto contrast waste yarn.

KK1052

CHILD'S PULLOVER

SIZES: 8/10 (12)
 YARN: Sport Weight
 GRAMS: Approximate
 color 1 350 350
 color 2 50 50
 color 3 50 50
 TENSION: 6 to 8
 GAUGE: 13 1/2 sts. 17 1/2 rows =
 5 cm (2")
 NO KIT AVAILABLE.

An INTARSIA Design with 3 colors.
 The bands are K1, P1 Ribbing.

FINISHING: See General Instructions.



KK 1052

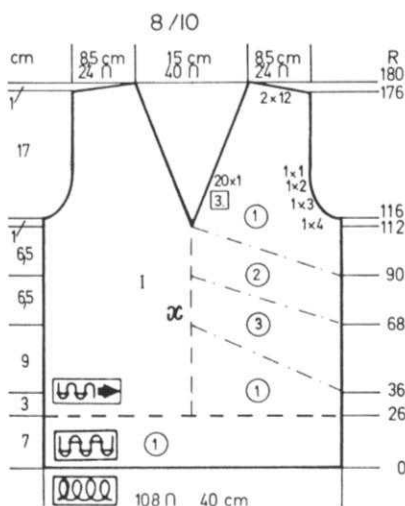

FRONT: I

Work the front the same as the back to Row 116 (120).

Divide in the center and put the needles on the left into holding position and complete the right side first.

*SHAPE ARMHOLE same as the back and AT THE SAME TIME, ON NECK SIDE, decrease 1 st. every 3rd row 20x.

After Row 176 (180) SHAPE SHOULDER same as the back.

Bring the needles on the left into working position, knit 1 row to the left side, turn the Row Counter back to 116 (120) and complete the left half. Follow the instructions from *.

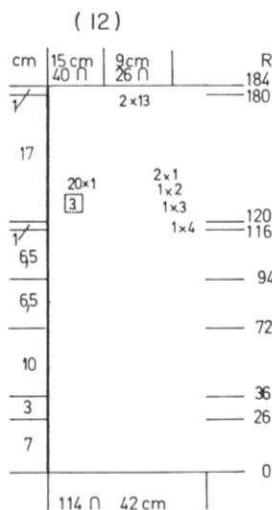

BACK: II

Cast on 108 (114) sts. with color 1 and work 26 rows Ribbing. Continue in Stockinette stitch to Row 36 then begin the INTARSIA DESIGN.

You will need 3 separate balls of yarn. Begin with 3 sts. on the right in color 3 and 102 sts. in color 1, then the last 3 sts. in color 3.

ON EVERY 2nd row, ON EACH SIDE increase 3 more sts. for color 3 Continue to follow the Chart for color changes (see Picture), increasing or decreasing 3 sts. at a time ON EACH SIDE.

End with color 1 over all sts. After Row 116 (120) SHAPE

ARMHOLE: ON EACH SIDE, bind off 4 sts. 1x, 3 sts. 1x, 2 sts. 1x, 1 st. 1x.

(4 sts. 1x, 3 sts. 1x, 2 sts. 1x, 1 st. 2x).

After Row 176 (180) bind off the center 30 sts., put the needles on the left into holding position and complete the right side first.

*SHAPE SHOULDER AND NECK AT THE SAME TIME.

FOR SHOULDER, bind off

12 sts. 2x.

(13 sts. 2x).

FOR NECK, bind off 5 sts. 1x for both sizes.

Bring the needles on the left into working position, knit 1 row to the left side, turn the Row Counter

back to 176 (180) and complete the left half. Follow the instructions from *.

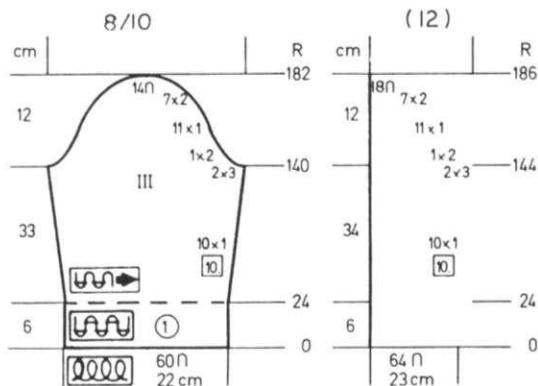

SLEEVES: III

Cast on 60 (64) sts. with color 1 and work 24 rows Ribbing. Continue in Stockinette stitch. ON EACH SIDE, increase 1 st. every 10th row 10x.

After Row 140 (144) SHAPE CAP: ON EACH SIDE, bind off 3 sts. 2x, 2 sts. 1x, 1 st. 11x, 2 sts. 7x.

After Row 182 (186), bind off the remaining sts.

NECKBAND:

Cast on 133 sts. with color 1 and work K1, P1 Ribbing. ON EACH SIDE, increase 2 sts. every 2nd row 3x. Bind off or remove onto contrast waste yarn.

HP1053

MAN'S SLEEVELESS PULLOVER

SIZES: 36/38 (40/42)
 YARN: Sport Weight
 GRAMS: Approximate
 color 1 250 300
 color 2 150 150
 color 3 150 150
 TENSION: 6 to 8
 GAUGE: 11 sts. 14 1/2 rows = 5cm
 (2")

NO KIT AVAILABLE

A NORWEGIAN DESIGN. Punch your own Card. Bands are K2, P2 Ribbing.

FINISHING: See General Instructions.

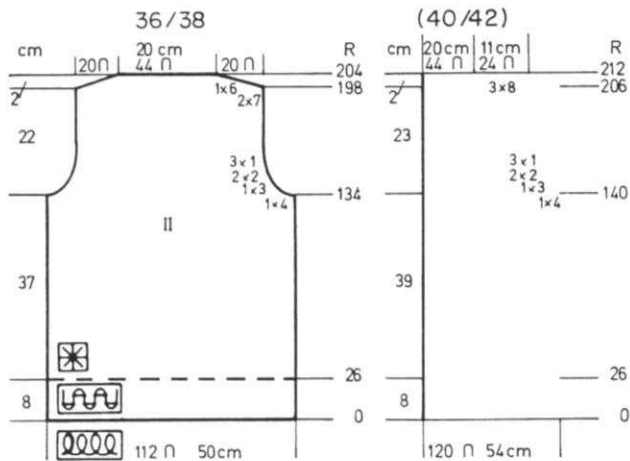

BACK: II

Cast on 112 (120) sts. with color 1 and work 26 rows K2, P2 Ribbing. Transfer the Ribber sts. to main machine and put in Punch Card. Begin Pattern.
 4 rows color 2, 6 rows color 2 and 3,
 4 rows color 2, 4 rows color 3, 13 rows color 3 and 1,
 4 rows color 3, 4 rows color 1, 10 rows color 1 and 2,
 4 rows color 1.
 REPEAT THE PATTERN THROUGHOUT.
 After Row 134 (140) SHAPE ARMHOLE: ON EACH SIDE, bind off 4 sts. 1x, 3 sts. 1x, 2 sts. 2x, 1 st. 3x for both sizes.
 After Row 198 (206) SHAPE SHOULDER: ON EACH SIDE, bind off 7 sts. 2x, 6 sts. 1x. (8 sts. 3x).
 After Row 204 (212), bind off the remaining sts. or remove them onto contrast waste yarn.

NECKBAND:

Cast on 187 sts. with color 1 and work in Ribbing same as front and back.
 ON EACH SIDE, decrease 1 st. EVERY ROW. After Row 10, bind off or remove onto waste yarn.

ARBANDS: Make 2.

Cast on 148 sts. and work the 10 rows of Ribbing same as Neckband.

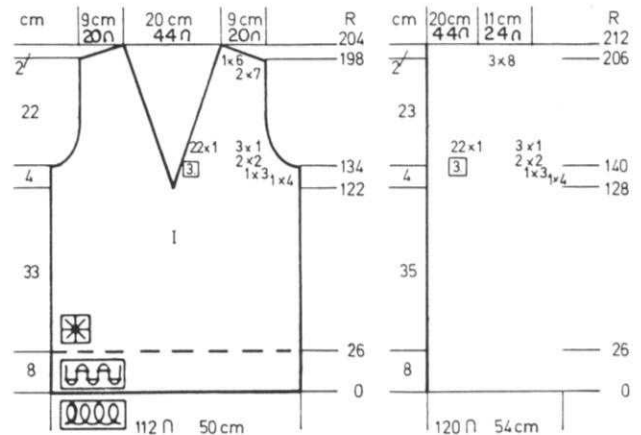
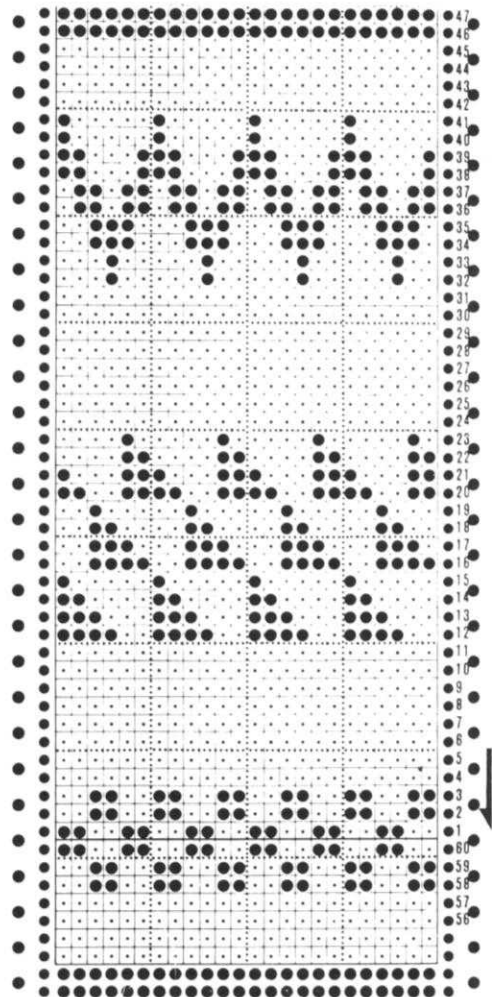

FRONT: I

Work the front the same as the back to Row 122 (128). Divide in the center. Put half the needles on the left into holding position and complete the right side first. MARK ROW ON CARD. *ON NECK SIDE, decrease 1 st. every 3rd row 22x AND AT THE SAME TIME, after Row 134 (140), SHAPE ARMHOLE same as the back.
 After Row 198 (206), SHAPE SHOULDER same as the back.
 Bring the needles on the left into working position, Set Card Row and knit in Pattern. Complete the left half. (Row Counter at 122 (128). Follow the Instructions from *.



KNITTING NEWS

PRACTICAL KNITTING HINTS

KNITTING KNITKING MAGAZINE PATTERNS ON YOUR JUMBO AND BULKY MACHINES.

It is possible to knit some of the BASIC SHAPES from KNITTING MAGAZINE Patterns on your Bulky machines. You cannot use the Pattern Designs as given, but you can make up your own designs. If you will remember to use HALF the number of stitches and HALF the number of rows shown in a Pattern, most of the time you should have no problems. You do however have to shape the sections in the same way. If an armhole bind off is 8 sts., you should bind off 4. If the total armhole bind offs are 16 sts. on each side, you should make your total bind-offs 8 on each side... etc., etc. The neck and shoulder shapings should be worked in the same manner - half the number of stitches shown for the neck bind-offs and of course half the number of stitches shown for the shoulder shaping. It may seem complicated to you at first, but try a simple pattern and see how it works out. You can also check this out with your Converta Tape to be sure that the yarn you want to use on your bulky machine is close enough to the stitch and row gauge divided IN HALF when you make up a sample swatch. If it is not, try changing the tension and make another sample and check again. You might need to make several sample swatches before you find the correct tension which will give you the stitch and row gauge you need.

DISCOUNTED YARN KITS FOR THIS ISSUE

The Yarn Kits for this issue of KNITTING MAGAZINE are available at special discounts to our subscribers and the prices are only good until the next issue of the magazine. Be sure to check the colors available listed at the end of this NEWS-LETTER and make certain to give alternate colors.

KK 1034 - Yarn: Amore
SIZES: 4/5
Regular Price \$16.73
Sale Price 13.38
Shipping costs 1.85

KK 1035 - Yarn: Amore
SIZES: 4/5
Regular Price \$16.73
Sale Price 13.38
Shipping costs 1.85

KK 1036 - Yarn: Amore
SIZES: 4/5
Regular Price \$19.12
Sale Price 15.30
Shipping costs 1.85

KK 1037 - Yarn: Amore or equivalent. (10 colors)
SIZES: 10/12 (14)
NO KIT AVAILABLE.

KK 1038 - Yarn: Amore
SIZES: 8/10 (12)
Regular Price \$21.51 \$21.51
Sale Price 17.21 17.21
Shipping costs 1.85 1.85

KK 1039 - Yarn: 2-ply Mohair, Amore or equivalent, Lurex.
SIZES: 4/6 (8)
NO KIT AVAILABLE.

KK 1040A - Yarn: Amore
SIZES: 8/10 (12)
Regular Price \$16.73 \$16.73
Sale Price 13.38 13.38
Shipping costs 1.85 1.85

KK 1040B - Yarn: Amore
SIZES: 8/10 (12)
Regular Price \$18.09 \$18.09
Sale Price 14.47 14.47
Shipping costs 1.85 1.85

HP 1041 - Yarn: 9 colors of any yarn to give stitch and row gauge.
SIZES: 36/38
NO KIT AVAILABLE.

DK 1042 - Yarn: Amore or equivalent, plus Angora or 2-ply Mohair and Lurex.
SIZES: 10/12
NO KIT AVAILABLE.

DK 1043 - Yarn: 6 colors of any yarn to give stitch and row Gauge.
SIZES: 8/10
NO KIT AVAILABLE.

DK 1044 - Yarn: Amore or equivalent plus 2-ply Mohair for color 2.
SIZES: 8/10 (12)
NO KIT AVAILABLE.

DK 1045 - Yarn: Amore
SIZES: 8/10
Regular Price \$28.68
Sale Price 22.94
Shipping costs 1.85

DK 1046 - Yarn: 2-ply Mohair and Angora
SIZES: 10/12
NO KIT AVAILABLE.

DK 1047 - Yarn: Sport weight - 7 colors.
SIZE: Medium/Large
NO KIT AVAILABLE.

DK 1048 - Yarn: Knitting worsted weight
SIZE: Medium/Large
NO KIT AVAILABLE.

KK 1049 - Yarn: Sport weight
SIZES: 7/8
NO KIT AVAILABLE.

KK 1050 - Yarn: Sport weight
SIZES: 4/6 (8)
NO KIT AVAILABLE.

KK 1051 - Yarn: Vienna
SIZES: 8/10 (12)
Regular Price \$24.30 \$24.30
Sale Price 19.44 19.44
Shipping costs 1.85 1.85

KK 1052 - Yarn: Sport weight
SIZES: 8/10 (12)
NO KIT AVAILABLE.

HP 1053 - Yarn: Sport weight
SIZES: 36/38 (40/42)
NO KIT AVAILABLE.

CHOOSE YOUR YARN KITS FROM THE FOLLOWING COLORS.

AMORE... Hot Pink, Black, Yellow, Navy, Medium Blue, Rose Tweed, Turquoise, Dark Grey, Red, Beige, Rust, Lilac Mist, Brown, off White, Coral, Jade Green, Light Pink.

VIENNA... Beige, Gold, Brown, Peach, Plum, Yellow, Medium Blue, Coral, Dark Turquoise, Aqua, Navy.

NEW, DEMONSTRATORS AND TRADED MACHINES AT GIVE AWAY PRICES...

Nobody can beat our prices, so if you want a second machine, place your order as fast as possible... Maybe you have a friend who cannot afford a brand new machine... If so, please tell her about our low, low prices... and if you want a machine not listed below, let us know... We have too many to list them all.

<u>SINGLE BED</u>		<u>CONDITION</u>	<u>LIST PRICE</u>	<u>SALE PRICE</u>
KNITKING	AM3 - Cam operated with Ribber	Excellent	\$549.00	\$199.00
	COMPUKNIT KH 910 Electronic- Demonstrator	Like New	949.95	699.95
	KH 840 with Lacemaker - Demonstrator	Like New	569.95	399.95
	KH 830 with Lacemaker	Excellent	499.95	299.95
	KH 120 - Fine needle Knitter with 258 needles and Lacemaker	Excellent	429.95	275.00
BROTHER	KH 820 with Lacemaker and Ribber	Excellent	449.95	249.95
	KH 820 with Lacemaker	Good		199.95
	KH 800 with Lacemaker	Good	349.95	100.00
	KH 588 with Lacemaker	Excellent		125.00
	KH 552 with Lacemaker - 8 Buttons	Good		75.00
	KH 551	Good		50.00
JUMBO	CN9-N Heavy Yarn Knitter	Very Good	299.95	99.95
STUDIO	326 Punch Card machine with Ribber	Like New		299.00
	322 Punch Card machine with Ribber	Like New		250.00
	321 Punch Card machine with Ribber	Like New		250.00
TOYOTA	KS 901 Punch Card machine with Lacemaker and Ribber	Like New		549.00
	KS 787 Punch Card machine with Lacemaker, Knit Tracer and Ribber	Like New		550.00
	KS 787 Punch Card machine with Lacemaker	Excellent		250.00
GENIE	710 with Lacemaker - Demonstrator	Like New	289.50	199.50
EMPISAL	Knitmaster 305	Excellent		95.00
<u>DEMONSTRATOR BABY LOCK MACHINES</u>				
	605 - Cut, Sew, Overlock - Demonstrator	Like New	429.00	250.00
	606 - BABY BLINDSTITCH - Demonstrator	Like New	599.00	325.00

MACHINE KNITTING BOOKS

By Regine Faust



FASHION KNIT \$25.95 consists of 267 pages, graphs, photographs and instructions. It gives the whole Fashion Knit Course Outline as taught at Sheridan College, through well-developed exercises. It is a perfect guide to everyone who wants to learn more than just the basic steps about machine knitting.



TUCK KNITTING \$22.95 consists of 208 pages. Over 100 full page photographs of Tuck Designs with matching graphs or punch cards and instructional hints. Tuck patterns have become so popular in Fashion or Sportswear Knits. This book opens a whole new era in Knitting.

ALL THREE FOR \$65.95



INDIAN DESIGNS \$25.95 has approximately 200 pages with American Indian designs and motifs adapted to knitting. It has full page photographs and matching punch cards which can be used as graphs for hand-knitting as well. It contains chapters of instructions and special hints for Fair Isle or knit-in techniques, repeating designs and single motifs.

Shipping costs \$1.75 each or all 3 for \$2.50

Order from your dealer or direct from KNITKING
1128 Crenshaw Blvd., Los Angeles, CA 90019

KK 1052



KK 1038

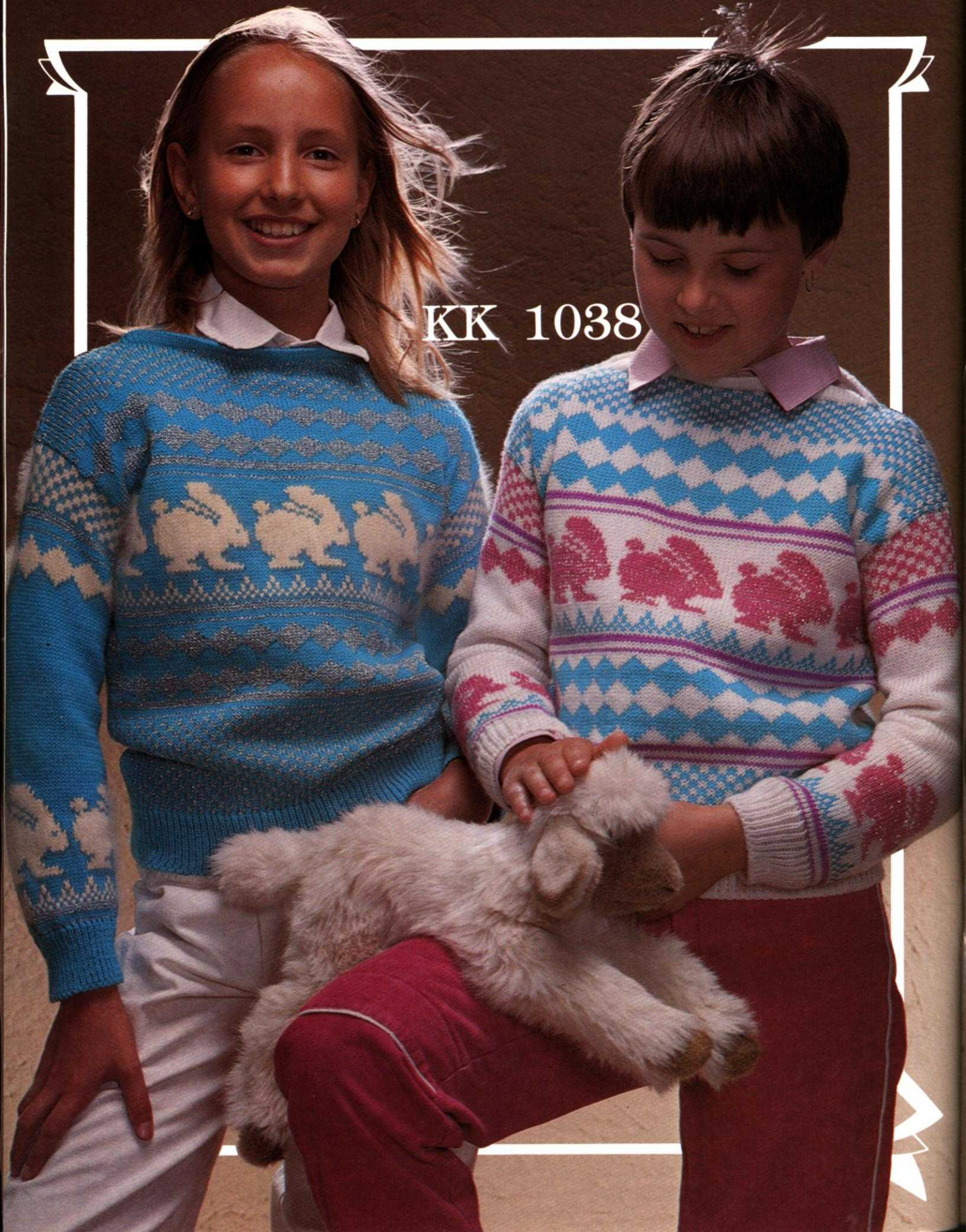



KK 1040A

KK 1040B

KK 1049

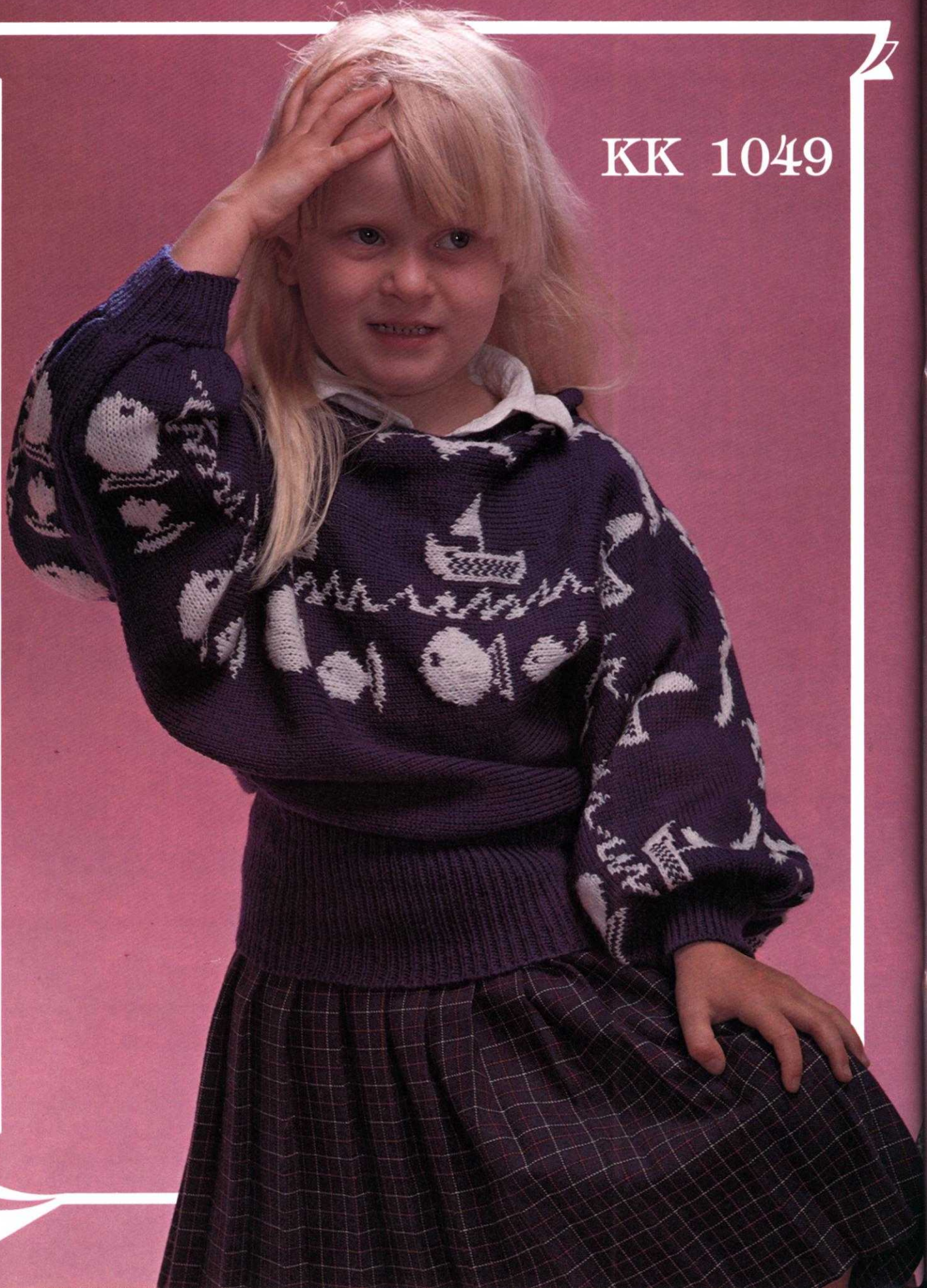

KK 1039

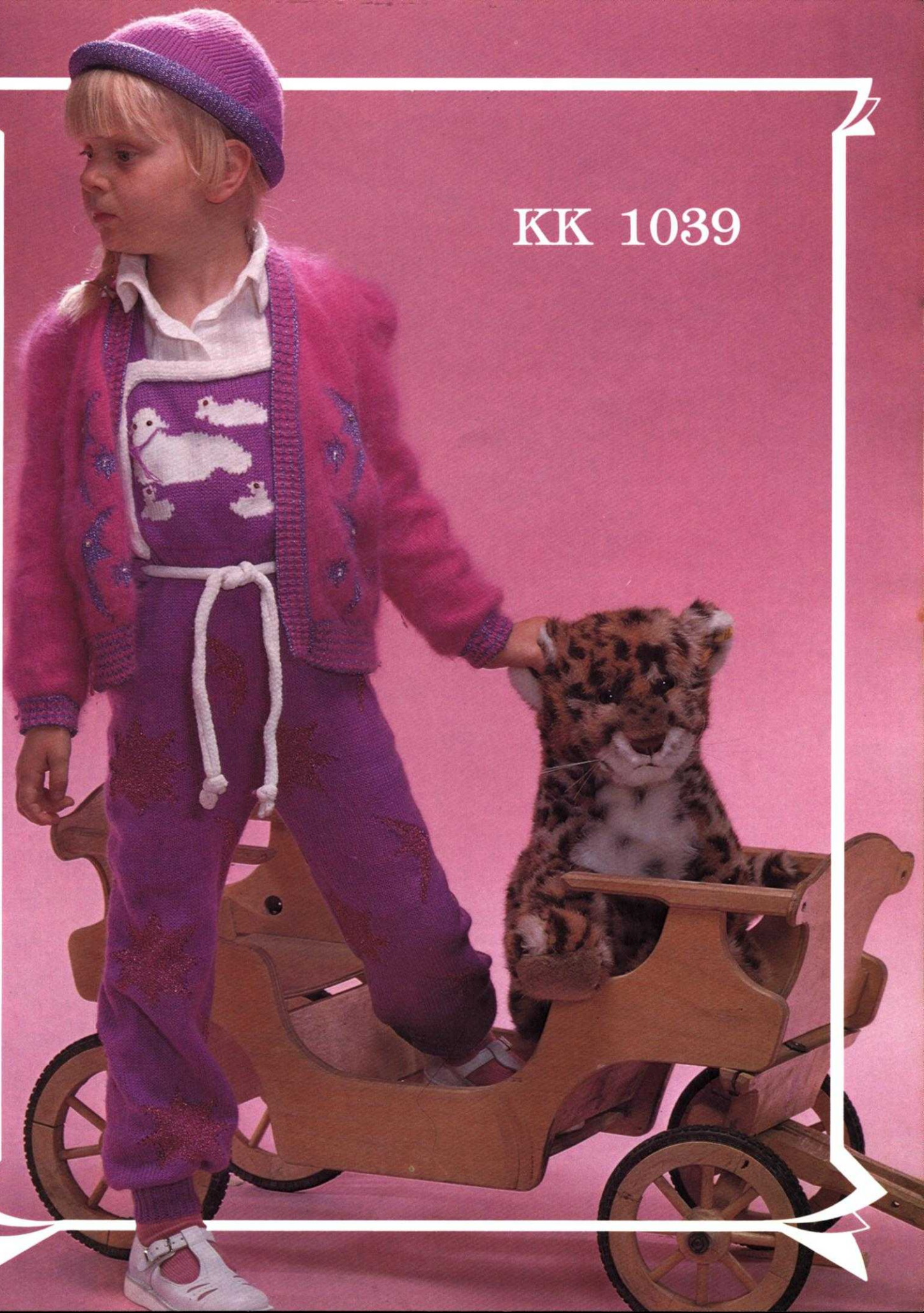

KK 1050



KK 1034



KK 1036



KK 1035





KK 1037

