

knitking

magazine





DK 1081

A woman with blonde hair styled in an updo is smiling and posing. She is wearing a textured, light brown and beige knit cardigan with a diamond pattern and a matching dark grey knit skirt. Underneath the cardigan, she wears a light-colored, button-down blouse with a ruffled collar. She is also wearing a necklace with a large, oval, amber-colored pendant and gold hoop earrings. Her right hand is on her hip, and her left hand is raised, touching a dark red wall. The background is a dark red wall with a white decorative frame around the woman. A green plant is visible in the lower right corner.

DK 1077



DK 1087

DK 1086

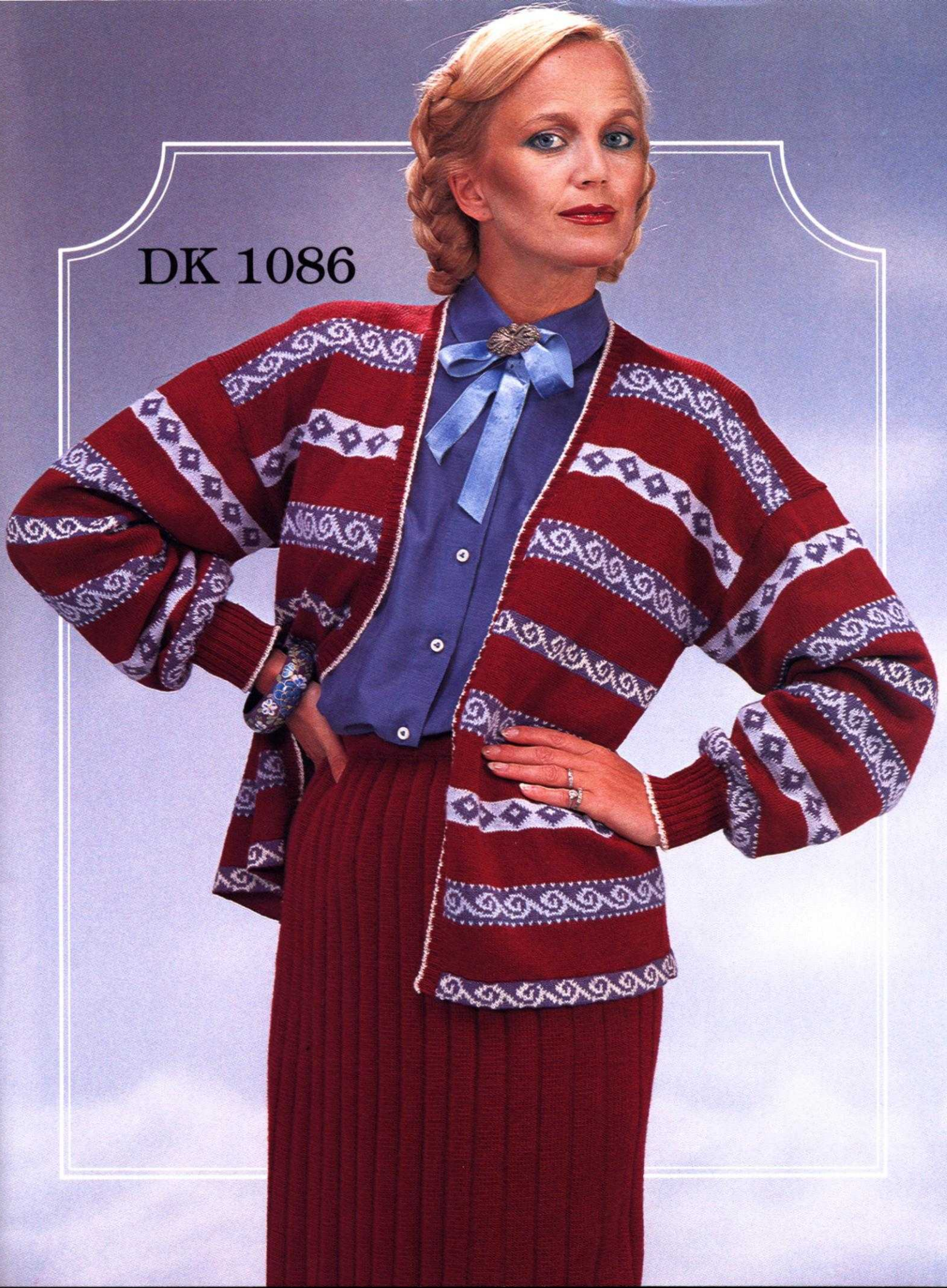



DK 1082

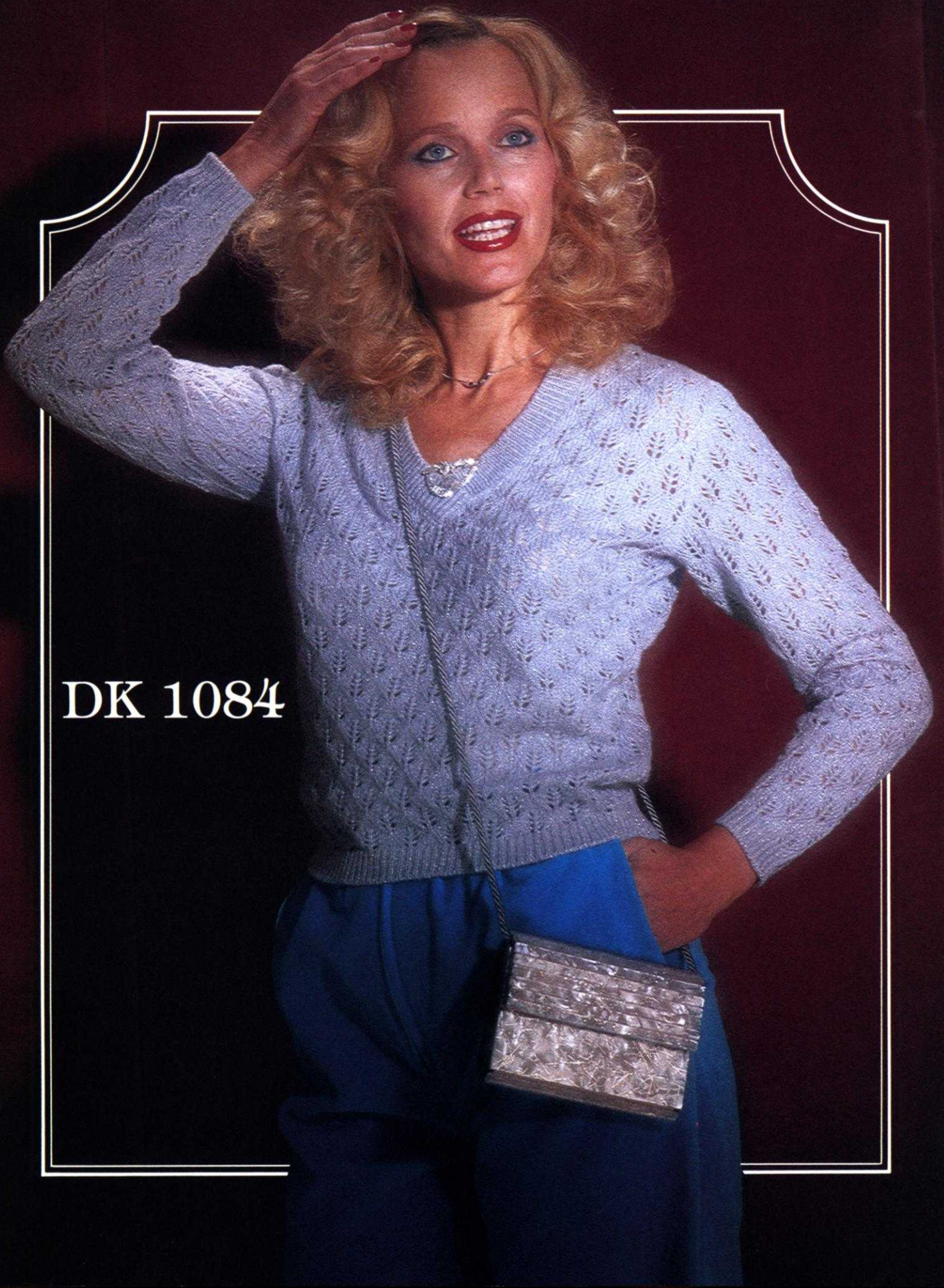

DK 1084

A woman with a long, thick blonde braid is modeling a two-piece knit outfit. The top is a sleeveless, open-front cardigan in a reddish-brown color with horizontal white stripes and a tassel at the end of the front panel. Underneath, she wears a white ribbed tube top. The bottom piece is a long, matching reddish-brown skirt with vertical white stripes. She is also wearing a gold cuff bracelet on her right wrist and a necklace. The background is dark with a white decorative frame around the woman.

DK 1075

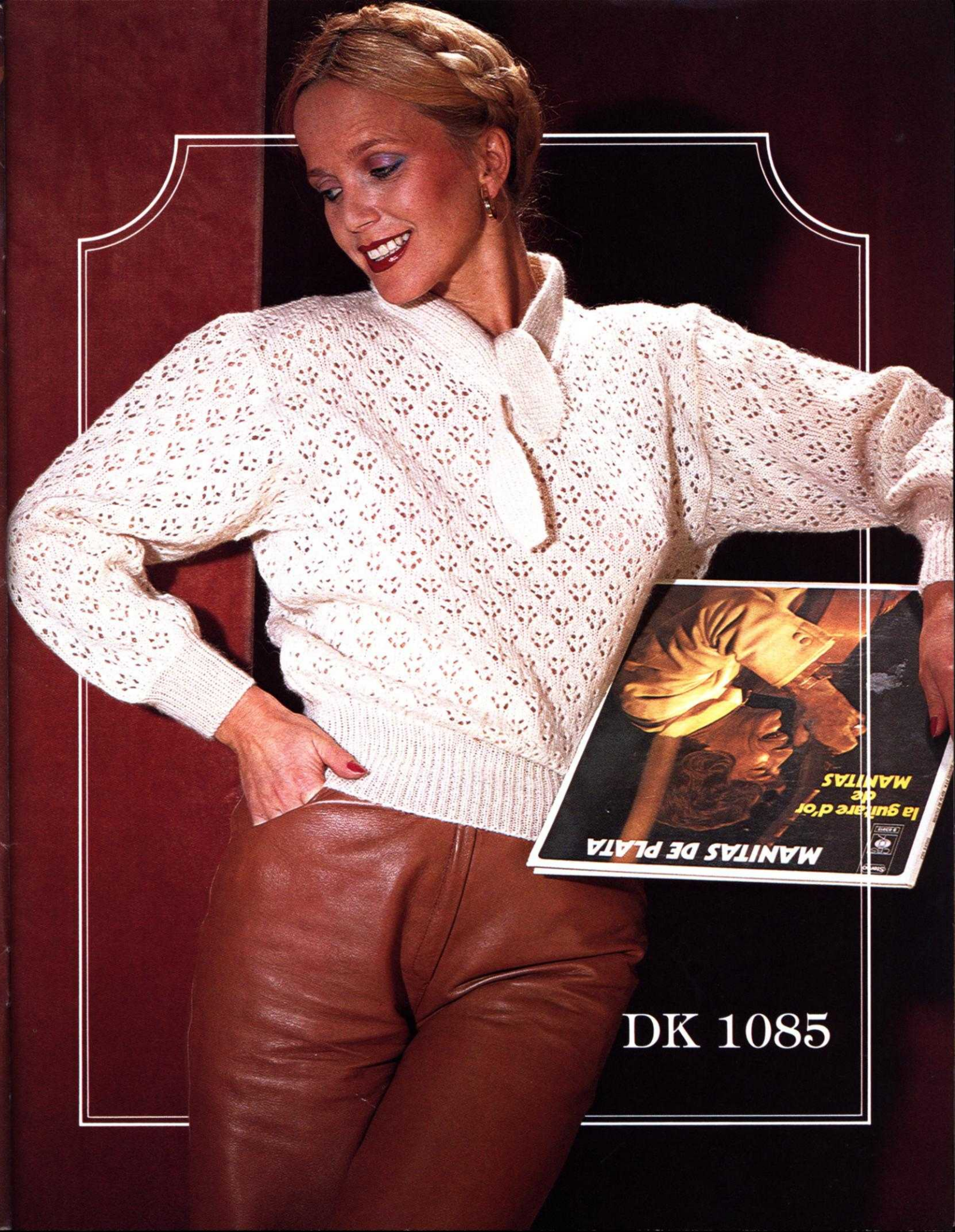

MANTAS DE PLATA

la guitare d'or
de
MANTAS

DK 1085

DK 1088



editorial

We get letters... lots of them... thank goodness!!! If we didn't hear from our readers we would not know what pleases them or what displeases them. The comments regarding our last issue were more profuse than usual and we were glad to know that most readers loved it. The complaints were regarding its late delivery and we apologize for that although at times it seemed to us that we would never get it out. Our printers suddenly suffered the malaise that is unfortunately becoming commonplace in today's troubled times, bankruptcy. Without notifying us, the printers premises were sealed by the receivers with all of our printing materials behind locked doors. We were faced with the problems of finding a new printer and doing much of our work over again.. Hence the delay. We have caught up some of the time with this issue and hopefully will make up for all of the lost time before the year is over.

COMPUTER DRAWN KNITLEADER CHARTS

A frequent request from readers is for more garments for the larger person or for a large range of sizes in our printed instructions. We do endeavor to satisfy all needs, but it is not easily possible to chart and print instructions for all sizes without substantially increasing the size of the magazine and our production costs.

We are fortunate to be living in an age of Computers and hopefully a specially designed Computer is going to solve the problems for us... What we do is furnish the owners of this very sophisticated special Computer with one set of accurately drawn full size charts in one size (say size 12), the Computer has a drafting machine as part of its equipment. It takes all the information from the original charts, the shapings for neck, armholes, waist, bust, etc., and electronically draws a master set of charts. The Computer is then programmed to reproduce and draw sets of charts full size, or to scale in any garment sizes the operator calls for.

Starting with this issue of KNITTING MAGAZINE, we intend offering certain selected garment charts in sizes 8 to 18. We will supply charts full size for owners of Knitleaders or any other charting accessory that works with full size charts, or in half size charts for use with Knit Contour/Radar accessories. We will give charts FREE with the purchase of Kits for selected garments and will sell charts separately to readers who prefer to use other yarns.

The production of Computer drawn charts is costly and our venture will only succeed if you take advantage of it. The fast, easy and accurate way to knit is with a Knitleader or similar accessory. The problem in the past has been the necessity to draw accurate charts. Our service eliminates that problem.

In this issue we offer sets of charts for 3 garments - DK 1081, DK 1083, DK 1087. Any set of charts in any size (from 8 to 18) can be purchased for \$5.00 per set plus 60¢ mailing costs. If you purchase the Yarn Kits for DK 1081 or DK 1087 directly from KNITTING, the Charts will be included free (you must specify size of garment and if you need one half or full size charts). DK 1083 is knitted in 4-ply worsted yarn and we are not furnishing a kit for it.

If this new venture is successful and we receive sufficient orders to cover our expenses, we will expand the service to cover more garments in our next issue.

















TABLE OF CONTENTS PAGE NO.



DK 1075 - Woman's Skirt, Jacket & Top	14
HP 1076 - Man's Pullover	15
DK 1077 - Woman's 3-Piece Suit	17
DK 1078 - Woman's Pullover	18
DK 1079 - Woman's Two-Piece Dress	20
KK 1080 - Boy's Pullover.	22
DK 1081 - Woman's Pullover & Skirt	23
DK 1082 - Woman's Dress	25
DK 1083 - Woman's Coat	26
DK 1084 - Woman's Lace Pullover	27
DK 1085 - Woman's Pullover	28
DK 1086 - Woman's Jacket & Skirt	29
DK 1087 - Woman's 3-Piece Suit	31
DK 1088 - Woman's Pullover	33
DK 1089 - Woman's Pullover	34
HP 1090 - Man's Sleeveless Pullover	35
HP 1091 - Man's Pullover.	36
DK 1092 - Woman's Pullover	37
DK 1093 - Woman's Jacket	39
DK 1094 - Woman's Vest	41

Publisher: KNITTING CORPORATION, 1128 Crenshaw Blvd., Los Angeles, Calif. 90019. Telephone: (213) 938-2079. Published bi-monthly. Subscriptions: USA-\$18.00 annually, single copies \$4.00. \$21.00 all other countries. The entire contents of KNITTING MAGAZINE are copyright and must not be reproduced in any shape or form without the express permission, in writing of the publisher. ©COPYRIGHT 1982 by KNITTING CORPORATION.

Pattern Symbols

Knitting – Chart Symbols

- () Size Symbols (2nd Size)
 < > 3rd Size
 ① Color Number
 Cast on
 Stitch
 Row
 Hem
 Bind off
 Stockinette stitch – worn on the Knit side.
 Stockinette stitch – worn on the Purl side.
 Knit 1, Purl 1 Ribbing
 Ribbing Pattern – worn on the Knit side.
 Ribbing Pattern – worn on the Purl side.
 Closed Dart
 Open Dart
 Put on a stitch holder
 Reverse 1 section
 On every other needle
 Number of Rows between Shapings. Make increase (or decrease) FIRST, then knit 4 rows. For example: 3 x 1  means decrease (or increase) 1 st., knit 4 rows; decrease 1 st., knit 4 rows; decrease 1 st., knit 4 rows; decrease 1 st., knit 4 rows. All decreasing (or increasing) without row numbers as shown must be shaped on every 2nd row.

-  Increase
 Increase 2 sts. With a transfer tool, move the sts. over the left (or right) leaving 2 empty needles at the point of increase. At the increase point, move 1 st. to the left, (or right) so that there is an empty needle on each side of a stitch. On each side of the center stitch, pick up a stitch from the row below and hang it onto the empty needle.

-  3 stitches on 1 needle. The 1st and 3rd stitch in a group of 3 has been hung on the 2nd or center needle.

-  Short Row increase or decrease; for instance on a flared skirt knitted sideways.

-  Pattern Stitch





-  Pattern Stitch – worn on the Knit side.

-  Pattern Stitch – worn on the Purl side.









-  Repeat

- I = Front
 II = Back
 III = Sleeve
 IV = Skirt Front
 V = Skirt Back
 VI = Collar
 VII = Pocket
 VIII = Band
 IX = Belt
 X = Cuff
 XI = Pants Front
 XII = Pants Back

Finishing – Chart Symbols

-  Match numbers on section for assembling.
 Ease
 Fold Line
 Turn to the wrong side and hem.

Stitch Symbols

-  Needles in holding position
 Needles back into working position.
 Empty needle (leave in working position)
 Needle not used (in the out of work position).
 Two stitches on 1 needle, either transferred from the right side or the left side, then put into holding position.
 Needle holding 2 stitches. Stitch has been transferred from the RIGHT.
 Needle holding 2 stitches. Stitch has been transferred from the LEFT.
 Center of garment section



General Instructions

HOW TO READ THE CHARTS AND INSTRUCTIONS

There are 3 sizes given for each Pattern in KNITKING MAGAZINE. Above each Chart for the different sizes, you will see that the first and smaller sizes might be shown as 8/10, the second size as (12/14) and the third as [16/18]. Check the measurements at the bustline and hips on the Charts to be certain that you will knit the correct size, remembering these are ACTUAL measurements of the completed section and that there must be a bigger allowance at the bustline and hipline for a Jacket or a Coat than there would be for a fitted dress or a fitted blouse or pullover. The question in your mind should be "How do I want this garment to fit...?"

When you have chosen the size you need, you can follow the Charts as shown. You will notice that where the shapings are the same FOR ALL SIZES, only 1 set of shapings will be shown on the first Chart and if you are knitting the 2nd or 3rd size, you simply follow the shapings as given for the first size. If the shapings are different, this will be shown on the Charts and you should follow them as given.

On the Charts, increases and decreases will be shown as follows

5x1

6 The number in the box means number of ROWS between the shapings, while the 5x1 above the box means - 1 st. 5x... so you will increase or decrease 1 st. every 6th row 5x.

ARMHOLE SHAPINGS - NECK SHAPINGS - SHOULDER SHAPINGS - are made on every 2nd row UNLESS there is a number in a box along side or below the shapings. The rule is... where there is no box with a number, the shaping is made on every 2nd row.

THE PRINTED INSTRUCTIONS

You can follow the printed instructions or use them in combination with the Charts. Where there is any question in the printed instructions, you have the Charts to show you how the section will look.

The 3 sizes, with the different amounts of cast on stitches and the different shapings will look like this...

Cast on 124 (136) [148] sts. You will

Cast on 124 sts. for the first size.

Cast on 136 sts. for the 2nd size.

Cast on 148 sts. for the 3rd size.

The important thing to remember is that you MUST READ AHEAD so that you KNOW what to do for the size you are knitting. Sometimes where the number of stitches are the same but the number of times different, you will find shapings like this...

3 sts. 1x (2x) [3x], 2 sts. 1x (2x) [3x], 1 st. 3x (4x) [5x].

As you see, you MUST read ahead in order to follow the instructions as given for YOUR SIZE. The rows will be different for the different sizes in some cases... Shoulder and Neck shapings usually are worked at the SAME TIME for the back section - so watch for the words AT THE SAME TIME.

HOLDING STITCHES ON THE LEFT SIDE WHILE SHAPING THE RIGHT SIDE

When knitting a section of garment in stockinette stitch, it is easy to hold the stitches on the left side while knitting the right half, but when knitting a Pattern Stitch such as a Norwegian Design, a Holding Position Design, Weaving, etc., you should use the following method. For the NECK SHAPING, we tell you to bind off the center sts., put the needles on the left into holding position and complete the right half first... so with a strand of contrast yarn, knit ALL of the left side stitches manually by hand, pulling each stitch back against the needle bed to the OUT OF WORK position. When the right side is completed, carefully pull the stitches held on contrast, forward into working position and as you do so, undo the contrast yarn, line up the needles (KNITKING AM 3 machine owners, put the stitches under the sinkers) and complete the left half.

If you own a Japanese machine, you may find that when knitting the right half with the left side held in this way, the sinker plate will mark the left side while you are knitting the right half. To prevent this marking, you can tape a piece of paper over the knitting, underneath the sinkers, or if you own a Reversing Bar, you can hang this onto the Sinkers while you are knitting the right half. When hanging the Reversing Bar, be sure the eyes of the bar go BETWEEN the Sinker Posts on the upper part of the bar so that the tips of the bar only - show above the needle bed.

FULL FASHION DECREASING OR INCREASING

For Stockinette stitch, always use the Full Fashion method for increasing or decreasing.

TO DECREASE: Hang the 3rd stitch onto the 2nd stitch then move the stitches in to fill the empty needle.

TO INCREASE: Move the 2 end stitches 1 needle outward, then pick up the 3rd stitch from the row below and hang it onto the empty needle.

FINISHING: Block all sections. For PULLOVERS, JACKETS, and DRESSES: Join front to back at sides and shoulders. Sew sleeves together and set in. Hem lower edge and sleeve edges if needed. For a double neckband or armhole band, sew 1 edge to the inside and 1 to the outside of neck or armhole. For a single ribbed band, sew 1 edge to the outside of neck or armhole edge. For a cardigan or jacket with buttonholes, finish buttonholes and sew on buttons.

PANTS: Join front to back at sides. Sew inside leg seams, then join center front and back. Make hem at waistline and insert elastic. Hem lower edge of pants legs.

THE SAMPLE SWATCH

Before you begin to knit any garment, you will need to knit a sample piece using the yarn you have chosen for your garment, so that you can check the stitch and row gauge which must measure the correct number of stitches and rows in 5 cm (2 inches).

For each Pattern in KNITKING MAGAZINE, we give you 3 tension numbers to work from and if you use the specified yarn for the garment, you should be able to get the correct stitch and row gauge using one of these numbers. Here is a very easy way to make your sample swatch and count the stitches and rows without actually counting, by using our KNITKING Converta Tape.

Supposing the Tension Numbers for the Stitch and Row Gauge are given as 5 to 7. Set the Tension Dial to the first number which is 5. With contrast waste yarn, and using the quick cast on method, cast on 60 stitches and knit 10 rows. Change to garment yarn and turn the Row Counter to 0. Knit 30 rows. Counting from each end, knit the 10th stitch on each side by hand with a small piece of contrast yarn. Leave the needles in working position and knit 30 rows (Row 60), then knit 4 rows with contrast waste yarn. Turn the Row Counter to 0 and the Tension Dial to 6 and with garment yarn, knit 30 rows. Mark the 10th stitch on each side as you did before, knit 30 rows, then 4 rows with contrast waste yarn. Turn the Row Counter to 0 and with Tension 7, repeat the above once more, ending with 10 rows of contrast waste yarn. Remove the work from the machine by passing the Slide across the needles without yarn (sometimes called 'dropping').

Pull and stretch the sample piece both lengthwise and diagonally from corner to corner, then lengthwise again. Do not count the stitches and rows immediately, but allow the sample to rest for several hours or even over night. This will allow the stitches and rows to return to their basic form.

When your sample has rested and you are ready to count the stitches and rows, the KNITKING CONVERTA TAPE will do the counting for you without any counting on your part. Use the Tape as follows:

Measure the stitches with the TAPE, BETWEEN the 40 stitches marked with contrast waste yarn. Push the SLIDE so that the LEFT EDGE lines up to this exact measurement. Now look down along side the SLIDE and find the number 40 on the TAPE. The number directly opposite on the SLIDE will be your Stitch Gauge to 5 cm (2"). To find the number of rows in 5 cm (2"), place the TAPE to measure over the 60 rows, push the SLIDE to this number with the left edge lined up, the look for the number 60 on the TAPE and directly opposite this will be the number of rows to 5 cm (2")

If you do not own a KNITKING CONVERTA TAPE, you must mark a 5 cm (2 inch) square in the center of the knitting, then count the number of stitches and rows within the square.

DK 1075



WOMAN'S SKIRT, JACKET & TOP

SIZES: 6 (8/10)

YARN: Venetia and Amore

GRAMS:

color 1 850 950 - Venetia
 color 2 50 50 - Amore
 color 3 50 50 - Amore
 color 4 250 250 - Amore
 color 5 50 50 - Amore

TENSION: - JACKET - 6 to 8
 - SKIRT - 4.2 to 5.1
 RIBBED TOP -

GAUGE:

JACKET: 14 sts. 20 1/2 rows = 5 cm (2")

SKIRT: 14 sts. 26 rows = 5 cm (2")

TOP:

The Skirt is knitted sideways.
 A Tuck stitch Pattern. Use
 any Punch Card with every other
 needle selection and leave the
 Card on STOP. Use COLOR CHANGER.
 Bands are K1, P1 Ribbing.

FINISHING: See General Instructions.

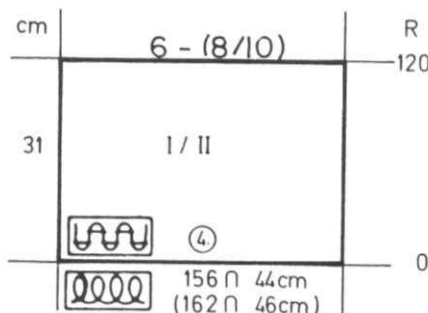
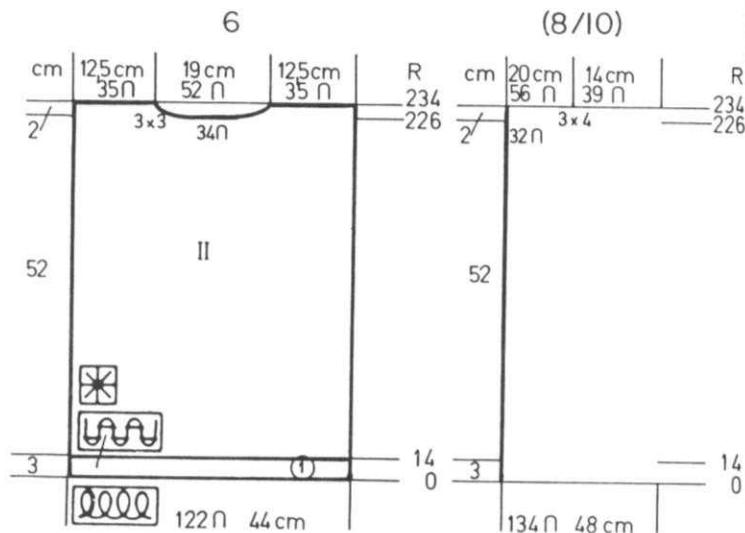
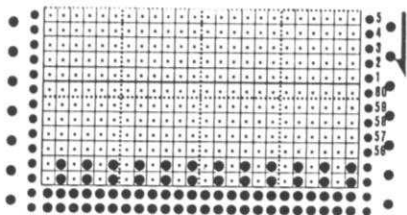

CAMISOLE TOP - Make 2 sections the same.

With color 4, cast on 156 (162) sts. and work K1, P1 Ribbing. After Row 120, bind off.

JACKET BACK: II

PATTERN: USE COLOR CHANGER and any Punch Card with every other needle selection. Leave Card on STOP.

Knit 9 rows color 1

Set KC on right.

Knit 1 row to the left.

Push in BOTH TUCK BUTTONS,

Change to color 2, knit 2 rows.

Release Tuck Buttons and KC.

Change to color 1, Knit 9 rows.

Set KC, knit 1 row to the left.

Push in BOTH TUCK BUTTONS, change to color 3 - etc., etc.

Cast on 122 sts. with color 1 and

work 14 rows K1, P1 Ribbing.

Continue in Pattern.

After Row 226, bind off the

center 34 sts., put the

needles on the left into holding

position and complete the right

side first.

*After Row 234, bind off the remaining sts.

Bring the needles on the left into

working position, knit 1 row to

the left side, turn the Row Counter

back to 226 and complete the

left half. Follow the instructions

from *.

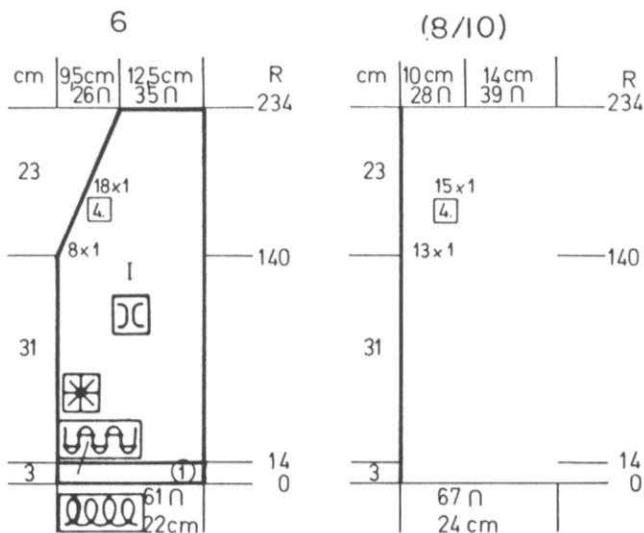

JACKET FRONT: I Make 1, reverse 1.

Cast on 61 (67) sts. with color 1

and work 14 rows K1, P1 Ribbing.

Continue in Pattern.

After Row 140, ON NECK SIDE, de-

crease 1 st. every 2nd row 8x (13x)

then every 4th row 18x (15x).

After Row 234, bind off the remaining

sts.

DK 1075

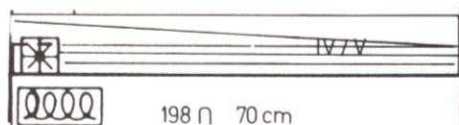

SKIRT: - Tension 4.2 to 5.1
USE COLOR CHANGER

With contrast waste yarn, cast on 198 sts. Knit 10 rows, 1 row with Ravel Cord to the LEFT. With color 1, knit 1 row to the RIGHT.

*CARD ON STOP, SET KC. Knit 1 row to the LEFT. Push in BOTH TUCK BUTTONS, change to color 2 and knit 2 rows. Release Buttons and KC, change to color 1. Knit 2 rows. BEGIN SHORT ROWS.

ON THE RIGHT, put into holding position 26 sts., knit 2 rows, then put into holding position 54 sts., knit 2 rows, 54 sts., knit 2 rows. 66 sts. remain. All needles in working position, knit 1 row. REPEAT FROM *, changing the colors for the 2 TUCK ROWS each time. REPEAT from * 60 or 70 times. End with knitting 2 rows color 1 then remove onto contrast waste yarn. Press carefully, then weave the open sts. together and remove waste yarn. Work 2 rows single crochet around lower edge. Make small hem for waistband and pull elastic through.

JACKET FRONT BANDS: Make 2.

Cast on 180 sts. with color 1 and work 10 rows K1, P1 Ribbing. Bind off or remove onto contrast waste yarn.

JACKET BACK NECK BAND:

Cast on 56 (63) sts. with color 1 and work the same as for Front Bands.

ARMBANDS: - Make 2.

Cast on 104 (114) sts. with color 1 and work the same as for Front Bands.

HP 1076

MAN'S PULLOVER

SIZES: 40 (42) [44]
YARN: Amore
GRAMS:
color 1 450 450 500
color 2 400 400 450
TENSION: 9 or 10
GAUGE: 14 sts. 15 rows = 5 cm (2")

Fairisle (Norwegian) Design. Punch your own Card. The bands are K1, P1 Ribbing.

FINISHING: See General Instructions.

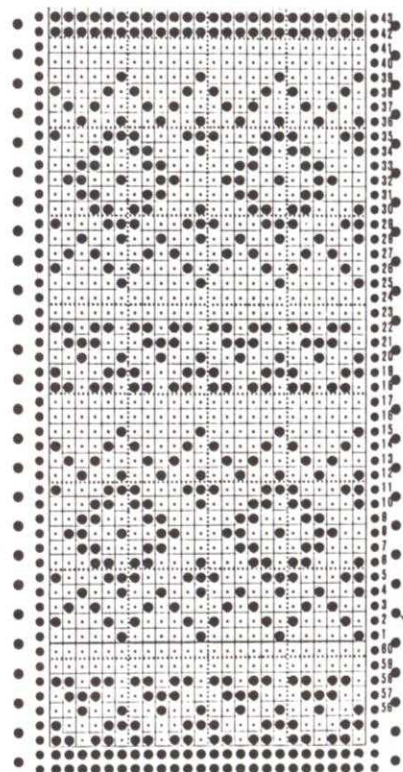

SLEEVES: III

Cast on 84 (88) [90] sts. with color 1 and work 20 rows K1, P1 Ribbing.

Continue in Pattern. ON EACH SIDE, increase 1 st. every 8th row 14x (14x) [15x]. After Row 152 (156) [160], SHAPE CAP: ON EACH SIDE bind off - Please follow the bind offs for YOUR SIZE as shown on the Chart.

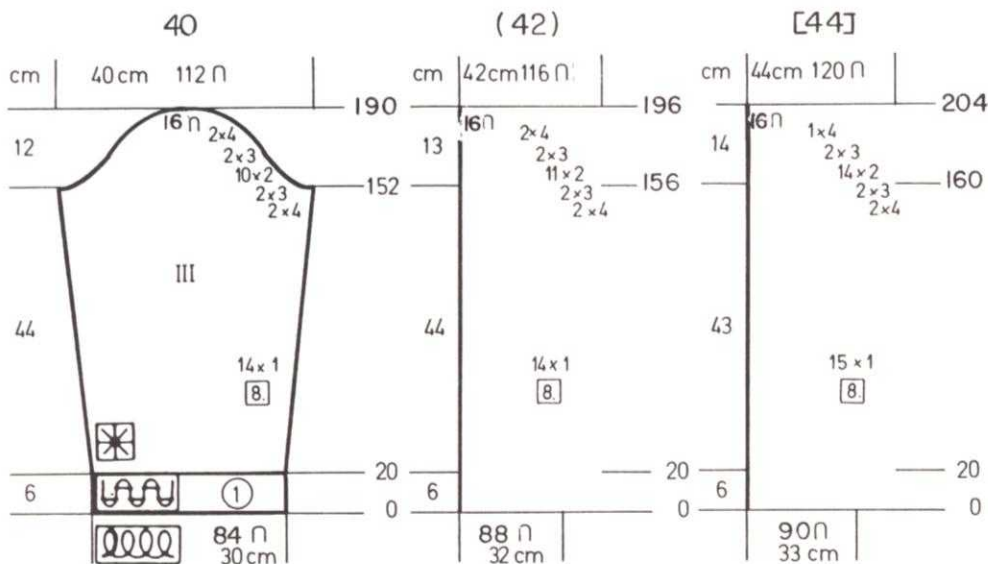

HP 1076

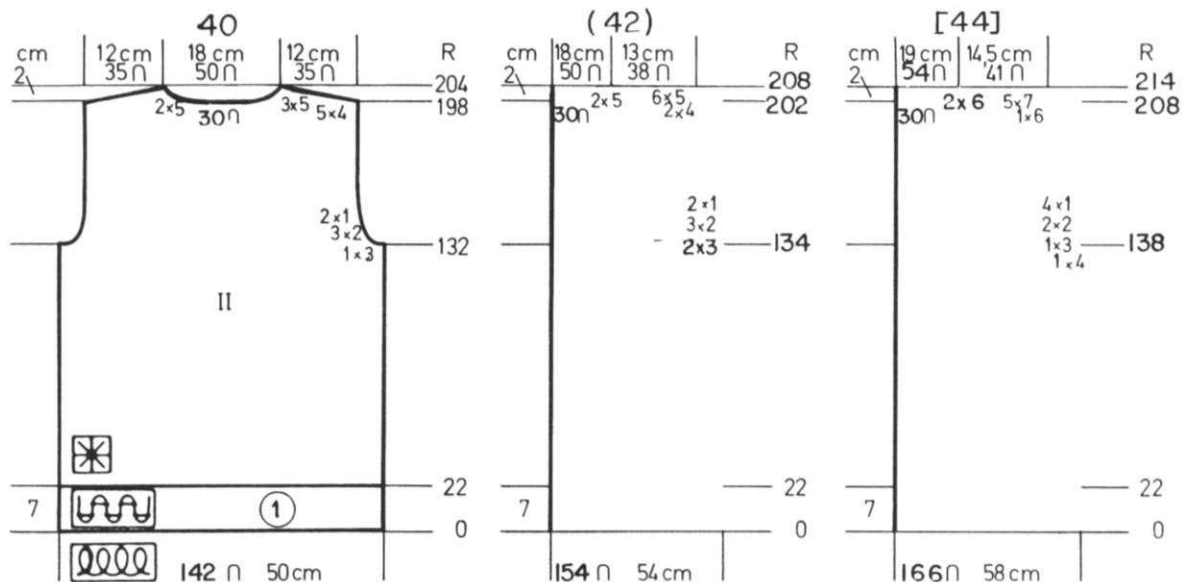

BACK: II

Cast on 142 (154) [166] sts. with color 1 and work 22 rows K1, P1 Ribbing.

Continue in Pattern.
Knit to Row 132 (134) [138].
SHAPE ARMHOLE: ON EACH SIDE,
bind off

3 sts. 1x, 2 sts. 3x, 1 st. 2x.
(3 sts. 2x, 2 sts. 3x, 1 st. 2x).
[4 sts. 1x, 3 sts. 1x, 2 sts. 2x,
1 st. 4x].

After Row 198 (202) [208], bind off the center 30 sts., put the needles on the left into holding position and complete the right side first.

*SHAPE SHOULDER AND NECK AT THE SAME TIME.

FOR SHOULDER, bind off

4 sts. 5x, 5 sts. 3x
(4 sts. 2x, 5 sts. 6x)
[6 sts. 1x, 7 sts. 5x]

FOR NECK, bind off

5 sts. 2x
(5 sts. 2x)
[6 sts. 2x].

Bring the needles on the left into working position, knit 1 row in Pattern to the left side, turn the Row Counter back to 198 (202) [208] and complete the left half. Follow the instructions from *.

NECKBAND:

Cast on 166 (176) [176] sts. with color 1 and work 10 rows K1, P1 Ribbing.
Bind off or remove onto contrast waste yarn.

FRONT: I

Work the front the same as the back to Row 132 (134) [138].
SHAPE ARMHOLE same as the back and after Row 174 (174) [172] bind off the center 16 (16) [20] sts., put the needles on the left into holding position and complete the right side first.

*ON NECK SIDE, bind off
3 sts. 2x, 2 sts. 3x, 1 st. 5x for all sizes.

After Row 198 (202) [208], SHAPE SHOULDER same as the back.
Bring the needles on the left into working position, knit 1 row in Pattern to the left side, turn the Row Counter back to 174 (174) [172] and complete the left half. Follow the instructions from *.

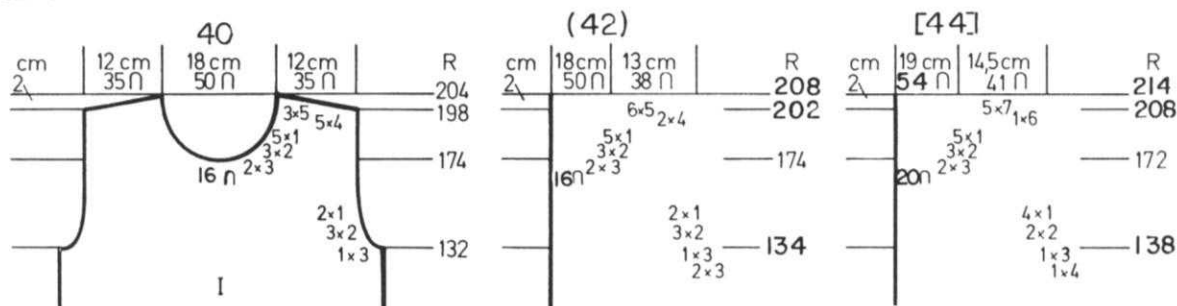

DK 1077



WOMAN'S 3-PIECE SUIT

SIZES: 8/10 (12/14)
 YARN: Sport weight yarn
 GRAMS:
 color 1 500 550
 color 2 750 800
 TENSION: 10
 GAUGE: 13 1/2 sts. 14 1/2 rows =
 5 cm (2")

The Skirt is Stockinette stitch.
 The Jacket is a Norwegian Design
 worn on the purl side. The Vest
 is Norwegian Design worn on the
 knit side.

FINISHING: See General Instructions.
 Work single crochet around all
 edges of Jacket using 4 strands of
 color 2. Work 1 row single crochet
 around lower edge of skirt.
 Finish edges of Vest same as Jacket.

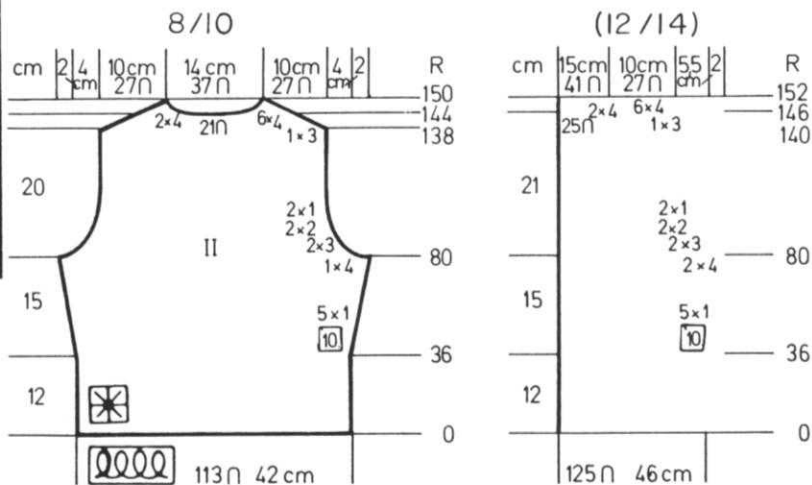

VEST BACK: II

Cast on 113 (125) sts. with color 1 and work in Pattern.

After Row 36, ON EACH SIDE, increase 1 st. every 10th row 5x. After Row 80, SHAPE ARMHOLE: ON EACH SIDE, bind off 4 sts. 1x, (2x) 3 sts. 2x, 2 sts. 2x, 1 st. 2x.

After Row 138 (140), SHAPE SHOULDER and WATCH FOR NECK SHAPING.

FOR SHOULDER, ON EACH SIDE, bind off 3 sts. 1x, 4 sts. 6x for both sizes.

FOR NECK, after Row 144 (146) bind off the center 21 (25) sts. put the needles on the left into holding position and complete the right side first.

*ON NECK SIDE, bind off 4 sts. 2x. Bring the needles on the left into working position, knit 1 row in Pattern to the left side, turn the Row Counter back to 144 (146) and complete the left half. Follow the instructions from * and don't forget to complete the shoulder shaping.

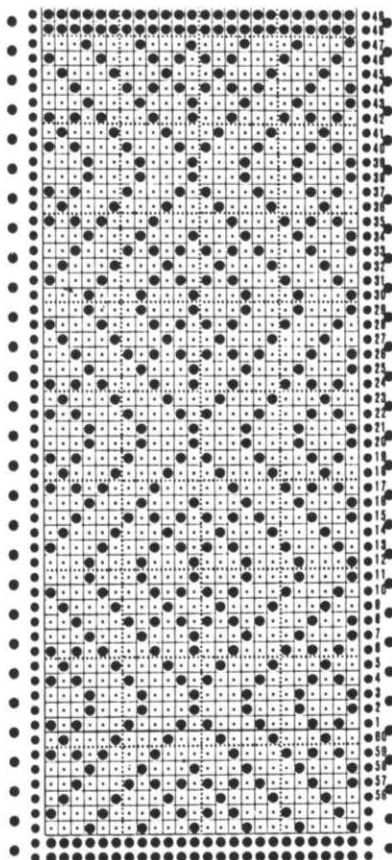

SKIRT: IV/V Make 4 sections the same.

Begin at waist. Cast on 57 (62) sts. with color 2 and work Stockinette stitch.

After Row 20, ON EACH SIDE, increase 1 st. every 8th row 8x, and after Row 90, increase 1 st. EACH SIDE every 16th row 8x. Knit to Row 252, then bind off. Make 3 more sections the same.

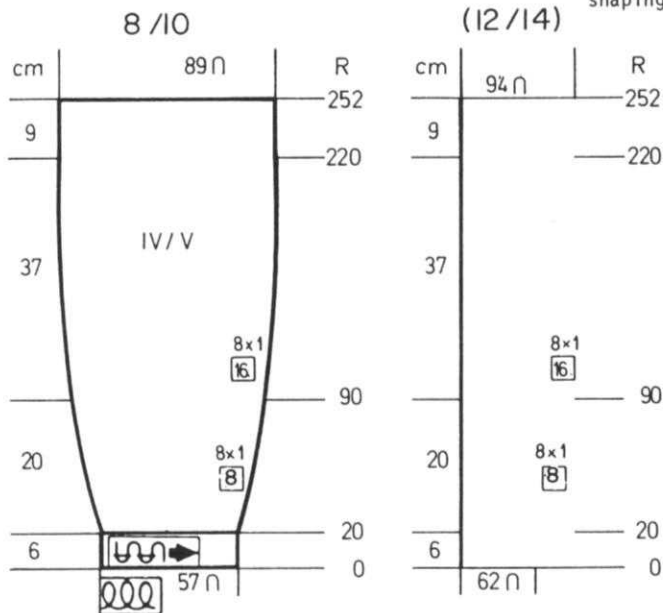

STOP PRESS KNITTING SEMINAR 1982 - OCTOBER 11TH THRU 16TH

Letters are coming in from readers regarding Hotel accomodations... so here are a few suggestions.

Wilshire Dunes Motor Hotel - 4300 Wilshire Blvd., Los Angeles, CA 90010
(nearest to our premises) Tel: 213-938-3616

Ambassador Hotel - 3400 Wilshire Blvd., Los Angeles, CA 90010
Tel: 213-387-7011

Hilton - Downtown Los Angeles - 930 Wilshire Blvd. 90017
Tel: 213-629-4321

Hilton - Beverly Hills - 9876 Wilshire Blvd., 90210
Tel: 213-274-7777

Hilton Hotels - 3540 So. Figueroa, Los Angeles 90007
Tel: 213-748-4141

Wilshire Hyatt House - 3515 Wilshire Blvd., Los Angeles CA 90010
Tel: Toll Free - 800-228-9000

Century Plaza Hotel - Beverly Hills - Century City area - Avenue of the Stars 90067 Tel: 213-277-2000

Olympian Motor Hotel - 1903 W. Olympic Blvd., Los Angeles 90006
Tel: 213-385-7141

Our printers left some material out of this edition of KNITTING MAGAZINE. Please clip the Charts below to page 18 of your magazine. They are for Pattern DK 1077

DK 1077

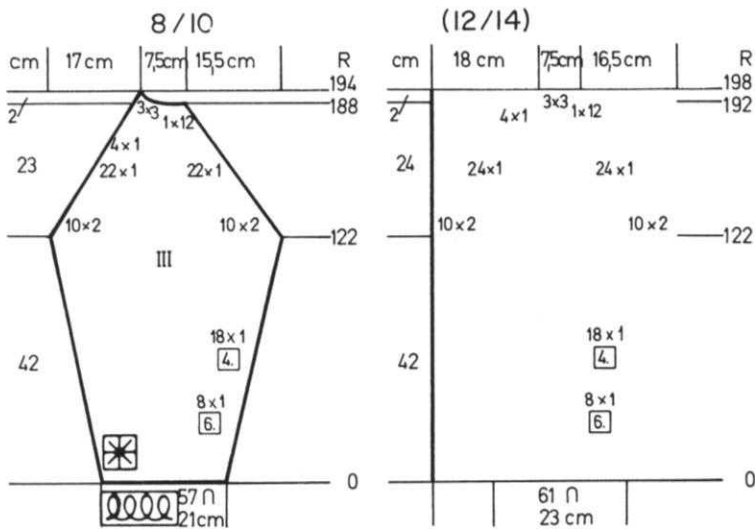
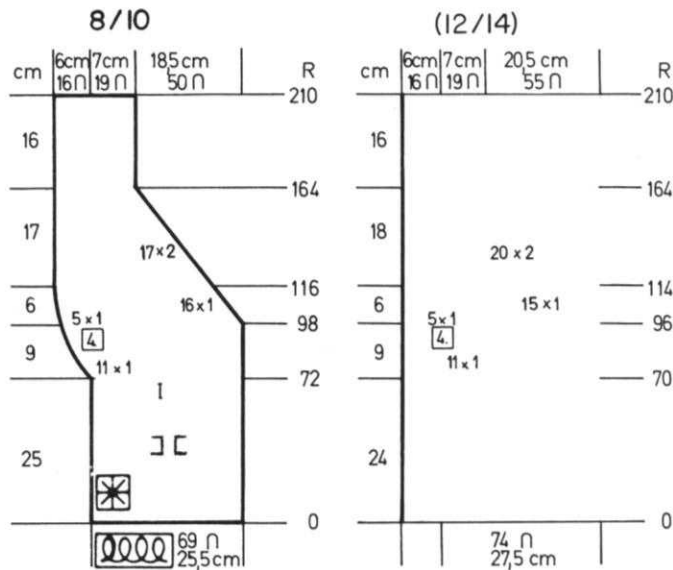
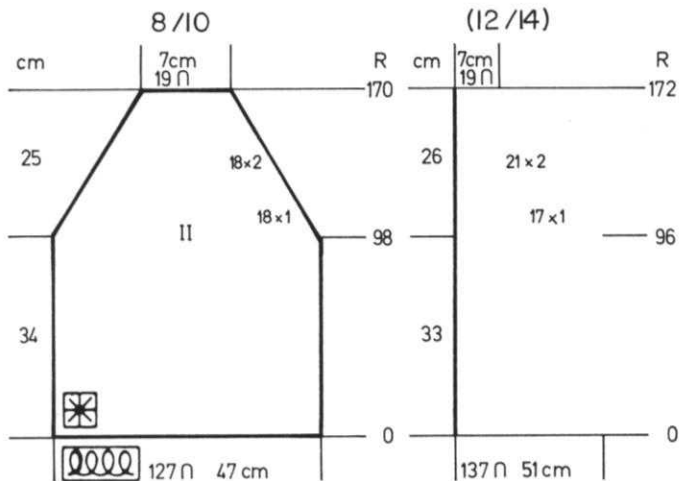

DK 1078

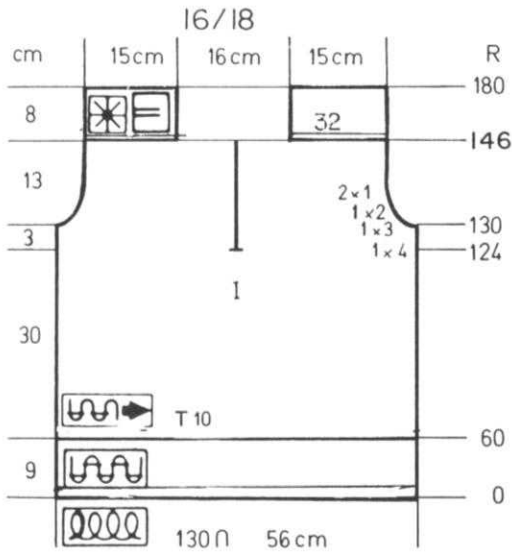

FRONT: I

Work the front the same as the back to Row 124. Divide in the center and hang the center st. onto neighboring needle. Put the needles on the left into holding position and complete the right side first.

*Knit to Row 130. SHAPE ARMHOLE same as the back and after Row 146, knit 4 rows with DOUBLE strands of gold. Remove onto contrast waste yarn. Hang the sts. back onto the machine, decreasing to 32 sts. (hang 2, 2, 1, 2, 2, 1 etc.) Continue in SLIP STITCH Pattern same as the back to Row 180. Bind off.

Hang the left side back onto machine and follow the instructions from * (Be sure to hang the sts. on the correct needles to match Pattern).

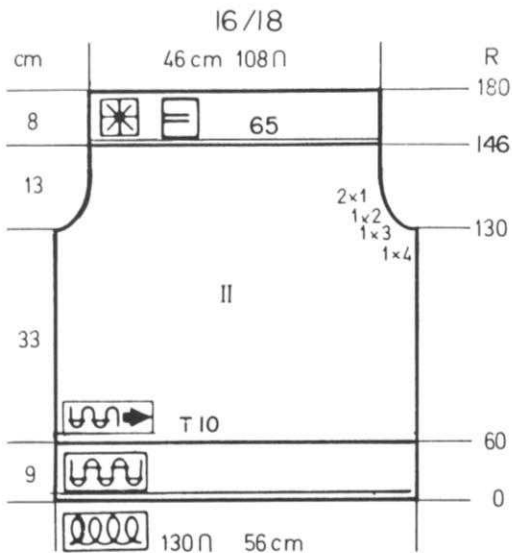

BACK: II

1 x 1 RIBBER CAST ON using Gold DOUBLED - Tension 4/4. Cast on 130 sts. After the 4 rows for the cast on, change to Chenille and knit to Row 60. Transfer the Ribber sts. and change to Tension 10 and Stockinette stitch using 1 strand of fine yarn, plus the gold together.

After Row 130, SHAPE ARMHOLE: ON EACH SIDE, bind off 4 sts. 1x, 3 sts. 1x, 2 sts. 1x, 1 st. 2x.

After Row 146, with DOUBLE strands of gold, knit 4 rows Stockinette stitch. After Row 150, remove the sts. onto waste yarn.

Hang the sts. back onto the machine decreasing to 65 sts. (hang*2 - 2 - 1, 2, 2, 1 and REPEAT from *). WORK SLIP STITCH PATTERN to Row 180 using Chenille and DOUBLE strands of gold as shown along side the Punch Card.

After Row 180, bind off.

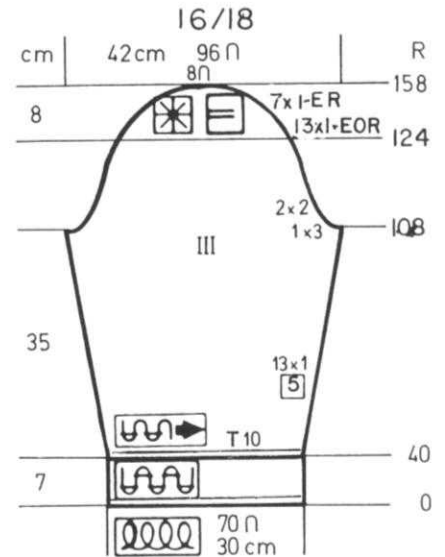

SLEEVES: III

RIBBER CAST ON 70 sts. Tension 4 with DOUBLE STRANDS OF GOLD. After the 4 rows of cast on, change to Chenille and K1, P1 Ribbing. After Row 40, transfer the Ribber sts. to main machine and change to Tension 10. Continue in Stockinette stitch. Work 2 rows DOUBLE GOLD, then continue with color 1 and gold together. After Row 108, SHAPE CAP: ON EACH SIDE, bind off 3 sts. 1x, 2 sts. 2x. Knit to Row 124.

Knit 4 rows with double strands of gold then remove the sts. from the machine onto waste yarn. Hang the sts. back onto machine decreasing to 48 sts. (hang 2-2-1 etc.) Continue in SLIP STITCH PATTERN with CHENILLE and DOUBLE GOLD.

ON EACH SIDE, decrease 1 st. every 2nd row 13x, then 1 st. EVERY ROW 7x. After Row 158, bind off the remaining sts.



DK 1079



WOMAN'S TWO PIECE DRESS

SIZES: 4/6 (8/10)
 YARN: Fortissima
 GRAMS: 600 650
 TENSION: TOP - 8 or 9
 BANDS - 4
 SKIRT - 7

GAUGE:
 TOP: 13 sts. 18 rows = 5 cm (2")
 SKIRT: 14 sts. 19 rows = 5 cm (2")

The Skirt is Stockinette stitch and the Top is a Lace Pattern with a Tuck stitch for the bands. Punch your own Cards.

FINISHING: See General Instructions. The Purl side is the right side.

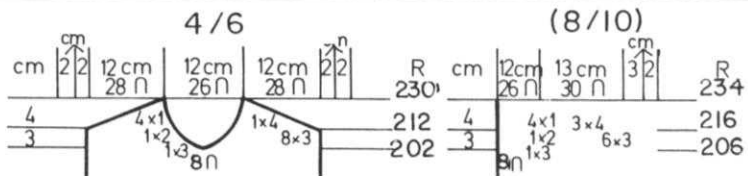

TOP FRONT: 1

Work the front the same as the back to Row 202 (206). Bind off the center 8 sts., put the needles on the left into holding position and complete the right side first.
 *ON NECK SIDE, bind off 3 sts. 1x, 2 sts. 1x, 1 st. 4x and after Row 212 (216), SHAPE SHOULDER same as the back. Bring the needles on the left into working position, knit 1 row to the left side, turn the Row Counter back to 202 (206) and complete the left half. Follow the instructions from *.

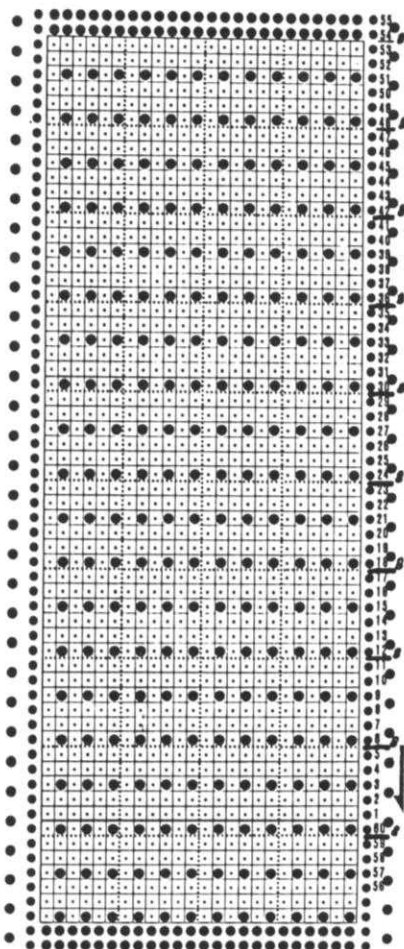

You must knit 8 rows between each of the marked rows as shown on the Punch Card.

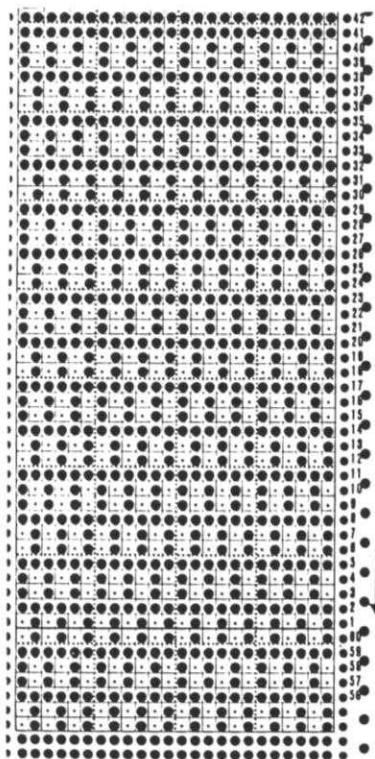

COLLAR:

Cast on 100 sts. and work Pattern 2 to Row 54. Bind off LOOSELY.

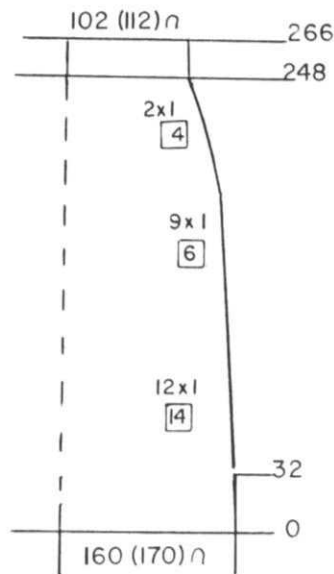

SKIRT: IV/V - Make 2 sections the same.

Cast on 160 (170) sts. and work Stockinette stitch. After Row 32, ON EACH SIDE, decrease 1 st. every 14th row 12x, every 6th row 9x, every 4th row 2x. After Row 248, remove the sts. onto waste yarn. Hang the sts. back onto the machine, decreasing 12 sts. evenly across. Counter at 248, knit to Row 266. Bind off LOOSELY. Make another section the same. Sew side seams, turn up hem and fold waistband in half and sew to the inside leaving an opening for elastic. Pull elastic through casing and close seam.

DK 1079

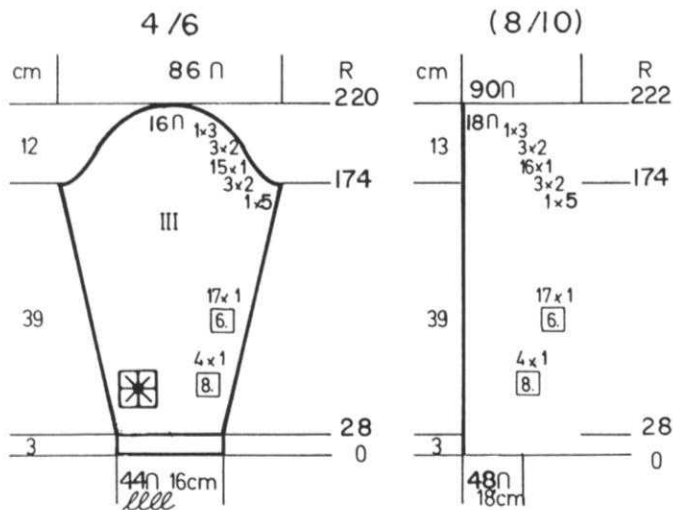
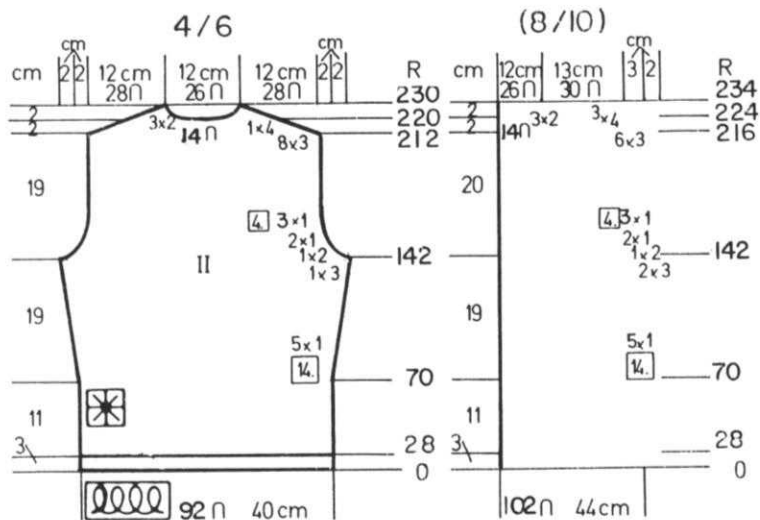

SLEEVES: III

Cast on 44 (48) sts. and work in Pattern 2 to Row 28 (tension 4). Change to Tension 8 or 9 and continue in Pattern 1.
 ON EACH SIDE, increase 1 st. every 8th row 4x, every 6th row 17x.
 After Row 174, SHAPE CAP:
 Please follow the CAP SHAPING as shown on the Chart for your size.
 After Row 220 (222), bind off the remaining sts.

TOP BACK: II

Cast on 92 (102) sts. and work Pattern 2 with tension 4 to Row 28. Change to Tension 8 or 9 and continue in Pattern 1.
 After Row 70, ON EACH SIDE, increase 1 st. every 14th row 5x.

After Row 142, SHAPE ARMHOLE:

ON EACH SIDE, bind off 3 sts. 1x, 2 sts. 1x, 1 st. 2x, then every 4th row 1 st. 3x. (3 sts. 2x, 2 sts. 1x, 1 st. 2x, then every 4th row 1 st. 3x).

After Row 212 (216), SHAPE SHOULDER and WATCH FOR NECK SHAPING.

FOR SHOULDER, ON EACH SIDE bind off

3 sts. 8x, 4 sts. 1x. (3 sts. 6x, 4 sts. 3x).

FOR NECK: After Row 220 (224) bind off the center 14 sts., put the needles on the left into holding position and complete the right side first.

*ON NECK SIDE, bind off 2 sts. 3x. Bring the needles on the left into working position, knit 1 row to the left side (watch Pattern) turn the Row Counter back to 220 (224) and complete the left half. Follow the instructions from *.



KK 1080



BOY'S PULLOVER

SIZES Small (Medium)
YARN: Sport weight yarn
 color 1 200 250 - Lt. Blue
 color 2 150 200 - Med. Blue
 color 3 100 150 - Navy Blue
 color 4 100 150 - Lt. Grey
 color 5 100 150 - Dk. Grey
TENSION 10
GAUGE: 13 sts, 14 rows = 5 cm (2")

A Norwegian Design with bands in K1, P1 Ribbing.

FINISHING: See General Instructions.

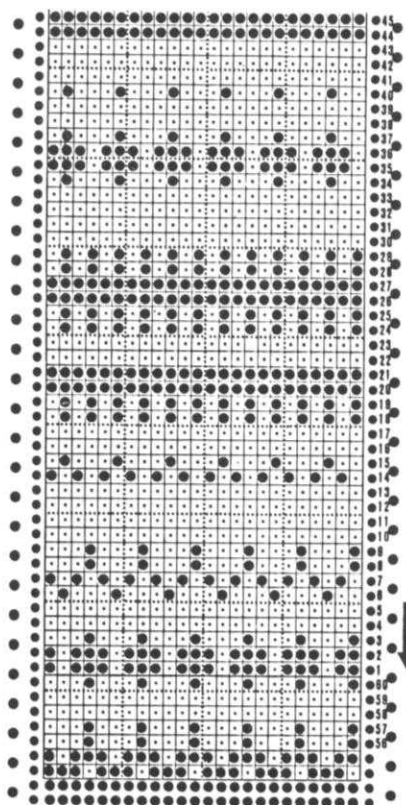

- 2 Rows - color 1 (Set Card)
- *4 Rows - colors 1 & 2
- 2 Rows - color 1
- 2 Rows - colors 1 & 3
- 2 Rows - colors 4 & 3
- 2 Rows - color 1
- 4 Rows - colors 1 & 5
- 2 Rows - color 1
- 2 Rows - color 2
- 2 Rows - colors 2 & 4
- 2 Rows - color 2
- 4 Rows - colors 1 & 5
- 2 Rows - color 1
- 4 Rows - colors 1 & 3
- 2 Rows - colors 2 & 3
- 2 Rows - color 2
- 2 Rows - color 1
- 4 Rows - colors 1 & 4
- 2 Rows - color 1
- 2 Rows - colors 4 & 5
- 2 Rows - color 1
- REPEAT FROM *

SLEEVES: III

Cast on 58 (62) sts. with color 2 and work 22 rows K1, P1 Ribbing. Continue in Pattern. ON EACH SIDE, increase 1 st. every 8th row 13x for both sizes. After Row 124, SHAPE CAP: Please follow the instructions as shown on the Chart for your size for the bind-offs on each side.

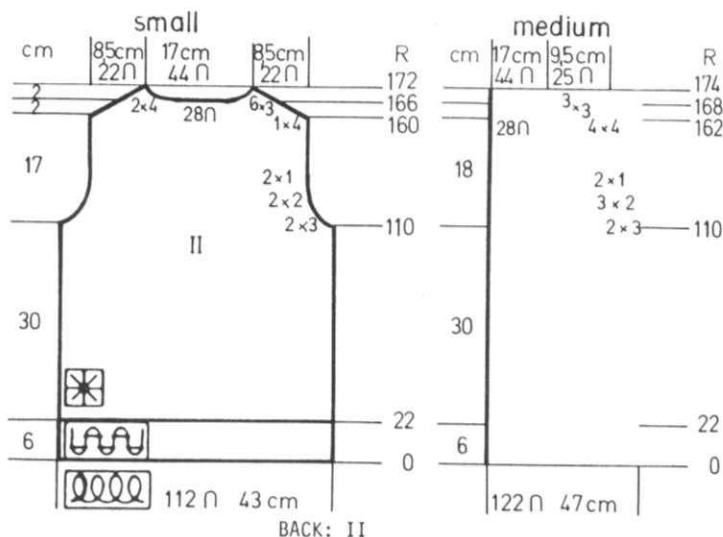

NECKBAND:

Cast on 152 sts. with color 2 and work 8 rows K1, P1 Ribbing. Bind off or remove onto waste yarn.

FRONT: I

Work the front the same as the back to Row 148 (150). Bind off the center 16 sts., put the needles on the left into holding position and complete the right side first. *ON NECK SIDE, bind off 3 sts. 2x, 2 sts. 2x, 1 st. 4x for both sizes. After Row 160 (162) SHAPE SHOULDER same as the back. Bring the needles on the left into working position, knit 1 row in Pattern to the left side, turn the Row Counter back to 148 (150) and complete the left half. Follow the instructions from *.

Cast on 112 (122) sts. with color 2 and work 22 rows K1, P1 Ribbing. Continue in Pattern. AFTER Row 110, SHAPE ARMHOLE: ON EACH SIDE, bind off 3 sts. 2x, 2 sts. 2x, 1 st. 2x. (3 sts. 2x, 2 sts. 3x, 1 st. 2x). After Row 160 (162), SHAPE SHOULDER and WATCH FOR NECK SHAPING. *FOR SHOULDER, ON EACH SIDE, bind off 4 sts. 1x, 3 sts. 6x (4 sts. 4x, 3 sts. 3x) After Row 166 (168), bind off the center 28 sts., put the needles on the left into holding position and complete the right side first. ON NECK SIDE, bind off 4 sts. 2x for both sizes. Bring the needles on the left into working position, knit 1 row in Pattern to the left side, turn the Row Counter back to 160 (162) and complete the left half. Follow the instructions from *.

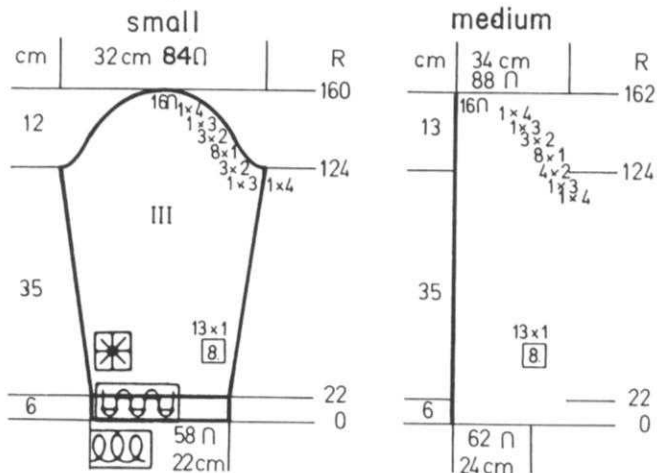
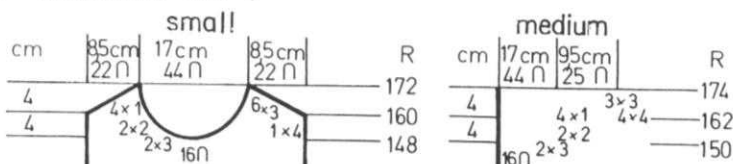

DK 1081

WOMAN'S PULLOVER & SKIRT

SIZE: 10/12
 YARN: Venetia
 GRAMS:
 color 1 1000
 color 2 100
 TENSION: 4.1 to 5 = Skirt
 3.1 to 4 = Pullover
 GAUGE: 14 1/2 sts. 26 rows = 5 cm
 (2") for Skirt
 18 sts. 26 rows = 5 cm (2")
 for Pullover

The Skirt is Stockinette stitch using Short Rows and is knitted sideways. The Pullover is a Tuck Stitch Pattern with Norwegian Border Designs. Bands are K1, P1 Ribbing.

FINISHING: See General Instructions. Make 2 Cords with color 1 16" long. Make Tassels with color 2 and sew to ends (See Picture). Sew cords in place.

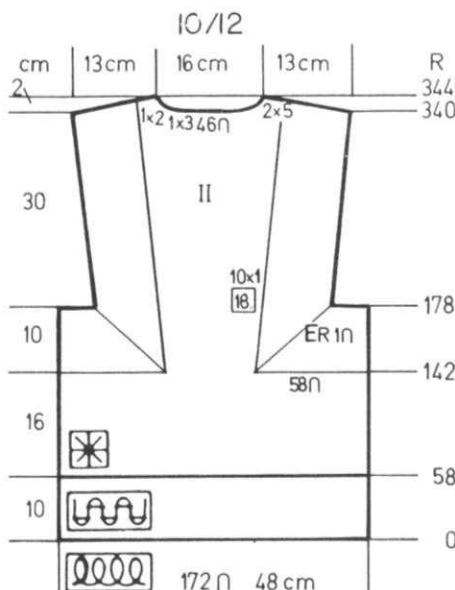
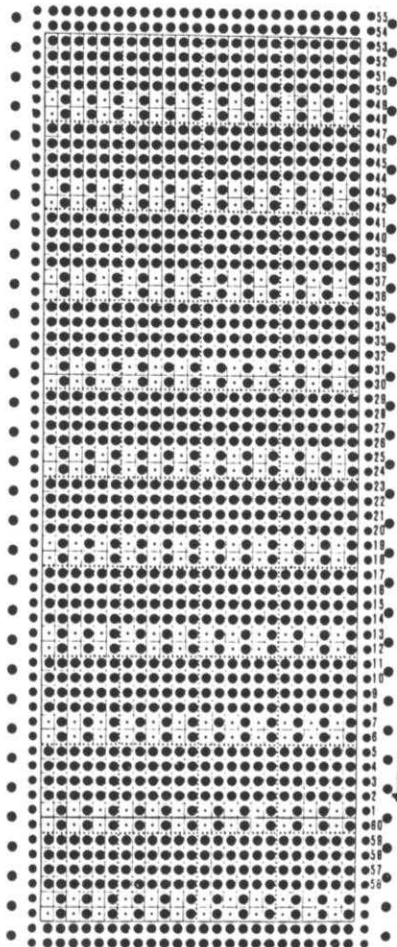
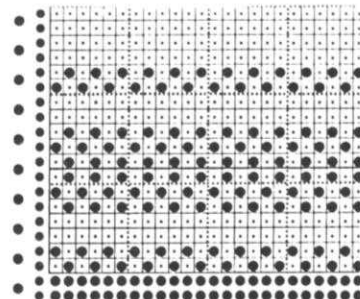
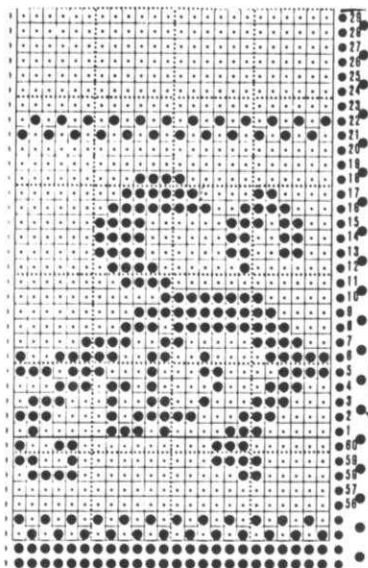

PULLOVER BACK: II

Cast on 172 sts. with color 1 and work 58 rows Ribbing. Transfer the Ribber sts. to main machine then work in Pattern 1 to Row 142. ON EACH SIDE, remove 58 sts. onto waste yarn and continue in Pattern over the remaining center sts. ON EACH SIDE, increase 1 st. every 18x row 10x. After Row 340, SHAPE NECK: Bind off the center 46 sts. Put the needles on the left into holding position and complete the right side first. *SHAPE SHOULDER AND NECK AT THE SAME TIME. FOR SHOULDER, bind off 5 sts. 2x. FOR NECK, bind off 3 sts. 1x, 2 sts. 1x. Bring the needles on the left into working position, knit 1 row in Pattern to the left side, turn the Row Counter back to 340 and complete the left half. Follow the instructions from *.

Pick up the 58 sts. held on waste yarn. Counter at 142. With color 2, knit 4 rows but SET PATTERN 2 after Row 3 and work Pattern with colors 2 and 1 BUT AT THE SAME TIME, ON INNER EDGE, decrease 1 st. EVERY ROW ending with 4 rows Stockinette stitch with color 2. After Row 178, bind off the remaining sts.

Pick up the stitches along front edge - 108 sts. Work the same as lower panel and ON INNER EDGE, decrease 1 st. EVERY ROW. After Row 38, bind off.

Work the other side the same way.

SLEEVE BANDS:

Cast on 64 sts. with color 1 and work 58 rows K1, P1 Ribbing. Transfer the Ribber sts. to the main machine then hang the open sts. of the sleeve onto the same needles, decreasing 50 sts. evenly across. Hang 2-2-2-3 etc. Bind off.

DK 1081

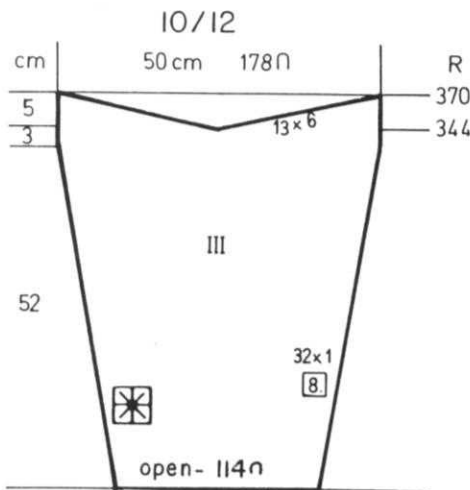

FRONT: I

Work the front the same as the back to Row 240. Bind off the center 6 sts., put the needles on the left into holding position and complete the right side first.

*ON NECK SIDE, bind off 3 sts. 1x, 2 sts. 2x, 1 st. 3x. INCREASE 1 st. every 5th row 8x. After Row 305, ON NECK SIDE, bind off 6 sts. 1x, 5 sts. 1x, 3 sts. 3x, 1 st. 3x AND SHAPE SHOULDER same as the back after Row 340.

Bring the needles on the left into working position, knit 1 row in Pattern to the left side, turn the Row Counter back to 240 and complete the left half. Follow the instructions from *.

Work the NORWEGIAN BANDS in Pattern 2 same as you did for the back.

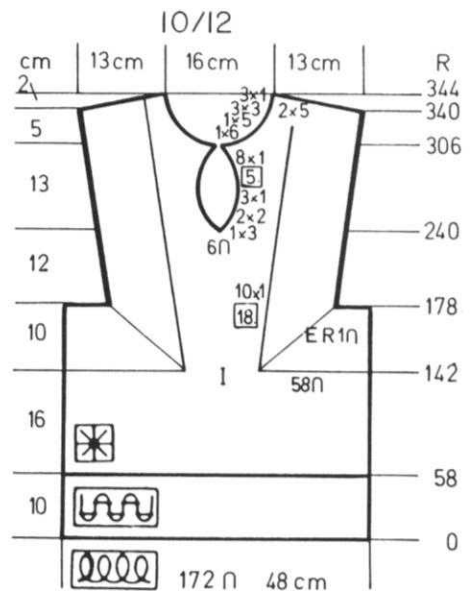

SLEEVES: III

OPEN CAST ON with contrast waste yarn. Cast on 114 sts. After knitting 9 to 11 rows, change to color 1 and work in Pattern 1. ON EACH SIDE, increase 1 st. every 8th row 32x. After Row 344, divide in the center. Put the needles on the left into holding position and complete the right side first. * ON INNER EDGE, bind off 6 sts. 13x. Bring the needles on the left into working position, knit 1 row in Pattern to the left side, turn the Row Counter back to 344 and complete the left half. Follow the instructions from *.

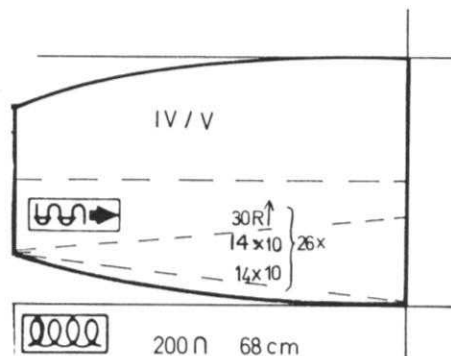

SKIRT: IV/V

Cast on 200 sts. with contrast waste yarn. Knit 9 to 11 rows then 1 row with a Ravel Cord to the right side. Change to color 1 and knit 10 rows.

*Begin SHORT ROWS. ON OPPOSITE SIDE OF CARRIAGE, put into holding position, 10 sts. 14x. Bring back into working position 10 sts. 14x.

Knit 30 rows over all needles. REPEAT FROM * 25.x more (26x in all).

End with 20 rows Stockinette stitch. Remove onto contrast waste yarn.

WAISTBAND: - Divide the waste in half, then pick up 120 sts. across half the skirt waist. With tension 3.2 knit 50 rows Stockinette stitch, hang the hem and bind off loosely - or you can bind off and sew band in half to the inside. Knit second half of band the same way. Press Skirt then weave the open sts. held on waste yarn and remove the waste yarn. Weave band seam on the outside then pull elastic through casing.

COLLAR:

Sew up shoulder seams first, then pick up 120 sts. around neckline. With color 2, (Ten.4) knit 4 rows Stockinette stitch. setting PATTERN 3 after Row 3. Continue in Pattern 3, changing the tension to 3.2 after Row 6, then 3.1 after Row 12. End with 4 rows Stockinette stitch with color 2. Bind off.

NECK OPENING BAND

Pick up 120 sts. around neck opening and with color 1, work 20 rows Stockinette stitch. Hang the hem, then bind off or you can bind off then turn band to the inside and sew in place. (See Picture).

DK 1082



WOMAN'S DRESS

SIZE: Medium
 YARN: Mohair & Boucle
 color 1 400
 color 2 250
 NO KIT AVAILABLE
 TENSION: 9 or 10
 GAUGE: 12 sts. 22 rows = 5 cm (2")

A Tuck stitch Pattern combined with Stockinette stitch. Knitted sideways on the machine. Punch your own Card and you can use the COLOR CHANGER. The purl side is the right side. Bands are Stockinette stitch.

FINISHING: See General Instructions. Turn under and sew hem in place on the sleeves. Sew Skirt to bodice and make hem at lower edge. Work 1 row single crochet down opening at back then sew in a zipper.

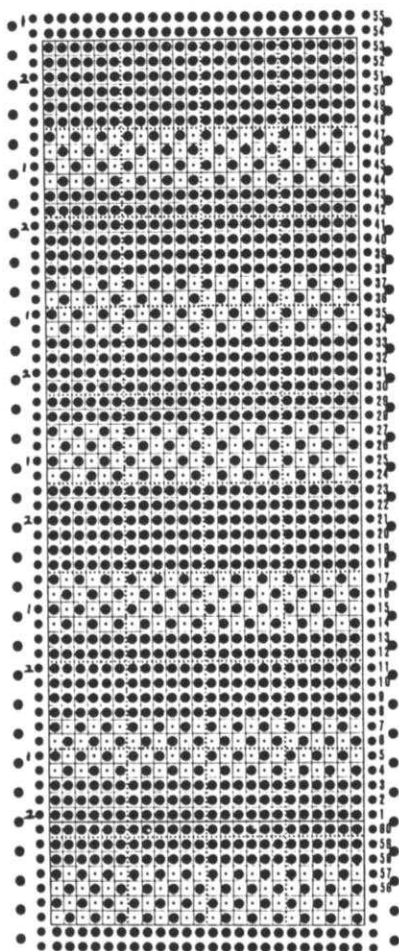

SKIRT:

Begin with contrast waste yarn same as you did for the Bodice. Cast on 168 sts. and work in Pattern to Row 570. Remove onto contrast waste yarn.

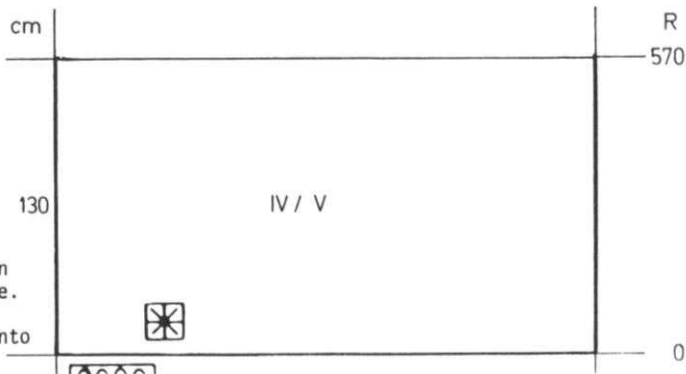

BODICE BACK: II

USE COLOR CHANGER
 To the extreme left side of machine cast on 26 sts. with contrast waste yarn. Knit 8 rows, then 1 row with Ravel Cord to the LEFT SIDE. Carriage on the LEFT. Put Counter at 0.

With color 1 and tension 6 or 7, knit 21 rows Stockinette stitch. Change to Tension 10 and knit 1 row, change to Tension 6 or 7 and knit to Row 44.

Change to Tension 9 or 10. With color 1, knit 5 rows Stockinette stitch. Carriage on RIGHT. Set KC, Card on STOP.

Knit 1 row RIGHT to LEFT. Push in BOTH TUCK BUTTONS. *Change to color 1, Knit 6 rows. REPEAT FROM * for PATTERN.

AT THE SAME TIME, on the right, increase 1 st. every 10th row 10x, every 8th row 10x, every 4th row 10x, every 2nd row 10x, then cast on 2 sts. 3x and after Row 292, cast on 28 sts.

Continue in Pattern to Row 344. ON NECK SIDE, bind off 1 st. 2x, 2 sts. 1x, 1 st. 1x. After Row 378, bind off 21 sts. at neck edge then cast them on again (or you can knit several rows BY HAND using waste yarn and remove the waste yarn later). This is slit for inserting zipper. After Row 404, ON NECK SIDE, cast on 1 st. 1x, 2 sts. 1x, 1 st. 2x. After Row 464, begin the SLEEVE DECREASES on the RIGHT, working in reverse.

NECKBAND:

Cast on 90 sts. and with Tension 7, knit 12 rows Stockinette stitch. Bind off or remove onto waste yarn.

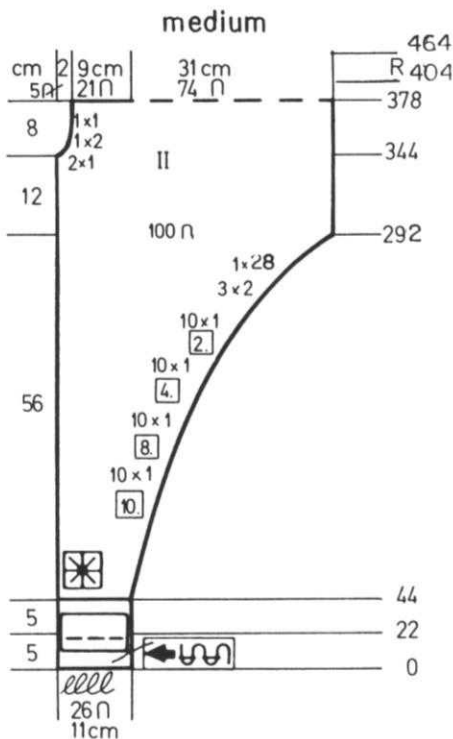

medium

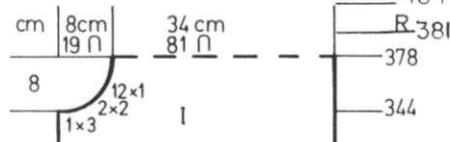

BODICE FRONT:

Work the front the same as the back EXCEPT FOR NECK SHAPING. After Row 344, ON NECK SIDE, bind off 3 sts. 1x, 2 sts. 2x, 1 st. 12x. Mark Row 378 for center of garment. After Row 382, ON NECK SIDE, cast on 1 st. 12x, 2 sts. 2x, 3 sts. 1x. After Row 464, begin the SLEEVE DECREASES on the RIGHT, working in REVERSE.

DK 1083



WOMAN'S COAT

SIZE: Medium
 YARN: Soft knitting worsted
 weight = color 1
 Chenille for weaving = color 2

GRAMS:
 color 1 800
 color 2 200

TENSION: 10 - EVERY OTHER NEEDLE
 GAUGE: 9 sts. 13 rows = 5 cm (2")

A Weaving Design. Punch your own Card. Knitted OVER EVERY OTHER NEEDLE. Worn on the Purl side. Bands are Stockinette stitch.

FINISHING: See General Instructions.

IMPORTANT - USE EVERY OTHER NEEDLE. THE OUT OF WORK NEEDLES ARE NOT COUNTED IN THE GAUGE OR THE INSTRUCTIONS.

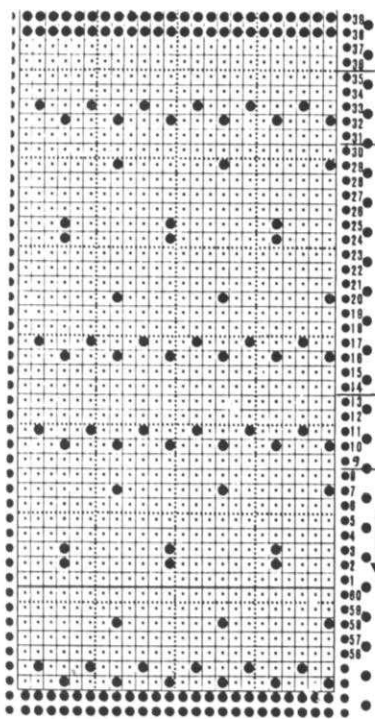

*2 Rows Weaving
 2 Rows Stockinette stitch
 1 Row Weaving
 3 Rows Stockinette stitch
 Hang strands of yarn onto selected needles.
 1 Row Stockinette stitch
 1 Row Weaving
 3 Rows Stockinette stitch
 Hang strands of yarn onto selected needles
 3 Rows Stockinette stitch
 2 Rows Weaving
 4 Rows Stockinette stitch
 REPEAT FROM *.

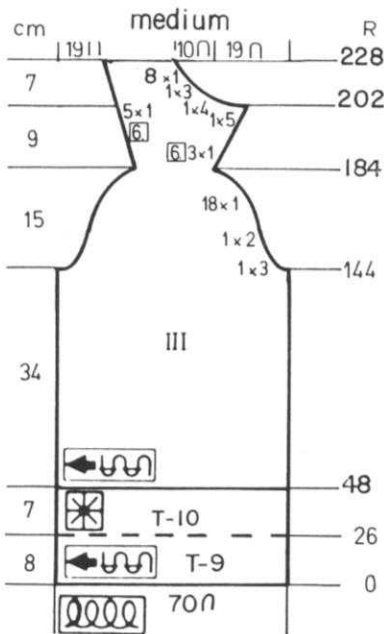

SLEEVES: III Make 1, reverse 1.

Cast on 70 sts. with color 1 OVER EVERY OTHER NEEDLE. Lower Tension and work 26 rows Stockinette stitch. Change to garment tension and continue in Pattern to Row 48. Continue in Stockinette stitch with color 1. After Row 144, SHAPE CAP: ON EACH SIDE, bind off 3 sts. 1x, 2 sts. 1x, then decrease 1 st. 18x. After Row 184, ON THE LEFT (right for second section), increase 1 st. every 6th row 5x and on the RIGHT (left) increase 1 st. every 6th row 3x. AT THE SAME TIME, after Row 202, ON THE RIGHT (left) bind off 5 sts. 1x, 4 sts. 1x, 3 sts. 1x, 1 st. 8x. After Row 228, bind off the remaining sts.

FRONT BANDS: Make 2.

Cast on 8 (every other needle) leave 2 needles out of work then cast on 8 more sts. the same way. With color 1, knit 286 rows. Sew 1 half of band to inside and 1 to the outside of front edges.

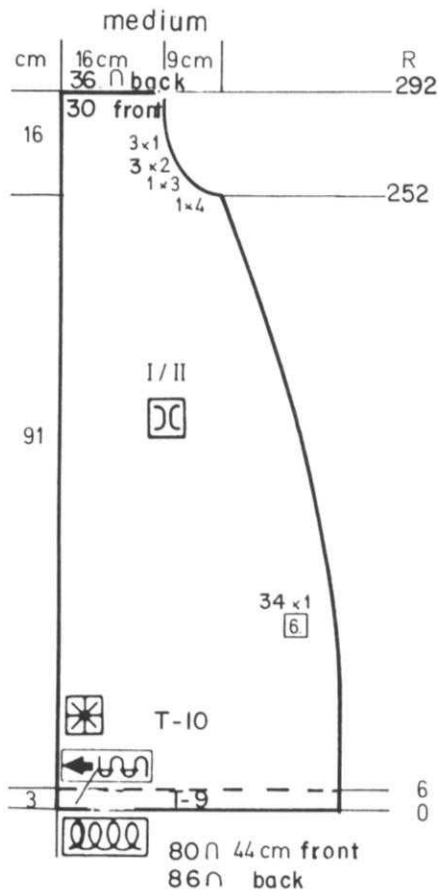

FRONT & BACK: I/II
 Knit 2 and REVERSE 2.
 The SHAPINGS are the same for front and back - ONLY THE NUMBER FOR THE CAST ON STS. are different.

Cast on 86 sts. for BACK with color 1. Cast on 80 sts. for FRONT with color 1. OVER EVERY OTHER NEEDLE. Lower Tension 1 number and knit 6 rows Stockinette stitch. Change Tension to garment tension and continue in Pattern. ON SIDE EDGE, decrease 1 st. every 6th row 34x. After Row 252, SHAPE ARMHOLE: Bind off 4 sts. 1x, 3 sts. 1x, 2 sts. 3x, 1 st. 3x. After Row 292, bind off the remaining sts.

Make another section the same and two more sections with REVERSE shapings.

COLLAR:

Cast on 86 sts. OVER EVERY OTHER NEEDLE and work Stockinette stitch. Lower Tension and knit 18 rows. Change to garment tension and knit 18 rows. Bind off. Sew smaller tension half to the inside and other half to outside of neckline.

DK 1084



WOMAN'S LACE PULLOVER

SIZES 6 (8/10)
 YARN: Beatrice Silver
 GRAMS: 300 350
 TENSION: 5 to 7
 GAUGE: 14 1/2 sts. 20 rows = 5 cm (2")

A Lace Design with bands in K1, P1 Ribbing. Punch your own Card.

FINISHING: See General Instructions.

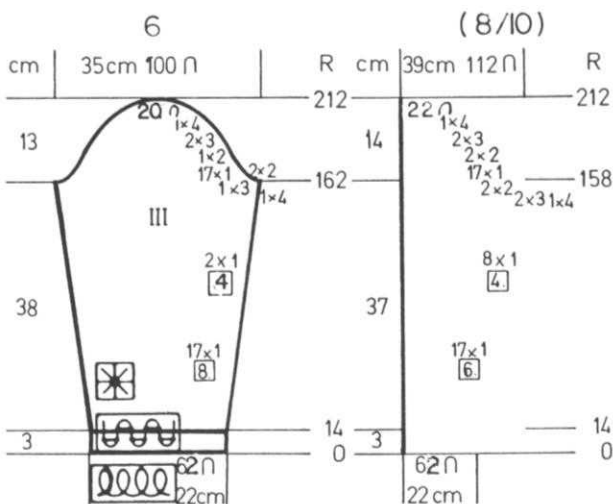
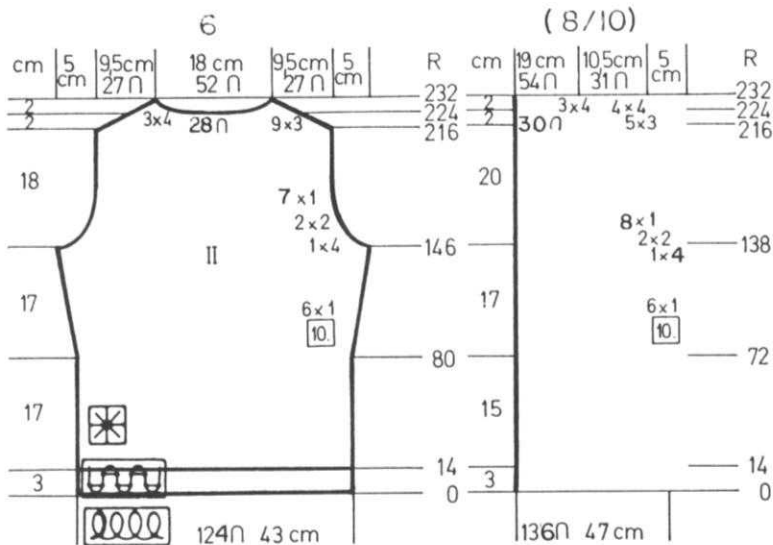
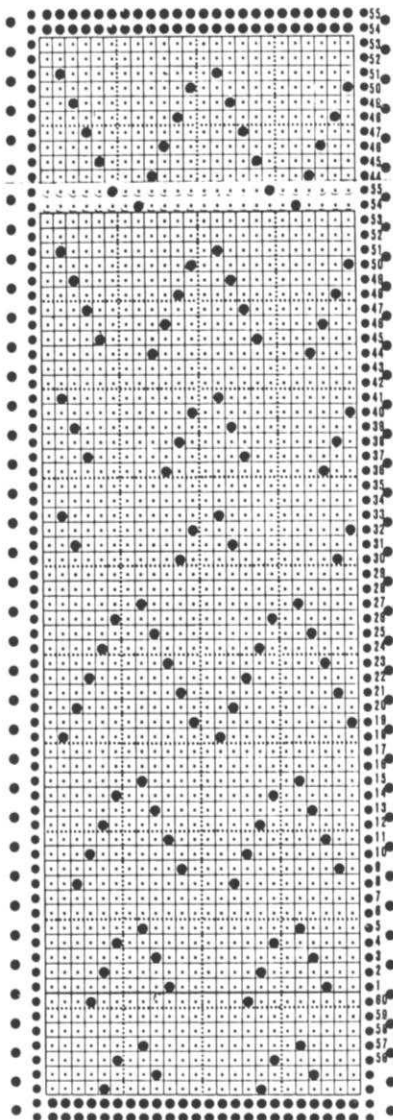

SLEEVES: III

Cast on 62 sts. and work 14 rows K1, P1 Ribbing. Continue in Pattern. ON EACH SIDE, increase 1 st. every 8th row 17x, every 4th row 2x. (every 6th row 17x, every 4th row 8x). After Row 162 (158), SHAPE CAP: Please follow the Chart in your size for the bind-offs ON EACH SIDE. After Row 212, bind off the remaining sts.

NECKBAND: Make 2.

Cast on 115 (121) sts. and work 14 rows K1, P1 Ribbing. Bind off or remove onto contrast waste yarn.

(8/10)

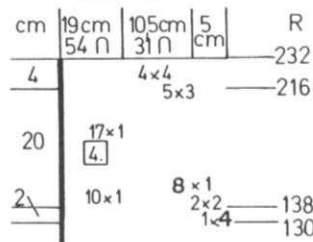
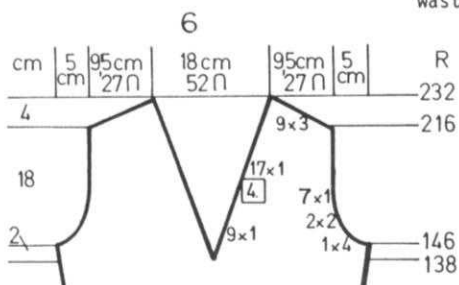

BACK: II

Cast on 124 (136) sts. and work 14 rows K1, P1 Ribbing. Continue in Lace Pattern. After Row 80 (72), ON EACH SIDE increase 1 st. every 10th row 6x. After Row 146 (138), SHAPE ARMHOLE: ON EACH SIDE, bind off 4 sts. 1x, 2 sts. 2x, 1 st. 7x. (4 sts. 1x, 2 sts. 2x, 1 st. 8x). After Row 216, SHAPE SHOULDER and WATCH FOR NECK SHAPING. FOR SHOULDER, ON EACH SIDE, bind off 3 sts. 9x (3 sts. 5x, 4 sts. 4x) AT THE SAME TIME, after Row 224, bind off the center 28 (30) sts., put the needles on the left into holding position and complete the right side first. *ON NECK SIDE, bind off 4 sts. 3x. Bring the needles on the left into working position, knit 1 row in Pattern to the left side, turn the Row Counter back to 224 and complete the left half. Follow the instructions from * and don't forget to complete the shoulder shaping.

FRONT: I

Work the front the same as the back to Row 138 (130). Divide in the center, put the needles on the left into holding position and complete the right side first. *ON NECK SIDE, decrease 1 st. 9x (10x) then every 4th row decrease 1 st. 17x. AT THE SAME TIME, after Row 146 (138) SHAPE ARMHOLE same as the back. After Row 216, SHAPE SHOULDER same as the back. Bring the needles on the left into working position, knit 1 row to the left side (watch Pattern) and complete the left half. Follow the instructions from *.

DK 1085



WOMAN'S PULLOVER

SIZES: 10 (12) [14/16]
 YARN: Fortissima
 GRAMS: 350 400 400
 TENSION: 7
 GAUGE: 12 sts. 16 1/2 rows = 5 cm (2")

A Lace Pattern. Bands are K1, P1 Ribbing. Punch your own Card.

FINISHING: See General Instructions.

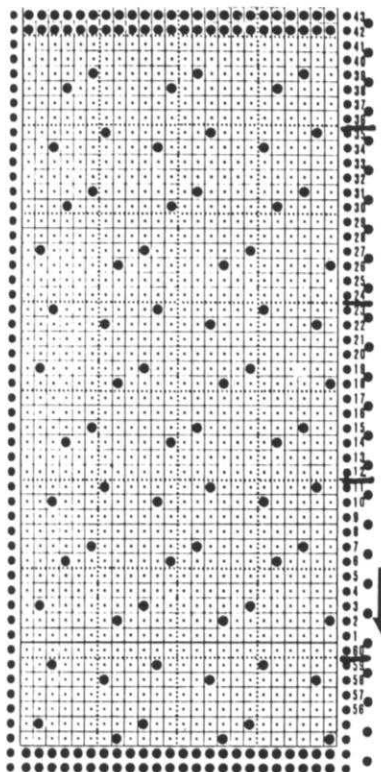

1085

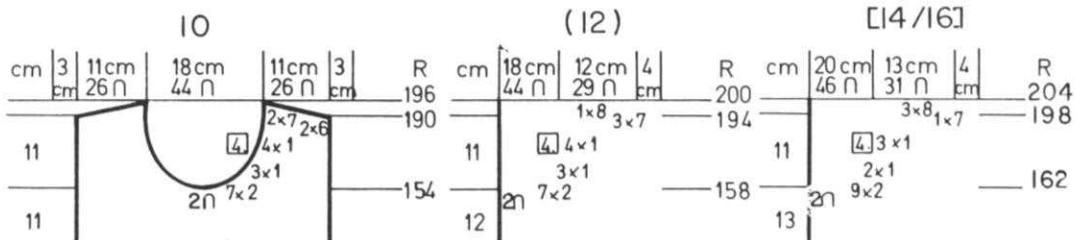

COLLAR:

Cast on 11 sts. and work K1, P1 Ribbing. Have 2 sts. on the main machine at each end.
 ON EVERY 4th ROW, increase 1 st.
 ON EACH SIDE 4x (make the increases between 2nd and 3rd sts. on each end).
 Knit 22 rows even.
 ON EACH SIDE, decrease 1 st. every 4th row 4x (work decreases between 2nd and 3rd sts. on each end).
 Knit 30 rows.
 ON EACH SIDE, increase 1 st. every 4th row 4x same as you did before.
 Knit over the 19 sts. for 100 (110) rows.
 This is the center of back. Work the second half IN REVERSE.
 Work single crochet around neck edge then sew on collar leaving 3 cm open at front edges.

FRONT: I

Work the front the same as the back to Row 154 (158) [162]. Bind off the center 2 sts., put the needles on the left into holding position and complete the right side first.
 *ON NECK SIDE, bind off 2 sts. 7x, 1 st. 3x, 1 st. every 4th row 4x.
 (Same as first size.)
 [2 sts. 8x, 1 st. 2x, 1 st. every 4th row 3x.
 After Row 190 (194) [198], SHAPE SHOULDER same as the back.
 Bring the needles on the left into working position, knit 1 row to the left side (watch Pattern) and complete the left half. Follow the instructions from *.

BACK: II

Cast on 110 (122) [128] sts. and work 36 rows K1, P1 Ribbing. Continue in Lace Pattern.
 AFTER ROWS 12, 24, 36, 60 ON THE PUNCH CARD, KNIT 4 ROWS BEFORE USING LACE CARRIAGE AGAIN.
 After Row 118 (118) [120], ON EACH SIDE, bind off 7 (10) [10] sts. Knit in Pattern to Row 190 (194) [198].
 Bind off the center 24 (24) [22] sts., put the needles on the left into holding position and complete the right side first.
 *SHAPE SHOULDER AND NECK AT THE SAME TIME.
 FOR SHOULDER, bind off 6 sts. 2x, 7 sts. 2x (7 sts. 3x, 8 sts. 1x) [7 sts. 1x, 8 sts. 3x].
 FOR NECK, bind off 5 (5) [6] sts. 2x.
 Bring the needles on the left into working position, knit 1 row to the left side, turn the Row Counter back to 190 (194) [198] (WATCH PATTERN) and complete the left half. Follow the instructions from *.

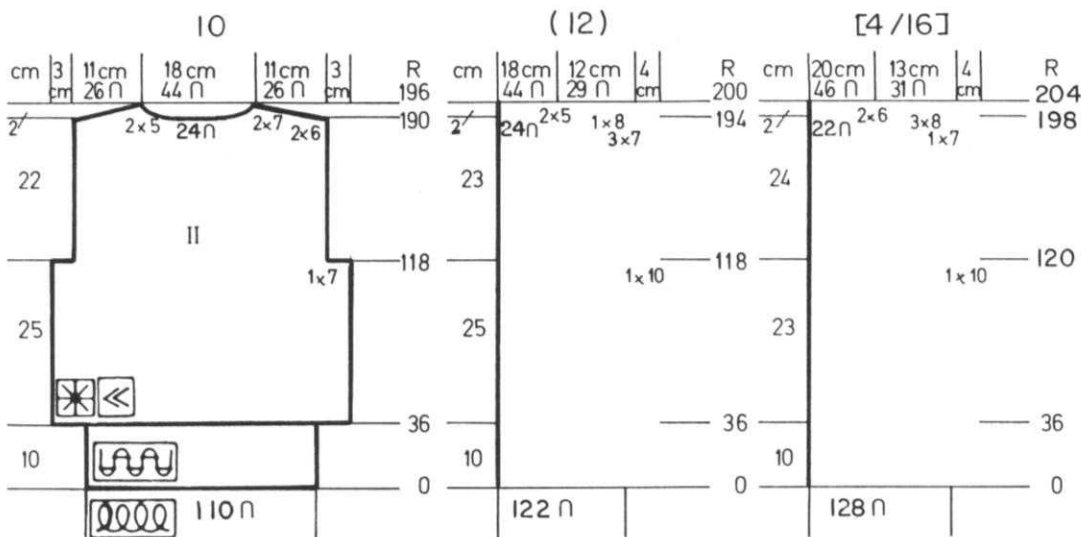

DK 1085

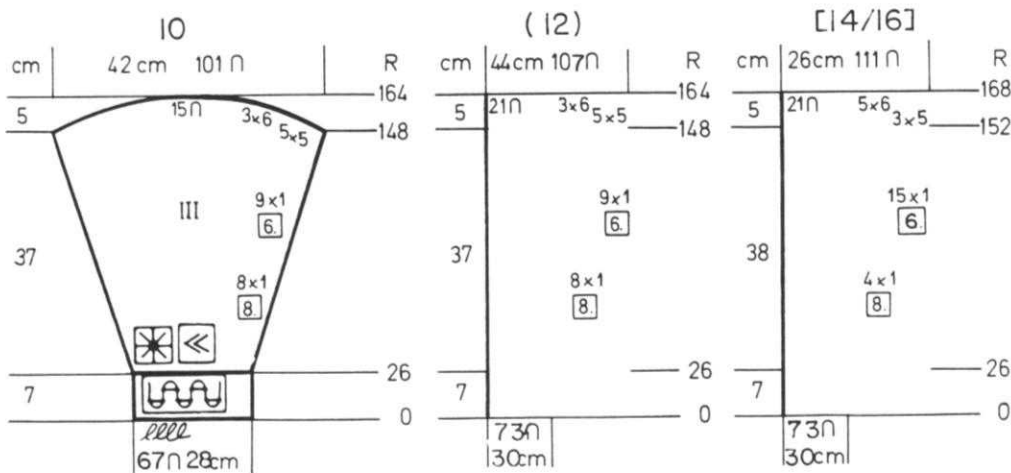

SLEEVES: III

Cast on 67 (73) [73] sts. and work 26 rows K1, P1 Ribbing. Continue in Pattern same as back and front.
ON EACH SIDE, increase 1 st. every 8th row 8x (8x) [4x] every 6th row 9x (9x) [15x]. After Row 148 (148) [152], SHAPE CAP: Please follow the bind-offs ON EACH SIDE as shown on the Chart for your size. After Row 164 (164) [168], bind off the remaining sts.

DK 1086

WOMAN'S JACKET & SKIRT

SIZE 10/12
YARN: Venetia & Amore
GRAMS:
color 1 550 = Venetia
color 2 50 = Amore
color 3 100 = Amore
color 4 100 = Amore
TENSION: 4 to 6
GAUGE: 19 sts. 26 rows = 5 cm (2")



A Norwegian Design for the Jacket. The Skirt is Ribbed. Sleeve bands are K2, P2 Ribbing.

FINISHING: See General Instructions.

JACKET BACK: II

NOTE: There are 3 different Patterns used and in between each pattern, you must knit 31 rows Stockinette stitch with color 1, then SET SPECIFIED PATTERN BEFORE knitting the next Row to the right. After each Pattern, RELEASE ALL BUTTONS and knit the 31 rows required. Each Punch Card will give you the required Row Number for setting and the colors to use. Cast on 190 sts. with color 1 and knit 10 rows Stockinette st. (SET PATTERN C - LINE 37 on Card. after Row 9). With colors 3 & 4, work Pattern C. Hang Hem. Stop Card and work 32 rows Stockinette st. then work Pattern A with colors 3 and 2 (line 1 on Card). Work the 31 rows Stockinette st. with color 1. Work Pattern B with colors 2 and 3 (Set Card on Line 19) Knit the 31 Rows Stockinette with color 1, then begin again with Pattern C. REPEAT Patterns in sequence. After Row 356, bind off.

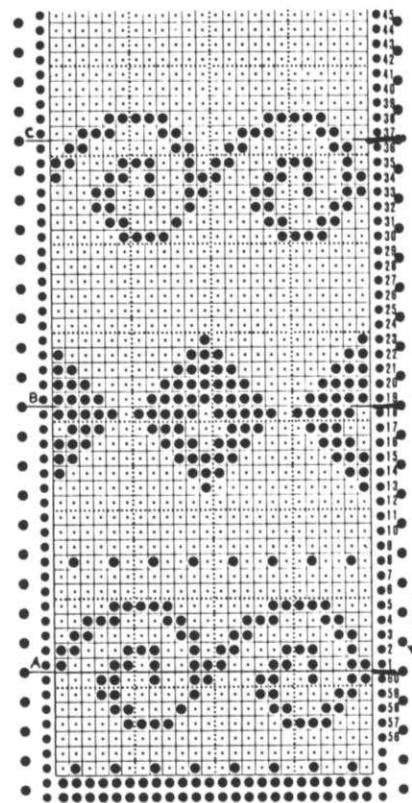
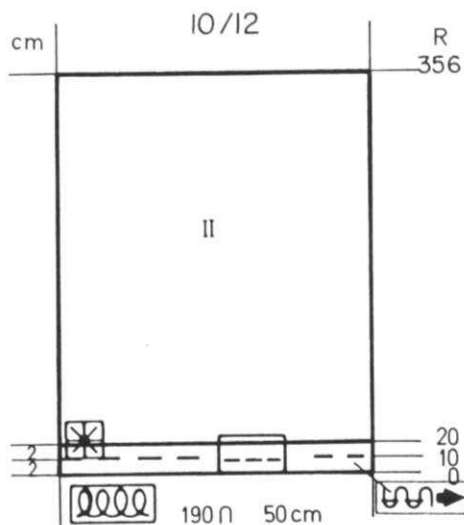

ALWAYS KNIT 31 ROWS STOCKINETTE STITCH BETWEEN PATTERNS, THEN SET PATTERN ON NEXT ROW. RELEASE ALL BUTTONS WHEN PATTERN IS COMPLETED THEN SET IT AGAIN FOR NEXT PATTERN.

PATTERN A = Colors 3 & 2. Set Card on Line 1. (15 Rows)

PATTERN B = Colors 2 & 3. Set Card on Line 19. (11 Rows)

PATTERN C = Colors 3 & 4. Set Card on Line 37. (9 Rows)

DK 1086

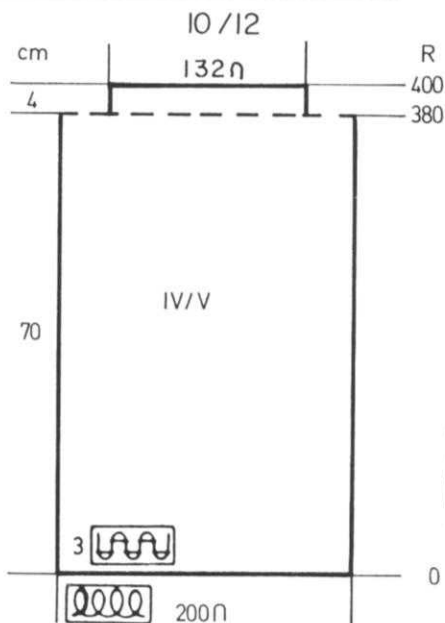

SKIRT: IV/V Make 2 sections the same.

Color 1.
RIBBER CAST ON 200 sts. each bed.
After the 4 rows for cast on,
set into Rib Pattern as follows:
7 sts. on the main machine, 3 sts.
on the Ribber and REPEAT across.
Knit to Row 380.
Transfer the Ribber sts. to main
machine, knit 1 row stockinette
st. then remove onto contrast
waste yarn.
Hang the sts. back onto the
machine, decreasing to 132 sts.
Hang 2-1-2-1 etc. across.
Knit 20 rows then bind off.

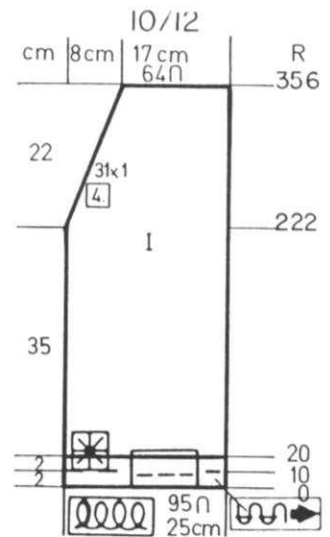

FRONT: I Make 1, reverse 1

Cast on 95 sts. with color 1
and WORK THE SAME AS THE BACK.
After Row 222, ON NECK SIDE,
decrease 1 st. every 4th row 31x.
After Row 356, bind off.

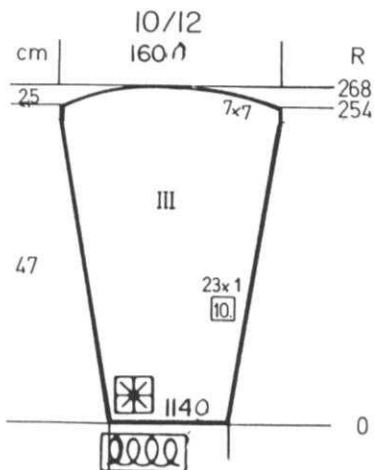

SLEEVES: III

OPEN CAST ON 114 sts. with contrast
waste yarn. Knit 9 to 11 rows,
then 1 row with ravel cord to the
right side.
After Ravel Cord Row, change to
color 1 and set Counter at 0.
Knit 2 rows, setting Pattern
A before knitting Row 2.
Continue in Pattern same as the back
and front.
ON EACH SIDE, increase 1 st.
every 10th row 23x.
After Row 254, ON EACH SIDE,
bind off 7 sts. 7x. After
Row 268, bind off the remaining sts.

FRONT BANDS: Make 2.

With color 4 and Ribber, cast
on 200 sts. on both beds.
Work 10 Rows K2, P2 Ribbing.
Transfer the Ribber sts. to
main machine then hang 1 front onto
these needles and bind off.

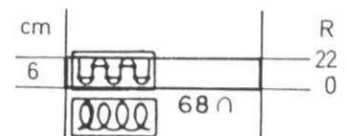

SLEEVE BANDS: Make 2.

With color 4 and Ribber, cast on
68 sts.
Work 22 Rows K2, P2 Ribbing then
hang the open sts. of the sleeve
onto these needles. Hang 2-2-1-
2-2-1 etc. Bind off.

DK 1087

WOMAN'S THREE PIECE SUIT

SIZE: 6
YARN: Venetia plus fine yarn for Plating.

GRAMS:
color 1 850 = Venetia
color 2 250 = Fine yarn
TENSION: 7 to 8 for Jacket
3.2 to 4 for Pullover
3/3 for Skirt (Use Ribber)

GAUGE:
Jacket -16 sts. 20 rows = 5 cm
Pullover -17 sts. 25 rows = 5 cm
Skirt - 20 sts. 24 rows = 5 cm

The Jacket is Plated, the Skirt a Ribbing Pattern. The Pullover is Stockinette stitch with K2,P2 bands. Bands for Jacket are Stockinette stitch with color 1.

FINISHING: See General Instructions.

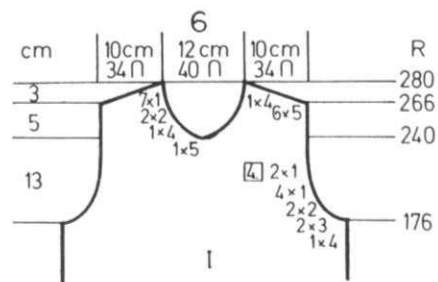

FRONT: I

Work the front the same as the back to Row 176.
SHAPE ARMHOLE same as the back then knit to Row 240.
Divide in the center, put the needles on the left into holding position and complete the right side first.
*ON NECK SIDE, bind off 5 sts. 1x, 4 sts. 1x, 2 sts. 2x, 1 st. 7x.
After Row 266, SHAPE SHOULDER same as the back.
Bring the needles on the left into working position, knit 1 row to the left side, turn the Row Counter back to Row 240 and complete the left half. Follow the instructions from *.

PULLOVER BACK: II

Cast on 148 sts. with color 1 and work K2, P2 Ribbing with Ten.3/3 to Row 40. Change to Tension 4. Continue in Stockinette stitch.
After Row 176, SHAPE ARMHOLE: ON EACH SIDE, bind off 4 sts. 1x, 3 sts. 2x, 2 sts. 2x, 1 st. 4x, 1 st. every 4th row 2x.
After Row 266, SHAPE SHOULDER and WATCH FOR NECK SHAPING.
FOR NECK SHAPING.
FOR SHOULDER, bind off 5 sts. 6x, 4 sts. 1x.
FOR NECK: After Row 274, divide in the center, put the needles on the left into holding position and complete the right side first.
*ON NECK SIDE, bind off 7 sts. 2x, 6 sts. 1x.
Bring the needles on the left into working position, knit 1 row to the left side, turn the Row Counter back to 274 and complete the left half.
Follow the instructions from *.

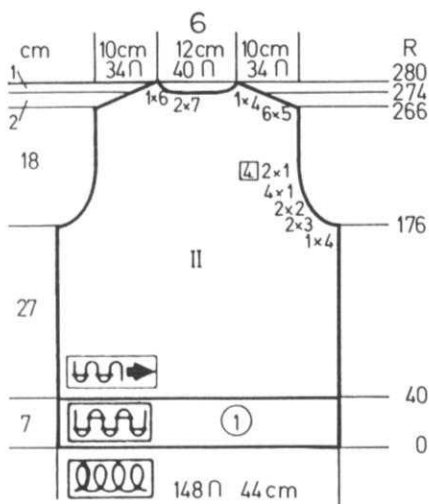

PULLOVER NECKBAND:

Cast on 130 sts. with color 1 and work 10 row K2 P2 Ribbing with Tension 3.
Work 4 rows circular knitting then remove onto contrast waste yarn.
Sew 1 edge to inside and 1 edge to outside of neckline and remove the waste yarn.

CANADIAN READERS PLEASE NOTE

A company named Nan Lynch Distributing of 2180 Yonge St., Toronto, Canada is not an authorized dealer for KNITKING brand knitting machines and other KNITKING brand products and it does not have authority from KNITKING Corporation to use the KNITKING LOGO on its letter heading.

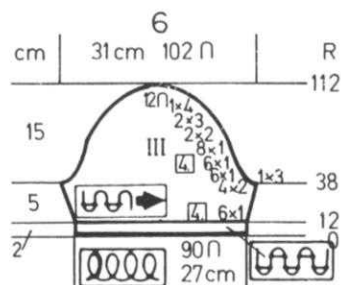

SLEEVES: III

Cast on 90 sts. with color 1 and work 12 rows K2, P2 Ribbing. Continue in Stockinette stitch.
ON EACH SIDE, increase 1 st. every 4th row 6x.
After Row 38, SHAPE CAP: ON EACH SIDE, bind off 3 sts. 1x, 2 sts. 4x, 1 st. 6x, 1 st. every 4th row 6x, then 1 st. 8x, 2 sts. 2x, 3 sts. 2x, 4 sts. 1x. After Row 112, bind off the remaining sts.

DK 1087

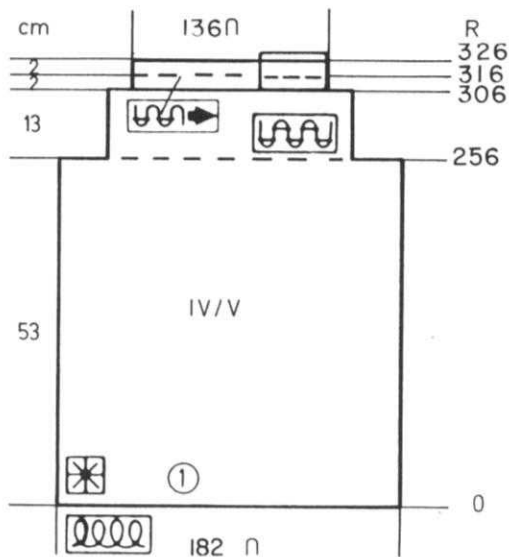

SKIRT: IV/V Make 2 sections the same.

Cast on 182 sts. with color 1 and set into Rib Pattern as follows:

*4 sts. on main machine, 2 sts. on Ribber, 2 sts. on main machine, 2 sts. on Ribber, 2 sts. on main machine, 2 sts. on Ribber, 4 sts. on main machine 2 sts. on Ribber. REPEAT from * across. Knit to Row 256.

Remove the sts. on to contrast waste yarn.

Hang the sts. back onto the machine as follows:

*2 sts. on first needle (pull each doubled st. through the first st. because you will transfer for Ribbing.

1 st. on next 2 needles, 2 sts. on next needle, 1 st. on next 2 needles. REPEAT FROM * across.

Transfer every other st. to the Ribber and work K1, P1 Ribbing to Row 306.

Transfer the Ribber sts. to main machine and work Stockinette stitch to Row 326 then hang the hem, picking up first row of Stockinette stitch and bind off loosely.

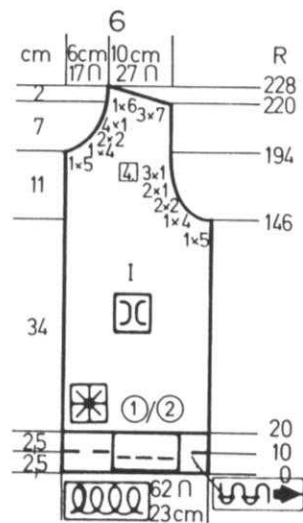

FRONT: I

Cast on 62 sts. with color 1 and work Stockinette stitch to Row 20.

Continue with Plating using colors 1 and 2.

After Row 146, SHAPE ARMHOLE same as the back and after Row 193, SHAPE NECK.

Bind off 5 sts. 1x, 4 sts. 1x, 2 sts. 2x, 1 st. 4x and after Row 220, SHAPE SHOULDER same as the back.

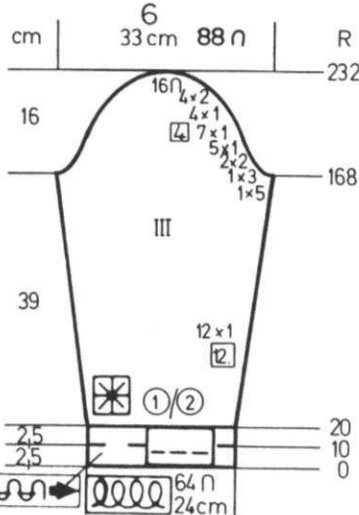

SLEEVES: III

Cast on 64 sts. with color 1 and work 20 rows Stockinette stitch.

Continue in Plating with colors 1 and 2.

ON EACH SIDE, increase 1 st. every 12th row 12x.

After Row 168, SHAPE CAP:

Bind off 5 sts. 1x, 3 sts. 1x, 2 sts. 2x, 1 st. 5x, 1 st. every 4th row 7x, then 1 st. 4x, 2 sts. 4x. After Row 232, bind off the remaining sts.

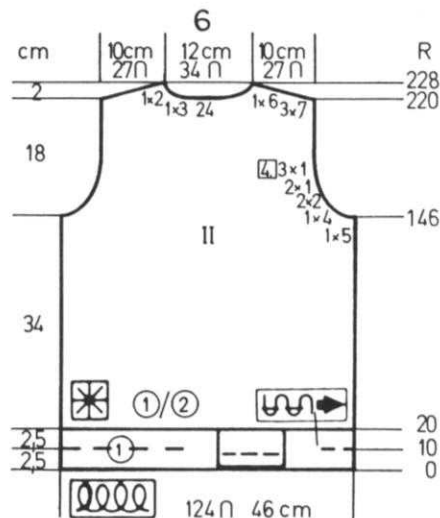

JACKET BACK: II

Cast on 124 sts. with color 1 and work Stockinette stitch to Row 20. Continue with Plating using colors 1 and 2.

After Row 146, SHAPE ARMHOLE: ON EACH SIDE, bind off

5 sts. 1x, 4 sts. 1x, 2 sts. 2x, 1 st. 2x, then 1 st. every 4th row 3x.

After Row 220, bind off the center 24 sts., put the needles on the left into holding position and complete the right side first.

*SHAPE SHOULDER AND NECK AT THE SAME TIME.

FOR SHOULDER, bind off 7 sts. 3x, 6 sts. 1x.

FOR NECK, bind off 3 sts. 1x, 2 sts. 1x.

Bring the needles on the left into working position, knit 1 row to the left side, turn the Row Counter back to 220 and complete the left half. Follow the instructions from *.

FRONT BANDS:

Sew side and shoulder seams FIRST. Turn under 10 rows at lower edge and hem to the wrong side.

Hang 1 edge of front back onto the machine with wrong side facing you - 110 sts.

With color 1 and tension 3, work 20 rows Stockinette stitch. Bind off loosely.

REPEAT for other side. Turn band to the wrong side and hem in place.

NECKBAND:

Hang the sts. for the neck back onto the machine with wrong side facing you - 84 sts.

With color 1 and tension 3, work 20 rows Stockinette stitch. Bind off loosely. Turn the band to the wrong side and hem in place.

DK 1088

WOMAN'S PULLOVER

SIZE: 8
 YARN: Sport weight
 GRAMS:
 color 1 600
 color 2 50
 color 3 50
 color 4 50
 NO KIT AVAILABLE
 TENSION: 8 or 9
 GAUGE: 12 sts. 16 rows = 5 cm (2")

An Intarsia Design with
 Stockinette stitch.
 Bands are K2, P2 Ribbing.

FINISHING: See General Instructions.

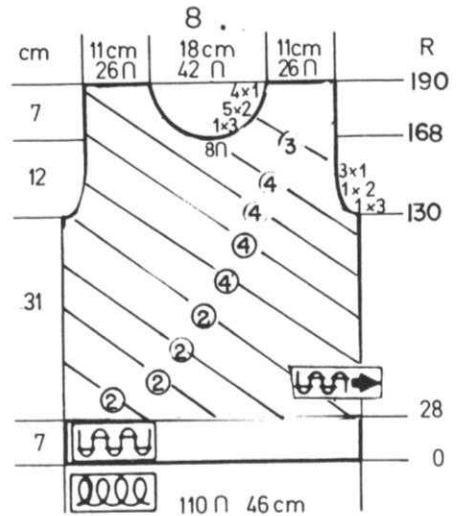

FRONT: I

Cast on 110 sts. with color 1 and work 28 rows K2, P2 Ribbing. Transfer the Ribber sts. and work the INTARSIA DESIGN. Count from the RIGHT SIDE, 6 sts. color 1, 2 sts. color 2, 24 sts. color 1, 2 sts. color 2, 24 sts. color 1, 2 sts. color 2, 24 sts. color 1, 2 sts. color 2, 24 sts. color 1, 2 sts. color 2, 24 sts. color 1, ON EVERY ROW, MOVE the design (ALL STS.) 1 st. to the LEFT (See Picture). CHANGE COLORS AS SHOWN ON THE CHART.

After Row 130, SHAPE ARMHOLE: ON EACH SIDE, bind off 3 sts. 1x, 2 sts. 1x, 1 st. 3x. After Row 146 and 168, continue the 2 sts. of diagonal design with color 3. After Row 168, bind off the center 8 sts. and put the needles on the left into holding position and complete the right side first. *ON NECK SIDE, bind off 3 sts. 1x, 2 sts. 5x, 1 st. 4x. After Row 190, bind off (or remove onto waste yarn) the remaining sts. Bring the needles on the left into working position, knit 1 row to the left side, turn the Row Counter back to 168 and complete the left half. Follow the instructions from *.

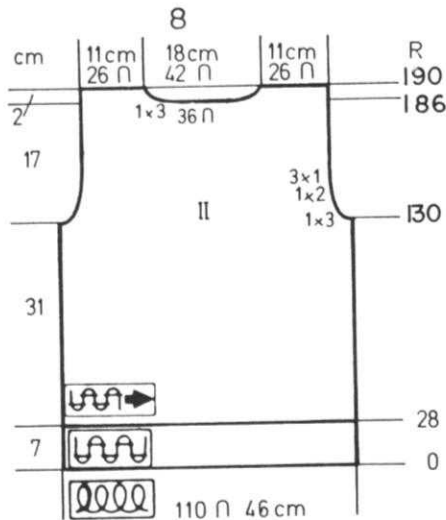

BACK: II

The back is worked all in Stockinette stitch after the ribbing using color 1. Cast on 110 sts. and work Ribbing same as front. Continue in stockinette stitch with color 1. After Row 130, SHAPE ARMHOLE SAME AS THE BACK. After Row 186, bind off the center 36 sts., put the needles on the left into holding position and complete the right side first. *ON NECK SIDE, bind off 3 sts. 1x. After Row 190, bind off. Bring the needles on the left into working position, knit 1 row to the left side and complete the left half. Follow the instructions from *.

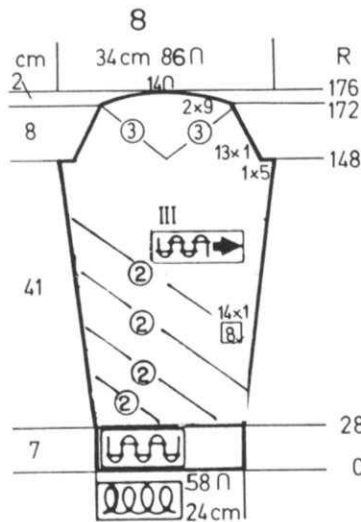

SLEEVES: III

Cast on 58 sts. and work K2, P2 Ribbing to Row 28. Transfer the Ribber sts. and set up the Intarsia Pattern same as the front - 6 sts. color 1, 2 sts. color 2, *24 sts. color 1, and REPEAT from * 1x. Work the Intarsia Design same as the front with color as shown on the Chart.

ON EACH SIDE, increase 1 st. every 8th row 14x. After Row 148, SHAPE CAP: ON EACH SIDE, bind off 5 sts. 1x, then 1 st. every 2nd row 13x BUT AT THE SAME TIME, work the Intarsia Design as shown on the Chart with color 3. After Row 172, ON EACH SIDE, bind off 9 sts. 2x. After Row 176, bind off the remaining sts.

NECKBAND:

Cast on 136 sts with color 1 and work 24 rows K2, P2 Ribbing. Bind off or remove onto contrast waste yarn.

DK 1089



WOMAN'S PULLOVER

SIZES: 10/12

YARN: Amore

GRAMS:

color 1 150

color 2 100

color 3 100

color 4 100

color 5 50

TENSION: 5 or 6

GAUGE: 14 sts. 22 rows = 5 cm (2")

Knitted sideways on the machine with an INTARSIA DESIGN. Follow the Chart for the design and color changes. Bands are K1, P1 Ribbing.

FINISHING: See General Instructions.

WAISTBAND: Make 2.

Cast on 102 sts. with color 4 and work 38 rows K1, P1 Ribbing. Transfer the Ribber sts. to main machine then hang one edge of waist onto the needles, evenly spaced across. Bind off.

NECKBAND:

Cast on 112 sts. with color 4 and work 10 rows K1, P1 Ribbing. Remove onto contrast waste yarn. Sew shoulder seams, then sew neckband in place.

CUFFS: Make 2.

Cast on 62 sts. with color 4 and work 30 rows K1, P1 Ribbing. Transfer the Ribber sts. to main machine, then hang 1 edge of sleeve to these needles and bind off. (Be sure to sew sleeve and shoulder seams first).

BACK: II

To the extreme RIGHT side of machine, cast on 40 sts. with waste yarn same as you did for the front.

Knit with the Ravel Cord from RIGHT to LEFT, then PUT COUNTER at 0 on the LEFT SIDE.

Work the back the same as the front but WITHOUT the Intarsia Design. Put in the Stripes on the correct rows as before and make the increases same as for the FRONT.

After Row 251, SHAPE NECK. Bind off 2 sts. 1x, 1 st. 1x.

Knit to Row 292. Mark for center of back same as you did for the front then work the second half with REVERSE SHAPINGS. Remove onto contrast waste yarn.

10/12

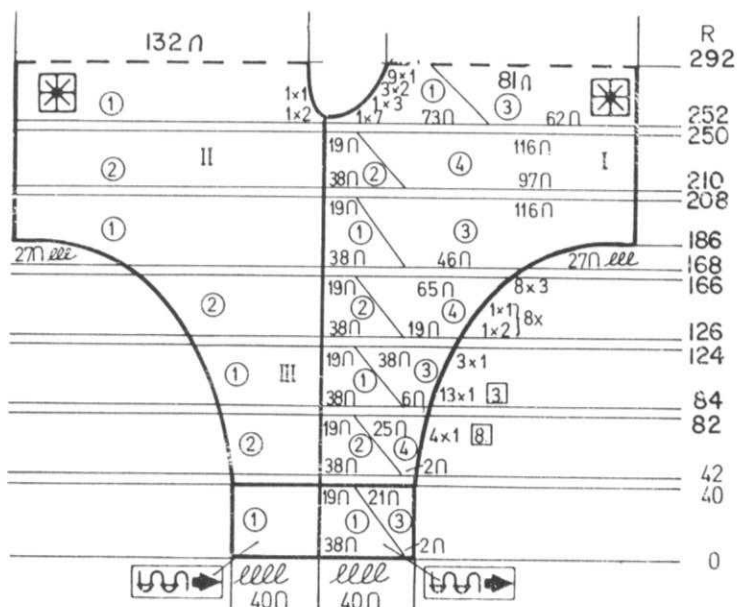

FRONT: I

To the extreme left side of machine, cast on 40 sts. using contrast waste yarn. Knit 9 rows, 1 row with ravel cord to the right side.

Counter at 0 and begin the INTARSIA DESIGN, beginning with 2 sts. color 3 and 38 sts. color 1. ON EVERY 2nd ROW, move the color over 1 stitch as shown on the Chart.

AFTER ROW 40 and all the following single color stripes, knit 2 rows color 5.

Continue to follow the INTARSIA DESIGN as shown on the Chart AND AT THE SAME TIME, after Row 42, ON THE RIGHT SIDE, increase 1 st. every 8th row 4x, every 3rd row 13x.

After Row 126, ON THE RIGHT, increase 1 st. every 2nd row 3x, then *Cast on 2 sts. 1x, 1 st. 1x and REPEAT from * 8x IN ALL.

After Row 168, cast on 3 sts. 8x, then cast on 27 sts.

Continue to follow Chart and after Row 251, ON NECK SIDE, bind off 7 sts. 1x, 3 sts. 1x, 2 sts. 3x, 1 st. 9x.

MARK ROW 292 for center of garment, the work the second half of front with REVERSE SHAPING (see picture). Remove onto contrast waste yarn.

HP 1090



MAN'S SLEEVELESS PULLOVER

SIZES: 38 (40)
 YARN: Nomotta Viola
 GRAMS:
 color 1 200 250
 color 2 100 100
 color 3 100 100

NO KIT AVAILABLE

TENSION: 10

GAUGE: 12 1/2 sts. 17 rows = 5 cm (2")

Stockinette stitch with color stripes.
 Worn on the pur1 side. Bands are
 K1, P. Ribbing.

FINISHING: See General Instructions.

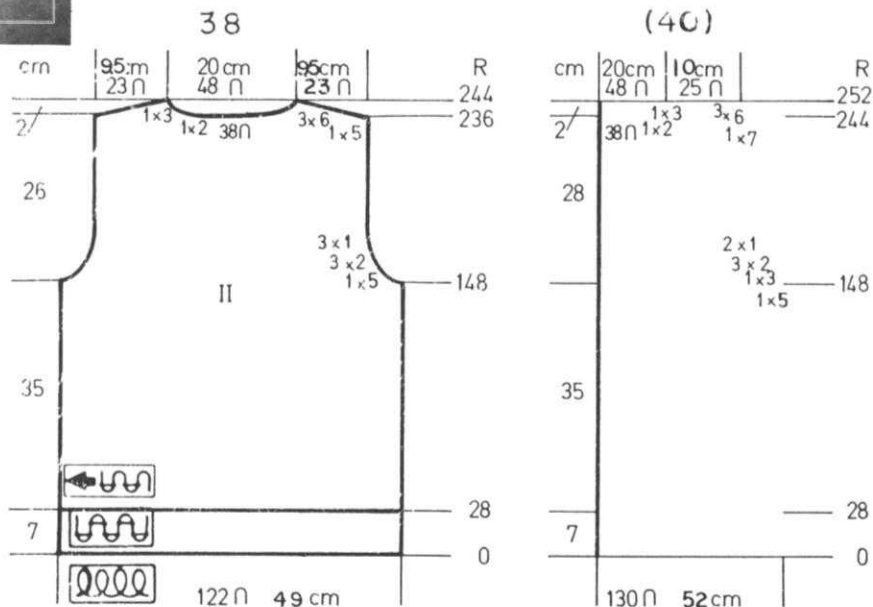

BACK: II

Cast on 122 (130) sts. with color 2 and work 28 rows Ribbing. Continue in Stockinette stitch with color stripes as follows:
 44 rows color 2
 4 rows EACH color 1, 2, 1, 2, 1, 3, 1, 3

32 rows color 3
 4 rows EACH color 1, 3, 1, 3, then continue in color 1.
 AT THE SAME TIME, after Row 148, SHAPE ARMHOLE: ON EACH SIDE bind off
 5 sts. 1x, 2 sts. 3x, 1 st. 3x. (5 sts. 1x, 3 sts. 1x, 2 sts. 3x, 1 st. 2x).

After Row 236 (244), bind off the center 38 sts., put the needles on the left into holding position and complete the right side first.

*SHAPE SHOULDER AND NECK AT THE SAME TIME.

FOR SHOULDER, bind off
 5 sts. 1x, 6 sts. 3x.
 (7 sts. 1x, 6 sts. 3x)

FOR NECK, bind off

2 sts. 1x, 3 sts. 1x.
 Bring the needles on the left into working position, knit 1 row to the left side, turn the Row Counter back to 236 (244) and complete the left half. Follow the instructions from *.

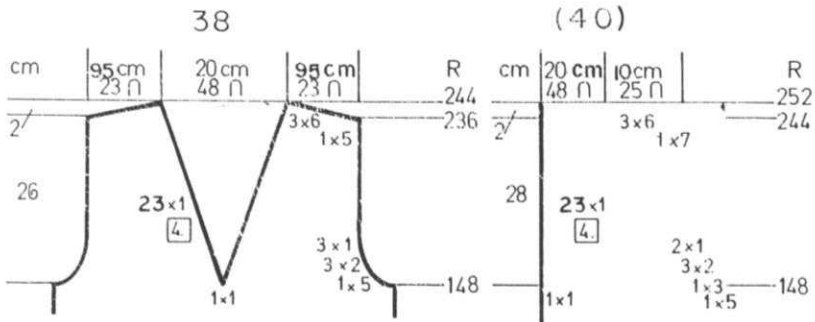

FRONT: I

Work the front the same as the back to Row 148.

Divide in the center., put the needles on the left into holding position and complete the right side first.

*ON NECK SIDE, decrease 1 st. every 4th row 23x AND AT THE SAME TIME, SHAPE ARMHOLE same as the back.

After Row 236 (244), SHAPE SHOULDER SAME AS THE BACK.

Bring the needles on the left into working position, knit 1 row to the left side, turn the Row Counter back to 148 and complete the left half. Follow the instructions from *.

ARMBANDS: Make 2.

Cast on 142 sts. with color 1 and work 10 rows K1, P1 Ribbing. Bind off or remove onto waste yarn.

NECKBAND:

Cast on 176 (190) sts. with color 1 and work K1, P1 Ribbing. ON EVERY 2nd ROW, decrease 1 st. on each side. After Row 10, bind off or remove onto contrast waste yarn.

HP 1091

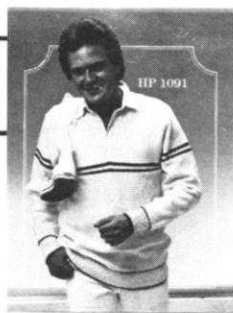

MAN'S PULLOVER

SIZES: 42 (44)
 YARN: Amore
 GRAMS:
 color 1 500 550
 color 2 50 50
 TENSION: 6 to 8
 GAUGE: 15 sts. 21 rows = 5 cm (2")

A Tuck stitch Pattern designed for the KNITKING 910 Electronic or any electronic machine. You can also punch a Card for the 881 or 360. If you use the 910 Electronic, you can space the design as shown in the picture with 10 plain sts. between designs. The KNITKING 881 or the SINGER 360 machines will be a complete 24 stitch repeat. The purl side is the right side. Bands are K1, P1 Ribbing.

FINISHING: See General Instructions.

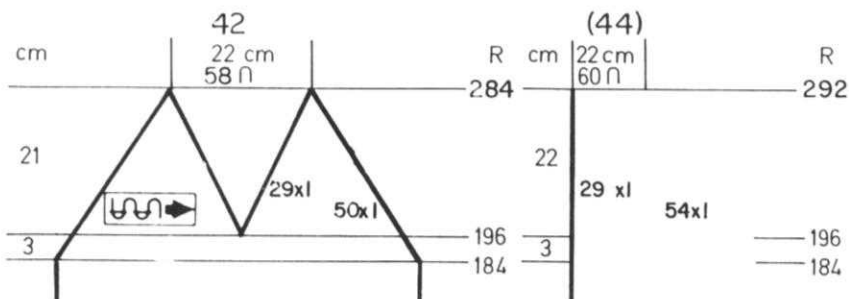
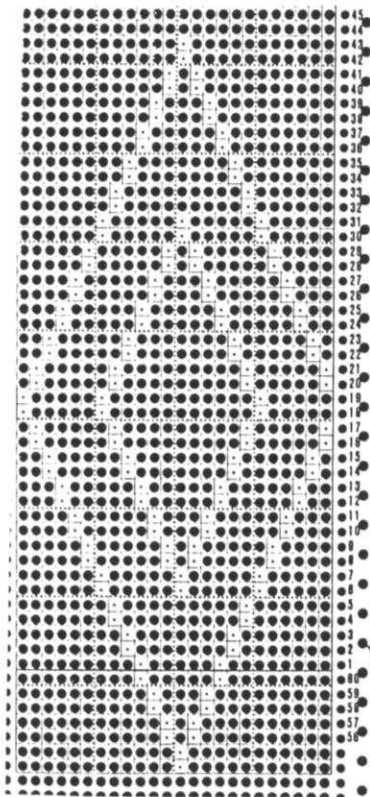

FRONT: I

Work the front the same as the back to Row 184.
 REVERSE THE KNITTING and work color stripes same as back and REVERSE again as you did for the back.

AT THE SAME TIME, SHAPE RAGLAN after Row 184.

ON EACH SIDE, bind off 1 st. 50x (54x) BUT AT THE SAME TIME after Row 196, divide in the center, put the needles on the left into holding position and work the right side first.

*ON NECK SIDE, decrease 1 st. every 2nd row 29x (29x). Bring the needles on the left into working position, knit 1 row to the left side, turn the Row Counter back to 196 and complete the left half. Follow the instructions from * and don't forget the raglan shaping.

BACK: II

Cast on 158 (166) sts. with color 2 and work K1, P1 Ribbing with color stripes of 2 rows color 2, 28 rows color 1, 2 rows color 2. Continue in Pattern with color 1. After Row 184, REVERSE THE KNITTING. Continue Stockinette st. SHAPE RAGLAN and at the same time work Stripes of 4 rows color 2, 4 rows color 1, 4 rows color 2. Reverse knitting. FOR RAGLAN, ON EACH SIDE, decrease 1 st. every 2nd row 54x (58x).

After Row 292 (300), bind off or remove onto contrast waste yarn.

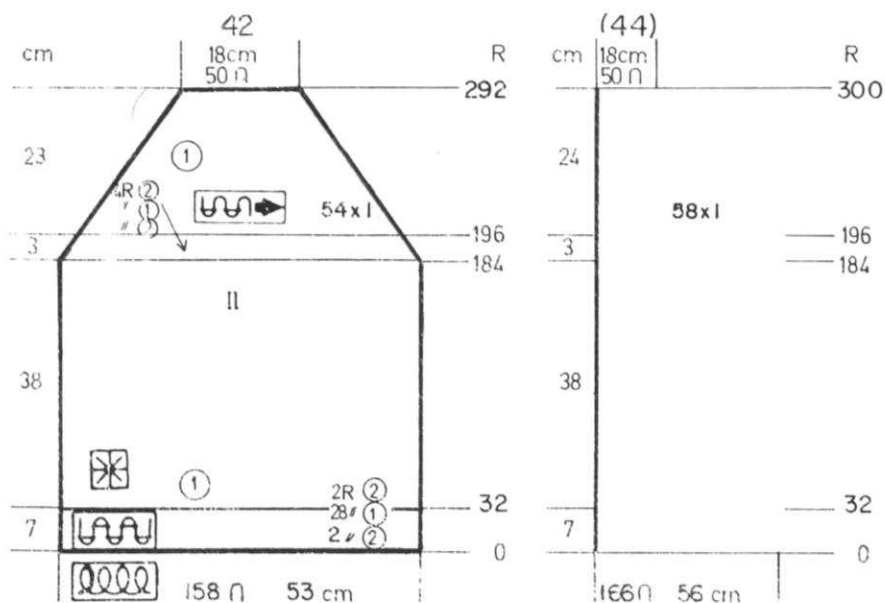

HP 1091

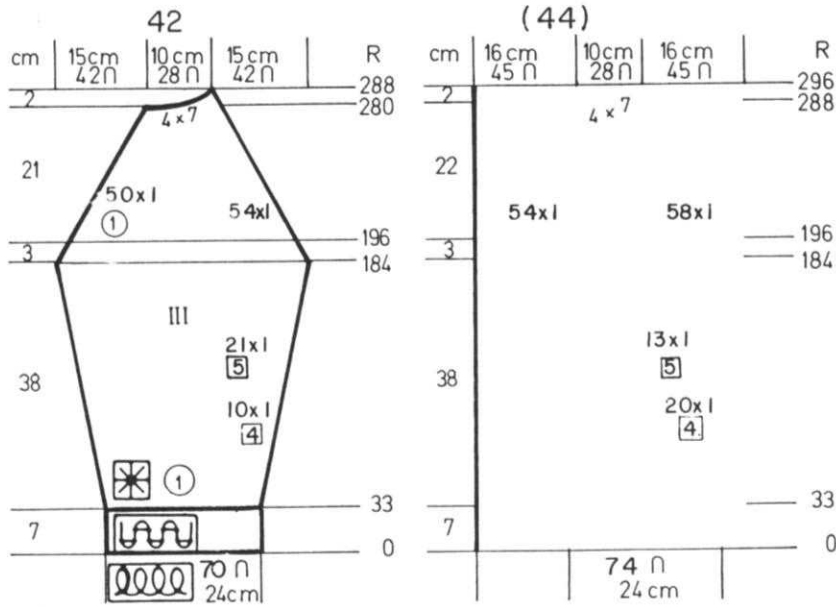

SLEEVES: III Make 1, reverse 1.

Cast on 70 (74) sts. with color 2 and work in Ribbing with color stripes same as the back and front to Row 32.
 Continue in Pattern with color 1.
 ON EACH SIDE, increase 1 st. every 4th row 10x, every 5th row 21x. (every 4th row 20x, every 5th row 13x).
 After Row 185, REVERSE THE KNITTING and continue in Stockinette stitch with color stripes same as back and front and work the Raglan Shaping (REVERSE THE KNITTING AGAIN AFTER ROW 196).
 FOR RAGLAN SHAPING, ON THE RIGHT decrease 1 st. every 2nd row 54x (58x) and on the LEFT 50x (54x).
 After Row 284 (292) work SHORT ROWS. Put into holding position opposite carriage, 7 sts. 4x.
 After Row 292 (300), bind off all sts. or remove onto contrast waste yarn.
 Work second sleeve with REVERSE SHAPINGS.

NECKBAND:

Cast on 200 sts. with color 1 and work K1, P1 Ribbing.
 ON EACH SIDE, decrease 1 st. every 2nd row 8x.
 After Row 16, bind off or remove onto contrast waste yarn.

HP 1092

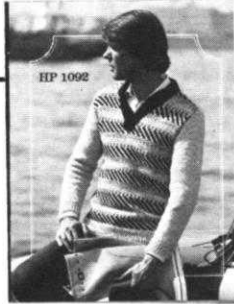

MAN'S PULLOVER

SIZES: 40 (42)
 YARN: Nomotta Alpaca
 GRAMS:
 color 1 250 300
 color 2 100 150
 color 3 50 50
 color 4 50 50

NO KIT AVAILABLE
 TENSION 8 to 9
 GAUGE: 12 1/2 sts. 15 rows = 5 cm (2")

A Fairisle Design. Punch your own Card. Bands are K1, P1 Ribbing.

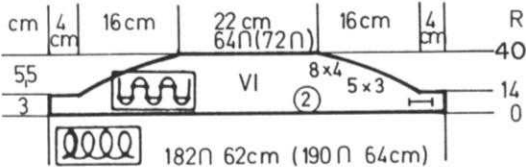
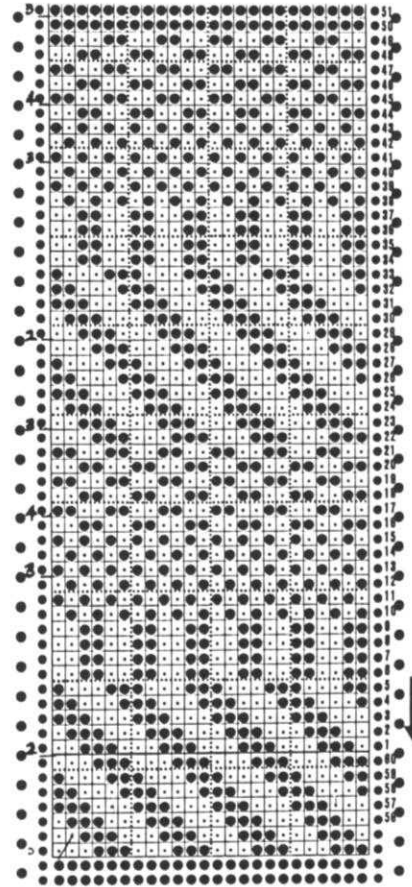

COLLAR:

Cast on 182 (190) sts. with color 2 and work K1, P1 Ribbing.
 After Row 7, make BUTTONHOLE over needles 7 to 9 counting from the right edge.
 After Row 14, ON EACH SIDE, bind off 12 sts., then on every 2nd row, bind off 3 sts. 5x, 4 sts. 8x.
 After row 40, bind off the remaining sts.

HP 1092

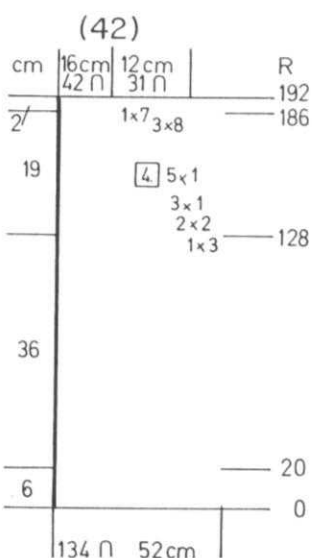
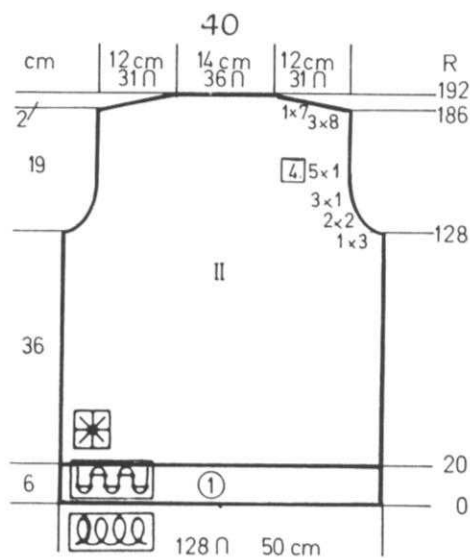

BACK: II

USE COLOR CHANGER
 Cast on 128 (134) sts. with color 1 and work 20 rows Ribbing. Continue in Pattern with changes in color as follows.
 *12 rows colors 1 & 2
 4 rows colors 1 & 3
 6 rows colors 1 & 4
 6 rows colors 1 & 3
 REPEAT FROM * for pattern.
 After Row 128, SHAPE ARMHOLE: ON EACH SIDE, bind off 3 sts. 1x, 2 sts. 2x, 1 st. 3x, 1 st. every 4th row 5x. (3 sts. 1x, 2 sts. 2x, 1 st. 3x, 1 st. every 4th row 5x).
 After Row 186, SHAPE SHOULDER. ON EACH SIDE, bind off 8 sts. 3x, 7 sts. 1x for both sizes.
 After Row 192, bind off the remaining sts.

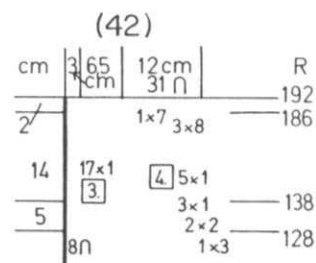
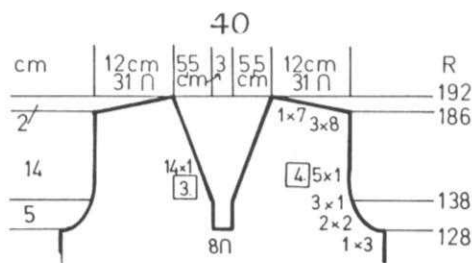

FRONT: I

Work the front the same as the back to Row 128. Bind off the center 8 sts., put the needles on the left into holding position and complete the right side first.
 *SHAPE ARMHOLE SAME AS THE BACK BUT AT THE SAME TIME, after Row 138, ON NECK SIDE, decrease 1 st. every 3rd row 14x (17x).
 After Row 186, SHAPE SHOULDER same as the back.
 Bring the needles on the left into working position, knit 1 row in Pattern to the left side, turn the Row Counter back to 128 and complete the left half. Follow the instructions from *.

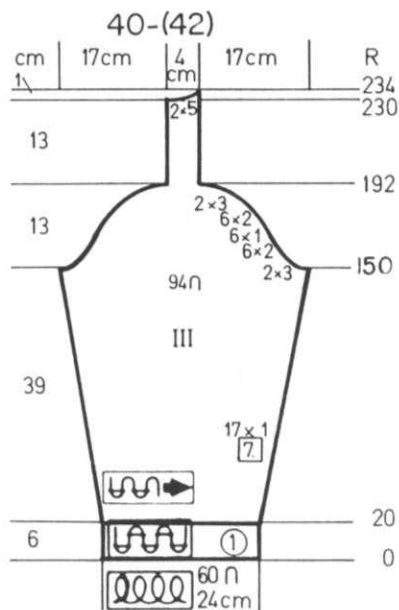

SLEEVES: III Make 1, reverse 1.

Cast on 60 sts. with color 1 and work 20 rows Ribbing. Continue in Stockinette stitch with color 1. ON EACH SIDE, increase 1 st. every 7th row 17x. After Row 150, SHAPE CAP: ON EACH SIDE, bind off 3 sts. 2x, 2 sts. 6x, 1 st. 6x, 2 sts. 6x, 3 sts. 2x. After Row 192, knit even to Row 230. WORK SHORT ROWS. ON OPPOSITE SIDE OF CARRIAGE, put into holding position, 5 sts. 2x. After Row 234, bring all the needles into work and bind off. Work the second sleeve with reverse shaping for the SHORT ROWS.

DK 1093



WOMAN'S JACKET

SIZES: Medium Large
 YARN: Nomotta Super Show
 GRAMS:
 color 1 250 300
 color 2 100 100
 color 3 100 100
 color 4 50 50
 color 5 50 50
 color 6 50 50

NO KIT AVAILABLE

TENSION: 10

GAUGE: 10 sts. 11 1/2 rows = 5 cm (2")

A Norwegian Design with bands
 in K1, P1 Ribbing. Punch Card.

FINISHING: See General Instructions.

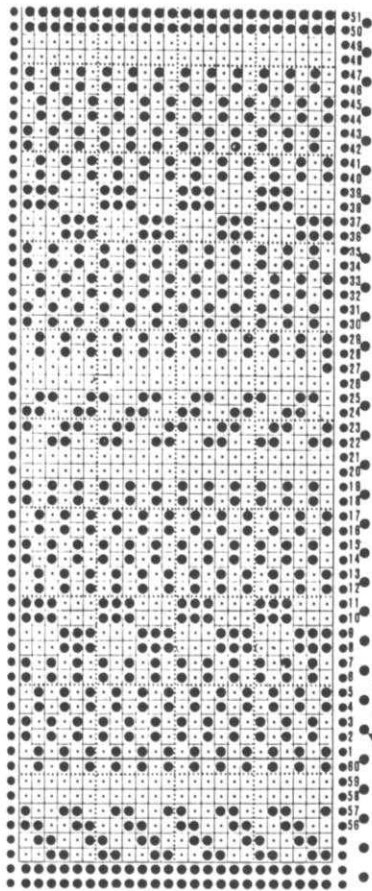

BACK: II

Cast on 106 (110) sts. with color 1 and work 14 rows K1, P1 Ribbing. Transfer the Ribber sts. to main machine and continue in Norwegian Design with color changes as shown. ON EACH SIDE, decrease 1 st. every 11th row 4x. Continue in Pattern to Row 104. SHAPE RAGLAN: ON EACH SIDE, *decrease 2 sts. 1x, 1 st. 4x and REPEAT from * 4x (5x) more. then decrease 1 st. 7x (3x). After Row 172 (174), bind off the remaining sts.

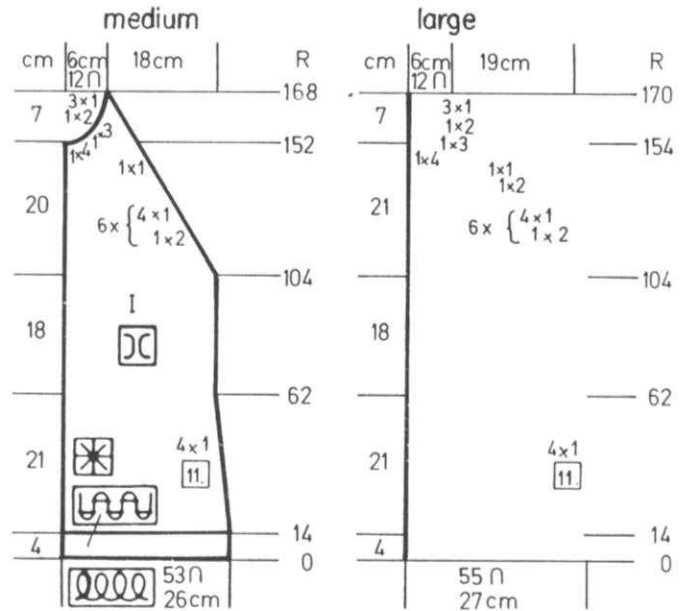

FRONT: I Make 1, reverse 1.

Cast on 53 (55 sts. with color 1 and work 14 rows K1, P1 Ribbing. Continue in Pattern same as back.

ON SIDE EDGE, decrease 1 st. every 11th row 4x.

After Row 104, SHAPE RAGLAN:

*Decrease 2 st. 1x, 1 st. 4x and REPEAT from * 5x MORE, then decrease 1 st. 1x (2 sts. 1x, 1 st. 1x).

After Row 151 (153) ON NECK SIDE, bind off

4 sts. 1x, 3 sts. 1x, 2 sts. 1x, 1 st. 3x.

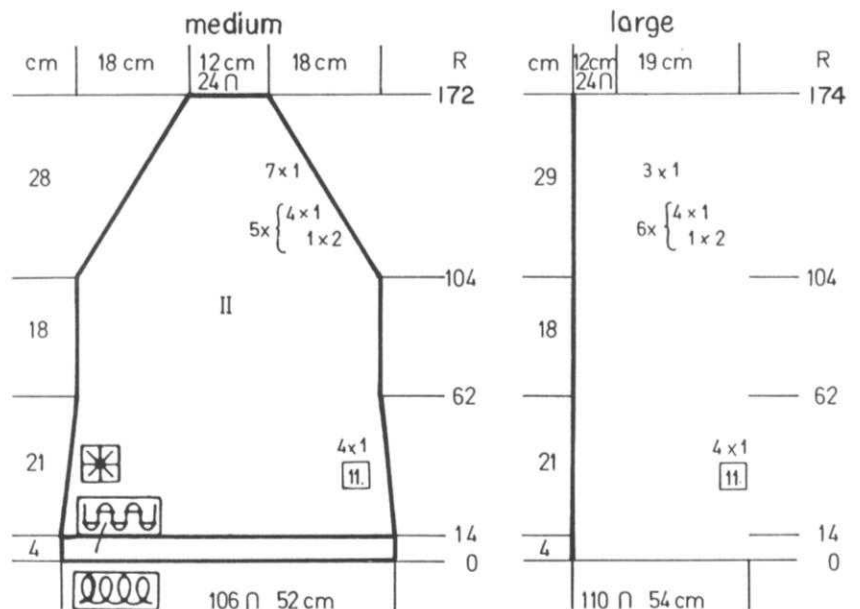

DK 1093

SLEEVES: III

Cast on 50 sts. with color 1 and work 14 rows K1, P1 Ribbing. Continue in Pattern. ON EACH SIDE, increase 1 st. every 6th row 16x. After Row 108, SHAPE RAGLAN: Please follow the DIFFERENT bind offs ON EACH SIDE as shown on the Chart for your size. After Row 172 (174), work SHORT ROWS. ON OPPOSITE SIDE OF CARRIAGE, put into holding position 6 sts. 2x. After Row 176 (178) bring all the needles into working position and bind off.

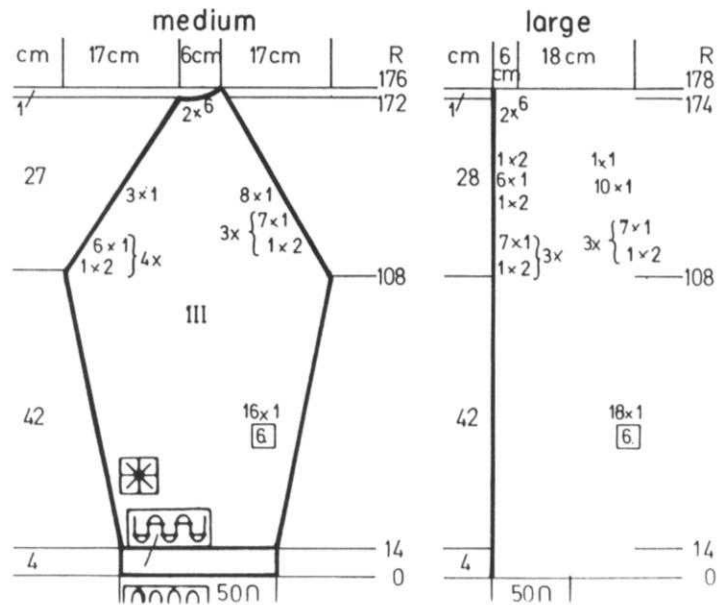

FRONT BANDS: Make 2.

BELT:

Cast on 13 sts. with color 1 and work K1, P1 Ribbing for approximately 110 cm (43 to 44") long.

NECKBAND:

Cast on 97 sts. with color 1 and work 30 rows K1, P1 Ribbing. Bind off.

Cast on 127 (129) sts. with color 1 and work 14 rows K1, P1 Ribbing. Bind off. Make 2nd band the same. When sewing the right side band in place, Space openings for buttonholes. See Picture. Finish buttonholes and sew on buttons.

DK 1094

WOMAN'S VEST

SIZES: 6/8 (10/12)
YARN: Nomotta Top Tweed
GRAMS: 300 350
TENSION: 9
GAUGE: 12 1/2 sts. 15 rows = 5 cm (2")

A Lace Pattern. Punch your own Card. Bands are K1, P1 Ribbing.

FINISHING: See General Instructions.

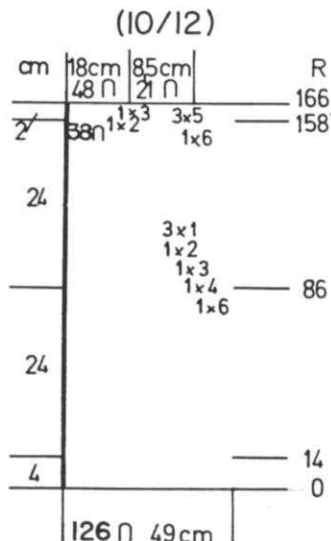
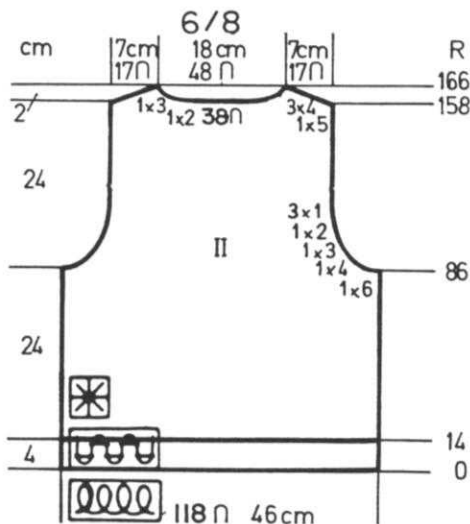

BACK: II

Cast on 118 (126) sts. and work 14 rows K1, P1 Ribbing. Continue in Lace Pattern. Knit to Row 86. SHAPE ARMHOLE: ON EACH SIDE, bind off 6 sts. 1x, 4 sts. 1x, 3 sts. 1x, 2 sts. 1x, 1 st. 3x. Knit to Row 158. Bind off the center 38 sts., put the needles on the left into holding position and complete the right side first. *SHAPE SHOULDER AND NECK AT THE SAME TIME. FOR SHOULDER, bind off 5 sts. 1x, 4 sts. 3x. (6 sts. 1x, 5 sts. 3x). FOR NECK, bind off 2 sts. 1x, 3 sts. 1x. Bring the needles on the left into working position, knit 1 row to the left side, turn the Row Counter back to 158 (watch Pattern) and complete the left half. Follow the instructions from *.

DK 1094

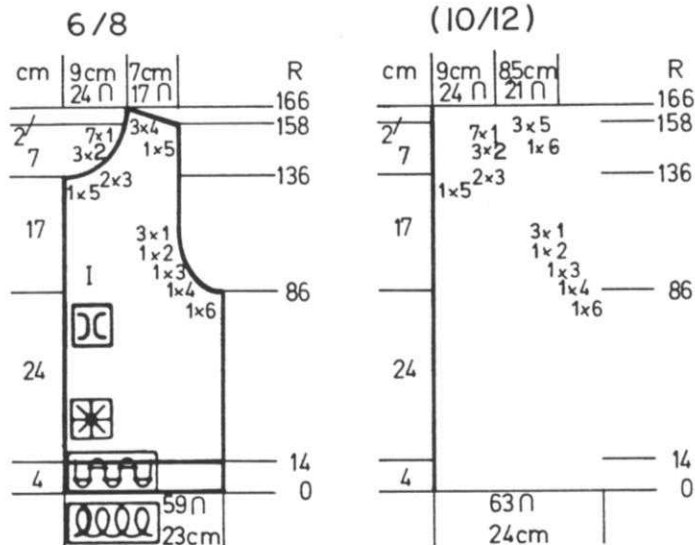

FRONT: I Make 1, reverse 1.

Cast on 59 (63) sts. and work 14 rows K1, P1 Ribbing. Continue in Lace Pattern. After Row 86, SHAPE ARMHOLE: Bind off 6 sts. 1x, 4 sts. 1x, 3 sts. 1x, 2 sts. 1x, 1 st. 3x for both sizes. After Row 135, SHAPE NECK: Bind off 5 sts. 1x, 3 sts. 2x, 2 sts. 3x, 1 st. 7x for both sizes. After Row 158, SHAPE SHOULDER same as the back.

ARMBANDS:

Cast on 142 sts. and work 14 rows K1, P1 Ribbing. Bind off or remove onto contrast waste yarn.

FRONT BANDS: BUTTON & BUTTONHOLE BANDS.

Cast on 110 sts. and work K1, P1 Ribbing. After Row 8, MAKE BUTTONHOLES over needles 6 to 9, 28 to 31, 50 to 53, 72 to 75, 94 to 97. After Row 14, bind off or remove on contrast waste yarn. Make 2nd band but OMIT the buttonholes.

NECKBAND:

Cast on 130 sts. and work K1, P1 Ribbing. After Row 8, MAKE BUTTONHOLE over needles 6 to 9 counting from 1 edge. After Row 14, bind off or remove onto contrast waste yarn.

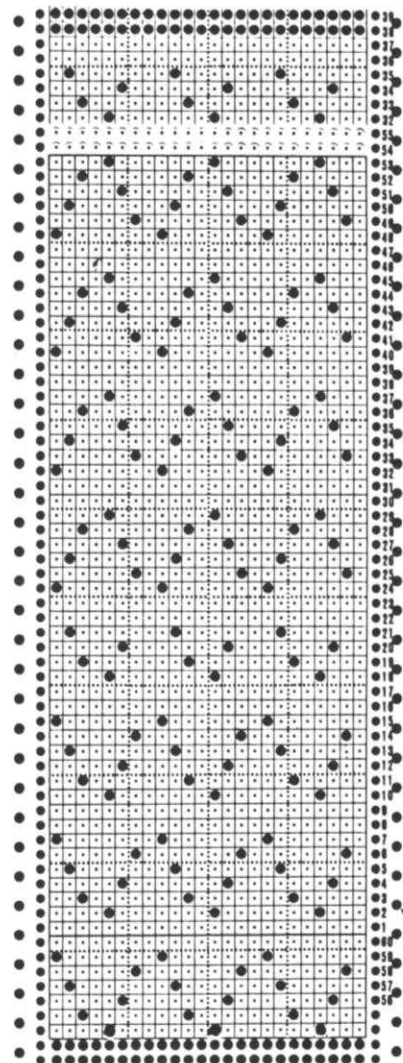

knitking announces their 1982

SEMINAR

On the premises at 1128 Crenshaw Blvd., Los Angeles, Calif. 90019. Commencing Monday, October 11th and running through Saturday, the 16th. During the five weekdays the Seminar will operate from 10 a.m. until 4 p.m., and on Saturday from 10 a.m. until 1 p.m.

Admission will be FREE - Coffee and Doughnuts will be available at 9:30 a.m. daily. Plan to be with us and to meet the knitting experts at KNITKING. Classes and Lectures on all phases of machine knitting - Measuring - Charting, etc., will continue throughout every day.



KNITTING NEWS

PRACTICAL KNITTING HINTS

PROBLEM YARNS

You can run into problems when knitting with some yarns, such as FINE MOHAIR, LOOPY YARN or KNITTING WORSTED over every 2nd needle, or hard twisted RAYONS etc... However, before you give up, try the following (for Stockinette stitch only).

Turn the control on your knitting carriage to the KC position and leave it there. This brings the needles into the selecting position and helps to keep the yarn from catching on the gate pegs of the machine. You must watch and pull the knitting down and away from the front of the gate pegs occasionally. Any hard finish yarn should be waxed either by winding the yarn into a ball and at the same time allowing the yarn to pass over a block of paraffin as you wind. (When you do this and you knit from a center pull ball, you should wind the yarn a second time without wax as the first winding could be too tight). You can also use our Super Spray Wax to spray the outside of a cone or ball of yarn periodically as you are knitting. You will be able to feel the pull on the yarn when it becomes necessary to spray again. If, after trying to knit with a specific yarn and nothing works, you should pick out a Weaving Pattern and use the problem yarn for weaving.

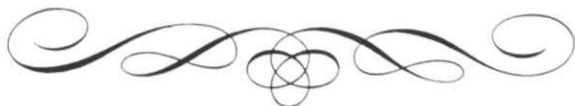

KITS AVAILABLE FOR THIS ISSUE OF KNITTING MAGAZINE

Be sure to check the colors available listed at the end of this Newsletter and make certain to give alternate colors.

DK 1075 - Yarn: Venetia and Amore
SIZES: 6 (8/10)
Price: \$39.56 \$49.56
Shipping costs 2.50 2.50

HP 1076 - Yarn: Amore
SIZES: 40 (42) [44]
Price: \$40.63 \$40.63 \$45.41
Shipping costs 1.85 1.85 1.85

DK 1077 - Yarn: Sport weight yarn.
NO KIT AVAILABLE.

DK 1078 - Yarn: Fine yarn, Gold Lurex, Fine Chenille.
NO KIT AVAILABLE.

DK 1079 - Yarn: Fortissima
SIZES: 4/6 (8/10)
Price: \$30.96 \$33.54
Shipping costs 1.85 1.85

KK 1080 - Yarn: Sport weight or any suitable yarn that knits at the same stitch gauge. NO KIT.

DK 1081 - Yarn: Venetia
SIZES & Price: 8 through 12 \$45.00
14 through 18 \$50.00

Shipping costs \$2.50 each Kit.
SEE EDITORIAL regarding free Knitleader or Knit Contour charts. \$5.00 per set if purchased separately.

DK 1082 - Yarn: Mohair and Boucle or any yarn that knits at the same stitch gauge. NO KIT.

DK 1083 - Yarn: Soft Knitting Worsted weight. Knitleader or Knit Contour Charts \$5.00 each set. Specify size needed (8 to 18)60¢ Shipping. NO KIT.

DK 1084 - Yarn: Beatrice Silver
SIZES: 6 (8/10)
Price: \$20.34 \$23.73
Shipping costs 1.85 1.85

DK 1085 - Yarn: Fortissima
SIZES: 10 (12) [14/16]
Price: \$18.06 \$20.64 \$20.64
Shipping costs 1.85 1.85 1.85

DK 1086 - Yarn: Venetia and Amore
SIZE: 10/12
Price: \$51.95
Shipping costs 2.50

DK 1087 - Yarn: Venetia and fine yarn for plating. Knitleader or Knit Contour Charts free with the purchase of 3 lbs. Venetia for Sizes 8 to 12 - Price: \$60.00 - 3 1/2 lbs. for Sizes 14 to 18 - Price: \$70.00. Use a 2/22 or 2/24 yarn for plating the Jacket or make the Suit in one color of Venetia. Shipping costs \$2.50 each size Kit. Plating yarn not included.

Knitleader or Knit Contour charts \$5.00 each per set if purchased separately. 60¢ Shipping costs.

DK 1088 - Yarn: Sport Weight yarn or any suitable yarn that knits at the same stitch gauge. NO KIT.

DK 1089 - Yarn: Amore
SIZE: 10/12
Price: \$23.90
Shipping costs 1.85

HP 1090 - Yarn: Nomotta Viola or any yarn that knits at the same stitch gauge. NO KIT.

HP 1091 - Yarn: Amore
SIZES: 42 (44)
Price: \$26.29 \$28.68
Shipping costs 1.85 1.85

HP 1092 - Yarn: Nomotta Alpaca or any yarn that knits at the same stitch gauge. NO KIT.

DK 1093 - Yarn: Nomotta Super Show or any yarn that knits at the same stitch gauge. NO KIT.

DK 1094 - Yarn: Nomotta Top Tweed or any yarn that knits at the same stitch gauge. NO KIT.





DK 1089



DK 1083



DK 1079

DK 1093



HP 1092

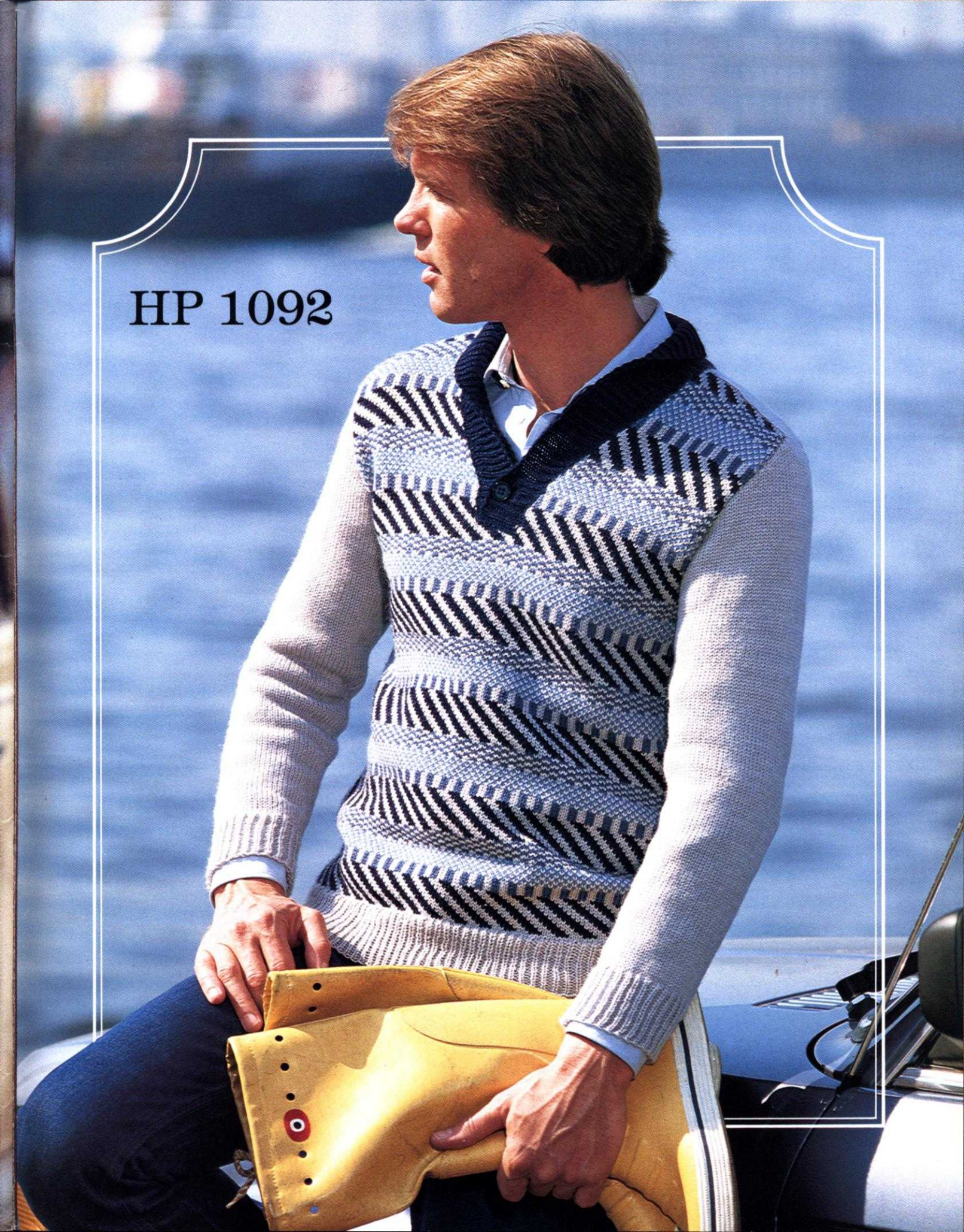

HP 1091

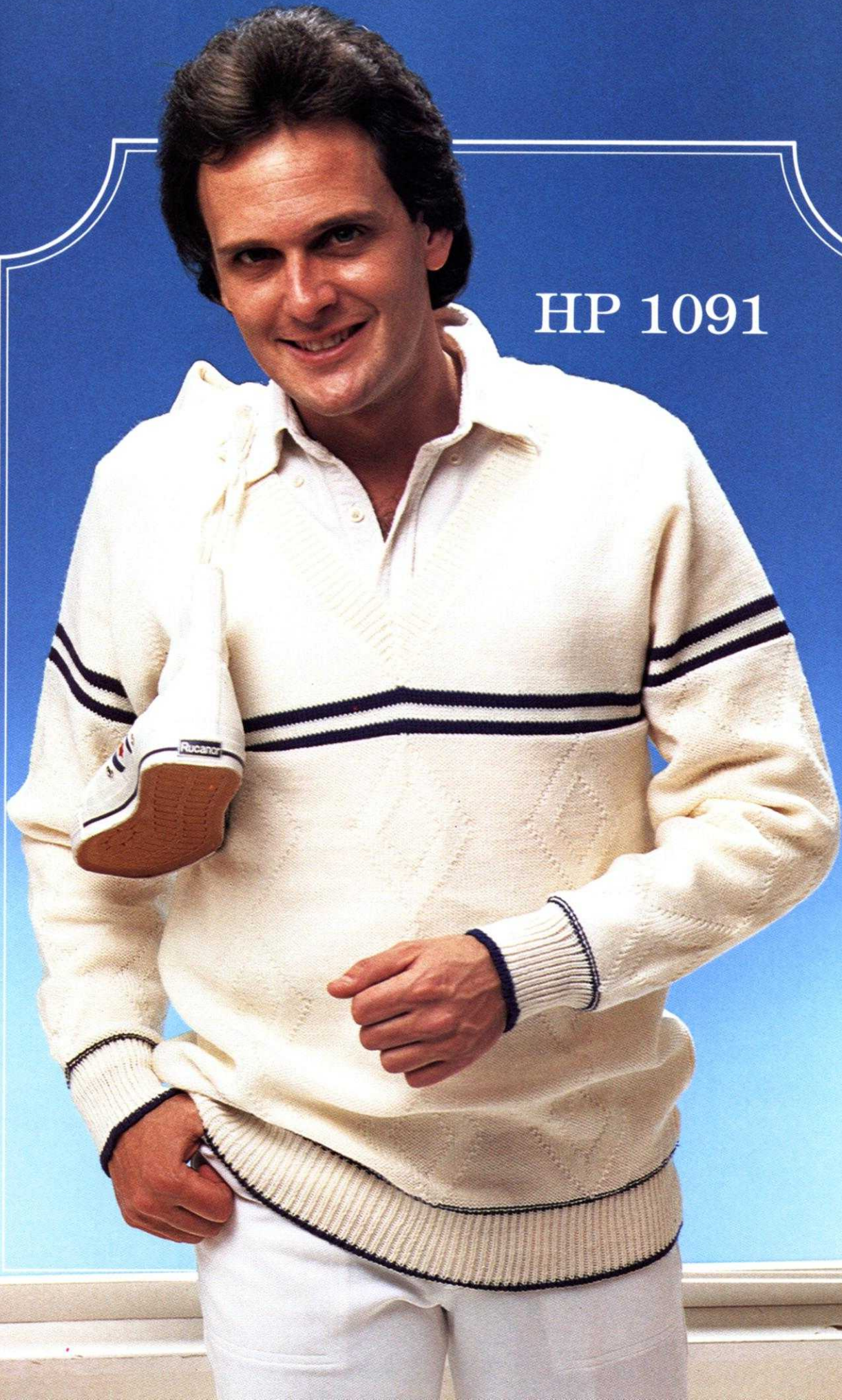

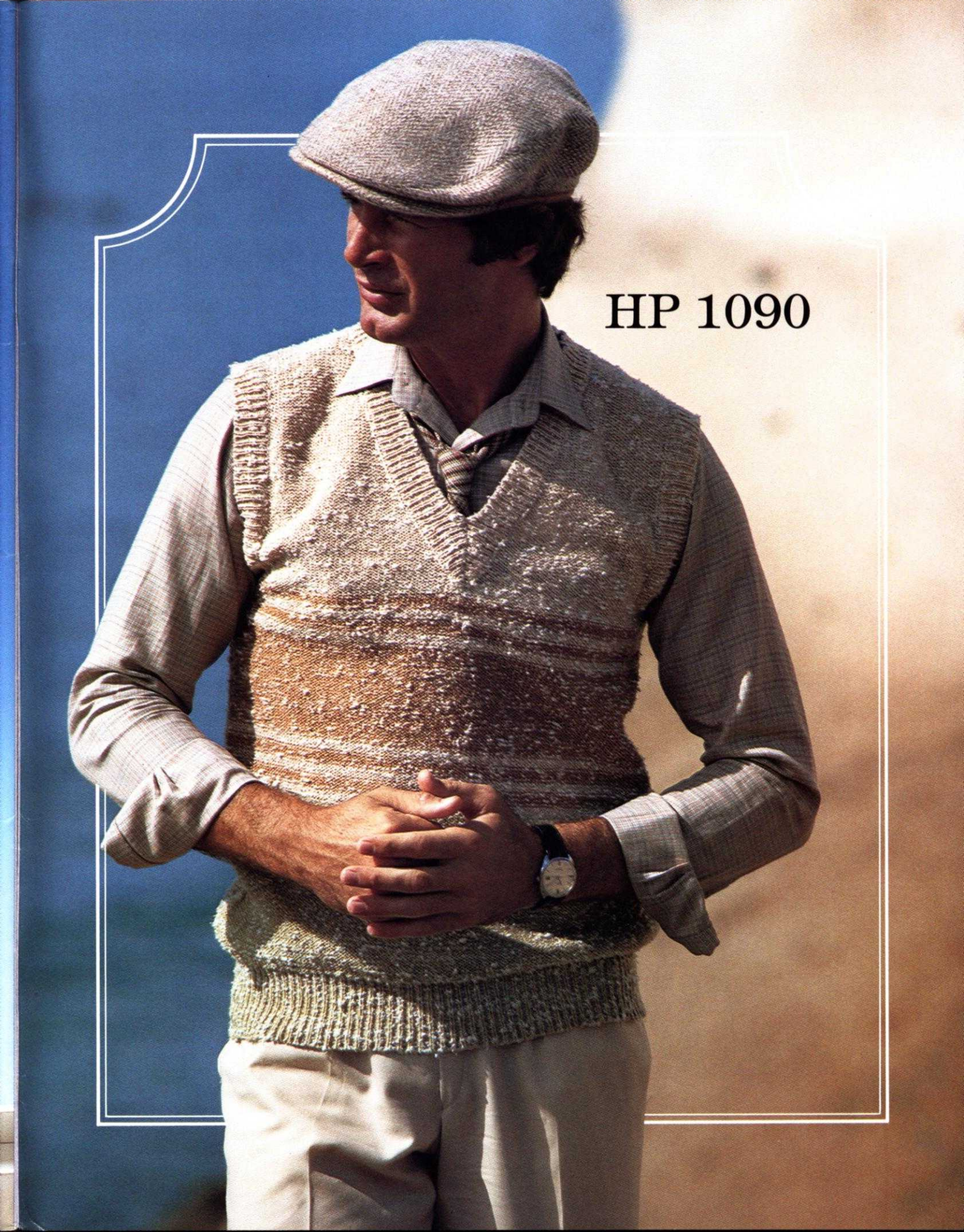
A man is shown from the waist up, wearing a light-colored tweed flat cap, a light-colored long-sleeved shirt with a striped tie, and a textured, light-colored sweater vest with horizontal stripes. He is looking to his left with his hands clasped in front of him. He is also wearing a watch on his left wrist. The background is a gradient from blue on the left to light brown on the right. A white decorative frame surrounds the man.

HP 1090

KK 1080



HP 1076

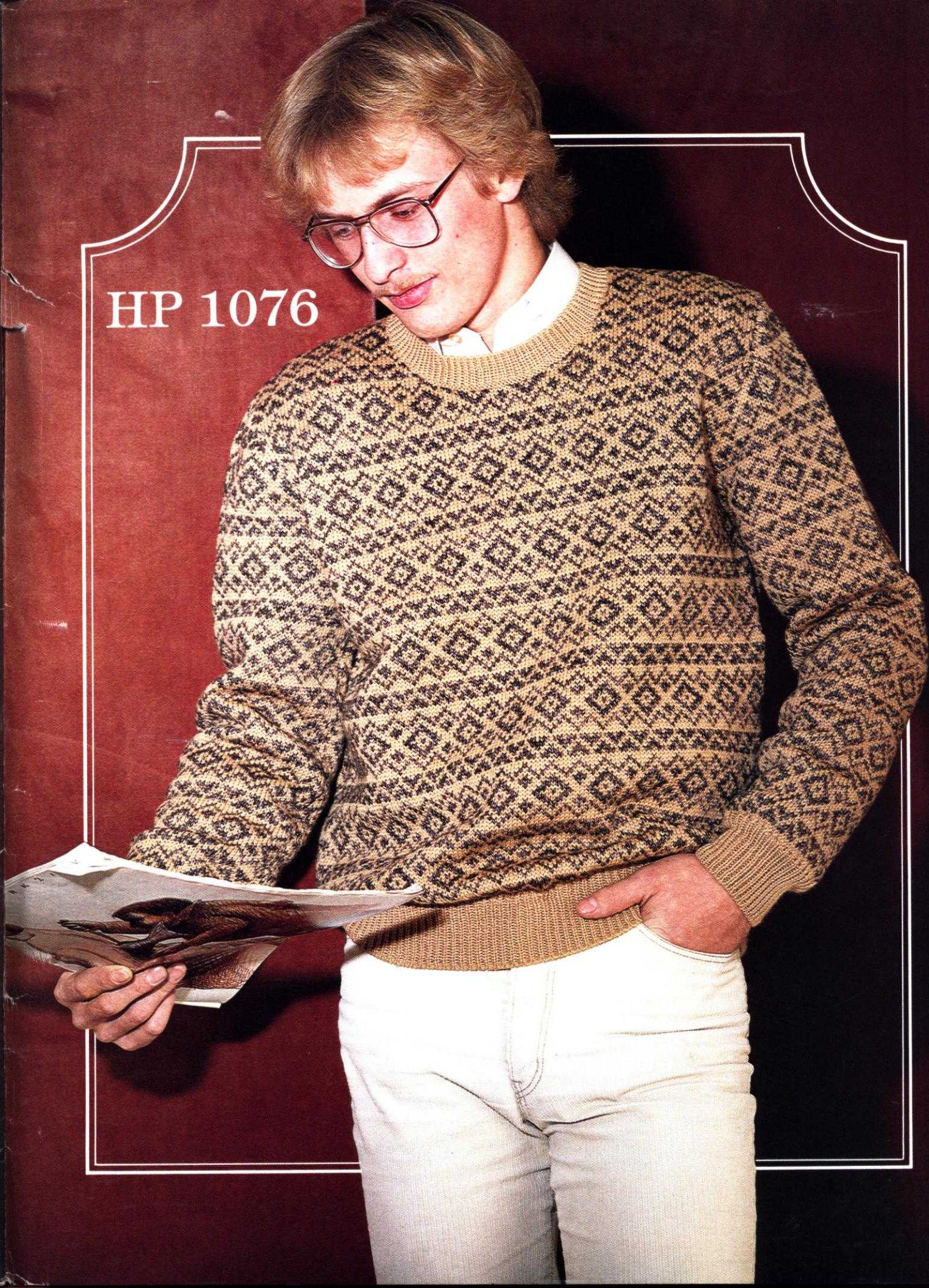

DK 1094

