

A woman with brown hair pulled back, wearing a green, white, and brown striped sweater and a matching green ribbed skirt, stands in a garden with white flowers. She is smiling and has her hands on her hips. The background is a lush green garden with a tree in bloom.

knitking

magazine

Flattering Ribbed Skirts
Standard and Bulky

Combination Knitting
Use Standard and Bulky Together

Family Affair
Fabulous Raglans For All

Terrific Tuck Knitting
Trims, Sweaters, Multi-Color and More

Volume 26, Issue 1

The Designer Touch

978

You will catch every eye when you wear this striking Pullover. It's knitted in a Tuck stitch pattern on a standard Punch Card or Electronic machine. The back slit is accented with buttons for that special designer look. The sleeve cuffs are knitted using short rows for a perfect fit. The yarn is Primo.





Fashionable Fun

▶ 979

Be comfortable and fashionable at the same time. This oversized top is just what the young girls love but looks equally great on Mom too. The front and back are each made in two sections that include the sleeves. It's a large Fair Isle Design with a border pattern used for neck and sleeve bands. Wear it over a striped fairisle Mini Skirt that picks up the border pattern at hemline. Knitted on the standard Punch Card or Electronic machine with Venetia and Woolana.

TABLE OF CONTENTS

KNITKING MAGAZINE - VOLUME 26 NO. 1

0000	GENERAL INSTRUCTIONS	11
977	WOMENS TWO-PIECE with RIBBED SKIRT	13
978	TUCK SWEATER with SPECIAL SHORT ROW CUFF	14
979	TWO-PIECE ENSEMBLE with OVERSIZED TOP & MINI SKIRT	16
980	THREE-PIECE ENSEMBLE	18
981	BULKY INTARSIA WEAVING PULLOVER	21
982	BULKY SHORT CARDIGAN JACKET	22
983	MENS FAIRISLE PULLOVER	23
984	BUTTON-FRONT PULLOVER	24
0000	TECHNICAL TIPS	25
985	WOMENS TWO-PIECE DRESS with SURPLICE PULLOVER	26
986	WOMENS TUCK AND RIBBED STRIPED DRESS	28
987	MENS STRIPED TUCK PULLOVER	29
988	TWO-PIECE DRESS with FAIRISLE PULLOVER	32
989	BULKY JACKET with GARTER BAR TURNS	34
990	GIRLS RAGLAN PULLOVER	35
991	BOYS RAGLAN CARDIGAN	37
0000	KNITKING NEWS	38
992	MENS RAGLAN CARDIGAN	39
993	MENS G-CARRIAGE V-NECK PULLOVER	40
994	WOMENS FAIRISLE PULLOVER	43
995	CABLE FRONT PULLOVER with LACE SLEEVES	44
996	SHORT SLEEVE TUCK PULLOVER	45

EDITORIAL

Dear Readers . . .

I think most knitters will agree that one of the most fun things about machine knitting is the special thrill you get when you share your passion with friends. I know that I get personal satisfaction by saying, "I made this," or when I adhere my own special "made for you by . . ." label to a knitted gift. People never cease to be amazed, delighted and fascinated by the notion of creating a hand knit garment or craft in record time. Their interest provides the perfect opportunity to expound on the joys of machine knitting. It's like sharing a delicious recipe, or passing on a great word-of-mouth movie review—you are sharing your knowledge about a hobby that could be just the thing your friends would love! They can have a wonderful creative outlet for themselves which results in a closet full of beautiful clothes—not to mention knitted gifts extraordinaire!

You may ask yourself, "How would I go about introducing my friends to the fun of machine knitting?" All you need to do is "spread the word." Think of yourself as a goodwill ambassador to the world of machine knitting! Showing friends your beautiful garments and letting them know how much fun you had making them is a great way to see how interested they may be in machine knitting! Then invite them over to your home and show them first hand how easy and fast it is. Before you know it, your friends will be enjoying machine knitting as much as you do, and thanking you over and over again for introducing them to such a terrific, satisfying hobby.

After you have friends involved, you will especially enjoy getting together on a regular basis (say once a month) to share your ideas and projects in a knitting "club." You and your friends might even treat yourself to a trip to a machine knitting seminar. Attending a knitting seminar is a staggering experience. You get caught up in the enthusiasm of seeing the unlimited possibilities available to you. Terrific new ideas abound and you get to meet people from all over who are just downright fun to be with!

If you've never attended a knitting seminar, join us at KnitKING headquarters September 22-26, 1992 for five full days (free of charge) of demonstrations and classes taught by industry experts; fashion shows and more. It's a fun-filled experience that will leave you chomping at the bit to get home and knit, knit, knit!

We hope to see you — and your friends—soon!

Suzanne Str

Superlative

977

A two piece ensemble that will be a favorite to wear everywhere. It's easy to knit on any Bulky Machine with Ribbing Attachment. The top is Stockinette stitch with

stripes of soft color. Repeat the stripes on the sleeves. Knit the Skirt in a 2 x 1 Rib to match the ribbed bands on the Pullover. The yarns are Alpine and Woolana.



Publisher: KNITKING CORPORATION, 1128 Crenshaw Blvd.
Los Angeles, CA 90019. Telephone: (213) 938-2077. Published quarterly.
Subscriptions: USA-\$24.00 annually; single copies \$7.95. \$29.00-all other countries. The entire contents of KNITKING MAGAZINE are copyrighted and must not be reproduced in any shape or form without the express permission, in writing, of the publisher.
® COPYRIGHT 1992 KNITKING CORPORATION

Photography by : NILS VIDSTRAND STUDIOS

Contemporary Design

980

A beautiful three piece ensemble is the perfect choice for any busy day. The Jacket is Stockinette stitch with contrasting stripes on body and sleeves. The top is a multi-color tuck design. The ribbed Skirt is made with a special needle set-up on the main bed and ribber to form an interesting pattern. Knit it with Primo on a standard Punch Card or Electronic machine.

981

Intarsia Weaving

Believe it or not, Intarsia Weaving is easy and fun to do and the results are spectacular.

A gay and colorful Pullover the young set will love and you will want one too. Rib the bands. Knit it on the Punch Card Bulky or Electronic Bulky with Ribber using our Alpine and Caprinae.

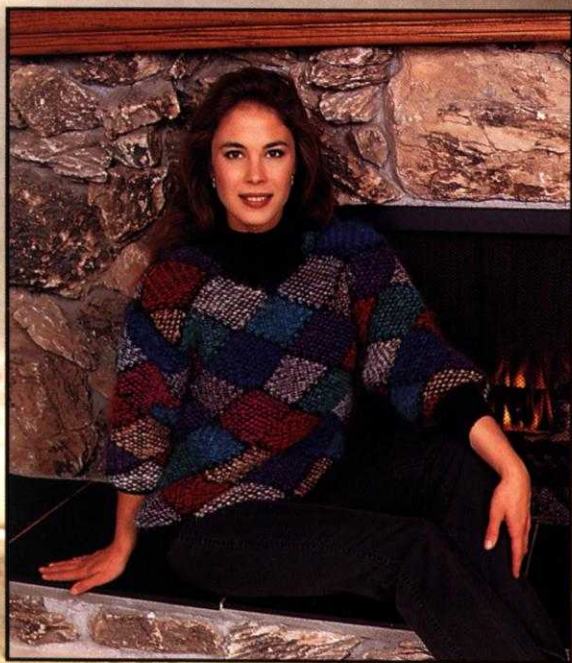

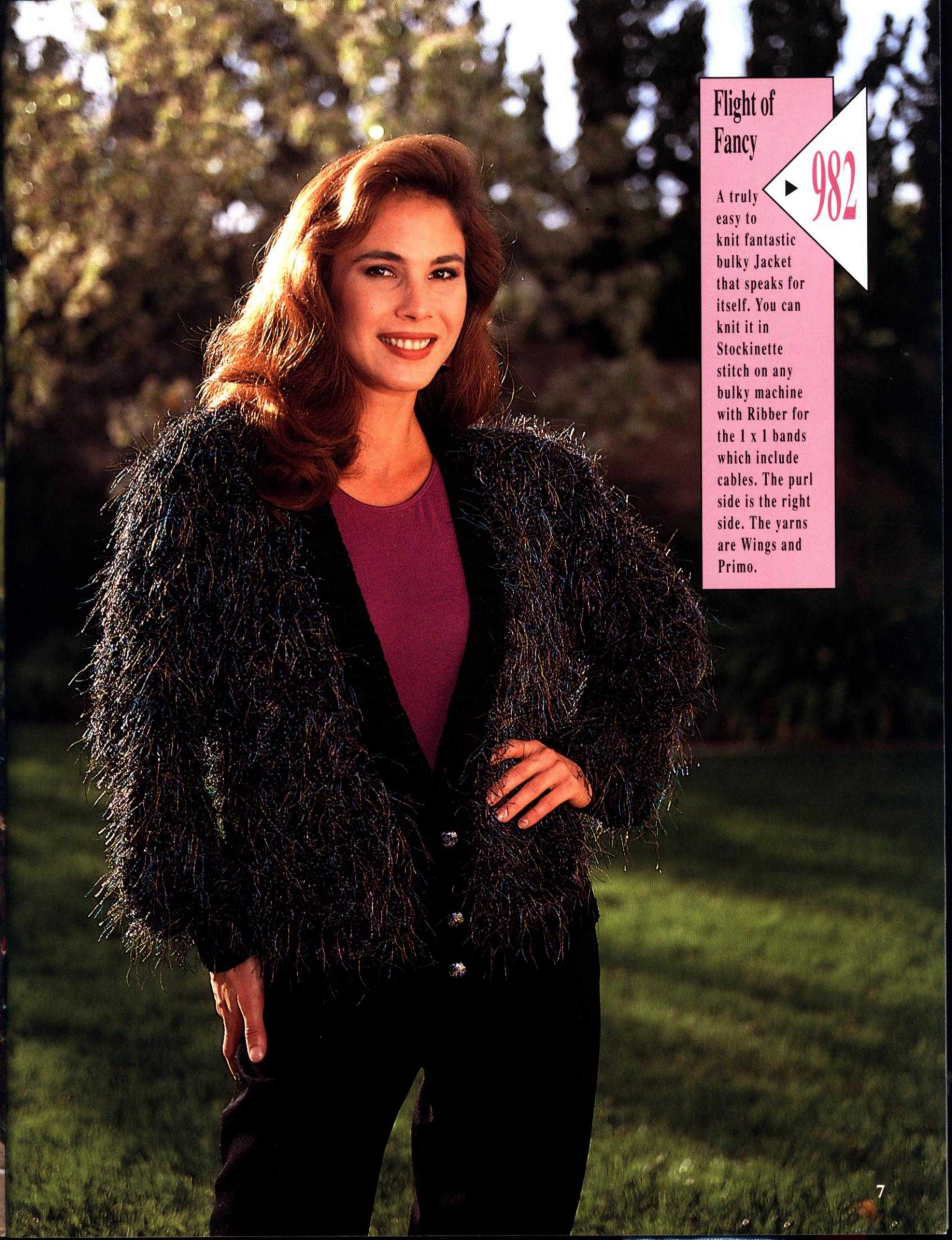

Flight of Fancy

▶ 982

A truly easy to knit fantastic bulky Jacket that speaks for itself. You can knit it in Stockinette stitch on any bulky machine with Ribber for the 1 x 1 bands which include cables. The purl side is the right side. The yarns are Wings and Primo.

Essentially
His

983

Uplift his spirits and knit your man this colorful Fair Isle Pullover in terrific colors. It's a Fair Isle Design that is knitted on a standard Punch Card or Electronic machine with 1 x 1 ribbing for the bands. The yarns are Softon and Panache.

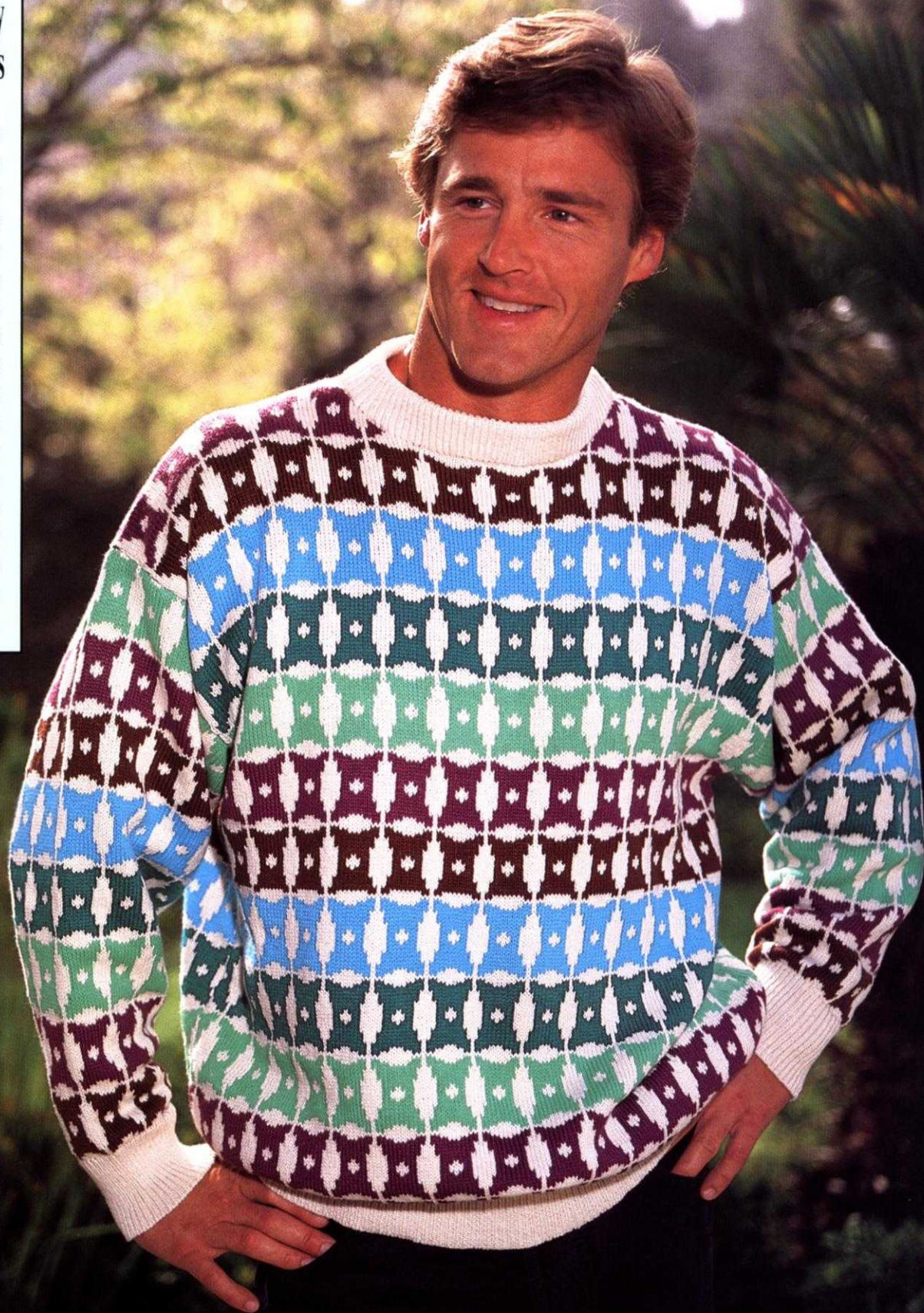

Serenity

▶ 984

Take a break and relax in a lovely button front basic Stockinette stitch Pullover. The flattering notched Collar is in full needle ribbing. The bands are 1 x 1 Rib. Knit it with Venetia on a standard Punch Card or Electronic machine.

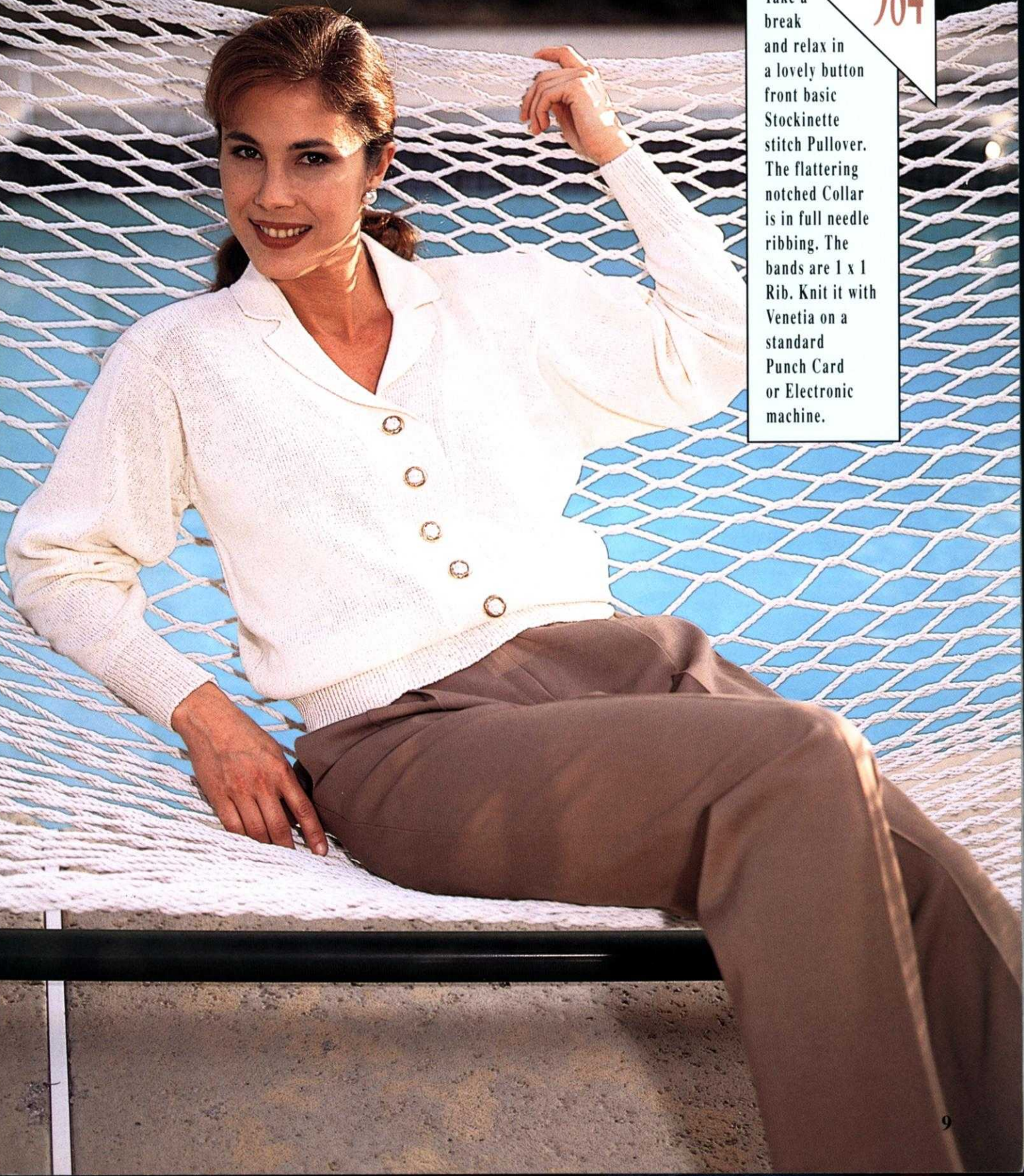

Center Stage

985

All eyes are on you when you wear this beautiful two-piece Dress. The surplice Top is made on a Punch Card or Electronic Bulky in Stockinette stitch with a tuck stitch to trim the neckline. The Skirt is knitted sideways on a standard gauge machine using short rows with eyelets to divide the sections. The yarns are Venetia, Angora and Glace.



GENERAL INSTRUCTIONS

THE SAMPLE SWATCH

It is imperative that you knit a sample swatch for every garment. Although you may be using the identical yarn and machine model as the pattern suggests, many variables such as dye lot difference, speed of knitting and just machine to machine differences can all cause a variance in the gauge achieved. Knit Magazine publishes the tension and gauge for each garment shown. We strongly urge you to knit a swatch representing three tensions - the recommended tension, and .1 or .2 higher and lower. These different tensions can be knitted in one piece with waste yarn separating the sections. This will eliminate unnecessary rethreading while allowing you to obtain the gauge published in the magazine.

To make a sample swatch on standard gauge machines cast on 60 stitches with waste yarn. Knit approximately 6 rows. *Mark the tension number for your swatch by making holes. For example 4 eyelet holes for Tension 4, 6 eyelet holes for Tension 6. Knit 6 more rows.

Change to garment yarn and reset row counter to 0. Knit 30 rows (in Pattern stitch). With contrast yarn, mark the 10th stitch FROM EACH SIDE by hand. Knit 30 Rows. Change to waste yarn and knit 6 rows. Change tension up or down for second section and repeat from *. Make third section with another tension. Remove on 12 Rows of waste yarn. Remove the sts. from the machine

by pushing the Carriage across without yarn.

Pull and stretch the swatch both lengthwise and diagonally from corner to corner. Gently block the swatch. Treat the swatch as you would the finished garment before measuring the gauge. For example, if you plan to wash this garment and dry it in the dryer, you should do so, measuring before and after to see the difference.

Measure between the stitches marked and the beginning and ending rows for the inches/cms. knitted. Divide the total number of stitches/rows by the inches measured to calculate sts. and rows per inch.

For Bulky knitters, make swatch with 30 Sts. and 30 Rows. If so desired, or for large pattern repeats, we suggest a wider and longer swatch to provide more accurate gauges.

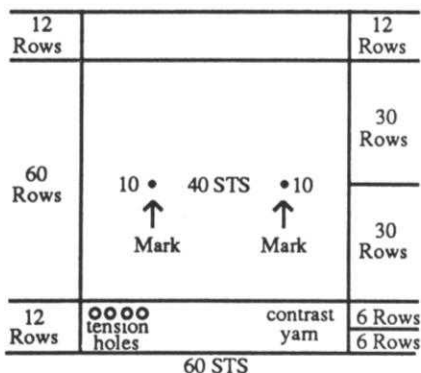

HEMS

Two methods of knitting hems are described below. Variations on these instructions will allow you to knit plain hems, picot edge hems and more.

Method One

With waste yarn cast on the required number of stitches and knit about 10-12 rows ending with the carriage on the left. Knit 1 Row to the right with Ravel Cord. Change to garment yarn and knit 1 Row to the left at garment body tension. (i.e. Skirt at Tension 4, 1st row at T 4). Turn tension down approximately 2 full tension numbers lower (tighter) and knit to mid point. (i.e. Row 14 of a 28-row hem). Change tension to 1 full point lower than garment body and knit remainder of hem rows. Pick up the stitches from the first row of garment yarn - shown between the stitches of Ravel Cord. Hem is now completed. Proceed with pattern as per chart and instruc-

tions. Remove waste yarn and Ravel Cord when you have completed section.

Method Two

Bring required number of needles to "B" (working) position. Attach cast-on comb. Beginning with the 2nd needle on the LEFT, bring every other needle to "D" or "E" position. Push in both Part buttons. Knit 1 Row to the left. Release the part buttons and drop the cast-on comb. (DO NOT REMOVE cast on comb from work). Knit required number of rows for hem. Attach weights to the back of work close to the cast-on comb (about 1/4" above the comb). Beginning with the 1st needle on the LEFT, bring every other needle to "D" position. Carefully LIFT the cast-on comb and hang loops onto the needles in "D" position. Turn the comb back away from you and make sure the needles are through the loops. Pull the needles out to "E" position and remove the cast-on comb.

BUTTONHOLES

The following methods of buttonholes are the general manner in which small and large buttonholes are created.

Small Buttonholes in Ribbing
Make small eyelet style buttonholes by following chart below.

Buttonhole Transfer
Center St. of Each Bed to Next St. of Other Bed



Large Buttonholes in FNR

Vertical buttonholes are made by knitting each side separately (partial or short-row knitting). Knit the right side first, end with yarn on left. Without breaking yarn, knit left side. The strand of yarn inside the buttonhole can be picked up every other row when knitting the left side, but this is not necessary for a small buttonhole.

SHORT ROWS

Method One

With carriage on opposite side start placing appropriate number of ndls in HP. Knit across and wrap the inside needle. Again, place appropriate number of ndls in HP on opposite side from carriage, knit across and repeat wrapping. The wrapping will eliminate any holes in the knitting.

Method Two - Automatic Wrap

Example follows for shoulder short rows. This method can be used for other Short Rowing as well. For example if pattern says to Short Row at shoulder every other row 7 sts, 1 x and 6 sts. 1 x . . . With carriage on opposite side put 6 sts in HP, knit 1 row across and put one additional needle in HP. Opposite carriage place 6 ndls in HP. Knit 1 row across and bring one extra needle to HP. Repeat until shortrowing is completed.

AT THE SAME TIME - Two functions are to be performed at the same time, such as shaping the neck and shoulder. Be sure to read both instructions before proceeding.

BO - Bind Off. To take off more than 1 St. at a time. When two or more stitches are to be bound off (or cast on) the carriage and yarn must be on the same side as the bind off. If the instruction is, "At R 100 BO 6 Sts on each side.", on the carriage side BO six stitches, knit one row and then bind off six stitches on the other side. See DECR and FF DECR.

BOLT - Slip Stitch Bind Off with a Latch Tool. Knit one row to the left at a tension at least five numbers higher (looser) than the garment tension. Bring all needles to holding position ("E") and then, pick up the first stitch on a latch tool allowing it to slip behind the latch, then pick up the next stitch and pull it through the stitch already on the latch hook, thus creating a slip stitch. If you cannot set the tension at least five full tension numbers higher, knit a row loosely manually.

CO - Cast on stitches for knitting. (**CHECK INSTRUCTION MANUALS TO MAKE SURE DIFFERENT METHODS ARE SHOWN**) In our instructions, CO is used either for a finished edge at the beginning of the garment, or to add edge stitch(es). If two or more stitches are to be cast on the carriage and yarn must be on the same side as the cast on. If the instruction is, "At R 100 CO 6 Sts on each side.", on the carriage side cast on six stitches, knit one row and then cast on six stitches on the other side.

COR - Carriage on Right

COL - Carriage on Left

DECR - Use the transfer tool to move the edge stitch(es) inward to the next needle. Usually used to transfer one edge stitch to the next needle, but may be used to transfer the two edge stitches to the next two needles.

EON - Every other needle

EOR - Every other row

EOS - Every other stitch

FF DECR - Used to make an even edge for seaming and decorative seams for raglans. If one stitch is to be decreased, use a two-prong transfer tool to move the two edge stitches inward one needle. If two stitches are to be decreased, use a three-prong transfer tool to move the three edge stitches in two needles. If three stitches are to be decreased, use two two-prong transfer tools and move the edge stitches in four needles. See DECR, BO and SHAPING.

FF INCR - To increase one stitch move the two edge stitches outward one needle, then fill the empty needle by picking up a bar from the row below and hanging it on the empty needle.

FNR - Full Needle Rib

G.C. - Garter Carriage

HP - Holding position or "E" position.

INCR - Increase. Usually used for "full-fashion" shaping, see FF Incr., or in conjunction with short row shaping. A simple incr can be made by pulling additional needle on side of carriage out to "E" position and knit across.

MB - Main Bed

MC - Main Color

Ndls - Needles

NWP - Non-working position or position "A"

R(s) - Row(s)

RB - Ribber Bed

RC - Row Counter.

RC 0 - Set RC to zero.

SET PATTERN - Follow the step-by-step instructions in your manual for setting the pattern and carriage controls for the pattern to be knit, e.g., Fairisle, tuck, single motif, etc.

SHAPING: The method used for shaping is a matter of personal preference. In our definitions we have described the methods commonly in use at Knitking. Which method is chosen for a particular pattern depends upon the garment, the yarn and the personal preference of the designer.

SHR - Short Row or Partial Knitting. Used for shaping shoulders, necklines, darts, gores, etc. Set carriage on H(old). **Every other row SHRs:** On the opposite side of the carriage, place the specified number of stitches in holding position, knit across, wrap the inner needle or use an "automatic wrap". After all specified stitches have been placed in HP change the carriage setting to N (knit) to return the needles to WP. **Every row SHRs:** On the side being shaped, place one stitch in HP every row. It is recommended you refer to your manual or an instruction book for detailed instructions about how to short row.

St(s) - Stitch(es)

St. St. - Stockinette stitch.

T - Tension.

WP - Working Position or "B" position.

WY - Waste yarn.

YM - Yarn marker. To place a yarn marker, use a short piece of contrasting yarn and loop it over the needle specified or the end needle of the row specified.

SEAMING GARMENTS

Any number of popular methods are suggested. We encourage you to experiment with any and all. If a garment in Knitking Magazine requires special seaming information it will be provided in the individual pattern instruction. Otherwise, methods include: linking on the knitting machine, Knitking's Lectrolink, the electric linker, crochet slip stitch, tapestry needles with back stitch sewing by hand. Bar to bar weaving for seamless appearance and seaming on a sewing machine.

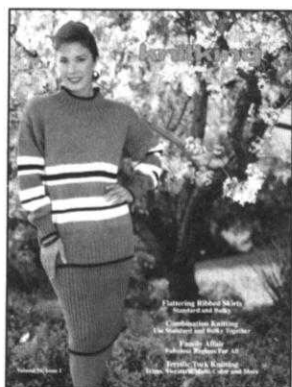

WOMENS TWO-PIECE with RIBBED SKIRT

YARN: Alpine and Woolana
SIZES:

6/8 (10/12) [14]

AMOUNT:

Skirt: Col. 1 - Woolana -Olive:
1 lb. (1 lb.) [1-1/2 lb.]

Top:

Col. 1: Woolana - Olive
1 lb. (1 lb.) [1 lb. 4 oz.]

Col. 2: Alpine - Bronze
4 oz. all sizes

Col. 3: Alpine - Cream
3 oz. all sizes

Col. 4: Alpine - Black
2 oz. all sizes

Col. 5: Alpine - White
2 oz. all sizes

KIT PRICE:

\$73.00 (\$73.00) [\$95.00]

TENSION:

Body: Woolana: T 2

Alpine: T 1.2

Skirt: See chart

Rib: T-0/-0 I

GAUGE:

Body: 4.78 Sts., 7.65 Rs. = 1"

Skirt: 6.47 Sts., 7.77 Rs. = 1"

NOTIONS:

Elastic for skirt waistband.

Make on any Bulky Machine with Ribber.

BACK:

With WY CO 90 (100) [110] sts. After several rows, end with 1 row Ravel Cord to the right. Change to Col. 1 (4 strands). RC 0. T 2. Knit in st. st. following color chart. At R 84 (88) [96] shape armhole. On each side decr. EOR 1 St. 4x. At R 152 (160) [168] shape neckline. Place center 32 (34) [36] sts. in HP and all sts. to the left. *On neckline edge SHR EOR 1 St. 3x. AT THE SAME TIME SHR shoulder EOR 5 St. 4x. At R 160 (168) [176] remove shoulder sts. on WY. Reset RC to

152 (160) [168]. Shape left neckline and shoulder same as right from *, reversing shaping. Remove shoulder and neckline sts. on separate WY.

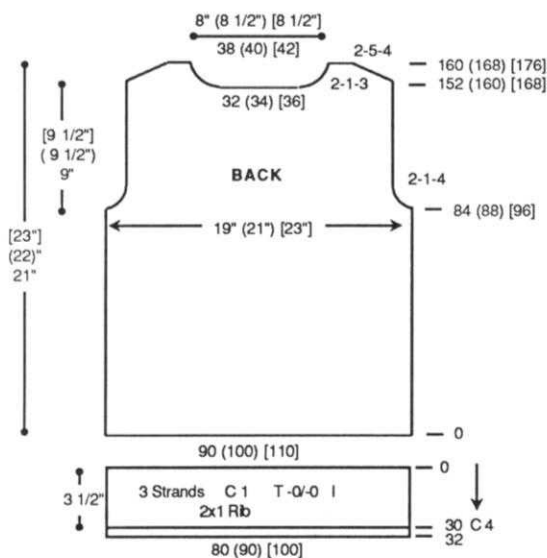

BODY & SLEEVE

COLOR CHART

Repeat	Rows	Colors	
↑	8	C 3	
	6	C 4	
	4	C 3	
	6	C 2	
	12	C 1 4 Strnds	
	10	C 5	
	4	C 4	
	10	C 3	
	10 (12) [14]	C 2	
	12 (14) [16]	C 1 4 Strnds	
		Rows	Colors

FRONT:

Knit front same as back to R 134 (142) [150]. Shape neckline. Place center 14 (16) [18] sts. in HP and all sts. to the left. *On neckline edge SHR EOR 2 Sts. 2x and 1 St. 8x. At R 152 (160) [168] SHR shoulder EOR 5 Sts. 4x. At R 160 (168) [176] remove shoulder sts. on WY. Reset RC to 134 (142) [150]. Shape left neckline and shoulder same as right from *, reversing shaping. Remove shoulder and neckline sts. on separate WY.

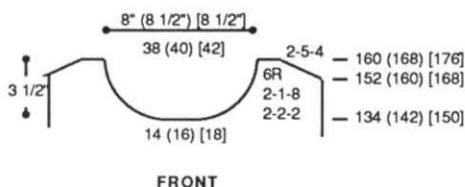

WAISTBAND:

With purl side facing rehang lower edge of front/back on 80 (90) [100] ndls. for 2 x 1 Rib as shown on ndl. chart. RC 0. T -0/-0 I. Col. 1 (3 strands). Knit to R 30 and change to Col. 4 (1 strand). Knit to R 32, knitting last row at T 8/4. Transfer RB sts. to MB and BOLT.

SLEEVE:

Make 2 the same. With WY CO 56 [(60)] sts. After several rows, end with 1 row Ravel Cord to the right. Change to Col. 1 (4 strands). RC 0. T 2. Knit in st. st. following color chart. while incr. on each side every 6 Rs. 1 St. 12 [(11)] x and every 7 Rs. 1 St. 4 [(6)] x. At R 110 [(114)] SHR sleeve cap on each side EOR 2 Sts. 4x. At R 118 [(122)] knit 1 R at T 10 and BOLT.

SLEEVE CUFF:

With purl side facing rehang lower edge of sleeve on 42 [(42)] ndls. for 2 x 1 Rib as shown on ndl. chart. RC 0. T -0/-0 I. Col. 1 (3 strands). Knit to R 26 and change to Col. 4 (1 strand). Knit to R 28, knitting last row at T 8/4. Transfer RB sts. to MB and BOLT.

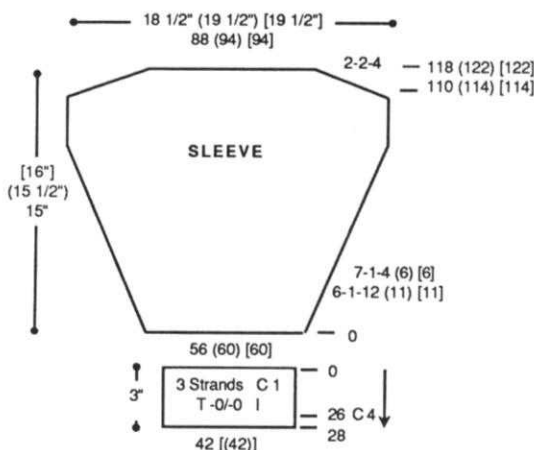

NECKBAND

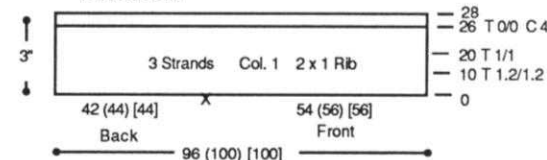

NECKBAND:

With purl side facing, pick up 96 [(100)] sts. for 2 x 1 Rib as shown on chart. RC 0. T 1.2/1.2. Col. 1 (3 strands).

(continued next page)

(continued from previous page)

Knit to R 10. Change to T 1/1 and knit to R 20. Change to T 0/0 and knit to R 26. Change to Col. 4 (1 strand) and knit to R 28, knitting last row at T 8/4. Transfer Rb sts. to MB and BOLT.

SKIRT FRONT/BACK:

Make 2 the same.

Skirt is knit from top down. With WY CO 104 [(110)] sts. for 2 x 1 Rib. After several rows, end with 1 row Ravel Cord to the right. RC 0. T 0.2/0.2 (0.2/0.2) [1/1] I. Col. 1 (3 strands). Knit to R 40 and change to T 1.1/1.1 (1.1/1.1) [2/2]. Knit to R 148 and change to T 0.2/0.2 (0.2/0.2) [1/1]. Knit to R 160 and change to T 0/0 (0/0) [0.2/0.2]. Knit to R 168 (178) [188] and change to

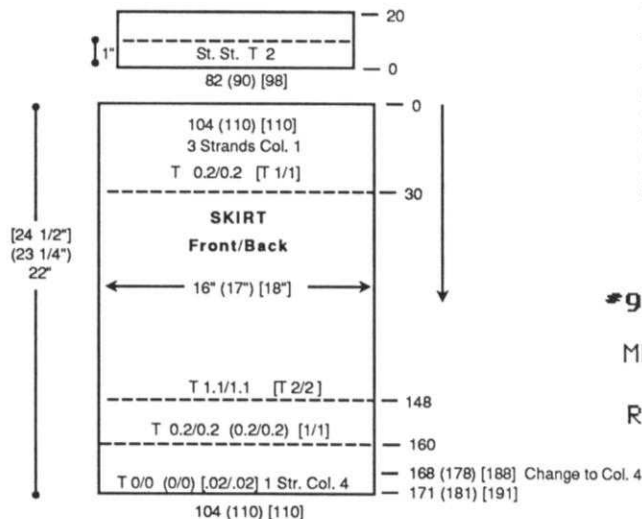

Col. 4 (1 Strand). Knit to R 171 (181) [191], knitting last R at T 8/4. Transfer RB sts. to MB and BOLT.

WAISTBAND:

With knit side facing rehang upper edge of skirt front/back on 82 (90) [98] ndls. for St. St. RC 0. T 2. Col. 1 (3 strands). Knit to R 20. Pick up sts. from first row form hem. Knit 1 row at T 10 and BOLT.

*977 Needle Arrangement



FINISHING:

Close all seams. Do not stretch ribbing on skirt when you steam it.

978



TUCK SWEATER with SPECIAL SHORT ROW CUFF

YARN: Primo

SIZES:

6/8 (10/12) [14]

AMOUNT:

Col. 1: Red

1-1/2 lbs. all sizes

KIT PRICE: \$28.00

TENSION:

Tuck: T 6.1

St. St.: T 5

GAUGE:

Tuck: 7.5 Sts., 16 Rs. = 1"

St. St.: 8 Sts., 14 Rs. = 1"

NOTIONS:

9 - 3/8" Buttons

Make on Standard 24-Stitch Punch Card or Standard Electronic Machine.

BACK:

With WY CO 76 (80) [84] sts. to the right of -0-. After several rows, end with 1 row Ravel Cord to the left. T 6.1. Tuck Pattern. Knit 1 R to set pattern. RC 0. Knit to R 146 and remove sts. on WY. With WY CO 76 (80) [84] sts. to the left of -0- and work the same as first section to R146. With purl side facing rehang the first section. There will be a total of 152 (160) [168] sts. Knit to R 248 (256) [264] and mark each side with YM for armhole. Knit to R 392 (408) [424] and mark

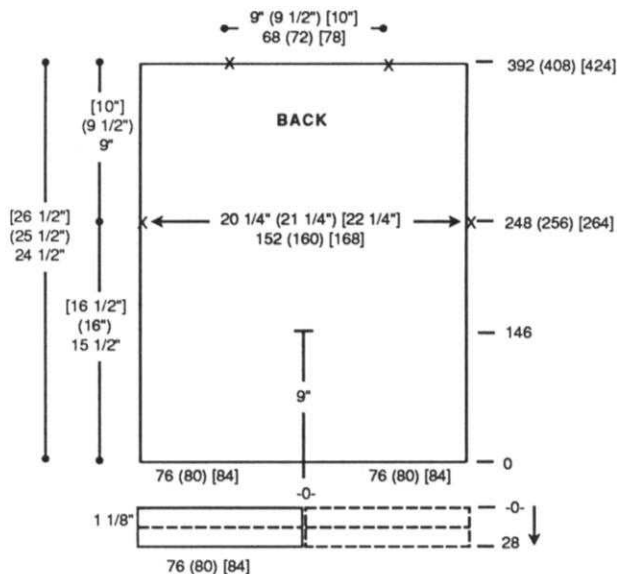

BACK OPENING (Make 2)

T 5 St. St.

14

80

0

o - Button Placement

center 68 (72) [78] sts. for neck opening. Remove shoulder and neckline sts. on separate sections of WY.

BACK HEM: Make 2.

With knit side facing, rehang left/right lower edge of back on 76 (80) [84] ndls. RC 0. T 5. St. St. Knit to R 28 and pick up first row to form doubled hem. Knit 1 R at T 10 and BOLT.

BACK OPENING: Make 2.

With knit side facing, rehang back opening on 80 ndls. RC 0. T 5. St. St. Knit to R 14 and pick up first row to form doubled band. Knit 1 R at T 10 and BOLT.

FRONT:

With WY CO 152 (160) [168] sts. After several rows, end with 1 row Ravel Cord to the left. T 6.1. Tuck Pattern. Knit 1 R to set pattern. RC 0. Knit to R 248 (256) [264] and mark each side with YM for armhole. Knit to R 360 (378) [392] and shape neckline. Note pattern row. Place center 36 (40) [46] sts. in HP and all sts. to the left in HP. *On neckline edge SHR every R 1 St. 8x and EOR 1 St. 8x. At R 392 (408) [424] remove shoulder sts. on WY. Reset RC to R 360 (378) [392]. Reset pattern to correct row. Shape left neckline same as right from *. Remove shoulder and neckline sts. on separate WY.

FRONT HEM:

With knit side facing, rehang lower edge of front on 152 (160) [168] ndls. RC 0. T 5. St. St. Knit

to R 28 and pick up first row to form doubled hem. Knit 1 R at T 10 and BOLT.

Sleeve Short Row Chart
R # N # R # N #

14	L21	164	L21
24	L21	174	L21
34	R10	184	R28
44	L21	194	L21
54	L21	204	L21
64	R28	214	R10
74	L21	224	L21
84	L21	234	L21
94	R10	244	R28
104	L21	254	L21
114	L21	264	L21
124	R28	274	R10
134	L21	284	L21
144	L21		
154	R10		

294 L21 size (10/12) [14]
304 R28 size [14] only

SLEEVE CUFF: Make 2.
With knit side facing, rehang lower edge of sleeve on 56 (64) [70] ndls. RC 0. T 5. St. St. Knit to R 14 and pick up first row to form doubled band. Knit 1 R at T 10 and BOLT.

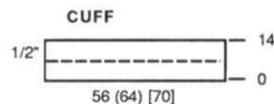

NECKBAND:

Close one shoulder. With knit side facing, rehang back/front neckline on 140 (146) [152] ndls. following chart. RC 0. T 5. St. St. Knit to R 14 and pick up first row to form doubled band. Knit 1 R at T 10 and BOLT.

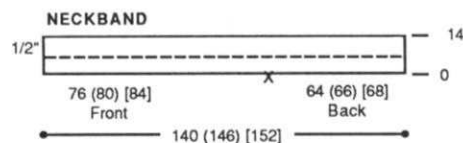

#978 Tuck Pattern
24 Sts. x 10 Rows

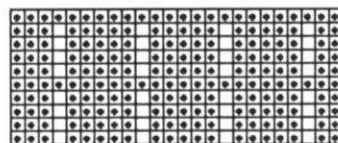

KK Magazine Disk: Tr 1; #901

FINISHING:

Close all remaining seams. Sew buttons on back opening following chart.

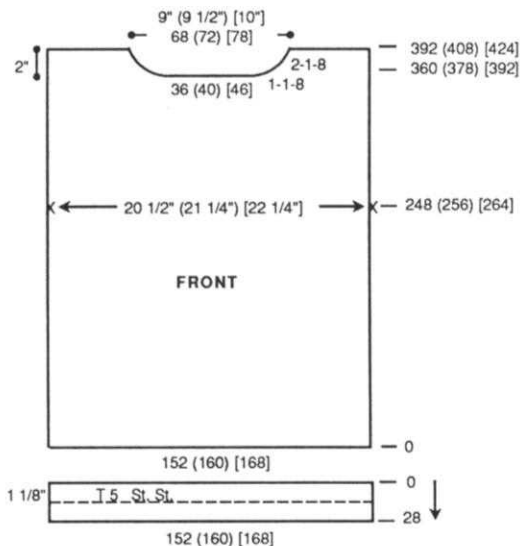

SLEEVE:

Make 1, Reverse 1.
With WY CO 168 sts. After several rows, end with 1 row Ravel Cord to the left. T 6.1. Tuck Pattern. Knit 1 R to set pattern. RC 0. Knit to R 14. *Put all sts. to the left of ndl. 21 (left of -0-) to HP. Knit 4 Rs. Release HOLD button and knit to R 24. Repeat from * following short row chart for row # and ndl. #. At R 144 (152) [160] mark right side with YM for center. Continue to R 288 (304) [320] and remove sts. on WY.

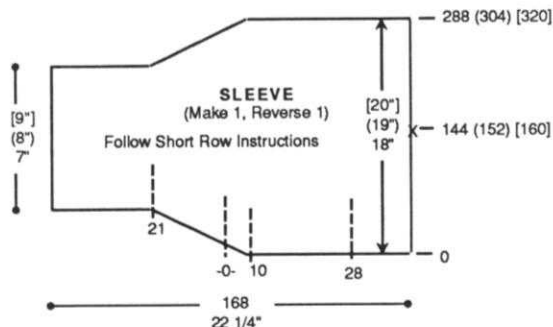

Garter Carriage Knits Ribbing Automatically . . . and More!

The Knitting Garter Carriage makes knitting Ribbing a breeze. With the press of a button, the Garter Carriage moves across your knitting machine *on its own power!* You can leave the room and your ribbing will be finished when you return!

But ribbing is only the beginning of the story: The Garter Carriage automatically casts on, binds off and knits a *multitude of fancy Garter Stitch patterns*—beautiful, textured 3-dimensional designs impossible to knit any other way.

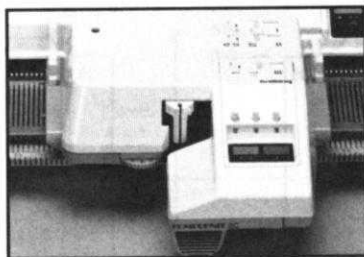

- Select desired pattern on knitting machine.
- Set number of rows; switch GC on and leave to do other things.
- It will turn off after completion or if yarn runs out or breaks.
- Available for all standard COMPUKNITS and most standard Knitting punch card knitters going all the way back to the KH-840.

Order yours now from your local Knitting Dealer, or if there are none in your area, from:



1128 Crenshaw Boulevard • Los Angeles, CA 90019 • Phone: (213) 938-2077



TWO-PIECE ENSEMBLE
with OVERSIZED TOP
AND MINI SKIRT

YARN: Woolana and Venetia
SIZES:

6/8 (10/12) [14]
AMOUNT:

- Col. 1: Woolana - Red
14 oz. all sizes
- Col. 2: Woolana - Amethyst
6 oz. all sizes
- Col. 3: Venetia - Toast
12 oz. all sizes
- Col. 4: Venetia - Sand Frost
8 oz. all sizes
- Col. 5: Venetia - Jungle
6 oz. all sizes

KIT PRICE: \$82.00

TENSION:

Fairisle: T 5
Bands: T 3

GAUGE:

Fairisle: 9 Sts., 10.5 Rs. = 1"

NOTIONS:

Elastic for skirt waistband.

Make on Standard 24-Stitch
Punch Card Machine or Standard
Electronic Machine.

LEFT FRONT:

With Col. 1 CO 110 (118) [128] sts. T 3. St. St. Knit to R 18. Pick up sts. from first row to form double hem. T 5. Pattern #3. Col. 1. Knit 1 R to set ndls. Add Col. 3 in 'B' feeder. RC 0. Knit to R 94. Change to Pattern 1. Following color chart knit to R 101. Change to Pattern #2. Col. 4 in 'A' Feeder and Col. 2 in 'B' Feeder. Knit to R 210. Shape neckline. On right side BO 24 sts. then decr. every R 1 St. 6x and EOR 1 St. 12x. At R 241 change to Pattern #1. Following color chart knit to R 248 and remove shoulder sts. on WY.

RIGHT FRONT:

With Col. 4 CO 110 (118) [128] sts. T 3. St. St. Knit to R 18. Pick up sts. from first row to form double hem. T 5. Pattern #2. Col. 4. Knit 1 R to set ndls. Add Col. 2 in "B" Feeder. RC 0. Knit to R 94. Change to Pattern #1. Following color chart knit to R 101. Change to Pattern #3. Col. 1 in 'A' Feeder and Col. 3 in 'B' Feeder. Knit to R 210. Shape neckline. On left side BO 24 sts.

then decr. every R 1 St. 6x and EOR 1 St. 12x. At R 241 change to Pattern #1. Following color chart knit to R 248 and remove shoulder sts. on WY.

RIGHT BACK:

With Col. 4 CO 110 (118) [128] sts. T 3. St. St. Knit to R 18. Pick up sts. from first row to form double hem. T 5. Pattern #2. Col. 4. Knit 1 R to set ndls. Add Col. 2 in "B" Feeder. RC 0. Knit to R 94. Change to Pattern #1. Following color chart knit to R 101. Change to Pattern #3. Col. 1 in "A" Feeder and Col. 3 in "B" Feeder. Knit to R 240. Shape neckline. On right side BO 35 sts. then decr. every R 1 St. 7x. AT THE SAME TIME AT R 241 change to Pattern #1. Following color chart knit to R 248 and remove shoulder sts. on WY.

LEFT BACK:

With Col. 1 CO 110 (118) [128] sts. T 3. St. St. Knit to R 18. Pick up sts. from first row to form double hem. T 5. Pattern #3. Col. 1. Knit 1 R to set ndls. Add Col. 3 in "B" Feeder. RC 0. Knit to R 94. Change to Pattern #1. Following color chart knit to R 101. Change to Pattern #2. Col. 4 in 'A' Feeder and Col. 2 in 'B' Feeder. Knit to R 240. Shape neckline. On left side BO 35 sts. then decr. every R 1 St. 7x. AT THE SAME TIME AT R 241 change to Pattern #1. Following color chart knit to R 248 and remove shoulder sts. on WY.

LEFT SLEEVE:

With WY CO 110 (118) [128] sts. After several rows, end with 1 R Ravel Cord to the left. T 5. Pattern #2. Col. 4. Knit 1 R to set ndls. Add Col. 2 in "B" Feeder. RC 0. Shape sides by incr. every 6 Rs. 1 St. 31x. At R 190 (200) [210] knit 1 row at T 10 and BOLT.

LEFT SLEEVE CUFF:

With purl side facing, rehang lower edge of sleeve on 66 (72) [80] ndls. RC 0. T 3. Follow color chart knit to R 15. Change to Col. 3 and knit to R 36. Pick up first row to form doubled band. Knit 1 row at T 10 and BOLT.

RIGHT SLEEVE:

With WY CO 162 (170) [180] sts. After several rows, end with 1 R Ravel Cord to the left. T 5. Pattern #3. Col. 1. Knit 1 R to set ndls. Add Col. 3 in "B" Feeder. RC 0. Knit in fairisle while SHR

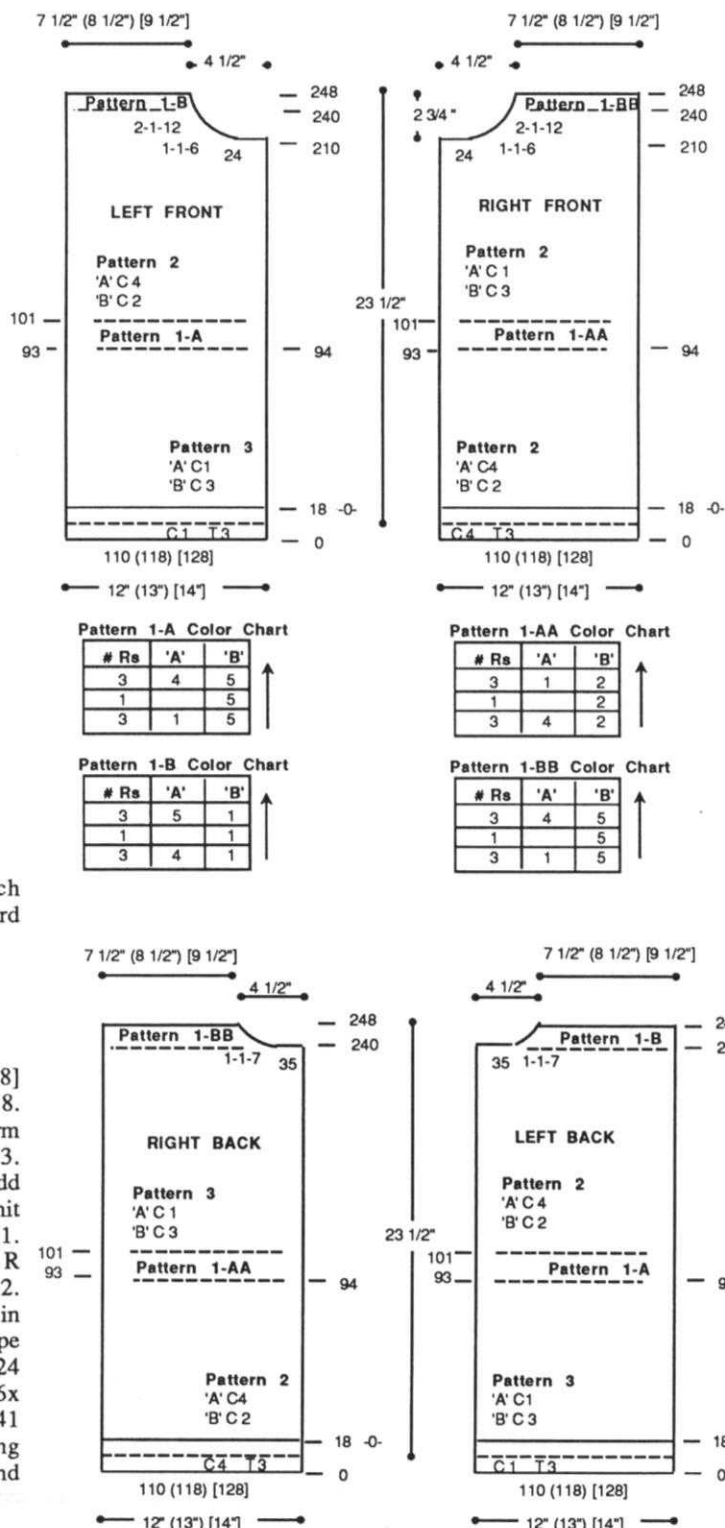

shaping on the right side EOR 9 Sts. 18x (9 Sts. 10x and 10 Sts. 8x) [10 Sts. 18x]. At R 164 (174) [184] begin SHR shaping on the right side EOR 9 Sts. 18x (9 Sts. 10x and 10 Sts. 8x) [10 Sts. 18x]. At R 200 (210) [220] remove sts. on WY.

RIGHT SLEEVE CUFF:

With purl side facing, rehang lower edge of sleeve on 66 (72) [80] ndls. RC 0. T 3. Follow color chart knit to R 15. Change to Col. 2 and knit to R 36. Pick up first row to form doubled band. Knit 1 row at T 10 and BOLT.

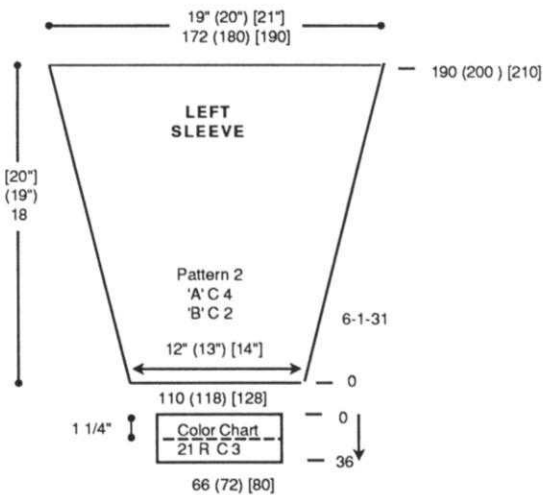

Left Sleeve Cuff Color Chart

# Rs	'A'	'B'
3	3	5
1		5
3	1	5
4	4	
2	5	
2	2	

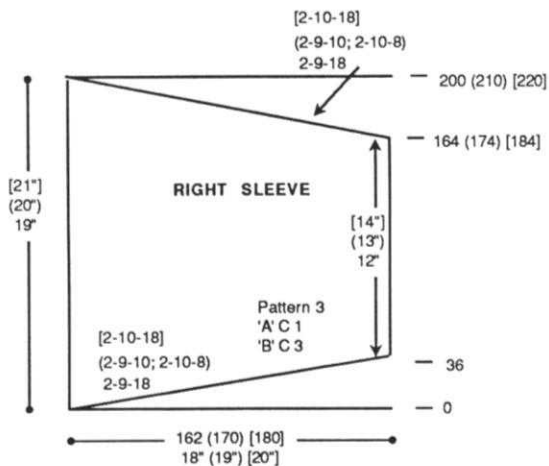

Right Sleeve Cuff

# Rs	'A'	'B'
3	2	5
1		5
3	4	5
4	4	
2	5	
2	2	

Right Sleeve Cuff Color Chart

# Rs	'A'	'B'
3	2	5
1		5
3	4	5
4	4	
2	5	
2	2	

FRONT NECKBAND:

Join front center seam. With purl side facing, rehang front neckline on 100 ndls. RC 0. T 3. Pattern #1 Following color chart knit to R 19. Change to Col. 5 and knit to R 36. Pick up first row to form doubled band. Knit 1 row at T 10 and BOLT.

FRONT NECKBAND
See Hem & Neckband Color Chart

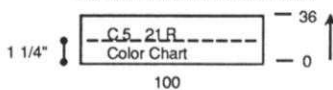

BACK NECKBAND:

Join back center seam. With purl side facing, rehang back neckline on 72 ndls. Knit same as Front Neckband.

BACK NECKBAND
See Hem & Neckband Color Chart

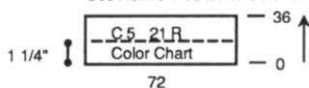

SKIRT: Make 2 the same.

With WY CO 160 (170) [180] sts. After several rows, end with 1 R Ravel Cord to the left. T 5. Pattern #3. Col. 1. Knit 1 R to set ndls. Add Col. 3 in "B" Feeder. RC 0. Knit to R 130 (140) [150]. Decr. on each side every 10 Rs. 1 St. 5x. At R 190 (200) [210] remove sts. on WY.

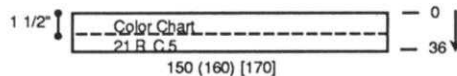
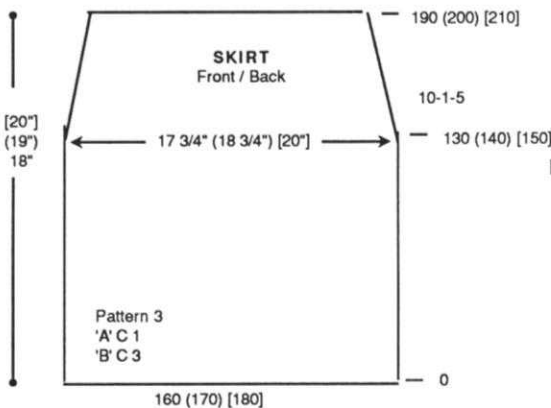
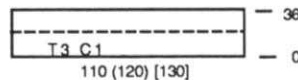

Skirt Hem and Neckband Color Chart

# Rs	'A'	'B'
3R	C5	C2
1R		C2
3R	C3	C2
4R	C3	
2R	C2	
2R	C5	

SKIRT HEM:

With purl side facing, rehang lower edge of skirt front/back on 150 (160) [170] ndls. decr. evenly across. RC 0. T 3. Follow color chart knit to R 15. Change to Col. 5 and knit to R 36. Pick up first row to form doubled band. Knit 1 row at T 10 and BOLT.

#979 Fairisle Pattern 1
24 Sts. x 7 Rows



KK Magazine Disk: Tr 2; #901

#979 Fairisle Pattern 2
24 Sts. x 60 Rows

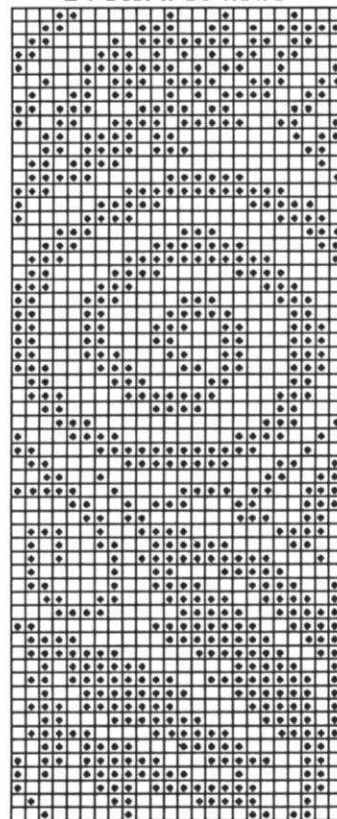

KK Magazine Disk: Tr 2 #902

#979 Fairisle Pattern 3
24 Sts. x 6 Rows

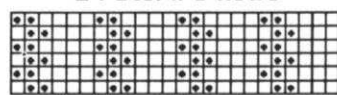

KK Magazine Disk: Tr 2; #903

SKIRT WAISTBAND: Make 2.

With purl side facing rehang upper edge of skirt front/back on 110 (120) [130] ndls. decr. evenly across. RC 0. T 3. Col. 1. Knit to R 36. Pick up sts. from first row to form hem. Knit 1 row at T 10 and BOLT.

FINISHING:

Close all seams.

(continued from previous page)

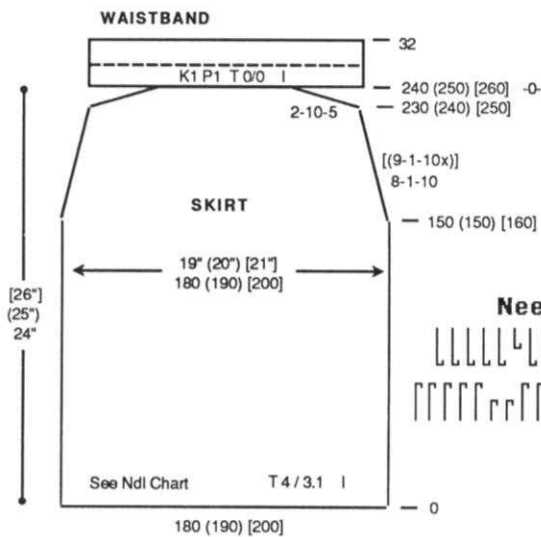

SKIRT: Make 1, Reverse Ndl. Arrangement on 1. With Col. 3 CO 180 (190) [200] sts. for FNR. After selvedge RC 0. T 4/3.1 I. Arrange ndls. as shown on chart. Knit to R 150 (150) [160]. Begin decr. on each

side every 8 Rs. 1 St. 10x [(every 9 Rs. 1 St. 10x)]. At R 230 (240) [250] SHR shape on each side EOR 10 Sts. 5x. At R 240 (250) [260] arrange ndls. for K1/P1 Rib. RC 0. T 0/0 I. Knit to R 32. Transfer RB sts. to MB. Knit 1 row at T 10 and BOLT.

***980 Skirt Pattern**

Needle Set Up - Make 1, Reverse 1

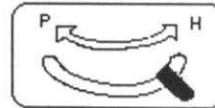

FINISHING:

Close all seams. Fold Skirt Wasitband and Pullover bands to inside and whip stitch in place.



Compuknit/ST

The Fun of Electronic Knitting . . . At a Price that's Easy on Your Wallet!

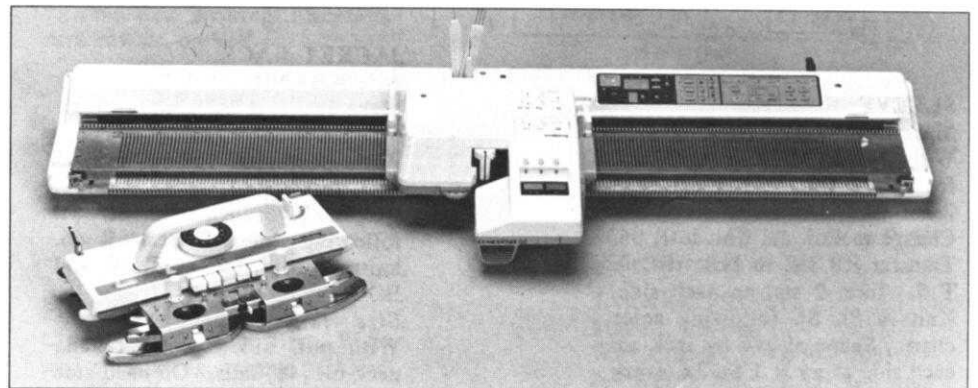

Compuknit/ST shown with Main Carriage and optional Garter Carriage

- Standard Gauge knitter with 200 stainless-steel needles
- 50 built-in patterns including Tuck, Skip, Fair Isle, Weaving, Plating, and Thread Lace designs
- Also Includes built-in Garter Stitch and Normal and Fine Lace patterns (Lace and Garter Carriages optional)
- Additional memory for storing user-inputted patterns from 1 to 24 stitches wide and over 1000 rows long
- Like all Compuknits, original creations can also be entered via the Pattern Design Computer and/or Disk Drive
- Variation keys for double-long, upside-down, pattern reverse, yarn color reverse and more

The full-feature Compuknit/ST is the only electronic knitter available today for under \$1,000



Available through your local KNITKING dealer. Or, if there is no dealer in your area, from:

1128 Crenshaw Blvd. • Los Angeles, California, 90019 • Phone (213) 938-2077



BULKY INTARSIA WEAVING PULLOVER

YARN: Alpine and Caprinae
SIZES:

Small (Medium) [Large]

AMOUNT:

Col. 1: Alpine-Black
1 lb. all sizes

Caprinae - 1 oz. all sizes

Col. 2: Grey Taupe

Col. 3: Fuschia

Col. 4: Tan

Col. 5: Jade

Col. 6: Cream

Col. 7: Royal

Col. 8: Silver

Col. 9: Turquoise

Col. 10: Purple

Col. 11: Red

Col. 12: Knit-in Elastic-Black

1 spool all sizes

KIT PRICE: \$55.00

TENSION:

Body: T: 6

GAUGE:

Body: 3.84 Sts., 5.33 Rs. = 1"

Make on compuknit/Bulky or Punch Card Bulky with Ribber.

Note: Size Small fits as oversized pullover for Pre-teen Small or Childrens Size 14.

Intarsia Weaving Pattern:

1. Attach weaving brushes. Select KC. With Col. 1 knit 1 row to set pattern.
2. Lay contrast color over ndls. in 'D' position, making sure latches are open.
3. Knit 1 row.
4. Repeat steps 2 and 3 to end.

BACK:

With WY CO 76 (80) [84] sts. After several rows, end with 1 row Ravel Cord to the left. Change to Col. 1. RC 0. T 6. Intarsia Weaving. Following Chart knit to R 66 (70) [74]. Shape armhole. On each side BO 4 sts.

then decr. every row 1 St. 1x. At R 120 (126) [130] SHR shoulders. On each side SHR EOR 7 Sts. 2x and 6 St. 1x. After R 126 (132) [136] remove shoulder sts. on WY. Incr. 2 sts. each side for a total of 30 (30) [34] sts. With Col. 1 knit 1 row. Transfer EOS to RB for K1/P1 Rib. RC 0. T 3/3 I. Knit to R 18, knitting last row at T 10/8 and BOLT.

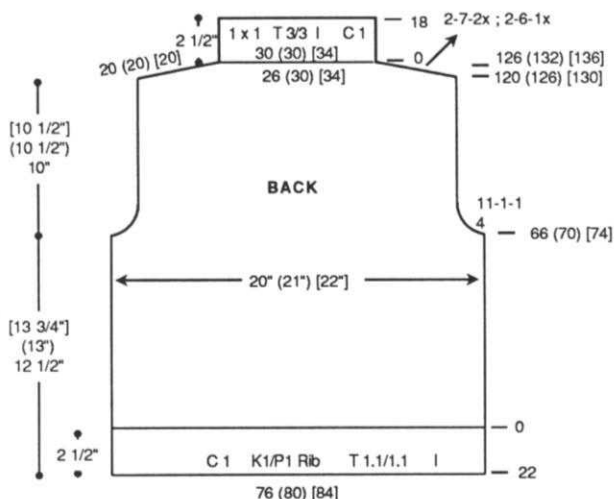

FRONT:

Knit front same as back reversing colors so the color matches at seam. At R 100 (106) [110]. Shape neckline. Place center 10 (14) [18] sts. in HP and all sts. to the left. *Note pattern row.* *SHR neckline edge EOR 1 St. 8x. At R 120 (126) [130] SHR shoulder EOR 7 Sts. 2x and 6 St. 1x. Remove shoulder sts. on WY. Reset RC to R 100 (106) [110] and reset pattern to appropriate row. Shape left neckline and shoulder from *, reversing shapings. Place neckline sts. in WP. Pick up sts. from each side to make a total of 44 (44) [48] sts. Knit 1 R. RC 0. T 3/3 I. Place all sts. in HP except center 4 sts. Transfer EOS to RB for 1 x 1 Rib. Knit 1 R. *Opposite carriage put 4 Sts. to WP and transfer appropriate ndls. to RB. Knit 1 R. Repeat from * 5x. RC 0. Knit to R 18, knitting last row at T 10/8 and BOLT.

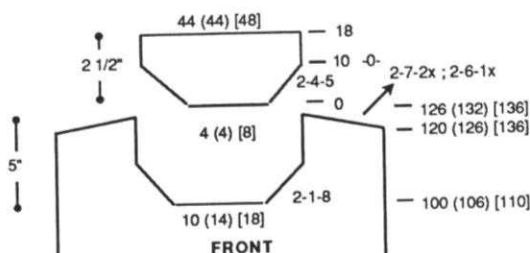

Front/Back Intarsia Weaving Color Chart Reverse Colors for Front

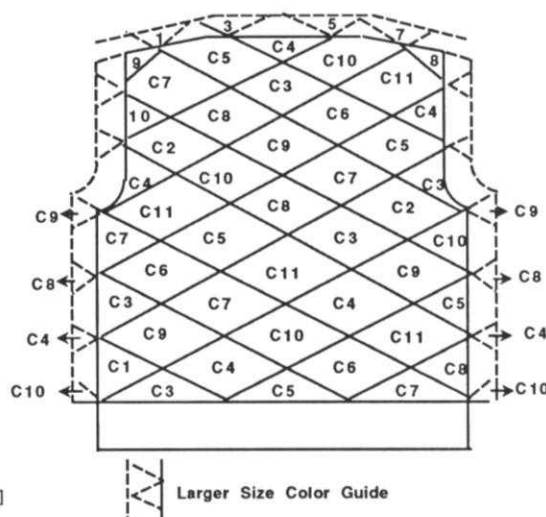

SLEEVE:

Make 2 the same. With WY CO 52 (52) [56] sts. After several rows, end with 1 row Ravel Cord to the left. Change to Col. 1. RC 0. T 6. Intarsia Weaving. Follow Chart while incr. on each side every 6 Rs. 1 St. 6x and every 7 Rs. 1 St. 4x (every 5 Rs. 1 St. 14x) [every 6 Rs. 1 St. 13x]. At R 70 (74) [80] SHR sleeve cap on each side EOR 5 Sts. 6x. At R 82 (86) [92] knit 1 R over all sts. Mark center and remove sts. on WY

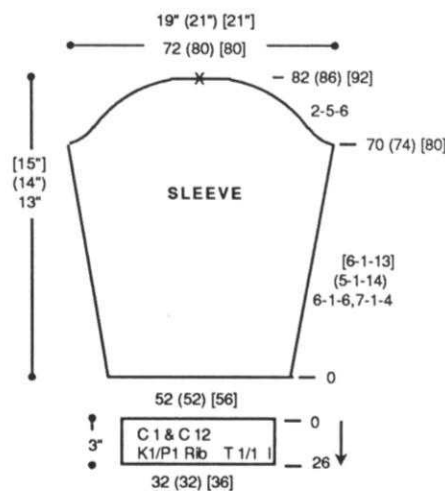

(continued next page)

(continued from previous page)

Sleeve
Intarsia Weaving
Color Chart

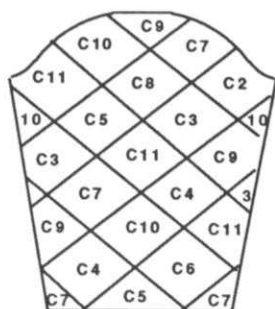

SLEEVE CUFF:

With purl side facing, rehang lower edge of sleeve on 32 (32) [36] ndls. With Col. 1 and Col. 12 knit 1 R. Transfer EOS to RB for K1/P1 Rib. RC 0. T 1/1 I. Knit to R 26, knitting last row at T 10/8 and BOLT.

FINISHING:

Close all seams.

#981 Intarsia Weaving
24 Sts. x 44 Rows

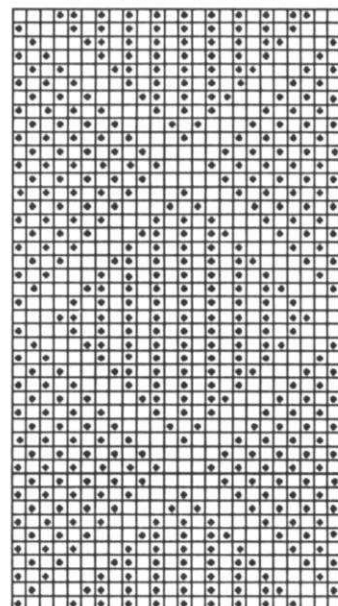

KK Magazine Disk: Tr 4; #901

982



BULKY SHORT CARDIGAN JACKET

YARN: Primo and Wings

SIZES: 6/8 (10/12) [14/16]

AMOUNT:
Col. 1: Black Primo
20 oz. (24 oz.) [24 oz.]

Col. 2: Black Rainbow Wings
7 oz. (8 oz.) [10 oz.]

KIT PRICE:
\$60.00 (\$68.50) [\$78.50]

TENSION:
Body: T 7.2
Rib: 0/0 I

GAUGE:
Body: 4.1 Sts., 5.59 Rs. = 1"

Make on any Bulky Machine with Ribber.

BACK:

With WY CO 90 (98) [106] sts. After several rows, end with 1 row Ravel Cord to the right. RC 0. T 7.2. Col. 1 (2 strands) and Col. 2 (1 strand). Knit to R 60 (70) [76] and shape armhole. On each side BO 5 sts., decr. every 4 Rs. 1 St. 4x and every 6 Rs. 1 St. 2x. At R 102 (114) [124] SHR shoulders EOR 6 Sts. 3x. At R 110 (120) [132] mark center 26 (28) [30] sts. for neck opening and remove shoulder and neckline sts. on separate WY.

BACK WAISTBAND:

With purl side facing rehang lower edge of back on 84 (92) [100] ndls. Knit 1 row to the left. Transfer EOS to RB. RC 0. T 0/0 I. Col. 1 (3 strands). Knit

to R 24 making cables at R 4, 12, and 20 (see chart). Knit 1 row at T 8/4. Transfer RB sts. to MB and BOLT.

FRONT: Make 1, Reverse 1.

With WY CO 46 (50) [54] sts. After several rows, end with 1 row Ravel Cord to the right. RC 0. T 7.2. Col. 1 (2 strands) and Col. 2 (1 strand). Knit to R 26 (34) [42] and shape neckline. On left side decr. every 4 Rs. 1 St. 4 (5) [6] x and every 6 Rs. 1 St. 10 [(10)] x. AT THE SAME TIME at R 60 (70) [76] shape armhole. On right side BO 5 sts., decr. every 4 Rs. 1 St. 4x and every 6 Rs. 1 St. 2x. At R 102 (114) [124] SHR shoulder EOR 6 Sts. 3x. At R 110 (120) [132] remove shoulder sts. on WY.

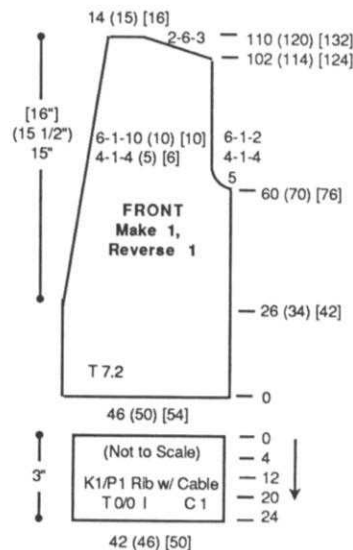
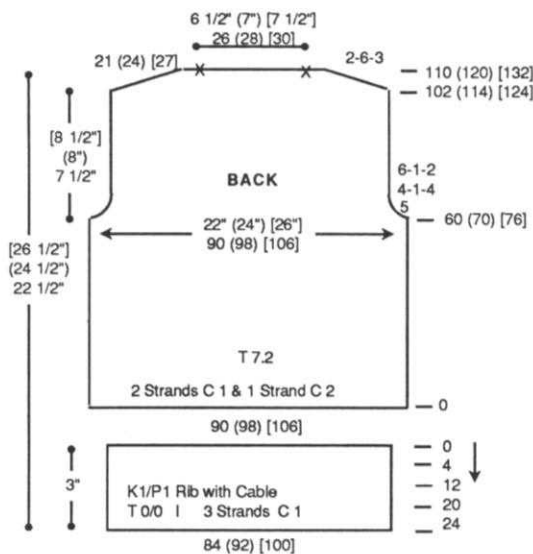

FRONT WAISTBAND:

With purl side facing rehang lower edge of front on 42 (46) [50] ndls. Knit 1 row to the left. Transfer EOS to RB. RC 0. T 0/0 I. Col. 1 (3 strands). Knit to R 24 making cables same as back. Knit 1 row at T 8/4. Transfer RB sts. to MB and BOLT.

SLEEVE:

Make 2 the same. With WY CO 50 (54) [58] sts. After several rows, end with 1 row Ravel Cord to the right. RC 0. T 7.2. Col. 1 (2 strands) and Col. 2 (1 strand). Shape sleeve by incr. every 7 Rs 1 St. 2 x and every 8 Rs 1 St. 8x (every 8 Rs 1 St. 1 x and every 9 Rs 1 St. 8 x) [every 10 Rs 1 St. 4 x and every 11 Rs 1 St. 4 x]. At R 78 (80) [84] shape cap. On each side BO 5 Sts., decr. EOR 1 St. 10x and every row 1 St. 6x. At R 104 (106) [110] knit 1 row at T 10 and BOLT.

SLEEVE CUFF:

With purl side facing rehang lower edge of sleeve on 40 (40) [42] ndls. Knit 1 row to the left. Transfer EOS to RB. RC 0. T 0/0 I. Col. 1 (3 strands). Knit to R 24 making cables at R 4, 12 and 20 (see chart). Knit 1 row at T 8/4. Transfer RB sts. to MB and BOLT.

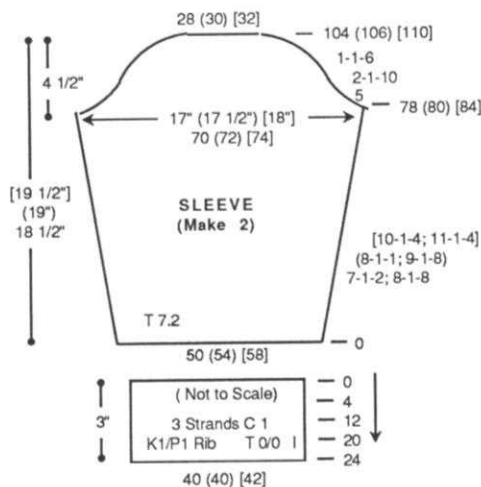

BACK NECKBAND

Close both shoulders. With purl side facing rehang back neckline on 26 (28) [30] ndls. as shown on chart. Knit 1 row to the left. Transfer EOS to RB. RC 0. T 0/0 I. Knit to R 16 making cables at R 4 and 12 (see chart). Knit 1 row at T 8/4. Transfer RB sts. to MB and BOLT.

BACK NECKBAND (Make 1)

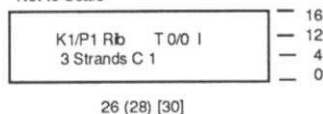

FRONT BAND (Make 2)

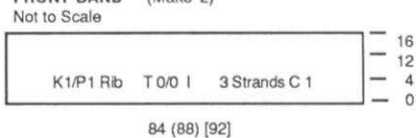

FRONT BAND: (Make 2)

With purl side facing rehang front on 84 (88) [92] ndls. Knit 1 R to the left. Transfer EOS to RB. RC 0. T 0/0 I. Knit to R 16 making cables at R 4 and 12 (see chart). Knit 1 R at T 8/4. Transfer RB sts. to MB and BOLT.

*982 Bulky Cardigan Jacket Bands Needle And Cable Chart Arrangement

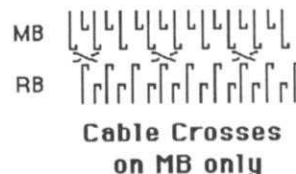

FINISHING:

Close all remaining seams.

982



**MENS FAIRISLE
PULLOVER**

YARN: Softon and Panache

SIZES:

Sm (Med) [Lge] [X-Lge]

AMOUNT:

Col. 1: Softon - Ecru

1 (1) [1-1/4] [1-1/2] lb.

Col. 2: Softon - Turquoise

4 oz. all sizes

Col. 3: Softon - Emerald

4 oz. all sizes

Col. 4: Panache - Brown

4 oz. all sizes

Col. 5: Panache - Spring Green

4 oz. all sizes

Col. 6: Panache - Peony

4 oz. all sizes

KIT PRICE:

\$ 47.50 (47.50) [52.50] [58.00]

TENSION:

Fairisle: T 7.2

Rib: T 1/1 I

GAUGE:

Fairisle: 8 Sts., 10 Rs. = 1"

Rib: 12 Rs. = 1"

Make on Standard 24-Stitch Punch Card or Standard Electronic Machine with Ribber.

BACK:

With Col. 1 CO 172 (180) [184] [188] sts. for K1/P1 Rib. After selevedge RC 0. T 1/1 I. Knit to R 36. Transfer RB sts. to MB. Reset RC to 0. T 7.2. Knit in fairisle following color chart while incr.

on each side every 6 Rs. 1 St. 4x. At R 132 (140) [142] [146] shape armhole. On each side decr. EOR 1 St. 5x. At R 240 (250) [254] [260] mark center 64 [(68)] [72] sts. for neck opening. Remove shoulder and neckline sts. on separate WY.

FRONT:

Knit front same as back to R 210 (220) [224] [230]. Shape neckline. Place center 38 [(42)] [46] sts. in HP and all sts. to the left. Note pattern row. *On neckline edge decr. every row 1 St. 5x and EOR 1 St. 8x. At R 240 (250) [254] [260] remove shoulder sts. on WY. Reset RC to R 210 (220) [224] [230]. Reset pattern to correct row and shape remaining neckline edge from *, reversing shapings. Remove shoulder sts. on WY.

(continued next page)

(continued from previous page)

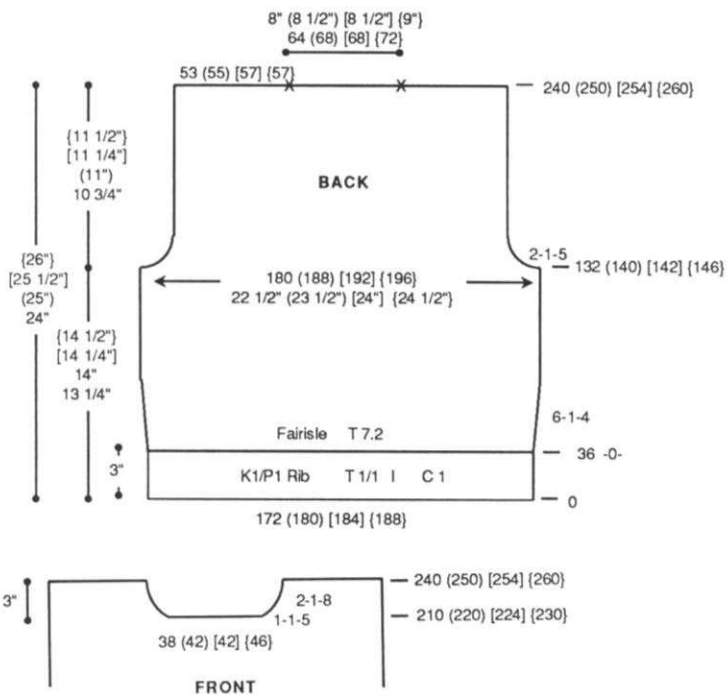

Color Chart

↑	20 R	C2
	1 R	C1
	20 R	C3
	1 R	C1
	20 R	C5
	1 R	C1
	20 R	C6
	1 R	C1
	20 R	C4
	1 R	C1
	C1	

'A' Feeder Color 'B' Feeder Color
Color # Rs Color

#983 Fairisle
24 Sts. x 42 Rows

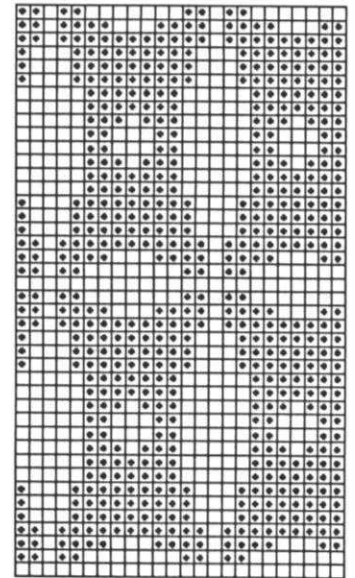

KK Magazine Disk: Tr 5; #901

SLEEVE:

Make 2 the same.
With Col. 1 CO 90 (94) [98] [102] sts. for K1/P1 Rib. After selvedge RC 0. T 1/1 I. Knit to R 36. Transfer RB sts. to MB. Reset RC to 0. T 7.2. Knit in fairisle following color chart while incr. on each side every 3 Rs. 1 St. 20x and every 4 Rs. 1 St. 21x [[[every 4 Rs. 1 St. 41x]]. At R 158 (164) [170] [174] SHR sleeve cap EOR 3 Sts. 5x. At R 168 (174) [180] [184] knit 1 row at T 10 and BOLT.

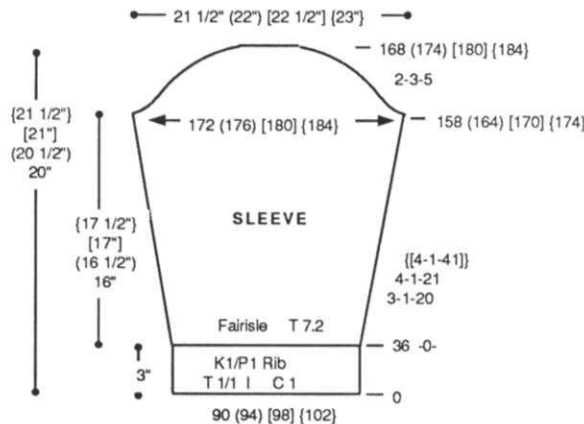

NECKBAND:

Close one shoulder. With purl side facing, rehang back front on 180 [(184)] [188] ndls. Knit 1 row at T 7.2. Transfer EOS to RB for K1/P1 Rib. RC 0. T1/1 I. Knit to R 36. Transfer RB sts. to MB. Pick up sts. from first row to form doubled band. Knit 1 row at T 10 and BOLT.

NECKBAND

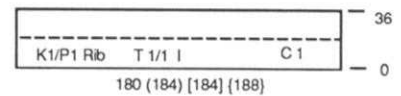

FINISHING:

Close all remaining seams.

984

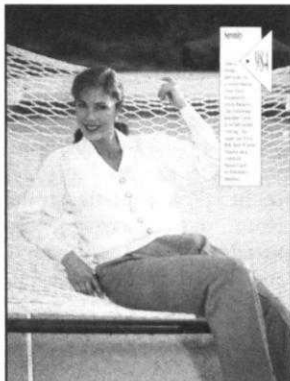

**BUTTON-FRONT
PULLOVER**

24

YARN: Venetia

SIZES: 6/8 (10/12) [14]

AMOUNT:

Col. 1: Fisherman
1 lb. all sizes

KIT PRICE: \$30.00

TENSION:

Body: T 5
FNR: T 2/2 I
Rib: -0/-0 I

GAUGE:

Body: 8.49 Sts., 12.21 Rs. = 1"

NOTIONS:

5 - 1" Buttons

Make on any Standard Machine with Ribber.

BACK:

CO 166 (174) [182] sts. for K1/P1 Rib. After selvedge RC 0. T -0/-0 I. Knit to R 60. Transfer RB sts. to MB. RC 0. T 5.

St. St. Knit to R 112 (120) [132] and shape armhole. On each side FF decr. every 4 Rs. 2 Sts. 10x. At R 212 (224) [236] shape neckline. Mark center of neckline with YM. BO center 20 sts. Place all sts. to the left in HP. *On neckline edge EOR SHR 8 Sts. 1x and 7 Sts. 1x. AT THE SAME TIME SHR shoulder EOR 6 Sts. 4x. At R 220 (232) [244] remove shoulder sts. on WY, marking side of neckline with YM. Reset RC to 212 (224) [236] and shape left neckline and shoulder from *, reversing shapings.

FRONT:

CO 166 (174) [182] sts. for K1/P1 Rib. After selvedge RC 0. T -0/-0 I. Knit to R 60. Transfer RB sts. to MB. Remove 95 (99) [103] sts. to the right on WY. RC 0. T 5. St. St. Knit to R 108

(120) [132]. Shape neckline. On right side decr. every 6 Rs. 1 St. 5x and every 8 Rs. 1 St. 8x. AT THE SAME TIME at R 112 (120) [132] shape armhole. On left side FF decr. every 4 Rs. 2 Sts. 10x. At R 212 (224) [236] SHR shoulder EOR 6 Sts. 4x. At R 220 (232) [244] remove shoulder sts. on WY. Reset RC to 0. Rehang right side of waistband on 71 (75) [79] ndls. (see chart). Knit right side same as left reversing shapings.

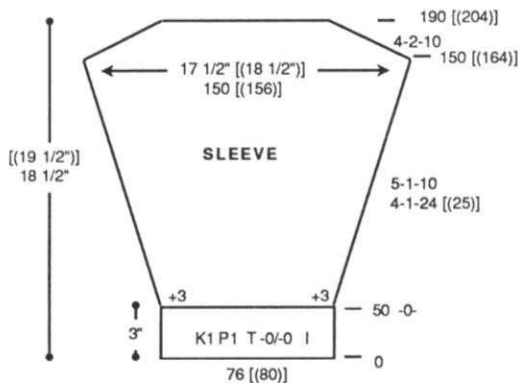

SLEEVE:

Make 2 the same.
CO 76 [(80)] sts. for K1/P1 Rib. After selvedge RC 0. T -0/-0 I. Knit to R 50. Transfer RB sts. to MB. RC 0. T 5. Incr. 3 sts. on each side. Knit in st. st. while incr. on each side every 4 Rs. 1 St. 24 [(25)] x and every 5 Rs. 1 St. 10x. At R 150 [(164)] shape sleeve cap. On each side FF decr. every 4 Rs. 2 Sts. 10x. At R 190 [(204)] knit 1 row at T 10 and BOLT.

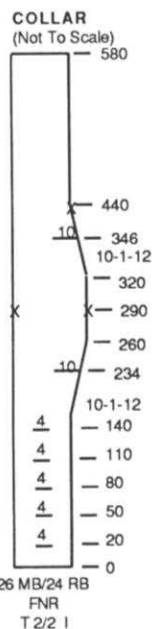

COLLAR:

CO for FNR with 26 sts. on MB and 24 sts. on RB. After selvedge RC 0. T 2/2 I. Knit to R 140 making buttonholes over 4 sts. with WY at Rs. 20, 50, 80, 110 and 140. Incr. on right side every 10 Rs. 1 St. 12x. AT THE SAME TIME at R 234 knit 1 R on 10 sts. from right side manually with WY. At R 290 place a YM on each side for center. Knit to R' 320 and start decr. every 10 Rs. 1 St. 12x. AT THE SAME TIME at R 346 knit 1 R on 10 sts. from right side manually with WY. At R 580 remove sts. on WY.

FINISHING:

Close all seams. With knit side facing, rehang 24 sts. from center of waist. Then rehang the end of collar on same ndls. Knit 1 R at loose tension manually and BOLT. Match center of collar to center of back neckline. Sew down each side of front overlapping at the bottom and joining to waistband. For finishing notched collar: Weave 10 sts. by hand.

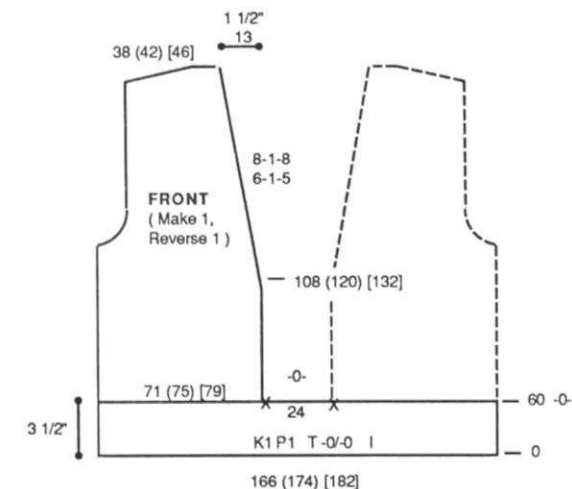
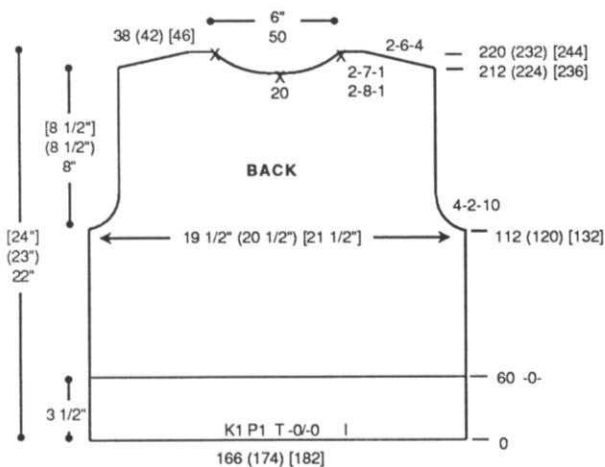

knitkng technical tips

It is important to realize that your Knitkng knitting machine is a well-built piece of precision machinery. Having said that, it is quite surprising to report that a number of repairs we receive at the Knitkng Repair Department are malfunctioning due strictly to haphazard care. So, under the category of "an ounce of prevention is worth a pound of cure," we would like to reiterate some of the "Do's" and "Don'ts" of knitting machine care:

- DO lubricate with light machine oil
- DO store your machine at room temperature
- DO change bent or broken needles immediately
- DO use your G. Carriage with yarns intended for it

- DON'T use any silicon-based lubricants.
- DON'T store in very hot, or humid environments
- DON'T let minor repairs become more serious problems
- DON'T use very thick or very "fuzzy" yarns

Finally, Knitkng stands behind all of its products with the most complete warranty protection in the industry. When requesting warranty work, though, do make sure to include a copy of your original invoice with your machine.



WOMENS TWO-PIECE DRESS with SURPLICE PULLOVER

YARN: Venetia, Glace Plus and Angora

SIZES: 6/8 (10/12) [14]

AMOUNT:
 Col. 1: Venetia - Lilac
 2 lbs. all sizes
 Col. 2: Glace Plus - Lilac
 1 cone all sizes
 Col. 3: 100% Angora - Mauve
 6 balls all sizes

KIT PRICE: \$125.00

TENSION:

Top:
 St. St.: T 5.2 Tuck: T 6
 Rib: T -0/-0 I

Skirt: St. St.: T 5.2

GAUGE:

Top:
 4.5 Sts., 6.12 Rs. = 1"

Skirt:
 7.16 Sts., 11.4 Rs. = 1"

NOTIONS:

Elastic for skirt waistband.

Make Top on Compuknit/Bulky or Punch Card Bulky with Ribber. Make Skirt on any Standard Machine

Note: Sleeve is worn on the purl side.

BACK:

With WY CO 86 (90) [96] sts. After several rows, end with 1 row Ravel Cord to the right. Change to main yarn (2 strands Col. 1 in plating finger and 1 strand Col. 2 in Feeder 'A'). RC 0. T 5.2. St. St. Knit to R 68 (70) [74]. Shape armhole. On each side BO 4 sts. then decr. EOR 1 St. 5x and every 4 Rs. 1 St. 1x. At R 100 (104) [110] remove sts. on WY. With knit side facing rehang these sts. on 60 (64) [70] ndls. decr. evenly across. RC 0. T 6.

Col. 2 in one antenna and Col. 3 in the other antenna, both in Feeder 'A'. Knit in Tuck Pattern to R 22. Knit 1 row at T 10 and BOLT.

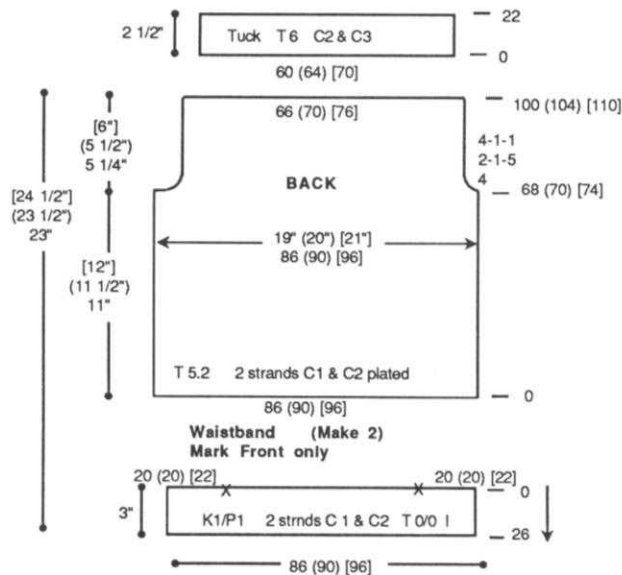

Front Overlap Diagram

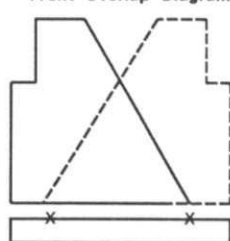

FRONT: Make 1, Reverse 1.

With WY CO 66 (70) [74] sts. After several rows, end with 1 row Ravel Cord to the right. Change to main yarn (2 strands Col. 1 in plating finger and 1 strand Col. 2 in Feeder 'A'). RC 0. T 5.2. Knit in St. St. while shaping right side. For each decr. move the 3rd st. to the 2nd st. and move 2 sts. back to fill empty ndls. Decr. every 3 Rs. 1 St. 11x, EOR 1 St. 17 (19) [21] x and every 3 Rs. 1 St. 11x. AT THE SAME TIME at R 68 (70) [74] begin armhole shaping. On the left side BO 4

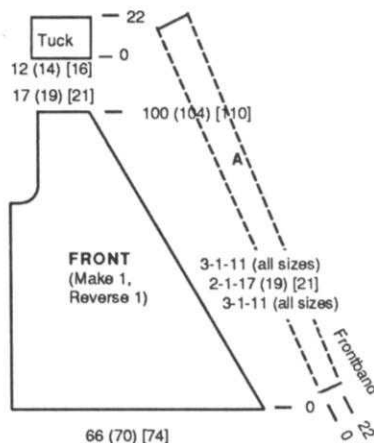

sts. then decr. EOR 1 St. 5x and every 4 Rs. 1 St. 1x. At R 100 (104) [110] remove sts. on WY. With knit side facing rehang these sts. on 12 (14) [16] ndls. decr. evenly across. Knit same as back.

FRONT BAND: Make 2.

With knit side facing, rehang front edge on 60 (62) [66] ndls. RC 0. T 6. Col. 2 in one antenna and Col. 3 in the other antenna, both in Feeder 'A'. Knit in Tuck Pattern to R 22. Knit 1 row at T 10 and BOLT.

FRONT BAND 'A'

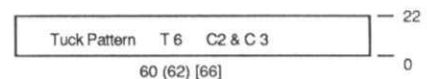

WAISTBAND:

Back: With purl side facing, rehang lower edge of back on 86 (90) [96] ndls. Transfer EOS to RB for K1/P1 Rib. RC 0. T -0/-0 I. Col. 1 (2 strands) and Col. 2. Knit 26 Rs. Knit 1 row at T 8/4. Transfer RB sts. to MB and BOLT.

Front: Bring 86 (90) [96] ndls. to WP. With purl side facing, rehang front sections on 66 (70) [74] ndls, overlapping the two front sides as shown on chart. Knit same as back.

SLEEVE: Worn on the purl side. Make 1, Reverse 1.

With main yarn (2 strands Col. 1 in 'A' feeder and 1 strand Col. 2 in plating finger) 'e' wrap CO 48 (50) [52] sts. as shown on chart. RC 0. T 5.2. St. St. Knit 11 Rs. 'e' wrap CO 20 (20) [22] sts. to the left. On left side inc. EOR 1 St. 2x, then knit 1 row.

1. At R 16 start SHR. On left side place 32 (32) [34] ndls. in HP and knit 2 rows. Continue SHR EOR 10 Sts. 3x. R 24.

2. Release HOLD button. T6. Col. 2 and Col. 3. Tuck Pattern. Knit 6 rows. R 30.

3. Change back to main yarn. T 5.2. St. St. Knit 14 rows. R 44.

4. On left side place 32 (32) [34] ndls. in HP and knit 2 rows. Continue SHR EOR 10 Sts. 3x. R 52.

5. Repeat steps 2 through 4 two more times.

6. Release HOLD button. T6. Col. 2 and Col. 3. Tuck Pattern. Knit 6 rows.

7. Change to main yarn. T 5.2. On left side place 32 (32) [34] ndls. in HP and knit 2 rows. Continue SHR EOR 10 Sts. 3x. R 122.

8. On left side dec. EOR 1 St. 2x. At R 126 manually BO 20 (20) [22] sts. to the left. Knit 11 rows. Knit 1 row at T 10 and BOLT.

SLEEVE CUFF:

With knit side facing, rehang lower edge of sleeve on 40 (40) [42] ndls. decr. evenly across. With Col. 1 (2 strands) and Col. 2 knit 1 row. Transfer EOS to RB for K1/P1 Rib. RC 0. T -0/-0 I. Knit 22 Rs. Knit 1 row at T 8/4. Transfer RB sts. to MB and BOLT.

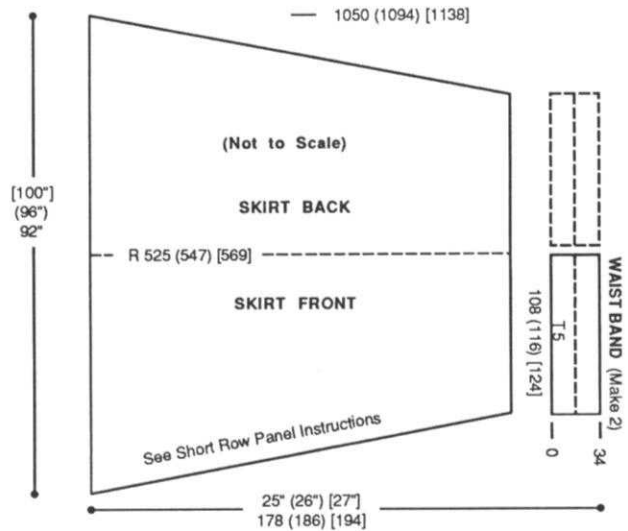

SKIRT WAISTBAND: Make 2.

With purl side facing, rehang skirt front/back on 108 (116) [124] ndls. RC 0. T 5. Col. 1. St. St. Knit to R 34. Pick up sts. from first row to form doubled band. Knit 1 row at T 10 and BOLT.

#985 Skirt Lace (Eyelet)



#985 Tuck Pattern
24 Sts. x 12 Rows

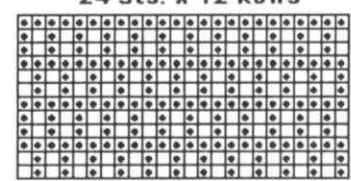

KK Magazine Disk: Tr 6; #901

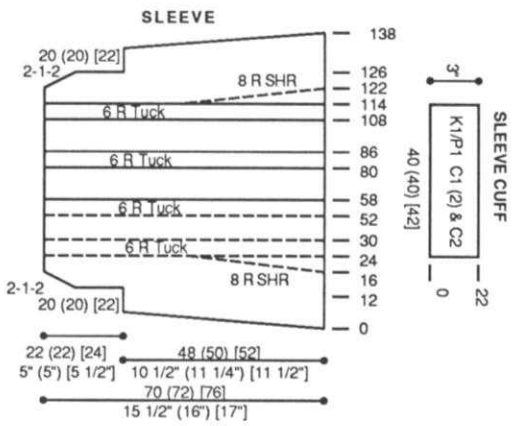

[25] x more, placing a YM on each side at R 525 (547) [569] for side seam. Then SHR on right side EOR 19 (23) [27] Sts. 1x and 20 Sts. 6x. Then reverse SHR, starting at ndl #40 to the left of center, EOR 20 Sts., ending at ndl. #80 to the right of center. Knit 7 rows over all sts. Change to Col. 2 and make 1 x 1 eyelet. Knit 2 rows. Change to Col. 1 and knit 1 row. Remove sts. on WY.

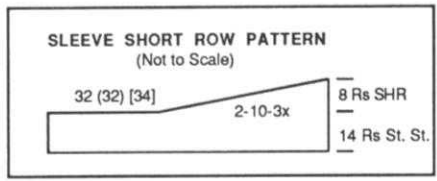

SKIRT:

With WY CO 178 (186) [194] sts. After several rows, end with 1 row Ravel Cord to the right. RC 0. T 5.2 Col. 1. St. St. *Knit 7 Rs. On right side SHR EOR 19 (23) [27] Sts. 1x and 20 Sts. 6x. Then reverse SHR, starting at ndl #40 to the left of center, EOR 20 Sts., ending at ndl. #80 to the right of center. Knit 7 rows over all sts. Change to Col. 2 and make 1 x 1 eyelet. Knit 2 rows. Change to Col. 1. Repeat from * 23 (24)

SHORT ROW INSTRUCTIONS - SKIRT

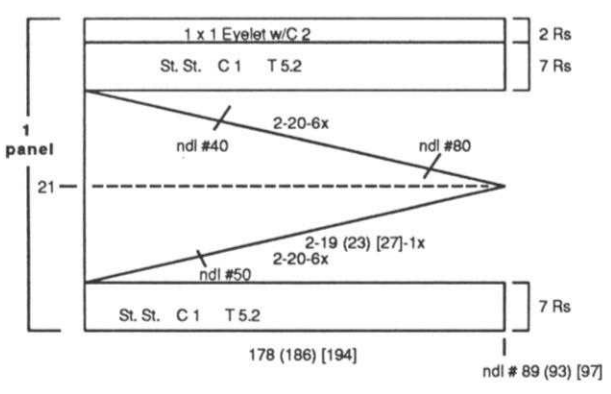

FINISHING:

Top: Close all seams. Make sleeve cap pleats 4" and attach sleeve. With Col. 2 and Col. 3, single crochet 1 time around edge of front band and neckband. Then single crochet in backwards motion, without turning garment. **Skirt:** With knit side facing rehang side seam of skirt of 178 (186) [194] ndls. Then pick up remaining side seam (with purl side facing) and rehang on same ndls. Knit 1 R at T 10 and BOLT. With Col. 2, single crochet 1 time around lower edge.

knitking
COMPUKNIT
BULKY

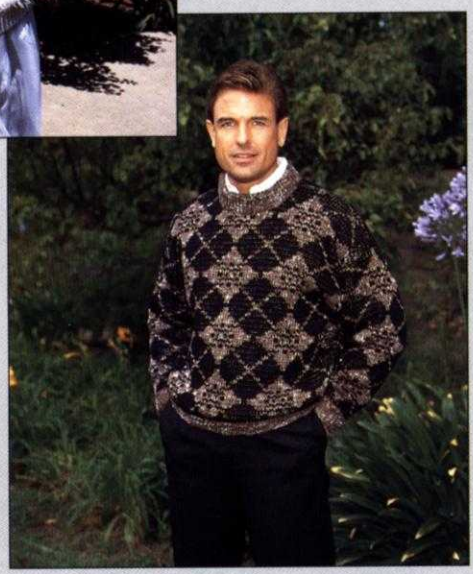
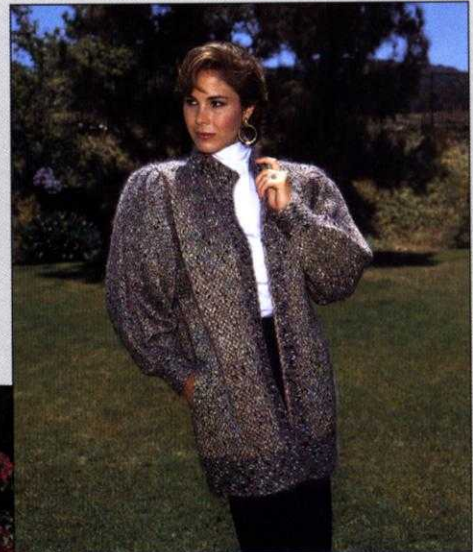

WITH THE NEW COMPUKNIT/BULKY
YOU CAN QUICKLY AND EASILY
CREATE GARMENTS LIKE THESE —
LUXURIOUS, HAND-KNIT QUALITY
GARMENTSEVERYONE WILL ADMIRE.

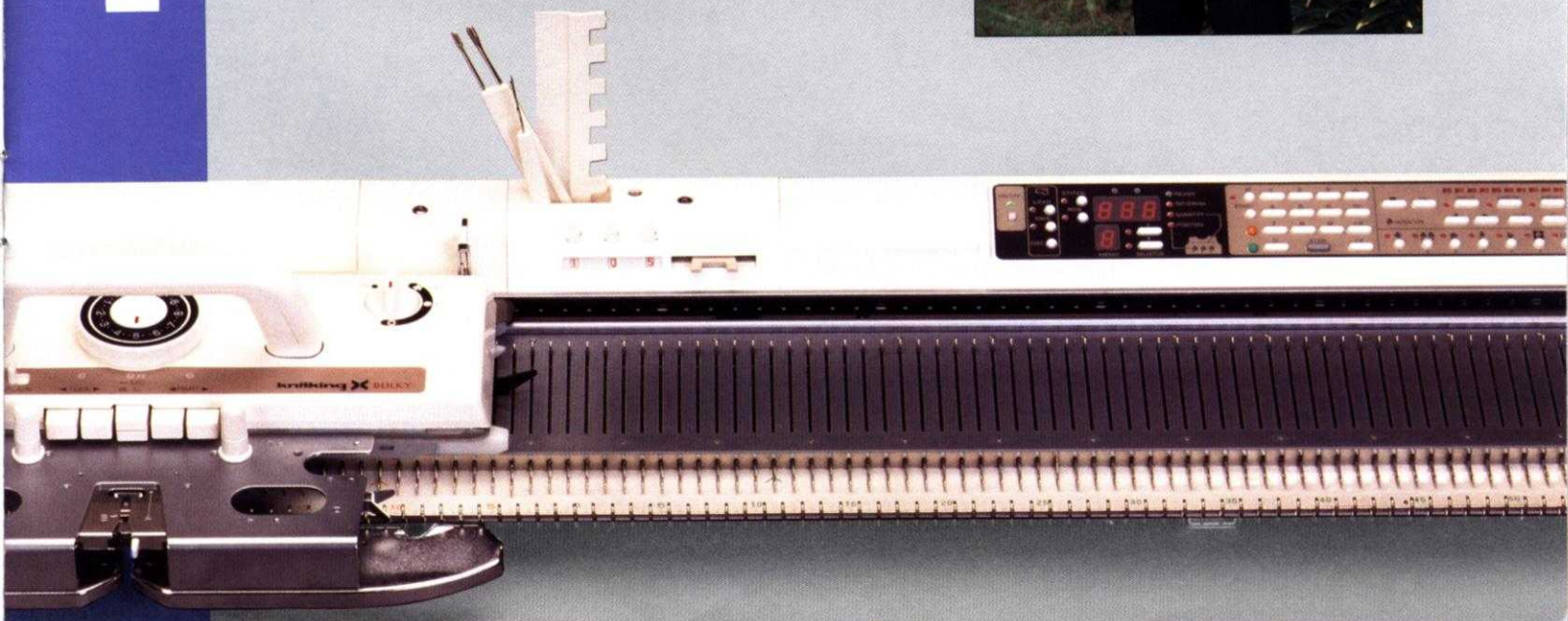

COMPUKNIT/BULKY

HAND-KNIT ELEGANCE IN A FRACTION OF THE TIME

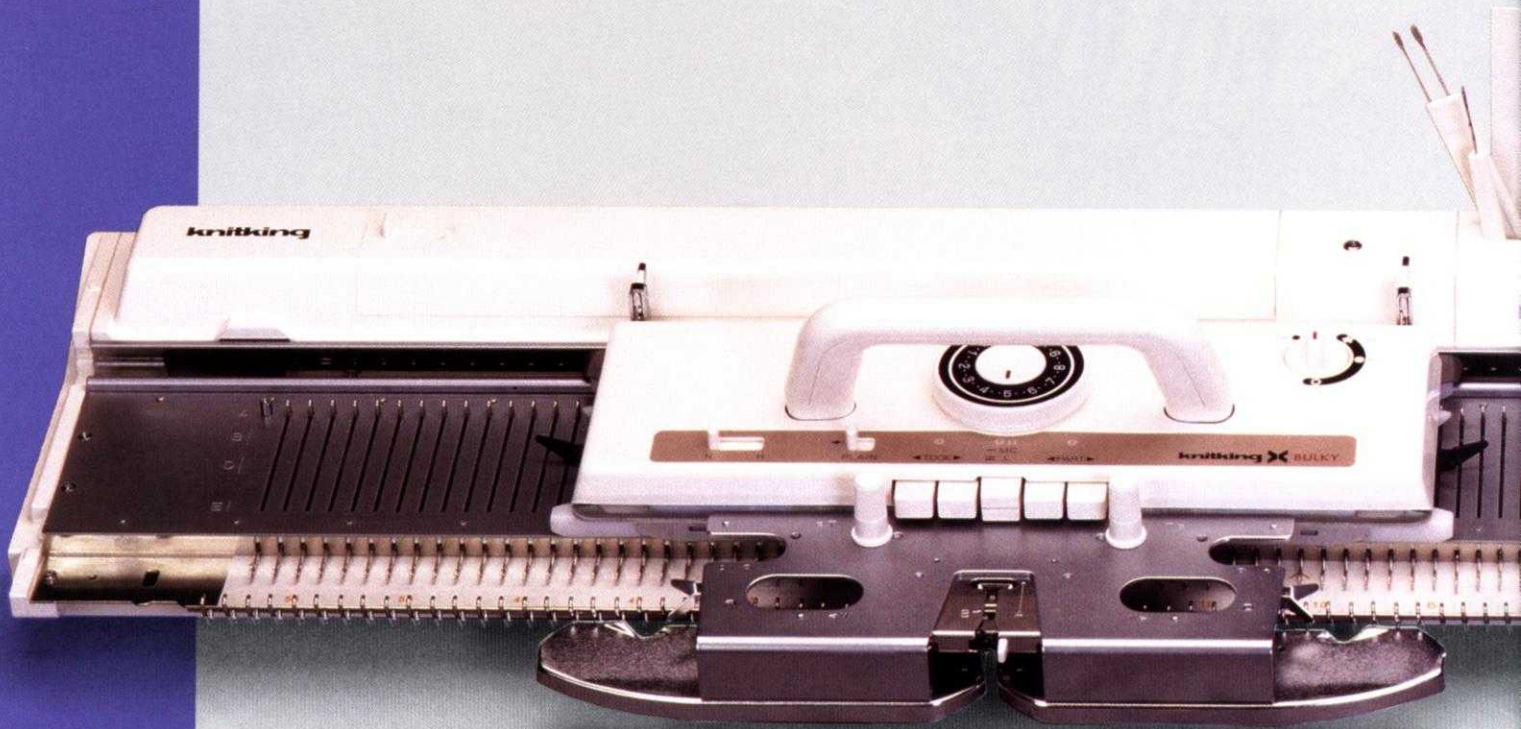

The COMPUKNIT/BULKY is shown with the Main Knitting Carriage. An optional Intarsia Knitting Carriage is also available. Complete stitch and pattern capabilities are built into the COMPUKNIT/BULKY, including Fair Isle, Tuck, Skew, and many more. Use the exclusive features of the COMPUKNIT/BULKY to achieve the elegance of hand-knits . . . in only a fraction of the time.

DESIGNER'S DREAM ACCESSORIES

PATTERN DESIGN COMPUTER



The Pattern Design Computer is an accessory specifically designed for the entire family of Compuknit knitting machines. It is a small masterpiece of computer engineering and is remarkably easy to use. You connect its cord to your color television set and draw your own original designs, in the yarn colors of your choice, on the T.V. screen. Then, simply remove the design cartridge from the unit and insert it into the slot provided on the knitting machine to transfer your designs for easy reproduction in your garment.

Over 850 designs are stored in the Pattern Design Computer's Design Cartridge including the Compuknit/Bulky's original 300. Project any of them onto your T.V. screen and modify or combine them to suit your own taste and needs. You can also isolate any section of a design for transfer into your Compuknit/Bulky.



temporary designs. The

Displays prompt the knitter with pattern number, row number, color changes and much more.

Easily place patterns or single motifs where you want them to appear on the garment.

300 patterns are already stored in the Compuknit/Bulky's memory—merely enter the pattern number of your choice from the accompanying full-color book of patterns.

Create your original designs with the push of a few buttons. Designs may be as large as 112 stitches wide and 998 rows long—up to 100 of your own designs can be stored in the pattern design memory.

Customize your pattern at the push of a button for reverse image, mirror image, double width, double length, upside down, reverse color and double bed jacquard.



available.
Thread Lace, Weaving and Plating.
action of the time.

DISK DRIVE

The Disk Drive plugs into the back of the Pattern Design Computer, and it is used for transferring your own pattern stitch designs onto a disk for recall any time you need them. Or, you can use these disks to serve as an extra copy of original patterns that you have already stored in the Compuknit/Bulky's memory. Additionally, pre-programmed disks are available, holding a large variety of beautiful con-

Disk Drive uses convenient 3.5 inch micro diskettes.



PRINTER

Attach the Printer to the Pattern Design Computer and you are able to print copies of all of your own designs, as well as those available on any pre-programmed disks. The printout even indicates color changes and filling information. The Printer comes complete with a customized "Kwik-Konnect" cable to allow it to communicate with the Pattern Design Computer.



ACCESSORIES
FOR
EVEN
GREATER
VERSATILITY

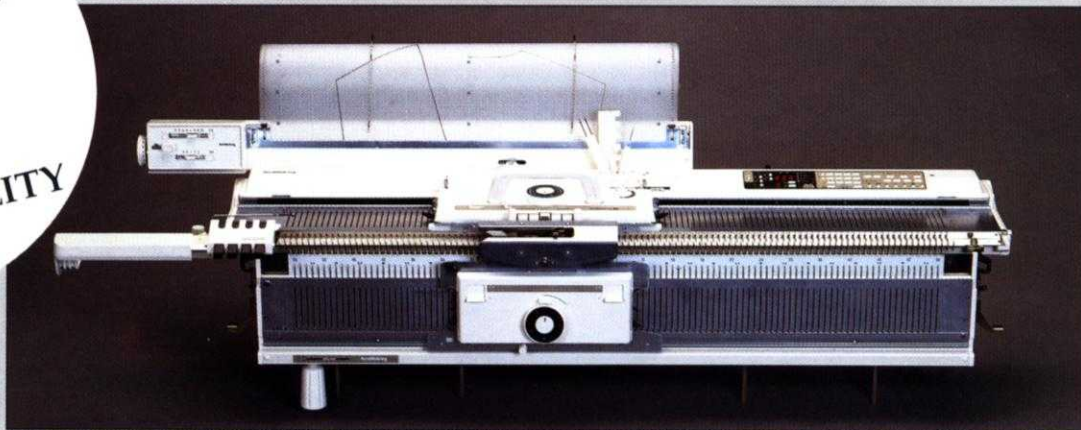

The Compuknit/Bulky is shown with the Ribbing Attachment, the Ribber Color Changer and the Knitleader (all three are optional)

RIBBING ATTACHMENT

Add the Ribbing Attachment to your Compuknit/Bulky and really experience its versatility. The Ribber allows you to knit all of the standard ribs—1x1, 2x2, 3x1—or any other combination of knit and purl you desire, plus Tubular knitting. You can knit fully ribbed dresses and sweaters, Zig-Zag racking designs, Cable Stitch designs, Herringbone designs, Tuck Stitch Rib designs, Fisherman's Rib and much more.

FOUR-COLOR CHANGER

Add the Ribber Four-Color Changer to your Knitter and Ribber combination and you will be able to knit beautiful multi-color Jacquard designs with as many as four colors of yarns in one row. It also eliminates the "floats" from the back of Fair Isle knitting. The RCC, as it is called, really helps you breeze along as you can change colors just by pushing a button. And, when the pattern calls for another color change, the yarn is returned cleanly to its holder, ready to be used again at a moment's notice.

KNITLEADER

Add a KL 16 Knitleader and you are able to create a full size chart of the garment you are knitting, which rotates row by row and tells you exactly when and where to increase and decrease stitches for accurate garment shaping.

INTARSIA CARRIAGE

The easy-to-use, optional Intarsia Carriage is to a knitter what a palette is to a painter: It extends your artistic freedom by allowing you to create any Free-Form Design without concern for the number of yarn colors. Even the hard-to-create Picture-In-Picture designs are also a snap using this simple device. A must accessory for all serious knitting enthusiasts!

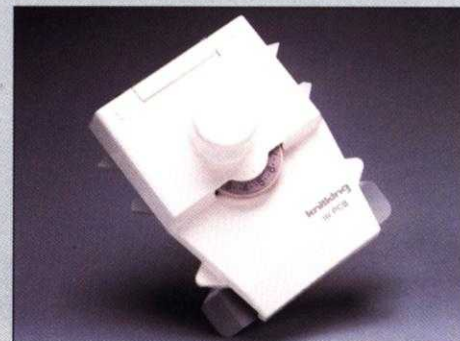

POWER DRIVE UNIT

Attach the Power Drive Unit (PDU) to the Compuknit/Bulky and it will automatically move the carriage back and forth across the knitting bed in a smooth and easy fashion, significantly reducing your knitting time. Merely set the number of rows needed and the PDU will switch itself off when the rows are completed, or if the yarn runs out, knots or breaks. The PDU will accommodate the Compuknit/Bulky by itself or with the Ribber and the Ribber Four-Color Changer without the need for additional parts.

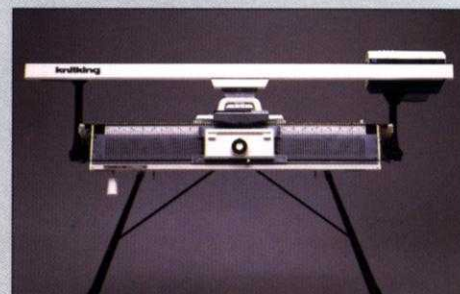

The First Name In Machine Knitting

1128 Crenshaw Blvd., Los Angeles, CA 90019 213-938-2077

987



MENS STRIPED TUCK PULLOVER

YARN: Venetia

SIZES: Small (Medium) [Large]

AMOUNT:
 Col. 1: Black - 8 oz. all sizes
 Col. 2: Cardinal - 8 oz. all sizes
 Col. 3: Jungle-8 oz. all sizes
 Col. 4: Coffee-8 oz. all sizes

KIT PRICE: \$54.00

TENSION:

Body: T 3.1/3
 Rib: T 1.2/1.2 I
 Neckband: T 0/0 I

GAUGE:
 Body: 6.75 Sts., 14.58 Rs. = 1"

Make on Standard 24-stitch Punch Card or Standard Electronic Machine with Ribber.

BACK:

With Col. 1 CO 148 (156) [162] sts. for FNR. After selvedge RC 0. T 1.2/1.2 I. Arrange ndls. as shown on chart. Knit to R 50. Reset RC to 0. T 3.1/3 I. Col. 2. Set carriage at KC (I). Knit 1 R to the left to select ndls. Depress both tuck buttons. Knit in pattern following body color chart. At R 128 (156) [180] mark each side with a YM for armhole. Continue in pattern to R 282 (310) [340]. SHR shoulders EOR 8 Sts. 5x. At R 292 (320) [350] transfer RB sts. to MB. Knit 1 R at T 10. Mark center 50 [(50)] sts. for neck opening and BOLT.

FRONT:

Knit same as back to R 240 (268) [298]. Shape neckline. BO center 20 sts. Place all sts. to the left in HP. Note pattern row. *On neckline edge decr. EOR 1 St. 15x. At R 282 (310) [340] SHR shoulders same as back. At R 292 (320) [350] transfer RB sts. to MB. Knit 1 R at T 10 and BOLT.

Reset RC to R 240 (268) [298] and shape left side from *, reversing shapings.

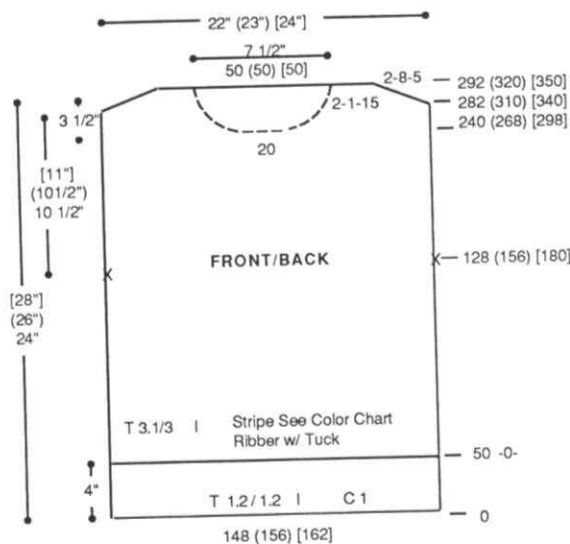

COLOR CHART - Body and Sleeve

Color	# Rows	Body	Sleeve
C1	10	Until Finished	2 x
C4	26 (28) [30]		
C1	10		
C3	26 (28) [30]	3 x	2 x
C1	10		
C2	26 (28) [30]	3 x	2 x

SLEEVE:

Make 2 the same.
 With Col. 1 CO 66 (66) [70] sts. for FNR. After selvedge RC 0. T 1.2/1.2 I. Arrange ndls. as shown on chart. Knit to R 40. Increase 2 sts. on each side. Reset RC to 0. T 3.1/3 I. Col. 2. Set carriage at KC (I). Knit 1 R to the left to select ndls. Depress both tuck buttons. Knit in pattern following sleeve color chart while shaping sleeve. On each side incr. every 6 Rs. 1 St. 26 (18) [19] x and every 7 Rs. 1 St. 10 (18) [18] x. At R 226 (234) [240] transfer RB sts. to MB. Knit 1 row at T 10 and BOLT.

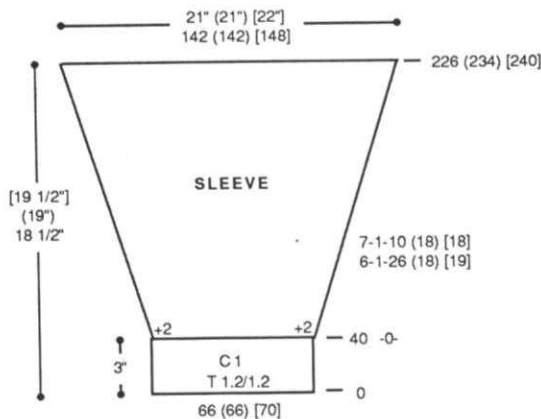

NECKBAND:

With Col. 1 CO 164 sts. for K1/P1 Rib. After selvedge RC 0. T 0/0 I. Knit to R 40. Transfer RB sts. to MB. With knit side facing, rehang neckline on these needles placing front/back as shown on chart. Knit 1 R across at T 10 and BOLT.

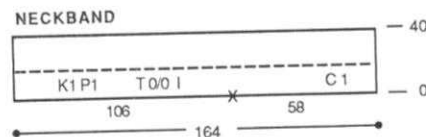

#987 Needle Arrangement Tuck and Rib Pattern

MB

RB



#987 Tuck Pattern

24 Sts. x 36 (38) [40] Rows

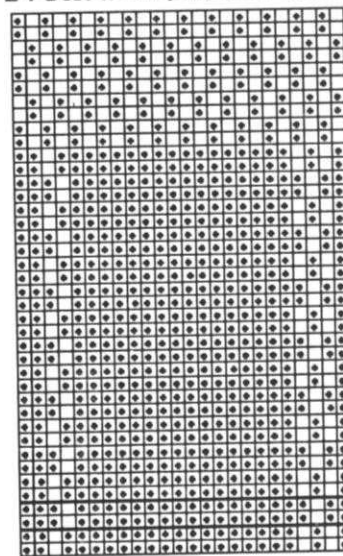

—(Sm)
 —(Med)
 —(Lrge)

KK Magazine Disk: Tr 7;

#901-[Lrge]; #902-(Med); #903-Sm

FINISHING:

Close all seams. Fold neckband to inside and whip stitch in place to form doubled band.

THE NEW DESIGNAKNIT COMPUTER-AIDED DESIGN PROGRAM

The program that all knitters, machine as well as hand, have only been able to dream about is now available. DesignaKnit is an IBM Compatible State of the Art Program which includes many facets of knitting, not just the designing. It is a complete software package, made up of two basic programs, Garment Shaping and Color Patterning. They can be used separately or easily integrated. After selecting or creating your garment shape and color pattern, you can superimpose one over the other right on the computer screen so you can see precisely what your garment will look like. Then you can move the stitch pattern around to improve the position. Sound intriguing, well there is more.

Within DesignaKnit, you have the option to print your work in a wide variety of ways. It also includes a color separation program for double jacquard knitting at no extra charge. And you can even transfer your stitch patterns back and forth between the computer and certain Knitking or Brother knitting machines or pattern design computer.

Now that I have your interest, let's delve a little deeper into the guts of the program.

GARMENT SHAPING

There are a number of standard garment shapes at your beck and call. You can vary any of them with your choice of body shapes, sleeve shapes, rib specifications and neckline variations. Once a garment shape is selected and varied according to your preference, you can customize the fit to your measurements.

At this point, a line drawing of your garment is shown on the screen, and you are given the option of altering specific styling features of the garment. For example, you can change neck width, neck depth, shoulder drop, rib lengths, the sleeve angle, the blousing, and more. Each change is made with just the touch of the keyboard, and the picture on the screen is automatically redrawn so that you see the effect of the change immediately.

There is also a Professional Version of DesignaKnit available which gives you the ability to create your own completely-original garment shape from scratch or alter one from the built-in Standard Shapes, stitch by stitch. This feature gives you the

freedom to generate your own design with a minimum of effort.

COLOR PATTERNS

This portion of the program is like having your own personal Knitting Paint Program. It speaks knitting language (Stitches and Rows) verses engineering lingo (X and Y axis) that the traditional paint programs use. You have thousands of colors available to you, 50 of which can be used in one pattern. If you choose to exchange one color for another in any portion of your pattern, it is merely a matter of making a selection from your Windows-like menu.

The design that you are about to color can be an original drawing or pattern (made with the "mouse" or arrow keys). You also have the option of using designs created by other means, such as from a scanner, a clip art program or the built-in patterns from the Compuknit KC (PPD).

Once you get the image to your liking, you still have other options. You can repeat the motif or pattern throughout the garment, you can edit it — stitch by stitch — you can delete or insert stitches or rows, you can mirror image it, rotate it, and much more. There is even a special feature which allows you to set a limit on the maximum number of stitches in a float. Floats that are over that number will be highlighted, making it easy to adjust your pattern to eliminate the longer floats.

A specific gauge can be set at any time whether you are in the Garment Shaping or Color Pattern section of DesignaKnit. The gauge can readily be changed at any time, thus converting the pattern to the new gauge.

PRINTING

The print options are Extensive. You have a choice of printing shape only, color pattern only or superimpose the two. These printouts can be in a variety of forms or combinations of forms, such as knitting instructions, shaping chart, fairisle or intarsia charts, templates for the knitleader or knitradar, miniature outline for pinning and blocking, and to-scale punch card and mylar templates, just to name a few.

LINKING TO YOUR KNITTING MACHINE

It's a cinch to transfer your pattern to your

Knitknit Compuknit III or IV (or Brother 930 or 940) knitting machine (using an optional cable); or, alternatively, to your Knitknit KC Pattern Design Computer (or Brother PPD) (using another cable) for subsequent transfer to your Knitknit Compuknit Bulky, III or IV (or Brother 270, 930 or 940). Patterns from these devices can also be transferred into DesignaKnit. This time saving feature allows you to spend more time on the actual knitting.

COMPLETE USER SUPPORT

Whether you are in the Garment Shaping or Color Pattern section, the flow of this program makes it extremely easy to use. If you are completely new to computers or have very limited knowledge of its workings, a wonderful interactive tutorial program is included (in addition to the instruction manual) to get you acquainted rapidly with DesignaKnit so you can use it to its fullest potential. And once you are using the program itself, there are many on-screen help messages available to assist you.

Along with the purchase of DesignaKnit, Knitknit provides you with a special DesignaKnit Technical Support Hot Line. The support team are knitters

first who are ready to assist you with your questions about the program, if you have any.

HOW TO TRY OR BUY

The Standard and Professional versions of DesignaKnit are available from participating dealers of all brands of knitting machines across the country. Or you can inquire by calling Knitknit toll-free at 1-800-962-6446. The introductory sale price of the Standard version is \$249.95 (or \$329.95 with a cable) and the Professional version is \$329.95 (or \$399.95 with a cable). A demonstration disk is a great way to sample the program before buying, and only costs \$10.

DesignaKnit is a dream come true for all machine knitters. It's a must for anyone who has an electronic knitting machine and an IBM compatible computer, or for that matter anyone who has a punch card machine or hand knits. I hope that you enjoy yours as much as I have mine.

Jill Stern is a renowned author, designer and machine knitting instructor. Her extensive titles include Design Knitting the Bulky Way, G—I Did It, Metamorphosis, Fashionably Dressed, and her soon-to-be-released G—I Did It Again, Men in Design, Buttons and Bands, Red White and You, and A Black and White Story.

The Ultimate Knitwear Design Program Is Here!

Turn Your Computer into a Design Studio . . .
with Knitknit's DESIGNAKNIT

What Can You Do with DESIGNAKNIT?

- Design your own automatically-sized garments by choosing the basic shape, sleeve and neckline from the extensive built-in offerings, then easily alter garment features on the computer screen.
- Create and modify stitch patterns for fairisle, intarsia, tuck, skip, weaving, lace and jacquard—and make your color decisions from thousands of choices.
- Import computerized graphic files—original or scanned—for your design.
- Superimpose your stitch pattern anywhere on your garment shape—you can see the finished product on your screen or print it out.
- Print scaled drawings, instructions, stitch patterns, punch card and mylar templates, and much more.
- *Professional Version:* Includes above + ability to create your own shapes, and override stitch shaping or color layout stitch by stitch.
- *Optional interface allows transferring patterns into your Compuknit IV (KH940) or Comp/Bulky (KH270).*

EB® Unmatched Design Features
EB® Technical Assistance Hotline
EB® Low Introductory Prices

What Do You Get With DESIGNAKNIT?

- PC-computer compatibility (with EGA or VGA screen) • 3.5 or 5.25 disk.
- Nationwide support through Knitknit's *DesignaKnit Technical Assistance Hotline* to compliment the built-in Tutorial program and Instruction Manual.

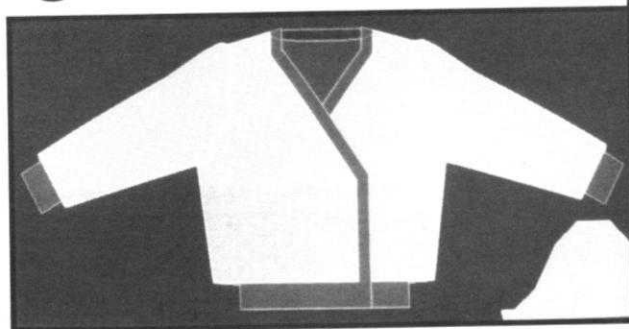

Special Introductory Price: \$249.95
(Professional Version: \$329.95)



Contact your local Dealer to order, or to request a Demo Disk (\$10.00). If there is no Dealer near you, contact:



Call: (800) 962-6446, ext. 1

Dealer Inquiries Welcome

988



TWO-PIECE DRESS with FAIRISLE PULLOVER

YARN: Venetia

SIZES:

6/8 (10/12) [14]

AMOUNT:

Col. 1: Dark Champagne
1-1/2 (1-1/2) [2] lbs.

Col. 2: Fisherman

1 lb. all sizes

KIT PRICE:

\$74.00 (\$74.00) [\$88.00]

TENSION:

Fairisle: T 5

Rib: T 0/0 I

GAUGE:

Fairisle: 8.7 Sts., 10.9 Rs. = 1"

NOTIONS:

Elastic for skirt waistband.

Make on Compuknit III/IV with Ribber.

Note: Use KCC Variation Button to Reverse Color for 1 Sleeve and Back.

BACK: Reverse Color.

With Col. 1 CO 174 (184) [192] sts. for K1/P1 Rib. After selvedge RC 0. T 0/0 I. Knit to R 50. Transfer RB sts. to MB. RC 0. T 5. Col. 1 and Col. 2. Knit in fairisle. At R 122 (132) [136] shape armhole. On each side BO 6 sts. then decr. EOR 1 St. 4x. At R 220 (230) [240] SHR shoulders EOR 3 Sts. 4x. At R 230 (240) [250] mark center 76 sts. with YM for neckline. Mark center of neckline with YM. Remove neckline and shoulder sts. on separate WY.

FRONT: Do not Reverse Color.

Knit front same as back to R 180 (190) [200]. Shape neckline. Place center 26 sts. in HP and all sts. to the left in HP. Note pattern row. *On neckline edge SHR every row 1 St. 10x and EOR 1 St. 15x. At R 220 (230) [240] SHR shoulder same as back. At R 230 (240) [250] remove shoulder sts. on WY. Reset RC to R 180 (190) [200]. Reset pattern to correct row. Shape left side from *, reversing shapings. Mark center of neckline with YM. Remove shoulder and neckline sts. on separate WY.

SLEEVE: Reverse Color on 1 Sleeve.

With WY CO 126 (130) [134] sts. After several rows end with 1 row Ravel Cord to the right. RC 0. T 5. Col. 1 and Col. 2. Knit in fairisle while shaping sleeve by incr. on each side every 6 Rs. 1 St. 18x and every 7 Rs. 1 St. 6x (every 7 Rs. 1 St. 22x) [every 7 Rs. 1 St. 24x]. At R 164 (170) [176] SHR sleeve cap on each side EOR 15 Sts. 4x. At R 174 (180) [186] knit 1 row at T 10 and BOLT.

SLEEVE CUFF:

With purl side facing rehang lower edge of sleeve on 90 (90) [94] ndls. decr. evenly across. Col. 1. Knit 1 R. Transfer EOS to RB for K1/P1 Rib. RC 0. T -0/-0 I. Knit 42 Rs., knitting last row at T 8/4 and BOLT.

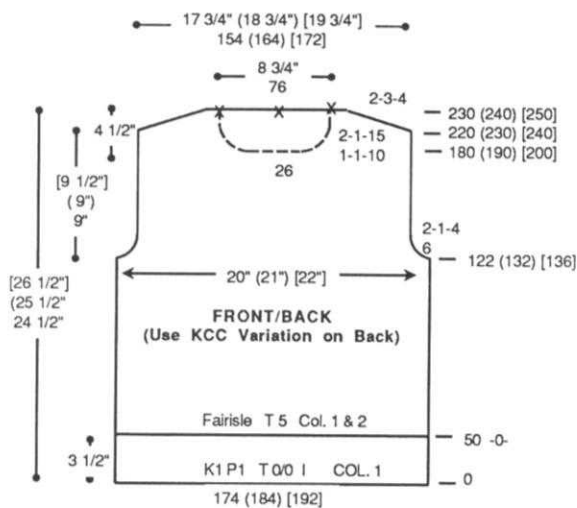

#988 Fairisle 197 Sts. x 54 Rows

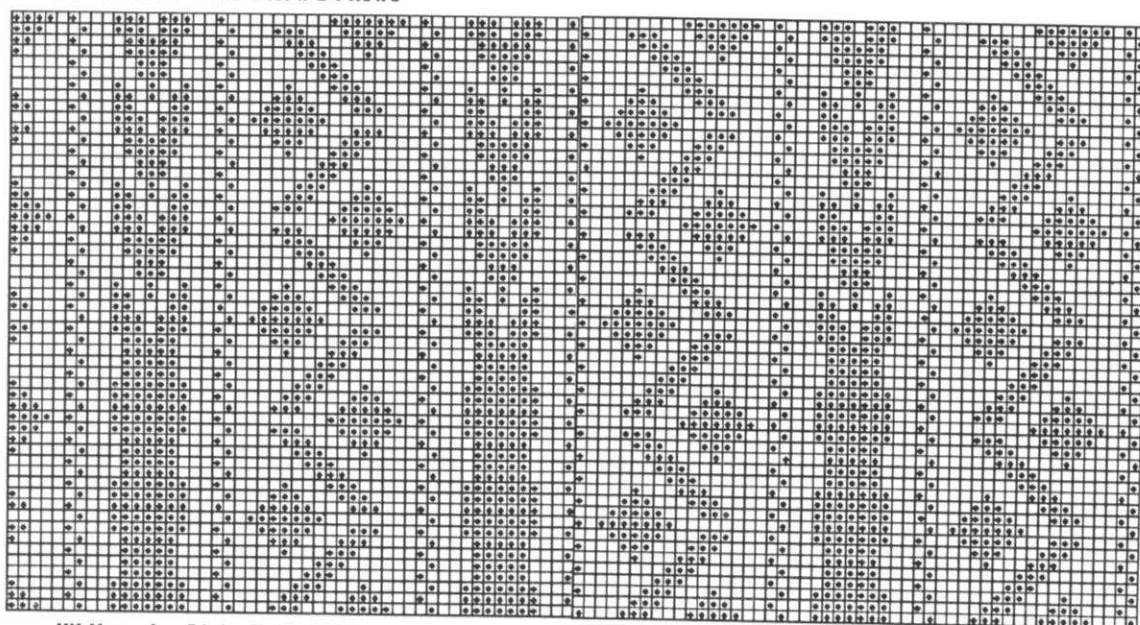

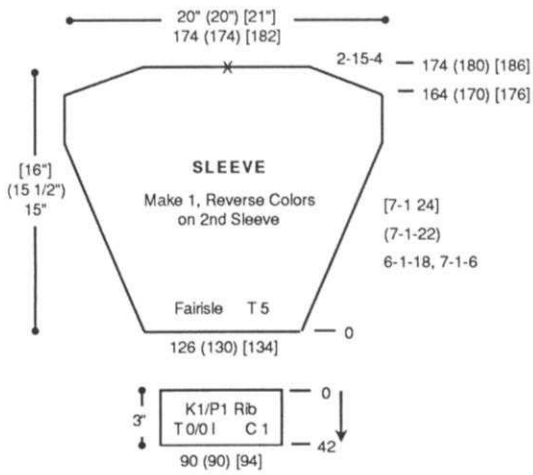

BACK NECKBAND:

With Col. 1 CO 76 sts. for K1/P1 Rib. After selvedge RC 0. T 1.1/1.1 I. Knit to R 14 and change to T 0.1/0.1 I. Knit to R 36 and change to T 1.1/1.1 I. Knit to R 52. Transfer RB sts. to MB. With purl side facing rehang back neckline on these ndls. Knit 1 row at T 10 and BOLT.

BACK NECKBAND

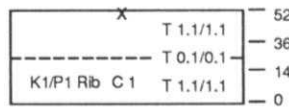

76

FRONT NECKBAND:

With Col. 1 CO 190 sts. for K1/P1 Rib. After selvedge RC 0. T 1.1/1.1 I. Knit to R 14 and change to T 0.1/0.1 I. Knit to R 36 and change to T 1.1/1.1 I. Knit to R 52. Transfer RB sts. to MB. With purl side facing rehang front neckline on these ndls. Knit 1 row at T 10 and BOLT.

SKIRT FRONT/BACK: Make 2 the same.

With WY CO 172 (180) [190] sts. After several rows end with 1 row Ravel Cord to the right. RC 0. T 4. Col. 1. St. St. Knit to R 20. Pick up sts. from first row to form doubled hem. Reset RC to 10. T 5. St. St. Knit shaping lower edge by SHR shaping on each side EOR 18 Sts. 3x. At R 244 (256) [268] mark each side with YM for aid in seaming. Begin decr. on each side every 10 Rs. 1 St. 5x. At R 294 (306) [318] SHR on each side EOR 10 Sts. 3x. At R 300 (312) [324] remove sts. on WY.

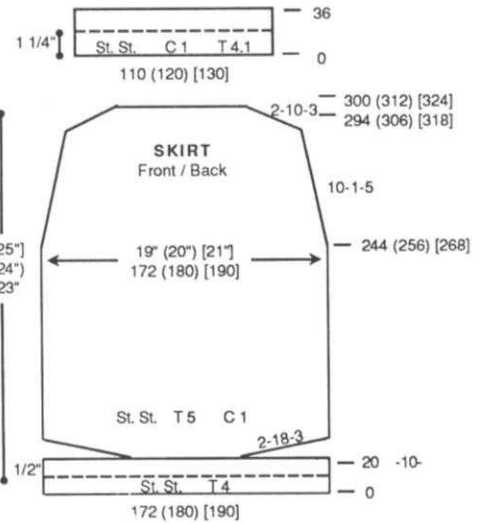

WAISTBAND:

With purl side facing rehang upper edge of skirt front/back on 110 (120) [130] ndls. decr. evenly across. RC 0. T 4.1. Knit in St. St. to R 36. Pick up sts. from first row to form doubled band. Knit 1 row at T 10 and BOLT.

FINISHING:

Attach collar matching YM's. Sew neckband together with half of seam to the inside and half of seam to the outside for roll-over collar. Close shoulder seams. Close all remaining seams.

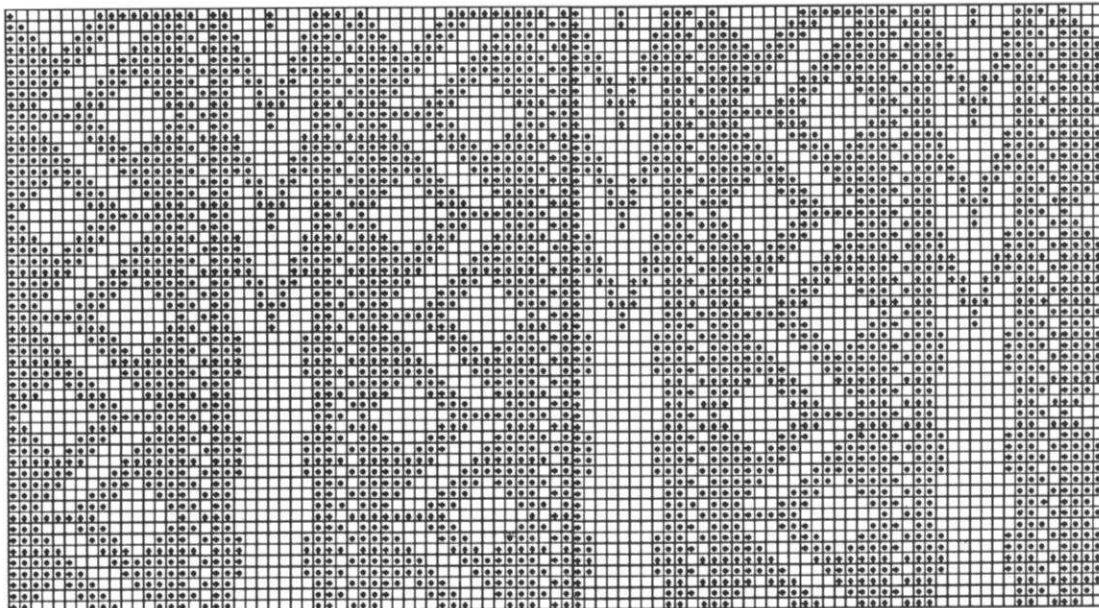
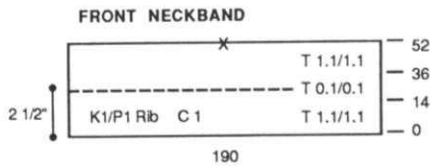

989



**BULKY JACKET with
GARTER BAR TURNS**

YARN:

Acrylite, Softon and Pebble

SIZES:

Small (Medium) [Large]

AMOUNT:

Col. 1: Acrylite-Vanilla

1-1/4 lb. all sizes

Col. 2: Softon-Ecru

1-1/4 lb. all sizes

Col. 3: Grey/Taupe Pebble

1-1/4 lb. all sizes

KIT PRICE: \$68.00

TENSION:

Body: T 5

Rib: T 1/1 I

GAUGE:

Body: 4 Sts., 6 Rs. = 1"

Rib: 7 Rs. = 1"

NOTIONS:

6 - 3/4" Buttons

Make on any Bulky Machine with Ribber. Bulky Garter Bar aids in easy knitting.

Note: Use Col. 1 and Col. 2 together throughout.

Pebble stripes are not included in measurements.

Garment is knit sideways.

Garment is worn with purl side of Pebble yarn facing.

Pattern Instructions:

*Knit 10 rows with Col. 1 and Col. 2. Reverse work with Garter Bar. Knit 10 rows with Col. 3. Reverse work with Garter Bar. Repeat from * to end.

BACK:

With WY CO 80 sts. for all sizes. After several rows, end with 1 row Ravel Cord to the left. Place a YM for sleeve as shown on chart. T 5. Work in pattern marking neck opening on the right side at R 100 and R190. At R 290 mark

center with YM for sleeve and remove sts. on WY.

BACK (Knitted Sideways)

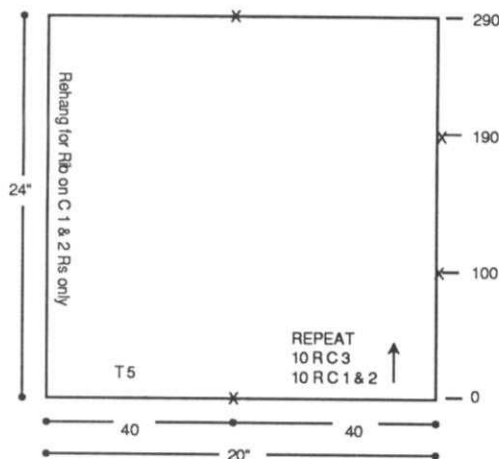

BACK BODY RIB:

Rehang Col. 1 and Col. 2 stripes on 86 (92) [100] ndls. With Col. 1 and Col. 2 knit 1 row at T 5. Transfer EOS to RB for K1/P1 Rib. RC 0. T 1/1 I. Knit to R 28, knitting last row at T 5/6. Transfer RB sts. to MB and BOLT.

BACK BODY RIB (Make 1)

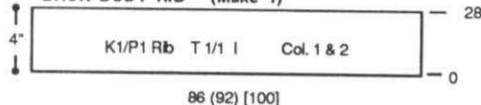

FRONT: Make 2.

With WY CO 80 sts. for all sizes. After several rows, end with 1 row Ravel Cord to the left. Place a YM for sleeve as shown on chart. T 5. Work in pattern to R 100. Remove sts. on WY.

FRONT (Make 2 Knitted Sideways)

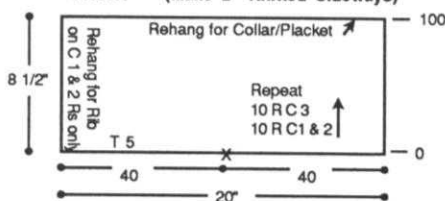

FRONT BODY RIB: Make 2.

Rehang Col. 1 and Col. 2 stripes on 28 (32) [38] ndls. With Col. 1 and Col. 2 knit 1 row at T 5. Transfer EOS to RB for K1/P1 Rib. RC 0. T 1/1 I. Knit to R 28, knitting last row at T 5/6. Transfer RB sts. to MB and BOLT.

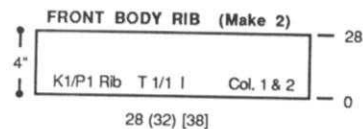

SLEEVE: Make 2.

With WY CO 60 sts. for all sizes. After several rows, end with 1 row Ravel Cord to the left. T 5. Work in pattern to R 100. Mark right side with a YM for center of sleeve. Continue in pattern to R 200. Remove sts. on WY.

SLEEVE (Make 2 Knitted Sideways)

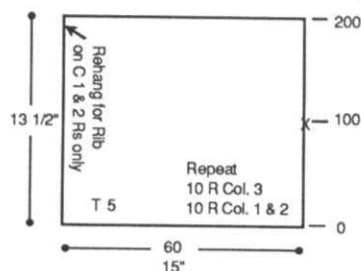

SLEEVE RIB: Make 2.

Rehang Col. 1 and Col. 2 stripes (from sleeve edge) on 30 (36) [40] ndls. With Col. 1 and Col. 2 knit 1 row at T 5. Transfer EOS to RB for K1/P1 Rib. RC 0. T 1/1 I. Knit to R 28, knitting last row at T 5/6. Transfer RB sts. to MB and BOLT.

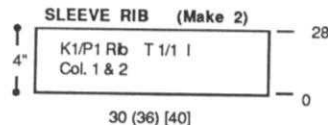

FRONT PLACKET AND COLLAR SECTION:

Make 1 with buttonholes, 1 without.

With Col. 1 and Col. 2 CO 110 Sts. for K1/P1 Rib. After selvedge, T 1/1 I. RC 0. Knit to R 54 (60) [64] making buttonholes at R 16 (18) [20] and R 38 (40) [42] over 3 sts. with WY as shown on chart. Knit 1 row at T 5/6. Transfer RB sts. to MB and BOLT.

FRONT PLACKET AND COLLAR
(Make 1 w/ Buttonholes, 1 w/o)

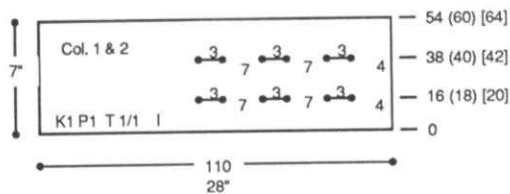

BACK CENTER COLLAR SECTION:

With Col. 1 and Col. 2 CO 40 Sts. for K1/P1 Rib. After selvedge,

T 1/1 I. Knit to R 54 (60) [64]. Knit 1 R at T 5/6. Transfer RB sts. to MB and BOLT.

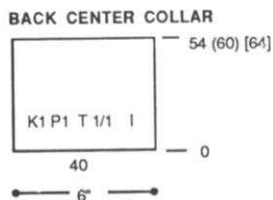

FINISHING:

Join shoulder seams. Join the three sections of front placket and collar center and attach to jacket. With purl side of C3 facing, hang front/back and with knit side of C3 facing on sleeve edge, rehang on same ndls. to attach sleeves. Close all remaining seams. Finish buttonholes with sewing needle.

990



GIRLS RAGLAN PULLOVER

YARN: Mirage

SIZES:

8 (10) [12] [14]

AMOUNT:

- Col. 1: Raspberry - 1 lb.
- Col. 2: Turquoise - 4 oz.
- Col. 3: Jade - 2 oz.
- Col. 4: White - 2 oz.
- Col. 5: Navy - 2 oz.

KIT PRICE: \$22.00

TENSION:

Body: T 4.1

Rib: T 0/0 I

GAUGE:

Body: 4 Sts., 6.1 Rs. = 1"

Rib: 7 Rs. = 1"

Make on Compuknit/Bulky or Punch Card Bulky with Ribber.

Note: All incr. and decr. are full fashion on the third needle from edge.

Color Pattern Instructions:

Knitted manually:

1. Carr in H position.
2. Select ndls manually for color pattern (see chart). Knit these selected ndls manually, then place in HP.
3. Knit 1 R with Col. 1. Repeat Steps 2 and 3.

BACK/FRONT:

With WY CO 68 (72) [76] [80] sts. After several rows, end with 1 row Ravel Cord to the right. RC 0. T 4.1. Col. 1. Follow Color Chart and Motif Placement. Knit 4 Rs. Shape sides by FF incr. on each side EOR 1 St. 4x. At R 62 (64) [68] [72] begin raglan shaping. On each side BO 2 Sts., then FF decr. EOR 1 St. 21 (23) [25] [27] x. At R 106 (116) [124] [132] remove sts. on WY.

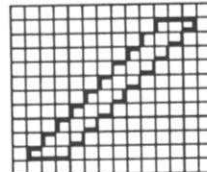
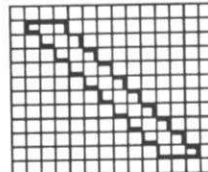

WAISTBAND:

With purl side facing, rehang lower edge of back /front on 64 (68) [72] [80] ndls. With Col. 1 knit 1 row at T 4.1. Transfer EOS to RB for K1/P1 Rib. T 0/0 I. Knit 16 Rs, knitting last row at T 8/4 and BOLT.

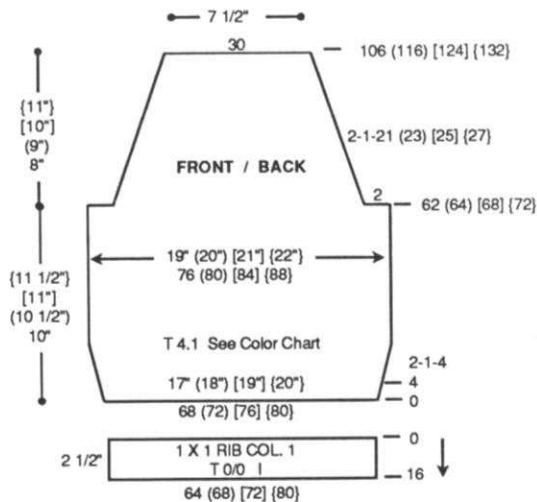

#990 Front/Back Color Chart

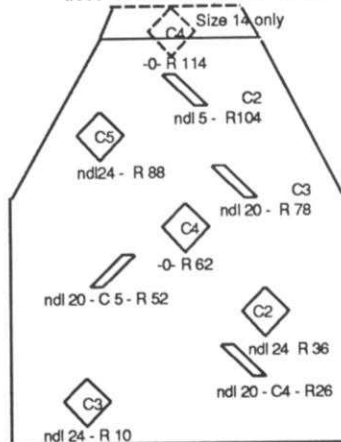

 Punch Card Patterns - Use In Order
 OR Manual Knitting (See stitch detail chart)

#990 Fairisle Motif
24 Sts. x 60 Rows

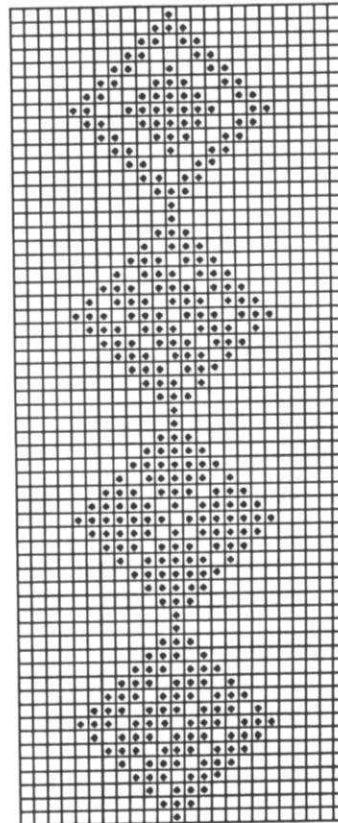

KK Magazine Disk: Tr 9; #901

(continued next page)

(continued from previous page)

SLEEVE:

Make 2 the same.

With WY CO 28 (32) [36] [40] sts. After several rows, end with 1 row Ravel Cord to the right. RC 0. T 4.1. At R 4 knit in single motif fairisle following color chart and shape sleeve on both sides by FF incr. EOR 1 St. 12x. At R 38 (40) [44] [48] FF incr. on both sides every 5 Rs. 1 St. 4x. At R 62 (64) [68] [72] begin raglan shaping. On each side BO 2 Sts., then FF decr. EOR 1 St. 21 (23) [25] [27] x. At R 106 (116) [124] [132] remove sts. on WY.

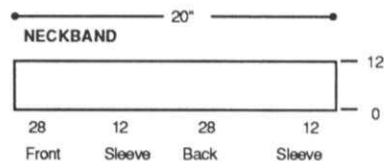
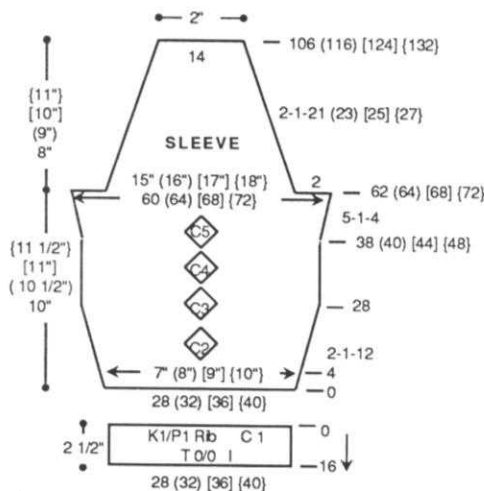

NECKBAND:

With purl side facing, rehang back, sleeve, front, sleeve on 80 ndls. following chart. With Col. 2 knit 1 row at T 4.1. Transfer EOS to RB for K1/P1 Rib. T 0/0 I. Knit 12 Rs, knitting last row at T 8/4 and BOLT.

SLEEVE CUFF: Make 2.

With purl side facing, rehang lower edge of sleeve on 28 (32) [36] [40] ndls. With Col. 1 knit

1 row at T 4.1. Transfer EOS to RB for K1/P1 Rib. T 0/0 I. Knit 16 Rs, knitting last row at T 8/4 and BOLT.

FINISHING:

Close all seams.

Put Your Creativity into the Spotlight: Compuknit KC

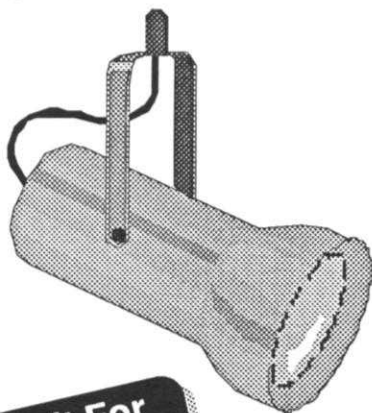

Buy It For
As Little As
\$20/Mo.

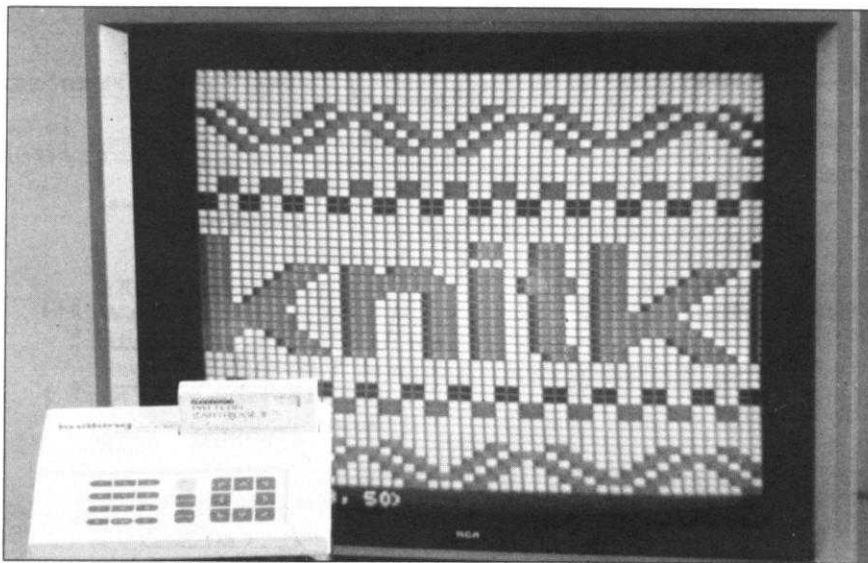

By turning your color television set into a theater of knitwear designs, the **Compuknit KC Pattern Design Computer** allows you to make your own creativity the star, while at the same time make fine-tuning adjustments in your beautiful designs with the push of a button. Then, you can experiment with different yarn color combinations *right on your T.V. screen* and in seconds start knitting your new pattern automatically!

Next to Knitking's exclusive Garter Carriage, the **Compuknit KC** is easily the most popular of accessories. Complete with its "Omni Cartridge," the **Compuknit KC** works with all of Knitking's Compuknit knitters. And, using the **Compuknit KC** in conjunction with Knitking's brand new *DesignaKnit* computer-aided software design package allows *DesignaKnit* creations to be transferred into the Compuknit/Bulky.

With a Special Introductory Sale Price of \$489.95—a savings of \$100.00!—isn't it time that you finally put your creative talents into the spotlight with the Compuknit KC?





BOYS RAGLAN CARDIGAN

YARN: Mirage

SIZES:

6 (8) [10] [12]

AMOUNT:

Col. 1: White - 1 lb.

Col. 2: Turquoise - 4 oz.

Col. 3: Jade - 2 oz.

Col. 4: Raspberry - 2 oz.

Col. 5: Navy - 2 oz.

KIT PRICE: \$22.00

TENSION:

Body: T 4.1

Rib: T 0/0 I

GAUGE:

Body: 4 Sts., 6.1 Rs. = 1"

Rib: 7 Rs. = 1"

NOTIONS:

3 - 1" Buttons

Make on Compuknit/Bulky or
Punch Card Bulky with Ribber.

Note: All incr. and decr. are full
fashion on the third needle from
edge.

Color Pattern Instructions:

Knitted manually:

1. Carr in H position.

2. Select ndls manually
for color pattern (see
chart). Knit these selected
ndls manually, then place
in HP.

3. Knit 1 R with Col. 1.

Repeat Steps 2 and 3.

BACK:

With WY CO 64 (68) [72] [76]
sts. After several rows, end with 1
row Ravel Cord to the right.
RC 0. T 4.1. Col. 1. Follow
Color Chart and Motif Placement.
Knit 4 Rs. Shape sides by FF
incr. on each side EOR 1 St. 4x.
At R 38 place a YM on each side
for pocket. At R 58 (62) [64]
[68] begin raglan shaping. On
each side BO 2 Sts., then FFdecr.
EOR 1 St. 22 (24) [26] [28] x. At

R 102 (110) [120] [128] knit 1
row at T 10 and BOLT.

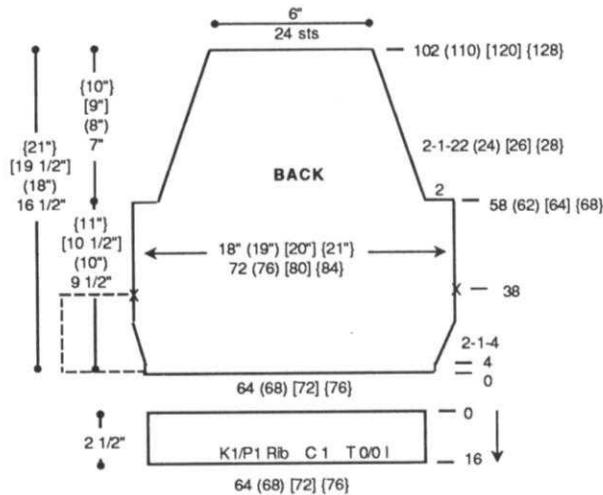

#991 - Back Color Chart

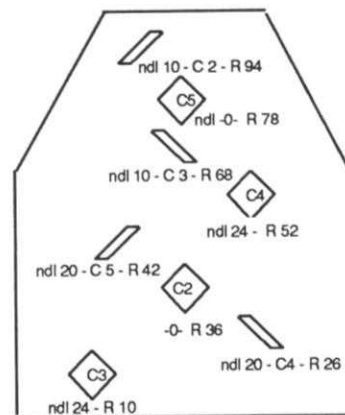

 Punch Card Patterns - Use In Order

 OR  Manual Knitting (See stitch detail chart)

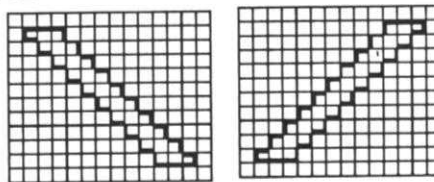

BACK WAISTBAND:

With purl side facing, rehang
lower edge of back on 64 (68)
[72] [76] ndls. With Col. 1 knit 1
row at T 4.1. Transfer EOS to RB
for K1/P1 Rib. T 0/0 I. Knit 16
Rs, knitting last row at T 8/4 and
BOLT.

FRONT: Make 1, Reverse 1.

With WY CO 32 (34) [36] [38]
sts. After several rows, end with 1
row Ravel Cord to the right.
RC 0. T 4.1. Col. 1. Follow
Color Chart and Motif Placement.
Knit 4 Rs. Shape left side by FF
incr. EOR 1 St. 4x. At R 28 (32)
[36] [40] shape neckline. On
right side FF decr. every 6 Rs. 1
St. 10x. AT THE SAME TIME at
R 38 place a YM on left side for

pocket. At R 58 (62) [64] [68]
begin raglan shaping. On left
side BO 2 Sts., then FF decr. EOR
1 St. 22 (24) [26] [28] x. At R
102 (110) [120] [128] knit 1 row
at T 10 and BOLT.

FRONT WAISTBAND: Make
2.

With purl side facing, rehang
lower edge of front on 32 (34)
[36] [38] ndls. With Col. 1 knit 1
row at T 4.1. Transfer EOS to RB
for K1/P1 Rib. T 0/0 I. Knit 16
Rs, knitting last row at T 8/4 and
BOLT.

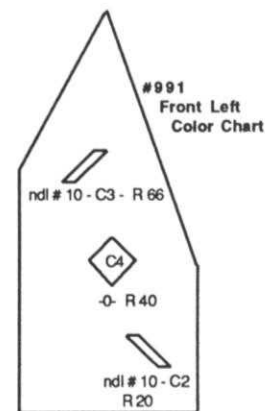
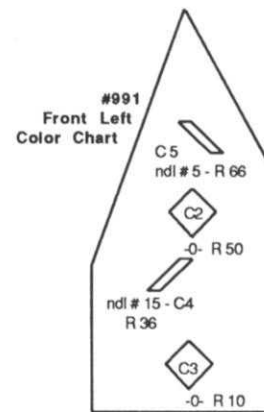
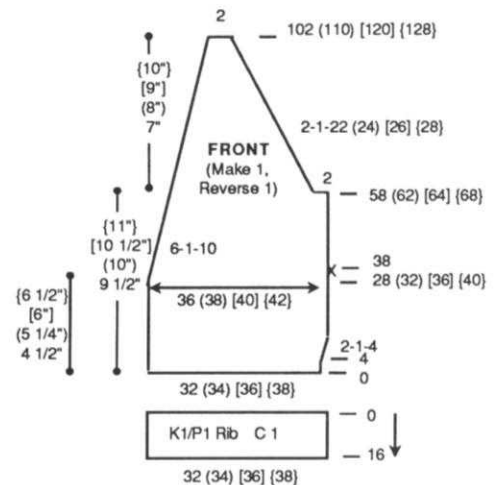

(continued next page)

(continued from previous page)

POCKET: Make 2.

With purl side facing, rehang back between pocket markers on 24 ndls. RC 0. T 4.1. Col. 1. St. St. Knit 32 Rs. Knit 1 row at T 10 and BOLT.

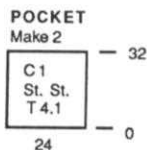

SLEEVE:

Make 2 the same.

With WY CO 24 (28) [32] [36] sts. After several rows, end with 1 row Ravel Cord to the right. RC 0. T 4.1. At R 4 knit in single motif fairisle following color chart and shape sleeve on both sides by FF incr. EOR 1 St. 12x. At R 34 (38) [40] [44] FF incr. on both sides every 5 Rs. 1 St. 4x. At R 58 (62) [64] [68] begin raglan shaping. On each side BO 2 Sts., then FF decr. EOR 1 St. 22 (24) [26] [28] x. At R 102 (110) [120] [128] knit 1 row at T 10 and BOLT.

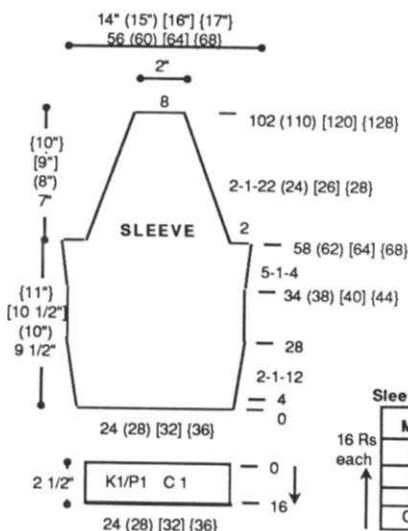

NECKBAND (Not to Scale)

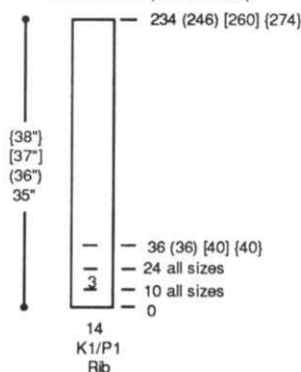

NECKBAND:

With Col. 2 CO 14 sts. for K1/P1 Rib. After selvedge RC 0. T 0.0 I. Knit to R 234 (246) [260] [274] making buttonholes over 3 sts. with WY (see chart) at Rs. 10 (10) [10], 24 (24) [24] and 36 (36) [40]. Remove sts. on WY.

SLEEVE CUFF: Make 2.

With purl side facing, rehang lower edge of sleeve on 24 (28) [32] [36] ndls. With Col. 1 knit 1 row at T 4.1. Transfer EOS to RB for K1/P1 Rib. T 0/0 I. Knit 16 Rs, knitting last row at T 8/4 and BOLT.

**#991 Fairisle Motif
24 Sts. x 60 Rows**

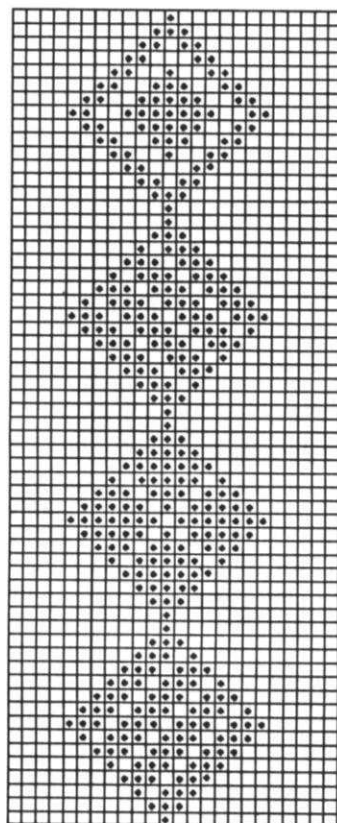

KK Magazine Disk: Tr 9; #901

FINISHING:

Close all seams. Attach neckband. Finish buttonholes with crochet hook or sewing needle. Whip stitch pocket edges to front.

knitking news

Intarsia Weaving - Pattern 981

Knitweave is a terrific technique that allows the machine knitter to achieve a wonderful textured look using fancy yarns, fabrics, or even the same yarn as used in the base knitting. When using the knitweave technique you must use weaving brushes in working position to push the weaving fiber down beneath the needles in working position. The technique results in a very stable fabric, without a lot of sideways stretch.

In Pattern 981, we have utilized the automatic needle selection capabilities when patterning. Due to the exact design selected, the color changes become quite obvious. When the pattern selects the needles you merely need to lay the weaving yarn in front of the carriage as you would for intarsia knitting, following the weaving technique in your instruction manual.

The possibilities in knitweave are endless. It provides you with a way to use wools if you can't wear wool right next to sensitive skin. Collar trims and accents in knitweave can add so much to a garment. Cost savings is another benefit weaving. Because the weaving yarn does not actually form a knitted loop you use less yarn! It's a great way to utilize those expensive novelty yarns, using a less expensive fiber as your base yarn. Enjoy knitting Pattern 981, and make knitweave a mainstay in your



MENS RAGLAN CARDIGAN

YARN: Mirage

SIZES:

Sm. (Med.) [Lge.] {X-Lge.}

AMOUNT:
 Col. 1: Navy - 1-3/4 lbs.
 Col. 2: Turquoise - 4 oz.
 Col. 3: Jade - 2 oz.
 Col. 4: White - 2 oz.
 Col. 5: Raspberry - 2 oz.

KIT PRICE: \$32.00

TENSION:

Body: T 4.1

Rib: T 0/0 I

GAUGE:

Body: 4 Sts., 6.1 Rs. = 1"

Rib: 7 Rs. = 1"

NOTIONS:

4 - 1" Buttons

Make on Compuknit/Bulky or Punch Card Bulky with Ribber.

Note: All incr. and decr. are full fashion on the third needle from edge.

Color Pattern Instructions:

Knitted manually:

1. Carr in H position.
2. Select ndls manually for color pattern (see chart). Knit these selected ndls manually, then place in HP.
3. Knit 1 R with Col. 1. Repeat Steps 2 and 3.

BACK:

With WY CO 80 (84) [88] [92] sts. After several rows, end with 1 row Ravel Cord to the right. RC 0. T 4.1. Col. 1. Follow Color Chart and Motif Placement. Knit 4 Rs. Shape sides by FF incr. on each side EOR 1 St. 4x. At R 40 place a YM on each side for pocket. At R 104 (106) [110] [112] begin raglan shaping. On each side BO 2 Sts., then FF decr. EOR 1 St. 20x and every 3 Rs. 1

St. 8x (EOR 1 St. 20x and every 3 Rs. 1 St. 9x) [EOR 1 St. 20x and every 3 Rs. 1 St. 10x] {EOR 1 St. 20x and every 3 Rs. 1 St. 11x}. At R 172 (176) [184] [188] knit 1 row at T 10 and BOLT.

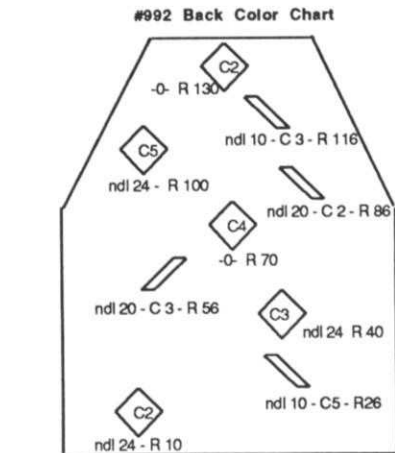
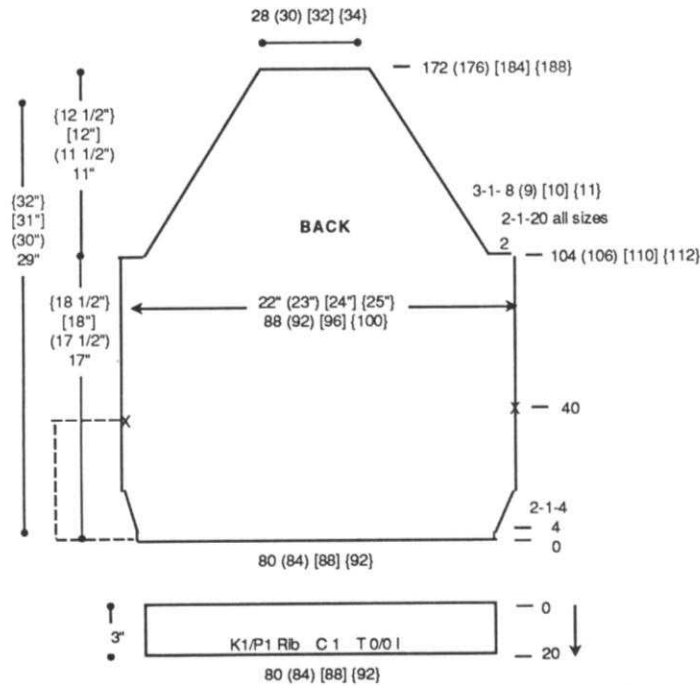

Punch Card Patterns - Use in Order
 OR Manual Knitting (See stitch detail chart)

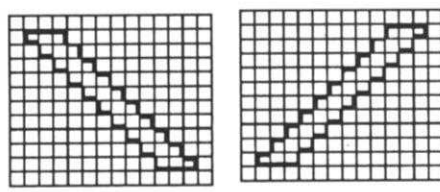

BACK WAISTBAND:

With purl side facing, rehang lower edge of back on 80 (84) [88] [92] ndls. With Col. 1 knit 1 row at T 4.1. Transfer EOS to RB for K1/P1 Rib. T 0/0 I. Knit 20 Rs, knitting last row at T 8/4 and BOLT.

FRONT: Make 1, Reverse 1. With WY CO 40 (42) [44] [46] sts. After several rows, end with 1 row Ravel Cord to the right. RC 0. T 4.1. Col. 1. Follow Color Chart and Motif Placement. Knit 4 Rs. Shape left side by FF incr. EOR 1 St. 4x. At R 40 place a YM on left side for pocket. At R 60 (60) [70] [70] shape neckline. On right side FF decr. every 5 Rs. 1 St. 12 (13) [14] [15] x. AT THE SAME TIME at R 104 (106) [110] [112] begin raglan shaping. On left side BO 2 Sts., then FF decr. EOR 1 St. 20x and every 3 Rs. 1 St. 8x (EOR 1 St. 20x and every 3 Rs. 1 St. 9x) [EOR 1 St. 20x and every 3 Rs. 1 St. 10x] {EOR 1 St. 20x and every 3 Rs. 1 St. 11x}. At R 172 (176) [184] [188] knit 1 row at T 10 and BOLT.

FRONT WAISTBAND:

Make 2. With purl side facing, rehang lower edge of front on 40 (42) [44] [46] ndls. With Col. 1 knit 1 row at T 4.1. Transfer EOS to RB for K1/P1 Rib. T 0/0 I. Knit 20 Rs, knitting last row at T 8/4 and BOLT.

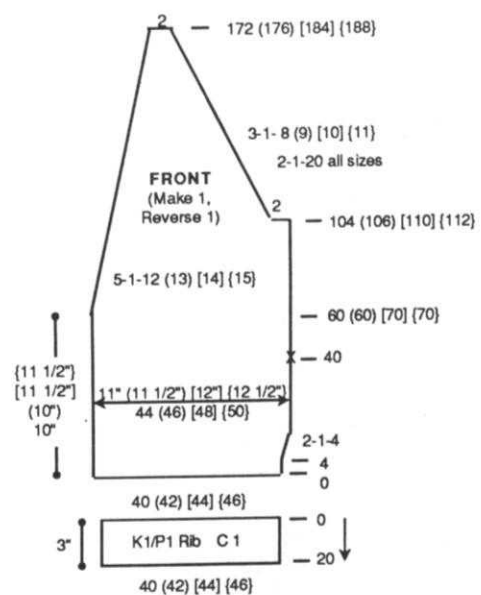
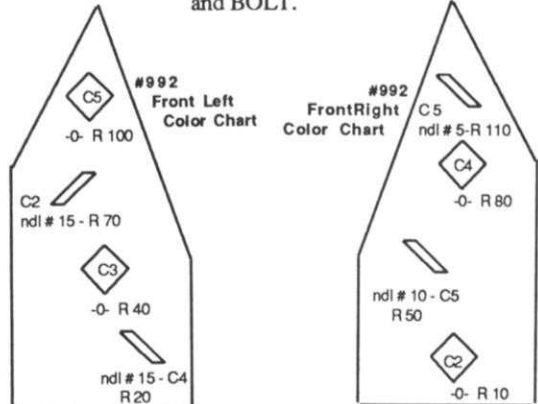

(continued next page)

(continued from previous page)

POCKET: Make 2.

With purl side facing, rehang back between pocket markers on 40 ndls. RC 0. T 4.1. Col. 1. St. St. Knit 42 Rs. Knit 1 R at T 10 and BOLT.

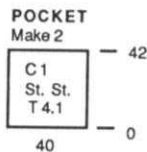

SLEEVE:

Make 2 the same. With WY CO 38 (40) [42] [44] sts. After several rows, end with 1 row Ravel Cord to the right. RC 0. T 4.1. Knit in single motif fairisle following color chart. At R 4 shape sleeve on both sides by FF incr. every 3 Rs. 1 St. 16x. At R 74 (76) [80] [82] FF incr. on both sides every 5 Rs. 1 St. 4x. At R 104 (106) [110] [112] begin raglan shaping. On each side BO 2 Sts., then FF decr. EOR 1 St. 20x and every 3 Rs. 1 St. 8x (EOR 1 St. 20x and every 3 Rs. 1 St. 9x) [EOR 1 St. 20x and every 3 Rs. 1 St. 10x] [EOR 1 St. 20x and every 3 Rs. 1 St. 11x]. At R 172 (176) [184] [188] knit 1 row at T 10 and BOLT.

SLEEVE CUFF: Make 2.

With purl side facing, rehang lower edge of sleeve on 38 (40) [42] [44] ndls. With Col. 1 knit 1 row at T 4.1. Transfer EOS to RB for K1/P1 Rib. T 0/0 I. Knit 20 Rs, knitting last row at T 8/4 and BOLT.

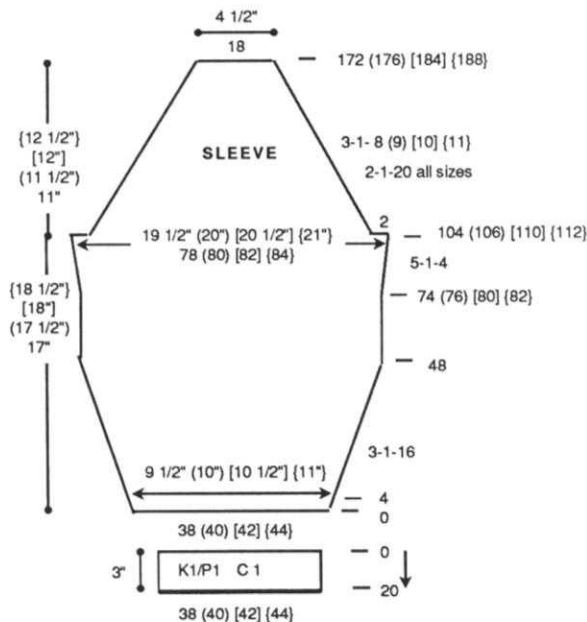

Sleeve Color Chart

Repeat
16 Rs
each

MC	CC
↑	C 5
	C 4
	C 3
C 1	C 2

NECKBAND:

With Col. 2 CO 14 sts. for K1/P1 Rib. After selvedge RC 0. T 0/0 I. Knit to R 412 (426) [440] [454] making buttonholes

NECKBAND (Not to Scale)

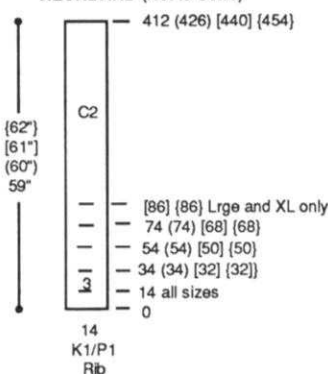

over 3 sts. with WY (see chart) at Rs. 14 (14) [[14]], 34 (34) [[32]], 54 (54) [[50]], and 74 (74) [[68]] and [[86]]. Remove sts. on WY.

**#992 Fairisle Motif
24 Sts. x 60 Rows**

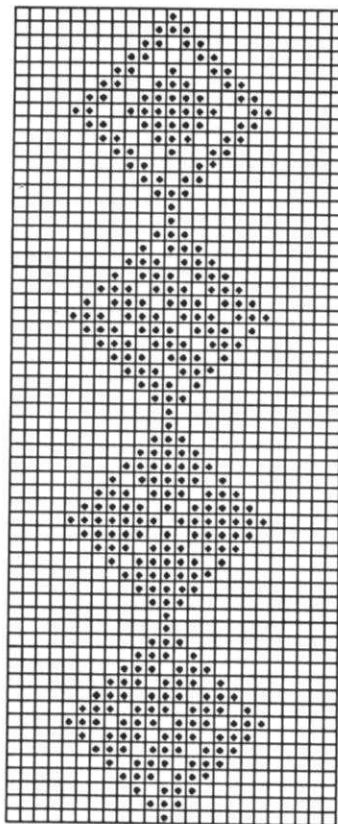

KK Magazine Disk: Tr 9; #901

FINISHING:

Close all seams. Attach neckband. Finish buttonholes with crochet hook or sewing needle.

993

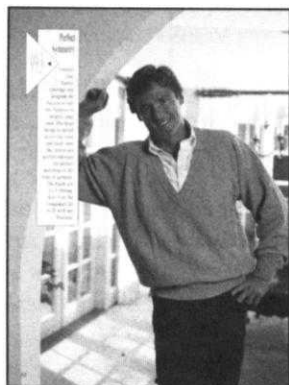

**MENS G-CARRIAGE
V-NECK PULLOVER**

YARN: Woolana
(2 strands throughout)

SIZES:

Small (Medium) [Large]

AMOUNT:

Periwinkle - 2 lbs. all sizes

KIT PRICE: \$60.00

TENSION:

Body: T 7

Rib: T 2

GAUGE:

Body: 7.34 Sts., 10.96 Rs. = 1"

Make on Compuknit III/IV with Garter Carriage.

Pattern Note:

Pattern for ribbing is #532 in the

Compuknit III/IV Pattern Book. Variation Key # 5 (upside down) is used for half of sleeve.

BACK:

CO 160 (168) [176] sts. at T 3. RC 0. T 2. Set GC for rib pattern and knit to R 40. RC 0. T 7. Set Garter Carriage for body pattern. Knit to R 132 (144) [148] and mark each side with YM for armhole. (Note pattern row in window for sleeve). Continue in pattern to R 252 (264) [274]. Mark center 52 (56) [60] sts. for neck opening and remove neckline and shoulder sts. on separate WY.

FRONT:

Knit front same as back to R 114 [(126)]. Shape neckline. Knit all sts. to the left of -0- manually to "A" (out of work) position on Ravel Cord. *Note pattern row.* *On right side decr. every 4 Rs. 1 St. 26 (28) [30] x. AT THE SAME TIME at R 132 (144) [148] and mark each side with YM for armhole. At R 252 (264) [274] remove shoulder sts. on WY. Reset RC to R 114 [(126)]. Return sts. to the left of -0- to WP. Reset pattern to correct row. Shape left neckline same as right from *. Remove shoulder sts. on WY.

follows: EOR 5 Sts. 10 (6) [2] x and 6 Sts. 13 (17) [21] x. At R 46 Ravel Cord will be completely removed. Continue in pattern to R 120 (120) [126]. Mark each side with YM for center. Activate Variation Key # 5 (upside down). Continue to R 194 (194) [206] and begin SHR shaping with Ravel Cord on right side as follows: EOR 6 Sts. 13 (17) [21] x and 5 Sts. 10 (6) [2] x. SHR completed at R 240 (240) [252]. Remove sts. on WY.

To reverse the second sleeve, begin on Ndl. # 61 (57) [53] on right and # 67 (75) [83] on left.

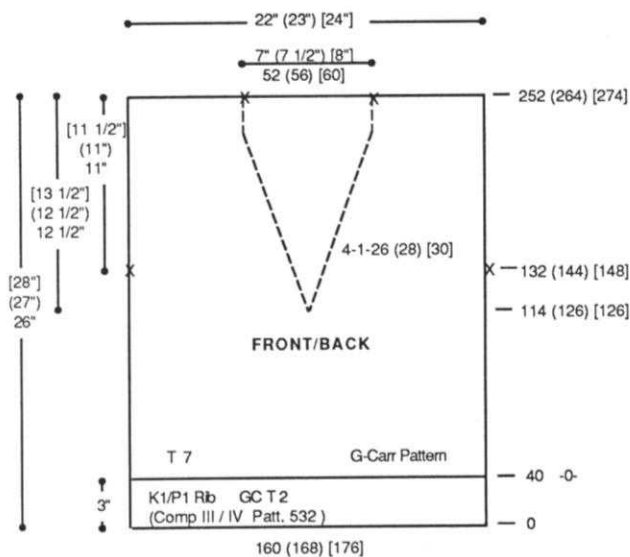
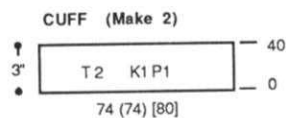

NECKBAND: Make in two pieces. Close one shoulder first.

Back/1/2 Front:

CO 146 (150) [160] sts. at T 3 as shown on chart. RC 0. Change to T 2. Set GC for rib pattern. On left side decr. every 4 Rs. 2 Sts. 4x and then incr. every 4 Rs. 2 Sts. 4x. At R 32 rehang back neck opening and half of front neck on these ndls. Knit 1 row loosely by hand and BOLT.

1/2 Front:

Knit same as Back/1/2 Front except CO 94 (94) [100] sts. and shape on the right side.

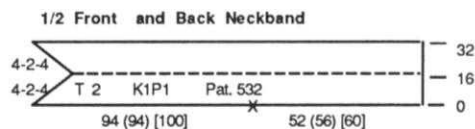

SLEEVE:

Make 1, Reverse 1.

The sleeves are knit sideways. In order to match the sleeve pattern to the pattern of the body, it is important to begin the sleeve on the Ndl and pattern R you made note of from garment body.

All sizes: To assure the pattern will match on both sides of the shoulder seam, in the center of the sleeve, the pattern is advanced 2 Rs, to compensate for the 2 Rs of pattern which are in the shoulder seam.

With WY and K-carriage CO starting with ndl. # 61 (57) [53] on left and ndl. # 67 (75) [83] on right. After a minimum of three inches of WY, ending with K-carriage on right, at T 7 knit 1 R with main yarn to the left. Knit 1 row manually to "A" (out of work) position on Ravel Cord. Change to Garter Carriage on left side. RC 0. T 7. Advance pattern to appropriate row. Work short rows from left to right placing sts. to "B" position and removing Ravel Cord on these sts. as

SLEEVE
(Make 1, Reverse 1 — Shape & Pattern)

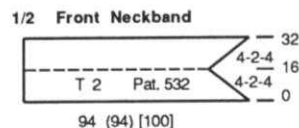
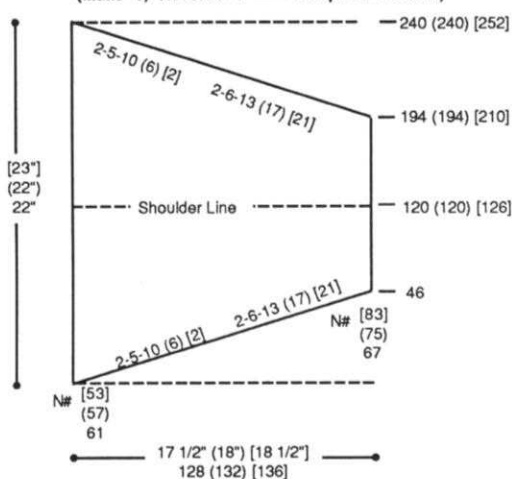

CUFF:

At T 3 CO 74 (74) [80] sts. RC 0. Change to T 2. Set GC for rib pattern and knit to R 40. With purl side facing, rehang the bottom edge of sleeve on these ndls. Knit 1 row loosely by hand and BOLT.

(continued next page)

#993 Mens G-Carriage V-Neck Pullover
70 Sts. x 112 Rows

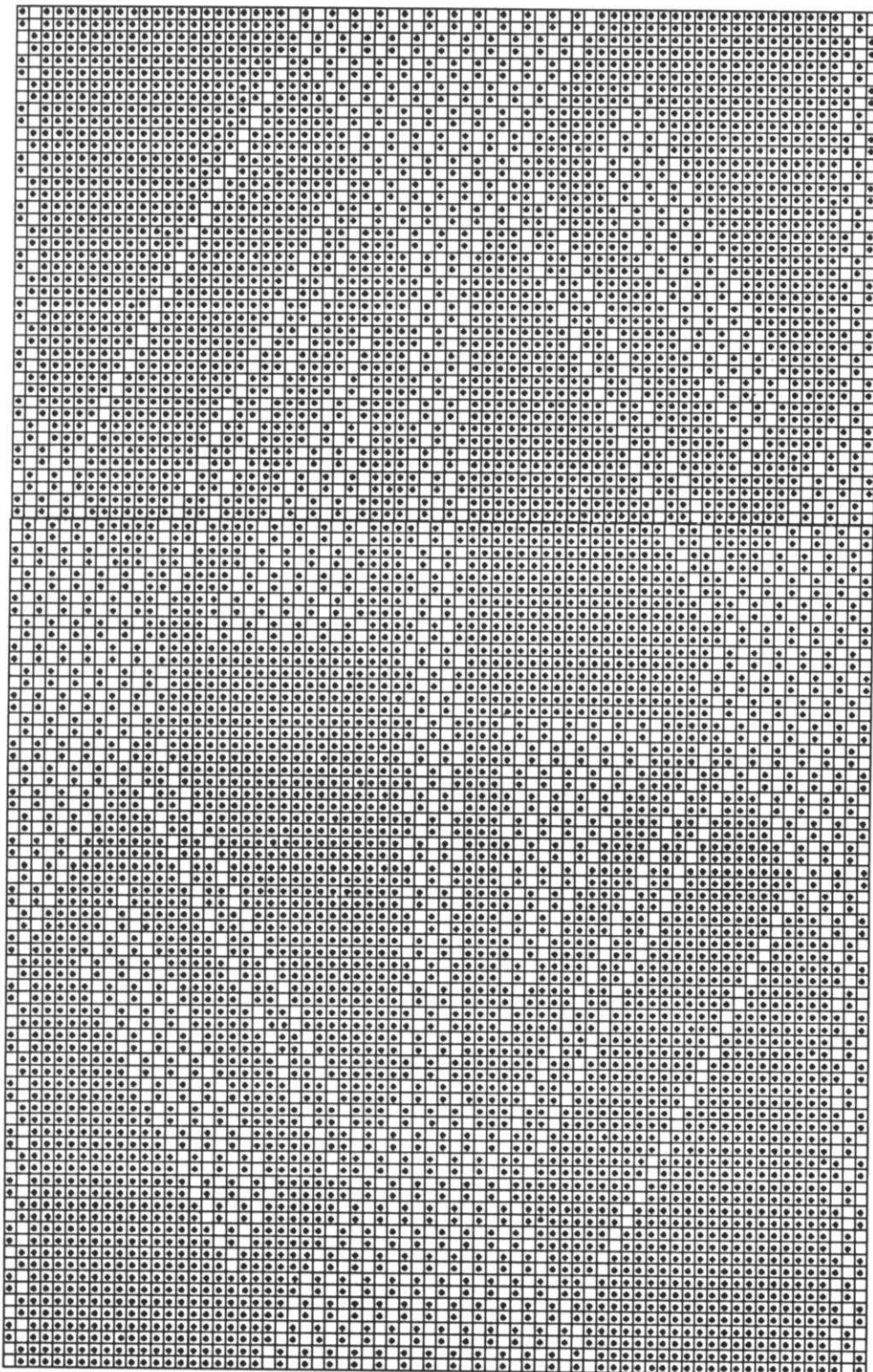

KK Magazine Disk: Tr 10; #901

FINISHING:
Close all remaining seams. Fold neckband to inside and whip stitch in place.



WOMENS FAIRISLE PULLOVER

YARN: Venetia

SIZES:

Small (Medium) [Large]

AMOUNT:

- Col. 1: Black - 1 lb.
- Col. 2: Light Blue - 2 oz.
- Col. 3: Pink - 3 oz.
- Col. 4: Corn - 2 oz.
- Col. 5: Grey - 2 oz.
- Col. 6: Mandarin - 2 oz.
- Col. 7: Iced Stream - 2 oz.

KIT PRICE: \$52.50

TENSION:

- Body: T 6
- Rib: T 1/1 I

GAUGE:

- Body: 8.3 Sts., 12.92 Rs. = 1"
- Rib: 14 Sts., 15 Rs. = 1"

Make on Standard 24-Stitch Punch Card or Standard Electronic Machine. For owners of Stitch Pattern Cartridge Extras, use pattern on P = 1, #915.

BACK:

With Col. 1 CO 174 (182) [192] sts. for K2/P2 Rib. After selvedge RC 0. T 1/1 I. Knit to R 60. Transfer RB sts. to MB. RC 0. T 6. Knit in pattern following Color Chart while incr. on each side every 10 Rs. 1 St. 4x. At R 170 (178) [190] place a YM on each side for armhole. Knit to R 300 (314) [326]. SHR shoulders EOR 10 Sts. 5x. At R 310 (324) [336] mark center 60 (62) [68] sts. with YM for neckline. Knit 1 row at T 10 and BOLT.

FRONT:

Knit front same as back to R 264 (278) [290]. Begin neckline shaping. Place center 30 (32) [38] sts. in HP and all sts. to the left in HP. Note pattern row. *On neckline edge SHR EOR 3 Sts. 2x,

2 Sts. 4x and 1 St. 1x. At R 300 (314) [326] SHR shoulder same as back. At R 310 (324) [336] knit 1 row over shoulder sts. at T 10 and BOLT. Reset RC to R 264 (278) [290]. Reset pattern to correct row. Shape left side from *, reversing shapings. Remove neckline sts. on WY.

every 5 Rs. 1 St. 39 [(40)] x. At R 200 [(206)] knit 1 R at T 10 and BOLT.

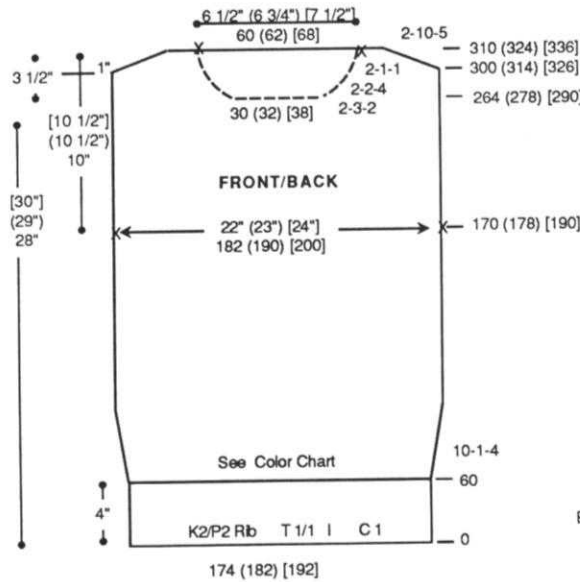

Color Chart

Rs	MC	CC
10	C 1	C 2
8		C 3
6		C 4
6		C 3
6		C 5
8		C 6
10		C 7
8		C 3
	Cont.	Repeat

SLEEVE:

Make 2 the same. With Col. 1 CO 82 [(86)] sts. for K2/P2 Rib. After selvedge RC 0. T 1/1 I. Knit to R 40 and remove on WY. Bring 88 [(94)] ndls. on MB to WP and rehang ribbing incr. evenly across. RC 0. T 6. Knit in pattern following Color Chart while incr. on each side

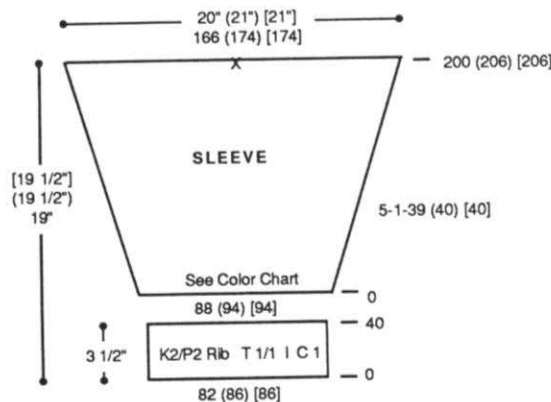

NECKBAND:

With Col. 1 CO 186 (192) [200] sts. for K2/P2 Rib. After selvedge RC 0. T 1/1 I. Knit to R 32. Remove on WY. CLOSE ONE SHOULDER. Bring 186 (192) [200] ndls. on MB to WP. With purl side facing, rehang neckline on these ndls. Rehang ribbing on these same ndls. Knit 1 R at T 10 and BOLT.

NECKBAND

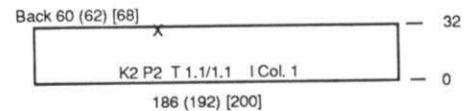

**#994 Fairisle
24 Sts x 60 Rows**

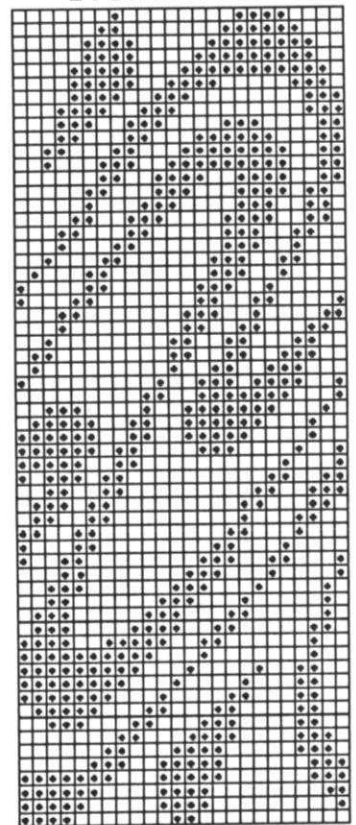

KK Magazine Disk: Tr 11; #901

FINISHING:

Close all seams.

995



CABLE FRONT PULLOVER with LACE SLEEVES

YARN: Softon

SIZES:

6/8 (10/12) [14]

AMOUNT:

Col. 1: Turquoise

(2 Strands together throughout)

1 lb. (1 lb.) [1 lb. 2 oz.]

KIT PRICE:

\$20.00 (\$20.00) [\$23.00]

TENSION:

Body: T 5 Bulky

Sleeve: T 9 Standard

Rib: T -0/-0 I Bulky

GAUGE:

Body: 4.67 Sts., 6.3 Rs. = 1"

Sleeve: 15 Sts., 6.47 Rs. = 1"

Make on Standard 24-Stitch Punch Card or Standard Electronic Machine and any Bulky Machine with Ribber. Pattern is # 104 in Compuknit III/IV Pattern Book and Stitch Pattern Cartridge Extras pattern P=7, #928.

BACK: (No cables)

With Col. 1 CO 90 (94) [98] sts. for K1/P1 Rib. After selvedge RC 0. T -0/-0 I. Knit to R 30. Transfer RB sts. to MB and remove outside 12 [(12)] sts. on each side on WY. RC 0. T 5. St. St. Knit to R 112 [(118)]. SHR shoulders EOR 5 Sts. 3x. At R 120 [(126)]. Mark center of 34 sts. with YM for neck opening. Knit 1 row at T 10 and BOLT.

#995 Lace Pattern

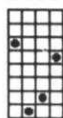

KK Magazine Disk:
Tr 12; #901

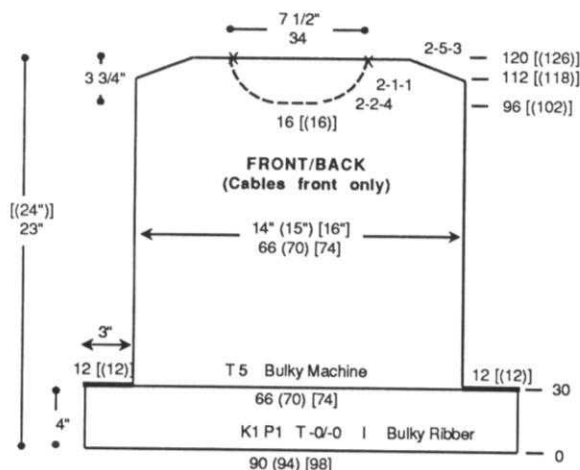

CABLE ROW CHART

R 136
R 130
R 118
R 112
R 100
R 96
R 84
R 78
R 66
R 60
R 48
R 42
R 30
R 24
R 18
R 6

FRONT:

(See Chart for cables)

Knit same as back, with cable set-up (see chart) to R 96 [(102)]. Begin neckline shaping. Place center 16 [(16)] sts. in HP and all sts. the left in HP. *On neckline edge SHR EOR 2 Sts. 4 x and 1 St. 1x. At R 112 [(118)] SHR shoulder EOR 5 Sts. 3x. At R 120 [(126)] knit 1 row at T 10 and BOLT. Reset RC to R 96 [(102)]

#995 CABLE CHART

FRONT - CABLE CROSSES (See Chart for Row ■ - Alternate middle cable)

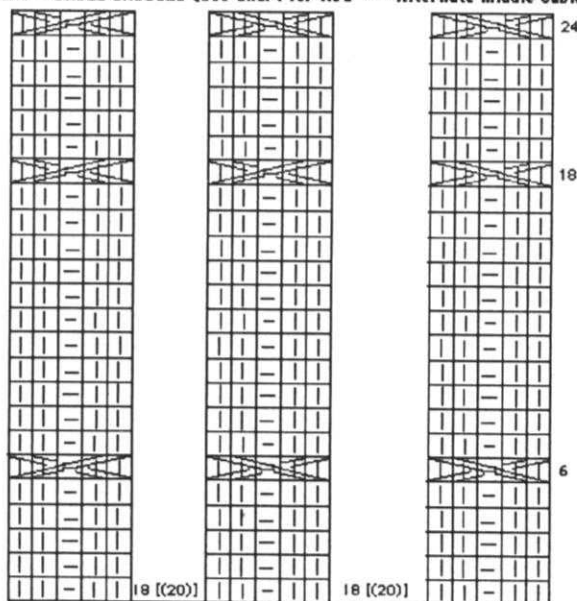

and shape neckline and shoulder from *, reversing shapings. Knit 1 row over neckline sts. at T 10 and BOLT.

SLEEVE:

Make 2 the same.

With WY CO 94 [(100)] sts. After several rows, end with 1 row Ravel Cord to the left. Col. 1. T 9. Knit 1 row to set lace pattern. RC 0. Shape sleeve by incr. on each side every 4 Rs. 1 St. 10 [(10)] x and EOR 1 St. 18 [(20)] x. At R 76 [(80)] 'e' wrap CO 20 [(20)] sts. on each side. Knit to R 104 [(110)]. Mark center for center of shoulder seam. Knit 1 row manually at a loose tension and BOLT.

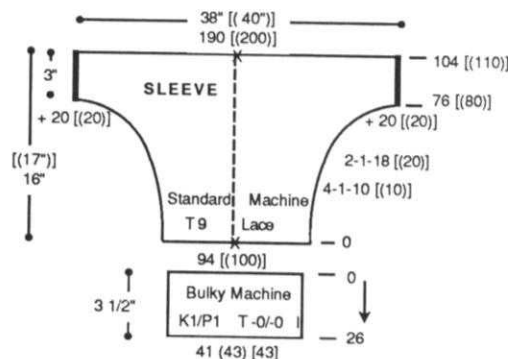

CUFF:

Rehang lower edge of sleeve on 41 [(43)] ndls. Transfer EOS to RB for K1/P1 Rib. With T -0/-0 I. Knit to R 26, knit 1 R at T 8/4. Transfer RB sts. to MB and BOLT.

FINISHING:

Close all seams. With 2 strands of Col. 1 Single Crochet around neckline.

996



SHORT SLEEVE TUCK PULLOVER

YARN: Primo and Roma

SIZES:

6/8 (10/12) [14]

AMOUNT:

Col. 1: Primo - White - 1 lb.

Col. 2: Roma - White - 1 lb.

Col. 3: Primo - Turquoise - 1 oz.

KIT PRICE: \$35.50

TENSION:

Tuck: T 10

Rib: T 6/6 I

GAUGE:

Tuck: 6.3 Sts., 11.26 Rs. = 1"

Make on Standard 24-Stitch Punch Card or Standard Electronic Machine with Ribber. Pattern is #234 in Compuknit III/IV Pattern Book.

Note: Sweater is worn on the purl side.

BACK:

With Col. 3 (2 strands) CO 120

(126) [132] sts. for K1/P1 Rib.

After selvedge RC 0. T 6/6 I.

Knit to R 4. Change to Col. 1 and

Col. 2. Knit to R 36. Transfer RB sts. to MB. RC 0. T 10. Tuck Pattern. Knit to R 102 (114) [120] and shape armhole. On each side BO 5 sts., decr. EOR 1 St. 5x and every 4 Rs. 1 St. 3x. At R 192 (204) [216] SHR shoulders EOR 6 Sts. 4x. At R 202 (214) [226] mark center 44 sts. with YM for neckline. Knit 1 row manually at a loose tension and BOLT.

FRONT:

Knit front same as back to R 132 (144) [156]. Shape neckline. Place all sts. to the left of -0- in HP. Note pattern row. *On neckline edge decr. EOR 1 St. 4x and every 3 Rs. 1 St. 18x. AT THE SAME TIME at R 192 (204) [216] SHR shoulder EOR 6 Sts. 4x. At R 202 (214) [226] knit 1 row manually at a loose tension and BOLT. Put left side sts. into WP. Reset RC to R 132 (144) [156]. Reset pattern to correct row. Shape neckline and shoulder from *, reversing shapings.

*996 Tuck Pullover Compuknit III/IV Pattern 234 6 Sts. x 30 Rows

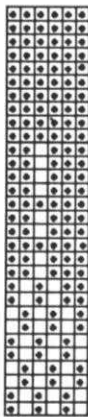

SLEEVE:

Make 2 the same.

With Col. 3 (2 strands) CO 68 (72) [76] sts. for K1/P1 Rib. After selvedge RC 0. T 6/6 I. Knit to R 4. Change to Col. 1 and Col. 2. Knit to R 20 and remove sts. on WY. Bring 100 (100) [104] ndls. on MB to WP and rehang ribbing incr. evenly across. RC 0. T 10. Col. 1 and Col. 2. Tuck Pattern. Knit to R 26 (30) [34] and shape sleeve cap. On each side BO 5 sts., decr. every 4 Rs. 1 St. 5x and every 6 Rs. 1 St. 7x. At R 88 (92) [96] SHR EOR 3 Sts. 5x. At R 98 (102) [106] knit 1 row manually at a loose tension and BOLT.

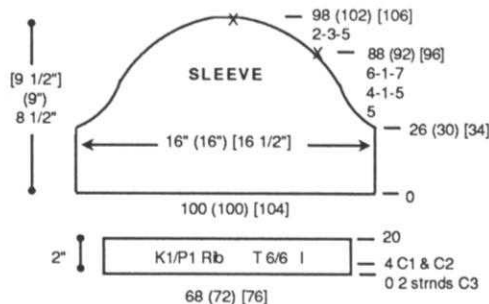

COLLAR:

With Col. 3 (2 strands) CO 175 (175) [175] sts. for K1/P1 Rib. After selvedge RC 0. T 6/6 I. Knit to R 4. Change to Col. 1 and Col. 2. Knit to R 30. On each side SHR EOR 10 Sts. 4x. At R 40 knit 1 row manually at a loose tension and BOLT.

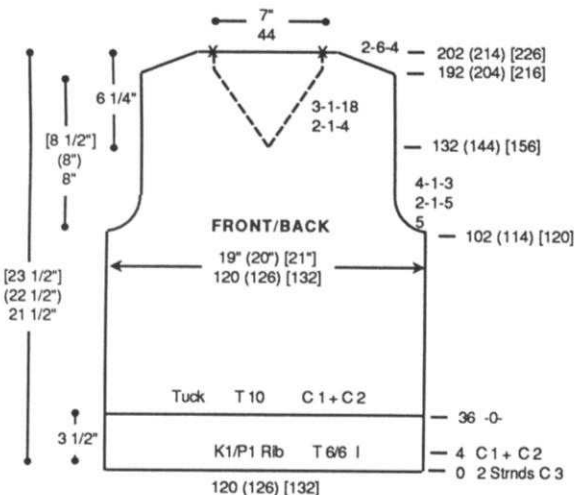
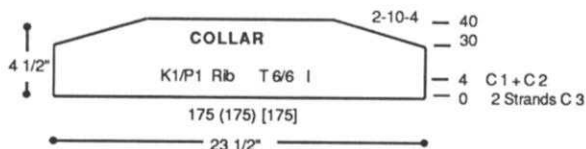

FINISHING:

Close all seams. Attach collar and join front seam 3/4" from neckline. With Col. 2 (2 strands) finish front edge of collar by repeating 1 single crochet and 1 chain st. around.

Knitkng Sizing Chart

MISSES

Size	6	8	10	12	14	16	18
Bust	30 1/2	31 1/2	32 1/2	34	36	38	40
Waist	22	23	24	25 1/2	27	29	31
Hip	32 1/2	33 1/2	34 1/2	36	38	40	42
Back Waist Length	15 1/2	15 3/4	16	16 1/4	16 1/2	16 3/4	17
Shoulder to Shoulder	13 1/2	13 1/2	14	14 1/2	15	15 1/2	16
Armhole Depth	7	7	7 1/2	7 1/2	7 1/2	8	8
Sleeve Length Under Arm	16 1/2	16 1/2	17 1/2	17 1/2	17 1/2	18	18

These are actual body sizes. Proper ease allowance is necessary as determined by the style.

CHILDREN

Size	12 mo	2 yr	4	6	8	10	12
Chest	19	21	23	25	27	28	30
Waist	19	20	21	22	23	24	25
Hip	20	22	24	26	28	30	32
Back Waist Length	7	8 1/2	9 1/2	10 1/2	12 1/2	14	15
Shoulder to Shoulder	7 1/2	8 1/2	9 1/2	10	11	11 1/2	12
Armhole Depth	3 1/2	4	5 1/2	6	6 1/2	6 1/2	7
Sleeve Length Under Arm	6	7 1/2	9 1/2	10 1/2	12	13 1/2	15

These are actual body sizes. Proper ease allowance is necessary as determined by the style.

Mens

Size	34	36	38	40	42	44
Chest	34	36	38	40	42	44
Waist	30	32	34	36	38	40
Hip	35	37	39	41	43	45
Back Waist Length	15 1/2	15 1/2	16	16 1/4	16 1/4	16 1/4
Shoulder to Shoulder	15 1/2	16	16 1/2	17	17 1/2	18
Armhole Depth	8	8 1/2	9	9 1/2	10	10 1/2
Sleeve Length Under Arm	19	19 1/2	19 1/2	20	20	20 1/2

These are actual body sizes. Proper ease allowance is necessary as determined by the style.

IS YOUR ADDRESS CHANGING ?

If so, you can insure the proper handling of this change by following the three suggestions below:

- 1) When advising us of your new address, please also indicate your old address.
- 2) Please provide us with six weeks notice to affect this change.
- 3) PLEASE PRINT ALL INFORMATION LEGIBLY.

WOMENS

Size	38	40	42	44
Bust	42	44	46	48
Waist	34	36	38	40 1/2
Hip	44	46	48	50
Back Waist Length	17 1/4	17 1/2	17 1/2	17 3/4
Shoulder to Shoulder	16 1/2	17	17 1/2	18
Armhole Depth	8 1/4	8 1/4	8 1/4	8 1/2
Sleeve Length Under Arm	18 1/2	18 1/2	18 1/2	18 1/2

These are actual body sizes. Proper ease allowance is necessary as determined by the style.



The finest quality KNITKING yarns are used to create the beautiful fashions found in KNITKING Magazine. Photographic representations may not accurately reflect the true color of the yarn due to lighting and printing processes. Please refer to your Knitkng Yarn Color Book for actual colors. Kit prices are located with the instructions for each garment. Each yarn comes in a wide selection of colors. The different types of yarns have been selected to allow for blending, mixing, and contrasting—both color and texture. Yarn Color Book is available through KNITKING or an authorized Knitkng dealer. Content and approximate yardage of each yarn is included in the chart below:

	Yds./Pound	Price/Ounce	Yds./Pound
Alpine _____ 100% Wool	1600	Pearlyte _____ 100% Rayon Boucle	2200
Angora _____ 100% Rabbit Hair (10 gr. ball)	33 yds/ball	Pebble _____ Boucle Cotton/Acrylic/Rayon	700
Angora/Wool _____ 70% Angora/30% Wool	1750	Primo _____ 100% Mercerized Cotton	2500
Acrylite _____ 2/12 Acrylic	2400	Rayon Nubs _____ 100% Rayon Nub Filler Yarn	5500
Caprinae _____ 78% Mohair/13% Wool/9% Nylon	980	Roma _____ 80% Acrilan/20% Antron	2600
Glance _____ 100% Slinky Bright Rayon	2400	Rubane (50 gr ball) 100% Polyamid 1/8" ribbon	82/ball
Glance Plus _____ 100% Slinky Bright Rayon	1650	Silkie _____ 2-Ply Orlon	2100
Ice Cream _____ 54% Cotton/46% Rayon	2100	Softon _____ 100% Soft Cotton	2000
Lumiyarn _____ Thin Metallic Yarn (50 gr. cone)	1200/cone	Sorbet _____ 54% Cotton/46% Rayon	2200
Mini Acrylite _____ 2/24 Weight 100% Acrylic	3600	Starlite _____ Acrylic w/Metallic Thread	2400
Mini Pebble _____ 100% Rayon Slub Filler Yarn	3350	Venetia _____ 70% Wool/30% Rayon	2400
Mirage _____ 100% 4-Ply Worsted Acrylic	1000	Wings _____ 100% Polyester Filler Fluff	2600
Night Music _____ Polyester Thread w/Metallic Twist	115/ball	Woolana _____ 100% 2/12 Merino Wool	3000
Panache _____ 100% 3-ply Acrylic	2400	Knit-in Elastic _____ 79% Nylon/21% Elastic	430/spool

Yarn Color Book: \$25.00 + Shipping and Handling

Order your Knitkng kits in the color of your choice from Knitkng color cards. Kit and yarn prices subject to change without notice.



Significant Twosome

▶ 986

Clever match-mates take top honors. Hers is a lovely Dress, his a magnificent Pullover. Both are knitted with striped sections in a Tuck Rib pattern on a standard Punch Card or Electronic machine with Ribber. The Belt and Collar of dress is in full needle rib. The bands on Mans Pullover are 1 x 1 ribbing. Venetia is the yarn.

▶ 987

988

Positive and Negative

A charming two-piece Dress has a special feature on the Fair Isle Top. The design is split down the center, reversing colors for a positive/negative effect created on the Pattern Design Computer...and it's all in one piece. Colors are reversed for each sleeve. Bands are 1 x 1 Ribbing. The slim Skirt is in Stockinette stitch. Make it on the Compuknit III or IV with Venetia.



Important Texture

989

A smart bulky Jacket has a lovely texture that is easy to obtain. It is knitted sideways and you turn the knitting every ten rows, changing the yarn as specified in pattern. The wide double breasted front panels, Collar and sleeve bands are 1 x 1 ribbing. Knit it on any Bulky machine with Ribber, Pebble, Acrylite and Softon are the yarns.



Double the Fun

990

Each of these sweaters can be knitted for a Boy or a Girl.

991

The isolated Fair Isle Motifs are spaced at random on the fronts and are isolated up the center of Sleeves. Waist and sleeve bands are 1 x 1 ribbing as is the front bands on Boys Cardigan and Collar of Girls Pullover. Full fashion shaping makes decorative raglan seams.

The yarn is Mirage and you can knit them on a Punch Card or Electronic Bulky with Ribber.





A Sportman's Cardigan

▶ 992

Similar to the Boys Cardigan, Dad will love his version. Colorful isolated Fair Isle Motifs are spaced at random on the front sections and isolated up the center of sleeves. The bands are 1 x 1 ribbing. Knit it with Mirage on a Punch Card or Electronic Bulky machine with Ribber.

Perfect Symmetry

993

Connect your Garter Carriage and program the Pattern to knit this Pullover to surprise your man. The large design is spread across the front and back, then the sleeves are knitted sideways for perfect matching on the body of garment. The bands are 1 x 1 ribbing. Knit it on the Compuknit III or IV with our Woolana.





Spectacular

▶ 994

An impressive Pullover to please anyone is made in a Fair Isle Design that includes soft pastel color stripes throughout the design. The Bands and Collar are 2 x 2 ribbing. Knit it with Venetia on a standard Punch Card or Electronic machine.

Pretty Combination

995

Knit the front and back of an exceptional Pullover in Stockinette stitch with Cables on the front section using any bulky machine. The cables are spaced six and twelve rows apart. Knit the lacy sleeves on a standard machine with Lace Carriage. Bands are 1 x 1 ribbing. Perfect for spring and summer in our Softon yarn.





Feminine Delicacy

▶ 996

Everyone needs a Pullover that can be packed for travel and this one will meet with your approval. It's made in an easy Tuck stitch Pattern and is worn on the purl side. The sleeves are slightly puffed. Collar and bands are 1 x 1 ribbing with a contrast color edging. Knit it on the Punch Card or Electronic standard gauge machine with Ribber. The yarns are Roma and Primo.

**Announcing the finest selection of quality yarns—
with simply the best prices and support
available anywhere...**

 **yarns by
knitking**
The First Name in Machine Knitting



**Exciting New Knitking Yarn Book-Only \$25.00
The perfect way to select your yarns and colors**

Unsurpassed Selection and Quality

With over 25 different yarns and over 250 different colors in the Knitking line, you have a variety to choose from for any and all needs. The yarns include a wide selection of natural fibers and blends, along with acrylics and acrylic blends in varying weights. There are fine filler yarns for blending, elastic for knitting in and a wide array of colors and textures in all types.



Unsurpassed Support

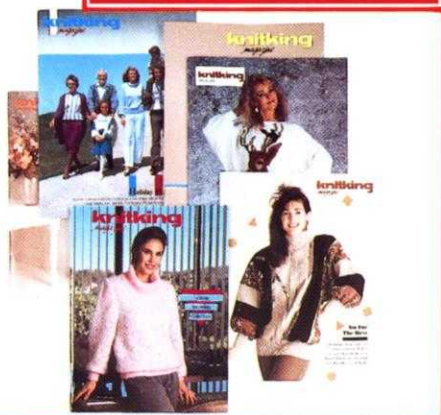

No yarn company in the world can match Knitking's support for its customers. For 25 years, Knitking has published the internationally-acclaimed **Knitking Magazine**. Each quarterly full-color issue contains at least 20 original fashions **made exclusively with Knitking Yarns**, complete with clear instructions for machine knitting.

And At Prices Well Below The Competition

Order the exciting Knitking Yarn Book today for only \$25.00 from your local Knitking Dealer, or if you do not have one in your area, from:



1128 Crenshaw Blvd., Los Angeles, CA 90019 • Phone (213) 938-2077