

knitking

magazine

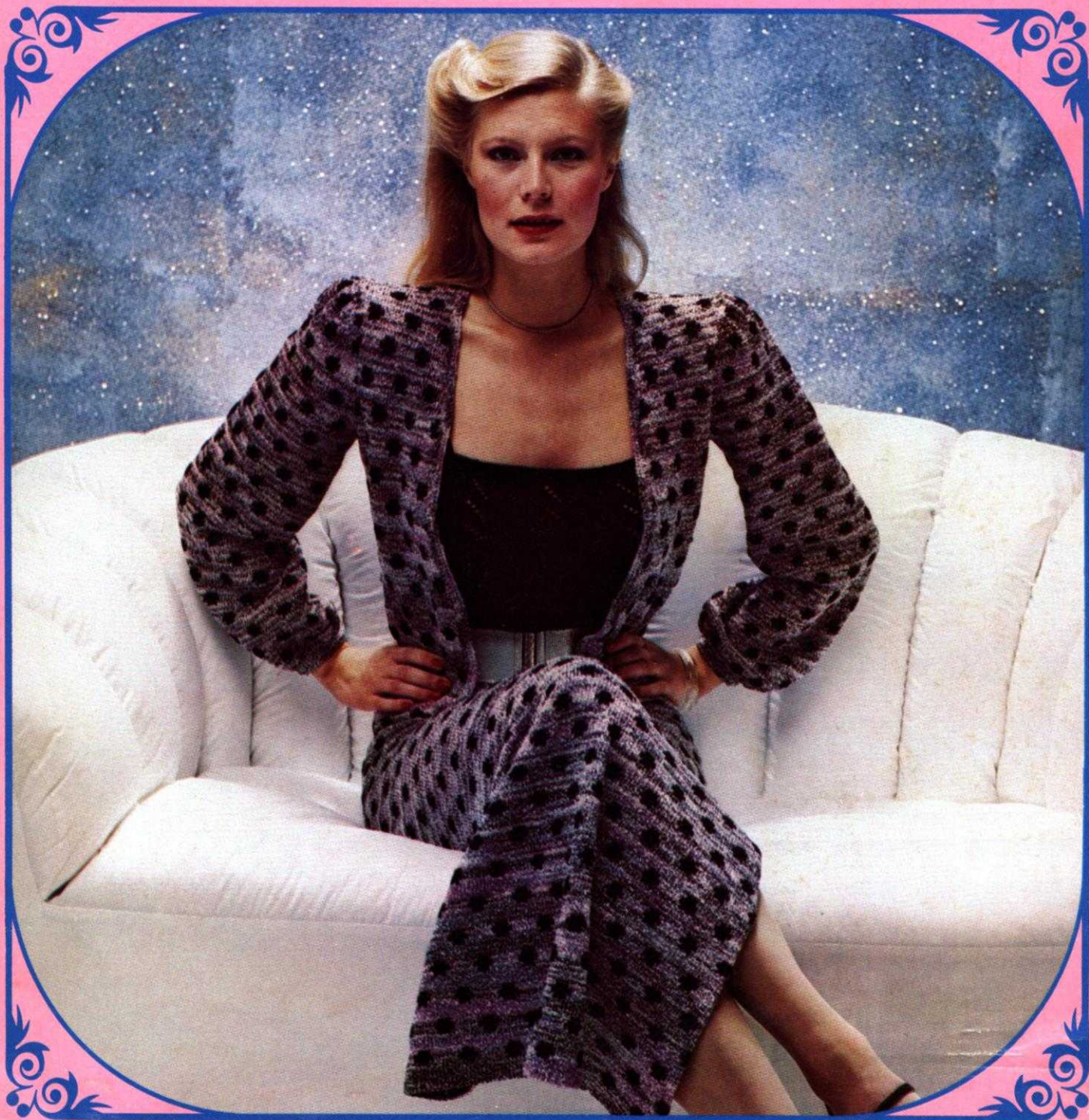

കുറുപ്പ്



OK 813

OK 012

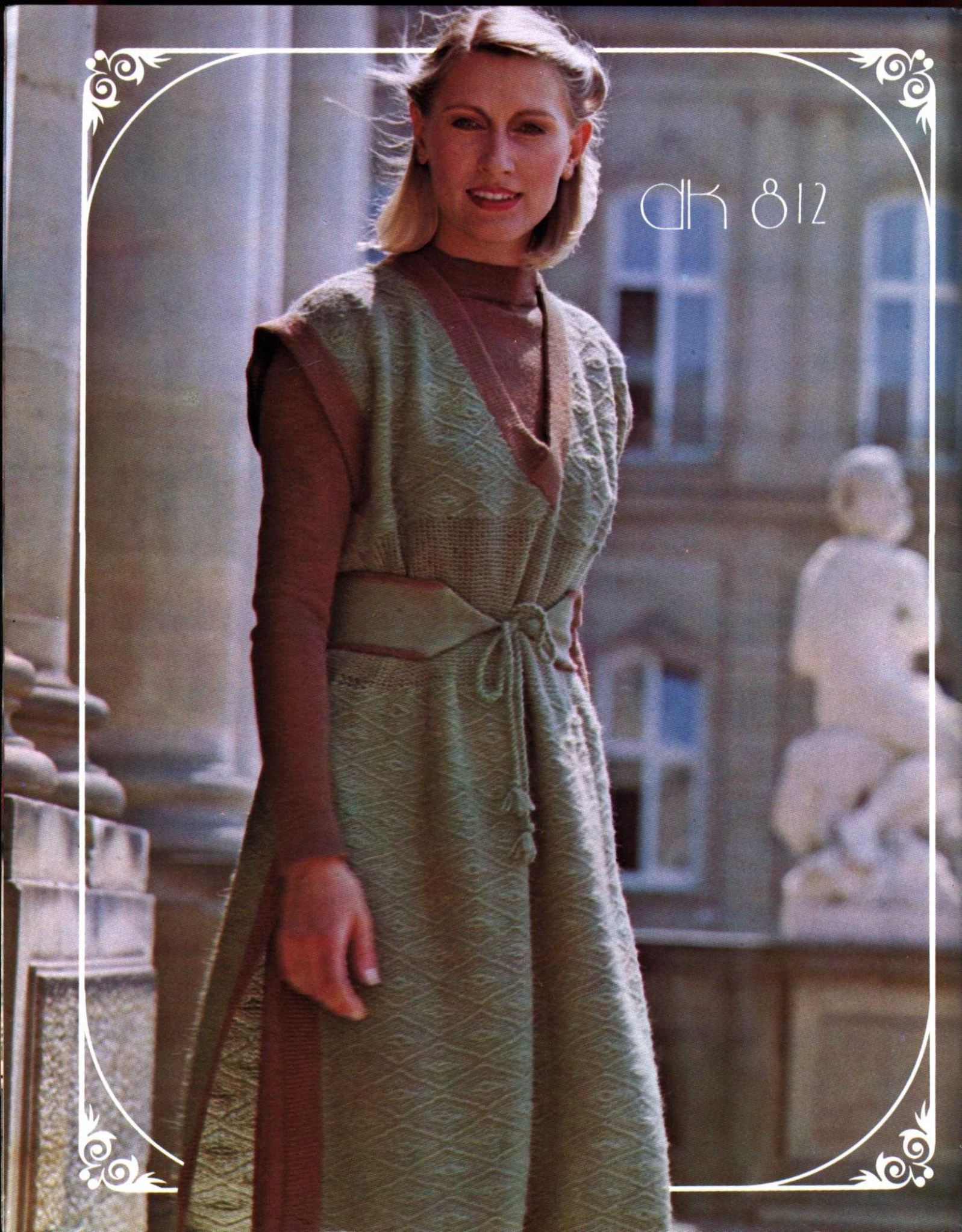



dk 798



dk 000



DK 809



dk 807

dk 8013



OK 794

hp 810

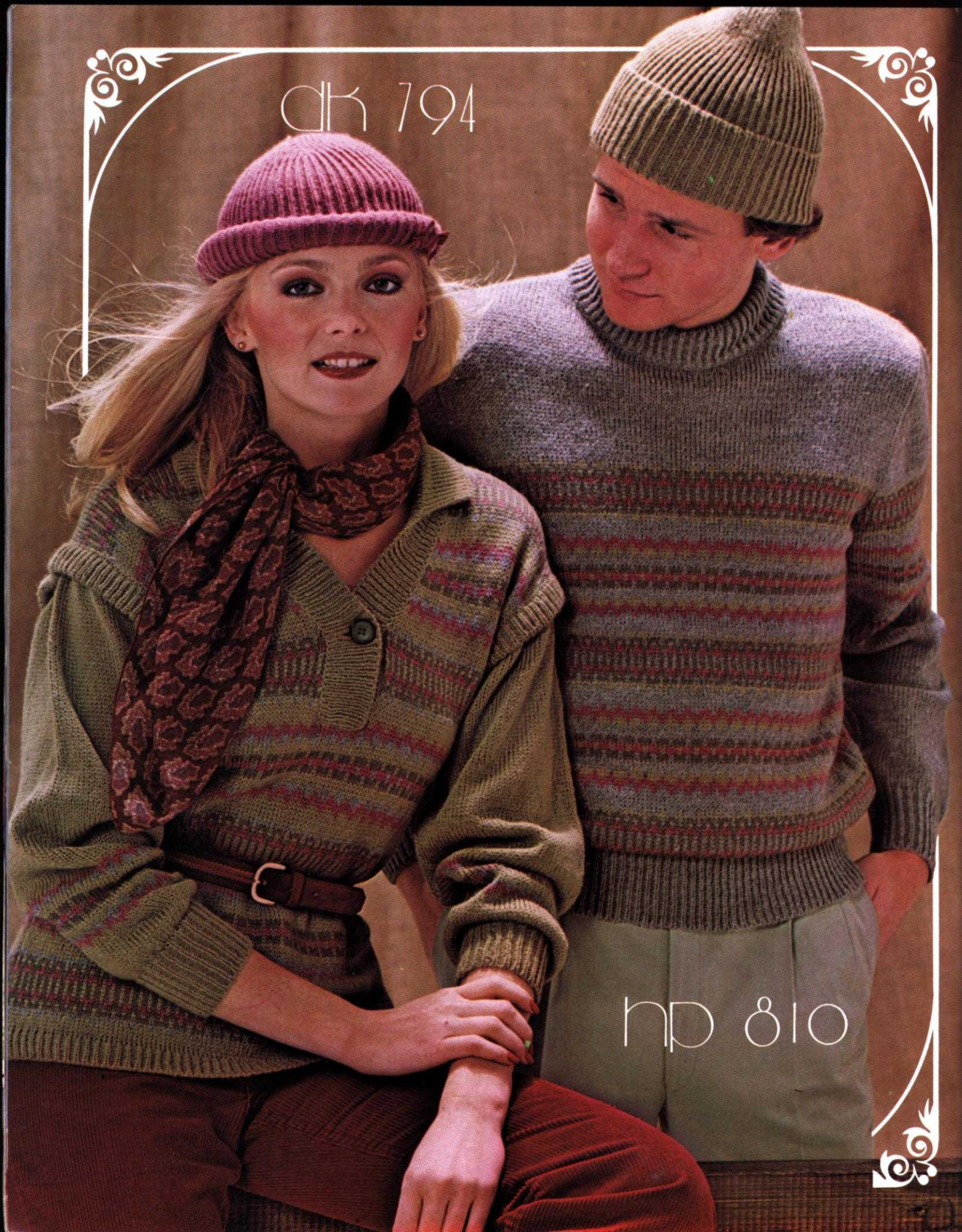

knitking

magazine

editorial

TABLE OF CONTENTS

PAGE NO.

KK 791	Child's Pullover	14
HP 792	Man's Jacket	15
HP 793	Man's Pullover	16
DK 794	Woman's Pullover	17
DK 795	Woman's Pullover	18
KK 796	Child's Jacket	19
HP 797	Man's Pullover	20
DK 798	Woman's Pullover & Beret	21
KK 799	Child's 2-piece Suit	22
KK 800	Child's 3-piece Suit	23
DK 801	Woman's Jacket	25
KK 802	Baby's Pullover	26
DK 803	Woman's Cardigan Sweater	26
DK 804	Woman's Vest	28
HP 805	Man's Pullover	29
DK 806	Woman's 3-piece Evening Suit	30
DK 807	Woman's Jacket	31
DK 808	Woman's Pullover & Cap	32
DK 809	Woman's Vest & Cardigan	33
HP 810	Man's Pullover	36
DK 811	Woman's Dress & Pants	37
DK 812	Woman's Dress & Tunic	38
DK 813	Woman's Jacket & Skirt	41

During our visit to Japan in October last, my wife and I made a whirlwind tour to the offices and factories of our main suppliers... The hospitality afforded us every step of the way was beyond anything we have experienced in any other country of the world and we thank our friends at Juki who manufacture our BABY LOCK sewing machines... at Belna who make our BELLINKY seaming machines... at Corona who make our JUMBO machines and at BROTHER INDUSTRIES where we saw KH 840 knitting machines actually being assembled and pouring off the assembly line one complete (packed for shipping) machine every few minutes.

BROTHER INDUSTRIES occupies an area covering several city blocks in Nagoya and we were tremendously impressed with the excellent working conditions... the extreme efficiency of their entire operation... the obvious skills, speed and 'happy in the job' atmosphere given out by the line workers.. When our mechanics in Los Angeles service a machine, it takes up to 20 minutes to replace 200 needles... the worker on the line at BROTHER displayed the skill and dexterity of a magician as she fanned out (in groups of 40) 200 needles and dropped them precisely into their machine slots in less than 20 seconds...! Each machine is checked several times as it travels on a conveyor belt from one assembler to another and every machine is knitted on twice with actual yarn to check the accuracy of punch cards and lacemakers.

It was interesting to note that every garment made in BROTHER INDUSTRIES garment design workshop is always drawn first on a Knitleader Chart... and that a Knitleader is considered a most essential part of every BROTHER machine sold in Japan... in fact, every knitting machine school and teaching center starts instruction with the Knitleader... so .. if you have a neglected Knitleader, take a tip from the experts and start using it now. You will wonder how you ever knitted without it.

The knitting machine research and development department at BROTHER INDUSTRIES is a top secret area... not open to any visitors, but we talked with the head man there and we can promise you... some sensational developments can be expected in the future.

Publisher: KNITKING CORPORATION, 1128 Crenshaw Blvd., Los Angeles, Calif. 90019. Telephone: (213) 938-2079. Published bi-monthly. Subscriptions: USA — \$15.00 annually, single copies \$4.00; Canada — \$18.00; other parts of the world — \$20.00. The entire contents of KNITKING MAGAZINE are copyright and must not be reproduced in any shape or form without the express permission, in writing of the publisher. © COPYRIGHT 1979 by KNITKING CORPORATION.

General Instructions

HOW TO READ THE CHARTS AND INSTRUCTIONS

There are 3 sizes given for each Pattern in KNITTING MAGAZINE. Above each Chart for the different sizes, you will see that the first and smaller sizes might be shown as 8/10, the second size as (12/14) and the third as [16/18]. Check the measurements at the bustline and hips on the Charts to be certain that you will knit the correct size, remembering these are ACTUAL measurements of the completed section and that there must be a bigger allowance at the bustline and hipline for a Jacket or a Coat than there would be for a fitted dress or a fitted blouse or pullover. The question in your mind should be "How do I want this garment to fit...?"

When you have chosen the size you need, you can follow the Charts as shown. You will notice that where the shapings are the same FOR ALL SIZES, only 1 set of shapings will be shown on the first Chart and if you are knitting the 2nd or 3rd size, you simply follow the shapings as given for the first size. If the shapings are different, this will be shown on the Charts and you should follow them as given.

On the Charts, increases and decreases will be shown as follows

5x1

[6] The number in the box means number of ROWS between the shapings, while the 5x1 above the box means - 1 st. 5x... so you will increase or decrease 1 st. every 6th row 5x.

ARMHOLE SHAPINGS - NECK SHAPINGS - SHOULDER SHAPINGS - are made on every 2nd row UNLESS there is a number in a box along side or below the shapings. The rule is... where there is no box with a number, the shaping is made on every 2nd row.

THE PRINTED INSTRUCTIONS

You can follow the printed instructions or use them in combination with the Charts. Where there is any question in the printed instructions, you have the Charts to show you how the section will look.

The 3 sizes, with the different amounts of cast on stitches and the different shapings will look like this...

Cast on 124 (136) [148] sts. You will
Cast on 124 sts. for the first size.
Cast on 136 sts. for the 2nd size.
Cast on 148 sts. for the 3rd size.

The important thing to remember is that you MUST READ AHEAD so that you KNOW what to do for the size you are knitting. Sometimes where the number of stitches are the same but the number of times different, you will find shapings like this...
3 sts. 1x (2x) [3x], 2 sts. 1x (2x) [3x], 1 st. 3x (4x) [5x].
As you see, you MUST read ahead in order to follow the instructions as given for YOUR SIZE. The rows will be different for the different sizes in some cases... Shoulder and Neck shapings usually are worked at the SAME TIME for the back section - so watch for the words AT THE SAME TIME.

HOLDING STITCHES ON THE LEFT SIDE WHILE SHAPING THE RIGHT SIDE

When knitting a section of garment in stockinette stitch, it is easy to hold the stitches on the left side while knitting the right half, but when knitting a Pattern Stitch such as a Norwegian Design, a Holding Position Design, Weaving, etc., you should use the following method. For the NECK SHAPING, we tell you to bind off the center sts., put the needles on the left into holding position and complete the right half first... so with a strand of contrast yarn, knit ALL of the left side stitches manually by hand, pulling each stitch back against the needle bed to the OUT OF WORK position. When the right side is completed, carefully pull the stitches held on contrast, forward into working position and as you do so, undo the contrast yarn, line up the needles (KNITTING AM 3 machine owners, put the stitches under the sinkers) and complete the left half.

If you own a Japanese machine, you may find that when knitting the right half with the left side held in this way, the sinker plate will mark the left side while you are knitting the right half. To prevent this marking, you can tape a piece of paper over the knitting, underneath the sinkers, or if you own a Reversing Bar, you can hang this onto the Sinkers while you are knitting the right half. When hanging the Reversing Bar, be sure the eyes of the bar go BETWEEN the Sinker Posts on the upper part of the bar so that the tips of the bar only - show above the needle bed.

FULL FASHION DECREASING OR INCREASING

For Stockinette stitch, always use the Full Fashion method for increasing or decreasing.

TO DECREASE: Hang the 3rd stitch onto the 2nd stitch then move the stitches in to fill the empty needle.

TO INCREASE: Move the 2 end stitches 1 needle outward, then pick up the 3rd stitch from the row below and hang it onto the empty needle.

FINISHING: Block all sections. For PULLOVERS, JACKETS, and DRESSES: Join front to back at sides and shoulders. Sew sleeves together and set in. Hem lower edge and sleeve edges if needed. For a double neckband or armhole band, sew 1 edge to the inside and 1 to the outside of neck or armhole. For a single ribbed band, sew 1 edge to the outside of neck or armhole edge. For a cardigan or jacket with buttonholes, finish buttonholes and sew on buttons.

PANTS: Join front to back at sides. Sew inside leg seams, then join center front and back. Make hem at waistline and insert elastic. Hem lower edge of pants legs.

THE SAMPLE SWATCH

Before you begin to knit any garment, you will need to knit a sample piece using the yarn you have chosen for your garment, so that you can check the stitch and row gauge which must measure the correct number of stitches and rows in 5 cm (2 inches).

For each Pattern in KNITTING MAGAZINE, we give you 3 tension numbers to work from and if you use the specified yarn for the garment, you should be able to get the correct stitch and row gauge using one of these numbers. Here is a very easy way to make your sample swatch and count the stitches and rows without actually counting, by using our KNITTING Converta Tape.

Supposing the Tension Numbers for the Stitch and Row Gauge are given as 5 to 7. Set the Tension Dial to the first number which is 5. With contrast waste yarn, and using the quick cast on method, cast on 60 stitches and knit 10 rows. Change to garment yarn and turn the Row Counter to 0. Knit 30 rows. Counting from each end, knit the 10th stitch on each side by hand with a small piece of contrast yarn. Leave the needles in working position and knit 30 rows (Row 60), then knit 4 rows with contrast waste yarn. Turn the Row Counter to 0 and the Tension Dial to 6 and with garment yarn, knit 30 rows. Mark the 10th stitch on each side as you did before, knit 30 rows, then 4 rows with contrast waste yarn. Turn the Row Counter to 0 and with Tension 7, repeat the above once more, ending with 10 rows of contrast waste yarn. Remove the work from the machine by passing the Slide across the needles without yarn (sometimes called 'dropping').

Pull and stretch the sample piece both lengthwise and diagonally from corner to corner, then lengthwise again. Do not count the stitches and rows immediately, but allow the sample to rest for several hours or even over night. This will allow the stitches and rows to return to their basic form.

When your sample has rested and you are ready to count the stitches and rows, the KNITTING CONVERTA TAPE will do the counting for you without any counting on your part. Use the Tape as follows:

Measure the stitches with the TAPE, BETWEEN the 40 stitches marked with contrast waste yarn. Push the SLIDE so that the LEFT EDGE lines up to this exact measurement. Now look down along side the SLIDE and find the number 40 on the TAPE. The number directly opposite on the SLIDE will be your Stitch Gauge to 5 cm (2"). To find the number of rows in 5 cm (2"), place the TAPE to measure over the 60 rows, push the SLIDE to this number with the left edge lined up, the look for the number 60 on the TAPE and directly opposite this will be the number of rows to 5 cm (2")

If you do not own a KNITTING CONVERTA TAPE, you must mark a 5 cm (2 inch) square in the center of the knitting, then count the number of stitches and rows within the square.

Pattern Symbols

Knitting – Chart Symbols

- Size Symbols
(2nd Size)
< > 3rd Size
① Color Number
- Cast on
Stitch
Row
Hem
Bind off
- Stockinette stitch – worn on the Knit side.
Stockinette stitch – worn on the Purl side.
Knit 1, Purl 1 Ribbing
Ribbing Pattern – worn on the Knit side.
Ribbing Pattern – worn on the Purl side.
- Closed Dart
Open Dart
Put on a stitch holder
Reverse 1 section
On every other needle
Number of Rows between Shapings. Make increase (or decrease) FIRST, then knit 4 rows. For example: 3 x 1  means decrease (or increase) 1 st., knit 4 rows; decrease 1 st., knit 4 rows; decrease 1 st., knit 4 rows; decrease 1 st., knit 4 rows. All decreasing (or increasing) without row numbers as shown must be shaped on every 2nd row.

 Increase

 Increase 2 sts. With a transfer tool, move the sts. over the left (or right) leaving 2 empty needles at the point of increase. At the increase point, move 1 st. to the left, (or right) so that there is an empty needles on each side of a stitch. On each side of the center stitch, pick up a stitch from the row below and hang it onto the empty needle.

 3 stitches on 1 needle. The 1st and 3rd stitch in a group of 3 has been hung on the 2nd or center needle.

 Short Row increase or decrease; for instance on a flared skirt knitted sideways.

 Pattern Stitch





 Pattern Stitch – worn on the Knit side.

 Pattern Stitch – worn on the Purl side.









 Repeat

- I = Front
- II = Back
- III = Sleeve
- IV = Skirt Front
- V = Skirt Back
- VI = Collar
- VII = Pocket
- VIII = Band
- IX = Belt
- X = Cuff
- XI = Pants Front
- XII = Pants Back

Finishing – Chart Symbols

-  Match numbers on section for assembling.
 Ease
 Fold Line
 Turn to the wrong side and hem.

Stitch Symbols

-  Needles in holding position
 Needles back into working position.
 Empty needle (leave in working position)
 Needle not used (in the out of work position).
 Two stitches on 1 needle, either transferred from the right side or the left side, then put into holding position.
 Needle holding 2 stitches. Stitch has been transferred from the RIGHT.
 Needle holding 2 stitches. Stitch has been transferred from the LEFT.
 Center of garment section



KK 791

CHILD'S PULLOVER

SIZES: 8/10 (12/14)
 YARN: Sport Weight
 GRAMS: color 2 100 150
 10 - 50 gram balls of different mixed colors (See picture).
 You can mix your own colors from left over yarns.
 TENSION: 7 to 10
 GAUGE: 12 sts. 16 rows = 5 cm (2")

Stockinette stitch with color stripes according to Chart. Bands and Collar are K2, P2 Ribbing.

FINISHING: See General Instructions.

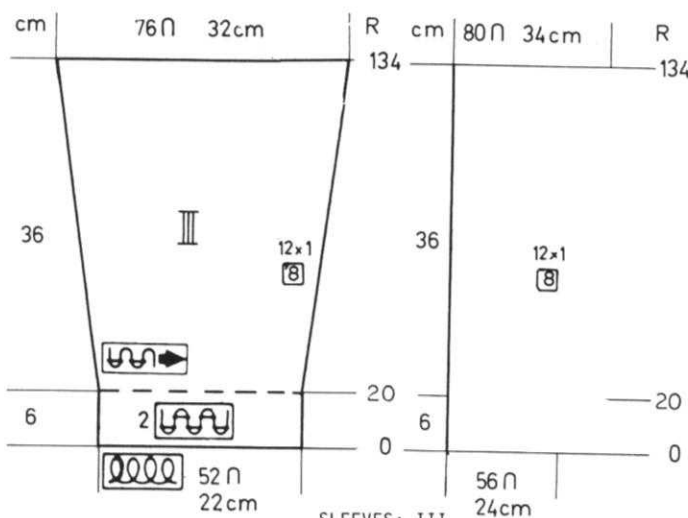
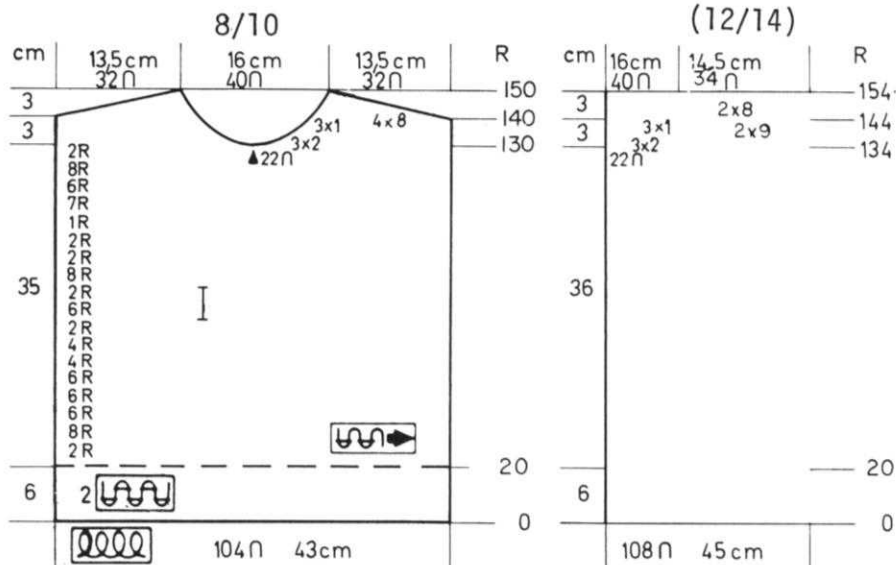

FRONT: I

Cast on 104 (108) sts. with color 2 and work 20 rows Ribbing. Continue in Stockinette stitch with color stripes as shown on the Chart. After Row 130 (134), bind off the center 22 sts., put the needles on the left into holding position and complete the right side first.
 *ON NECK SIDE, bind off 2 sts. 3x, 1 st. 3x for both sizes AND AT THE SAME TIME, after Row 140 (144) SHAPE SHOULDER: Bind off 8 sts. 4x. (9 sts. 2x, 8 sts. 2x). Bring the needles on the left into working position, knit 1 row to the left side, turn the Row Counter back to 130 (134) and complete the left half (watch stripes). Follow the instructions from *.

SLEEVES: III

Cast on 52 (56) sts. with color 2 and work 20 rows Ribbing. Continue in Stockinette stitch with color stripes same as front and back.
 ON EACH SIDE, increase 1 st. every 8th row 12x for both sizes. After Row 134, bind off.

BACK: II

Work the back the same as the front to row 140 (144). Bind off the center 32 sts., put the needles on the left into holding position and complete the right side first.
 *SHAPE SHOULDER AND NECK AT THE SAME TIME.
 FOR SHOULDER, bind off 8 sts. 4x, (9 sts. 2x, 8 sts. 2x),
 FOR NECK: bind off 1 st. 4x for both sizes.
 Bring the needles on the left into working position, knit 1 row to the left side, turn the Row Counter back to 140 (144) and complete the left half. Follow the instructions from *.

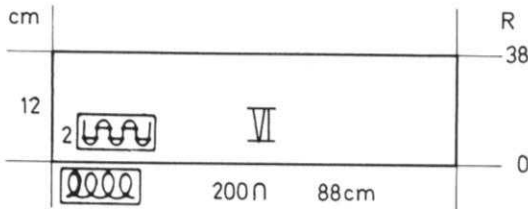

COLLAR: VI

Cast on 200 sts. with color 2 and work 38 rows Ribbing. Bind off.

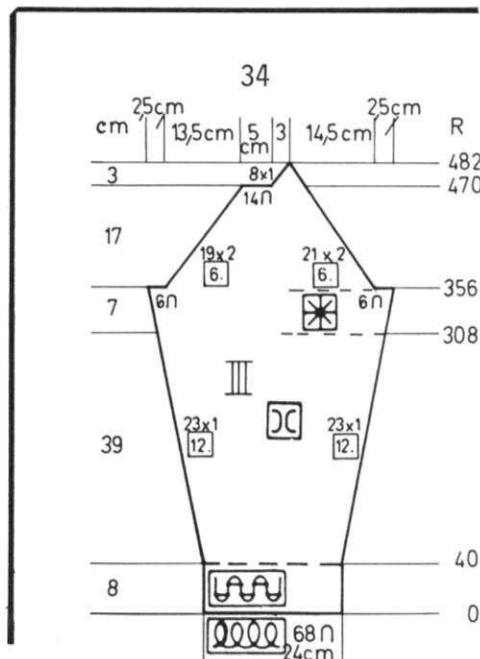
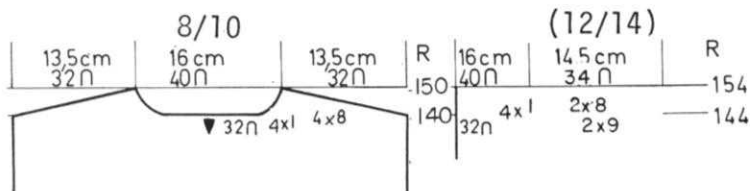

hp 792

MAN'S JACKET

SIZES: 34 (36) [38]
 YARN: Vienna
 GRAMS: 700 700 750
 TENSION: 5 to 7
 GAUGE: 14 sts. 34 rows = 5 cm (2")

English Rib and Racking Pattern of English Rib (2 pitch swing) See your Ribber Instruction Manual. Bands are K1, P1 Ribbing.

FINISHING: See General Instructions. Weave seams together from the right side, 1 st. in from edge. Lightly steam Collar and open sts., then sew to garment. Sew in a Jacket type Zipper, 1 st. in from edge.

NOTE: Work Full Fashion Decreases - move 3 edge sts. over 1 needle ON EACH BED (2 st. decrease).

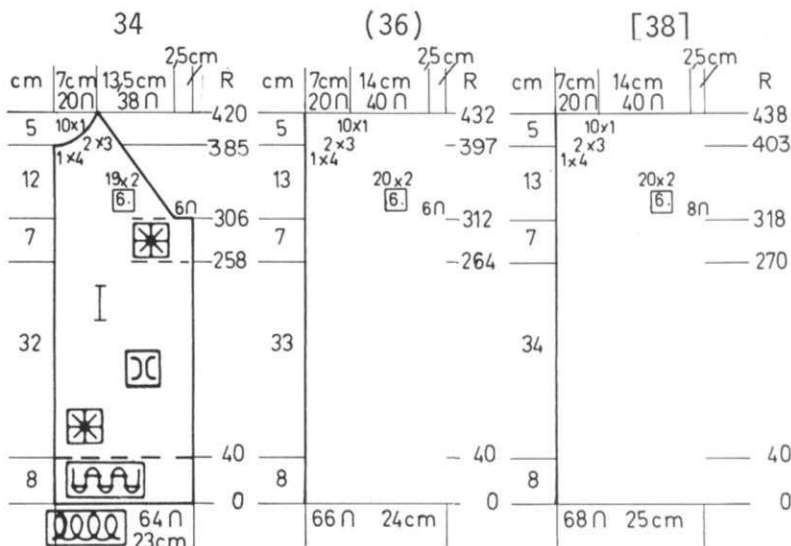

FRONT: I Make 1, reverse 1.

Cast on 64 (66) [68] sts. and work 40 rows K1, P1 Ribbing. Continue in English Rib Pattern to Row 258 (264) [270], then work the Racking Pattern to Row 306 (312) [318]. Continue English Rib. SHAPE RAGLAN: On Arm side, bind off 6 (6) [8] sts. then decrease 2 sts. every 6th row 19x (20x) [20x], but AT THE SAME TIME, after Row 385 (397) [403], SHAPE NECK: Bind off 4 sts. 1x, 3 sts. 2x, 1 st. 10x for all sizes.

COLLAR: VI

Cast on 192 (192) [196] sts. and work 50 rows K1, P1 Ribbing. Remove the sts. onto contrast waste yarn.

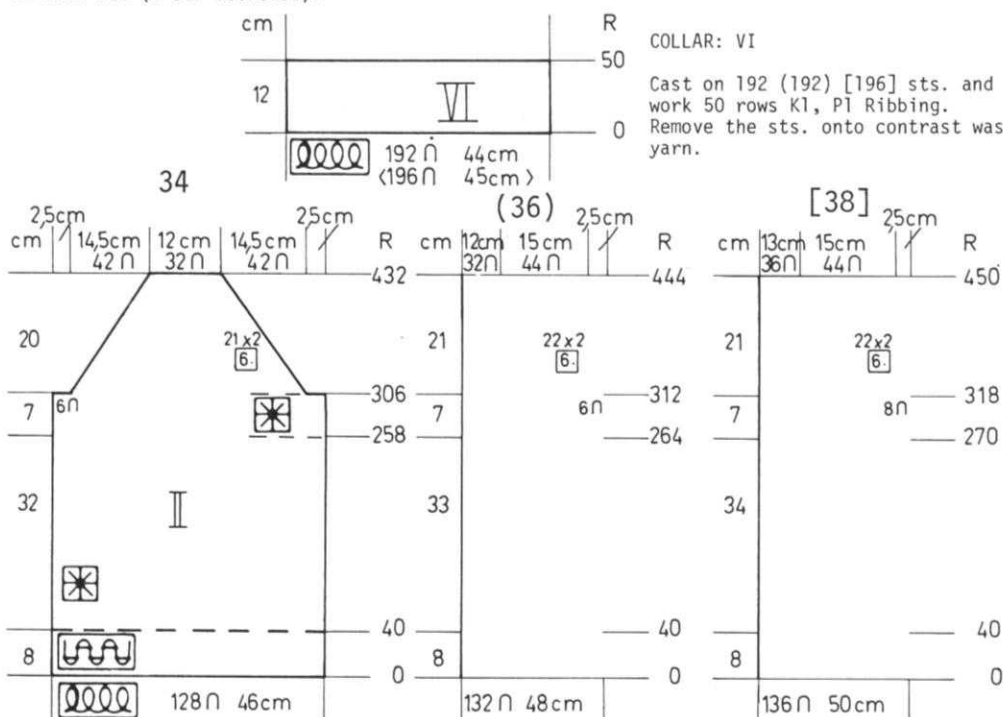

BACK: II

Cast on 128 (132) [136] sts. and work 40 rows K1, P1 Ribbing. Continue in English Rib Pattern to Row 258 (264) [270] then change to the Racking Pattern to Row 306 (312) [318]. Change back to the English Rib Pattern and SHAPE RAGLAN: ON EACH SIDE, bind off 6 (6) [8] sts. then decrease 2 sts. every 6th row 21x (22x) [22x]. After Row 432 (444) [450], bind off the remaining sts.

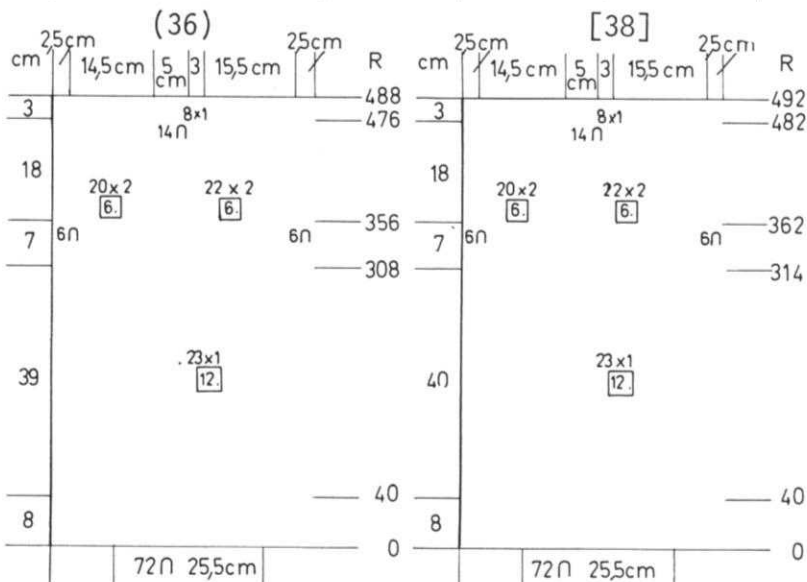

SLEEVES: III Make 1, reverse 1.

Cast on 68 (72) [72] sts. and work 40 rows K1, P1 Ribbing. Continue in English Rib Pattern and ON EACH SIDE, increase 1 st. every 12th row 23x for all sizes. After Row 308 (308) [314], work the Racking Pattern to Row 356 (356) [362]. Continue in the English Rib Pattern and SHAPE RAGLAN: ON EACH SIDE, bind off 6 sts. for all sizes, then decrease 2 sts. every 6th on RIGHT 21x (22x) [22x] and on the LEFT 19x (20x) [20x] and after Row 469 (475) [481], on the LEFT, bind off 14 sts. then decrease 1 st. every 2nd row 8x for all sizes. REVERSE the SHAPING for 2nd sleeve.

hp 793

MAN'S PULLOVER

SIZES: 38 (40) [42]
 YARN: KNITTING Acrylite
 GRAMS: Approx. 20 oz.
 TENSION: 2/2 for K1, P1 Ribbing
 4/4 for Pattern Stitch
 GAUGE: 20 sts. 30 rows = 5 cm (2") Pat.
 27 sts. 24 rows = 5 cm (2") Rib.

A Tuck Stitch using the Main Machine & Ribber. EVERY NEEDLE ON BOTH BEDS.
 Punch Your own Card.

FINISHING: See General Instructions.
 Sew on back Neckband, making sure the band starts where X is on front neck and ends at same place on other side of neck. Baste front insert to V then weave together, leaving 76 sts. free to hang - (see picture).

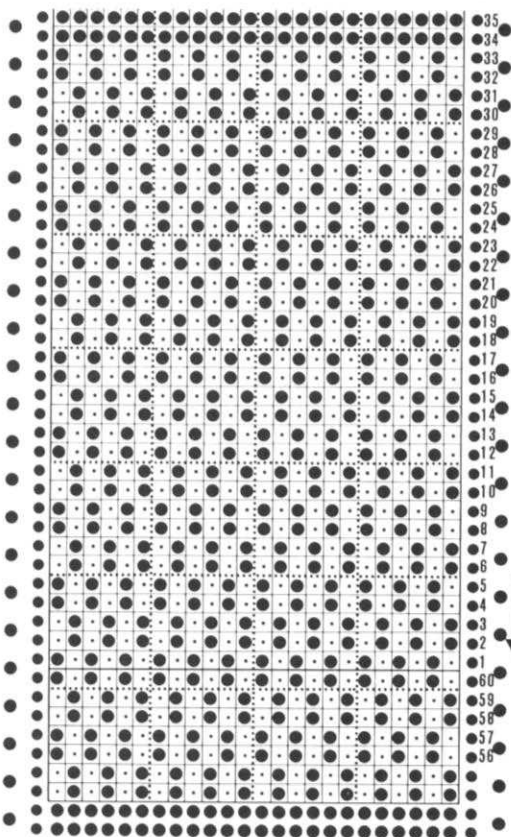
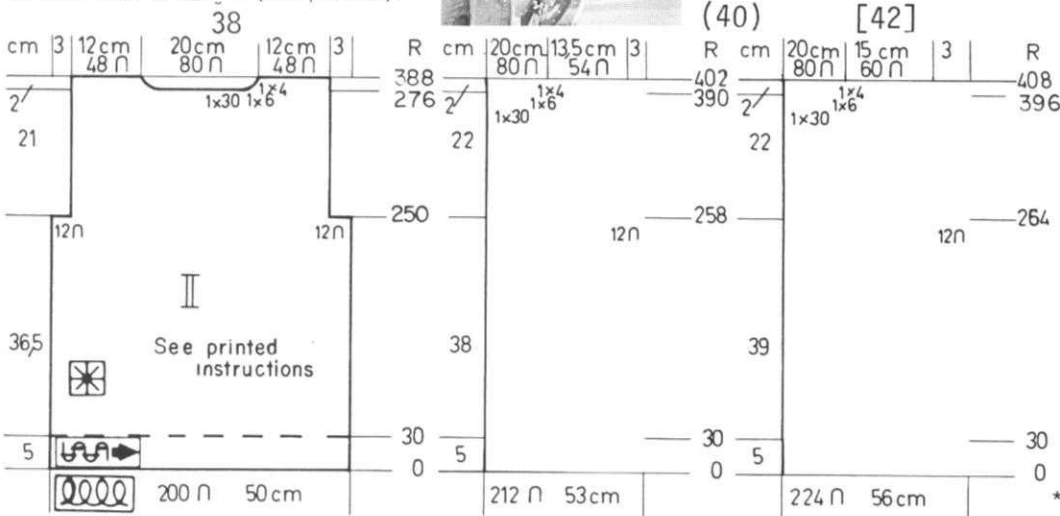
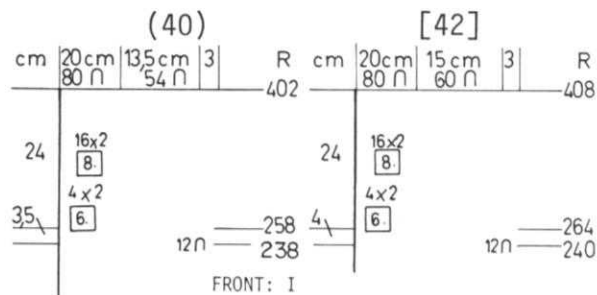
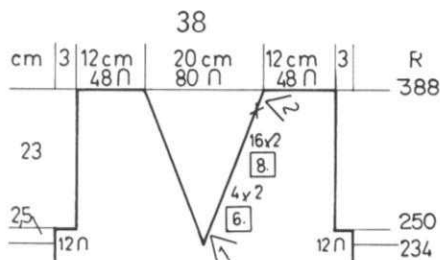

Work the front the same as the back to Row 234 (238) [240].
 Put half the sts. on the left into holding position and complete the right side first.

*AT NECK EDGE, decrease 2 sts. every 6th row 4x, every 8th row 16x - for all sizes.

AT THE SAME TIME, after Row 250 (258) [264], bind off 12 sts. for Armhole.

After Row 388 (402) [408], bind off the remaining sts.

Bring the needles on the left into working position, knit 1 row in Pattern to the left side, turn the Row Counter back to 234 (238) [240] and complete the left half. Follow the instructions from *.

BACK: II

Cast on 200 (212) [224] sts. with half the sts. on the main machine and half on the Ribber. (100) [106] [112] sts. on each bed.

Work 30 rows K1, P1 Ribbing, then continue in Pattern.

Knit to Row 250 (258) [264].

SHAPE ARMHOLE: ON EACH SIDE, bind off 12 sts.

Knit to Row 276 (390) [396].

Put half the sts. on the left into holding position and complete the right side first.

*ON NECK SIDE, bind off for all sizes, 30 sts. 1x, 6 sts. 1x, 4 sts. 1x. After Row 388 (402) [408], bind off the remaining sts.

Bring the needles on the left into working position, knit 1 row in Pattern to the left side, turn the Row Counter back to 276 (390) [396] and complete the left half. Follow the instructions from *.

SLEEVES: III

Cast on 112 (112) [120] sts.

56 (56) [60] st. on each bed.

Work 36 rows K1, P1 Ribbing

then continue in Pattern.

ON EACH SIDE, increase 1 st.

every 7th row 36x for all sizes.

After Row 318 (318) [324], bind off.

NECKBAND:

Cast on 220 sts. (110 on main machine, 110 on Ribber).

Tension 6/6 - 12 rows K1, P1

Ribbing with the last 3 rows with

Tension 10. Bind off using the

Latch Tool method.

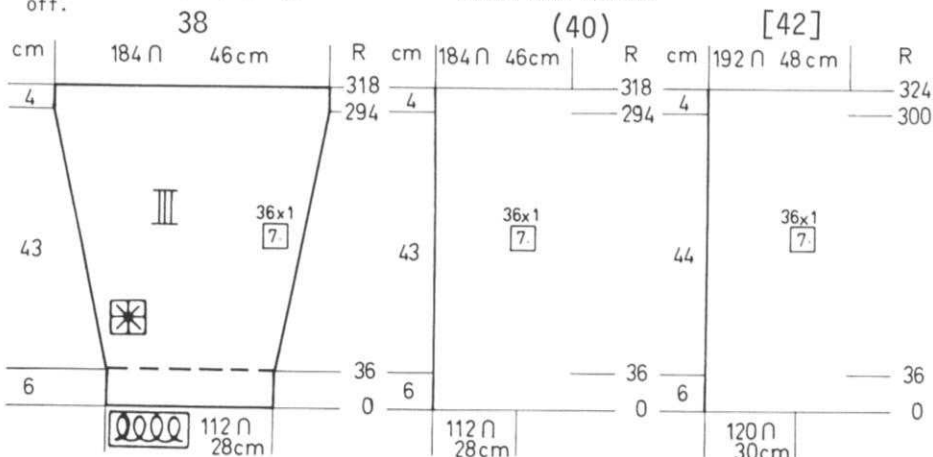

DK 794

WOMAN'S PULLOVER

SIZES: 10/12 (14)
YARN: Fortissima or Vienna
GRAMS:
 color 1 350 400
 color 2 100 100
 color 3 50 50
 color 4 50 50
TENSION: 5 to 6
GAUGE: 13 sts. 13 1/2 rows = 5 cm (2")

FINISHING: See General Instructions. Close Shoulder. Sew on Armbands and fold over to the inside. Sleeve is attached to the inside, leaving the Ribbing on top (see Picture). Sew bands and collar together then sew to neckline with 76 sts. on back and 76 sts. on each front opening with 32 sts. along straight edge. Sew band to the 10 bind off sts. at center with right over left.

A Norwegian Design on front, back and lower sleeves. Collar & Bands are K1, P1 Ribbing.

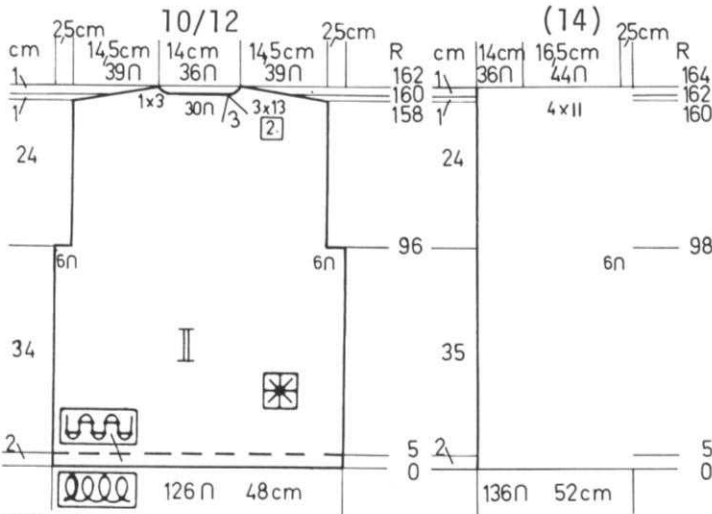

Cast on 126 (136) sts. and work 5 rows K1, P1 Ribbing. Continue in Pattern. Knit to Row 96 (98). **SHAPE ARMHOLE:** ON EACH SIDE, bind off 6 sts. for both sizes. Knit to Row 158 (160). **SHAPE SHOULDER and WATCH FOR NECK SHAPING.** FOR SHOULDER, ON EACH SIDE, bind off 13 sts. 3x, (11 sts. 4x), FOR NECK, after Row 160 (162), bind off the center 30 sts.

Put the needles on the left into holding position and complete the right side first. ***ON NECK SIDE,** bind off 3 sts. 1x, for both sizes. Bring the needles on the left into working position, knit 1 row in Pattern to the left side, turn the Row Counter back to 160 (162) and complete the left half. Follow the instructions from * and don't forget to complete the shoulder shaping.

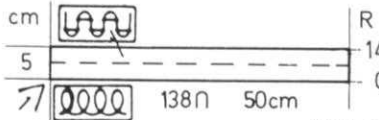

Cast on 138 sts. and work 14 rows Ribbing then bind off.

INSERT

Cast on 184 sts. (92 sts. on each bed). Work 12 rows K1, P1 Ribbing. **ON THE RIGHT,** bind off 76 sts. Then continue with Knit/Knit on both beds over the remaining 108 sts. **ON EVERY 4th ROW, ON EACH SIDE,** decrease 2 sts. 27x as follows: Hang the 2nd st. from Ribber, over 1 st., the 3rd st. from Machine over 1 st. The decreases will be on the 5th st. from edge. Insert should be completed after Row 126.

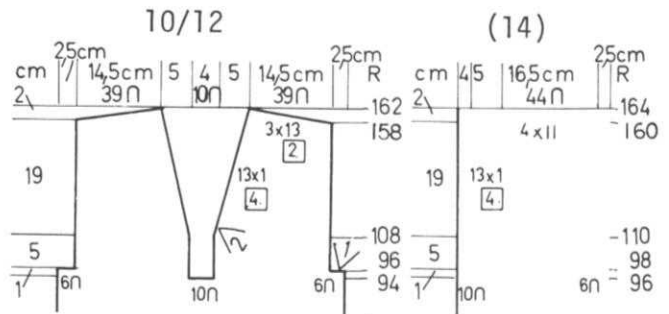
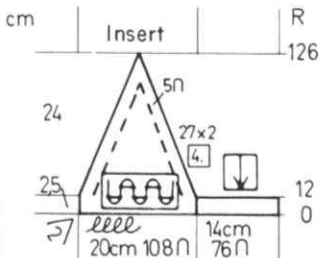

Work the front the same as the back to Row 94 (96). Bind off the center 10 sts., put the needles on the left into holding position and complete the right side first.

***After Row 96 (98),** bind off 6 sts. for armhole. After Row 108 (110), **ON NECK SIDE,** decrease 1 st. every 4th row 13x for both sizes and after Row 158 (160) **SHAPE SHOULDER** same as the back. Bring the needles on the left into working position, knit 1 row in Pattern to the left side, turn the Row Counter back to 94 (96) and complete the left half. Follow the instructions from *.

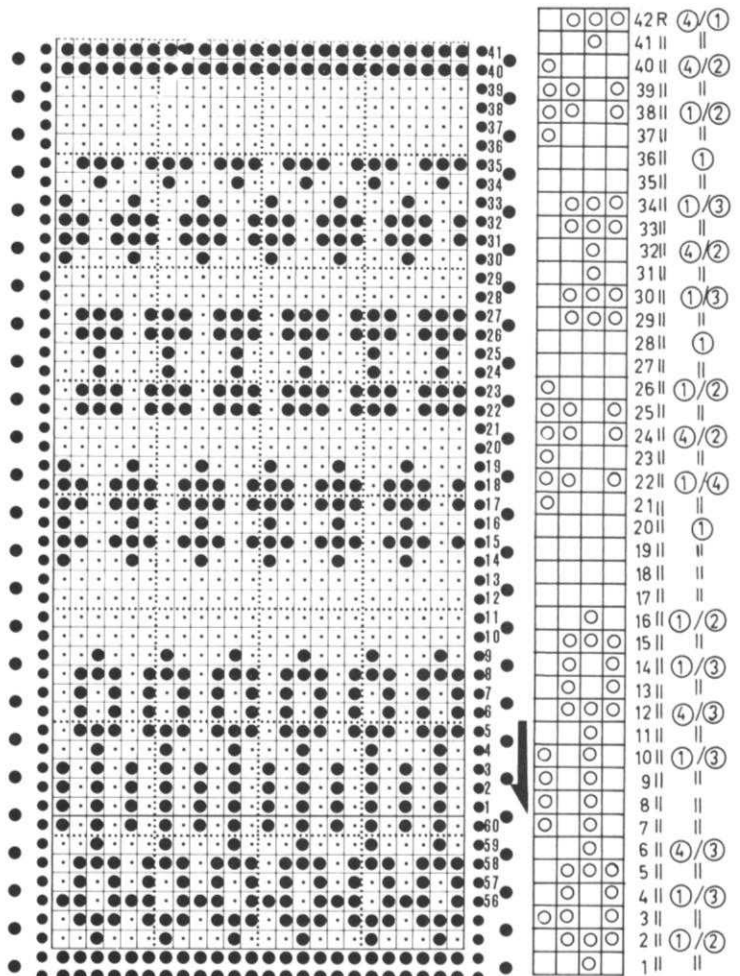

dk 794

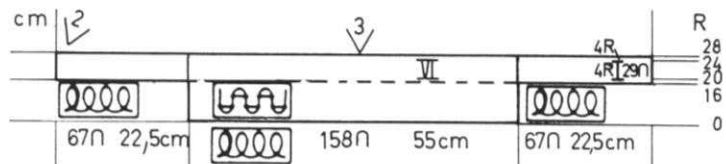
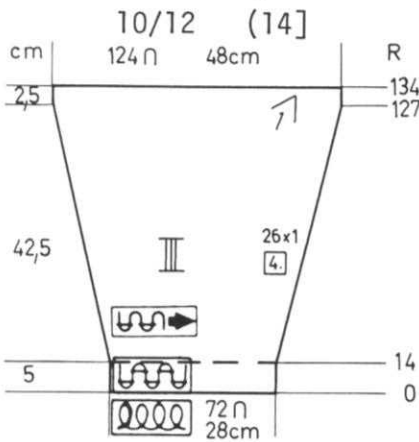

COLLAR & NECKBAND:

Cast on 158 sts and work 28 rows K1, P1 Ribbing. Bind off.

NECKBAND: Cast on 67 sts. Work 12 rows K1, P1 Ribbing. Bind off. Work a 2nd band in the same way, but make a BUTTONHOLE after Row 4, working 4 rows over 29 sts. on the right first, then 4 rows over the remaining sts. Bring all needles into work and complete the remaining 4 rows. Bind off. Make another band the same. Sew each piece to each side of Collar. See Picture.

SLEEVES: III

Cast on 72 sts. and work 14 rows K1, P1 Ribbing. Continue in Stockinette stitch to Row 30 - but AT THE SAME TIME, ON EACH SIDE, increase 1 st. every 4th row 26x. After Row 30, Continue in Pattern After Row 134, bind off.



dk 795

WOMAN'S PULLOVER

SIZES: 10/12 (14/16)
YARN: Micaela
GRAMS: 350 400
TENSION: 7 or 8
GAUGE: 10 sts. 23 rows = 5 cm (2")

A Tuck Stitch Pattern. Punch your own Card. The bands are K1, P1 Ribbing.

FINISHING: See General Instructions. Crochet around edges of Scarf.

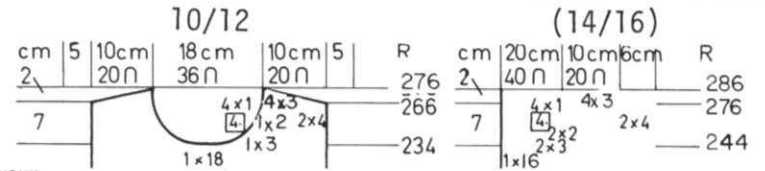

FRONT: I

Work the front the same as the back to Row 234.

Bind off the center 18 (16) sts. put the needles on the left into holding position and complete the right side first.

*ON NECK SIDE, bind off 3 sts. 1x, 2 sts. 1x, then every 4th row 1 st. 4x. (3 sts. 2x, 2 sts. 2x, then every 4th row 1 st. 4x). After Row 266 (276), SHAPE SHOULDER same as the back. Bring the needles on the left into working position, knit 1 row in Pattern to the left side, turn the Row Counter back to 234 (244) and complete the left half. Follow the instructions from *.

NECKBAND:

Cast on 144 sts. and work 8 rows Ribbing. Remove onto contrast waste yarn.

SCARF:

Cast on 49 sts. and work in Pattern for 660 rows (55 inches). Bind off.

BACK: II

Cast on 96 (104) sts. and work 36 rows Ribbing.

Continue in Pattern. Knit to Row 164 (174).

SHAPE ARMHOLE: ON EACH SIDE, bind off 10 (12) sts.

Knit to Row 266 (276)

Bind off the center 24 (28) sts. put the needles on the left into holding position and complete the right side first.

*SHAPE SHOULDER AND NECK AT THE SAME TIME.

FOR SHOULDER, bind off

4 sts. 2x, 3 sts. 4x for both sizes. FOR NECK, bind off 2 sts. 3x.

Bring the needles on the left into working position, knit 1 row in Pattern to the left side, turn the Row Counter back to 266 (276) and complete the left half. Follow the instructions from *.

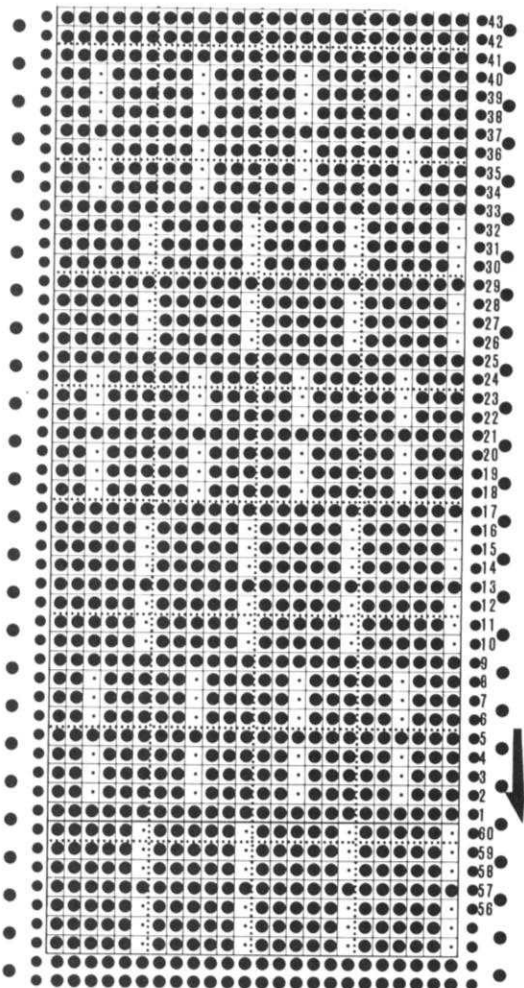
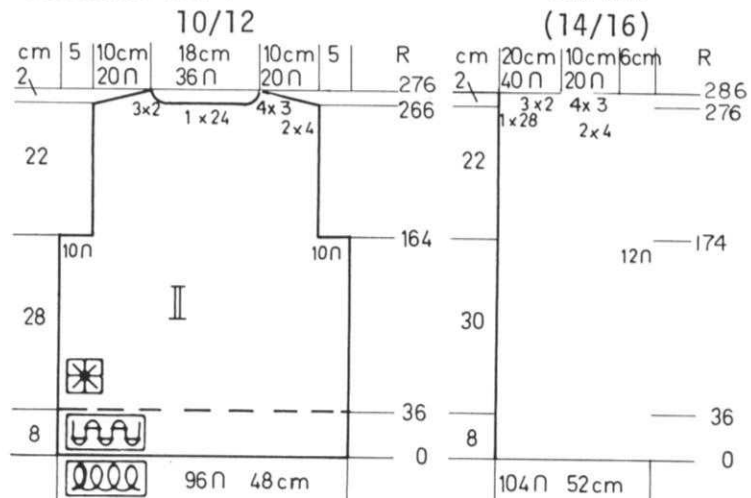

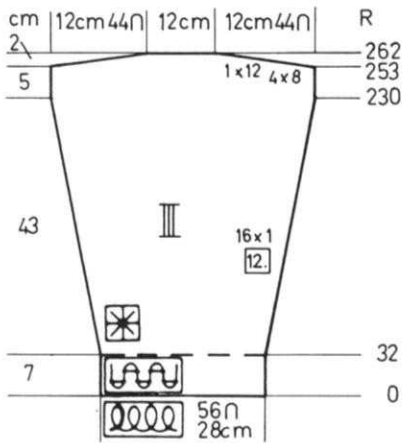

SLEEVES: III

Cast on 56 sts. and work 32 rows Ribbing.
Continue in Pattern and ON EACH SIDE, increase 1 st. every 12th row 16x.
After Row 252, SHAPE CAP: ON EACH SIDE, bind off 6 sts. 4x, 12 sts. 1x.
After Row 262, bind off the remaining sts.

KK 796

CHILD'S JACKET

SIZES: 2 (4) [6]
YARN: Euro Sport plus thin yarn in another color worked together.
GRAMS: 300 300 350
TENSION: 9 or 10
GAUGE: 11 sts. 13 rows = 5 cm (2")

Knit 1, Purl 1 Ribbing using EVERY 3rd NEEDLE ON EACH BED. Work CABLES after Every 6th row on the Main Machine only. Hang the 1st st. on 2nd, the 3rd on 4th, etc.



FINISHING: See General Instructions. Work 2 rows single crochet around all edges, making BUTTONHOLES on 2nd row down the right front. For Buttonholes, chain 3, skip 2 placing the buttonholes evenly spaced. Work 1 more row crochet around edges as follows:
*ch 3, slip st. into first ch, skip 1 st. then REPEAT from * around.

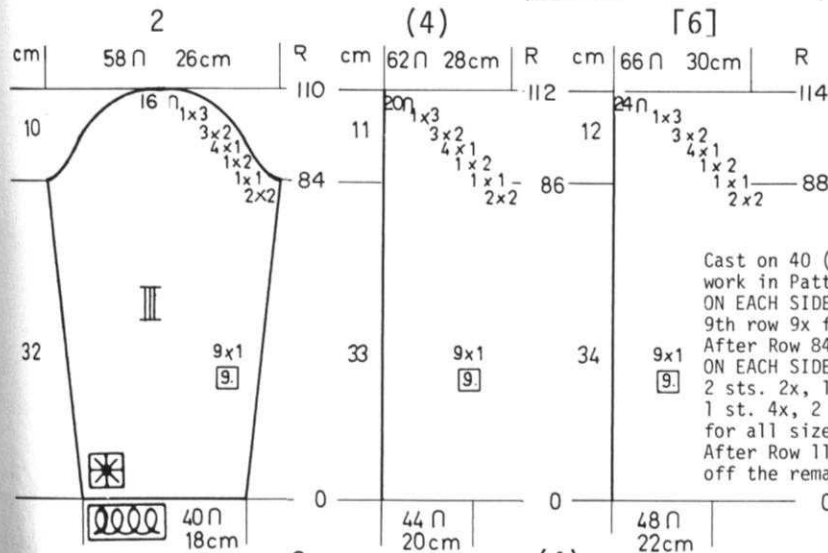
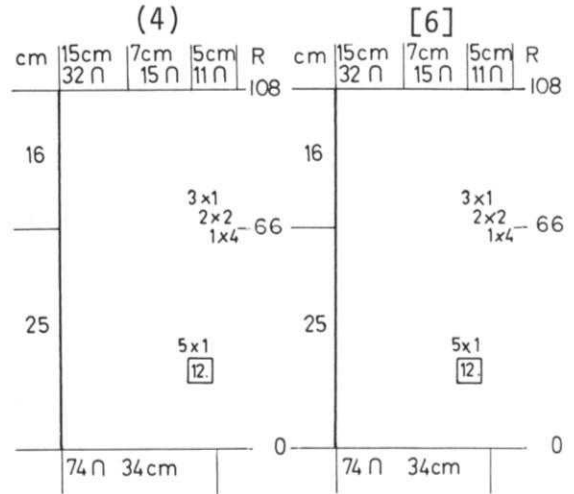
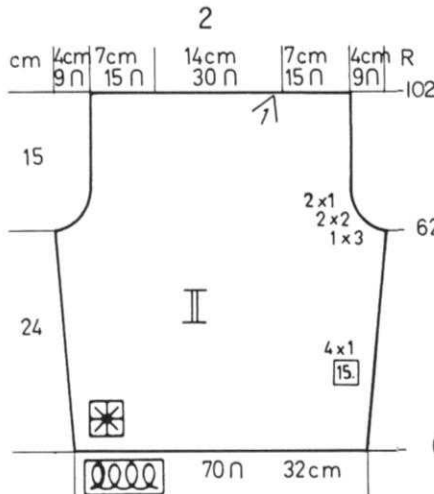

BACK: II

Cast on 70 (74) [74] sts. and work in Pattern (see explanation above Finishing). You should have 35 (37) [37] sts. on each bed. ON EACH SIDE, increase 1 st. every 15th row 4x. (every 12th row 5x). [every 12th row 5x].
After Row 62 (66) [66], SHAPE ARMHOLE: ON EACH SIDE, bind off 3 sts. 1x, 2 sts. 2x, 1 st. 2x. (4 sts. 1x, 2 sts. 2x, 1 st. 3x). [4 sts. 1x, 2 sts. 2x, 1 st. 3x].
Knit to Row 102 (108) [108]. Bind off.

SLEEVES: III

Cast on 40 (44) [48] sts. and work in Pattern. (Half on each bed). ON EACH SIDE increase 1 st. every 9th row 9x for all sizes.
After Row 84 (86) [88], SHAPE CAP: ON EACH SIDE, bind off 2 sts. 2x, 1 st. 1x, 2 sts. 1x, 1 st. 4x, 2 sts. 3x, 3 sts. 1x for all sizes.
After Row 110 (112) [114], bind off the remaining sts.

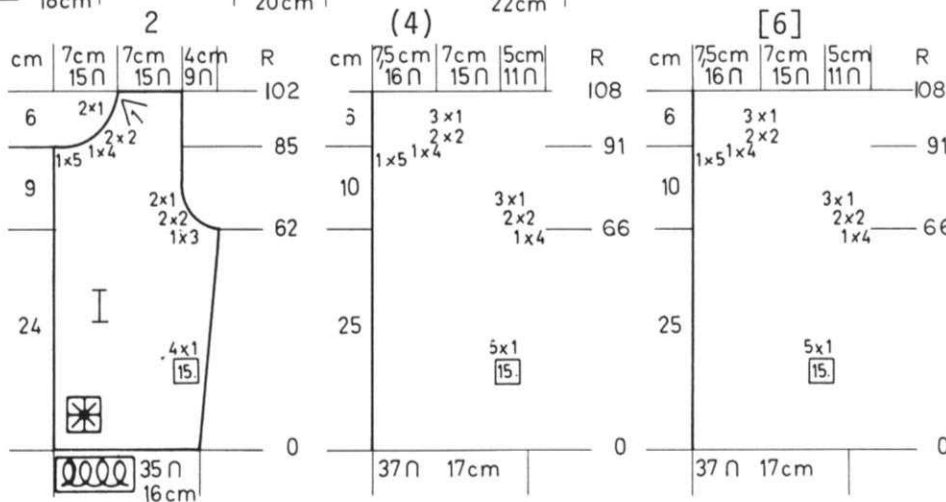

FRONT: I Make 1, reverse 1.

Cast on 35 (37) [37] sts. and work in Pattern (half the sts. on each bed). ON SIDE EDGE, increase 1 st. every 15th row 4x for all sizes.
After Row 62 (66) [66], SHAPE ARMHOLE: Bind off 3 sts. 1x, 2 sts. 2x, 1 st. 2x. (4 sts. 1x, 2 sts. 2x, 1 st. 3x). [4 sts. 1x, 2 sts. 2x, 1 st. 3x].
After Row 85 (91) [91], SHAPE NECK: Bind off 5 sts. 1x, 4 sts. 1x, 2 sts. 2x, 1 st. 2x. (5 sts. 1x, 4 sts. 1x, 2 sts. 2x, 1 st. 3x).
[Same as 2nd size].
After Row 102 (108) [108], bind off the remaining sts.

hp 797

MAN'S PULLOVER

SIZES: 38/40 (42)
 YARN: Knitting Worsted
 GRAMS:
 color 1 500 550
 color 2 100 100
 color 3 100 100
 color 4 50 50

TENSION: 10 OVER EVERY OTHER NEEDLE.
 GAUGE: 17 st. 13 rows = 10 cm (4")
 NEEDLES ARE COUNTED in the CHART INSTRUCTIONS.

Stockinette stitch with a Norwegian Border Design. Knitted over every other needle. The Bands are K2, P2 Ribbing and are knitted BY HAND with No. 5 Knitting Needles. Punch Card for the Norwegian border design.

FINISHING: See General Instructions. FOR NECKBAND, Pick up approximately 148 sts. around neckline with No. 5 Knitting needles. Work K2, P2 Ribbing for 7 cm (2 3/4"). Overlap band and sew in place (see Picture).

IMPORTANT: - Bring the required number of needles into working position then push back every other needle to the out of work position. THE EMPTY

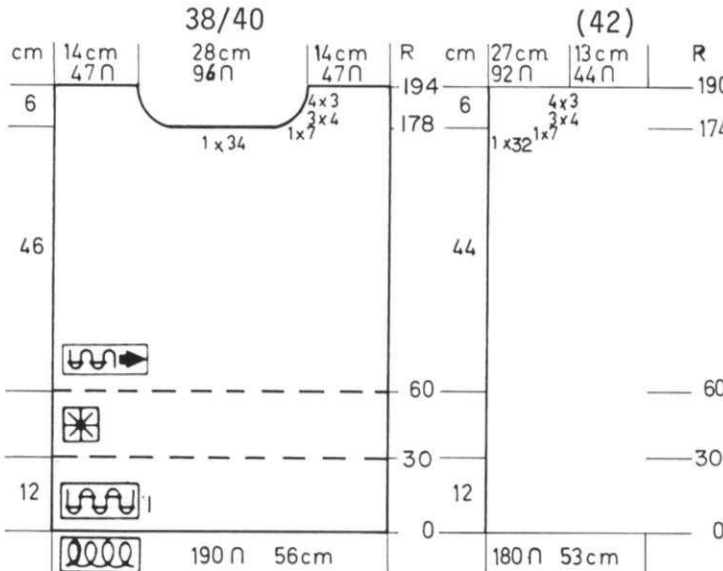
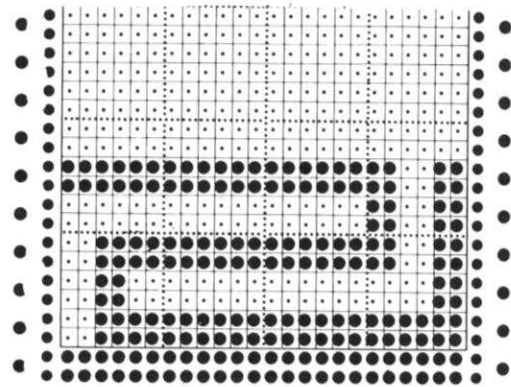

BACK: With hand knitting needles, (No.5) cast on 90 (95) sts. color 1. Work 30 rows K2, P2 Ribbing. Transfer to machine. Bring 180 (190) needles into working position, push every other needle back to the out of work position and hang the band onto the machine.
 Knit 1 row color 2, 1 row color 3, 1 row color 4. REVERSE WORK. Knit 2 rows color 2, then work the Norwegian Border Design. Knit 2 rows color 2.
 REVERSE WORK and knit 1 row color 4, 1 row color 3, 1 row color 2.
 REVERSE WORK. Continue in Stockinette stitch with color 1.
 After Row 174 (178), bind off the center 32 (34) sts. put the needles on the left into holding position and complete the right side first.
 ON NECK SIDE, bind off 7 sts. 1x, 4 sts. 3x, 3 sts. 4x for both sizes.
 After Row 190 (194), bind off the remaining sts.
 Bring the remaining needles into working position, knit 1 row to the left side, turn the Row Counter back to 174 (178) and complete the left half. Follow the instructions from *.

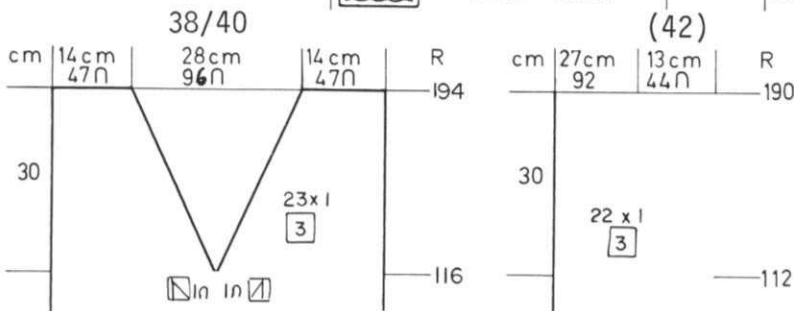

FRONT: I

Work the front the same as the back to Row 112 (116).
 Put half the sts. on the left into holding position and complete the right side first.
 *ON NECK SIDE, decrease 1 st. then every 3rd row, decrease 1 st. 22x (23x).
 After Row 190 (194), bind off the remaining sts.
 Bring the needles on the left into working position, knit 1 row to the left side, turn the Row Counter back to 112 (116) and complete the left half. Follow the instructions from *.

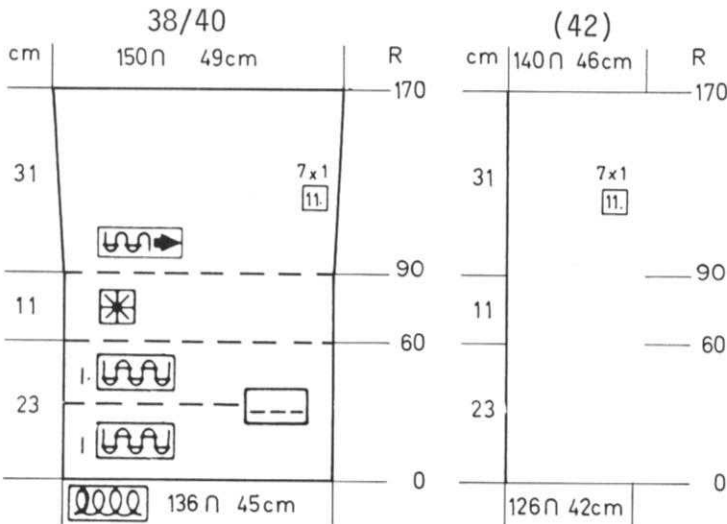

SLEEVES: III

Cast on 63 (68) sts. with color 1 and using hand knitting needles, work 60 rows K2, P2 Ribbing. Transfer the sts. to machine in the same way as you did for front and back. Bring 126 (136) needles into work then push every other needle back to the out of work position. Hang the sts. onto these needles and continue in Pattern following the instructions as for back and front.
 After Row 90, continue in Stockinette stitch.
 ON EACH SIDE, increase 1 st. every 11th row 7x for both sizes.
 After Row 170, bind off.



dk 798

WOMAN'S PULLOVER & BERET

SIZES: 10/12 (14/16)

YARN: Euro Sport

GRAMS:
 color 1 300 350
 color 2 100 100
 color 3 50 50
 color 4 50 50
 color 5 50 50

TENSION: 8 to 10

GAUGE: 10 sts. 14 rows = 5 cm (2")

Stockinette stitch with a Norwegian Design. Bands are K2, P2 Ribbing.

FINISHING: See General Instructions. Weave the hat sections together. FOR TRIM on Hat, cast on 8 sts. with color 1, knit 12 rows. Sew together and stuff then sew to top of hat (see picture).

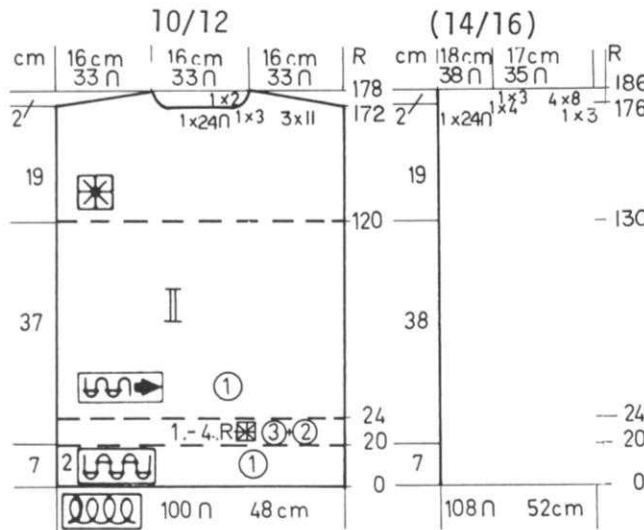

BACK: II

Cast on 100 (108) sts. with color 1 and work 20 rows Ribbing. Transfer the ribber sts. to main machine then work the 4 rows of Norwegian Design as shown. Continue in Stockinette stitch with color 1.

Knit to Row 120 (130).

Continue in the Norwegian Design.

Knit to Row 172 (176).

Bind off the center 24 sts., put the needles on the left into holding position and complete the right side first.

SHAPE SHOULDER AND NECK AT THE SAME TIME.

*FOR SHOULDER, bind off

11 sts. 3x.

(3 sts. 1x, 8 sts. 4x).

FOR NECK, bind off

3 sts. 1x, 2 sts. 1x.

(4 sts. 1x, 3 sts. 1x).

Bring the needles on the left into working position, knit 1 row in Pattern to the left side, turn the Row Counter back to 172 (176) and complete the left half. Follow the instructions from *.

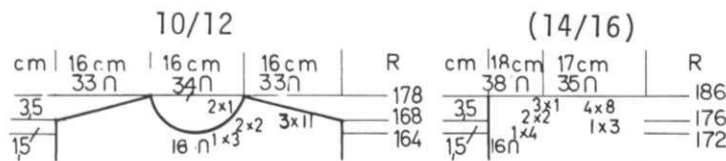

FRONT: I

Work the front the same as the back to Row 164 (172).

Bind off the center 16 sts., put the needles on the left into holding position and complete the right side first. WATCH FOR SHOULDER SHAPING.

*ON NECK SIDE, bind off

3 sts. 1x, 2 sts. 2x, 1 st. 2x.

(4 sts. 1x, 2 sts. 2x, 1 st. 3x).

AT THE SAME TIME, after Row 168 (176)

SHAPE SHOULDER same as the back.

Bring the needles on the left into working position, knit 1 row in Pattern to the left side, turn the Row Counter back to 164 (172) and complete the left half. Follow the instructions from *.

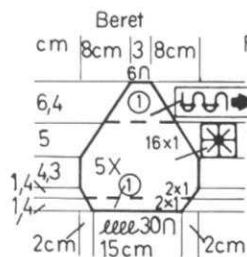

BERET: Make 5 sections.

Cast on 30 sts. with color 1 and work Stockinette st. increasing 1 st. ON EACH SIDE 2x.

After Row 4, continue in Pattern.

ON EACH SIDE, increase 1 st. 2x.

After Row 20, ON EACH SIDE, decrease 1 st. 16x BUT AT THE SAME TIME, after Row 34, continue in Stockinette stitch with color 1. After Row 52, bind off.

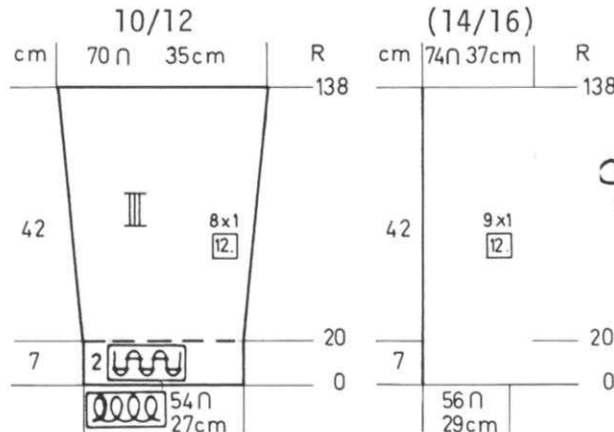
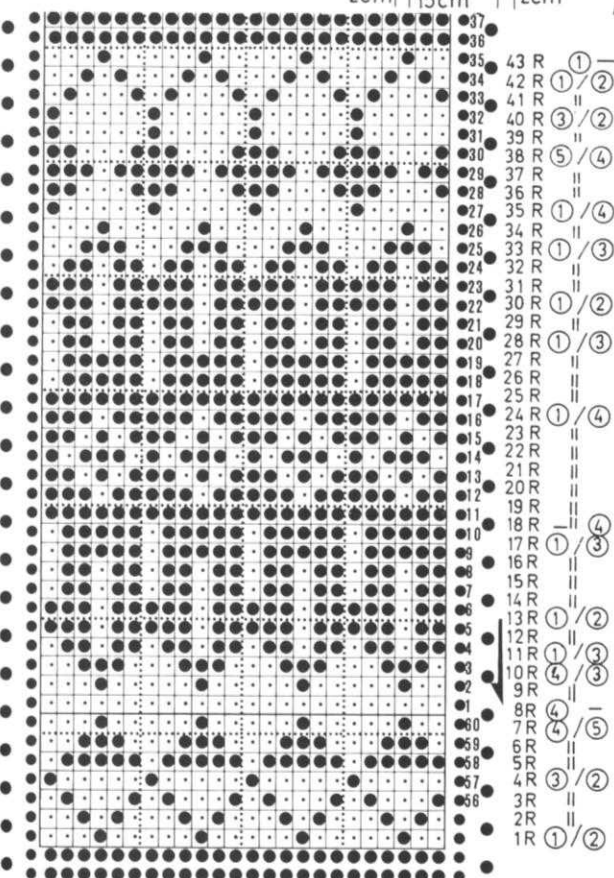

SLEEVES: III

Cast on 54 (56) sts. with color 1 and work 20 rows Ribbing. Transfer the ribber sts. then work the 4 rows of the Norwegian Design. Continue in Stockinette st. with color 1.

ON EACH SIDE, increase 1 st. every 12th row 8x (9x).

After Row 138, bind off.

NECKBAND:

Cast on 76 sts. with color 1 and work 20 rows Ribbing. Bind off or remove onto waste yarn.



KK 799

CHILD'S 2-PIECE SNOW SUIT

SIZE: 2/3
 YARN: Euro Sport - Background knitting.
 A loopy, fluffy yarn of your choice (not available from KNITKING) for WEAVING.

GRAMS: -
 color 1 400 - Euro Sport
 colors 2, 3, 4, - Check Charts and estimates of amounts when purchasing yarn.
 TENSION: 10
 GAUGE: 14 sts. 19 rows = 5 cm (2") (every other needle - empty needles ARE counted in stitch and row gauge.
 Elastic Thread, Zippers for front and legs on pants. #6 knitting needles for hand knitting the ribbed bands.

A Weaving Pattern. Punch your own Card and HAND FEED the weaving yarns. Every other needle is used for Pattern.

FINISHING: See General Instructions. Close all seams. Sew Hood together, then crochet onto neckline. Put in zippers on front and pants legs. With a running stitch, put in 4 rows of round elastic at waistline of pants.

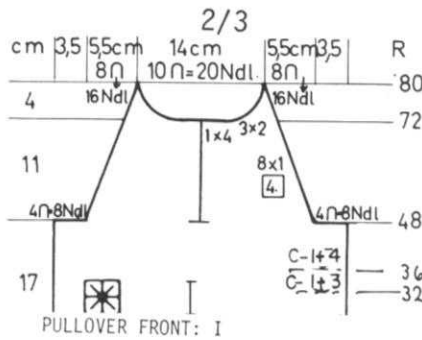

PULLOVER FRONT: I
 Work the front the same as the back to Row 48. Divide in the center and put the needles on the left into holding position and complete the right side first.

*SHAPE ARMHOLE SAME AS THE BACK, BUT AT THE SAME TIME, after Row 72, SHAPE NECK: Bind off 4 sts. 1x, 2 sts. 3x. Bring the needles on the left into working position, knit 1 row in Pattern to the left side, turn the Row Counter back to 48 and complete the left half. Follow the instructions from *.

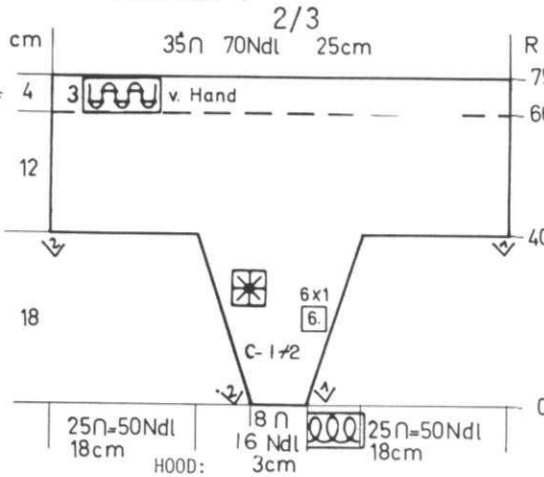

HOOD:
 Cast on 8 sts. over EVERY OTHER NEEDLE with color 1.
 Work in Weaving Pattern.
 ON EACH SIDE, increase 1 st. every 6th row 6x.
 After Row 40, ON EACH SIDE, cast on 25 actual sts. OVER EVERY OTHER NEEDLE. Continue in pattern to Row 66.
 Remove onto hand knitting needles and pick up a stitch in each stitch so that you have 70 sts.
 With color 1 work 9 rows K3, P3 Ribbing then bind off.

PANTS: XI / XII Make 2 sections.

With hand knitting needles and color 1, cast on 36 sts. and work K3, P3 Ribbing.
 ON EACH SIDE increase 1 st. every 6th row 3x.
 After Row 20, transfer the sts. to the machine with 2 sts. ON EACH NEEDLE (EVERY OTHER NEEDLE). 21 sts. Put Row Counter at 20.
 ON EACH SIDE, increase 1 st. every 8th row 7x.
 After Row 76, ON EACH SIDE, bind off 3 actual sts.
 Knit to Row 152, then remove the sts. onto hand knitting needles and increase 21 sts. EVENLY ACROSS. 50 sts. Work 10 rows K3, P3 Ribbing then bind off.

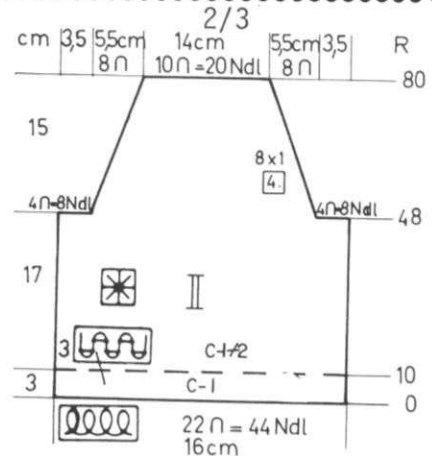
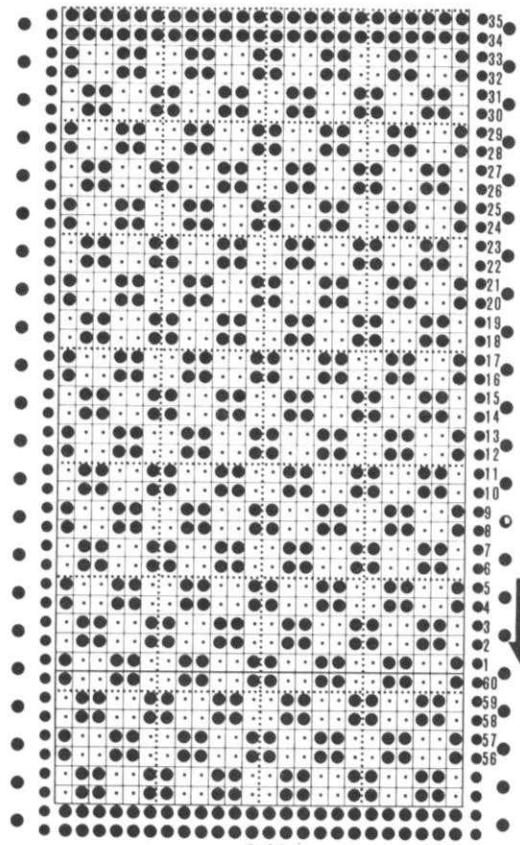

PULLOVER BACK: II

Cast on 44 sts. with hand knitting needles and color 1 and work 10 rows K3, P3 Ribbing.
 Transfer the sts. to machine placing 2 sts. on each needle (EVERY OTHER NEEDLE). 22 sts.
 Work the Weaving Pattern, changing the colors as shown on the front Chart.
 After Row 48, SHAPE ARMHOLE.
 ON EACH SIDE, bind off 4 actual sts.
 ON EACH SIDE, decrease 1 st. every 4th row 8x.
 After Row 80, bind off the remaining actual 10 sts.

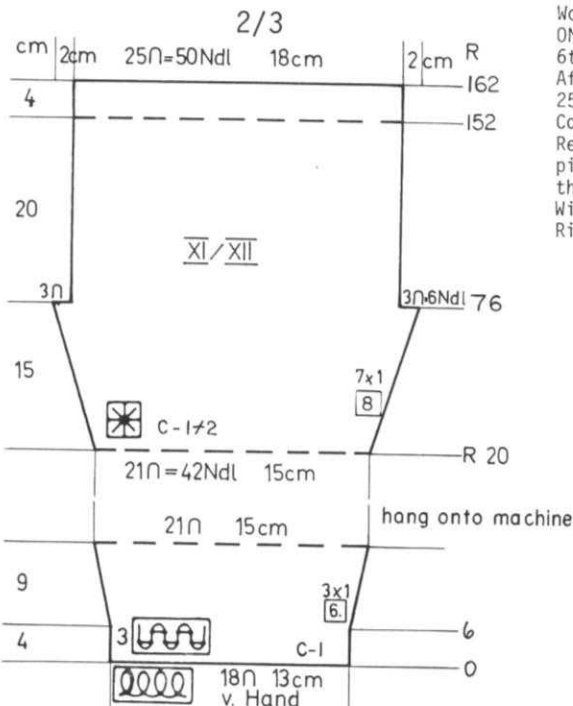

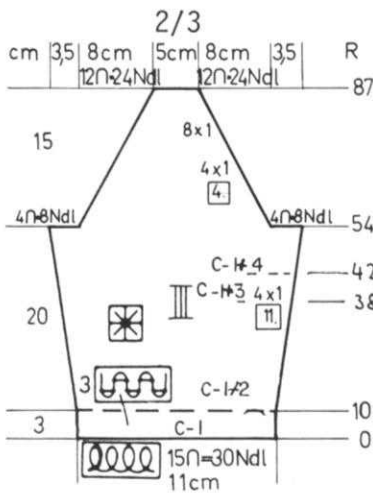

SLEEVES: III

Using Hand Knitting Needles and color 1, cast on 30 sts. and work in Ribbing same as front and back. After Row 10, transfer the sts. to the machine with 2 sts. on each EVERY OTHER NEEDLE. (15 sts.). Work in Weaving Pattern, changing the colors as shown on the Chart. ON EACH SIDE, increase 1 st. every 11th row 4x. After Row 54, ON EACH SIDE, bind off 4 actual sts. then ON EACH SIDE, decrease 1 st. every 4th row 4x, and 1 st. every 2nd row 8x. After Row 87, bind off the remaining sts.

KK 800

CHILD'S 3-PIECE SUIT
PANTS, JACKET & CAP

SIZES: 4/6 (8/10)
YARN: Euro Sport
GRAMS:
color 1 500 550
color 2 300 350
TENSION: 8 to 10
GAUGE: 11 sts. 14 rows = 5 cm (2")
A Jacket separating zipper



Stockinette stitch with color stripes as shown on the Chart. The Jacket is knitted sideways on the machine. Bands are K2, P2 Ribbing.

FINISHING: See General Instructions.
Sew in separating Jacket Zipper.
Sew Pocket to right leg of pants above the knee. (see picture).

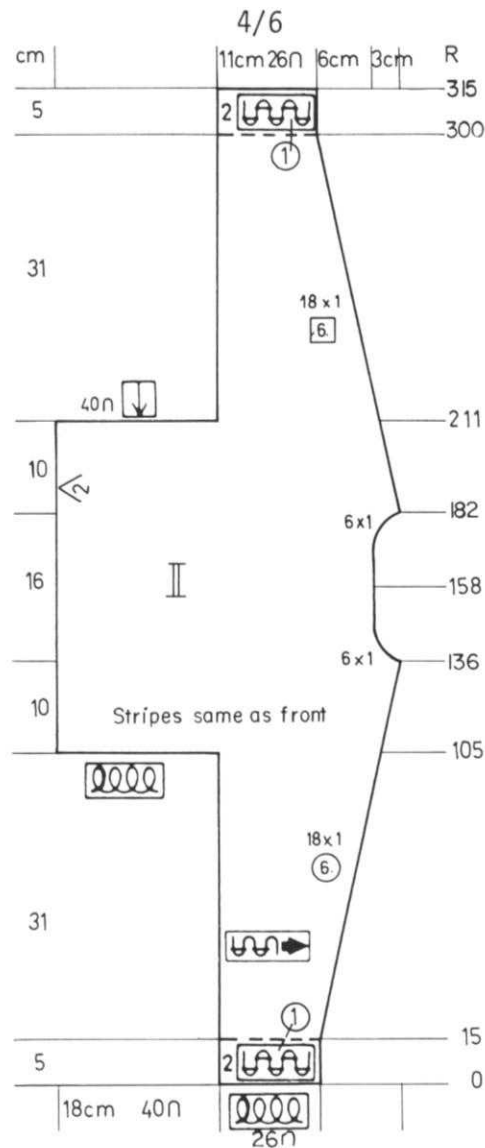

(8/10)

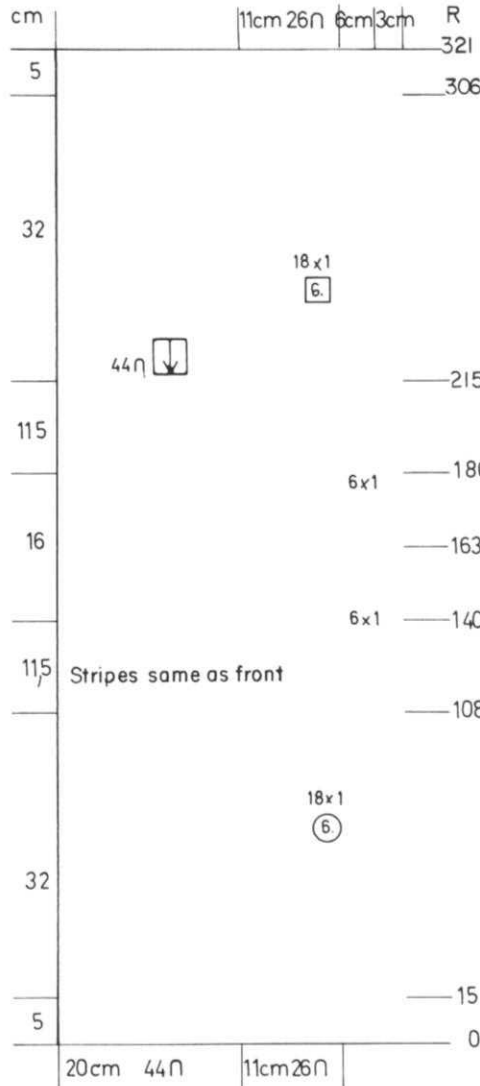

BACK: II

Cast on 26 sts. with color 1 and work 15 rows Ribbing. Continue in Stockinette stitch with color stripes same as the front and ON THE RIGHT, increase 1 st. every 6th row 18x. After Row 105 (108) ON THE LEFT, cast on 40 (44) sts. After Row 136 (140), SHAPE NECK: ON NECK SIDE, decrease 1 st. 6x for both sizes. After Row 170 (174), increase 1 st. 6x. After Row 182 (186) on the RIGHT, decrease 1 st. every 6th row 18x AND AT THE SAME TIME, after Row 211 (215), on the LEFT, bind off 40 (44) sts. After Row 300 (306), transfer the proper sts. to the Ribber and work Ribbing to Row 315 (321) then bind off.

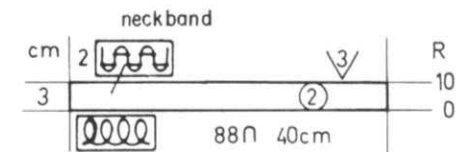

NECKBAND:

Pick up 88 sts. around neckline and work 10 rows Ribbing. Bind off.

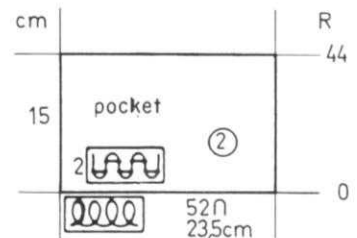

POCKET:

Cast on 52 sts. with color 2 and work 44 rows stockinette stitch. Bind off.

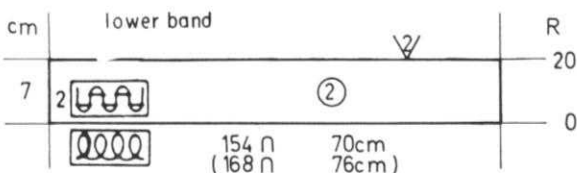

LOWER BAND:

Pick up 154 (168) sts. along lower edge and with color 2, work 20 rows Ribbing. Bind off.



KK 000

4/6

(8/10)

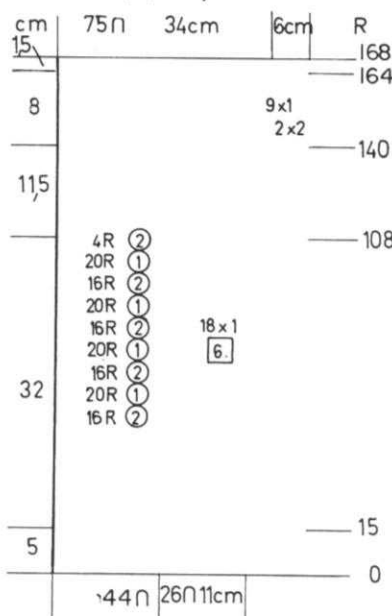
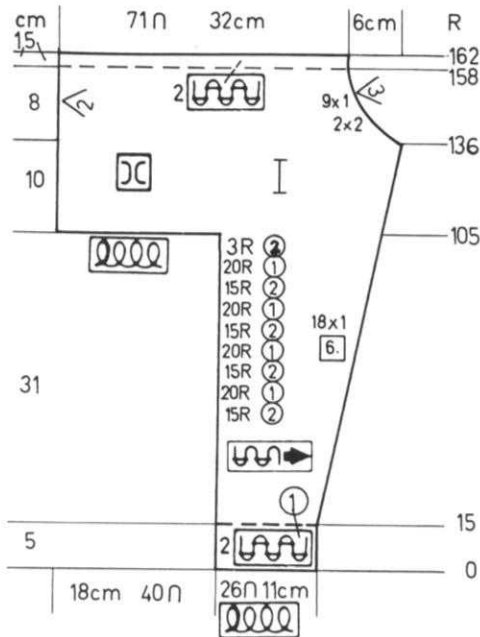

JACKET FRONT: I Make 1, reverse 1.

Cast on 26 sts. with color 1 and work 15 rows Ribbing. Continue in Stockinette stitch with color stripes as shown on the Chart AND AT THE SAME TIME on the RIGHT (left for 2nd section), increase 1 st. every 6th row 18x. Be sure to watch the color stripes for YOUR SIZE.
After Row 105 (108) on the LEFT (right) cast on 40 (44) sts.
After Row 136 (140), SHAPE NECK: Bind off 2 sts. 2x, 1 st. 9x for both sizes.

4/6

(8/10)

PANTS: XI/XII Make 2.

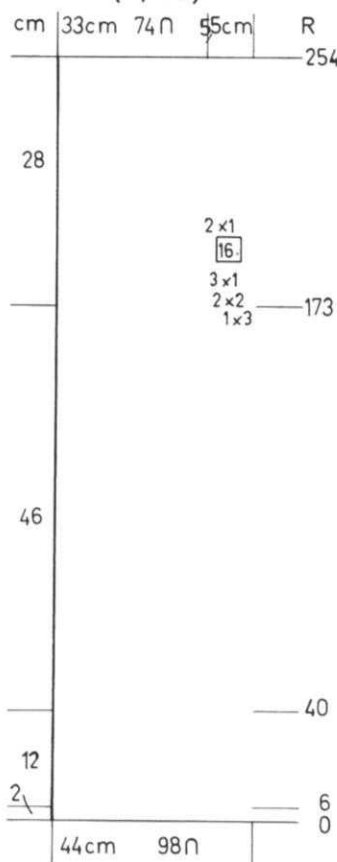
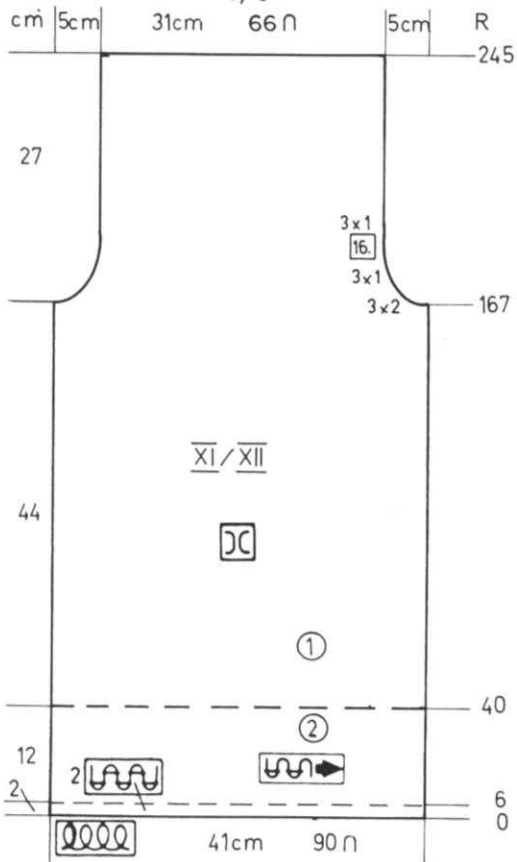

Cast on 90 (98) sts. with color 2 and work 6 rows Ribbing. Continue in Stockinette stitch to Row 40. Change to color 1. Knit to Row 167 (173). ON EACH SIDE, bind off 2 sts. 3x, 1 st. 3x, then decrease 1 st. every 16th row 3x. (3 sts. 1x, 2 sts. 2x, 1 st. 3x, then every 16th row 1 st. 2x). After Row 245 (254), bind off.

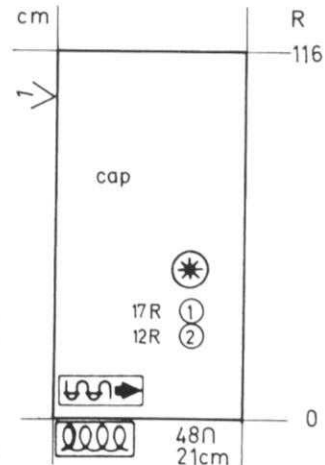

OPEN CAST ON with waste yarn. Cast on 48 sts. After waste yarn knitting, change to garment yarn and work the color stripes as shown on the Chart to Row 116. Remove onto waste yarn.

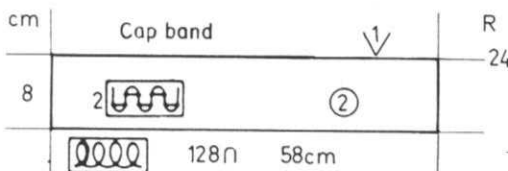

CAP BAND:

Pick up 128 sts. along one edge with color 2 and work 24 rows Ribbing. Bind off.

dk 801

WOMAN'S JACKET

SIZES: 12/14
 YARN: Heavier than Knitting
 Worsted.
 GRAMS: color 1 400
 color 2 to 7 - Small amounts of left-over colors as noted on Line Drawing.
 TENSION: 10
 GAUGE: 6 sts. 9 rows = 5 cm (2")



NOTE: KNITTED ON THE JUMBO CN9-N

The Jacket is Stockinette stitch with Garter stitch bands knitted on hand knitting needles. Work Duplicate Stitch on left side of Jacket (See KNITKING NEWS).

FINISHING: ALL BANDS are Garter stitch worked on hand knitting needles. Sew shoulder seams and set in sleeves. Sew side and sleeve seams. For the NECKBAND: Cast on 56 sts. and work 6 rows garter stitch BY HAND. Weave to the Neckline. With circular needles, pick up 88 sts. from the straight edge, add turned edge and include neckline edge. Each front, pick up 86 sts. Altogether, you should have 260 sts. on needle. Work 6 rows Garter stitch then bind off LOOSELY. Work the Bird Motif on the LEFT side of Jacket, following the Line Drawing for the Duplicate Stitch. (See KNITKING NEWS).

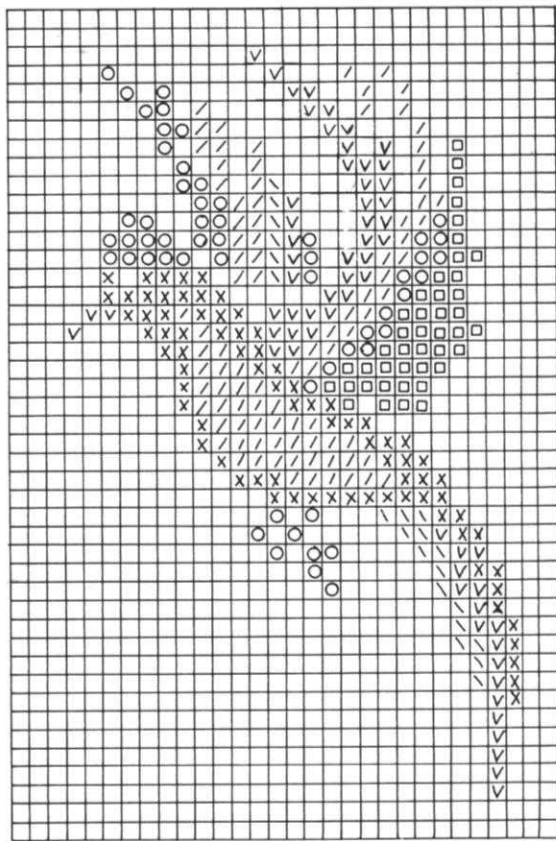

○ -Light Red
 □ -Violet
 × -Green
 ▽ -Dark Red
 / -Yellow
 \ -Lilac

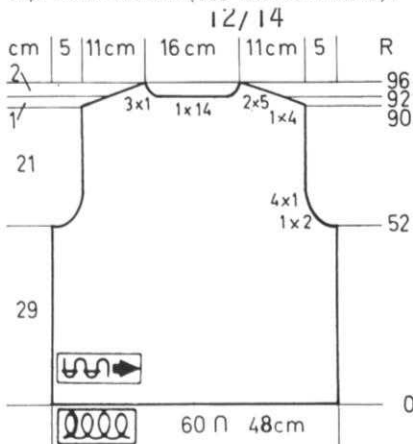

BACK:

Cast on 60 sts. Work Stockinette stitch. Knit to Row 52.
 SHAPE ARMHOLE: ON EACH SIDE, bind off 2 sts. 1x, 1 st. 4x.
 Knit to Row 90.
 SHAPE SHOULDER and WATCH FOR NECK SHAPING.
 FOR SHOULDER, bind off 4 sts. 1x, 5 sts. 2x.
 FOR NECK, After Row 92, bind off the center 14 sts., put the needles on the left into holding position and complete the right side first.
 *ON NECK SIDE, bind off 1 st. 3x. Bring the needles on the left into working position, knit 1 row to the left side, turn the Row Counter back to 92 and complete the left half. Follow the instructions from * and don't forget the shoulder shaping.

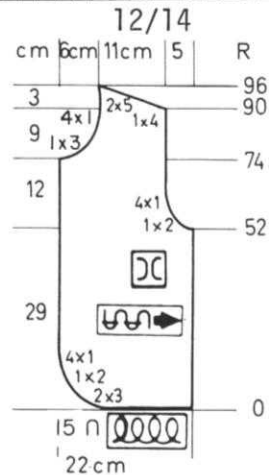

FRONT: Make 1, reverse 1.

Cast on 15 sts. and work Stockinette stitch.

ON THE LEFT (right for 2nd section) cast on 3 sts. 2x, 2 sts. 1x, 1 st. 4x.

After Row 52, SHAPE ARMHOLE:

Bind off 2 sts. 1x, 1 st. 4x.

After Row 75, SHAPE NECK:

Bind off 3 sts. 1x, 1 st. 4x.

After Row 90, SHAPE SHOULDER: Bind off 4 sts. 1x, 5 sts. 2x.

SLEEVES:

Cast on 30 sts. on hand knitting needles and work 6 rows Garter Stitch.

Hang the sts. onto the machine and continue in Stockinette stitch.

ON EACH SIDE, increase 1 st. every 8th row 8x.

After Row 80, SHAPE CAP:

ON EACH SIDE, bind off 2 sts. 2x, 1 st. 11x, 2 sts. 2x, 4 sts. 1x.

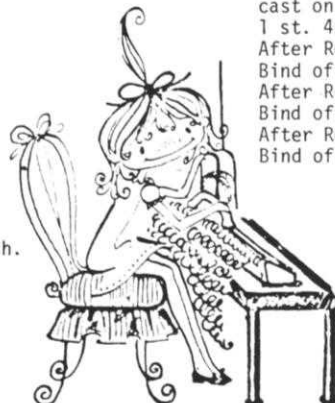
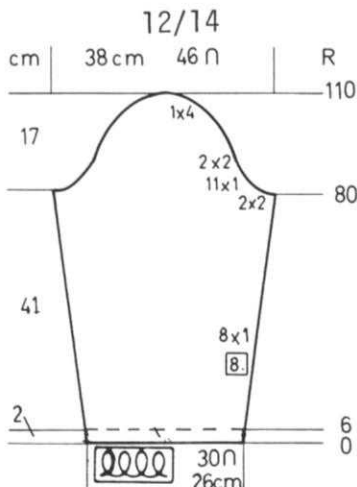

KK 802

BABY PULLOVER

SIZES: 1 to 2 years

YARN: Micaela

GRAMS:

color 1 150
color 2 50
color 3 50
color 4 50

TENSION: 7 to 8 (Pattern)
6 to 7 (Ribbing)

GAUGE: Pattern: 18 sts., 14 rows
= 5 cm - Out of work
needles are counted in gauges.
Ribbing: 11 sts. 15 rows
= 5 cm.

4 small buttons.

A Multi-colored Tuck Stitch Pattern OVER EVERY OTHER NEEDLE. The out of work needles ARE COUNTED in gauge. Punch your own Card and push in BOTH Tuck Buttons. Change color every 2 rows. The purl side is the right side.

FINISHING: See General Instructions. Leave Left shoulder open. Crochet around opening. On 2nd row, make 4 buttonholes (chain) evenly spaced. Sew buttons to back shoulder.

NOTE: Use OPEN CAST ON FOR ALL SECTIONS. Bands are to be picked up later and ribbed.

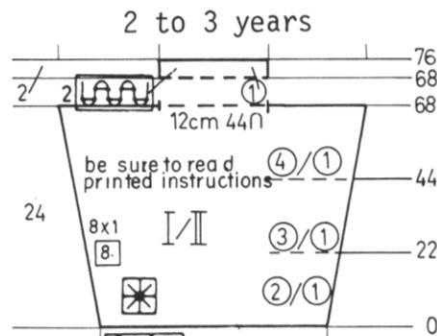
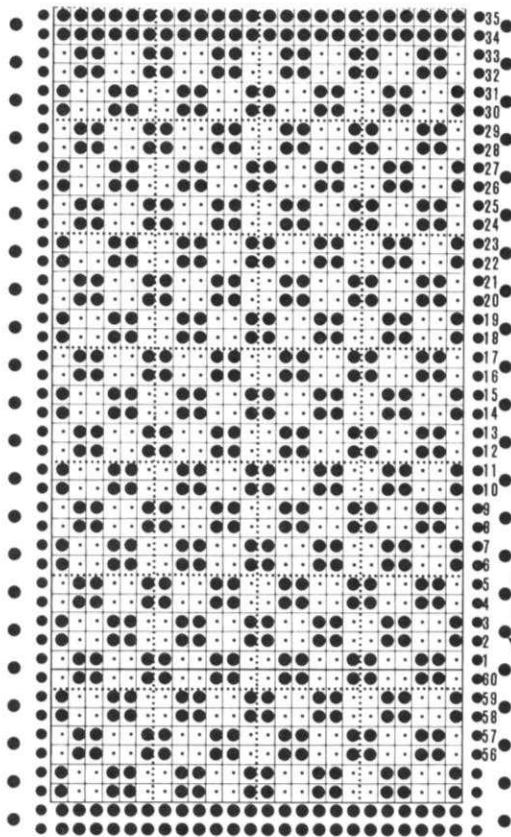

BACK & FRONT: Make 2 sections the same.

Bring 92 needles into working position then push back to the OUT OF WORK position, every 2nd needle. Cast on over the remaining 46 needles. After Waste knitting, continue in PATTERN with color 1 and 2. CHANGE COLORS as shown on the Chart.

ON EACH SIDE, increase 1 st. every 8th row 8x. After Row 68, bind off.

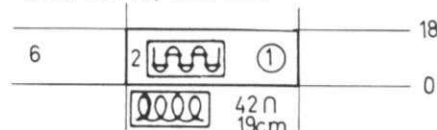

FOR WAISTBAND, pick up 42 sts. (decreasing 4 sts. evenly across) and with color 1, work 18 rows K2, P2 Ribbing. Bind off.

FOR NECKBAND: Pick up 30 sts. and work 8 rows K2, P2 Ribbing. Bind off LOOSELY using the latch tool method.

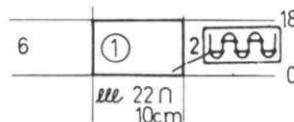

SLEEVES:

Bring 56 needles into working position then push back to the out of work position, every other needle. Cast on over the remaining 28 sts. with waste yarn. After waste knitting, continue in Pattern with color changes as shown on the Chart. ON EACH SIDE, increase 1 st. every 16th row 4x. After Row 68, bind off.

FOR THE BANDS, pick up 22 sts. decreasing 6 sts. evenly across and with color 1, work 18 rows K2, P2 Ribbing.

2 to 3 years

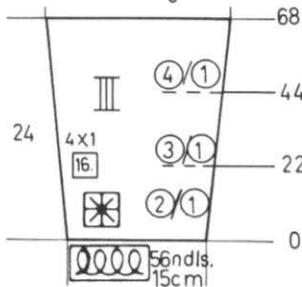

dk 803

WOMAN'S CARDIGAN SWEATER

SIZES: 8 (10) [12]

YARN: Fortissima

GRAMS:

color 1 350 400 450
color 2 50 50 50
color 3 50 50 50

TENSION: 5 to 7

GAUGE: 13 1/2 sts. 19 rows = 5 cm (2")

Stockinette stitch with color stripes on the K1, P1 Bands.

FINISHING: See General Instructions. Sew on bands.

NOTE: Work Full Fashion decreases on the armhole shaping and front neck shaping and sleeves. Hang the 3rd st. on 2nd needle and move the sts. in to fill the empty needle.



back neckband

BACK NECKBAND:

color changes for all bands

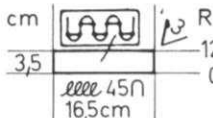

Cast on 45 sts. with color 1 and work K1, P1 Ribbing with color changes as shown. After Row 12, bind off or you can remove the sts. onto waste yarn.

- 2R ①
- 2R ②
- 1R ①
- 2R ③
- 1R ①
- 2R ②
- 2R ①

pocket band

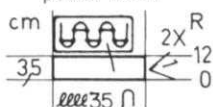

POCKET BANDS: Hang the open sts. of the pocket back onto machine and work 12 rows Ribbing with color changes same as other bands.

FRONT BANDS: Make 2, but omit buttonholes on one.

Cast on 200 sts. and work in Ribbing with color changes as shown. After Row 6, make BUTTONHOLES as shown on the Chart over 4 sts. After Row 12, bind off.

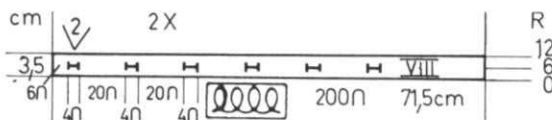

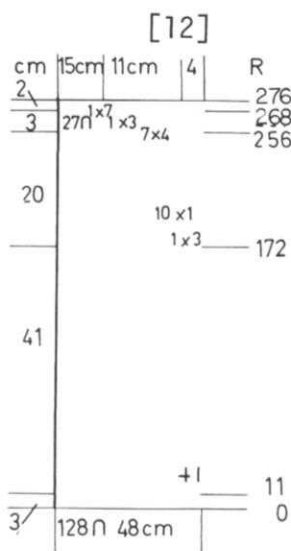
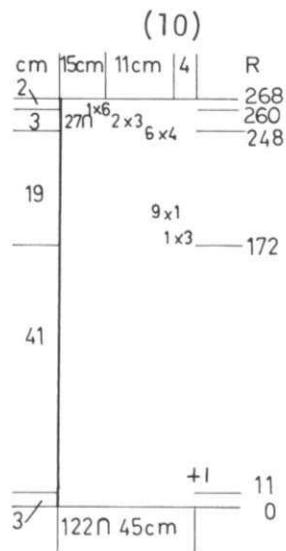
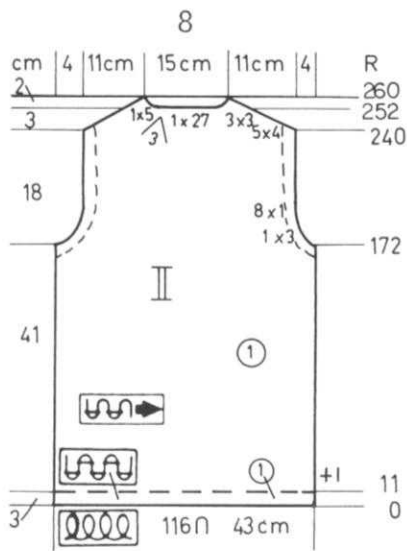

BACK: II

Cast on 116 (122) [128] sts. with color 1 and work 11 rows Ribbing. Increase 1 st. on one edge then continue in Stockinette stitch. Knit to Row 172. SHAPE ARMHOLE: ON EACH SIDE, bind off 3 sts. 1x for all sizes, then decrease 1 st. 8x (9x) [10x]. Knit to Row 240 (248) [256]. SHAPE SHOULDERS and WATCH FOR NECK SHAPING. FOR SHOULDER, ON EACH SIDE, bind off 4 sts. 5x, 3 sts. 3x. (4 sts. 6x, 3 sts. 2x). [4 sts. 7x, 3 sts. 1x]. AT THE SAME TIME, after Row 252 (260) [268], bind off the center 27 sts., put the needles on the left into holding position and complete the right side first. *ON NECK SIDE, bind off 5 (6) [7] sts. 1x. Bring the needles on the left into working position, knit 1 row to the left side, turn the Row Counter back to 252 (260) [268] and complete the left half. Follow the instructions from * but don't forget to complete the shoulder shaping.

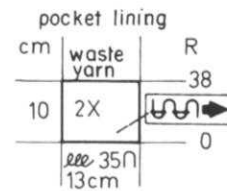

FRONT: I Make 1, reverse 1.

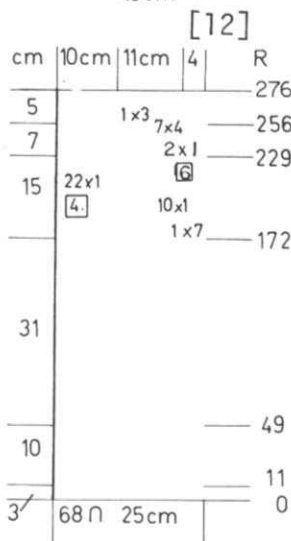
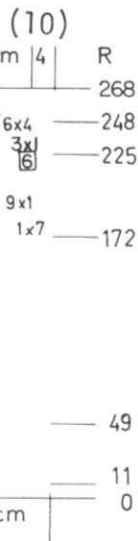
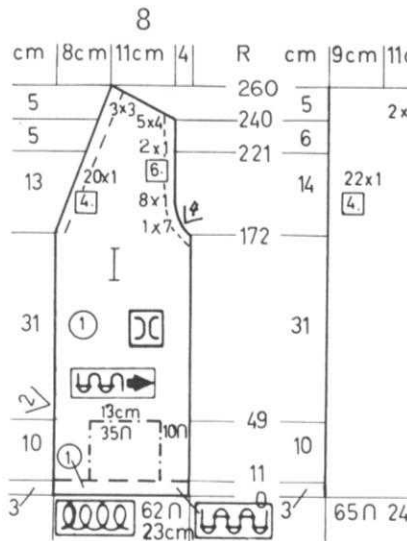

MAKE POCKET LININGS FIRST (2). Pocket Lining: - Cast on 35 sts. with color 1 and work 38 rows Stockinette stitch. Remove the sts. onto contrast waste yarn. FRONT: - Cast on 62 (65) [68] sts. with color 1 and work 11 rows Ribbing. Continue in Stockinette stitch. After Row 49, counting from the right (left for 2nd section) leave 10 sts. in work and remove the next 35 sts. onto a stitch holder. Hang the pocket lining onto these empty needles and continue over all sts. Knit to Row 172. SHAPE ARMHOLE AND NECK: ON NECK SIDE, decrease 1 st. every 4th row 20x (22x) [22x]. FOR ARMHOLE: Bind off 7 sts. 1x, 1 st. 8x then every 6th row 1 st. 2x. (7 sts. 1x, 1 st. 9x, then every 6th row 1 st. 3x). [7 sts. 1x, 1 st. 10x, then every 6th row 1 st. 2x]. After Row 240 (248) [256], SHAPE SHOULDER same as the back.

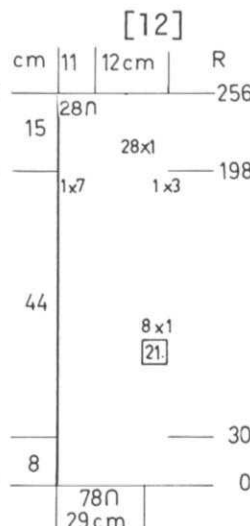
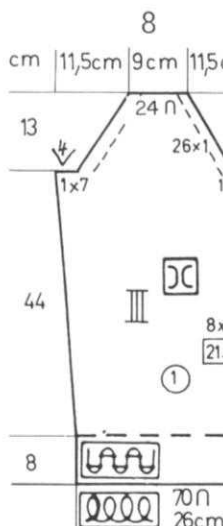

SLEEVES: III Make 1, reverse 1.

Cast on 70 (74) [78] sts. with color 1 and work 30 rows Ribbing. Continue in Stockinette stitch. ON EACH SIDE, increase 1 st. every 21st row 8x for all sizes. After Row 198, SHAPE CAP: ON THE RIGHT (left for second sleeve) bind off 3 sts. and on the LEFT (right) bind off 7 sts. for all sizes. ON EACH SIDE, decrease 1 st. 26x (27x) [28x]. After Row 248, (252) [256], bind off the remaining sts.

dk 804

WOMAN'S VEST

SIZES: 7/8 (10) [12]
 YARN: Fortissima
 GRAMS: color 1 200 200 250
 colors 2, 3, 4 - 50 grams each color for all sizes.
 TENSION: 6 to 8
 GAUGE: 13 1/2 sts. 16 rows = 5 cm (2")

A Norwegian Design. Punch your own Card. Bands are K1, P1 Ribbing.

FINISHING: See General Instructions. Sew on bands. On right front band, make BUTTONHOLES following the instructions given in the Practical Knitting Hints Column of KNITTING MAGAZINE, VOL. 15, No. 2. Make 4 buttonholes with the first at lower edge and last at beginning of neckline.



POCKET LINING (Instructions with front)

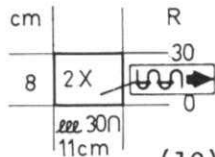

ARMBANDS Make 2.

Sew shoulder seams first, then pick up the sts. around armholes and work 6 rows K1, P1 Ribbing. Bind off.

FRONT: I Make 1, reverse 1.

Make POCKET LINING FIRST (2). FOR LINING, cast on 30 sts. with color 1 and work 30 Rows Stockinette stitch. Remove onto contrast waste yarn.

FOR FRONT: Cast on 2 sts. and work in Pattern. ON THE RIGHT (left for 2nd section) cast on 4 sts. 8x (4 sts. 7x, 5 sts. 1x) [4 sts. 6x, 5 sts. 2x] AND ON THE LEFT, cast on 1 st. 2x, 2 sts. 10x (11x) [12x]. ON SIDE EDGE, increase 1 st. every 12th row 6x for all sizes and AT THE SAME TIME after Row 44, leave 15 sts. on the LEFT (right) in work, then bind off the next 30 sts. Hang the Pocket Lining held on waste yarn onto these empty needles and continue over all needles.

After Row 110, SHAPE ARMHOLE and after Row 112, begin NECK SHAPING. FOR ARMHOLE, bind off for all sizes, 5 sts. 1x, 3 sts. 2x, 2 sts. 2x, 1 st. 4x, then on EVERY 6th ROW, INCREASE 1 st. 5x.

FOR NECK, decrease 1 st. every 3rd row 22x for all sizes. After Row 168 (170) [172], SHAPE SHOULDER. Bind off 5 sts. 4x, 3 sts. 2x. (5 sts. 4x, 4 sts. 1x, 3 sts. 1x). [5 sts. 4x, 4 sts. 2x].

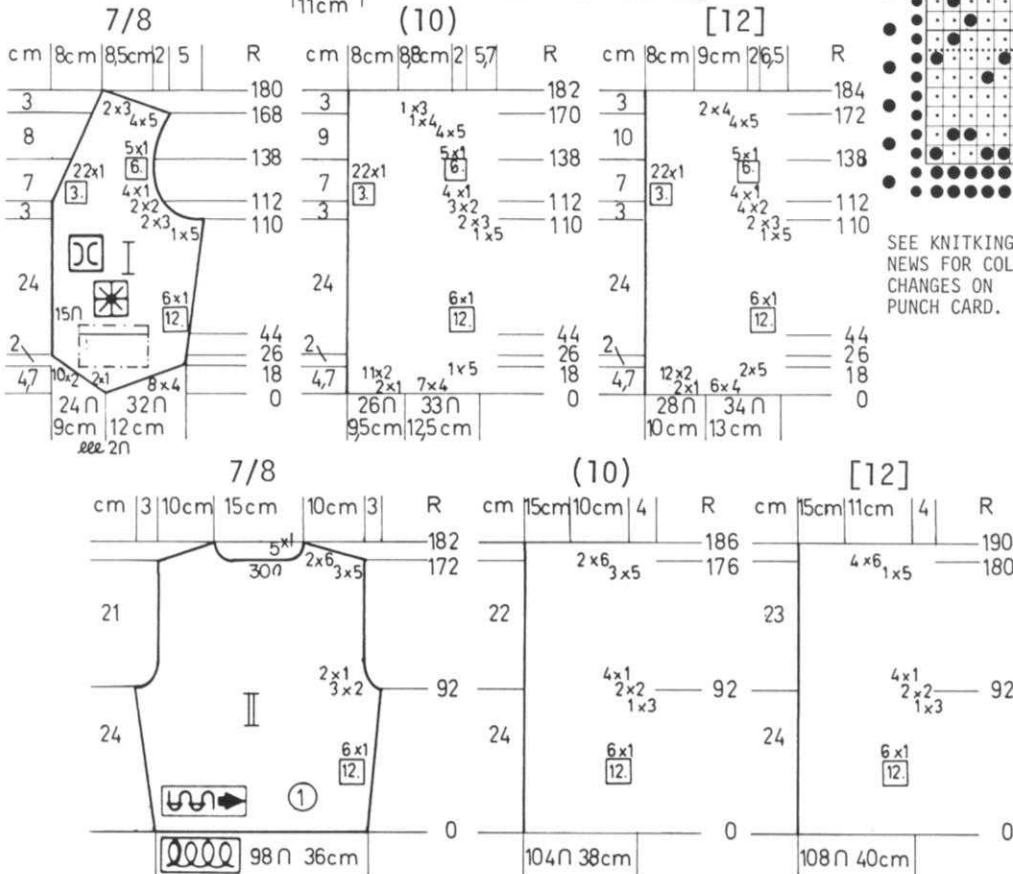
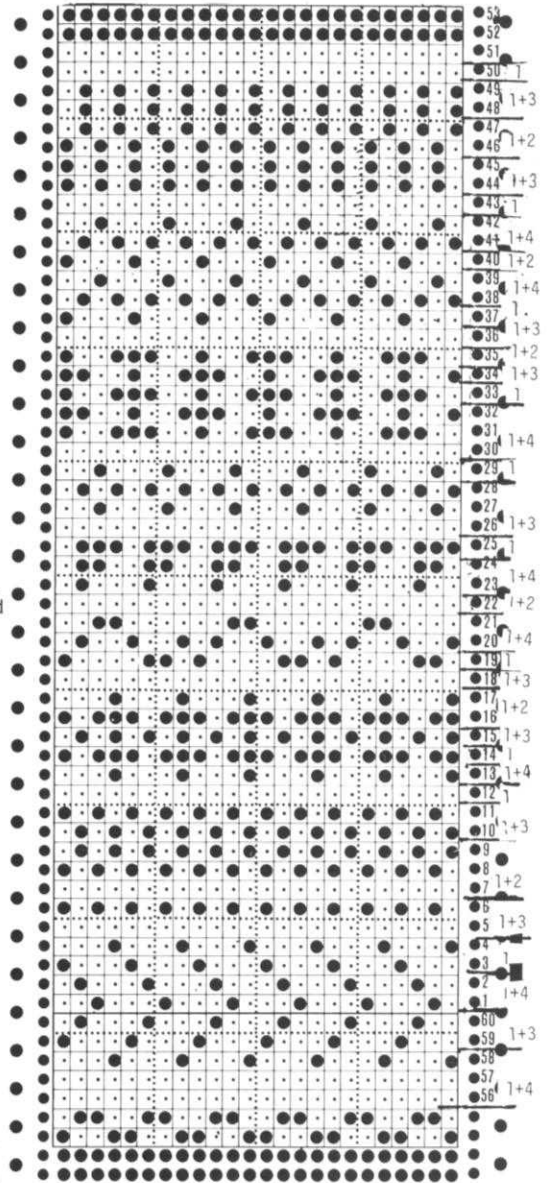

SEE KNITTING NEWS FOR COLOR CHANGES ON PUNCH CARD.

BACK: II
 The back is worked in Stockinette stitch. Cast on 98 (104) [108] sts. with color 1 and work Stockinette stitch. ON EACH SIDE, increase 1 st. every 12th row 6x for all sizes. After Row 92, SHAPE ARMHOLE: ON EACH SIDE, bind off 2 sts. 3x, 1 st. 2x. (3 sts. 1x, 2 sts. 2x, 1 st. 4x). [3 sts. 1x, 2 sts. 2x, 1 st. 4x]. After Row 172 (176) [180], Bind off the center 30 sts. put the needles on the left into holding position and complete the right side first. SHAPE SHOULDER AND NECK AT THE SAME TIME: FOR SHOULDER, bind off 5 sts. 3x, 6 sts. 2x. (Same as first size) [5 sts. 1x, 6 sts. 4x]. FOR NECK, bind off 1 st. 5x for all sizes. Bring the needles on the left into working position, knit 1 row to the left side, turn the Row Counter back to 172 (176) [180] and complete the left half. Follow the instructions from *.

FRONT BAND: Make 2.

BACK NECKBAND:

Cast on 200 sts. and work 6 rows Ribbing. Latch Tool Bind off.

Cast on 40 sts. and work 6 rows Ribbing. Latch Tool Bind off.

POCKET BAND: Make 2.

Cast on 30 sts. and work 6 rows Ribbing. Remove onto contrast and weave to pocket slit. Remove contrast.

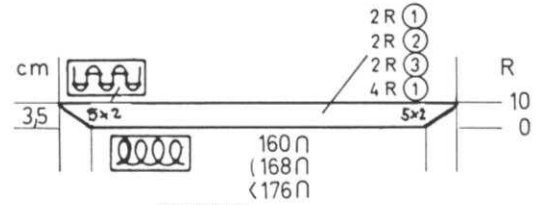

NECKBAND:

Cast on 160 (168) [176] sts. with color 1 and work in Ribbing with color stripes as shown on the Chart AND AT THE SAME TIME, ON EACH SIDE, increase 2 sts. 5x. Bind off.

np 805

Stockinette stitch with color stripes on bands as shown on the Charts. Bands are K1, P1 Ribbing.

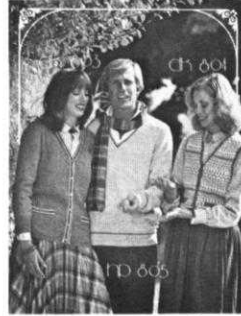

MAN'S PULLOVER

FINISHING: See General Instructions.

SIZES: 36 (38) [40]
 YARN: Fortissima
 GRAMS:
 color 1 400 450 500
 color 2 50 50 50
 color 3 50 50 50
 TENSION: 5 to 7
 GAUGE: 13 1/2 sts. 16 rows = 5 cm (2")

NOTE: All increases and decreases are full fashion. For increases, move 2 end sts. out then pick up a stitch from row below and hang it onto empty needle. For Decreases, hang the 3rd end st. onto the 2nd needle and move the sts. in to fill empty needle.

FRONT: I

Work the front the same as the back to Row 160 (168) [176]. Divide in the center, put the needles on the left into holding position and complete the right side first.

*SHAPE NECK and SHAPE ARMHOLE: FOR ARMHOLE, bind off 7 sts. 1x for all sizes then decrease 1 st. 8x (10x) [12x], and FOR NECK, decrease 1 st. every 3 row 20x (20x) [22x]. After Row 220 (232) [244], ON ARM SIDE, increase 1 st. every 4th row 8x for all sizes. After Row 260 (268) [276], bind off the remaining sts. Bring the needles on the left into working position, knit 1 row to the left side, turn the Row Counter back to 160 (168) [176] and complete the left half. Follow the instructions from *.

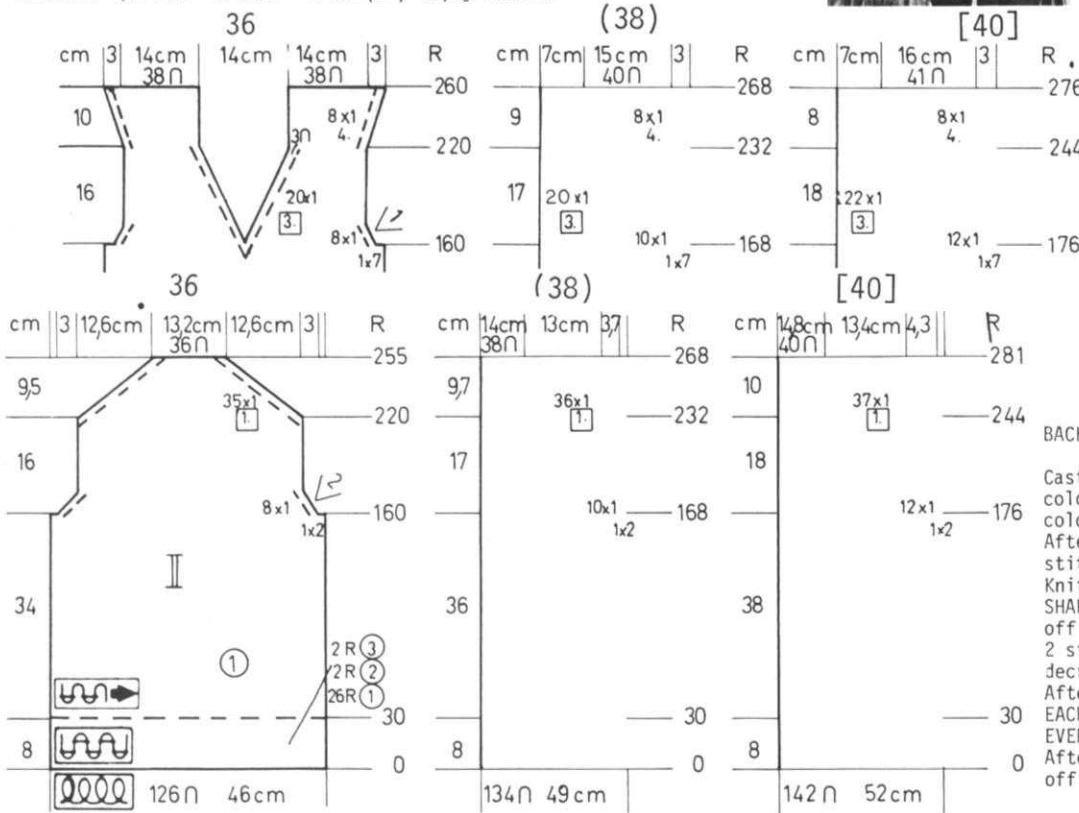

BACK: II

Cast on 126 (134) [142] sts. with color 1 and work in Ribbing with color stripes as shown on the Chart. After Row 30, continue in Stockinette stitch with color 1. Knit to Row 160 (168) [176]. SHAPE ARMHOLE: ON EACH SIDE, bind off 2 sts. 1x for all sizes, then decrease 1 st. 8x (10x) [12x]. After Row 220 (232) [244], ON EACH SIDE, decrease 1 st. EVERY ROW 35x (36x) [37x]. After Row 255 (268) [281], bind off the remaining sts.

SLEEVES: III Make 1, reverse 1.

Cast on 73 (78) [83] sts. with color 1 and work 30 rows Ribbing with color changes as shown on the chart. Continue in Stockinette stitch with color 1. ON EACH SIDE, increase 1 st. every 18th row 8x for all sizes. After Row 174 (178) [182], SHAPE ARMHOLE: ON THE RIGHT, (left) bind off 2 sts. and ON THE LEFT (right) bind off 7 sts. for all sizes, then decrease 1 st. ON EACH SIDE, every 2nd row 26x (28x) [30x]. After Row 227 (235) [243], bind off the remaining sts.

dk 006

WOMAN'S 3-PIECE EVENING SUIT

SIZES: 8/10 (12)
 YARN: Color 1 = Capriccio
 Color 2 = Micaela

GRAMS:
 color 1 450 500
 color 2 200 250
 TENSION: 5 to 7
 GAUGE: Camisole - 14 1/2 sts.,
 20 rows = 5 cm (2")
 Skirt & Jacket - 13 1/2
 sts. 19 rows = 5 cm (2")

The Jacket & Skirt are a Norwegian Design. Punch your own Card. The Camisole is an Eyelet Design and the Ribber is used. You must transfer the stitches for the Eyelets following the Line Drawing.

FINISHING: See General Instructions.
 Skirt: Fold over waistband to the inside and sew in place. Insert elastic through casing.
 JACKET: Row 1: Work*double crochet, chain 1 and REPEAT around Jacket edges. Row 2: Single crochet in each double crochet, ch 1. Repeat around. SLEEVES: Gather top of cap to measure 12 cm across shoulders. Work the same crochet around lower edge of sleeve, gathering to fit wrist on first row.

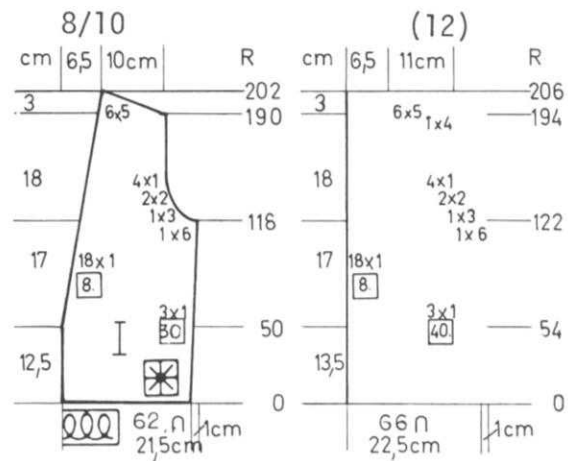

JACKET BACK: II

Cast on 132 (140) sts. with color 1 and work the Norwegian Design. ON EACH SIDE, increase 1 st. every 30th row 3x. (every 40th row 3x). After Row 118 (122), SHAPE ARMHOLE: ON EACH SIDE, bind off for both sizes, 5 sts. 1x, 3 sts. 1x, 2 sts. 2x, 1 st. 4x. After Row 190 (194), SHAPE SHOULDER (AND WATCH FOR NECK SHAPING). FOR SHOULDER, ON EACH SIDE, bind off 5 sts. 6x, (4 sts. 1x, 5 sts. 6x), AT THE SAME TIME, after Row 196 (200) bind off the center 32 sts., put the needles on the left into holding position and complete the right side first. *ON NECK SIDE, bind off 2 sts. 3x for both sizes. Bring the needles on the left into working position, knit 1 row in Pattern to the left side, turn the Row Counter back to 196 (200) and complete the left half. Follow the instructions from * but don't forget to complete the shoulder shaping.

JACKET FRONT: I

Make 1, reverse 1..

Cast on 62 (66) Sts. with color 1 and work the Norwegian Design ON SIDE EDGE, increase 1 st. every 30th (40th) row 3x AND AT THE SAME TIME after Row 50 (54), SHAPE FRONT NECK: Decrease 1 st. every 8th row 18x for both sizes. After Row 116 (122), SHAPE ARMHOLE: Bind off for both sizes, 6 sts. 1x, 3 sts. 1x, 2 sts. 2x, 1 st. 4x. After Row 190 (194), SHAPE SHOULDER: Bind off 5 sts. 6x. (4 sts. 1x, 5 sts. 6x).

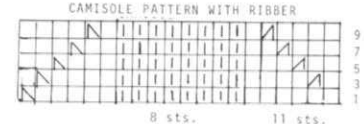
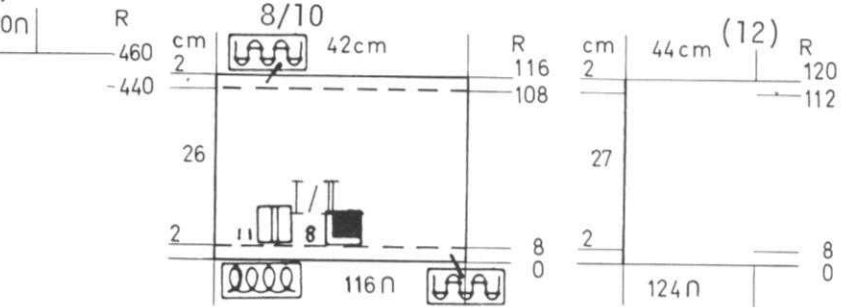
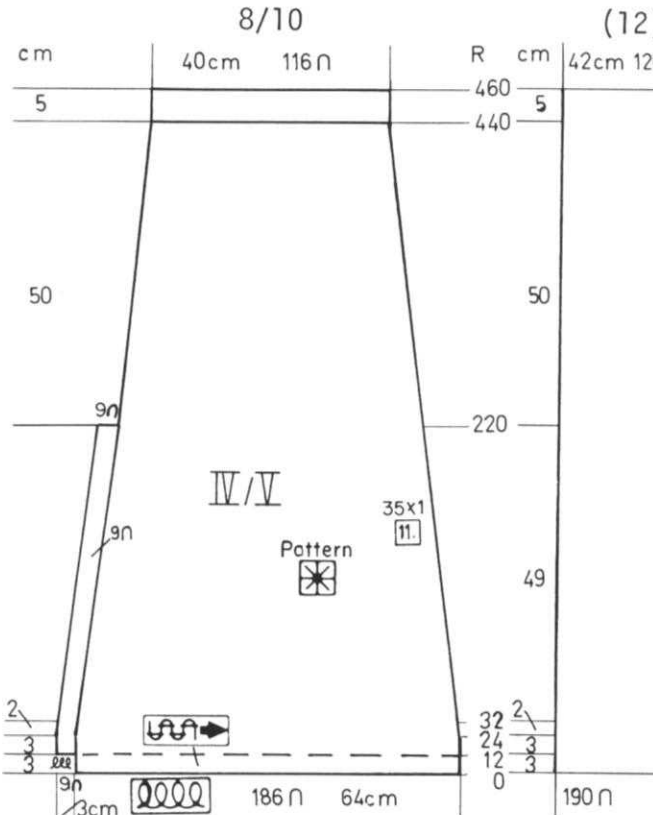
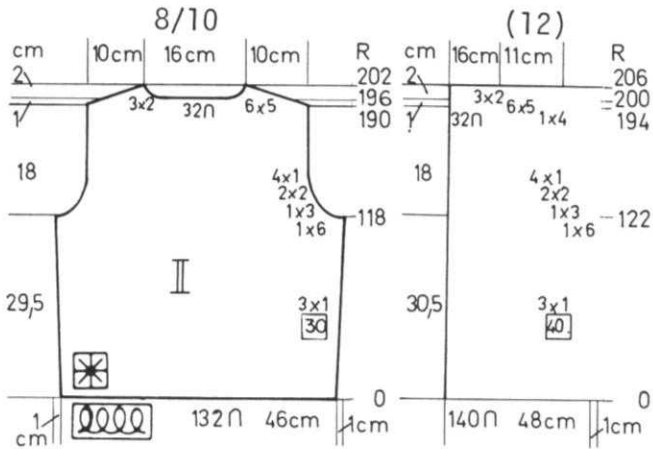

CAMISOLE TOP I/II - Make 2 sections the same. Cast on 116 (124) sts. with color 2 and work 8 rows K1, P1 Ribbing. Set up the Pattern as shown on the Line Drawing and work the Eyelet Design and Ribbing to Row 108 (112). Continue in K1, P1 Ribbing to Row 116 (120). Bind off.

SKIRT: IV/V - Two sections (reverse 1).

Cast on 186 (190) sts. with color 1 and work Stockinette stitch. After Row 12, ON THE LEFT (right for second section), cast on 9 sts. then knit to Row 24. ON EACH SIDE, decrease 1 st. every 11th row 35x for both sizes AND AT THE SAME TIME, after Row 32, begin the NORWEGIAN DESIGN. After Row 440, continue in Stockinette stitch to Row 460. Bind off.

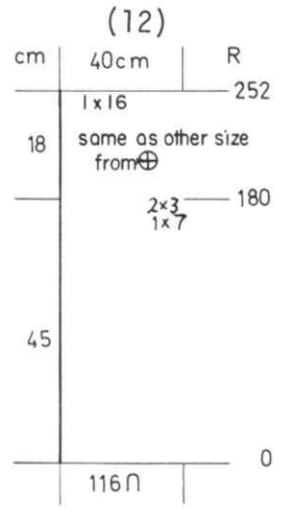
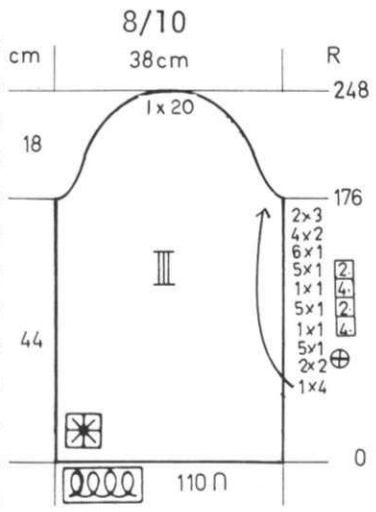
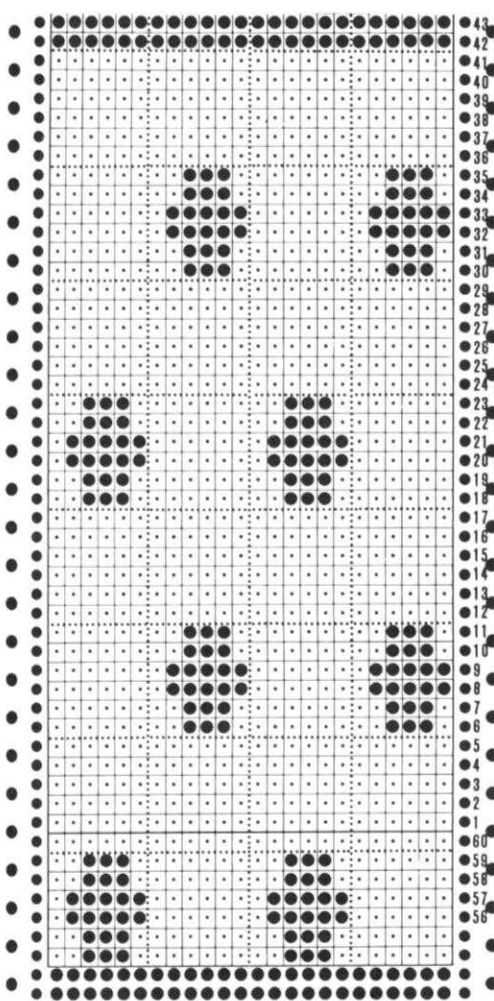

SLEEVES: III

Cast on 110 (116) sts. with color 1 and work the Norwegian Design. Knit to Row 176 (180).
 SHAPE CAP: ON EACH SIDE, bind off 4 sts. 1x, 2 sts. 2x *1 st. 5x, knit 4 rows, 1 st. 1x, every 2nd row 1 st. 5x, knit 4 rows, 1 st. 1x, every 2nd row 1 st. 5x, 1 st. 6x, 2 sts. 4x, 3 sts. 2x.
 (7 sts. 1x, 3 sts. 2x, then follow the instructions for first size from *.
 After Row 248 (252), bind off the remaining sts.

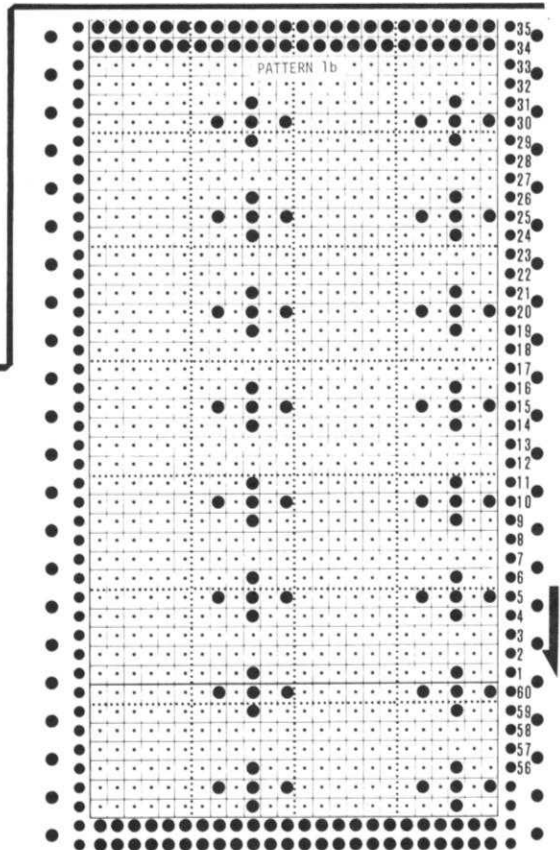

DK 807

WOMAN'S JACKET

SIZES: 5/6 (7/8)
 YARN: Euro Sport
 GRAMS:
 color 1 250 300
 color 2 200 200
 color 3 150 150
 color 4 50 50
 TENSION: 7 to 9
 GAUGE: 10 sts. 11 rows = 5 cm (2")

ROWS & COLOR CHANGES FOR PATTERN

Pick up 11 rows Ribbing - Color 1 (later)
 Begin here. 8 rows Pat. 1a - Colors 3 + 4
 2 rows " - Colors 1 + 2
 50 rows Pat. 1b - Colors 1 + 2
 10 rows Pat. 1a (upside down)
 Colors 3 + 4
 2 rows Stock - Color 2
 25 rows Star (hand set)
 Colors 2 + 3
 2 rows Stock - Color 2
 2 rows Stock - Color 4
 2 rows Stock - Color 3

A Norwegian Design knitted over EVERY OTHER NEEDLE. Punch your own Cards for Pattern 1a and 1b. The Norwegian Star Design will have to be manually set. Rib Bands.

FINISHING: See General Instructions. Weave on the Neckband, turn half to the inside and sew in place. Work 1 row single crochet down front edges then 1 row reverse single crochet. Sew in Separating Jacket Zipper.

NOTE: Begin all sections with contrast waste yarn (open cast-on) then pick up the sts. and work the Ribbing later.
 Work Pattern # 1a
 Pattern # 1b
 Pattern # 1a UPSIDE DOWN
 then Pattern # 2 (Norwegian Star Design to be manually set).

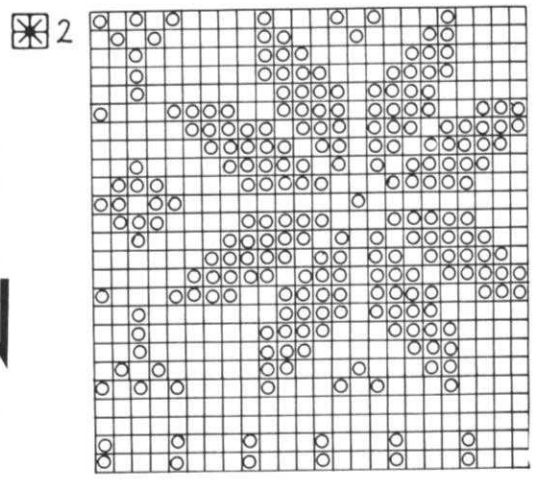
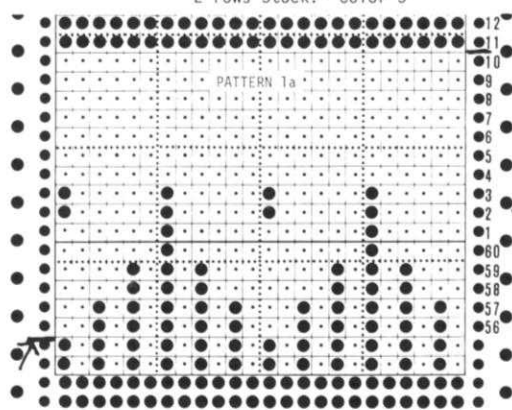

dk 807

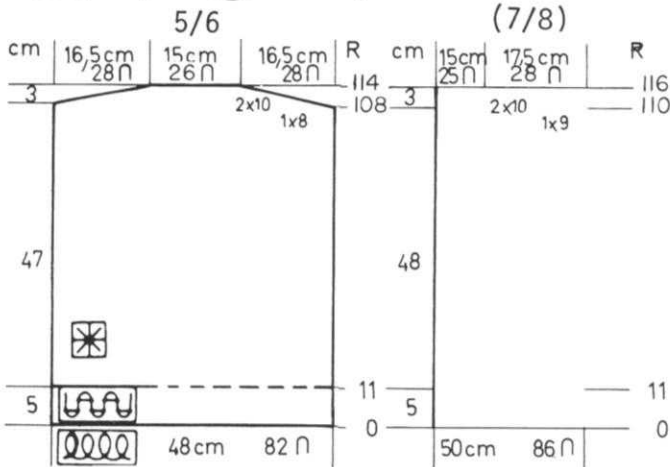

BACK:

OPEN CAST ON WITH WASTE YARN. Cast on 82 (86) sts. OVER EVERY OTHER NEEDLE. Put Counter at 11 and work in Pattern to Row 108 (110). SHAPE SHOULDER: ON EACH SIDE, bind off 8 sts. 1x, 10 sts. 2x. (9 sts. 1x, 10 sts. 2x). After Row 114 (116), bind off the remaining sts.

NECKBAND:

Cast on 65 sts. using EVERY 4th NEEDLE ON MACHINE and EVERY 4th needle on the RIBBER. Work 22 rows K1, P1 Ribbing then remove onto waste yarn.

SLEEVES:

OPEN CAST ON WITH WASTE YARN. Cast on 42 (48) sts. Put Counter at 13. Continue in Pattern. ON EACH SIDE, increase 1 st. every 6th row 12 x for both sizes. After Row 112, bind off.

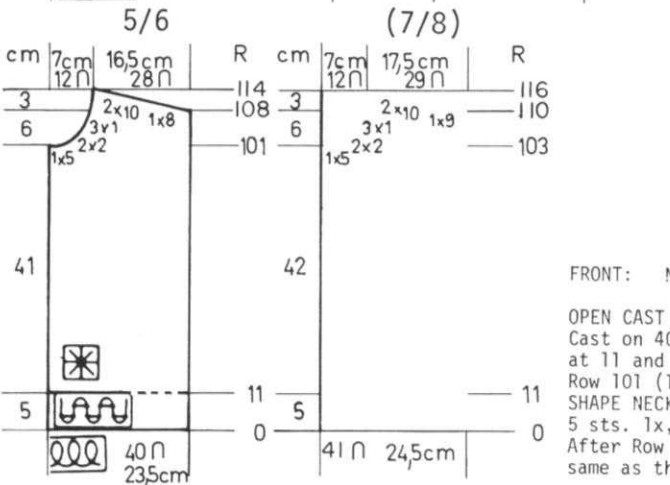

FRONT: Make 1, reverse 1.

OPEN CAST ON WITH WASTE YARN. Cast on 40 (41) sts. Put Counter at 11 and work in Pattern to Row 101 (103). SHAPE NECK: Bind off 5 sts. 1x, 2 sts. 2x, 1 st. 3x. After Row 108 (110) SHAPE SHOULDER same as the back.

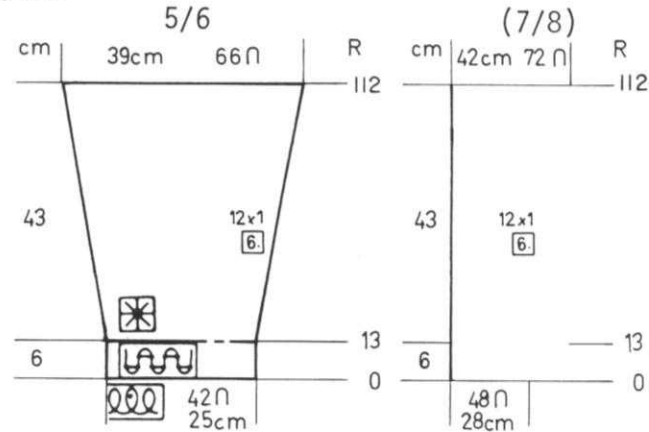

FOR ALL BANDS HELD ON WASTE YARN. Hang the open sts. onto machine. (EON) Transfer EVERY 2nd STITCH TO THE RIBBER - so you will be using every 4th NEEDLE ON THE RIBBER AND EVERY 4th NEEDLE ON THE MAIN MACHINE. Remove the waste yarn and work 11 rows K1, P1 Ribbing. Bind off.

dk 808

WOMAN'S PULLOVER & CAP

SIZES: 7/8 (10/12)
YARN: Euro Sport
GRAMS:
color 1 250 300
color 2 250 300
color 3 250 300
TENSION: 10
GAUGE: 14 sts. 18 rows = 5 cm (2")

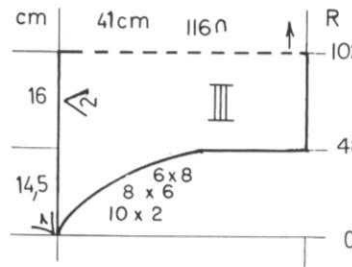

SLEEVES: III

To the extreme left of machine, cast on 2 sts. with color 1. Work Stockinette stitch. ON THE RIGHT, on every 2nd row, cast on 2 sts. 9x more, then cast on 6 sts. 8x, 8 sts. 6x. After Row 48, continue in the Norwegian Design. (Be sure to match Pattern to front and back). Knit in Pattern to Row 102. Reverse the instructions for 2nd half of sleeve - begin with 54 rows then work the bind-offs in reverse from the beginning cast ons, and work in Stockinette stitch with color 1 when shaping.

This was originally a hand knit pattern and has been adapted for the machine. The machine knit design was made for a 24 stitch repeat so the actual garment will not look exactly like the picture. Punch your own Card for the Norwegian Designs. Bands are K2, P2 Ribbing (or K1, P1).

FINISHING: Close shoulder seams. Put sleeves in - watch the design and match to front and back. Sew on cuffs then sew side and sleeve seams. Turn half the neckband to the inside and sew in place. CAP: Sew the 4 top sections together then sew up back seam. Pull top of cap together and secure.

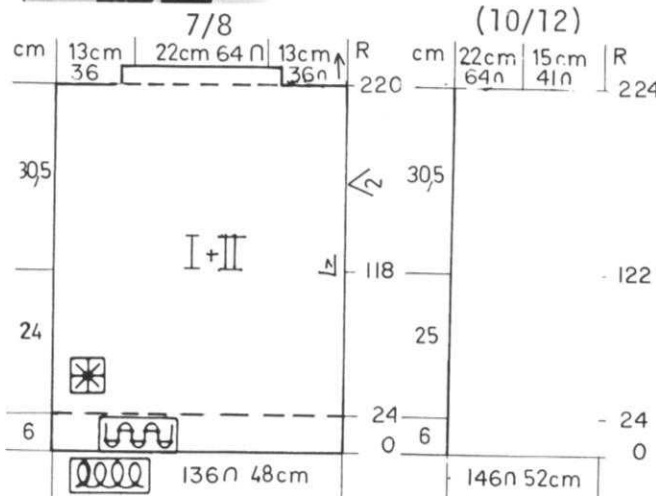

BACK & FRONT: (2 sections the same).

Cast on 136 (146) sts. with color 1 and work 24 rows Ribbing. Continue in the Norwegian Design. After Row 118 (122), mark each side for setting in sleeve. (Mark Pat. Row). Knit to Row 220 (224). ON EACH SIDE, bind off 36 (41) sts. Continue in Ribbing for 8 rows. Bind off.

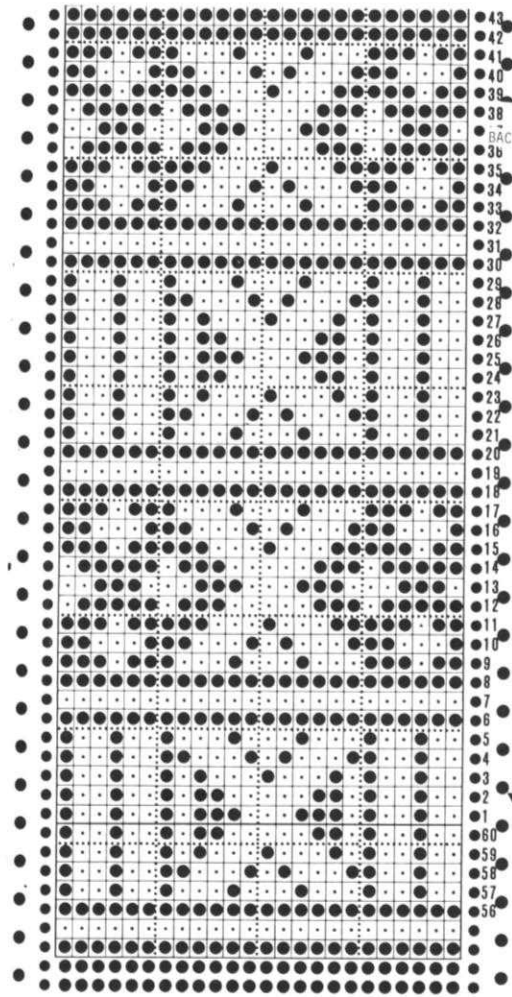

BACK & FRONT

COLORS for BACK, FRONT & SLEEVES

- * 1 row - Red
 - 1 row - White
 - 1 row - Black
 - 9 rows - Black & White
 - 1 row - Black
 - 1 row - White
 - 1 row - Red
 - 9 rows - Red & White
- REPEAT FROM *

COLORS FOR CAP

- PATTERN 1**
- 1 row - White
 - 1 row - Black & White
 - 7 rows - Black & White
 - 1 row - White
- PATTERN 2**
- * 1 row - White
 - 3 rows - Red & White
 - 1 row - White
- REPEAT FROM *

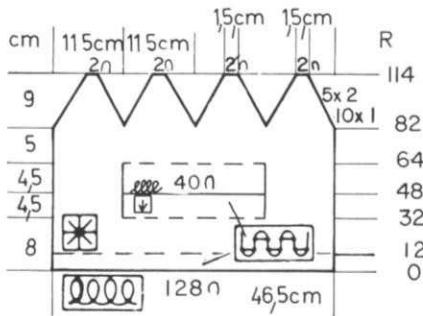

CAP:

Cast on 128 sts. and work 12 rows Ribbing.
 Continue in Pattern to Row 32
 After Row 32, work Ribbing over the center 40 sts. the rest Stockinette.
 After Row 48, bind off the center 40 sts. then immediately cast on over these same needles and continue with the ribbing over the center 40 sts. to Row 64.
 Continue in Pattern over all needles to Row 82.
 Change to Stockinette stitch and work the 4 sections separately.
 Work over the first 32 sts and put the remaining needles into holding position.
 *ON EACH SIDE, decrease 1 st. every 2nd row 10x, 2 sts. 5x. Bind off the remaining 2 sts.
 Bring the next 32 sts. into working position and REPEAT from *
 Continue in this way for 3 more sections.

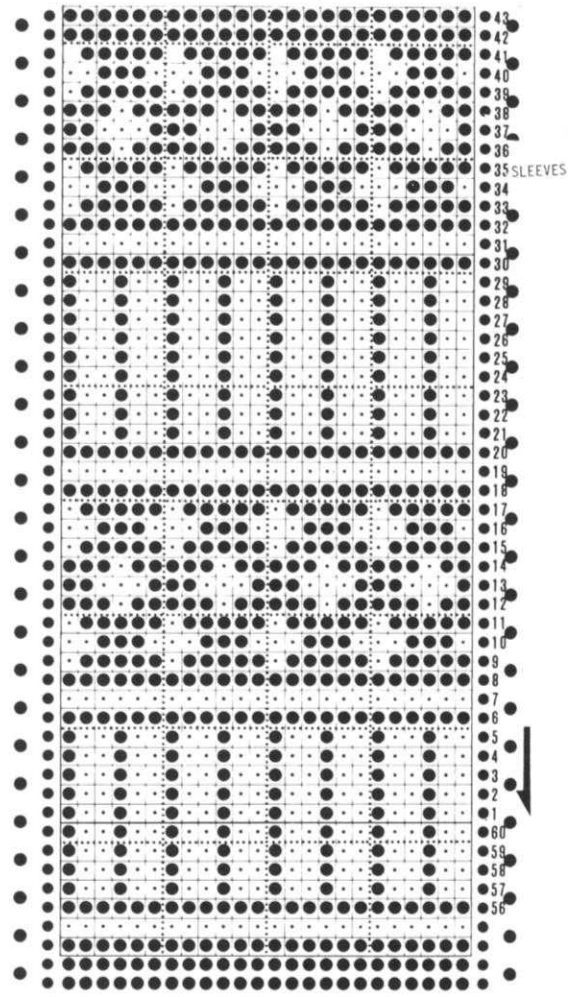

SLEEVES

CUFFS: Make 2.

Cast on 52 sts. and work 20 rows Ribbing. Bind off.

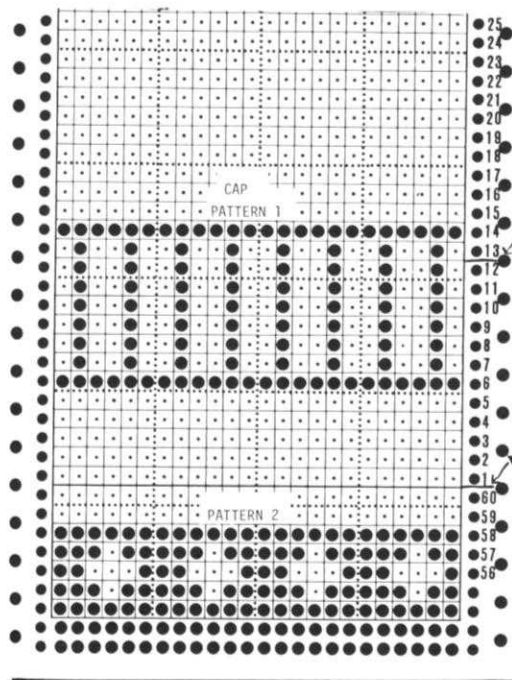

WOMAN'S VEST & CARDIGAN

SIZES: 12 (14) [16]

YARN: Micaela or Vienna

GRAMS: - PULLOVER

color 1	150	200	250
color 2	50	50	50
color 3	50	50	50
color 4	50	50	50

GRAMS: - CARDIGAN

color 1	350	350	400
color 2	Few Yards for all sizes		
color 3	Few Yards for all sizes		

GAUGE: TENSION 6 to 8

Pat. #1-12 sts. 15 1/2 rows = 5 cm
 Pat. #2-13 sts. 13 1/2 rows = 5 cm

The Vest is in a Norwegian Design. Punch your own Card. The Cardigan is an Eyelet Design using the Ribber and following the Line Drawing. Bands are K1, P1 Ribbing.

FINISHING: See General Instructions. Finish Buttonholes and sew on Buttons.



dk 809

dk 009

VEST BACK: IIa

Cast on 126 (137) [144] sts. with color 1 and work 8 rows Ribbing. Continue in the Norwegian Design. Knit to Row 94 (98) [100]. SHAPE ARMHOLE: ON EACH SIDE, bind off 8 (11) [14] sts. Knit to Row 148 (152) [158]. Bind off the center 26 (25) [26] sts. put the needles on the left into holding position and complete the right side first. *SHAPE SHOULDER AND NECK AT THE SAME TIME. FOR SHOULDER, bind off 12 sts. 3x, (13 sts. 3x), [13 sts. 3x], FOR NECK, bind off 3 sts. 2x for all sizes. Bring the needles on the left into working position, knit 1 row in Pattern to the left side, turn the Row Counter back to [48 (152) [158]] and complete the left half. Follow the instructions from *.

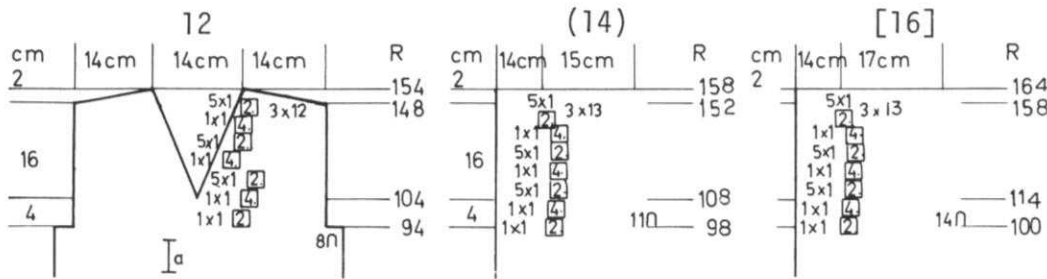
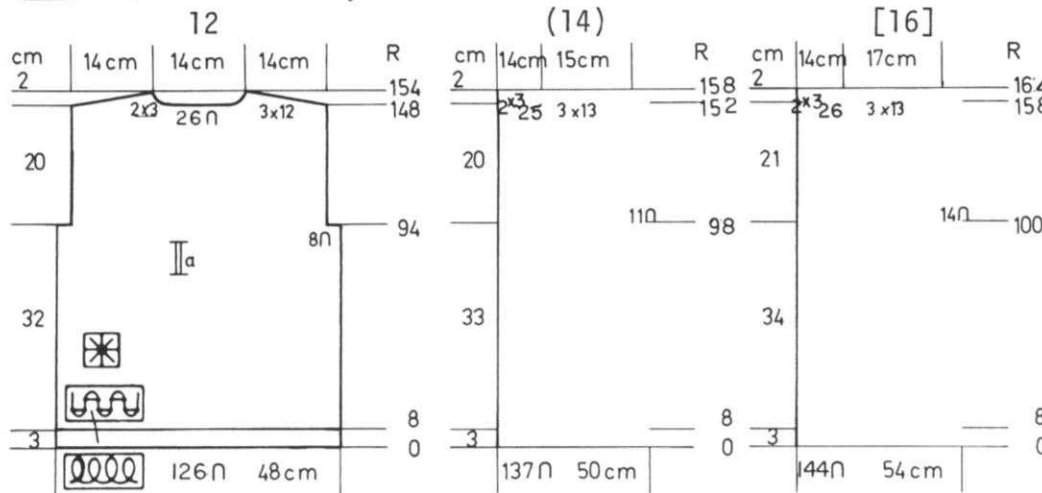

VEST FRONT: Ia

CARDIGAN BACK: II

Cardigan

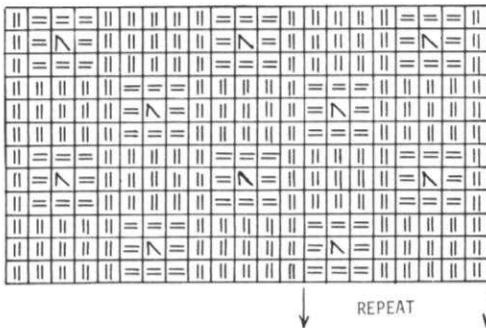

Work the front the same as the back to Row 104 (108) [114]. Put half the sts. on the left into holding position and complete the right side first. *Please follow the instructions for the NECK SHAPING as given on the Chart for YOUR SIZE. After Row 148 (152) [158], SHAPE SHOULDER same as the back. Bring the needles on the left into working position, knit 1 row in Pattern to the left side, turn the Row Counter back to 104 (108) [114] and complete the left half. Follow the instructions from *.

Cast on 117 (123) [133] sts. and work 7 rows Ribbing. Continue in Ribbing Pattern with Eyelet Design following the Line Drawing for setting up the needles and Pattern. Knit to Row 110 (114) [118]. SHAPE ARMHOLE: ON EACH SIDE, bind off 5 sts. 1x, 3 sts. 1x, 2 sts. 1x, 1 st. 4x. (5 sts. 1x, 4 sts. 1x, 2 sts. 1x, 1 st. 4x). [6 sts. 1x, 4 sts. 1x, 2 sts. 1x, 1 st. 4x]. AT SAME TIME, after Row 123 (126) [129], transfer the ribber sts. to main machine and work the Stripes in Stockinette st. 2 rows color 2, 2 rows color 3, 2 rows color 2. Transfer the proper sts. to Ribber and continue in the Eyelet Pattern. Knit to Row 168 (176) [186]. SHAPE SHOULDER AND WATCH FOR NECK SHAPING. FOR SHOULDER, bind off 5 sts. 4x, 6 sts. 1x, (5 sts. 4x, 8 sts. 1x), [6 sts. 4x, 8 sts. 1x], FOR NECK: After Row 172 (180) [190], bind off the center 27 sts., put the needles on the left into holding position and complete the right side first. ON NECK SIDE, for all sizes, bind off 3 sts. 1x, 2 sts. 1x. Bring the needles on the left into working position, knit 1 row in Pattern to the left side, turn the Row Counter back to 172 (180) [190] and complete the left half. Follow the instructions from * and DON'T forget to complete the shoulder shapening.

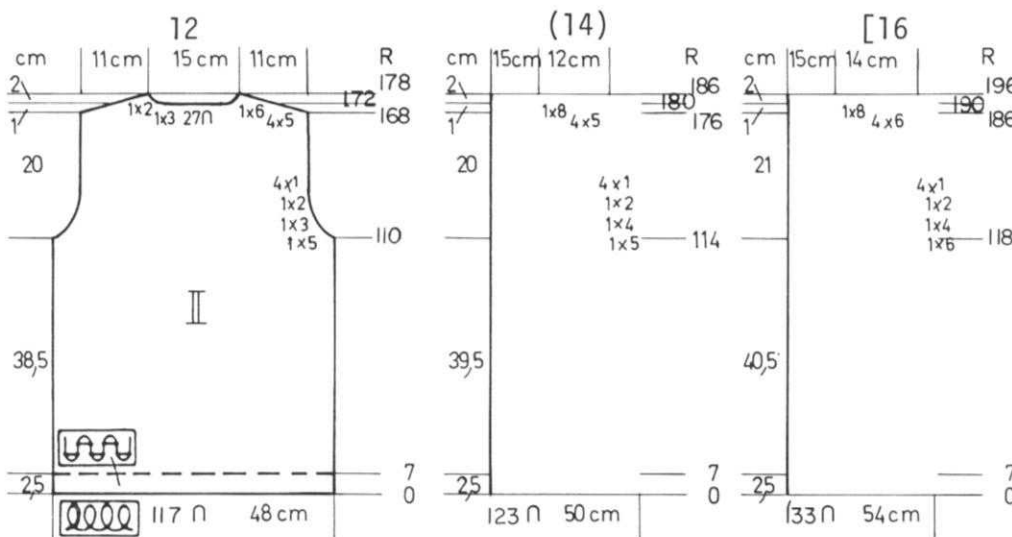

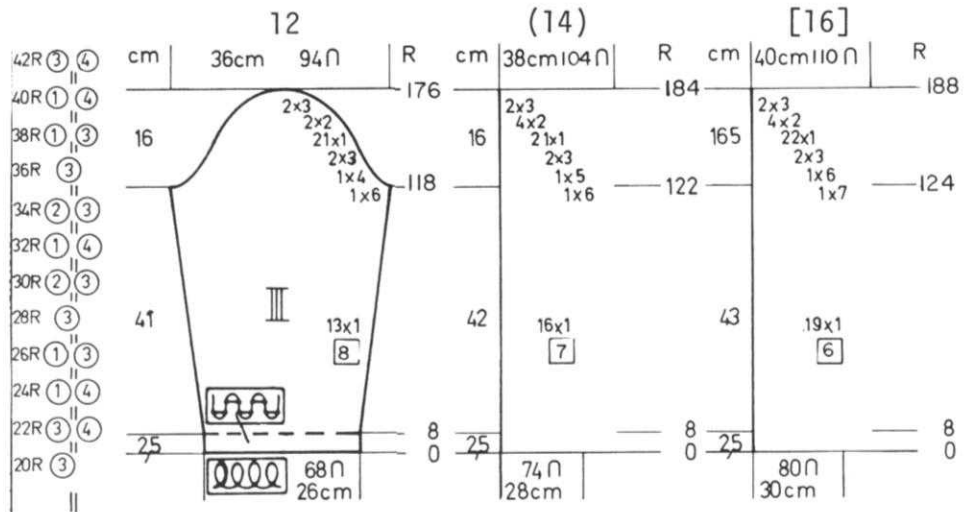
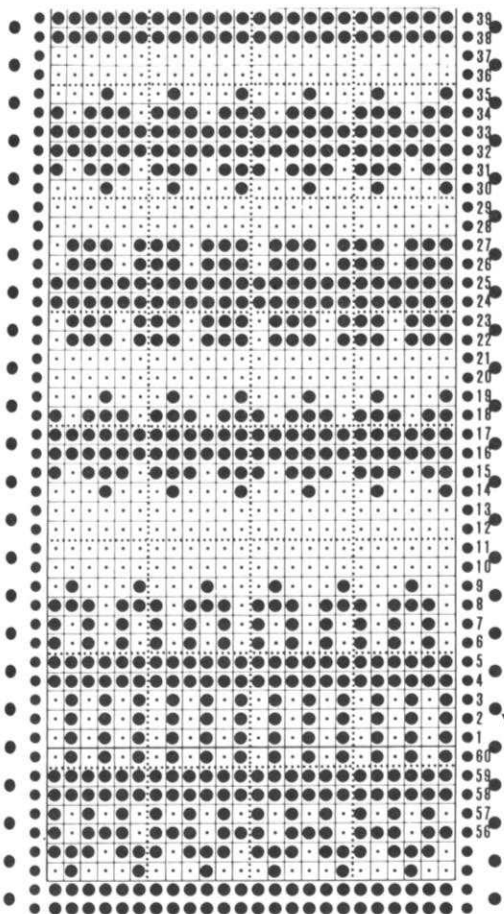

ARMBANDS: Make 2.
Cast on 100 sts. with color 1 and work 10 rows Ribbing. Bind off.

NECKBAND: Make 2.
Cast on 150 sts. with color 1 and work 10 rows Ribbing, increasing 1 st. for center neck every row. Move the end st. 1 needle out and pick up a stitch from row below and hang it onto empty needle. (Remember to keep in Ribbing Pattern—see Ribber Instruction Book).

SLEEVES: III
Cast on 68 (74) [80] sts. with color 1 and work 8 rows Ribbing. Continue in Ribbing Pattern with Eyelet Design same as back and front. ON EACH SIDE, increase 1 st. every 8th row 13x. (every 7th row 16x). [every 6th row 19x]. After Row 118 (122) [124], SHAPE CAP: ON EACH SIDE, bind off (AND WORK COLOR STRIPES AT THE SAME TIME AFTER ROW 123 (126) [129]). 6 sts. 1x, 4 sts. 1x, 3 sts. 2x, 1 st. 21x, 2 sts. 2x, 3 sts. 2x. (6 sts. 1x, 5 sts. 1x, 3 sts. 2x, 1 st. 21x, 2 sts. 4x, 3 sts. 2x). [7 sts. 1x, 6 sts. 1x, 3 sts. 2x, 1 st. 22x, 2 sts. 4x, 3 sts. 2x]. After Row 176 (184) [188], bind off the remaining sts.

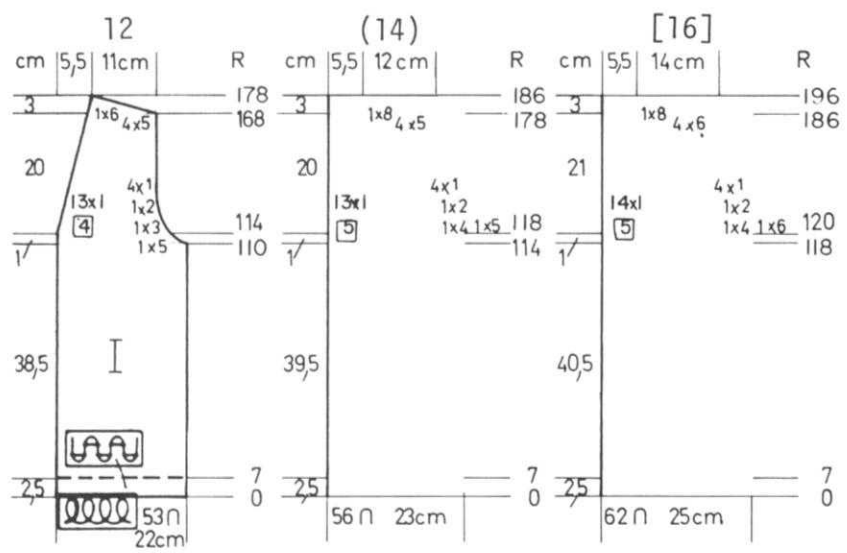

CARDIGAN FRONT: Make 1, reverse 1.
Cast on 53 (56) [62] sts. with color 1 and work 7 rows Ribbing. Continue in Ribbing Pattern with Eyelet Design same as the back. After Row 110 (114) [118], SHAPE ARMHOLE same as the back AND AT THE SAME TIME, SHAPE FRONT EDGE after Row 114 (118) [120]. ON NECK SIDE, decrease 1 st. every 4th row 13x. (every 5th row 13x). [every 5th row 14x]. AT THE SAME TIME, after Row 123 (126) [129], transfer the Rib sts. to main machine and work the color stripes in stockinette stitch same as the back. After Row 168 (178) [186], SHAPE SHOULDER same as the back.

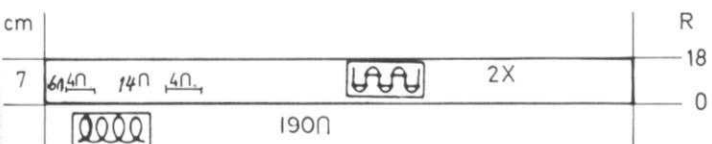

FRONT BANDS: Make 2, omit Buttonholes in 2nd section.

Cast on 190 sts. and work in Ribbing. After Row 9, MAKE 5 BUTTONHOLES beginning with needles 7 to 10, leave 14 sts. for space between and make buttonhole over the next 4 sts. etc. etc. until there are 5. After Row 18, bind off.

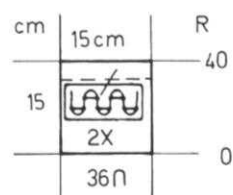

POCKETS: Make 2.
Cast on 36 sts. with color 1 and work 8 rows Ribbing. Continue in stockinette stitch with color stripes of *2 rows color 2, 2 rows color 3, 2 rows color 1 and REPEAT from * to Row 40. Bind off.

hp&o

MAN'S PULLOVER

SIZES: 40 (42) [44]
 YARN: Fortissima or Vienna
 GRAMS:
 color 1 350 400 450
 color 2 100 100 100
 color 3 100 100 100
 color 4 100 100 100

TENSION: 5 or 6

GAUGE: 13 sts. 13 1/2 rows = 5 cm (2")

Stockinette stitch with a Norwegian Design on back, front and sleeves.
 Punch your own Card. The bands are K1, P1 Ribbing.

FINISHING: See General Instructions.



SLEEVES: III

Cast on 74 (76) [80] sts. with color 1 and work 19 rows Ribbing. Continue in Stockinette and Norwegian Design as follows:
 Work 61 rows Stockinette stitch with color 1 then begin Norwegian Design - to Row 42 on Card, 4 rows Stockinette stitch then again Row 1 to 16 on Card. Finish in Stockinette stitch with color 1.
 AT THE SAME TIME, ON EACH SIDE, increase 1 st. every 6th row 16x for all sizes.

After Row 120, SHAPE CAP:

ON EACH SIDE, bind off

4 sts. 1x, 3 sts. 1x, 2 sts. 6x,
 1 st. 10x, 2 sts. 6x, 3 sts. 1x,
 4 sts. 1x, 5 sts. 1x.
 (4 sts. 1x, 3 sts. 1x, 2 sts. 6x,
 1 st. 10x, 2 sts. 6x, 3 sts. 1x,
 4 sts. 1x, 6 sts. 1x).
 [5 sts. 1x, 4 sts. 1x, 2 sts. 6x,
 1 st. 11x, 2 sts. 6x, 3 sts. 1x,
 4 sts. 1x, 5 sts. 1x].

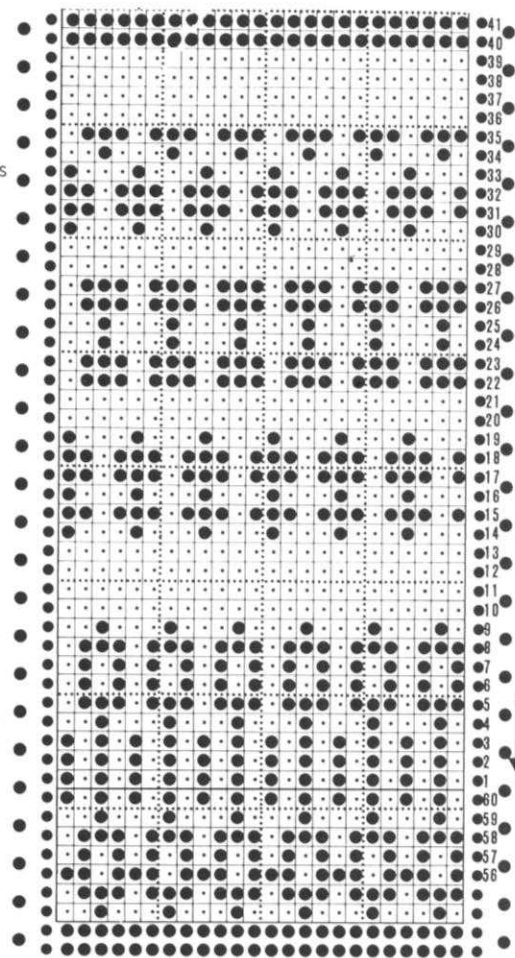

NECKBAND:

Cast on 140 sts. and work 40 rows Ribbing. Bind off.

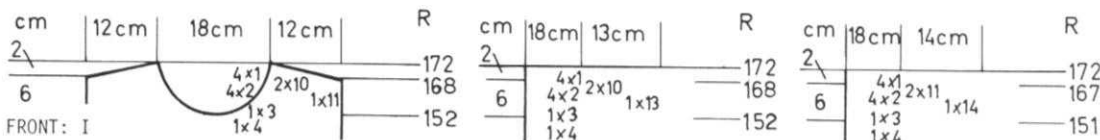
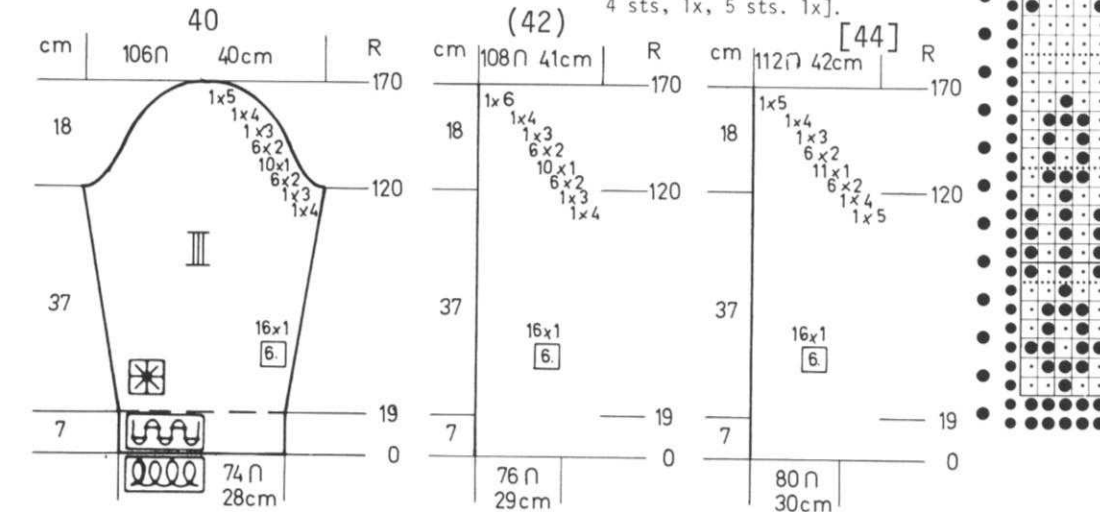

Work the front the same as the back to Row 152.
 SHAPE NECK: Bind off the center 10 sts., put the needles on the left into holding position and complete the right side first.
 *ON NECK SIDE, bind off for all sizes: 4 sts. 1x, 3 sts. 1x, 2 sts.

4x, 1 st. 4x.
 After Row 168, SHAPE SHOULDER SAME AS THE BACK.
 Bring the needles on the left into working position, knit 1 row in Pattern to the left side, turn the Row Counter back to 152 and complete the left half. Follow the instructions from *.

BACK: II

Cast on 142 (146) [152] sts. with color 1 and work 22 rows Ribbing. Continue in the NORWEGIAN DESIGN AS FOLLOWS: Work the 46 rows of Pattern twice, then Rows 1 to 16 on Card, then continue in Stockinette stitch with color 1.

After Row 108, SHAPE ARMHOLE: FOR ALL SIZES, ON EACH SIDE bind off.

4 sts. 1x, 3 sts. 1x, 2 sts. 2x, 1 st. 5x.

After Row 168, bind off the center 36 sts., put the needles on the left into holding position and complete the right side first.

*SHAPE SHOULDER AND NECK AT THE SAME TIME.

FOR SHOULDER, bind off 11 sts. 1x, 10 sts. 2x, (13 sts. 1x, 10 sts. 2x), [14 sts. 1x, 11 sts. 2x], FOR NECK, bind off 3 sts. 2x for all sizes.

Bring the needles on the left into working position, knit 1 row to the left side, turn the Row Counter back to 168 and complete the left half. Follow the instructions from *.

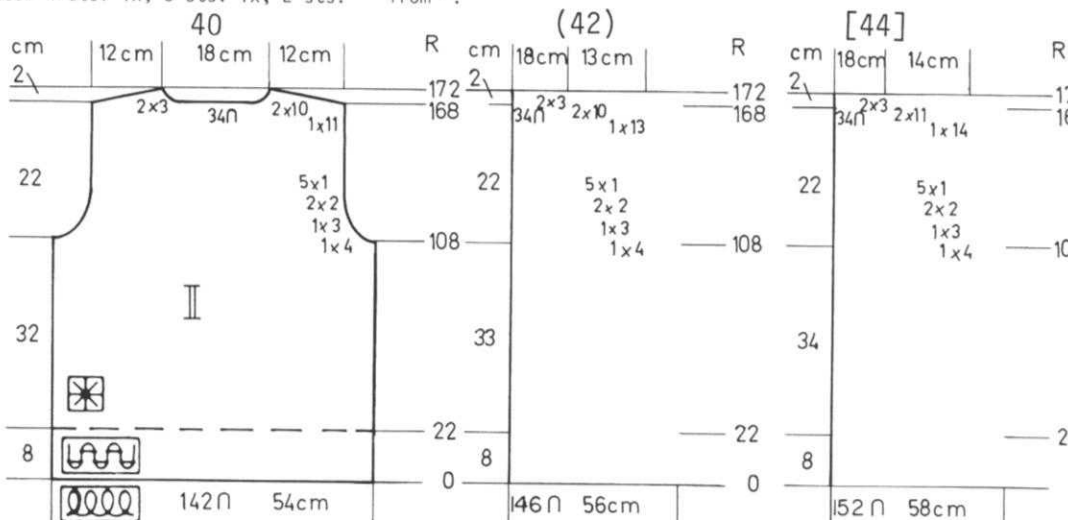



WOMAN'S DRESS & PANTS

SIZES: 10 (12)
 YARN:
 color 1 = KNITKING Acrylite
 color 2 = Mami Rex
 GRAMS:
 color 1 Approx 30 oz. both sizes.
 color 2 2 Spools
 TENSION: 3
 GAUGE: 16 sts. 30 rows = 5 cm (2")
 in Pattern.



A Tuck stitch Pattern with Ribber and Color Changer. Punch your own Card and push in BOTH TUCK Buttons. Change color EVERY 2 ROWS.

FINISHING: See General Instructions. You can sew all seams on a Sewing Machine. Turn under and hand hem all edges including the slit on dress. Make hem at top of pants and pull elastic through casing.

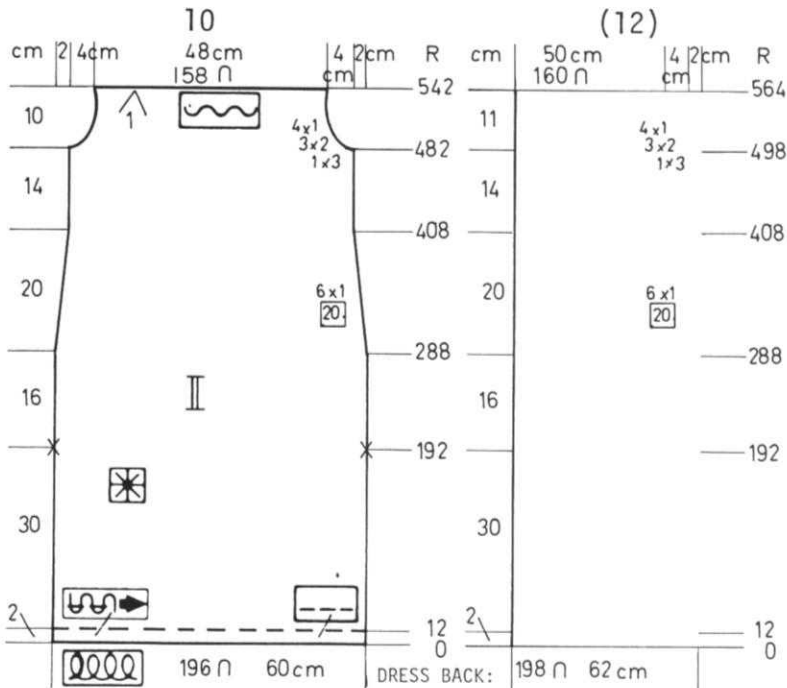

Cast on 196 (198) sts. with color 1 and work 12 rows Stockinette stitch. Continue in Pattern
 Mark Row 192 ON EACH SIDE, for slit.
 After Row 288, ON EACH SIDE, decrease 1 st. every 20th row 6x for both sizes.
 After Row 482 (498), SHAPE ARMHOLE: ON EACH SIDE, bind off 3 sts. 1x, 2 sts. 3x, 1 st. 4x for both sizes.
 After Row 542 (564), bind off the remaining sts.
 You must gather the top of dress to fit onto the shoulder Yoke insert.

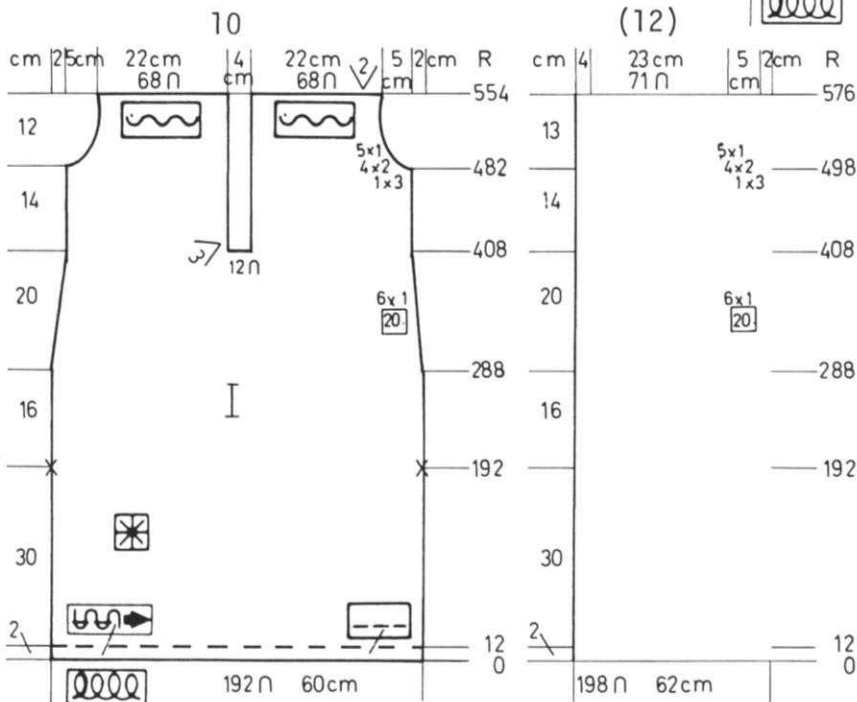

DRESS FRONT: I

Cast on 192 (198) sts. with color 1 and work 12 rows Stockinette stitch. Continue in Pattern
 After Row 192, Mark each side for slit.
 After Row 288, ON EACH SIDE, decrease 1 st. every 20th row 6x for both sizes.
 After Row 408, bind off the center 12 sts., put the needles on the left into holding position and complete the right side first.
 *After Row 482 (498), SHAPE ARMHOLE: Bind off 3 sts. 1x, 2 sts. 4x, 1 st. 5x for both sizes.
 After Row 554 (576), bind off the remaining sts.
 Bring the needles on the left into working position, knit 1 row in Pattern to the left side, turn the Row Counter back to 408 and complete the left half.
 Knit to Row 482 (498) then follow the instructions from *.

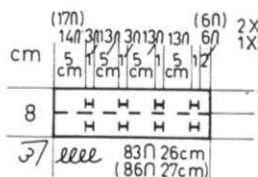

BUTTON BANDS: Make 2 but omit buttonholes in 2nd section.

Cast on 83 (86) sts. with color 1 and work Stockinette stitch

After Row 11, MAKE BUTTONHOLES: Counting from the RIGHT, make the first buttonhole over needles 7 to 9.
 *Skip the next 17, and make buttonhole over the next 3 needles. REPEAT from * for 4 buttonholes in all. You should end with 14 (17) sts. on the left side.
 After Row 33, make BUTTONHOLES over the same needles as before.
 After Row 44, bind off.

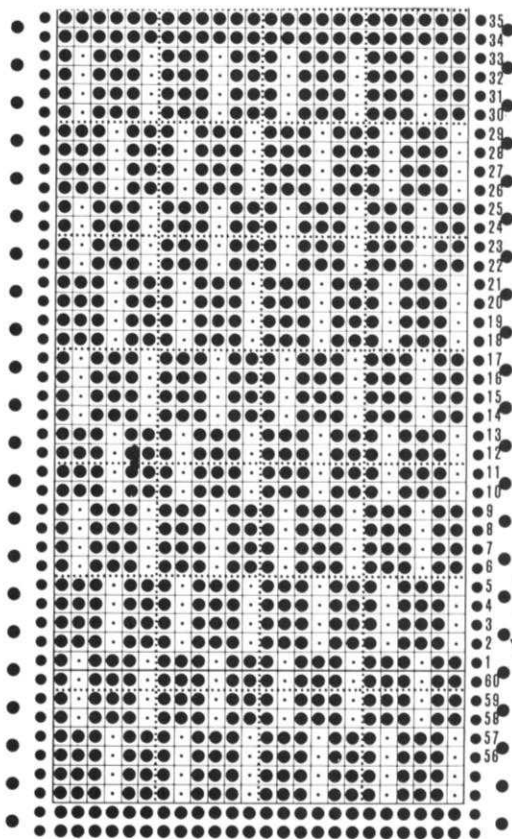

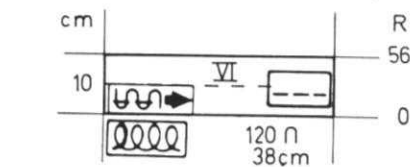
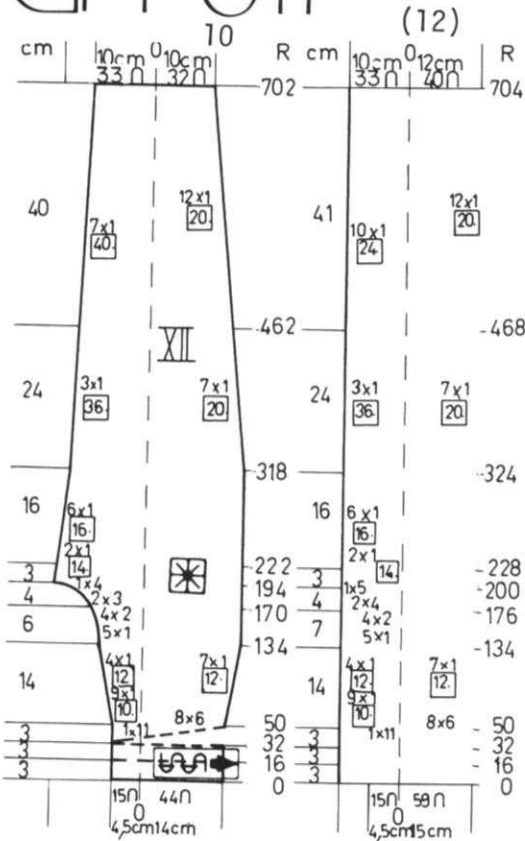

COLLAR BAND:

Cast on 120 sts. with color 1 and work 56 rows Stockinette stitch. Bind off.

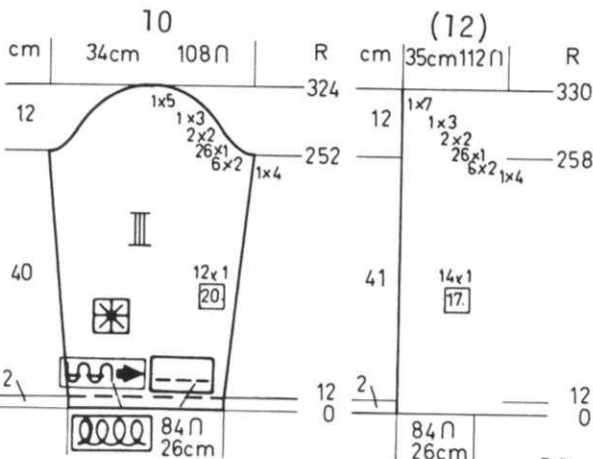

PANTS BACK: XII Make 1, reverse 1.

Cast on 59 (73) sts. with color 1 and work 32 rows Stockinette stitch. Continue in Pattern and work SHORT ROWS. ON OPPOSITE SIDE OF SLIDE, put into holding position, 11 sts. 1x, 6 sts. 8x. Bring all the needles back into working position. Please follow the different increases and decreases ON EACH SIDE as shown on the Chart for YOUR SIZE. After Row 702 (704), bind off the remaining stitches.

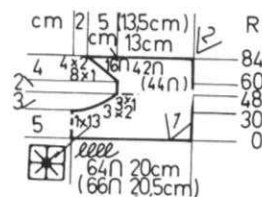

SHOULDER INSERT Make 1, reverse 1.

Cast on 64 (66) sts. with color 1 and work in Pattern. After Row 31, ON THE LEFT (right for 2nd section), bind off 13 sts. 1x, 2 sts. 3x, 1 st. 3x. After Row 60, ON THE LEFT (right) increase 1 st. 8x, cast on 2 sts. 4x. After Row 84, bind off.

SLEEVES:

Cast on 84 (84) sts. with color 1 and work 12 rows Stockinette stitch. Continue in Pattern. ON EACH SIDE, increase 1 st. every 20th row 12x. (every 17th row 14x). After Row 252 (258) SHAPE CAP: ON EACH SIDE, bind off 4 sts. 1x, 2 sts. 6x, 1 st. 26x, 2 sts. 2x, 3 sts. 1x, 5 sts. 1x. (4 sts. 1x, 2 sts. 6x, 1 st. 26x, 2 sts. 2x, 3 sts. 1x, 7 sts. 1x).

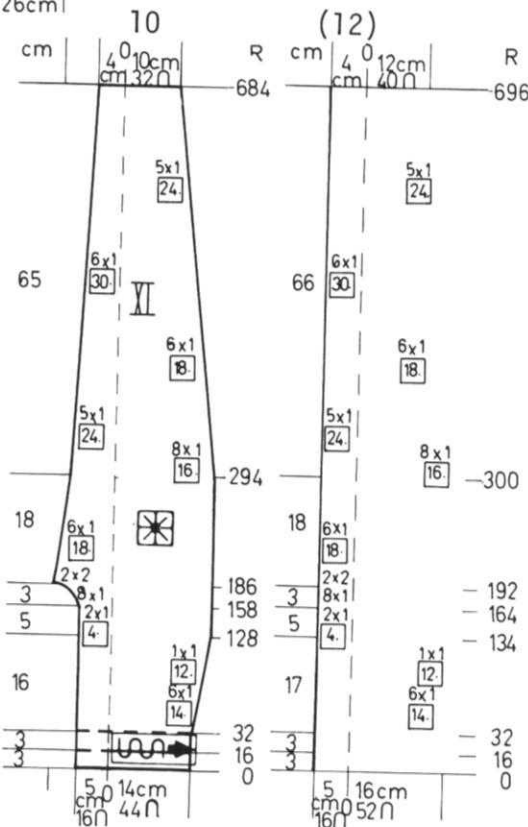

PANTS FRONT: XI Make 1, reverse 1.

Cast on 60 (68) sts. with color 1 and work 32 rows Stockinette stitch. Continue in Pattern. Please follow the different increases and decreases ON EACH SIDE as shown on the Chart for YOUR SIZE. After Row 684 (696), bind off the remaining stitches.

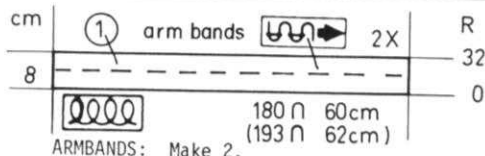

ARM BANDS: Make 2.

Cast on 180 (193) sts. with color 1 and work 32 rows Stockinette st. Bind off.

NECKBAND: Make 2.

Cast on 148 (152) sts. with color 1 and work 32 rows Stockinette st. Bind off.



WOMAN'S DRESS & TUNIC

SIZES: 10/12 (14)

YARN: Vienna

GRAMS: color 1 600 650

color 2 350 400

TENSION: 6 to 8 (Pattern)

3 to 5 (Stockinette)

GAUGE:

Pat. 13 sts. 42 rows = 5 cm (2")

Stock. 15 sts. 20 rows = 5 cm (2")

The Dress is Stockinette stitch. The Tunic is a Slip Stitch Pattern. Punch your own Card and push in BOTH PART BUTTONS. All bands are Stockinette stitch.

FINISHING: Dress: Sew right shoulder, then put on the Neckband. Leave left shoulder open. Work 1 row single crochet around shoulder opening then set in zipper. Hem edges and sew in sleeves.

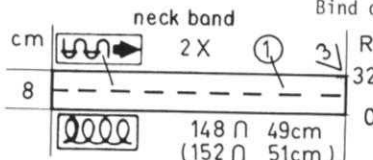

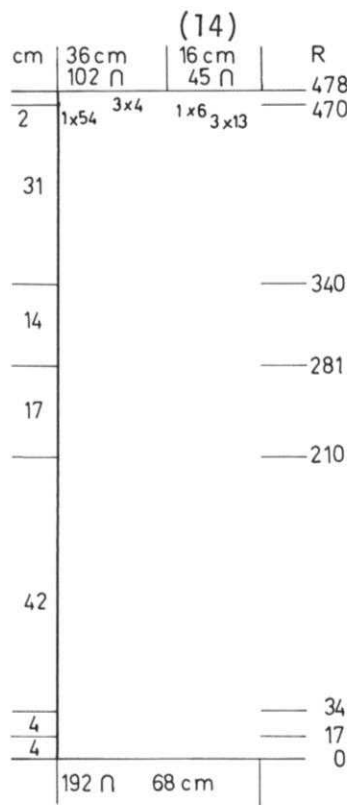
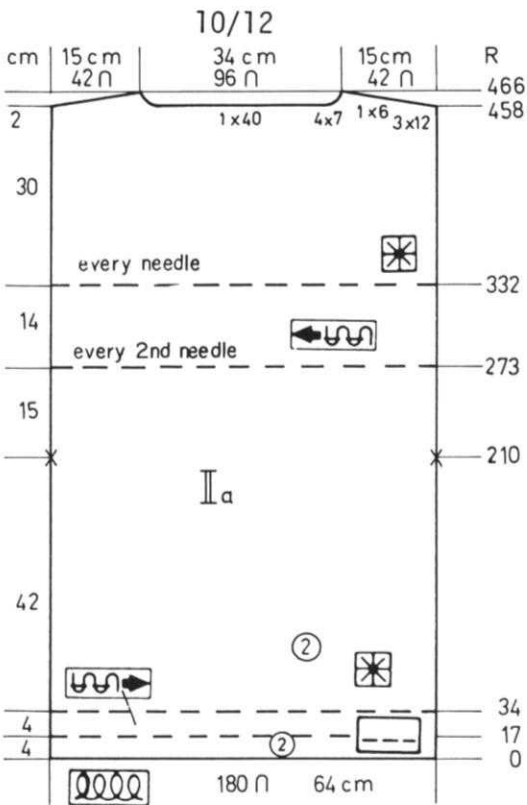

TUNIC BACK: IIa

Cast on 180 (192) sts. with color 2 and work 34 rows Stockinette stitch. Hang the hem (Tunic will be worn on purl side, with hems and bands on the knit side). Continue in Pattern. Knit to Row 210. Mark each side with a bit of contrast yarn. Knit to Row 273 (281). Transfer every other stitch to neighboring needle and put the empty needles to the out of work position. Continue in Stockinette stitch to Row 332 (340). Bring the empty needles into working position and continue in Pattern over all the needles. Knit to Row 458 (470). Bind off the center 40 (54) sts. put the needles on the left into holding position and complete the right side first. *SHAPE SHOULDER AND NECK AT THE SAME TIME. FOR SHOULDER, bind off 12 sts. 3x, 6 sts. 1x. (13 sts. 3x, 6 sts. 1x). FOR NECK, bind off 7 sts. 4x. (4 sts. 3x). Bring the needles on the left into working position, knit 1 row in Pattern to the left side, turn the Row Counter back to 458 (470) and complete the left half. Follow the instructions from *.

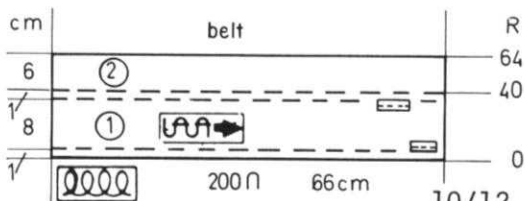

BELT:

Cast on 200 sts. with color 1 and work Stockinette stitch. After Row 40, change to color 2. After Row 64, bind off.

TUNIC FRONT: Ia

Work the front the same as the back to Row 332 (340). Put half the sts. on the left into holding position and complete the right side first. Bring all the empty needles into working position and continue in Pattern. *ON NECK SIDE, decrease 1 stitch every 2 rows 10x, every 3rd row 38x. (every 2 rows 15x, every 3rd row 36x). After Row 458 (470), SHAPE SHOULDER same as the back. Bring the needles on the left into working position, knit 1 row to the left side, turn the Row Counter back to 332 (340) and complete the left half. Follow the instructions from *.

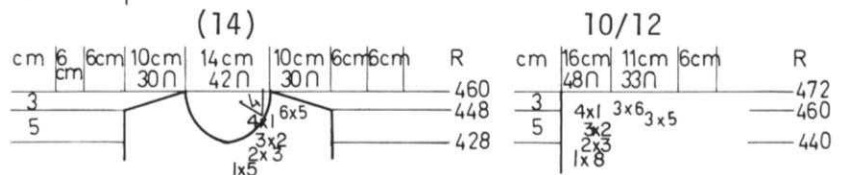
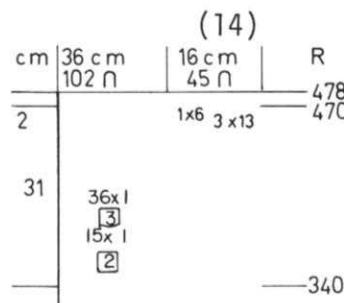
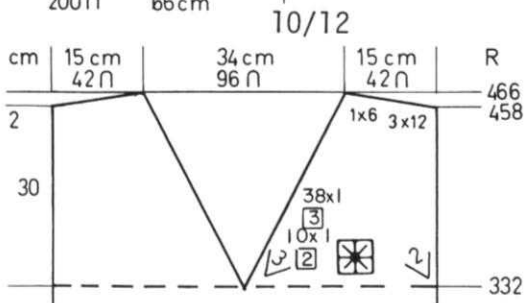

DRESS FRONT: I

Work the front the same as the back to Row 428 (440). Put half the sts. on the left into holding position and complete the right side first. *ON NECK SIDE, bind off 5 (8) sts. 1x then 3 sts. 2x, 2 sts. 3x, 1 st. 4x for both sizes. After Row 448 (460), SHAPE SHOULDER same as the back.

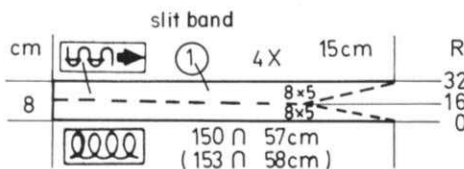

BANDS FOR SPLITS Make 4.

Cast on 150 (153) sts. with color 1 and work Stockinette stitch. ON EVERY 2nd ROW, on the right side, bind off 5 sts. 8x. After Row 16, on every 2nd row, cast on 5 sts. 8x. After Row 32, bind off.



DK 012

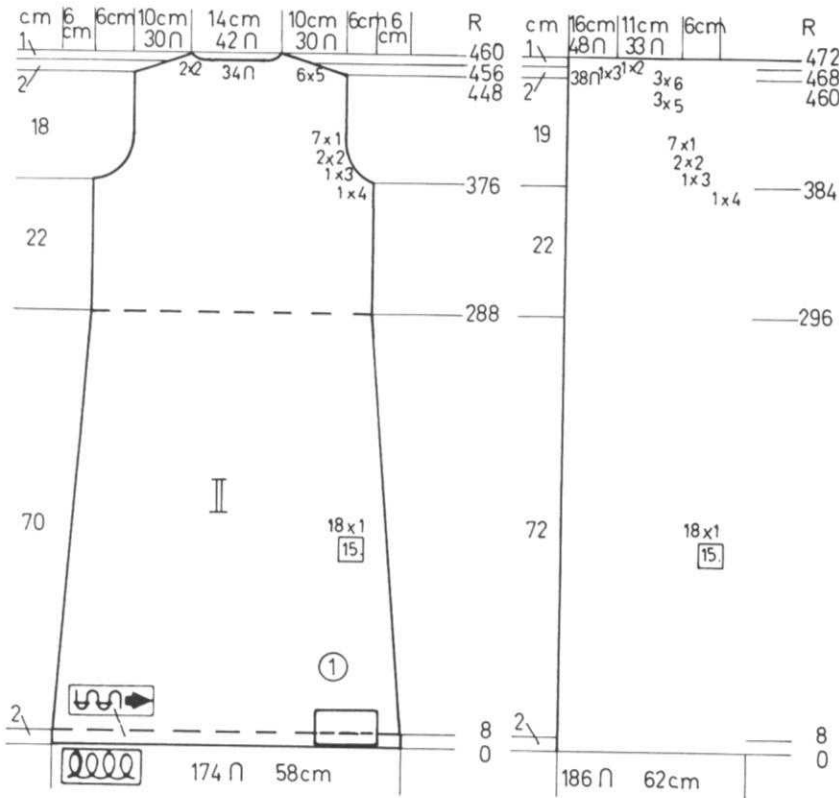

DRESS BACK: II

Cast on 174 (186) sts. with color 1 and work 16 rows Stockinette stitch. Hang the hem.

ON EACH SIDE, decrease 1 st. every 15th row 18x for both sizes.

After Row 288 (296), mark for waistline.

Knit to Row 376 (384).

SHAPE ARMHOLE: ON EACH SIDE, bind off 4 sts. 1x, 3 sts. 1x, 2 sts. 2x, 1 st. 7x for both sizes.

Knit to Row 448 (460).

SHAPE SHOULDER AND WATCH FOR NECK SHAPING.

FOR SHOULDER, bind off

5 sts. 6x,

(5 sts. 3x, 6 sts. 3x),

AT THE SAME TIME, after

Row 456 (468), bind off the center 34 (38) sts., put the needles on the left into holding position and complete the right side first.

ON NECK SIDE, bind off

2 sts. 2x.

(3 sts. 1x, 2 sts. 1x).

Bring the needles on the left into working position, knit 1 row to the left side, turn the Row Counter back to 456 (468) and complete the left half. Follow the instructions from * and don't forget to complete the shoulder shaping.

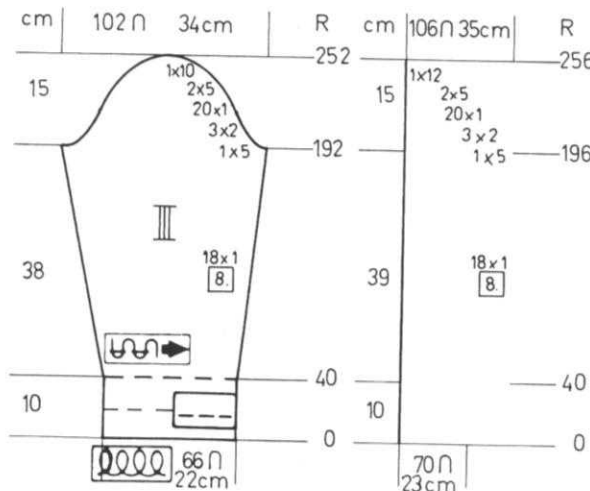
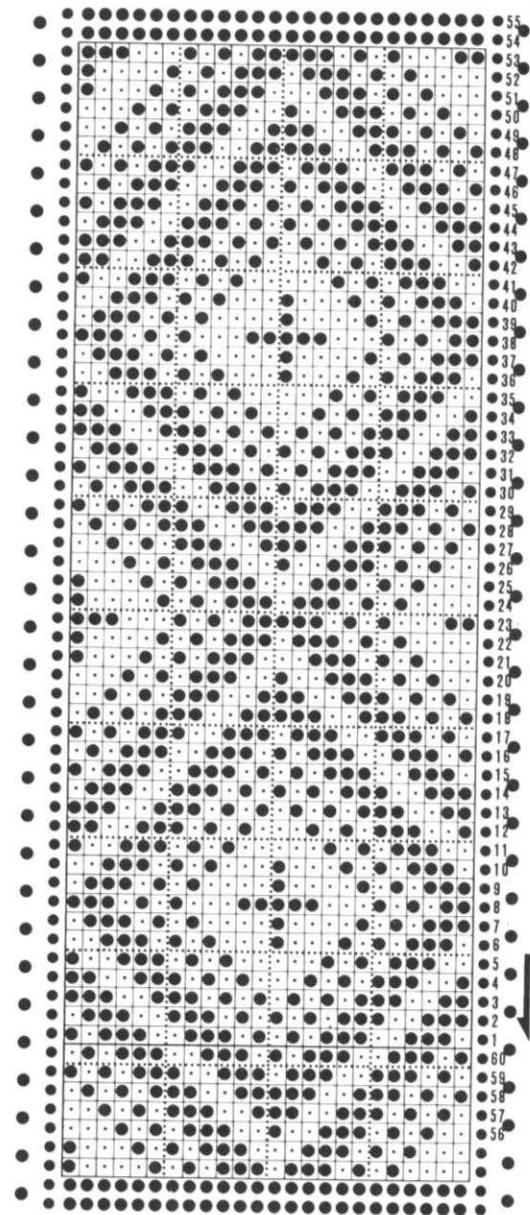

SLEEVES: III

Cast on 66 (70) sts. with color 1 and work Stockinette stitch.

After Row 40, hang the hem.

ON EACH SIDE, increase 1 st.

every 8th row 18x for both sizes.

After Row 192 (196), SHAPE CAP:

ON EACH SIDE, bind off

5 sts. 1x, 2 sts. 3x, 1 st. 20x,

5 sts. 2x, 10 sts. 1x.

(5 sts. 1x, 2 sts. 3x, 1 st. 20x,

5 sts. 2x, 12 sts. 1x).

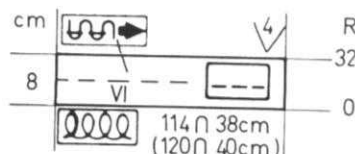

NECKBAND:

Cast on 114 (120) sts. with color 1 and work 32 rows Stockinette stitch. Bind-off.

dk 813

WOMAN'S JACKET & SKIRT

SIZES: 8/10 (12/14)
 YARN: Vienna
 GRAMS: Skirt 400 450
 Jacket 400 450
 TENSION: 5 to 7
 GAUGE: 15 sts. 20 rows = 5 cm (2")



FINISHING: See General Instructions.
 Skirt: Work 2 rows single crochet around lower edge of skirt. Fold band in half, gather skirt and fit to band. Insert elastic in casing.
 Jacket: Crochet 1 row single crochet around Yoke. Ease front section to yoke (see picture) Crochet the yoke to jacket front the right side for trim.
 Sleeve: At the underarm, leave 2" straight, then gather the rest across top of sleeve. Sew sleeve in then crochet across top of sleeve from the right side for trim (same as yoke).
 For Front edge and neckline, work 2 rows single crochet easing to keep front edge even. On 2nd row of crochet, on waistband, make 3 loops for button holes. Sew buttons to other side of waist.

Stockinette stitch with a Tuck Stitch for the Yoke. The Yoke is on the Purl side. Skirt and Jacket can be worn on knit or purl side.

8/10 (12/14)

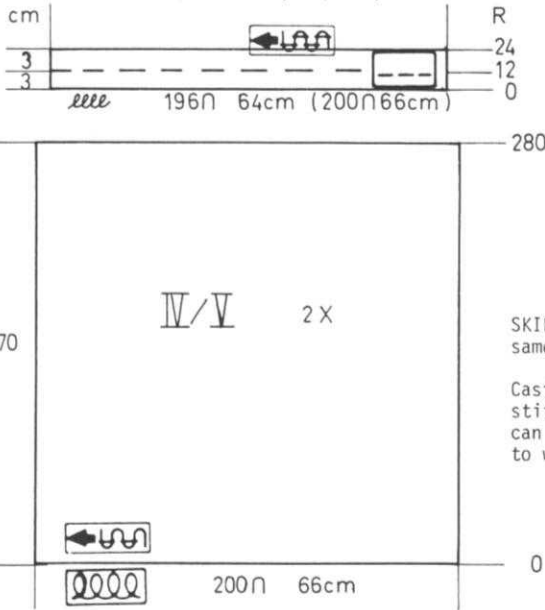

WAISTBAND OF SKIRT:

Cast on 196 sts. and work 24 rows Stockinette stitch. Bind off or hang the hem, then after sewing 1 seam of skirt, hang the stitches of the skirt to band, doubling the sts. as needed, then bind off.

SKIRT: IV/V Make 2 sections the same.

Cast on 200 sts. and work Stockinette stitch to Row 280. Bind off, or you can remove onto waste yarn and hang to waistband, decreasing to fit.

8/10

(12/14)

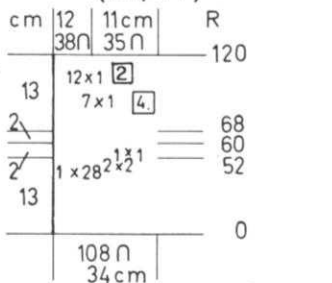
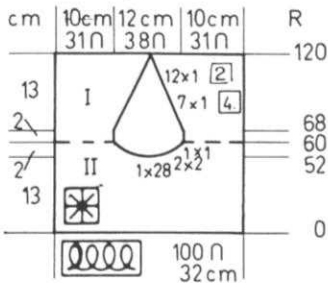

JACKET BACK: I BEGIN & END WITH CONTRAST WASTE YARN.

Cast on 200 sts. and work Stockinette stitch to Row 128 (132). Remove onto contrast waste yarn.

JACKET YOKE: II/I

Hang the open sts. of Jacket back onto the machine, decreasing to 100 (108) sts.
 Work Yoke in Pattern.
 After Row 52, bind off the center 23 sts., put the needles on the left into holding position and complete the right side first.
 *ON NECK SIDE, bind off 2 sts. 2x, 1 st. 1x.
 After Row 68, ON NECK SIDE, increase 1 st. every 4th row 7x, every 2nd row 12x.
 After Row 120, remove onto waste yarn.
 Bring the needles on the left into working position, knit 1 row in Pattern to the left side, turn the Row Counter back to 52 and complete the left half. Follow the instructions from *.

WAISTBAND FOR JACKET BACK:

Hang the open sts. of waist edge back onto the machine decreasing to 140 (144) sts. Remove waste yarn. Knit 1 row, then transfer every other stitch to the Ribber and work 56 rows K1, P1 Ribbing. Bind off.

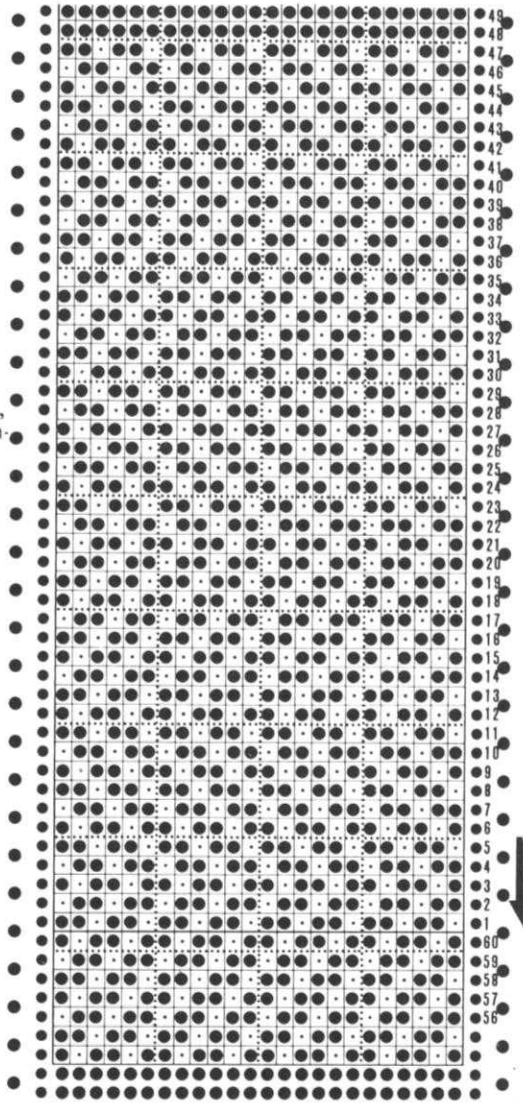

DK 813

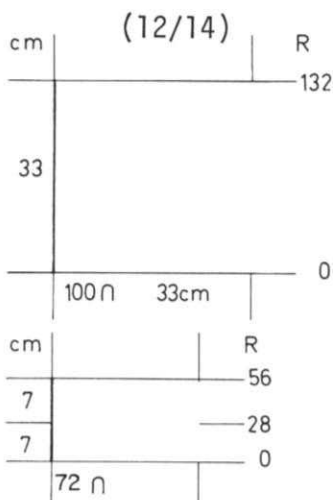
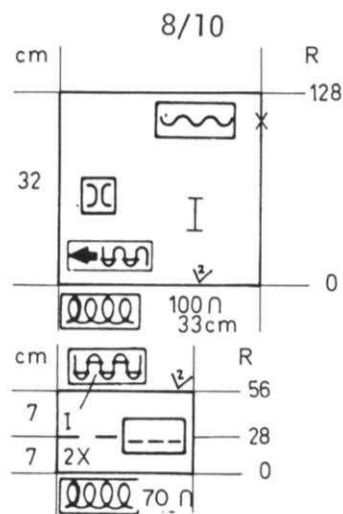

JACKET FRONT: I BEGIN & END WITH WASTE YARN. Make 2.

Cast on 100 sts.
Work Stockinette stitch to Row 128 (132).
Remove onto contrast waste yarn.
Hang the open sts. to one side of front yoke, decreasing to 50 sts.
Remove waste yarn and bind off.
REPEAT for other side of FRONT.

WAISTBAND FOR JACKET FRONT:

Hang the open sts. of waist edge onto the machine, decreasing to 70 (72) sts. Remove waste yarn. Knit 1 row then transfer every other stitch to the Ribber and work 56 rows K1, P1 Ribbing. Bind off.

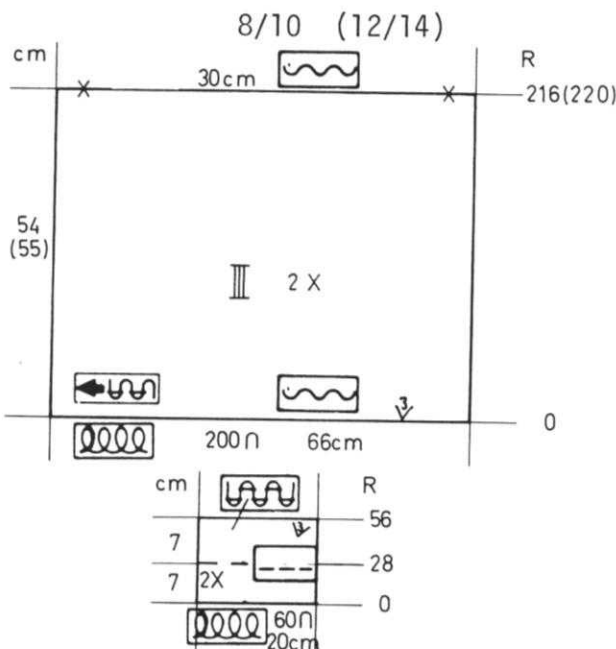

SLEEVE: III Make 2.
BEGIN & END WITH WASTE YARN.

Cast on 200 sts. and work Stockinette stitch to Row 216 (220).
Remove onto contrast waste yarn.

CUFF: Make 2

Hang the open sts. of the sleeve back onto the machine, decreasing to 60 sts. Remove the waste yarn. Knit 1 row, then transfer every other stitch to the Ribber and work 56 rows K1, P1 Ribbing. Bind off.

converta tape

CONVERTA TAPES ARE HERE AGAIN!!! That marvelous Accessory the CONVERTA TAPE has been unavailable for two years... and we have them again, made in Germany to the original design... Using the Tape makes the charting of garments to size ten times easier... Just make a sample swatch, set the Tape to its Stitch (or Row) Gauge, measure the person and you get an instant reading of stitches or rows needed... Use a Converta Tape also to immediately convert KNITTING MAGAZINE and other patterns for use with thinner or thicker yarns.

NO knitter should be without a KNITTING CONVERTA TAPE...

Calif. residents add Sales Tax.
Shipping Costs \$1.25

\$15.95

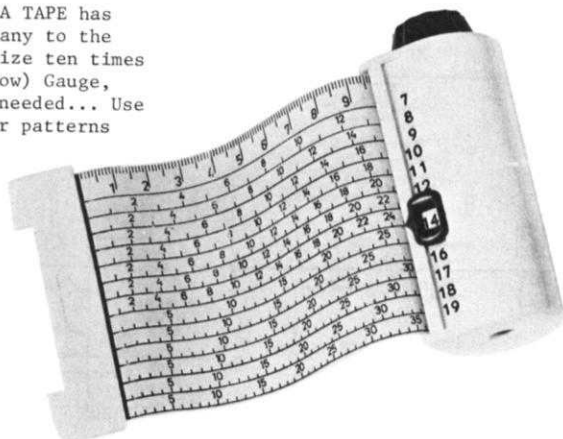

Order direct from KNITTING - 1128 Crenshaw Blvd., Los Angeles, California 90019



KNITTING NEWS

PRACTICAL KNITTING HINTS

TO USE THE KNITLEADER WITH THE JUMBO CN-9N KNITTER

You must ALWAYS make a sample swatch FIRST using the yarn, tension number and Stockinette stitch or Pattern Stitch that you will use for knitting your garment.

Cast on 40 sts. with contrast waste yarn. Knit 8 to 10 rows Stockinette stitch. Change to the yarn and Pattern you will use for your garment (Stockinette stitch or Pattern Stitch). Knit 15 rows. Mark the 11th stitch ON EACH SIDE of 0 with a bit of contrast waste yarn (tie it into the stitch). Knit 15 rows. Knit 8 to 10 rows with contrast waste yarn and remove the work from the machine by running the carriage across without yarn.

With your KNITLEADER RULER, measure the sts. (20) between the marked stitches on your swatch. Take the Numbered Strip for your JUMBO KNITTER that is CLOSEST to the measurement... for instance, the 20 stitches might measure 11 cm... so you would use the Number 11.1 Strip... Put it on the machine, centering the 0 on the Strip with 0 on the machine.

To double check your stitch gauge, use your sample swatch and place it on the chosen strip beginning at 0 and the 20 marked stitches in the center of swatch should measure from 0 to 20 on the Strip.

Measure the 30 rows between the waste knitting. Set the ROW REGULATOR to the centimeters and millimeters measurement of the 30 rows (USING YOUR KNITLEADER RULER). For instance, the measurement might be 10 cm (centimeters) and 5 mm (millimeters).

Set BOTH ROW COUNTER TRIPS TO WORKING - so that the Plastic Sheet will MOVE TWICE for EVERY ROW.

Now you are ready to knit your garment, following the shapings which you have drawn on your Knit-leader Sheet.

CLOSED CAST ON

You can make a closed cast-on without using waste knitting by making use of your Cast-on Comb. This is the way it is done.

Hang the Cast-on Comb onto the machine then bring the required number of needles into holding position. Cast on over the shanks of the needles by winding the yarn as though you were forming an 'e' - from left to right. As you are casting on, be sure the stitches are pushed up close to the machine against the gate pegs.

Turn the tension down 1 or 2 numbers and knit 1 row from right to left. Drop the Cast-on Comb and turn the tension to garment tension then continue with your knitting. Hang weights onto the Cast-on Comb to hold the knitting down.

SEWING ZIPPERS INTO A GARMENT

A Jacket type zipper needs to have a firm base for sewing the zipper to garment. Work 1 row of single crochet from the WRONG side of garment, going into every other stitch and keeping the work flat and

even. If you are working REVERSE single crochet at the edge, work one row single crochet from WRONG side then turn the garment to the right side and work reverse single crochet from LEFT to RIGHT.

Pin the zipper in place, easing the knitting to fit. With matching thread, and working on the right side, back stitch the zipper in place.

DUPLICATE STITCH

To work duplicate stitch as shown for DK 801 in this issue of KNITTING MAGAZINE, follow the instructions and diagrams as given below.

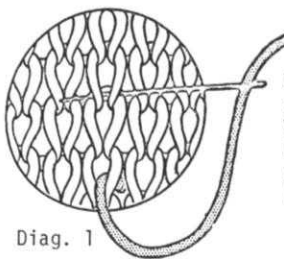

Diag. 1

Work from bottom to top. Bring needle through center of st. from WRONG SIDE of work to RIGHT side. Insert needle from right to left under the two strands of next st. (Diag. 1). Draw yarn through.

Insert needle back into same st. where needle was brought out of beginning (Diag. 2). *Bring needle up through center of st. just completed.



Diag. 2

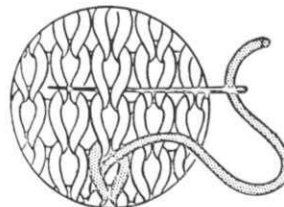

Diag. 3

Insert needle from right to left under the two strands of next st. (Diag. 3). Draw yarn through. Insert needle back into same st. where needle was brought out. REPEAT from * for specified amount of sts. At top of row, weave yarn back down on wrong side under sts. just made, then bring needle out in position to work the first st. of next row.

DISCOUNTED YARN KITS FOR THIS ISSUE

The Yarn Kits for this issue of KNITTING MAGAZINE are available at special discounts to our subscribers and the prices are only good until the next issue of the magazine. Be sure to give alternate colors.

KK 791 - Yarn: Sport Weight
SIZES: 8/10 (12/14)
NO KIT AVAILABLE

HP 792 - Yarn: Vienna
SIZES: 34 (36) [38]
Regular Price \$32.90 \$32.90 \$35.25
Sale Price 26.32 26.32 28.20
Shipping 1.85 1.85 1.85

HP 793 - Yarn: KNITTING Acrylite
 SIZES: 38 (40) [42]
 Regular Price \$28.50 (approx.30 oz. all sizes)
 Sale Price 22.80
 Shipping 1.85

DK 794 - Yarn: Fortissima or Vienna
 SIZES: 10/12 (14)
 Regular Price \$25.85 \$28.20
 Sale Price 20.68 22.56
 Shipping 1.85 1.85

DK 795 - Yarn Micaela
 SIZES: 10/12 (14/16)
 Regular Price \$16.03 \$18.32
 Sale Price 12.82 14.70
 Shipping 1.85 1.85

KK 796 - Yarn: Euro Sport (plus thin yarn of
 your choice - not included in Kit)
 SIZES: 2 (4) [6]
 Regular Price \$10.50 \$10.50 \$12.25
 Sale Price 8.40 8.40 9.80
 Shipping 1.85 1.85 1.85

HP 797 - Yarn: Knitting Worsted
 SIZES: 38/40 (42)
 NO KIT AVAILABLE

DK 798 - Yarn: Euro Sport
 SIZES: 10/12 (14/16)
 Regular Price \$19.25 \$21.00
 Sale Price 15.40 16.80
 Shipping 1.85 1.85

KK 799 - Yarn: Euro Sport (plus a loopy, fluffy
 yarn of your choice for colors
 2, 3 & 4 - not included in Kit).

SIZE: 2/3
 Regular Price \$14.00
 Sale Price 11.20
 Shipping 1.85

KK 800 - Yarn: Euro Sport
 SIZES: 4/6 (8/10)
 Regular Price \$28.00 \$29.75
 Sale Price 22.40 23.80
 Shipping 1.85 1.85

DK 801 - Yarn: Heavier than Knitting Worsted
 Size: 12/14
 NO KIT AVAILABLE

KK 802 - Yarn: Micaela
 SIZE: 2 to 3 years
 Regular Price \$13.74
 Sale Price 10.99
 Shipping 1.85

DK 803 - Yarn: Fortissima
 SIZES: 8 (10) [12]
 Regular Price \$23.22 \$25.80 \$28.38
 Sale Price 18.58 20.64 22.70
 Shipping 1.85 1.85 1.85

DK 804 - Yarn: Fortissima
 SIZES: 7/8 (10) [12]
 Regular Price \$18.06 \$18.06 \$20.64
 Sale Price 14.45 14.45 16.51
 Shipping 1.85 1.85 1.85

HP 805 - Yarn: Fortissima
 SIZES: 36 (38) [40]
 Regular Price \$25.80 \$28.38 \$30.96
 Sale Price 20.64 22.70 24.77
 Shipping 1.85 1.85 1.85

DK 806 - Yarn: Capriccio + Micaela
 SIZES: 8/10 (12)
 Regular Price \$67.66 \$76.25
 Sale Price 54.13 61.60
 Shipping 2.50 2.50

DK 807 - Yarn: Euro Sport
 SIZES: 5/6 (7/8)
 Regular Price \$22.75 \$24.50
 Sale Price 18.20 19.60
 Shipping 1.85 1.85

DK 808 - Yarn: Euro Sport
 SIZES: 7/8 (10/12)
 Regular Price \$26.25 \$31.50
 Sale Price 21.00 25.20
 Shipping 1.85 1.85

DK 809 - Yarn: Micaela or Vienna
 SIZES: 12 (14) [16]
 Regular Price \$29.77 \$32.06 \$36.64
 Sale Price 23.82 25.65 29.31
 Shipping 1.85 1.85 1.85

HP 810 - Yarn: Fortissima or Vienna
 SIZES: 40 (42) [44]
 Regular Price \$28.20 \$30.55 \$32.90
 Sale Price 22.56 24.44 26.32
 Shipping 1.85 1.85 1.85

DK 811 - Yarn: KNITTING Acrylite plus Mami Rex
 SIZES: 10 (12)
 Regular Price \$35.28 (approx.30 oz.+ Mami Rex
 Sale Price 28.22 for both sizes)
 Shipping 2.50

DK 812 - Yarn: Vienna
 SIZES: 10/12 (14)
 Regular Price \$44.65 \$49.35
 Sale Price 35.72 39.48
 Shipping 1.85 2.50

DK 813 - Yarn: Vienna
 SIZES: 8/10 (12/14)
 Regular Price \$37.60 \$42.30
 Sale Price 30.08 33.84
 Shipping 1.85 1.85

COLOR CHANGES FOR DK 804 - On page 28.

Begin here:
 *2 rows color 1+2 1 row color 1+2
 2 rows color 1+3 1 row color 1+3
 1 row color 1 1 row color 1
 1 row color 1+4 2 rows color 1+4
 1 row color 1 1 row color 1+2
 1 row color 1+3 2 rows color 1+4
 2 rows color 1+2 1 row color 1
 1 row color 1+3 2 rows color 1+3
 1 row color 1 2 rows color 1+2
 2 rows color 1+4 2 rows color 1+3
 1 row color 1+2 1 row color 1
 2 rows color 1+4 3 rows color 1+4
 1 row color 1 3 rows color 1+3
 3 rows color 1+3 2 rows color 1
 1 row color 1 2 rows color 1+4
 3 rows color 1+4 2 rows color 1
 1 row color 1 2 rows color 1+3
 1 row color 1+3 REPEAT FROM *
 continue top right/

GOOD NEWS FOR CANADIAN READERS

We have been told by many customers in Canada that Machines and Accessories being shipped to them are getting through without payment of duty.

If you decide to order merchandise at our SPRING SALE, you should first check with your nearest Customs Duty Office to confirm that you will not be charged duty.

This is your opportunity to order the fantastic KH 840 or the KH 120 or a JUMBO Knitter or a BELLINKY... all at tremendous discounts. You can use VISA or MASTER CHARGE but all payments must be in U.S. Dollars. Study the literature included in this magazine and place your order early.



...it's new from Knitking
The KH-120/258
fine needle
knitter

**Especially for
fine yarn...**
(from crochet thread to
to sport yarn)

With the new
LACEMAKER that makes
exquisite fine lace as
well as
standard lace.

The **KH-120** has Twin Yarn
Feeders and Push Button Pattern
Selection for an unlimited
number of fancy stitches.

Ideal knitter for large people.

With 258 needles, the **KH-120** will
knit 32 inches wide when knitting 8 stitches
per inch... 200 needle machines can only
knit 25 inches wide at the same stitch gauge.

You can use your **KNITLEADER** with the **KH-120**.
There is a 258 needle **RIBBER ATTACHMENT** available.
You can actually rib with a fine yarn over as many as
516 needles for a superfine rib knit. You can also knit
tubular using 516 needles.

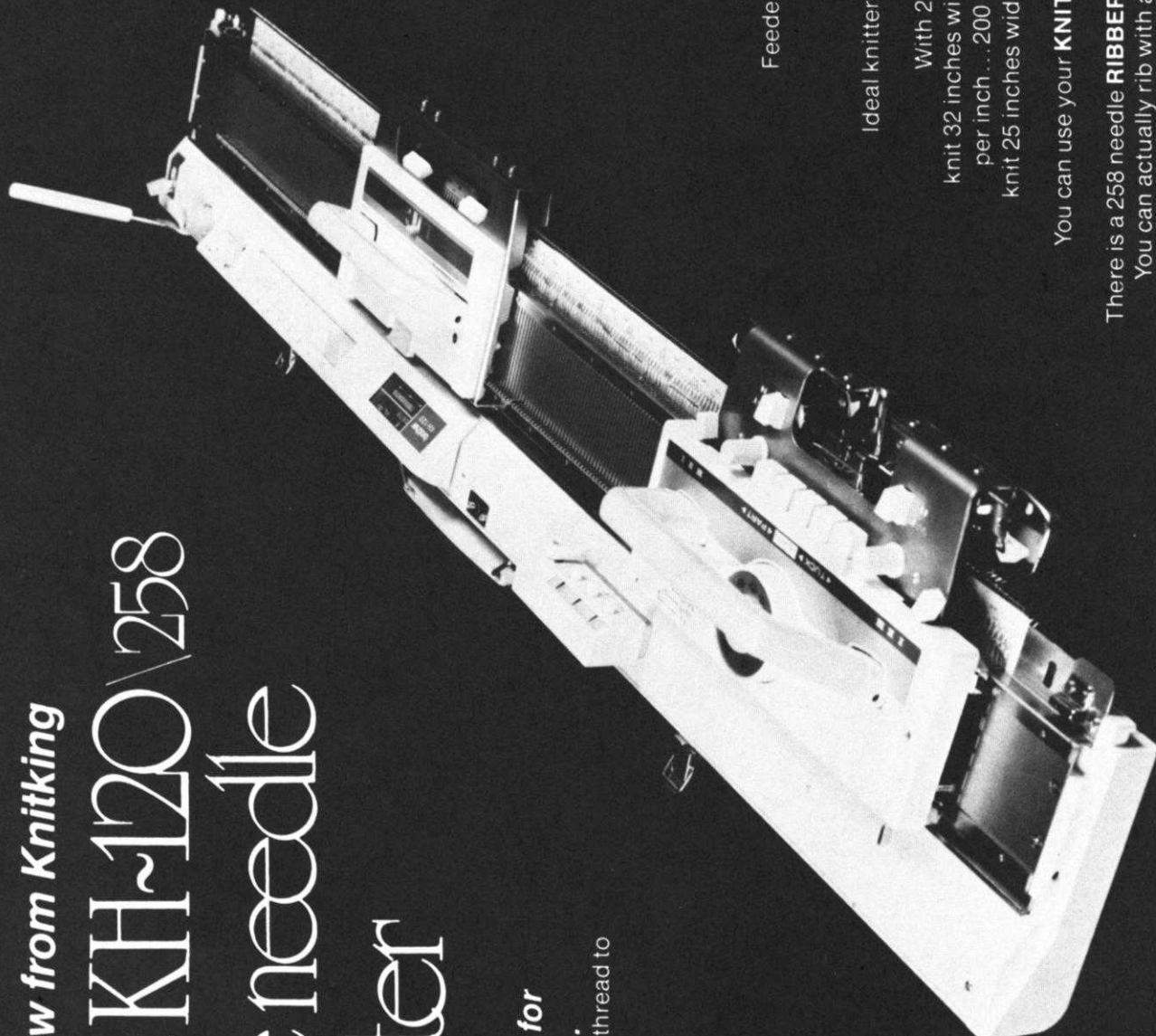

New! New! New! from KNITKING

intarsia pattern charts

AND CHARTING ACCESSORY

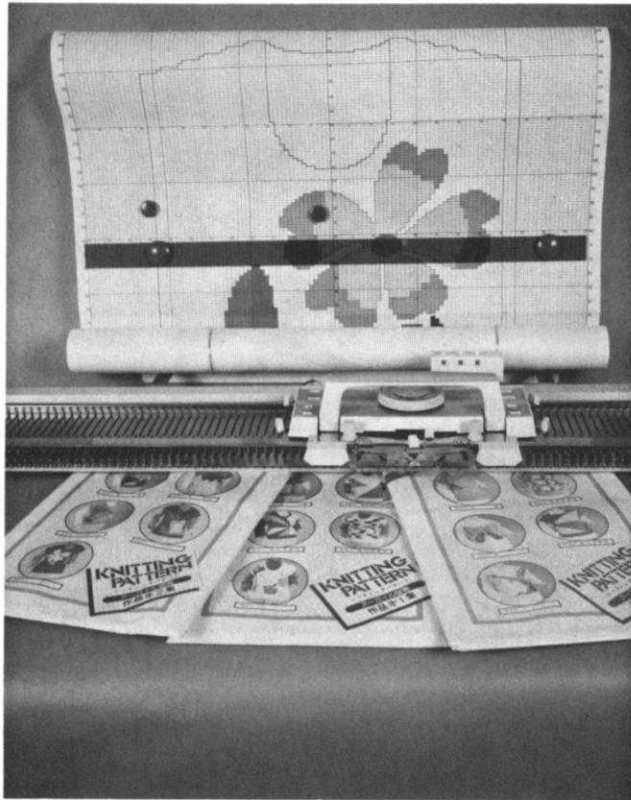

Made specifically for the JUMBO Knitter, these new Charts can also be transferred to your Knitleader and reproduced with the new INTARSIA FEEDER on the KH 840...

The CHARTING ACCESSORY fits the JUMBO Knitter... It is simple and efficient to use... The plastic row Ruler is held in place with Magnetic Buttons so that you always know exactly where you are.

There are three sets of Patterns with five to a set. Every Pattern is a Pullover but you can use the wonderful selection of Intarsia Designs on any garment...Skirts, Dresses, Coats, etc... Also included in our package deal is a packet of blank Charts so that you can draw your own patterns.

SPECIAL INTRODUCTORY PRICE
FOR EVERYTHING... \$49.95

Calif. residents add Sales Tax.
Shipping costs \$2.25

READY NOW ...

KNITKING MAGAZINE BOUND VOLUME NO. 14...

HARD BOARD COVER...

APPROXIMATELY 180 PATTERNS...

WITH COMPLETE INSTRUCTIONS...

PRICE...\$15.95

SHIPPING COSTS... 1.75



ORDER DIRECT FROM KNITKING - 1128 Crenshaw Blvd.
Los Angeles, Calif. 90019

dk 795



A fashion advertisement featuring a man with light hair, wearing a dark green ribbed zip-up sweater over a light-colored collared shirt and light grey trousers. He is sitting on a dark wooden chair, leaning forward with his hands near his chest. The background is a blurred stone wall. The image is framed by a white decorative border with floral motifs in the corners. The text 'hp 792' is printed in a white, stylized font in the upper right area.

hp 792

dk 803

dk 804

hp 805



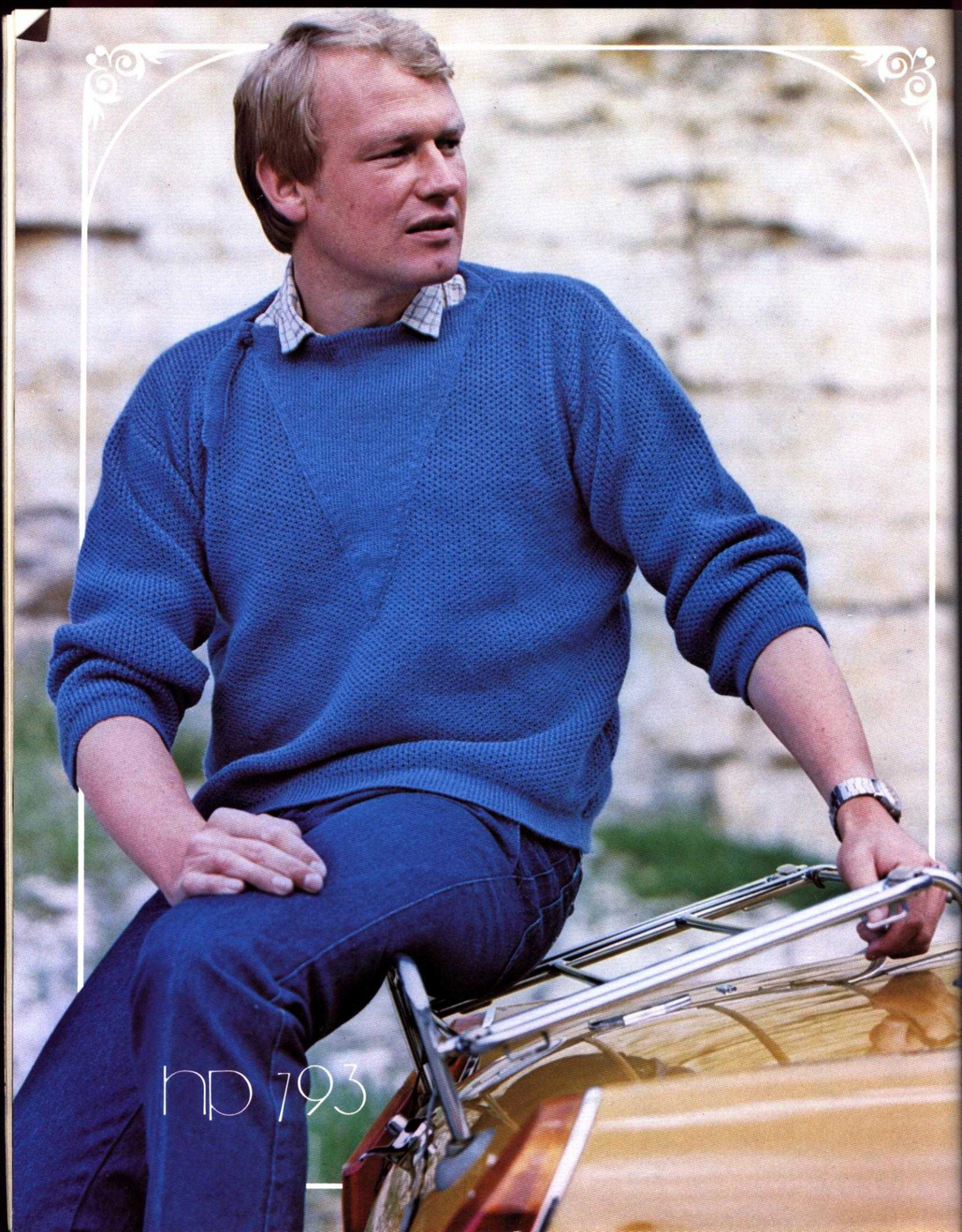

hp 793

hp 197

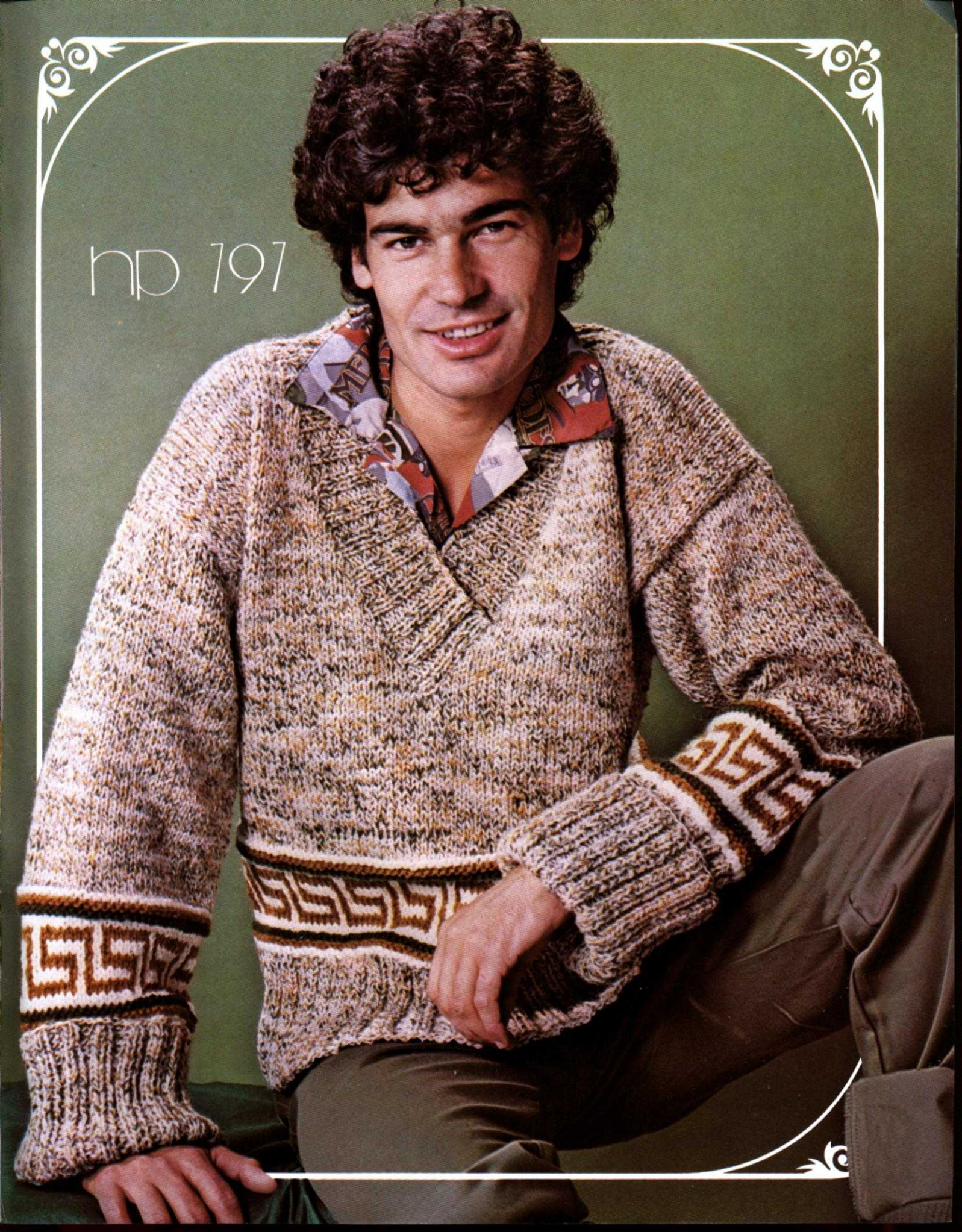



KK 799

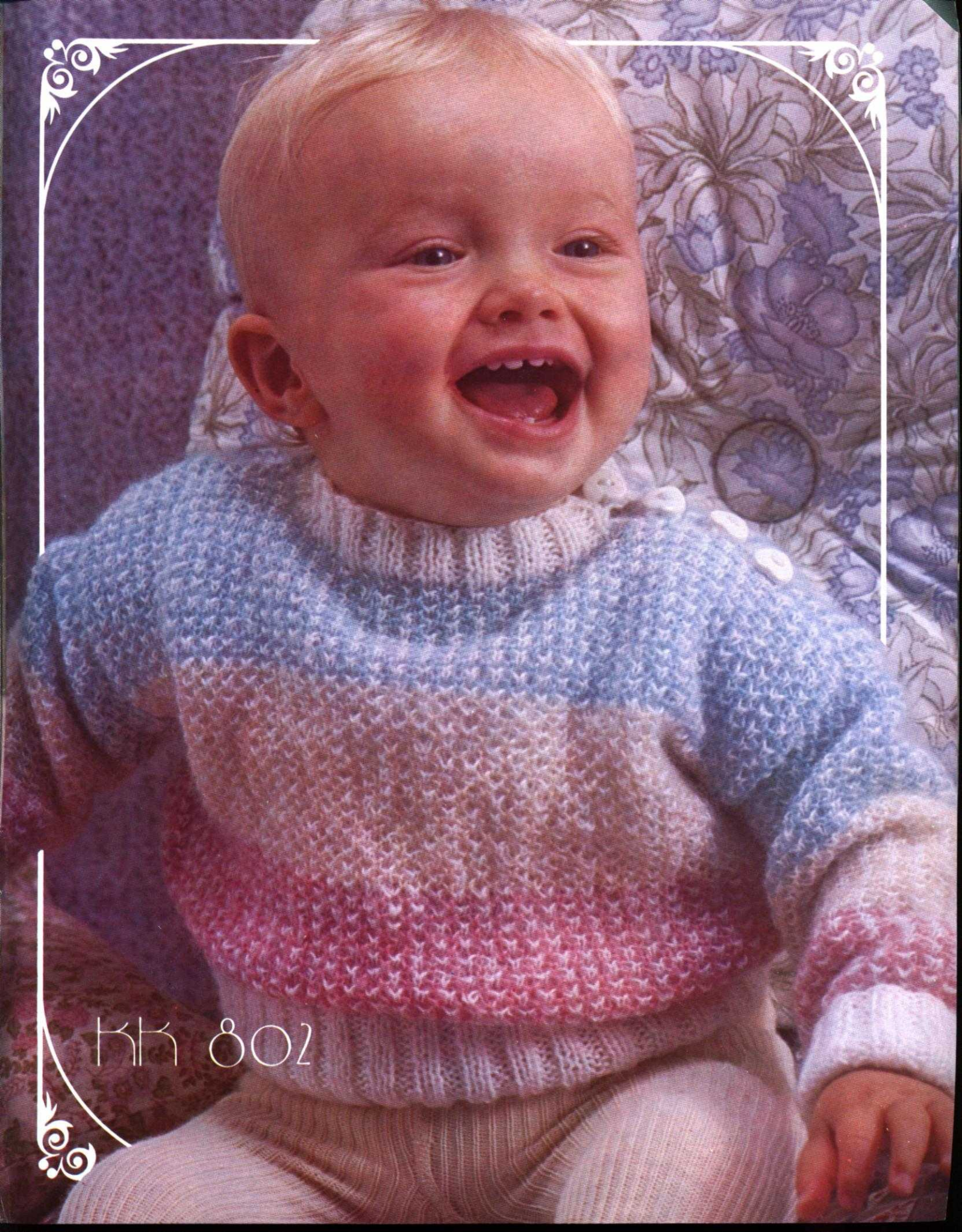

КК 802

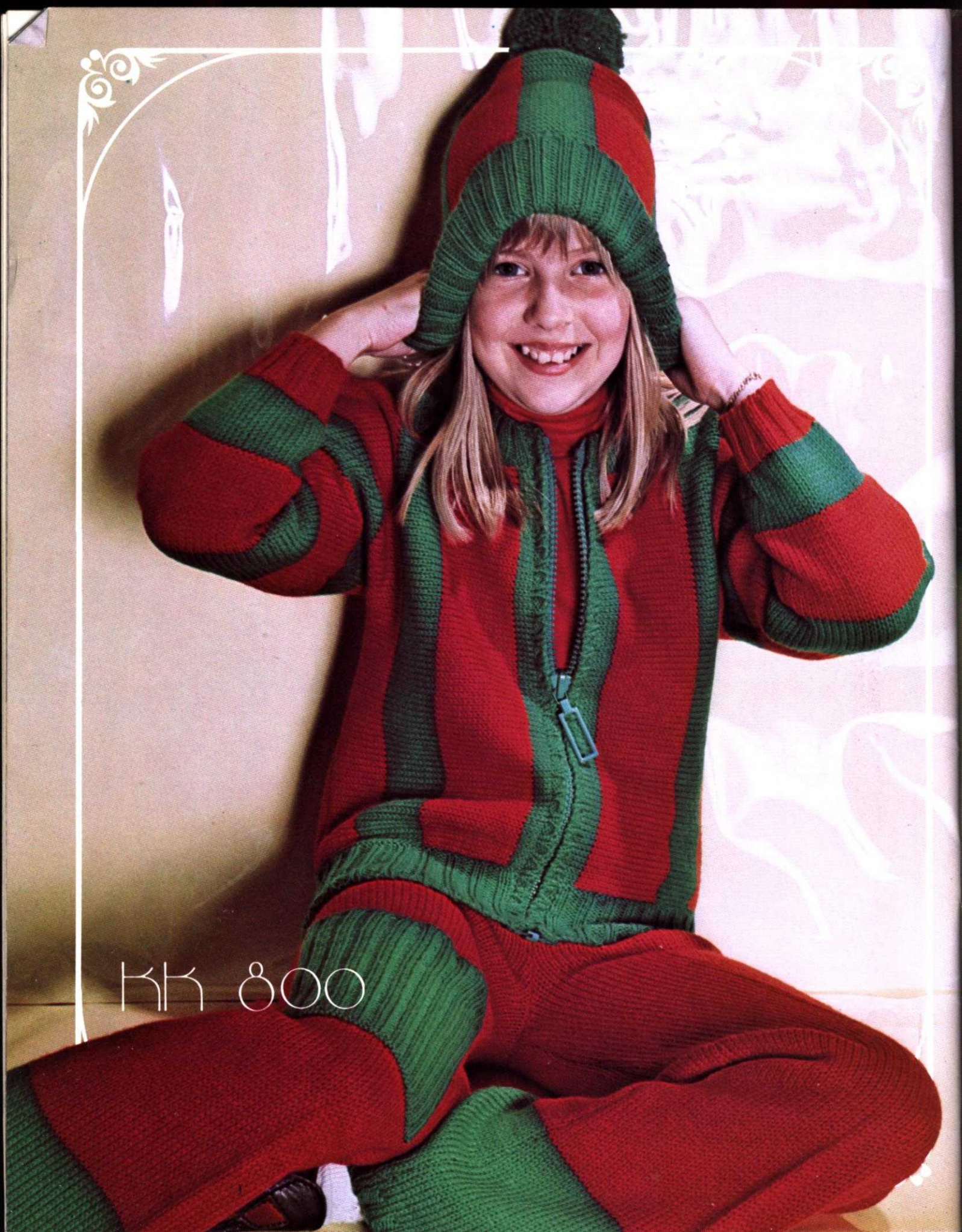

KK 800

KK 796

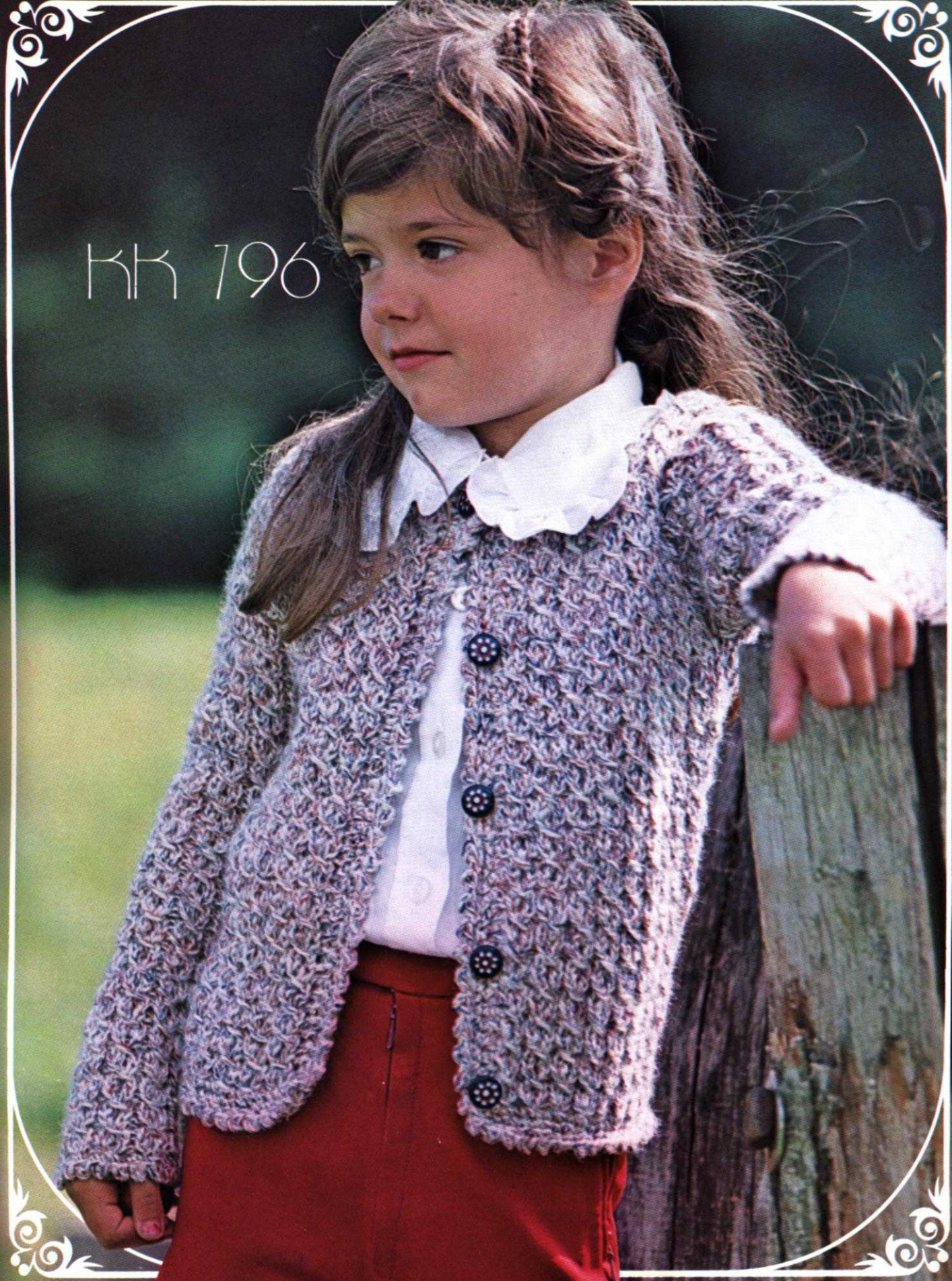



KK 791