

**HOW TO USE
YOUR MACHINE**





① LADY'S SWEATER
(Page 16)
② LADY'S SWEATER
(Page 28)
③ LADY'S CARDIGAN
(Page 40)

HOW TO USE YOUR MACHINE

1. SETTING UP YOUR MACHINE	2
2. MACHINE	3
Needle	
3. ACCESSORIES	3
4. BEFORE KNITTING	4
RELEASING AND SETTING THE CARRIAGE	4
NEEDLE POSITIONS	4
TENSION DIAL	5
CHANGE LEVER AND HOLDING CAM LEVERS	5
PREPARING THE YARN	6
CAST-ON COMB	6
NEEDLE PUSHER	6
GATE PEG	7
5. START TO KNIT (Tension Swatch 1)	8
Tension Switch 2	15
1 LADY'S SWEATER (CREW NECK)	16
2 LADY'S SWEATER (V-NECK)	28
3 LADY'S CARDIGAN (V-NECK)	40

PATTERN KNITTING

1. PLATING	48
2. INTARSIA KNITTING	49
3. PULL-UP STITCH PATTERN (TUCK STITCH PATTERN)	51
4. SKIP STITCH PATTERN	52
5. MULTI-COLOUR SKIP STITCH PATTERN	52
6. LACE PATTERN	53
7. KNIT & PURL STITCH PATTERN	54
8. CABLE STITCH PATTERN	55

BASIC TECHNIQUES FOR MAKING GARMENTS

1. HOW TO USE THE TRANSFER TOOL	56
2. HOW TO USE THE LATCHET TOOL	57
3. DECREASING STITCHES	58
4. INCREASING STITCHES	59
5. PARTIAL KNITTING	60
6. WASTE KNITTING	62
7. BACK STITCH	62
8. REMOVING THE WASTE KNITTING	62
9. CASTING-OFF	63
10. BINDING OFF FOR FINISHED EDGE	64
11. PICKING UP THE STITCHES	65
12. PICKING UP THE SIDE EDGE STITCHES	65
13. BINDING OFF ON THE MACHINE TO JOIN THE KNITTING	65
14. SEAMING	66
15. FINISHING	66

USEFUL HINTS (PROBLEMS DURING KNITTING)

1. WHAT TO DO WHEN YOU CANNOT KNIT SMOOTHLY	67
2. HOW TO PICK UP A DROPPED STITCH	67
3. WHAT TO DO IF YOU MAKE MISTAKES AS YOU KNIT (EXCEPT INTARSIA)	68
■ IF THE CARRIAGE SHOULD JAM	68
■ IF YOU WANT TO UNRAVEL SOME KNITTING	70
4. WHAT TO DO IF YOU MAKE MISTAKES AS YOU KNIT (INTARSIA)	71
■ IF THE CARRIAGE SHOULD JAM	71
■ IF YOU WANT TO UNRAVEL SOME KNITTING	71

LOOKING AFTER YOUR MACHINE

1. REPLACING A NEEDLE	72
2. CLEANING AND MAINTENANCE	72

HOW TO REPLACE YOUR MACHINE

HOW TO USE YOUR MACHINE

1 SETTING UP YOUR MACHINE

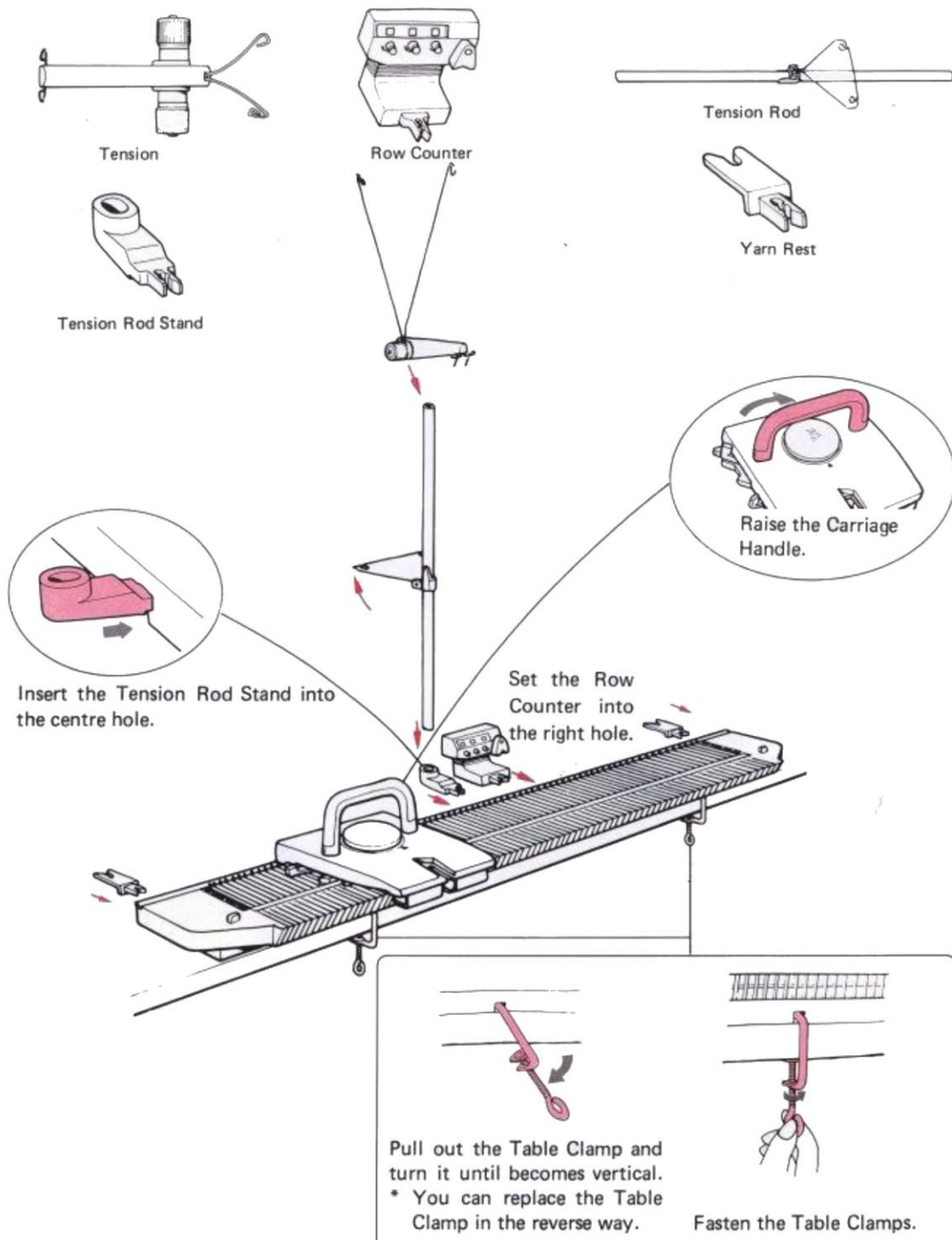

2 MACHINE

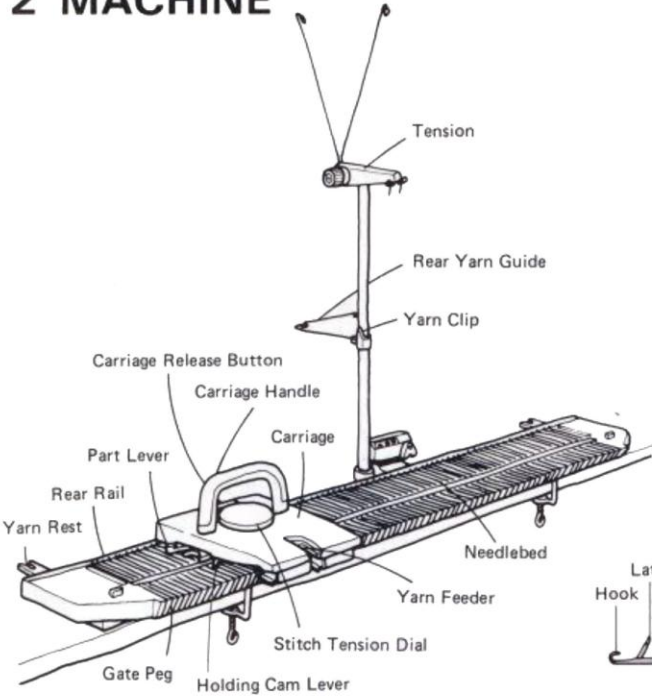

NEEDLE

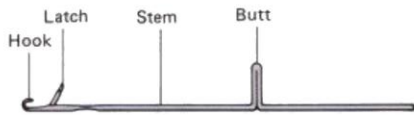

3 ACCESSORIES

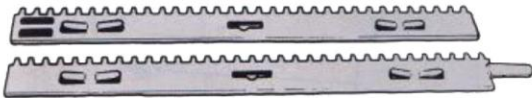

Cast-on Comb

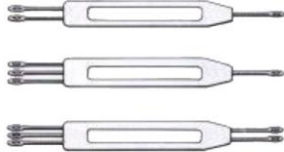

Transfer Tools

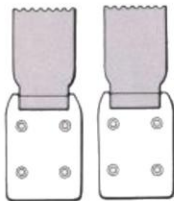

Claw Weights

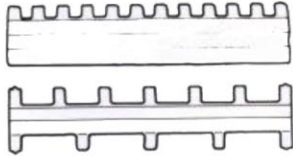

Needle Pusher



Latchet Tool



Tapestry Needle



Silicone Oil

TENSION DIAL

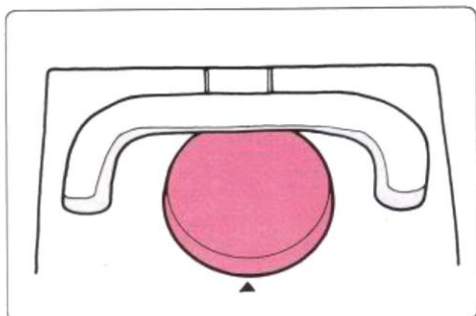

This dial is graduated from 0 to 10. With this dial you can alter the size and tension of your stitches. 0 is the tight tension (i. e. the smallest stitch) and 10 is the loosest tension (i. e. the largest stitch). You should adjust the dial to a higher or lower number according to the thickness and type of yarn you are using.



Lower tension knitting Higher tension knitting

Weight of yarn	Recommended Tension Dial Setting
380 m/100 g	1–3
220 m/100 g	4–6
160-m/100 g	7–9

As there are so many different types of yarn, it is impossible for us to tell you which Tension Dial Setting you should use. You must decide for yourself which is correct for your yarn by working sample swatches. Use the information above as a rough guide only.

PART LEVERS AND HOLDING CAM LEVERS

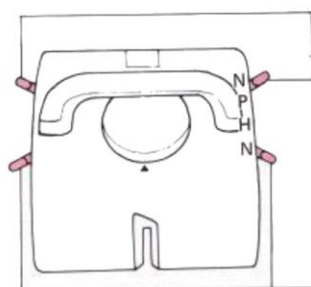

Part Lever

N For normal knitting. When the Part Lever is set at N, needles at B, D, and E positions are knit.

P For skip stitch pattern and multi colour skip stitch pattern. When the Part Lever is set at P, needles at D and E positions are knit.

Holding Cam Lever

N For normal knitting. When the Holding Cam Lever is set at N, needles at B, D, and E positions are knit.

H To knit neck line, or for partial knitting and pull-up stitch pattern. When the Holding Cam Lever is set at H, needles at B and D positions are knit.

The right Lever works when the Carriage moves rightward.
The left Lever works when the Carriage moves leftward.

PREPARING THE YARN

When you are new to machine knitting, you are advised to start with new yarn which is smooth and of reasonably good quality.

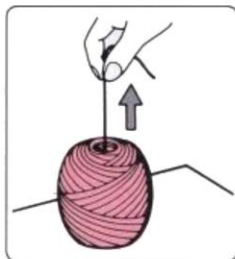

Pull the yarn from the center of a ball.

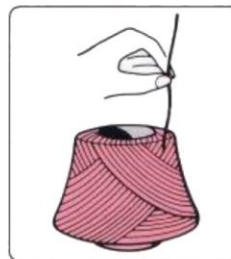

Coned yarn is available from some shops, this has been specially wound ready for machine knitting. Use the yarn from the outside of the cone.

You had better rewind the yarn using the wool winder, if you can get it.

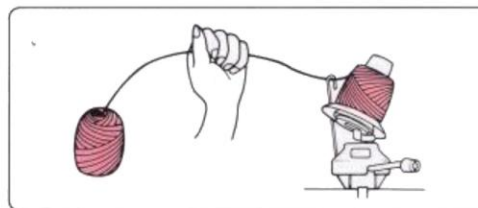

CAST-ON COMB

If you are using more than 65 needles you will need both pieces of the Cast-on Comb, push them together as illustrated.

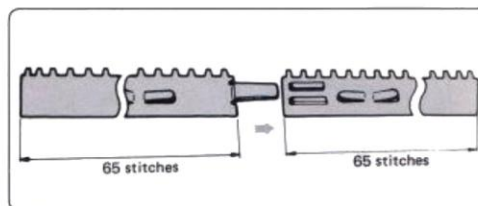

RUBBER WHEELS

Before you knit, always make sure that the centre two rubber wheels are in non-working position and outer ones are in working position. Only when knitting intarsia, put the rubber wheels into reverse positions (refer to page 49).

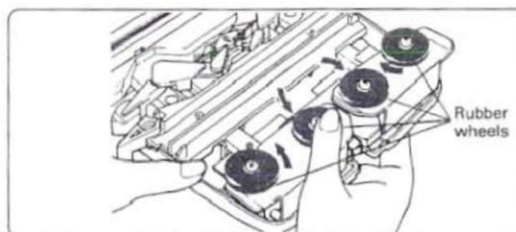

GATE PEG

You need to choose the proper Gate Pegs according to the yarn (see the chart on page 5).

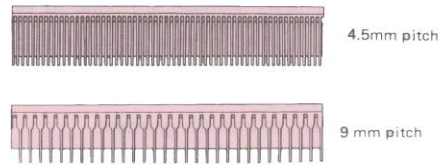

Changing the Gate Pegs

1

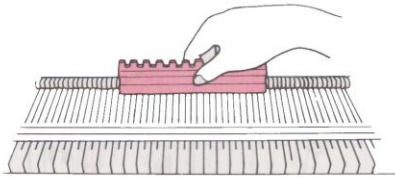

Arrange all the needles at A position.

* You can't change the Gate Pegs while the knitting is on the machine.

2

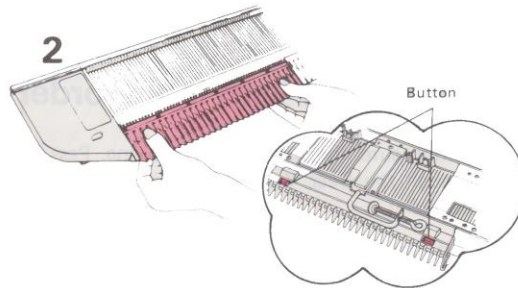

Push the buttons on the rear side of the Gate Peg and pull it to remove.

3

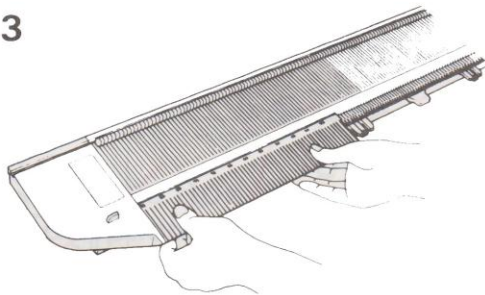

Fit in the proper Gate Pegs from the left side in order that centre needle number is 0 and the end needle number is 110 (in case of 4.5 mm pitch) or 55 (in case of 9 mm pitch).



When using 9 mm pitch Gate Pegs, you use each other needles.

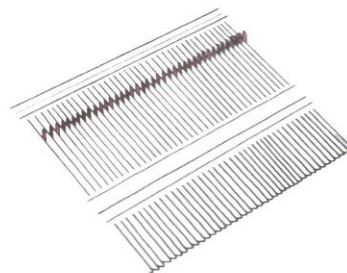

When using 4.5 mm pitch Gate Pegs, you use all the needles.

5 START TO KNIT (Tension Swatch)

We will knit the tension swatch as a practice. The tension swatch is the basis for calculating the number of stitches and rows required. The swatch is a sample piece knitted in exactly the same way as the finished garment will be knitted. This example shows the tension swatch for 1 LADY'S SWEATER (page 14) (stocking stitch).

Please prepare two yarns.

Main yarn: yarn to knit the garment

Waste yarn: different coloured yarn, you can use end of ball pieces for this, in a similar weight.

1 Thread the yarn in the order as shown

- ① Making sure the yarn is free flowing. Pass it through the Rear Yarn Guide sliding through the eyelet.
- ② Hold the yarn as shown and pull it down so that the yarn goes under the Tension Pin.
- ③ Lay the yarn over the Yarn Guide Hook and slide into Loop.
- ④ Holding the yarn in one hand, pull the Take-up Spring down and hook the yarn into the Loop.
- ⑤ Clip the yarn under the Yarn Clip until it is needed for knitting.
- ⑥ Set the arrow mark according to the thickness of yarn.
 - ▶ +380 m/100 g (Weight of yarn)
 - ▶ ◀ 220 m /100 g
 - ▶ - 160 m/100 g

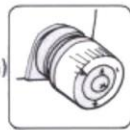

Thread the waste yarn into the left-hand Tension Unit in the same way.

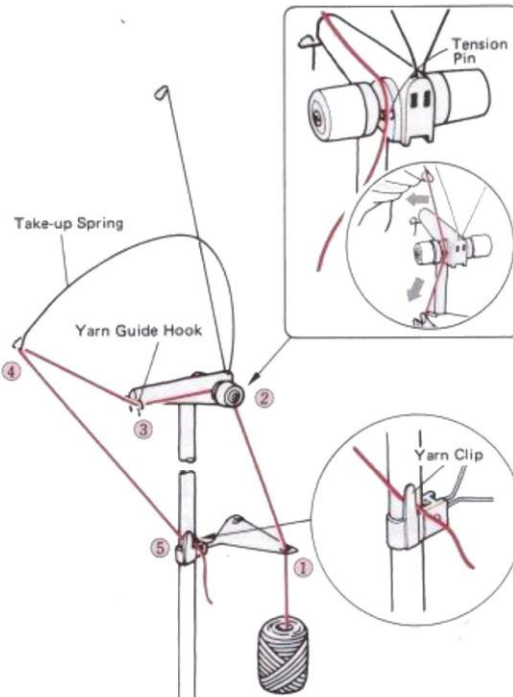

2 Arrange the needles

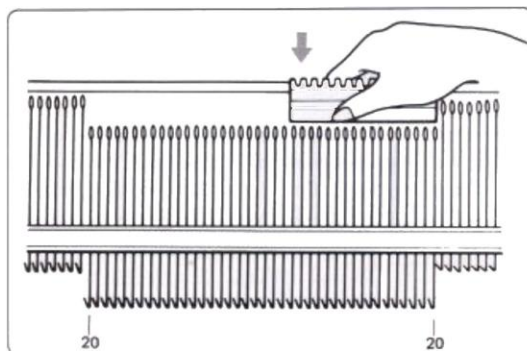

Push the required needles to B position with the flat side of the Needle Pusher, 20 needles each side of the centre – 40 needles in all – are needed for this tension swatch.

3 Pull the Carriage across the needle bed:-

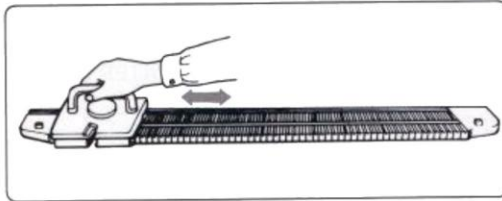

Move the Carriage across the needlebed a few times to align the needles, ending with the Carriage on the left. Make sure the Carriage clears the end needle before you move it back in the other direction.

4 Take every other needle back to A position

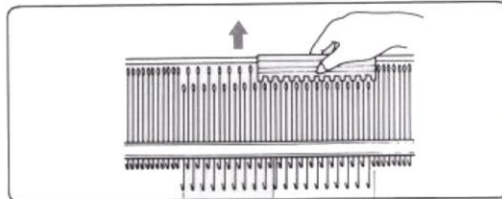

5 Set the Carriage:-

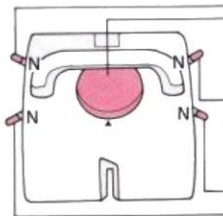

Set the Tension Dial according to the thickness of the yarn. *Refer to p. 5. *(In this example, 6)

Part Lever ... N (normal knitting), the Part Levers on each side of the Carriage towards the back.

Holding Cam Lever ... N (normal knitting), the Holding Cam Levers on each side of the Carriage towards you.

6 Set the Row Counter to 000 by turning the dials in the direction shown on the Row Counter

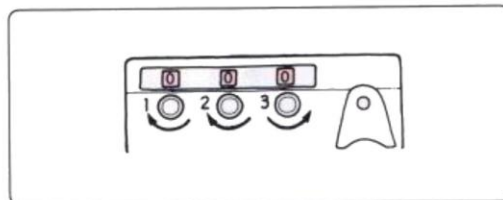

7 Thread the Yarn Feeder:-

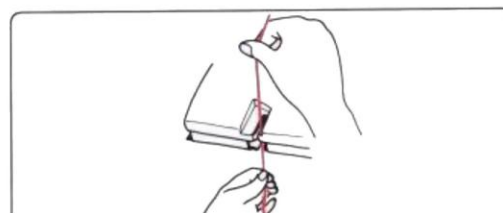

Take the main yarn out of the Yarn Clip, holding it with one hand about 30cm from the end and the other hand 10cm from the yarn end, push it to the back of the Yarn Feeder as shown.

8 Holding the yarn end gently, slowly pull the Carriage across the needles to the right.

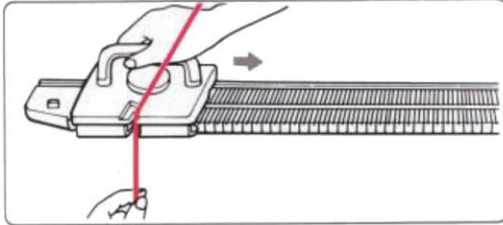

Once you feel the needles catch the yarn, you can release the end of yarn.

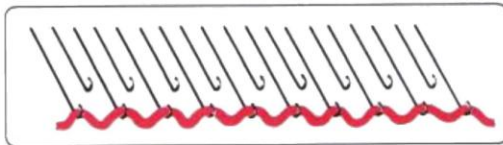

The yarn is caught on the needles in B position.

9 Hook the Cast-on Comb over the loops

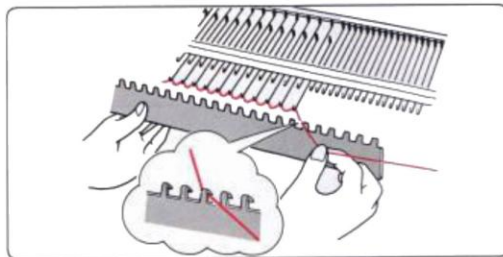

Hold the Cast-on Comb with the hooks facing the machine and hang it over the loops evenly at the same time lift the yarn between the Carriage and needlebed over the Cast-on Comb as illustrated.

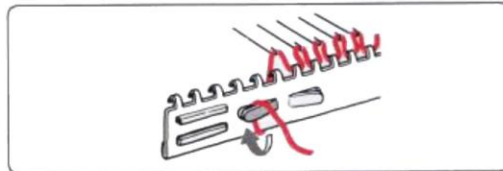

Hook the loose yarn under the Yarn Clip on the Cast-on Comb.

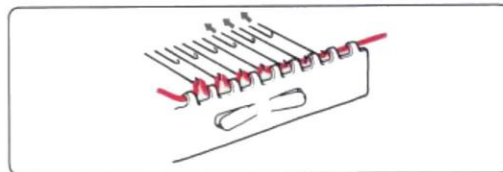

If the needles come out of B position because yarn tension is too tight, push them back to B position.

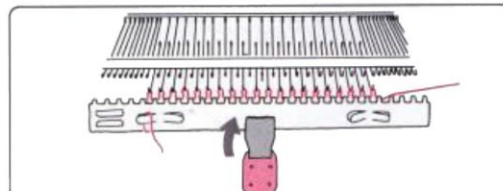

Hang the Claw Weight onto the slit of the Cast-on Comb.

10 Bring forward the empty needles to B position using the flat side of the Needle Pusher

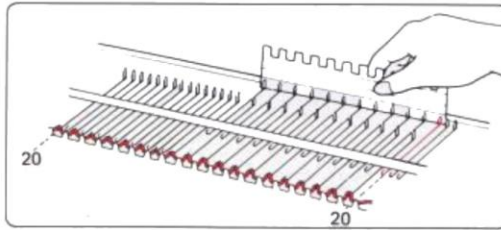

Don't forget to bring forward the end 20th needle to B position.

11 Continue knitting until the Row Counter reads 010

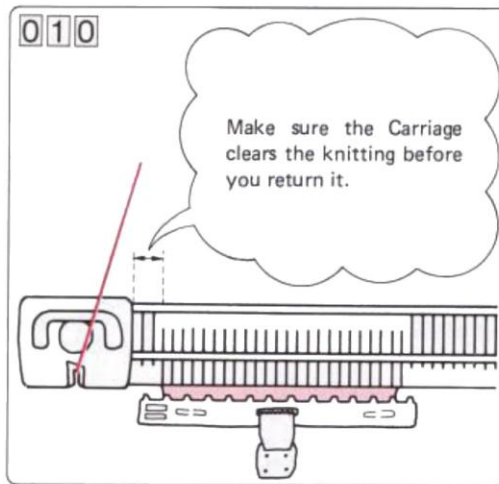

Ensure that you knit at an even speed – this gives an even tension.

12 Knit two rows in waste yarn

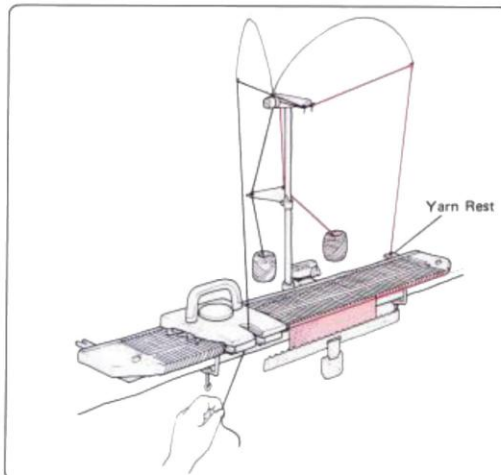

1) Take the yarn out of the Yarn Feeder and hook it onto the Yarn Rest.

*Yarn in right-hand Tension Unit is hooked onto the Yarn Rest at the right-hand side of the machine, and yarn in left-hand Tension Unit is hooked onto the Yarn Rest at the left-hand side of machine.

2) Take the waste yarn out of the Yarn Clip on the Tension Rod and thread the waste yarn into the Yarn Feeder. Knit two rows. Row Counter reads 012. Cut the waste yarn and place into the Yarn Clip on the Tension Rod.

13 Re-thread the main yarn. To avoid loops at end of work, take up any slack by pulling the main yarn back through Tension Unit. Knit 15 rows. The Row Counter reads 027.

027

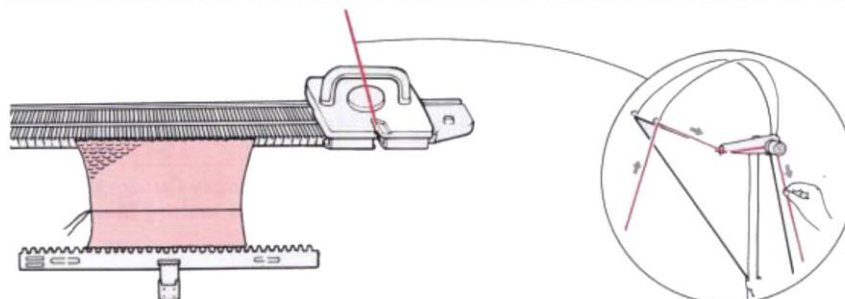

14 Cut two pieces of waste yarn (approx. 10 cm) to use as marker threads and place them onto the needles

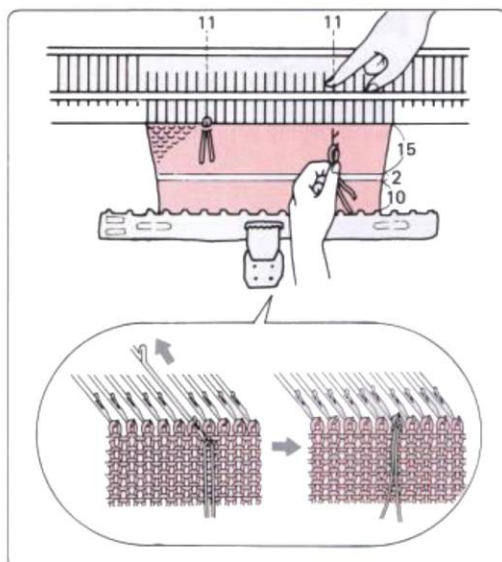

Bring forward 11th needle on each side of centre to E position. Hook a short piece of waste yarn onto the two needles and make a stitch by bringing back the needles to B position.

042

Knit 15 rows in main yarn. The Row Counter reads 042.

15 Knit two rows in waste yarn (Refer to step 12)

044

The Row Counter reads 044.

16 Re-thread the main yarn and knit 10 rows

054

The Row Counter reads 054.

17 Remove the knitting from the machine:-

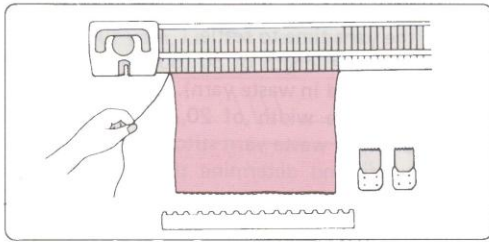

Remove the Claw Weights and the Cast-on Comb. Take the yarn out of the Yarn Feeder and cut it. Put the main yarn into the Yarn Clip on the Tension Rod.

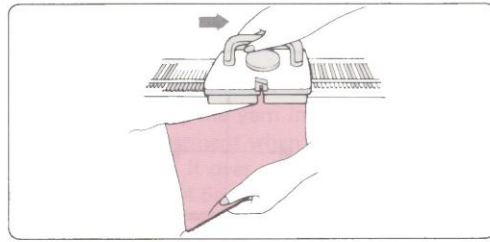

Move the empty Carriage slowly across the needles holding the knitting in one hand to release the knitting.

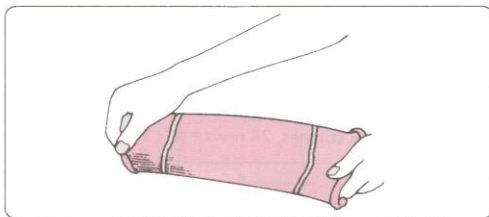

After releasing from the machine the tension swatch is often stretched sideways, pull it lengthwise 2 or 3 times to release stretch.

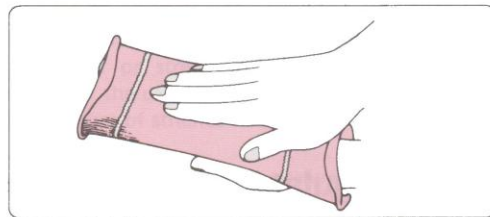

Pat the swatch lightly with your palm to make it even.

18 Press the swatch:-

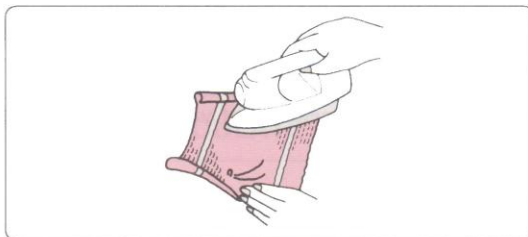

Press the swatch according to the yarn label on a blocking surface.

NOTE:

Never press the iron too hard on the swatch. If the ends are rolling inwards and you find it hard to make it settle, with the wrong side facing, use the pins to hold it in place before you press.

19 Measure the swatch:-

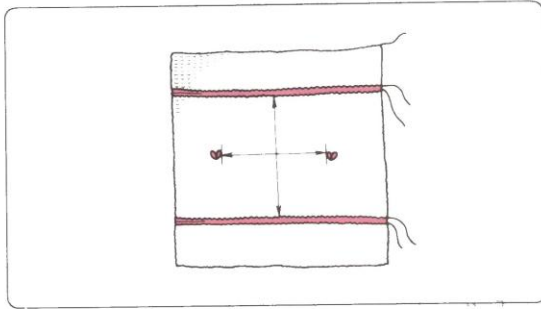

Leave the swatch on flat surface for 2 or 3 hours to give the yarn time to settle.

- 1) Measure the length of 30 (60) rows (between rows knitted in waste yarn).
- 2) Measure the width of 20 (40) stitches (between the 2 waste yarn stitches).
- 3) Calculate and determine the number of the stitches and the number of rows for 10 cm (4").

EXAMPLE: 20 stitches measures 11.1 cm
 30 rows measures 12.5 cm
 $20 \div 11.1 = 1.8$ stitches/cm.
 $30 \div 12.5 = 2.4$ rows/cm
 $1.8 \times 10 = 18$ stitches
 $2.4 \times 10 = 24$ rows
 18 stitches, 24 rows = 10 cm
 20 stitches measures 4½"
 30 rows measures 5"
 $20 \div 4½ = 4.4$ stitches/inch
 $30 \div 5 = 6$ rows/inch
 $4.4 \times 4 = 18$ stitches
 $6 \times 4 = 24$ rows
 18 stitches, 24 rows = 4"

20 Regulate the tension swatch:-

If you have the same stitches and rows as the tension given for the patterns in this book, you can follow the patterns as they appear. If you have more stitches and rows than the tension given, your work is too tight and you should try again using Tension Dial one point bigger. If you have too few stitches and rows, your work is too loose and you should try again using Tension Dial one point smaller. Tension squares show the measurement of stitches across, and length of rows. If you have to choose between the two, the width tension is the more important. The length can usually be adjusted providing the pattern stitches are not based on a given number of rows which cannot be changed (i.e. a set number of pattern repeats).

USEFUL NOTES

Ensure that you have enough yarn to complete the row and it does not run out in the middle.

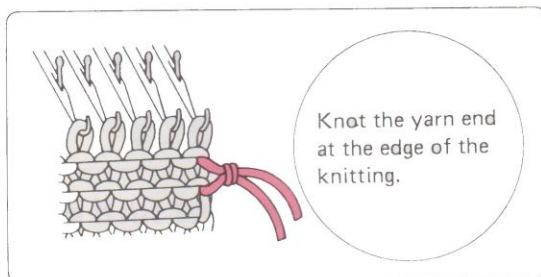

Always start a new ball of yarn at the beginning of a row.

If the Cast-on Comb is not hanging on the knitting or the knitting becomes too long, rehang the Cast-on Comb. If the edge of your knitting is tighter or doesn't knit properly, hang the Claw Weights on both edges of the actual knitting. Rehang the Weights evenly 20 rows or so.

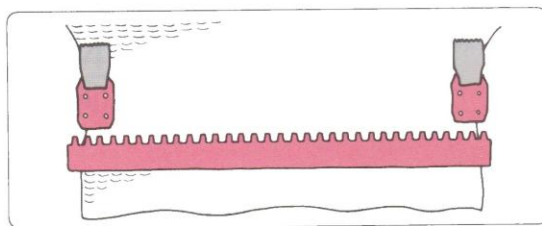

Tension Swatch 2

There is another manner to take a tension swatch. In the following manner, you need not prepare a contrast colour yarn, i.e., the waste yarn.

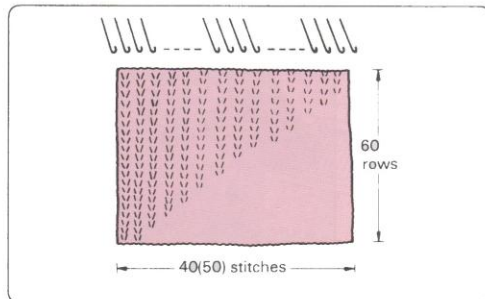

Work the swatch over not less than 40 stitches and 60 rows using the yarn in which you are going to knit the garment when you use 9mm pitch Gate Peg. (Work it over not less than 50 stitches and 60 rows with 4.5mm pitch Gate Peg.)

In the same manner as the tension swatch 1, press the swatch. Leave it dry completely before attempting to measure it.

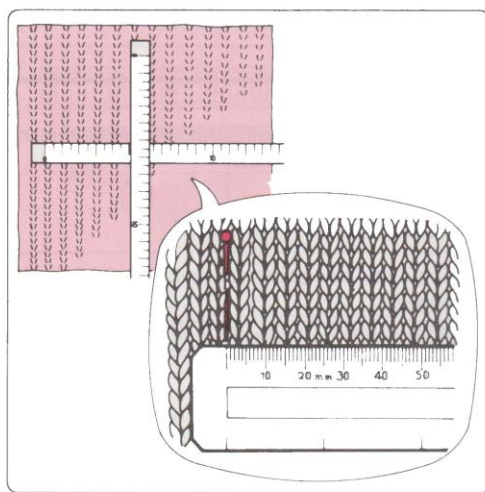

Lay the swatch on a flat surface. Taking care not to squash or stretch it, make out 10cm (4'') square in the centre using a ruler and pins. Count the number of stitches and rows for 10cm (4'').

Example:

10 cm of the horizontal line measures 18 stitches
 10cm of the vertical line measures 24 rows.
 18 stitches, 24 rows = 10cm (4'')

HOW TO CALCULATE THE NUMBER OF STITCHES AND ROWS

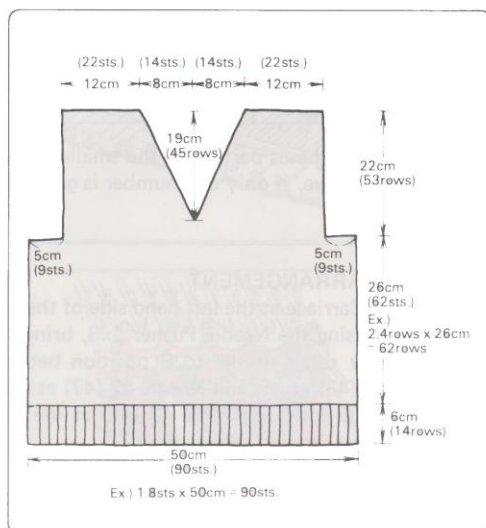

To determine the number of stitches and rows for 1cm, divide the number which you have measured in the swatch by 10cm.

Example:

$18 \text{ sts} \div 10\text{cm} = 1.8 \text{ sts.}$
 $24 \text{ rows} \div 10\text{cm} = 2.4 \text{ rows}$

HORIZONTAL AND VERTICAL LINES

No. of sts/1cm x cm of horizontal line
 = No. of sts. for width
 No. of rows/1cm x cm of vertical line
 = No. of rows for length

SLANTING LINES

To obtain the rate of increased and decrease, divide the total rows by the total stitches. But you cannot increase or decrease the stitches at the beginning or the end. Add 1 to the number of stitches.

Example: V-neck line

Decreasing 14 sts. over 45 rows
 $45 \text{ rows} \div (14 \text{ sts.} + 1) = 3 \text{ rows}$
 Decrease 1 st. every 3 rows, 14 times.

1. LADY'S SWEATER (CREW NECK)

MATERIAL : Thick yarn
 200m/100g [219y./3.52oz]
 50% acrylic, 50% wool
 ... 550g, 600g [19.4oz, 21.2oz]

TENSION (GAUGE) : stocking stitch
 9mm pitch Gate Pegs
 Tension Dial 8
 10cm [4"] = 18 sts., 24 rows

SIZE : to fit bust 86, 96cm [34, 38"]

MEASUREMENTS : finished bust 96, 106cm [38, 42"]
 length 63, 65cm [25, 26"]



THE BACK

The diagram shows 2 sizes. If only one number is shown, it pertains to both sizes. All measurements in the diagram are in centimetres and inches. The figures in brackets are in inches.

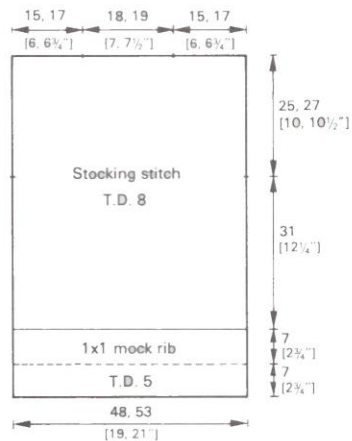

First, you are going to knit the **BACK** of the sweater.

Make sure that all levers are set to normal position.

Now you are ready to start knitting.

NOTE

For the instructions that follow, the numbers outside the parentheses pertain to the smaller size (the figures inside the parentheses reflect the larger size). As above, if only one number is given it pertains to both sizes.

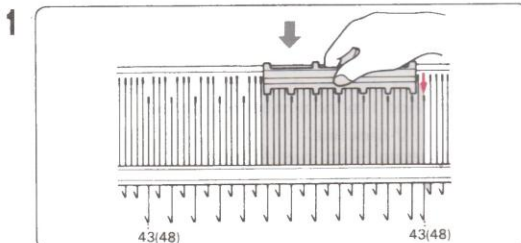

NEEDLE ARRANGEMENT

Place the Carriage at the left hand side of the needlebed. Using the Needle Pusher 1x3, bring forward every other needle to B position between Needle 43 (48) at left and Needle 42 (47) at right. Push into B position Needle 43 (48) at the right end. Set the Tension Dial to 5.

2

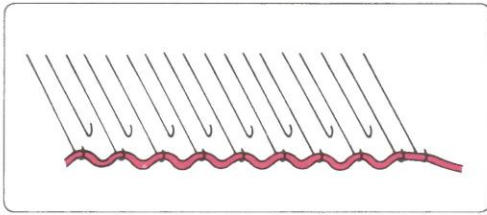

CASTING ON FOR 1x1 MOCK RIB

Before making the 1x1 mock rib, you need waste knitting. The purpose of waste knitting is to prevent the main yarn from unravelling. Knit 1 row with waste yarn.

3

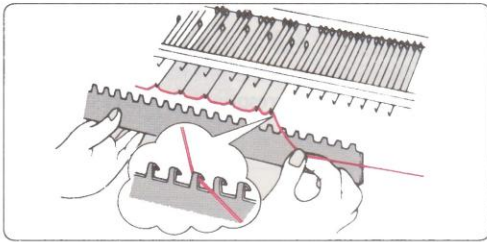

Hook the Cast-on Comb over the loops. Hang the Claw Weights onto the Cast-on Comb. Place the end of the yarn under the Yarn Clip.

4

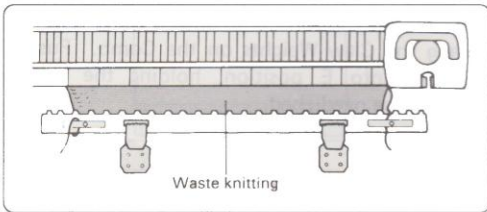

Knit a few rows, ending with the Carriage on the right. Cut the waste yarn. Set the Row Counter to 000.

5

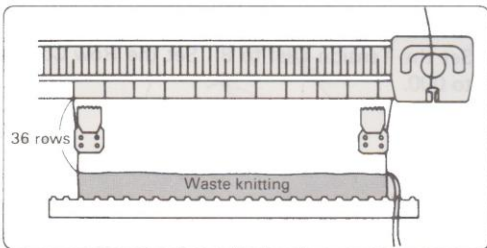

Change to the main yarn, i.e., the yarn that you will use to knit the sweater. Knit 36 rows – double the length of hem – for 1x1 mock rib.

6

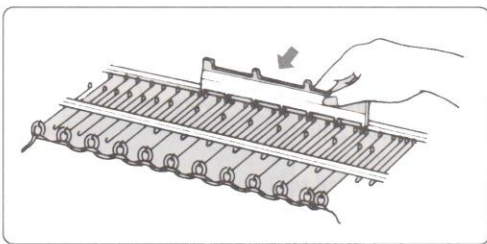

TURNING UP 1x1 MOCK RIB

Push empty needles across your work into B position using the 1x3 Needle Pusher. Remove any Weights and Comb.

7

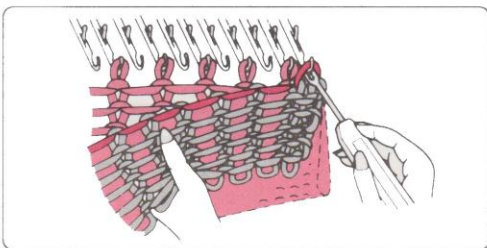

Turn up the knitting. Using the 1-eyed Transfer Tool pick up the first loop of the first row worked in the main yarn.

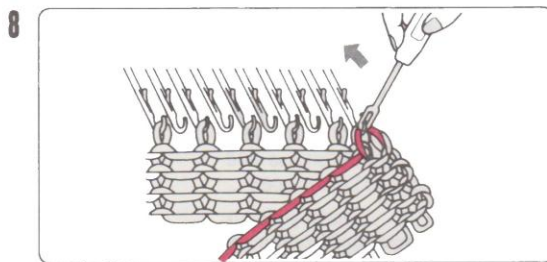

Place the Transfer Tool onto the first needle in B position. Tilt the Tool vertically upward and backward, and the loop will slide onto the needle.

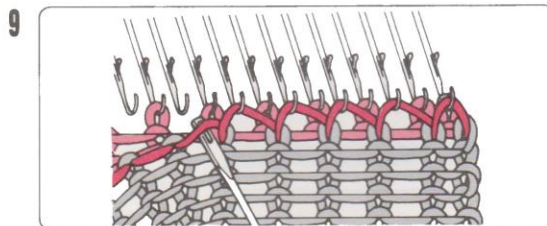

Work across the row in the same manner, pulling the knitting towards the left hand side. Place the stitches onto the corresponding empty needles.

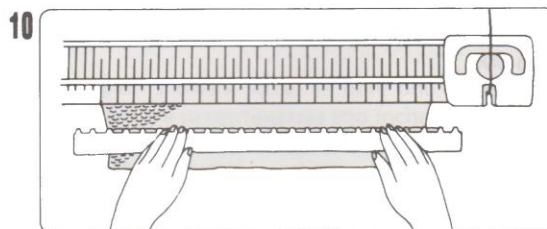

Rehang the Cast-on Comb onto the 1x1 mock rib. Hang the Claw Weights on the Comb. Push all needles into E position, holding the knitting against the needlebed.

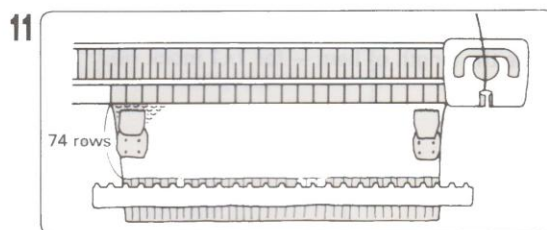

KNITTING THE BACK

Set the Tension Dial to 8. Set the Row Counter to 000.



Knit 74 rows to the underarm.

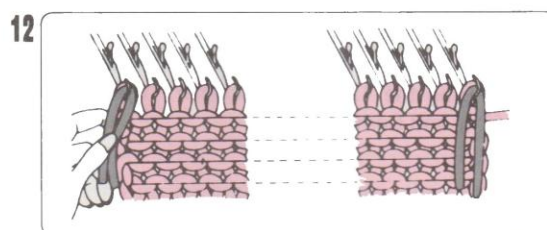

PLACING A WASTE YARN MARKER AT EACH END OF WORK

In order to find the correct placement of the sleeves, place yarn markers.

Push the end needles of your work into D position. Place 2 pieces of waste yarn onto the hook of each end needle.

Push them back to B position.

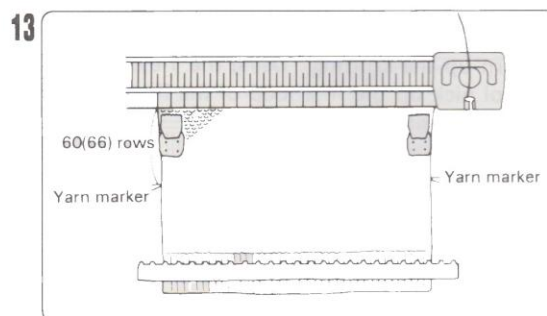

Knit 60 (66) rows to the shoulder/neck edge until the Row Counter reads 134 (140).

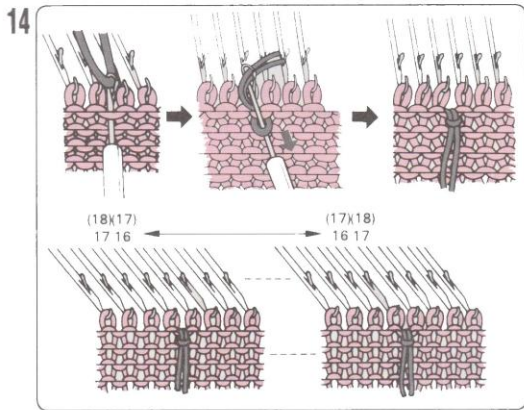

PLACING A WASTE YARN MARKER WITH THE LATCHET TOOL

Place a waste yarn marker on the loops between needle 16 (17) and 17 (18) on each side of the centre to show the neck opening. Push the Latchet Tool through the loop of the stitch and place a piece of waste yarn onto the hook of the Latchet Tool. Pull the Latchet Tool towards you so that the latchet closes, catching the waste yarn.

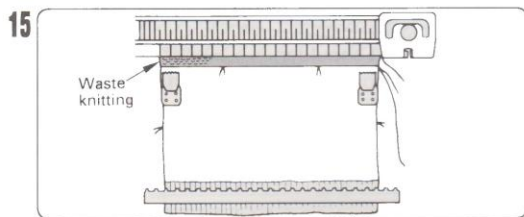

Change to the waste yarn, and knit a few rows. Break the waste yarn.

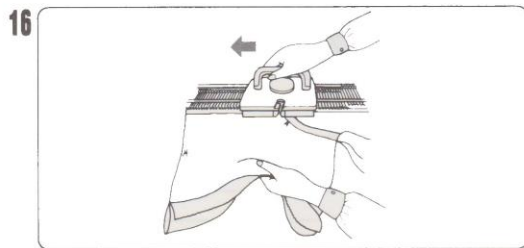

RELEASING THE BACK FROM THE MACHINE

Move the Carriage across the needlebed holding the garment in one hand and it will be released from the machine.

THE FRONT

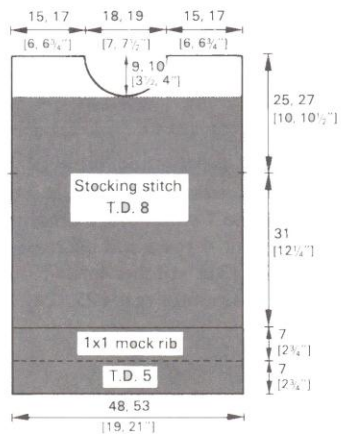

The next piece is the front of the sweater. The shaded part of the diagram is the same as the back of the sweater.

Work the FRONT as the BACK to the beginning of the front neck opening – the Row Counter reads 112 (116).

* Refer to steps 1-13.*

Now you are going to shape the neckline by decreasing stitches on 1/2 of the neckline at a time.

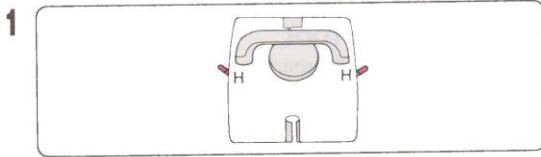

SHAPING A CREW NECKLINE

Set the Holding Cam Levers at each side of the Carriage.

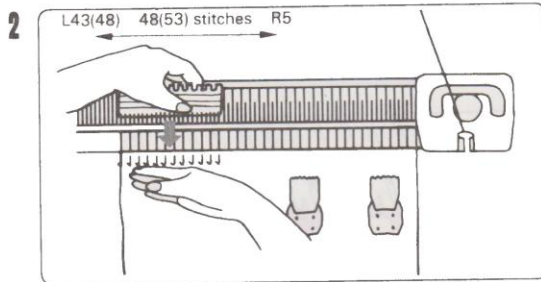

Push 48 (53) needles (left 43 (48)-right 5) on the left hand side to E position. These stitches will remain on the needles of the machine, but will not be knitted. Rehang the Claw Weights on each end of the knitting.

Set the Row Counter to 000.

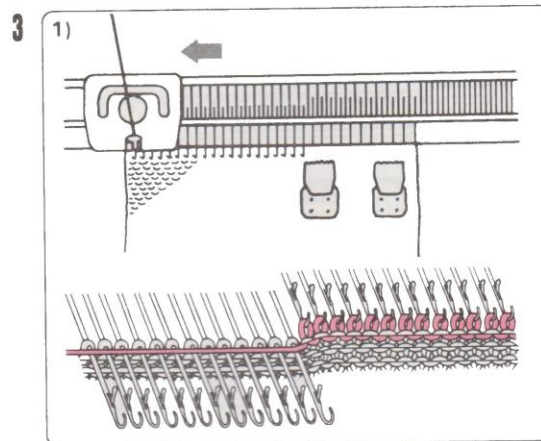
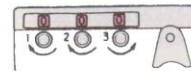

Knit the right shoulder.

1) Knit 1 row. The needles in E position are not knitted.

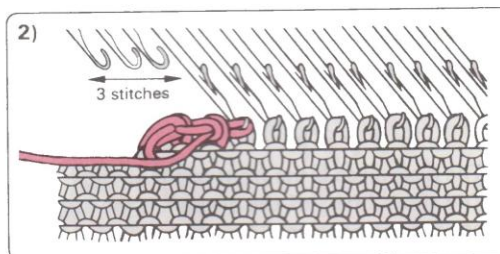

2) On the same side as the Carriage, decrease 3 stitches with the 1-eyed Transfer Tool. * Refer to Decreasing several stitches on page 58.*

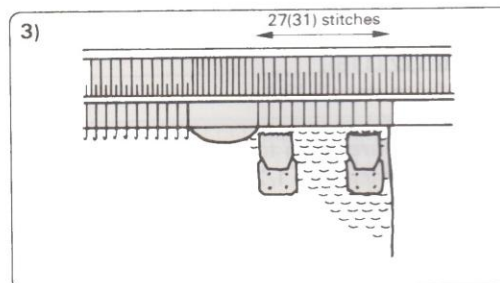

3) Knit 2 rows. At the beginning of the next and alternate rows, decrease 2 stitches 2 times. Decrease 1 stitch every other row 3 (4) times, then knit 4 rows and decrease 1 stitch. There are 27 (31) stitches left. Knit 7 rows until the Row Counter reads 22 (24).

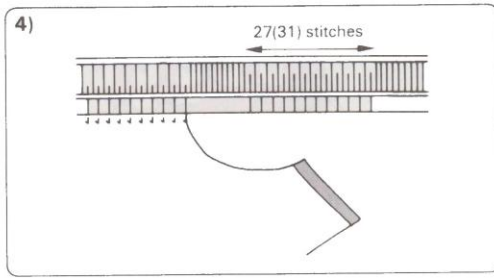

4) Change to the waste yarn, knit a few rows. Release the waste knitting from the machine.

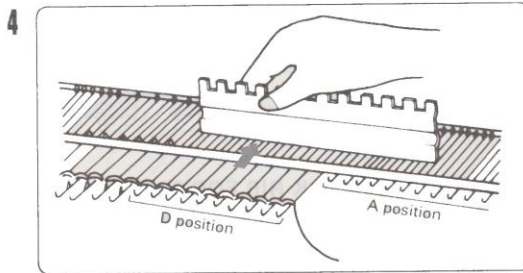

Push the empty needles into A position. Push 10 needles at the centre into D position.

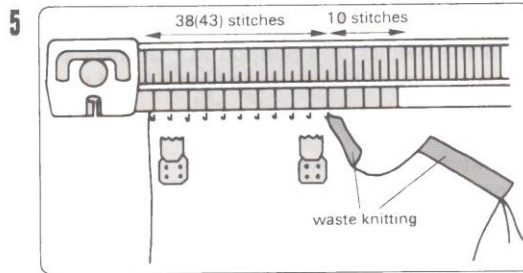

Knit a few rows in the waste yarn and release this from the machine. Remove the Comb. Place the Carriage on the left. Hang the Weights.

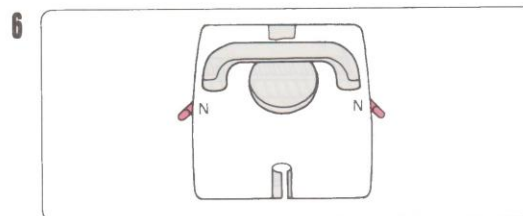

Push the empty needles into A position. Set the Holding Cam Levers to N. Set the Row Counter to 000.

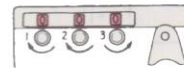

Make sure that the Carriage kicks the trigger of the Row Counter.

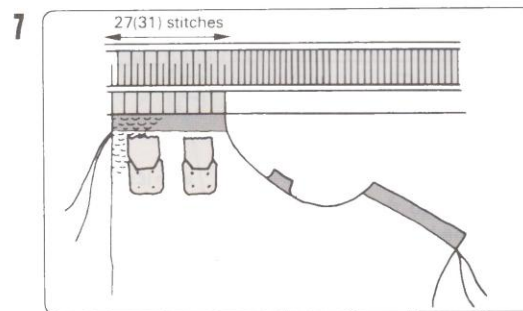

Work the left shoulder the same way as the right, reversing all shapings.

Refer to step 3. Change to the waste yarn, knit a few rows. Remove the Weights and release the knitting from the machine.

THE SLEEVES

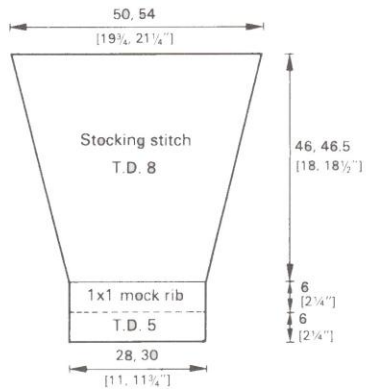

Now you are going to knit the sleeves.

Use the same technique for the mock rib on the sleeves as for the front and back of the sweater.

After finishing the mock rib, you will complete the sleeve by knitting and increasing stitches until the sleeve is the proper length and width.

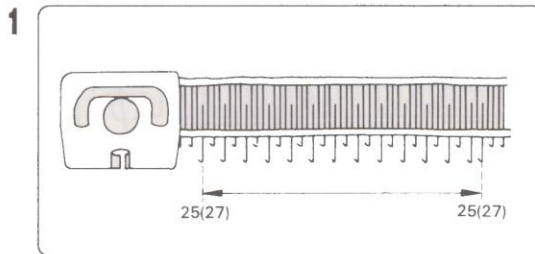

MAKING 1x1 MOCK RIB FOR SLEEVE CUFF

Place the Carriage on the left-hand side of the needlebed. Set the Tension Dial to 5. Push every other needle to B position between needle 25(27) and 24(26) with Needle Pusher. Push into B position the end needle 25(27) on the right adjacent to the needles in B position so that there are an equal number of needles on both sides of the needlebed.

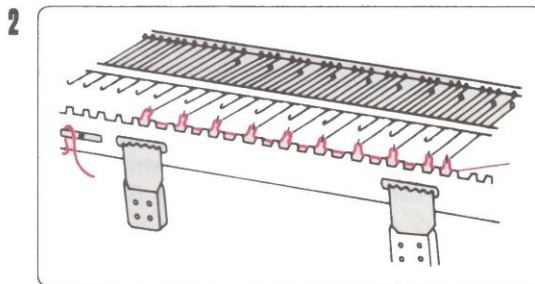

Knit 1 row with the waste yarn. Hang the Cast-on Comb and the Claw Weights. Place the end of the yarn under the Yarn Clip.

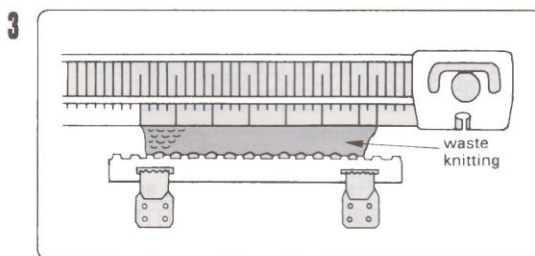

Knit a few rows ending with the Carriage on the right. Set the Row Counter to 000.

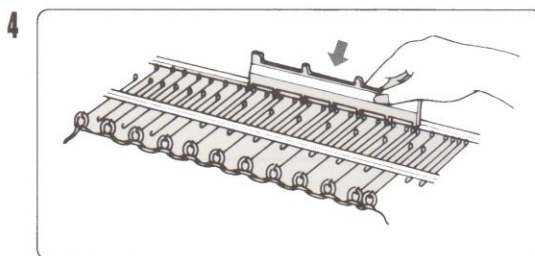
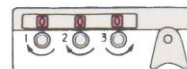

Change to the main yarn and knit 32 rows — double the length of the hem.

Push the empty needles across your work into B position using the 1x3 Needle Pusher. Remove the Weights and Comb.

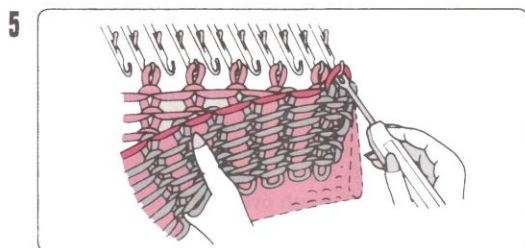

Using the Transfer Tool, pick up the first stitch of the first row worked in the main yarn and place it onto the end needle. Work across the row in the same manner, placing the stitches onto corresponding empty needles.

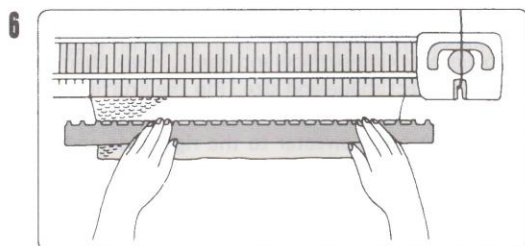

Rehang the Cast-on Comb and the Claw Weights. Holding the knitting so that it does not come towards you, push the needles into E position. Set the Tension Dial to 8. Set the Row Counter to 000.

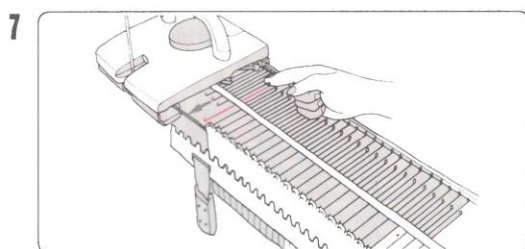
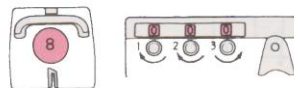

INCREASING 1 STITCH AT THE EDGE

Knit 3 rows. Bring forward to B position the empty needle adjacent to your work on the same side as the Carriage. *Refer to the simple method on page 59.*

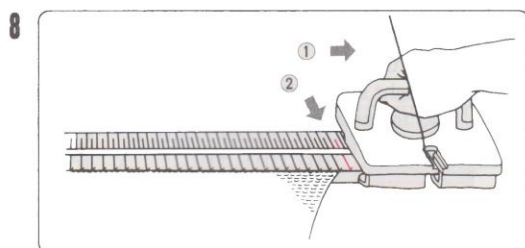

Knit 1 row. Bring forward to B position the empty needle adjacent to your work on the same side as the Carriage.

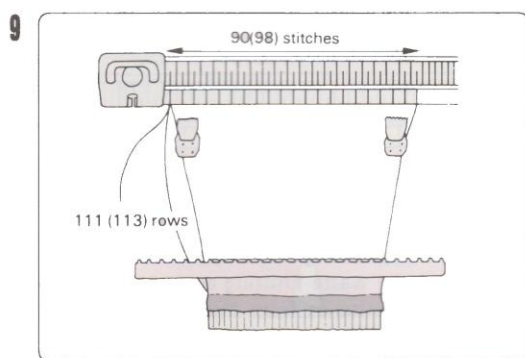

Repeat the above steps 7 and 8, which is called increasing until the Row Counter reads 28(48). Then knit 5 rows, and increase 1 stitch on the same side as the Carriage. Knit 1 row, and increase 1 stitch. Repeat this way until the Row Counter reads 106(108). There are now 90(98) stitches. Knit 5 rows more without increasing. The Row Counter reads 111(113). Break the yarn, leaving a length of approximately 3 times the knitting width for casting off. Change to the waste yarn, knit a few rows and release the knitting from the machine.

MAKE-UP

Before you work the neckband, you need to press the knitted pieces, according to the measurements given in the diagram. Before pressing them, you can remove the waste knitting you have used for casting-on. *Refer to page 62.* Use steam iron or place a damp cloth over the knitting if you use an ordinary dry iron.

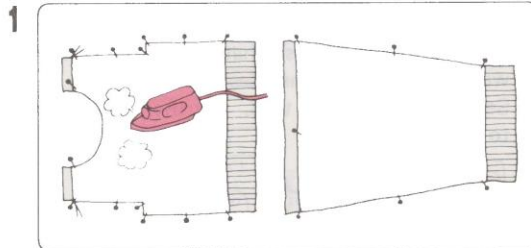

BLOCKING AND PRESSING

Lay all the pieces of your knitting, wrong side up, on a blocking surface and gently coax them into the correct shape and size. Pin the knitting to the surface and press. Do not pin or press the mock rib. Turn the sweater to the right side and press gently.

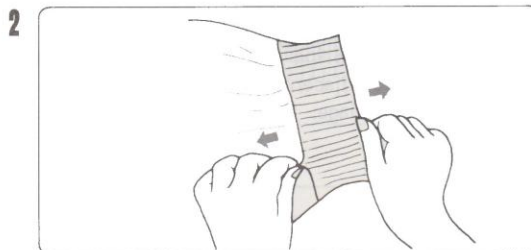

To give the mock rib a gathered appearance, gently shape the ribbing by gathering it together with your hand. Press lightly.

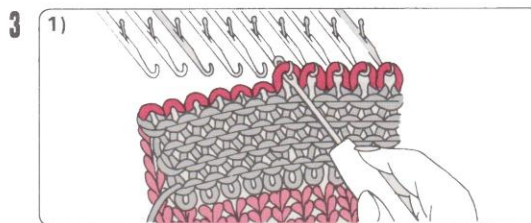

JOINING THE RIGHT SHOULDER

1) Bring forward 27(31) needles to B position. Hold the right shoulder of the FRONT with the right side facing you. Fold the waste knitting towards you and place the stitches onto the needles.

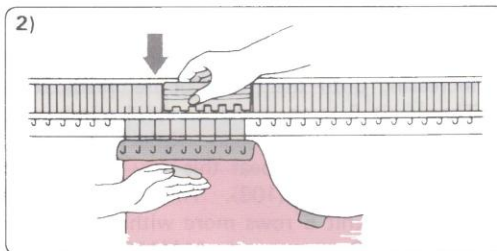

2) Push the needles into E position, holding the knitting against the needlebed.

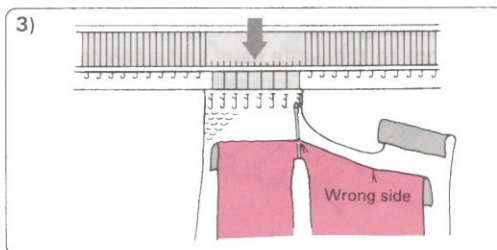

3) With the wrong side of the BACK facing you, fold the waste knitting away from you, pick up the stitches from the shoulder and place them into the hooks of the same needles.

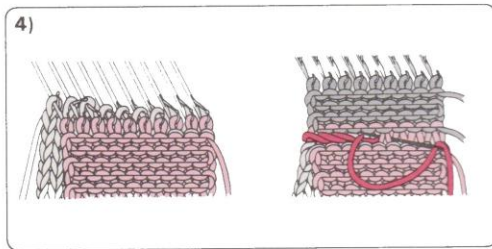

- 4) Push all the needles back to **B** position. The stitches in the needle hooks will be pulled through the stitches already on the needles to make a single stitch on each needle. Use a Tapestry Needle to bind off all stitches. *Refer to page 65.*
Remove the waste knitting from the shoulder.

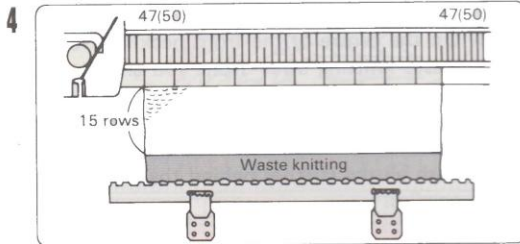

KNITTING THE NECKBAND

Knit 15 rows of the 1x1 mock rib in the same way as the **BACK**, **FRONT**, or **SLEEVES** using the needles between 47(50) and 47(50).

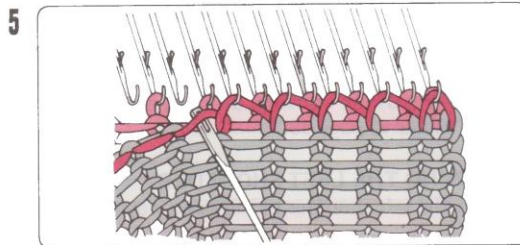

Pick up all the stitches of the first row worked in the main yarn to create a double thickness.

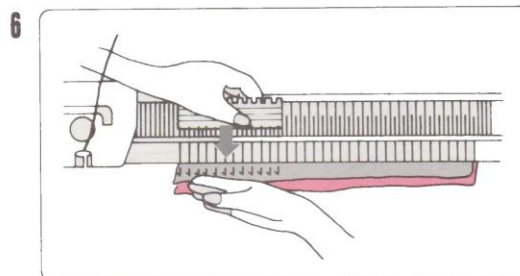

Push all the needles into **E** position, and knit 1 row with Tension Dial 4. Again push all the needles into **E** position.

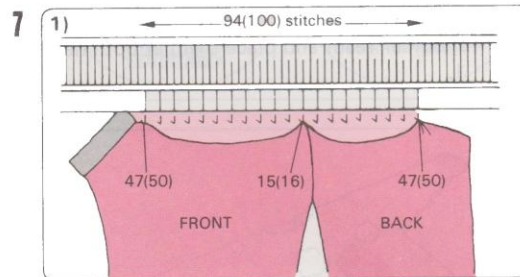

ATTACHING THE BODICE TO THE NECK-BAND

- 1) With the wrong side of the **BODICE** facing you, use the 1-eyed Transfer Tool to place the stitch in the left of the yarn marker (**BACK**) on needle Right 47(50). Place the stitch where the neck and shoulder meet (**FRONT**) on needle Right 15(16). Place the stitch in the left of **FRONT** neck on needle Left 47(50).

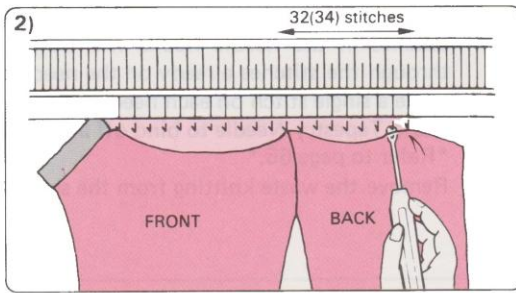

- 2) Pick up the stitches on the BACK between the shoulder seam and marker and place on corresponding needles.

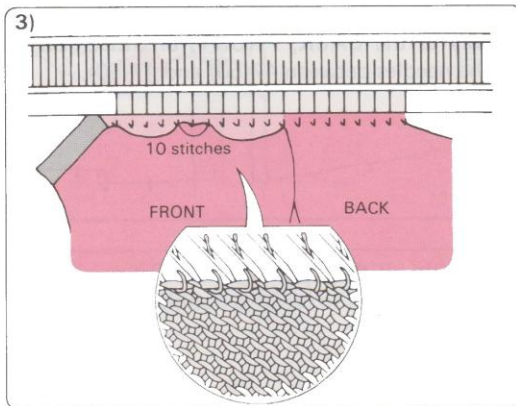

- 3) On the centre of the front neckline, fold the waste knitting away from you and place the stitches on needles 21(22) and 12(13). Place the rest of the neckline stitches evenly on the needles. Push all the stitches behind the latches of the needles.

- 4) Knit one row with Tension Dial 6, and break the yarn, leaving a length of yarn 3 times the width of the knitting. Bind off all stitches.
Refer to page 65.

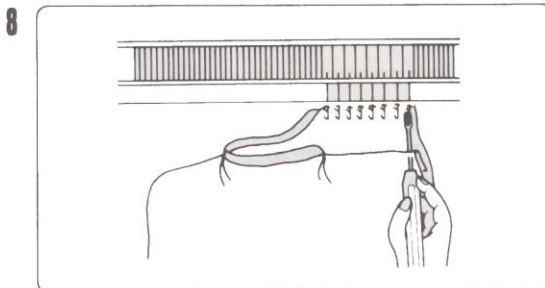

JOINING THE LEFT SHOULDER

Join the left shoulder in the same way as the right one.

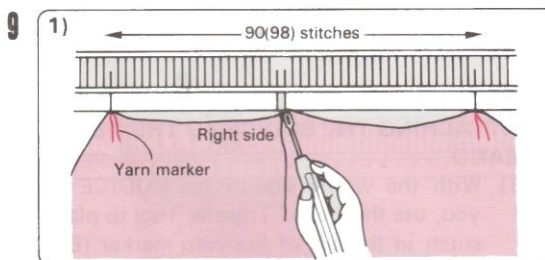

ATTACHING THE SLEEVES TO THE BODICE

- 1) Push 90(98) needles into B position. With the right side of the BODICE facing you, pick up the marked stitches and place them at both end needles 45(49). Pick up both stitches at shoulder seam and place them at both needles 1.

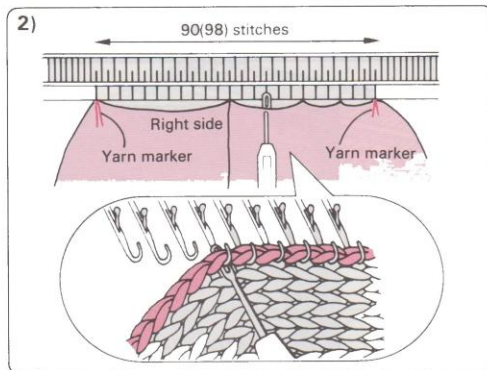

- 2) Pick up the stitches evenly along the armhole edge between the waste yarn markers and place them onto the needles.

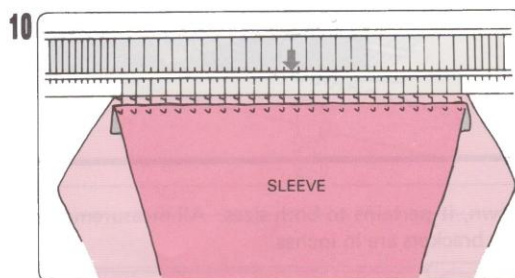

Push the needles into E position. With the wrong side of the SLEEVE facing you, place the stitches from the sleeve head onto the needle hooks. Push the needles back to B position in order to make a single stitch. Using a Tapestry Needle, bind off all stitches. *Refer to page 65.* Remove the waste knitting from the sleeve. Attach the other SLEEVE to the BODICE.

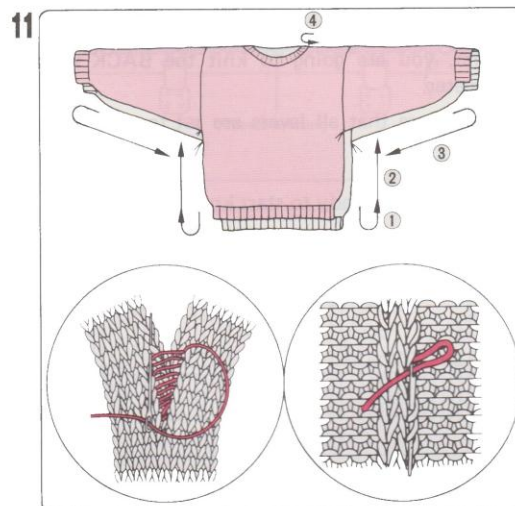

JOINING SEAMS *Refer to page 66.*

- ① Place the two seam edges side by side, wrong side up. Begin at the first row of mock rib. Using the mattress stitch, close the hem seam, first on the inside and then on the outside.
- ② Mattress stitch to the underarm.
- ③ Mattress stitch the SLEEVE seams.
- ④ Mattress stitch the NECKBAND seam, first on the outside, then on the inside.
- ⑤ Sew in the yarn ends. *Refer to page 66.*

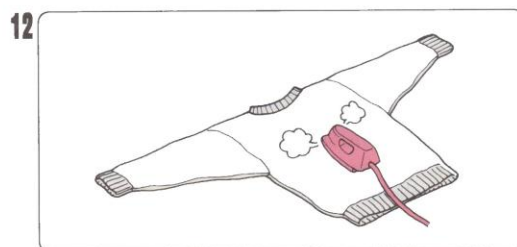

Press lightly from the wrong side. Then work over to the right side and lightly press.

2. LADY'S SWEATER (V-NECK)

MATERIAL	: Fine yarn 420m/100g [460y./3.52oz] 75% wool, 25% polyamide 400g, 500g [14oz, 17.6oz]
TENSION (GAUGE)	: stocking stitch 4.5mm pitch Gate Pegs Tension Dial 4 10cm [4"] = 28 sts., 39 rows
SIZE	: to fit bust 86, 96cm [34, 38"]
MEASUREMENTS	: finished bust 96, 106cm [38, 42"] length 63, 65cm [25, 26"]



THE BACK

The diagram shows 2 sizes. If only one number is shown, it pertains to both sizes. All measurements in the diagram are in centimetres and inches. The figures in brackets are in inches.

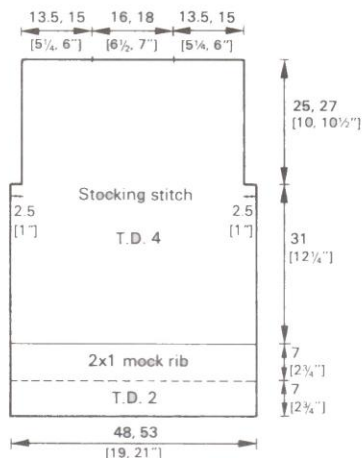

First, you are going to knit the **BACK** of the sweater.

Make sure that all levers are set to normal position.

Now you are ready to start knitting.

NOTE

For the instructions that follow, the numbers outside the parentheses pertain to the smaller size (the figures inside the parentheses reflect the larger size). As above, if only one number is given it pertains to both sizes.

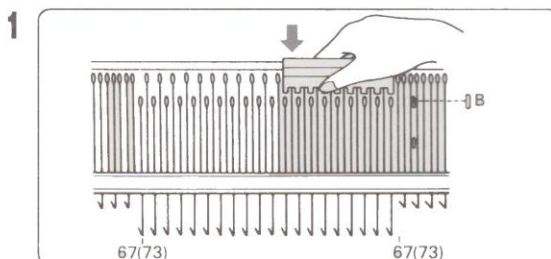

NEEDLE ARRANGEMENT

Place the Carriage on the left hand side of the needlebed. Push every other needle between Needle 67 (73) and 67 (73) using the comb side of the Needle Pusher. Set the Tension Dial to 4. Move the Carriage twice so that the needles are in a straight line across the needlebed.

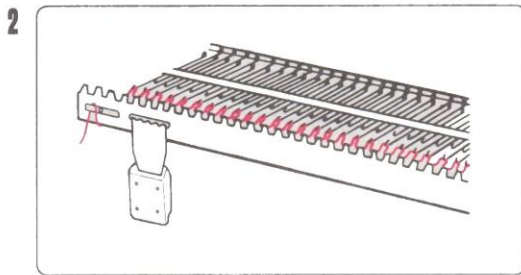

Knit 1 row with the waste yarn. Hang the Cast-on Comb and Claw Weights. Place the end of the yarn under the Yarn Clip.

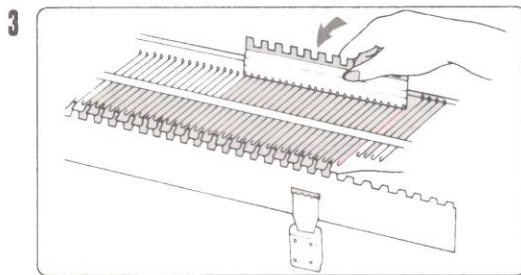

Push the empty needles across work into B position. Make sure that Needle 67(73) at the right end is in B position.

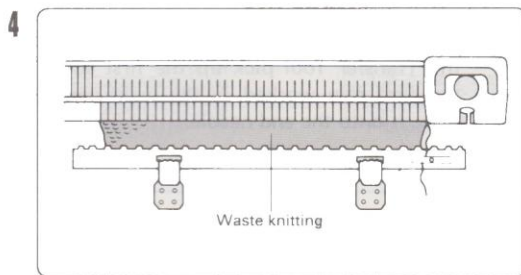

Knit 8 rows ending with Carriage at the right. Cut the waste yarn.

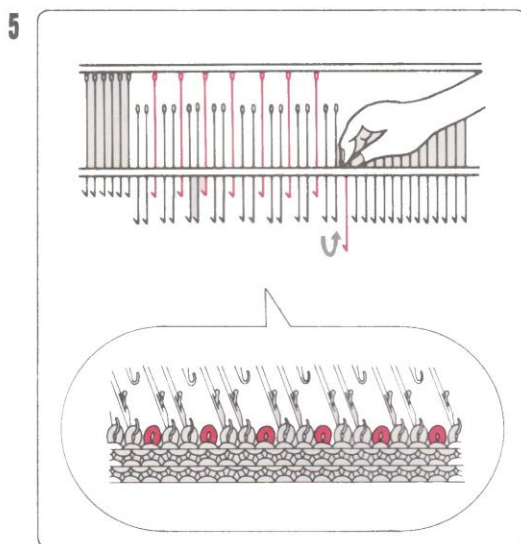

NEEDLE ARRANGEMENT FOR 2x1 MOCK RIB

Bring every 3rd needle forward to E position and then back to A position so that the stitch drops off the needle.

Work across the row in the same manner.

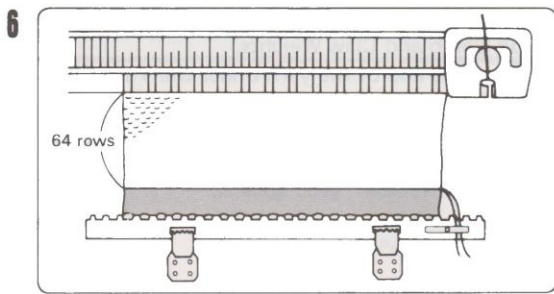

Set the Tension Dial to 2. Set the Row Counter to 000.

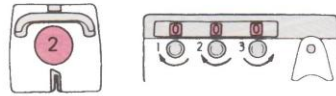

Change to the main yarn and knit 64 rows -- double the length of the hem.

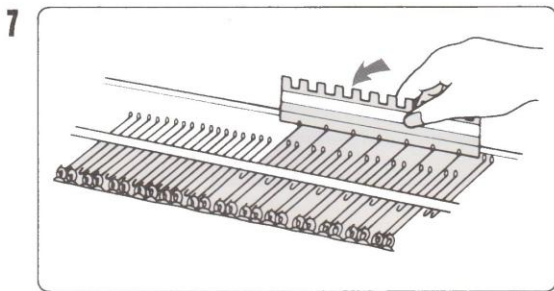

Push the empty needles across your work into B position.

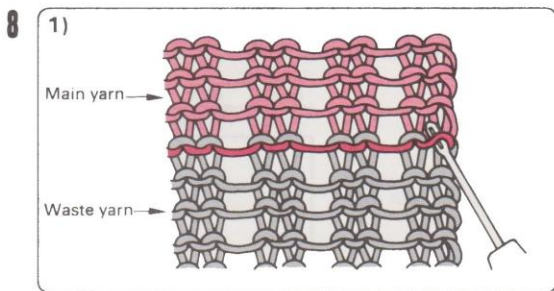

MAKING 2x1 MOCK RIB

1) Remove any Weights and the Comb. Using the Transfer Tool pick up the first stitch of the first row worked in the main yarn and place it onto the end needle.

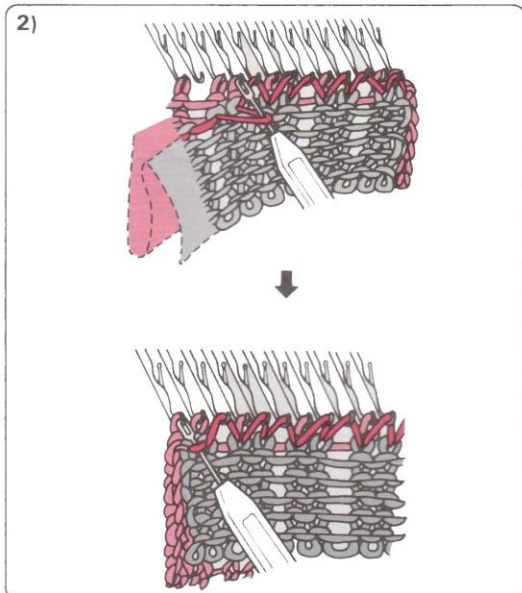

2) Work across the row in the same way, folding up the mock rib and holding it in one hand as you place the stitches on corresponding needles.

Pick up the last stitch on the left side and place it on the end needle.

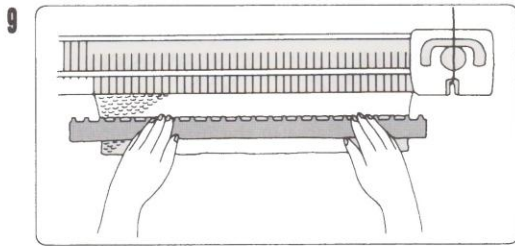

9 Rehang the Cast-on Comb and the Claw Weights. Push all needles to E position using the Needle Pusher, holding the knitting against the needlebed. Set the Tension Dial to 4. Set the Row Counter to 000.

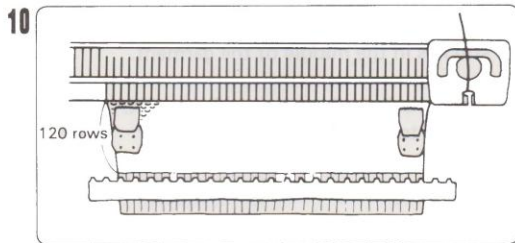
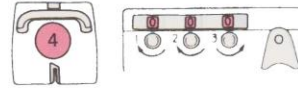

10 Knit 120 rows to the underarm.

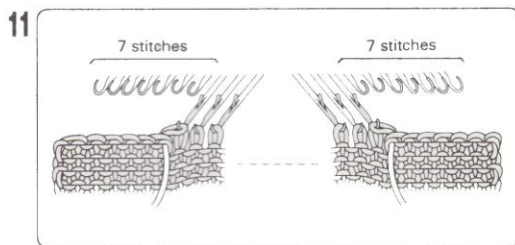

11 Cast off 7 stitches on the right, knit 1 row. Cast off 7 stitches on the left in the same manner. *Refer to Decreasing several stitches on page 58.*

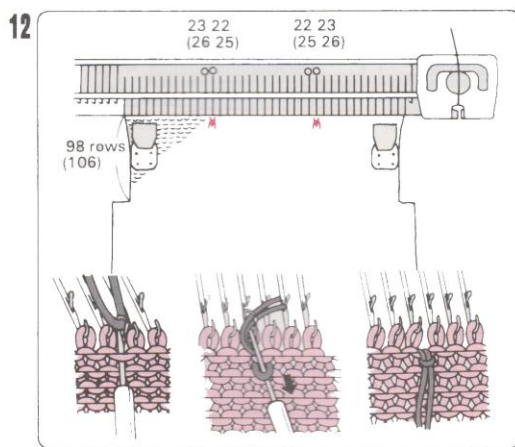

12 Knit 97(105) rows to the neck edge until the Row Counter reads 218(226). Place a waste yarn marker on the sinker loops between 22(25) and 23(26) on each side of the centre to indicate the neck opening. *Refer to page 19.*

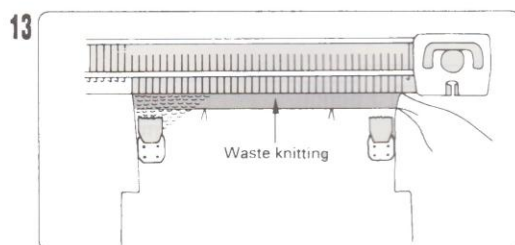

13 Change to the waste yarn and knit a few rows. Break the waste yarn and remove it from the Yarn Feeder. Remove any Weights and Comb. Move the Carriage across the needlebed, holding the knitting in one hand and it will be released from the machine.

THE FRONT

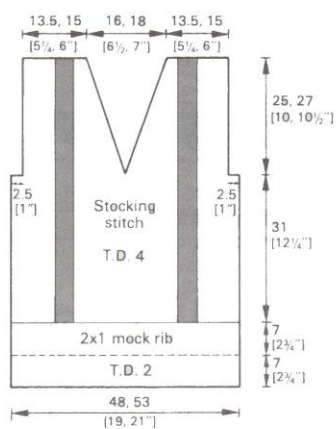

Now you are going to knit the front of the sweater. The shaded area in the diagram refers to the placement of the cable stitch. If you prefer to knit the front of the sweater without the cable stitch, simply ignore the instructions on making the cable stitch pattern.

You will create the V-neck shaping by decreasing stitches in the middle of the garment.

Work the 2x1 rib to match the BACK.
Refer to steps 1 – 9 of the BACK.

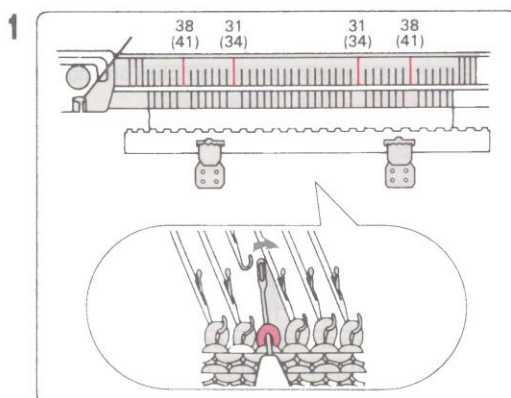

MAKING THE CABLE STITCH PATTERN

Knit 1 row, and transfer the stitches of needles 31(34) and 38(41) on both sides to the next needle using the Transfer Tool. *Refer to page 56.* Push the empty needles back to A position.

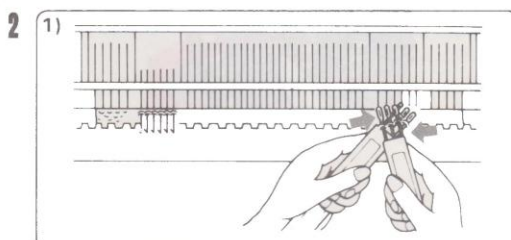

Knit 9 rows, cross the stitches using two 3-eyed Transfer Tools. *Refer to page 55.*

NOTE

On page 55, the cable stitch pattern instructs you to latch up the dropped stitches on the outside of the cable.

For the cable stitch you are making, **do not** latch up these stitches – let them remain **dropped**.

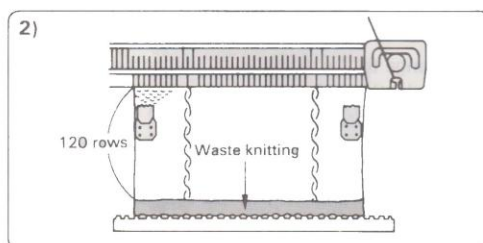

Knit 110 rows to the underarm crossing stitches every 10th row. The Row Counter reads 120.

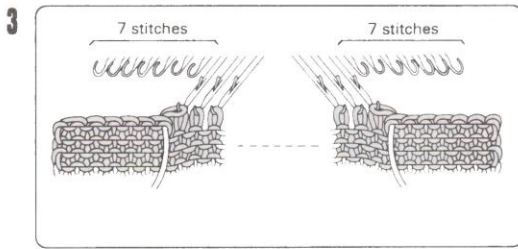

Cast off 7 stitches on the right, knit 1 row. Cast off 7 stitches on the left in the same manner.
* Refer to Decreasing several stitches on page 58.*
Knit 1 row.

SHAPING THE V-NECK OPENING

NOTE

When using the Holding Cam Levers to divide your knitting for the V-neck, the stitches in E position (Holding position) may weaken or become dirty or fuzzy. To prevent this, take these stitches off onto waste yarn instead of leaving them in E position.

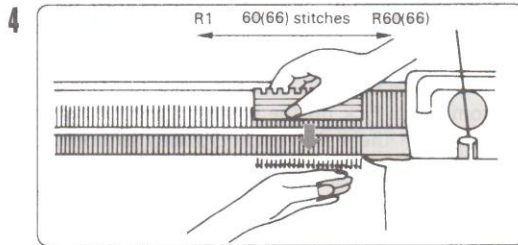

KNITTING THE RIGHT SHOULDER

Push needles between 1 and 60(66) on the right (i.e., the part you want to knit first) into E position. Set the Holding Cam Levers to H.

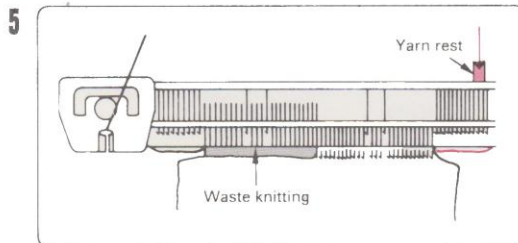
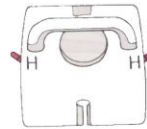

Remove the yarn from the Main Yarn Feeder and hook it onto the Yarn Rest of the needlebed. Release the Carriage, and set it on the opposite side of the needles in E position. * Refer to page 4.* Knit a few rows in the waste yarn. Remove any Weights and Comb.

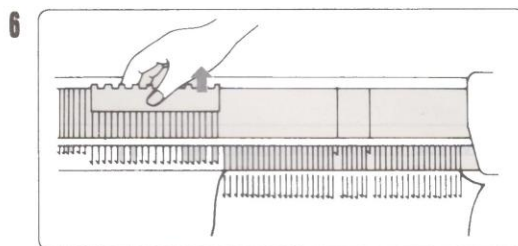

Break the waste yarn. Move the Carriage without the yarn ending with the Carriage on the right. Push the empty needles back to A position.

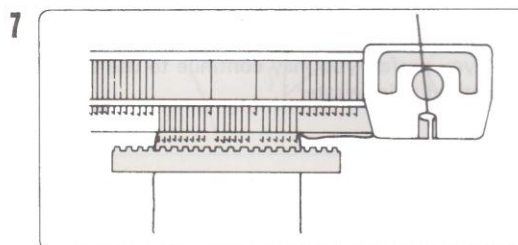

Thread the main yarn into the Main Yarn Feeder. Pull down the yarn slightly behind the Rear Yarn Guide to remove any slackness. Set the Holding Cam Levers to N. Hang on the Cast-on Comb. Set the Row Counter to 002.

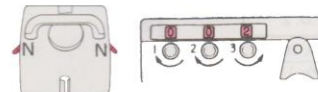

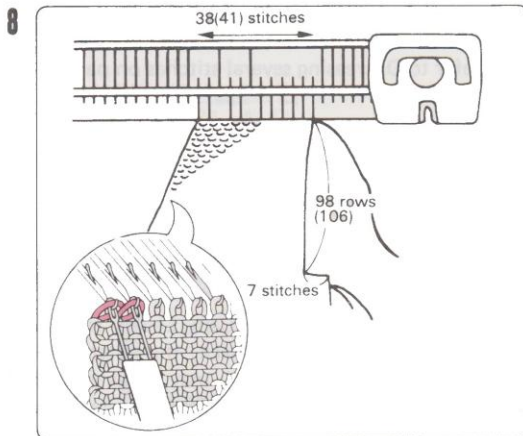

NOTE

Do not forget crossing the stitches. Knit 2 rows, and decrease 1 stitch on the left, using 2-eyed Transfer Tool. Shape the neck opening on the left edge of your work by decreasing 1 stitch every 4 rows until the Row Counter reads 76(96). Then decrease 1 stitch every 6th row 3(1) times until the Row Counter reads 94(102). 38(41) stitches remain. Knit 4 rows.

Refer to fully fashioned method on page 58.
Change to the waste yarn. Knit a few rows and release it from the machine.
Push the empty needles to A position.
Place the Carriage on the left.

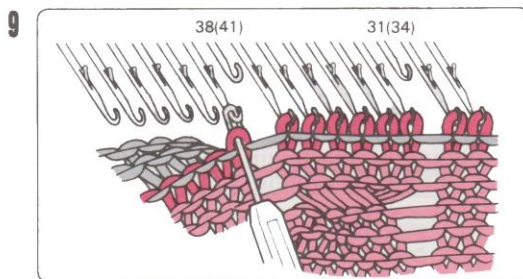

KNITTING THE LEFT SHOULDER

Push the needles between 1 and 60(66) on the left-hand side except needles 31(34) and 38(41) to B position. With the wrong side of the FRONT facing you, fold the waste knitting away from you. Pick up the stitches from the last row worked in the main yarn and place them onto the needles.

After picking up all stitches, unravel the waste knitting.

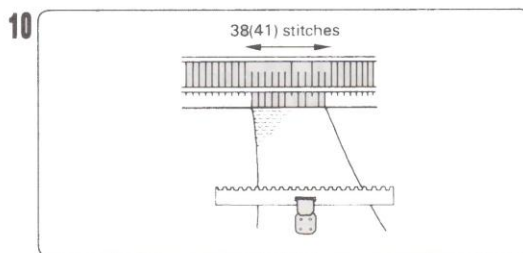

Work the LEFT SHOULDER to match the RIGHT SHOULDER reading left as right and vice versa. *Refer to steps 7 and 8.*

THE SLEEVES

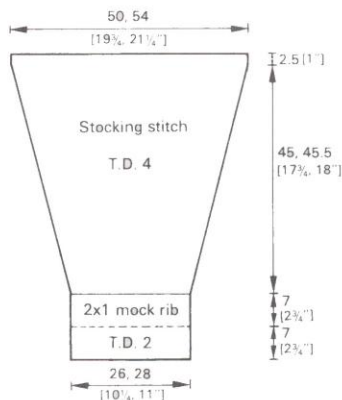

Now you are going to make the sleeves.

The cuffs are knitted in the same manner as the 2x1 mock rib on the FRONT and BACK.

You will increase the stitches using a different method from sweater 1. This method allows you to increase on both sides of the garment at the same time.

If you prefer, you may continue to use the same method as in sweater 1.

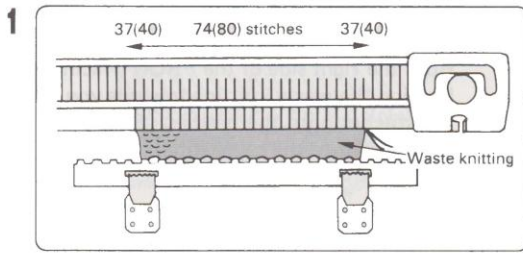

Work the cuff using 74(80) stitches to match the rib of the BACK. *Refer to steps 1 – 9 of the BACK.*

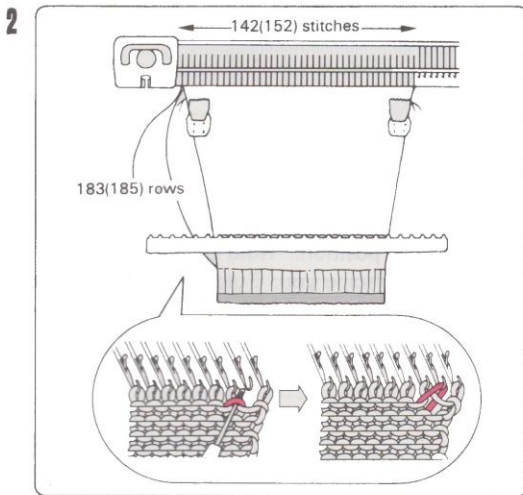

To knit the SLEEVES, knit 4 rows. Increase 1 stitch at each end AT THE SAME TIME. *Refer to fully fashioned method on page 59.* Next, increase 1 stitch every 4th row 15(20) times until the Row Counter reads 64(84), then every 6th row 18(15) times. The Row Counter reads 172(174). Put a yarn marker on each side of the edge. *Refer to page 18.* Knit 11 rows. 142(152) stitches remain. Break the main yarn leaving a length of approximately 3 times the width of the knitting. Change to the waste yarn, knit a few rows and release it from the machine.

MAKE-UP

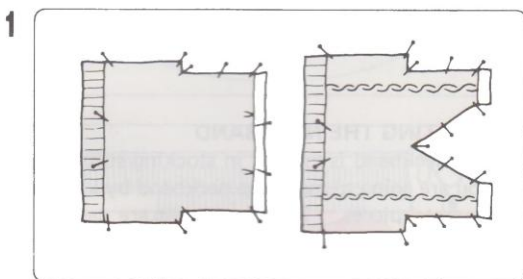

BLOCKING AND PRESSING

Remove the waste knitting you have used for casting on. *Refer to page 62.*

Lay all the pieces of your knitting, wrong side up on a blocking surface and gently coax them into the correct shape and size. Pin the knitting to the surface and press. Do not pin or press the mock rib. Turn the sweater to the right side and press gently.

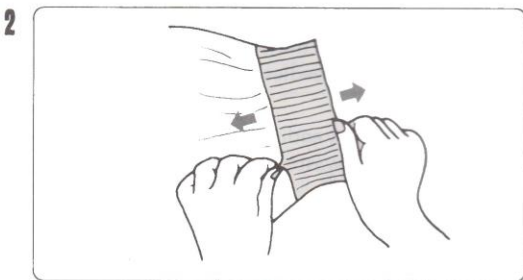

To give the mock rib a gathered appearance, gently shape the ribbing by gathering it together with your hand. Press lightly.

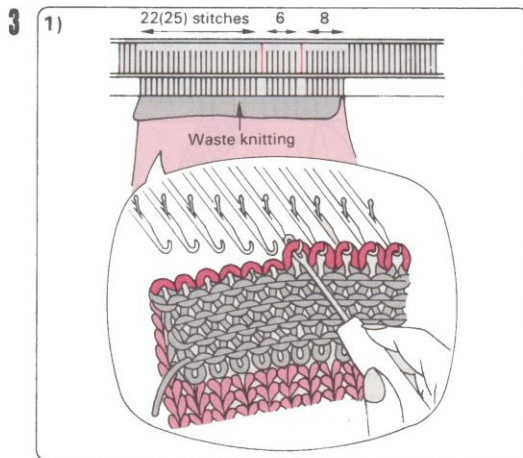

JOINING THE RIGHT SHOULDER

1) Push 38(41) needles into B position. Hold the right side of the FRONT facing you. Folding the waste knitting towards you, place the stitches onto the needles. Skip each needle adjacent to the cable stitch.

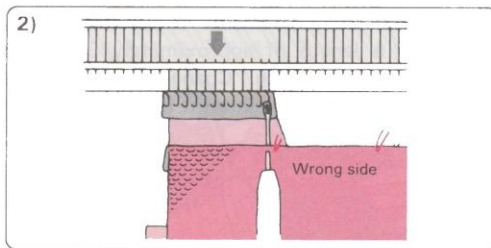

2) Push the needles including 2 empty needles into E position. Hold the wrong side of the BACK facing you. Folding the waste knitting away from you, and place the stitches onto the hooks of the needles.

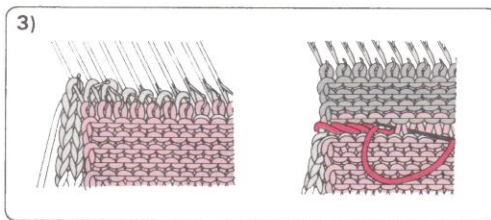

3) Push the needles back to B position in order to make a single stitch. Using a Tapestry Needle, bind off the row knitted in the main yarn. * Refer to page 65.* Remove the waste knitting.

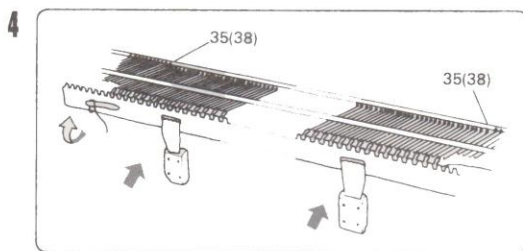

KNITTING THE NECKBAND

The neckband is knitted in stocking stitch. Now you are going to make the neckband by knitting 2 separate pieces. 70(76) stitches are cast on to make the 1st piece and 114(126) stitches for the 2nd piece. You are going to make the short piece first. Set the Tension Dial to 3. Cast-on every other needle between 35(38) and 35(38) with the waste yarn. Hang the Cast-on Comb and Weights. Push the empty needles into B position.

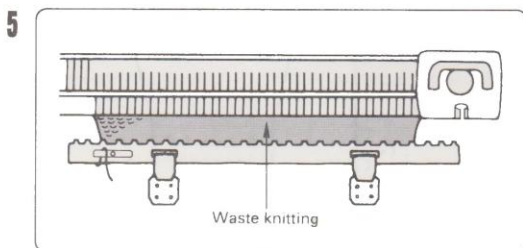

Knit a few rows ending with the Carriage on the right. Cut the waste yarn. Set the Row Counter to 000.

Set the Holding Cam Levers to H.



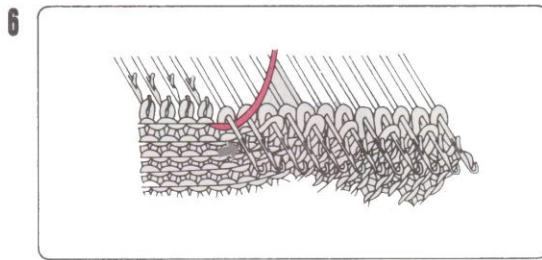

Knit 1 row with the main yarn. On the right side which will be at the centre front, push 2 needles into E position. Knit 1 row, and pass the yarn under the needle. Continue in this manner until the Row Counter reads 012.

Refer to steps 1 – 3 on page 60.

Change the Tension Dial to 6, and knit 1 row to make a folding line.

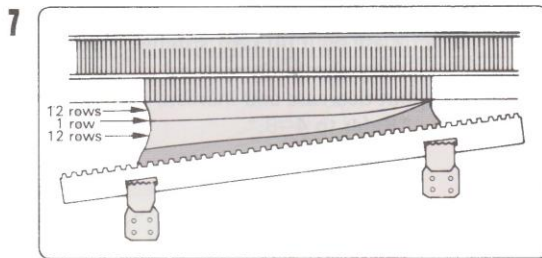

Return the Tension Dial to 3. Push 2 needles which are nearest to the knitting in B position back into D position. Knit 1 row, and pass the yarn under the needle. Knit 1 row. Continue in this manner until the Row Counter reads 025.

Refer to page 61. Remove any Weights and Comb.

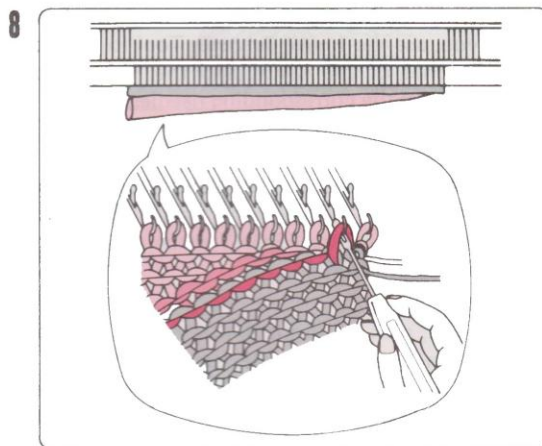

Pick up all the stitches of the first row worked in the main yarn and hook them onto the corresponding needles. Push all needles into E position holding the knitting against the needlebed. Set the Holding Cam Levers to N. Knit 1 row with Tension Dial 1.

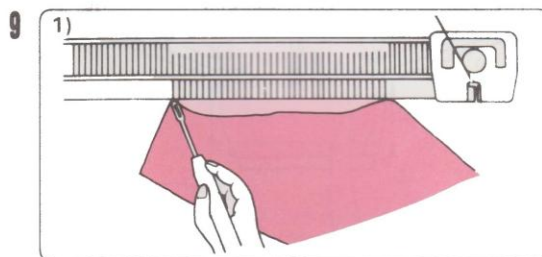

1) With the wrong side of the BODICE facing you, use the 1-eyed Transfer Tool to place the stitches on the LEFT neck edge.

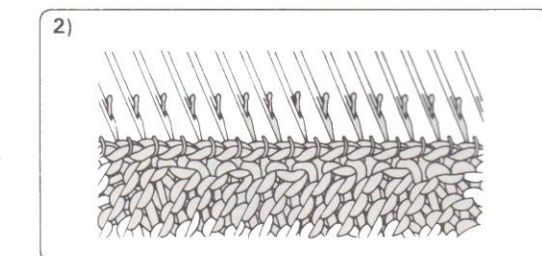

2) Pick up the stitches on the LEFT neck edge, and hook them evenly onto the needles.

6

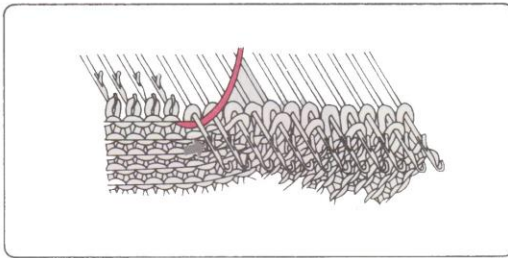

Knit 1 row with the main yarn. On the right side which will be at the centre front, push 2 needles into E position. Knit 1 row, and pass the yarn under the needle. Continue in this manner until the Row Counter reads 012.

Refer to steps 1 – 3 on page 60.

Change the Tension Dial to 6, and knit 1 row to make a folding line.

7

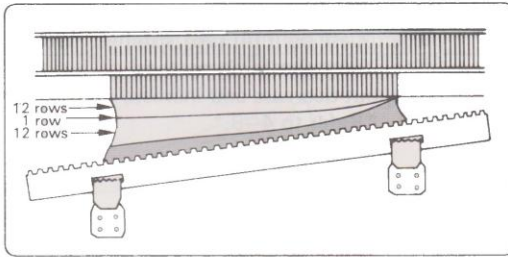

Return the Tension Dial to 3. Push 2 needles which are nearest to the knitting in B position back into D position. Knit 1 row, and pass the yarn under the needle. Knit 1 row. Continue in this manner until the Row Counter reads 025.

Refer to page 61. Remove any Weights and Comb.

8

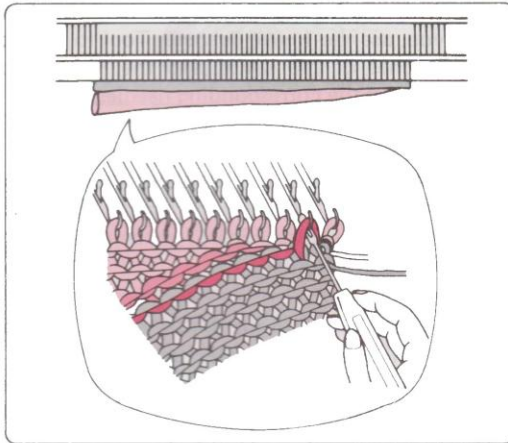

Pick up all the stitches of the first row worked in the main yarn and hook them onto the corresponding needles. Push all needles into E position holding the knitting against the needlebed. Set the Holding Cam Levers to N. Knit 1 row with Tension Dial 1.

9

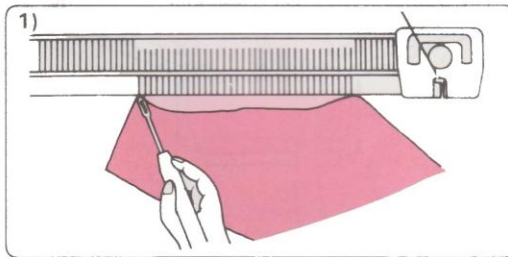

1) With the wrong side of the BODICE facing you, use the 1-eyed Transfer Tool to place the stitches on the LEFT neck edge.

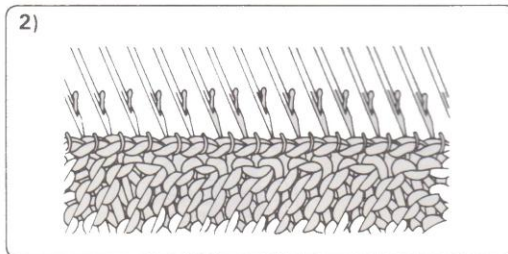

2) Pick up the stitches on the LEFT neck edge, and hook them evenly onto the needles.

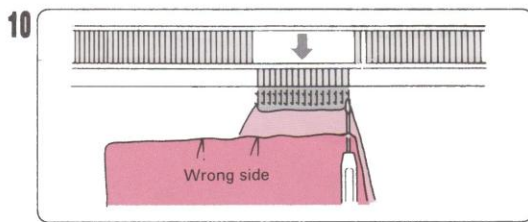

JOINING THE LEFT SHOULDER

Join the left shoulder in the same way as the right shoulder.

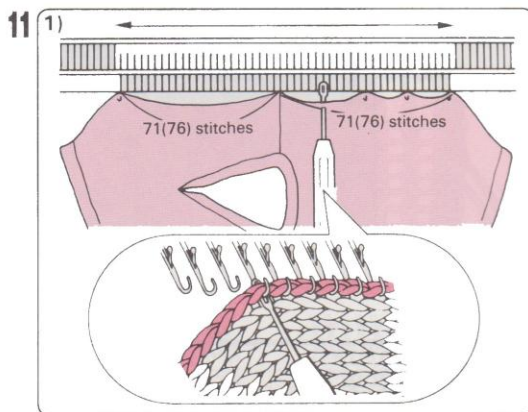

ATTACHING THE SLEEVE TO THE BODICE

1) Push 142(152) needles into B position. With the right side of the BODICE facing you, pick up the same number of stitches evenly along the armhole edge and place them onto the needles.

Holding the knitting so that it does not come towards you, push the needles into E position. With the wrong side of the sleeve facing you, pick up the stitches from the last row knitted in the main yarn and place them onto the hooks of the needles.

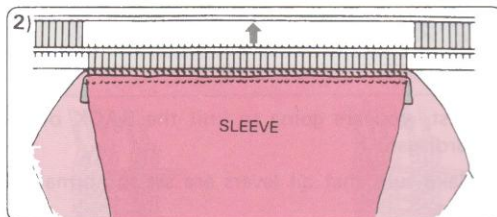

2) Push the needles back to B position in order to make a single stitch.

Using a Tapestry Needle, bind off the row knitted in the main yarn. *Refer to page 65.* Remove the waste knitting from the sleeve.

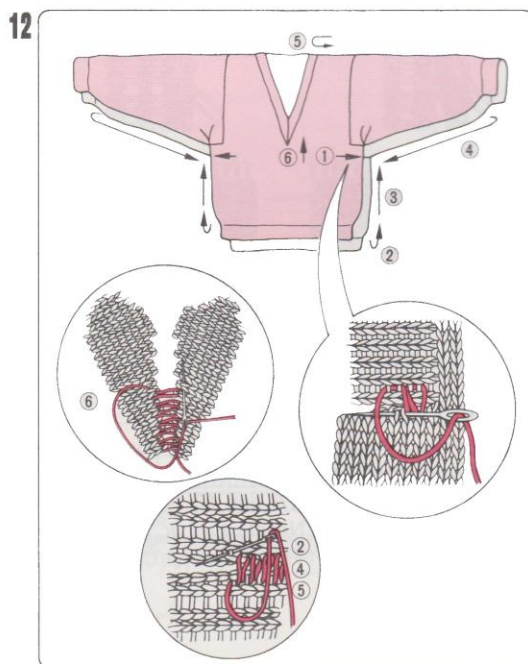

JOINING SEAMS *Refer to page 66.*

- ① Place 2 seam edges side by side, right side up. First, join the underarm sleeve to the bodice using the mattress stitch. The yarn marker on the sleeve shoulder match the underarm seam.
- ② Turn the wrong side up. Begin at the first row of the hem. Using the mattress stitch close the rib seam, first on the inside and then the outside.
- ③ Mattress stitch to the underarm.
- ④ Mattress stitch the SLEEVE seams.
- ⑤ Mattress stitch the COLLAR seams, first on the outside and then on the inside.
- ⑥ Mattress stitch the centre FRONT, right side up.
- ⑦ Sew in the yarn end and give it a final press.

3. LADY'S CARDIGAN (V-NECK)

MATERIAL : Chunky yarn
 170m/100g [190y./3.52oz]
 100% wool
 600g, 700g [21.2oz, 24.7oz]
 2cm buttons (5 pieces)

TENSION (GAUGE) : stocking stitch
 9mm pitch Gate Pegs
 Tension Dial 9
 10cm [4"] = 17 sts., 23 rows

SIZE : to fit bust 86, 96cm [34, 38"]

MEASUREMENTS : finished bust 99, 109cm [39, 43"]
 length 65, 67cm [25.5, 26.5"]

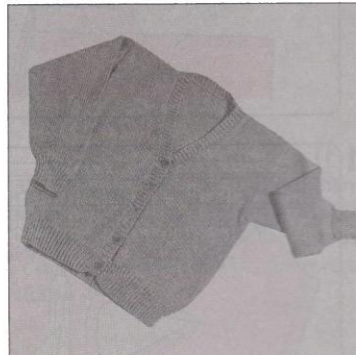

THE BACK

The diagram shows 2 sizes. If only one number is shown, it pertains to both sizes. All measurements in the diagram are in centimetres and inches. The figures in brackets are in inches.

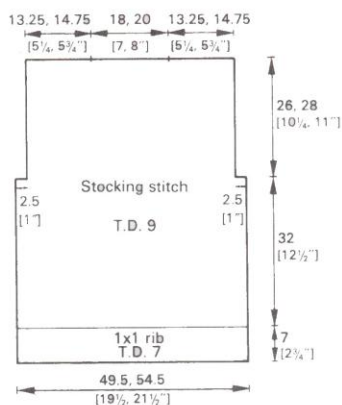

First, you are going to knit the **BACK** of your cardigan.

Make sure that all levers are **set to normal** position.

Now you are ready to start knitting.

NOTE

For the instructions that follow, the numbers outside the parentheses **pertain to the smaller size** (the figures inside the parentheses reflect the larger size). As above, if **only one number** is given it pertains to both sizes.

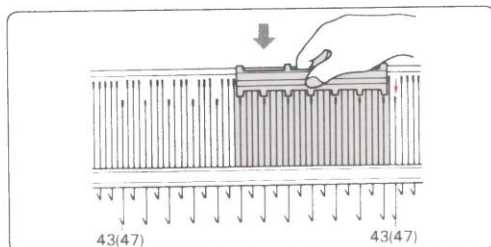

NEEDLE ARRANGEMENT

Place the Carriage at the left-hand side of the needlebed. Set the Tension Dial to 5. Push every other needle between 43 (47) and 43 (47) into B position using the 1x3 Needle Pusher. Push into B position Needle 43 (47) on the right.

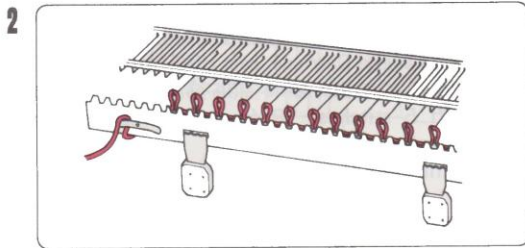

CASTING ON FOR 1x1 RIB

Knit 1 row with the waste yarn. Hang the Comb and the Weights. Place the end of the yarn under the Yarn Clip.

Knit a few rows ending with the Carriage on the right. Set the Row Counter to 000.

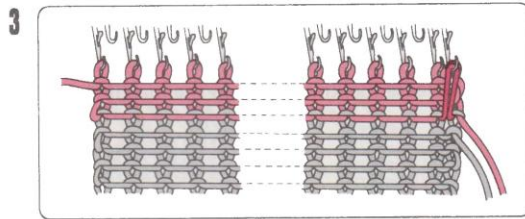
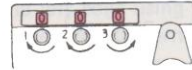

Change to the main yarn and knit 3 rows – for a finished edge. Pick up the right end loop of the first row and hang it onto the end needle using the Transfer Tool.

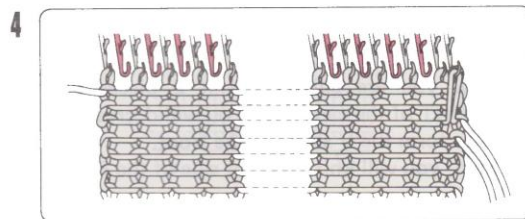

Push the empty needles across your work into B position using the 1x3 Needle Pusher. Set the Tension Dial to 7.

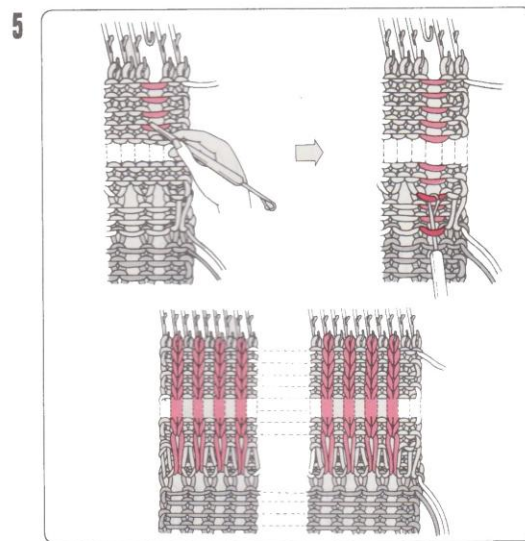

MAKING 1x1 RIB WITH THE LATCHET TOOL

Knit 19 rows until the Row Counter reads 022. Remove the Weights and Comb. Drop the 3rd stitch from the right end and unravel the stitches by using the tip of the Latchet Tool.

Insert the Latchet Tool under the sinker loop of the 1st row and catch the 3rd parallel thread (miss 2 rows) with the hook of the Latchet Tool, then pull the Latchet Tool towards you to make a plain stitch. Continue this way to the top, and hook it onto the needle. *Refer to page 57.*

Make purl stitches from the first row knitted in the main yarn every other needle.

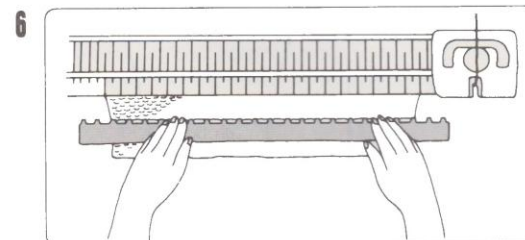

Rehang the Cast-on Comb and the Weights. Set the Tension Dial to 9 and set the Row Counter to 000.

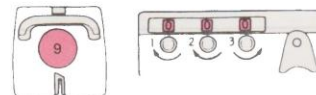

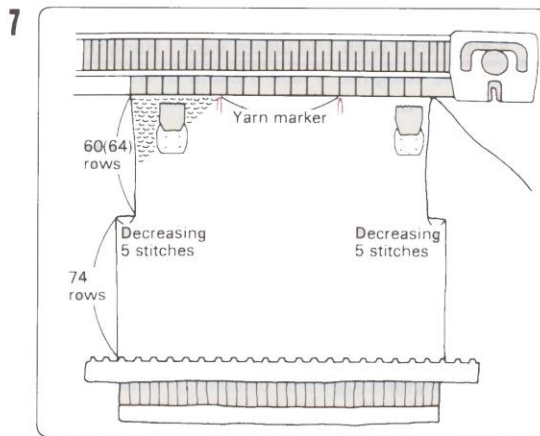

Knit the **BACK** as follows:—

- 1) Knit 74 rows to the underarm. On the same side as the Carriage, cast off 5 stitches. Knit 1 row. On the same side as the Carriage, cast off 5 stitches. *Refer to Decreasing several stitches on page 58.*
- 2) Knit 59(63) rows to the neck edge. The Row Counter reads 134(138).
- 3) Place waste yarn markers on sinker loops between 15(17) and 16(18) on each side of the centre to indicate the neck opening. *Refer to page 19.*
- 4) Change to the waste yarn and knit a few rows. Release the knitting from the machine.

THE FRONT

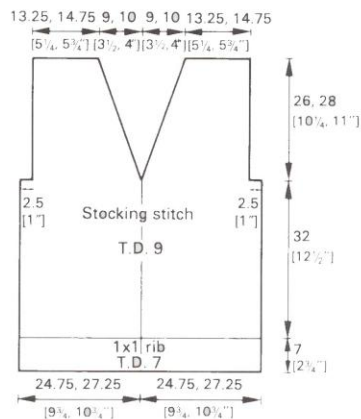

Now you are going to knit 2 pieces for the **FRONT** of the cardigan. You will decrease stitches to form the V shape in the front. First, you will knit the right side of the **FRONT**.

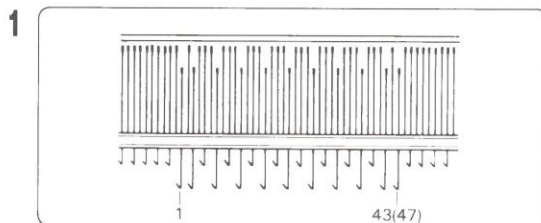

Push every other needle between 2 and 42(46) on the right-hand side into **B** position, and push into **B** position the end needles at both adjacent to needles in **B** position.

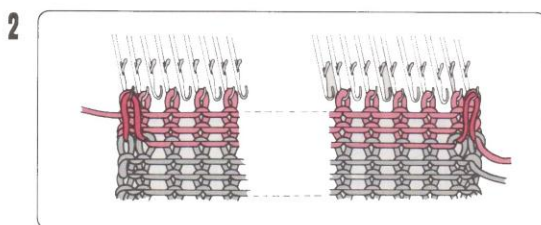

Work 1x1 rib to match the **BACK**. *Refer to steps 2–6.* Make sure that both end loops are hooked on both end needles.

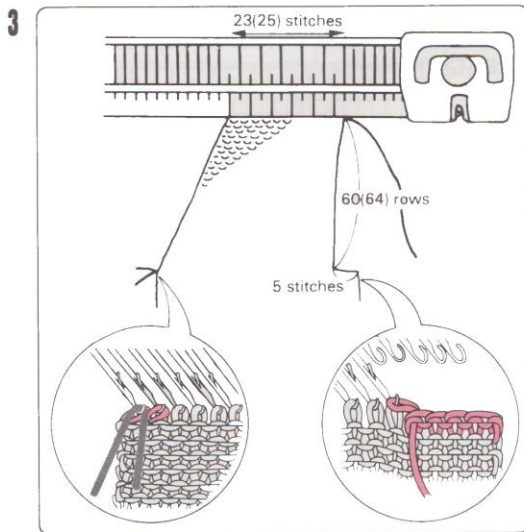

After making 1x1 rib, knit 74 rows to the underarm with Tension Dial 9. The Carriage is on the right.

SHAPING THE NECK OPENING

At the beginning of the next row, cast off 5 stitches to match the BACK. Decrease 1 stitch on the left edge using the 2-eyed Transfer Tool, and place a waste yarn marker. *Refer to page 58 & 18.* Knit 4 rows. Decrease 1 stitch on the left edge every 4 row 14 times until the Row Counter reads 130. (Then for the larger size, decrease 1 stitch every other row 2 times). Knit 4 rows until the Row Counter reads 134(138). 23(25) stitches remain.

Change to the waste yarn. Knit a few rows and release the FRONT from the machine.

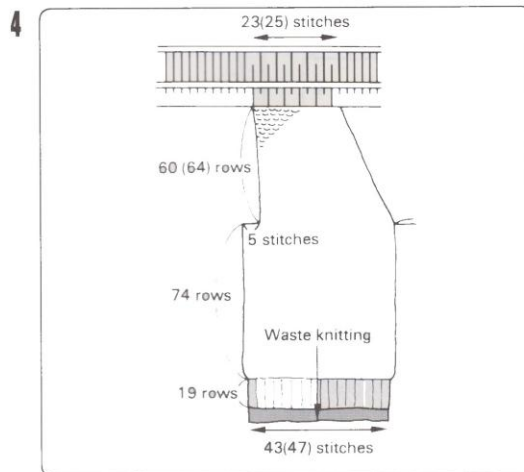

Work the LEFT FRONT to match the RIGHT FRONT reading left as right and vice versa. Make sure that the Carriage kicks the trigger of the Row Counter.

THE SLEEVES

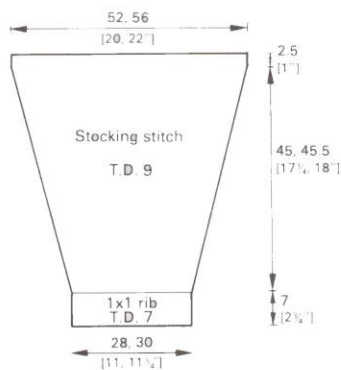

Now you will knit the sleeves. Use the same method to increase stitches as in sweater 2.

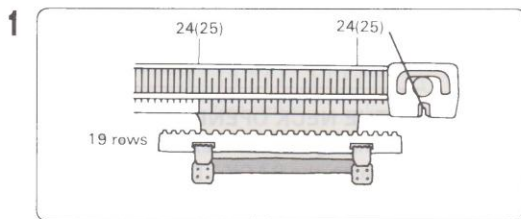

Work the cuff using 48(50) stitches to match the rib of the BACK. *Refer to steps 2 – 6 of the BACK.*

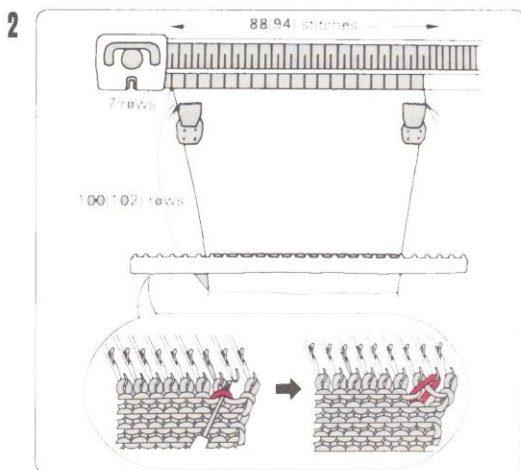

To knit the SLEEVES, knit 4 rows. Increase 1 stitch on each end AT THE SAME TIME. *Refer to fully fashioned method on page 59.* Increase 1 stitch on each end every 4 row 9(14) times until the Row Counter reads 40(60). Then increase 1 stitch on each end every 6 row 10(7) times until the Row Counter reads 100 (102). Put a yarn marker on each end. *Refer to page 18.* Knit 7 rows without increasing. Break the main yarn leaving a length of approximately 3 times the width of the knitting. Change to the waste yarn, knit a few rows and release it from the machine.

THE NECKBAND THE BUTTON BAND THE BUTTON HOLE BAND

Now you are going to make the bands by knitting 3 separate pieces. The bands are knitted in the same manner as the 1x1 rib on the BACK.

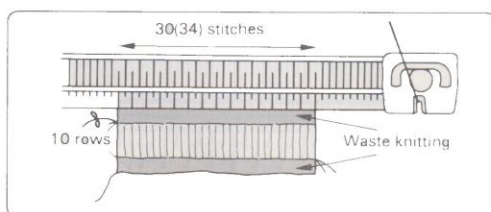

MAKING THE NECKBAND

Cast-on every other needle between needles 15 (17) and 15(17), knit 3 rows Tension Dial 5. Push the empty needles into **B** position. Knit 10 rows, Tension Dial 7. Make the 1x1 rib. Break the yarn leaving the length of approximately 3 times the width of the knitting. Knit a few rows with the waste yarn. Take off the band from the machine.

Remove the waste knitting for casting-on.

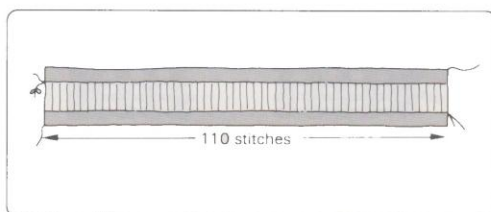

MAKING THE BUTTON BAND

Cast-on every other needle between needles 55 and 55. Knit 3 rows Tension Dial 5. With all needles knit 10 rows, Tension Dial 7. Make the 1x1 rib. Break the yarn leaving the length of approximately 3 times the width of the knitting. Knit a few rows with the waste yarn. Take off the band from the machine.

Remove the waste knitting for casting-on.

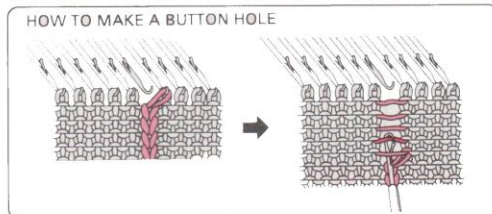
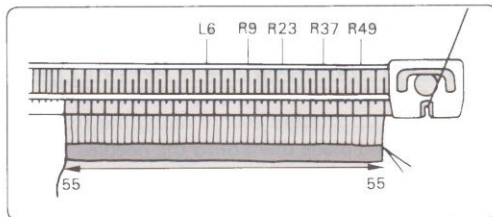

MAKING THE BUTTONHOLE BAND

Cast-on every other needle between needles 55 and 55, knit 3 rows Tension Dial 5. Push the empty needles into **B** position. Knit 5 rows (i.e., half of the band), Tension Dial 7. Decide the buttonhole positions. Make purl stitches at the needles of Left 6 and Right 9, 23, 37 and 49.

Transfer one stitch to its adjacent needle leaving empty needles in **B** position. Knit 5 rows (i.e., the other half of the band). Make the 1x1 rib. Break the yarn leaving the length of approximately 3 times the width of the knitting. Knit a few rows with the waste yarn. Take off the band from the machine.

Remove the waste knitting for casting-on.

MAKE-UP

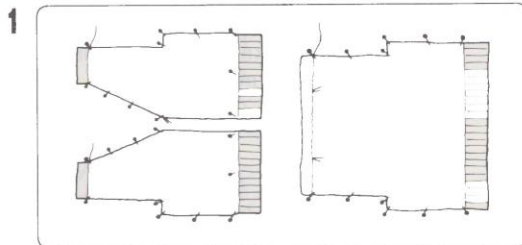

BLOCKING AND PRESSING

Before pressing the knitting, remove the waste knitting which you have used for casting-on.

Refer to page 62. Lay all the pieces of your knitting, wrong side up, on a blocking surface and gently coax into the correct shape and size. Pin the knitting to the surface and press, avoiding the rib. Turn over to the right side and press gently.

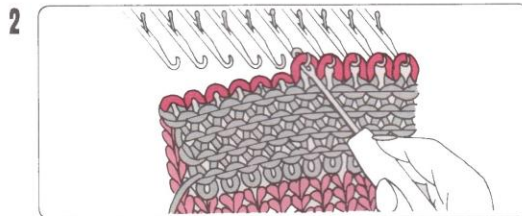

JOINING BOTH SHOULDERS

1) Push 23(25) needles into **B** position. Hold the right side of the **FRONT** facing you. Folding the waste knitting towards you, place the stitches onto the needles.

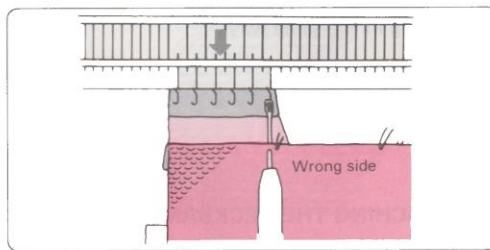

2) Push the needles into **E** position. Hold the wrong side of the **BACK** facing you. Folding the waste knitting away from you, place the stitches onto the hooks of the needles.

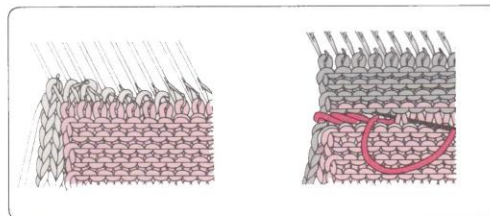

3) Push the needles back to **B** position in order to make a single stitch. Using a Tapestry Needle, bind off the row knitted in the main yarn. *Refer to page 65.* Remove the waste knitting from the shoulder. Join another shoulder in the same way.

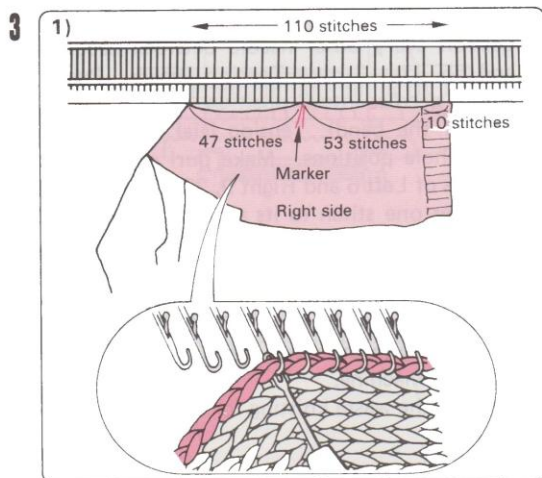

ATTACHING THE BUTTONHOLE BAND TO THE RIGHT FRONT

1) Push 110 needles into B position. With the right side of the right FRONT facing you, pick up stitches evenly along the front opening and place them onto the needles.

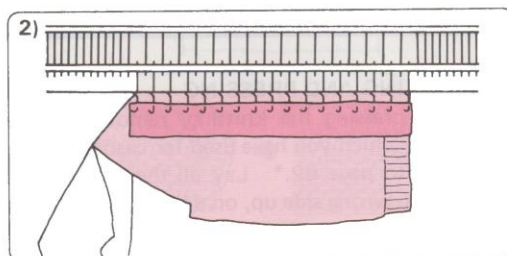

2) Holding the knitting so that it does not come towards you, push the needles into E position. With the wrong side of the BUTTONHOLE BAND facing you, replace the stitches from the last row knitted in the main yarn into the hook of the needles.

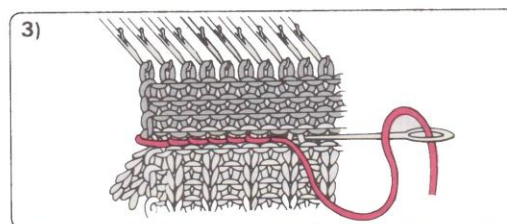

3) Push the needles back to B position in order to make a single stitch. Again push the needles into E position holding the knitting against the needlebed, and knit a few rows with the waste yarn. Using a Tapestry Needle bind off the row knitted in the main yarn. *Refer to page 65.* Remove the waste knitting.

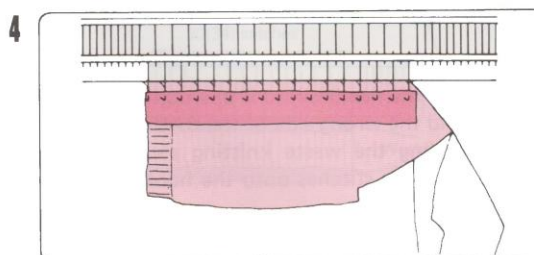

ATTACHING THE BUTTON BAND TO THE LEFT FRONT

Join the BUTTON BAND to the left FRONT opening in the same way.

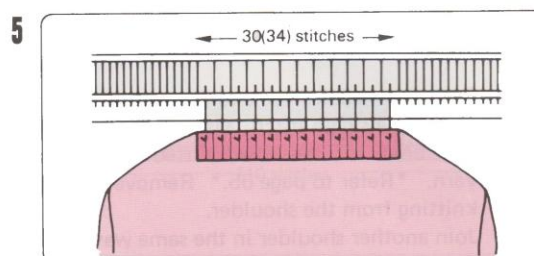

ATTACHING THE NECKBAND TO THE BACK NECK

Push 30(34) needles into B position. Join the NECKBAND to the BACK neck opening in the same way. Remove the waste knitting.

6

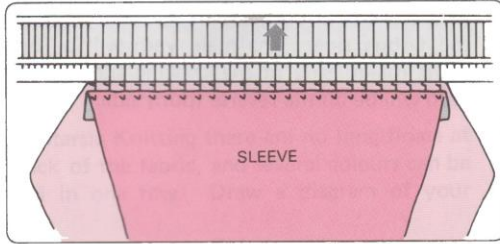
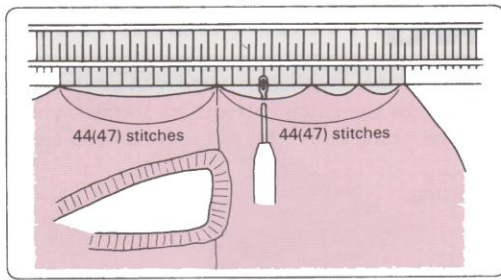

ATTACHING THE SLEEVE TO THE BODICE

- 1) Push 88(94) needles into B position. With the right side of the BODICE facing you, pick up the stitches evenly along the armhole edge and place them onto the needles.
- 2) Holding the knitting so it does not come forward, push the needles into E position. With the wrong side of the SLEEVE head facing you, place the stitches from the last row knitted in the main yarn onto the hook of the needles.
- 3) Push the needles back to B position in order to make a single stitch. Using a Tapestry Needle bind off the last row knitted in the main yarn. *Refer to page 65.* Remove the waste knitting. Attach another sleeve to the bodice in the same way.

7

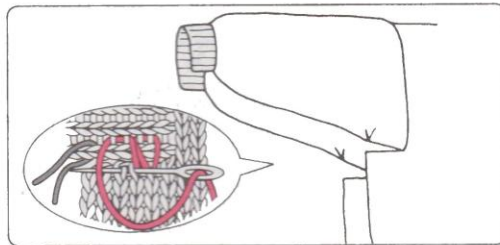

JOINING SEAMS

Using the mattress stitch, join the underarm sleeve to the bodice. The yarn marker on the sleeve should match the underarm seam.

8

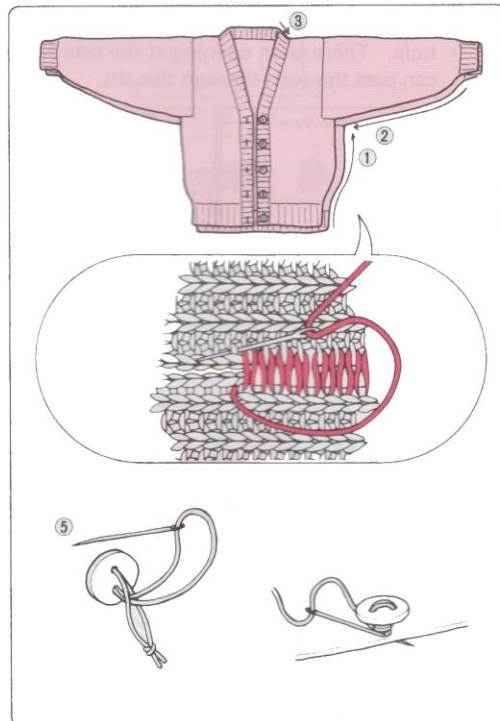

- ① Using the mattress stitch, join the 1x1 rib and the side seams. *Refer to page 66.*
- ② Using the mattress stitch, join the cuffs and the underarm seams.
- ③ Using the mattress stitch, join the band seams.
- ④ Sew in the yarn ends and give it a final press.
- ⑤ Attach the buttons on the BUTTON BAND.

PLATING

The following examples are a guide as to how to knit different types of stitch patterns with your machine. Once you have knitted through the exercises, and you see how the stitch patterns are formed, you will then be able to create your own designs. *Diagram shows the wrong side of the fabric (when you are knitting, the wrong side of the fabric is showing).

Marks (▶◀, ◆) on the needlebed are guide for pattern knitting.



Front (Plain)

Reverse (Purl)

APPROXIMATE TENSION CHART

Gate Pegs	Yarn	Tension Dial Setting
4.5mm pitch	A x A	3-4
4.5mm pitch	A x B	4-5
9mm pitch	B x C	6-8
9mm pitch	C x C	7-10
9mm pitch	C x D	8-13

You can use two yarns to knit a reversible fabric, with one colour on the right side and the other on the wrong side. The main yarn will be on the front (plain) side of the knitting and the plating yarn will be on the reverse (purl) side.

- A : 780-1000m/100g (ultra fine yarn) (average 3ply)
- B : 500-780m/100g (very fine yarn) (average 3ply-4ply)
- C : 300-500m/100g (fine yarn-sports weight yarn) (average 4ply)
- D : 200-300m/100g (worsted weight yarn) (average double knit)

BEFORE KNITTING PLATING ...

- Prepare two yarns – main yarn and plating yarn.
- Exchange the position of the Yarn Tension and the Row Counter.

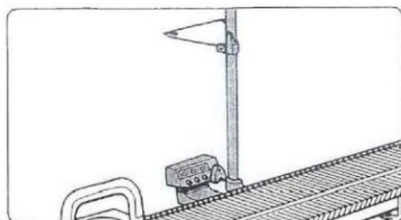

- Remove the Carriage from the needlebed. Put the centre two rubber wheels at the reverse side of the Carriage into non-working position and outer ones into working position pushing them. Replace the Carriage on the needlebed.

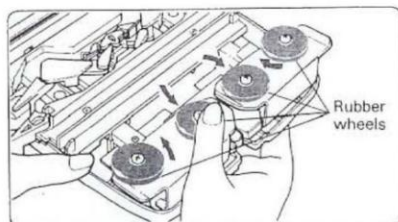

- 1) Knit several rows in main yarn.
- 2) Set the Tension Dial according to the yarn you are using. Refer to the approximate tension chart.

- 3) Pass the end of the plating yarn behind the main yarn.

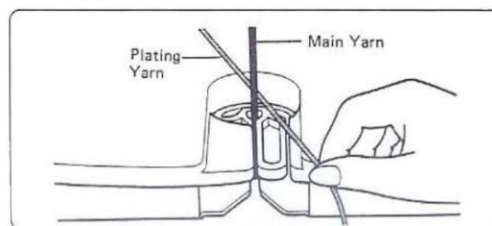

- 4) Thread the plating yarn into the plating yarn hole. There is an opening at the side and you can pass the yarn through this slit.

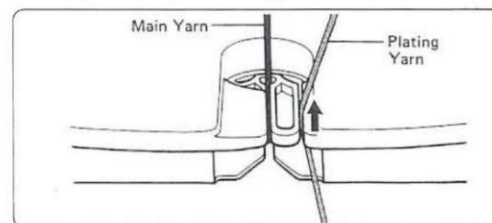

- 5) Make sure yarns are not crossed.

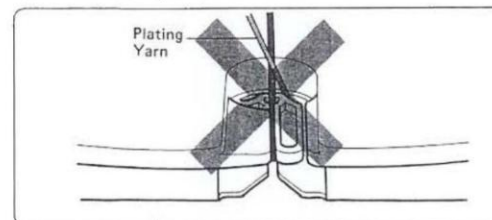

- 6) Continue knitting with main yarn and plating yarn.

2 INTARSIA KNITTING

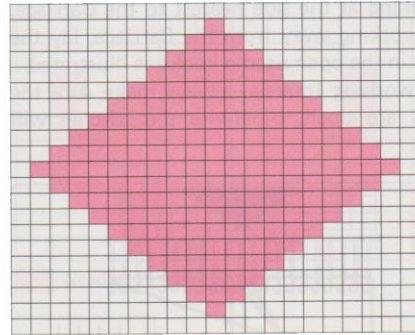
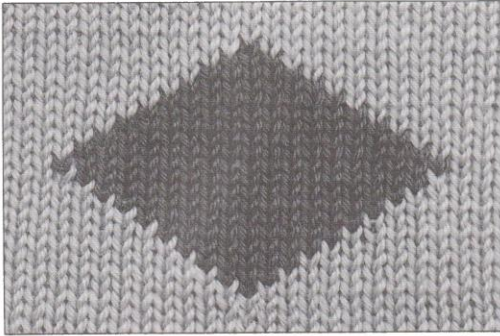

With Intarsia Knitting there are no long floats at the back of the fabric, and several colours can be knitted in one row. Draw a diagram of your design.

When you do Intarsia Knitting, the tension may differ from that of stocking stitch by about 1 number on the Tension Dial (this difference depends on the yarn), therefore bear this difference in mind, and always make a separate tension swatch.

- 1) Knit several rows.
- 2) Cut the yarn and place necessary balls of yarn on the floor at your feet.

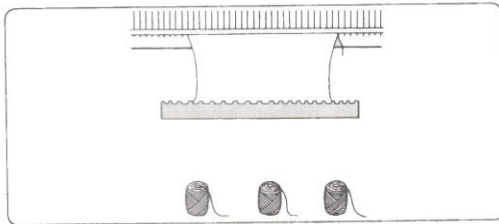

- 3) Prepare sufficient separate balls of yarn according to the changing in the pattern. Using a tapestry needle thread the yarns into the holes in the Sinkers as follows:

- 140–200m/100g
(chunky yarn)
(average thick double knit-chunky and aran)
- 200–300m/100g
(worsted weight yarn)
(average double knit)
- 300–500m/100g
(fine yarn-sports weight yarn)
(average 4ply)
- 500–780m/100g
(very fine yarn)
(average 3ply–4ply)

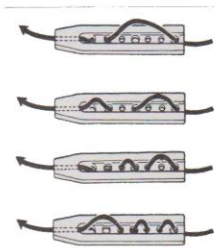

Above instruction is rough guide only and change the hole to be threaded so that the Sinker does not slip off the yarn.

* Do not forget to use the Sinkers.

- 4) Remove the Carriage from the needlebed. Put the centre two rubber wheels at the reverse side of the Carriage into working position and outer ones into non-working position pushing them. Replace the Carriage on the needlebed.

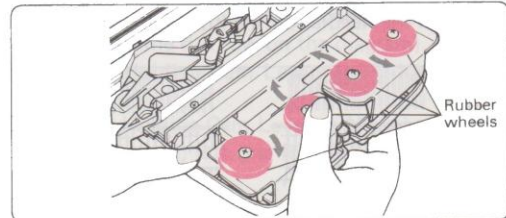

- 5) Set the Change Lever to INTAR.
- 6) Move the Carriage without knitting to align the needles in D position.

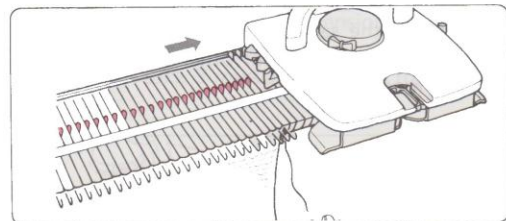

- 7) Beginning at the side nearest to the Carriage, and working away from the Carriage, lay the yarns in the open needle hooks as illustrated.
- * When working Intarsia, always make sure the latches are open, otherwise the stitches will drop.

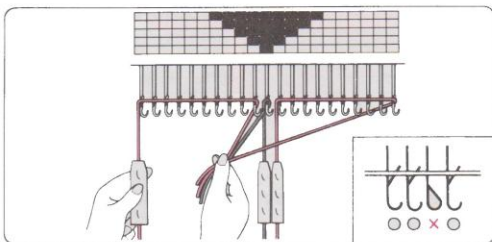

- * As the yarns will be taken up by the formation of the stitches, slide the Sinkers sufficiently far down the yarns to prevent them being caught up on the needles during knitting.

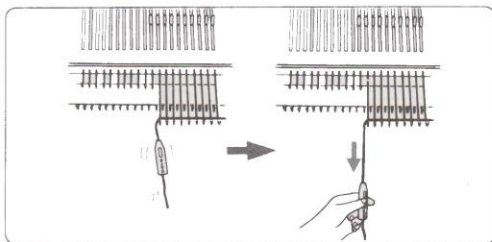

- 8) Move the Carriage slowly across the needle bed, at the same time gently pull the yarns downwards with your other hand to take up any looseness.

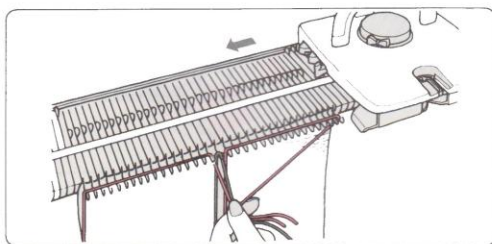

- 9) Working in the opposite direction (again away from the Carriage) lay the yarns in the open needle hooks for the next row. To avoid a hole appearing where the yarns meet, cross one over the other as illustrated. Now slowly move the Carriage across the needlebed.

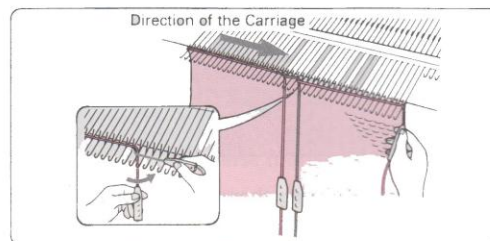

- 10) Lay the yarns and knit the third row. Continue knitting in this way, laying your yarns according to your pattern chart. (Repeat steps 7) – 8)).

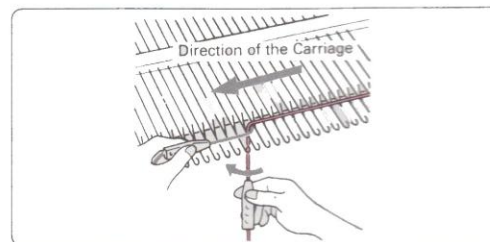

- 11) After completing Intarsia knitting, place the centre two rubber wheels in non-working position and outer rubber wheels into working position.

- * Do not operate the Carriage (with the Change Lever at INTAR) without yarn as there is fear of doing damage to the needles.

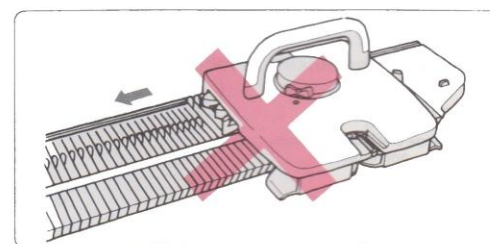

3 PULL-UP STITCH PATTERN (TUCK STITCH PATTERN)

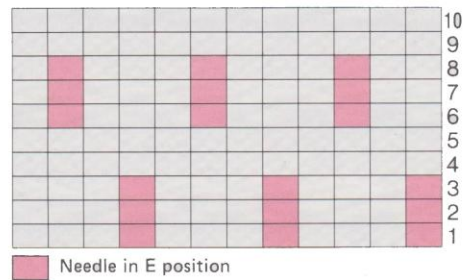
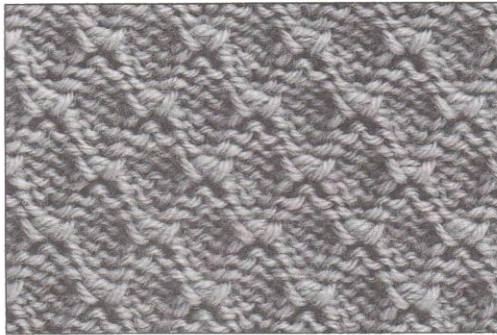

- 1) Knit several rows.
- 2) With the Needle Pusher 1 x 3, bring forward every 4th needle to E position holding the knitting so that it does not come towards you (Refer to the 1st row on the diagram).
- * You cannot tuck on the end needle.
- 3) Set the Holding Cam Levers to H. Knit three rows.

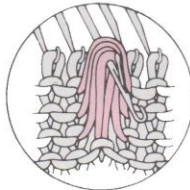

Yarn is held on those needles in E position.

- 4) Set the Holding Cam Lever to N (right one for the rightward, left one for the leftward movement).

- 5) Knit two rows.
- 6) With the Needle Pusher 1 x 3, bring forward every 4th needle to E position holding the knitting so that it does not come towards you (Refer to the 6th row on the diagram).
- 7) Set the Holding Cam Levers to H. Knit three rows.
- 8) Set the Holding Cam Lever to N (right one for the rightward, left one for the leftward movement).
- 9) Knit two rows.
- 10) Repeat steps 2) – 9).

NOTE:

Rehang the Cast-on Comb and Claw Weight every 20 rows or so to give an even tension. You cannot tuck more than 3 rows on one needle. You may not tuck 3 rows according to the yarn.

4 SKIP STITCH PATTERN

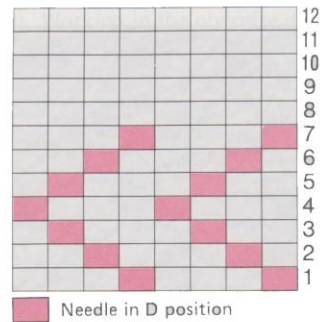

Needle in D position

- 1) Knit several rows.
 - 2) With the Needle Pusher 1 x 3, bring forward every 4th needle to D position holding the knitting so that it does not come towards you (Refer to the 1st row on the diagram).
 - 3) Set the Change Lever to PART. Knit one row.
 - 4) With the NeedlePusher 1 x 3, bring forward the needles next to ones you selected in step 2) holding the knitting so that it does not come towards you (Refer to the 2nd row on the diagram). Knit one row.
 - 5) Selecting the needles according to the diagram, continue knitting until you have knitted 7 rows.
 - 6) Set the Change Lever to PLAIN and knit 5 rows in stocking stitch.
 - 7) Repeat steps 2) – 6).
- NOTE:**
When the Change Lever is set to PART, only needles in D and E position will knit.

5 MULTI-COLOUR SKIP STITCH PATTERN

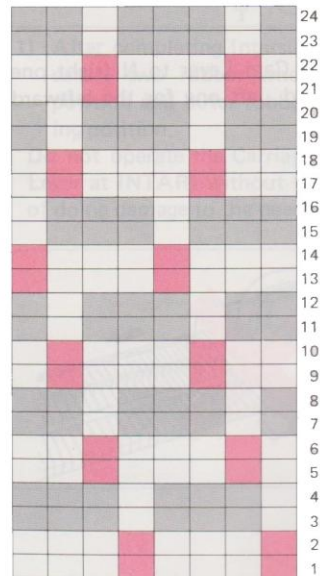

Knit in contrast yarn. (Needle in D position)

Knit in main yarn. (Needle in D position)

Prepare two yarns-main yarn and contrast yarn.

- 1) Knit several rows.
- 2) Set the Change Lever to PART.
- 3) Hold the knitting so that it does not come towards you. Bring forward the needles to D position according to the 1st row of the diagram.

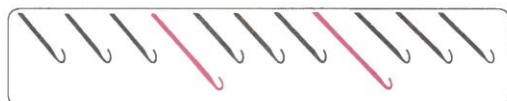

- 4) Knit one row in contrast yarn.
- 5) Hold the knitting so that it does not come towards you. Bring forward the needles to D position according to the 2nd row of the diagram and knit one row with contrast yarn.

- 6) Hold the knitting so that it does not come towards you. Bring forward the needles to D position according to the 3rd row of the diagram.

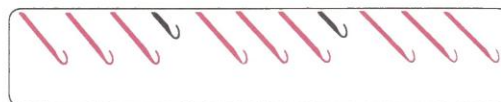

- 7) Knit one row in main yarn.
- 8) Hold the knitting so that it does not come towards you. Bring forward the needles to D position according to 4th row of the diagram and knit one row in main yarn.
- 9) Selecting the needles according to the diagram, continue knitting in yarns indicated on the diagram.

NOTE:

When the Change Lever is set to PART, only needles in D and E position will knit.

6 LACE PATTERN



- 1) Knit several rows.
- 2) Transfer the stitches according to the first row of the diagram using the Transfer Tool.
* Refer to "How to transfer stitches" on page 56.*

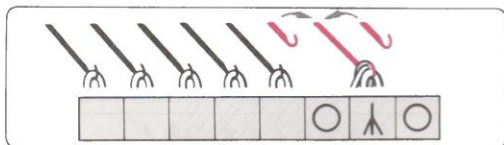

- 3) Make sure that all the needles are in B position. Knit two rows.

															16	
○														○	▲	15
																14
▲	○														○	13
																12
○	▲	○														11
																10
																9
																8
																7
																6
																5
																4
																3
																2
																1

- 4) Transfer the stitches according to the 3rd row of the diagram.

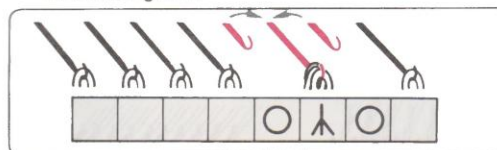

- 5) Make sure that all the needles are in B position. Knit two rows.
- 6) Transfer the stitches according to the diagram, continue in lace stitch pattern.

NOTE:

If you cannot knit smoothly, bring forward the needles which have transferred stitches to E position.

7 KNIT & PURL STITCH PATTERN

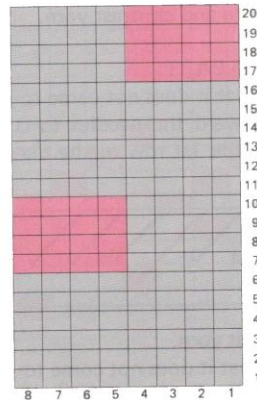

Purl stitch
 Plain stitch

Purl stitches are worked with the Latchet Tool.

- 1) Knit ten rows.
- 2) Bring forward marked needle (5) on 10th row in the diagram to E position, then push it back to B position. The stitch will drop off the needle. Let the stitch run down the number of rows needed for each purl stitch.

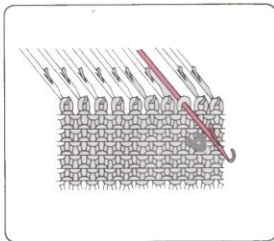

- 3) Using the Latchet Tool pick up the stitch (one row below where the purl stitches will begin) (6th row, see the diagram).

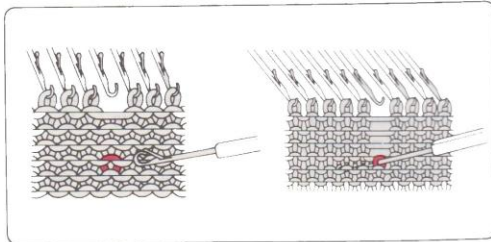

- 4) Catch the next horizontal bar above with the hook of the Latchet Tool with first stitch behind the latch. Then pull the Latchet Tool towards you. A purl stitch has been formed.

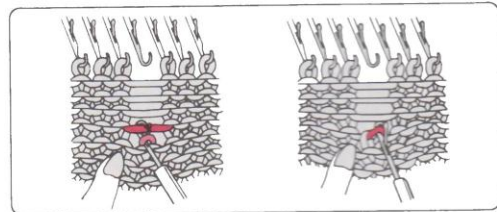

- 5) Continue in this way until you reach the last stitch. Hook the last stitch onto the needle.

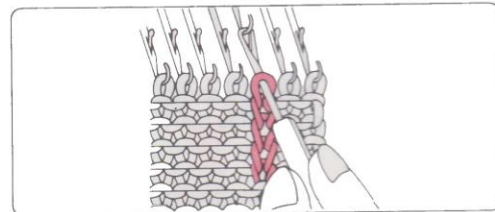

- 6) Repeat the above steps making the purl stitches according to the diagram.

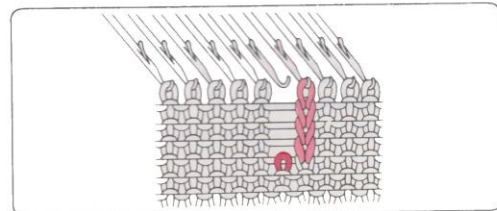

BASIC TECHNIQUES FOR MAKING GARMENTS

1 HOW TO USE THE TRANSFER TOOL

Use when you decrease, increase, transfer stitches, etc.

How to hold the Transfer Tool

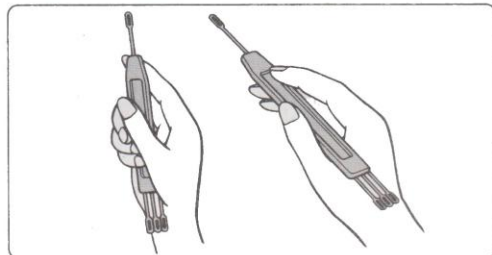

Transferring stitches

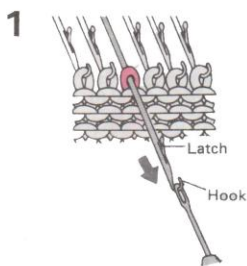

Place the eye of a single Transfer Tool over the needle hook, and pull the needle towards you until stitch passes behind the latch.

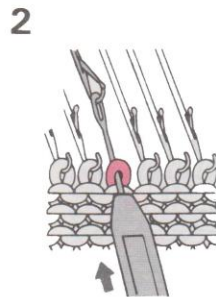

Holding the Transfer Tool in line with the needle, use it to push the needle back so that the stitch slips onto the Transfer Tool.

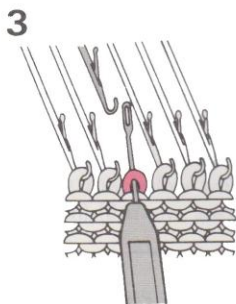

Lift the Transfer Tool together with the stitch, and place it onto the adjacent needle.

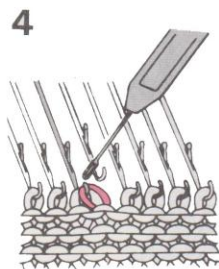

Lift the handle of the Transfer Tool slightly so that the stitch slides off into the hook of the needle. Then remove the Transfer Tool. One stitch has been transferred.

2 HOW TO USE THE LATCHET TOOL

Use the Latchet Tool when you work a welt, pick up dropped stitches, etc.

How to hold the Latchet Tool

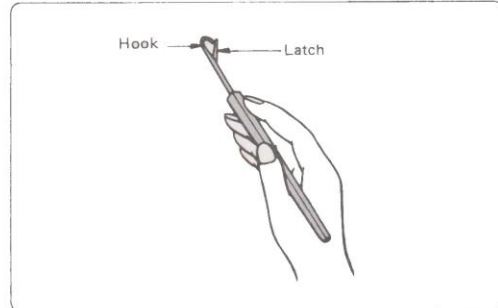

Making a welt by hand

1

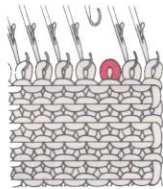

Bring the needle for "purl" stitch forward to E position and then back to B position so that the stitch drops off the needle.

2

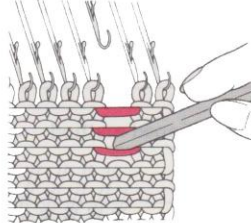

Using the end of your Latchet Tool, ladder the stitch down to within a few rows of the point where you want to start the welt.

3

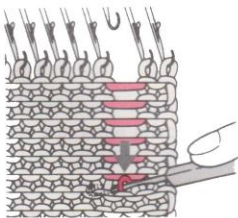

Hook the first stitch where the welt will begin and push down with the Latchet Tool so that the last few stitches drop.

4



Push the Latchet Tool forward to put the first stitch behind the latch and catch the next horizontal bar above with the Latchet Tool. Pull the Latchet Tool towards you.

5

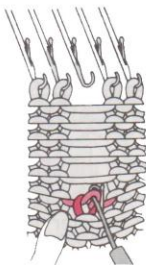

The latch closes with a new stitch in the hook. Gently slip the old stitch off the end of the Latchet Tool.

6

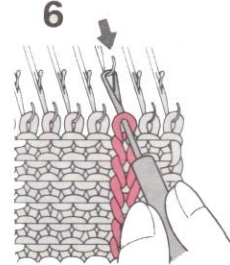

Continue in this way until you reach the top, then hook the last stitch onto the needle as shown.

3 DECREASING STITCHES

Use the Transfer Tool.

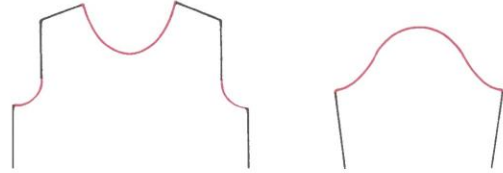

Decreasing one stitch . . . simple method

<p>Remove one stitch at the edge onto your Transfer Tool.</p>	<p>Place the Transfer Tool onto the hook of the adjacent inside needle, and transfer the stitch.</p>	<p>Return the empty needle to A position.</p>

Decreasing one stitch . . . fully fashioned method.

<p>Remove two stitches at the edge using a 2 eyed Transfer Tool.</p>	<p>Place the Transfer Tool onto the hooks of the adjacent inside needles, and transfer the stitches.</p>	<p>Return the empty needle to A position.</p>

Decreasing several stitches

Carriage and yarn are at the side where you wish to decrease the stitches.

<p>On the Carriage side transfer the end stitch onto the adjacent needle.</p>	<p>Bring this needle forward and loop the yarn around the needle hook.</p>	<p>Push the needle back so that a single stitch is formed. Return the empty needle to A position.</p>	<p>Repeat the same steps, but on the last stitch only transfer the stitch.</p>
<p>Take care not to pull the yarn too hard, or the cast off edge will become too tight.</p>			

4 INCREASING STITCHES

Use the Transfer Tool.

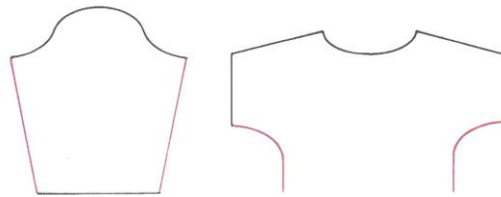

Increasing one stitch . . . simple method

The Carriage and yarn are at the side where you wish to increase the stitch.

On the Carriage side, bring one edge needle forward from A to B position.

Knit one row to the left. The empty needle picks up the yarn.

Knit one row to the right. The new stitch knits.

Increasing one stitch . . . fully fashioned method

The Carriage can be at either end of the needlebed.

Using the Transfer Tool, transfer the edge stitch to the adjacent outside empty needle (the second needle becomes empty).

Pick up the horizontal loop from the lower row of the second stitch, from the end.

Place this loop onto the empty needle and continue to knit.

Increasing several stitches.

The Carriage and the yarn are at the side where you wish to increase the stitches.

Bring the needles to be increased forward to E position.

Wind the yarn loosely around the stem of each needle as shown.

Knit one row pulling up any loose yarn with your hand. Knit two or three rows after pulling the needles containing the new stitches to E position.

5 PARTIAL KNITTING

■ DECREASING STITCHES

Work decreases for shoulder, neck opening, etc.
This example shows shoulders.

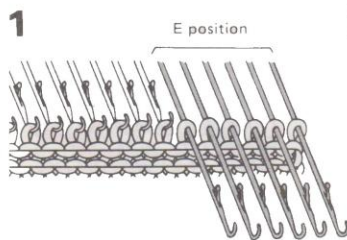
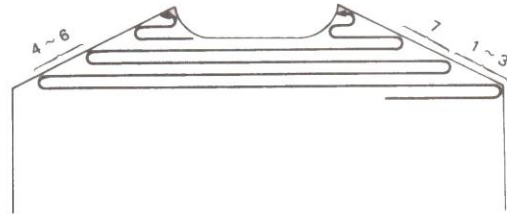

1 Set the Holding Cam Levers to H. On the opposite side to the Carriage, bring the needles you want to decrease forward to E position.

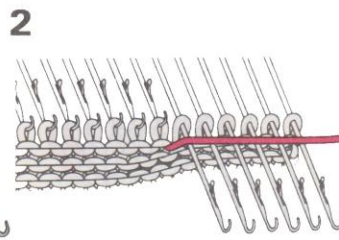

2 Knit one row. The needles in E position have not been knitted.

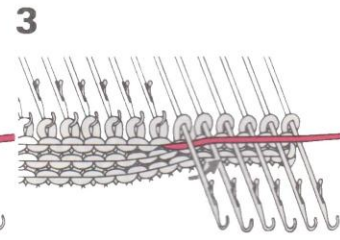

3 Pass the yarn under the stem of the first needle in E position.

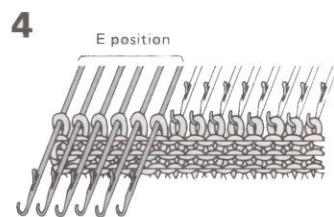

4 On the opposite side to the Carriage, bring the needles you want to decrease forward to E position.

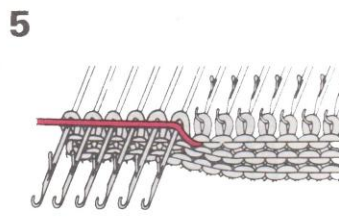

5 Knit one row. The needles in E position have not been knitted.

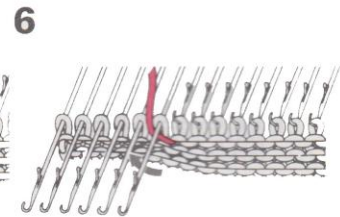

6 Pass the yarn under the stem of the first needle in E position.

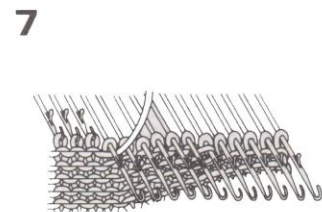

7

When you want to knit all the needles after partial knitting, return the Holding Cam Levers to N. When the Holding Cam Lever is set to H, needles in E position are not knit.

Therefore, if you have brought forward the needles to E position to knit smoothly or to knit pull up stitch pattern, push them back to D position.

Repeat the steps 1 – 6.

■ INCREASING STITCHES

Work increases for hemline of a skirt, dart, etc.
This example shows the hemline.

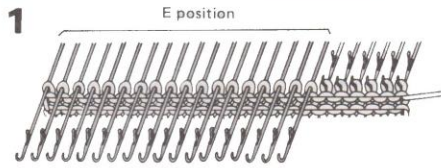
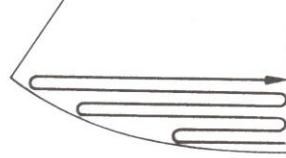

Set the Holding Cam Levers to H. On the opposite side to Carriage, bring forward to E position those needles that you do not want to knit.

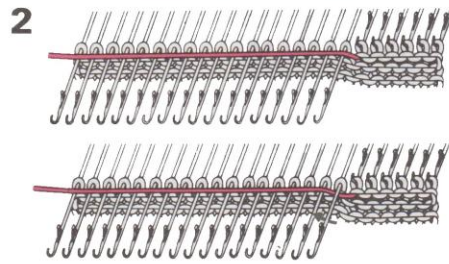

Knit one row. Pass the yarn under the stem of the first needle in E position.

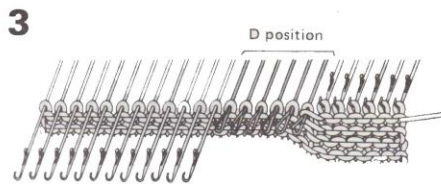

Knit one row and push the needles to be increased from E to D position.

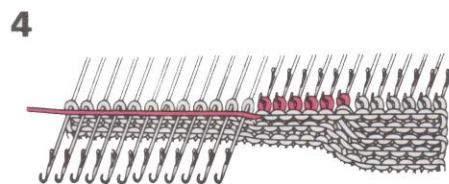

Knit one row. Pass the yarn under the stem of the first needle in E position. Repeat steps 3 – 4. When you want to knit all the needles after partial knitting, return the Holding Cam Levers to N.

When the Holding Cam Lever is set to H, needles in E position are not knit. Therefore, if you have brought forward the needles to E position to knit smoothly or to knit pull-up stitch pattern, push them back to D position.

6 WASTE KNITTING

Waste knitting is the term used to describe knitting that will be removed when the garment is completed, or to enable you to carry out the next step.

■ CASTING-ON

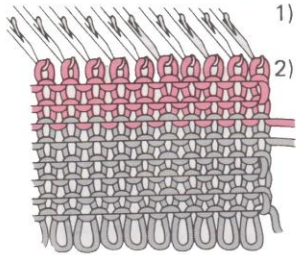

- 1) Knit several rows in waste yarn.
- 2) Unthread the waste yarn and knit in main yarn.

■ CASTING-OFF

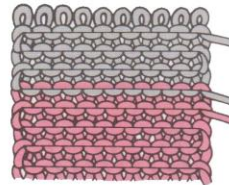

- 1) After the main yarn knitting, unthread the main yarn and knit several rows in waste yarn.
- 2) Run the empty Carriage across the needles to remove the knitting.

Waste yarn is a smooth yarn in a different colour to that of the main yarn, and of a similar thickness to that of main yarn.

7 BACK STITCH

Hold the knitting with the wrong side facing you and fold the waste knitting away from you. Then follow the steps below.

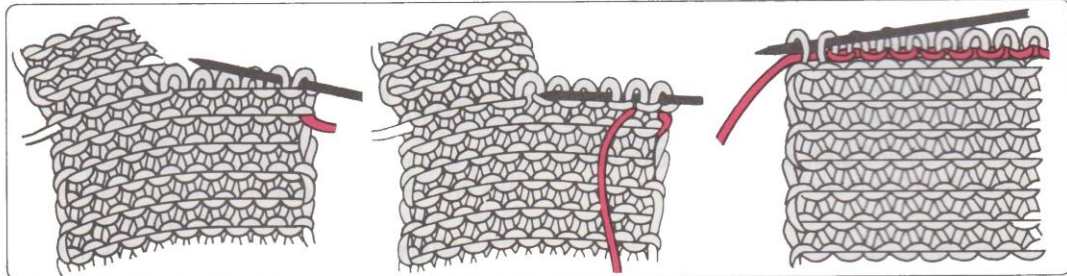

8 REMOVING THE WASTE KNITTING

Just after binding off is completed waste knitting can be unravelled.

* Waste knitting for casting-on is difficult to remove, so cut the end stitch of the last row of waste knitting, and then pull yarn end.

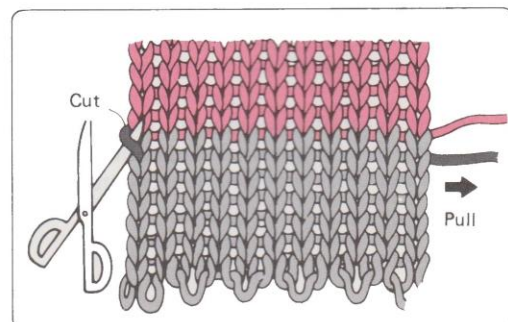

9 CASTING-OFF

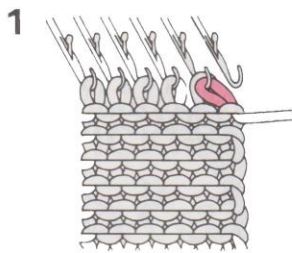
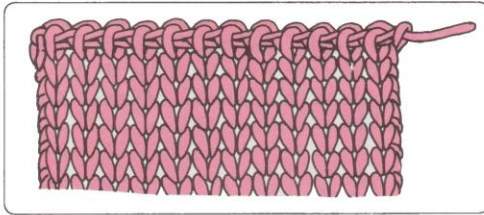

1
On the same side as the Carriage, transfer the end stitch to the 2nd needle.

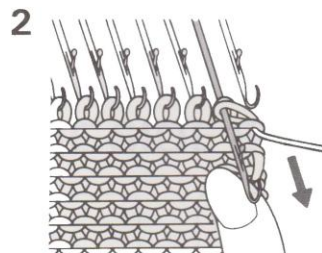

2
Bring forward the needle with two stitches to E position.

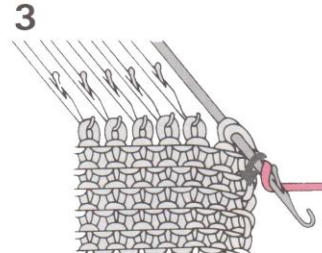

3
Loop the yarn around the stem behind the latch, anticlockwise.

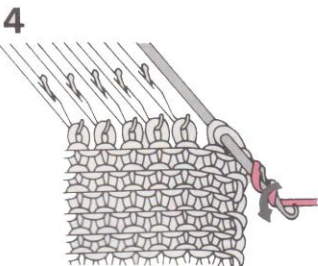

4
Now loop the yarn around the hook of the needle.

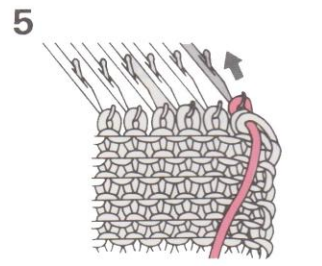

5
Push back the needle to B position.

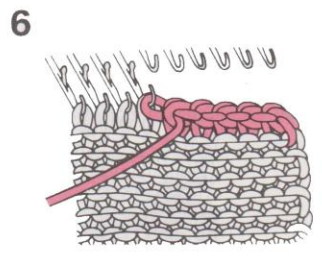

6
Repeat steps 1–5 until cast off edge has been completed.

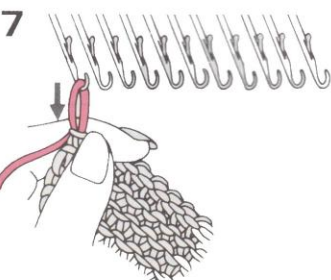

7
Break yarn and pull end through loop of the last stitch. Return all empty needles to A position.

10 BINDING OFF FOR FINISHED EDGE

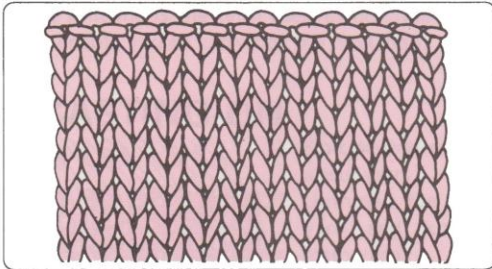

The yarn is on the left-hand side. Take yarn out of the Yarn Feeder and cut it leaving a length three times the width of the knitting. (If the yarn is on the right, use another strip of yarn.) Knit a few rows in waste yarn.

<p>1</p> <p>(1)(2)</p>	<p>2</p> <p>(1)(2)</p>
<p>Thread yarn end into a Tapestry Needle. From the back, pass needle through the first stitch at the left (1).</p>	<p>From the front, insert the needle in through the second stitch (2) and back out through the first stitch (1).</p>
<p>3</p> <p>(2)(3)</p>	<p>4</p> <p>(2)(3)</p>
<p>From the front, insert the needle in through the third stitch (3) and back out through the second stitch (2).</p>	<p>Continue in this way until you reach the right-hand edge of the knitting. After releasing the knitting from the machine, remove the waste knitting.</p>

11 PICKING UP THE STITCHES

From the wrong side

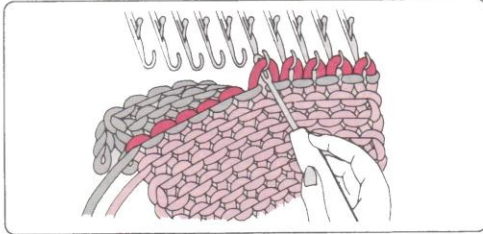

Fold the waste knitting towards the machine.

From the right side

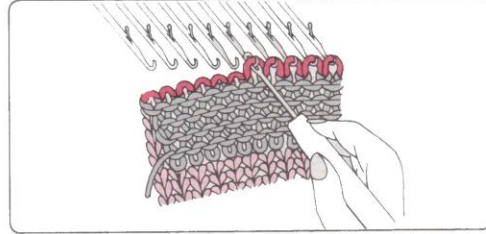

Fold the waste knitting towards you.

12 PICKING UP THE SIDE EDGE STITCHES

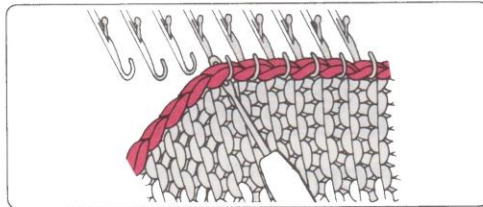

Pick up the edge stitches with the Transfer Tool and hook them onto the hooks of the needles.

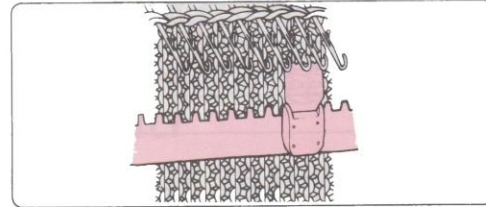

Bring forward the needles to E position holding the knitting so that it does not come towards you. Hang the Cast-on Comb and Claw Weights and knit.

13 BINDING OFF ON THE MACHINE TO JOIN THE KNITTING

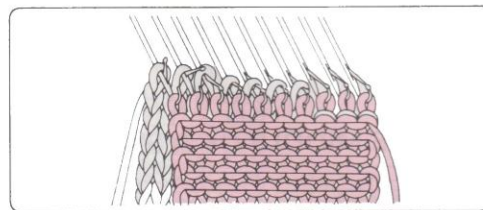

Pick up all the stitches of the first swatch with its right side facing you. All the stitches of the second swatch with its wrong side facing you and push back all of the first swatch stitches behind the latches. Pass all the stitches over the latches of the needles to make a single stitch.

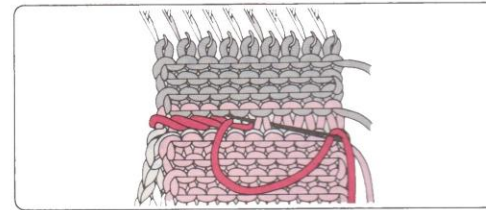

Knit a few rows in waste yarn. Bind off all stitches with the Tapestry Needle referring to page 64.

* If the yarn is on the right, use another strip of yarn. After releasing the knitting from the machine, remove the waste knitting.

14 SEAMING

■ STOCKING STITCH

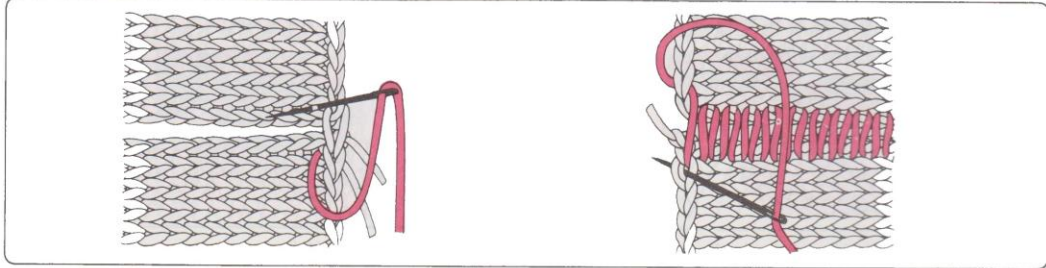

■ 2x1 WELT

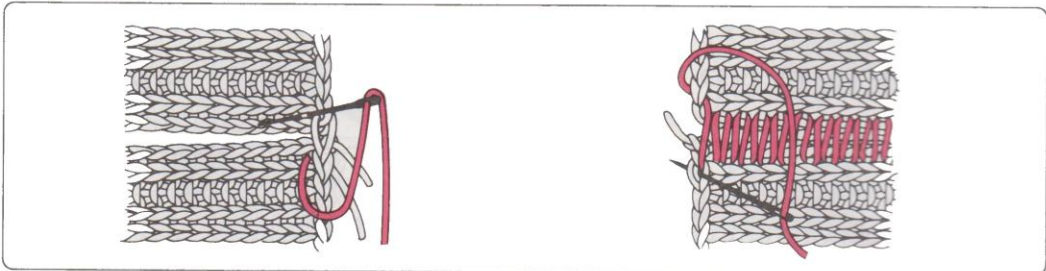

■ EDGE WHERE YOU INCREASE STITCHES

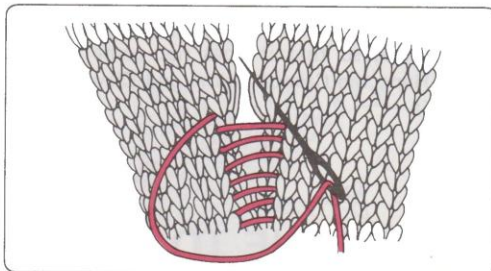

15 FINISHING

■ ON THE EDGE OF A SWATCH

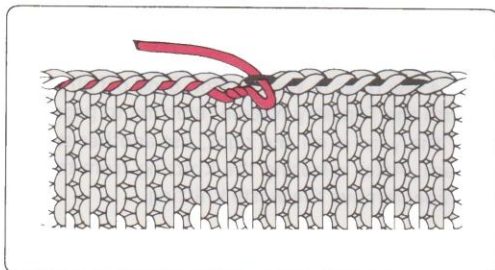

■ IN THE MIDDLE OF A SWATCH

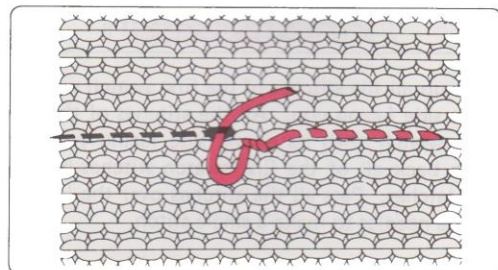

USEFUL HINTS (PROBLEMS DURING KNITTING)

1 WHAT TO DO WHEN YOU CANNOT KNIT SMOOTHLY

■ WHEN THE NEEDLES DO NOT CATCH THE YARN CORRECTLY

- Is the yarn correctly located in the Yarn Feeder ?
- Is the Carriage set correctly on the needlebed ?
- Are the Change Lever set to PLAIN ?
- Are the Holding Cam Levers set to N ?
- Make sure that the yarn is flowing freely from the cone or ball.

■ WHEN THE CARRIAGE IS HARD TO PUSH BACK AND FORTH

- Make sure that the Tension Dial is adjusted according to the thickness of your yarn (See page 5).
- Make sure that the yarn is flowing freely from the cone or ball.
- Is the Carriage knocking against the butt of a needle ? If so, arrange the needle to the proper position.
- Are there any knots in the yarn ?
- Does the machine need oiling ? (See page 72.)

■ WHEN STITCHES ARE NOT FORMED CORRECTLY

- Is the needle bent ? If so, change it for a new one (see page 72).
- If you move the Carriage far beyond the knitting, end stitches are apt to drop because of the loose tension. Therefore do not move the Carriage too far beyond the knitting.
- Rehang the Cast-on Comb when the knitting becomes long. Rehang the Claw Weights onto the edge of the knitting.

2 HOW TO PICK UP A DROPPED STITCH

■ REPAIRING A DROPPED STITCH

Insert the Transfer Tool into the stitches on the row below the dropped stitch as illustrated.

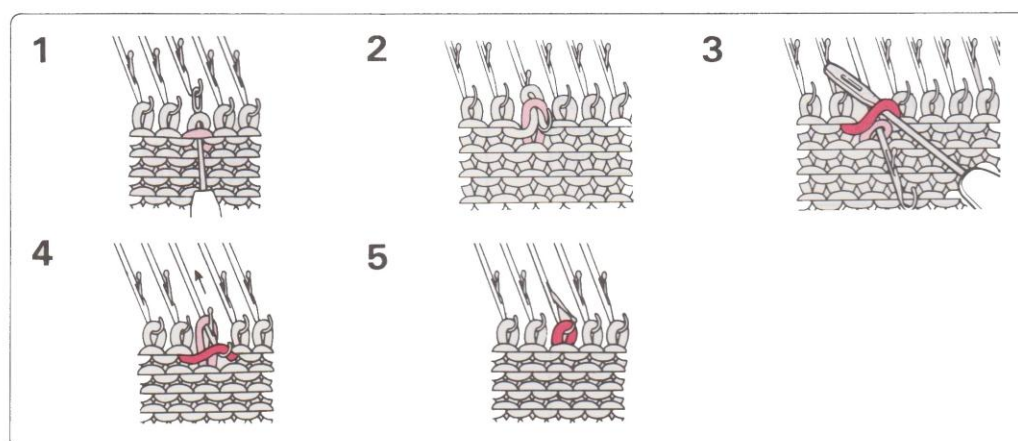

■ REPAIRING A DROPPED STITCH THAT HAS DROPPED SEVERAL ROWS

Use the Latchet Tool from behind, and hook up the first stitch. Remake the dropped stitches row by row. On the final row, transfer the stitch from the Latchet Tool to a Transfer Tool, and replace it onto the needle.

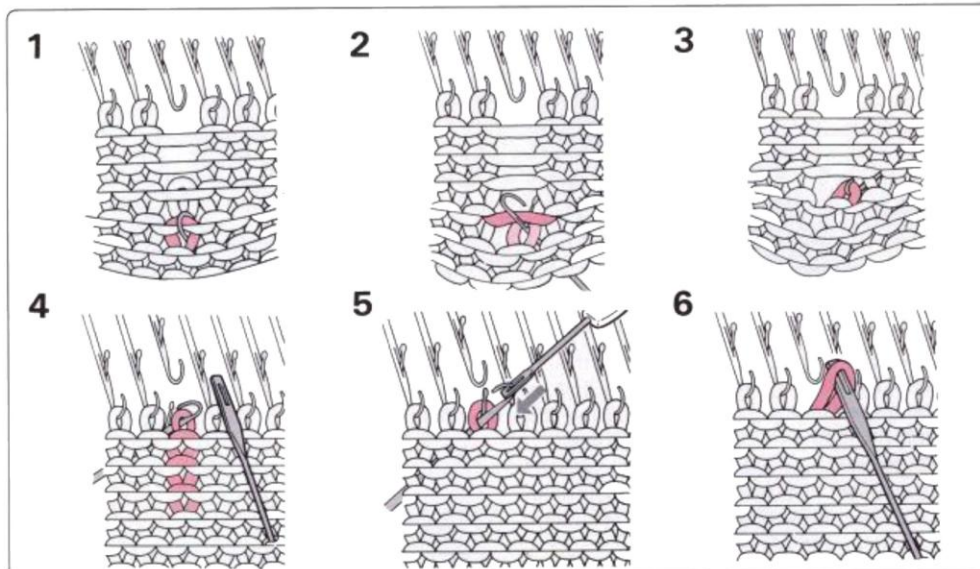

3 WHAT TO DO IF YOU MAKE MISTAKES AS YOU KNIT

■ IF THE CARRIAGE SHOULD JAM

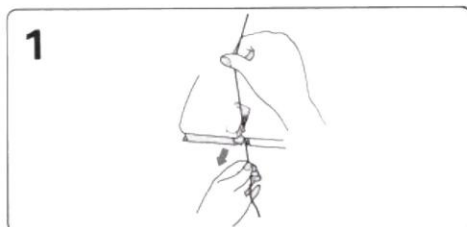

Take the yarn out of Yarn Feeder.

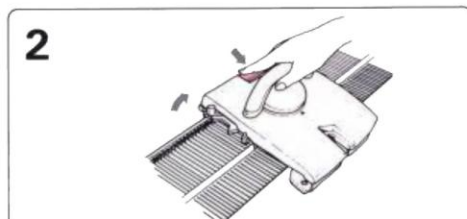

Push the Carriage Release Button and lift up the Carriage towards you to remove the Carriage from the needlebed.

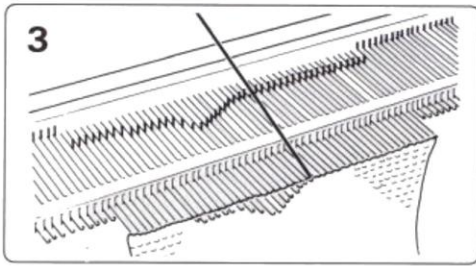

Using your Transfer Tool, replace any stitches that are on the stems of the needles back into the hooks, so that they will not drop off (the following steps illustrate this technique).

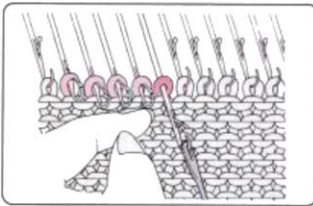

Place the eye of the Transfer Tool into the hook of the needle. Hold the Transfer Tool in line with the needle and pull it towards you.

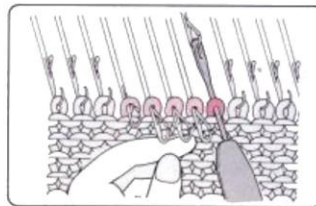

Push the Transfer Tool away from you towards the machine until the stitch is on the Transfer Tool.

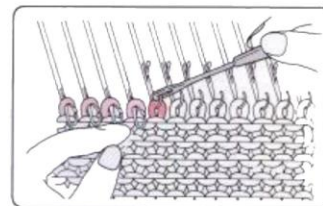

Transfer the stitch into the hook of the needle.

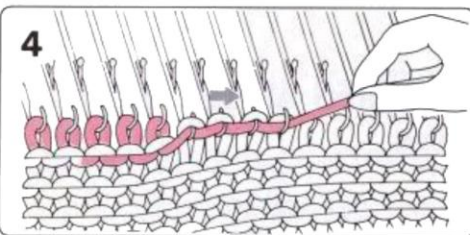

When all stitches are safely in the hooks of the needles, align all needles in B position using the Needle Pusher.

Pull the yarn sideways slightly so that it becomes tight in the needle hooks.

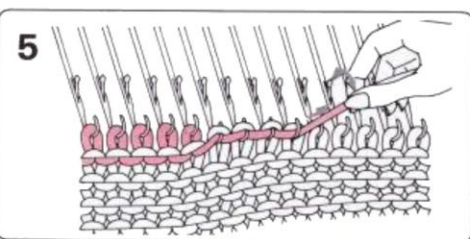

Now pull the yarn in an upwards direction to unravel the knitting. The stitches are undone and those from the row below will slip into the needle hooks. Work a few stitches at a time and repeat steps 4 – 5 across the row.

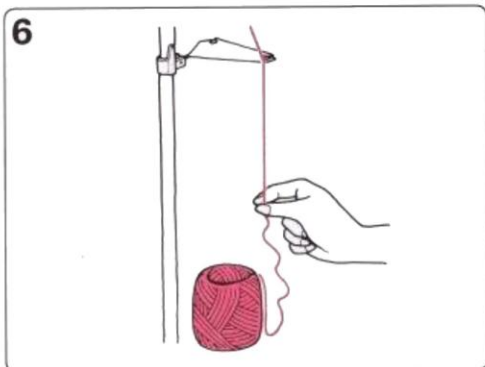

Pull down the loose unravelled yarn from behind the Rear Yarn Guide.
To unravel several rows of knitting, repeat steps 4 – 6.

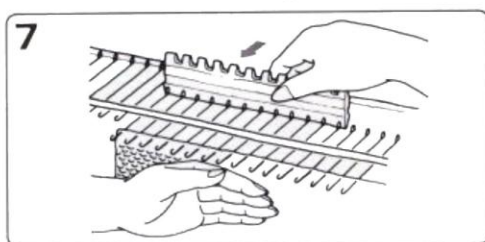

Bring forward the needles to E position holding the knitting so that it does not come towards you. Wind back the Row Counter the number of rows you have unravelled.

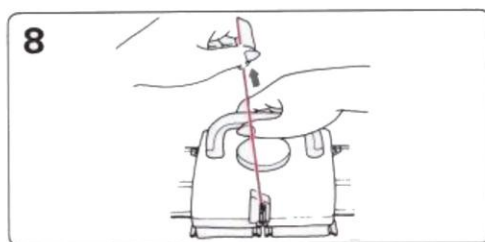

Thread the yarn into the Yarn Feeder. Continue knitting with the Carriage, pulling the yarn slightly on the first row to remove any slackness.

■ IF YOU WANT TO UNRAVEL SOME KNITTING

Should you wish to unravel a row or rows of knitting, if for example you find you have knitted too many, follow steps 4 – 8.

4 WHAT TO DO IF YOU MAKE MISTAKES AS YOU KINT (INTARSIA)

■ IF THE CARRIAGE SHOULD JAM

1 Follow the steps 2–5 on pages 68 – 69.

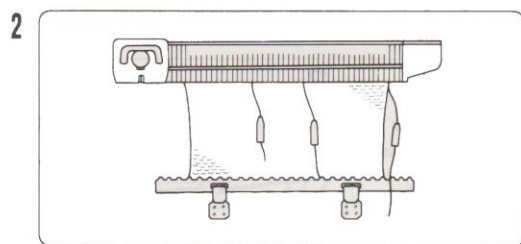

Put the Carriage at the opposite side to the yarn end.

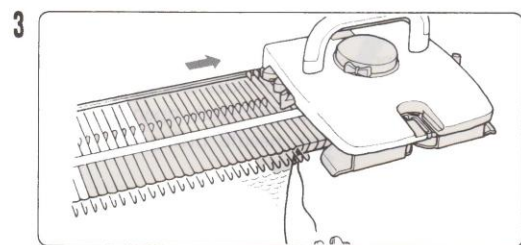

Make sure all the needles are in B position. Move the Carriage to align the needles in D position.

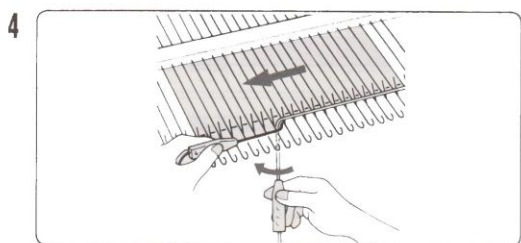

Lay the yarns in the needle hooks and continue intarsia knitting.

■ IF YOU WANT TO UNRAVEL SOME KNITTING

Should you wish to unravel a row or rows of knitting, if for example you find you have knitted too many, follow steps 3 – 5 on page 69 and then 2 – 4 on this page.

LOOKING AFTER YOUR MACHINE

1 REPLACING A NEEDLE

Needles that are bent, broken or damaged will cause problems during knitting.

If you experience dropped or badly knitted stitches you should check the needles and replace any faulty ones immediately. In an emergency if you have no spare needles, use one from the extreme edge of the needlebed.

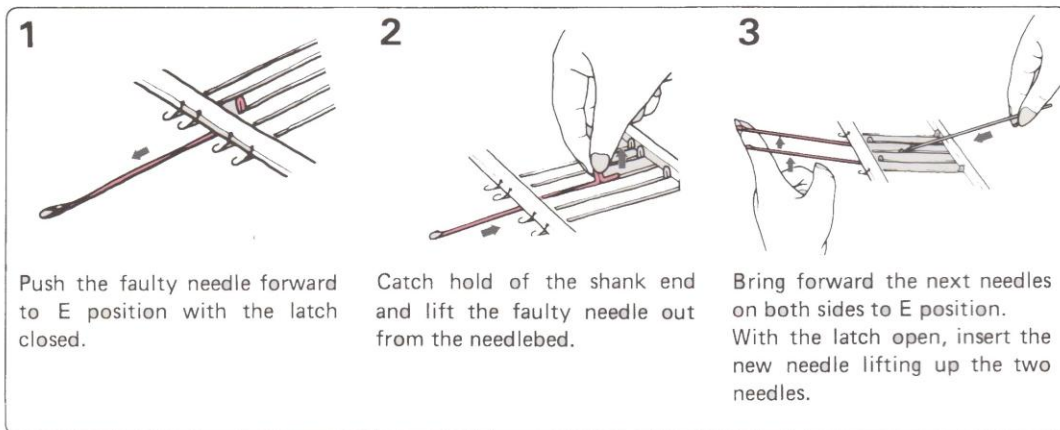

2 CLEANING AND MAINTENANCE

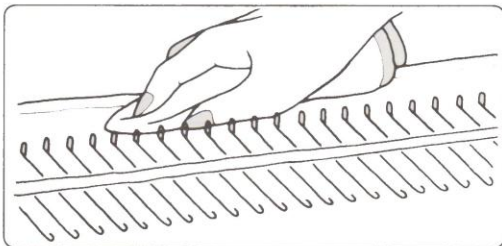

Clean plastic parts with a soft cloth and mild, neutral detergent.

* Do not use alcohol, benzine, thinners or petrol.

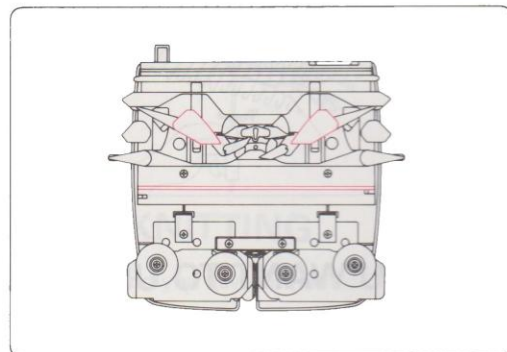

Lubricate the needlebed, rear and front rails, needle butt, and the areas indicated above using an oily cloth (silicone oil).

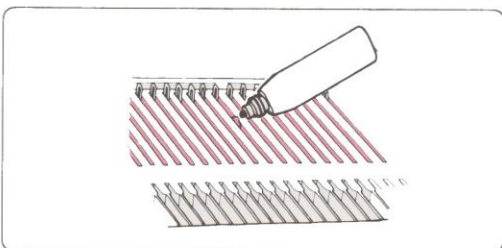

Should the Carriage feel heavy to operate, you should lubricate needlebed (especially into the slit) and wipe off the excessive oil. (You cannot use the oil except silicone oil). If you regularly clean and lightly oil your machine, it will make knitting easier and help to prevent excessive wear.

* When you come to use your machine again after you have stored it for a while, knit 20 – 30 rows with waste yarn to clean away any dirty oil.

HOW TO REPLACE THE KNITTING MACHINE

