

# knitking

*magazine*





dk 700

dk 697





dk 693

dk 692

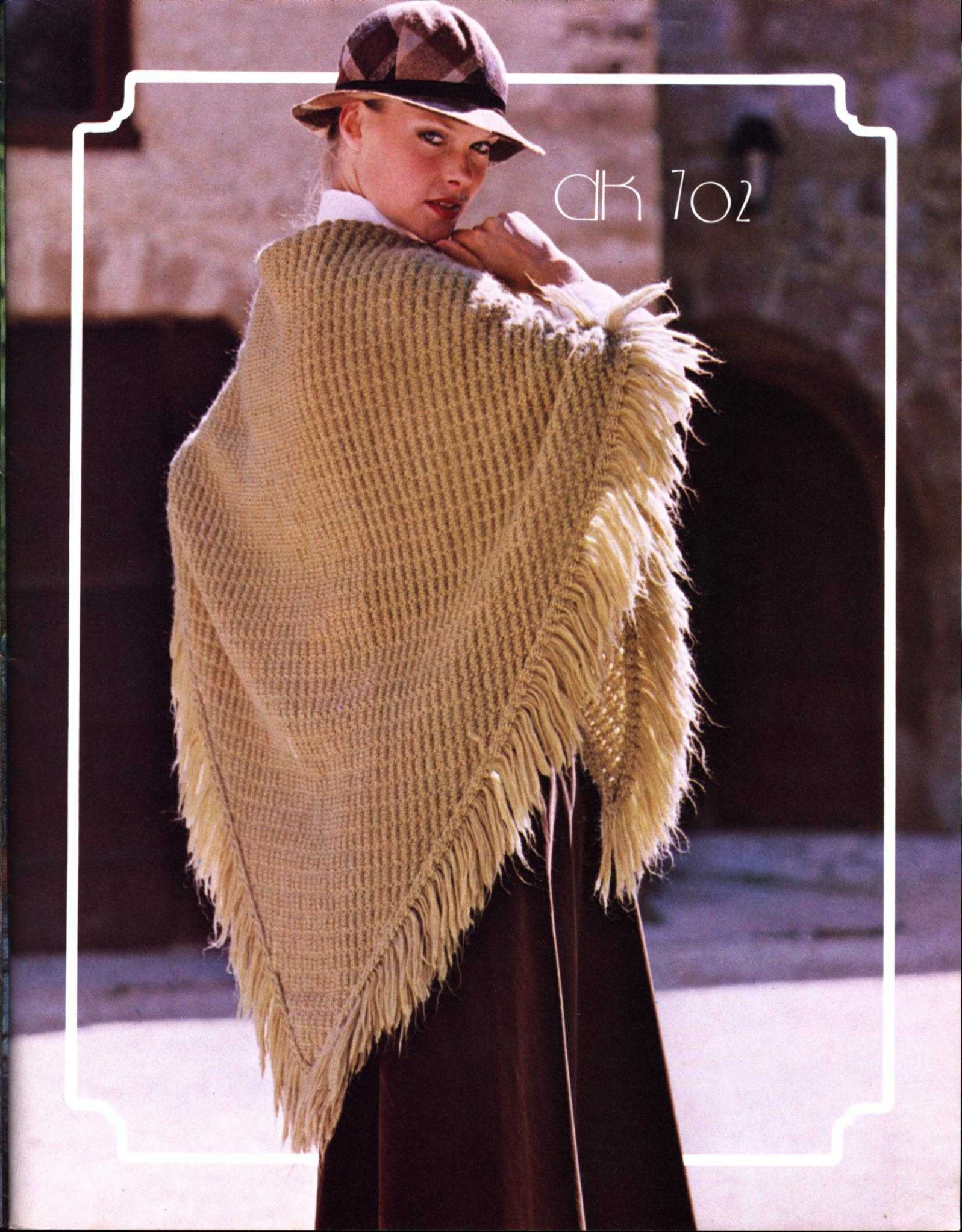

dk 702



ck 704

A woman with blonde hair, wearing a houndstooth beret and a cardigan with vertical stripes in grey, white, and dark blue, is smiling and feeding a brown goat. The goat is wearing a red collar with a reflective strip. The background shows a stone building with a window featuring a red and white striped pattern. The entire scene is framed by a white, hand-drawn style border.

dk 694



dk 701



dk 695



DK 696



# knitking

*magazine*

## editorial

TABLE OF CONTENTS

PAGE NO.

HP 692	Man's Jacket . . . . .	14
DK 693	Woman's Suit . . . . .	15
DK 694	Woman's Suit . . . . .	16
DK 695	Woman's Jacket . . . . .	18
DK 696	Woman's Pullover . . . . .	18
DK 697	Woman's 3-Piece Suit . . . . .	19
DK 698	Woman's Dress . . . . .	21
HP 699	Man's Jacket . . . . .	22
DK 700	Woman's Skirt & Jacket . . . . .	23
DK 701	Woman's Jacket . . . . .	24
DK 702	Woman's Triangle Shawl . . . . .	25
DK 703	Woman's Pullover & Skirt . . . . .	26
DK 704	Woman's Pullover . . . . .	26
HP 705	Man's Jacket . . . . .	27
KK 706	Child's Jacket . . . . .	28
KK 707	Girl's Dress . . . . .	29
KK 708	Boy's Jacket . . . . .	30
KK 709	Girl's Pullover & Pants . . . . .	32
KK 710	Child's Pullover . . . . .	33
KK 711	Boy's Pullover . . . . .	33
KK 712	Baby Sack & Jacket . . . . .	34
KK 713	Baby Sack & Pullover . . . . .	36
KK 714	Baby Overalls & Pullover . . . . .	35
KK 715	Child's Jacket & Pants . . . . .	36
KK 716	Girl's Jacket & Pants . . . . .	38
KK 717	Boy's Pullover . . . . .	38

KNITKING, as all our customers know, has for the past two years been fighting the inflationary spiral as it relates to knitting machines, yarns and all other merchandise distributed by us... We have to make a profit in order to stay in business and we have to pass factory price increases on to dealers and to consumers, but we do not go along with the belief that a certain fixed percentage of profit should be made from every sale irrespective of the size of the order.

Inflation seems to be a world wide problem... every day we read and hear about industrial strikes, shipping strikes, truck strikes, etc... We are all aware of continuing increases in the prices of housing, food, clothing, furniture, gasoline, transportation, in fact everything we need for day to day living... There is just no way to avoid the inflationary spiral... As prices increase, demands for increased wages are inevitable and higher wages result in higher prices for goods and services.

Inevitably prices of knitting machines, accessories and yarns are suffering the same at the factory increases as other goods and just as inevitably the consumer is asked to not only suffer the importer and distributor prices, but additional profit margins as well.

KNITKING therefore offers its products and services to dealers and consumers at substantially lower prices than its competitors and as a result, every KNITKING customer, whether retail store or consumer, obtains top quality merchandise at fair prices and our efforts at fighting the inflationary spiral in the knitting machine business are realized.

















When you buy KNITKING, you in fact can expect to pay lower prices than from any other source in the U.S., and indeed, lower prices than in most other countries of the world, even including many low income, so called poor countries... For example the worlds biggest selling and most popular knitting machine the KH 830 sells (just the machine without accessories) in Mexico City for the equivalent of approximately one thousand U.S. dollars... Similar prices apply in most South American countries... In many European countries, the KH 830 sells for hundreds of dollars more than KNITKING'S price... Some KNITKING products such as BELLINKY Seaming machines, GENIE knitting machines and many accessories are offered in the U.S. at prices comparable to those in their country of origin.









KNITKING customers also have a wealth of extra services available to them including beautiful KNITKING MAGAZINE, internationally recognized as the finest English language knitting machine publication in the world... Watch out for the next issue... it's going to be another very popular edition filled with gorgeous knit clothes.

Publisher: KNITKING CORPORATION, 1128 Crenshaw Blvd., Los Angeles, Calif. 90019. Telephone: (213) 938-2079. Published bi-monthly. Subscriptions: USA — \$15.00 annually, single copies \$4.00; Canada — \$18.00; other parts of the world — \$20.00. The entire contents of KNITKING MAGAZINE are copyright and must not be reproduced in any shape or form without the express permission, in writing of the publisher. © COPYRIGHT 1979 by KNITKING CORPORATION.

# Pattern Symbols





## Knitting – Chart Symbols

- ( ) Size Symbols (2nd Size)  
 < > 3rd Size  
 ① Color Number  
 Cast on  
 Stitch  
 Row  
 Hem  
 Bind off  
 Stockinette stitch – worn on the Knit side.  
 Stockinette stitch – worn on the Purl side.  
 Knit 1, Purl 1 Ribbing  
 Ribbing Pattern – worn on the Knit side.  
 Ribbing Pattern – worn on the Purl side.  
 Closed Dart  
 Open Dart  
 Put on a stitch holder  
 Reverse 1 section  
 On every other needle  
 Number of Rows between Shapings. Make increase (or decrease) FIRST, then knit 4 rows. For example: 3 x 1  means decrease (or increase) 1 st., knit 4 rows; decrease 1 st., knit 4 rows; decrease 1 st., knit 4 rows; decrease 1 st., knit 4 rows. All decreasing (or increasing) without row numbers as shown must be shaped on every 2nd row.









-  Increase  
 Increase 2 sts. With a transfer tool, move the sts. over the left (or right) leaving 2 empty needles at the point of increase. At the increase point, move 1 st. to the left, (or right) so that there is an empty needles on each side of a stitch. On each side of the center stitch, pick up a stitch from the row below and hang it onto the empty needle.  
 3 stitches on 1 needle. The 1st and 3rd stitch in a group of 3 has been hung on the 2nd or center needle.  
 Short Row increase or decrease; for instance on a flared skirt knitted sideways.  
 Pattern Stitch  
 Pattern Stitch – worn on the Knit side.  
 Pattern Stitch – worn on the Purl side.  
 Repeat

- I = Front  
 II = Back  
 III = Sleeve  
 IV = Skirt Front  
 V = Skirt Back  
 VI = Collar  
 VII = Pocket  
 VIII = Band  
 IX = Belt  
 X = Cuff  
 XI = Pants Front  
 XII = Pants Back

## Finishing – Chart Symbols

-  Match numbers on section for assembling.  
 Ease  
 Fold Line  
 Turn to the wrong side and hem.

## Stitch Symbols

-  Needles in holding position  
 Needles back into working position.  
 Empty needle (leave in working position)  
 Needle not used (in the out of work position).  
 Two stitches on 1 needle, either transferred from the right side or the left side, then put into holding position.  
 Needle holding 2 stitches. Stitch has been transferred from the RIGHT.  
 Needle holding 2 stitches. Stitch has been transferred from the LEFT.  
 Center of garment section



# General Instructions

## HOW TO READ THE CHARTS AND INSTRUCTIONS

There are 3 sizes given for each Pattern in KNITKING MAGAZINE. Above each Chart for the different sizes, you will see that the first and smaller sizes might be shown as 8/10, the second size as (12/14) and the third as [16/18]. Check the measurements at the bustline and hips on the Charts to be certain that you will knit the correct size, remembering these are ACTUAL measurements of the completed section and that there must be a bigger allowance at the bustline and hipline for a Jacket or a Coat than there would be for a fitted dress or a fitted blouse or pullover. The question in your mind should be "How do I want this garment to fit...?"

When you have chosen the size you need, you can follow the Charts as shown. You will notice that where the shapings are the same FOR ALL SIZES, only 1 set of shapings will be shown on the first Chart and if you are knitting the 2nd or 3rd size, you simply follow the shapings as given for the first size. If the shapings are different, this will be shown on the Charts and you should follow them as given.

On the Charts, increases and decreases will be shown as follows

5x1

**6** The number in the box means number of ROWS between the shapings, while the 5x1 above the box means - 1 st. 5x... so you will increase or decrease 1 st. every 6th row 5x.

ARMHOLE SHAPINGS - NECK SHAPINGS - SHOULDER SHAPINGS - are made on every 2nd row UNLESS there is a number in a box along side or below the shapings. The rule is... where there is no box with a number, the shaping is made on every 2nd row.

## THE PRINTED INSTRUCTIONS

You can follow the printed instructions or use them in combination with the Charts. Where there is any question in the printed instructions, you have the Charts to show you how the section will look.

The 3 sizes, with the different amounts of cast on stitches and the different shapings will look like this...

Cast on 124 (136) [148] sts. You will

Cast on 124 sts. for the first size.

Cast on 136 sts. for the 2nd size.

Cast on 148 sts. for the 3rd size.

The important thing to remember is that you MUST READ AHEAD so that you KNOW what to do for the size you are knitting. Sometimes where the number of stitches are the same but the number of times different, you will find shapings like this... 3 sts. 1x (2x) [3x], 2 sts. 1x (2x) [3x], 1 st. 3x (4x) [5x]. As you see, you MUST read ahead in order to follow the instructions as given for YOUR SIZE. The rows will be different for the different sizes in some cases... Shoulder and Neck shapings usually are worked at the SAME TIME for the back section - so watch for the words AT THE SAME TIME.

## HOLDING STITCHES ON THE LEFT SIDE WHILE SHAPING THE RIGHT SIDE

When knitting a section of garment in stockinette stitch, it is easy to hold the stitches on the left side while knitting the right half, but when knitting a Pattern Stitch such as a Norwegian Design, a Holding Position Design, Weaving, etc., you should use the following method. For the NECK SHAPING, we tell you to bind off the center sts., put the needles on the left into holding position and complete the right half first... so with a strand of contrast yarn, knit ALL of the left side stitches manually by hand, pulling each stitch back against the needle bed to the OUT OF WORK position. When the right side is completed, carefully pull the stitches held on contrast, forward into working position and as you do so, undo the contrast yarn, line up the needles (KNITKING AM 3 machine owners, put the stitches under the sinkers) and complete the left half.

If you own a Japanese machine, you may find that when knitting the right half with the left side held in this way, the sinker plate will mark the left side while you are knitting the right half. To prevent this marking, you can tape a piece of paper over the knitting, underneath the sinkers, or if you own a Reversing Bar, you can hang this onto the Sinkers while you are knitting the right half. When hanging the Reversing Bar, be sure the eyes of the bar go BETWEEN the Sinker Posts on the upper part of the bar so that the tips of the bar only - show above the needle bed.

## FULL FASHION DECREASING OR INCREASING

For Stockinette stitch, always use the Full Fashion method for increasing or decreasing.

**TO DECREASE:** Hang the 3rd stitch onto the 2nd stitch then move the stitches in to fill the empty needle.

**TO INCREASE:** Move the 2 end stitches 1 needle outward, then pick up the 3rd stitch from the row below and hang it onto the empty needle.

**FINISHING:** Block all sections. For PULLOVERS, JACKETS, and DRESSES: Join front to back at sides and shoulders. Sew sleeves together and set in. Hem lower edge and sleeve edges if needed. For a double neckband or armhole band, sew 1 edge to the inside and 1 to the outside of neck or armhole. For a single ribbed band, sew 1 edge to the outside of neck or armhole edge. For a cardigan or jacket with buttonholes, finish buttonholes and sew on buttons.

**PANTS:** Join front to back at sides. Sew inside leg seams, then join center front and back. Make hem at waistline and insert elastic. Hem lower edge of pants legs.

## THE SAMPLE SWATCH

Before you begin to knit any garment, you will need to knit a sample piece using the yarn you have chosen for your garment, so that you can check the stitch and row gauge which must measure the correct number of stitches and rows in 5 cm (2 inches).

For each Pattern in KNITKING MAGAZINE, we give you 3 tension numbers to work from and if you use the specified yarn for the garment, you should be able to get the correct stitch and row gauge using one of these numbers. Here is a very easy way to make your sample swatch and count the stitches and rows without actually counting, by using our KNITKING Converta Tape.

Supposing the Tension Numbers for the Stitch and Row Gauge are given as 5 to 7. Set the Tension Dial to the first number which is 5. With contrast waste yarn, and using the quick cast on method, cast on 60 stitches and knit 10 rows. Change to garment yarn and turn the Row Counter to 0. Knit 30 rows. Counting from each end, knit the 10th stitch on each side by hand with a small piece of contrast yarn. Leave the needles in working position and knit 30 rows (Row 60), then knit 4 rows with contrast waste yarn. Turn the Row Counter to 0 and the Tension Dial to 6 and with garment yarn, knit 30 rows. Mark the 10th stitch on each side as you did before, knit 30 rows, then 4 rows with contrast waste yarn. Turn the Row Counter to 0 and with Tension 7, repeat the above once more, ending with 10 rows of contrast waste yarn. Remove the work from the machine by passing the Slide across the needles without yarn (sometimes called 'dropping').

Pull and stretch the sample piece both lengthwise and diagonally from corner to corner, then lengthwise again. Do not count the stitches and rows immediately, but allow the sample to rest for several hours or even over night. This will allow the stitches and rows to return to their basic form.

When your sample has rested and you are ready to count the stitches and rows, the KNITKING CONVERTA TAPE will do the counting for you without any counting on your part. Use the Tape as follows:

Measure the stitches with the TAPE, BETWEEN the 40 stitches marked with contrast waste yarn. Push the SLIDE so that the LEFT EDGE lines up to this exact measurement. Now look down along side the SLIDE and find the number 40 on the TAPE. The number directly opposite on the SLIDE will be your Stitch Gauge to 5 cm (2"). To find the number of rows in 5 cm (2"), place the TAPE to measure over the 60 rows, push the SLIDE to this number with the left edge lined up, the look for the number 60 on the TAPE and directly opposite this will be the number of rows to 5 cm (2")

If you do not own a KNITKING CONVERTA TAPE, you must mark a 5 cm (2 inch) square in the center of the knitting, then count the number of stitches and rows within the square.

# hp 692

## MAN'S JACKET

SIZES: 36 (38) [40]

YARN: Crocus Crepe

GRAMS: color 1 700 700 750

color 2 300 300 350

TENSION: 8 to 10

GAUGE: 12 sts. 15 rows = 5 cm (2")

in Pattern.

Double Yarn is used for this Weaving Pattern. 830/820 machine owners, use Card No. 1 in your original set. Use single strand of yarn for the knitting. Work the Cable for Sleeve over 6 needles. Knit 8 rows, then cross 3 sts. over 3 sts. Drop 1 st. each side of Cable and latch the sts. up into a knit stitch.

FINISHING: See General Instructions. Work 1 row single crochet around collar and front edges, then put in zipper. (Use color 1).

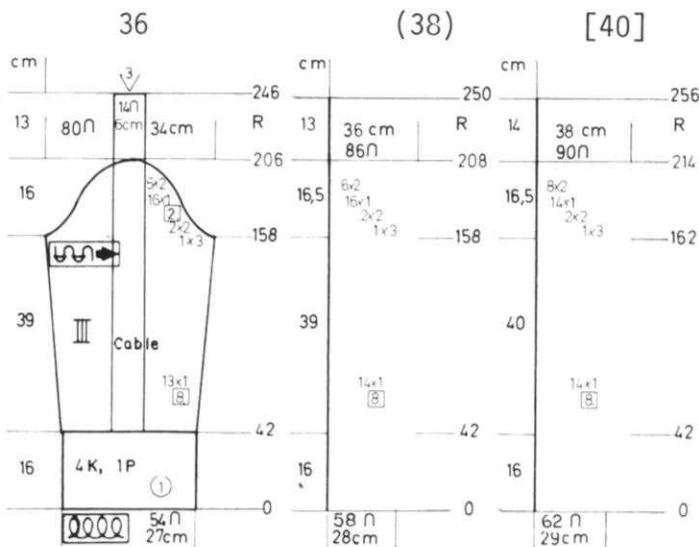

SLEEVES: III

Cast on 54 (58) [62] sts. with color 1 and work 42 rows K4, P1 Ribbing (or K1, P1). Continue in Stockinette stitch with CABLE DESIGN over the center 6 sts. Knit 8 rows, then cross 3 sts. over 3 sts. From time to time, drop the st. ON EACH SIDE of the cables and latch them up into knit stitches. ON EACH SIDE, increase 1 st. every 8th row 13x (14x) [14x]. After Row 158 (158) [162], SHAPE CAP: ON EACH SIDE, bind off 3 sts. 1x, 2 sts. 2x, 1 st. 16x, 2 sts. 5x. (3 sts. 1x, 2 sts. 2x, 1 st. 16x, 2 sts. 6x). [3 sts. 1x, 2 sts. 2x, 1 st. 14x, 2 sts. 8x].

After Row 206 (208) [214], continue with the CABLE over the remaining sts. to Row 246 (250) [256].

### PUNCH CARD ON PAGE 40

BACK: II

Cast on 124 (130) [136] sts. with color 1 and work 12 rows Stockinette stitch. Continue in Weaving Pattern using double yarn for the weaving.

Knit to Row 124 (130) [134].

SHAPE ARMHOLE: ON EACH SIDE, bind off

3 sts. 2x, 2 sts. 3x, 1 st. 2x.

(3 sts. 2x, 2 sts. 3x, 1 st. 2x).

[3 sts. 2x, 2 sts. 3x, 1 st. 3x].

Knit to Row 196 (204) [208].

SHAPE SHOULDER: ON EACH SIDE, bind off

6 sts. 4x, 5 sts. 1x.

(6 sts. 4x, 7 sts. 1x).

[7 sts. 4x, 5 sts. 1x].

After Row 208 (216) [220], bind off

the remaining sts.



COLLAR:

Cast on 148 (148) [152] sts. with color 1 and work in Ribbing. ON EACH SIDE, bind off 2 sts. every 4th row 5x. After Row 86, bind off.

FRONT: I Make 1, reverse 1.

Cast on 47 (52) [56] sts. with color 1 and work 12 rows Stockinette stitch. ON THE RIGHT (left for 2nd section), cast on 44 sts. for all sizes then continue in Pattern.

Knit to Row 123 (129) [133].

SHAPE ARMHOLE: Bind off

4 sts. 1x, 3 sts. 1x, 2 sts. 2x,

1 st. 4x.

(4 sts. 1x, 3 sts. 1x, 2 sts. 3x,

1 st. 4x).

[4 sts. 1x, 3 sts. 1x, 2 sts. 3x,

1 st. 4x].

ON ARM EDGE, increase 1 st.

every 8th row 3x.

After Row 174 (182) [186], put

52 (55) [58] sts. on the

left into holding position and complete the right side first.

\*ON NECK SIDE, bind off

5 sts. 1x, 4 sts. 1x, 3 sts. 2x,

2 sts. 2x, 1 st. 4x.

(6 sts. 1x, 4 sts. 1x, 3 sts. 2x,

2 sts. 2x, 1 st. 4x).

[6 sts. 1x, 4 sts. 1x, 3 sts. 2x,

2 sts. 2x, 1 st. 5x].

After Row 208 (216) [220], bind

off the remaining sts.

Bring the needles on the left into

working position and knit 1 row

in Pattern to the left side, turn

the Row Counter back to 174 (182)

[186] and work the left half.

Follow the neck shaping as given

from \* and AT THE SAME TIME

after Row 195 (203) [207], SHAPE

SHOULDER: Bind off

6 sts. 4x, 5 sts. 1x.

(6 sts. 4x, 7 sts. 1x).

[7 sts. 4x, 5 sts. 1x].



FLAP for simulated pocket. Make 2.

Cast on 32 sts. and work in weaving pattern. After Row 12, ON EACH SIDE, bind off 5 sts. 3x. Bind off the remaining 2 sts.

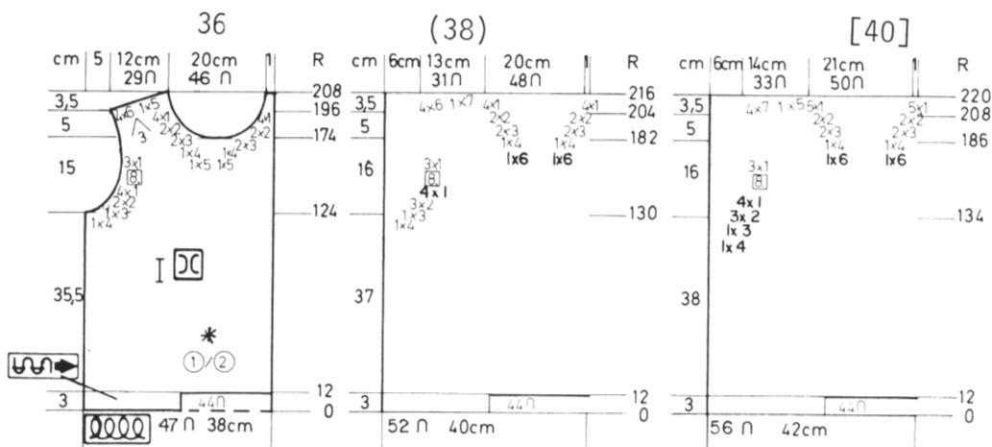
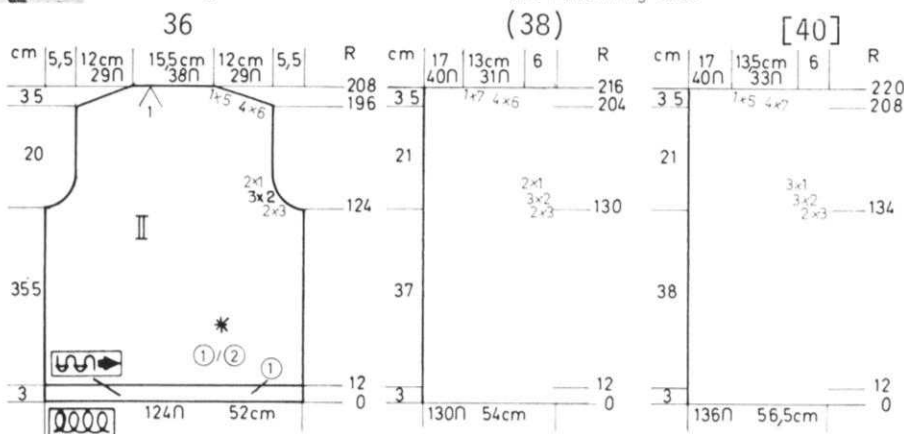
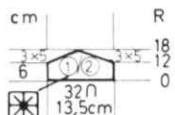

# dk 693

## WOMAN'S SUIT

SIZES: 8 (10) [12]

YARN: Crocus Crepe

GRAMS:  
color 1 700 750 800  
color 2 500 550 600

TENSION: 8 to 10

GAUGE: 12 sts. 16 rows = 5 cm (2")

Double Yarn is used for this Weaving Pattern. 830/820 machine owners, use Card No. 1 in your original set. Use single strand of yarn for the knitting. The Cable strips for sleeves are knitted separately, then sewn in place.

FINISHING: See General Instructions.  
JACKET: Sew braid trim on sleeves. Work 2 rows single crochet around edges. Sew collar together and sew in place (see picture). On each side of front, sew on 4 buttons spaced approximately 5 cm (2") apart.  
SKIRT: Make pleat over the center front of skirt and sew in place. With pur1 side facing you, hang 34 sts. of the pocket onto machine and with color 1, work 14 rows stockinette stitch AND AT THE SAME TIME, ON EVERY 2nd ROW, decrease 1 st. on inside edge and increase 1 st. on outside edge. After Row 14, bind off. Sew 2 darts on the skirt back. Finish waistline of skirt with 2 rows single crochet then sew on an elastic band and turn to the wrong side - or you can leave the left side open and sew belting to the inside then close with hooks and eyes.



### SKIRT FRONT:

Make 2 Pocket Linings first. Cast on 28 sts. with color 1. Work 20 rows Stockinette stitch. Work 42 rows in Pattern. Remove the sts. onto contrast waste yarn.

For Skirt, cast on 192 (198) [198] sts. with color 1 and work 16 rows Stockinette stitch. Continue in Pattern.

After Row 36, ON EACH SIDE, decrease 1 st. every 12th row 16x. (every 14th row 15x). [every 15th row 14x]. AND AT THE SAME TIME, after Row 168, remove the center 58 sts. onto waste yarn (or you can bind off if you prefer). Move the remaining sts. together and continue in pattern. Continue the side decreases.

After Row 190, ON EACH SIDE, bind off 1 st. 4x, then 2 sts. 12x for all sizes. Hang the POCKET LINING STS. onto the 28 needles ON EACH SIDE that you just bound off and continue in Pattern.

After Row 244, bind off the remaining stitches. See FINISHING for pocket bands.

### PUNCH CARD ON PAGE 40

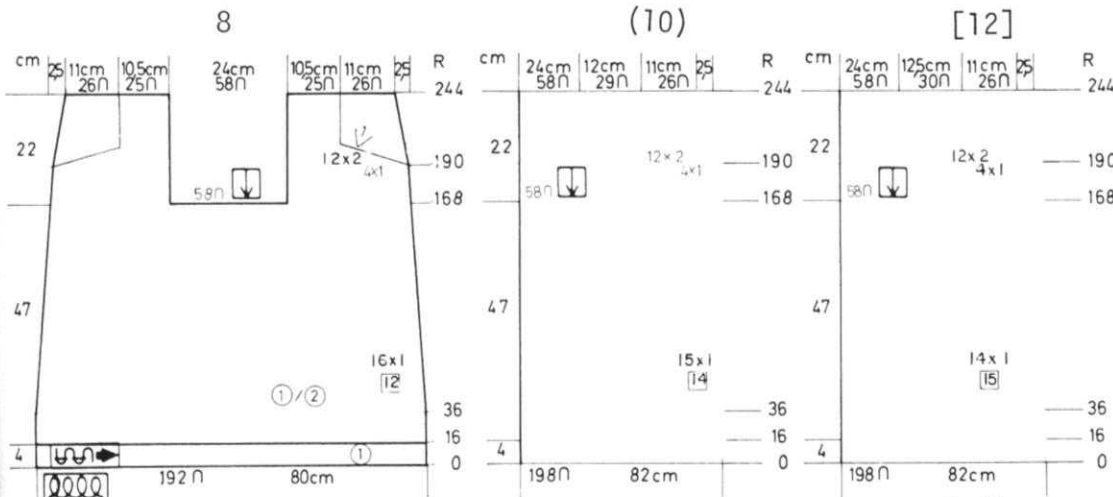

### SKIRT BACK:

Cast on 150 (156) [162] sts. with color 1 and work 16 rows Stockinette stitch. Continue in Pattern using double yarn for the weaving. ON EACH SIDE, after Row 36, decrease 1 st. every 10th row 12x (12x) [13x]. After Row 160, ON EACH SIDE, decrease 1 st. every 6th row 13x. (every 4th row 5x, every 6th row 10x). [every 4th row 5x, every 6th row 10x]. After Row 244, bind off the remaining stitches.

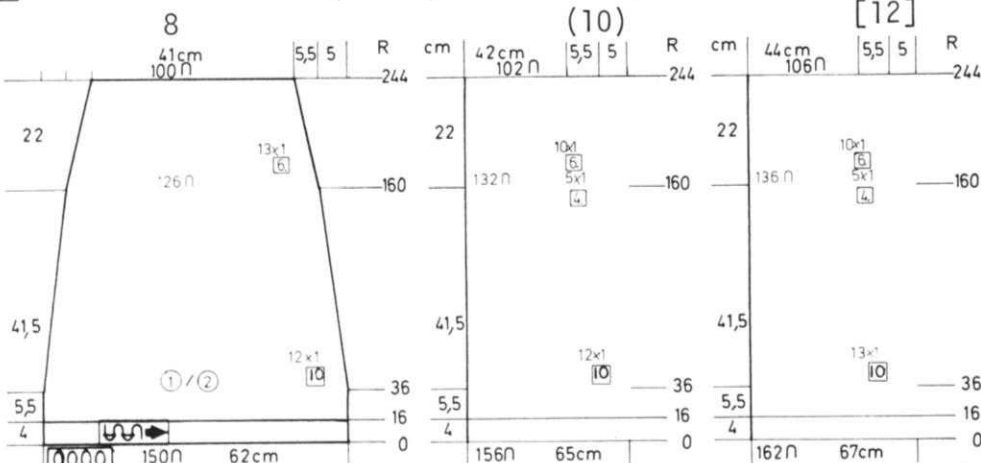

### JACKET BACK:



Cast on 108 (112) [118] sts. with color 1 and work in Pattern. ON EACH SIDE, decrease 1 st. every 6th row 2x. After Row 30, ON EACH SIDE, increase 1 st. every 10th row 2x (4x) [4x]. After Row 78 (78) [82], SHAPE ARMHOLE: ON EACH SIDE, bind off 3 sts. 1x, 2 sts. 2x, 1 st. 3x. (3 sts. 1x, 2 sts. 2x, 1 st. 3x). [3 sts. 1x, 2 sts. 2x, 1 st. 4x]. After Row 134 (134) [138], SHAPE SHOULDER: ON EACH SIDE, bind off 5 sts. 4x, 6 sts. 1x. (7 sts. 4x). [6 sts. 5x]. After Row 144 (144) [148], bind off the remaining sts.

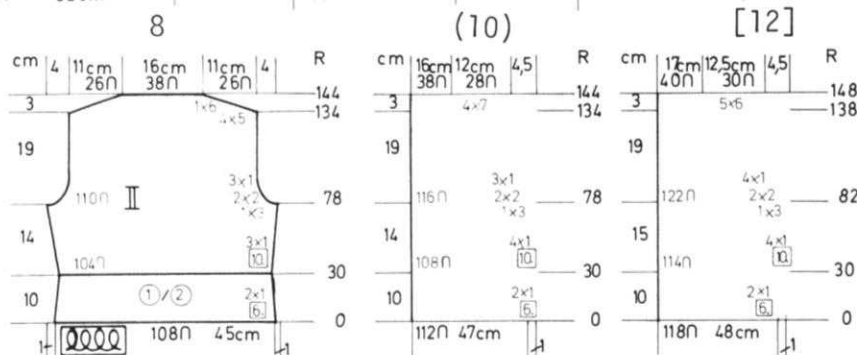

# dk 693

JACKET FRONT: Make 1, reverse 1.

Cast on 1 st. and work in Pattern. SHAPE BOTH SIDES AT THE SAME TIME. ON THE RIGHT (left for 2nd section) cast on 1 st. 6x (7x) [7x] more then cast on 2 sts. 5x for all sizes - AT THE SAME TIME ON THE LEFT, cast on 2 sts. 12x (12x) [13x] then cast on 14 (18) [20] sts. After Row 24, ON SIDE EDGE, decrease 1 st. every 6th row 2x. After Row 54 (58) [58], ON SIDE EDGE, increase 1 st. every 10th row 3x. After Row 96 (102) [106], SHAPE FRONT EDGE and WATCH FOR ARMHOLE SHAPING. FOR FRONT EDGE, increase 1 st. every 2nd row 2x, every 4th row 14x for all sizes and AFTER ROW 101 (107) [111], SHAPE ARMHOLE: Bind off 3 sts. 1x, 2 sts. 2x, 1 st. 3x. (3 sts. 1x, 2 sts. 3x, 1 st. 4x). [3 sts. 1x, 2 sts. 3x, 1 st. 6x]. After Row 146 (154) [158], SHAPE NECK: Bind off (and watch for SHOULDER SHAPING) for neck - 2 sts. 2x, 6 sts. 1x, 4 sts. 2x, 3 sts. 2x, 2 sts. 3x, 1 st. 6x for all sizes. AT THE SAME TIME, after Row 157 (165) [169] SHAPE SHOULDER: Bind off 5 sts. 4x, 6 sts. 1x. (7 sts. 4x) [6 sts. 5x].

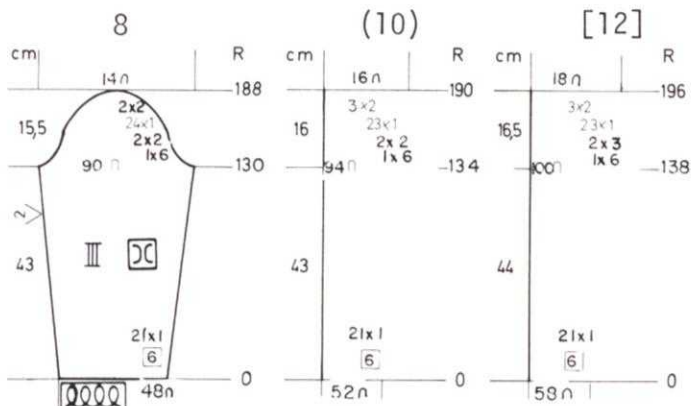
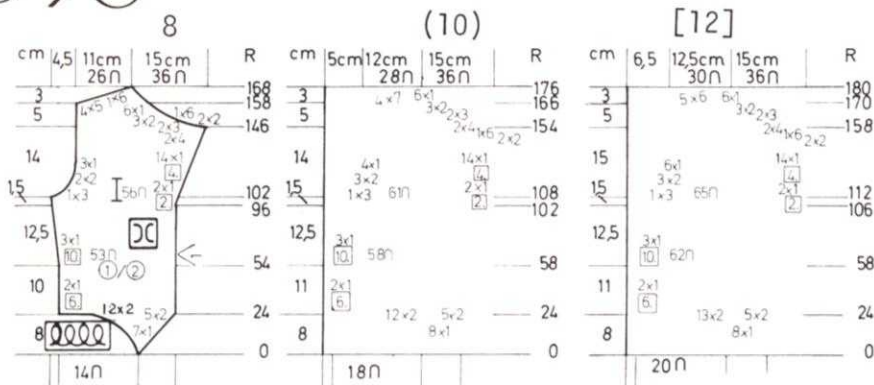

SLEEVES: III

Cast on 48 (52) [58] sts. with color 1 and work in Pattern. ON EACH SIDE, increase 1 st. every 6th row 21x for all sizes. After Row 130 (134) [138], SHAPE CAP: ON EACH SIDE, bind off 6 sts. 1x, 2 sts. 2x, 1 st. 24x, 2 sts. 2x. (6 sts. 1x, 2 sts. 2x, 1 st. 23x, 2 sts. 3x). [6 sts. 1x, 3 sts. 2x, 1 st. 23x, 2 sts. 3x]. After Row 188 (190) [196], bind off the remaining sts.

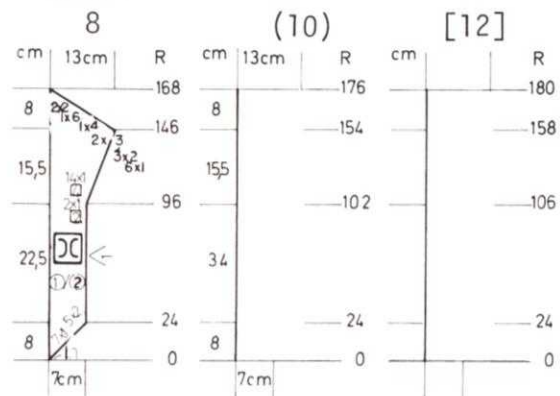

FRONT FACING: Make 1, reverse 1.

Cast on 1 st. with color 1 and work in Pattern. ON THE RIGHT (left for second section), increase 1 st. 6x more then cast on 2 sts. 5x. Knit to Row 96 (102) [106]. ON THE RIGHT (left), increase 1 st. every 2nd row 2x, then every 4th row 14x. After Row 146 (154) [158], bind off 2 sts. 2x, 6 sts. 1x, 4 sts. 1x, 3 sts. 2x, 2 sts. 3x, 1 st. 3x.

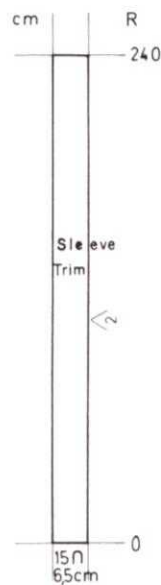

BRAID TRIM FOR SLEEVES. Make 2.

Cast on 15 sts. with 3 sts. on the main machine, 1 st. on Ribber, 6 sts. on main machine. 1 st. on Ribber, 3 sts. on main machine. \*Knit 8 rows, then cross the 6 center sts. 3 and 3 for a Cable. REPEAT from \* for approximately 240 rows. The trim must go down the center of sleeve and across the shoulder.

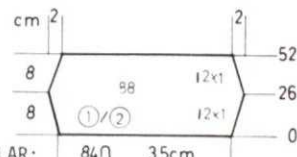

COLLAR: 84n 35cm

Cast on 84 sts. with color 1 and work in Pattern. ON EACH SIDE, increase 1 st. every 2nd row 12x. After Row 26, ON EACH SIDE, decrease 1 st. every 2nd row 12x. After Row 62, bind off.

# dk 694

WOMAN'S SUIT

SIZES: 8/10 (12) [14]

YARN: Crocus Crepe

GRAMS: color 2 450 500 550

color 2 800 850 900

TENSION: 7 to 9

GAUGE: 12 sts. 17 rows = 5 cm (2") (St).

12 sts. 40 rows = 5 cm (Pat).

The Skirt is Stockinette stitch and the front section is knitted in 3 pieces. The Jacket is a tuck stitch combined with Stockinette stitch and is knitted sideways on the machine. The Purll side is the right side. Bands and Collar are Stockinette stitch.



FINISHING: See General Instructions. SKIRT: Sew darts on front and back sections, using the marked stitches as guide. Turn under 4 cm for waistband then pull elastic through casing. Make hem at lower edge. JACKET: Turn over 4 cm on front edges and sew in place. Make hem at lower edge. Sew 1 edge of Collar to the inside and 1 to the outside of neckline.

PUNCH CARD ON PAGE 40

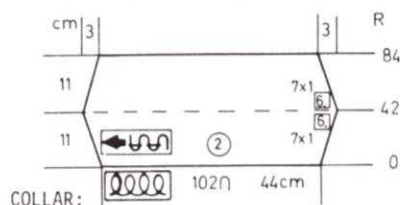

COLLAR: 102n 44cm

Cast on 102 sts. with color 2 and work Stockinette stitch. ON EACH SIDE, increase 1 st. every 6th row 7x. After Row 42, ON EACH SIDE, decrease 1 st. every 6th row 7x. After Row 84, bind off.



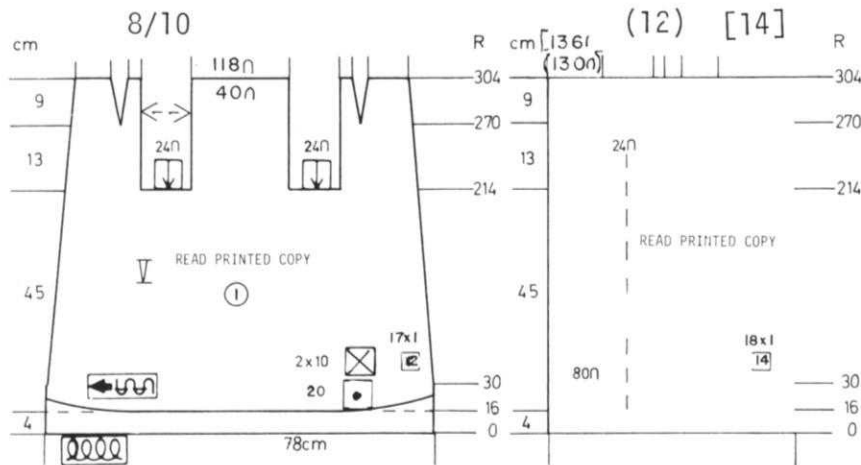

SKIRT FRONT: Made in 3 sections.

Make the side pieces first - reversing the sides for the shapings.

Cast on 56 (61) [63] sts. with color 1 and work Stockinette stitch.

Knit to Row 17. Put 20 sts. on the right (left for 2nd section) into holding position. (Short Rows). Knit 2 rows, then bring back into working position 10 sts. 2x.

Knit to Row 30. ON SIDE EDGE (Right, then left for 2nd section), decrease 1 st. every 12th row 17x. (every 14th row 18x). [every 14th row 18x].

After Row 214, remove the sts. onto contrast waste yarn.

Make a second side section with the shapings on the left side.

CENTER FRONT: Cast on 88 (92) [94] sts. with color 2 and work Stockinette stitch.

Knit to Row 214. ON EACH SIDE, bind off (or remove onto waste yarn). 24 sts. ON EACH SIDE of the remaining sts. hang the side sections back onto the machine. Be sure Row Counter is at 214.

Continue working over all the sts. ON EACH SIDE, decrease 1 st. after Row 222 for the first size. For 2nd and 3rd sizes, decrease 1 st. ON EACH SIDE after Rows 226, 240, 254, 268.

After Row 270, ON EACH SIDE, mark needles 24 (26) [28] for guide to sewing in darts later. After Row 304, bind off the remaining stitches.

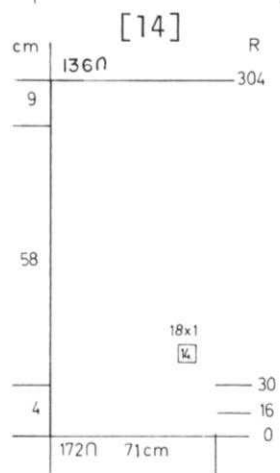
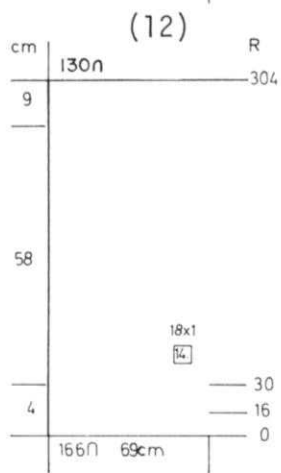
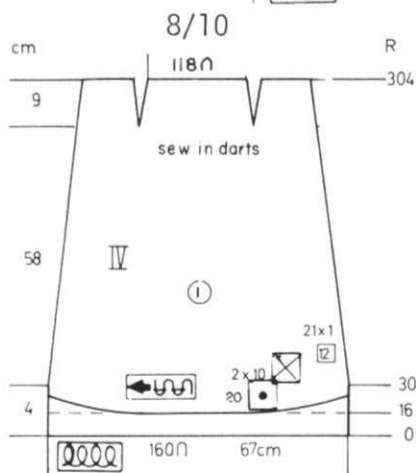

SKIRT BACK:

Cast on 160 (166) [172] sts. with color 1 and work Stockinette stitch. Knit to Row 16.

Work SHORT ROWS: ON OPPOSITE SIDE of Cam Box, put into holding position 20 sts. before knitting the next 2 rows. ON OPPOSITE SIDE OF CAM BOX, bring back into working position, 10 sts. 2x ON EACH SIDE.

Knit to Row 30. ON EACH SIDE, decrease 1 st. every 12th row 21x. (every 14th row 18x).

[every 14th row 18x]. After Row 270, ON EACH SIDE, mark needle 24 (26) [28] for guide to sewing in dart later.

After Row 304, bind off the remaining stitches.

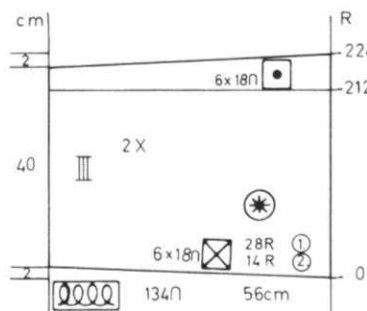

SLEEVES: Make 2.

Cast on 134 sts. with color 2 and work in Pattern. Put 108 sts. on the left into holding position then bring back 18 sts. 6x on every 2nd row.

Continue in Pattern to Row 212. ON THE LEFT, put 18 sts. 6x into holding position. After Row 224, bring all the needles back into working position, knit 1 row then bind off.

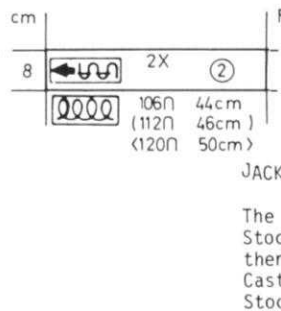

JACKET LOWER BAND: Make 2.

Cast on 106 (112) [120] sts. with color 2 and work Stockinette stitch to Row 32, then bind off.

JACKET:

The Jacket is a REPEAT of 14 rows Stockinette stitch with color 2 then 28 rows TUCK stitch with color 1. Cast on 134 sts. with color 2 and work Stockinette stitch.

After Row 8, MAKE BUTTONHOLES over needles as shown on the Chart. REPEAT the BUTTONHOLES after Row 22, then knit to Row 30.

ON THE LEFT, bind off 12 sts. Continue in Pattern, beginning with the 28 rows TUCK stitch.

ON THE RIGHT, for NECK, cast on 1 st. 4x, 2 sts. 3x, 3 sts. 1x, 4 sts. 1x.

(1 st. 4x, 2 sts. 4x, 3 sts. 1x, 4 sts. 1x).

[1 st. 5x, 2 sts. 4x, 3 sts. 1x, 5 sts. 1x].

After Row 50 (52) [54], SHAPE SHOULDER. ON EVERY 8th ROW, decrease 1 st. 8x. After Row 124 (128) [132], bind off 53 (55) [57] sts. then knit to ROW 174 (178) [184].

Cast on 53 (55) [57] sts. SHAPE SHOULDER. Increase 1 st. every 8th row 8x. Mark Row 248 (256) [266] for completion of shoulder.

Knit to Row 275 (285) [297]. This is the center back of jacket and you should mark this row. Work the 2nd half of jacket following the instructions in REVERSE. Omit the buttonholes when you reach the band.

8/10

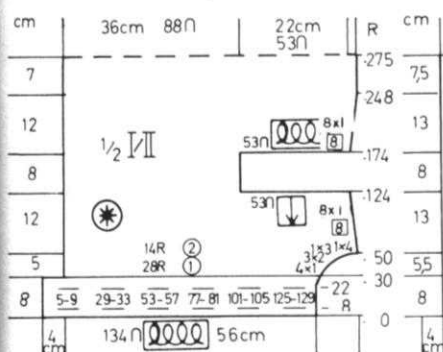

(12)

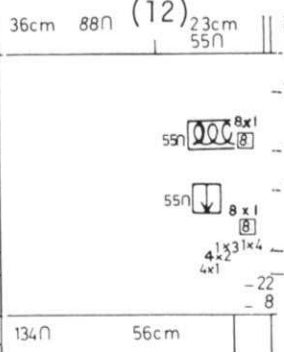

[14]

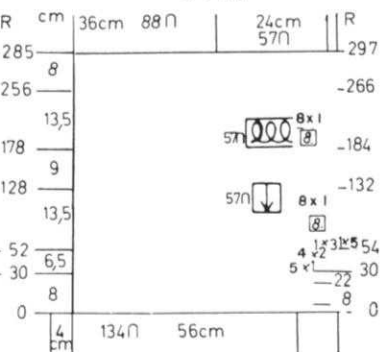

# dk 695

## WOMAN'S JACKET

SIZES: 8/10 (12) [14]  
 YARN: Color 1 = Fortissima  
 Colors 2, 3, 4 = Amore

GRAMS:  
 color 1 250 300 350  
 color 2 150 200 200  
 color 3 150 200 200  
 color 4 150 200 200

TENSION: 5 to 7  
 GAUGE: 13 1/2 sts. 15 rows = 5 cm (Pat).  
 16 sts. 19 rows = 5 cm (Rib).

### PUNCH CARD ON PAGE 40

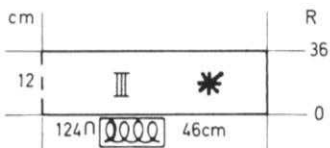
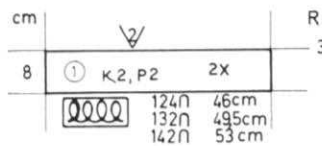
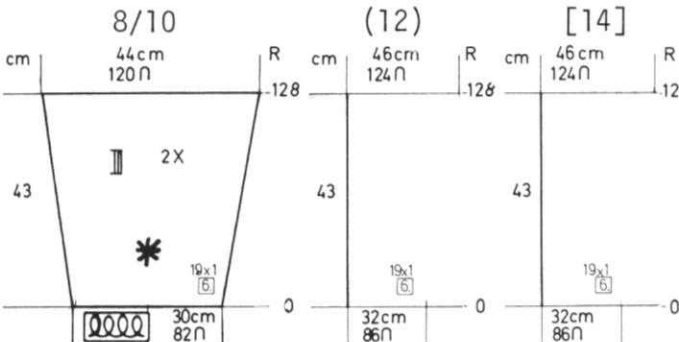
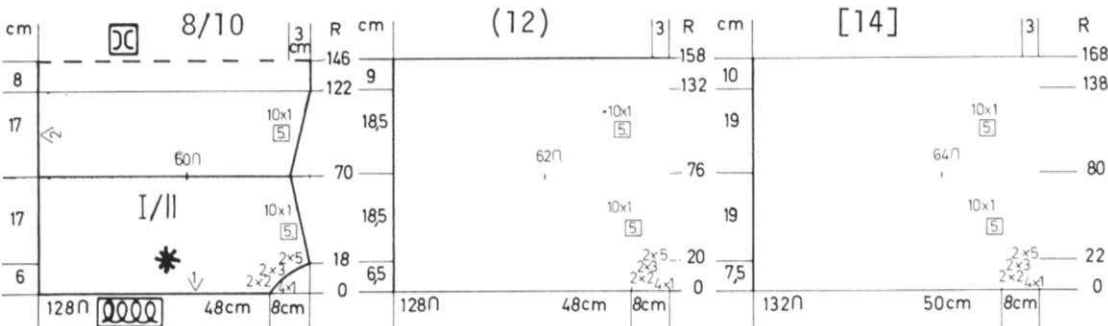

### COLLAR:

Bring 124 sts. into working position then set the needles with 3 in work and 3 out of work. Cast on. Knit in the Weaving Pattern to Row 36, then bind off.

### ARMBANDS: Make 2.

Cast on 120 (124) [128] sts. with color 1 and work 10 rows Stockinette stitch. Bind off.

### CUFFS: Make 2

Cast on 38 (42) [46] sts. with color 1 and work 32 rows K2, P2 Ribbing. Bind off.

The Jacket is knitted sideways on the machine in a Weaving Pattern. 830 machine owners use Card No. 1 of your original set of cards. Use Color 1 for the knitting, and weave with colors 2, 3, 4, held together. After Bringing the required number of needles into working position, you must set the needles with 3 needles in work, 3 needles out of work across the needle bed. The out of work needles ARE COUNTED in the instructions and remember to always count them as stitches when shaping the Jacket.

FINISHING: See General Instructions. Sew neckband to neckline. Sew Armbands to sleeve opening then sew in sleeves. Sew 1 edge of collar to the inside and 1 to the outside of neckband. Sew on waistbands and front bands. Finish buttonholes and sew on buttons.



### FRONT & BACK: 1/II

Bring 128 (128) [132] sts. into working position and set the needles with 3 needles in work and 3 needles out of work. Cast on, then work in Pattern holding the 3 strands of yarn TOGETHER for the weaving. ON THE RIGHT, on every 2nd row, cast on 1 st. 4x, 3 sts. 2x, 2 sts. 2x, 5 sts. 2x. After Row 18 (20) [22], SHAPE SHOULDER: Decrease 1 st. every 5th row 10x. After Row 70 (76) [80], with contrast waste yarn, knit 2 rows BY HAND over 60 (62) [64] sts. on the right (sleeve opening). REMEMBER to count the the empty needles as stitches. Continue in Pattern. SHAPE SHOULDER: increase 1 st. every 5th row 10x. After Row 122 (132) [138], mark edge stitch for end of shoulder then knit to Row 146 (158) [168]. This is HALF of Jacket and you must now work BACKWARDS to complete the 2nd half. When you are ready to bind off, bring up center needle of the out of work needles and knit 1 very loose row, then bind off.

### SLEEVES: Make 2.

Bring 82 (86) [86] needles into working position then set up the needles same as for the front and back of Jacket. Cast on. Continue in Pattern. ON EACH SIDE, increase 1 st. every 6th row 19x. After Row 128, bind off as you did for the Jacket.

### NECKBAND:

Cast on 100 sts. with color 1 and work 10 rows Stockinette stitch. Bind off.

### WAISTBAND: Make 2.

Cast on 124 (132) [142] sts. with color 1 and work K2, P2 Ribbing. After Row 30, bind off.

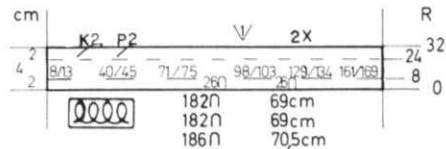

### FRONT BANDS Make 2.

Cast on 182 (182) [186] sts. with color 1 and work K2, P2 Ribbing. Make BUTTONHOLES after Row 8 and 24 over needles 8 to 13, 40 to 45, 71 to 75, 98 to 103, 129 to 134, 161 to 169. After Row 32, bind off. Work the 2nd band the same but OMIT the buttonholes.

# dk 696

## WOMAN'S PULLOVER

SIZES: 8/10 (12)  
 YARN: Color 1 = Crocus Crepe  
 Color 2 = Angora  
 plus few yards of different color yarns for flower and ball

Color 2, plus the various colors are not included in Kit.

GRAMS:  
 Color 1 700 750  
 2 - 10 gram balls of Angora  
 1 - ball mohair for ball

TENSION: 5 to 7  
 GAUGE: 14 sts. 23 rows = 5 cm (2")

Stockinette stitch with Motif on front section. Bands are K1, P1 Ribbing.

FINISHING: See General Instructions. Work the Design following the Line Drawing in duplicate stitch on the front section (see Picture). Fold over 1 cm at neckline and sew in place.



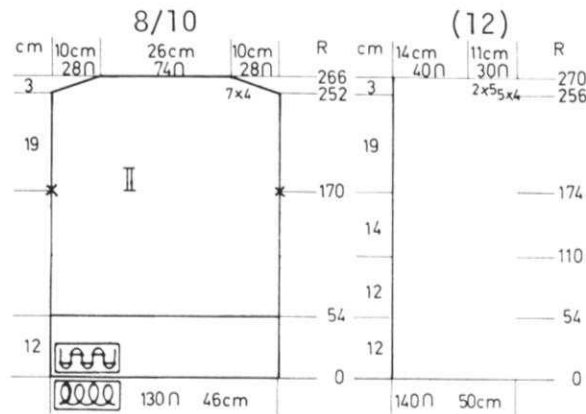

BACK: II

Cast on 130 (140) sts. with color 1 and work 54 rows K1, P1 Ribbing. Continue in Stockinette stitch. Knit to Row 170 (174). Mark each side with bit of contrast yarn for placement of sleeves, then knit to Row 252 (256).

SHAPE SHOULDER: ON EACH SIDE, bind off 4 sts. 7x (4 sts. 5x, 5 sts. 2x). After Row 266 (270), bind off the remaining sts.

FRONT: I

Work the front the same as the back to Row 252 (256). SHAPE NECK: Put half the sts. on the left into holding position and complete the right side first.

\*SHAPE SHOULDER AND NECK AT THE SAME TIME: For shoulder, make the bind offs the same as the back and ON NECK SIDE, bind off 15 sts. 1x, 5 sts. 1x, 4 sts. 3x, 2 sts. 2x, 1 st. 1x. (15 sts. 1x, 6 sts. 2x, 4 sts. 2x, 2 sts. 2x, 1 st. 1x). Bring the needles on the left into working position, knit 1 row to the left side, turn the Row Counter back to 252 (256) and complete the left half. Follow the instructions from \*.

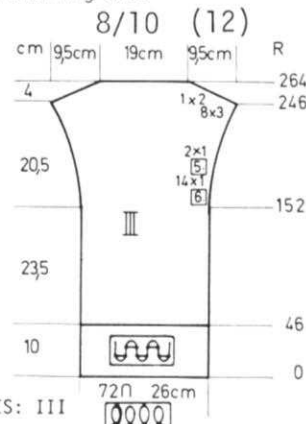
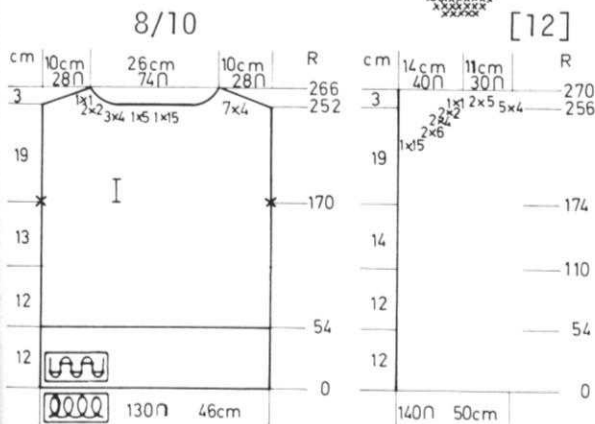

SLEEVES: III

Cast on 72 sts. with color 1 and work 46 rows K1, P1 Ribbing. Continue in Stockinette stitch. Knit to Row 152. ON EACH SIDE, increase 1 st. every 6th row 14x, every 5th row 2x. After Row 246, ON EACH SIDE, bind off 3 sts. 8x, 2 sts. 1x. After Row 264, bind off the remaining sts.

DK 697



PUNCH CARD ON PAGE 40

WOMAN'S 3-PIECE SUIT

SIZES: 8/10 (12) [14]

YARN: JACKET - 100% Wool - Appox. 2 lb cone & SKIRT: for all sizes plus 1 ball color 3 for bands.

PULLOVER: Vienna

GRAMS: color 1 250 250 300 color 2 250 250 300 color 3 300 300 350

TENSION: 6 to 8

GAUGE: Pat: 14 sts. 25 rows = 5 cm (2") Stock: 13 sts. 19 rows = 5 cm (2")

The Pattern stitch for the Jacket & Skirt is knitted on main machine plus the Ribber. Punch your own card. When making your swatch, count only the sts. from the main machine for your stitch gauge. The Pullover is stockinette stitch with color stripes.

FINISHING: See General Instructions. Skirt: You can make hem in lower edge of skirt or can knit an edging by casting on 10 sts. and work stockinette stitch for as long as you need. Sew 1 edge to inside and 1 to the outside. Jacket: Sew 1 edge of band to the inside and 1 to the outside of all edges. Make 4 cords using 4 sts. approximately 6 cm long. Sew in place on jacket for buttonholes then sew buttons to left side (see picture). Pullover: Sew on Collar with 88 sts. for the front neckline and the remainder for the back.

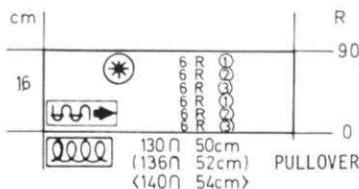

PULLOVER COLLAR

Cast on 130 (136) [140] sts. with color 3 and work Stockinette stitch with REPEATED color stripes as shown on the Chart. After Row 90, bind off.

JACKET FRONT AND NECKBAND.

Cast on 10 sts. with color 3 and work stockinette stitch for as long as you need to go around all edges. Make 2 more bands for the sleeve edges in the same way.





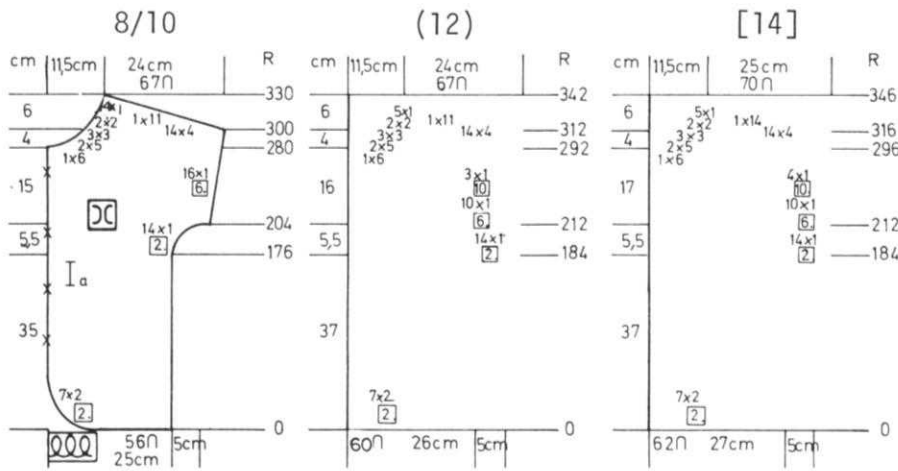

JACKET FRONT: Make 1, reverse 1.

Please remember that for all cast on's bind offs, and all shapings that you duplicate the same number of stitches for cast on's bind offs and shapings on the Ribber as you use for the Knitter.

Cast on 56 (60) [62] sts. with color 1 and work in Pattern.  
 ON THE LEFT (right for 2nd half) on every 2nd row, cast on 2 sts. 7x. Knit to Row 176 (184) [184]  
 ON SIDE EDGE, increase 1 st. every 2nd row 14x.  
 After Row 204 (212) [212], ON ARM SIDE, increase 1 st. every 6th row 16x.  
 (every 6th row 10x, every 10th row 3x).  
 [every 6th row 10x, every 10th row 4x].

AT THE SAME TIME, after Row 279 (291) [295] SHAPE NECK: Bind off 6 sts. 1x, 5 sts. 2x, 3 sts. 3x, 2 sts. 2x, 1 st. 4x.  
 (6 sts. 1x, 5 sts. 2x, 3 sts. 3x, 2 sts. 2x, 1 st. 5x).  
 [6 sts. 1x, 5 sts. 2x, 3 sts. 3x, 2 sts. 2x, 1 st. 5x].  
 After Row 300 (312) [316], SHAPE SHOULDER same as the back.

# dk 698

PUNCH CARD ON PAGE 40

## WOMAN'S DRESS

SIZES:	8/10	(12)	[14]
YARN:	Vienna		
GRAMS:			
color 1	600	600	650
color 2	150	150	200
color 3	50	50	50
color 4	50	50	50
color 5	50	50	50
color 6	50	50	50
TENSION: Stock	6 to 7		
Pat.	4 to 6		

A combination of Stockinette stitch and color stripes in a Tuck Stitch. 830 machine owners use Card No. 2. Other machine owners, punch your own card. Push in both Tuck Buttons. Collar and sleeve bands are K1, P1 Ribbing.

FINISHING: See General Instructions. The lower edge of skirt can be finished off by picking up the sts. around lower edge onto a round knitting needle then work 12 rows garter stitch - OR, you can slip stitch crochet 1 row into the open sts. then work a few rows of single crochet.



SKIRT SECTION: Make 2.

With contrast waste yarn, cast on 174 (184) [184] sts. and work 8 to 10 rows stockinette stitch. Change to color 1. Counter 0. Work in PATTERN with the color changes as shown on the Chart to Row 174 then continue with a REPEAT of 26 rows Stockinette stitch with color 1 and 8 rows Tuck Stitch with color 2...

AT THE SAME TIME, ON EACH SIDE, decrease 1 st. every 20th row 14x, every 10th row 6x.  
 (every 18th row 17x, every 10th row 6x).  
 [every 18th row 17x, every 10th row 6x].  
 After Row 326, ON EACH SIDE OF CENTER, mark the 24th (31st) 33rd st. for DART, then ON EVERY 12th row, decrease 2 sts. for DARTS ON EACH SIDE.  
 After Row 376, remove the remaining sts. onto contrast waste yarn. Make another skirt section the same.

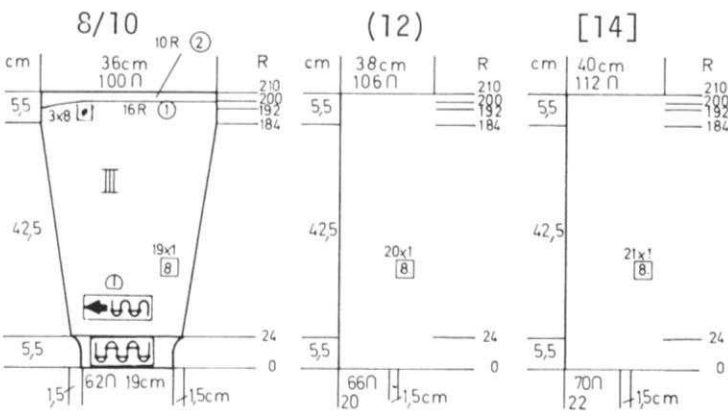
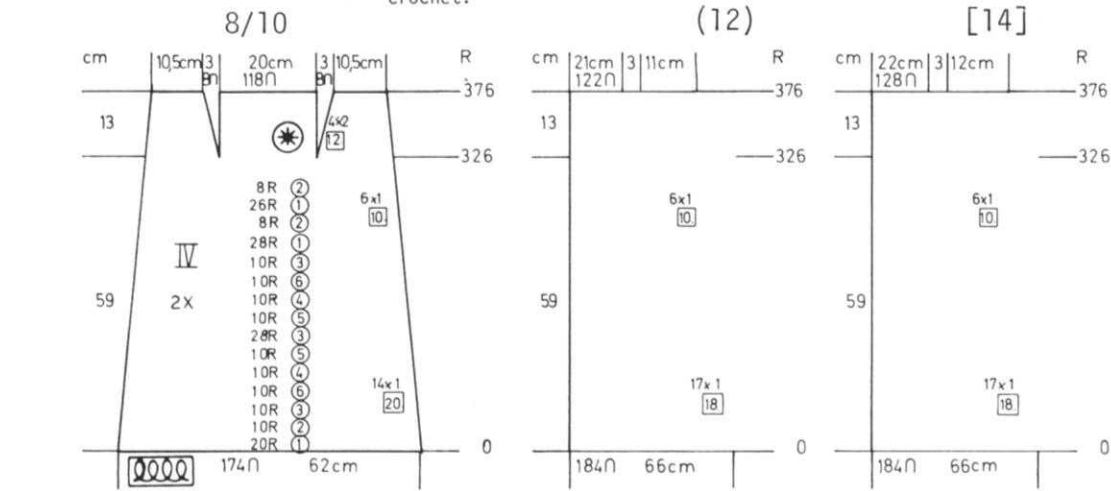

SLEEVES: III Make 1, reverse 1.

Cast on 62 (66) [70] sts. with color 1 and work 24 rows K1, P1 Ribbing. After Row 24, continue in Stockinette stitch.  
 ON EACH SIDE, increase 1 st. every 8th row 19x (20x) [21x].  
 After Row 184, work the next 16 rows with color 1 in stockinette and the last 10 rows with color 2 in Pattern. AT THE SAME TIME, After Row 192, on the LEFT (right for 2nd sleeve) work SHORT ROWS. Put into holding position, 8 sts. 3x, then bring all the sts. back into working position.  
 After Row 210, bind off all sts.



COLLAR:

Cast on 112 (112) [116] sts. with color 2 and work 8 rows in Pattern then 50 rows Stockinette stitch with color 1. Bind off.





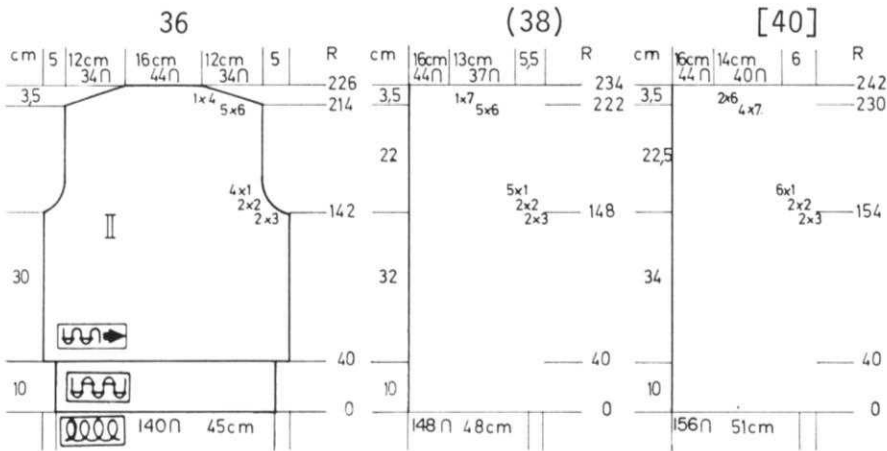

**JACKET BACK: II**

Cast on 140 (148) [156] sts. with color 1 and work 40 rows K2, P2 (or K1, P1) ribbing. Continue in Stockinette stitch.  
 Knit to Row 142 (148) [154].  
**SHAPE ARMHOLE: ON EACH SIDE, bind off** 3 sts. 2x, 2 sts. 2x, 1 st. 4x. (3 sts. 2x, 2 sts. 2x, 1 st. 5x). [3 sts. 2x, 2 sts. 2x, 1 st. 6x].  
 Knit to Row 214 (222) [230].  
**SHAPE SHOULDER: ON EACH SIDE, bind off** 6 sts. 5x, 4 sts. 1x. (6 sts. 5x, 7 sts. 1x). [7 sts. 4x, 6 sts. 2x].  
 After Row 226 (234) [242], bind off the remaining sts.

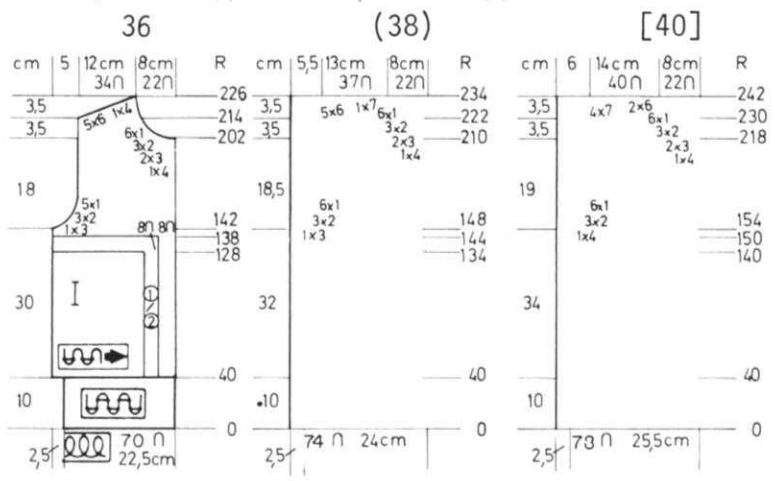

**JACKET FRONT: II** Make 1, reverse 1.

Cast on 70 (74) [78] sts. with color 1 and work 40 rows K2, P2 (or K1, P1) ribbing. Continue in Stockinette stitch with the 9th to the 16th stitches, counting from the right (left for 2nd half) in the Norwegian Design.  
 Knit to Row 128 (134) [140] then work the Norwegian Design from the 9th across to the left (right) to Row 138 (144) [150] then continue in Stockinette stitch over all the stitches.  
 After Row 141 (147) [153],  
**SHAPE ARMHOLE: Bind off** 3 sts. 1x, 2 sts. 3x, 1 st. 5x. (3 sts. 1x, 2 sts. 3x, 1 st. 6x). [4 sts. 1x, 2 sts. 3x, 1 st. 6x].  
 After Row 202 (210) [218],  
**SHAPE NECK: Bind off for all sizes,** 4 sts. 1x, 3 sts. 2x, 2 sts. 3x, 1 st. 6x, and After Row 213 (221) [229], **SHAPE SHOULDER** same as the back.

# dk 700

**WOMAN'S SKIRT & JACKET**

**SIZES:** 10/12 (14/16)  
**YARN:** Vienna  
**GRAMS:** 850 900  
**TENSION:** 4 to 6  
**GAUGE:** 15 sts. 21 rows = 5 cm (2")

**FINISHING:** See General Instructions.  
 Sew in darts on front and back sections of skirt then sew on waistband. Sew pockets on Jacket (see Picture). Sew on Front bands and leave openings on right front for buttonholes. Sew on Collar.

Stockinette stitch worn on the purl side. Bands are K2, P2 (or K1, P1) Ribbing.

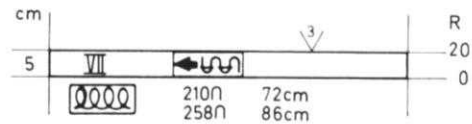

**SKIRT WAISTBAND: VII**

Cast on 210 (258) sts. half on the main machine and half on the Ribber and work 20 rows K2, P2 (or K1, P1) Ribbing then bind off.

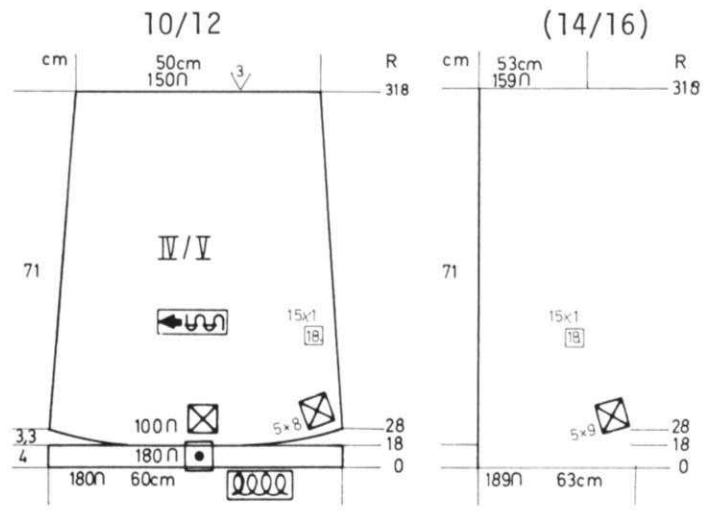

**SKIRT FRONT & BACK -2 sections the same.**

Cast on 180 (189) sts. and work Stockinette stitch.  
 Knit to Row 18, then REVERSE THE KNITTING and continue.  
**WORK SHORT ROWS: ON OPPOSITE SIDE OF SLIDE, put into holding position** 40 (45) sts. before knitting the next 2 rows.  
**ON OPPOSITE SIDE OF SLIDE, bring back** into working position 8 (9) sts. 5x ON EACH SIDE.  
**ON EACH SIDE, decrease 1 st. every** 18th row 15x.  
 After Row 318, bind off the remaining sts.



# dk 700

10/12

(14/16)

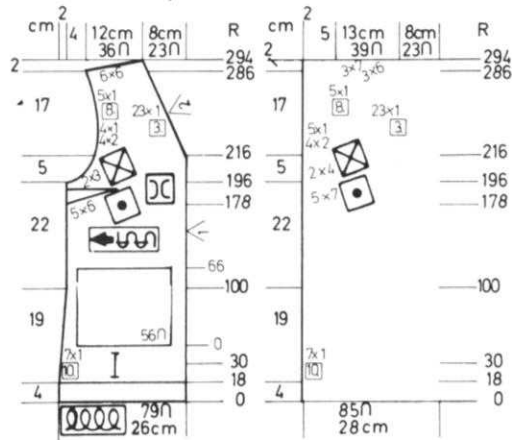

JACKET FRONT: Make 1, reverse 1.

Cast on 79 (85) sts. and work Stockinette stitch.  
After Row 18, REVERSE THE KNITTING THEN CONTINUE.  
After Row 30, ON EACH SIDE, decrease 1 st. every 10th row 7x.  
Knit to Row 178.  
WORK SHORT ROWS FOR THE BUST DART.  
ON OPPOSITE SIDE OF SLIDE, put into holding position,  
6 (7) sts. 5x.  
Bring all the needles back into working position and knit to Row 195.  
SHAPE ARMHOLE: ON ARM SIDE, bind off 3 sts. 2x, 2 sts. 4x, 1 st. 4x, (4 sts. 2x, 2 sts. 4x, 1 st. 5x), AT THE SAME TIME, after Row 216, SHAPE FRONT EDGE: Decrease 1 st. every 3rd row 23x.  
ON ARM SIDE, increase 1 st. every 8th row 5x.  
After Row 287, SHAPE SHOULDER same as the back.

POCKETS: Make 2.

Cast on 56 sts. and work 66 rows K2, P2 (or K1, P1) Ribbing. then bind off.

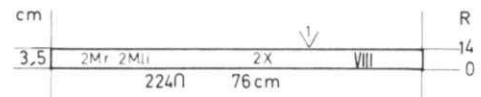

FRONT BANDS: Make 2. VII

Cast on 224 sts. half on the main machine and half on the Ribber and work 14 rows K2, P2 (or K1, P1) Ribbing. Bind off

JACKET BACK:

Cast on 158 (170) sts. and work Stockinette stitch. Knit to Row 18, then REVERSE THE KNITTING and continue.  
After Row 30, ON EACH SIDE, decrease 1 st. every 10th row 7x.  
Knit to Row 186.  
SHAPE ARMHOLE: ON EACH SIDE, bind off 3 sts. 1x, 2 sts. 2x, 1 st. 5x. (4 sts. 1x, 2 sts. 3x, 1 st. 5x).  
Knit to Row 272. SHAPE SHOULDER and WATCH FOR NECK SHAPING.  
FOR SHOULDER: ON EACH SIDE, bind off 6 sts. 6x, (7 sts. 3x, 6 sts. 3x),  
After Row 276, put half the sts. on the left into holding position and complete the right side first.  
\*ON NECK SIDE, bind off 12 sts. 1x, 4 sts. 3x (all sizes).  
Bring the needles on the left into working position, knit 1 row to the left side, turn the Row Counter back to 276 and complete the left half. Follow the instructions from \* and don't forget to complete the shoulder shaping.

10/12

(14/16)

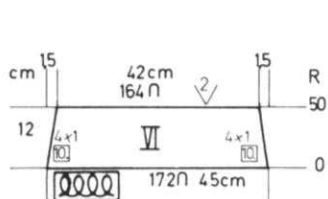

COLLAR:

Cast on 172 sts. half on the main machine and half on the Ribber. Work K2, P2 or K1, P1 Ribbing. ON EACH SIDE, decrease 1 st. every 10th row 4x. After Row 50, bind off

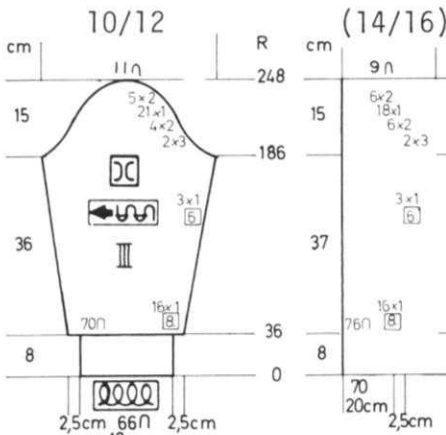
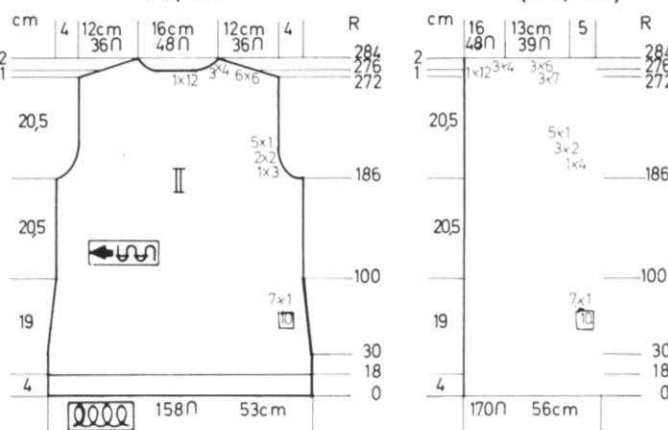

SLEEVES: III

Cast on 70 (76) sts. and work 36 Rows K2, P2 (or K1, P1) Ribbing. Continue in Stockinette stitch. ON EACH SIDE, increase 1 st. every 8th row 16x, every 6th row 3x. After Row 186 (190), SHAPE CAP: ON EACH SIDE, bind off 3 sts. 2x, 2 sts. 4x, 1 st. 21x, 2 sts. 5x. (3 sts. 2x, 2 sts. 6x, 1 st. 18x, 2 sts. 6x). After Row 248 (252), bind off the remaining sts.

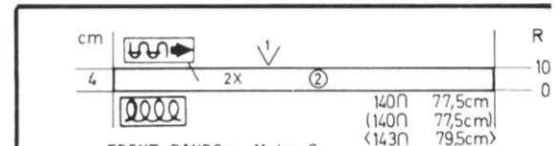

FRONT BANDS: Make 2.

Cast on 140 (140) [143] sts. with color 2 over EVERY NEEDLE and work 10 rows Stockinette stitch. Bind off.

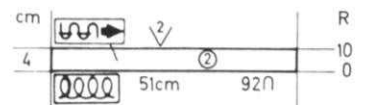

BACK NECK BAND:

Cast on 92 sts. with color 2 over EVERY NEEDLE and work 10 rows Stockinette stitch. Bind off.

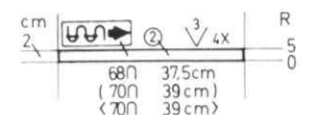

RAGLAN BANDS: MAKE 4

Cast on 68 (70) [70] sts. with color 2 over EVERY NEEDLE and work 5 rows Stockinette stitch. Bind off.

PUNCH CARD ON PAGE 41

# dk 701

WOMAN'S JACKET

SIZES: 10/12 (14) [16]  
YARN: Color 1 = Alanda Tweed  
Color 2 = Euro Sport  
GRAMS: color 1 1000 1050 1100  
color 2 150 150 150  
TENSION: 9 or 10  
GAUGE: Pat: 9 sts. 12 rows = 5 cm (2")  
Stock: 12 sts. 15 rows = 5 cm (2")

A Weaving Pattern OVER EVERY OTHER NEEDLE. Punch your own Card and use SINGLE STRAND OF YARN FOR KNITTING and DOUBLE STRAND OF YARN FOR WEAVING. The bands are Stockinette stitch over EVERY NEEDLE.

FINISHING: See General Instructions. Fold sleeve and lower band to the right side and sew in place. Sew in Raglan Band to fronts and back then sew in sleeves. Fold front bands and neckband in half and sew 1 edge to inside and 1 to the outside of garment.





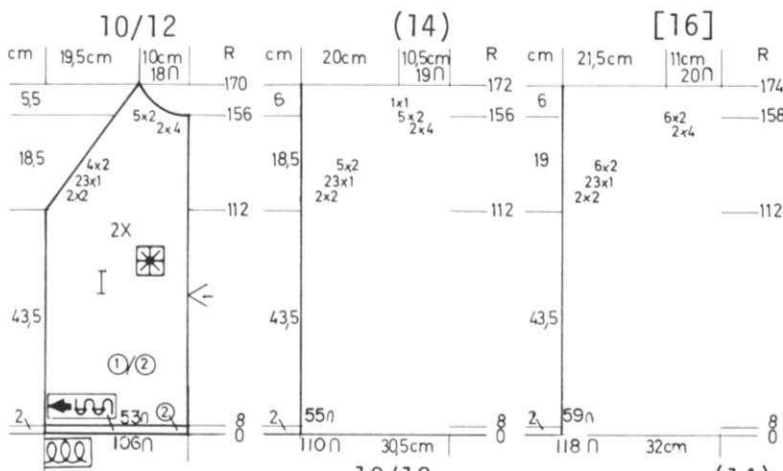

JACKET FRONT: I Make 1, reverse 1.

Cast on 106 (110) [118] sts. with color 2 over EVERY NEEDLE and work 8 rows Stockinette stitch. Transfer the sts. as you did for back and continue in the Weaving Pattern. 53 (55) [59] sts. Knit to Row 113.  
 SHAPE RAGLAN: Bind off 2 sts. 2x, 1 st. 23x, 2 sts. 4x, (2 sts. 2x, 1 st. 23x, 2 sts. 5x), [2 sts. 2x, 1 st. 23x, 2 sts. 6x], AT THE SAME TIME, after Row 156 (156) [158], SHAPE NECK: Bind off 4 sts. 2x, 2 sts. 5x. (4 sts. 2x, 2 sts. 5x, 1 st. 1x). [4 sts. 2x, 2 sts. 6x].

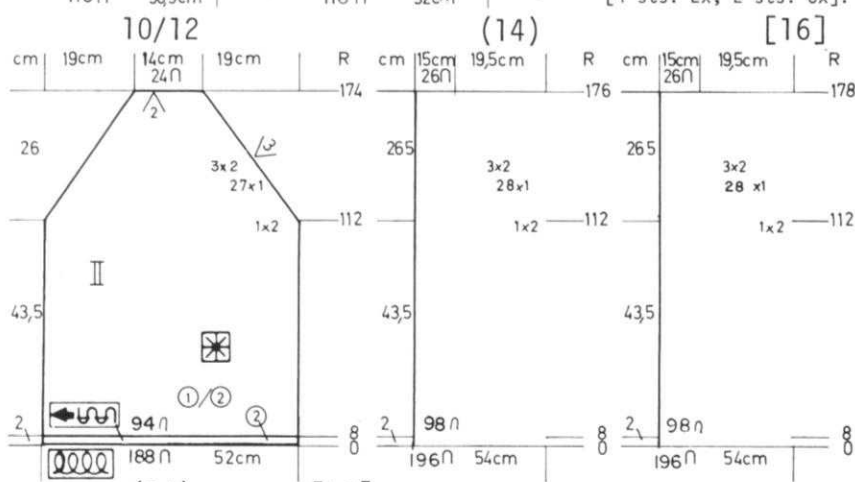

JACKET BACK: II

Cast on 188 (196) [196] sts. with color 2 over EVERY NEEDLE and work 8 rows stockinette stitch. Transfer every other st. to its neighboring needle and put the empty needles to the OUT OF WORK POSITION. Continue in Weaving pattern with single strand of color 1 in feeder and double strand for weaving. Knit to Row 112.  
 SHAPE RAGLAN: ON EACH SIDE, bind off 2 sts. 1x, then decrease 1 st. 27x (28x) [28x], then bind off 2 sts. 3x. After Row 174 (176) [178], bind off the remaining sts.

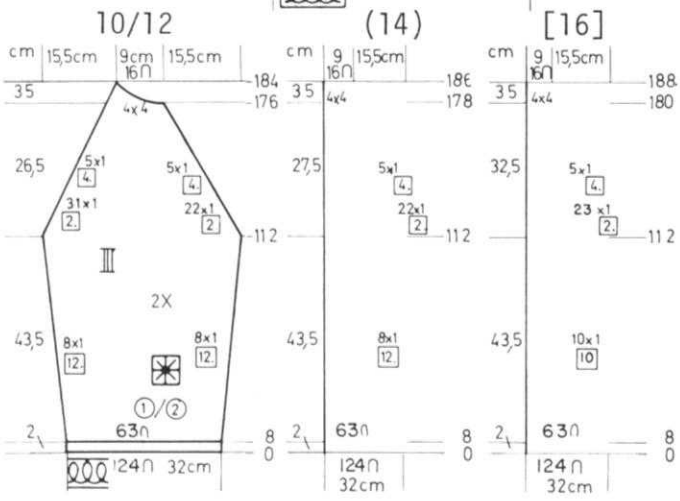

SLEEVES: III Make 1, reverse 1.

Cast on 124 sts. with color 2 over EVERY NEEDLE and work 8 rows Stockinette stitch. Transfer the sts. as you did for the back and continue in Weaving Pattern over 63 sts. ON EACH SIDE, increase 1 st. every 12th row 8x. (every 12th row 8x.) [every 10th row 10x]. Knit to Row 112.  
 SHAPE RAGLAN: Please follow the CHART for the DIFFERENT shapings on each side for YOUR SIZE. After Row 175 (177) [179], work SHORT ROWS. ON OPPOSITE SIDE OF SLIDE, put into holding position 4 sts. 4x for all sizes. Bring all the needles back into working position and bind off loosely.



dk 702

PUNCH CARD ON PAGE 40

WOMAN'S TRIANGLE SHAWL

YARN: Micaela  
 GRAMS: 500  
 TENSION: 5 to 7  
 GAUGE: Not important

A Tuck stitch Pattern. Punch your own Card and push in BOTH TUCK Buttons.

FINISHING: Crochet across wide edge pulling in a bit to fit neck. Sew Fringe doubled - 1 edge to inside and 1 to outside of shawl (see Picture). Cut Fringe.

To the extreme left of machine, cast on 4 sts. Knit 4 rows then begin Pattern.

ON THE RIGHT, increase 1 st. every 2nd row until 200 sts. are in work, then decrease 1 st. every 2nd row till 4 remain. End with 4 rows over the 4 sts. Bind off.

FRINGE: Cast on 3 sts, then leave empty needles between and cast on 3 more sts. You can make the fringe as long as you like - this will depend on the empty needles between. Remember that the fringe is doubled.  
 Knit 2 rows over the 6 needles in work.

\*Put the center needle of each group of 3 needles into holding position and knit 4 rows.

All needles in work, knit 1 row. REPEAT from \* for as long as you need for edge of Shawl. Bind off.



# dk 703

PUNCH CARD ON PAGE 40

## WOMAN'S PULLOVER & SKIRT

SIZES: 8 (10) [12]  
 YARN: Vienna  
 GRAMS: 900 900 950  
 TENSION: 7 to 8  
 GAUGE: 17 sts. 12 rows = 5 cm (Pat).  
 14 sts. 20 rows = 5 cm (Stock).

The Pullover is a TUCK Stitch Design using Punch Card and RIBBER. Punch your own Card. Lower Band and Sleeve bands of Pullover are K3, P3 and the Pattern is worked with same needle set-up of 3 needles of Ribber and 3 needles of main machine.

FINISHING: See General Instructions. Weave the open sts. of skirt then remove the waste yarn.

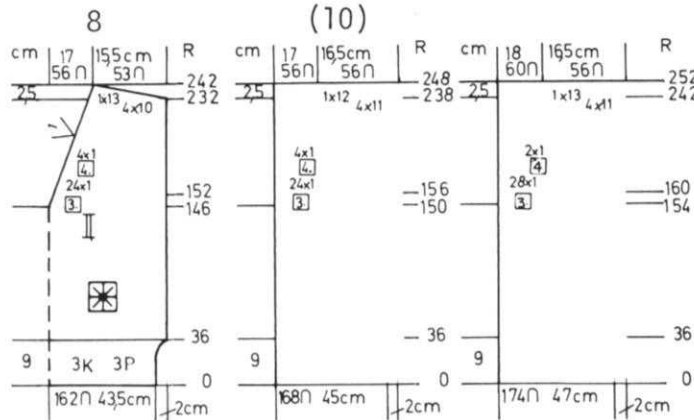

PULLOVER FRONT: II Make 1, reverse 1.

Cast on 162 (168) [174] sts. and work K3, P3, Ribbing to Row 36. Continue in Pattern as you did for the back.  
 After Row 146 (150) [154], divide in the center. Remove the left half stitches onto a stitch holder and be sure to mark the needles where you will replace them later.  
 Complete the right half first.  
 ON NECK SIDE, decrease 1 st. every 3rd row 24x, every 4th row 4x. (every 3rd row 24x, every 4th row 4x). [every 3rd row 28x, every 4th row 2x].  
 After Row 232 (238) [242], SHAPE SHOULDER same as the back.

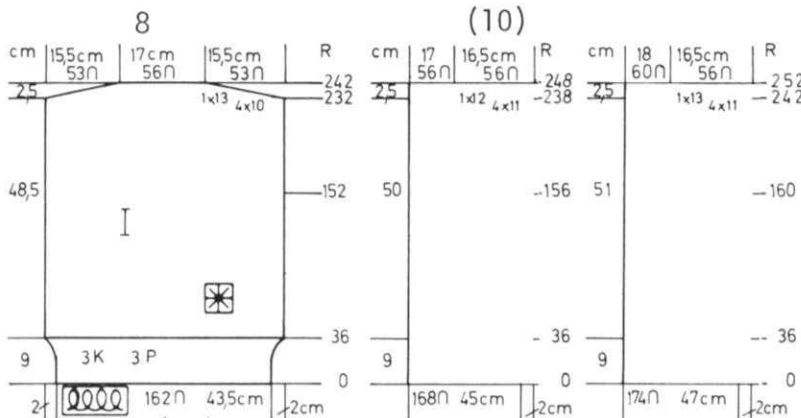

PULLOVER BACK: I

Cast on 162 (168) [174] sts. and work 36 rows K3, P3 Ribbing. DO NOT TRANSFER the Ribber sts. but Continue in PATTERN.  
 Mark Row 152 (156) [160] ON EACH SIDE for setting in sleeves.  
 Knit to Row 232 (238) [242].  
 SHAPE SHOULDER: ON EACH SIDE, bind off 10 sts. 4x, 13 sts. 1x. (11 st. 4x, 12 sts. 1x). [11 sts. 4x, 13 sts. 1x].  
 After Row 242 (248) [252], bind off the remaining sts.

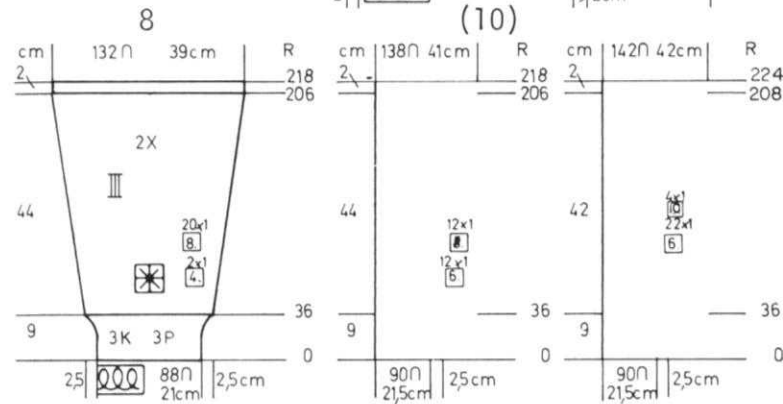

SLEEVES: III Make 2.

Cast on 88 (90) [90] sts. and work K3, P3 to Row 36. Continue in Pattern as you did for front and back.  
 ON EACH SIDE, increase 1 st. every 4th row 2x, every 8th row 20x. (every 6th row 12x, every 8th row 12x). [every 6th row 22x, every 10th row 4x].  
 After Row 206 (206) [208], work K3, P3 to Row 218 (218) [224]. Bind off.

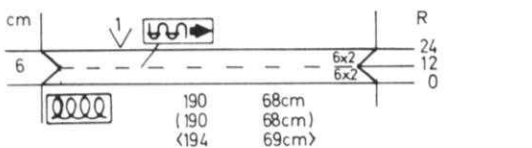

NECKBAND:

Cast on 190 (190) [194] sts. and work Stockinette stitch. ON EACH SIDE, decrease 2 sts. every 2nd row 6x. After Row 12, ON EACH SIDE, increase 2 sts. every 2nd row 6x. After Row 24, bind off.

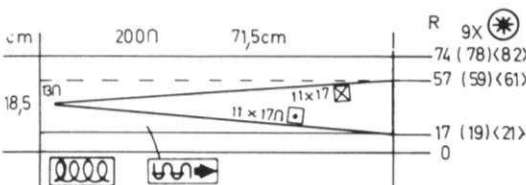

SKIRT:

With contrast waste yarn, cast on 200 sts. Knit 8 to 10 rows, change to garment yarn and put Counter at 0.  
 Work Stockinette stitch.  
 \*Knit to Row 17 (19) [20].  
 WORK SHORT ROWS: ON OPPOSITE SIDE OF SLIDE, put into holding position 17 sts. 11x (and be sure to wrap the yarn around inside needle in holding when working all short rows). ON OPPOSITE SIDE OF SLIDE, bring back into working position, 17 sts. 11x.  
 Knit to Row 74 (78) [82]. REPEAT FROM \* 9x more.  
 Remove the sts. onto contrast waste yarn.

# dk 704

WOMAN'S PULLOVER

SIZES: 7/8 (10)  
 YARN: Crocus Crepe  
 GRAMS:  
 color 1 300 350  
 color 2 150 150  
 color 3 150 150  
 color 4 100 100  
 color 5 100 100  
 TENSION: 7 to 9 Stock.  
 8 to 10 Norwegian.  
 GAUGE: 14 sts. 16 rows = 5 cm (2") Stock.

Repeated Color Stripes and a Norwegian Design. Follow the color changes and rows as given. Bands are K2, P2 (or K1, P1) Ribbing as is the Collar.

FINISHING: See General Instructions. Sew in Pocket Lining.

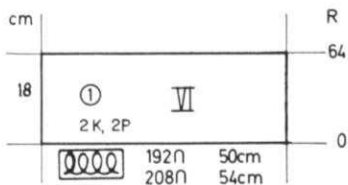

POCKET LINING: VII

Cast on 72 (78) sts. with color 1 and work 60 rows Stockinette stitch then bind off.

POCKET BANDS:

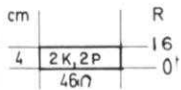

Cast on 46 sts. with color 1 (or you can pick up the sts. along pocket opening) and work 16 rows K2, P2 (or K1, P1) Ribbing. Bind off.

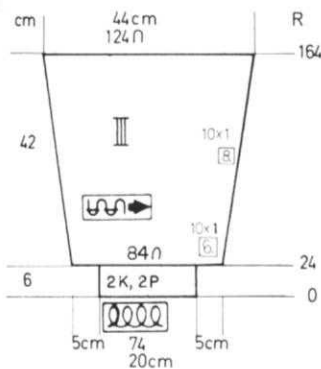

PULLOVER BACK: II

Cast on 132 (138) sts. with color 1 and work 24 rows K2, P2 (or K1, P1) Ribbing.

Continue in Pattern and Color Stripes as listed.

Knit to Row 140 then mark each side with bit of contrast waste yarn for setting in sleeves.

After Row 210 SHAPE SHOULDER and NECK AT THE SAME TIME.

Put half the sts. on the left into holding position and complete the right side first.

\*FOR SHOULDER, bind off

8 sts. 4x, 9 sts. 1x.

FOR NECK, bind off

13 (16) sts. 1x, 4 sts. 3x.

Bring the needles on the left into working position, knit 1 row to the left side, turn the Row Counter back to 210 and complete the left half.

Follow the instructions from \*

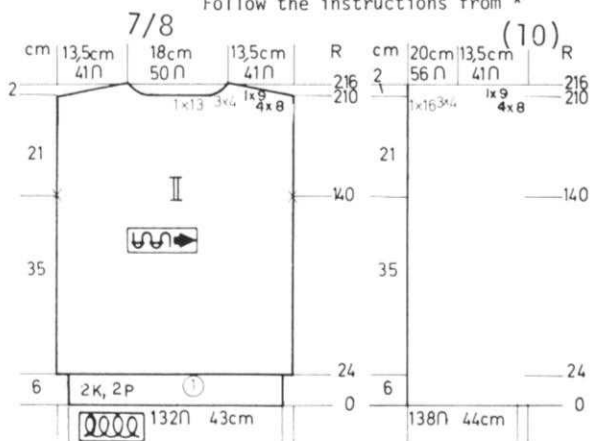

PULLOVER FRONT:

Cast on 132 (138) sts. with color 1 and work 24 rows K2, P2 (or K1, P1) Ribbing.

Continue in Pattern as for the back but divide as follows for working pocket openings.

Put all but 30 sts. on the right into holding position. Work 56 rows. Put these sts. into holding position and work over the next 72 (78) sts. 56 rows. Put these sts. into holding and work 56 rows over the last 30 sts. Counter at Row 80.

Bring all the needles into working position and continue in Pattern as given.

After Row 190, put half the sts. on the left into holding position and complete the right side first.

\*ON NECK SIDE, bind off

6 sts. 1x, 3 sts. 2x, 2 sts. 4x, 1 st. 5x. (8 sts. 1x, 3 sts. 3x, 2 sts. 3x, 1 st. 5x).

After Row 210, SHAPE SHOULDER same as the back.

Bring the needles on the left into working position, knit 1 row in Pattern to the left side, turn the Row Counter back to 190 and complete the left half. Follow the instructions from \*.

AFTER KNITTING THE BAND, WORK FRONT & BACK COLOR CHANGES & ROWS AS FOLLOWS:

- 4 rows color 2
- 2 rows color 3
- 2 rows color 4
- 14 rows colors 5 & 4 (Nor.)
- 2 rows color 4
- 16 rows color 1
- 16 rows color 2
- 16 rows color 3
- 6 rows color 1
- 4 rows color 2
- 2 rows color 4
- 2 rows color 5
- 2 rows color 5
- 14 rows color 5 & 1 (Nor.)
- 2 rows color 5
- 2 rows color 4
- 4 rows color 2
- 6 rows color 1

- \*2 rows color 2
  - 2 rows color 5
  - 2 rows color 4
  - 2 rows color 3
  - 2 rows color 1
- REPEAT FROM \* 7x.

SLEEVES - AFTER KNITTING THE SLEEVE BANDS, WORK THE COLOR CHANGES AS FOLLOWS:

- 4 rows color 2
  - 2 rows color 3
  - 2 rows color 4
  - 14 rows colors 5 & 4 (Nor.)
  - 2 rows color 4
  - 4 rows color 3
  - 6 rows color 5
  - 2 rows color 3
  - 2 rows color 5
  - 4 rows color 1
  - 2 rows color 4
  - 2 rows color 5
  - 2 rows color 3
  - \*2 rows color 1
  - 2 rows color 2
  - 2 rows color 5
  - 2 rows color 4
  - 2 rows color 3
- REPEAT FROM \* 8x.

SLEEVES: III

With contrast waste yarn, cast on 84 sts. Knit 8 to 10 rows, change to garment yarn, put Counter at 0 and work the color stripes and Pattern as given for the sleeves.

ON EACH SIDE, increase 1 st. every 6th row 10x, every 8th row 10x. After Row 164, bind off.

Hang the open sts. of the sleeve back onto the machine, DECREASING 10 sts. evenly across. Work 24 rows K2, P2 (or K1, P1) Ribbing, then bind off.

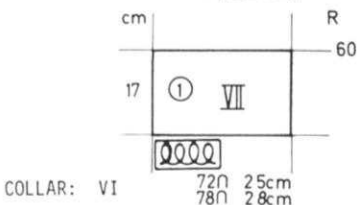

COLLAR: VI

Cast on 192 (208) sts. with color 1 and work 64 rows K2, P2 (or K1, P1) ribbing then bind off.



MAN'S JACKET

SIZES: 38/40 (42/44) [46/48]  
 YARN: Crocus Crepe  
 GRAMS: 900 950 1000  
 TENSION: 9 or 10  
 GAUGE: 11 sts. 21 rows = 5 cm (2")

A Tuck Stitch Pattern. Punch your own Card and push in BOTH Tuck Buttons. Bands and Collar are K1, P1 Ribbing.

FINISHING: See General Instructions. Sew side seams, leaving opening for pockets. Turn the 6 sts. of pocket opening on fronts to the inside and sew in place. Sew pocket linings to the inside. Run elastic thread through on the inside above waistband to pull in then fold waistband in half and sew to the inside. Work single crochet down the front edges then sew in jacket type zipper. Sew l edge of collar to the inside and l to the outside of neckline. Work single crochet along top edge of pocket.

PUNCH CARD ON PAGE 41



hp 705

# hp 705

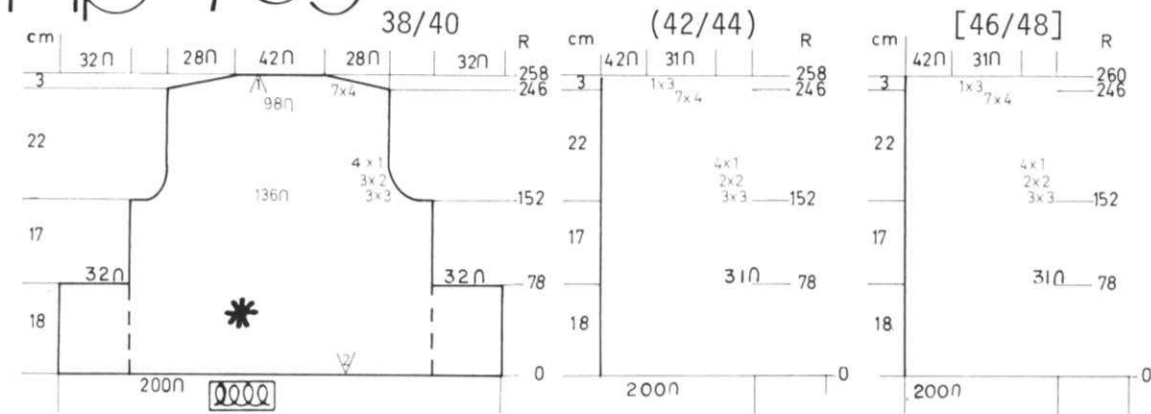

## JACKET BACK:

Cast on 200 sts. with contrast waste yarn. Knit 8 to 10 rows, change to garment yarn and put Counter at 0. Continue in Pattern. Knit to Row 78. ON EACH SIDE, bind off 32 (31) [31] sts. then knit to Row 152. SHAPE ARMHOLE: ON EACH SIDE, bind off 3 sts. 3x, 2 sts. 3x, 1 st. 4x. (3 sts. 3x, 2 sts. 2x, 1 st. 4x). [3 sts. 3x, 2 sts. 2x, 1 st. 4x]. After Row 246, SHAPE SHOULDER: ON EACH SIDE, bind off 4 sts. 7x. (4 sts. 7x, 3 sts. 1x). [4 sts. 7x, 3 sts. 1x]. After Row 258 (258) [260], bind off the remaining sts.

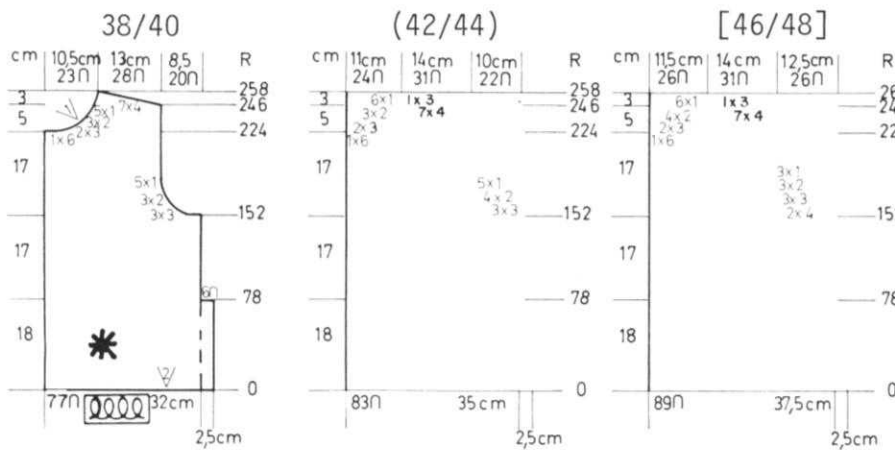

## JACKET FRONT: Make 1, reverse 1.

Cast on 77 (83) [89] sts. with waste yarn as you did for the back. Continue in Pattern. After Row 78, bind off 6 sts. on the right (left for 2nd section). Knit to Row 152. SHAPE ARMHOLE: Bind off 3 sts. 3x, 2 sts. 3x, 1 st. 5x. (3 sts. 3x, 2 sts. 4x, 1 st. 5x). [4 sts. 2x, 3 sts. 3x, 2 sts. 3x, 1 st. 3x]. Knit to Row 223. SHAPE NECK: Bind off 6 sts. 1x, 3 sts. 2x, 2 sts. 3x, 1 st. 5x. (6 sts. 1x, 3 sts. 2x, 2 sts. 3x, 1 st. 6x). [6 sts. 1x, 3 sts. 2x, 2 sts. 4x, 1 st. 6x]. After Row 246, SHAPE SHOULDER same as the back.

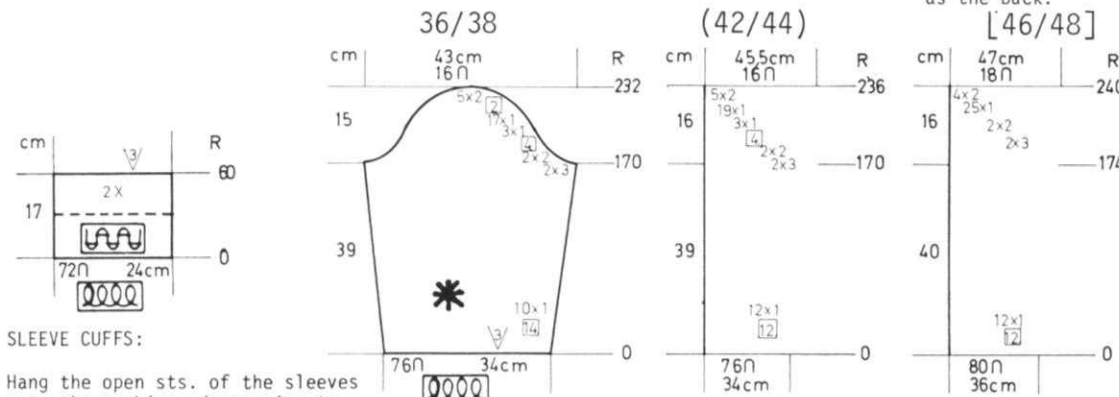

## SLEEVES:

Cast on 76 (76) [80] sts. with waste yarn as you did for back & front. Continue in Pattern. ON EACH SIDE, increase 1 st. every 14th row 10x. (every 12th row 12x). [every 12th row 12x]. After Row 170 (170) [174], SHAPE CAP: ON EACH SIDE, bind off 3 sts. 2x, 2 sts. 2x, 1 st. every 4th row 3x, then every 2nd row 1 st. 17x, 2 sts. 5x. (3 sts. 2x, 2 sts. 2x, 1 st. every 4th row 3x, then every 2nd row 1 st. 19x, 2 sts. 5x). [3 sts. 2x, 2 sts. 2x, 1 st. 25x, 2 sts. 4x]. After Row 232 (236) [240], bind off the remaining sts.

## SLEEVE CUFFS:

Hang the open sts. of the sleeves onto the machine, decreasing to 72 sts. Work 60 rows K1, P1 Ribbing then bind off.

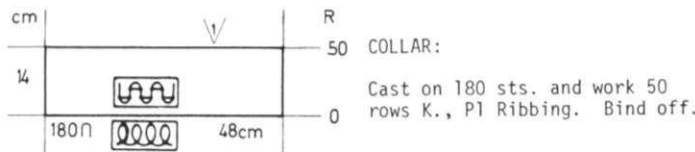
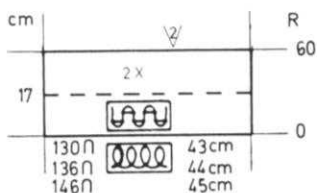

## COLLAR:

Cast on 180 sts. and work 50 rows K., P1 Ribbing. Bind off.

## JACKET WAISTBAND: Make 2.

Cast on 130 (136) [146] sts. and work 60 rows K1, P1 Ribbing. Bind off. Sew center back seam of band, pin to lower edge of jacket then sew in place through the open sts. doubling the sts. of jacket as needed and turning the sts. of POCKET LINING and POCKET FACING to the inside. Fold wasteband in half to the inside and sew in place.

# KK 706

## CHILD'S JACKET

SIZES: 3/4 (5/6) [7/8]  
YARN: Fortissima  
GRAMS: color 1 350 350 400  
color 2 Small amount for Engine Design  
TENSION: 5 to 7

GAUGE: 15 sts. 20 rows = 5 cm (2") Stock & Norwegian.  
13 sts. 30 rows = 5 cm (2") Tweed Stitch.

A Tuck Stitch Pattern with Norwegian Design Insert. Worn on the Purl side. The bands are Ribbed. Punch your own Cards.

FINISHING: See General Instructions.

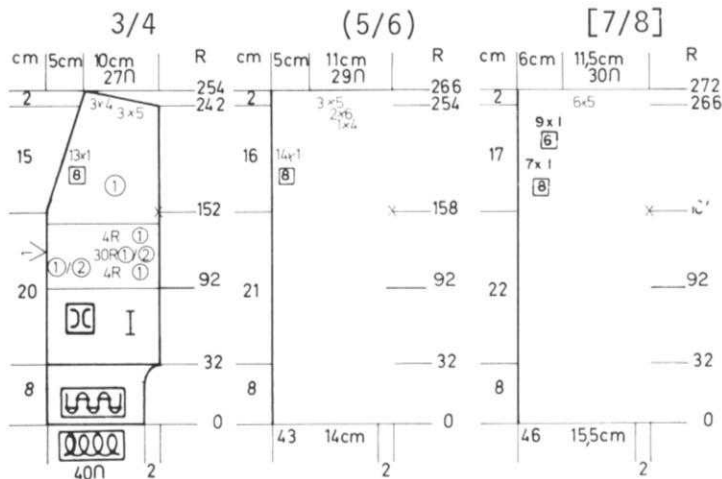

JACKET FRONT: I Make 1, reverse 1.

Cast on 40 (43) [46] sts. with color 1 and work 32 Rows K1, P1 Ribbing. Continue in Pattern to Row 92. Remove the sts. onto waste yarn (or you can take them off onto reversing bar) and reverse the knitting. work 4 rows Stockinette stitch with color 1 then work the Engine Motif only (omit the smoke) over needles 5 to 27 counting from the front edge (SINGLE MOTIF). Knit 4 rows color 1, then reverse the knitting as you did before and continue in TUCK PATTERN. After Row 152 (158) [164], mark side edge with contrast yarn as you did on back and ON NECK SIDE, decrease 1 st. every 8th row 13x. (every 8th row 14x). [every 8th row 7x, every 6th row 9x]. After Row 242 (254) [266], SHAPE SHOULDER same as the back.

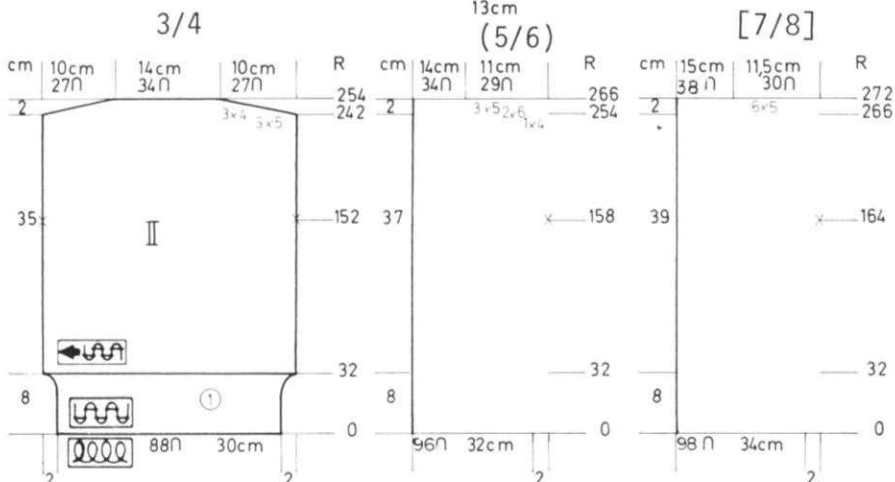

JACKET BACK: II

Cast on 88 (96) [98] sts. with color 1 and work 32 rows K1, P1 Ribbing. Continue in TUCK Pattern (Push in BOTH TUCK BUTTONS). Mark Row 152 (158) [164] ON EACH SIDE, for setting in sleeves. Knit to Row 242 (254) [266]. SHAPE SHOULDER: ON EACH SIDE, bind off 5 sts. 3x, 4 sts. 3x. (4 sts. 1x, 6 sts. 2x, 5 sts. 3x). [5 sts. 6x]. After Row 254 (266) [272], bind off the remaining sts.

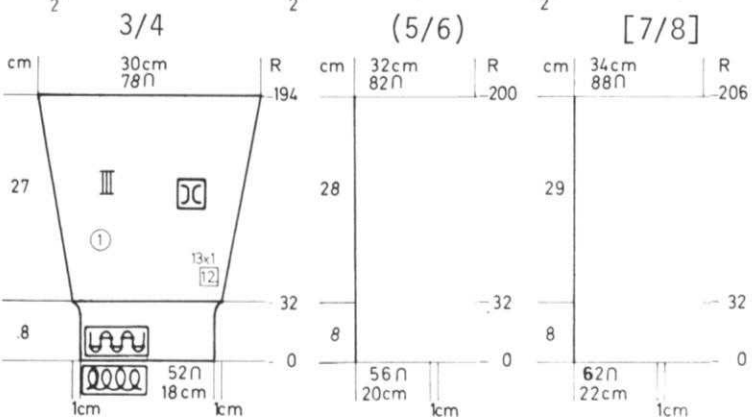

SLEEVES: III

Cast on 52 (56) [62] sts. with color 1 and work 32 rows K1, P1 Ribbing. Continue in Tuck Pattern. ON EACH SIDE, increase 1 st. every 12th row 13x. After Row 194 (200) [206], bind off the remaining sts.

FRONT BAND:

Cast on 174 (180) [186] sts. with color 1 and work 14 rows K1, P1 Ribbing. Bind off.

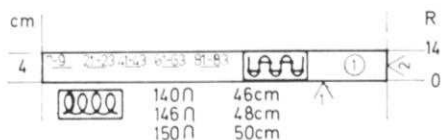

BUTTONHOLE BAND:

Cast on 140 (146) [150] sts. with color 1 and work K1, P1 Ribbing. After Row 7, make BUTTONHOLES over needles 7 to 9, 21 to 23, 41 to 43, 61 to 63, 81 to 83, counting from the left edge. After Row 14, bind off.



PUNCH CARD ON PAGE 41

KK 707

GIRL'S DRESS

SIZES: 6 (7) [8]  
 YARN: Euro Sport  
 GRAMS: color 1 350 350 400  
 color 2 50 50 50  
 color 3 50 50 50  
 TENSION: 9 or 10  
 GAUGE: 12 sts. 16 rows = 5 cm (2")

Stockinette stitch with a Tuck Stitch Pattern for the Yoke. Punch your own Card and push in BOTH Tuck Buttons for Pattern. Sleeve Cuffs are Ribbed. Dress is worn on the Purl side.

FINISHING: See General Instructions. Work 2 rows single crochet around neck opening, making buttonholes (5) on one edge - sew buttons to the other side. Work 1 row single crochet around neckline then 1 row of Shell Stitch Crochet.



PUNCH CARD ON PAGE 41



# KK 707

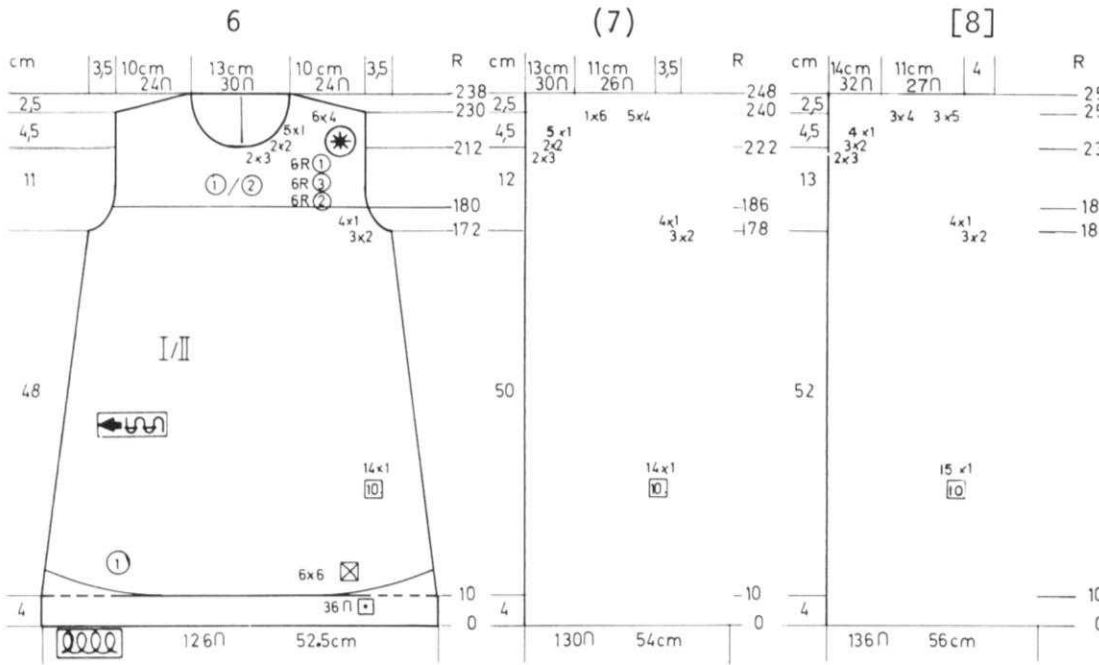

## DRESS BACK AND FRONT

The front and back of dress are worked in the same way except for the NECK SHAPING.

Cast on 126 (130) [136] sts. with color 1 and work Stockinette stitch. Knit to Row 10, then work SHORT ROWS. ON OPPOSITE SIDE OF SLIDE, put into holding position, 36 sts. before knitting the next 2 rows. ON OPPOSITE SIDE OF SLIDE, bring back into working position, 6 sts. 6x ON EACH SIDE. ON EACH SIDE, decrease 1 st. every 10th row 14x (every 10th row 15x). Knit to Row 172 (178) [184]. SHAPE ARMHOLE: ON EACH SIDE, bind off 2 sts. 3x, 1 st. 4x for all sizes. After Row 180 (186) [188], begin Pattern with REPEATED color changes as shown on the Chart. After Row 212 (222) [232], DIVIDE in the Center for BACK NECK opening. Remove the sts. on the left side onto waste yarn or you can put them into holding position by knitting a row with waste yarn BY HAND and leave the needles against the back rail of the machine.

Complete the right side first. \*After Row 230 (240) [250], SHAPE SHOULDER, bind off 4 sts. 6x.

(4 sts. 5x, 6 sts. 1x). [5 sts. 3x, 4 sts. 3x]. After Row 238 (248) [258], bind off the remaining sts.

Bring the needles on the left into working position, knit 1 row in Pattern to the left side, turn the Row Counter back to 212 (222) [232] and complete the left half. Follow the instructions from \*

## FRONT NECK SHAPING:

After Row 212 (222) [232], Put half the sts. on the left into holding position and complete the right side first. \*ON NECK SIDE, bind off 3 sts. 2x, 2 sts. 2x, 1 st. 5x. [3 sts. 2x, 2 sts. 2x, 1 st. 5x]. [3 sts. 2x, 2 sts. 3x, 1 st. 4x]. After Row 230 (240) [250], SHAPE SHOULDER SAME AS THE BACK. Bring the needles on the left into working position, knit 1 row in pattern to the left side, turn the Row Counter back to 212 (222) [232] and complete the left half. Follow the instructions from \*.

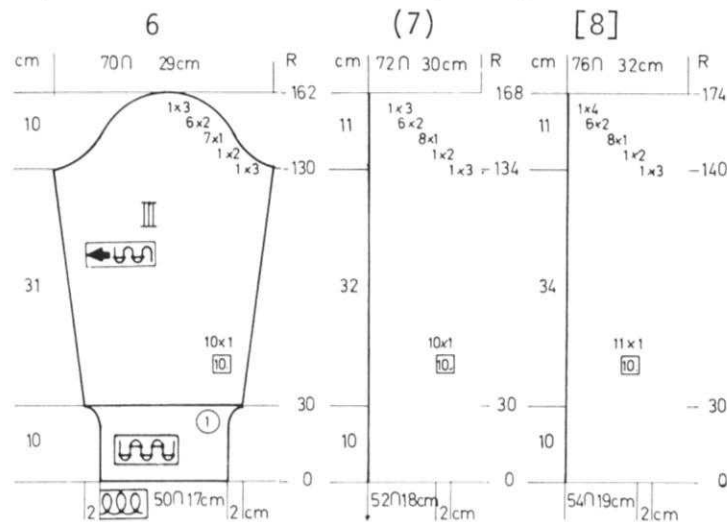

## SLEEVES: III

Cast on 50 (52) [54] sts. with color 1 and work 30 rows K1, P1 Ribbing. Continue in Stockinette stitch. ON EACH SIDE, increase 1 st. every 10th row 10x (10x) [11x]. After Row 130 (134) [140], SHAPE CAP: ON EACH SIDE, bind off 3 sts. 1x, 2 sts. 1x, 1 st. 7x, 2 sts. 6x, 3 sts. 1x. (3 sts. 1x, 2 sts. 1x, 1 st. 8x, 2 sts. 6x, 3 sts. 1x). [3 sts. 1x, 2 sts. 1x, 1 st. 8x, 2 sts. 6x, 4 sts. 1x]. After Row 162 (168) [174], bind off the remaining sts.

# KK 708

## BOY'S JACKET

SIZES 7/8 (10) [12]  
 YARN: Crocus Crepe  
 GRAMS: 500 550 600  
 TENSION: 9 or 10  
 GAUGE: 12 sts. 14 rows = 5 cm (2") Weaving.  
 12 sts. 28 rows = 5 cm (2") Tuck Pattern.

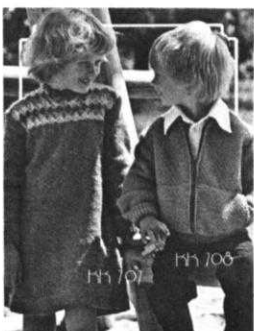

A Tuck Stitch Pattern combined with Weaving Pattern. Punch your own Card. Bands are Ribbed. Worn on the Purl side.

FINISHING: See General Instructions. Crochet around edges of pockets then sew in place. Work 2 rows single crochet around neckline and front edges, then 1 row reverse single crochet. Sew in Zipper.

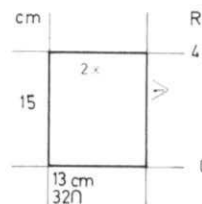

POCKET: Make 2.

Cast on 32 sts. and work in the Weaving Pattern. Knit to Row 42, then bind off.

PUNCH CARD ON PAGE 40



# KK 709

## GIRL'S PULLOVER & PANTS

SIZES: 5/6 (7/8)  
 YARN: Fortissima  
 GRAMS:  
 color 1 400 450  
 color 2 50 50  
 color 3 50 50  
 TENSION: 5 to 7  
 GAUGE: 17 sts. 20 rows = 5 cm (Stock).  
 13 sts. 34 rows = 5 cm (Pat.)

The front section of Pullover is in a Tuck Stitch with color changes as given. Punch your own Card. Back, Sleeves and Pants are Stockinette stitch. Bands are Ribbed.

FINISHING: See General Instructions. Leave left shoulder of Pullover open. Crochet around opening and insert small zipper. Make hem on lower edge of pants and hem at waist. Pull elastic through casing.



PUNCH CARD ON PAGE 41

### PULLOVER FRONT: I

Cast on 84 (90) sts. with color 1 and work 16 rows K1, P1 Ribbing. Transfer the Ribber sts. to main machine and work Stockinette stitch as follows:  
 2 rows color 1  
 \*2 rows color 2  
 2 rows color 3  
 2 rows color 1  
 2 rows color 3  
 2 rows color 2

BEGIN PATTERN: IMPORTANT- THE CARD IS PUNCHED FOR USE WITH THE COLOR CHANGER. If you do not own a Color Changer, REVERSE the holes when punching the Card.

In Pattern, work 2 rows color 1  
 \*\*2 rows color 3  
 2 rows color 2  
 2 rows color 1  
 AND REPEAT THE COLOR ROWS IN PATTERN 4x MORE from \*\*.

Set for Stockinette stitch and REPEAT THE COLOR STRIPES from \* 1x then REPEAT THE PATTERN from \*\* as GIVEN.

Continue in this way throughout the front of garment (see picture). After Row 150 (178) SHAPE ARMHOLE: ON EACH SIDE, bind off 2 sts. 3x, 1 st. 4x for both sizes. After Row 218 (246), put half the sts. on the left into holding position and complete the right side first.  
 \*ON NECK SIDE, bind off 5 sts. 1x, 3 sts. 1x, 2 sts. 1x, 1 st. 3x.  
 (6 sts. 1x, 3 sts. 1x, 2 sts. 2x, 1 st. 2x).  
 After Row 250 (278) SHAPE SHOULDER: Bind off 3 sts. 1x, 4 sts. 4x. (4 sts. 5x).  
 Bring the needles on the left into working position, knit 1 row in Pattern to the left side, turn the Row Counter back to 218 (246), and complete the left half. Follow the instructions from \*.

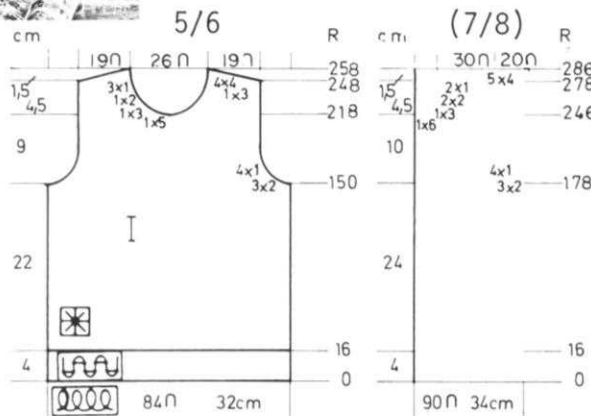

### PULLOVER BACK: II

Cast on 108 (116) sts. with color 1 and work 16 rows K1, P1 Ribbing. Continue in Stockinette stitch. Knit to Row 104 (112).  
 SHAPE ARMHOLE: ON EACH SIDE, bind off 3 sts. 1x, 2 sts. 3x, 1 st. 4x. (3 sts. 2x, 2 sts. 3x, 1 st. 3x). Knit to Row 158 (170).  
 Put half the sts. on the left into holding position and complete the right side first.  
 \*SHAPE SHOULDER AND NECK AT THE SAME TIME.  
 FOR SHOULDER, bind off 8 sts. 3x.  
 (8 sts. 2x, 9 sts. 1x).  
 FOR NECK, bind off 10 sts. 1x, 4 sts. 1x, 3 sts. 1x. (10 sts. 1x, 5 sts. 1x, 3 sts. 1x).  
 Bring the needles on the left into working position, knit 1 row to the right side, turn the Row Counter back to 158 (170) and complete the right half. Follow the instructions from \*.

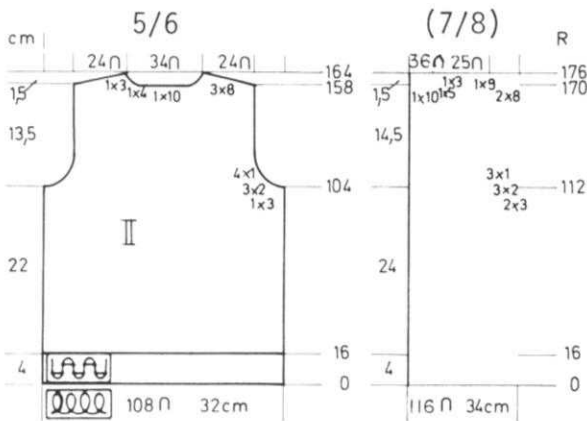

### NECKBAND:

Cast on 100 (106) sts. and work 24 rows K1, P1 Ribbing. Remove onto waste yarn (or you can bind off).

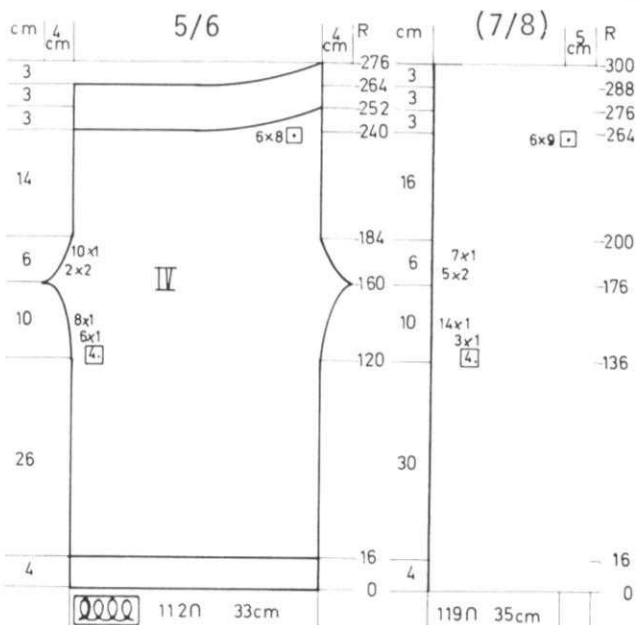

### PANTS: Make 1, reverse 1.

Cast on 112 (119) sts. with color 1 and work Stockinette stitch. Knit to Row 120 (136).  
 ON EACH SIDE, increase 1 st. every 4th row 6x, then every 2nd row 8x.  
 (every 4th row 3x, every 2nd row 14x).  
 After Row 160 (176), ON EACH SIDE, decrease 2 sts. 2x, 1 st. 10x. (2 sts. 5x, 1 st. 7x).  
 After Row 240 (264) work SHORT ROWS: ON OPPOSITE SIDE OF CAM BOX, put into holding position, 8 (9) sts. 6x.  
 Bring all the needles back into working position and knit to Row 276 (300). Bind off

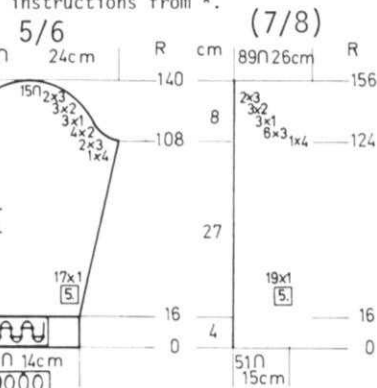

### SLEEVES: III

Cast on 47 (51) sts. and work 16 rows K1, P1 Ribbing. Continue in Stockinette stitch. ON EACH SIDE, increase 1 st. every 5th row 17x (19x).  
 After Row 108 (124) SHAPE CAP: ON EACH SIDE, bind off 4 sts. 1x, 3 sts. 2x, 2 sts. 4x, 1 st. 3x, 2 sts. 3x, 3 sts. 2x. (4 sts. 1x, 3 sts. 6x, 1 st. 3x, 2 sts. 3x, 3 sts. 2x).  
 After Row 140 (156), bind off the remaining sts.



# KK 710

## CHILD'S PULLOVER

SIZES: 3/4 (5/6)  
 YARN: Amore  
 GRAMS:  
 color 1 150 200  
 color 2 50 50  
 color 3 few yards  
 color 4 few yards  
 TENSION: 6 to 8  
 GAUGE: 16 sts. 24 rows = 5 cm (2")

Stockinette stitch with color stripes and Mickey Mouse Motif. Bands are Ribbed.

FINISHING: See General Instructions. Turn Sleeve bands to the right side and sew in place. Sew 1 edge of neckband to the inside and 1 to the outside of neckline.



PUNCH CARD ON PAGE 41

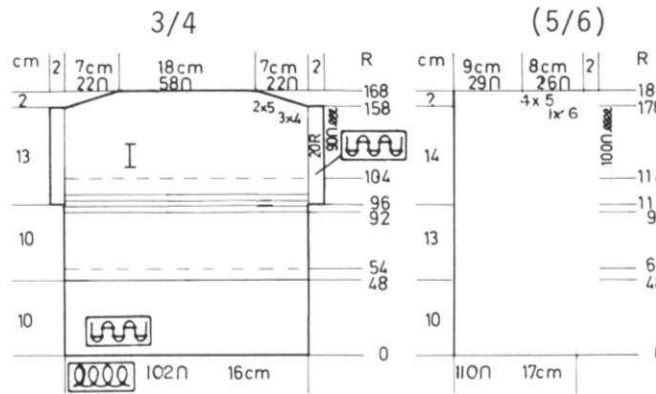

### ARMBANDS:

Sew shoulder seams, then pick up 90 (100) sts. and with color 1 work 20 rows K1, P1 Ribbing. Bind off.

### NECKBAND:

Cast on 110 sts. with color 2 and work 16 rows K1, P1 Ribbing. Remove onto contrast waste yarn.

### BACK: I

Cast on 102 (110) sts. with color 1 and work 48 rows K1, P1 Ribbing. Continue in Stockinette stitch with color 1 to Row 54 (62). Work the Mouse Pattern (norwegian technique) following the color changes as shown on the picture. When Motif is completed, work Stockinette stitch to Row 92 (98) with color 1. Work Color stripes in Stockinette stitch - 2 rows color 3, 2 rows color 1, 2 rows color 4, 2 rows color 1, 2 rows color 2. Work Stockinette stitch with color 1 to Row 104 (114). Reverse the Mouse Card and work the Motif with color changes as shown on the picture. Continue in Stockinette stitch with color 1. After Row 158 (178), SHAPE SHOULDER: ON EACH SIDE, bind off 4 sts. 3x, 5 sts. 2x. (6 sts. 1x, 5 sts. 4x). After Row 168 (188), bind off the remaining sts.

# KK 711

## BOY'S PULLOVER

SIZES: 8/10 (12) [14]  
 YARN: Crocus Crepe  
 GRAMS:  
 color 1 450 500 500  
 color 2 50 100 100  
 color 3 Few yards.  
 TENSION: 6 to 8  
 GAUGE: 14 sts. 19 rows = 5 cm (2")

Stockinette stitch with a color strip down the sides, across the arms and above the Ribbing of band. A single Motif is worked in the Norwegian Technique on the front section.

FINISHING: See General Instructions. Sew color strips in place then sew side seams and sew in sleeves.

PUNCH CARD ON PAGE 41

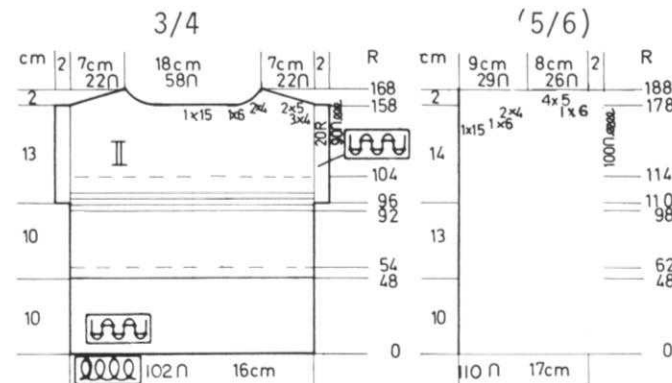

### FRONT: II

Work the front the same as the back to Row 158 (178). Put half the sts. on the left into holding position and complete the right side first. \*SHAPE SHOULDER AND NECK AT THE SAME TIME. SHAPE SHOULDER SAME AS THE BACK and ON NECK SIDE, bind off 15 sts. 1x, 6 sts. 1x, 4 sts. 2x, for both sizes. Bring the needles on the left into working position, knit 1 row to the left side, turn the Row Counter back to 158 (178) and complete the left half. Follow the instructions from \*.

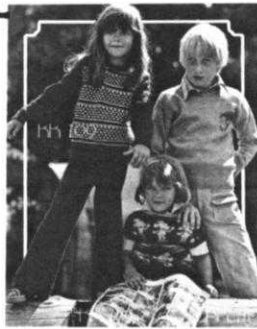

### PULLOVER BACK: II

Cast on 112 (118) [120] sts. with color 1 and work 28 rows K1, P1 Ribbing. Continue in Stockinette stitch, working 2 rows color 1, 12 rows color 2. ON EACH SIDE, REMOVE 9 sts. onto a stitch holder. ON EACH SIDE, cast on 1 st. (for seam) then continue in Stockinette stitch with color 1. Knit to Row 188 (198) [198]. Put half the sts. on the left into holding position and complete the right side first. \*SHAPE SHOULDER AND NECK AT THE SAME TIME. FOR SHOULDER, bind off 5 sts. 5x, (6 sts. 4x, 3 sts. 1x), [6 sts. 4x, 3 sts. 1x], FOR NECK: Bind off 10 (11) [12] sts. 1x, 4 sts. 3x. Bring the needles on the left into working position, knit 1 row to the left side, turn the Row Counter back to 188 (198) [198] and complete the left half. Follow the instructions from \*. Hang 9 sts. held on stitch holder back onto the machine. Add 1 st. on inner edge for seam. Put Counter at 42 then work Stockinette stitch with color 2 to Row 188 (198) [198]. Bind off. Repeat for other side.

PUNCH CARD ON PAGE 41

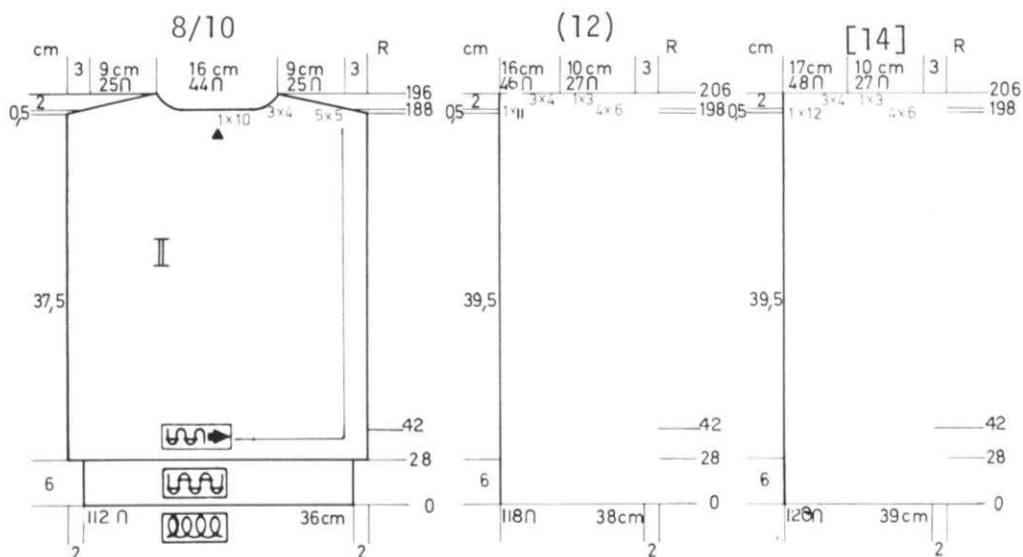

Continued

# KK 711

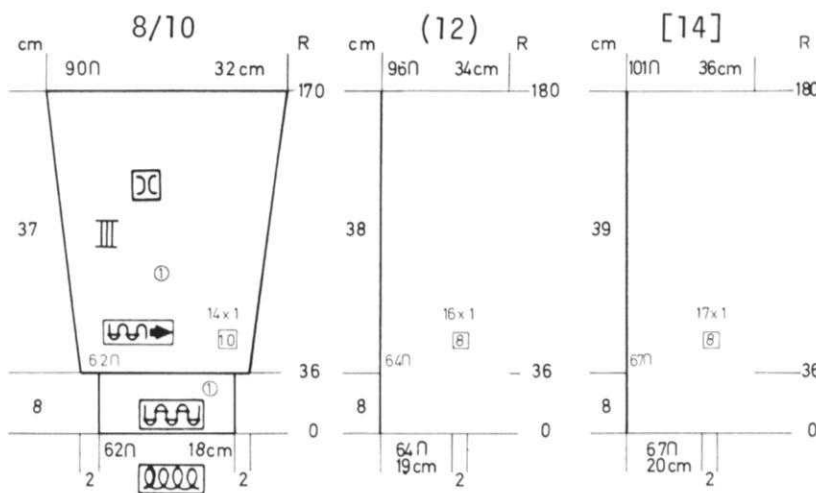

SLEEVES: III

Cast on 62 (64) [67] sts. with color 1 and work 36 rows K1, P1 Ribbing. Continue in Stockinette stitch. ON EACH SIDE, increase 1 st. every 10th row 14x. (every 8th row 16x). [every 8th row 17x]. After Row 170 (180) [180], bind off.

PULLOVER FRONT: I

Work the front the same as the back to Row 62. ON THE RIGHT, Work the Single Motif over the 13th to 36th stitches.

14 rows Colors 1 and 2  
2 rows color 1  
34 rows colors 1 and 3  
When Motif is completed, continue in Stockinette stitch with color 1 to Row 170 (178) [178].

Put half the sts. on the left into holding position and complete the right side first.

\*ON NECK SIDE, bind off 4 (5) [4] sts. 1x, then 3 sts. 2x, 2 sts. 3x, (3x) [4x] 1 st. 6x.

After Row 186 (196) [196], SHAPE SHOULDER same as the back. Bring the needles on the left into working position, knit 1 row to the left side, turn the Row Counter back to 170 (178) [178] and complete the left half. Follow the instructions from \*

Hang 9 sts. held on stitch holder back onto the machine. Add 1 st. on inner edge for seam. Put Counter at 42 and work Stockinette stitch with color 2 to Row 186 (196) [196]. Bind off. Repeat for other side.

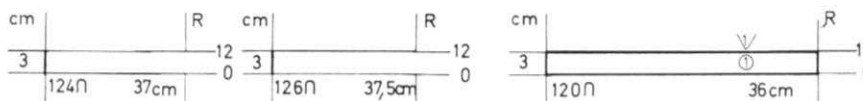
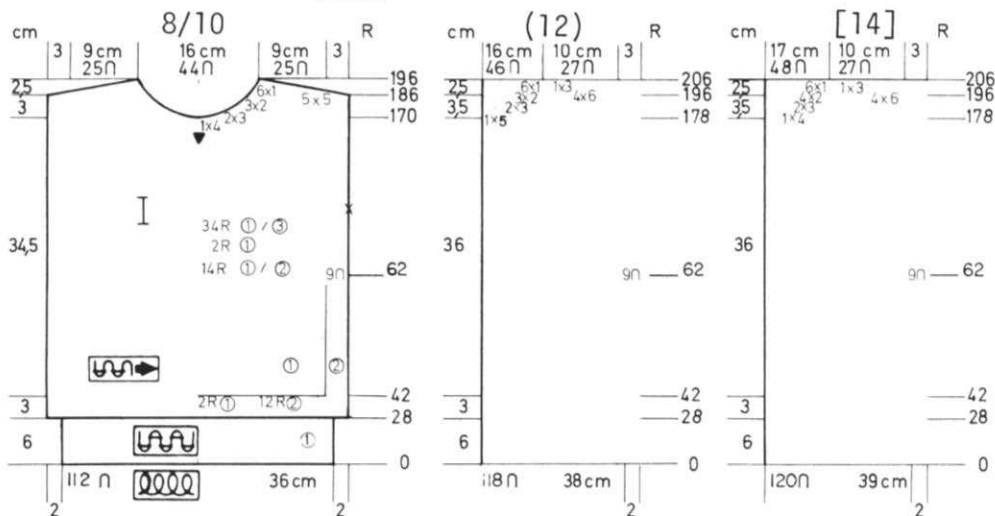

NECKBAND:

Cast on 120 (124) [126] sts. with color 1 and work 12 rows K1, P1 Ribbing. Remove on contrast waste yarn or you can bind off.

# KK 712

## BABY SACK & JACKET

SIZE: Infant to 6 months  
YARN: Amore  
GRAMS:  
color 1 300  
color 2 100  
color 3 200  
TENSION: 6 to 8  
GAUGE: 16 sts. 24 rows = 5 cm (2")

Stockinette stitch with color stripes for the Jacket. The Sack is Stockinette stitch with color stripes and a Tuck Pattern. The Straps, lower edge and top of Sack are K1, P1 Ribbing.

FINISHING: Sack: Crochet the two sections together with color 3. Sew straps on back, buttons on front. Jacket: Sew side and sleeve seams. Work single crochet around all edges, making 6 buttonholes on one front edge (right for girl-left for boy) on the 2nd row. With color 1, work 1 row shell stitch around sleeve and neck edges. Pull a cord through at neckline and on sleeves (see picture).



PUNCH CARD  
ON PAGE 41

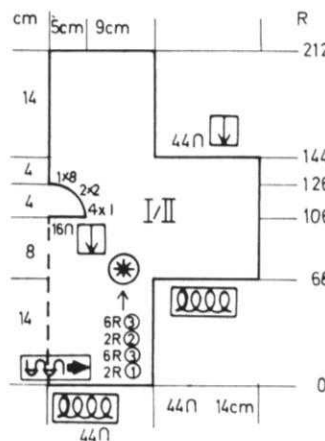

JACKET:

Cast on 88 sts. with color 1 and work Stockinette stitch with REPEATED color stripes as shown on the Chart.

After Row 68, ON EACH SIDE, cast on 44 sts. Knit to Row 106.

Bind off (or you can remove the sts. onto a stitch holder) the center 32 sts. Put the sts. on the left into holding position and complete the right side first.

\*ON NECK SIDE, bind off 1 st. 4x, 2 sts. 2x, 8 sts. 1x. After Row 144, ON ARM SIDE, bind off 44 sts.

Knit to Row 212 and bind off the remaining sts. Bring the needles on the left into working position, knit 1 row to the left side, turn the Row Counter back to 106 and complete the left half. Follow the instructions from \*.

STRAPS: Make 2

Cast on 31 sts. with color 1 and work K1, P1 Ribbing to Row 90. Make a BUTTONHOLE over the center 3 sts. then ON EACH SIDE, decrease 1 st. every 2nd row 12x. Bind off the remaining sts.

# KK 714

## BABY OVERALLS & PULLOVER

SIZE: 12 to 18 months  
 YARN: Amore  
 GRAMS:  
 color 1 150  
 color 2 50  
 color 3 150  
 color 4 50  
 TENSION: 6 to 8  
 GAUGE: Pat: 14 sts. 41 rows = 5 cm (2")  
 Stock: 16 sts. 24 rows = 5 cm (2")

The Pullover is Stockinette stitch with Cables down the front section. Bands are K1, P1 Ribbing. The Overalls are in a Tuck Pattern with color stripes as given. Punch your own Card or 830 machine owners use Card No. 1 in your original set. Push in BOTH Tuck Buttons. The Purl side of Pattern is the right side.

FINISHING: See General Instructions. Pullover: Work single crochet down back opening then sew in zipper. Overalls: Fold waistband to the wrong side and sew in place. Sew straps to Bib. Put elastic in at waist. Sew buttons on back.



## OVERALLS: IV

Cast on 70 sts. with color 1 and work in Pattern. Knit 16 rows color 1, 16 rows color 4, 16 rows color 3, 16 rows color 2. Continue with color 1.  
 After Row 150. ON EACH SIDE, increase 1 st. every 10th row 3x, every 5th row 7x. Put these needles into holding position (or you can remove them onto waste yarn). ON THE LEFT SIDE of machine, cast on 70 sts. and work the same as the first section.  
 After Row 216, cast on 4 sts. to the right of these sts, then bring the sts. from holding position into work (or hang the sts.) Break yarn in the center and attach at right. WATCH PATTERN. Continue over all the needles.  
 ON EACH SIDE, cast on 2 sts. After Row 382, work K1, P1 Ribbing to Row 396.  
 Remove all but 56 sts. on the RIGHT onto waste yarn and continue K1, P1 Ribbing to Row 410. Bind off. Put Counter at 396. Hang the next 10 sts. onto machine and work K1, P1 Ribbing with color 1 to Row 600. Make BUTTONHOLE over the center 4 sts. then knit to Row 608. Bind off.  
 Hang the next 56 sts. back onto machine and work in Pattern. Put Counter at 396. work the COLOR STRIPES as shown on the Chart to Row 498. then with color 1 work K1, P1 Ribbing to Row 508. Bind off.  
 Hang the next 10 sts. back onto machine and work strap the same as the first strap. Counter 396. Hang the last 56 sts. back onto machine. Counter at 396 and work K1, P1 Ribbing with color 1 to Row 410. Bind off.

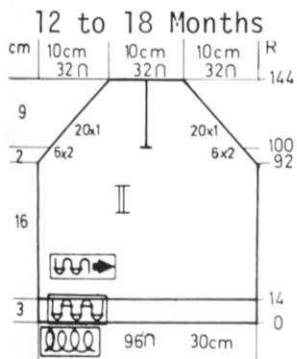

PULLOVER BACK: II

Cast on 96 sts. with color 3 and work 14 rows K1, P1 Ribbing. Continue in Stockinette stitch. Knit to Row 92.  
 SHAPE RAGLAN: ON EACH SIDE, decrease 2 sts. (full fashion decreases) every 2nd row 6x, then 1 st. 20x BUT AT THE SAME TIME, after Row 100, divide in the center, put the needles on the left into holding position and work the right side first.  
 \*After Row 144, Bind off the remaining sts.  
 Bring the needles on the left into working position, knit 1 row to the left side, turn the Row Counter back to 100 and complete the left half. Follow the instructions from \* continuing the raglan shaping.

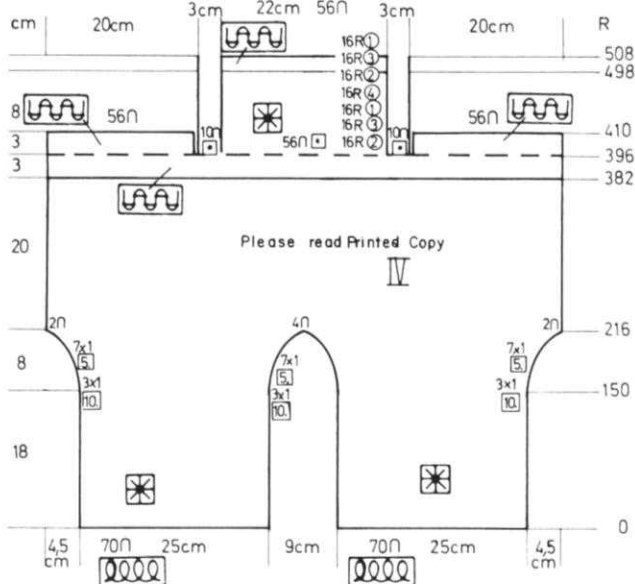

PULLOVER FRONT: I

Work the front the same as the back to Row 70.  
 Work the 3 sets of Cables over 4 sts. as shown on the Chart and REPEAT THE CABLES every 6th row, crossing 2 sts. with 2 sts.  
 AT THE SAME TIME, after Row 92, SHAPE RAGLAN same as the back. After Row 124, SHAPE NECK: Put half the sts. on the left into holding position and complete the right side first.  
 \*ON NECK SIDE, bind off 7 sts. 1x, 3 sts. 1x, 2 sts. 1x, 1 st. 4x.  
 After Row 144, bind off. Bring the needles on the left into working position, knit 1 row to the left side, turn the Row Counter back to 124 and complete the left half. Follow the instructions from \* and continuing the raglan shaping.

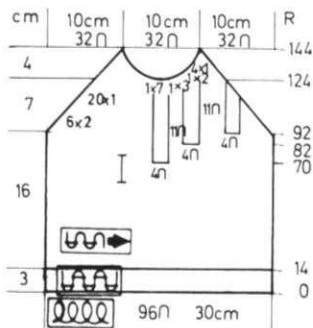

PULLOVER SLEEVES: III

Cast on 52 sts. with color 3 and work 20 rows K1, P1 Ribbing. Continue in Stockinette stitch. ON EACH SIDE, increase 1 st. every 8th row 12x.  
 After Row 116, SHAPE RAGLAN (full fashion). ON EACH SIDE, decrease 2 sts. every 2nd row 6x, then 1 st. 20x.  
 After Row 168, bind off the remaining sts.

NECKBAND: Sew in sleeves then pick up sts. around neckline and work 14 rows K1, P1 Ribbing. Bind off.

PUNCH CARD ON PAGE 40

## SACK: Make 2.

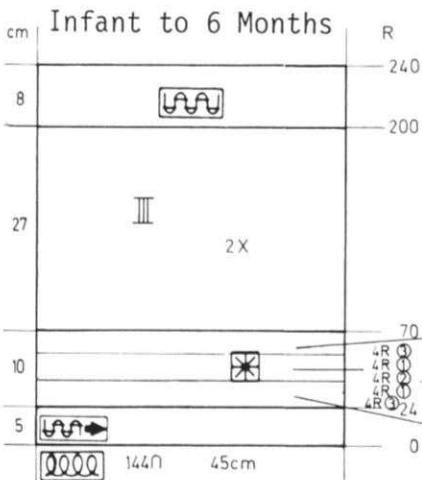

Cast on 144 sts. with color 1 and work 24 rows K1, P1 Ribbing. Transfer the ribber sts. to the main machine and work Stockinette with color stripes and Pattern as follows:  
 2 rows color 2  
 6 rows color 3  
 2 rows color 1  
 6 rows color 3  
 2 rows color 2  
 BEGIN TUCK PATTERN  
 4 rows color 3  
 4 rows color 1  
 4 rows color 2  
 4 rows color 1  
 4 rows color 3  
 REPEAT THE STOCKINETTE STITCH COLOR STRIPES 1x more.  
 Continue in Stockinette stitch with color 1.  
 After Row 200, Work K1, P1 Ribbing to Row 240 then bind off.

# KK 713

## BABY'S SACK & PULLOVER

SIZE: Infant to 6 months.  
 YARN: Amore  
 GRAMS: 300  
 TENSION: 6 to 8  
 GAUGE: 12 1/2 sts. 21 rows = 5 cm (2")

A Lace Pattern. Punch your own Card. Top of Sack and straps are ribbed.

FINISHING: Jacket: Sew sides and sleeve seams. Work 1 row single crochet around edges and sleeves then work \*5 double crochet in first st., 1 single crochet in next st., skip 1 stitch and REPEAT FROM \* around. Pull ribbon through at neckline and tie in bow (see picture). Sack: Single crochet sections together then work shell crochet same as on Pullover. Sew straps on front and buttons on back.



PUNCH CARD  
ON PAGE 42

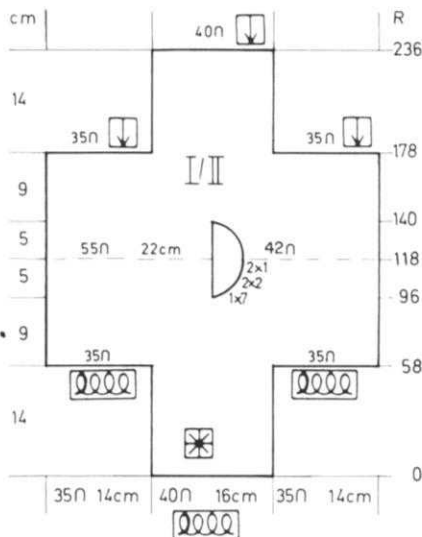

PULLOVER:

Cast on 40 sts. and work in Pattern. Knit to Row 58.  
 ON EACH SIDE, cast on 35 sts. Knit to Row 96. Divide in center. Put 55 sts. on the left into holding position and complete the right side first.  
 ON NECK SIDE, bind off 7 sts. 1x, 2 sts. 2x, 1 st. 2x. Knit to Row 131. ON NECK SIDE, cast on 1 st. 2x, 2 sts. 2x, 7 sts. 1x.  
 After Row 140, put these sts. into holding position. Bring the 55 sts. on the left into working position, put Row Counter at 96. Mark Row 118 for center back with a bit of contrast yarn then knit to Row 140. Break yarn and move the Slide to the right side. Bring all the needles back into working position and continue over all stitches in Pattern. (Be sure to watch pattern Row). After Row 178, ON EACH SIDE, bind off 35 sts. then knit to Row 236 and bind off the remaining sts.

SACK: Make 2

Cast on 113 sts. and work in Pattern to Row 176. Continue in K1, P1 Ribbing to Row 216, then bind off.

STRAPS: Make 2.

Cast on 31 sts. and work K1, P1 Ribbing to Row 90. Make BUTTONHOLE over the center 3 sts. then ON EACH SIDE, decrease 1 st. every 2nd row 12x. Bind off. Work Shell st. crochet on each side of straps as on Jacket.

# KK 715

## CHILD'S JACKET & PANTS

SIZES: 4/6 (7) [8/10]  
 YARN: Fortissima  
 GRAMS: color 1 300 300 350  
 color 2 200 250 300  
 TENSION: Jacket: Punch Pile = 5.1  
 Pants: Tuck = 6 to 8  
 GAUGE: Jacket: 15 sts. 25 rows = 5 cm (2")  
 Pants: 15 sts. 28 rows = 5 cm (2")

The Jacket shown was knitted in Punch Pile on a Studio machine. If you can get the stitch and row gauge using a Tuck Card, you can knit the Jacket. The pants are a Tuck Stitch. Punch your own Card. 830 machine owners, use Card No. 1 from your original set. The bands and collar of Jacket are Ribbed. You will need a Jacket type zipper.

FINISHING: See General Instructions. After sewing the shoulder together, Sew 1 edge of zipper to the right front, then sew other edge to left front (Ia). Turn garment over to the wrong side and sew edge of undersection on top of zipper tape that is attached to left front. Close the small opening that will be above the zipper. Pin, then sew collar from center of UNDER SECTION around and across the back neck then sew remaining section of collar onto the FRONT section of Jacket to the center front. (See Picture). Pants: Make hem at waist then pull elastic through casing.

JACKET WAISTBAND:

Cast on 180 (190) [196] sts. with color 1 and work 40 rows K1, P1 Ribbing. Remove onto waste yarn or you can bind off.

JACKET FRONT: I

Cast on 72 (75) [78] sts. with color 1 and work in Pattern. Knit to Row 89 (99) [99]. SHAPE ARMHOLE: Bind off 2 sts. 3x, 1 st. 3x. (2 sts. 3x, 1 st. 3x). [2 sts. 3x, 1 st. 4x]. Knit to Row 140 (152) [164]. Put all but 19 (20) [20] sts. on the RIGHT into holding position and complete the right side first. ON NECK SIDE, bind off 3 sts. 2x, 2 sts. 3x, 1 st. 7x (8x) [8x]. Bring the needles on the left into working position, knit 1 row in Pattern to the left side, turn the Row Counter back to 140 (152) [164]. ON NECK SIDE, bind off 3 sts. 2x, 2 sts. 3x, 1 st. 6x for all sizes BUT AT THE SAME TIME, after Row 157 (171) [187], SHAPE SHOULDER: Bind off 4 sts. 5x, 3 sts. 2x. (4 sts. 7x). [5 sts. 6x].

PUNCH CARD ON PAGE 40

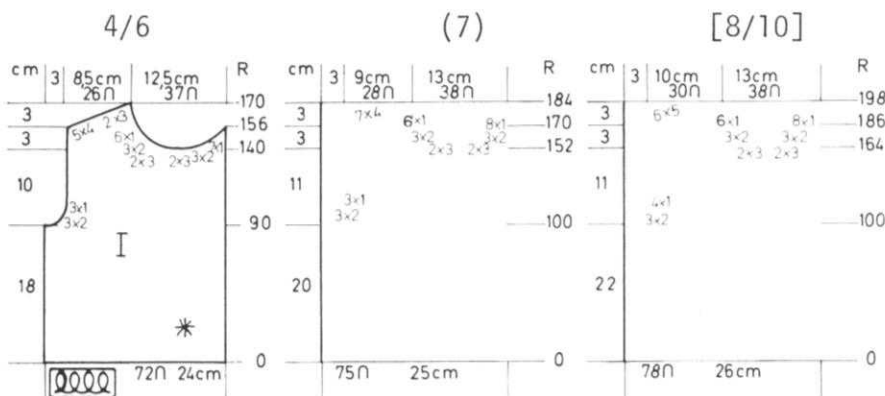

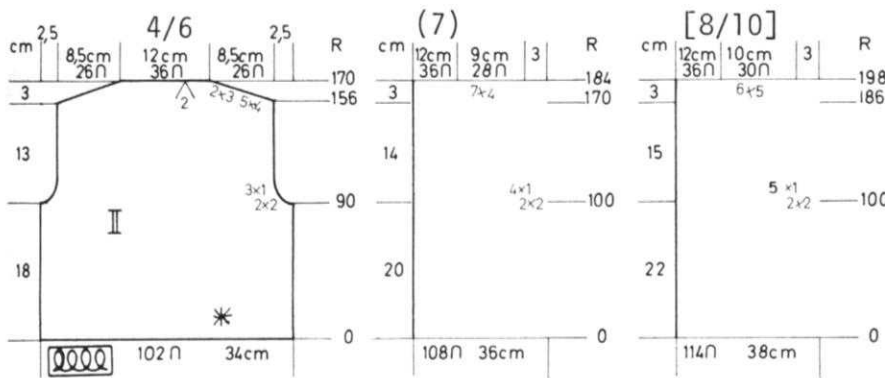

JACKET BACK: II

Cast on 102 (108) [114] sts. with color 1 and work in Pattern. Knit to Row 90 (100) [100]. SHAPE ARMHOLE: ON EACH SIDE, bind off 2 sts. 2x, 1 st. 3x. (2 sts. 2x, 1 st. 4x). [2 sts. 2x, 1 st. 5x]. Knit to Row 156 (170) [186]. SHAPE SHOULDER: ON EACH SIDE, bind off 4 sts. 5x, 3 sts. 2x. (4 sts. 7x). [5 sts. 6x]. After Row 170 (184) [198], bind off the remaining sts.

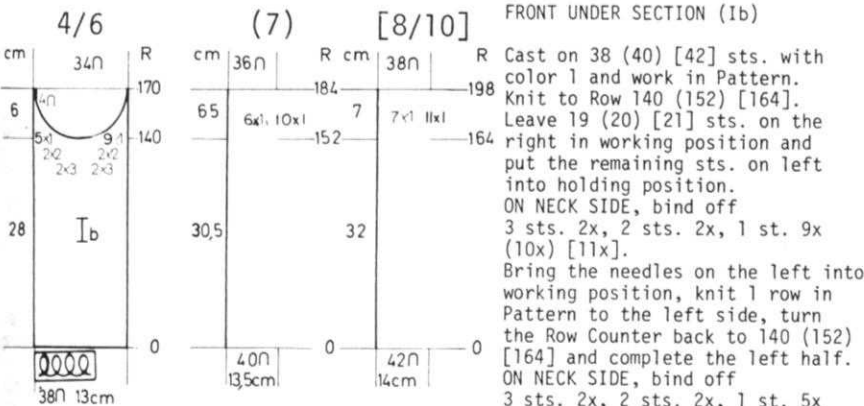

FRONT UNDER SECTION (Ib)

Cast on 38 (40) [42] sts. with color 1 and work in Pattern. Knit to Row 140 (152) [164]. Leave 19 (20) [21] sts. on the right in working position and put the remaining sts. on left into holding position. ON NECK SIDE, bind off 3 sts. 2x, 2 sts. 2x, 1 st. 9x (10x) [11x]. Bring the needles on the left into working position, knit 1 row in Pattern to the left side, turn the Row Counter back to 140 (152) [164] and complete the left half. ON NECK SIDE, bind off 3 sts. 2x, 2 sts. 2x, 1 st. 5x (6x) [7x].

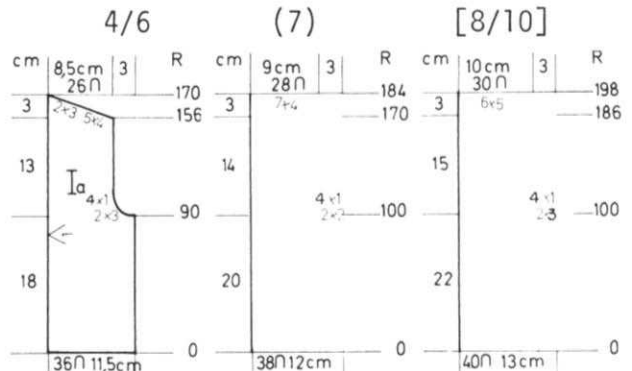

JACKET LEFT FRONT: (Ia)

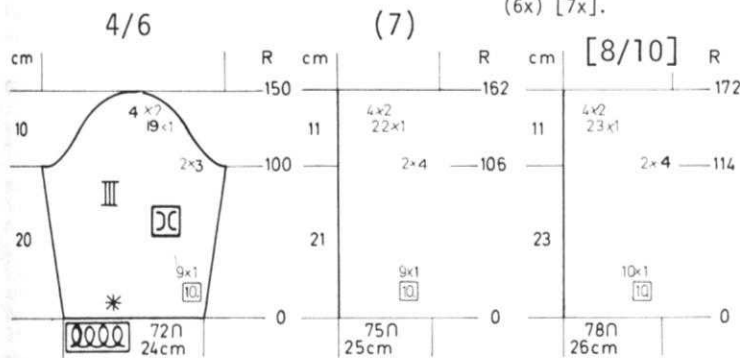

JACKET SLEEVES: III

Cast on 72 (75) [78] sts. with color 1 and work in Pattern. ON EACH SIDE, increase 1 st. every 10th row 9x (9x) [10x]. After Row 100 (106) [114], SHAPE CAP: ON EACH SIDE, bind off 3 sts. 2x, 1 st. 19x, 2 sts. 4x. (4 sts. 2x, 1 st. 22x, 2 sts. 4x). [4 sts. 2x, 1 st. 23x, 2 sts. 4x]. After Row 150 (162) [172], bind off the remaining sts.

Cast on 36 (38) [40] sts. with color 1 and work in Pattern. SHAPE ARMHOLE: Bind off 3 sts. 2x, 1 st. 4x for all sizes. Knit to Row 156 (170) [186]. SHAPE SHOULDER: Bind off 4 sts. 5x, 3 sts. 2x. (4 sts. 7x). [5 sts. 6x].

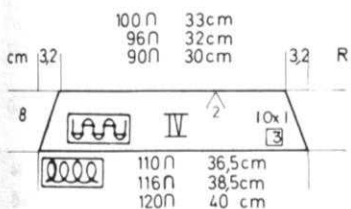

JACKET COLLAR: IV

Cast on 110 (116) [120] sts. with color 1 and work K1, P1 Ribbing. ON EACH SIDE, decrease 1 st. every 3rd row 10x. After Row 30 (34) [34], bind off.

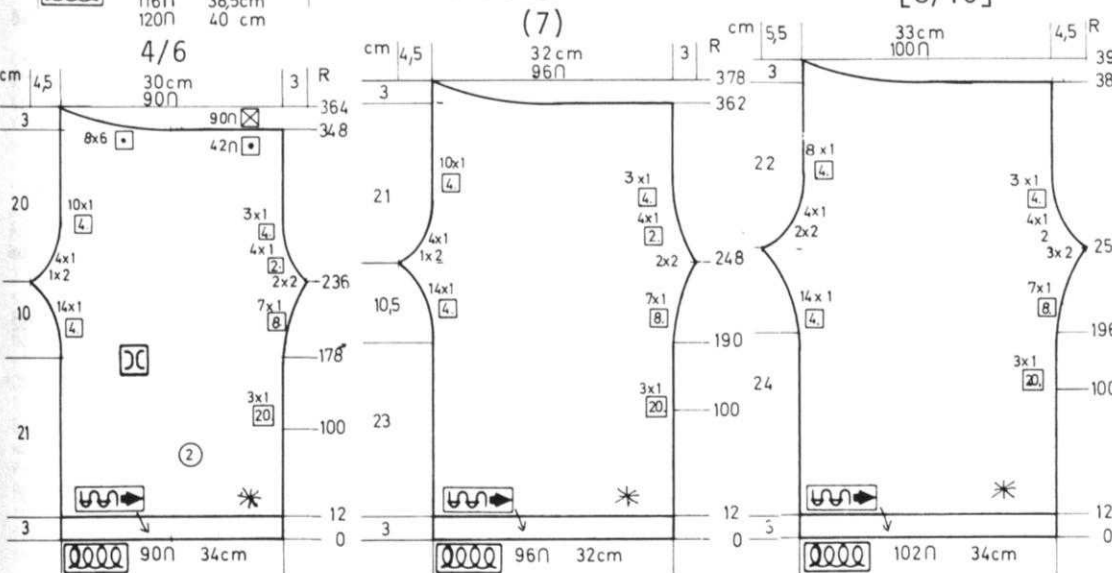

PANTS: Make 1, reverse 1.

Cast on 90 (96) [102] sts. with color 2 and work in Tuck Stitch Pattern. After Row 100, ON EACH SIDE, increase 1 st. every 20th row 3x for all sizes. After Row 178 (190) [196], Please work the different decreases ON EACH SIDE as shown on the Chart for the size you need. After Row 347 (361) [381], ON OPPOSITE SIDE OF SLIDE, put 42 sts. into holding position, Knit 1 row to the right (be sure to wrap yarn around inside needle in holding position) then ON OPPOSITE SIDE OF SLIDE, put into holding position 6 sts. 8x. After Row 363 (377) [397], put all the needles opposite slide into working position, knit 1 row, then bring all the remaining needles into working position, knit 1 row over all the needles and bind off loosely.

# KK 716

## GIRL'S JACKET & PANTS

**SIZES:** 10 (12) [14]  
**YARN:** Amore  
**GRAMS: JACKET**  
 color 1 150 200 200  
 color 2 150 200 200  
 color 3 150 200 200  
**GRAMS: PANTS**  
 color 1 300 300 350  
**TENSION:** 7 to 9  
**GAUGE:** Weaving -13 sts. 17 rows = 5 cm  
 Stock: 12 1/2 sts. 21 rows = 5 cm (2")



PUNCH CARD  
ON PAGE 40

The Jacket is Stockinette with color stripes as shown on the Chart. The Pants are a Weaving Pattern. Punch your own Card. 830 machine owners use Card No. 1 of your original set. Worn on the Purl side.

**FINISHING:** See General Instructions. Finish Buttonholes and sew on Buttons. Sew Pockets in place. Pull elastic through casing at waistline of pants.

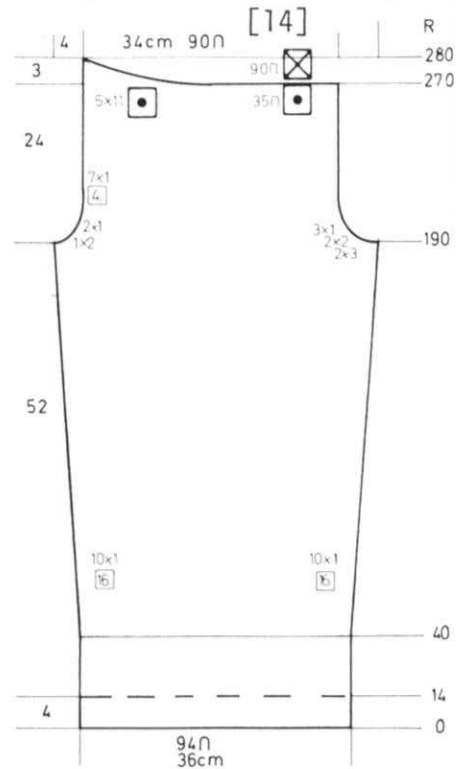
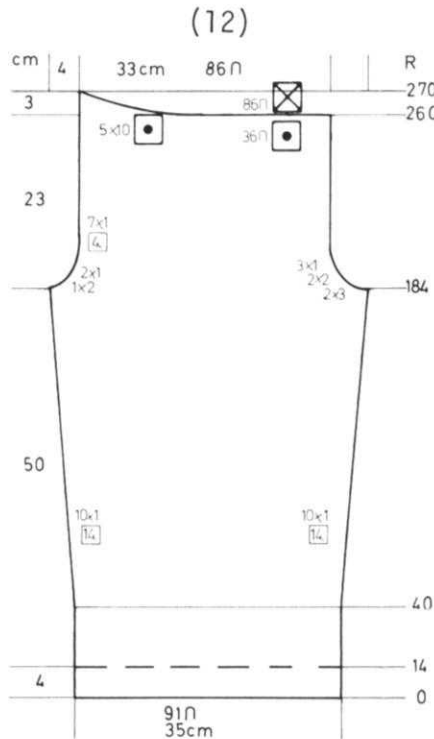
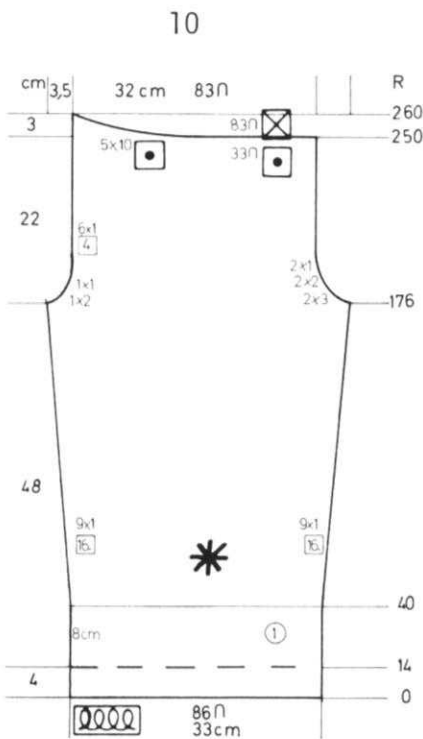
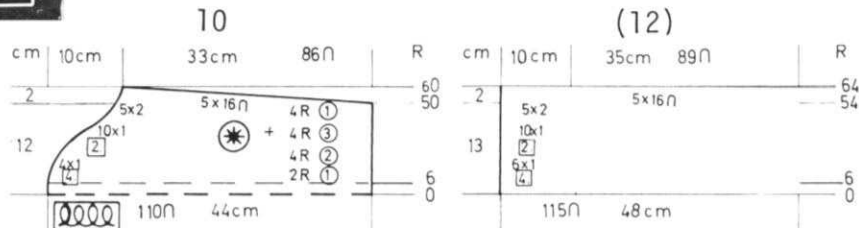
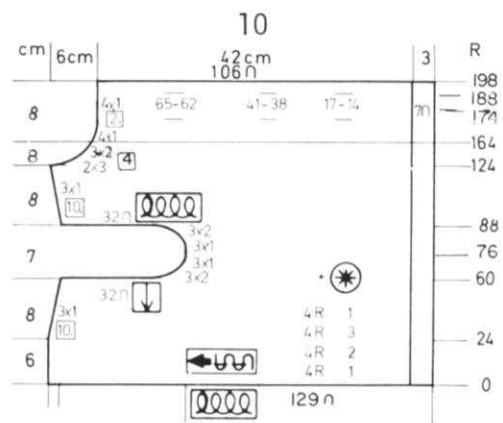

# KK 717

## BOY'S PULLOVER

**SIZE** 10/12)  
**YARN:** Fortissima  
**GRAMS:** 350  
**TENSION:**  
 Stock: 5 to 6.  
 PAT: 8 to 9  
**GAUGE:**  
 Stock: 14 sts. 17 rows = 5 cm (2")  
 Pat: 12 sts. 26 rows = 5 cm (2")



The Front and back are in a Tuck Stitch. Punch your own Card and push in BOTH Your Buttons. the sleeves are Stockinette stitch with bands in K1, P1 Ribbing. The purl side of Pattern is the right side with the knit side for the sleeves.

**FINISHING:** See General Instructions.

PUNCH CARD ON PAGE 42

### NECKBAND:

Sew 1 shoulder seam, then pick up the sts. around the neckline and work 12 rows K1, P1 Ribbing. Bind off.

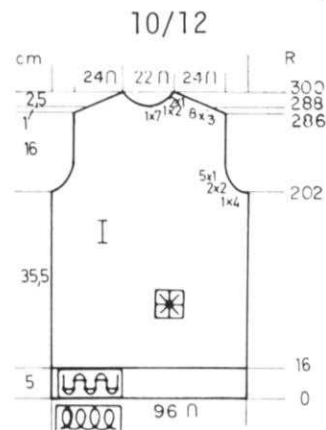

(12)

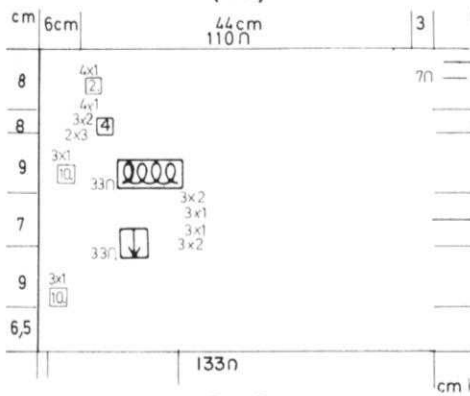

[14]

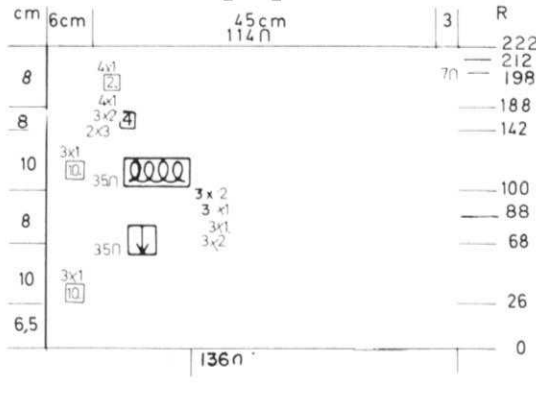

JACKET BACK & FRONT:

With contrast waste yarn, cast on 129 (133) [136] sts. Knit 8 to 10 Rows. Change to garment yarn and put Counter at 0. Continue in Stockinette stitch with color stripes as shown on the Chart. After Row 24 (26) [26], ON OPPOSITE SIDE OF SLIDE, decrease 1 st. every 10th row 3x. After Row 59 (65) [67], SHAPE ARMHOLE: Bind off 32 (33) [35] sts. and every 2nd row, bind off 2 sts. 3x. At Row 76 (82) [88] Cast on 1 st. 3x, 2 sts. 3x. After Row 89 (95) [101], cast on 32 (33) [35] sts. ON SHOULDER SIDE, increase 1 st. every 10th row 3x. After Row 125 (135) [143], SHAPE NECK: ON EVERY 4th ROW, bind off 3 sts. 2x, 2 sts. 3x, 1 st. 4x, then EVERY 2nd ROW, bind off 1 st. 4x. Knit to Row 174 (186) [198]. MAKE BUTTONHOLES over needles 14 to 17, 38 to 41, 62 to 65 counting from the right edge. Make BUTTONHOLES over the same needles after Row 188 (200) [212]. Knit to Row 198 (210) [222]. Bind off. Hang the open sts. of the center back onto the machine and remove waste yarn. Follow the instructions from the beginning except that the shapings will now be on the right side instead of left and omit the buttonholes in band.

[14]



SLEEVES:

With contrast waste yarn, cast on 110 (115) [120] sts. Knit 8 to 10 rows, change to garment yarn and Put Counter at 0. Work Stockinette stitch with REPEATED color stripes as shown on the Chart. ON THE LEFT, decrease 1 st. every 4th row 4x, every 2nd row 10x, then bind off 2 sts. 5x. (every 4th row 6x, every 2nd row 10x, then bind off 2 sts. 5x). [every 4th row 6x, every 2nd row 10x, then bind off 2 sts. 6x]. After Row 50 (54) [58], bind off 16 sts. 5x for all sizes. Hang the open sts. held on waste yarn back onto the machine and repeat for second half of sleeve but the shapings will be on the right instead of left.

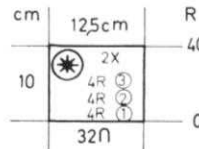

POCKET: Make 2.

Cast on 32 sts. with color 1 and work Stockinette stitch with color stripes as shown on the Chart. After Row 40, bind off.

PANTS: Make 1, reverse 1.

Cast on 86 (91) [94] sts. with color 1 and work the Weaving Pattern. After Row 40, ON EACH SIDE, increase 1 st. every 16th row 9x. (every 14th row 10x). [every 16th row 10x]. After Row 176 (184) [190], Please follow the different shapings as shown on the Chart for each side in the size you need. After Row 249 (259) [269], ON OPPOSITE SIDE OF SLIDE, put 33 (36) [35] sts. into holding position, then put 10 (10) [11] sts. 5x into holding position. Bring all the needles back into working position, knit 1 loose row then bind off loosely. Make the 2nd section with reverse shapings.

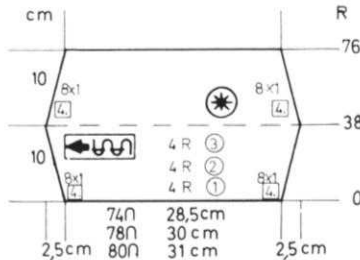

COLLAR:

Cast on 74 (78) [80] sts. with color 1 and work Stockinette stitch with color stripes as shown on the Chart. ON EACH SIDE, on every 4th row, increase 1 st. 8x. After Row 38, ON EACH SIDE, decrease 1 st. every 4th row 8x. After Row 76, bind off.

PULLOVER BACK: I

Cast on 96 sts. and work 16 rows K1, P1 Ribbing. Continue in Pattern. Knit to Row 202. SHAPE ARMHOLE: ON EACH SIDE, bind off 4 sts. 1x, 2 sts. 2x, 1 st. 5x. Knit to Row 286. SHAPE SHOULDER and watch for NECK SHAPING. ON EACH SIDE, for SHOULDER, bind off 3 sts. 8x and AT THE SAME TIME, after Row 288, SHAPE NECK: Put half the sts. on the left into holding position and complete the right side first. \*ON NECK SIDE, bind off 7 sts. 1x, 2 sts. 1x, 1 st. 2x. Bring the needles on the left into working position, knit 1 row in Pattern to the left side, turn the Row Counter back to 288 and complete the left half. Follow the instructions from \* and don't forget to complete the shoulder shaping.

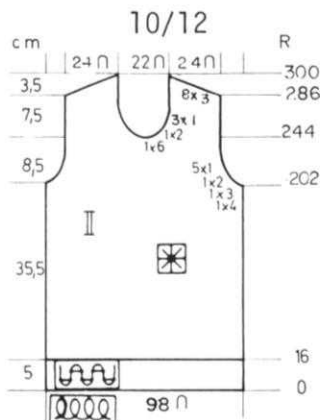

PULLOVER FRONT: I

Cast on 98 sts. and work 16 rows K1, P1 Ribbing. Continue in Pattern. Knit to Row 202. SHAPE ARMHOLE: ON EACH SIDE, bind off 4 sts. 1x, 3 sts. 1x, 2 sts. 1x, 1 st. 5x. Knit to Row 244. Put half the sts. on the left into holding position and complete the right side first. \*ON NECK SIDE, bind off 6 sts. 1x, 2 sts. 1x, 1 st. 3x, and after Row 286, SHAPE SHOULDER same as the back. Bring the needles on the left into working position, knit 1 row in Pattern to the left side, turn the Row Counter back to 244 and complete the left half. Follow the instructions from \*.

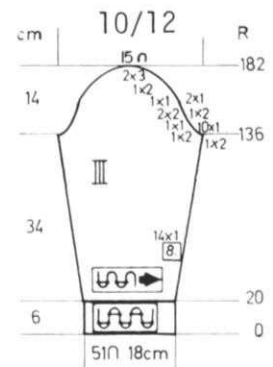

SLEEVES: III

Cast on 51 sts. and work 20 rows K1, P1 Ribbing. Continue in Stockinette stitch. ON EACH SIDE, increase 1 st. every 8th row 14x. After Row 136, SHAPE CAP: ON EACH SIDE, bind off 2 sts. 1x, 1 st. 10x, 2 sts. 1x, 1 st. 2x, 2 sts. 1x, 1 st. 1x, 2 sts. 2x, 1 st. 1x, 2 sts. 1x, 3 sts. 2x. After Row 182, bind off the remaining sts.

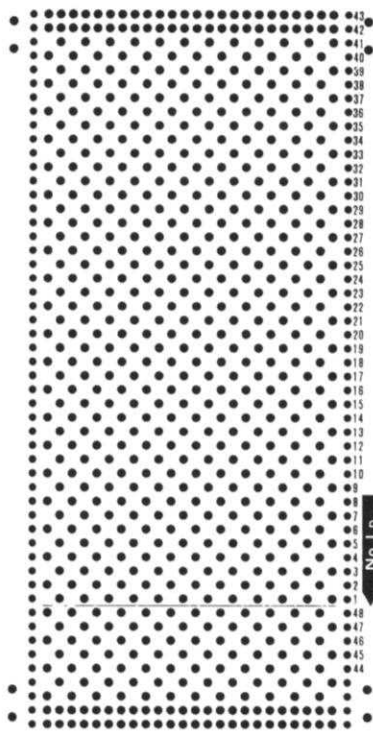

HP 692 - DK 693  
 DK 695 - HP 699  
 KK 708 - KK 714  
 KK 715 - KK 716

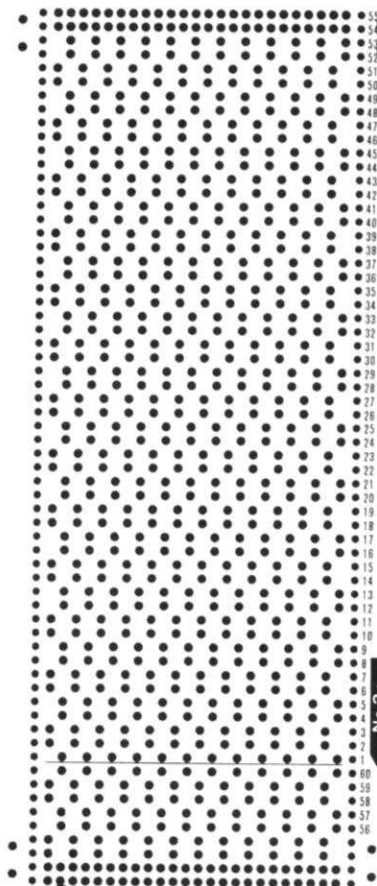

DK 694  
 DK 698

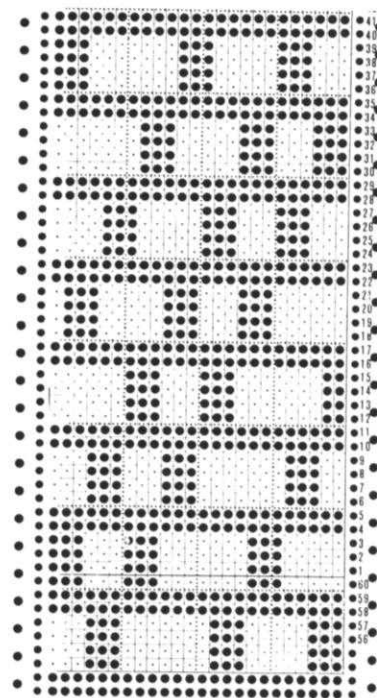

DK 697

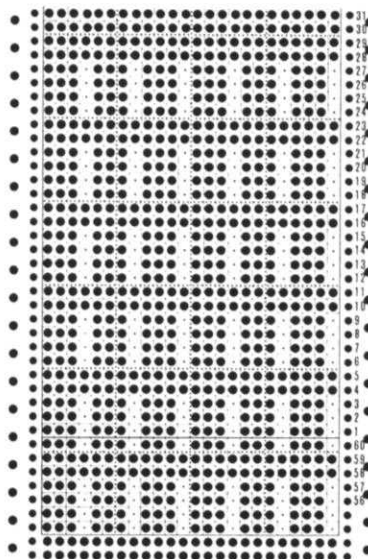

DK 702

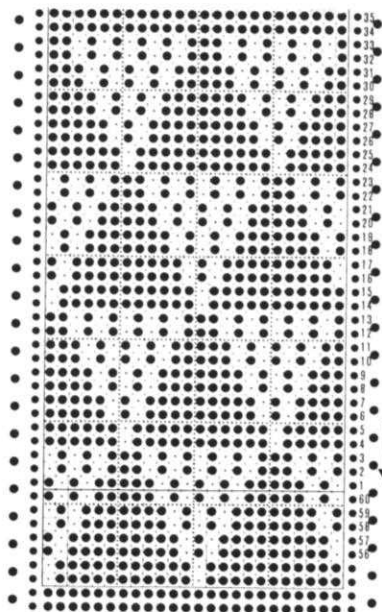

DK 703

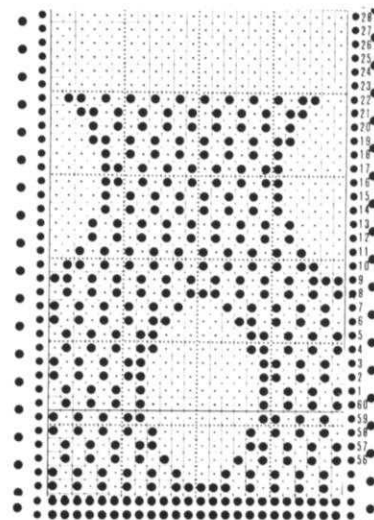

DK 704



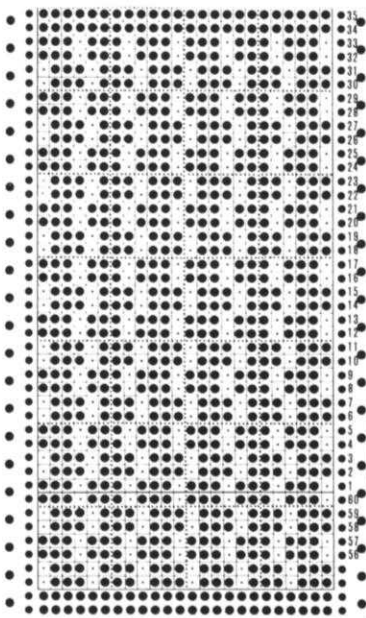

HP 705

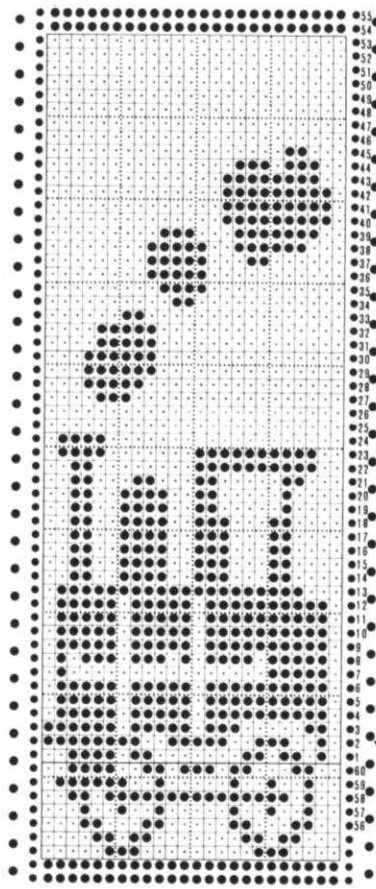

KK 706

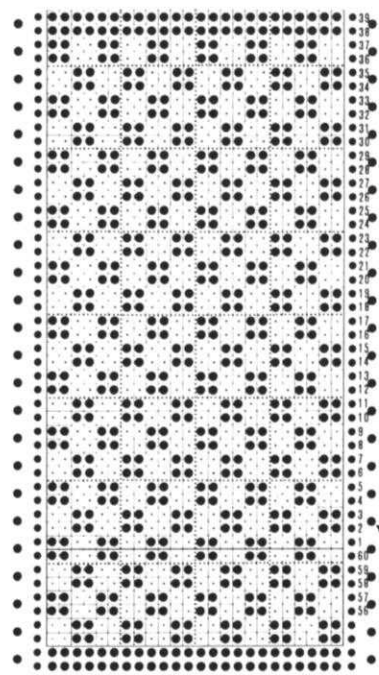

DK 701 - KK 706

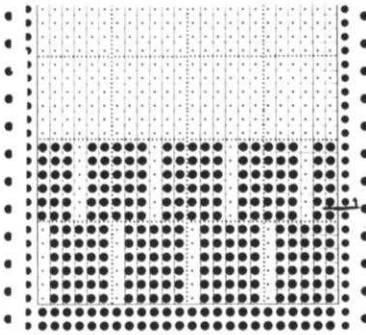

KK 707

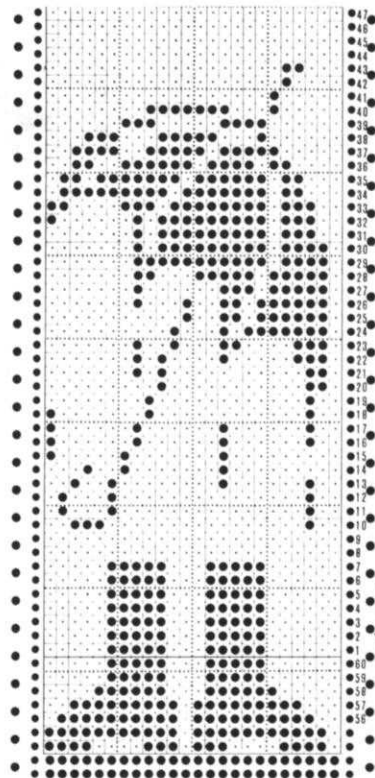

KK 711

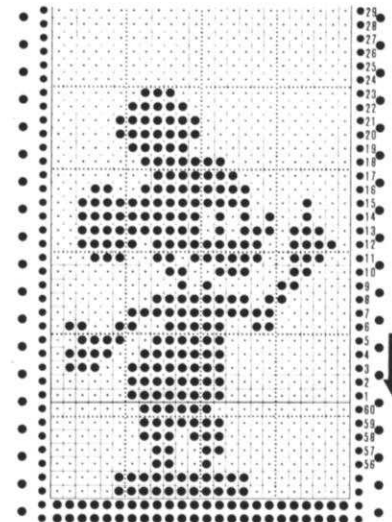

KK 710

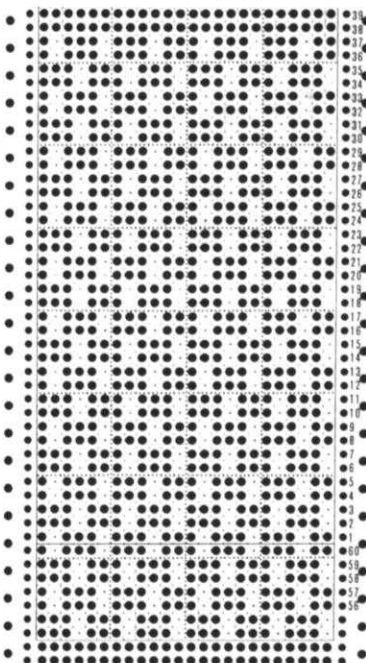

KK 709

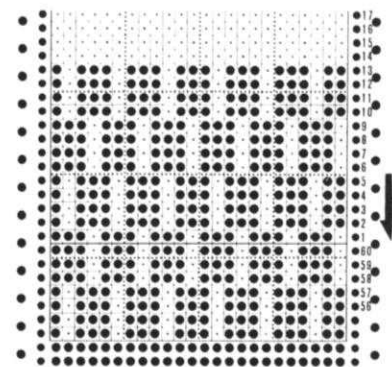

KK 712

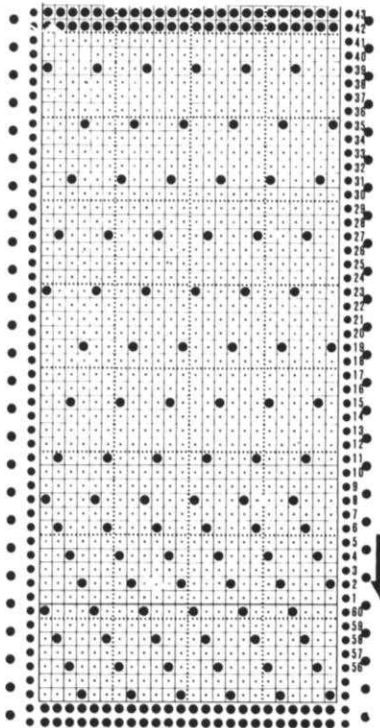

KK 713

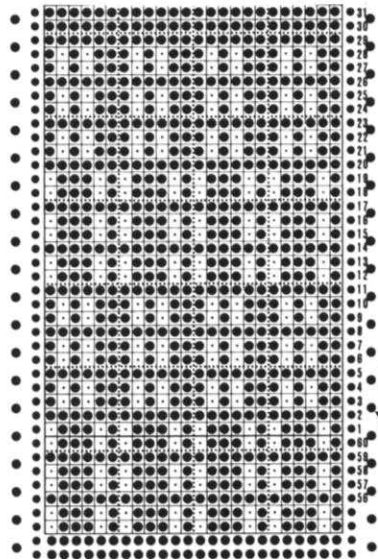

KK 717

**knitking announces their**

# SEMINAR

**and open house**

**1979**



On the premises at 1128 Crenshaw Blvd., Los Angeles, Calif. 90019... Commencing Monday, October 8th and running through Saturday, the 13th. During the five weekdays the Seminar will operate from 10 a.m. until 4 p.m., and on Saturday from 10 a.m. until 1 p.m.

Admission will be FREE - Coffee and Doughnuts will be available at 9:30 a.m. daily. Plan to be with us and to meet the knitting experts at KNITKING. Classes and Lectures on all phases of machine knitting - Measuring - Charting, etc., will continue throughout every day.



# KNITTING NEWS

## PRACTICAL KNITTING HINTS

### USING LACE PUNCH CARDS

We have had some requests to place markings on the Lace Punch Cards given in KNITTING MAGAZINE, to show the movements of the Lace Carriage and the Knit Carriage (Slide).

The following Instructions for using the Lace Cards which are punched for use with the KH 830 or 820 machines only apply to these machines where the Lace Carriage remains on the machine at all times... it never needs to be lifted and placed to the opposite side of the machine.

If you have worked with any of the Lace Cards in the set which comes with your machine, no doubt you have discovered some interesting facts - the main fact being that before you can knit 2 rows (or more if called for), the Lace Carriage MUST BE ON THE LEFT SIDE and ALL NEEDLES in working position. As long as the Lace Carriage sets needles into Pattern for transferring stitches, you continue to move the Lace Carriage back and forth until the last transfer of stitches and if the Lace Carriage is on the right, there is one more movement to bring the Lace Carriage back to the left. Nothing happens with this last movement, the needles remain just as they are and you can now knit 2 rows with the Knit Carriage.

To help our beginners especially, we will take a look at the Lace Card for KK 713, a Baby Sack and Pullover in this issue of KNITTING MAGAZINE. It is a simple zig-zag eyelet design and you always knit 2 rows after the transfers and when the Lace Carriage is on the left. We will follow this Card through and see what happens.

Cast on 60 sts. Knit 2 rows (always knit at least 2 rows before beginning a lace pattern). Hang weights on the machine when knitting lace as this prevents dropped stitches. Put in the Punch Card. Roll the Card to the No. 1 line and set the Card on STOP. Move the Lace Carriage from left to right. Needles have set into Pattern. Put the Card on GO. Move the Lace Carriage from right to left. The stitches have been transferred and all needles are in working position. Knit 2 rows with the Knit Carriage. Move the Lace Carriage from left to right - the needles set, move the Lace Carriage from right to left. The stitches transfer and the Lace Carriage is again on the left so knit 2 rows with the Knit Carriage. Continue in this manner until the Card shows 16. You have 8 holes in your knitting, all moving to the left. Be sure to knit the 2 rows after the last transfer.

Now the Zig-Zag Pattern must move to the RIGHT. Move the Lace Carriage to the right - nothing happens. Move it to the left. The needles set into pattern. Move the Lace Carriage to the right, the stitches transfer and all needles are in working position - BUT the Lace Carriage is on the right side, so move it back to the left, then knit 2 rows. As you can see, there has to be an EMPTY row so the Lace Carriage can be brought back to the left side. Move the Carriage to the right, nothing happens, move it to the left and the needles set, move it to the right and the stitches transfer, move it back to the left then knit 2 rows.

Continue in this way until the Card shows 60 and you have knitted the 2 rows. You will have 8 holes going to the RIGHT and the pattern now will zig zag to the left. Move the Lace Carriage to the right, the Card shows 1 and the needles are set. Move the Lace Carriage to the left and the stitches transfer to the left. You are now REPEATING THE CARD.

This is the method for working all Lace Cards for the KH 830 or 820 machines. Sometimes you will move the Lace Carriage MANY TIMES before all the needles are back in working position and the Lace Carriage is on the left side. We are giving you only an example for a simple Lace Card.

### DK 670 - WOMAN'S JACKET & SKIRT

We apologize for the omission of the Skirt for DK 670 in our last issue of KNITTING MAGAZINE. The Instructions are printed below with the correct amounts of yarn needed for both the Jacket and Skirt.

SIZES:	8/10	(12/14)	[16]
YARN:	Micaela		
GRAMS:	1100	1150	1200
TENSION:	8.1 for Jacket		
	5.2 for Skirt		
GAUGE: - JACKET:	22 sts. 18 rows = 5 cm (2")		
SKIRT:	14 sts. 22 rows = 5 cm (2")		

SKIRT: - Worn on the Purl side.

With contrast waste yarn, cast on 200 sts. Knit 8 to 10 rows ending with Slide on the right side.

Change to garment yarn and put Counter at 0.

\*With a single strand of yarn, knit 4 rows. Slide on right. Work SHORT ROWS: ON OPPOSITE SIDE OF SLIDE, put into holding position, 12 sts. Knit 2 rows with SINGLE strand of yarn and be sure to wrap the yarn around the inside needle in holding position.

Knit 2 rows with DOUBLE strand of yarn (be sure to wrap yarn again).

Bring all the needles back into working position and REPEAT from \* 73 x (77x) [81x] more. Row 592 (624) [656].

Remove the sts. onto contrast waste yarn.

Weave the open sts. together then remove the waste yarn. Fold waistband in half to the wrong side and sew in place. Single crochet around lower edge of skirt or you can make a hem if you prefer.

### KNITTING SEMINAR AND OPEN HOUSE

Make plans now to be with us for our big annual event. We are planning it this year to run from Monday, October 8th through Saturday, October 13th. As usual, admission will be FREE with coffee and doughnuts on the house... There will be a team of knitting experts demonstrating teaching and lecturing with classes running throughout every day...



If you intend being with us and would like to have classes on any special phases of machine knitting, drop us a line ahead of time and we will do our best to include them on our program.

DISCOUNTED KITS FOR THIS ISSUE

Here are the Yarn Kits available for this issue of KNITTING MAGAZINE. The Kits are available at special discounts to our subscribers and the prices are only good until the next issue of the magazine.

HP 692 - Yarn: Crocus Crepe			
SIZES:	36	(38)	[40]
Regular Price	\$63.00	\$63.00	\$69.30
Sale Price	50.40	50.40	55.44
Shipping Costs	1.85	1.85	3.15
DK 693 - Yarn: Crocus Crepe			
SIZES:	8	(10)	[12]
Regular Price	\$75.60	\$81.90	\$88.20
Sale Price	60.48	65.52	70.56
Shipping Costs	3.15	3.15	3.15
DK 694 - Yarn: Crocus Crepe			
SIZES:	8/10	(12)	[14]
Regular Price	\$78.75	\$85.05	\$91.35
Sale Price	63.00	68.04	73.08
Shipping Costs	3.15	3.15	3.15
DK 695 - Yarn: Fortissima & Amore			
SIZES:	8/10	(12)	[14]
Regular Price	\$31.35	\$40.08	\$42.66
Sale Price	25.08	32.07	38.28
Shipping Costs	1.85	1.85	1.85
DK 696 - Yarn: Crocus Crepe (Angora not included in Kit)			
SIZES:	8/10	(12)	[14]
Regular Price	\$44.10	\$47.25	
Sale Price	35.28	37.80	
Shipping Costs	1.85	1.85	
Yarn for embroidery as well as Angora not included in Kit.			
DK 697 - Yarn:			
SIZES:	8/10	(12)	[14]
Regular Price	\$59.15	\$59.15	\$66.20
Sale Price	51.16	51.16	56.80
Shipping Costs	3.35	3.35	3.35
DK 698 - Yarn: Vienna			
SIZES:	8	(12)	[14]
Regular Price	\$44.65	\$44.65	\$49.35
Sale Price	35.72	35.72	39.48
Shipping Costs	1.85	1.85	3.15
HP 699 - Yarn: Crocus Crepe			
SIZES:	36	(38)	[40]
Regular Price	\$44.10	\$44.10	\$47.25
Sale Price	35.28	35.28	37.80
Shipping Costs	1.85	1.85	1.85
DK 700 - Yarn: Vienna			
SIZES:	10/12	(14/16)	
Regular Price	\$39.95	\$42.30	
Sale Price	31.96	33.84	
Shipping Costs	1.85	1.85	
DK 701 - Yarn: - No Kit Available			
DK 702 - Yarn: Micaela			
SIZE: - One Size for Shawl			
Regular Price	\$22.90		
Sale Price	18.32		
Shipping Costs	1.85		
DK 703 - Yarn: Vienna			
SIZES:	8	(10)	[12]
Regular Price	\$42.30	\$42.30	\$44.65
Sale Price	33.84	33.84	35.72
Shipping Costs	1.85	1.85	1.85
DK 704 - Yarn: Crocus Crepe			
SIZES:	7/8	(10)	
Regular Price	\$50.40	\$53.55	
Sale Price	40.32	42.84	
Shipping Costs	1.85	1.85	

HP 705 - Yarn: Crocus Crepe			
SIZES:	38/40	(42/44)	[46/48]
Regular Price	\$56.70	\$59.85	\$63.00
Sale Price	45.36	47.88	50.40
Shipping Costs	1.85	1.85	1.85
KK 706 - Yarn: Fortissima			
SIZES:	3/4	(5/6)	[7/8]
Regular Price	\$18.06	\$18.06	\$20.64
Sale Price	14.45	14.45	16.51
Shipping Costs	1.85	1.85	1.85
KK 707 - Yarn: Euro Sport			
SIZES:	6	(7)	[8]
Regular Price	\$15.75	\$15.75	\$17.50
Sale Price	12.60	12.60	14.00
Shipping Costs	1.85	1.85	1.85
KK 708 - Yarn: Crocus Crepe			
SIZES:	7/8	(10)	[12]
Regular Price	\$31.50	\$34.65	\$37.80
Sale Price	25.20	27.72	30.24
Shipping Costs	1.85	1.85	1.85
KK 709 - Yarn: Fortissima			
SIZES:	5/6	(7/8)	
Regular Price	\$25.80	\$28.38	
Sale Price	20.64	22.70	
Shipping Costs	1.85	1.85	
KK 710 - Yarn: Amore			
SIZES:	3/4	(5/6)	
Regular Price	\$ 8.20	\$10.25	
Sale Price	6.56	8.20	
Shipping Costs	1.85	1.85	
KK 711 - Yarn: Crocus Crepe			
SIZES:	8/10	(12)	[14]
Regular Price	\$31.50	\$37.80	\$37.80
Sale Price	25.20	30.24	30.24
Shipping Costs	1.85	1.85	1.85
KK 712 - Yarn: Amore			
SIZE:	Infant		
Regular Price	\$24.60		
Sale Price	19.68		
Shipping Costs	1.85		
KK 713 - Yarn: Amore			
SIZE:	Infant to 6 Months.		
Regular Price	\$12.30		
Sale Price	9.84		
Shipping Costs	1.85		
KK 714 - Yarn: Amore			
SIZE:	12 to 18 Months		
Regular Price	\$16.40		
Sale Price	13.12		
Shipping Costs	1.85		
KK 715 - Yarn: Fortissima			
SIZES:	4/6	(7)	[8/10]
Regular Price	\$25.80	\$28.38	\$33.54
Sale Price	20.64	22.70	26.83
Shipping Costs	1.85	1.85	1.85
KK 716 - Yarn: Amore			
SIZES:	10	(12)	[14]
Regular Price	\$30.75	\$36.90	\$38.95
Sale Price	24.60	29.52	31.16
Shipping Costs	1.85	1.85	1.85
KK 717 - Yarn: Fortissima			
SIZE:	10/12		
Regular Price	\$18.06		
Sale Price	14.45		
Shipping Costs	1.85		



**Your Knitter needs  
a Linker, like your Washer  
needs a Dryer**

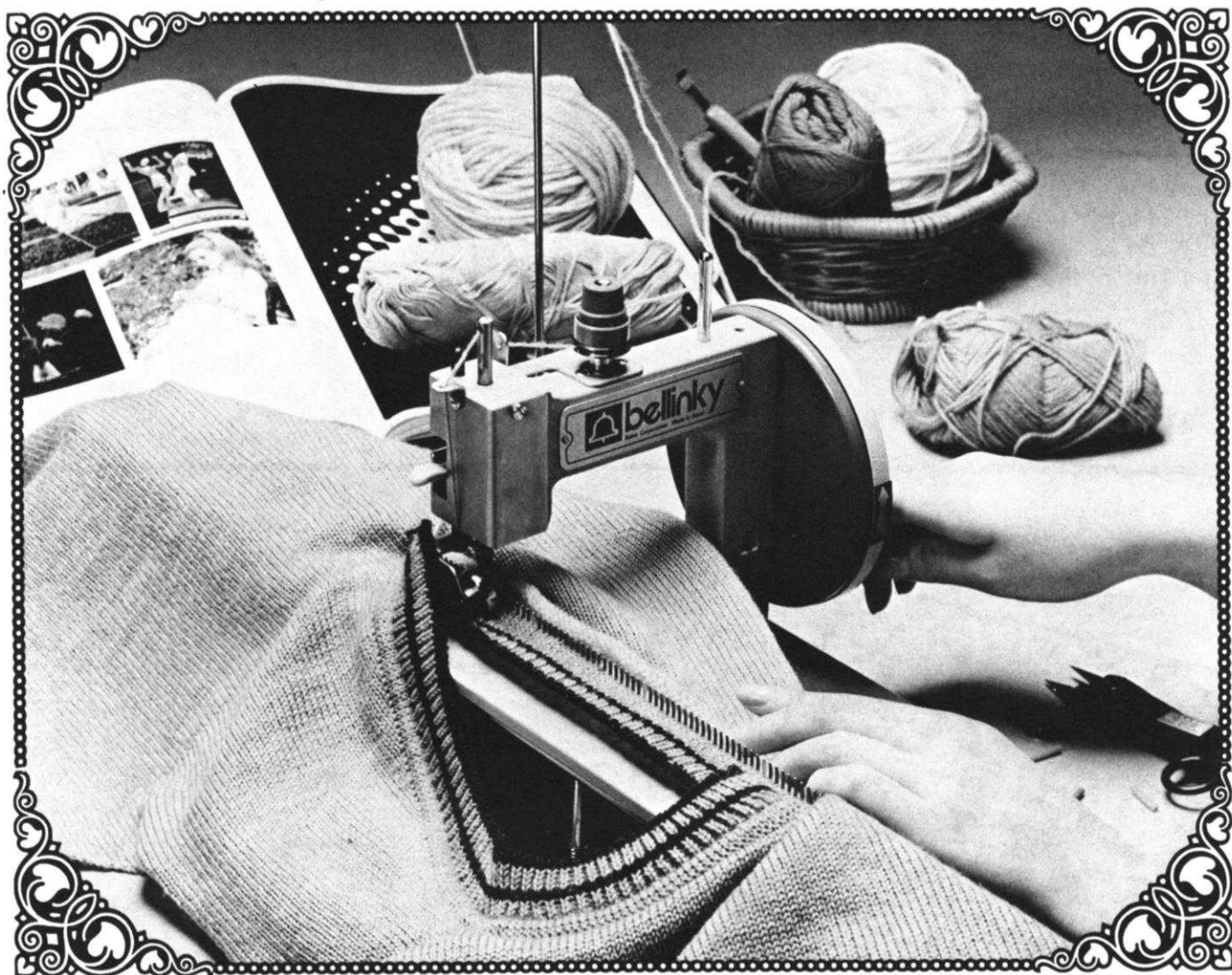

LINKING MACHINE  
**bellinky**

For fast easy and accurate assembly of all your knits you need BELLINKY. It seams, attaches sleeves and collars, pleats, shirrs and it lets you work lace, leather and other fabrics into your knitting.... BELLINKY is well engineered, lightweight, easy to carry, compact for storage.

Order direct from KNITKING  
1128 Crenshaw Blvd., Los Angeles, California 90019

# KNITKING has TWO NEW BABIES

BL3-407...

A heavy duty three thread cut and sew BABY LOCK that adjusts from 2.5 to 5mm width. (Rides over multiple layers of fabric (even denims) as easily as it will take the finer voiles. Color coded threading and tension adjustment.

PRICE: \$499.00

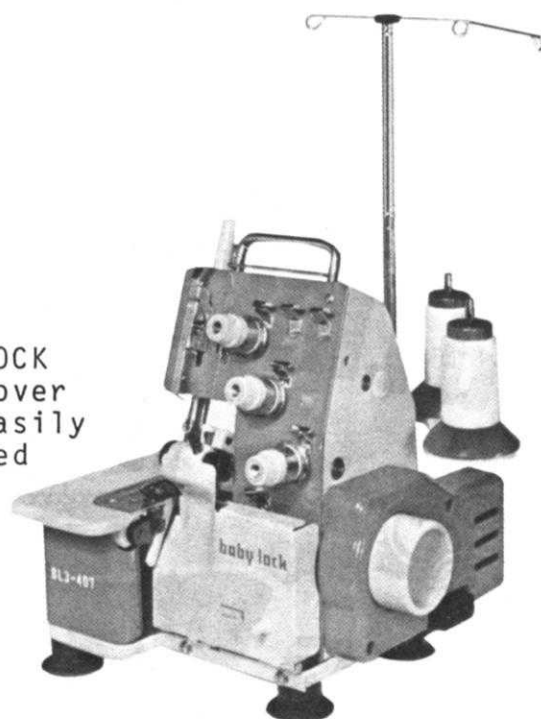

EF-405M...

The three thread cut and sew BABY LOCK especially for all fine fabrics... Perfect for lingerie with its 1.5mm setting...

Easy to adjust up to 3.5mm width for all fabrics.. Beautifully finishes the edges of sheers and even makes a perfect lettuce edging.

PRICE: \$479.00

ASK KNITKING FOR SPECIAL SUBSCRIBER PRICES...

## READY NOW ...

KNITKING MAGAZINE BOUND VOLUME NO. 14...

HARD BOARD COVER...

APPROXIMATELY 180 PATTERNS...

WITH COMPLETE INSTRUCTIONS...

PRICE...\$15.95

SHIPPING COSTS... 1.50



ORDER DIRECT FROM KNITKING - 1128 Crenshaw Blvd.  
Los Angeles, Calif. 90019

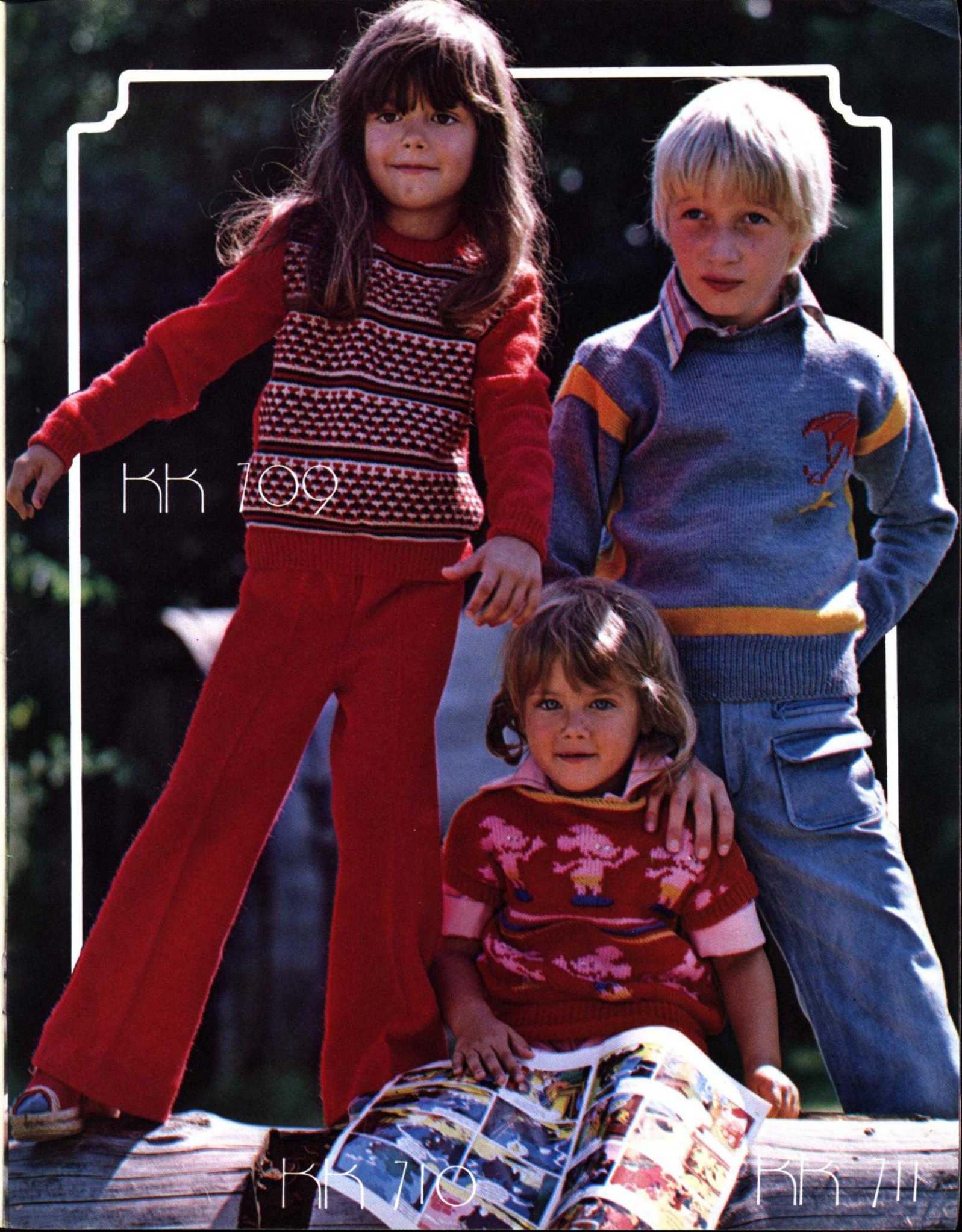

KK 709

KK 710

KK 711



KK 713



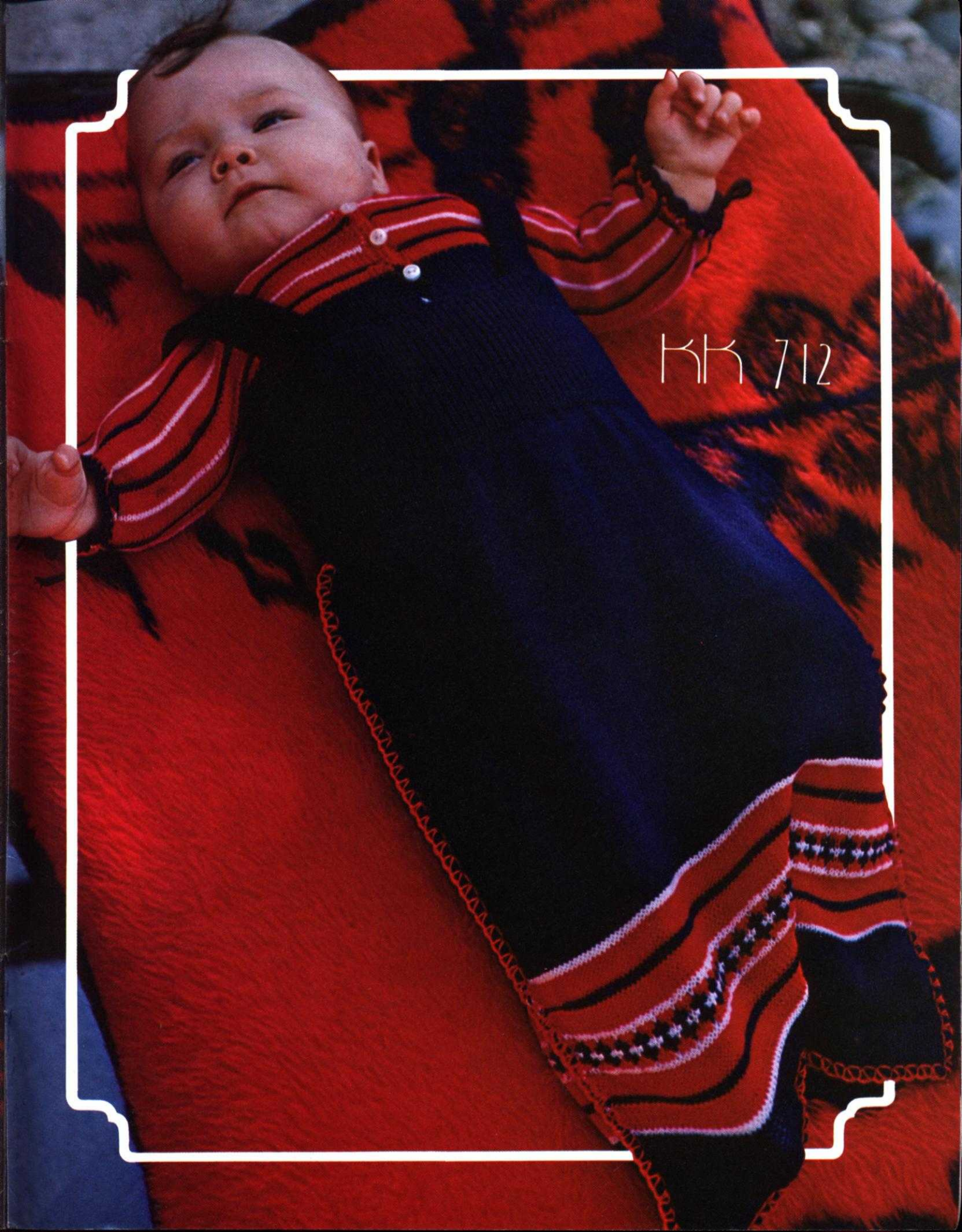

KK 712

HK 706



hp 699

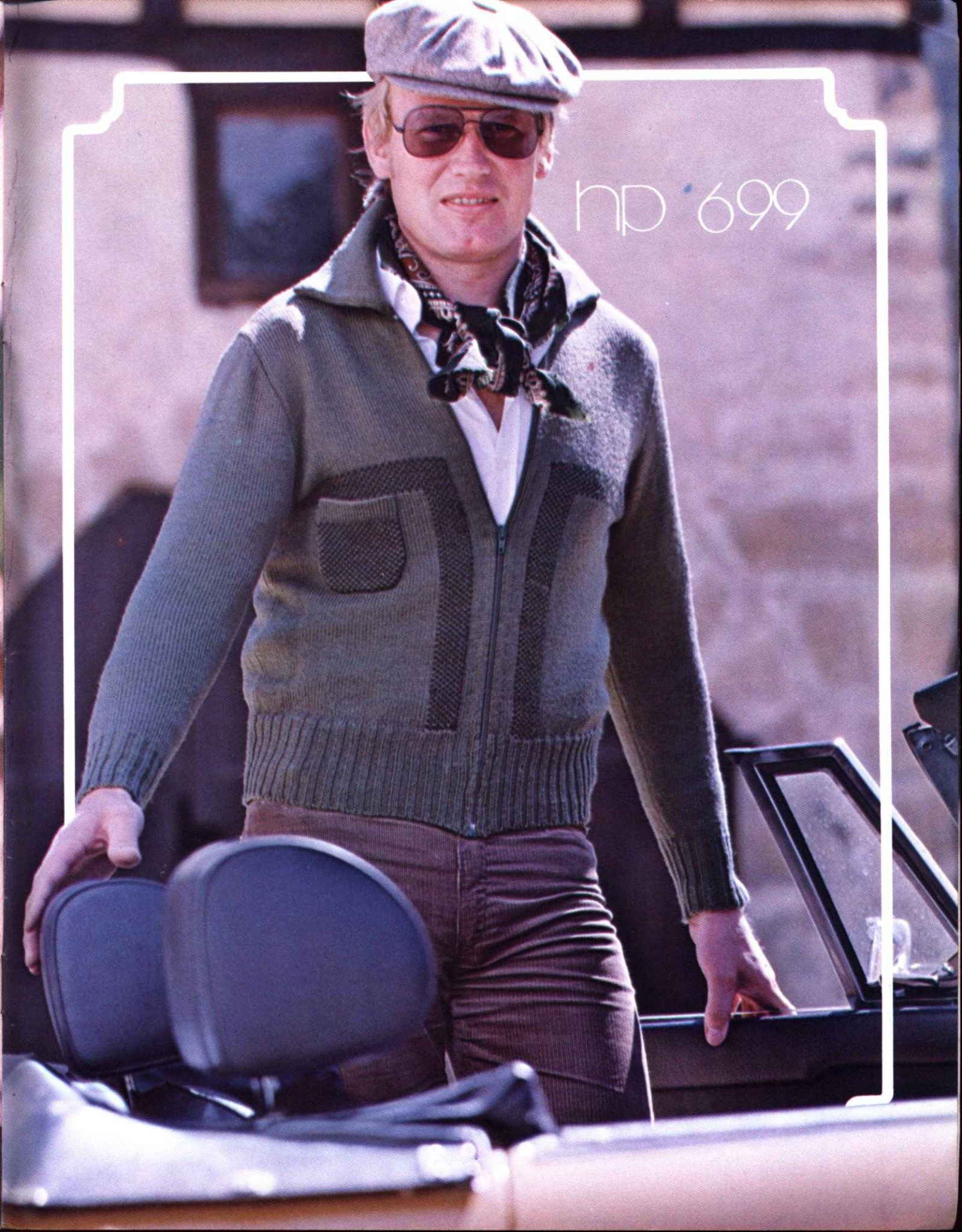

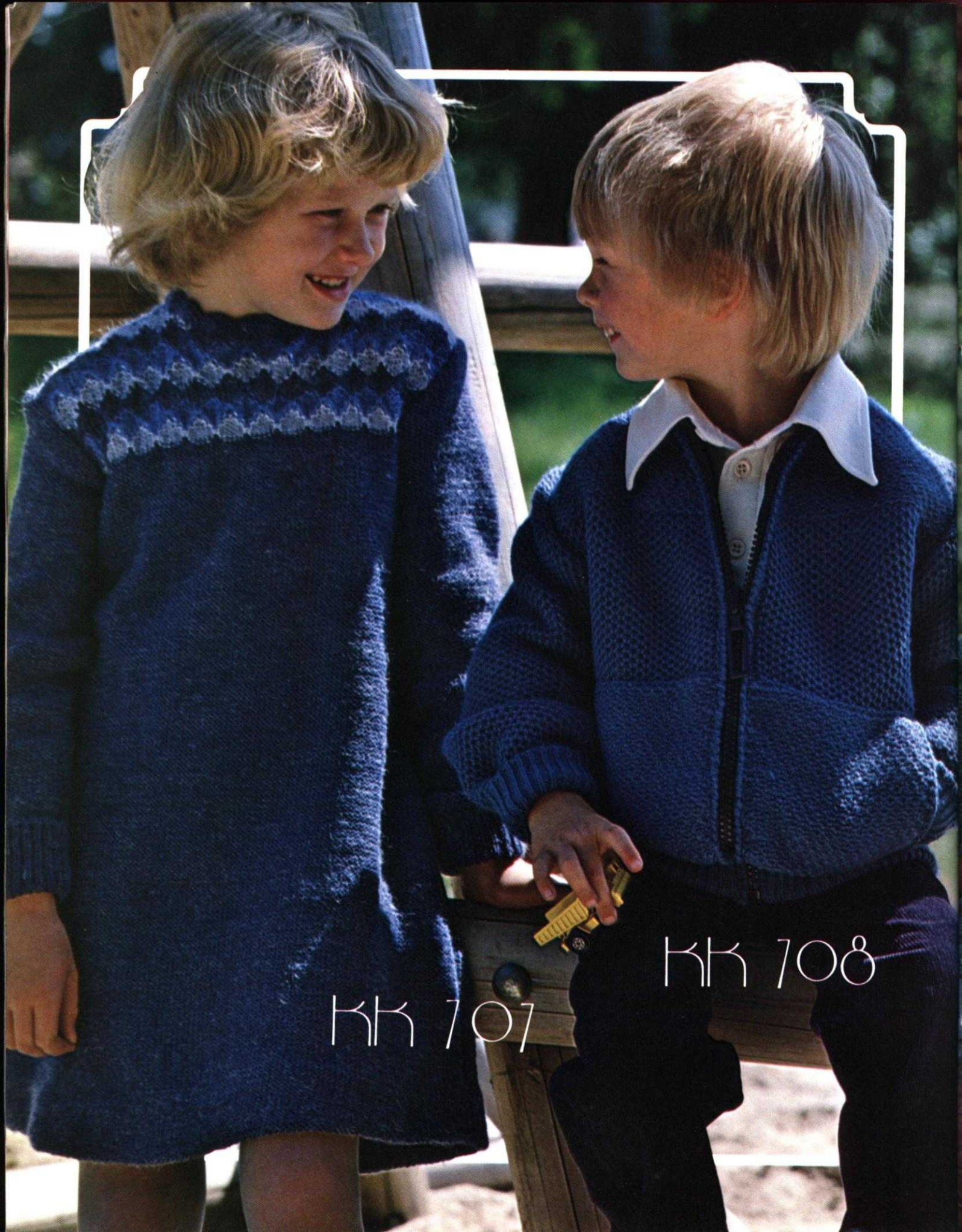

KK 707

KK 708

A photograph of three children in a forest setting. A young girl with brown hair is on the left, wearing a grey knit jacket. A boy with blonde hair is in the center, wearing a brown and tan striped cardigan. A boy with blonde hair is on the right, wearing a grey knit sweater and a checkered scarf. They are standing on a wooden log. The image is framed by a white decorative border.

KK 716

KK 715

KK 717

KK 714

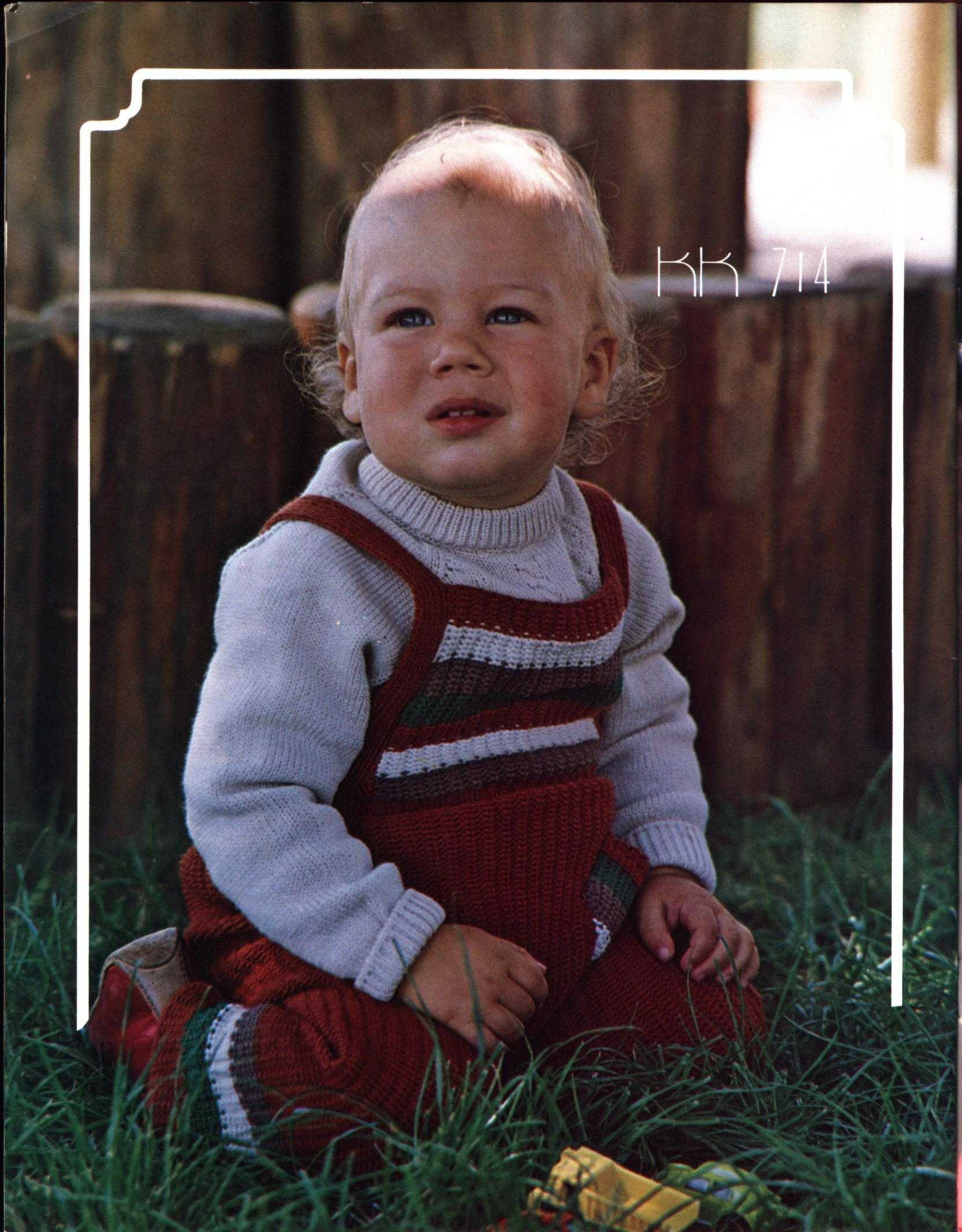

dk 703



mp 705

