

knitking

magazine





dk 564

X111277



dk 572

hp 566



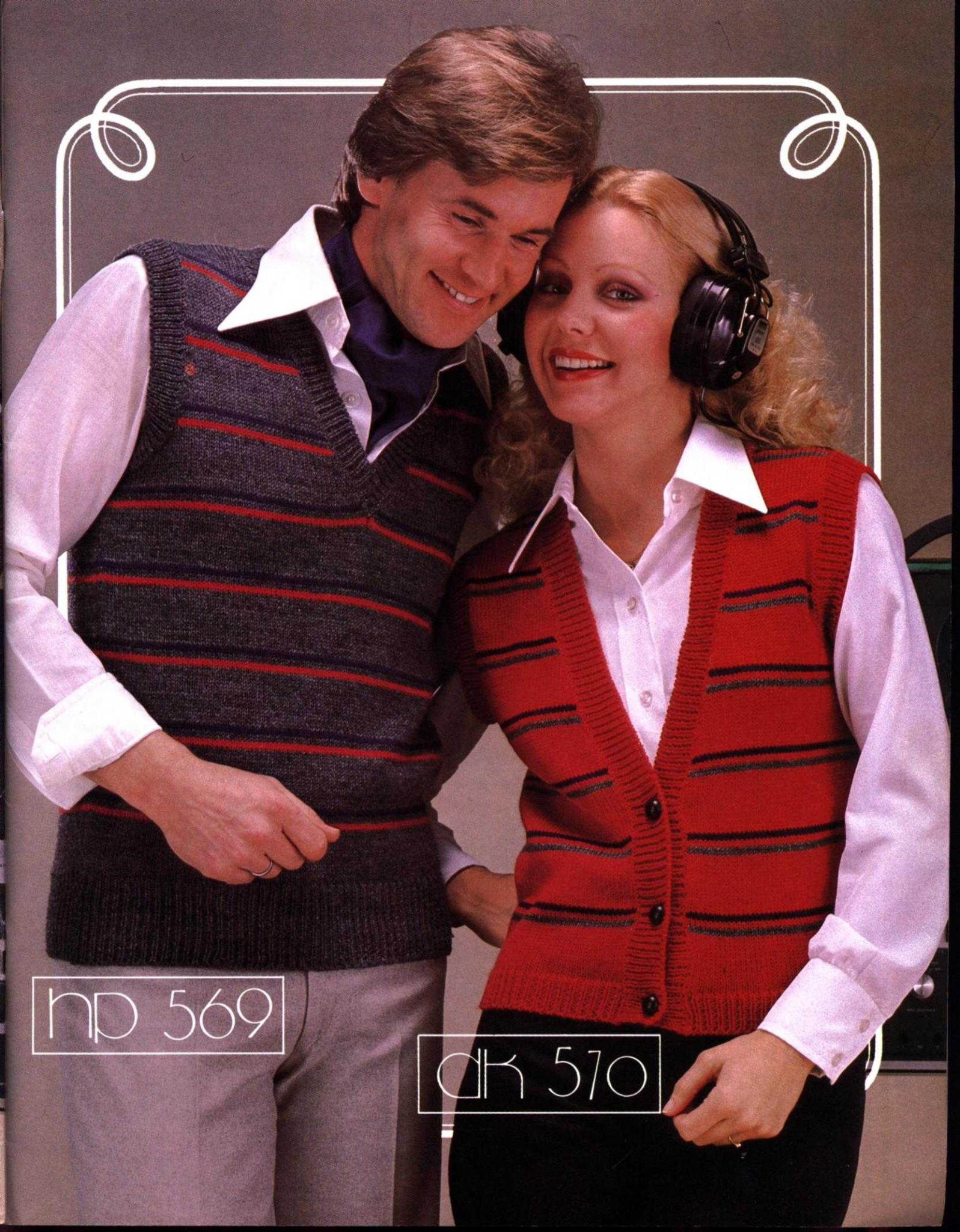

hp 569

dk 570



OK 571



dk 582

OK 574



DK 562

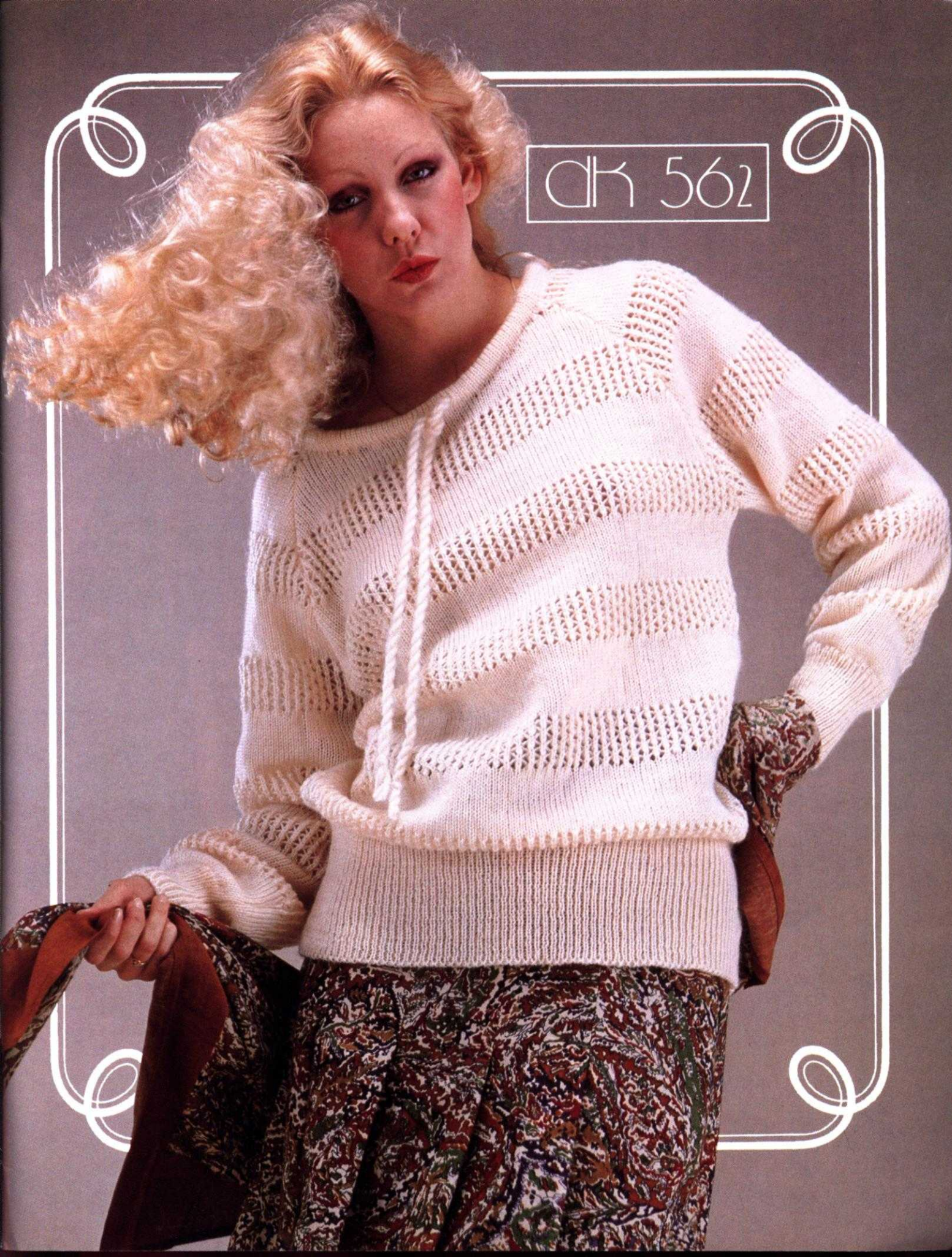



dk 573

knitking

magazine

VOLUME 14 No. 1

TABLE OF CONTENTS PAGE NO.

DK 560	Woman's Pullover & Legwarmers	14
DK 561	Woman's Jacket & Skirt	14
DK 562	Woman's Pullover	16
HP 563	Man's Pullover & Socks	17
DK 564	Woman's Two Piece Dress & Bag	18
DK 565	Woman's Eyelet Pullover	19
HP 566	Man's Jacket	20
KK 567	Boy's Pullover	21
DK 568	Woman's Long Pullover, Legwarmers Cap & Mittens	21
HP 569	Man's Sleeveless Pullover	22
DK 570	Woman's Vest	23
DK 571	Woman's Jacket	24
DK 572	Woman's Jacket & Skirt	24
DK 573	Woman's Pullover & Necklace Bag	26
DK 574	Woman's Bolero Jacket	26
DK 575	Woman's Jacket	27
HP 576	Man's Pullover	28
DK 577	Woman's Pullover	29
DK 578	Woman's Tennis Ensemble	30
KK 579	Child's Hooded Robe	33
DK 580	Woman's Blouse & Skirt	31
DK 581	Woman's Jacket	32
DK 582	Woman's Pullover & Scarf	35

editorial

We are carrying a full page advertisement in this issue for a new LINKING MACHINE... Its introduction will undoubtedly cause a sigh of relief among the thousands of machine knitters whose biggest and most tedious problem is the assembling of garments... Time and time again we are told by customers 'I love knitting on my machine but I hate putting the pieces together'... Take heart friends, relief is on the way. Get yourself one of our new Linkers and as soon as you do, your assembly problems will be over.

YOUR KNITTER NEEDS A LINKER LIKE YOUR WASHER NEEDS A DRYER....

All types of assembling can be done with the BELLINKY LINKER... You can join your side seams accurately and speedily and with the same yarn used in your knitting... You can turn an invisible hem... You can fit a neckline... sleeves... join squares or odd shapes together... insert horizontal or vertical panels... join suede, fur and other materials to your knitwear... neatly and accurately.

















Every BELLINKY LINKER is precision made with a die cast aluminum body plus stainless steel, copper and heavy duty working parts... KNITTING worked with BELLINKY for almost a year in preparing English Instructions and in the testing of their excellent product in order to insure satisfaction among our customers... When KNITTING guarantees a product, you can depend on it 100%. Everybody at KNITTING is excited about the new BELLINKY LINKER - we just know that you will be too...









As this Editorial is being written, I have the layout of the next edition on my desk and it promises to be truly outstanding with emphasis on style and femininity... The photography is fantastic, the garments gorgeous and the instructions easy to follow. Watch out for it...

Publisher: KNITTING CORPORATION, 1128 Crenshaw Blvd., Los Angeles, Calif. 90019. Telephone: (213) 938-2079. Published bi-monthly. Subscriptions: USA — \$12.00 annually, single copies \$3.00; Canada — \$14.00; other parts of the world — \$18.00. The entire contents of KNITTING MAGAZINE are copyright and must not be reproduced in any shape or form without the express permission, in writing of the publisher. © COPYRIGHT 1978 by KNITTING CORPORATION.













Pattern Symbols

Knitting – Chart Symbols

- () Size Symbols (2nd Size)
- < > 3rd Size
- ① Color Number
-  Cast on
-  Stitch
-  Row
-  Hem
-  Bind off
-  Stockinette stitch – worn on the Knit side.
-  Stockinette stitch – worn on the Purl side.
-  Knit 1, Purl 1 Ribbing
-  Ribbing Pattern – worn on the Knit side.
-  Ribbing Pattern – worn on the Purl side.
-  Closed Dart
-  Open Dart
-  Put on a stitch holder
-  Reverse 1 section
-  On every other needle
-  Number of Rows between Shapings. Make increase (or decrease) FIRST, then knit 4 rows. For example: 3 x 1  means decrease (or increase) 1 st., knit 4 rows; decrease 1 st., knit 4 rows; decrease 1 st., knit 4 rows; decrease 1 st., knit 4 rows. All decreasing (or increasing) without row numbers as shown must be shaped on every 2nd row.

-  Increase
-  Increase 2 sts. With a transfer tool, move the sts. over the left (or right) leaving 2 empty needles at the point of increase. At the increase point, move 1 st. to the left, (or right) so that there is an empty needles on each side of a stitch. On each side of the center stitch, pick up a stitch from the row below and hang it onto the empty needle.
-  3 stitches on 1 needle. The 1st and 3rd stitch in a group of 3 has been hung on the 2nd or center needle.
-  Short Row increase or decrease; for instance on a flared skirt knitted sideways.
-  Pattern Stitch
-  Pattern Stitch – worn on the Knit side.
-  Pattern Stitch – worn on the Purl side.
-  Repeat
 - I = Front
 - II = Back
 - III = Sleeve
 - IV = Skirt Front
 - V = Skirt Back
 - VI = Collar
 - VII = Pocket
 - VIII = Band
 - IX = Belt
 - X = Cuff
 - XI = Pants Front
 - XII = Pants Back

Finishing – Chart Symbols

-  Match numbers on section for assembling.
-  Ease
-  Fold Line
-  Turn to the wrong side and hem.
- Stitch Symbols**
 -  Needles in holding position
 -  Needles back into working position.
 -  Empty needle (leave in working position)
 -  Needle not used (in the out of work position).
 -  Two stitches on 1 needle, either transferred from the right side or the left side, then put into holding position.
 -  Needle holding 2 stitches. Stitch has been transferred from the RIGHT.
 -  Needle holding 2 stitches. Stitch has been transferred from the LEFT.
 -  Center of garment section



General Instructions

HOW TO READ THE CHARTS AND INSTRUCTIONS

There are 3 sizes given for each Pattern in KNITTING MAGAZINE. Above each Chart for the different sizes, you will see that the first and smaller sizes might be shown as 8/10, the second size as (12/14) and the third as [16/18]. Check the measurements at the bustline and hips on the Charts to be certain that you will knit the correct size, remembering these are ACTUAL measurements of the completed section and that there must be a bigger allowance at the bustline and hipline for a Jacket or a Coat than there would be for a fitted dress or a fitted blouse or pullover. The question in your mind should be "How do I want this garment to fit...?"

When you have chosen the size you need, you can follow the Charts as shown. You will notice that where the shapings are the same FOR ALL SIZES, only 1 set of shapings will be shown on the first Chart and if you are knitting the 2nd or 3rd size, you simply follow the shapings as given for the first size. If the shapings are different, this will be shown on the Charts and you should follow them as given.

On the Charts, increases and decreases will be shown as follows

5x1

6 The number in the box means number of ROWS between the shapings, while the 5x1 above the box means - 1 st. 5x... so you will increase or decrease 1 st. every 6th row 5x.

ARMHOLE SHAPINGS - NECK SHAPINGS - SHOULDER SHAPINGS - are made on every 2nd row UNLESS there is a number in a box along side or below the shapings. The rule is... where there is no box with a number, the shaping is made on every 2nd row.

THE PRINTED INSTRUCTIONS

You can follow the printed instructions or use them in combination with the Charts. Where there is any question in the printed instructions, you have the Charts to show you how the section will look.

The 3 sizes, with the different amounts of cast on stitches and the different shapings will look like this...

Cast on 124 (136) [148] sts. You will
Cast on 124 sts. for the first size.
Cast on 136 sts. for the 2nd size.
Cast on 148 sts. for the 3rd size.

The important thing to remember is that you MUST READ AHEAD so that you KNOW what to do for the size you are knitting. Sometimes where the number of stitches are the same but the number of times different, you will find shapings like this...
3 sts. 1x (2x) [3x], 2 sts. 1x (2x) [3x], 1 st. 3x (4x) [5x].
As you see, you MUST read ahead in order to follow the instructions as given for YOUR SIZE. The rows will be different for the different sizes in some cases... Shoulder and Neck shapings usually are worked at the SAME TIME for the back section - so watch for the words AT THE SAME TIME.

HOLDING STITCHES ON THE LEFT SIDE WHILE SHAPING THE RIGHT SIDE

When knitting a section of garment in stockinette stitch, it is easy to hold the stitches on the left side while knitting the right half, but when knitting a Pattern Stitch such as a Norwegian Design, a Holding Position Design, Weaving, etc., you should use the following method. For the NECK SHAPING, we tell you to bind off the center sts., put the needles on the left into holding position and complete the right half first... so with a strand of contrast yarn, knit ALL of the left side stitches manually by hand, pulling each stitch back against the needle bed to the OUT OF WORK position. When the right side is completed, carefully pull the stitches held on contrast, forward into working position and as you do so, undo the contrast yarn, line up the needles (KNITTING AM 3 machine owners, put the stitches under the sinkers) and complete the left half.

If you own a Japanese machine, you may find that when knitting the right half with the left side held in this way, the sinker plate will mark the left side while you are knitting the right half. To prevent this marking, you can tape a piece of paper over the knitting, underneath the sinkers, or if you own a Reversing Bar, you can hang this onto the Sinkers while you are knitting the right half. When hanging the Reversing Bar, be sure the eyes of the bar go BETWEEN the Sinker Posts on the upper part of the bar so that the tips of the bar only - show above the needle bed.

FULL FASHION DECREASING OR INCREASING

For Stockinette stitch, always use the Full Fashion method for increasing or decreasing.

TO DECREASE: Hang the 3rd stitch onto the 2nd stitch then move the stitches in to fill the empty needle.

TO INCREASE: Move the 2 end stitches 1 needle outward, then pick up the 3rd stitch from the row below and hang it onto the empty needle.

FINISHING: Block all sections. For PULLOVERS, JACKETS, and DRESSES: Join front to back at sides and shoulders. Sew sleeves together and set in. Hem lower edge and sleeve edges if needed. For a double neckband or armhole band, sew 1 edge to the inside and 1 to the outside of neck or armhole. For a single ribbed band, sew 1 edge to the outside of neck or armhole edge. For a cardigan or jacket with buttonholes, finish buttonholes and sew on buttons.

PANTS: Join front to back at sides. Sew inside leg seams, then join center front and back. Make hem at waistline and insert elastic. Hem lower edge of pants legs.

THE SAMPLE SWATCH

Before you begin to knit any garment, you will need to knit a sample piece using the yarn you have chosen for your garment, so that you can check the stitch and row gauge which must measure the correct number of stitches and rows in 5 cm (2 inches).

For each Pattern in KNITTING MAGAZINE, we give you 3 tension numbers to work from and if you use the specified yarn for the garment, you should be able to get the correct stitch and row gauge using one of these numbers. Here is a very easy way to make your sample swatch and count the stitches and rows without actually counting, by using our KNITTING Converta Tape.

Supposing the Tension Numbers for the Stitch and Row Gauge are given as 5 to 7. Set the Tension Dial to the first number which is 5. With contrast waste yarn, and using the quick cast on method, cast on 60 stitches and knit 10 rows. Change to garment yarn and turn the Row Counter to 0. Knit 30 rows. Counting from each end, knit the 10th stitch on each side by hand with a small piece of contrast yarn. Leave the needles in working position and knit 30 rows (Row 60), then knit 4 rows with contrast waste yarn. Turn the Row Counter to 0 and the Tension Dial to 6 and with garment yarn, knit 30 rows. Mark the 10th stitch on each side as you did before, knit 30 rows, then 4 rows with contrast waste yarn. Turn the Row Counter to 0 and with Tension 7, repeat the above once more, ending with 10 rows of contrast waste yarn. Remove the work from the machine by passing the Slide across the needles without yarn (sometimes called 'dropping').

Pull and stretch the sample piece both lengthwise and diagonally from corner to corner, then lengthwise again. Do not count the stitches and rows immediately, but allow the sample to rest for several hours or even over night. This will allow the stitches and rows to return to their basic form.

When your sample has rested and you are ready to count the stitches and rows, the KNITTING CONVERTA TAPE will do the counting for you without any counting on your part. Use the Tape as follows:

Measure the stitches with the TAPE, BETWEEN the 40 stitches marked with contrast waste yarn. Push the SLIDE so that the LEFT EDGE lines up to this exact measurement. Now look down along side the SLIDE and find the number 40 on the TAPE. The number directly opposite on the SLIDE will be your Stitch Gauge to 5 cm (2"). To find the number of rows in 5 cm (2"), place the TAPE to measure over the 60 rows, push the SLIDE to this number with the left edge lined up, the look for the number 60 on the TAPE and directly opposite this will be the number of rows to 5 cm (2")

If you do not own a KNITTING CONVERTA TAPE, you must mark a 5 cm (2 inch) square in the center of the knitting, then count the number of stitches and rows within the square.

dk 560



WOMAN'S PULLOVER & LEGWARMERS

SIZE: 8/10
 YARN: Amore
 GRAMS: color 1 - 600
 color 2 - 200
 TENSION: 8 to 10
 GAUGE: 12 sts. 18 rows = 5 cm (2")

Pullover: Stockinette stitch with color stripes. Collar and lower band in 3 and 1 Ribbing. Cuffs: K1, P1 Ribbing. Legwarmers: 3 and 1 Rib with ankle and upper bands: K1, P1 Ribbing.

FINISHING: See General Instructions. Knit a cord over 2 needles then pull through eyelets of Pullover or you can make a twisted cord.

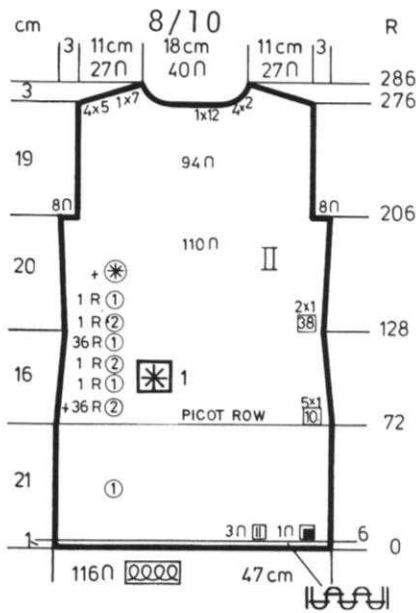

PULLOVER BACK: II

Cast on 116 sts. with color 1 and work K3, P1 Ribbing to Row 72. Transfer the Rib sts. to the main machine, placing it onto the nearest needle in working position. Knit 1 row, then bring the empty needles of main machine into working position and continue in Stockinette stitch with color 2 following the Chart for the change in color stripes. ON EACH SIDE decrease 1 st. every 10th row 5x. After Row 128, ON EACH SIDE, increase 1 st. every 38th row 2x. After Row 206, ON EACH SIDE, bind off 8 sts. for armhole. Knit to Row 276. SHAPE SHOULDER AND NECK AT THE SAME TIME. Put half the sts. on the left into holding position and complete the right side first. *FOR SHOULDER, bind off 5 sts. 4x, 7 sts. 1x. FOR NECK, bind off 12 sts. 1x, 2 sts. 4x. Bring the needles on the left into working position, knit 1 row to the left side, turn the Row Counter back to 276 and complete the left half. Follow the instructions from *.

dk 561

WOMAN'S JACKET & SKIRT

SIZES: 8/10 (12/14) [16]
 YARN: color 1 = Vienna
 color 2 and 3 = Amore
 GRAMS:
 color 1 700 750 800
 color 2 250 300 300
 color 3 250 300 300
 TENSION: 6 to 8
 GAUGE: 14 sts. 21 rows = 5 cm (2")



Purchased Braid to go around edges (see picture). 3 buttons. Zipper for skirt if needed.

A Weaving Pattern. Use Card No. 2D from 830 Pattern Cards or Punch your own Card. Colors 2 and 3 are used TOGETHER for the Weaving.

FINISHING: See General Instructions. Work 1 row single crochet around all edges then sew on Braid (see picture). Finish Buttonholes and sew on buttons. SKIRT: Sew in the darts.

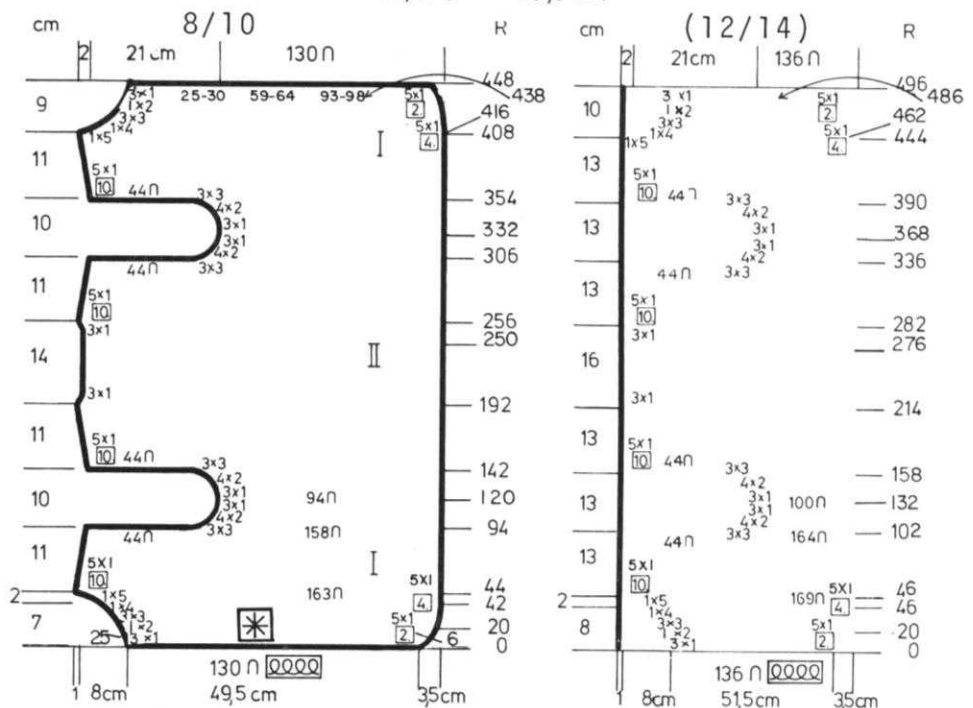
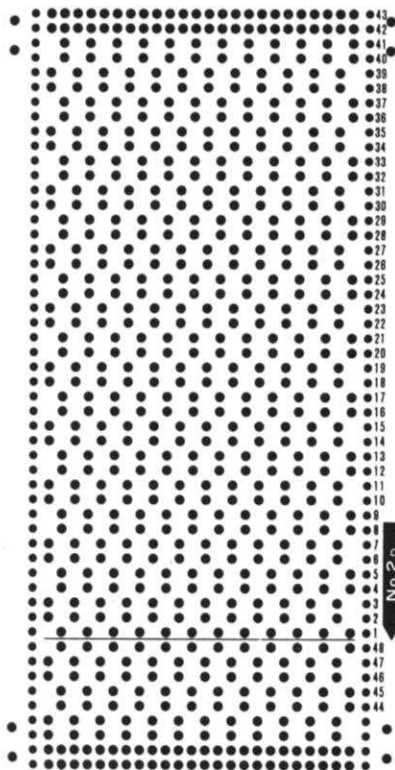
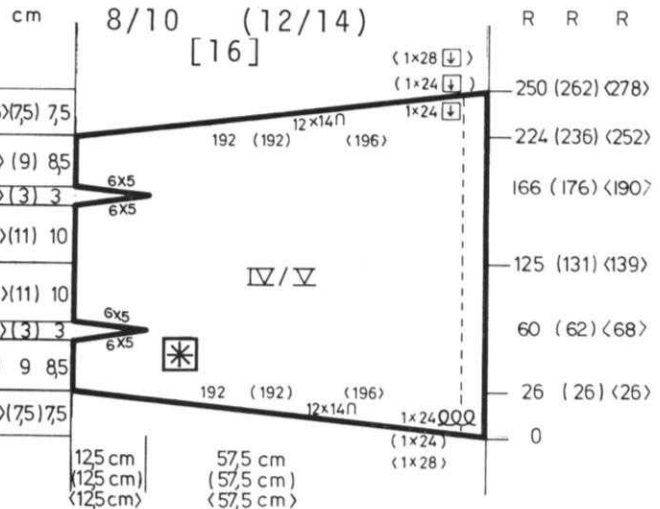

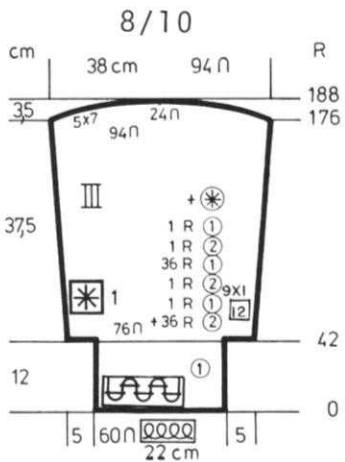

SLEEVES: III
 With contrast waste yarn, cast on 76 sts. and work Stockinette stitch. Knit 8 to 10 rows, change to color 2 and put Counter at 42. Continue with the color stripes as shown on the Chart. ON EACH SIDE, increase 1 st. every 12th row 9x.
 After Row 176, ON EACH SIDE, bind off 7 sts. 5x. After Row 188, bind off the remaining sts.

Hang the open sts. of the cast on back onto the machine decreasing to 60 sts. Transfer every other stitch to the Ribber and work 42 rows K1, P1 Ribbing with color 1. Bind off the crochet method for Ribbing.

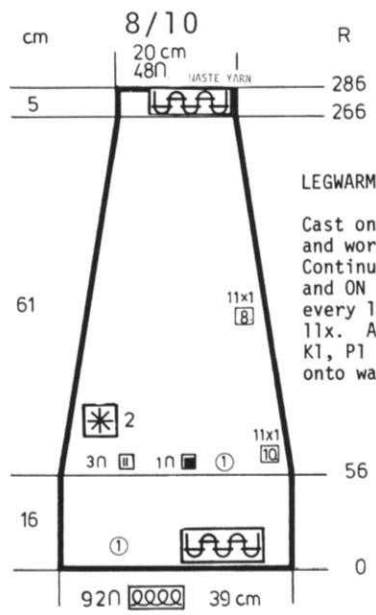

LEGGWARMERS: Make 2.
 Cast on 92 sts. with color 1 and work K1, P1 Ribbing to Row 56. Continue with K3, P1 Ribbing and ON EACH SIDE, decrease 1 st. every 10th row 11x, every 8th row 11x. After Row 266, continue with K1, P1 Ribbing to Row 286. Remove onto waste yarn.

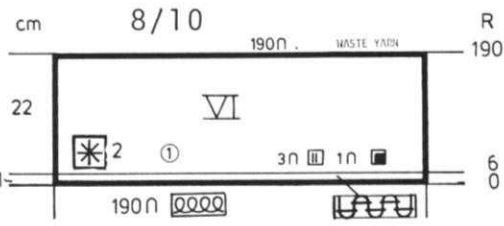

COLLAR: VI
 With color 1 cast on 190 sts. and work K3, P1 Ribbing to row 190 then bind off the crochet method for Ribbing.

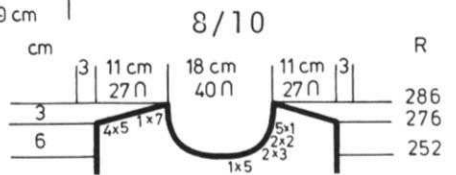

FRONT: I
 Work the Front the same as the Back to Row 252. Put half the sts. on the left into holding position and complete the right side first.
 *ON NECK SIDE, bind off 5 sts. 1x, 3 sts. 2x, 2 sts. 2x, 1 st. 5x and SHAPE SHOULDER same as the back after Row 276. Bring the needles on the left into working position, knit 1 row to the left side, turn the Row Counter back to 252 and complete the left half. Follow the instructions from *.

SKIRT: Make 2 sections the same.

To the extreme right side of machine cast on and work in Pattern 24 sts. 1x (24 sts. 1x) [28 sts. 1x] then cast on 14 sts. 12x for all sizes. After Row 59 (61) [67], bind off 5 sts. 6x then immediately cast on 5 sts. 6x (dart). Knit to Row 165 (175) [189]. Bind off 5 sts. 6x then immediately cast on 5 sts. 6x (dart). After Row 223 (235) [251], bind off 14 sts. 12x for all sizes then bind off 24 sts. 1x (24 sts. 1x) [28 sts. 1x].

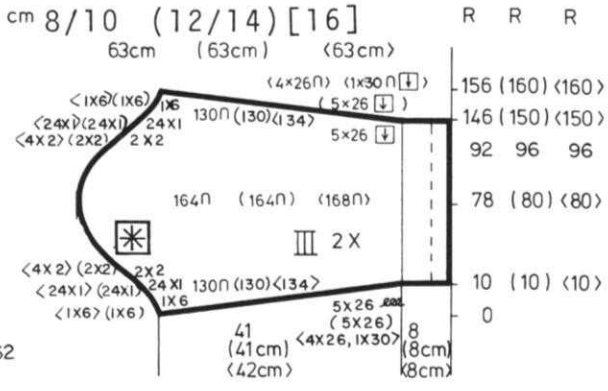

FRONT & BACK JACKET: Knitted sideways on the machine. I & II
 Cast on 130 (136) [136] sts. and work in Pattern. After Row 6, increase 1 st. every 2nd row 5x, every 4th row 5x and after Row 25 (neck side) cast on 1 st. 3x, 2 sts. 1x, 3 sts. 3x, 4 sts. 1x, 5 sts. 1x.
 After Row 43 (43) [45] SHAPE SHOULDER: Decrease 1 st. every 10th row 5x.
 After Row 93 (97) [101] SHAPE ARMHOLE: Bind off 44 sts. then bind off 3 sts. 3x, 2 sts. 4x, 1 st. 3x, After Row 119 (125) [131] cast on 1 st. 3x, 2 sts. 4x, 3 sts. 3x, then cast on 44 sts.
 After Row 141 (149) [157], increase 1 st. every 10th row 5x.
 After Row 191 (203) [213], SHAPE NECK: Bind off 1 st. 3x.
 After Row 249 (261) [275], cast on 1 st. 3x.
 After Row 255 (267) [281], SHAPE SHOULDER: Bind off 1 st. every 10th

SLEEVES: III
 Cast on 26 sts. 5x (26 sts. 5x) [26 sts. 4x, 30 sts. 1x] and work in Pattern.
 After Row 9, SHAPE CAP: Cast on 6 sts. 1x, 1 st. 24x, 2 sts. 2x (2x) [4x].
 Mark Row 78 (80) [80] on each side for center of sleeve.
 After Row 91 (95) [95], bind off 2 sts. 2x (2x) [4x], 1 st. 24x, 6 sts. 1x.
 After Row 146 (150) [150], bind off 26 sts. 5x (26 sts. 5x) [30 sts. 1x, 26 sts. 4x].
 After Row 305 (321) [335], SHAPE ARMHOLE: Bind off 44 sts., then bind off 3 sts. 3x, 2 sts. 4x, 1 st. 3x.
 After Row 331 (351) [367], cast on 1 st. 3x, 2 sts. 4x, 3 sts. 3x. then cast on 44 sts.
 After Row 353 (373) [389], SHAPE SHOULDER: Decrease 1 st. every 10th row 5x.
 After Row 407 (427) [443], SHAPE NECK: Bind off 5 sts. 1x, 4 sts. 1x, 3 sts. 3x, 2 sts. 1x, 1 st. 3x and after Row 416 (440) [462], decrease 1 st. every 4th row 5x, every 2nd row 5x and WATCH FOR BUTTONHOLES. Make BUTTONHOLES after Row 438 (462) [486] over needles 25 to 30, 59 to 64, 93 to 98 counting from the LEFT edge.
 After Row 448 (472) [496], bind off the remaining sts.

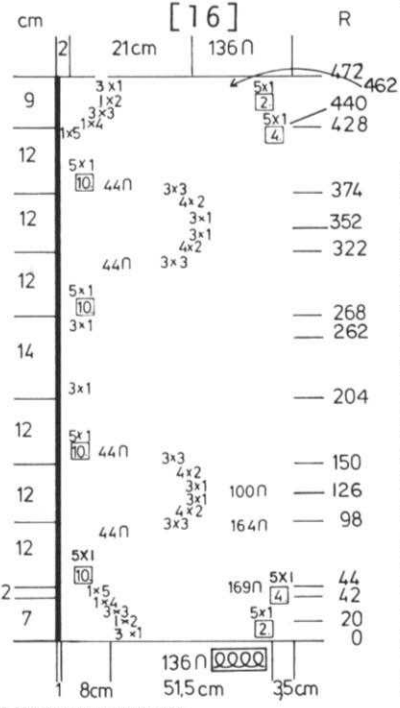

dk 562



WOMAN'S PULLOVER

SIZES: Fits sizes 12 to 16
YARN: Allegro
GRAMS: 400
TENSION: 7 to 9
GAUGE: 11 sts. 17 rows = 5 cm (2")

Stockinette stitch with an Eyelet Design. Punch your own Card or follow the Line Drawing and work 16 rows Eyelet Design, 20 rows Stockinette stitch. Lower band and sleeve bands are K1, P1 Ribbing.

FINISHING: See General Instructions. Turn under half the neckband sts. and sew in place. Make a Cord over 4 needles for as long as you need then pull through casing at neck.

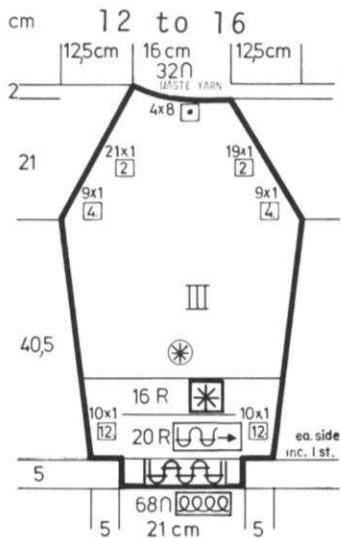

SLEEVES: III

Cast on 68 sts. and work 20 rows K1, P1 Ribbing. Continue in Pattern beginning with 20 rows Stockinette stitch, and increase 1 st. ON EACH SIDE. Increase 1 st. ON EACH SIDE every 12th row 10x.
 After Row 150 SHAPE RAGLAN: ON EACH SIDE, decrease 1 st. every 4th row 9x, then every 2nd row ON CAM BOX SIDE, decrease 1 st. 19x and on OPPOSITE SIDE OF CAM BOX, decrease 1 st. 21x.
 After Row 227, WORK SHORT ROWS: ON OPPOSITE SIDE OF CAM BOX, put into holding position, 8 sts. 4x.
 After Row 232, bring all the needles into working position and remove onto contrast waste yarn as you did before.
 Work the 2nd sleeve with REVERSE SHAPINGS.

FRONT: I

Work the front the same as the back to Row 158.
 SHAPE RAGLAN: ON EACH SIDE, decrease 1 st. every 4th row 6x, every 2nd row 25x, BUT AT THE SAME TIME, after Row 210, SHAPE NECK: Put half the sts. on the left into holding position and complete the right side first.
 *WORK SHORT ROWS: ON NECK SIDE, put into holding position, 8 sts. 1x, 4 sts. 2x, 2 sts. 4x, 1 st. 5x. Put these sts. into holding position, move the Cam Box to the left side, turn the Row Counter back to 210 and complete the left half. Follow the instructions from * and don't forget to complete the raglan shaping.
 After Row 232, bring all the needles into working position and remove them onto Contrast waste yarn as you did for the back.

FRONT: I

Work the front the same as the back to Row 214 (218) [218]. Put half the sts. on the left into holding position and complete the right side first.
 *ON NECK SIDE, bind off 5 (5) [6] sts. 1x, then for all sizes bind off 4 sts. 1x, 3 sts. 2x, 2 sts. 3x, 1 st. 5x. and SHAPE SHOULDER same as the back after Row 240 (244) [246]. Bring the needles on the left into working position, knit 1 row in Pattern to the left side, turn the Row Counter back to 214 (218) [218] and complete the left half. Follow the instructions from *.

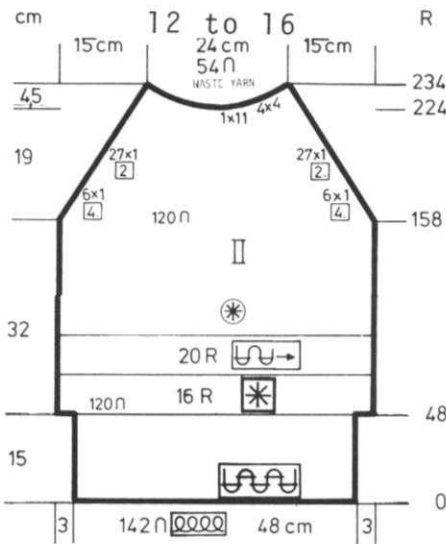

BACK: II

Cast on 142 sts. and work 47 rows K1, P1 Ribbing. Remove the sts. onto contrast waste yarn. Hang the sts. back onto the MAIN machine, decreasing 22 sts. evenly across (120 sts.). Knit 1 row Stockinette stitch to the right side. Row Counter at 48.
 Work in Pattern of 16 rows Eyelet Design, 20 rows Stockinette stitch. After Row 158 SHAPE RAGLAN: ON EACH SIDE, decrease 1 st. every 4th row 6x, every 2nd row 27x, BUT AT THE SAME TIME, after Row 224, SHAPE NECK: Put half the sts. on the left into holding position and complete the right side first.
 *Work SHORT ROWS. ON NECK SIDE, put into holding position 11 sts. 1x, 4 sts. 4x. Put these sts. into holding position, move the Cam Box to the left side, turn the Row Counter back to 224 and complete the left half. Follow the instructions from * and don't forget to complete the raglan shaping.
 After Row 234, remove ALL the sts. onto contrast waste yarn. (You can knit 1 row stockinette stitch over the all the neck sts. first).

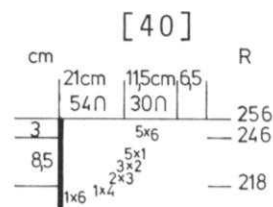
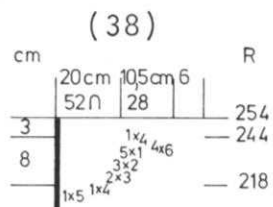
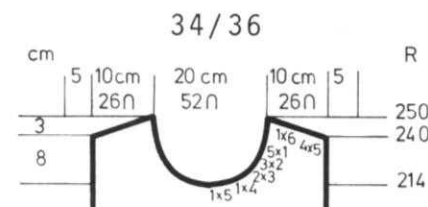
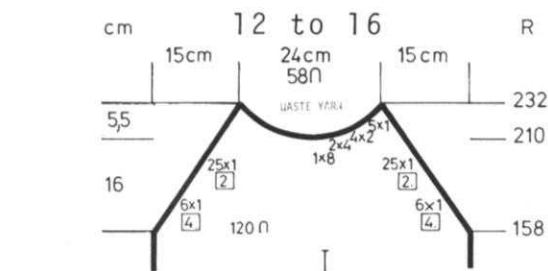
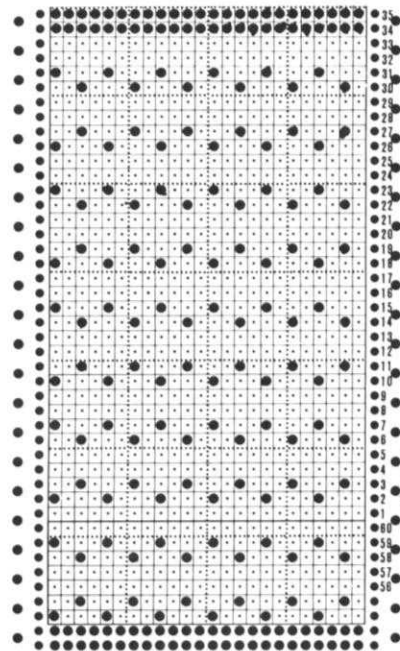
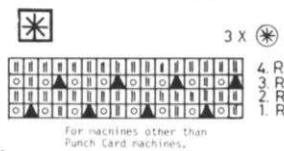

hp 563

MAN'S PULLOVER & SOCKS

SIZES: 34/36 (38) [40]
 YARN: Fortissima
 GRAMS: Pullover 600 650 700
 Socks 100 100 100
 TENSION: 7 to 9
 GAUGE: 13 sts. 18 rows = 5 cm (2")

A Ribbing Pattern forming a basket weave - 8 sts. on the main machine and 8 sts. on the Ribber. Every 10 rows, the stitches are reversed.

FINISHING: See General Instructions.
 SOCKS: Weave the open sts. of the heel sections together then remove waste yarn. Sew up back seam.



Begin and end with 6 pur1 sts. (Main machine).
 After every 10 rows, transfer the Ribber sts. to main machine and the main machine sts. to the Ribber.

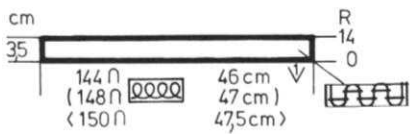
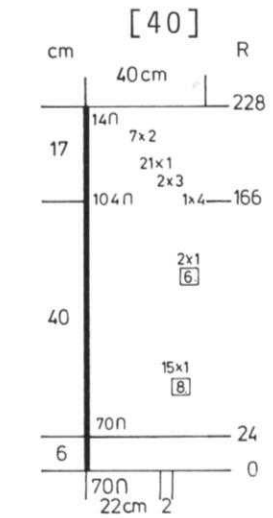
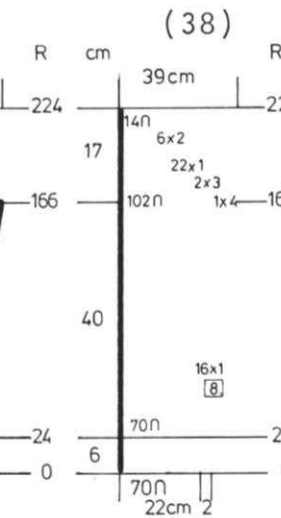
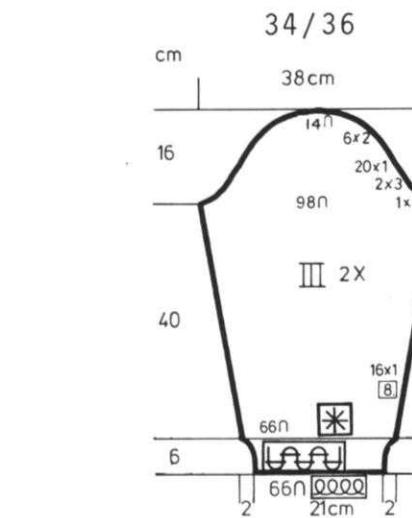
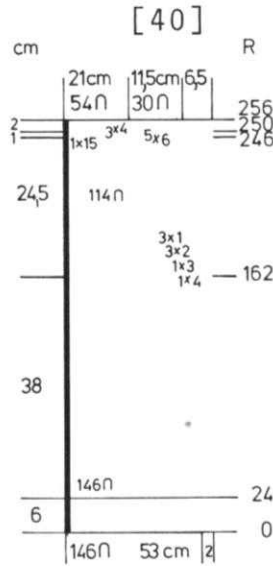
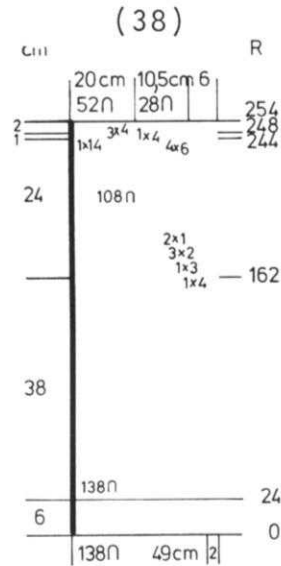
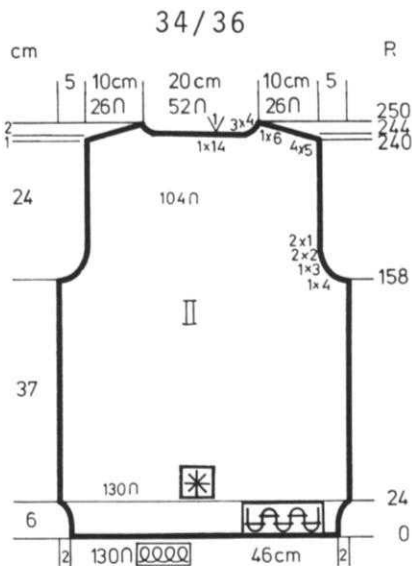

NECKBAND:
 Cast on 144 (148) [150] sts. and work 14 rows K1, P1 Ribbing. Bind off the crochet method for Ribbing.

SOCKS Make 2.

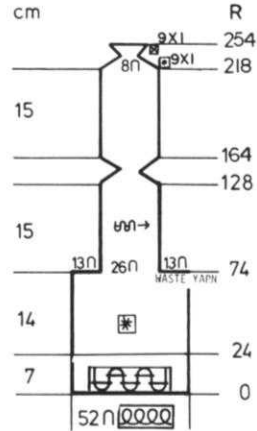

Cast on 52 sts. and work 24 rows K1, P1 Ribbing.
 Continue in Pattern to Row 74 then continue in Stockinette stitch.
 ON EACH SIDE, remove 13 sts. onto contrast waste yarn.
 Knit to Row 128 then work SHORT ROWS: *ON OPPOSITE SIDE OF CAM BOX, put into holding position, 1 st. 9x on each side. ON OPPOSITE SIDE OF CAM BOX, bring back into working position 1 st. on each side till all are in work.**
 Knit to Row 218. REPEAT the SHORT ROWS from * to ** then remove the sts. onto contrast waste yarn.

BACK: II

Cast on 130 (138) [146] sts. and work 24 rows K1, P1 Ribbing.
 Continue in Pattern.
 Knit to Row 158 (162) [162].
 SHAPE ARMHOLE: ON EACH SIDE, bind off 4 sts. 1x, 3 sts. 1x, 2 sts. 2x, 1 st. 2x.
 (4 sts. 1x, 3 sts. 1x, 2 sts. 3x, 1 st. 2x).
 [4 sts. 1x, 3 sts. 1x, 2 sts. 3x, 1 st. 3x].
 Knit to Row 240 (244) [246].
 SHAPE SHOULDER and watch for NECK SHAPING:
 FOR SHOULDER, ON EACH SIDE bind off 5 sts. 4x, 6 sts. 1x.
 (6 sts. 4x, 4 sts. 1x).
 [6 sts. 5x, 4 sts. 3x].
 FOR NECK: After Row 244 (248) [250] put half the sts. on the left into holding position and complete the right side first.
 *ON NECK SIDE, bind off 14 (14) [15] sts. 1x, 4 sts. 3x.
 Bring the needles on the left into working position, knit 1 row in Pattern to the left side, turn to Row Counter back to 244 (248) [250] and complete the left half. Follow the instructions from * and don't forget to complete the shoulder shaping.

SLEEVES: III

Cast on 66 (70) [70] sts. and work 24 rows K1, P1 Ribbing.
 Continue in Pattern.
 ON EACH SIDE, increase 1 st. every 8th row 16x (16x) [15x] and for last size only, ON EACH SIDE, increase 1 st. every 6th row 2x.
 After Row 166 SHAPE CAP: ON EACH SIDE bind off
 4 sts. 1x, 3 sts. 2x, 1 st. 20x, 2 sts. 6x.
 (4 sts. 1x, 3 sts. 2x, 1 st. 22x, 2 sts. 6x).
 [4 sts. 1x, 3 sts. 2x, 1 st. 21x, 2 sts. 7x].
 After Row 224 (228) [228], bind off the remaining sts.

dk 564



WOMAN'S TWO PIECE DRESS & SHOULDER BAG

SIZES: 10 (12)
YARN: Boucle

GRAMS:
color 1 800 850
color 2 250 250

TENSION: 8 to 10

GAUGE: 12 sts. 19 rows = 5 cm (2")

Stockinette stitch with stripes in 2nd color. Work on the purl side. The Bands are ribbed.

FINISHING: See General Instructions. TOP: Work 1 row single crochet around split opening then sew facing to the outside. Make a twisted cord and pull through neckband (see Picture). SHOULDER BAG: Fold bag in half and sew side seams. For STRAP: Cast on 24 sts. with color 2 and work stockinette stitch for 45". Fold in half and sew seam then sew to bag (See Picture).

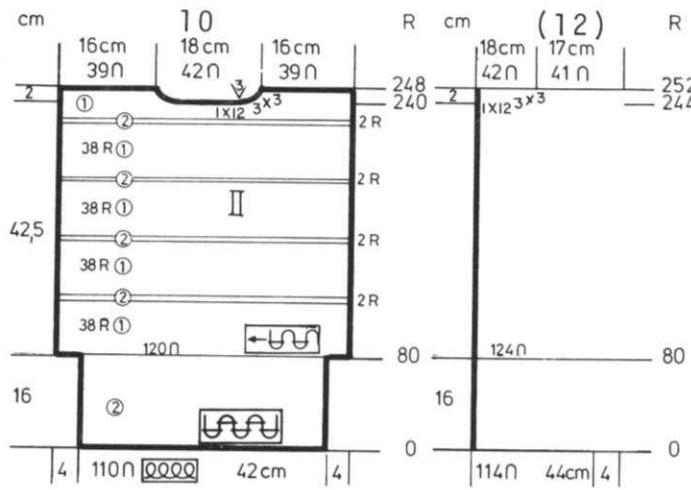

BLOUSE BACK: II

With Contrast waste yarn, cast on 120 sts. Knit 8 to 10 rows then beginning with color 1 and setting Counter at 80, work in Stockinette stitch with color stripes as shown on the Chart. Knit to Row 240 (244).

SHAPE NECK: Put half the sts. on the left into holding position and complete the right side first.

*ON NECK SIDE, bind off 12 sts. 1x, 3 sts. 3x for both sizes.

After Row 248 (252) bind off the remaining sts. Bring the needles on the left into working position, knit 1 row to the left side, turn the Row Counter back to 240 (244) and complete the left half. Follow the instructions from *.

Hang the open sts. of the cast on back onto the machine, decreasing to 110 sts. Transfer every other stitch to the Ribber and work 80 rows K1, P1 Ribbing then bind off the crochet method for Ribbing.

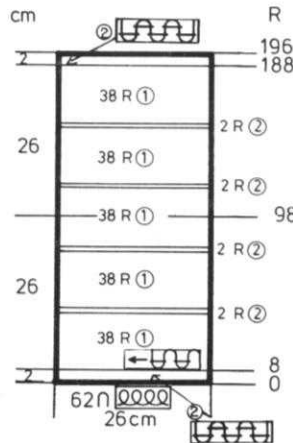

SHOULDER BAG:

With color 2 cast on 62 sts. and work 8 rows K1, P1 Ribbing. Continue in Stockinette stitch with color stripes as shown on the Chart. Knit to Row 188. Transfer every other stitch to the Ribber and with color 2, work 8 rows K1, P1 Ribbing. Bind off the crochet method for Ribbing.

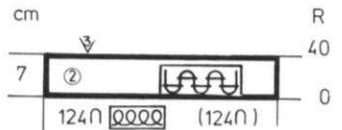

NECKBAND:

Cast on 124 sts. with color 2 and work 40 rows K1, P1 Ribbing then bind off the crochet method for Ribbing.

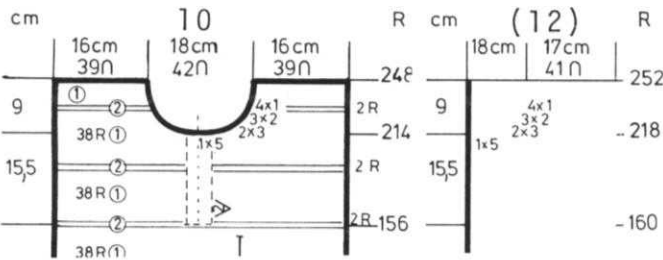

BLOUSE FRONT: I

Work the front the same as the back to Row 156 (160).

Divide in the center, put the needles on the left into holding position and complete the right side first.

*Knit to Row 214 (218).

SHAPE NECK: ON NECK SIDE, bind off 5 sts. 1x, 3 sts. 2x, 2 sts. 3x, 1 st. 4x for both sizes.

After Row 248 (252) bind off the remaining sts.

Bring the needles on the left into working position, knit 1 row to the left side, turn the Row Counter back to 156 (160) and complete the left half. Follow the instructions from *.

Hang the open sts. of the cast on back onto the machine as you did for the back and work the Ribbing the same.

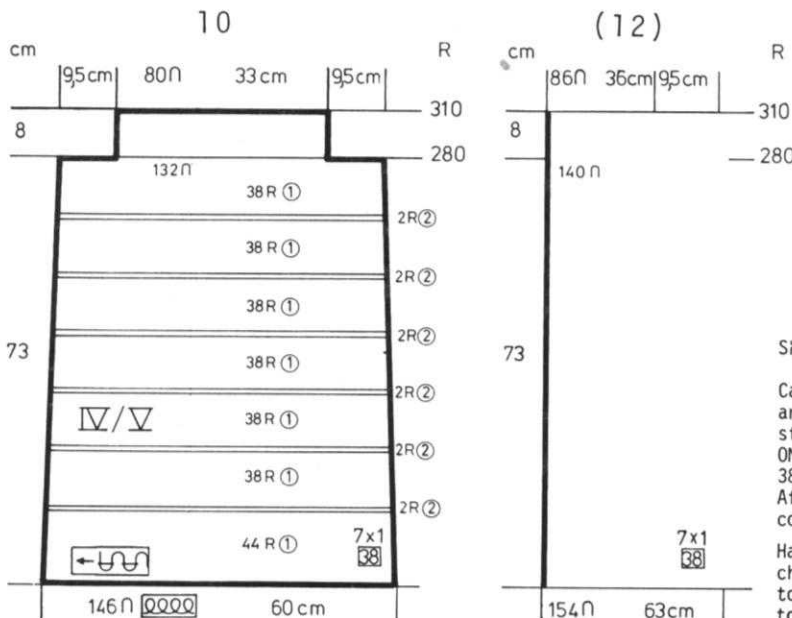

NECK OPENING BAND:

Cast on 46 sts. with color 2 and work Stockinette stitch. Knit 10 rows then work 1 row with contrast waste yarn over 38 sts. counting from the right. Continue with color 2 to row 20. Bind off. NOTE: You can begin this band with contrast waste yarn and remove it onto waste yarn. Slip stitch crochet around the edges then sew to neckline - makes a nicer edge.

SKIRT: Front and Back the same.

Cast on 146 (154) sts. with color 1 and work Stockinette stitch with color stripes as shown on the Chart.

ON EACH SIDE, decrease 1 st. every 38th row 7x for both sizes.

After Row 280, remove the sts. onto contrast waste yarn.

Hang the open sts. back onto the machine decreasing to 80 (86) sts. (2 sts. together 52x). Counter at 280. Knit to Row 310 then bind off loosely.

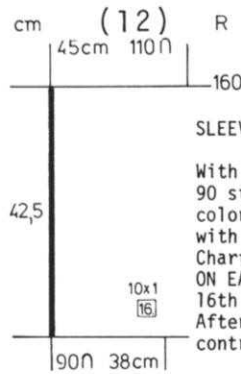
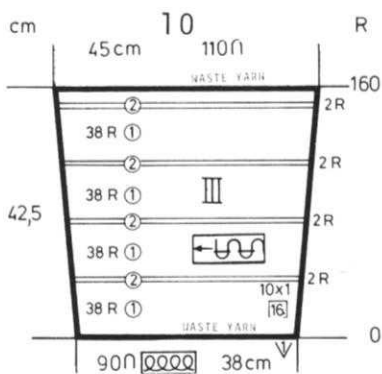

SLEEVES: III

With contrast waste yarn, cast on 90 sts. Knit 8 to 10 rows, change to color 1 and work Stockinette stitch with color stripes as shown on the Chart. Put Counter at 0. ON EACH SIDE, increase 1 st. every 16th row 10x for both sizes. After Row 160, remove the sts. onto contrast waste yarn.

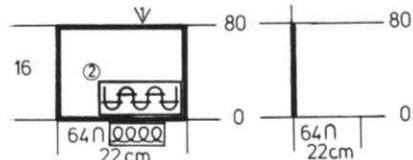

CUFFS:

Hang the open cast on sts. of the sleeve back onto the machine, decreasing 26 sts. evenly across (64 sts). Transfer every other stitch to the Ribber and work 80 rows K1, P1 Ribbing. Bind off the crochet method for Ribbing.

OK 565

WOMAN'S EYELET PULLOVER

SIZES: 8/10 (12/14)
YARN: Allegro
GRAMS: 550 600
TENSION: 9 or 10
GAUGE: 10 sts. 18 rows = 5 cm (2")



An Eyelet Design. Punch your own card or follow the Line Drawing. The sleeve cuffs and lower band are in K1, P1 Ribbing. The Collar and upper part of sleeves are Stockinette stitch.

FINISHING: See General Instructions.

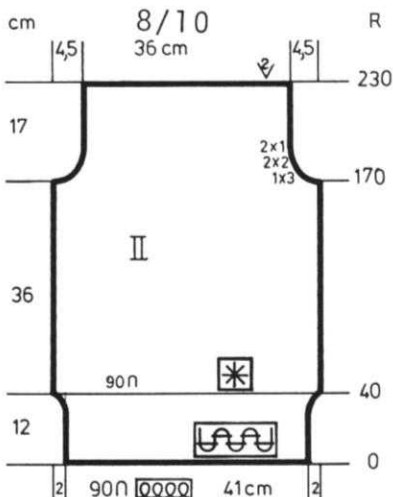

FRONT: I

Work the front the same as the back to Row 170. SHAPE ARMHOLE same as the back then knit to Row 210.

*SHAPE NECK: Put half the sts. on the left into holding position and complete the right side first. ON NECK SIDE, bind off 4 (5) sts. 1x, 3 sts. 2x, 2 sts. 2x, 1 st. 2x.

After Row 230 (232) bind off the remaining sts. Bring the needles on the left into working position, knit 1 row in Pattern to the left side, turn the Row Counter back to 210 and complete the left half. Follow the instructions from *.

SLEEVES: III Make 1, reverse 1.

Cast on 64 (70) sts. and work 40 rows K1, P1 Ribbing. Continue in the Eyelet Design. ON EACH SIDE, increase 1 st. every 28th row 4x for both sizes. After Row 154, SHAPE CAP: ON EACH SIDE, bind off 2 sts. 2x, 1 st. 21x. (3 sts. 1x, 2 sts. 1x, 1 st. 22x). After Row 200 (202) continue in Stockinette stitch. Knit to Row 229 (235). Bind off 11 (12) sts. then on every 2nd row, bind off 1 st. 5x. After Row 254 (260), bind off the remaining sts. Work the second sleeve with reverse shaping.

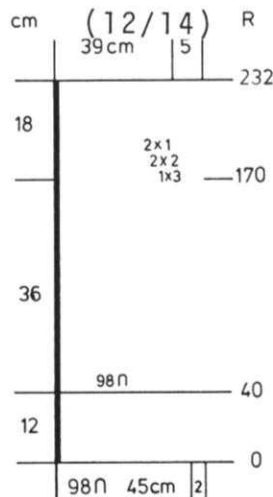

BACK: II

Cast on 90 (98) sts. and work 40 rows K1, P1 Ribbing. Continue in Eyelet Design. Knit to Row 170. SHAPE ARMHOLE: ON EACH SIDE, bind off 3 sts. 1x, 2 sts. 2x, 1 st. 2x for both sizes. After Row 230 (232), bind off the remaining sts.

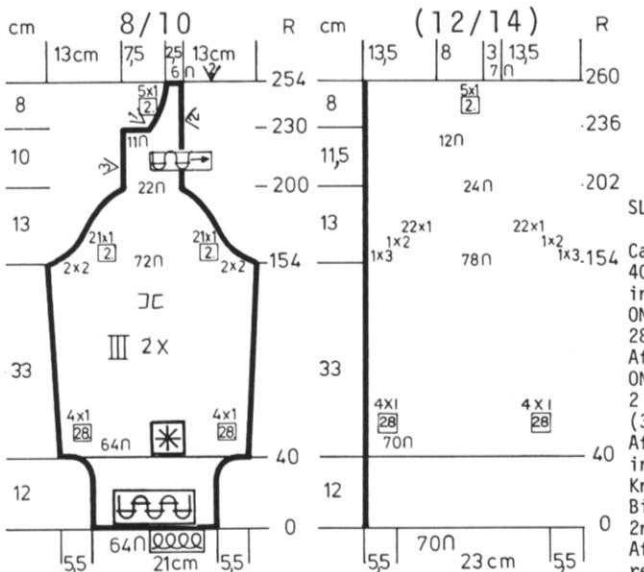
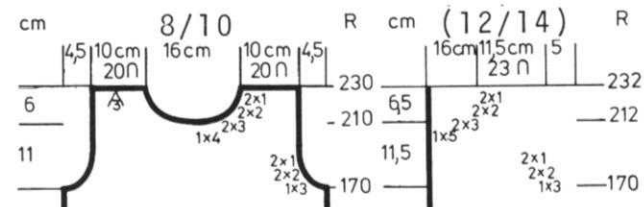

COLLAR: VI

Cast on 197 sts. and work 76 rows Stockinette stitch then bind off or you can remove onto waste yarn and back stitch the collar through the open sts. onto the neckline.

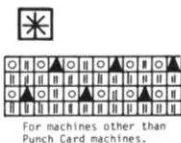

5-8 R
1-4, R

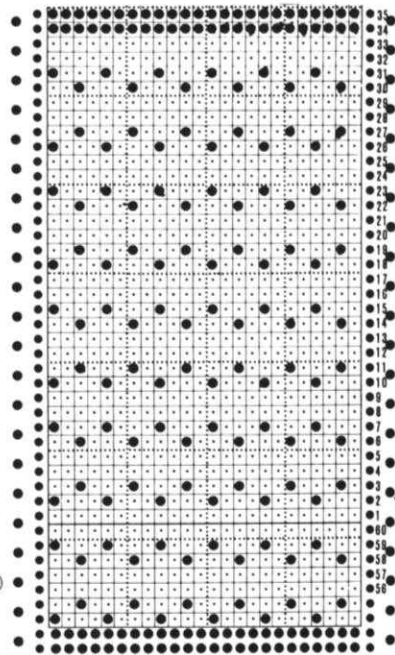

KNIT 4 ROWS BETWEEN LACE.

hp 566



MAN'S JACKET

SIZES: 38/40 (42/44)
 YARN: Euro Sport
 GRAMS: 1200 1300
 TENSION: 10 OVER EVERY OTHER NEEDLE
 GAUGE: 8 sts. 20 rows = 5 cm (2")

A Tuck stitch KNITTED OVER EVERY OTHER NEEDLE. The purl side is the right side. Punch your own card or follow the Line Drawing. Pocket bands are ribbed.

FINISHING: See General Instructions.

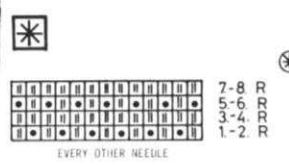
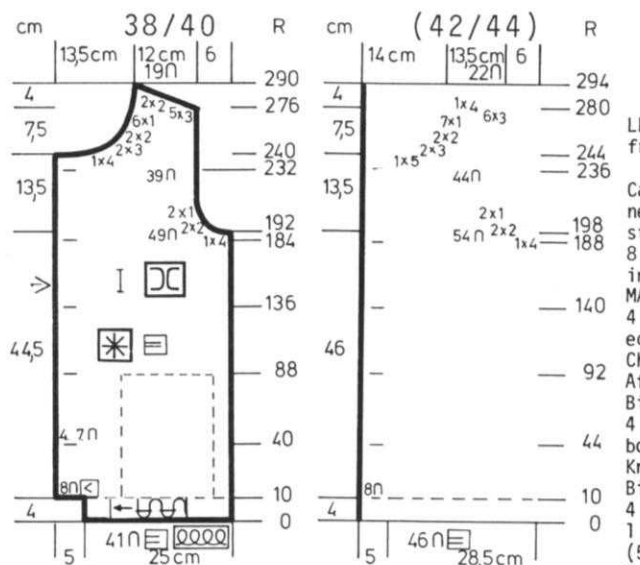
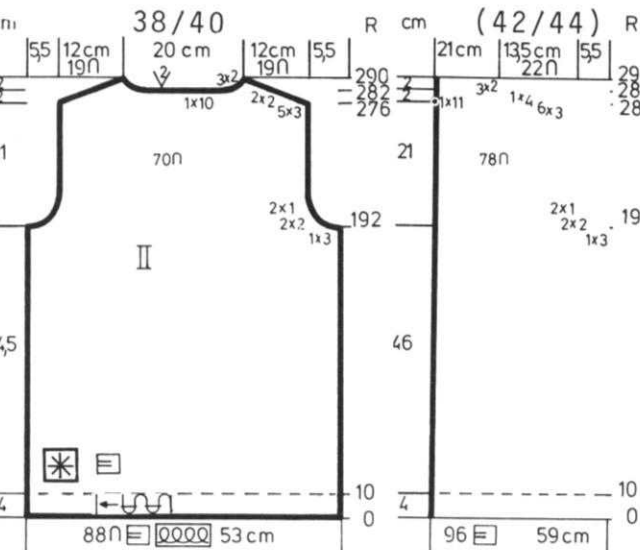
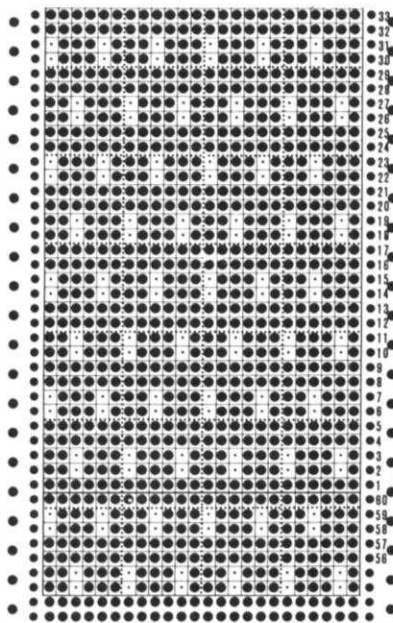

POCKETS: VII Make 2.

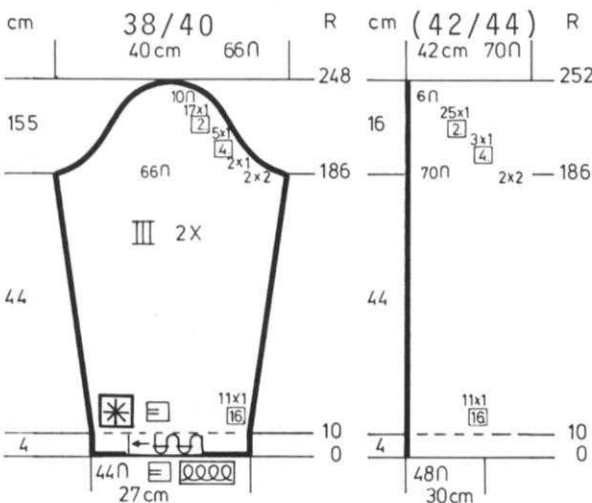

Cast on 26 sts. over every other needle and work 10 rows K1, P1 Ribbing. Continue in Pattern. to Row 68 then bind off.

SLEEVES: IIII

Cast on 44 (48) sts. over every other needle and work 10 rows Stockinette stitch. Continue in Pattern. ON EACH SIDE, increase 1 st. every 16th row 11x. Knit to Row 186. SHAPE CAP: ON EACH SIDE, bind off 2 sts. 2x, 1 st. 2x, then every 4th row 1 st. 5x, every 2nd row 1 st. 17x. (2 sts. 2x, then every 4th row 1 st. 3x, every 2nd row 1 st. 25x. After Row 248 (252) bind off the remaining sts.

BACK: II
 Cast on 88 (96) sts. over every other needle and knit 10 rows Stockinette stitch. Continue in Pattern. Knit to Row 192 (198). SHAPE ARMHOLE: ON EACH SIDE, bind off 3 sts. 1x, 2 sts. 2x, 1 st. 2x for both sizes. Knit to Row 276 (280). SHAPE SHOULDER and watch for NECK SHAPING. FOR SHOULDER: ON EACH SIDE, bind off 3 sts. 5x, 2 sts. 2x. (3 sts. 6x, 4 sts. 1x). FOR NECK: After Row 282 (286) put half the sts. on the left into holding position and complete the right side first. *ON NECK SIDE, bind off 10 (11) sts. 1x, 2 sts. 3x. Bring the needles on the left into working position, knit 1 row in Pattern to the left side, turn the Row Counter back to 282 (286) and complete the left half. Follow the instructions from * and don't forget to complete the shoulder shaping.

LEFT FRONT: I Reverse for right front and omit buttonholes.
 Cast on 41 (46) sts. over every other needle and work 10 rows Stockinette stitch. With a separate yarn, cast on 8 sts. on the left side then continue in Pattern. MAKE BUTTONHOLES over needles 4 to 7 counting from the left edge after the rows shown on the Chart. After Row 192 (198) SHAPE ARMHOLE: Bind off 4 sts. 1x, 2 sts. 2x, 1 st. 2x for both sizes. Knit to Row 239 (243). SHAPE NECK: Bind off 4 sts. 1x, 3 sts. 2x, 2 sts. 2x, 1 st. 6x. (5 sts. 1x, 3 sts. 2x, 2 sts. 2x, 1 st. 7x). SHAPE SHOULDER same as the back after Row 276 (280). Work the right front section with reverse shaping and omit the buttonholes.

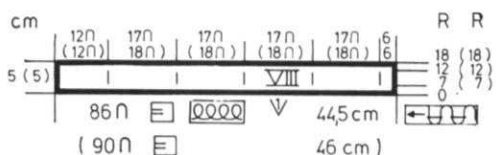

FRONT FACING: VIII Make 2 but omit the buttonholes in 2nd section.

You must make BUTTONHOLES vertically by knitting each section at a time for 6 rows.
 Cast on 86 (90) sts. over every other needle and work Stockinette stitch. Knit to Row 6. Put all but the first 6 needles on the right into holding position. Knit 6 rows. Put these 6 sts. into holding, bring the next 17 (18) sts. into work, knit 6 rows. Put these sts. into holding, bring the next 17 (18) sts. into work, knit 6 rows. etc. etc. continuing across the needles until all have been knitted. Now bring all the needles into working position, put Counter at 12 and knit to Row 18. Bind off.

KK 567



BOY'S PULLOVER

SIZES: 8/10 (12) [14]
 YARN: Fortissima
 GRAMS: 400 450 500
 TENSION: 9 or 10
 GAUGE: 13 sts. 18 rows = 5 cm (2")

A Ribbing Pattern on the front section only. 6 sts. on main machine, 6 sts. on Ribber and after every 10 rows, reverse the stitches.

FINISHING: See General Instructions.

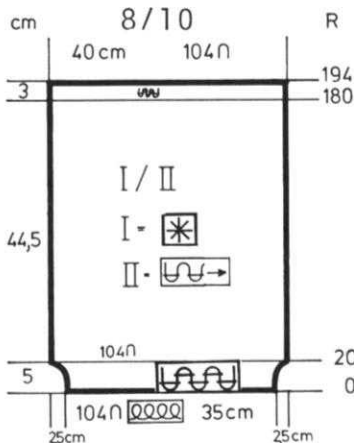

FOR THE FRONT SECTION ONLY. Always leave 6 sts. at EACH END on the main machine (purl st.). After every 10 rows, transfer the ribber sts. to main machine and the main machine sts. to the Ribber.

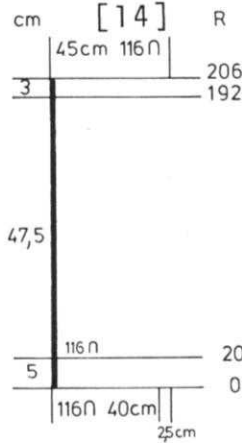
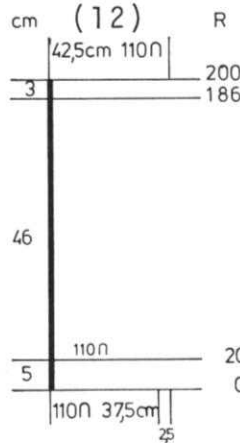

FRONT: I

Cast on 104 (110) [116] sts. and work 20 rows K1, P1 Ribbing. Continue in Pattern. Knit to Row 180 (186) [192]. Transfer the necessary sts. and work K1, P1 Ribbing to Row 194 (200) [206]. Bind off.

BACK: Work the back the same as the front except work Stockinette stitch instead of Pattern.

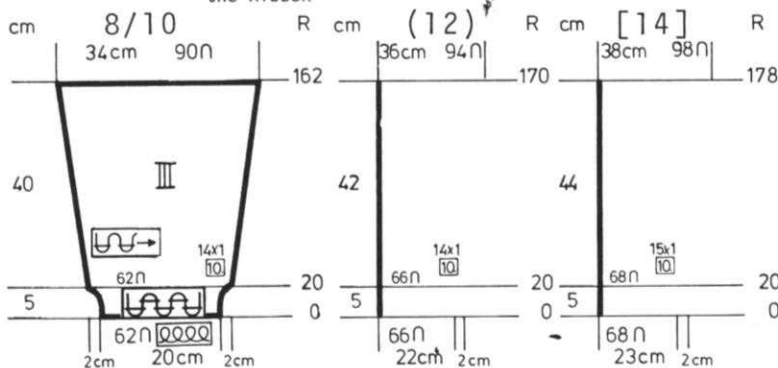

SLEEVES: III

Cast on 62 (66) [68] sts. and work 20 rows K1, P1 Ribbing. Continue in Stockinette stitch. ON EACH SIDE, increase 1 st. every 10th row 14x (14x) [15x]. After Row 162 (170) [178], bind off the remaining sts.



KK 568

WOMAN'S LONG PULLOVER, LEGWARMERS, CAP & MITTENS

SIZE: 8 to 10
 YARN: Knitting worsted weight yarn
 GRAMS: color 1 1200, color 2 150, color 3 300
 TENSION: 10 OVER EVERY OTHER NEEDLE
 GAUGE: 9 sts. 12 rows = 5 cm (2")

Stockinette stitch and Ribbing with color stripes on the Legwarmers and Cap. Embroidered Flowers on front and pockets.

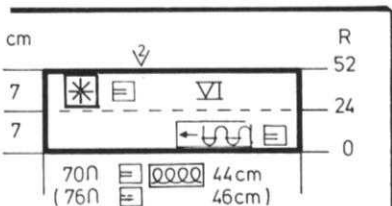

COLLAR: VI

Cast on 70 (76) sts. over every other needle and work Stockinette stitch to Row 24, then continue in Pattern to Row 52. Bind off.

FINISHING: See General Instructions. PULLOVER: Sew pockets in place. Make a twisted cord and pull through eyelets at waist. Embroider Flowers on front and pockets as shown in picture. LEGWARMERS: Sew back seam. CAP: Sew back seam and pull up the sts. and secure. MITTENS: Sew seam and pull up the sts. and secure.

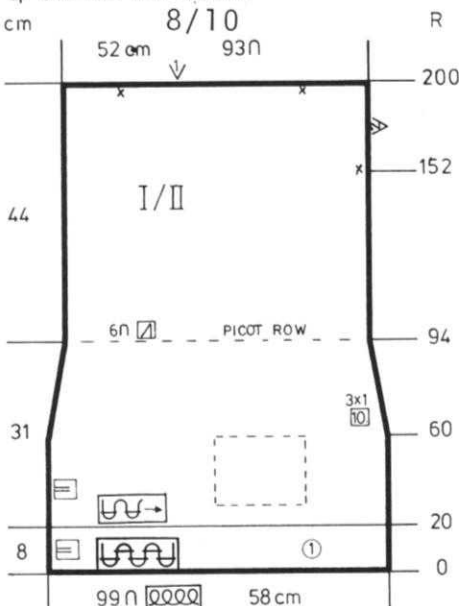

FRONT & BACK: I/II Two sections the same. USE EVERY OTHER NEEDLE THROUGHOUT.

Cast on 99 sts. with color 1 and work 20 rows K1, P1 Ribbing. Continue in Stockinette stitch. Knit to Row 60. ON EACH SIDE, decrease 1 st. every 10th row 3x. Knit to Row 94. MAKE EYELETS ACROSS by hanging every 6th sts. onto the 7th st. and leave empty needles in work. Knit to Row 152. Mark each side for setting in sleeve. Knit to Row 200 then bind off loosely.

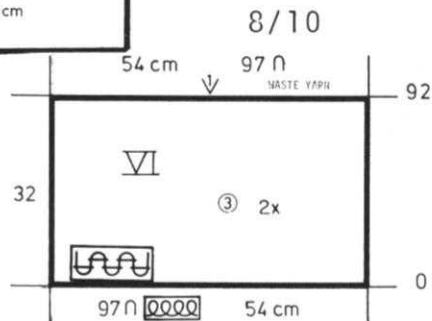

COLLAR: Make 2 sections - OVER EVERY OTHER NEEDLE.

Cast on 97 sts. with color 3 and work 92 rows K1, P1 Ribbing then bind off the crochet method for ribbing very loosely, or you may remove the sts. onto contrast waste yarn and back stitch the open sts. to the neckline of Pullover.

dk 568

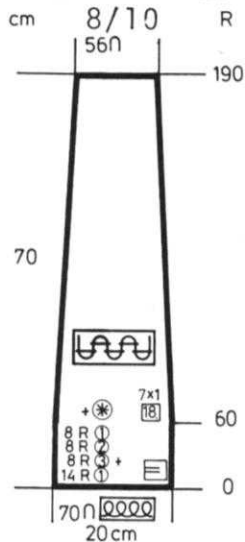

LEGWARMERS: Make 2 - OVER EVERY OTHER NEEDLE.

Cast on 70 sts. with color 1 and work K1, P1 Ribbing with REPEATED color stripes as shown on the Chart. After Row 60, ON EACH SIDE, decrease 1 st. every 18th row 7x. After Row 190, bind off loosely.

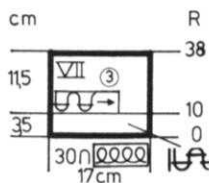

POCKETS: Make 2 OVER EVERY OTHER NEEDLE.

Cast on 30 sts. with color 1 and work 10 rows K1, P1 Ribbing. Continue in Stockinette stitch to Row 38. Bind off.

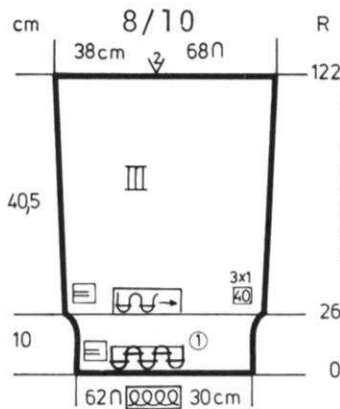

SLEEVES: EVERY OTHER NEEDLE

Cast on 62 sts. with color 1 and work 26 rows K1, P1 Ribbing. Continue in Stockinette stitch. ON EACH SIDE, increase 1 st. every 40th row 3x. After Row 122. bind off loosely.

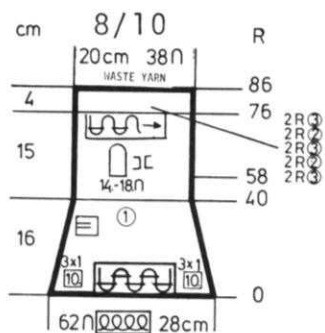

MITTENS: Make 2 - OVER EVERY OTHER NEEDLE.

With color 1, cast on 62 sts. and work K1, P1 Ribbing. ON EACH SIDE, decrease 1 st. every 10th row 3x. After Row 40, continue in Stockinette stitch. After Row 58, knit the 14th to 18th sts. counting from the left (right for 2nd mitten) edge with waste yarn and continue with color 1 to Row 76. Work the color stripes as shown on the Chart. After Row 86, take the sts. off onto a double strand of yarn.

THUMB: Use double pointed hand knitting needles and pick up the sts. held on waste yarn- 10 sts. Put 3, 3, 4 on 3 needles then knit 12 rounds. Go through the sts. with double yarn, pull up and tie tightly.

CAP: EVERY OTHER NEEDLE

Cast on 79 sts. with color 1 and work K1, P1 Ribbing with color stripes as shown next to the Chart, then continue with color 1.

After Row 72, hang the center stitch on the neighboring needle and transfer the left side ribber sts. to the main machine then put them into holding position. *Over the remaining sts. ON EACH SIDE, decrease 1 st. every 4th row 4x. After Row 90, remove the sts. onto a double strand of yarn.**

Move the Cam Box to the left side, transfer the proper rib sts. back to the ribber and put Counter at 72. REPEAT from * to **.

np 569



MAN'S SLEEVELESS PULLOVER

SIZES: 34/36 (38/40) [42/44]
YARN: Euro Sport
GRAMS:
 color 1 300 350 400
 color 2 50 50 50
 color 3 50 50 50
TENSION: 10
GAUGE: 12 sts., 17 rows = 5 cm (2")

Stockinette stitch with color stripes as shown on the Chart. Bands are K1, P1 Ribbing.

FINISHING: See General Instructions.

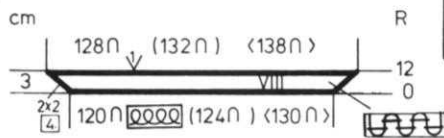

ARMHOLE BANDS Make 2.

Cast on 120 (124) [130] sts. with color 1 and work K1, P1 Ribbing. ON EACH SIDE, increase 2 sts. every 4th row 2x. After Row 12, bind off the crochet method for Ribbing.

BACK: II

Cast on 116 (126) [138] sts. with color 1 and work 30 rows K1, P1 Ribbing. Continue in Stockinette stitch with color stripes as shown on the Chart. ON EACH SIDE, increase 1 st. every 30th row 2x. Knit to Row 146 (152) [152]. **SHAPE ARMHOLE:** ON EACH SIDE, bind off 4 sts. 1x, 3 sts. 2x, 2 sts. 2x, 1 st. 3x. (same as first size). [5 sts. 1x, 3 sts. 3x, 2 sts. 2x, 1 st. 3x]. Knit to Row 220 (228) [228]. **SHAPE NECK** and watch for **SHOULDER SHAPING:** Put half the sts. on the left into holding position and complete the right side first. *ON NECK SIDE, bind off 12 (14) [14] sts. 1x, 4 sts. 3x. FOR SHOULDER, After Row 224 (232) [232], bind off 6 sts. 2x, 7 sts. 1x. (7 sts. 2x, 8 sts. 1x). [8 sts. 3x]. Move the Cam Box to the left side, turn the Row Counter back to 220 (228) [228] and complete the left half. Follow the instructions from *.

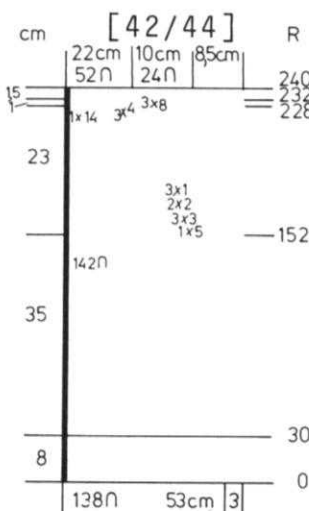
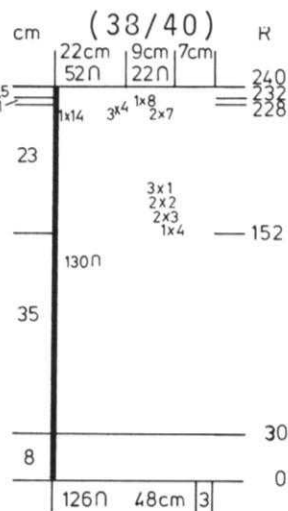
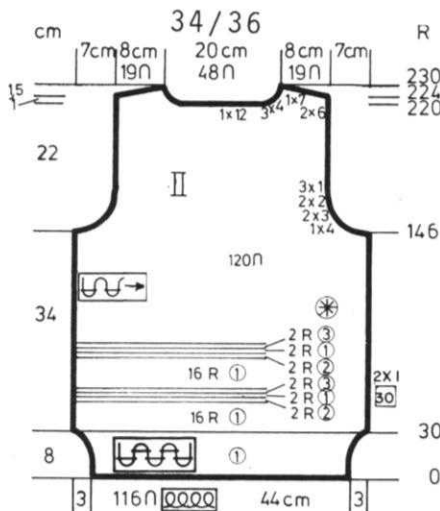

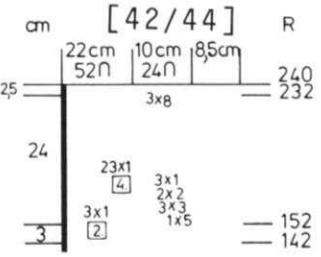
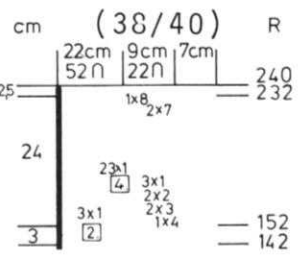
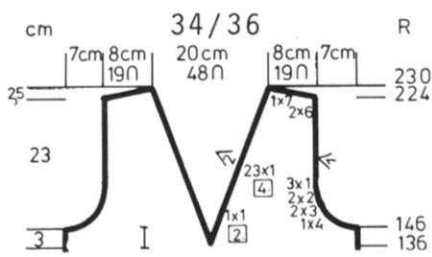

FRONT: I
 Work the front the same as the back to Row 136 (142) [142]. Divide in the center, put half the sts. on the left into holding position and complete the right side first.
 *ON NECK SIDE, decrease 1 st. every 2nd row 1x (3x) [3x], every 4th row 23x AND AT THE SAME TIME, SHAPE ARMHOLE same as the back after Row 146 (152) [152] and SHAPE SHOULDER same as the back after Row 224 (232) [232].
 Move the Cam Box to the left side, turn the Row Counter back to 136 (142) [142] and complete the left half. Follow the instructions from *.

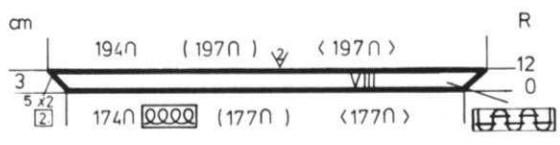

NECKBAND: VIII
 Cast on 174 (177) [177] sts. with color 1 and work K1, P1 Ribbing. ON EACH SIDE, increase 2 sts. every 2nd row 5x. After Row 12, bind off the crochet method for Ribbing.

dk 570



WOMAN'S VEST
 SIZES: 7/8 (10/12) [14]
 YARN: Euro Sport
 GRAMS:
 color 1 300 350 400
 color 2 50 50 50
 color 3 50 50 50
 TENSION: 10
 GAUGE: 12 sts. 17 rows = 5 cm (2")

Stockinette stitch with color stripes as shown on the Chart. Bands are K1, P1 Ribbing.

FINISHING: See General Instructions. For 3rd size only - Ease the extra rows of front section at the bustline.

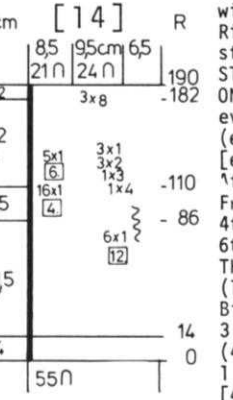
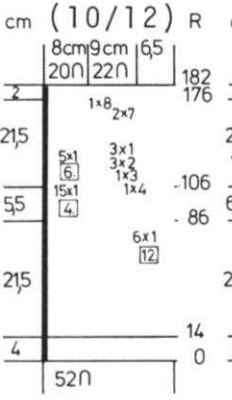
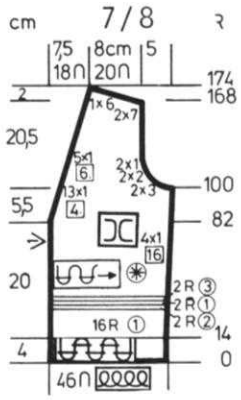

FRONT: I
 Cast on 46 (52) [55] sts. with color 1 and work 14 rows K1, P1 Ribbing. Continue in Stockinette stitch with the REPEATED COLOR STRIPES as shown on the Chart. ON SIDE EDGE, increase 1 st. every 16th row 4x. (every 12th row 6x). [every 12th row 6x]. After Row 82 (86) [86], SHAPE FRONT: Decrease 1 st. every 4th row 13x (15x) [16x], every 6th row 5x for all sizes. AND AT THE SAME TIME, after Row 100 (106) [110], SHAPE ARMHOLE: Bind off 3 sts. 2x, 2 sts. 2x, 1 st. 2x. (4 sts. 1x, 3 sts. 1x, 2 sts. 3x, 1 st. 3x). [4 sts. 1x, 3 sts. 1x, 2 sts. 3x, 1 st. 3x]. After Row 168 (176) [182], SHAPE SHOULDER same as the back.

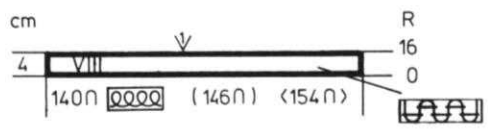

LEFT FRONT BAND: VIII
 Cast on 140 (146) [154] sts. with color 1 and work 16 rows K1, P1 Ribbing. Bind off the crochet method for Ribbing.

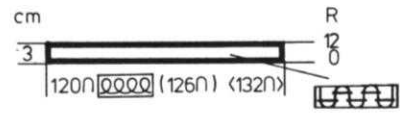

ARMBANDS: Make 2.
 Cast on 120 (126) [132] sts. with color 1 and work 12 rows K1, P1 Ribbing. Bind off the crochet method for Ribbing.

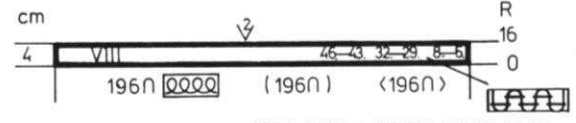

NECK BAND & RIGHT FRONT BAND:
 Cast on 196 sts. and work K1, P1 Ribbing. After Row 8, make BUTTONHOLES over needles 5 to 8, 29 to 32, 43 to 46 counting from the right edge. After Row 16, bind off the crochet method for Ribbing.

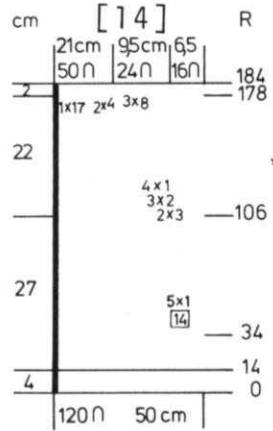
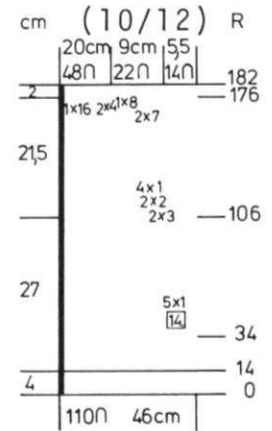
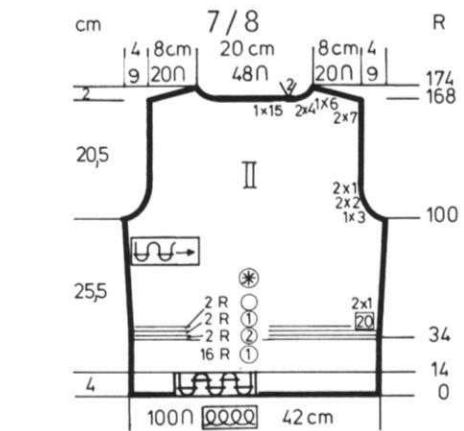

BACK: II
 Cast on 100 (110) [120] sts. with color 1 and work 14 rows K1, P1 Ribbing. Continue in Stockinette stitch with color stripes as shown on the Chart. ON EACH SIDE, increase 1 st. every 20th row 2x (every 14th row 5x) [every 14th row 5x]. Knit to Row 100 (106) [106]. SHAPE ARMHOLE: ON EACH SIDE, bind off 3 sts. 1x, 2 sts. 2x, 1 st. 2x. (3 sts. 2x, 2 sts. 2x, 1 st. 4x). [3 sts. 2x, 2 sts. 3x, 1 st. 4x]. Knit to Row 168 (176) [178]. SHAPE SHOULDERS AND NECK AT THE SAME TIME. Put half the sts. on the left into holding position and complete the right side first. *FOR SHOULDER, bind off 7 sts. 2x, 6 sts. 1x. (7 sts. 2x, 8 sts. 1x). [8 sts. 3x]. FOR NECK: Bind off 15 (16) [17] sts. 1x, 4 sts. 2x. Bring the needles on the left into working position, knit 1 row in Pattern to the left side, turn the Row Counter back to 168 (176) [178] and complete the left half. Follow the instructions from *.

dk 571

WOMAN'S JACKET

SIZES: 8/10 (12/14)
 YARN: Color 1 = Allegro
 Color 2 = Binia
 GRAMS: color 1 700 750
 color 2 300 300
 TENSION: 8 or 9
 GAUGE: 12 sts. 19 rows = 5 cm (2")
 4 yards Fur Trim.



A Weaving Design. Punch your own Card or 830 Machine owners use Standard Card 2D. AM 3 machine owners, use Wheel No. 6.

FINISHING: See General Instructions. Work 1 row single crochet around pocket openings then sew in pockets and work 2 more rows single crochet across front openings of pockets. Weave the sleeves to the open arm-hole sts.

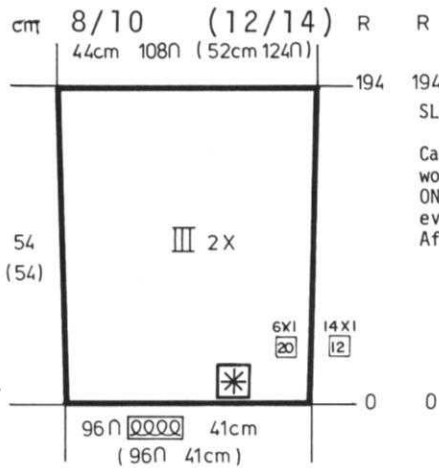

SLEEVES: III

Cast on 96 sts. and work in Pattern.
 ON EACH SIDE, increase 1 st. every 20th row 6x (12th row 14x). After Row 194, bind off.

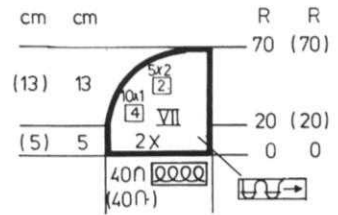

POCKET: VII Make 1, reverse 1.

Cast on 40 sts. and work in Stockinette stitch.
 After Row 19, decrease 1 st. every 4th row 10x, then bind off 2 sts. 5x.
 After Row 70, bind off.

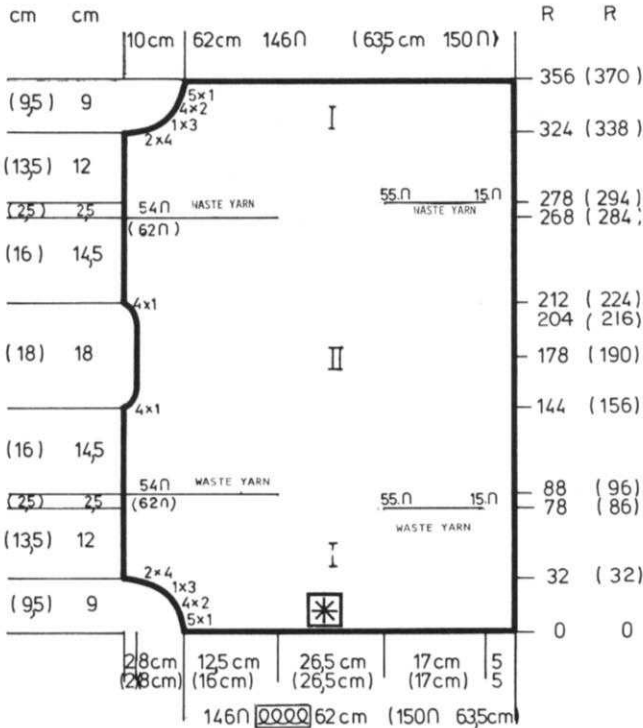
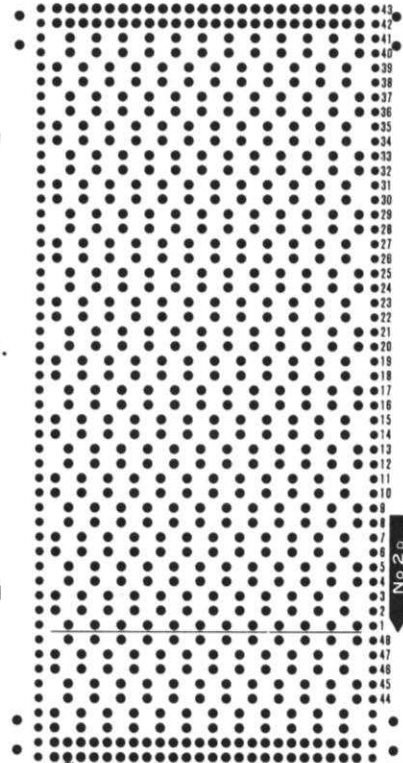

FRONT & BACK:

Cast on 146 (150) sts. and work in Pattern.
 ON THE LEFT SIDE, on every 2nd row, cast on 1 st. 5x, 2 sts. 4x, 3 sts. 1x, 4 sts. 2x.
 After Row 78 (86) counting from the RIGHT edge and using waste yarn, knit the 15th to 55th sts. by hand. Leave the sts. in work.
 After Row 88 (96) on the LEFT side, and using waste yarn, knit the first 54 (62) sts. by hand as you did before and leave the sts. in work.
 Knit to Row 143 (155).
 SHAPE NECK: bind off 1 st. 4x.
 After Row 178 (190) mark each side for center.
 Knit to Row 203 (215). SHAPE NECK: Cast on 1 st. 4x.
 Knit to Row 268 (284).
 ON THE LEFT, knit the first 54 (62) sts. with waste yarn as you did before.
 After Row 278 (294) ON THE RIGHT, knit the 15th to 55th sts. with waste yarn as you did before.
 Knit to Row 323 (337).
 SHAPE NECK: Bind off 4 sts. 2x, 3 sts. 1x, 2 sts. 4x, 1 st. 5x.
 After Row 356 (370), bind off the remaining sts.

*Knit 2 rows PLAIN
 Weave 1 row
 REPEAT FROM *

dk 572

WOMAN'S JACKET & SKIRT

SIZES: 8/10 (12/14)
 YARN: Allegro
 GRAMS: 750 800
 TENSION: 6 to 8
 GAUGE: 13 1/2 sts. 21 rows = 5 cm

Stockinette stitch worn on the Purl side. Knitted sideways on the machine.

FINISHING: JACKET: Weave front and back together at shoulders and down sleeves. Slip stitch open sts. of Collar to neck. Slip stitch crochet cuff to bottom of sleeves. Hem front facing and finish Buttonholes. Weave waistbands together then slip stitch to bottom of Jacket easing to fit - double up where necessary.
 SKIRT: Weave the open sts. held on waste yarn. Make pleats on front. Turn under hem.

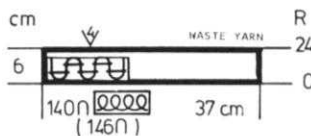

NECKBAND:

Cast on 140 (146) sts. and work 24 rows K1, P1 Ribbing. Remove the sts. onto contrast waste yarn.

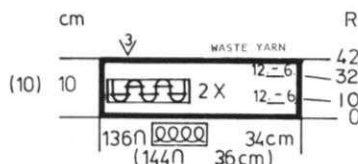

WAISTBAND: Make 2 but omit the BUTTONHOLES in 2nd section.

Cast on 136 (144) sts. and work K1, P1 Ribbing.
 After Row 10 and 32, make BUTTONHOLES over needles 6 to 12 counting from the RIGHT EDGE. After Row 42, remove the sts. onto contrast waste yarn.

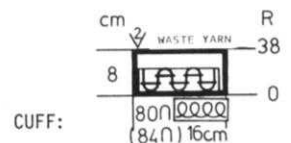

CUFF:

Cast on 80 (84) sts. and work 38 Rows K1, P1 Ribbing. Remove the sts. onto contrast waste yarn.

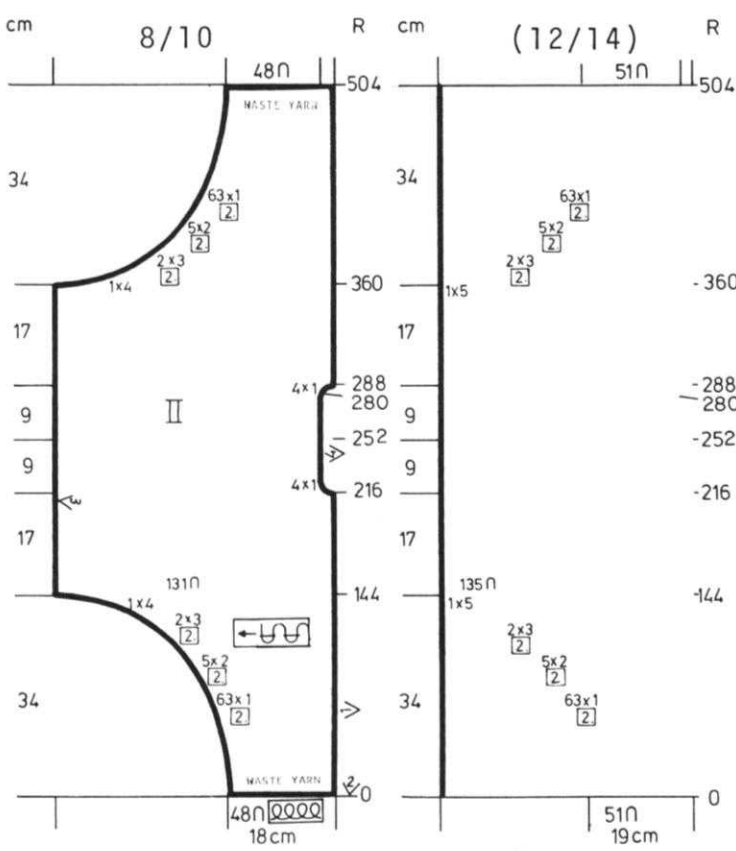

JACKET BACK: II

With contrast waste yarn, cast on 48 (51) sts. Knit 8 to 10 rows, then continue with garment yarn and put COUNTER AT 0. ON THE LEFT SIDE, on every 2nd row, cast on 1 st. 63x, 2 sts. 5x, 3 sts. 2x, then cast on 4(5) sts. Knit to Row 216. SHAPE NECK: Bind off 1 st. 4x. Mark Row 252 ON EACH SIDE for center neck and waist. Knit to Row 280, cast on 1 st. 4x. Knit to Row 360. ON THE LEFT, bind off 4 (5) sts. then every 2nd row, bind off 3 sts. 2x, 2 sts. 5x, 1 st. 63x. After Row 504, remove the sts. onto contrast waste yarn.



JACKET RIGHT FRONT: I Make 1. Reverse 1 for left front and omit the Buttonholes.

With contrast waste yarn, cast on 48 (51) sts. Knit 8 to 10 rows, change to garment yarn and put Counter at 0. Continue in Stockinette stitch. ON EVERY 2nd row, cast on 1 st. 63x, 2 sts. 5x, 3 sts. 2x, then cast on 4 (5) sts. 1x.

Knit to Row 215. ON NECK SIDE, bind off 4 sts. 1x, 3 sts. 4x, 2 sts. 2x, 1 st. 4x, and after Row 250, MAKE BUTTONHOLES over needles 5 to 10, 34 to 39, 63 to 68, 92 to 97 counting from the LEFT edge. REPEAT the BUTTONHOLES over the same needles after Row 270. After Row 282, bind off.

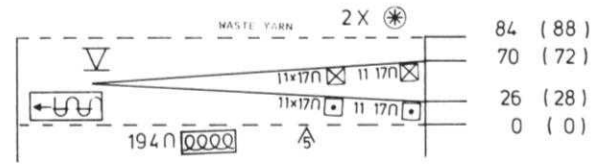
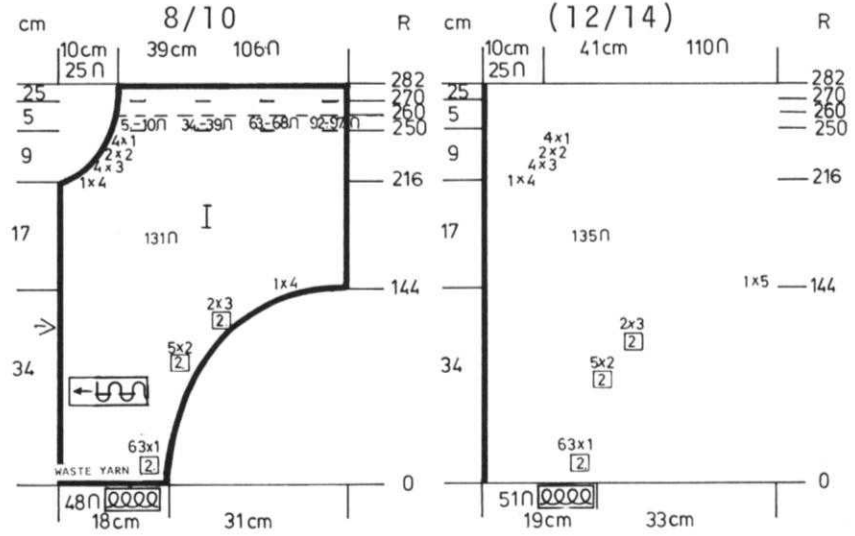
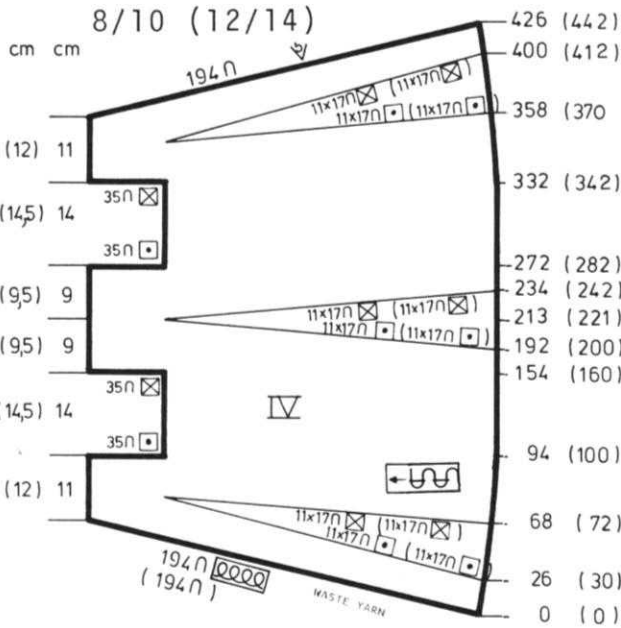

SKIRT: FRONT & BACK: After knitting the front of skirt, turn the Row Counter to 0 and continue with back section.

With contrast waste yarn, cast on 194 sts. Knit 8 to 10 rows then change to garment yarn and put counter at 0.

Knit to Row 26 (30) then WORK SHORT ROWS: * ON OPPOSITE SIDE OF CAM BOX, put into holding position, 17 sts. 11x. ON OPPOSITE SIDE OF CAM, bring back into working position 17 sts. 11x. ** Knit to Row 94 (100). ON OPPOSITE SIDE OF CAM BOX, put 35 sts. into holding position. Knit to Row 154 (160) Bring all the needles into working position and knit to Row 192 (200). WORK THE SHORT ROWS from * to ** and MARK each end for center after Row 213 (221). Knit to Row 272 (282). ON OPPOSITE SIDE OF CAM BOX put 35 sts.

into holding position. Knit to Row 332 (342) then bring these needles back into working position. Knit to Row 358 (370). WORK THE SHORT ROWS from * to **. Knit to Row 426 (442). Put ROW COUNTER AT 0 and continue with BACK. Knit to Row 26. WORK THE SHORT ROWS FROM * to ** as on the front. Knit to Row 84 (88). PUT COUNTER AT 0 AND REPEAT THIS SECTION 2 TIMES MORE. Remove the Sts. onto contrast waste yarn.

dk 573



WOMAN'S PULLOVER AND NECKLACE BAG

SIZES: 8/10 (12/14)
 YARN: Color 1 = Beatrice Silver
 Color 2 = Capriccio
 GRAMS: color 1 400 450
 color 2 25 25
 TENSION: 6 to 8
 GAUGE: 14 sts. 19 rows = 5 cm (2")

Stockinette stitch worn on the Purl side. Knitted sideways on the machine.

FINISHING: See General Instructions. Work the following crochet around lower edge, neckline and sleeves.
 Row 1 - Single Crochet
 Row 2 -*1 double crochet, chain 1, skip 1 sc. REPEAT from *.
 Row 3 -*1 double crochet in dc of row below, 2 dc in ch 1 of row below. REPEAT from *
 Make 9 strand twisted cord (Monks Cord) for Belt. Make twisted cord for bag. See Practical Knitting Hints this issue.

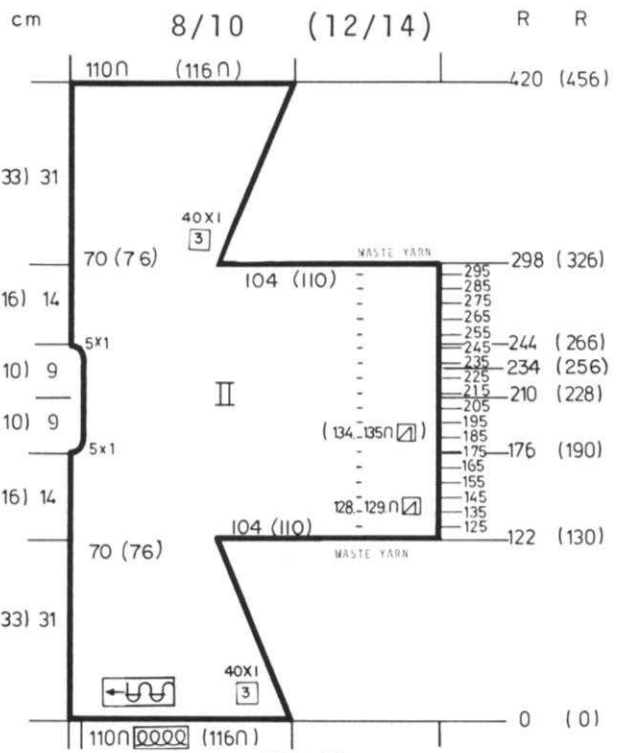
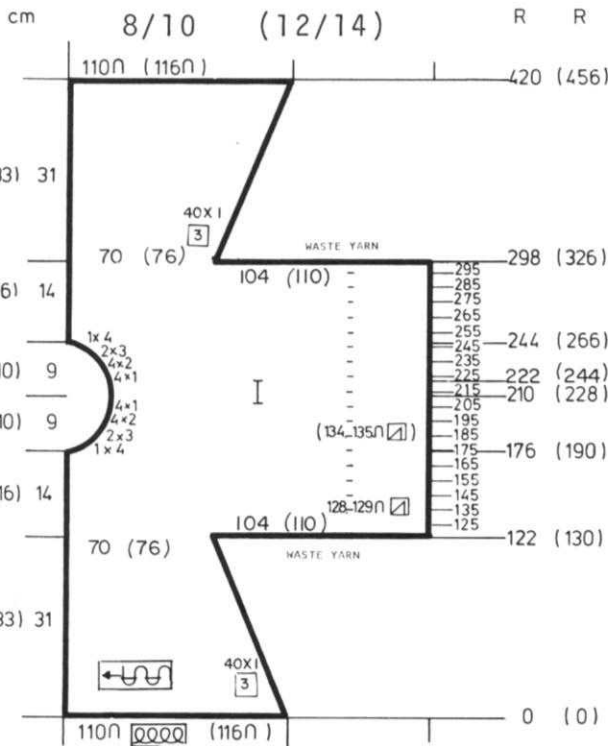

FRONT: I

Cast on 110 (116) sts. to the left side of machine.
 ON EVERY 3rd ROW, decrease 1 st. 40x.
 After Row 122 (130) with contrast waste yarn, cast on 104 (110) sts. MAKE EYELETS by hanging the 128th st. onto the 129th st. counting from the LEFT after the odd rows shown on the Chart.
 After Row 175 (189) SHAPE NECK: Bind off 4 sts. 1x, 3 sts. 2x, 2 sts. 4x, 1 st. 4x.
 Mark Row 210 (228) ON EACH SIDE for center.
 After Row 221 (243) ON NECK SIDE, cast on 1 st. 4x, 2 sts. 4x, 3 sts. 2x, 4 sts. 1x.
 After Row 298 (326), remove 104 (110) sts. onto contrast waste yarn.
 ON EVERY 3rd row, increase 1 st. 40x.
 After Row 420 (456), bind off.

BACK: II

Work the back the same as the front with the exception of the neck shaping.
 After Row 175 (189), SHAPE NECK: Bind off 1 st. 5x.
 Mark each side after Row 210 (228) for center.
 After Row 233 (255) cast on 1 st. 5x. etc. etc.

BAG: With double strand of Capriccio cast on 30 sts. Knit 6 cm (2 1/2") Stockinette stitch. Drop on contrast waste yarn. Fold in half and sew up side. Finish top with 1 row single crochet, 1 row double crochet. REPEAT 1 row single crochet then work 1 row reverse single crochet. Make 8 fringes on bottom of bag. Make twisted cord and attach (see picture).

dk 574

WOMAN'S BOLERO JACKET

SIZES: 8/10 (12/14)
 YARN: Fortissima
 GRAMS: 250 300
 TENSION: 8 to 10
 GAUGE: 15 1/2 sts. 17 rows = 5 cm (2")
 8 Buttons, 4 yds. Braid, 3 double chains.

Punch your own Card and set machine for Norwegian technique. The same color is placed in each feeder.

FINISHING: See General Instructions. Sew on Braid around all edges. Sew on Buttons and attach chains to right side (see picture).

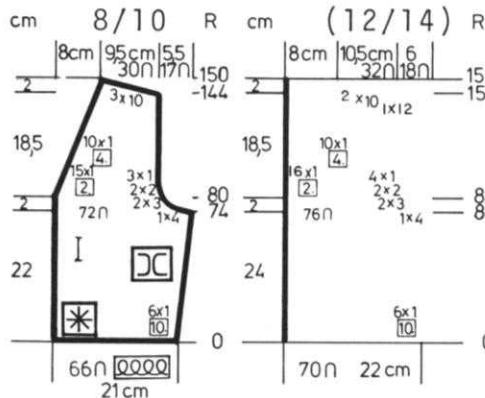

FRONT: Make 1, reverse 1.

Cast on 66 (70) sts. and work in Pattern. ON SIDE EDGE, increase 1 st. every 10th row 6x.
 After Row 74 (80), SHAPE ARMHOLE same as the back, BUT AT THE SAME TIME after Row 80 (86) SHAPE FRONT EDGE.
 Decrease 1 st. every 2nd row 15x (16x) then every 4th row 1 st. 10x.
 After Row 144 (150), SHAPE SHOULDER same as the back.

Revers

REVERS: Make 1, reverse 1.

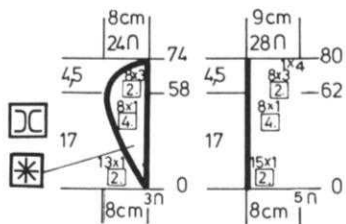

Cast on 3 (5) sts. and work in Pattern.
ON THE LEFT(right for 2nd section), increase 1 st. every 2nd row 13x (15x), then increase 1 st. every 4th row 8x.
After Row 58 (62) ON THE LEFT, bind off 3 sts. every 2nd row 8x (8x) and for 2nd size only, 4 sts. 1x.

BACK: II

Cast on 132 (138) sts. and work in Pattern.
ON EACH SIDE, increase 1 st. every 10th row 6x.
After Row 74 (80), SHAPE ARMHOLES: ON EACH SIDE, bind off 4 sts. 1x, 3 sts. 2x, 2 sts. 2x, 1 st. 3x.
(4 sts. 1x, 3 sts. 2x, 2 sts. 2x, 1 st. 4x).
Knit to Row 144 (150).
SHAPE SHOULDER AND NECK AT THE SAME TIME.

Put half the sts. on the left into holding position and complete the right side first.
*FOR SHOULDER, bind off 10 sts. 3x.
(12 sts. 1x, 10 sts. 2x).
FOR NECK, bind off 15 sts. 1x, 5 sts. 2x for both sides.
Bring the needles on the left into working position, knit 1 row in Pattern to the left side, turn the Row Counter back to 144 (150) and complete the left half. Follow the instructions from *.

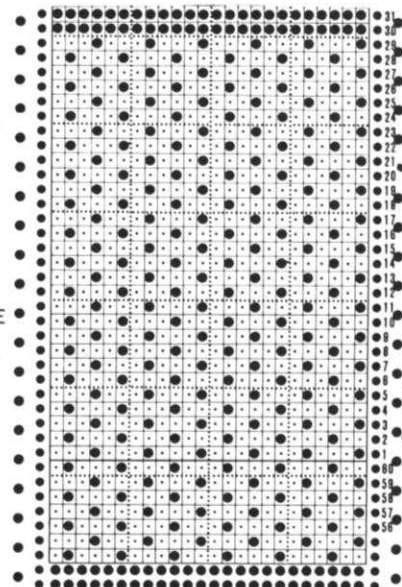
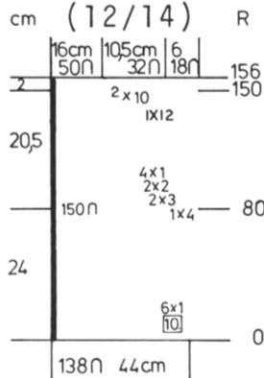
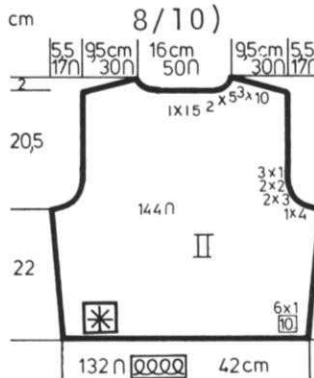

NORWEGIAN TECHNIQUE
SAME YARN IN BOTH FEEDERS.

DK 575

WOMAN'S JACKET

SIZES: 8/10 (12/14)
YARN: Euro Sport
GRAMS: 600 650
TENSION: 10
GAUGE:
Pat: 10 sts. 24 rows = 5 cm (2")
Stock: 12 sts. 16 rows = 5 cm (2")
6 Buttons. Green & Red Yarn for Embroidery.

A Tuck Stitch. Punch Card machine 820,830 owners, Card No.1.
AM3 machine owners, use Wheel No.6.

FINISHING: Pick up lower edges and work 8 rows Garter Stitch either by hand or put back onto machine and reverse every row. Do the same on sleeve edges but gather in a bit. Sew side and sleeve seams. Sew on Yoke and embroider as shown in Picture. Finish Buttonholes and work 1 or 2 rows single crochet along fronts and neckline then 1 row reverse single crochet.

BEGIN ALL SECTIONS WITH CONTRAST WASTE YARN. AFTER KNITTING 8 to 10 rows, CHANGE TO GARMENT YARN AND PUT COUNTER AT 0.

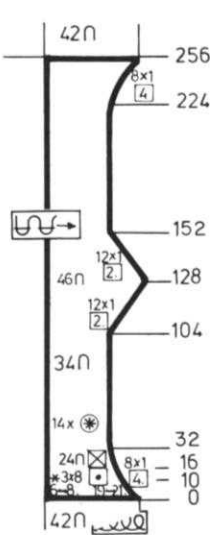
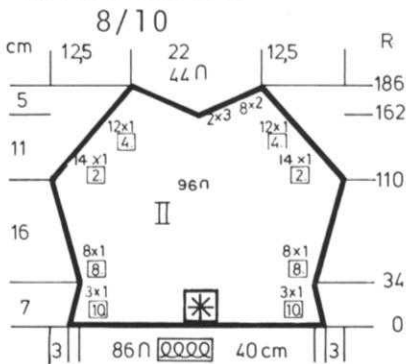

YOKE:

Cast on 42 sts. and work Stockinette stitch.
ON THE RIGHT, decrease 1 st. every 4th row 8x, BUT AT THE SAME TIME, make BUTTONHOLES after Row 4 over needles 6 to 8 and 19 to 21 counting from the left and WORK SHORT ROWS after Row 10.
*ON OPPOSITE SIDE OF CAM BOX, put into holding position 8 sts. 3x. Bring all the needles back into working position. Knit 10 rows**
REPEAT FROM * to ** 14x MORE BUT AT THE SAME TIME, after Row 104, increase 1 st. every 2nd row 12x.
After Row 128, decrease 1 st. every 2nd row 12x.
After Row 224, increase 1 st. every 4th row 8x.
After Row 256, bind off.



BACK: II

Cast on 86 (92) sts. and work in Pattern.
ON EACH SIDE, decrease 1 st. every 10th row 3x.
After Row 34, ON EACH SIDE, increase 1 st. every 8th row 8x.
After Row 110 (120) SHAPE RAGLAN: ON EACH SIDE, decrease 1 st. every 2nd row 14x, every 4th row 12x, and watch for NECK SHAPING. (every 4th row 10x, every 2nd row 16x), and watch for NECK SHAPING.
AT THE SAME TIME, after Row 162 (172) SHAPE NECK: Put half the sts. on the left into holding position and complete the right side first.
*ON NECK SIDE, bind off 3 sts. 2x, 2 sts. 8x. (3 sts. 1x, 2 sts. 11x).
Bring the needles on the left into working position, knit 1 row in Pattern to the left side, turn the Row Counter back to 162 (172) and complete the left half. Follow the instructions from * and don't forget to complete the raglan shaping.

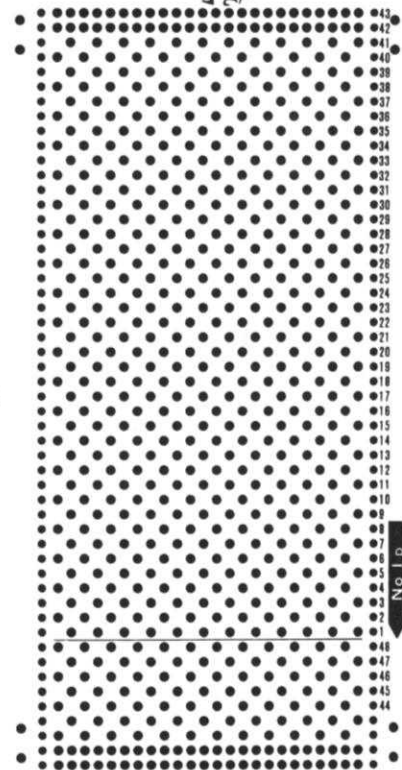

Continued

dk 575

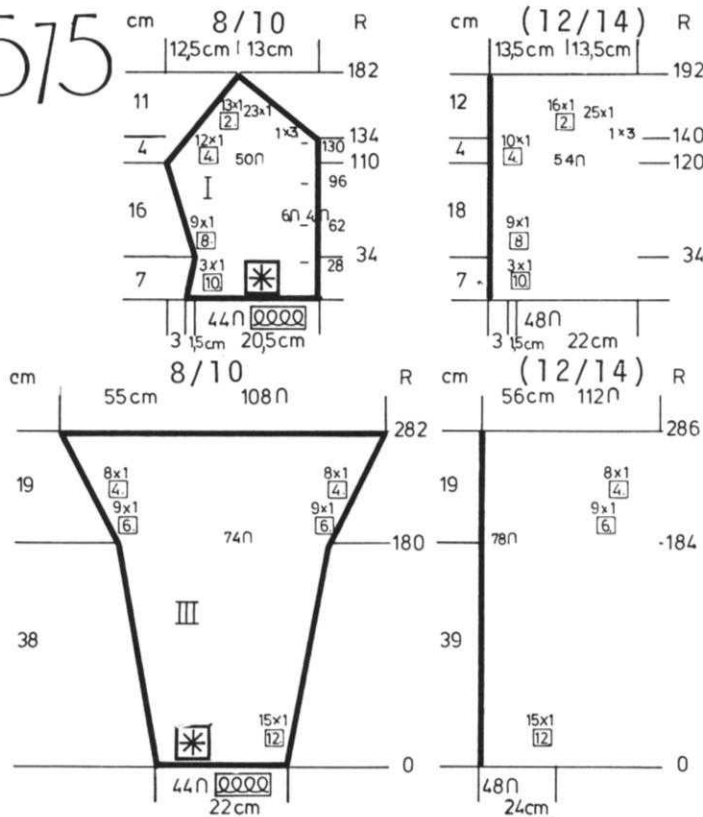

FRONT: I Make 1 reverse 1 and omit Buttonholes in 2nd section.

Cast on 44 (48) sts. and work in Pattern.
ON SIDE EDGE, decrease 1 st. every 10th row 3x, and AT THE SAME TIME, MAKE BUTTONHOLES over needles 4 to 6 counting from the right edge after the rows shown on the Chart. After Row 34, ON SIDE EDGE, increase 1 st. every 8th row 9x. After Row 110 (120) SHAPE RAGLAN: Decrease 1 st. every 4th row 12x, every 2nd row 13x, (watch for NECK SHAPING). (every 4th row 10x, every 2nd row 16x), (Watch for NECK SHAPING). AT THE SAME TIME ON NECK SIDE after Row 134 (140), Bind off 3 sts. 1x, then decrease 1 st. every 2nd row 23x (25x).

SLEEVES: III

Cast on 44 (48) sts. and work in Pattern.
ON EACH SIDE, increase 1 st. every 12th row 15x.
After Row 180 (184) SHAPE RAGLAN: ON EACH SIDE, increase 1 st. every 6th row 9x, every 4th row 8x.
After Row 282 (286), bind off.

np 576

MAN'S PULLOVER

SIZES: 38 (40) [42]
YARN: Allegro
GRAMS:
color 1 400 450 500
color 2 50 100 100
color 3 100 150 150
TENSION: 6 to 8
GAUGE: 14 sts. 19 rows = 5 cm (2")

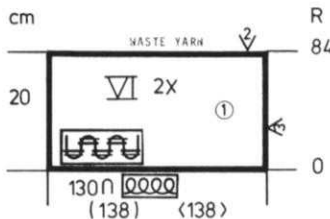

COLLAR: VI Make 2

Cast on 130 (138) [138] sts. with color 1 and work K2, P2 or K1, P1 Ribbing to Row 84 then remove the sts. onto contrast waste yarn.

BACK: II

Cast on 142 (152) [160] sts. with color 1 and work 32 rows K2, P2 or K1, P1 Ribbing.
Continue in Stockinette stitch with color stripes as shown on the Chart. Knit to Row 188 and mark each side with waste yarn for setting in the sleeves.
Knit to Row 260 (270) [270]. SHAPE SHOULDER and NECK AT THE SAME TIME.
Put half the sts. on the left into holding position and complete the right side first.
*FOR SHOULDER, bind off 7 sts. 4x, 8 sts. 2x. (8 sts. 5x, 9 sts. 1x). [8 sts. 2x, 9 sts. 4x].
FOR NECK, Bind off 15 (16) [16] sts. 1x, 6 sts. 2x.

Bring the needles on the left into working position, knit 1 row to the left side, turn the Row Counter back to 260 (270) [270] and complete the left half. Follow the instructions from *.

FRONT: I

Work the front the same as the back to Row 188. Bind off the center 54 sts. put the needles on the left into holding position and complete the right side first.
*Knit to Row 260 (270) [270] then SHAPE SHOULDER same as the back. Bring the needles on the left into working position, knit 1 row to the left side, turn the Row Counter back to 188 and complete the left half. Follow the instructions from *.

FINISHING: See General Instructions.

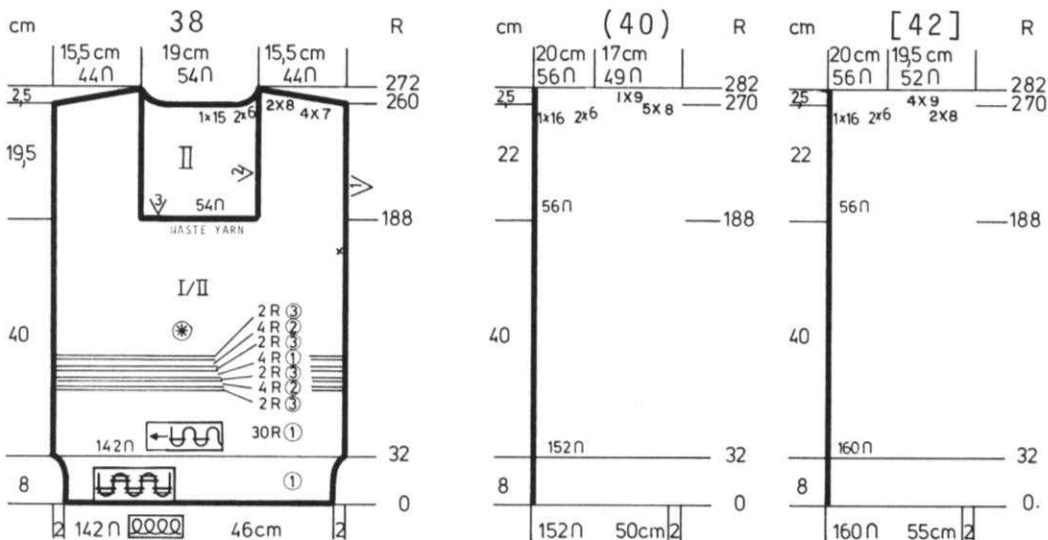

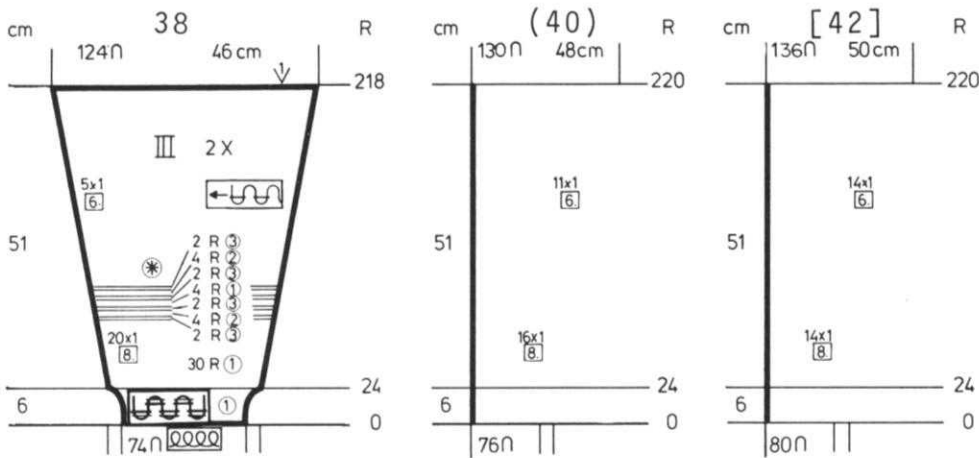

SLEEVES: III

Cast on 74 (76) [80] sts. with color 1 and work 24 rows K2, P2 or K1, P1 Ribbing. Continue in Stockinette stitch with color stripes as shown on the Chart. ON EACH SIDE, increase 1 st. every 8th row 20x (16x) [14x], then every 6th row 5x (11x) [14x]. After Row 218 (220) [220], bind off.

dk 577

WOMAN'S PULLOVER

SIZES: 8/10 (12/14)

YARN: Allegro

GRAMS:

color 1 350 400
color 2 100 100
color 3 100 100

TENSION: 6 to 8

GAUGE: 14 sts. 19 rows = 5 cm (2")

Stockinette stitch with REPEATED color stripes as shown on the Chart. Worn on the Purl side. Bands are K2, P2 or K1, P1 Ribbing.

FINISHING: See General Instructions. Sew Pocket Bands to front side edges. Fold Pocket on back to the inside and sew in place.

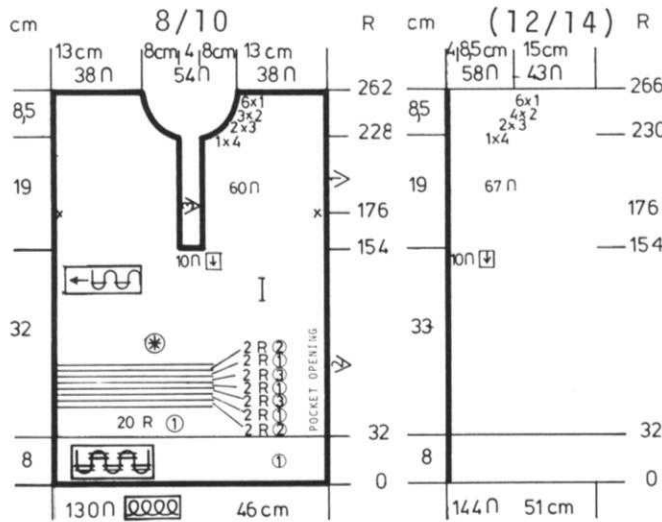

FRONT: I

Cast on 130 (144) sts. with color 1 and work 32 rows Ribbing. Continue in Stockinette stitch with REPEATED color stripes as shown on the Chart. Knit to Row 154. Remove the center 10 sts. onto a stitch holder, put the needles on the left into holding position and complete the right side first. *Knit to Row 227 (229). **SHAPE NECK:** Bind off 4 sts. 1x, 3 sts. 2x, 2 sts. 3x, 1 st. 6x. (4 sts. 1x, 3 sts. 2x, 2 sts. 4x, 1 st. 6x). After Row 262 (266), bind off the remaining sts. Bring the needles on the left into working position, knit 1 row to the left side, turn the Row Counter back to 154 and complete the left half. Follow the instructions from *.

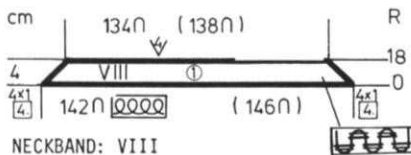

NECKBAND: VIII

Cast on 142 (146) sts. with color 1 and work Ribbing. ON EACH SIDE, decrease 1 st. every 4th row 4x. After Row 18, bind off the crochet method for Ribbing.

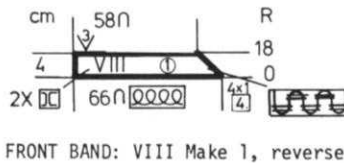

FRONT BAND: VIII Make 1, reverse 1.

Cast on 66 sts. with color 1 and work Ribbing. ON THE RIGHT (left for 2nd section) decrease 1 st. every 4th row 4x. After Row 18, bind off the crochet method for Ribbing.

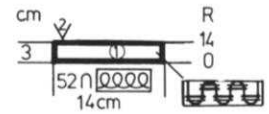

POCKET BAND: Make 2.

Cast on 52 sts. color 1 and work Ribbing. After Row 14, bind off the crochet method for Ribbing.

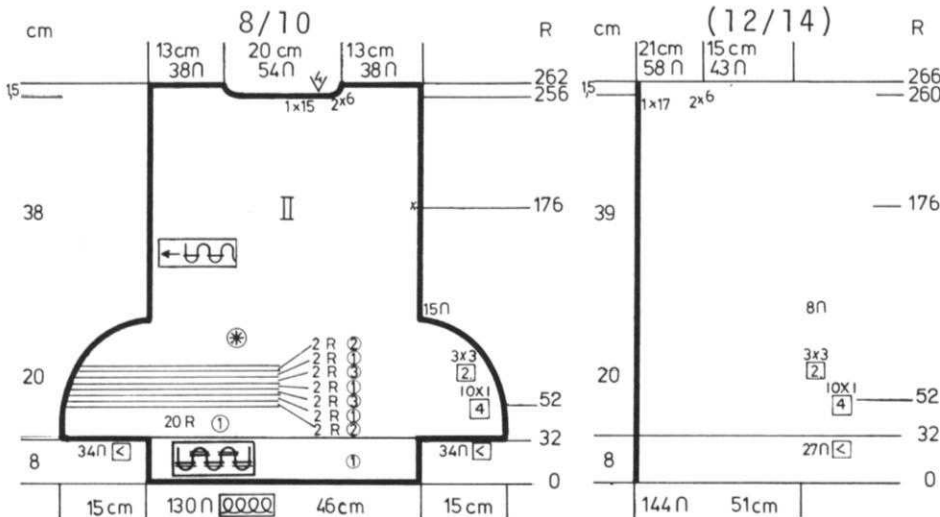

BACK: II

Cast on 130 (144) sts. with color 1 and work 32 Rows Ribbing. Continue in Stockinette stitch. Cast on 34 sts. ON EACH SIDE, then work the REPEATED color stripes as shown on the Chart. After Row 52 ON EACH SIDE, bind off 1 st. every 4th row 10x, every 2nd row 3 sts. 3x, then 15 sts. 1x. Knit to Row 176. Mark each side for setting in sleeves. Knit to Row 256 (260). **SHAPE NECK:** Put half the sts. on the left into holding position and complete the right side first. *ON NECK SIDE, bind off 15 (17) sts. 1x, 6 sts. 2x. After Row 262 (266) bind off the remaining sts. Bring the needles on the left into working position, knit 1 row to the left side, turn the Row Counter back to 256 (260) and complete the left half. Follow the instructions from *.



Continued

dk 577

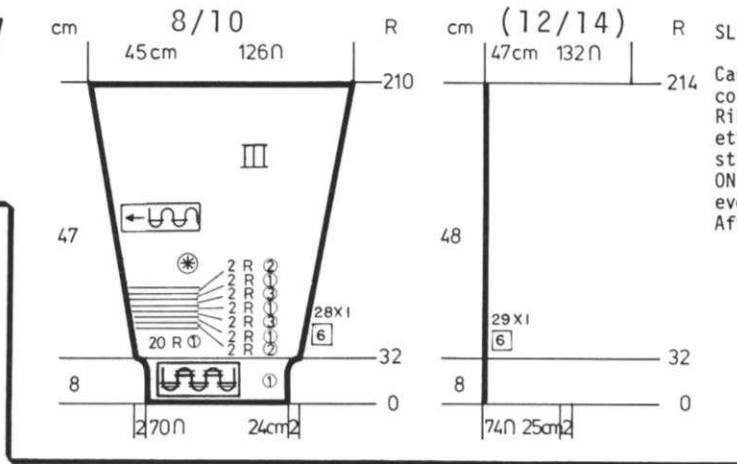

SLEEVES: III

Cast on 70 (74) sts. with color 1 and work 32 rows Ribbing. Continue in Stockinette stitch with REPEATED color stripes as shown on the Chart. ON EACH SIDE, increase 1 st. every 6th row 28x (29x). After Row 210 (214), bind off.

BACK: II

Cast on 128 (136) sts. and work 32 rows K1, P1 Ribbing. Continue in FISHERMAN'S RIB. Knit to Row 262. SHAPE ARMHOLE: ON EACH SIDE, bind off 2 sts. 3x, 1 st. 2x. (3 sts. 1x, 2 sts. 2x, 1 st. 4x). Knit to Row 398. SHAPE SHOULDER and watch for NECK SHAPING. FOR SHOULDER, ON EACH SIDE, bind off 3 sts. 9x, 4 sts. 1x. (3 sts. 9x, 5 sts. 1x). FOR NECK: After Row 402, put half the sts. on the left into holding position (or you may remove them onto waste yarn) and complete the right side first. (You must transfer the ribber sts. to main machine before you can put them into holding position).

*ON NECK SIDE, bind off 18 sts. 1x, 3 sts. 1x, 2 sts. 2x. for both sizes. Transfer the proper rib sts. to the ribber for the left side (WATCH PATTERN) Knit 1 row to the left, turn the Row Counter back to 402 and complete the left half. Follow the instructions from * and don't forget to complete the shoulder shaping.



dk 578

WOMAN'S TENNIS ENSEMBLE

SIZES: 8/10 (12/14)
YARN: Vienna

GRAMS:
color 1 1000 1100
color 2 150 150

TENSION:
Ribbing: 5 to 7
Stock: 6 to 8

GAUGE:
Rib: 14 sts. 34 rows = 5 cm (2")
Stock: 14 sts. 20 rows = 5 cm (2")
16" Jacket type Zipper.

Skirt is Stockinette stitch knitted sideways on the machine. Jacket is FISHERMAN'S RIB with bands in K1, P1 Ribbing.

FINISHING: See General Instructions.

SKIRT: Weave the open sts. held on waste yarn then remove waste yarn. Hem lower edge. Make hem at waist and insert elastic through casing. SOCKS: Weave the open sts. of heel to open sts. of leg. Sew up back seam. JACKET: Work 1 row single crochet around pocket openings then sew band to front edge and make pocket lining and sew in place on the inside.

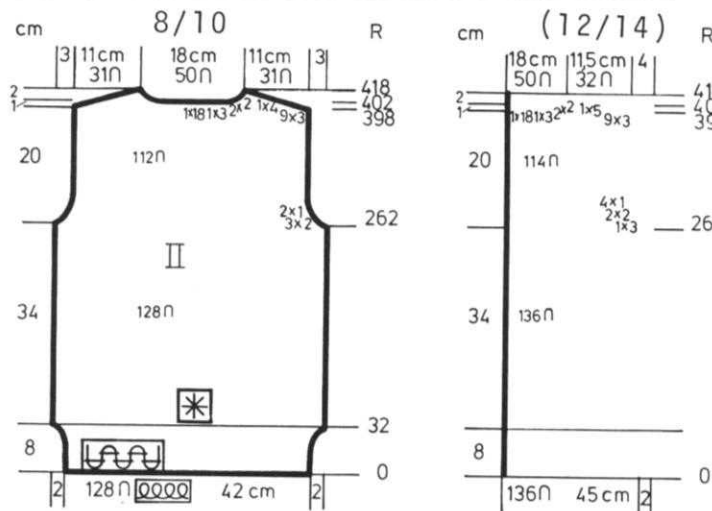

POCKET BAND:

Cast on 44 sts. with color 1 and work 14 rows K1, P1 Ribbing then bind off the crochet method for Ribbing.

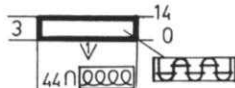

FRONT: I Make 1, reverse 1.

Cast on 64 (70) sts. and work 32 rows K1, P1 Ribbing. Continue in FISHERMAN'S RIB. Knit to Row 60.

ON THE LEFT (right for 2nd section) remove 25 (28) sts. onto contrast waste yarn and knit to Row 136. Remove these sts. onto waste yarn. Hang the 25 (28) sts. held on waste yarn back onto the machine, transferring the proper rib sts. to the Ribber (WATCH PATTERN). Put Counter at 60 and work in Pattern to Row 136.

Hang the 39 (42) sts. back onto the machine transferring the proper rib sts. to the Ribber and set counter at 136. Continue in Pattern over all the sts. to Row 250. Bind off 10 sts. for neck.

After Row 261, SHAPE ARMHOLE: Bind off (AND WATCH FOR NECK SHAPING) 3 sts. 1x, 2 sts. 2x, 1 st. 2x, (3 sts. 2x, 2 sts. 2x, 1 st. 2x).

AT THE SAME TIME, ON NECK side, bind off 2 sts. every 20th row 7x. (2 sts. every 20th row 8x).

After Row 397, SHAPE SHOULDER same as the back.



NECKBAND:

Cast on 192 sts. with color 1 and work K1, P1 Ribbing with color stripes as shown on the Chart. After Row 20, bind off the crochet method for Ribbing.

SOCKS:

Cast on 72 sts. and work K1, P1 Ribbing with color stripes as shown on the Chart. After Row 84, remove 18 sts. ON EACH SIDE onto contrast waste yarn. Continue in Stockinette stitch with color 1. Knit to Row 144.

Work SHORT ROWS: ON OPPOSITE SIDE OF CAM BOX, put into holding position, 1 st. 6x ON EACH SIDE. ON OPPOSITE SIDE OF CAM BOX, bring back into working position 1 st. till all are in work. Knit to Row 228. REPEAT THE SHORT ROWS from * to * and after Row 252, remove the sts. onto contrast waste yarn.

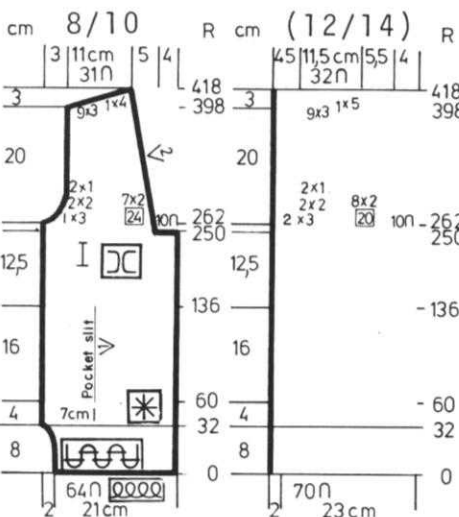

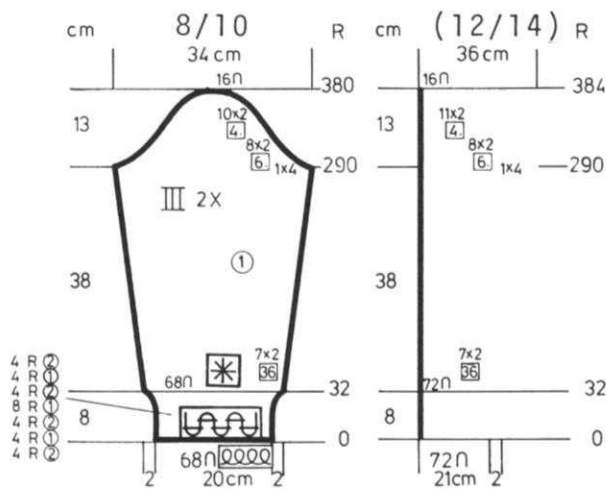

SLEEVES: III

Cast on 68 (72) sts. with color 2 and work K1, P1 Ribbing with color stripes as shown on the Chart. After Row 32, continue in FISHERMAN'S RIB.

ON EACH SIDE, increase 2 sts. every 36th row 7x.

After Row 290, SHAPE CAP: ON EACH SIDE, bind off 4 sts. 1x, then every 6th row 2 sts. 8x, and every 4th row 2 sts. 10x (11x).

After Row 380 (384) bind off the remaining sts.

SKIRT: Knitted sideways on the machine.

With contrast waste yarn, cast on 140 (152) sts. Knit 8 to 10 rows then continue with garment yarn and work Stockinette stitch with SHORT ROWS using color 1.

*Counter at 0. Knit to Row 14 (16). WORK SHORT ROWS: ON OPPOSITE SIDE OF CAM BOX, put into holding position 20 sts. 1x, 8 (9) sts. 13x. Bring back into working position 8 (9) sts. 13x, 20 sts. 1x. Knit to Row 82 (86).** Put Counter at 0 and REPEAT from * to ** 8x more. Remove the sts. onto contrast waste yarn.

DK 580

WOMAN'S BLOUSE & SKIRT
(goes with DK 581)

SIZES: 10 (12) [14]
YARN: Vienna
GRAMS: Skirt - color 1 500 550 600
 Blouse - color 2 200 250 300
 color 1 50 100 100
TENSION: 6 to 8
GAUGE: 16 sts. 21 rows = 5 cm (2")

Skirt is Stockinette stitch made in 6 sections.
 Blouse is Stockinette stitch with Norwegian Border using same Pattern Card as DK 581. Ribbed Bands.

FINISHING: See General Instructions.

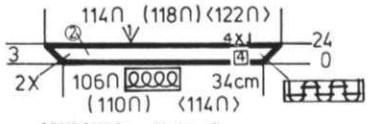
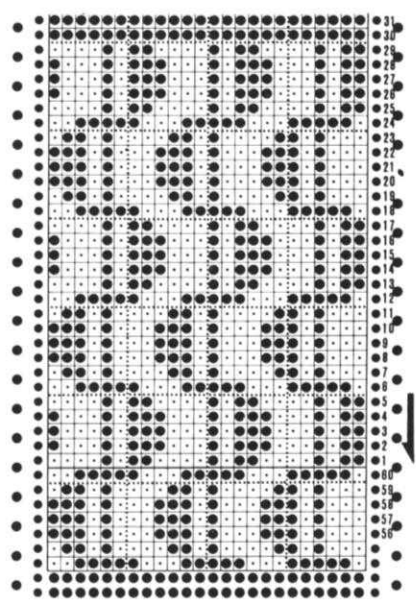
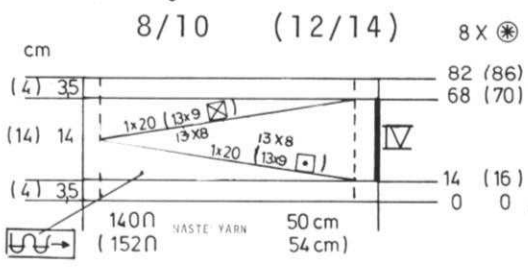

ARMBANDS: Make 2. Cast on 106 (110) [114] sts. with color 2 and work K1, P1 Ribbing. ON EACH SIDE, increase 1 st. every 4th row 4x. After Row 24, bind off the crochet method for Ribbing.

FRONT: I

Cast on 140 (152) [168] sts. with color 2 and work 32 rows K1, P1 Ribbing. Continue with the Norwegian Design to Row 57. Continue in Stockinette stitch with color 2. After Row 118 (122) [132] ON EACH SIDE, increase 1 st. every 2nd row 4x, then ON EACH SIDE, cast on 17 (13) [13] sts. After Row 126 (130) [140], ON EACH SIDE, increase 1 st. every 10th row 7x, BUT AT THE SAME TIME, After Row 150 (156) [162], SHAPE NECK: Put half the sts. on the left into holding position and complete the right side first. *ON NECK SIDE, bind off 9 sts. 1x, 5 sts. 2x, 4 sts. 2x, 3 sts. 3x for all sizes and AFTER Row 196 (202) [210] SHAPE SHOULDER: Bind off 7 sts. 8x, 6 sts. 1x. (8 sts. 8x) [8 sts. 8x]. Move the Cam Box to the left side, turn the Row Counter back to 150 (156) [162] and complete the left half. Follow the instructions from *.

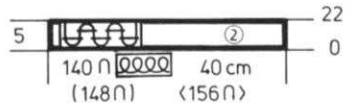

NECKBAND:
 Cast on 140 (148) [156] sts. with color 2 and work 22 Rows K1, P1 Ribbing then bind off the crochet method for Ribbing.

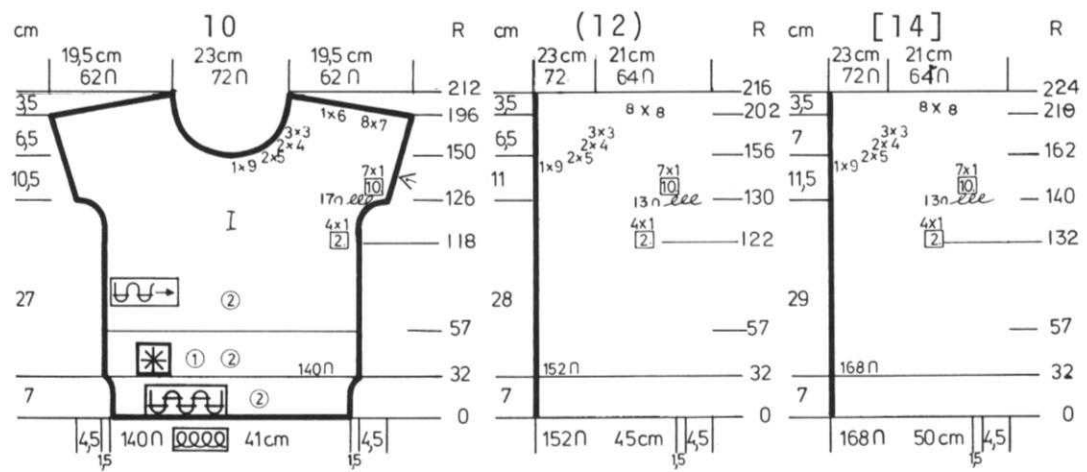

dk 580

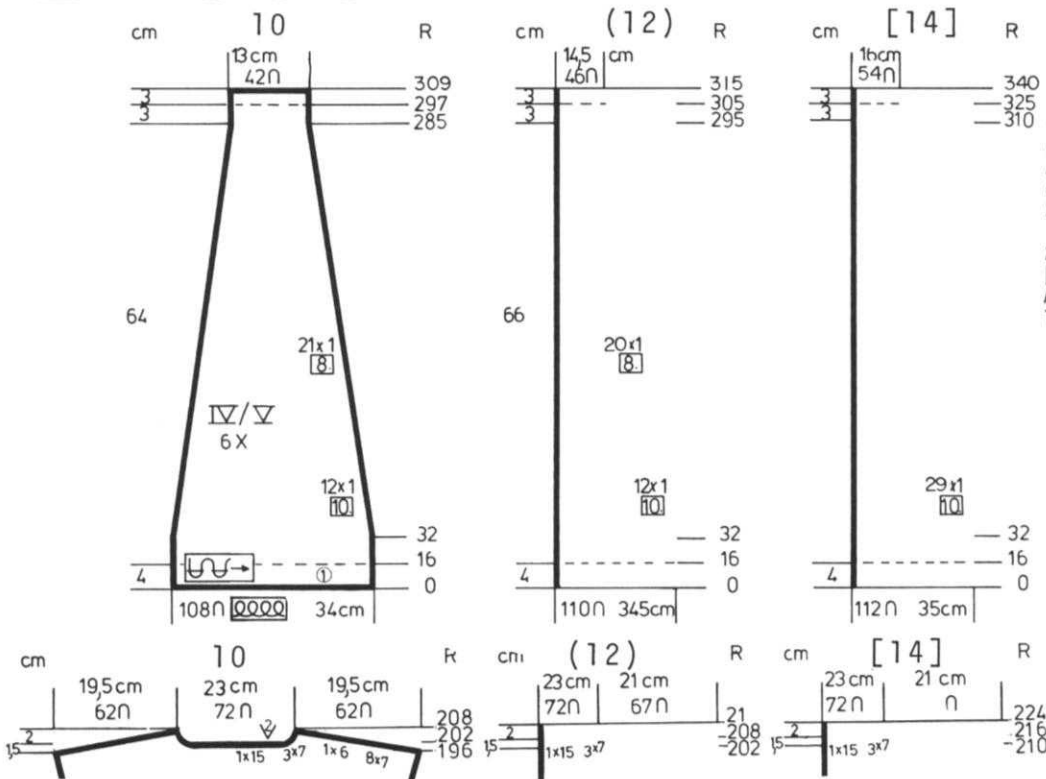

Cast on 108 (110) [112] sts. with color 1 and work Stockinette stitch. After Row 32, decrease 1 st. every 10th row 12x, every 8th row 21x. (every 10th row 12x, every 8th row 20x). [every 10th row 29x]. After Row 309 (320) [340], bind off loosely.

BACK: I
 Work the back the same as the front to Row 196 (202) [210]. SHAPE SHOULDER same as the front but after Row 202 (208) [216]. SHAPE NECK; Put half the sts. on the left into holding position and complete the right side first. *ON NECK SIDE, bind off 15 sts. 1x, 7 sts. 3x for all sizes. Move the Cam Box to the left side, turn the Row Counter back to 202 (208) [216] and complete the left half. Follow the instructions from * but don't forget to complete the shoulder shaping.

dk 581

WOMAN'S JACKET

SIZES: 10 (12) [14]
 YARN: Vienna
 GRAMS: color 1 300 350 350
 color 2 200 200 200
 TENSION: 6 to 8
 GAUGE: Stock: 16 sts. 21 rows = 5 cm (2")
 Pat: 16 sts. 18 rows = 5 cm (2")



A Norwegian Design and Stockinette stitch. Punch your own Card or follow the Line Drawing. Bands are K1, P1 Ribbing.

FINISHING: See General Instructions.

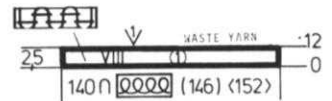
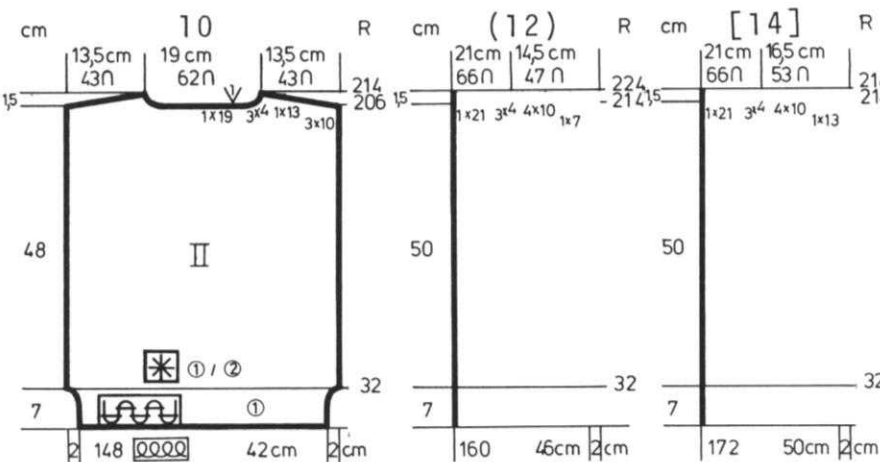

NECKBAND: VIII

FRONT BAND: Make 2.

Cast on 174 (184) [190] sts. with color 1 and work 16 rows K1, P1 Ribbing. Bind off the crochet method for Ribbing.

Cast on 140 (146) [152] sts. with color 1 and work 12 rows K1, P1 Ribbing. Transfer the ribber sts. to main machine then remove onto contrast waste yarn.

BACK: II

Cast on 148 (160) [172] sts. with color 1 and work 32 rows K1, P1 Ribbing.

Continue in Pattern. Knit to Row 206 (214) [214]. SHAPE SHOULDER AND NECK AT THE SAME TIME.

Put half the sts. on the left into holding position and complete the right side first.

*FOR SHOULDER, bind off 10 sts. 3x, 13 sts. 1x, (7 sts. 1x, 10 sts. 4x), [13 sts. 1x, 10 sts. 4x], FOR NECK, bind off 19 (21) [21] sts. 1x, 4 sts. 3x.

Bring the needles on the left into working position, knit 1 row in Pattern to the left side, turn the Row Counter back to 206 (214) [214] and complete the left half. Follow the instructions from *.



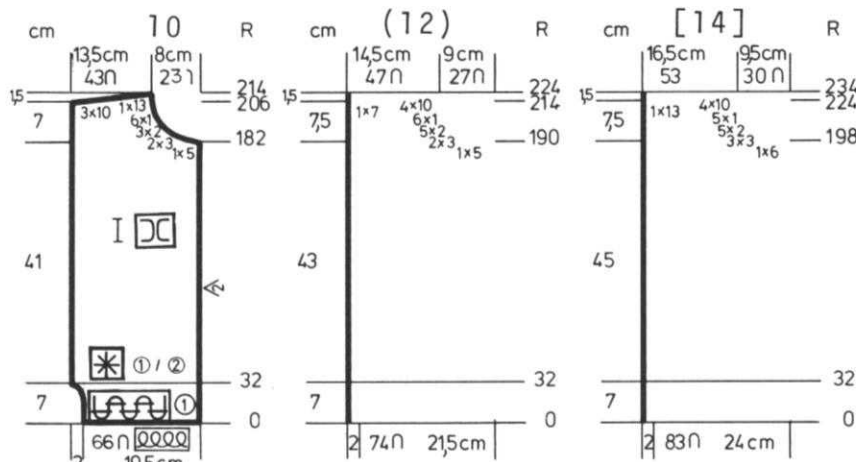

FRONT: I Make 1, reverse 1.

Cast on 66 (74) [83] sts. with color 1 and work 32 rows K1, P1 Ribbing. Continue in Pattern. Knit to Row 182 (190) [198].
 SHAPE NECK: Bind off 5 sts. 1x, 3 sts. 2x, 2 sts. 3x, 1 st. 6x. (5 sts. 1x, 3 sts. 2x, 2 sts. 5x, 1 st. 6x) [6 sts. 1x, 3 sts. 3x, 2 sts. 5x, 1 st. 5x].
 After Row 205 (213) [223], SHAPE SHOULDER same as the back.

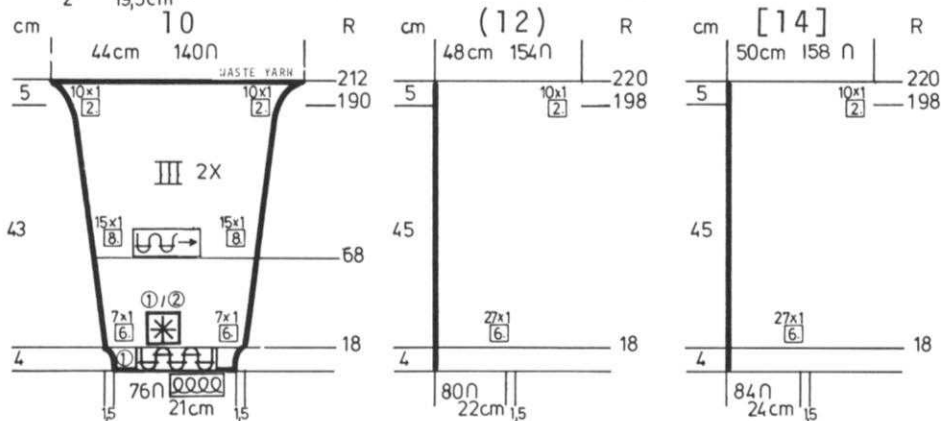

SLEEVES: III

Cast on 76 (80) [84] sts. with color 1 and work 18 Rows K1, P1 Ribbing. Continue in Pattern. ON EACH SIDE, increase 1 st. every 6th row 7x, every 8th row 15x,

(every 6th row 27x), [every 6th row 27x], AT THE SAME TIME, change to Stockinette stitch with color 1 after Row 68. After Row 190 (198) [198], ON EACH SIDE, increase 1 st. every 2nd row 10x. After Row 212 (220) [220], remove the sts. onto contrast waste yarn.

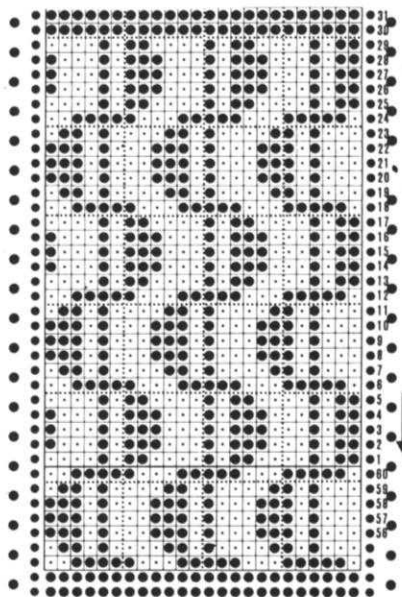

KK 579

CHILD'S HOODED ROBE

SIZES: Years 2/3 (4/5) [6/7]
 YARN: Allegro

GRAMS:
 color 1 300 350 400
 color 2 200 250 300

TENSION: 8 to 10
 GAUGE: 12 sts. 28 rows = 5 cm (2")

*A Tuck Stitch. 830 machine owners use Card No. 2D. AM 3 machine owners, use Wheel No. 6.

FINISHING: See General Instructions. Sew Hood in place. Make crochet loop for closure and sew on Button (see picture). Make twisted cord for Belt.

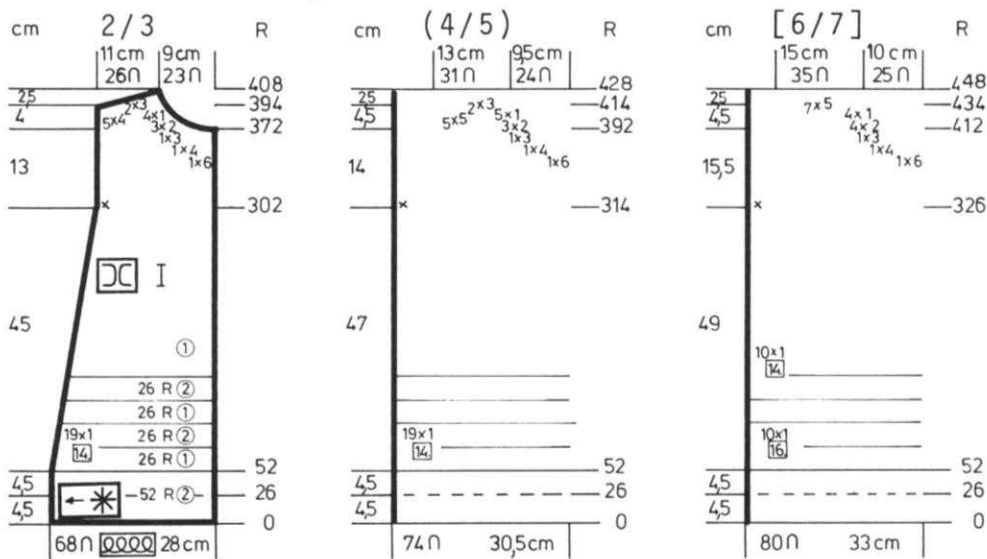

FRONT: I Make 1, reverse 1.

Cast on 68 (74) [80] sts. with color 2 and work in Pattern with color stripes as shown on the Chart. After Row 52, ON SIDE EDGE, decrease 1 st. every 14th row 19x. (same as first size).

[every 16th row 10x, every 14th row 10x]. After Row 302 (314) [326], mark for sleeve as you did before. After Row 372 (392) [412], SHAPE NECK: Bind off 6 sts. 1x, 4 sts. 1x, 3 sts. 1x, 2 sts. 3x, 1 st. 4x. (6 sts. 1x, 4 sts. 1x, 3 sts. 1x,

2 sts. 3x, 1 st. 5x). [6 sts. 1x, 4 sts. 1x, 3 sts. 1x, 2 sts. 4x, 1 st. 4x]. After Row 393 (413) [433], SHAPE SHOULDER same as the back.



KK 579

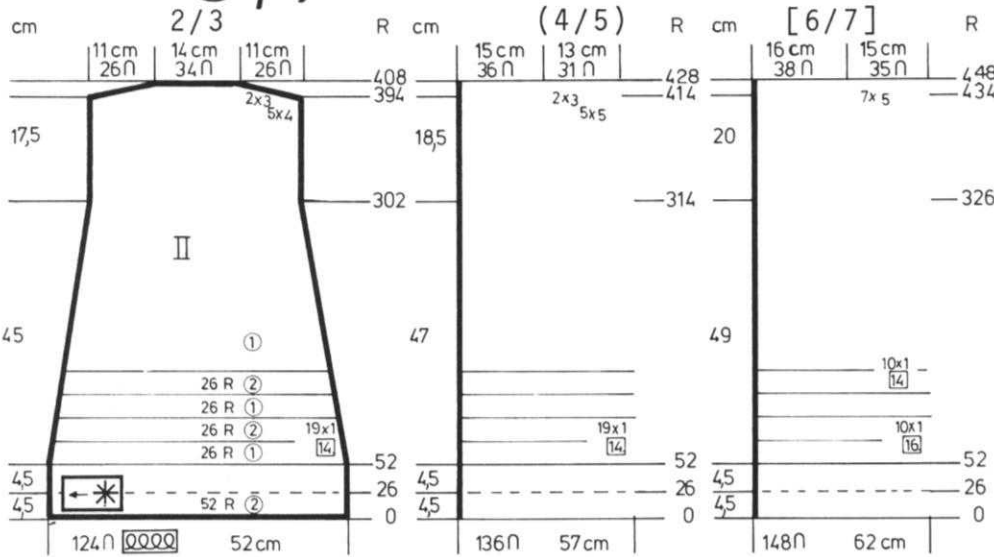

BACK: II
 Cast on 124 (136) [148] sts. with color 2 and work in Pattern with color stripes as shown on the Chart.
 Knit to Row 52.
 ON EACH SIDE, decrease 1 st. every 14th row 19x (same as first size) [every 16th row 10x, every 14th row 10x].
 After Row 302 (314) [326], mark each side for setting in sleeves.
 Knit to Row 394 (414) [434].
 SHAPE SHOULDER: ON EACH SIDE bind off
 4 sts. 5x, 3 sts. 2x.
 (5 sts. 5x, 3 sts. 2x).
 [5 sts. 7x].
 After Row 408 (428) [448], bind off the remaining sts.

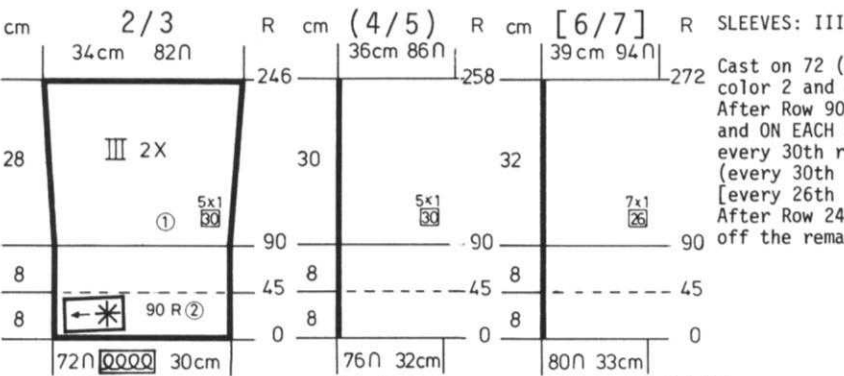
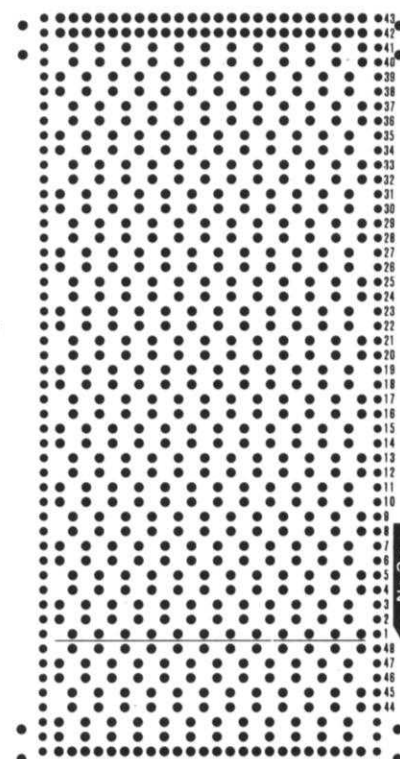

SLEEVES: III
 Cast on 72 (76) [80] sts. with color 2 and work in Pattern.
 After Row 90, change to color 1 and ON EACH SIDE, increase 1 st. every 30th row 5x. (every 30th row 5x) [every 26th row 7x].
 After Row 246 (258) [272], bind off the remaining sts.

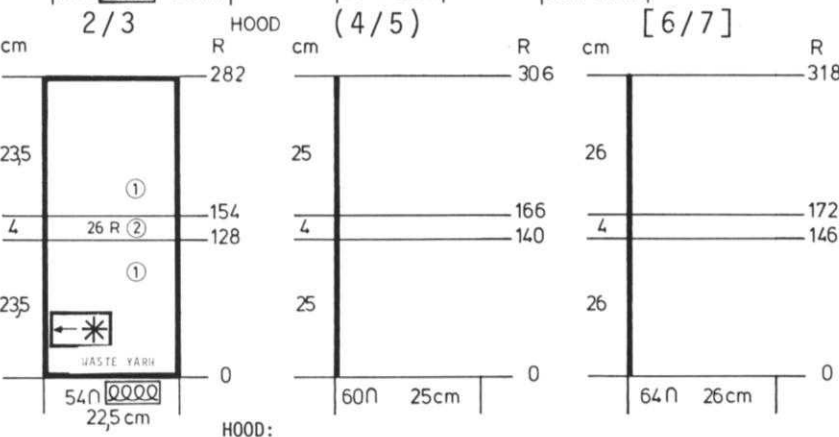

HOOD:
 With contrast waste yarn, cast on 54 (60) [64] sts. Knit 8 to 10 rows, change to color 1, put counter at 0 and work in Pattern. After Row 128 (140) [146], change to color 2.
 After Row 154 (166) [172], change to color 1.
 After Row 282 (306) [318], remove the sts. onto contrast waste yarn.

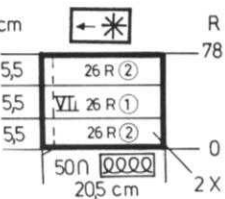

POCKETS: Make 2.

Cast on 50 sts. with color 2 and work in Pattern with color stripes as shown on the Chart. After Row 78, bind off.

KK 582



WOMAN'S PULLOVER & SCARF

SIZES: 10/12 (14/16)
 YARN: Allegro
 GRAMS:
 Pullover 500 550
 Scarf 400 400
 TENSION: 6 to 8
 GAUGE: 14 sts. 19 rows = 5 cm (2")

The Pullover is knitted in Stockinette stitch with sleeve bands and Collar in Ribbing. The scarf is Fisherman's Rib knitted over every other needle.

FINISHING: See General Instructions. Work 1 row single crochet along slits for pocket on side seams. Cut pocket lining from fabric 20 cm x 20 cm and round off 1 corner as shown on the Chart. Sew to slit and tack down on the inside.

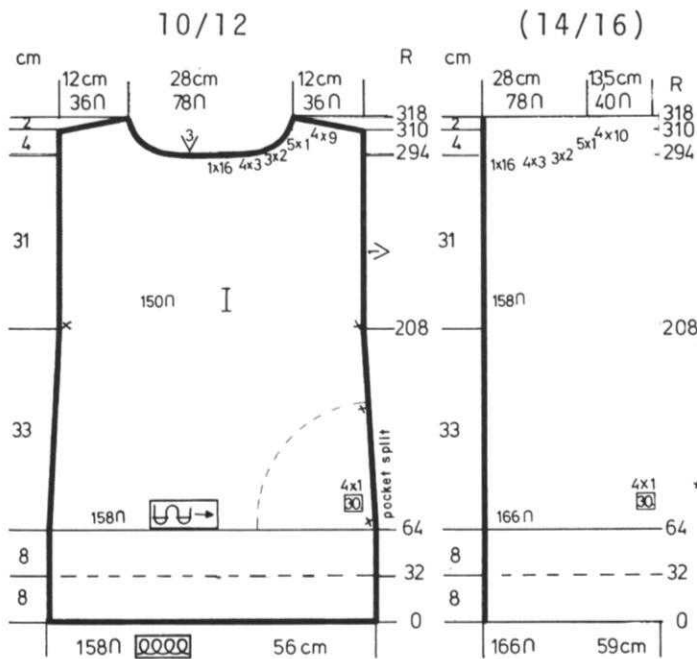

BACK: II

Cast on 158 (166) sts. and work Stockinette stitch. Knit to Row 64. Hang the hem if you wish. ON EACH SIDE, decrease 1 st. every 30th row 4x.
208 Knit to Row 208. Mark each side for setting in sleeves.
Knit to Row 310.
SHAPE SHOULDER AND NECK AT THE SAME TIME.
Put half the sts. on the left into holding position and complete the right side first.
*FOR SHOULDER, bind off 9 (10) sts. 4x.
FOR NECK, bind off 33 sts. 1x, 2 sts. 3x for both sizes.
Move the Cam Box to the left side bring the needles into working position and complete the left half. Follow the instructions from *.

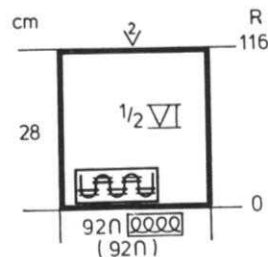

COLLAR BACK: VI Make 2.
Cast on 92 sts. and work 116 Rows K2, P2 or K1, P1 Ribbing. Bind off the crochet method for Ribbing.

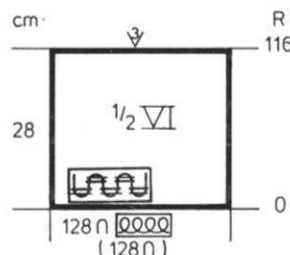

COLLAR FRONT: VI Make 2.

Cast on 128 sts. and work 116 rows K2, P2 or K1, P1 Ribbing. Bind off the crochet method for Ribbing.

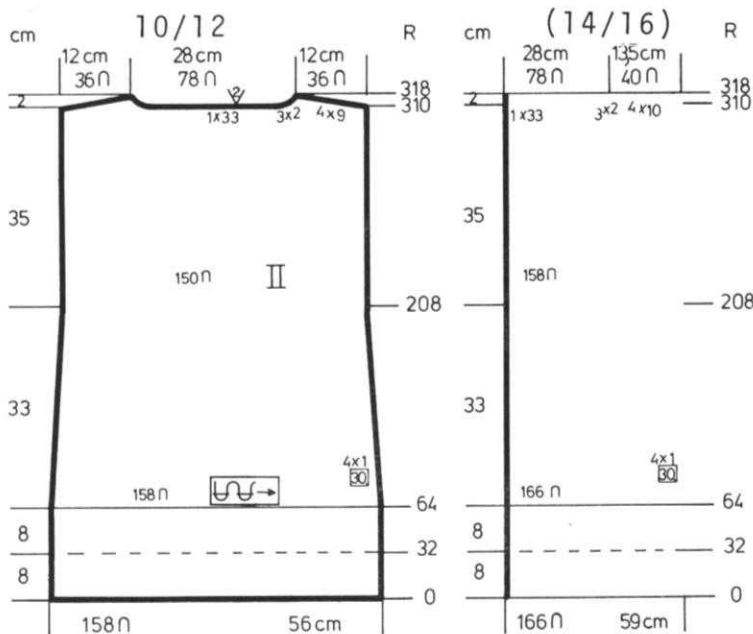

FRONT: I

Work the front the same as the back to Row 294.
SHAPE NECK: Put half the sts. on the left into holding position and complete the right side first.
*ON NECK SIDE, bind off 16 sts. 1x, 3 sts. 4x, 2 sts. 3x, 1 st. 5x for both sizes and SHAPE SHOULDER same as the back after Row 310.
Move the Cam Box to the left side, turn the Row Counter back to 294 and complete the left half. Follow the instructions from *.

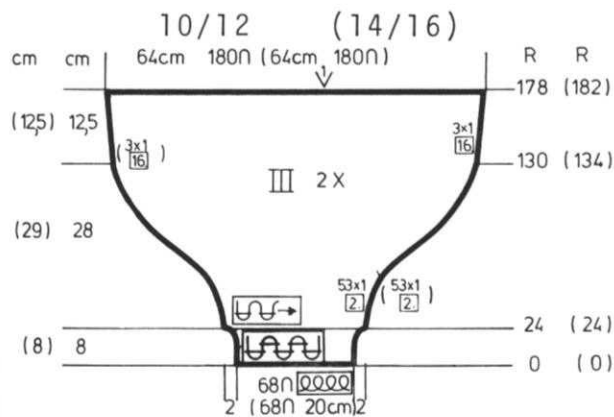

SLEEVES: III

Cast on 68 sts. and work 24 rows K1, P1 Ribbing. Continue in Stockinette stitch. ON EACH SIDE, increase 1 st. every 2nd row 53x.
After Row 130 (134) ON EACH SIDE, increase 1 st. every 16th row 3x.
After Row 178 (182, bind off.

SCARF: KNITTED OVER EVERY OTHER NEEDLE.

Cast on 34 sts. over EVERY OTHER NEEDLE and work Fisherman's Rib with Tension 10. Knit approximately 72". Pull both ends together and sew on Tassel. Above the Tassel sew on a ring of fur.



Knitking News

PRACTICAL KNITTING HINTS

EVERY OTHER NEEDLE PUNCH CARDS

When you have a Pattern for EVERY OTHER NEEDLE, it is very important for you to TRY THE PUNCH CARD before beginning a garment. Bring up EVERY OTHER NEEDLE - set your Punch Card. If the Pattern is incorrect - or you do not get a pattern, put the working needles OUT OF WORK and try the ALTERNATE NEEDLES.

TO MAKE A TWISTED CORD

Cut yarn at least 6 times the length you need for a cord. When it is folded in half and looped over a doorknob, it will be 3 times the length you need. You can use as many strands of yarn you wish for the thickness you want. Loop center of folded yarn around a doorknob and tie the other ends to the center of a pencil. Stand across the room, pulling the yarn strands taut. Twist the pencil round and round and as you twist, the yarn will also twist. Keep turning the pencil until the yarn begins to kink. Slide scissors handle down to center of cord and remove the yarn from the doorknob. Hold yarn end UP so that the two parts of cord will twist around each other. Tie each end and cut. If you are making a long cord, it is best for two people to work together - each twisting an end on a pencil. Bring the pencils together and one person hold them while the other grasps center of yarn and slides hand down, releasing at short intervals and allowing yarn to twist evenly to form the cord.

You can also use a small hand drill for twisting the cord. Simply insert the ends in place of a bit, tighten and turn the hand drill - quick too..

KNITKING FIGHTS INFLATION...

We are certain that most of our readers are aware of what is happening to the American Dollar in comparison with foreign currencies and how it is affecting the price of knitting machines and accessories... It seems just a few short years ago that there were 4 German Marks to the Dollar, currently there are approximately 2... This means that even if the price of German made products remained the same, (they of course have not) they would still cost us twice as much. Additionally custom duty is double, insurance and freight rates are more than double, the cost of living increases every year and as a consequence wages continue in an upward spiral, advertising costs seem to increase with every insertion...etc.

It does not seem very long ago that a first class letter was 3¢ for the first ounce... and in less than 5 years, the cost of mailing this magazine to you has tripled... A little over one year ago, it was possible to buy over 300 Japanese Yen for \$1.00. Now a dollar gets you around 240 Yen and it is still going down... Small wonder indeed that your knitting machines and accessories are costing you more and more... but... read on dear friends and discover that by doing business with KNITKING, you will save dollars with every purchase you make.

KNITKING FIGHTS INFLATION...

For several months now, much time has been taken up by KNITKING'S Board of Directors meetings analyzing operating costs, profit and loss statements, etc. etc... In order to determine how KNITKING can fight inflation as it applies to the Home Knitting Machine industry with special considerations for our substantial number of loyal, and regular customers. (U.S. readers will receive an additional 4 pages of advertising in this issue of KNITKING MAGAZINE that will reflect our determination to fight inflation... KNITKING MAGAZINE goes out to 14 different countries and as our prices are for the U.S. market only, it would be a waste of time and money to include these 4 extra pages in all copies that go abroad).

It is customary in the U.S. for knitting machine importers to appoint distributors around the country. The distributors in turn are supposed to stock machines and products for sale to their own appointed dealers who sell direct to the public and insure that personal and individual instruction is available for every knitting machine purchaser.

It is unlikely that any knitting machine importer has ever made the Distributor division of their business function satisfactorily and KNITKING has tried harder than most... We have therefore decided that we will no longer use Distributors as intermediaries, we will sell direct to the consumers through our competent dealers and we will make new dealer appointments wherever possible. By doing this we eliminate distributor profits which can be turned over to the consumer in the form of reduced prices... All KNITKING dealers are expected to have the ability and the facility to teach customers how to operate their knitting machines.

KNITKING already has a network of teachers (who do not sell machines) throughout the U.S. but we need more. If you would like to earn extra money just teaching knitting machine owners how to operate their machines, write to us... It could be the start of a whole new career for you.

For over 20 years, KNITKING has arranged financing (throughout the U.S.) for the purchase of knitting machines and every year we write off thousands of dollars of bad debts caused by skips, bankrupts, and people who just won't pay their bills. These bad debts increase our operating costs and as a consequence the price of merchandise to the consumer... We will continue to accept Visa and Mastercharge Cards but no more 12 or 24 month contracts. If a customer's credit is good, he or she will experience no problem in obtaining credit in the form of a loan from a local bank or finance company... Again, savings will be passed on to our customers in the form of reduced prices.

We cannot however prevent the continuation of inflation, so if you live in this wonderful U.S.A., check our Special Sale Brochure in this issue and order as much merchandise as you can afford NOW...

KITS FOR THIS ISSUE OF KNITKING MAGAZINE

Yarn Kits for the garments in this issue of KNITKING MAGAZINE are specially discounted for our subscribers so be sure to take advantage of them. Please remember that the special discounts are only good until the next issue of KNITKING MAGAZINE.

DISCOUNTS ON YARN KITS FOR THIS ISSUE

DK 560 - Yarn: Amore			
SIZES:	8/10		
Regular Price	\$23.84		
Sale Price	17.88		
Shipping Costs	1.65		
DK 561 - Yarn: Vienna & Amore			
SIZES:	8/10	(12/14)	[16]
Regular Price	\$39.96	\$44.73	\$46.52
Sale Price	29.98	33.55	34.89
Shipping Costs	2.15	2.15	2.15
DK 562 - Yarn: Allegro			
SIZES:	12 to 16		
Regular Price	\$12.72		
Sale Price	9.52		
Shipping Costs	1.65		
HP 563 - Yarn: Fortissima			
SIZES:	34/36	(38)	[40]
Regular Price	\$22.26	\$23.85	\$25.44
Sale Price	16.66	17.85	19.04
Shipping Costs	1.65	1.65	1.65
DK 564 - Yarn: Boucle			
SIZES:	10	(12)	
Regular Price	\$37.80	\$39.60	
Sale Price	28.35	29.70	
Shipping Costs	2.15	2.15	
DK 565 - Yarn: Allegro			
SIZES:	8/10	(12/14)	
Regular Price	\$17.49	\$19.08	
Sale Price	13.09	14.28	
Shipping Costs	1.65	1.65	
HP 566 - Yarn: Euro Sport			
SIZES:	38/40	(42/44)	
Regular Price	\$30.96	\$33.54	
Sale Price	23.28	25.21	
Shipping Costs	2.15	2.15	
KK 567 - Yarn: Fortissima			
SIZES:	8/10	(12)	[14]
Regular Price	\$12.72	\$14.31	\$15.90
Sale Price	9.52	10.71	11.90
Shipping Costs	1.65	1.65	1.65
DK 568 - Yarn: Knitting Worsted weight Yarn.			
HP 569 - Yarn: Euro Sport			
SIZES:	34/36	(38/40)	[42/44]
Regular Price	\$10.32	\$11.61	\$12.90
Sale Price	7.76	8.71	9.70
Shipping Costs	1.65	1.65	1.65
DK 570 - Yarn: Euro Sport			
SIZES:	7/8	(10/12)	[14]
Regular Price	\$10.32	\$11.61	\$12.90
Sale Price	7.76	8.71	9.70
Shipping Costs	1.65	1.65	1.65
DK 571 - Yarn: Allegro & Binia			
SIZES:	8/10	(12/14)	
Regular Price	\$30.60	\$32.19	
Sale Price	22.90	24.11	
Shipping Costs	1.65	2.15	
DK 572 - Yarn: Allegro			
SIZES:	8/10	(12/14)	
Regular Price	\$23.85	\$25.44	
Sale Price	17.85	19.04	
Shipping Costs	1.65	1.65	
DK 573 - Yarn: Beatrice Silver & Capriccio			
SIZES:	8/10	(12/14)	
Regular Price	\$24.77	\$27.46	
Sale Price	18.60	20.62	
Shipping Costs	1.65	1.65	
DK 574 - Yarn: Fortissima			
SIZES:	8/10	(12/14)	
Regular Price	\$ 7.95	\$ 9.54	
Sale Price	5.95	7.14	
Shipping Costs	1.65	1.65	
DK 575 - Yarn: Euro Sport			
SIZES:	8/10	(12/14)	
Regular Price	\$15.48	\$16.77	
Sale Price	11.64	12.61	
Shipping Costs	1.65	1.65	
HP 576 - Yarn: Allegro			
SIZES:	38	(40)	[42]
Regular Price	\$17.49	\$22.26	\$23.85
Sale Price	13.09	16.66	17.85
Shipping Costs	1.65	1.65	1.65
DK 577 - Yarn: Allegro			
SIZES:	8/10	(12/14)	
Regular Price	\$17.49	\$19.08	
Sale Price	13.09	14.28	
Shipping Costs	1.65	1.65	
DK 578 - Yarn: Vienna			
SIZES:	8/10	(12/14)	
Regular Price	\$41.17	\$44.75	
Sale Price	30.83	33.51	
Shipping Costs	2.15	2.15	
KK 579 - Yarn: Allegro			
SIZES:	2/3	(4/5)	[6/7]
Regular Price	\$15.90	\$19.08	\$22.26
Sale Price	11.90	14.28	16.66
Shipping Costs	1.65	1.65	1.65
DK 580 - Yarn: Vienna			
SIZES:	10	(12)	[14]
Regular Price	\$26.85	\$32.22	\$35.80
Sale Price	20.14	24.17	26.80
Shipping Costs	1.65	1.65	1.65
DK 581 - Yarn: Vienna			
SIZES:	10	(12)	[14]
Regular Price	\$17.90	\$19.69	\$19.69
Sale Price	13.40	14.74	14.74
Shipping Costs	1.65	1.65	1.65
DK 582 - Yarn: Allegro			
SIZES:	10/12	(14/16)	
Regular Price	\$28.62	\$30.21	
Sale Price	21.42	22.61	
Shipping Costs	1.65	1.65	

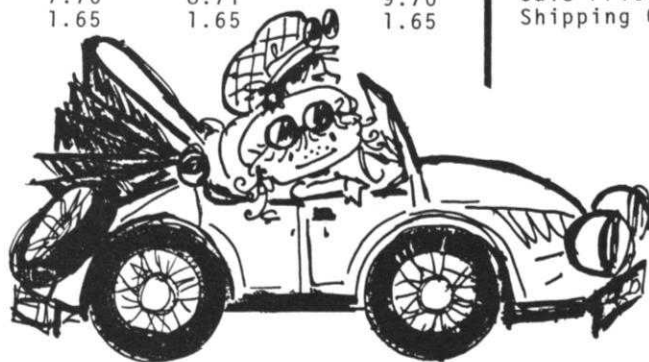

IT'S NEW!

FOR FAST, EASY AND ACCURATE GARMENT ASSEMBLY



from **KNITTING** the **bellinky** linking machine

- * THE BELLINKY SEAMS WITH GARMENT YARN, SHIRTING ELASTIC OR SEWING THREAD...
- * YOU CAN ACCURATELY MATCH JACQUARD, LACE DESIGNS OR STRIPES...
- * YOU CAN STRETCH OR EASE A SEAM AT WILL...
- * SLEEVES CAN BE SET IN AND NECKBANDS ATTACHED...
- * BLIND HEMS ARE TURNED EASILY...

ARE YOU TIRED OF JOINING SEAMS BY HAND...? DO YOUR SEAMS APPEAR UNEVEN NO MATTER HOW HARD YOU TRY...? DOES IT TAKE FOREVER TO FINISH YOUR KNIT...? WITH A BELLINKY YOUR PROBLEMS WILL DISAPPEAR AND ASSEMBLING GARMENTS WILL BE FUN....

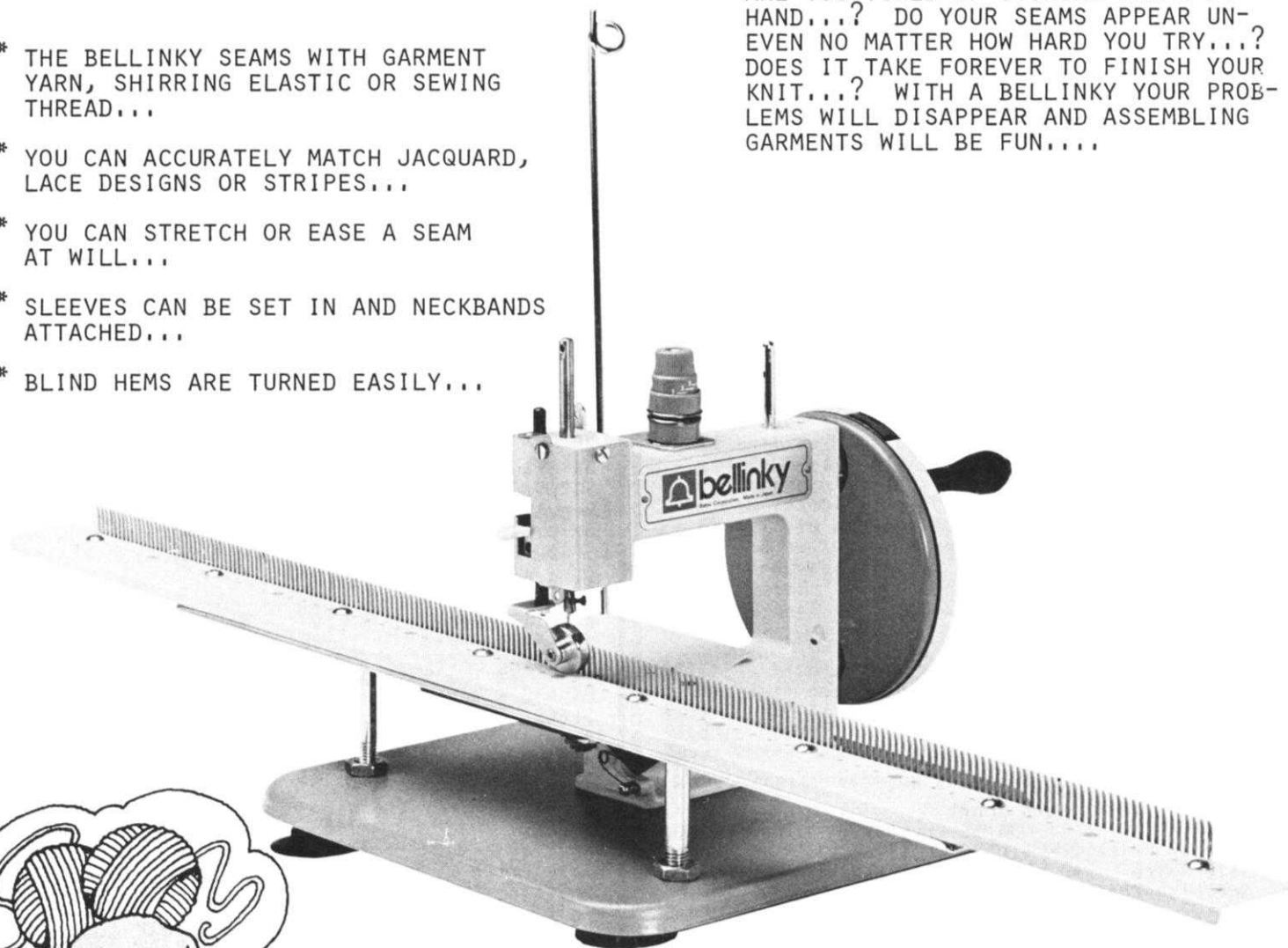

'If you KNIT you need me!'



dk 561



dk 565



dk 575

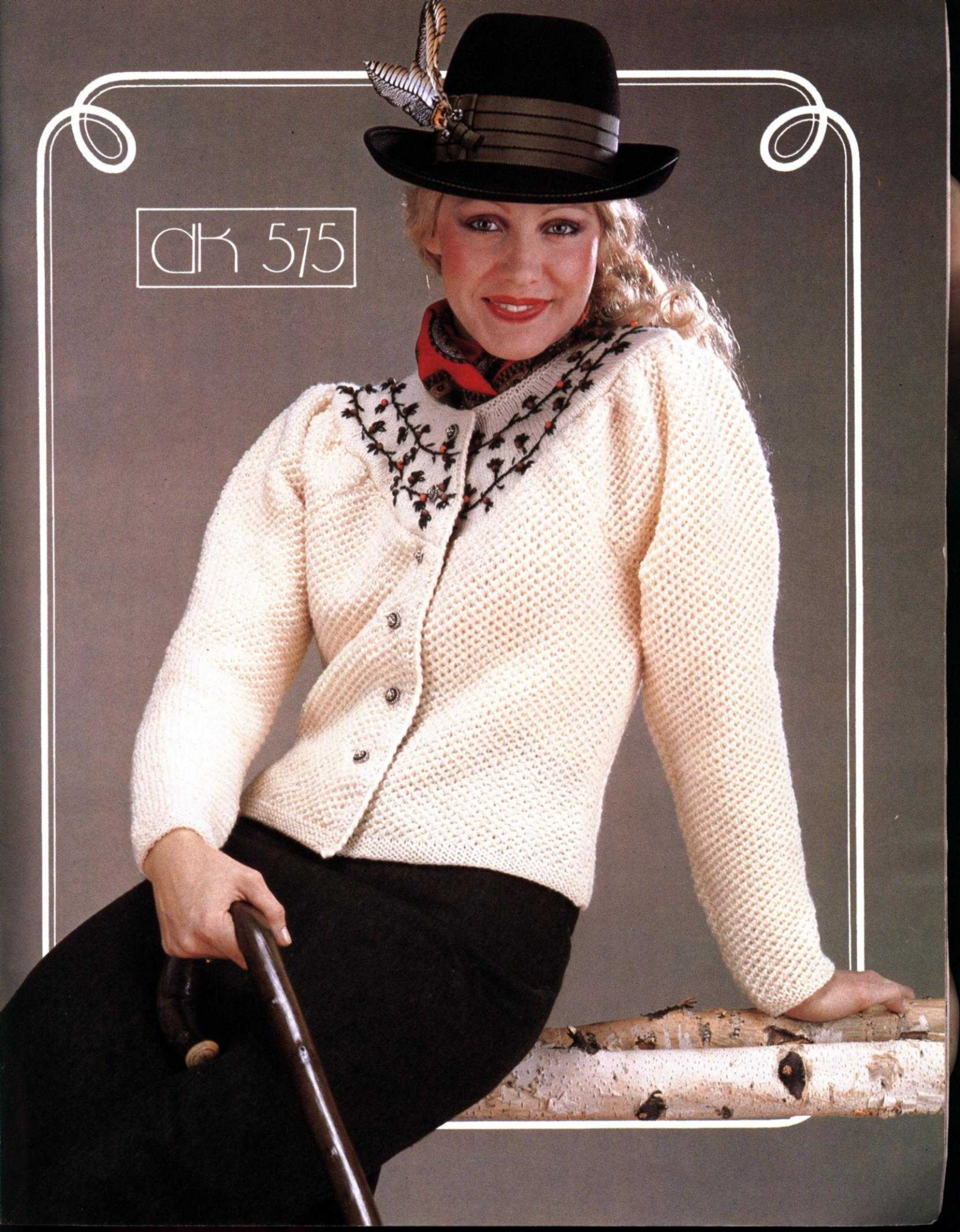



dk 568



dk 560

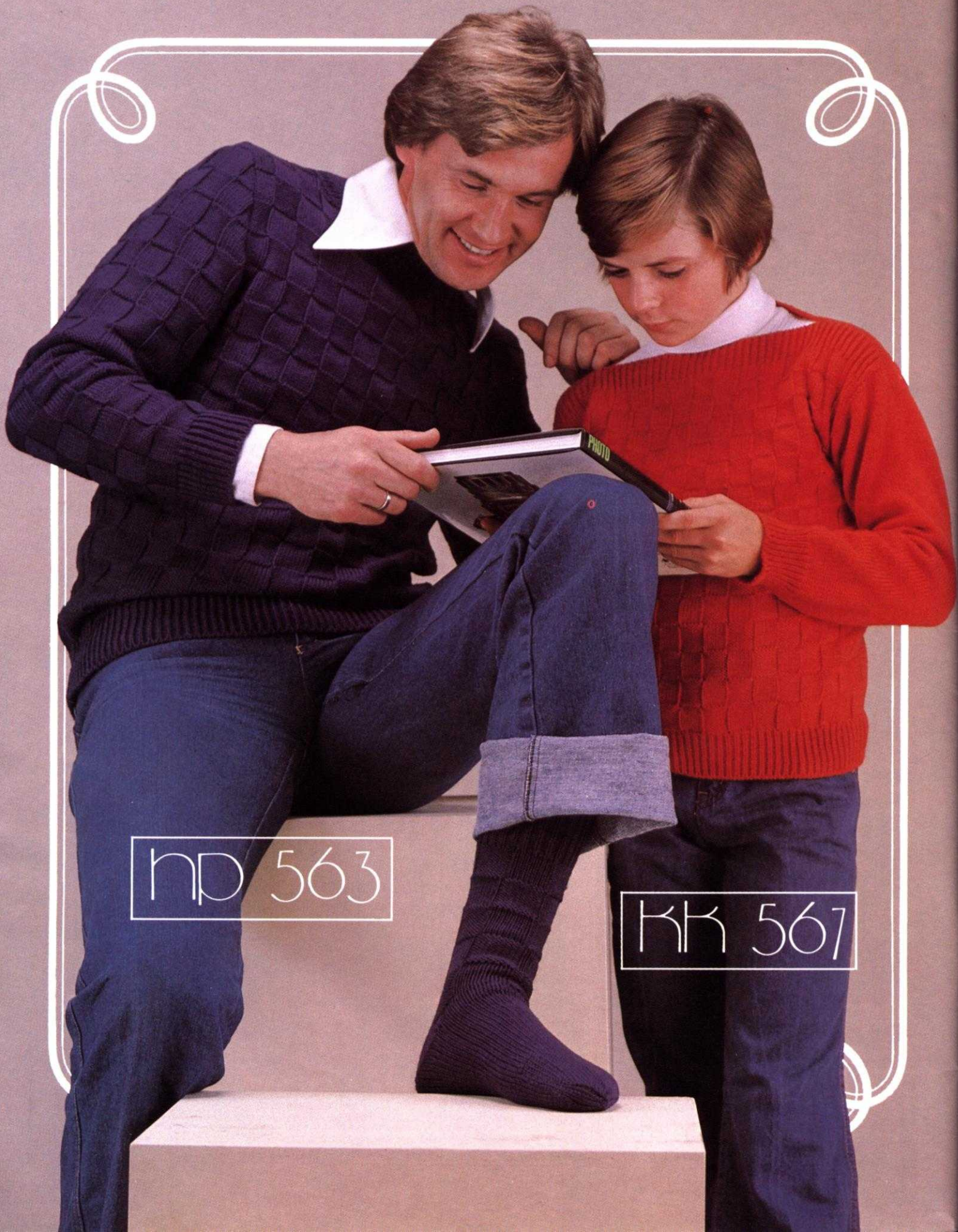

hp 563

KK 567

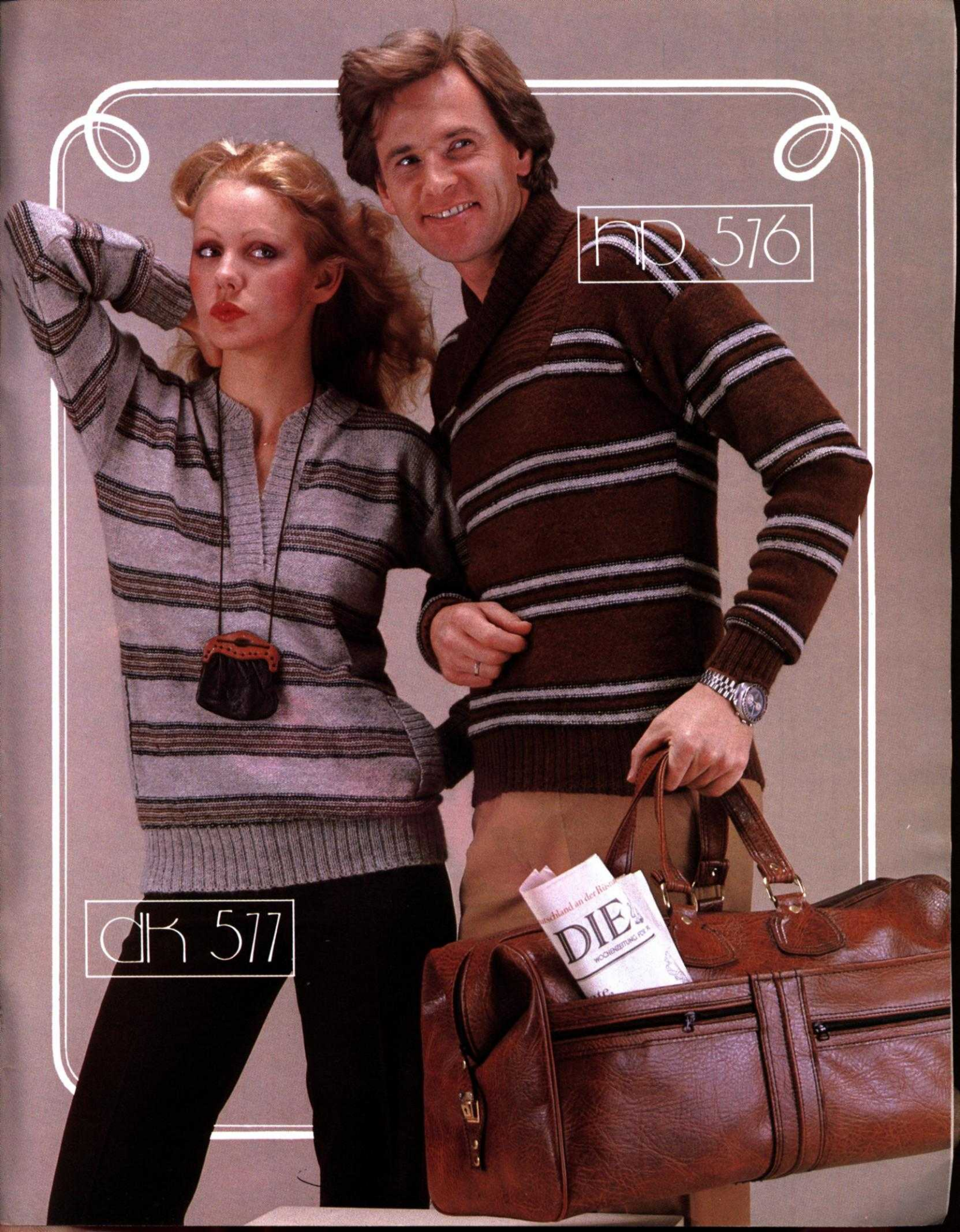

HP 576

OK 577

KK 579





dk 578



dk 581