

knitking

magazine

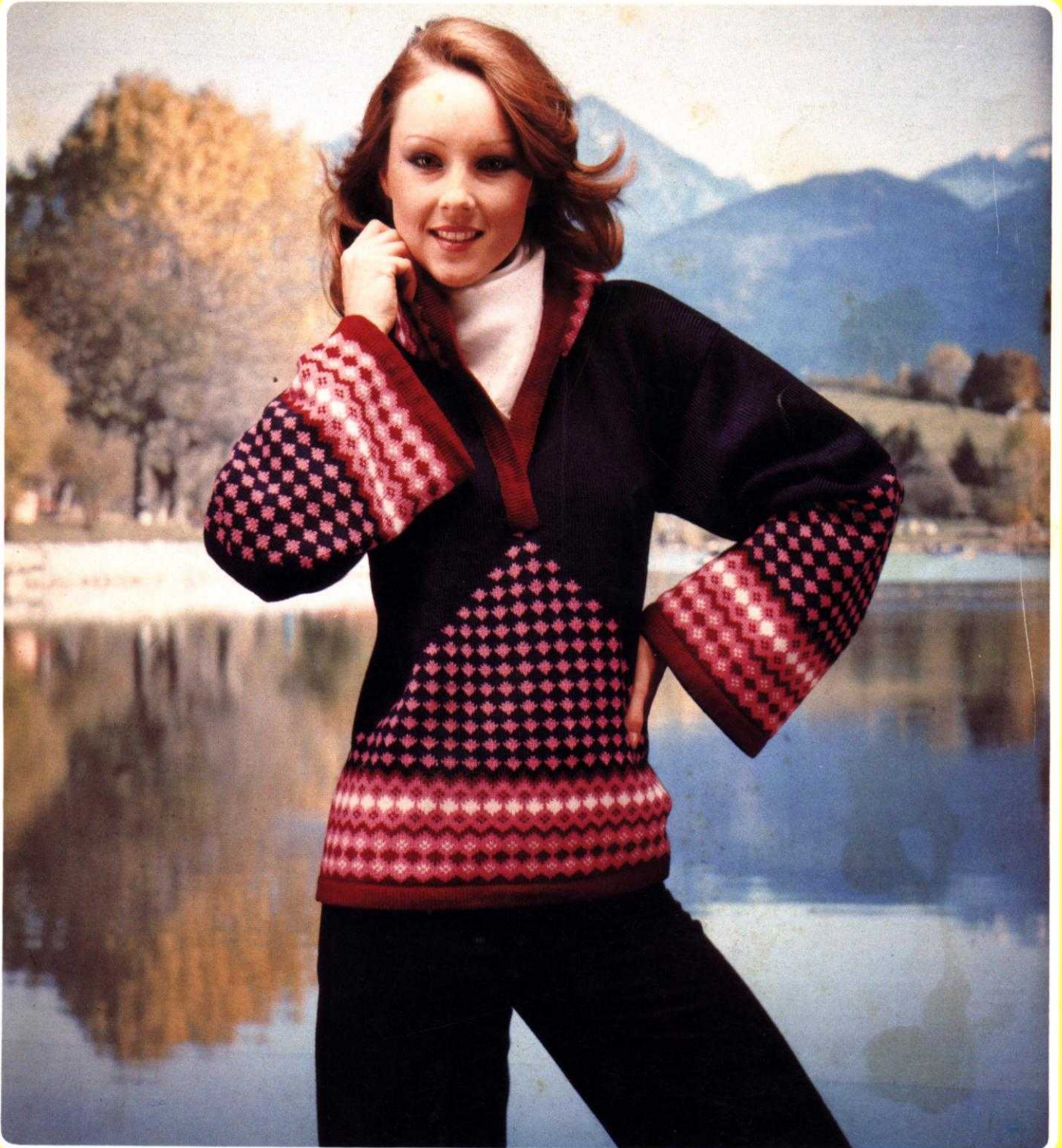

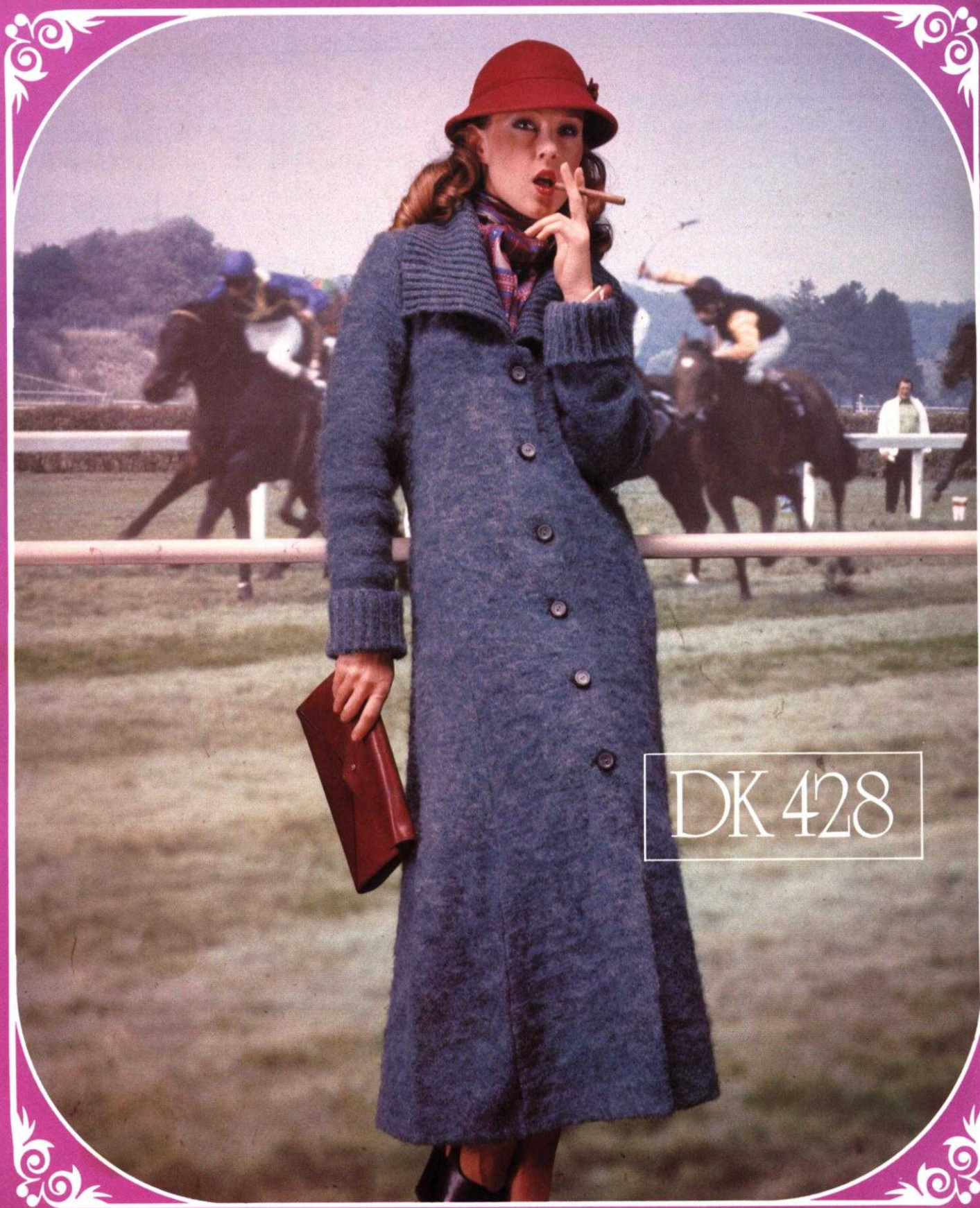

DK 428



DK 427



DK 446

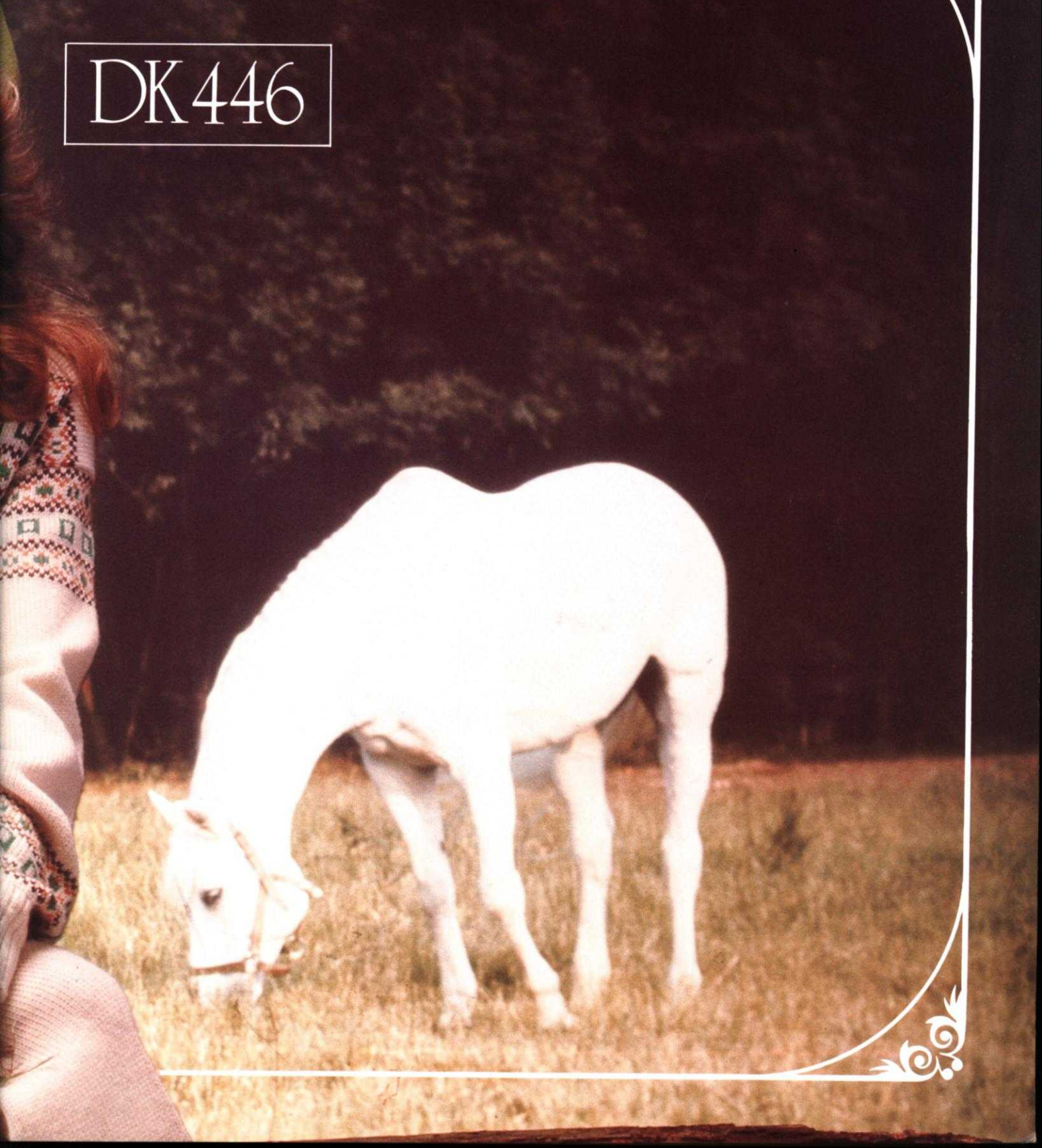

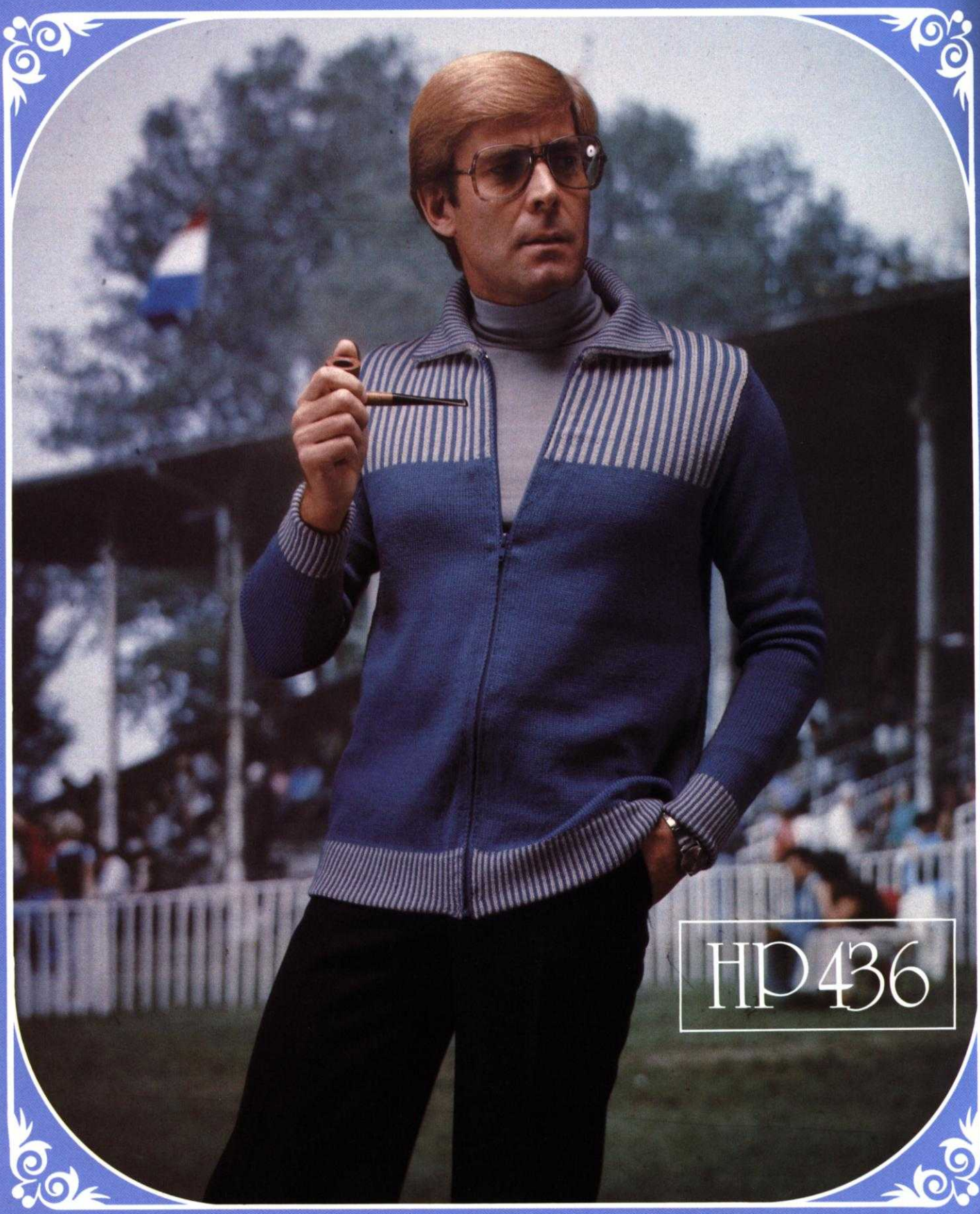

HP 436

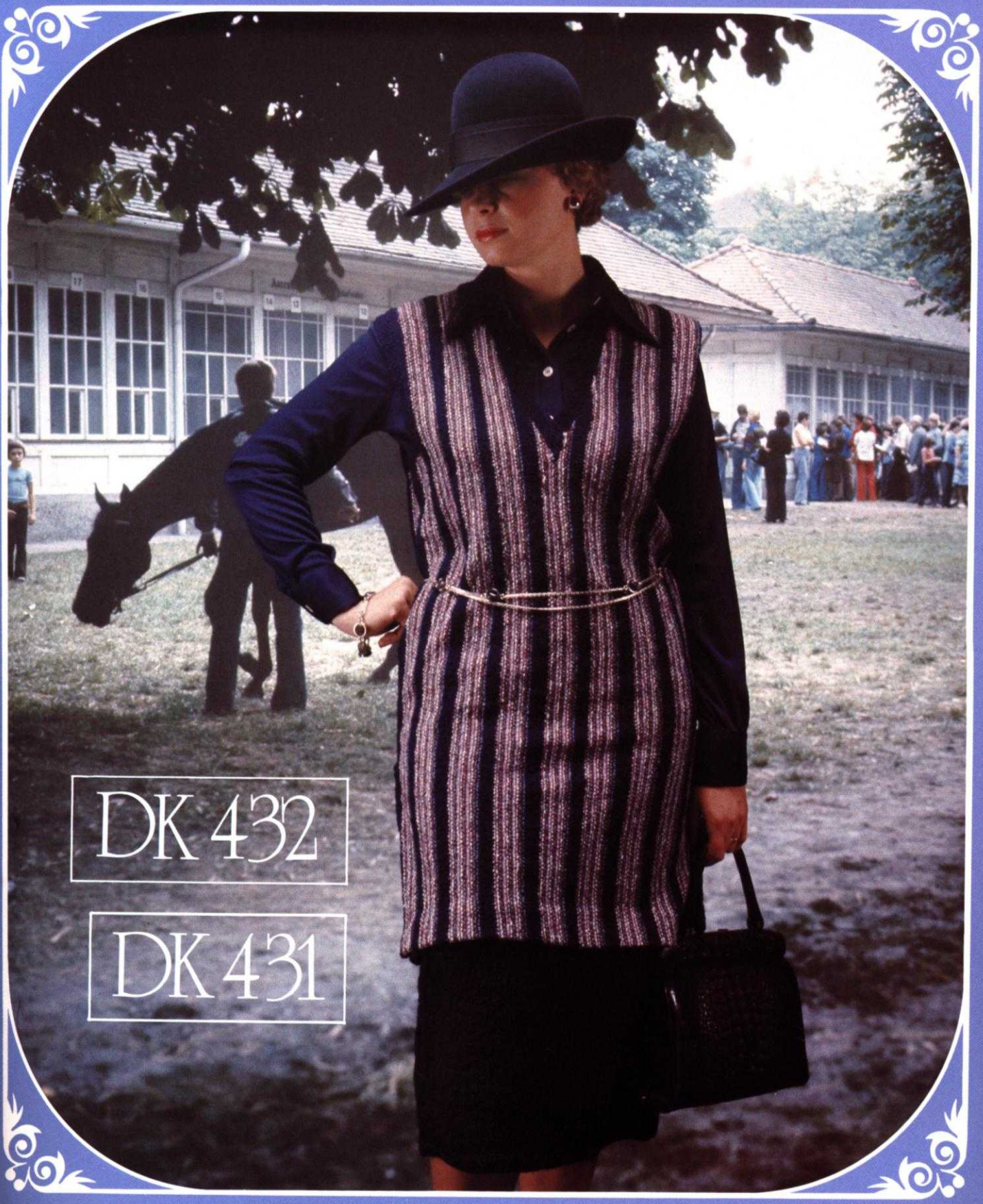

DK 432

DK 431



DK435

A woman with short, curly, light brown hair and glasses is smiling. She is wearing a light brown tweed jacket over a dark brown scarf and a matching brown skirt. She is holding a black handbag. She is standing on a white ledge at a racetrack, with a white fence and a grassy field in the background. A pair of black binoculars is on a small table to her left. The image is framed by a decorative border with floral motifs in the corners.

DK 429

DK 430

DK 437

DK 439



knitking

magazine

VOLUME 13, NO. 2

editorial

TABLE OF CONTENTS	PAGE NO.
KK 422 Girl's Skirt & Jacket	14
HP 423 Man's Pullover & Socks	15
KK 424 Girl's Poncho	16
KK 425 Boy's Jacket & Pants	18
KK 426 Girl's Skirt	19
DK 427 Woman's Coat	21
DK 428 Woman's Coat	22
DK 429 Woman's Jacket	23
DK 430 Woman's Skirt	24
DK 431 Woman's Skirt	25
DK 432 Woman's Tunic	25
DK 435 Woman's Jacket	26
DK 434 Woman's Dress & Shawl	27
HP 436 Man's Jacket	28
DK 437 Woman's Pullover	30
DK 438 Woman's Jacket	30
DK 439 Woman's Skirt with Fringe	32
DK 440 Woman's Jacket with Hood	32
HP 441 Man's Jacket	33
KK 442 Child's Overalls	35
KK 443 Girl's Jacket	35
KK 444 Child's Overalls	37
DK 445 Woman's Pullover with Hood	38
DK 446 Woman's Pants & Pullover	38
DK 447 Woman's Scarf & Cap	40
DK 448 Woman's 3/4 length Coat	41

In the more than twenty five years KNITKING has been in business, we have never been busier than we are at this time.. The new KNITKING WARDROBE PLAN has created more enthusiasm for machine knitting and greater interest on the part of established machine knitters... It seems that every knitter is asking about the WARDROBE PLAN and wants to know if it is possible to take advantage of the special services offered. We developed the program around the KNITKING KH 830 and KNITLEADER combination with full benefits in the form of free KNITLEADER CHARTS, special yarn and accessory discounts, free advisory service, etc., etc...going to purchasers of the new KNITKING KH 830... We have, however, received hundreds of letters from knitting machine owners wishing to join the Club, but who do not own a KNITKING KH 830 and who cannot afford to get one at this time.

We want all of our readers to take advantage of our services and to obtain full value from their knitting machine investments irrespective of the brands of machine owned, but obviously, we cannot give Charts and other services free to everybody and, in any case, our Charts are only suitable for machines that can use the KNITLEADER or similar full size Charts. We are, therefore, offering (starting with this issue of KNITKING MAGAZINE) KNITLEADER CHARTS to non-members for a small fee sufficient to cover our production costs. At present, they are only available with knitting kits... You will find more information in KNITKING NEWS on page 43.















KNITKING YARNS are also an integral part of the KNITKING WARDROBE PLAN... Only by knitting with top quality yarns can you produce top quality garments and there is no better range of yarn available than that in the latest KNITKING YARN CATALOGUE. Every subscriber to KNITKING MAGAZINE and every WARDROBE PLAN MEMBER is eligible for discount prices on kits for garments in each issue of the magazine, so be sure to check the price list on page 44 and order your KNITKING YARN KITS for some of the lovely garments in this issue.



We are preparing the next issue and it promises to be another outstanding one. There is something for every member of the family... Some things elegant, some things sporty, everything stylish... Purses are in, so we have some matching purses... Baby garments are demanded... so, we have them plus a Baby's Sleeping Bag that all parents and grandparents will just have to make.



Publisher: KNITKING CORPORATION, 1128 Crenshaw Blvd., Los Angeles, Calif. 90019. Telephone: (213) 938-2079. Published bi-monthly. Subscriptions: USA — \$10.00 annually, single copies \$3.00; Canada — \$12.00; other parts of the world — \$15.00. The entire contents of KNITKING MAGAZINE are copyright and must not be reproduced in any shape or form without the express permission, in writing of the publisher. © COPYRIGHT 1977 by KNITKING CORPORATION.

Pattern Symbols

Knitting – Chart Symbols

- () Size Symbols
(2nd Size)
- < > 3rd Size
- B** Beginners Pattern
- T** Tension
- G** Gauge
- ①** Color Number
-  Cast on
-  Stitch
- R** Row
- H** Hem
-  Bind off
-  Stockinette stitch – worn on the Knit side.
-  Stockinette stitch – worn on the Purl side.
-  Knit 1, Purl 1 Ribbing
-  Ribbing Pattern – worn on the Knit side.
-  Ribbing Pattern – worn on the Purl side.
-  Closed Dart
-  Open Dart
-  Put on a stitch holder
-  Reverse 1 section
-  On every other needle
-  Number of Rows between Shapings. Make increase (or decrease) FIRST, then knit 4 rows. For example: 3 x 1 **4** means decrease (or increase) 1 st., knit 4 rows; decrease 1 st., knit 4 rows; decrease 1 st., knit 4 rows; decrease 1 st., knit 4 rows. All decreasing (or increasing) without row numbers as shown must be shaped on every 2nd row.

-  Increase
-  Increase 2 sts. With a transfer tool, move the sts. over the left (or right) leaving 2 empty needles at the point of increase. At the increase point, move 1 st. to the left, (or right) so that there is an empty needles on each side of a stitch. On each side of the center stitch, pick up a stitch from the row below and hang it onto the empty needle.

-  3 stitches on 1 needle. The 1st and 3rd stitch in a group of 3 has been hung on the 2nd or center needle.
-  Short Row increase or decrease; for instance on a flared skirt knitted sideways.

-  Pattern Stitch
-  Pattern Stitch – worn on the Knit side.
-  Pattern Stitch – worn on the Purl side.





-  Norwegian Design using the Pattern Reader. Only 1 row must be registered on the Pattern Reader, so when knitting two or more colors in 1 row, knit the first color with the LEVER of Pattern Reader UP (working), then push the LEVER DOWN (non-working) for the additional colors.

REPEAT the above for each complete row.

-  Repeat

- I = Front
II = Back
III = Sleeve
IV = Skirt Front
V = Skirt Back
VI = Collar
VII = Pocket
VIII = Band
IX = Belt
X = Cuff
XI = Pants Front
XII = Pants Back

Finishing – Chart Symbols

-  Match numbers on section for assembling.
-  Ease
-  Fold Line
-  Turn to the wrong side and hem.

Stitch Symbols

-  Knit Stitch
-  Purl Stitch
-  Needles in holding position
-  Needles back into working position.
-  Empty needle (leave in working position)
-  Needle not used (in the out of work position).
-  Two stitches on 1 needle, either transferred from the right side or the left side, then put into holding position.
-  Needle holding 2 stitches. Stitch has been transferred from the RIGHT.
-  Needle holding 2 stitches. Stitch has been transferred from the LEFT.
-  Center of garment section
-  Pattern Reader
-  JAC 40
-  Adjustable Needle Selector
-  Pattern Wheel
-  Weaver
-  Needle Shifter

General Instructions

HOW TO READ THE CHARTS AND INSTRUCTIONS

There are 3 sizes given for each Pattern in KNITTING MAGAZINE. Above each Chart for the different sizes, you will see that the first and smaller sizes might be shown as 8/10, the second size as (12/14) and the third as [16/18]. Check the measurements at the bustline and hips on the Charts to be certain that you will knit the correct size, remembering these are ACTUAL measurements of the completed section and that there must be a bigger allowance at the bustline and hipline for a Jacket or a Coat than there would be for a fitted dress or a fitted blouse or pullover. The question in your mind should be "How do I want this garment to fit...?"

When you have chosen the size you need, you can follow the Charts as shown. You will notice that where the shapings are the same FOR ALL SIZES, only 1 set of shapings will be shown on the first Chart and if you are knitting the 2nd or 3rd size, you simply follow the shapings as given for the first size. If the shapings are different, this will be shown on the Charts and you should follow them as given.

On the Charts, increases and decreases will be shown as follows

5x1
[6] The number in the box means number of ROWS between the shapings, while the 5x1 above the box means - 1 st. 5x... so you will increase or decrease 1 st. every 6th row 5x.

ARMHOLE SHAPINGS - NECK SHAPINGS - SHOULDER SHAPINGS - are made on every 2nd row UNLESS there is a number in a box along side or below the shapings. The rule is... where there is no box with a number, the shaping is made on every 2nd row.

THE PRINTED INSTRUCTIONS

You can follow the printed instructions or use them in combination with the Charts. Where there is any question in the printed instructions, you have the Charts to show you how the section will look.

The 3 sizes, with the different amounts of cast on stitches and the different shapings will look like this...

Cast on 124 (136) [148] sts. You will
Cast on 124 sts. for the first size.
Cast on 136 sts. for the 2nd size.
Cast on 148 sts. for the 3rd size.

The important thing to remember is that you MUST READ AHEAD so that you KNOW what to do for the size you are knitting. Sometimes where the number of stitches are the same but the number of times different, you will find shapings like this...

3 sts. 1x (2x) [3x], 2 sts. 1x (2x) [3x], 1 st. 3x (4x) [5x]. As you see, you MUST read ahead in order to follow the instructions as given for YOUR SIZE. The rows will be different for the different sizes in some cases... Shoulder and Neck shapings usually are worked at the SAME TIME for the back section - so watch for the words AT THE SAME TIME.

HOLDING STITCHES ON THE LEFT SIDE WHILE SHAPING THE RIGHT SIDE

When knitting a section of garment in stockinette stitch, it is easy to hold the stitches on the left side while knitting the right half, but when knitting a Pattern Stitch such as a Norwegian Design, a Holding Position Design, Weaving, etc., you should use the following method. For the NECK SHAPING, we tell you to bind off the center sts., put the needles on the left into holding position and complete the right half first.... so with a strand of contrast yarn, knit ALL of the left side stitches manually by hand, pulling each stitch back against the needle bed to the OUT OF WORK position. When the right side is completed, carefully pull the stitches held on contrast, forward into working position and as you do so, undo the contrast yarn, line up the needles (KNITTING machine owners, put the stitches under the sinkers) and complete the left half.

If you own a Japanese machine, you may find that when knitting the right half with the left side held in this way, the sinker plate will mark the left side while you are knitting the right half. To prevent this marking, you can tape a piece of paper over the knitting, underneath the sinkers, or if you own a Reversing Bar, you can hang this onto the Sinkers while you are knitting the right half. When hanging the Reversing Bar, be sure the eyes of the bar go BETWEEN the Sinker Posts on the upper part of the bar so that the tips of the bar only - show above the needle bed.

FULL FASHION DECREASING OR INCREASING

For Stockinette stitch, always use the Full Fashion method for increasing or decreasing.

TO DECREASE: Hang the 3rd stitch onto the 2nd stitch then move the stitches in to fill the empty needle.

TO INCREASE: Move the 2 end stitches 1 needle outward, then pick up the 3rd stitch from the row below and hang it onto the empty needle.

NORWEGIAN DESIGNS:

In the instructions, each row of the Norwegian Design is counted as 1 row but several movements of the Cam Box (or Slide) are needed to complete 1 row.

NORWEGIAN DESIGN WHEN USING THE PATTERN READER

When you use the Pattern Reader and knit a Norwegian Design using several colors, it is necessary to move the Trip Control Lever so that only 1 row registers.

FINISHING: Block all sections. For PULLOVERS, JACKETS, and DRESSES: Join front to back at sides and shoulders. Sew sleeves together and set in. Hem lower edge and sleeve edges if needed. For a double neckband or armhole band, sew 1 edge to the inside and 1 to the outside of neck or armhole. For a single ribbed band, sew 1 edge to the outside of neck or armhole edge. For a cardigan or jacket with buttonholes, finish buttonholes and sew on buttons.

PANTS: Join front to back at sides. Sew inside leg seams, then join center front and back. Make hem at waistline and insert elastic. Hem lower edge of pants legs.

THE SAMPLE SWATCH

Before you begin to knit any garment, you will need to knit a sample piece using the yarn you have chosen for your garment, so that you can check the stitch and row gauge which must measure the correct number of stitches and rows in 5 cm (2 inches).

For each Pattern in KNITTING MAGAZINE, we give you 3 tension numbers to work from and if you use the specified yarn for the garment, you should be able to get the correct stitch and row gauge using one of these numbers. Here is a very easy way to make your sample swatch and count the stitches and rows without actually counting, by using our KNITTING Converta Tape.

Supposing the Tension Numbers for the Stitch and Row Gauge are given as 5 to 7. Set the Tension Dial to the first number which is 5. With contrast waste yarn, and using the quick cast on method, cast on 60 stitches and knit 10 rows. Change to garment yarn and turn the Row Counter to 0. Knit 30 rows. Counting from each end, knit the 10th stitch on each side by hand with a small piece of contrast yarn. Leave the needles in working position and knit 30 rows (Row 60), then knit 4 rows with contrast waste yarn. Turn the Row Counter to 0 and the Tension Dial to 6 and with garment yarn, knit 30 rows. Mark the 10th stitch on each side as you did before, knit 30 rows, then 4 rows with contrast waste yarn. Turn the Row Counter to 0 and with Tension 7, repeat the above once more, ending with 10 rows of contrast waste yarn. Remove the work from the machine by passing the Slide across the needles without yarn (sometimes called 'dropping').

Pull and stretch the sample piece both lengthwise and diagonally from corner to corner, then lengthwise again. Do not count the stitches and rows immediately, but allow the sample to rest for several hours or even overnight. This will allow the stitches and rows to return to their basic form.

When your sample has rested and you are ready to count the stitches and rows, the KNITTING CONVERTA TAPE will do the counting for you without any counting on your part. Use the Tape as follows:

To measure the stitches, pull out the Tape to measure BETWEEN the 40 stitches in the center that you marked by hand knitting with contrast waste yarn - Push the red marker on the Tape so that it points to 40 stitches on the Tape. Your stitch gauge to 5 cm (2 inches) will shown in the red window on the tape. To find the number of rows in 5 cm (2 inches), place the tape to measure over 60 rows, push the red marker to 60 on the tape and your row gauge for 5 cm (2 inches) will show in the red window... Easy...? If you do not get the correct stitch and row gauge in the first part of your sample, then try the other two.

If you do not own a KNITTING CONVERTA TAPE, you must mark a 5 cm (2 inch) square in the center of the knitting, then count the number of stitches and rows within the square.

KK 422

GIRL'S SKIRT & JACKET

SIZES: Teen 6 (8) [10]

YARN: Allegro

GRAMS:

Skirt:			
Color 1	150	200	200
Color 2	100	150	150
Color 3	100	150	150
Color 4	50	100	100

Jacket:
Color 1 300 350 400

TENSION: 5 to 7

GAUGE: 14 sts. 21 rows = 5 cm (2")



Jacket is Stockinette stitch worn on the Purl side. Skirt is Stockinette stitch with color stripes. Worn on the Purl side.

FINISHING: Skirt: Weave the open sts. together then remove waste yarn. Fold pleats and baste in place. Sew one edge of waistband to inside and one to outside. Thread elastic through casing.

JACKET: See General Instructions. Fold facing and weave the open sts. then remove the waste yarn. Finish buttonholes and sew on buttons.

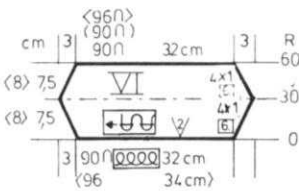
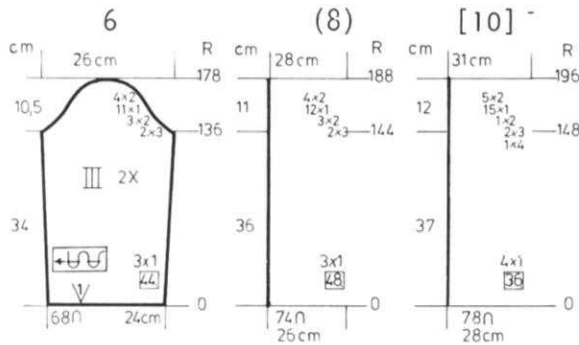

COLLAR:

With contrast waste yarn, cast on 90 (90) [96] sts. and work Stockinette stitch. Knit 8 to 10 rows, then change to garment yarn and put Counter at 0. ON EACH SIDE, increase 1 st. every 6th row 4x. After Row 30 (30) [34], ON EACH SIDE, decrease 1 st. every 6th row 4x. After Row 60 (60) [68], bind off loosely.

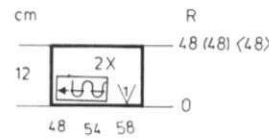
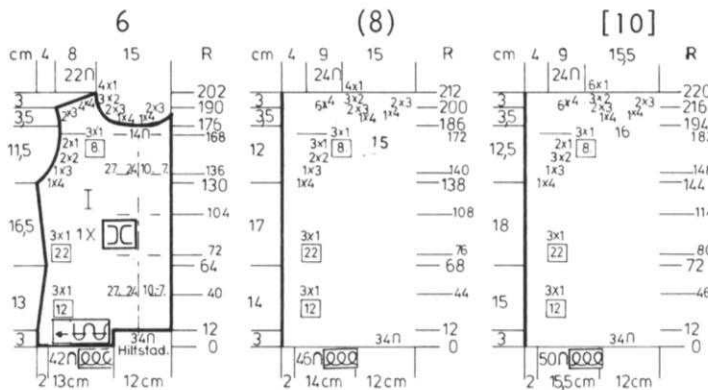

CUFFS:

Hang the open sts. of the sleeve back onto the machine, decreasing to 48 (54) [58] sts. Remove the waste yarn. Work Stockinette stitch to Row 48 then bind off.

SLEEVES: III

With contrast waste yarn, cast on 68 (74) [78] sts. and work Stockinette stitch. Knit 8 to 10 rows, change to garment yarn and put Counter at 0. ON EACH SIDE, increase 1 st. every 44th row 3x. (every 48th row 3x). [every 36th row 4x]. Knit to Row 136 (144) [148]. SHAPE CAP: ON EACH SIDE, bind off 3 sts. 2x, 2 sts. 3x, 1 st. 11x, 2 sts. 4x. (3 sts. 2x, 2 sts. 3x, 1 st. 12x, 2 sts. 4x). [4 sts. 1x, 3 sts. 2x, 2 sts. 1x, 1 st. 15x, 2 sts. 5x]. After Row 178 (188) [196], bind off the remaining sts.

FRONT: I Make 1, reverse 1.

Cast on 42 (46) [50] sts. and work Stockinette stitch. After Row 12, with waste yarn, cast on 34 sts. Continue with garment yarn over all the sts. ON SIDE EDGE, decrease 1 st. every 12th row 3x and after Row 40 (44) [46], make BUTTONHOLES over needles 7 to 10 and 24 to 27, counting from the right edge. Make the following Buttonholes over the same needles after the rows shown on the Chart for YOUR SIZE. After Row 64 (68) [72], ON SIDE EDGE, increase 1 st. every 22nd row 3x. Knit to Row 131 (139) [145]. SHAPE ARMHOLE: Bind off 4 sts. 1x, 3 sts. 1x, 2 sts. 2x, 1 st. 2x then increase 1 st. every 8th row 3x. (4 sts. 1x, 3 sts. 1x, 2 sts. 2x, 1 st. 3x, then increase 1 st. every 8th row 3x). [4 sts. 1x, 3 sts. 1x, 2 sts. 3x, 1 st. 2x, then increase 1 st. every 8th row 3x]. AT THE SAME TIME, after Row 176 (186) [194], leave 10 sts. on the right in holding position, bind off the next 14 (15) [16] sts., put the remaining sts. into holding position. Push the 10 sts. on the right (left for 2nd section into working position and on NECK SIDE, bind off 4 sts. 1x, 3 sts. 2x. Bring the needles on the left (right) into working position, turn the Row Counter back to 176 (186) [194] and ON NECK SIDE, bind off 4 sts. 1x, 3 sts. 2x, 2 sts. 3x, 1 st. 4x, and SHAPE SHOULDER same as the back after Row 191. (4 sts. 1x, 3 sts. 2x, 2 sts. 3x, 1 st. 4x and SHAPE SHOULDER same as the back after Row 201). [4 sts. 1x, 3 sts. 2x, 2 sts. 3x, 1 st. 6x and SHAPE SHOULDER SAME as the back after Row 209]. Work the 2nd section with reverse shaping, casting on from right to left. Cam Box will be on the LEFT side at Row 0. Omit the buttonholes.

JACKET BACK: II

Cast on 100 (106) [112] sts. with color 1 and work Stockinette stitch. After Row 12, ON EACH SIDE, decrease 1 st. every 16th row 3x. Knit to Row 64 (68) [72]. ON EACH SIDE, increase 1 st. every 22nd row 3x. Knit to Row 130 (138) [144]. SHAPE ARMHOLE: ON EACH SIDE, bind off 3 sts. 1x, 2 sts. 2x, 1 st. 3x. (3 sts. 1x, 2 sts. 2x, 1 st. 4x). [3 sts. 1x, 2 sts. 3x, 1 st. 3x]. Knit to Row 190 (200) [208]. SHAPE SHOULDER and watch for neck shaping. FOR SHOULDER, ON EACH SIDE, bind off 3 sts. 2x, 4 sts. 4x. (4 sts. 6x) [4 sts. 6x]. SHAPE NECK after Row 198 (208) [216]. Bind off the center 24 sts., put the needles on the left into holding position and complete the right side first. ON NECK SIDE, bind off 6 sts. 1x. (6 sts. 1x). [8 sts. 1x]. Move the Cam Box to the left side, turn the Row Counter back to 198 (208) [216] and complete the left half. Follow the instructions from * and don't forget to complete the shoulder shaping.

3			696
3			684
8			672
3			652
3			640
8			640
3			628
3			628
8			608
3			596
3			596
8			584
3			584
3			584
8			552
3			552
3			552
8			520
3			520
3			520
8			508
3			508
3			508
8			464
3			464
3			464
8			420
3			420
3			420
8			376
3			376
3			376
8			332
3			332
3			332
8			288
3			288
3			288
8			276
3			276
3			276
8			244
3			244
3			244
8			232
3			232
3			232
8			200
3			200
3			200
8			188
3			188
3			188
8			156
3			156
3			156
8			144
3			144
3			144
8			112
3			112
3			112
8			100
3			100
3			100
8			68
3			68
3			68
8			56
3			56
3			56
8			24
3			24
3			24
8			0
3			0
3			0

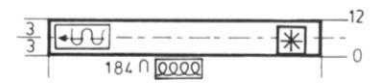

WAISTBAND:

Cast on 184 sts. with color 1 and work 12 rows of 2 rows color 1, 2 rows color 2, 4 rows color 3, 2 rows color 2, 2 rows color 1. Bind off loosely.

SKIRT:

With contrast waste yarn, cast on 178 (184) [190] sts. and work Stockinette stitch. Knit 8 to 10 rows, change to color 1 and put Counter at 0. Continue in Stockinette stitch with REPEATED color stripes as given below, but AT THE SAME TIME, after Row 12 and every following 44th row, knit 1 row with a DOUBLE STRAND OF YARN and after Row 24, and every following 44th row, mark each side with a small piece of contrast yarn (for the UNDER pleat). COLOR STRIPES: 4 rows color 1 2 rows color 2 2 rows color 3 2 rows color 4 2 rows color 1 2 rows color 2 2 rows color 3 REPEAT THE COLOR STRIPES from the beginning. After Row 608 (652) [696], knit 8 to 10 rows with contrast waste yarn and remove the work from the machine.

SEE PRINTED COPY

HP 423



MAN'S PULLOVER & SOCKS

SIZES: 38 (40) [42]
 YARN: Binia
 GRAMS: Pullover 500 550 600
 Socks 150 150 150
 TENSION: 7 to 9
 GAUGE: 14 sts. 19 rows = 5 cm (2")

Stockinette stitch with a Cable Design down left front section and center of sleeves and side of Socks. The knit side is the right side.

FINISHING: See General Instructions.

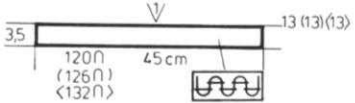

NECKBAND:

Cast on 120 (126) [132] sts. and work 13 rows K1, P1 Ribbing then bind off the crochet method for Ribbing.

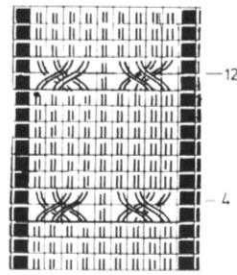

BACK: II

Cast on 134 (144) [152] sts. and work 24 rows K1, P1 Ribbing. Change to Stockinette stitch. Knit to Row 162 (168) [172]. SHAPE ARMHOLE: ON EACH SIDE, bind off 3 sts. 2x, 2 sts. 2x, 1 st. 3x. (3 sts. 2x, 2 sts. 3x, 1 st. 4x). [3 sts. 2x, 2 sts. 4x, 1 st. 3x]. Knit to Row 242 (246) [246]. Bind off the center 28 (32) [34] sts., put the needles on the left into holding position and complete the right side first. *ON NECK SIDE for all sizes, bind off 3 sts. 4x and AT THE SAME TIME, after Row 246 (252) [252], SHAPE SHOULDER: Bind off 5 sts. 4x, 4 sts. 2x. (5 sts. 4x, 4 sts. 2x). [5 sts. 6x]. Move the Cam Box to the left side, turn the Row Counter back to 242 (246) [246] and complete the left half. Follow the instructions from *.

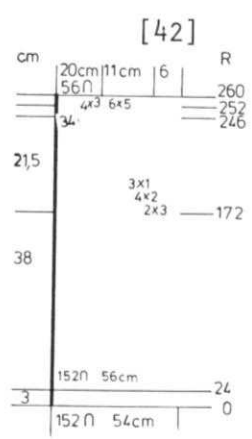
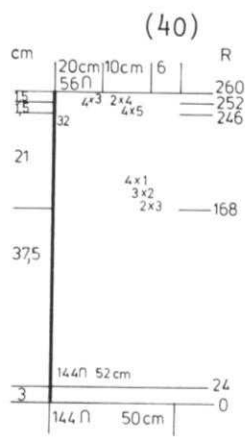
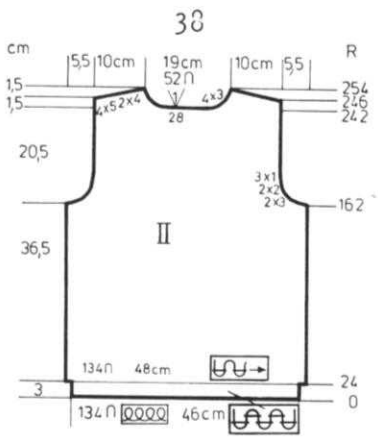

Continued



HP 423

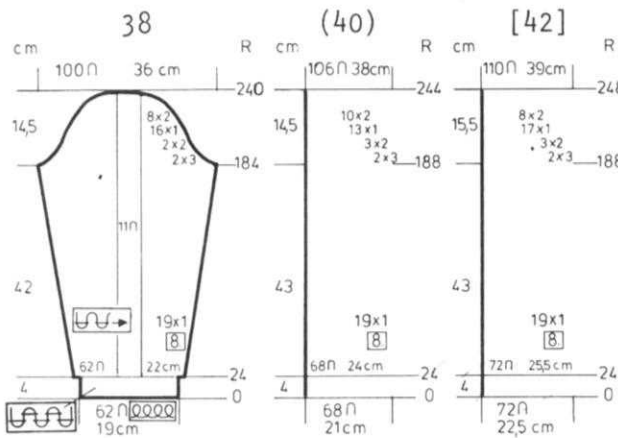

SLEEVES:

Cast on 62 (68) [72] sts. and work 24 rows K1, P1 Ribbing. Continue in Stockinette stitch with Cable Design over the center 11 sts. ON EACH SIDE, increase 1 st. every 8th row 19x. After Row 184 (188) [188], SHAPE CAP: ON EACH SIDE, bind off 3 sts. 2x, 2 sts. 2x, 1 st. 16x, 2 sts. 8x. (3 sts. 2x, 2 sts. 3x, 1 st. 13x, 2 sts. 10x). [3 sts. 2x, 2 sts. 3x, 1 st. 17x, 2 sts. 8x]. After Row 240 (248) [248], bind off the remaining sts.

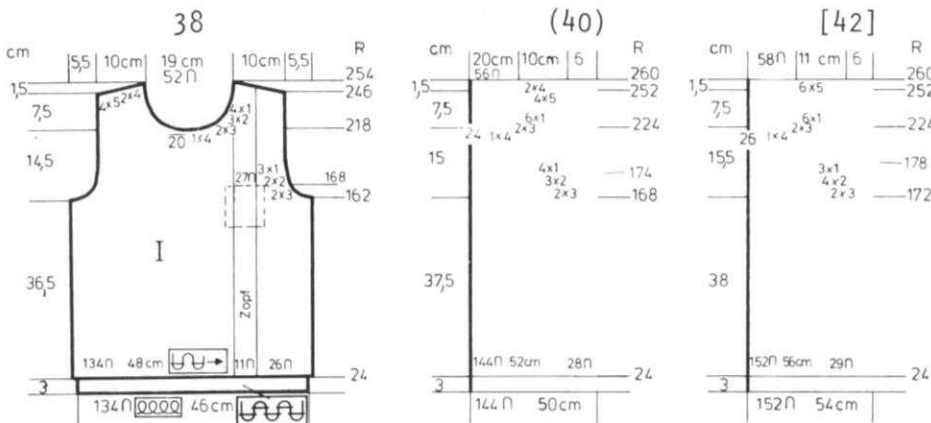

POCKET LINING:

Cast on 29 sts. and work 34 rows Stockinette stitch then remove the sts. onto contrast waste yarn.

FRONT: II

BE SURE TO COMPLETE THE POCKET LINING FIRST.

Cast on 134 (144) [152] sts. and work 24 rows K1, P1 Ribbing. Continue in Stockinette stitch with Cable Design. Follow the Line Drawing and work the Cable Design over needles 27 to 37 counting from the LEFT edge.

Knit to Row 162 (168) [172]. SHAPE ARMHOLE the same as the back but AT THE SAME TIME, after Row 168 (174) [178], remove the 11 sts. of the Cable Design plus 8 sts. ON EACH SIDE of these (27 sts.) onto a stitch holder and immediately hang the open sts. of the Pocket Lining onto these needles, remove the waste yarn and continue the Cable Design over the center 11 needles as before.

Knit to Row 218 (224) [224]. Bind off the center 20 (24) [26] sts. for neck, put the needles on the left side into holding position and complete the right side first.

*ON NECK SIDE, bind off 4 sts. 1x, 3 sts. 2x, 2 sts. 3x, 1 st. 4x and SHAPE SHOULDER same as the back after Row 246.

(4 sts. 1x, 3 sts. 2x, 1 st. 6x, and SHAPE SHOULDER same as the back after Row 252).

[4 sts. 1x, 3 sts. 2x, 1 st. 6x and SHAPE SHOULDER same as the back after Row 252].

Move the Cam Box to the left side, turn the Row Counter back to 218 (224) [224] and complete the left half. Follow the instructions from *.

Hang the open sts. of Pocket onto machine, transfer every other stitch to the Ribber and work 8 rows K1, P1 Ribbing then bind off the crochet method for Ribbing.

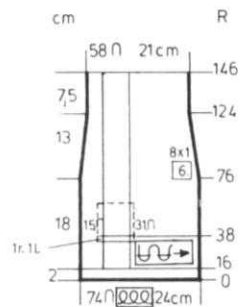

POCKET SOCKS: Make 2.

Cast on 74 sts. and work Stockinette stitch.

Knit to Row 16, then begin the Cable Design over needles 24 to 34 counting from the left edge (11 sts. for Cable Design). Knit to Row 38.

FOR POCKET, remove the 16th to 43rd sts., counting from the left onto a stitch holder, then with contrast waste yarn, cast on over these same needles and continue over all the needles with main yarn working the Cable Design.

After Row 76, ON EACH SIDE, decrease 1 st. every 10th row 5x. Knit to Row 145.

ON EACH SIDE, remove 16 sts. onto a stitch holder.

Stop the Cable Design and over the remaining 32 sts. knit 64 rows for the instep then work SHORT ROWS for the toe.

*ON OPPOSITE SIDE OF CAM BOX, put into holding position, 1 needle before knitting each row until 8 sts. remain in the center.

ON OPPOSITE SIDE OF CAM BOX, bring back into working position 1 needle before knitting each row until all are in work**.

Knit 64 rows for foot, then REPEAT the SHORT ROWS, following the instructions from * to ** for heel. Remove the sts. onto a stitch holder.

With purl side facing you, hang the open sts. of TOP of sock back onto the machine and remove the waste yarn. Knit 34 rows Stockinette stitch then bind off. (lining). With Purl side facing you, hang the open sts. of Pocket onto machine and transfer every other st. to the Ribber and work 6 rows K1, P1 Ribbing then bind off the crochet method for Ribbing.

Sew pocket lining in place and sew down Ribbed band. Weave the back leg seam on the very edge, then weave the open sts. of heel to to open sts. of leg and remove waste yarn. Make hem at top of sock and run elastic through casing.

Work the 2nd sock with the Cable Design on the RIGHT and omit pocket.



KK 424

GIRL'S PONCHO

SIZES: 5/6 (7/8) [9/10]
YARN: Fortissima (doubled yarn)
GRAMS: Color 1 550 600 650
Color 2 50 100 100
TENSION: 7 to 9
GAUGE: 10 sts. 14 rows = 5 cm (2")
OVER EVERY OTHER NEEDLE

Stockinette stitch OVER EVERY OTHER NEEDLE using Double Yarn. Purl side is the right side. Bands are over every needle with single yarn.

FINISHING: See General Instructions. Sew 1 edge of band to the outside and 1 to inside around all edges.

BACK: II Make 1, reverse 1.

Cast on 40 (44) [48] sts. over EVERY OTHER NEEDLE with color 1 and work Stockinette stitch.

On every 2nd row, ON SIDE EDGE, increase 1 st. 10x.

Knit to Row 64 (68) [70].

Make a BUTTONHOLE over needles 4 to 7 counting from the right (left for 2nd section) edge, then ON ARM SIDE, cast on 6 sts. 4x (7 sts. 4x) [7 sts. 4x].

After Row 74 (78) [80], decrease 1 st. every 3rd row 16x, every 2nd row 28x (7x) [8x], then every 2nd row, decrease 2 sts. 5x (22x) [23x], and for the first size only, bind off 3 sts. 2x and AT THE SAME TIME, watch for NECK SHAPING.

After Row 175 (179) [185], bind off 8 (9) [10] sts. for neck and on NECK SIDE, on every 2nd row, bind off 3 sts. 2x for all sizes.

Work the 2nd section with reverse shaping, casting on from right to left. Cam Box will be on the LEFT side at Row 0.

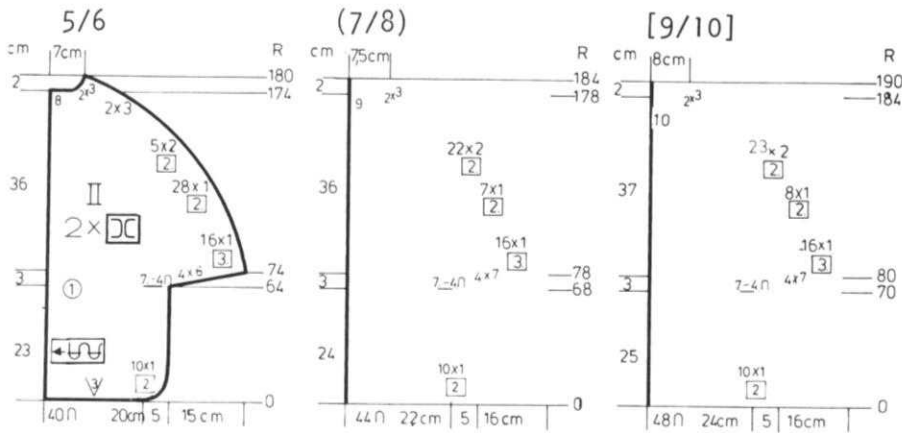

BAND TRIM: Lower the tension.

Cast on 14 sts. with color 2 (single strand) over every needle and work Stockinette stitch long enough to go around all edges (See picture).

FRONT: I Make 1, reverse 1.

DO NOT MAKE FRONT EDGE BUTTONHOLES IN THIS SECTION.

Cast on 46 (50) [54] sts. OVER EVERY OTHER NEEDLE with color 1 and work Stockinette stitch.

ON SIDE EDGE, increase 1 st. every 2nd row 10x.

Knit to Row 36 (38) [38].

Work the slanted POCKET opening as follows:

Put 12 (14) [14] sts. on the RIGHT (left for 2nd section) into holding position and using a new ball of yarn, decrease 1 st. every 3rd row 10x. Break the yarn, and put the remaining needles into hold-

ing position. Move the Cam Box to the right (left for 2nd section). Bring the 12 (14) [14] sts. into working position, turn the Row Counter back to 36 (38) [38] and increase 1 st. on the slit side every 3rd row 10x.

Bring the remaining needles back into working position and continue over all the needles.

After Row 66 (68) [70], work a BUTTONHOLE over needles 4 to 7 counting from the right (left for 2nd section) and on ARM SIDE, cast on 6 sts. 4x, 2 sts. 1x. (7 sts. 4x).

[7 sts. 4x]. After Row 74 (78) [80], ON ARM SIDE, decrease 1 st. every 3rd row 16x (16x) [16x], then decrease 1 st. every 2nd row 18x (18x) [8x], then every 2nd row, decrease 2 sts. (watch for neck shaping) 14x (16x) [23x].

AT THE SAME TIME, after Row 165. (169) [169], SHAPE NECK: Bind off 6 sts. 1x, 4 sts. 1x, 3 sts. 1x, 2 sts. 2x, 1 st. 3x.

(6 sts. 1x, 5 sts. 1x, 4 sts. 1x, 2 sts. 2x, 1 st. 3x). [6 sts. 1x, 4 sts. 1x, 3 sts. 1x, 2 sts. 3x, 1 st. 3x].

Work the 2nd section with reverse shaping, casting on from right to left. Cam Box will be on the LEFT side at Row 0 and MAKE BUTTONHOLES on FRONT EDGE over needles 5 & 6 counting from the right edge after the Rows shown on the Chart.

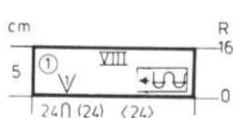

POCKET BANDS: VIII Make 2.

Cast on 24 sts. with color 1 (doubled yarn) over every other needle. Lower the tension and knit 16 rows Stockinette stitch then bind off.

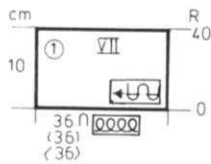

POCKET LINING: VII Make 2.

Cast on 36 sts. with single strand of color 1 over every needle and with lowered tension, knit 40 rows Stockinette stitch then bind off.

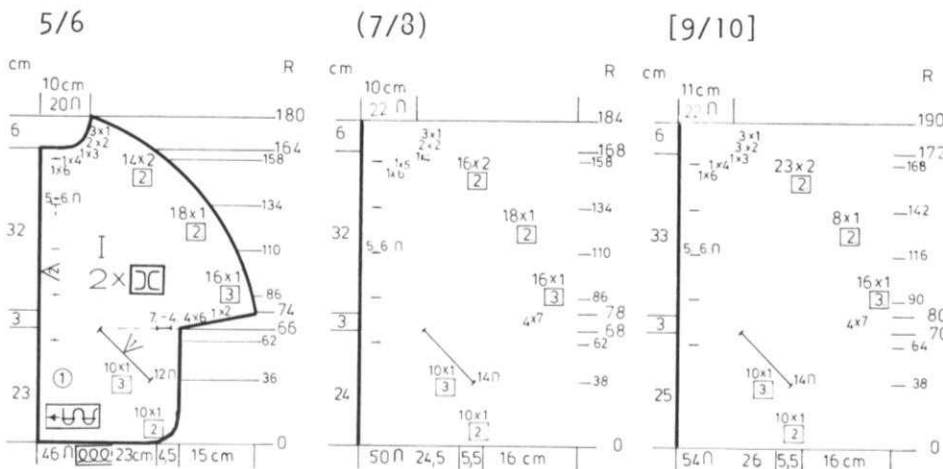

KK 425

BOY'S JACKET & PANTS

SIZES: 4/5 (6/7) [8/9]
YARN: Fortissima (doubled yarn over EVERY OTHER NEEDLE).
GRAMS:
 Color 1 600 (700) [750]
 Color 2 50 50 50
TENSION: 7 to 9
GAUGE:
 doubled yarn: 10 sts. 14 rows = 5 cm
 single yarn: 13 sts. 18 rows = 5 cm



The Jacket is knitted over EVERY OTHER NEEDLE with double strands of yarn. Pants & Bands are knitted over every needle with single strand of yarn. The Purl side is the right side.

FINISHING: See General Instructions. Sew Front and Neck band to outside of front and neck edges of Jacket. Sew in Jacket type zipper. Pants: Make a cord over 3 needles with tension 2 or 3 and knit long enough to thread through edges of leg bands and tie. (Optional - you may prefer to sew up the bands) Sew zipper down front of pants. Sew pocket bands to outside of pocket.

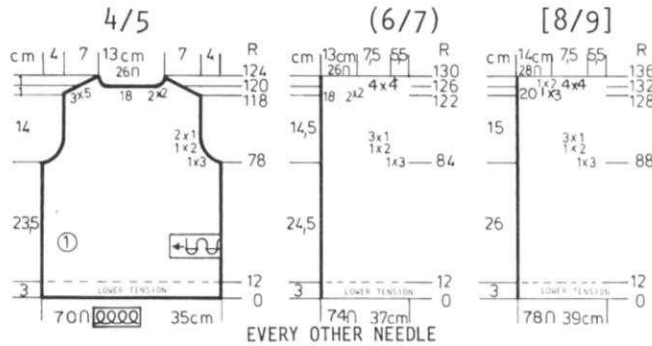

JACKET FRONT: I Make 1, reverse 1.

With DOUBLE STRANDS of color 1, cast on 34 (36) [38] sts. over EVERY OTHER NEEDLE and work Stockinette stitch. Lower the tension and knit to Row 12, then continue with garment tension.

Knit to Row 78 (84) [88].
SHAPE ARMHOLE: Bind off 3 sts. 1x, 2 sts. 1x, 1 st. 2x. (3 sts. 1x, 2 sts. 1x, 1 st. 3x). [3 sts. 1x, 2 sts. 1x, 1 st. 3x]. Knit to Row 107 (113) [113].

SHAPE NECK: Bind off 4 sts. 1x, 2 sts. 3x, 1 st. 2x, and **SHAPE SHOULDER** same as the back after Row 118. (4 sts. 1x, 2 sts. 3x, 1 st. 2x and **SHAPE SHOULDER** same as the back after Row 122).

[5 sts. 1x, 2 sts. 3x, 1 st. 3x, and **SHAPE SHOULDER** same as the back after Row 128].
 Work the 2nd section with reverse shaping, casting on from right to left. Cam Box will be on the LEFT side at Row 0.

JACKET BACK: II

With double strands of color 1, cast on 70 (74) [78] sts. over EVERY OTHER NEEDLE. Lower the tension and knit to Row 12. Change to garment tension and continue in Stockinette stitch. Knit to Row 78 (84) [88].
SHAPE ARMHOLE: ON EACH SIDE, bind off 3 sts. 1x, 2 sts. 1x, 1 st. 2x. (3 sts. 1x, 2 sts. 1x, 1 st. 3x). [3 sts. 1x, 2 sts. 1x, 1 st. 3x]. Knit to Row 118 (122) [128].
SHAPE SHOULDER and watch for Neck Shaping:
FOR SHOULDER, ON EACH SIDE, bind off

5 sts. 3x. (4 sts. 4x). [4 sts. 4x].
FOR NECK: After Row 120 (126) [132], bind off the center 18 (18) [20] sts. put the needles on the left into holding position and complete the right side first.
 *ON NECK SIDE, bind off 2 sts. 2x. (2 sts. 2x). [3 sts. 1x, 2 sts. 1x]. Move the Cam Box to the left side, turn the Row Counter back to 120 (126) [132] and complete the left half. Follow the instructions from * and don't forget to complete the shoulder shaping.

FRONT & NECK BAND:

Cast on 10 sts. with color 2 over every needle and work Stockinette stitch for as long as you need. Remove on waste yarn so that you may pull out any extra rows.

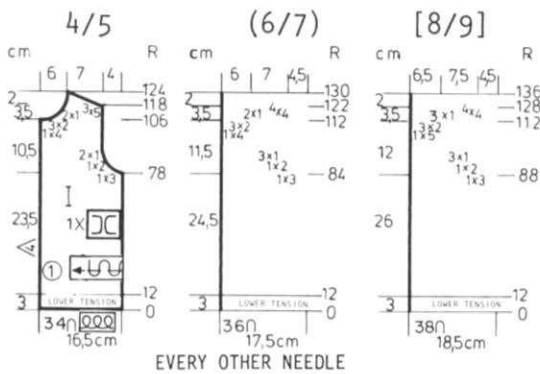

PANTS BACK: Make 1, reverse 1.

With contrast waste yarn, cast on 42 (48) [52] sts. over every needle and work Stockinette stitch. Knit 8 to 10 rows, then continue with color 1 and put Counter at 0. ON EACH SIDE, increase 1 st. every 10th row 6x. ON INSIDE LEG EDGE, increase 1 st. every 4th row 13x. Knit to Row 97 (111) [115].
SHAPE CROTCH: Bind off 4 sts. 1x, 3 sts. 2x, 2 sts. 3x, 1 st. 4x, then every 4th row 1 st. 4x, (4 sts. 1x, 3 sts. 2x, 2 sts. 4x, 1 st. 4x, then every 4th row 1 st. 4x), [4 sts. 1x, 3 sts. 2x, 2 sts. 4x, 1 st. 4x, then every 4th row 1 st. 4x].

AND AT THE SAME TIME, after Row 128 (140) [148], cast on 28 sts. on the right (left for 2nd section), and after Row 150 (160) [168], decrease 2 sts. for DART; the first time, hang the 53rd and 55th sts. onto the 54th st. counting from the right (left) edge. Decrease 2 sts. for DART every 8th row 3x more. After Row 172 (184) [192], bind off the remaining sts.

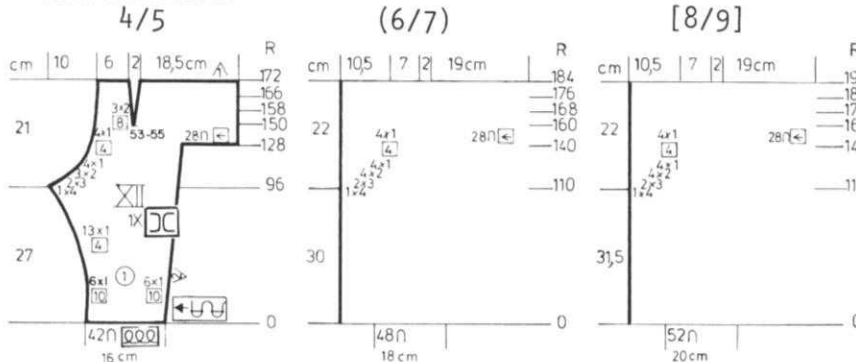

PANTS WAISTBAND

Cast on 136 (150) [160] sts. over every needle with color 1 and work Stockinette stitch to Row 18. Bind off.

PANTS POCKET TRIM:

With single strand of color 2, cast on 10 sts. over every needle. Work Stockinette stitch for as long as you need.

SLEEVES: III

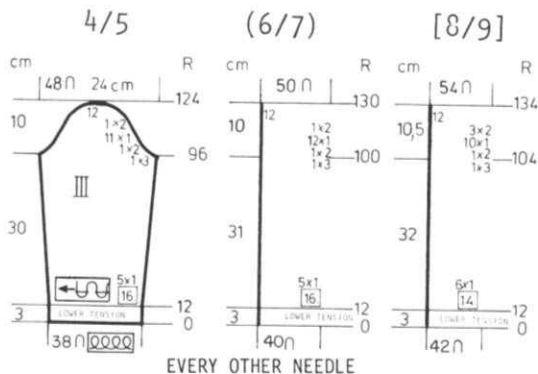

With DOUBLE STRANDS of color 1, cast on 38 (40) [42] sts. over EVERY OTHER NEEDLE and work Stockinette stitch. Lower the tension and knit to Row 12 then continue with garment tension. ON EACH SIDE, increase 1 st. every 16th row 5x (5x) [every 14th row 6x]. Knit to Row 96 (100) [104]. SHAPE CAP: ON EACH SIDE, bind off 3 sts. 1x, 2 sts. 1x, 1 st. 11x, 2 sts. 1x. (3 sts. 1x, 2 sts. 1x, 1 st. 12x, 2 sts. 1x). [3 sts. 1x, 2 sts. 1x, 1 st. 10x, 2 sts. 3x]. After Row 124 (130) [134], bind off the remaining sts.

PANTS FRONT: XI Make 1, reverse 1.

With contrast waste yarn, cast on 38 (44) [50] sts. and work Stockinette stitch. Knit 8 to 10 rows then change to color 1 and put Counter at 0. Knit to Row 50. ON THE RIGHT (left for 2nd section), increase 1 st. every 6th row 4x, every 4th row 4x. After Row 96 (110) [114], on the RIGHT (left), decrease 1 st. every 2nd row 8x (9x) [9x]. After Row 112 (126) [132], cast on 5 sts. Knit to Row 149 (159) [165]. SHAPE POCKET: Bind off 6 sts. 1x, 4 sts. 1x, 2 sts. 3x, 1 st. 3x. (8 sts. 1x, 4 sts. 1x, 2 sts. 3x, 1 st. 3x). [8 sts. 1x, 4 sts. 1x, 2 sts. 3x, 1 st. 4x]. After Row 172 (184) [192], bind off the remaining sts.

KK 426

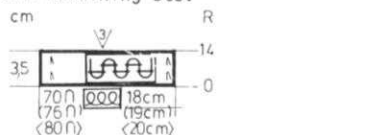
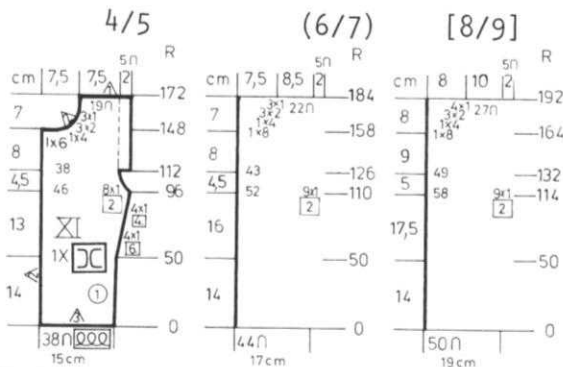

Sew the inside leg seams together, then hang the open sts. of leg onto machine, decreasing to 70 (76) [80] sts. Transfer every other stitch to the Ribber and work 14 rows K1, P1 Ribbing then bind off the crochet method for Ribbing.

FINISHING: See General Instructions. Sew peplum to lower edge of jacket. Embroider flowers on front as shown on picture. Work crochet around lower edge of jacket and sleeves and around neckline and front edges.
 ROW 1: With color 1, single crochet.
 ROW 2: With color 2, work 2 half double crochet in first st. *ch 1, skip 1, 2 half double crochets in next st. REPEAT from *.
 ROW 3: With color 1, single crochet. *Work 1 sc between half double crochet, ch 1 and REPEAT from *.
 Make a cord over 4 sts. and work for as long as you need. Thread through eyelets and tie.

JACKET BACK: II

With contrast waste yarn, cast on 86 (92) [98] sts. and work Stockinette stitch. Knit 8 to 10 rows, change to garment yarn and put Counter at 0. Knit 4 rows then make eyelets across. Hang every 6th st. onto 7th st. and leave empty needles in working position and ON EACH SIDE, on every 6th row, increase 1 st. 7x (8x) [every 10th row 8x]. Knit to Row 74 (76) [84]. SHAPE ARMHOLE: ON EACH SIDE, bind off 2 sts. 3x, 1 st. 2x. (3 sts. 1x, 2 sts. 2x, 1 st. 3x). [3 sts. 1x, 2 sts. 2x, 1 st. 3x]. Knit to Row 124 (128) [136]. SHAPE SHOULDER and watch for NECK SHAPING: FOR SHOULDER, bind off 5 sts. 4x, 4 sts. 1x. (5 sts. 4x, 6 sts. 1x). [6 sts. 4x, 4 sts. 1x]. FOR NECK, after Row 128 (132) [140], bind off the center 18 (18) [20] sts., put the needles on the left into holding position and complete the right side first. *ON NECK SIDE, bind off 3 sts. 3x for all sizes.
 Move the Cam Box to the left side, turn the Row Counter back to 128 (132) [140] and complete the left half. Follow the instructions from * and don't forget to complete the shoulder shaping.

GIRL'S SKIRT & JACKET

SIZES: 6 (7/8) [9/10]
 YARN: Fortissima
 GRAMS: Color 1 450 500 550
 Color 2 50 50 100
 TENSION: 6 to 8
 GAUGE: 14 sts. 19 rows = 5 cm (2")

Stockinette stitch worn on the knit side. Small amounts of a 3rd color for embroidery on front of jacket.

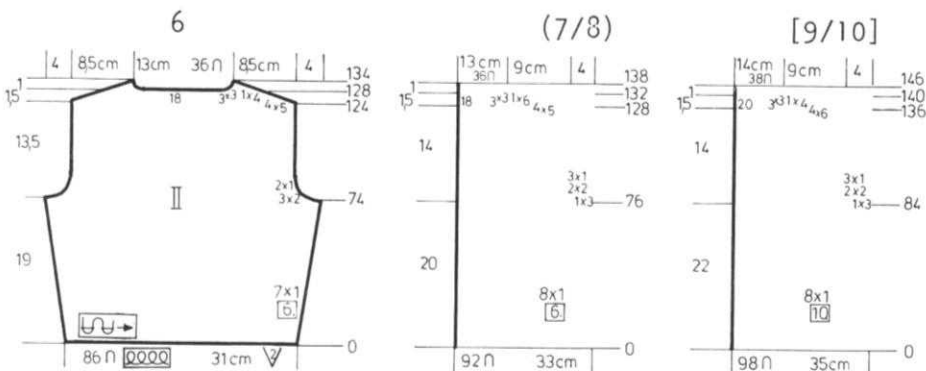

Continued

KK 426

JACKET FRONT: I Make 1, reverse 1

DO NOT MAKE BUTTONHOLES IN THIS SECTION.

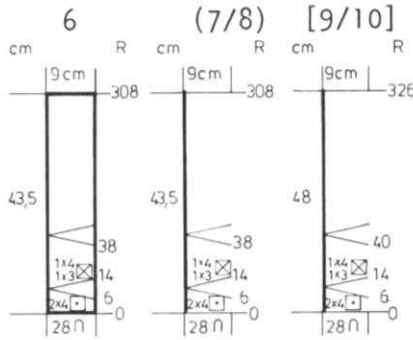

PEPLUM:

Cast on 28 sts. and work Stockinette stitch with Short Rows. Knit to Row 6.
 *ON OPPOSITE SIDE OF CAM BOX, put into holding position, 4 sts. 2x. ON OPPOSITE SIDE OF CAM BOX, bring back into working position, 3 sts. 1x, 4 sts. 1x. Bring the last needle into work and knit 24 rows.**
 REPEAT from * to ** to Row 308 (308) [326]. Bind off.

With contrast waste yarn, cast on 49 (52) [55] sts. and work Stockinette stitch. Knit 8 to 10 rows then change to garment yarn and put counter at 0.
 Knit 4 rows, then make eyelets across as you did on the back and ON SIDE EDGE, increase 1 st. every 6th row 7x (8x) [every 8th row 8x].
 Knit to Row 75 (77) [85].
 SHAPE ARMHOLE: Bind off 3 sts. 1x, 2 sts. 2x, 1 st. 3x. (3 sts. 1x, 2 sts. 2x, 1 st. 3x). [3 sts. 1x, 2 sts. 2x, 1 st. 3x].
 Knit to Row 112 (114) [120].
 SHAPE NECK: Bind off 4 sts. 2x, 3 sts. 2x, 2 sts. 2x, 1 st. 4x.
 (4 sts. 2x, 3 sts. 2x, 2 sts. 2x, 1 st. 6x).
 [4 sts. 2x, 3 sts. 3x, 2 sts. 3x, 1 st. 5x].

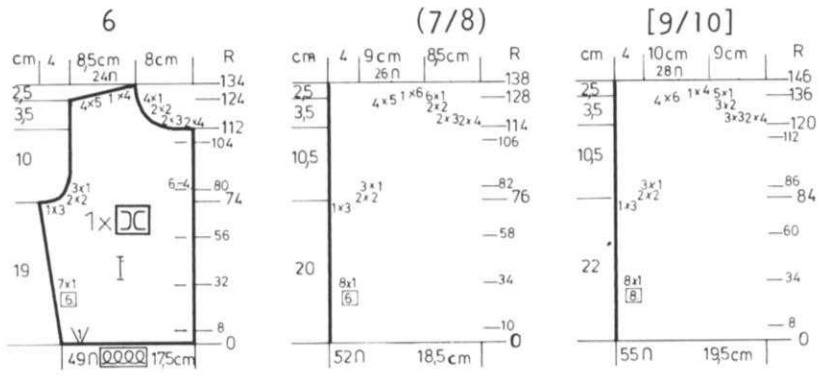

SLEEVE: III

Cast on 50 (56) [58] sts. and work Stockinette stitch.
 ON EACH SIDE, increase 1 st. every 12th row 10x.
 Knit to Row 132 (138) [146].
 SHAPE CAP: ON EACH SIDE, bind off 3 sts. 1x, 2 sts. 2x, 1 st. 7x, 2 sts. 7x.
 (3 sts. 2x, 2 sts. 2x, 1 st. 7x, 2 sts. 7x).
 [3 sts. 2x, 2 sts. 2x, 1 st. 10x, 2 sts. 6x].
 After Row 166 (174) [186], bind off the remaining sts.

GIRL'S SKIRT

FRONT & BACK: (2 sections the same).

With color 2, cast on 168 (176) [180] sts. and work Stockinette stitch. Lower the tension for 10 rows. Work the color stripes as shown on the Chart.
 After Row 50, continue with color 1 and work the side and DART decreases at the SAME TIME.
 ON EACH SIDE, decrease 1 st. every 12th row 11x, and AT THE SAME TIME decrease 2 sts. FOR EACH DART every 10th row 13x. For the first DART decrease, ON EACH SIDE, hang the 33rd and 35th sts. onto the 34th needle and move the sts. in to fill the empty needles. The following DART decreases lie directly above.
 After Row 170 (178) [184], transfer every other stitch to the Ribber and work K1, P1 Ribbing to Row 178 (186) [192]. Bind off the crochet method for Ribbing.

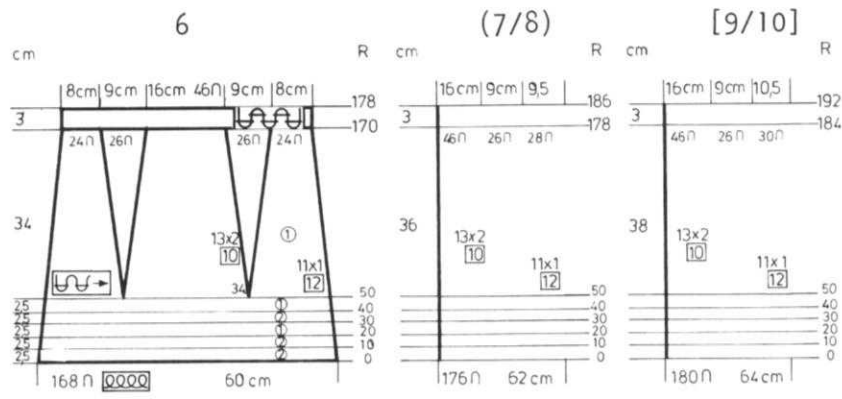
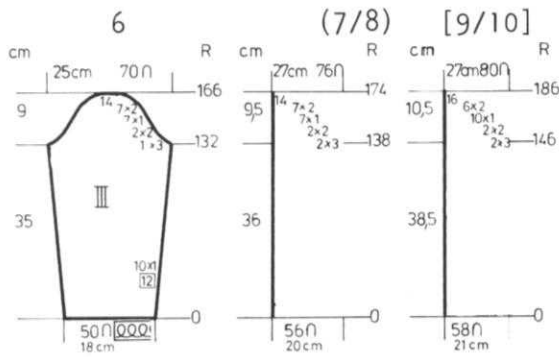

BE SURE TO NOTIFY US IMMEDIATELY OF ANY CHANGE OF ADDRESS. THE POST OFFICE WILL NOT FORWARD YOUR MAGAZINE TO YOU.

DK 427



WOMAN'S COAT

SIZES: 7/8 (10/12)
 YARN: Summertime
 GRAMS: 900 1000
 TENSION: 7 to 9
 GAUGE: 11 sts. 21 rows = 5 cm (2")

Stockinette stitch worn on the Purl side.

FINISHING: See General Instructions.

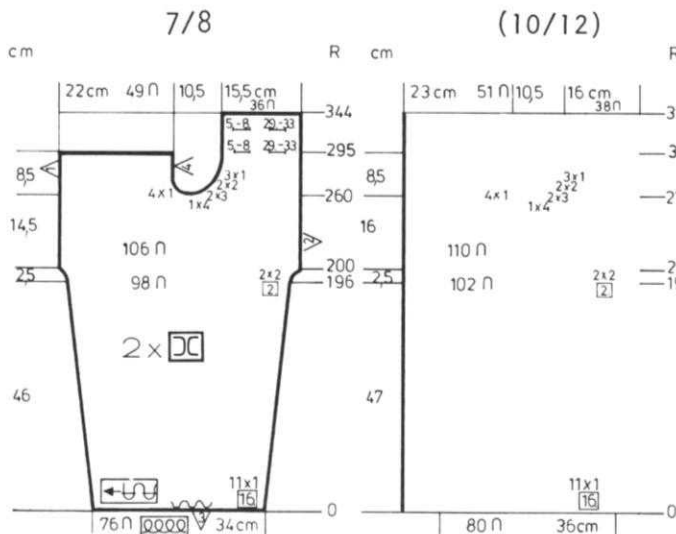

YOKE & SLEEVES: Make 1, reverse 1 and omit the buttonholes.

Begin at sleeve edge and with contrast waste yarn, cast on 76 (80) sts. Knit 8 to 10 rows, change to garment yarn and put Counter at 0. Work Stockinette stitch.
 ON EACH SIDE, increase 1 st. every 16th row 11x.
 After Row 196 (198), ON EACH SIDE, cast on 2 sts. 2x.
 Knit to Row 260 (270).
 Put 53 (55) sts. on the left (right for 2nd section) into holding position, knit across, then on NECK SIDE bind off 4 sts. 1x, 3 sts. 2x, 2 sts. 2x, 1 st. 3x.
 After Row 295 (305) make BUTTONHOLES over needles 5 to 8 and 29 to 33 counting from the LEFT edge. Knit to Row 335 (345) and make BUTTONHOLES over the same needles as before.
 After Row 344 (354) bind off.
 Bring the needles on the left into working position, attach yarn and put Row Counter back to 260 (270).
 ON EVERY 2nd row, on NECK SIDE, bind off 1 st. 4x.
 Knit to Row 295 (305). Bind off.
 Work the 2nd section with reverse shaping, casting on from right to left. Cam Box will be on the LEFT side at Row 0. Omit the buttonholes.

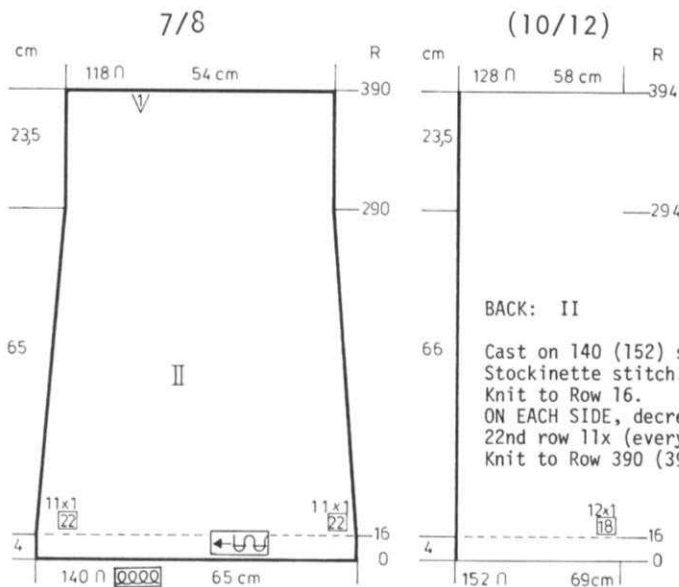

Cast on 140 (152) sts. and work Stockinette stitch.
 Knit to Row 16.
 ON EACH SIDE, decrease 1 st. every 22nd row 11x (every 18th row 12x)
 Knit to Row 390 (394). Bind off.

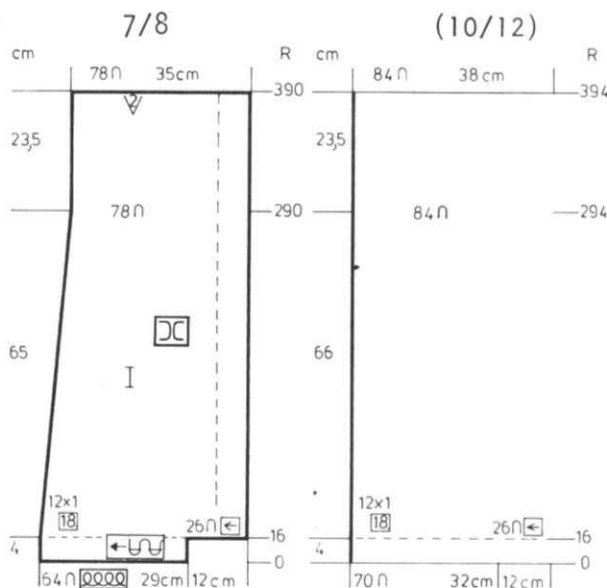

FRONT: I Make 1, reverse 1.

Cast on 64 (70) sts. and work Stockinette stitch.
 Knit to Row 16, then cast on 26 sts. on the right (left for 2nd section).
 ON SIDE EDGE, decrease 1 st. every 18th row 12x.
 Knit to Row 390, then bind off.
 Work the 2nd section with reverse shaping, casting on from right to left. Cam Box will be on the LEFT side at Row 0.

SLEEVE CUFFS:

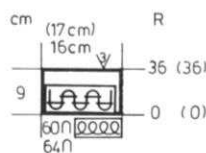

With Cam Box on the LEFT side, hang the sts. of the sleeve back onto the machine, decreasing to 60 (64) sts. Knit 1 row to the right side in stockinette stitch. Transfer every other stitch to the Ribber and work 36 rows K1, P1 Ribbing. Bind off the crochet method for Ribbing.

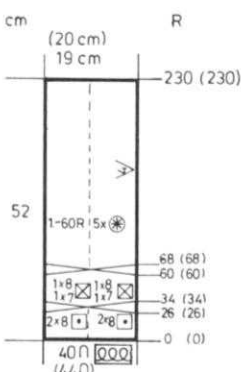

COLLAR: With contrast waste yarn, cast on 40 (44) sts. and work Stockinette stitch. Knit 8 to 10 rows then change to garment yarn and put Counter at 0.
 After Row 26, work SHORT ROWS:
 ON OPPOSITE SIDE OF CAM BOX, put into holding position, 8 sts. 2x ON EACH SIDE.
 ON OPPOSITE SIDE OF CAM BOX, bring back into working position 7 sts. 1x, 8 sts. 1x. (push back the last needle before knitting the following 2 rows). REPEAT ROWS 0 to 34 5x more (Row 204) then knit even to Row 230. Remove the sts. onto waste yarn.

DK 428

WOMAN'S COAT

SIZES: 8/10 (12/14)
 YARN: Euro Sport
 GRAMS: 1000 1200
 TENSION: 9 or 10
 GAUGE: 12 sts. 17 rows = 5 cm (2")

Stockinette stitch worn on the Purl side. Fisherman's Rib for Collar and Bands. (Brioche)
 FINISHING: See General Instructions.

BE SURE TO KNIT THE FRONT AND BACK SIDE PANELS FIRST.

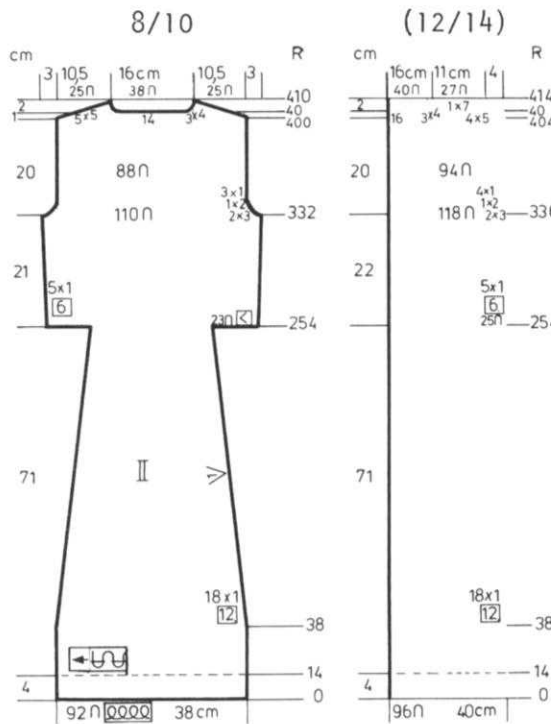

BACK: II

Cast on 92 (96) sts. and work Stockinette stitch.
 Knit to Row 38.
 ON EACH SIDE, decrease 1 st. every 12th row 18x.
 Knit to Row 254.
 ON EACH SIDE, remove 1 st. onto pin or yarn (for seam) and with PURL SIDE FACING YOU, hang the 23 sts. of EACH SIDE SECTION onto the machine with the 1 st. free on the inside (for seam). Remove the waste yarn and continue.
 ON EACH SIDE, increase 1 st. every 6th row 5x.
 Knit to Row 332 (336).
 SHAPE ARMHOLE: ON EACH SIDE, bind off 3 sts. 2x, 2 sts. 1x, 1 st. 3x. (3 sts. 2x, 2 sts. 1x, 1 st. 4x).
 Knit to Row 400 (404).
 Bind off the center 14 (16) sts., put the needles on the left into holding position and complete the right side first.
 *SHAPE SHOULDER AND NECK AT THE SAME TIME.
 FOR SHOULDER, bind off 5 sts. 5x. (5 sts. 4x, 7 sts. 1x).
 FOR NECK, bind off 4 sts. 3x for both sizes.
 Move the Cam Box to the left side, turn the Row Counter back to 400 (404) and complete the left half. Follow the instructions from *.

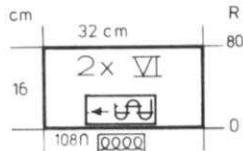

FRONT: I Make 1, reverse 1 and omit the buttonholes.

Cast on 42 (48) sts. and work Stockinette stitch.
 After Row 14, cast on 24 sts. on the right (left for 2nd section).
 ON SIDE EDGE, after Row 38, decrease 1 st. every 12th row 18x for both sizes BUT AT THE SAME TIME, ON FRONT EDGE, make BUTTONHOLES over needles 5 to 8 and 17 to 20 counting from the right edge after the rows shown on Chart.

After Row 254, ON SIDE EDGE, remove 1 st. onto a pin or yarn as you did for back, then hang the side front section with purl side facing you onto 23 needles leaving the 1 st. free on inner edge. Remove the waste yarn and continue.

ON SIDE EDGE, increase 1 st. every 6th row 5x.
 Knit to Row 332 (338).
 Leave 7 sts. on the right (left for 2nd section) in working position and put all the rest of the sts. into holding position.

ON NECK SIDE, decrease 1 st. every 4th row 3x, every 2nd row 4x.

Turn the Row Counter back to 332 (338). ON NECK SIDE, bind off 12 sts. then SHAPE NECK AND ARMHOLE AT THE SAME TIME.
 FOR ARMHOLE, bind off 4 sts. 1x, 3 sts. 1x, 2 sts. 1x, 1 st. 2x.
 (4 sts. 1x, 3 sts. 1x, 2 sts. 2x, 1 st. 3x).

FOR NECK, decrease 1 st. every 4th row 19x. (every 2nd row 7x, every 4th row 16x).

SHAPE SHOULDER same as the back after Row 401 (407).
 Work the 2nd section with reverse shaping, casting on from right to left. Cam Box will be on the LEFT side at Row 0 and omit the buttonholes.

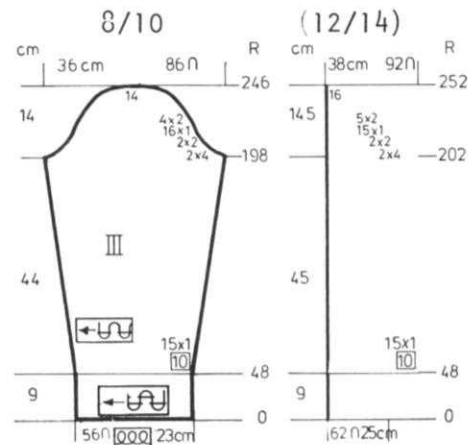

SLEEVES: III

Cast on 56 (62) sts. and work 56 Rows double Fisherman's (Brioche) Rib.
 Continue in Stockinette stitch.
 ON EACH SIDE, increase 1 st. every 10th row 15x.
 Knit to Row 198 (202).
 SHAPE CAP: ON EACH SIDE, bind off 4 sts. 2x, 2 sts. 2x, 1 st. 16x, 2 sts. 4x.
 (4 sts. 2x, 2 sts. 2x, 1 st. 15x, 2 sts. 5x).
 After Row 246 (252), bind off the remaining sts.

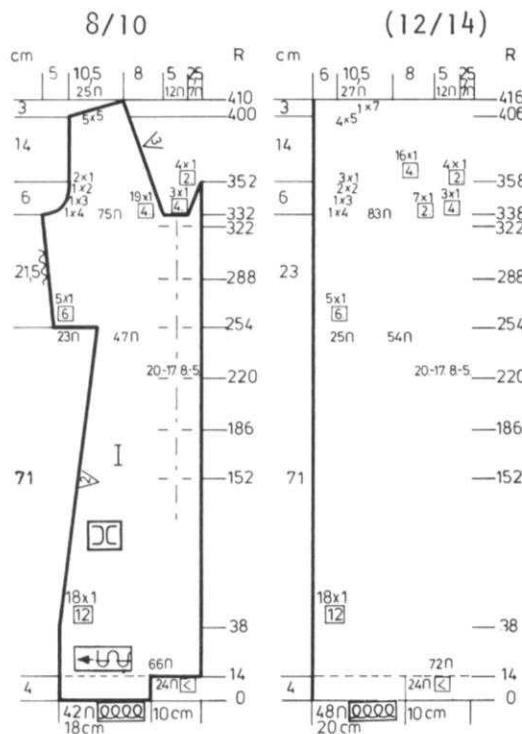

BACK SIDE PANEL: II Make 1, reverse 1.

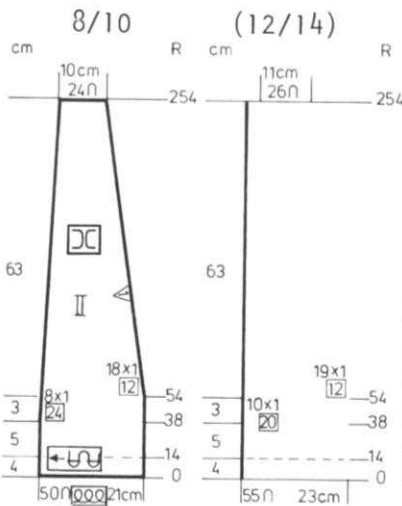

Cast on 50 (55) sts. and work Stockinette stitch.
Knit to Row 38.
ON THE LEFT (right for 2nd section) decrease 1 st. every 24th row 8x (10th row 20x)
AND AT THE SAME TIME, after Row 54, on the RIGHT (left for 2nd section) decrease 1 st. every 12th row 18x (19x).
After Row 254, remove the right end st. (left for 2nd section) onto a pin or bright color yarn.
Remove the remaining sts. onto contrast waste yarn. (the single stitch is for seam).
Work the 2nd back panel with reverse shaping taking the left end stitch off onto pin or yarn before removing the remaining sts on waste yarn.

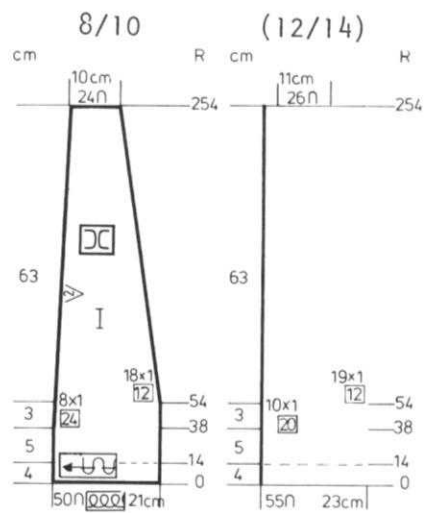

FRONT SIDE PANELS: Make 1, reverse 1.

Cast on 50 (55) sts. and work Stockinette stitch.
Make the 2 sections for the side front exactly the same as you did the back panels - reversing 1 and removing the one st. (for seam) on each section in the same way before taking the remaining sts. off onto waste yarn.

DK 429

WOMAN'S JACKET

SIZES: 16 (18) [20]
YARN: Micaela
Color 1 200 250 300
Color 2 150 200 200
TENSION: 6 to 8
GAUGE: 12 sts. 26 rows = 5 cm (2") in Pattern.

AM 3 KNITTING machines - A Holding Position Design using Wheel No. 3.
Punch Card machines - A Tuck Stitch.
Punch your own Card. Worn on the pur1 side.

FINISHING: See General Instructions.
Sew in a bust dart on front sections.

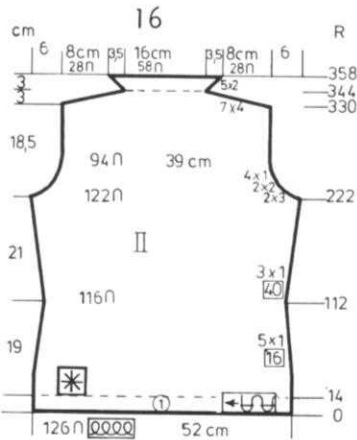

BACK: II

Cast on 126 (132) [140] sts. with color 1 and work Stockinette st.
Knit to Row 14, then continue in Pattern.
ON EACH SIDE, decrease 1 st. every 16th row 5x.
After Row 112, increase 1 st. every 40th row 3x.
Knit to Row 222 (226) [226].
SHAPE ARMHOLE: ON EACH SIDE, bind off
3 sts. 2x, 2 sts. 2x, 1 st. 4x.
(3 sts. 2x, 2 sts. 2x, 1 st. 5x).
[4 sts. 1x, 3 sts. 1x, 2 sts. 3x, 1 st. 4x].
Knit to Row 330 (336) [336].

SHAPE SHOULDER: ON EACH SIDE
bind off
4 sts. 7x.
(5 sts. 6x).
[5 sts. 5x, 6 sts. 1x].
ON EACH SIDE, on every 2nd row,
cast on 2 sts. 5x.
After Row 358 (362) [362], bind off
the remaining 58 (58) [60] sts.
loosely.

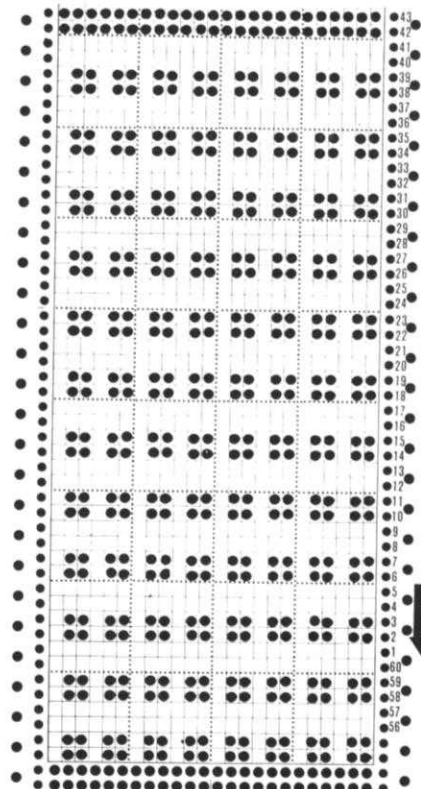
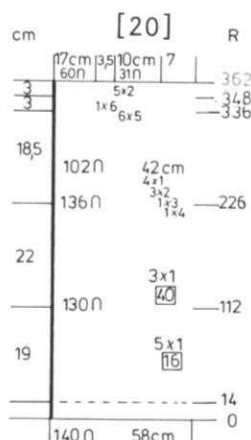
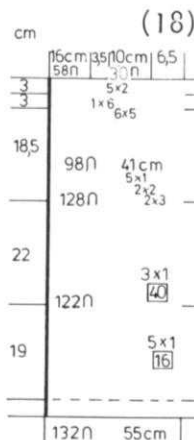

AM 3 KNITTING machines. Use Wheel No. 3. *Dial 3, knit 2 rows color 1. All needles in work, knit 2 rows color 2. REPEAT from *.

Punch Card Machines:



*Push in BOTH Tuck Buttons, knit 2 rows color 1.
Release Tuck Buttons, knit 2 rows color 2. REPEAT from *.

Continued

DK 429

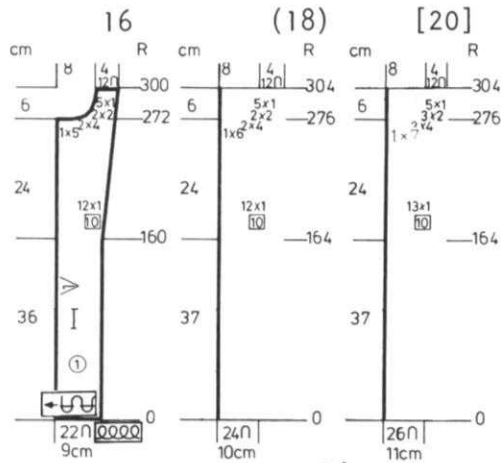

FRONT FACING: I Make 1, reverse 1.

Cast on 22 (24) [26] sts. with color 1 and work Stockinette stitch. Knit to Row 160 (164) [164]. ON CAM BOX SIDE, increase 1 st. every 10th row 12x (12x) [13x]. After Row 273 (277) [277], ON NECK SIDE, bind off 5 sts. 1x, 4 sts. 2x, 2 sts. 2x, 1 st. 5x. (7 sts. 1x, 4 sts. 2x, 2 sts. 2x, 1 st. 5x). [8 sts. 1x, 4 sts. 2x, 2 sts. 3x, 1 st. 5x]. After Row 300 (304) [304], bind off the remaining sts.

FRONT: I Make 1, reverse 1.

Cast on 48 (54) [58] sts. with color 1 and work Stockinette stitch. Knit to Row 14, then cast on 20 sts. on the right side (left for 2nd section). Continue in Pattern. ON SIDE EDGE, decrease 1 st. every 16th row 5x. After Row 112, ON SIDE EDGE, increase 1 st. every 40th row 3x. (every 40th row 3x). [every 36th row 4x]. Knit to Row 235 (239) [239]. SHAPE ARMHOLE and watch for neck shaping. Bind off 4 sts. 1x, 3 sts. 2x, 2 sts. 3x, 1 st. 4x, then increase 1 st. every 20th row 3x. (4 sts. 1x, 3 sts. 2x, 2 sts. 4x, 1 st. 4x, then increase 1 st. every 20th row 3x). [4 sts. 1x, 3 sts. 3x, 2 sts. 1x, 1 st. 5x, then increase 1 st. every 20th row 2x]. AT THE SAME TIME, after Row 330 (336) [336], SHAPE NECK: Bind off 5 sts. 1x, 4 sts. 2x, 2 sts. 2x, 1 st. 4x, and SHAPE SHOULDER same as the back after Row 343. (6 sts. 1x, 4 sts. 2x, 2 sts. 2x, 1 st. 4x and SHAPE SHOULDER same as the back after Row 349). [6 sts. 1x, 4 sts. 2x, 2 sts. 3x, 1 st. 5x, and SHAPE SHOULDER same as the back after Row 349].

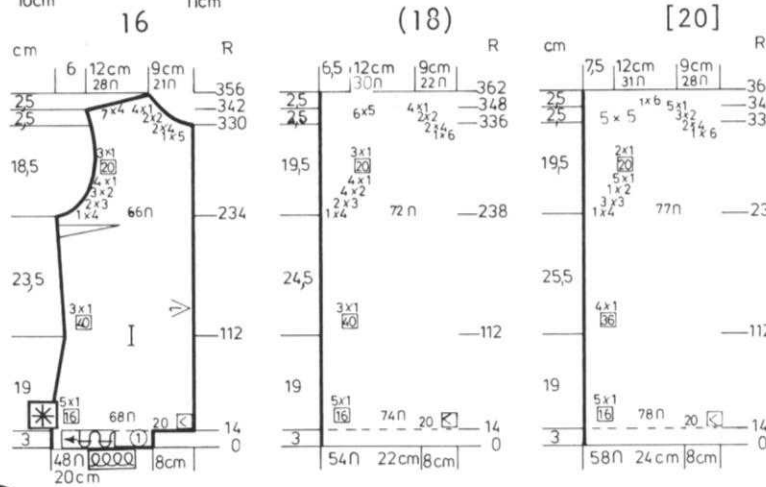

DK 430



WOMAN'S SKIRT

SIZES: 16 (18) [20]
YARN: Micaela
GRAMS: 300 350 400
TENSION: 6 to 8
GAUGE: 14 sts. 23 rows = 5 cm (2")

Stockinette stitch knitted sideways on the machine and using Short Rows. Worn on the Purl side.

FINISHING: Weave the open sts. together then remove waste yarn. Fold over 5 cm (2") at waist and hem. Thread elastic thru casing.

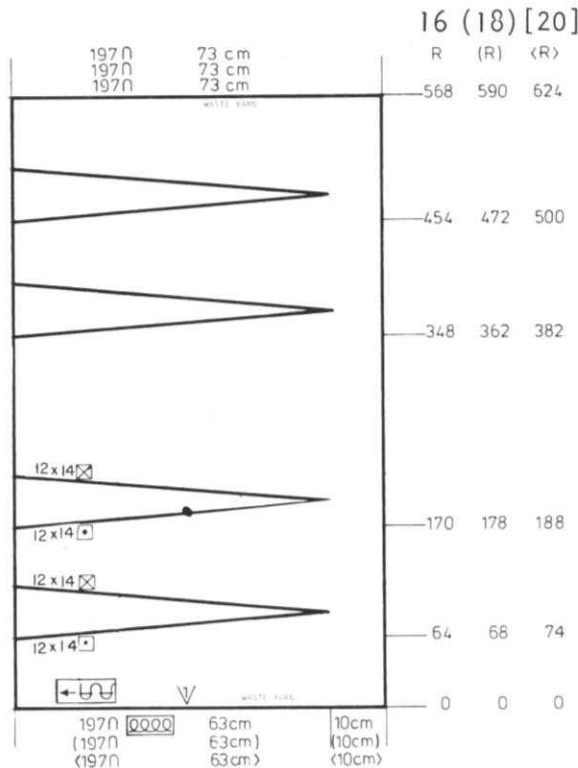

With contrast waste yarn, cast on 197 sts. Knit 8 to 10 rows, then change to garment yarn and put Counter at 0. Knit to Row 64 (68) [74]. Work SHORT ROWS: *ON OPPOSITE SIDE OF CAM BOX, put into holding position 14 sts. 12x. Bring all the needles back into working position and knit 2 rows over all the needles with a DOUBLE STRAND OF YARN. Put ALL but 29 stitches on the RIGHT into holding position - do not knit, but immediately bring back into working position, 14 sts. Continue with a SINGLE strand of yarn, knit 2 rows. Continue to bring 14 sts. back into work and knit 2 rows until all are in working position**. Knit to Row 170 (178) [188]. REPEAT THE SHORT ROWS from * to **. Knit to Row 348 (362) [382]. REPEAT THE SHORT ROWS from * to **. Knit to Row 454 (472) [500]. REPEAT THE SHORT ROWS from * to **. Knit to Row 568 (590) [624]. Knit 8 to 10 rows with contrast waste yarn and remove the sts. from the machine.

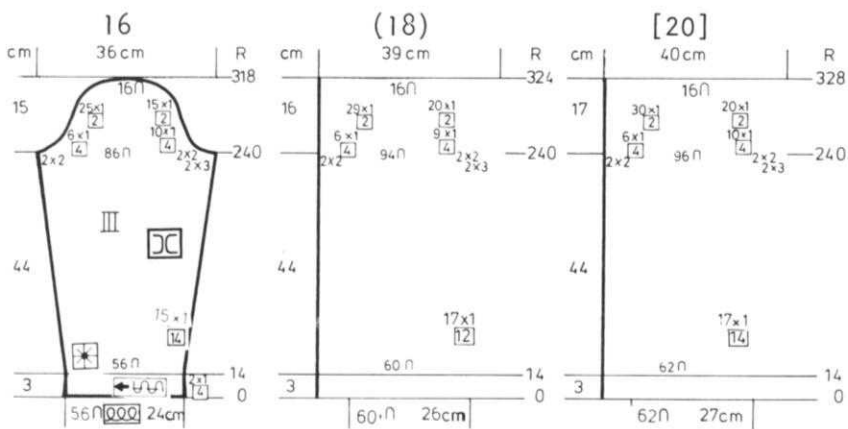

SLEEVES: III

Cast on 56 (60) [62] sts. with color 1 and work 14 rows Stockinette stitch. Continue in Pattern and ON EACH SIDE, increase 1 st. every 14th row 15x. (every 12th row 17x). [every 12th row 17x]. After Row 240, SHAPE CAP: PLEASE FOLLOW THE CHART for the CAP SHAPING, working the different bind-offs for each side. After Row 318 (324) [328], bind off the remaining sts.

DK 431

WOMAN'S SKIRT

SIZES: 18/20 (22) [24]
YARN: Summertime
GRAMS: 450 500 550
TENSION: 8 to 10
GAUGE: 11 sts. 21 rows = 5 cm (2")

*knit 1 row, reverse the knitting and REPEAT from * for 10 or 12 rows (garter stitch)... OR you may pick up the open sts. onto a knitting needle and work the garter stitch by hand. Another way is to work several rows of single crochet around the lower edge.

Stockinette stitch worn on the Purl side.

FINISHING: There are several ways to finish the lower edge of the Skirt. You may.. begin with garment yarn and knit 26 rows Stockinette stitch with a lower tension ... or you may begin with waste yarn and knit the skirt sections, then hang the open sts. back onto the machine with knit side facing you,

FRONT & BACK: (2 sections the same).

With contrast waste yarn, cast on 138 (142) [142] sts. and work Stockinette stitch. Knit 8 to 10 rows, change to garment yarn and put counter at 0. Knit to Row 40. ON EACH SIDE, decrease 1 st. every 22nd row 7x. (every 24th row 6x). [every 40th row 2x]. After Row 194, ON EACH SIDE, decrease 1 st. (watch for DARTS), every 14th row 6x, (every 18th row 5x), [every 12th row 7x]. AT THE SAME TIME, after Row 230, decrease 2 sts. for EACH DART every 14th row 4x. For the first DART decreases, ON EACH SIDE, hang the 27th & 29th sts. onto the 28th sts. and move the sts. in to fill the empty needles. The following DART decreases lie directly above. After Row 284, bind off the remaining sts.

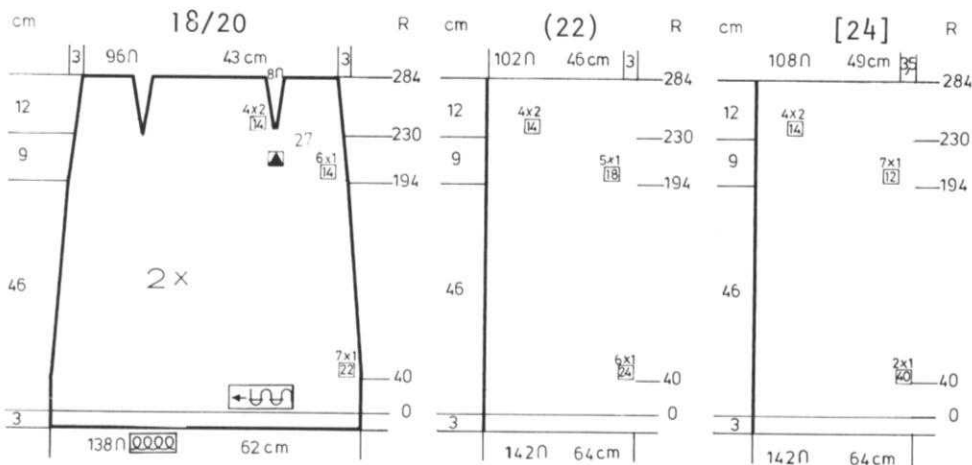

DK 432

WOMAN'S TUNIC

SIZES: 18/20 (22) [24]
YARN: Summertime
GRAMS:
 Color 1 200 250 250
 Color 2 200 250 250
 Color 3 150 200 200
TENSION: 8 to 10
GAUGE: 11 st. 19 rows = 5 cm (2"0)

Stockinette stitch with REPEATED Color Stripes. Worn on the Purl side. Bands are K1, P1 Ribbing.

FINISHING: See General Instructions. Weave the open sts. of sides together, then remove waste yarn. Sew short ends of bands together. Sew 1 edge of arm bands to armhole. Sew the longer edge of neck band to neckline.

Work the REPEATED COLOR STRIPES AS FOLLOWS:

- 2 rows color 2
- 2 rows color 3
- 2 rows color 2
- 2 rows color 3
- 2 rows color 2
- 2 rows color 3
- 2 rows color 2
- 8 rows color 1

REPEAT from the beginning.



Continued



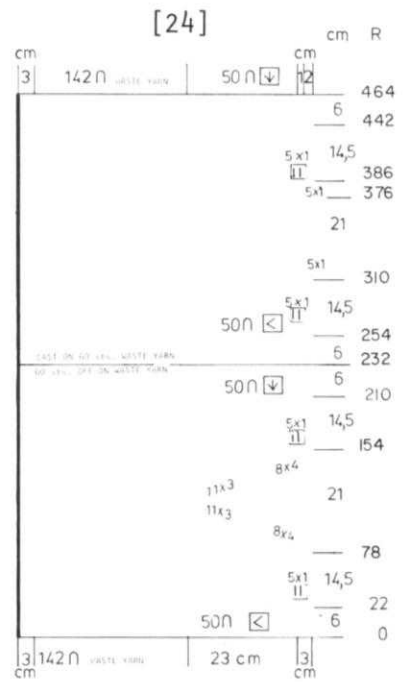
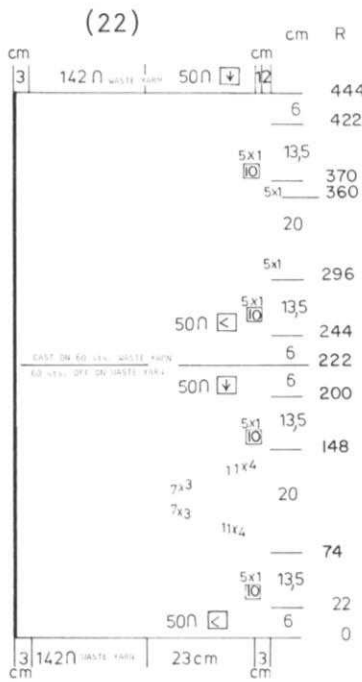
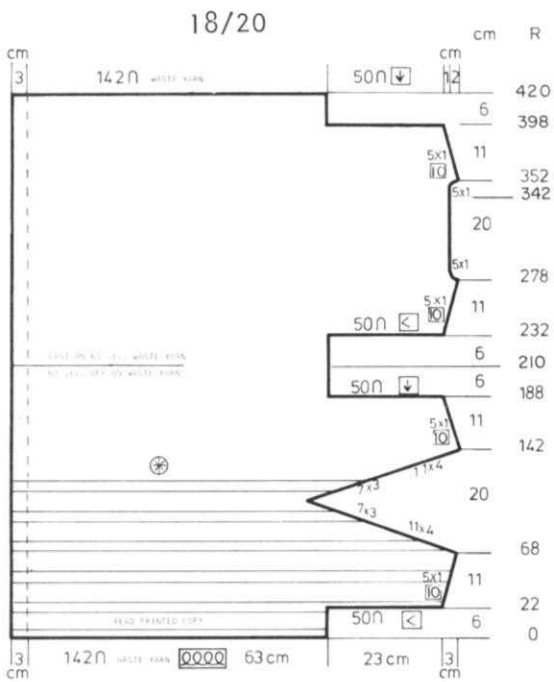

DK 432

To the extreme left of machine, with contrast waste yarn, cast on 142 sts. Knit 8 to 10 rows, change to color 1 and put Counter at 0. Continue in Stockinette stitch with color stripes BEGINNING WITH 4 ROWS COLOR 1. After Row 22, cast on 50 sts. on the RIGHT and on every 10th (10th) [11th] row, increase 1 st. 5x. After Row 68 (74) [78], SHAPE NECK: Bind off 4 sts. 11x, 3 sts. 7x. (4 sts. 11x, 3 sts. 7x). [4 sts. 8x, 3 sts. 11x]. ON NECK SIDE, cast on 3 sts. 7x, 4 sts. 11x. (3 sts. 7x, 4 sts. 11x). [3 sts. 11x, 4 sts. 8x]. After Row 142 (148) [154],

SHAPE SHOULDER: Decrease 1 st. every 10th (10th) [11th] row 5x. After Row 188 (200) [210], SHAPE ARMHOLE: Bind off 50 sts. After Row 210 (222) [232], On the LEFT, remove 60 sts. onto waste yarn and immediately cast on the 60 sts. with waste yarn. After Row 232 (244) [254], cast on 50 sts. SHAPE SHOULDER: On every 10th (10th) [11th] row, increase 1 st. 5x. After Row 278 (296) [310], SHAPE NECK: Bind off 1 st. 5x for all sizes. After Row 342 (360) [376], cast on 1 st. 5x. After Row 352 (370) [386], SHAPE SHOULDER: On every 10th (10th) [11th] row, decrease 1 st. 5x. After Row 398 (422) [442], bind off 50 sts. After Row 420 (444) [464], remove the sts. onto waste yarn.

ARMBANDS: Make 2.

Cast on 140 sts. with color 1 and work 8 rows K1, P1 Ribbing then bind off the crochet method for Ribbing.

NECKBAND:

Cast on 180 sts. with color 1 and work K1, P1 Ribbing. ON EACH SIDE on every 2nd row, decrease 1 st. After Row 8, bind off the crochet method for Ribbing. Weave front 'V' together then sew to neckline.

SIDE SLIT FACINGS:

With pur1 side facing you, work 1 side of slit at a time. Skip 14 sts. at hem edge, then pick up 46 sts. and work 10 rows Stockinette stitch with color 1. Bind off. Repeat for other side slit before weaving the seams together. Fold the facings to the inside and weave the open edges of side and hem.

DK 435

WOMAN'S JACKET

SIZES: 7/8 (10/12) [14/16]
YARN: Yarn 1 = Summertime
Yarn 2 = Vienna
GRAMS:
Yarn 1 500 550 600
Yarn 2 200 200 200
TENSION: 8 to 10
GAUGE: 11 sts. 22 rows = 5 cm (2")

Stockinette stitch worn on the Pur1 side. Bands are K1, P1 Ribbing with Yarn 2 used for the Collar and front bands.

FINISHING: See General Instructions.

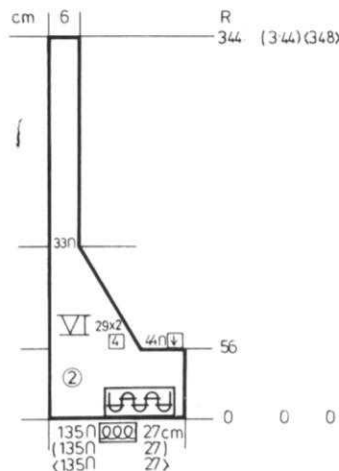

COLLAR & FRONT FACING: Make 1, reverse 1. USE TENSION 4.

Cast on 135 sts. with Yarn 2 and work K1, P1 Ribbing. (Tension 4). Knit to Row 56. Bind off 44 sts. on the right (left for 2nd section). ON EVERY 4th ROW, bind off 2 sts. 29x. Knit to Row 344 (344) [348] then bind off the remaining sts.

Continued 28



DK 434



WOMAN'S DRESS & SHAWL

SIZES: 8/10 (12/14)
YARN: Color 1 = Micaela
 Color 2 = Capriccio

GRAMS: DRESS
 Color 1 300 350
 Color 2 250 300

GRAMS: SHAWL
 Color 2 200 200

TENSION: 5 to 7
GAUGE: Dress: 15 sts. 19 rows = 5 cm
 Shawl: 12 sts. 21 rows = 5 cm

Stockinette stitch and a Norwegian Design. Punch your own Card or follow the illustration of Punch Card.

FINISHING: With right sides together, sew bodice lining to dress around neckline and armhole (do front and back separately). Leave shoulder and sides open. Turn lining to the wrong side, then sew lining side seams and seams of dress. For Straps, cast on 8 sts and knit Stockinette st. for as long as you need. Fit straps into opening (see picture) fold in edges, to round off or point and invisibly sew to straps. Make hem at lower edge.

SHAWL: Single crochet 2 rows around all edges. For fringe, Wind yarn around a 10" Cardboard and cut at one end only. Use 5 or 6 strands, fold in half and pull through edge of shawl, spacing about one inch apart. Make 2 rows of knots 1 1/2" down taking half the strands from first group and half from 2nd group of fringe then alternating for the next row of knots. (See picture).

SHAWL:

To the extreme left of machine, cast on 4 sts. with color 2 and work Stockinette stitch.

ON THE RIGHT, on every 2nd row, *cast on 1 st. 1x, 2 sts. 1x, and REPEAT from * 19x more, then cast on 2 sts. 1x, and 1 st. 84x (150 sts.).

After Row 250, bind off 1 st. 84x, then 2 sts. 1x, *2 sts. 1x, 1 st. 1x and REPEAT from * 19x more. After Row 500, bind off the remaining 4 sts.

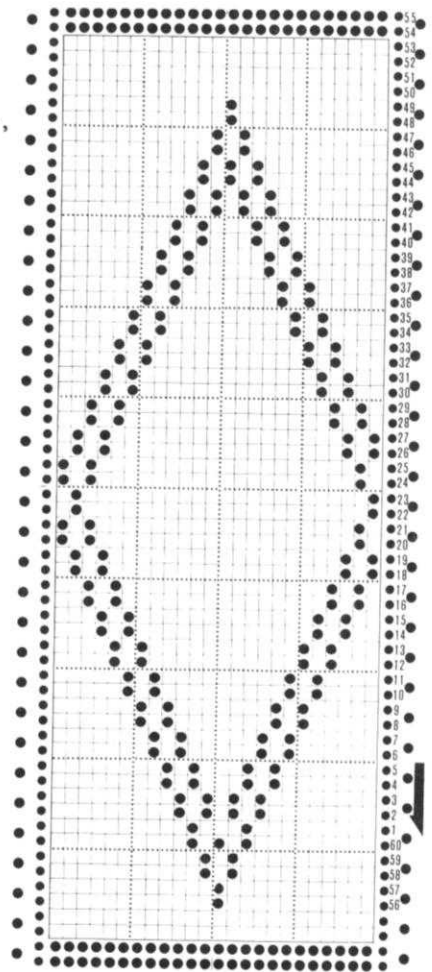
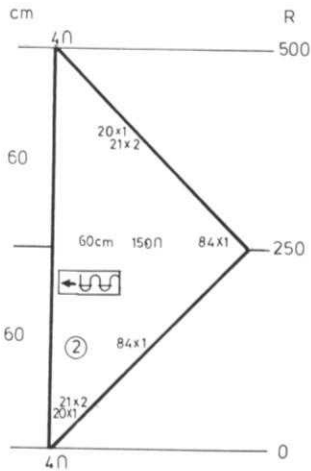

8/10

(12/14)

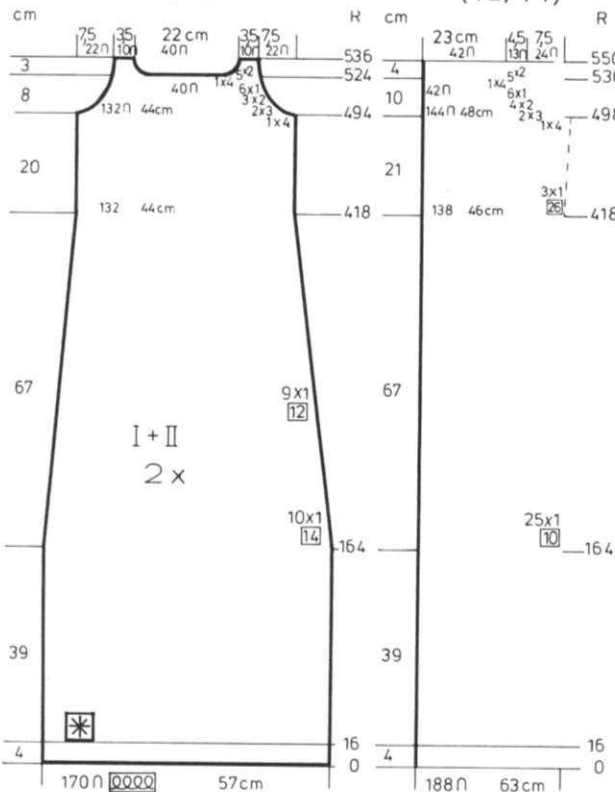

8/10

(12/14)

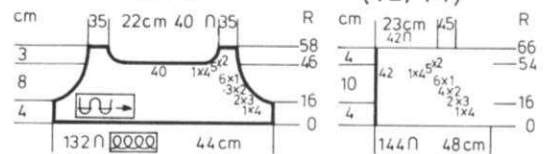

DRESS FRONT & BACK (2 sections the same)

Cast on 170 (188) sts. with color 1 and work 16 rows Stockinette stitch. Continue in the Norwegian Design. Knit to Row 164.

ON EACH SIDE, decrease 1 st. every 14th row 10x, every 12th row 9x. (every 10th row 25x).

Knit to Row 418.

FOR 2nd SIZE ONLY, ON EACH SIDE, increase 1 st. every 26th row 3x. Knit to Row 494 (498).

SHAPE ARMHOLE: ON EACH SIDE, bind off 4 sts. 1x, 3 sts. 2x, 2 sts. 3x, 1 st. 6x. (4 sts. 1x, 3 sts. 2x, 2 sts. 4x, 1 st. 6x).

Knit to Row 524 (536).

Bind off the center 40 (42) sts., put the needles on the left into holding position and complete the right side first.

*ON NECK SIDE, bind off 4 sts. 1x, 2 sts. 5x for all sizes.

After Row 536 (550) bind off the remaining 10 (13) sts.

Bring the needles on the left into working position, knit 1 row in Pattern to the left side, turn the Row Counter back to 524 (536) and complete the left half. Follow the instructions from *.

BODICE FACING: Make 2.

Cast on 132 (144) sts. with color 1 and work Stockinette stitch. Knit to Row 16.

SHAPE ARMHOLE same as the dress and after Row 46 (54), bind off the center 40 (42) sts., put the needles on the left into holding position and complete the right side first.

*ON NECK SIDE, bind off 4 sts. 1x, 2 sts. 5x for both sizes.

After Row 58 (66), bind off the remaining 10 (13) sts.

Move the Cam Box to the left side, turn the Row Counter back to 46 (54) and complete the left half. Follow the instructions from *.

DK 435

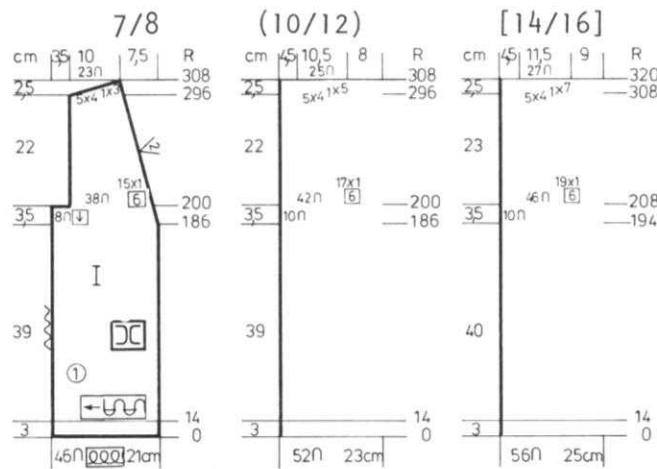

FRONT: I Make 1, reverse 1

Cast on 46 (52) [56] sts. with Yarn 1 and work 14 rows K1, P1 Ribbing. Continue in Stockinette stitch. Knit to Row 186 (186) [194]. SHAPE NECK AND ARMHOLE AT THE SAME TIME.

FOR NECK: ON EVERY 6th row, decrease 1 st. 15x (17x) [19x].

FOR ARMHOLE: After Row 201 (201) [209], bind off 8 (10) [10] sts. After Row 297 (297) [309], SHAPE SHOULDER same as the back.

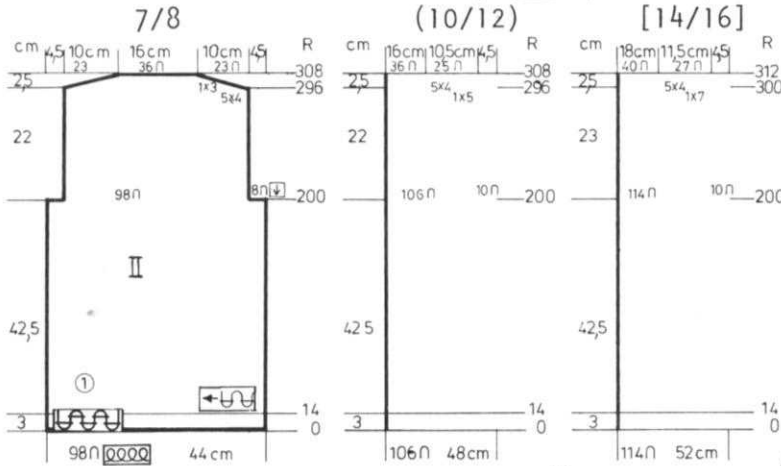

BACK: II

Cast on 98 (106) [114] sts. with Yarn 1 and work 14 rows K1, P1 Ribbing. Continue in Stockinette stitch.

Knit to Row 200.

SHAPE ARMHOLE: ON EACH SIDE, bind off 8 (10) [10] sts.

Knit to Row 296 (296) [300].

SHAPE SHOULDER: ON EACH SIDE, bind off

4 sts. 5x, 3 sts. 1x.

(5 sts. 1x, 4 sts. 5x).

[7 sts. 1x, 4 sts. 5x].

After Row 308 (308) [312], bind off the remaining sts.

HP 436



MAN'S JACKET

SIZES: 34/36 (38) [40/42]

YARN: Vienna

GRAMS: Color 1 350 400 450

Color 2 150 150 200

TENSION: 5 to 7

GAUGE: Stock: 15 sts. 24 rows = 5 cm (2")

Pat: 16 sts. 20 rows = 5 cm (2")

Stockinette stitch with a Norwegian Design using 2 different patterns. Punch your own Card or follow the Card illustrations.

FINISHING: See General Instructions. Sew a jacket type zipper down the front.

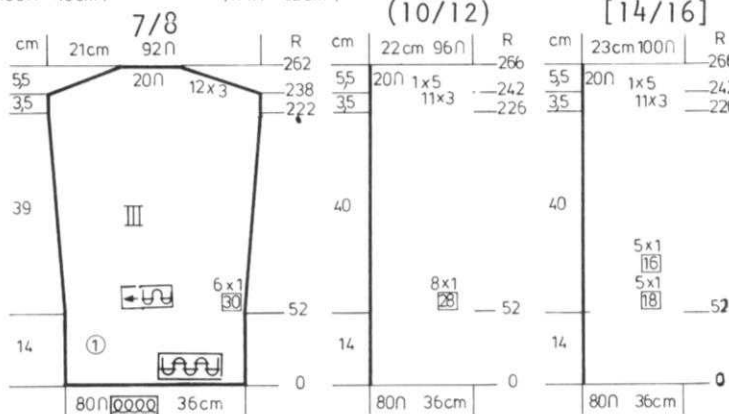

SLEEVES: III

Cast on 80 sts. with Yarn 1 for all sizes and work 52 rows K1, P1 Ribbing.

Continue in Stockinette stitch.

ON EACH SIDE, increase 1 st.

every 30th row 6x.

(every 28th row 8x,).

[every 18th row 5x, every 16th

row 5x].

After Row 238 (242) [242], ON EACH

SIDE, bind off

3 sts. 12x.

(3 sts. 11x, 5 sts. 1x).

[3 sts. 12x, 4 sts. 1x].

After Row 262 (266) [266], bind off the remaining sts.

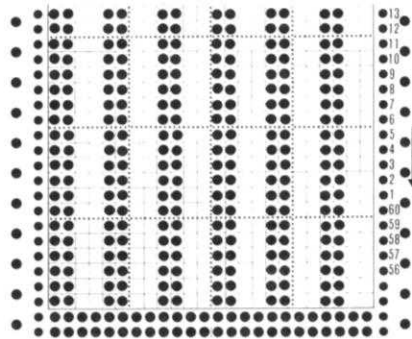

Pattern I

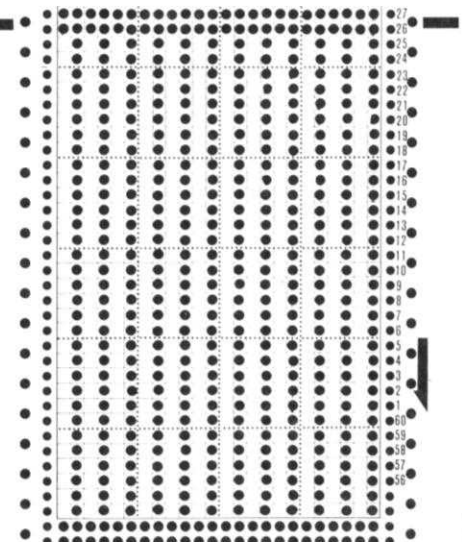

Pattern II

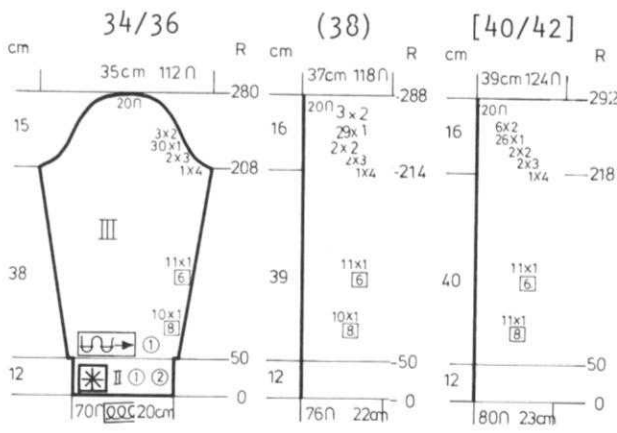

SLEEVES: III

Cast on 70 (76) [80] sts. with color 2 and work 50 rows of Pattern II. Continue with color 1 and Stockinette stitch.
 ON EACH SIDE, increase 1 st. every 8th row 10x, every 6th row 11x. (every 8th row 10x, every 6th row 11x). [every 8th row 11x, every 6th row 11x].
 Knit to Row 208 (214) [218].
 SHAPE CAP: ON EACH SIDE, bind off 4 sts. 1x, 3 sts. 2x, 1 st. 30x, 2 sts. 3x.
 (4 sts. 1x, 3 sts. 2x, 2 sts. 2x, 1 st. 29x, 2 sts. 3x).
 [4 sts. 1x, 3 sts. 2x, 2 sts. 2x, 1 st. 26x, 2 sts. 6x].
 After Row 280 (288) [292], bind off the remaining sts.

BACK: II

Cast on 160 (172) [184] sts. with color 2 and work 20 rows Stockinette stitch.
 Continue in the Norwegian Design using Pattern No. II.
 Knit to Row 50. Hang the hem. Change to Stockinette stitch and color 1.
 Knit to Row 200 (200) [204].
 SHAPE ARMHOLE but at the same time, change to Pattern 1 after Row 220 (220) [224].
 Bind off 4 sts. 1x, 3 sts. 2x, 2 sts. 1x, 1 st. 4x. (4 sts. 1x, 3 sts. 2x, 2 sts. 2x, 1 st. 4x).
 [4 sts. 1x, 3 sts. 2x, 2 sts. 3x, 1 st. 4x].
 Knit to Row 294 (298) [302].
 SHAPE SHOULDER and watch for Neck Shaping.
 FOR SHOULDER, bind off 6 sts. 5x, 9 sts. 1x, (8 sts. 5x, 3 sts. 1x), [8 sts. 5x, 5 sts. 1x].
 FOR NECK, After Row 302 (306) [310], bind off the center 20 (20) [18] sts., put the needles on the left into holding position and complete the right side first.
 *ON NECK SIDE, bind off 5 sts. 3x. (5 sts. 3x). [6 sts. 3x].
 Bring the needles on the left into working position, knit 1 row in Pattern to the left side, turn the Row Counter back to 302 (306) [310] and complete the left half. Follow the instructions from * and don't forget to complete the shoulder shaping.

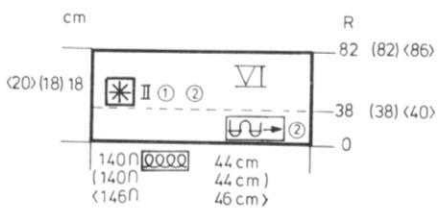
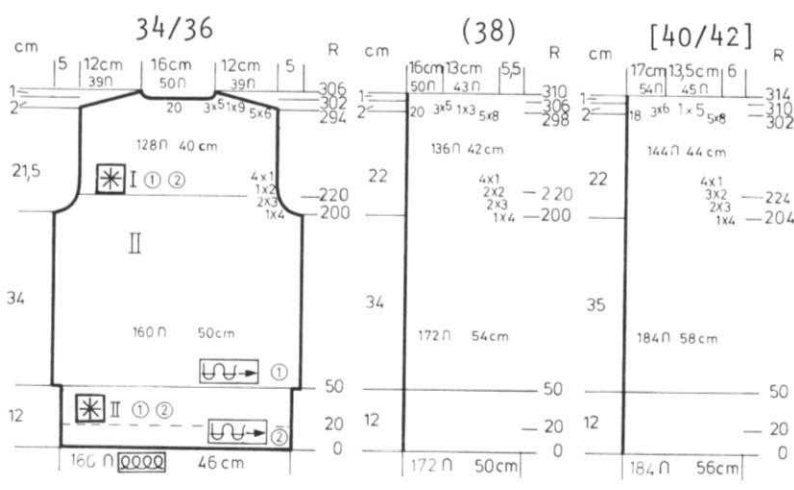

COLLAR: VI

Cast on 140 (140) [146] sts. with color 2 and work 38 (38) [40] rows Stockinette stitch. Continue in Pattern II. Knit to Row 82 (82) [86]. Bind off.

FRONT: I Make 1, reverse 1

Cast on 84 (90) [95] sts. with color 2 and work 20 rows Stockinette stitch.
 Continue with Pattern II and knit to Row 50. Hang the hem.
 Continue with color 1 and Stockinette stitch.
 Knit to Row 201 (201) [205].
 SHAPE ARMHOLE, but at the same time, change to Pattern 1 after Row 220 (220) [224].
 Bind off 4 sts. 1x, 3 sts. 2x, 2 sts. 2x, 1 st. 4x. (4 sts. 1x, 3 sts. 2x, 2 sts. 2x, 1 st. 4x). [4 sts. 1x, 3 sts. 2x, 2 sts. 3x, 1 st. 4x].
 Knit to Row 264 (264) [268].
 SHAPE NECK: Bind off 6 sts. 1x, 4 sts. 2x, 2 sts. 4x, 1 st. 5x, and SHAPE SHOULDER same as the back after Row 295. (6 sts. 1x, 4 sts. 2x, 2 sts. 5x, 1 st. 5x and SHAPE SHOULDER same as the back after Row 299). [8 sts. 1x, 4 sts. 2x, 2 sts. 5x, 1 st. 4x and SHAPE SHOULDER same as the back after Row 303].

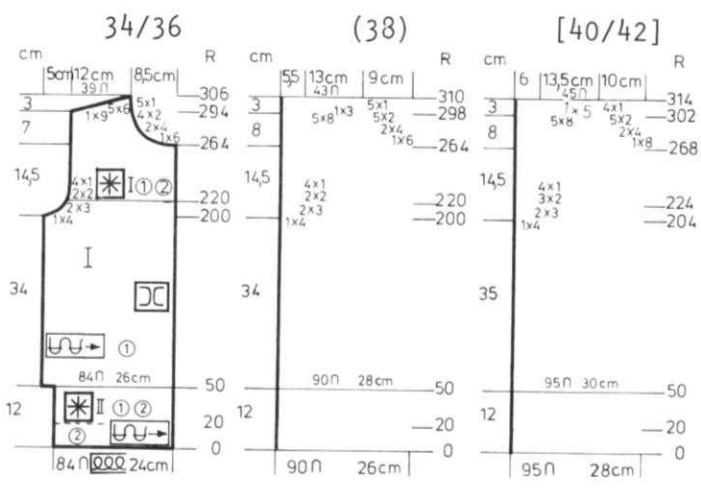

DK 437



WOMAN'S PULLOVER

SIZES: 7/8 (10) [12]
 YARN: Fortissima
 GRAMS: 350 400 450
 TENSION: 6 to 8
 GAUGE: 14 sts. 20 rows = 5 cm (2")

Stockinette stitch worn on the Knit side. Bands and Collar are K1, P1 Ribbing.

FINISHING: See General Instructions.

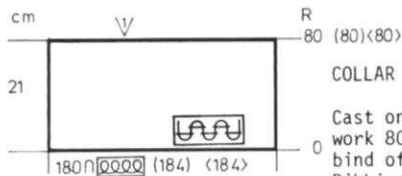
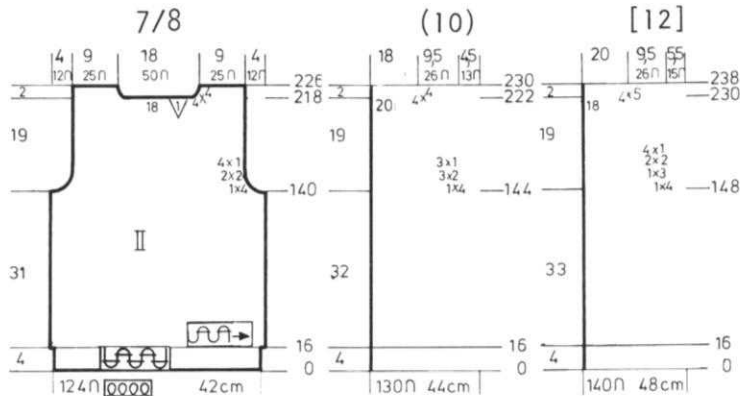

Cast on 180 (184) [184] sts. and work 80 rows K1, P1 Ribbing then bind off the crochet method for Ribbing.

BACK:

Cast on 124 (130) [140] sts. and work 16 rows K1, P1 Ribbing. Continue in Stockinette stitch. Knit to Row 140 (144) [148]. SHAPE ARMHOLE: ON EACH SIDE, bind off

4 sts. 1x, 2 sts. 2x, 1 st. 4x. (4 sts. 1x, 2 sts. 3x, 1 st. 3x). [4 sts. 1x, 3 sts. 1x, 2 sts. 2x, 1 st. 4x].

Knit to Row 218 (222) [230]. Bind off the center 18 (20) [18] sts., put the needles on the left into holding position and complete the right side first.

*ON NECK SIDE, bind off

4 sts. 4x.

(4 sts. 4x).

[5 sts. 4x].

Knit to Row 226 (230) [238] then bind off the remaining sts.

Move the Cam Box to the left side, turn the Row Counter back to 218 (222) [230] and complete the left half. Follow the instructions from *.

DK 438



WOMAN'S JACKET

SIZES: 12/14 (16/18)
 YARN: Euro Sport
 GRAMS:
 Color 1 700 750
 Color 2 150 200
 Color 3 150 200
 Color 4 200 250
 TENSION: 8 to 10
 GAUGE: 14 sts. 15 rows = 5 cm (2")

A Norwegian Design. Punch your own Card or follow the Card Illustration. Bands are Stockinette stitch.

FINISHING: See General Instructions.

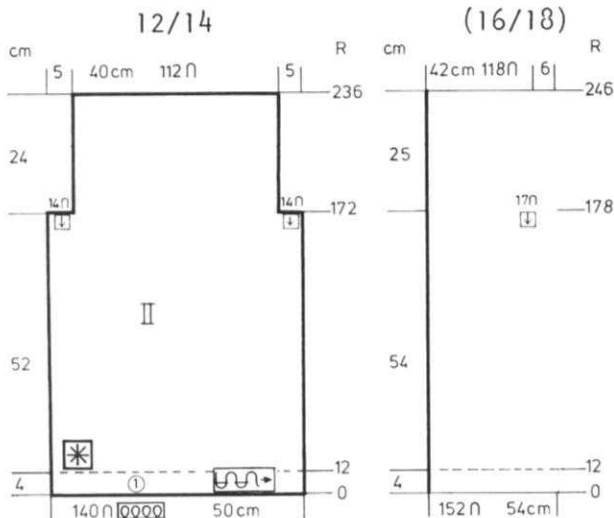

The Pattern is a REPEAT of 56 rows as follows:

- 4 rows color 1
- 5 rows color 1 + 4
- 4 rows color 1
- 3 rows color 1 + 2
- 3 rows color 1 + 3
- 3 rows color 1 + 4
- 3 rows color 1 + 3
- 3 rows color 1 + 2
- 4 rows color 1
- 5 rows color 1 + 4
- 4 rows color 1
- 3 rows color 1 + 2
- 3 rows color 1 + 3
- 3 rows color 1 + 4
- 3 rows color 1 + 3
- 3 rows color 1 + 2

REPEAT FROM THE BEGINNING.

BACK: II

Cast on 140 (152) sts. with color 1 and work 12 rows Stockinette stitch. Continue in the Norwegian Design. Knit to Row 172 (178). SHAPE ARMHOLE: ON EACH SIDE, bind off 14 (17) sts. Knit to Row 236 (246). Bind off the remaining sts.

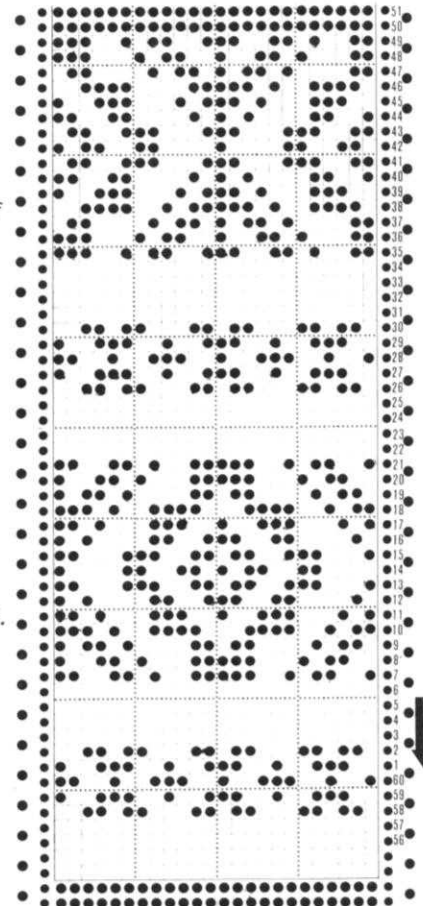

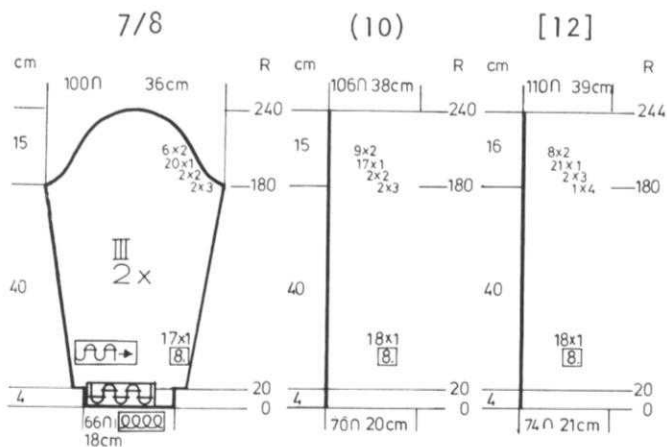

R SLEEVES: III
 Cast on 66 (70) [74] sts. and work 20 rows K1, P1 Ribbing. Continue in Stockinette stitch. ON EACH SIDE, increase 1 st. every 8th row 17x (18x) [18x]. Knit to Row 180.
 SHAPE CAP: ON EACH SIDE, bind off 3 sts. 2x, 2 sts. 2x, 1 st. 20x, 2 sts. 6x. (3 sts. 2x, 2 sts. 2x, 1st. 17x, 2 sts. 9x). [4 sts. 1x, 3 sts. 2x, 1st. 21x, 2 sts. 8x]. After Row 240 (240) [244], bind off the remaining sts.

FRONT: I

Work the front the same as the back to Row 140 (144) [148]. SHAPE ARMHOLE same as the back then knit to Row 190 (194) [200]. Put half the sts. on the left into holding position and complete the right side first.
 *ON NECK SIDE, bind off 6 sts. 1x, 4 sts. 2x, 3 sts. 2x, 1 st. 5x. (7 sts. 1x, 4 sts. 2x, 3 sts. 2x, 1 st. 5x). [7 sts. 1x, 4 sts. 2x, 3 sts. 2x, 2 sts. 1x, 1 st. 6x]. Knit to Row 226 (230) [238] then bind off the remaining sts. Move the Cam Box to the left side, turn the Row Counter back to 190 (194) [200] and complete the left half. Follow the instructions from *.

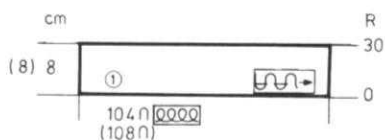
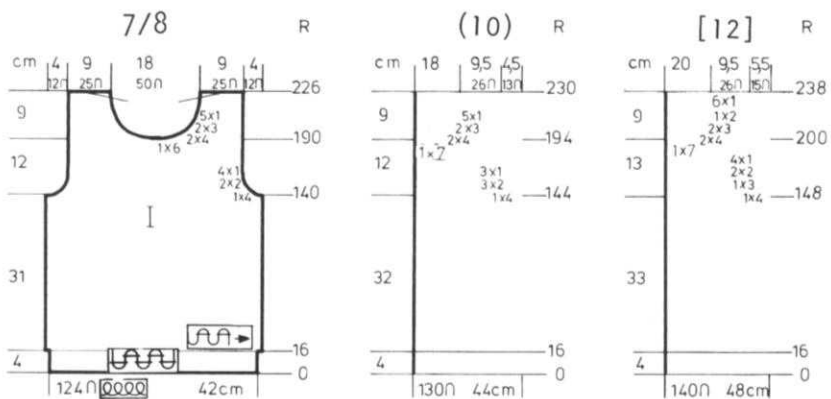

NECKBAND:

Cast on 104 (108) sts. with color 1 and work 30 rows Stockinette stitch then bind off.

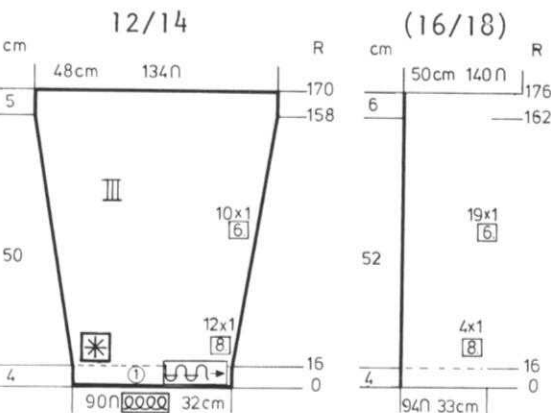
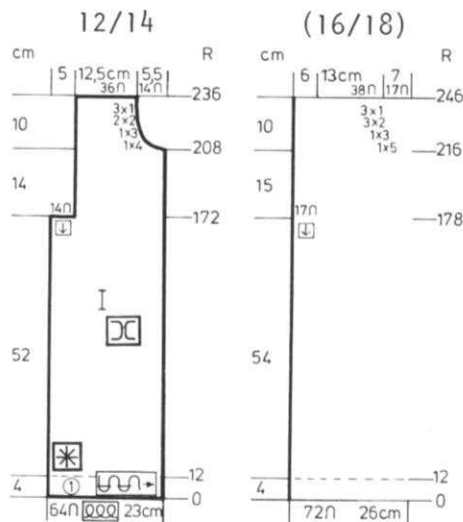

SLEEVES: III

Cast on 90 (94) sts. with color 1 and work 16 rows Stockinette stitch. Continue in the Norwegian Design. ON EACH SIDE, increase 1 st. every 8th row 12x, every 6th row 10x. (every 8th row 4x, every 6th row 19x). Knit to Row 170 (176) then bind off the remaining sts.

FRONT: I Make 1, reverse 1.

Cast on 64 (72) sts. with color 1 and work 12 rows Stockinette stitch. Continue in the Norwegian Design. Knit to Row 173 (179). Bind off 14 (17) sts. for armhole. Knit to Row 208 (216). SHAPE NECK: Bind off 4 sts. 1x, 3 sts. 1x, 2 sts. 2x, 1 st. 3x. (5 sts. 1x, 3 sts. 1x, 2 sts. 3x, 1 st. 3x). After Row 236 (246), bind off the remaining sts.

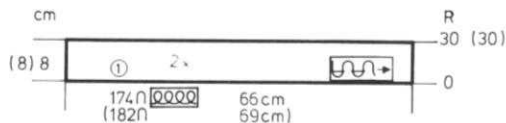

FRONT BANDS: Make 2.

Cast on 174 (182) sts. with color 1 and work 30 rows Stockinette stitch then bind off.

DK 439



WOMAN'S SKIRT with FRINGE

SIZES: 8/10 (12/14)
 YARN: Fortissima
 Color 1 500 550
 Color 2 100 100
 Color 3 100 100
 Color 4 100 100
 TENSION: 6 to 8
 GAUGE: 15 sts. 19 rows = 5 cm (2")

Stockinette stitch with a Norwegian Design. Punch your own Card or follow the Card Illustration.

FINISHING: See General Instructions. For the Fringe, wind yarn around a 10" cardboard and cut one side ONLY. Use 6 strands of yarn, fold in half and tie into every 4th stitch, alternating the colors.

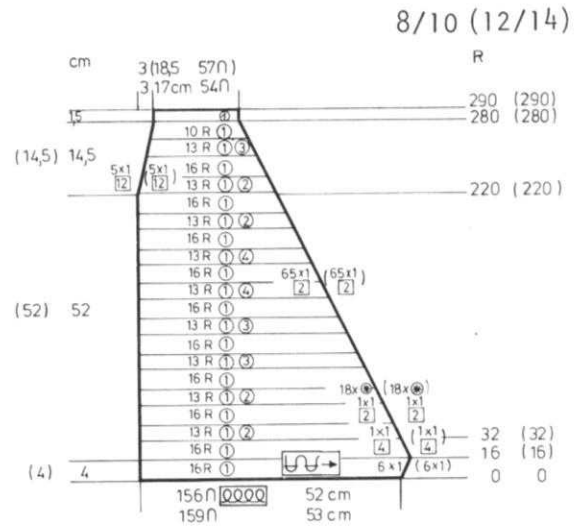
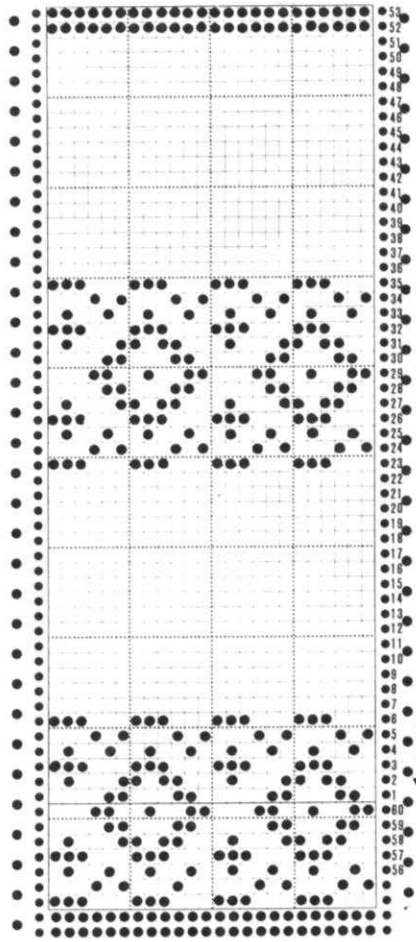

DK 440

WOMAN'S JACKET with HOOD

SIZES: 8/10 (12/14)
 YARN: Capriccio OR Micaela
 GRAMS: Capriccio 450 500
 Micaela 600 650
 TENSION: 5 to 7 for Capriccio. 4 to 6 for Micaela
 GAUGE: 12 sts. 42 rows = 5 cm (2" in Pattern.

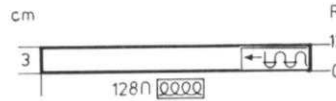

UNDER BAND FOR ZIPPER Make 2.

Cast on 128 sts. and work 12 rows Stockinette stitch then bind off. Sew this band over zipper tape on inside of jacket.

A Tuck stitch for Punch Card machines. Punch your own card. A Holding Position Design for AM 3 KNITTING machines. Use Wheel No. 6. Push in the RIGHT Retractor Button and leave it there. *Dial 1, knit 2 rows Dial 2, knit 2 rows REPEAT from *.

The Purl or the Knit side can be the right side.

FINISHING: See General Instructions. Sew Hood in Place. Stuff hem of hood with cotton batting. Work 1 row single crochet down the front edges then 1 row reverse single crochet. Sew in a jacket type zipper.

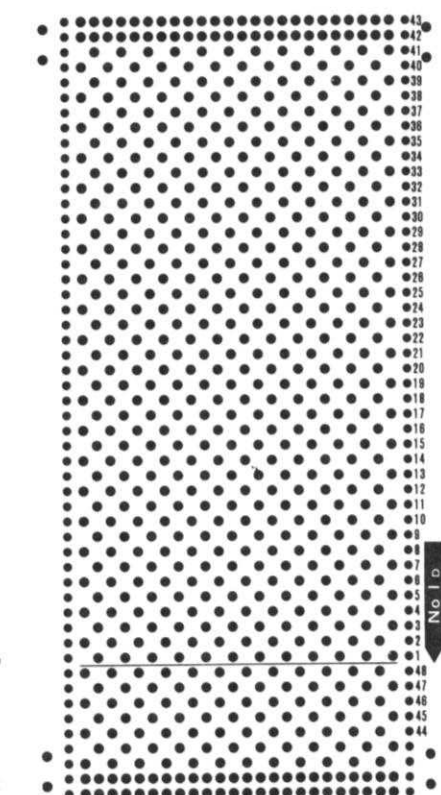
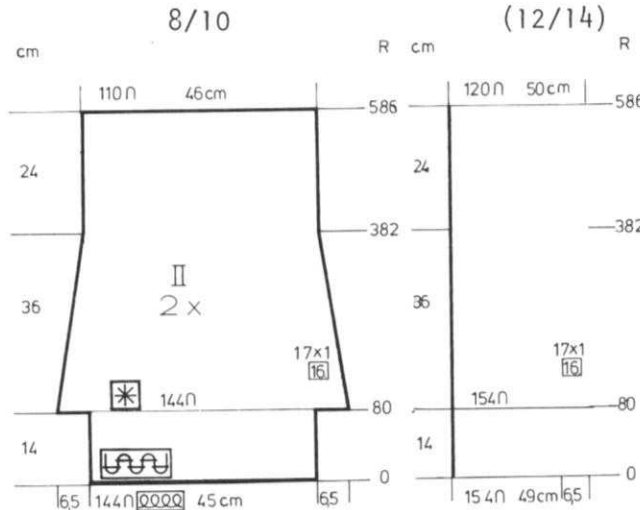

BACK: II

Cast on 144 (154) sts. Lower the tension and work 80 rows K1, P1 Ribbing. Change to garment tension and continue in Pattern. ON EACH SIDE, decrease 1 st. every 16th row 17x. Knit to Row 586, then bind off.

Make 2, reverse 2.

Cast on 156 (159) sts. with color 1 and work Stockinette stitch with lower tension.

ON THE RIGHT (left for reverse sections) increase 1 st. every 2nd row 6x.

After Row 16, continue with garment tension. Follow the Chart for the color sequence and Norwegian Design and ON THE RIGHT (left) *decrease 1 st. every 4th row 1x, every 2nd row 1x, and REPEAT these decreases from * 18x more, then decrease 1 st. every 2nd row 65x.

AT THE SAME TIME, after Row 220, on the LEFT (right) decrease 1 st. every 12th row 5x.

Following the Chart, knit to Row 290, then bind off the remaining sts.

Work another section the same, then 2 more with reverse shaping.

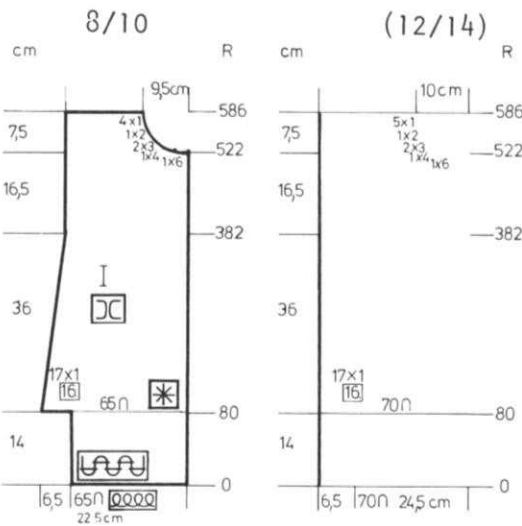

FRONT: I Make 1, reverse 1.

Cast on 65 (70) sts. Lower the tension and work 80 rows K1, P1 Ribbing. Change to garment tension and continue in Pattern. ON THE LEFT (right for 2nd section) decrease 1 st. every 16th row 17x. Knit to Row 522. SHAPE NECK: Bind off 6 sts. 1x, 4 sts. 1x, 3 sts. 2x, 2 sts. 1x, 1 st. 4x. (6 sts. 1x, 4 sts. 1x, 3 sts. 2x, 2 sts. 1x, 1 st. 5x). After Row 586, bind off the remaining sts.

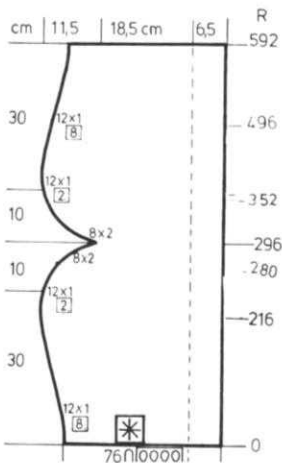

HOOD:

Cast on 76 sts. and work in Pattern. ON THE LEFT side, increase 1 st. every 8th row 12x. After Row 216, ON THE LEFT side, decrease 1 st. every 2nd row 12x then after Row 280, decrease 2 sts. every 2nd row 8x. After Row 296, ON THE LEFT, increase 2 sts. every 2nd row 8x. After Row 352, ON THE LEFT, increase 1 st. every 2nd row 12x. After Row 496, ON THE LEFT, decrease 1 st. every 8th row 12x. After Row 592, bind off.

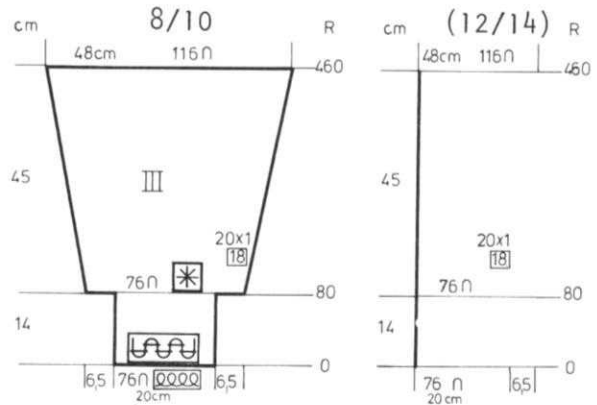

SLEEVES: III

Cast on 76 sts. Lower the tension and work 80 rows K1., P1 Ribbing. Change to garment tension and continue in Pattern. ON EACH SIDE, increase 1 st. every 18th row 20x. After Row 460, bind off

HP 441



MAN'S JACKET

SIZES: 36 (38/40) [42]
 YARN: Binia
 GRAMS: 700 800 900
 TENSION: 9 to 10
 GAUGE: 11 sts. 21 rows = 5 cm (2")

Punch Card machines, set for Tuck. Punch your own Card. AM 3 KNITTING machine owners, use Wheel No. 2.

*Dial 1, knit 3 rows, push in left Retractor Button, knit 1 row. Release Button.
 Dial 4, knit 3 rows, push in left Retractor Button, knit 1 row. Release Button.
 REPEAT from *.

FINISHING: See General Instructions.

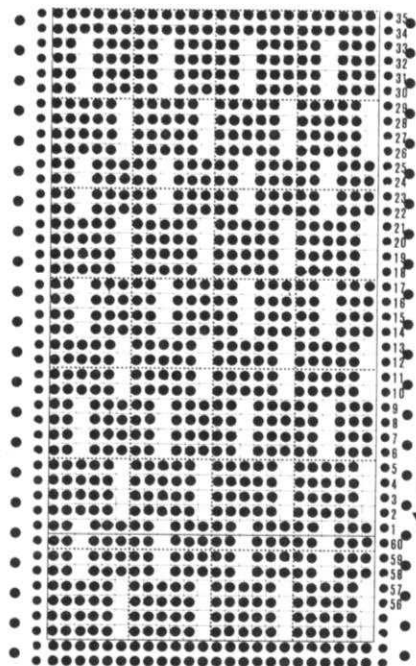

Continued

HP 441

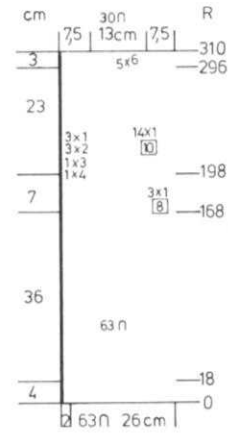
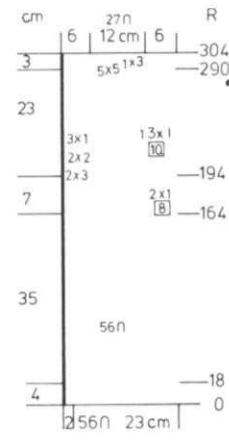
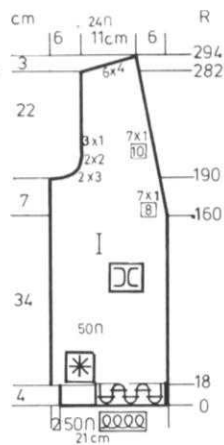

FRONT: I Make 1, reverse 1.

Cast on 50 (56) [63] sts. and work 18 rows K1, P1 Ribbing. Continue in Pattern. Knit to Row 160 (164) [168]. ON FRONT EDGE, decrease 1 st. every 8th row 7x, every 10th row 7x, (every 8th row 2x, every 10th row 13x), [every 8th row 3x, every 10th row 14x], AND AT THE SAME TIME, after Row 191 (195) [199], SHAPE ARMHOLE: Bind off 3 sts. 2x, 2 sts. 2x, 1 st. 3x. (3 sts. 2x, 2 sts. 2x, 1 st. 3x). [4 sts. 1x, 3 sts. 1x, 2 sts. 3x, 1 st. 3x]. After Row 283 (291) [297], SHAPE SHOULDER same as the back.

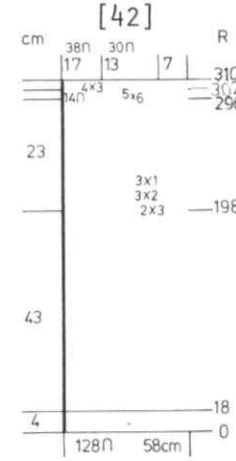
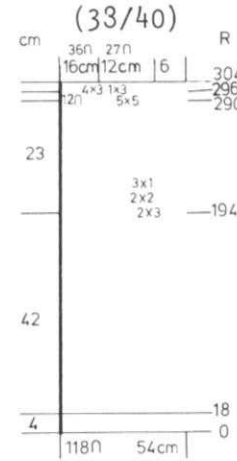
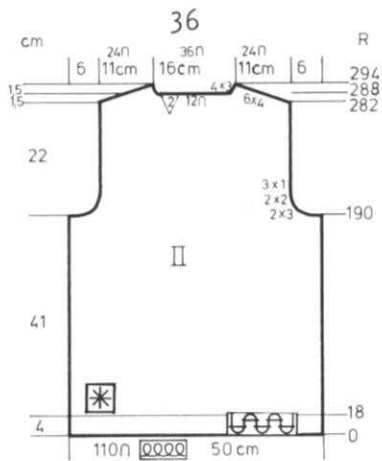

BACK: II
Cast on 110 (118) [128] sts. and work 18 Rows K1, P1 Ribbing. Continue in Pattern. Knit to Row 190 (194) [198]. SHAPE ARMHOLE: ON EACH SIDE, bind off 3 sts. 2x, 2 sts. 2x, 1 st. 3x. (3 sts. 2x, 2 sts. 2x, 1 st. 3x). [3 sts. 2x, 2 sts. 3x, 1 st. 3x]. Knit to Row 282 (290) [296]. SHAPE SHOULDER and watch for NECK SHAPING: FOR SHOULDER, bind off 4 sts. 6x, (5 sts. 5x). [6 sts. 5x]. FOR NECK, after Row 288 (296) [302], bind off the center 12 (12) [14] sts., put the needles on the left into holding position and complete the right side first. *ON NECK SIDE, bind off 3 sts. 4x for all sizes. Bring the needles on the left into working position, knit 1 row in Pattern to the left side, turn the Row Counter back to 288 (296) [302] and complete the left half. Follow the instructions from *.

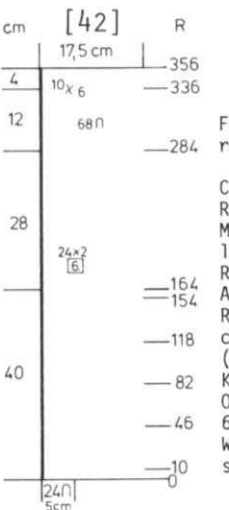
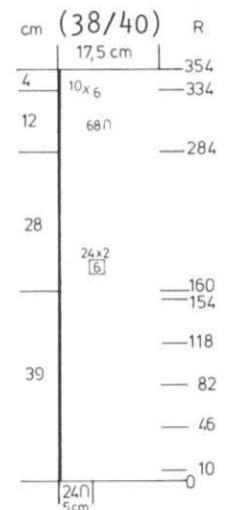
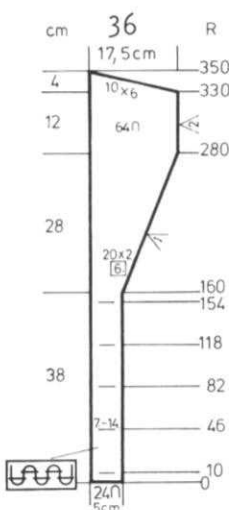

FRONT BAND & COLLAR: Make 1, reverse 1 and omit Buttonholes. Cast on 24 sts. and work K1, P1 Ribbing. MAKE BUTTONHOLES over needles 7 to 14 counting from the left after the Rows shown on the Chart. After Row 160 (160) [164], on the RIGHT (left for 2nd section), increase 2 sts. every 6th row 20x (24x) [24x]. Knit to Row 330 (334) [336]. ON THE RIGHT (left), bind off 6 sts. 10x. Work the 2nd section with reverse shaping but omit the buttonholes.

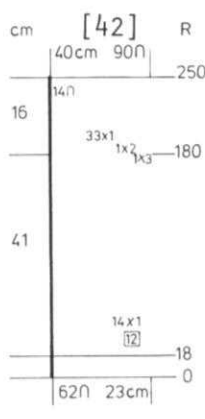
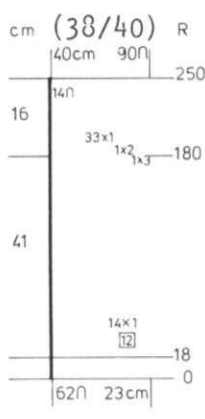
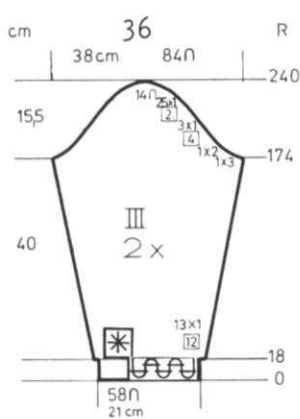

SLEEVES: III
Cast on 58 (62) [62] sts. and work 18 rows K1, P1 Ribbing. Continue in Pattern. ON EACH SIDE, increase 1 st. every 12th row 13x (14x) [14x]. After Row 174 (180) [180], SHAPE CAP: ON EACH SIDE, bind off 3 sts. 1x, 2 sts. 1x, 1 st. every 4th row 3x, 1 st. every 2nd row 25x. (3 sts. 1x, 2 sts. 1x, 1 st. 33x) [3 sts. 1x, 2 sts. 1x, 1 st. 33x]. After Row 240 (250) [250], bind off the remaining sts.

KK 442



CHILD'S OVERALLS

SIZES: 5/6 (7/8) [9/10]
 YARN: Euro Sport
 GRAMS:
 Color 1 250 300 350
 Color 2 50 100 100
 Color 3 50 100 100
 TENSION: 7 to 9
 GAUGE: 13 sts. 19 rows = 5 cm (2")

A Norwegian Design. Punch your own Card or follow the Punch Card Illustration.

FINISHING: See General Instructions, Work 1 row single crochet then 1 row reverse single crochet around neckline and armholes. Sew in zipper.

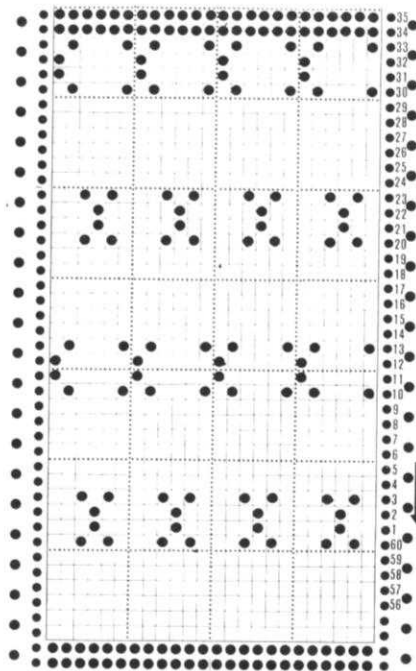

The Pattern is a REPEAT of 10 rows as follows:

- 1 row Color 1 + 2
- 2 rows Color 1 + 3
- 1 row Color 1 + 2
- 6 rows Color 1

Make 1, reverse 1.

Cast on 88 (92) [98] sts. with color 1 and work 20 rows Stockinette stitch. Hang the hem then continue in Pattern.

Knit to Row 70 (78) [84]. ON EACH SIDE, increase 1 st. every 8th row 6x, every 6th row 6x.

After Row 154 (162) [168], ON EACH SIDE, bind off 2 sts. 1x, 1 st. 7x.

(2 sts. 1x, 1 st. 7x).

[2 sts. 1x, 1 st. 8x].

Knit to Row 278 (290) [304].

Divide in the center, put the needles on the left into holding position and complete the right side first.

*SHAPE NECK and watch for front (back) shaping.

ON NECK SIDE, bind off 4 sts. 1x, 3 sts. 1x, 2 sts. 3x, 1 st. 2x, and bind off 20 sts. after Row 286.

(4 sts. 1x, 3 sts. 1x, 2 sts. 3x, 1 st. 3x, and bind off 21 sts. after Row 298)

[4 sts. 1x, 3 sts. 2x, 2 sts. 2x, 1 st. 3x and bind off 22 sts. after Row 312.

Knit to Row 336 (348) [364], then bind off the remaining sts.

Bring the needles on the left into working position, knit 1 row in Pattern to the left side, turn the Row Counter back to 278 (290) [304] and complete the left side. Follow the instruction from * for NECK SHAPING, but bind off the 20 (21) [22] sts. after Row 313 (325) [343].

Knit to Row 336 (348) [364] then bind off the remaining sts.

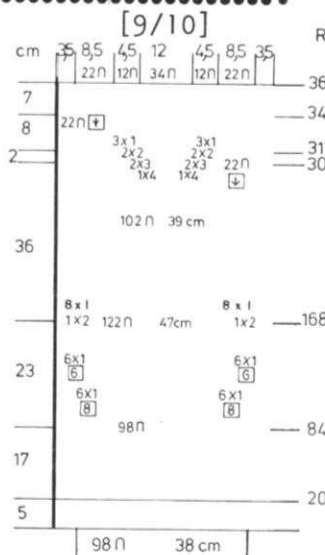
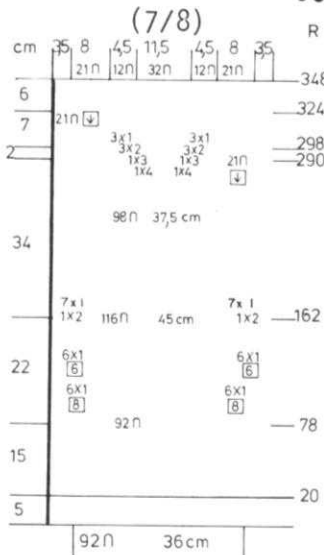
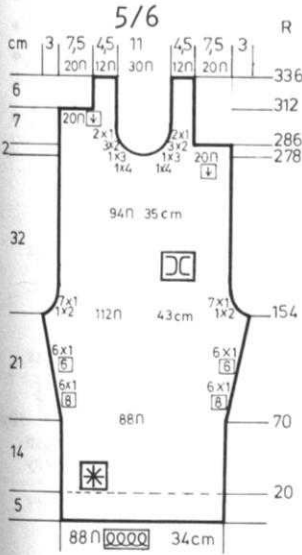

KK 443



GIRL'S JACKET

SIZES: 5/6 (7/8) [9/10]
 YARN: Vienna = Color 1 (for knitting).
 Summertime = Color 2 for weaving.
 GRAMS:
 Color 1 250 300 350
 Color 2 250 300 350
 TENSION: 9 or 10
 GAUGE: 12 sts. 17 rows = 5 cm

A Weaving Design. Punch your own Card or follow the Punch Card illustration. Worn on the Purl side.

FINISHING: See General Instructions. Sew back seam of hood then sew to Jacket neckline. Sew band to front edges of hood.

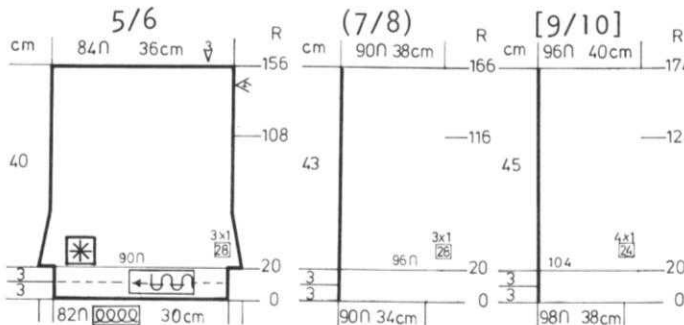

BACK: II

With contrast waste yarn, cast on 90 (96) [104] sts. and work Stockinette stitch. Knit 8 to 10 rows, then change to Garment yarn and Put Counter at 20. Continue in Pattern.

ON EACH SIDE, decrease 1 st. every 28th row 3x (3x) [every 24th row 4x].

Knit to Row 108 (116) [124]. Mark EACH SIDE, with a bit of waste yarn (for sleeve) then knit to Row 156 (166) [174]. Bind off.

FOR WAISTBAND - Hang the sts. held on waste yarn onto the machine, decreasing to 82 (90) [98] sts. Remove the waste yarn and work 20 rows Stockinette stitch then bind off.



KK 443

FRONT: I Make 1, reverse 1.

With contrast waste yarn, cast on 44 (50) [56] sts. and work Stockinette stitch. Knit 8 to 10 rows, change to garment yarn and put Counter at 20. Continue in Pattern. ON SIDE EDGE, decrease 1 st. every 14th row 6x (6x) [7x]. Knit to Row 108 (116) [124] then mark side edge as you did for back.

Knit to Row 131 (141) [149].
SHAPE NECK: Bind off 3 sts 2x, 2 sts. 2x, 1 st. 2x. (3 sts. 2x, 2 sts. 3x, 1 st. 3x). [3 sts. 2x, 2 sts. 3x, 1 st. 4x]. After Row 156 (166) [174], bind off the remaining sts.
Hang the open sts. held on waste yarn onto the machine, decreasing to 38 (43) [48] sts. Remove the waste yarn and knit 20 rows Stockinette stitch. Bind off.

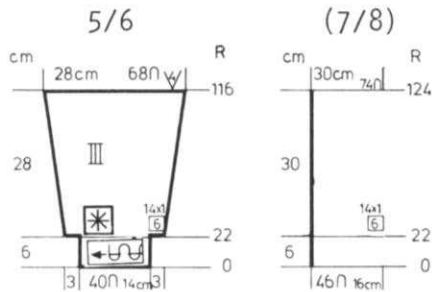
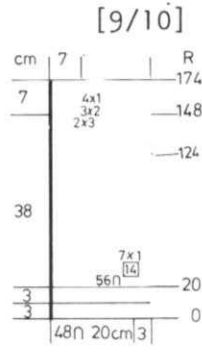
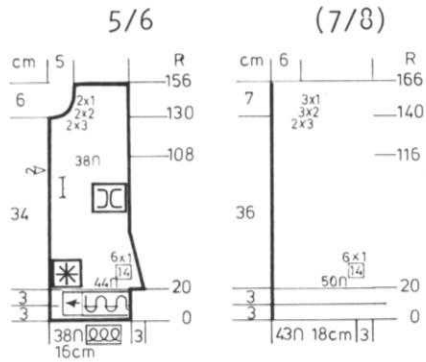

SLEEVES: III

Cast on 40 (46) [50] sts. and work Stockinette stitch with a lower Tension to Row 22. Continue in Pattern. ON EACH SIDE, increase 1 st. every 6th row 14x. Knit to Row 116 (124) [130], then bind off the remaining sts.

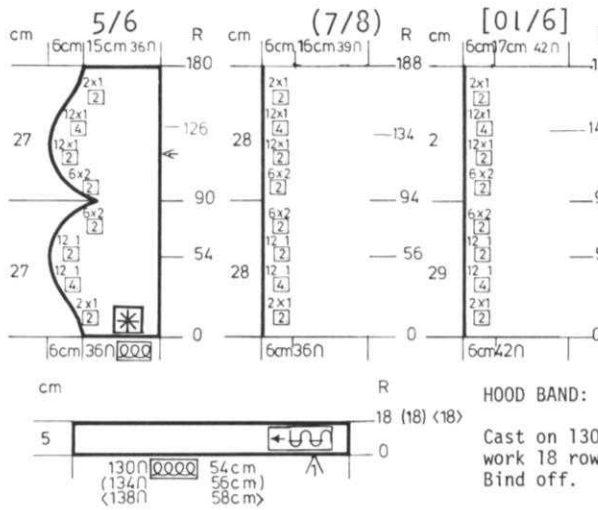

HOOD:

Cast on 36 (36) [42] sts. and work in Pattern, making all the shapings on the LEFT SIDE. Increase 1 st. every 2nd row 2x, every 4th row 12x. After Row 54 (56) [56], decrease 1 st. every 2nd row 12x, then 2 sts. 6x. After Row 90 (94) [98], increase 2 sts. every 2nd row 6x, then 1 st. 12x. After Row 126 (134) [142], decrease 1 st. every 4th row 12x, then every 2nd row 2x. After Row 180 (188) [196], bind off the remaining sts.

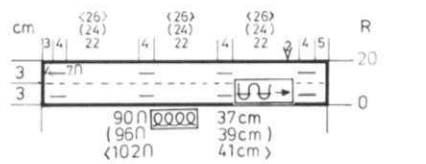

FRONT BANDS: Make 2 but omit the buttonholes in 2nd section. Cast on 90 (96) [102] sts. and work Stockinette stitch. After Row 5, make BUTTONHOLES over needles 4 to 7, 30 to 33, 56 to 59, 92 to 85. (4 to 7, 32 to 35, 60 to 63, 88 to 90). [4 to 7, 34 to 37, 64 to 67, 94 to 97]. After Row 15, make BUTTONHOLES over same needles as you did before. Knit to Row 20 then bind off.

HOOD BAND:

Cast on 130 (134 [138]) sts. and work 18 rows Stockinette stitch. Bind off.

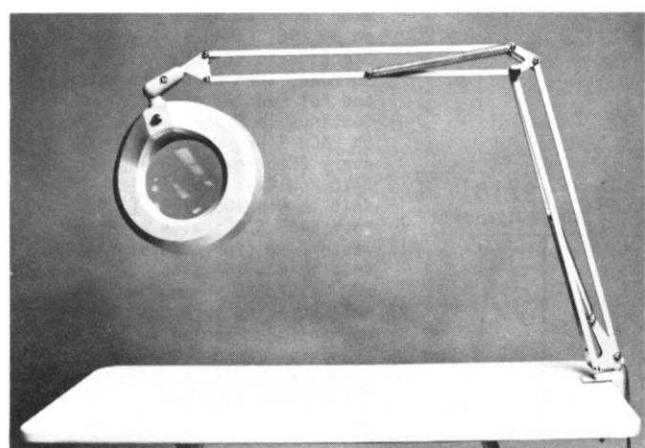

knitting magnifier lamp

A perfect gift item for any knitter. It has a large (5") magnifying lens and a cool fluorescent tube light. It stays in any position and is wonderful for general illumination for you to work under when joining seams, etc. Color: light grey.

Price: \$79.50
(California residents add Sales Tax)
Shipping Costs: \$3.00

KK 444



CHILD'S OVERALLS

SIZES: 5/6 (7/8) [9/10]
YARN: Euro Sport
GRAMS:
 Color 1 250 300 350
 Color 2 50 100 100
 Color 3 50 100 100
TENSION: 7 to 9
GAUGE: 13 sts. 19 rows = 5 cm (2")

A Norwegian Design. Punch your own Card or follow the Punch Card Illustration.

FINISHING: See General Instructions. Work 1 row single crochet then 1 row reverse single crochet around neckline and armholes. Sew in zipper.

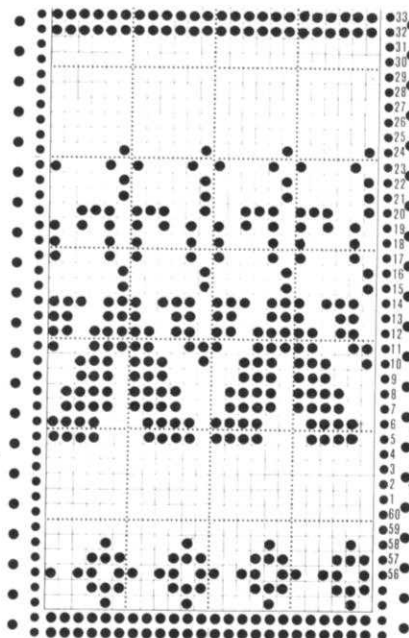

The Pattern is a REPEAT of 38 rows as follows.

- 5 rows color 1 + 3
- 6 rows color 1
- 20 rows color 1 + 2
- 7 rows color 1
- REPEAT from the beginning.

Make 1, reverse 1.

Cast on 88 (92) [98] sts. with color 1 and work 20 rows Stockinette stitch. Hang the hem then continue in Pattern.

Knit to Row 70 (78) [84]. ON EACH SIDE, increase 1 st. every 8th row 6x, every 6th row 6x.

After Row 154 (162) [168], ON EACH SIDE, bind off 2 sts. 1x, 1 st. 7x.

(2 sts. 1x, 1 st. 7x). [2 sts. 1x, 1 st. 8x].

Knit to Row 278 (290) [304]. Divide in the center, put the needles on the left into holding position and complete the right side first.

*SHAPE NECK and watch for front (back) shaping.

ON NECK SIDE, bind off 4 sts. 1x, 3 sts. 1x, 2 sts. 3x, 1 st. 2x, and bind off 20 sts. after Row 286.

(4 sts. 1x, 3 sts. 1x, 2 sts. 3x, 1 st. 3x and bind off 21 sts. after Row 298).

[4 sts. 1x, 3 sts. 2x, 2 sts. 2x, 1 st. 3x, and bind off 22 sts. after Row 312].

Knit to Row 336 (348) [364], then bind off the remaining sts. Bring the needles on the left into working position, knit 1 row in Pattern to the left side, turn the Row Counter back to 278 (290) [304] and complete the left side. Follow the instructions from * for NECK SHAPING but bind off the 20 (21) [22] sts. after Row 313 (325) [343]. Knit to Row 336 (348) [364] then bind off the remaining sts.

5/6

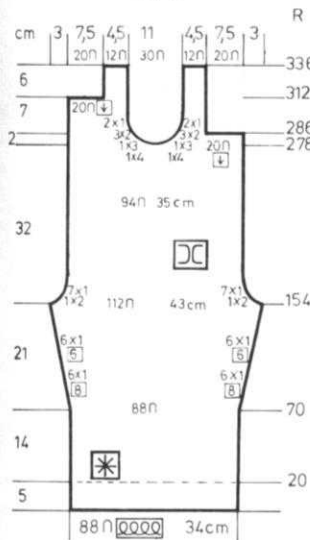

(7/8)

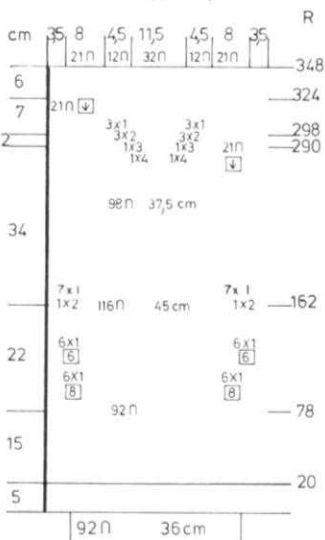

[9/10]

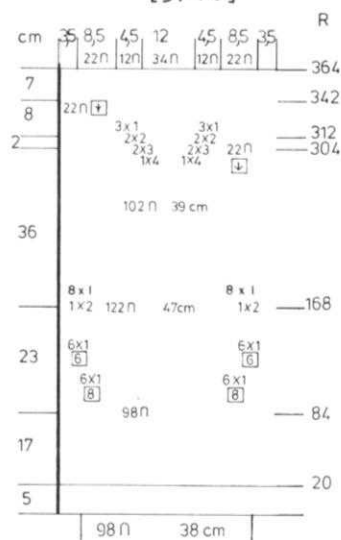

2 Bügeltücher
 in 2 Größen
 sortiert

aus
 Spezial-Faservlies
 saugfähig

...läßt Ihr Bügeleisen leicht gleiten.

NEW! Pressing Cloths

New Miracle fibre pressing cloths... absolutely perfect for knits, even for the normally hard to press yarns, especially tight twisted orlons and acrylics...

These marvelous pressing cloths are available for the first time in America... and KNITTING has them exclusively... There are two cloths to each package and the price per package is \$2.75... We are introducing them at a Special Price of \$5.00 for two packets (4 cloths) plus Shipping costs 39¢. California residents please add Sales Tax.

ORDER DIRECT FROM:
 KNITTING - 1128 Crenshaw Blvd., Los Angeles, Calif. 90019

DK 445

WOMAN'S PULLOVER with HOOD

SIZES: 12/14 (16/18)
 YARN: Vienna
 GRAMS:
 Color 1 500 550
 Color 2 200 200
 Color 3 200 200
 Color 4 100 100
 TENSION: 4 to 6
 GAUGE: 15 sts. 25 rows = 5 cm (2")



A Norwegian Design. Punch your own Card or follow the Punch Card Illustration.

FINISHING: See General Instructions.
 Sew back seam of Hood then sew to Neckline of Pullover. Make hem at front edge of Hood.

BACK: II

Cast on 148 (162) sts. with color 2 and work Stockinette stitch. With Tension 3, knit 24 rows. With Tension 8, knit 1 row. With Tension 3, knit 25 rows. Hang the hem and put Row Counter to 26. Continue with Tension 5. After Row 28, begin the Norwegian Design with Pattern I. Knit in Pattern to Row 72. Continue in Stockinette stitch with color 1. At Row 190, mark the underarm ON EACH SIDE, with a bit of contrast yarn. Knit to Row 300. SHAPE NECK: Bind off the center 20 (24) sts., put the needles on the left into holding position and complete the right side first. *ON NECK SIDE, bind off 5 sts. 1x, 4 sts. 1x, 2 sts. 3x. (7 sts. 1x, 2 sts. 3x, 1 st. 2x). After Row 312, bind off the remaining sts. Move the Cam Box to the left side, turn the Row Counter back to 300 and complete the left half. Follow the instructions from *.

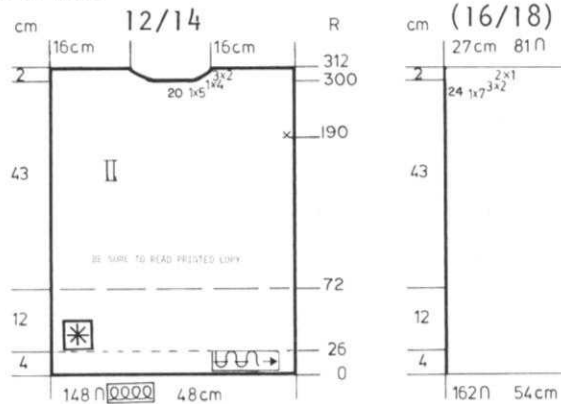
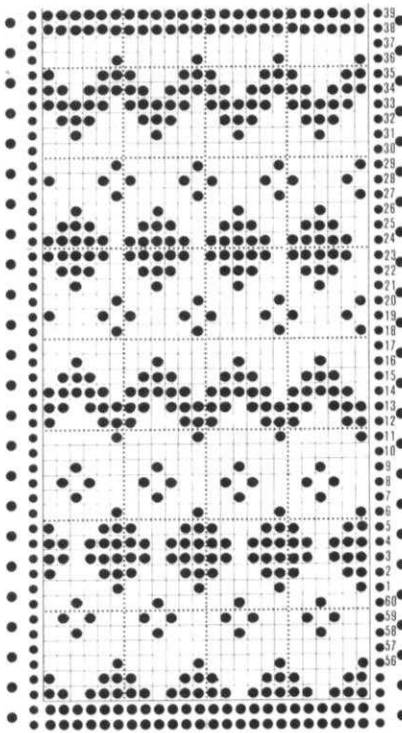

PATTERN I

- 3 rows Colors 3 + 2
- 1 row Color 2
- 3 rows Colors 3 + 4
- 6 rows Colors 3 + 2
- 3 rows Colors 3 + 4
- 1 row Color 3
- 6 rows Colors 3 + 2
- 1 row Color 3
- 3 rows Colors 3 + 2
- 6 rows Colors 3 + 4
- 3 rows Colors 3 + 2
- 1 row Color 3
- 3 rows Colors 3 + 2
- 3 rows Colors 1 + 2
- 1 row Color 2

SLEEVES: III

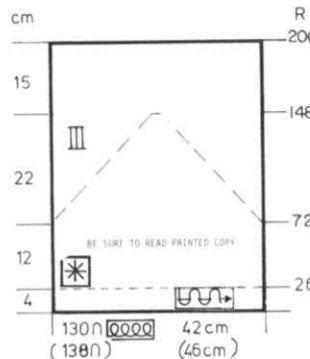

Cast on 130 (138) sts. with color 2 and work Stockinette stitch. With Tension 3, knit 24 rows. With Tension 8, knit 1 row. With Tension 3, knit 25 rows. Hang the hem and put Counter at 26. Continue with Tension 5. After Row 28, begin the Norwegian Design with Pattern I, changing to Pattern II after Row 72, BUT AT THE SAME TIME, while working Pattern II, ON EACH SIDE, ON EVERY 8TH ROW, omit 1 pattern as you did on the front to Row 148. Continue in Stockinette stitch with color 1. Knit to Row 200. Bind off.

DK 446

WOMAN'S PANTS & PULLOVER

SIZES: 7/8 (10/12)
 YARN: Allegro & Nicole(5)
 GRAMS:
 Color 1 700 750
 Color 2 50 50
 Color 3 50 50
 Color 4 100 100
 Color 5 50 50 (Nicole)
 TENSION: 6 to 8
 GAUGE: 14 sts. 16 rows = 5 cm (2")



Stockinette stitch with a Norwegian Design. Punch your own Cards or follow the Punch Card Illustration. Bands are Stockinette stitch.

FINISHING: See General Instructions.

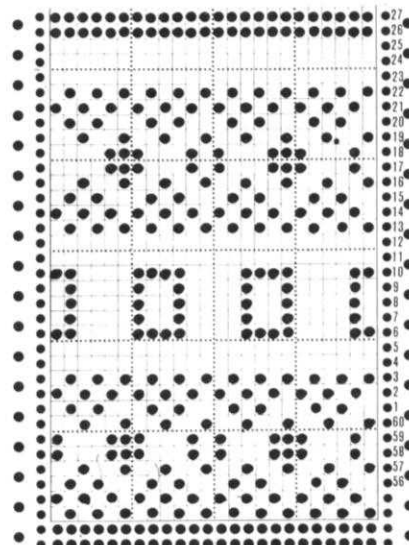

PATTERN I

- 2 rows color 1
- 2 rows colors 1 + 3
- 2 rows colors 1 + 4
- 2 rows colors 1 + 3
- 2 rows colors 1 + 2
- 2 rows color 1
- 5 rows colors 1 + 4
- 2 rows color 1
- 2 rows colors 1 + 2
- 2 rows colors 1 + 3
- 2 rows colors 1 + 4
- 2 rows colors 1 + 3
- 2 rows colors 1 + 2
- 3 rows color 1

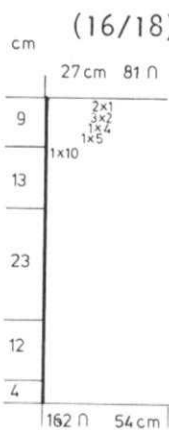
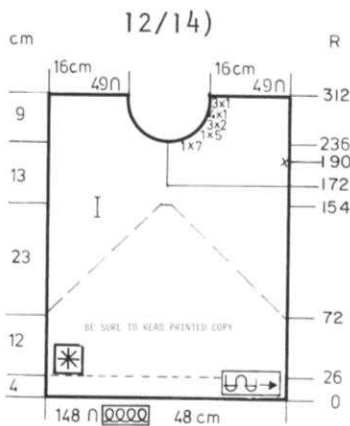
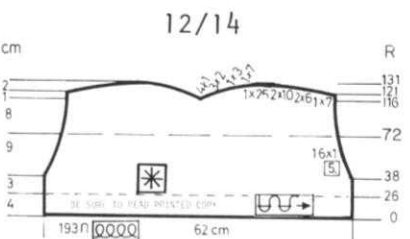
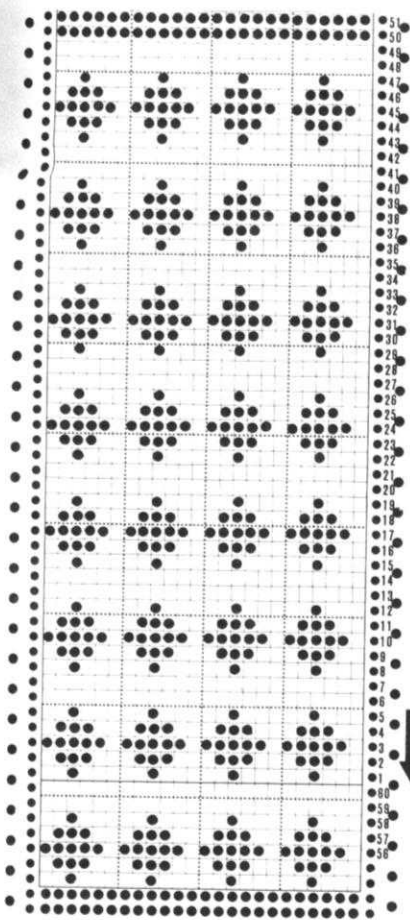

PATTERN II
 * 5 rows Colors 1 + 3
 2 rows Color 1
 REPEAT from *

HOOD:

Cast on 193 (197) sts. with color 2 and work Stockinette stitch. With Tension 3, knit 24 rows. With Tension 8, knit 1 row. With Tension 3, knit 25 rows. Hang the hem and put the Row Counter to 26. Continue with Tension 5. After Row 28, continue in the Norwegian Design with Pattern I. Knit to Row 38. ON EACH SIDE, decrease 1 st. every 5th row 16x, and AT THE SAME TIME, after Row 72, continue in Stockinette stitch with color 1. Knit to Row 116. ON EACH SIDE, bind off 7 sts. 1x, 6 sts. 2x, and AFTER ROW 121, divide in the center, put the needles on the left into holding position and complete the right half. *Work the bind-offs from the center as shown ABOVE Row 121 and AT THE SAME TIME, complete the right side bind-offs of 10 sts. 2x, 25 sts. 1x. Move the Cam Box to the left side, turn the Row Counter back to 121 and complete the left half. Follow the instructions from *.

FRONT: I

Work the front the same as the back to Row 72, then continue with Pattern II AND AT THE SAME TIME, ON EVERY 8th ROW, ON EACH SIDE, push the needles for ONE COMPLETE DIAMOND PATTERN back into working position so that you will knit 1 less diamond pattern on each side (See Picture). Knit to Row 154. Continue in Stockinette stitch with color 1. Knit to Row 172. Divide in the center, put the needles on the left into holding position and complete the right side first. *Knit to Row 190. Mark each side for underarm as you did for the back. Knit to Row 236. ON NECK SIDE, bind off 7 sts. 1x, 5 sts. 1x, 2 sts. 3x, 1 st. 4x, 1 st. 3x. (10 sts. 1x, 5 sts. 1x, 4 sts. 1x, 2 sts. 3x, 1 st. 2x). After Row 312, bind off the remaining* sts. Move the Cam Box to the left side, turn the Row Counter back to 172 and complete the left half. Follow the instructions from *.

FRONT FACINGS:

Pick up the sts. along front opening and work 26 rows stockinette stitch, changing the tensions as you did on the other sections. Work the other side of opening the same.

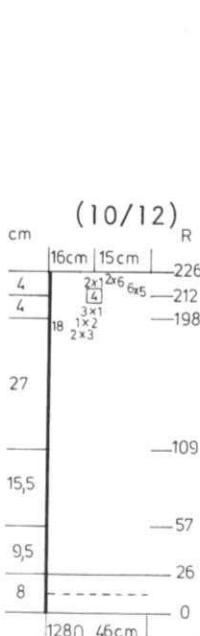
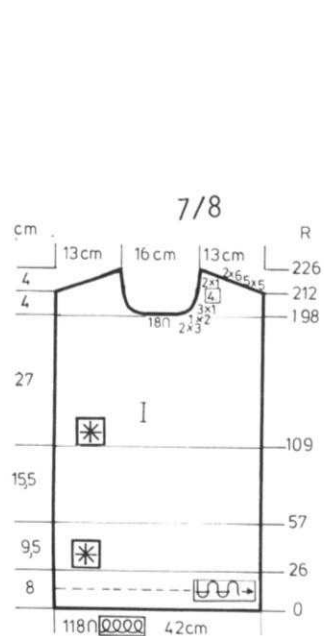

FRONT: I

Work the front the same as the back to Row 198. SHAPE NECK: Bind off the center 18 sts., put the needles on the left into holding position and complete the right side first. *ON NECK SIDE for both sizes, bind off (when Pattern is completed, continue in Stockinette stitch with color 1) 3 sts. 2x, 2 sts. 1x, 1 st. 3x, then every 4th row 1 st. 2x AND SHAPE SHOULDER same as the back after Row 212. Move the Cam Box to the left side, turn the Row Counter back to 198 and complete the left half. Follow the instructions from *.

COLLAR:

Close 1 shoulder seam first, Then with right side facing you, pick up 129 sts. around the neckline (approximately 54 across the back and 75 across the front. Lower the tension 1 number and knit 4 rows. Set the needles into Mock Rib (or K1, P1 Ribbing). Knit 30 rows, knit 1 row Tension 10, return to tension you used for first half and knit 30 rows. Bring all the needles into working position and knit 4 rows. Remove the sts. onto waste yarn. Fold in half and sew down to the inside.



DK 446

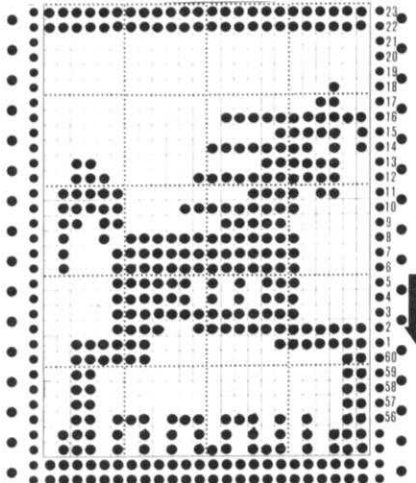

PATTERN II 25 rows colors 1 + 5
3 rows color 1

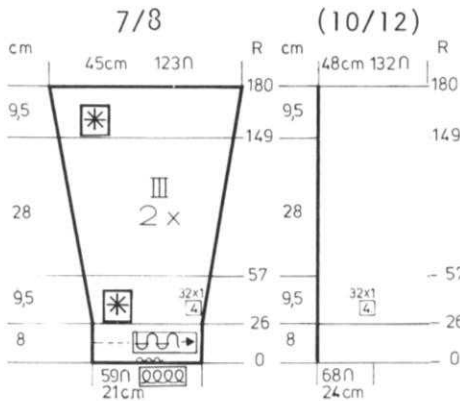

SLEEVES: III

Bring 59 (68) needles into working position then set into Mock Rib Pattern (or work K1, P1 Ribbing over all the needles for 26 rows. Turn Tension Down and work Mock Rib to Row 52. Hang the hem and continue over all the needles as you did on back & front. Put Row Counter to 26. Work the Norwegian Pattern No I AND AT THE SAME TIME, increase 1 st. every 4th row 32x changing to Stockinette stitch with color 1 when Pattern is completed. After Row 150 (Set Pattern at Row 149) work the Norwegian Pattern No I. After Row 180, bind off.

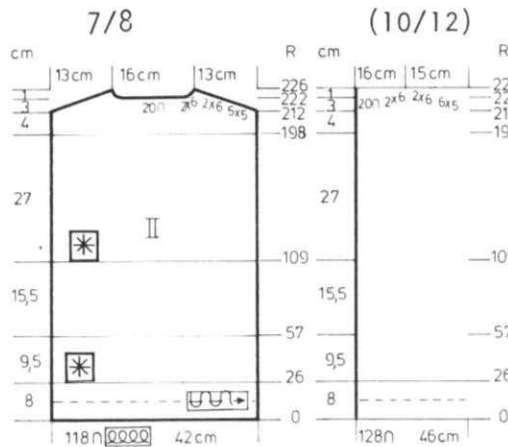

PULLOVER BACK:

Bring 118 (128) needles into working position then set into MOCK RIB with every 3rd needle out of work. (If you own a Ribber, you can work K1, P1 Ribbing over all the needles for 26 rows). Cast on over the remaining needles in work with color 1. Turn Tension down 1 number and knit 52 rows, then hang the hem. Turn to garment tension, bring empty needles into work and continue over all the needles. Put the Row Counter back to 26 and work the Norwegian Design using Pattern I to Row 57. Continue in Stockinette stitch with color 1 to Row 110 (set needles for Pattern I after Row 109). Work the Norwegian design Pattern I, then Pattern II, following by Pattern I again. When Pattern is completed, continue in Stockinette stitch with color 1. After Row 212 SHAPE SHOULDER (watch for neck shaping). FOR SHOULDER, bind off 5 sts. 5x, 6 sts. 2x, (5 sts. 6x, 6 sts. 2x), AT THE SAME TIME, after Row 222, SHAPE NECK. Bind off the center 20 sts., put the needles on the left into holding position and complete the right side first. *ON NECK SIDE, for all sizes, bind off 6 sts. 2x. Move the Cam Box to the left side, turn the Row Counter back to 222 and complete the left half. Follow the instructions from * and don't forget to complete the shoulder shaping.

DK 447

WOMAN'S SCARF & CAP

SIZE: WOMAN'S
YARN: Euro Sport
GRAMS:
Color 1 200
Color 2 100
Color 3 100
Color 4 100
TENSION: 10
GAUGE: 9 sts. 12 rows = 5 cm (2")
OVER EVERY OTHER NEEDLE

Scarf: Norwegian Design (same as DK 448). Cap: Stripes. Knitted OVER EVERY OTHER NEEDLE.

FINISHING: CAP: Weave the open sts. of back seam together and remove the waste yarn. Sew band seam then fold in half sew down and remove the waste yarn. Gather top of hat then sew on a pom-pom. SCARF: Wind the yarn around a 12" cardboard then cut only 1 edge. Use the 4 colors for each fringe. Fold in half and attach to each end of scarf (see picture).

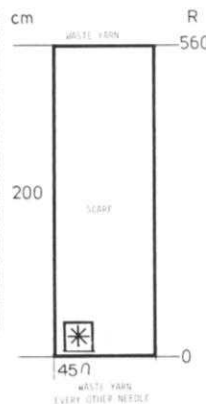

SCARF: OPEN CAST ON, 45 sts. OVER EVERY OTHER NEEDLE. Work in the Norwegian Design, repeating PATTERN I & II to Row 560. Remove on waste yarn. Slip stitch the ends of scarf with color 1. Be sure to work loosely. Remove waste yarn.

PANTS FRONT: I Make 1, reverse 1.

Cast on 45 (53) sts. with color 1 and work Stockinette stitch.

Knit to Row 20.

ON CAM BOX SIDE, increase 1 st. every 8th row 6x.

Knit to Row 73.

ON CAM BOX SIDE, increase 1 st.

2x, 2 sts. 2x, 3 sts. 1x, 4 sts. 1x, then decrease 1 st. every 4th row 3x.

Knit to Row 261. Remove on waste yarn.

Work the 2nd section with reverse shaping, casting on from right to left. Cam Box will be on the LEFT side at Row 0.

LEG BANDS: Sew side seams first, then hang the open sts. of leg back onto the machine with right side facing you, decreasing to 84 sts.

Knit 12 rows Tension 6.

Knit 1 Row Tension 10.

Knit 13 rows Tension 6.

Remove on waste yarn. Fold under and sew down.

DK 448



WOMAN'S 3/4 LENGTH COAT

SIZES: Small Medium
YARN: Euro Sport

GRAMS:
Color 1 600 650
Color 2 150 150
Color 3 100 100
Color 4 100 100

TENSION 10

GAUGE: 9 sts. 12 rows = 5 cm (2")
OVER EVERY OTHER NEEDLE

Stockinette stitch with a Norwegian Design. Punch your own Cards or Follow the Punch Card Illustration.

FINISHING: See General Instructions. Sew Band to front edges and around back neck edge. Fold in half and sew to the inside.

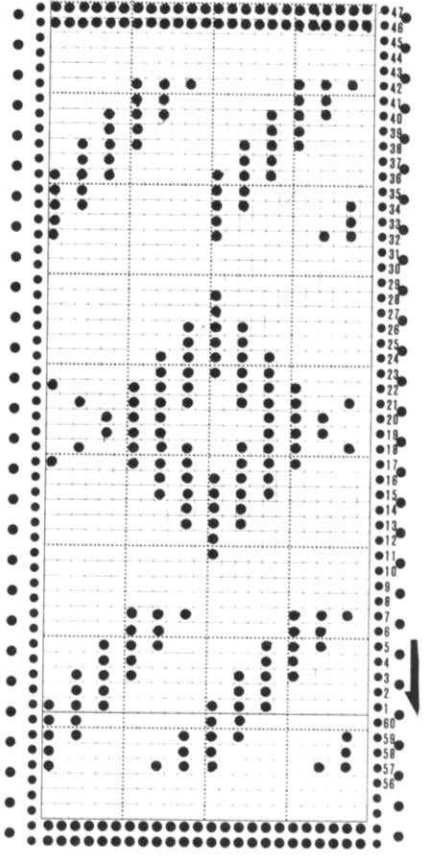
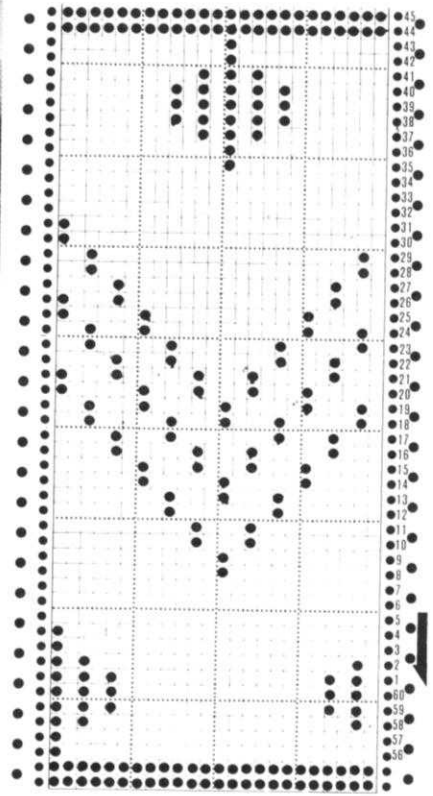

Small

(Medium)

FRONT: I Make 1, reverse 1.

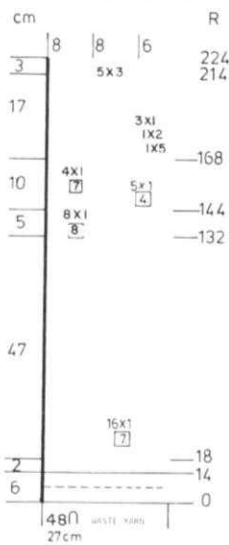
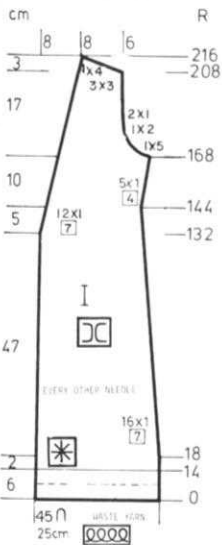

With contrast waste yarn, cast on 45 (48) sts. OVER EVERY OTHER NEEDLE and work Stockinette stitch. Knit 8 to 10 rows, then change to color 1 and put Counter at 0. Knit 6 rows Tension 8, 1 row Tension 10, 7 rows Tension 8. Hang the hem Change to garment Tension. Continue in the Norwegian Design REPEATING Pattern I and II. After Row 18, ON SIDE EDGE, decrease 1 st. every 7th row 16x. Knit to Row 132. ON FRONT EDGE, decrease 1 st. every 7th row 12x, (every 8th row 8x, every 7th row 4x), AT THE SAME TIME, after Row 144, ON SIDE EDGE, increase 1 st. every 4th row 5x. After Row 168, SHAPE ARMHOLE: Bind off 5 sts. 1x, 2 sts. 1x, 1 st. 2x. (5 sts. 1x, 2 sts. 1x, 1 st. 3x). Knit to Row 208 (214) then SHAPE SHOULDER same as the back.

CAP:

With contrast waste yarn, cast on 35 sts. OVER EVERY OTHER NEEDLE. Knit 8 to 10 rows then change to color 1 and put the Counter at 0.

Work Stockinette stitch with REPEATED COLOR STRIPES of

- 2 rows color 1
- 4 rows color 2
- 2 rows color 1
- 4 rows color 4
- 2 rows color 1
- 4 rows color 3
- 2 rows color 1

After Row 144, remove onto contrast waste yarn.

With purl side facing you, hang 1 long edge back onto the machine (EVERY OTHER NEEDLE).

Knit 50 rows Stockinette stitch with color 1. Remove onto waste yarn.

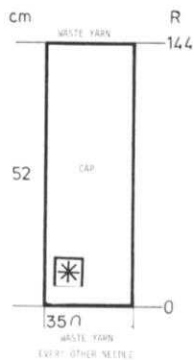

THE PATTERN IS A REPEAT OF 100 ROWS (Using Pattern I and II) as follows.

- *3 rows Color 1
- 11 rows Color 1 + 2
- 3 rows Color 1
- 18 rows Color 1 + 3
- 3 rows Color 1
- 11 rows Color 1 + 2
- 3 rows Color 1
- 9 rows Color 1 + 4
- 3 rows Color 1
- 24 rows Color 1 + 2
- 3 rows Color 1
- 9 rows Color 1 + 4

REPEAT FROM *



Continued

DK 448

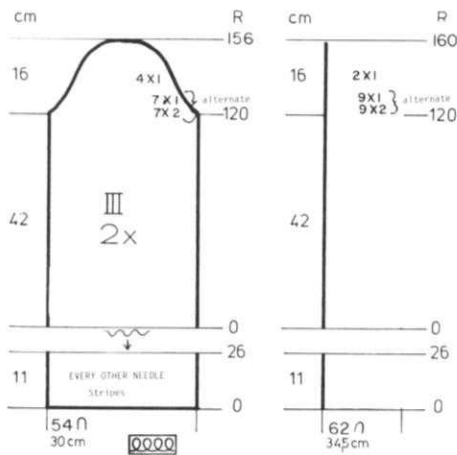

FRONT & NECK BAND:

With color 1, cast on 24 sts. OVER EVERY OTHER NEEDLE and work Stockinette stitch.
With Tension 8, knit approximately 404 rows then remove on waste yarn so that you may pull out any extra rows if need be.

Cast on 54 (62) sts. OVER EVERY OTHER NEEDLE with color 1.
Knit REPEATED COLOR STRIPES of 2 rows color 1, 4 rows color 2, 2 rows color 1, 4 rows color 4, 2 rows color 1, 4 rows color 3, 2 rows color 1.
After Row 26, remove the sts. onto waste yarn.
With knit side facing you, hang the sts. back onto the machine. Put Counter at 0 and work Stockinette stitch.
Knit to Row 120.
SHAPE CAP: ON EACH SIDE, bind off *2 sts. 1x, 1 st. 1x and REPEAT from * 6x more (8x more), then ON EACH SIDE, decrease 1 st. 4x (2x).
After Row 156 (160) bind off.

BACK: II

With contrast waste yarn, cast on 90 (96) sts. OVER EVERY OTHER NEEDLE and work Stockinette stitch.

Knit 8 to 10 rows, then change to garment yarn - color 1 and Put Counter at 0.

Knit 6 rows Tension 8, 1 row Tension 10, 7 rows Tension 8. Hang the hem and continue with garment tension and work the NORWEGIAN Design, REPEATING Pattern I and II.

After Row 18, ON EACH SIDE, decrease 1 st. every 7th row 16x. After Row 144, ON EACH SIDE, increase 1 st. every 4th row 5x.

After Row 168, SHAPE ARMHOLE: ON EACH SIDE, bind off 5 sts. 1x, 2 sts. 1x, 1 st. 2x. (5 sts. 1x, 2 sts. 1x, 1 st. 3x). Knit to Row 208 (214).

SHAPE SHOULDER and watch for Neck Shaping.

FOR SHOULDER, bind off 3 sts. 3x, 4 sts. 1x. (3 sts. 5x).

FOR NECK: After Row 214 (222) bind off the center 12 sts., put the needles on the left into holding position and complete the right side first.

*ON NECK SIDE, bind off 6 sts. 1x, for all sizes.

Bring the needles on the left into working position, knit 1 row in Pattern to the left side, turn the Row Counter back to 208 (214) and complete the left half. Follow the instructions from * and don't forget to complete the shoulder shaping.

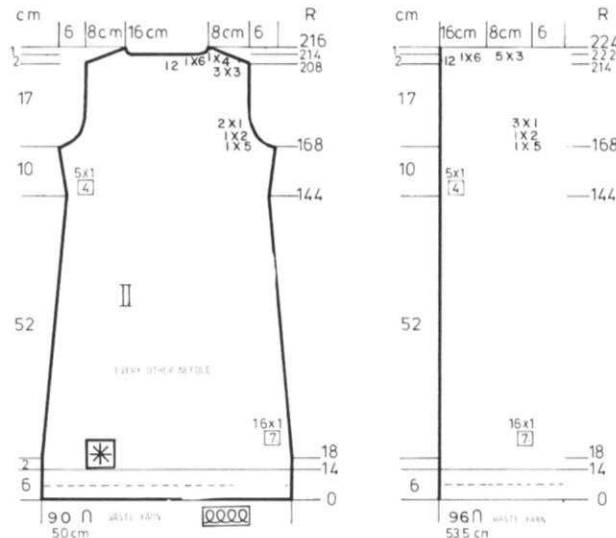

converta tape (new design)

For simple and speedy charting of custom knits.

Price \$8.95

(California residents add Sales Tax)

Shipping charges: \$.65

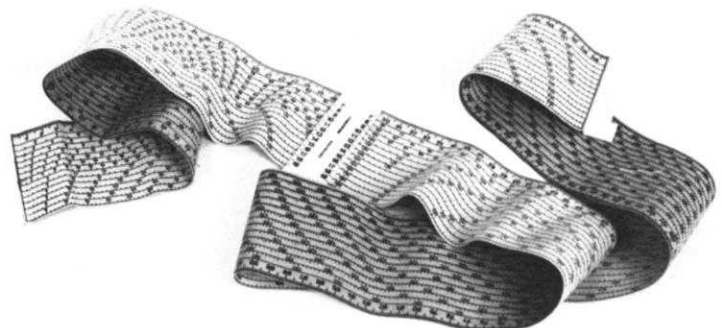

Order direct from KNITKING

— 1128 Crenshaw Blvd., Los Angeles, California 90019



KnitKING News

KNITKING WARDROBE PLAN

In our Editorial for this issue, we talk briefly about our new and popular WARDROBE PLAN... Since its introduction in January of this year, we have enrolled hundreds of members and are beginning to analyze the type and size of garments most needed by the membership... We are preparing materials, garments and Charts accordingly... Some of the specially selected garments will be featured in each issue of KNITKING MAGAZINE commencing with this one.

All owners of KNITKING KH 830 machines are given a membership number that they must use in all correspondence especially when placing orders for Kits and free KNITLEADER CHARTS... If you have purchased a KNITKING KH 830 and KNITLEADER, but have not returned your Guarantee Card, please do so as soon as possible so that your Guarantee is in operation and you can be given a Membership Number... If you purchased your KNITKING KH 830 from a dealer, you can also order kits or any other accessories you need from your dealer.

WARDROBE PLAN KITS

Full sized KNITLEADER CHARTS are available for garment DK 434, HP 436 and the Cover garments DK 445. WARDROBE PLAN members receive these Charts at no charge when they order the yarn kits at the reduced prices shown on the next page... When ordering, be sure to give your Member Number. Non-Members can obtain charts for \$3.50 each when purchased together with a yarn kit. These Charts are only available for the sizes shown in the magazine... You can easily adjust them to suit your own figure... make them shorter or longer... the waist or bust smaller or larger, etc., etc.

KNITKING AM 3 TABLES

We have been out of stock of these excellent tables for over 6 months... but, we have them again and at the same price of \$39.50 complete. They are only suitable for KNITKING AM 3 machines, so please do not order them for any other model. California residents must add Sales Tax. The Shipping costs are \$5.00.

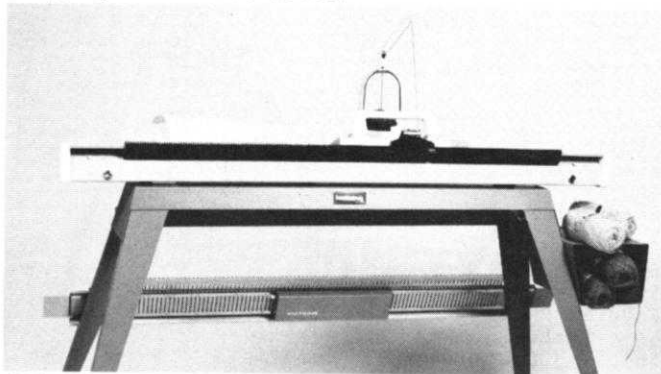

PIANO WIRES FOR ASSEMBLING AND BLOCKING

In the last issue, we told you about the new and easy way of assembling and blocking your garments with the use of PIANO WIRES. They proved so popular that we sold out within three weeks of the

magazine getting on the market. We are well stocked again now, so if you don't already have them, order a set. The price is \$1.95 (California residents add Sales Tax) plus 50¢ Shipping. You receive three long and three short wires in a package and you can throw away your blocking pins and forget basting threads when you use the PIANO WIRES. For full information on their use, check KNITKING NEWS, Volume 13, No. 1 KNITKING MAGAZINE.

PRACTICAL KNITTING HINTS

LOWER THE TENSION FOR BANDS

No one likes to have a loose or ruffled band on a Pullover or a loose sleeve band. To avoid this, you can change the tensions when knitting a band.

If you are working K1, P1 Ribbing, lower the tension one number for the Ribbing section. If you are working a MOCK RIB or a STOCKINETTE Stitch band, you will need to make more of an adjustment in your tensions so that the band will fit well.

A Mock Rib can be knitted with 2 or even 3 tensions lower. When you hang the hem, be sure the stitches LINE UP and to prevent a hole along the hem line, you must either pick up a stitch from the row below and hang it onto each empty needle, or pick up the cross thread below the empty needle, give it a twist and hang it onto the empty needle all along the row. Put ALL the stitches behind the latches and knit them together with 2 or even 3 tensions higher than the garment tension, then turn the tension to the correct one for your garment.

A Stockinette stitch band should be made with graduated tensions. For example: If you are knitting a garment with Tension 6, work the band as follows: Let us say the complete band will take 40 rows, 20 of these for the underhem and 20 for the band. Cast on the stitches, then knit 10 rows Tension 5, 9 rows Tension 4, 1 row Tension 8 (for turning row), 9 rows Tension 4, 10 rows Tension 5. Hang the cast on stitches onto the machine, put the stitches BEHIND the latches and knit 1 row Tension 8 (This will be Row 40 - you hung the hem after Row 39). Turn the tension to the garment tension 6 and continue.

It is important that you knit the doubled stitches together with a larger tension after hanging the hem. Before pressing the sections, always take a ruler or a flat rod, run it through the doubled hem and pull downwards. You are now ready to press your section. Do not EVER press K1, P1 Ribbing, but a MOCK RIB should be pressed after pulling it onto shape.

DISCOUNTS ON YARN KITS

Be sure to check the low prices (on the next page) of Kits to make garments from this magazine. If you are going to take the time to knit, it is a waste of time knitting with cheap inferior yarns. Our Kits are specially discounted to magazine subscribers... You can save the cost of a one year subscription to KNITKING MAGAZINE just by ordering a couple of kits a year. The more you order, the more you save and the better dressed you and your family are.

KITS - For this issue of KNITTING MAGAZINE

KK 422 - Yarn: Allegro			
SIZES:	Teen 6	(8)	[10]
Regular Price	\$22.66	\$30.21	\$31.80
Sale Price	16.66	22.61	23.80
Shipping Costs	1.65	1.65	1.65
HP 423 - Yarn: Binia			
SIZES:	38	(40)	[42]
Regular Price	\$18.07	\$19.46	\$20.85
Sale Price	13.52	14.56	15.60
Shipping Costs	1.65	1.65	1.65
KK 424 - Yarn: Fortissima (every other needle) Double Yarn.			
SIZES:	5/6	(7/8)	[9/10]
Regular Price	\$19.08	\$22.26	\$23.85
Sale Price	14.28	16.66	17.85
Shipping Costs	1.65	1.65	1.65
KK 425 - Yarn: Fortissima (every other needle) Double Yarn.			
SIZES:	4/5	(6/7)	[8/9]
Regular Price	\$20.67	\$23.85	\$25.44
Sale Price	15.47	17.85	19.04
Shipping Costs	1.65	1.65	1.65
KK 426 - Yarn: Fortissima			
SIZES:	6	(7/8)	[9/10]
Regular Price	\$15.90	\$17.49	\$20.67
Sale Price	11.90	13.09	15.47
Shipping Costs	1.65	1.65	1.65
DK 427 - Yarn: Summertime			
SIZES:	7/8	(10/12)	
Regular Price	\$37.62	\$41.80	
Sale Price	28.26	31.40	
Shipping Costs	1.65	1.65	
DK 428 - Yarn: Euro Sport			
SIZES:	8/10	(12/14)	
Regular Price	\$25.80	\$30.96	
Sale Price	19.40	23.28	
Shipping Costs	1.65	2.15	
DK 429 - Yarn: Micaela			
SIZES:	16	(18)	[20]
Regular Price	\$13.93	\$17.91	\$19.90
Sale Price	10.43	13.41	14.70
Shipping Costs	1.65	1.65	1.65
DK 430 - Yarn: Micaela			
SIZES:	16	(18)	[20]
Regular Price	\$11.94	\$13.93	\$15.92
Sale Price	8.94	10.43	11.92
Shipping Costs	1.00	1.00	1.00
DK 431 - Yarn: Summertime			
SIZES:	18/20	(22)	[24]
Regular Price	\$17.91	\$19.90	\$21.89
Sale Price	13.41	14.90	16.39
Shipping Costs	1.65	1.65	1.65
DK 432 - Yarn: Summertime			
SIZES:	18/20	(22)	[24]
Regular Price	\$21.89	\$27.86	\$27.86
Sale Price	16.39	20.86	20.86
Shipping Costs	1.65	1.65	1.65
DK 434 - Yarn: Micaela & Capriccio			
SIZES:	8/10	(12/14)	
Regular Price	\$44.44	\$52.93	For DRESS
Sale Price	33.72	39.71	
Regular Price	\$26.00		For SHAWL
Sale Price	19.50		
Shipping Costs	1.65	1.65	(each Kit)
DK 435 - Yarn: Summertime & Micaela			
SIZES:	7/8	(10/12)	[14/16]
Regular Price	\$27.86	\$29.85	\$31.84
Sale Price	20.86	22.35	23.84
Shipping Costs	1.65	1.65	1.65

HP 436 - Yarn: Vienna			
SIZES:	34/36	(38)	[40/42]
Regular Price	\$17.90	\$19.69	\$23.27
Sale Price	13.40	14.74	17.42
Shipping Costs	1.65	1.65	1.65
DK 437 - Yarn: Fortissima			
SIZES:	7/8	(10)	[12]
Regular Price	\$11.13	\$12.72	\$14.31
Sale Price	8.33	9.52	10.71
Shipping Costs	1.65	1.65	1.65
DK 438 - Yarn: Euro Sport			
SIZES:	12/14	(16/18)	
Regular Price	\$30.96	\$36.12	
Sale Price	23.28	27.16	
Shipping Costs	2.15	2.15	
DK 439 - Yarn: Fortissima			
SIZES:	8/10	(12/14)	
Regular Price	\$25.44	\$27.03	
Sale Price	19.04	20.23	
Shipping Costs	1.65	1.65	
DK 440 - Yarn: Capriccio OR Micaela			
SIZES:	8/10	(12/14)	
CAPRICCIO			
Regular Price	\$58.50	\$65.00	
Sale Price	43.92	48.80	
Shipping Costs	1.65	1.65	
MICAELA			
Regular Price	\$23.88	25.87	
Sale Price	17.88	19.37	
Shipping Costs	1.65	1.65	
HP 441 - Yarn: Binia			
SIZES:	36	(38/40)	[42]
Regular Price	\$19.46	\$22.24	\$25.02
Sale Price	14.56	16.64	18.72
Shipping Costs	1.65	1.65	1.65
KK 442 - Yarn: Euro Sport			
SIZES:	5/6	(7/8)	[9/10]
Regular Price	\$9.03	\$12.90	\$14.19
Sale Price	\$6.79	9.70	10.67
Shipping Costs	1.65	1.65	1.65
KK 443 - Yarn: Micaela & Summertime			
SIZES:	5/6	(7/8)	[9/10]
Regular Price	\$19.90	\$23.88	\$27.86
Sale Price	14.90	17.88	20.86
Shipping Costs	1.65	1.65	1.65
KK 444 - Yarn: Euro Sport			
SIZES:	5/6	(7/8)	[9/10]
Regular Price	\$ 9.03	\$12.90	\$14.19
Sale Price	6.79	9.70	10.67
Shipping Costs	1.65	1.65	1.65
DK 445 - Yarn: Vienna			
SIZES:	12/14	(16/18)	
Regular Price	\$35.80	\$37.59	
Sale Price	26.80	28.14	
Shipping Costs	1.65	1.65	
DK 446 - Yarn: Allegro & Nicole			
SIZES:	7/8	(10/12)	
Regular Price	\$30.41	\$32.00	
Sale Price	22.76	23.95	
Shipping Costs	1.65	1.65	
DK 447 - Yarn Euro Sport			
SIZES:	Woman's		
Regular Price	\$12.90		
Sale Price	9.70		
Shipping Costs	1.65		
DK 448 - Yarn: Euro Sport			
SIZES:	Small	(Medium)	
Regular Price	\$24.51	\$25.80	
Sale Price	18.43	\$19.40	
Shipping Costs	1.65	1.65	

Punch your own Cards

FOR KNITKING 830 - BROTHER 820 - or STUDIO and JUKI Machines

With this inexpensive Kit...

The Punching Accessory is \$5.70

Set of 10 Blank Cards is 4.75

Total \$10.45

(California residents add Sales Tax)

Shipping & Handling Costs 1.50

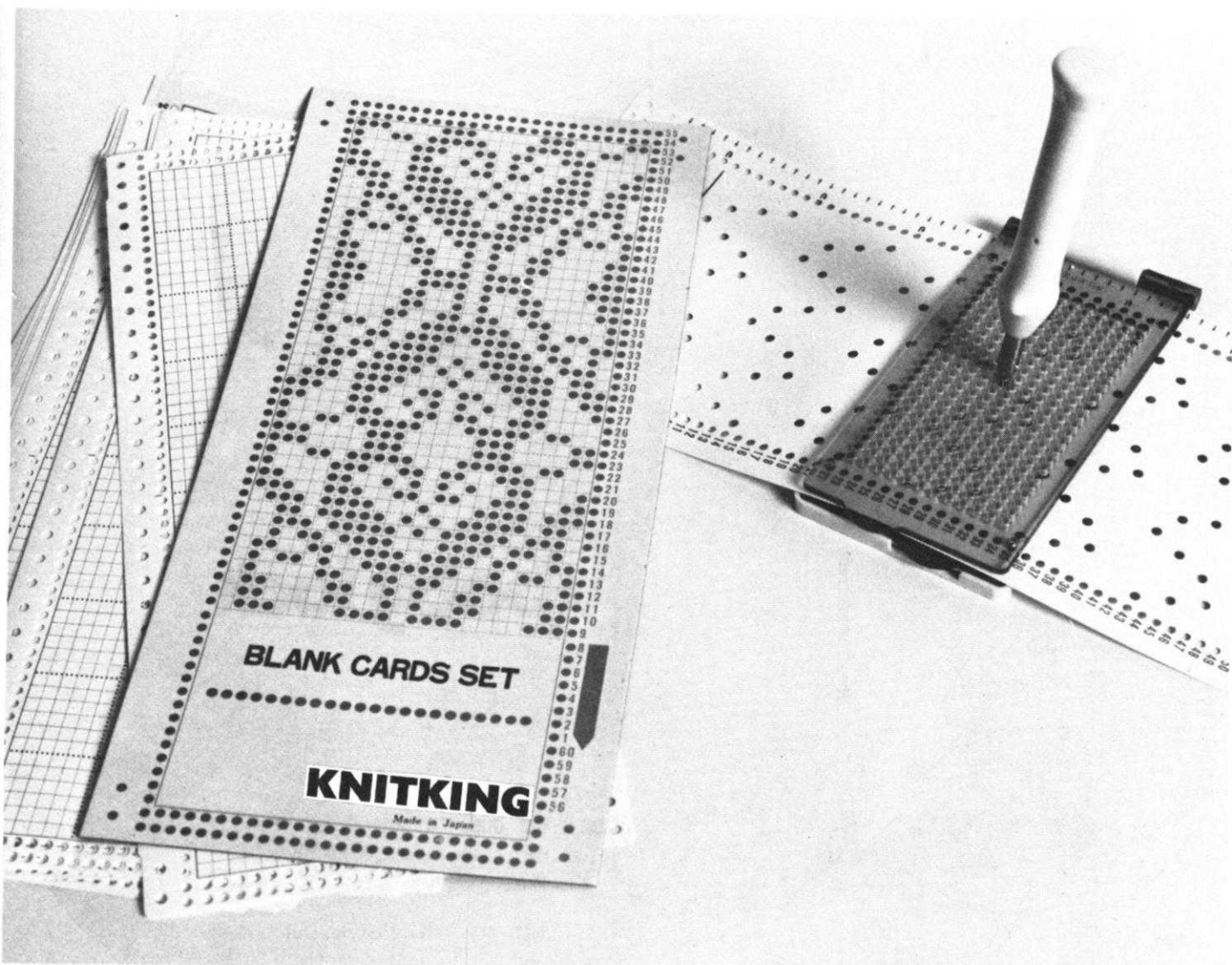

ORDER from your Dealer or DIRECT FROM:
KNITKING - 1128 Crenshaw Blvd., Los Angeles, Calif. 90019

baby blind stitch sewing machine

A brand new design Blind Stitch machine for the home sewer who accepts nothing but the best professional quality finishing.

List Price\$399.00

(California residents add Sales Tax)
Shipping charges: F.O.B. Los Angeles

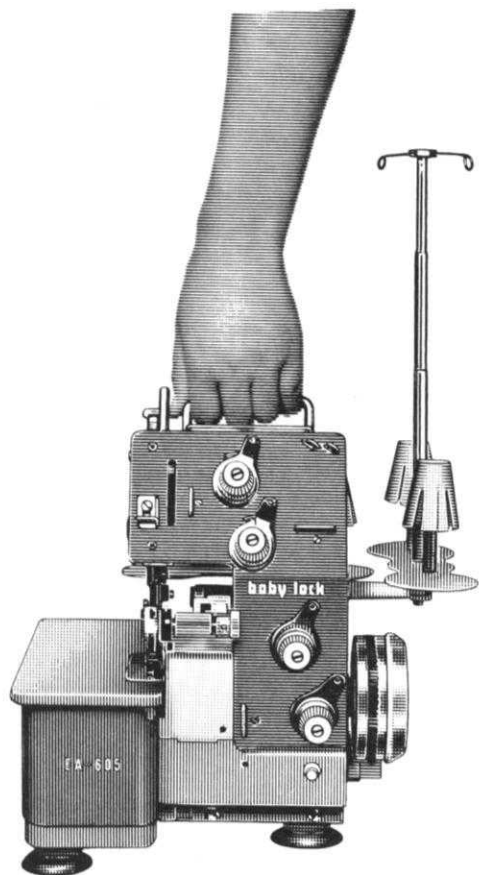
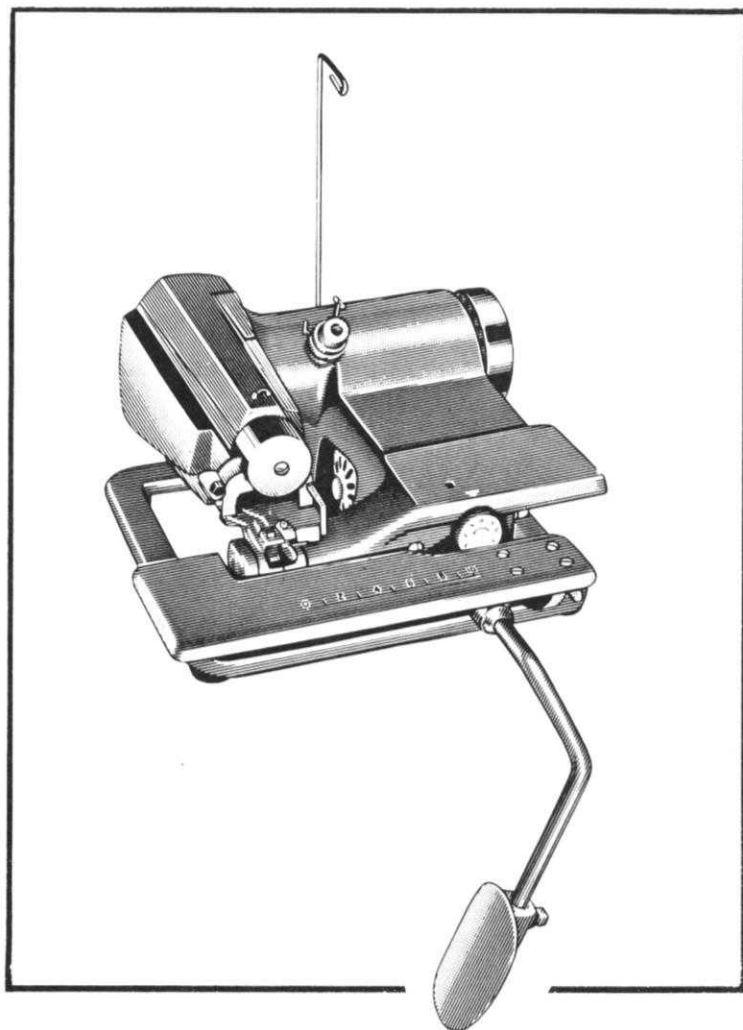

baby lock

MODEL NO. 605. Fabulous Cut, Sew and Overlock machine. Perfect for the entire Family.

List Price \$379.00

MODEL NO. 405. New Style Cut and Overlock Machine. Specially for knit materials.

List Price: \$359.00

(California residents add Sales Tax)

Shipping charges: F.O.B. Los Angeles

DK434



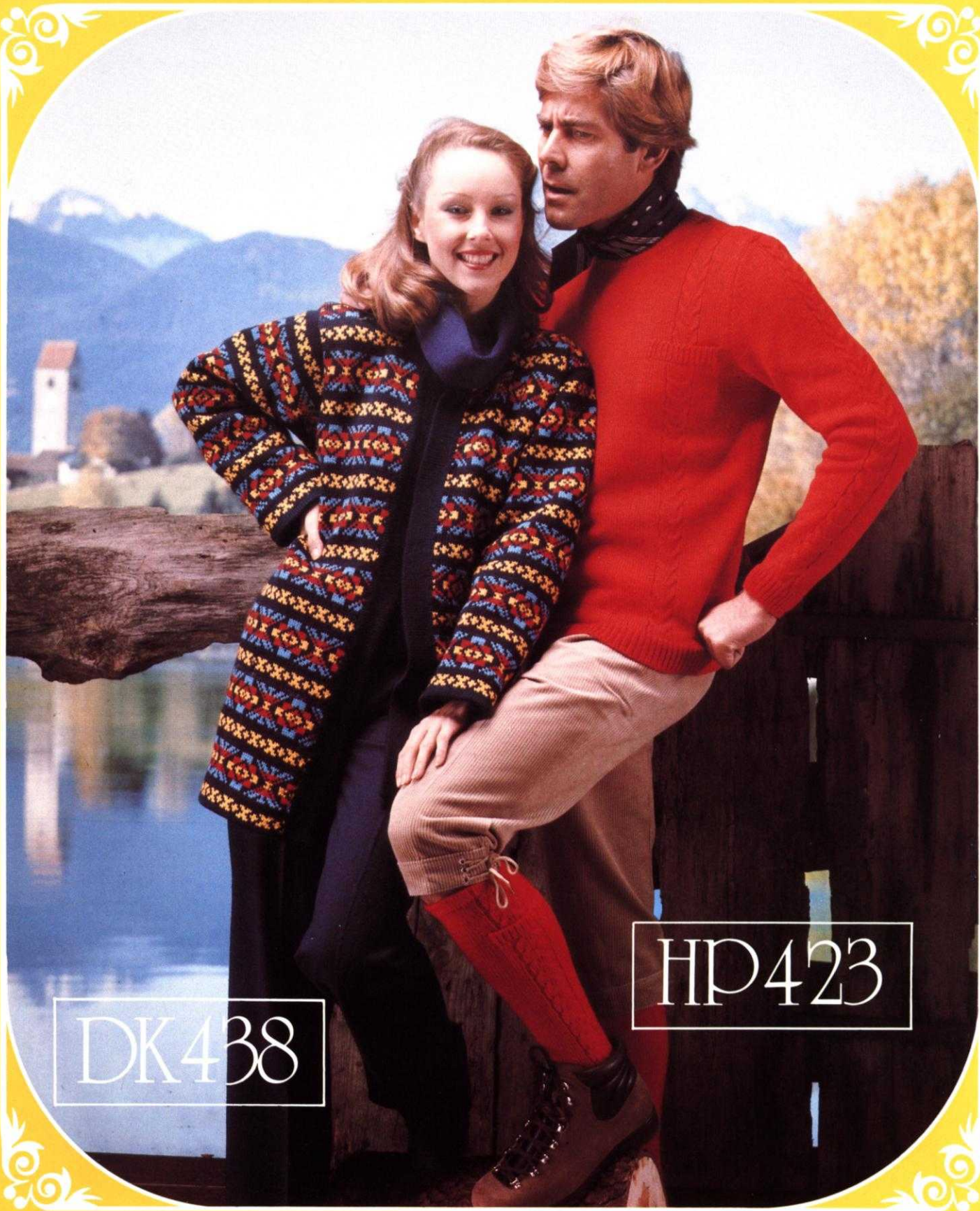

DK438

HP423

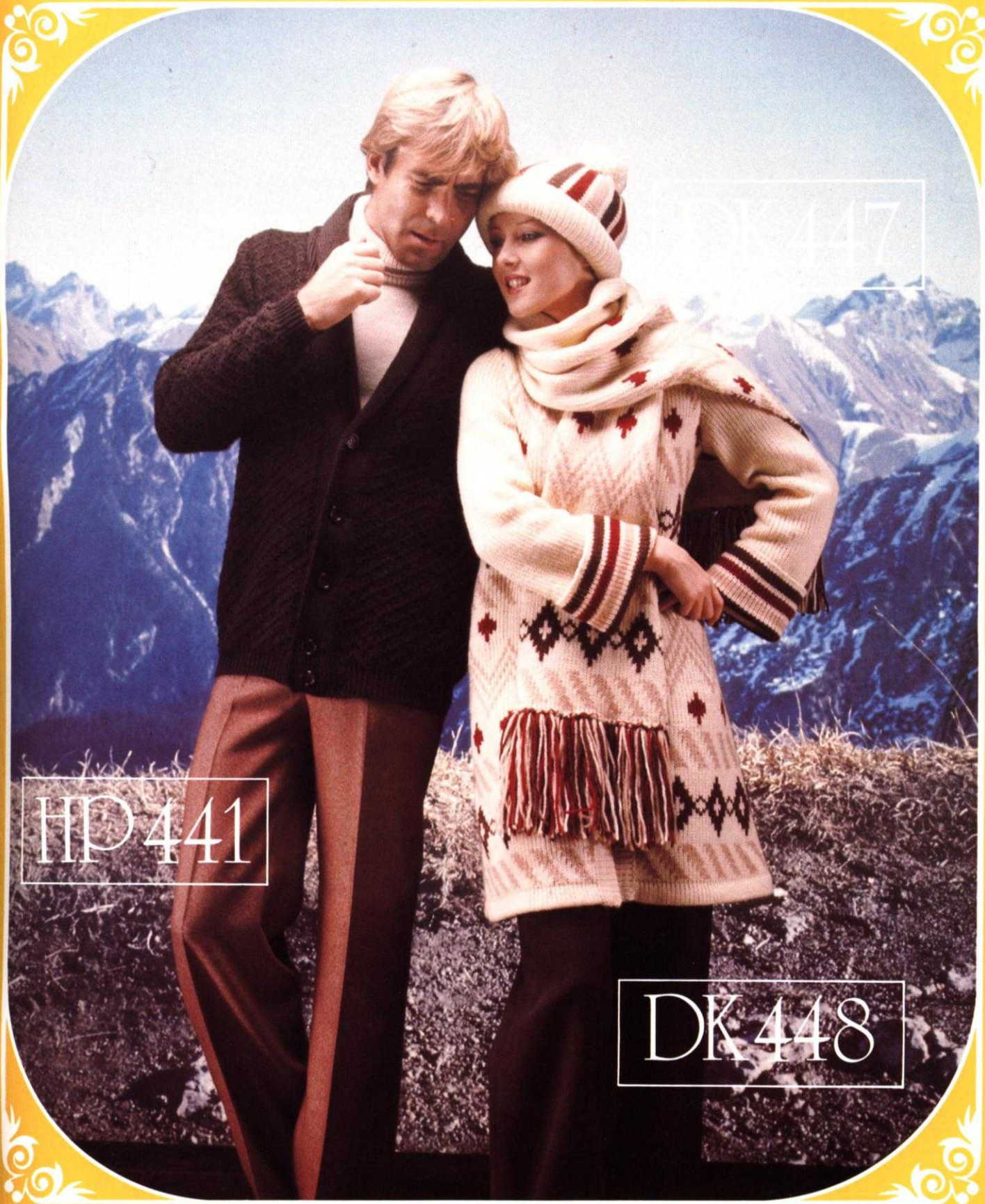

HP 441

DK 447

DK 448



KK 426

KK 425

KK 443



KK 442



KK 424

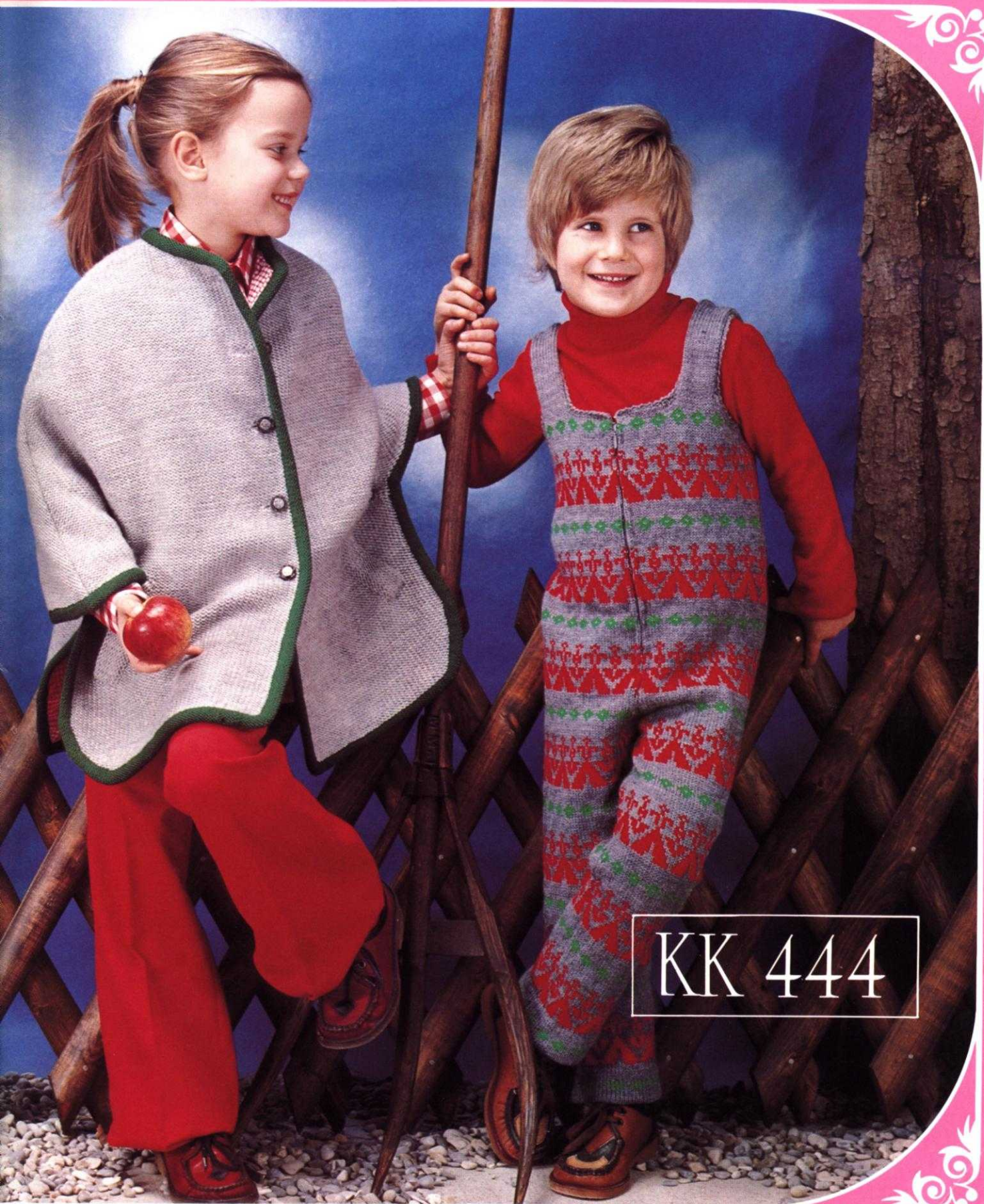

KK 444



KK 422

BUILD YOUR WARDROBE WITH KNITKING

Look Good! . . . Feel Good! . . .

Clothes for all seasons . . . Spring, Summer, Fall, Winter . . . With a **KNITKING** you can knit with fine yarns, sport yarns, dressy yarns, wools or easy care acrylics. In addition to the patterns supplied in the **WARDROBE PLAN**, you can create your own original designs and wear garments that are the only ones of their kind in the world. **CLOTHES FOR ALL THE FAMILY** . . . Women, Men, Girls, Boys and Baby's . . . **KNITKING** designs clothes for them all and patterns, **KNITLEADER CHARTS**, yarns, Punch Cards, etc. are all available to you as a **MEMBER** of the **KNITKING WARDROBE PLAN**.

LACE CARRIAGE

For the first time ever, a Lacemaker that selects needles automatically and knits fine lace in addition to standard lace.

MAIN CARRIAGE

Set the controls for the pattern stitch you want, move the carriage back and forth across the needle bed and all the selection is done for you. The twin yarn feeders allow you to knit two colors in one row automatically.

PUNCH CARD PATTERN SELECTION

You can knit pattern stitches any size you wish from small designs to Fair Isle designs 24 stitches wide that repeat themselves automatically over the entire needle bed or can be isolated for one point patterns. No levers to pull ever . . . Pattern selection is completely automatic.

KNITLEADER KL-116

Just trace your pattern on the sheet and set it in the **KNITLEADER**. It revolves as you knit and tells you when to increase, decrease, etc. You never have to count stitches and rows.

KNITLEADER CHARTS

Charts in the sizes of your choice are supplied **FREE** when you order **KNITKING** yarns at special low **MEMBER** prices.

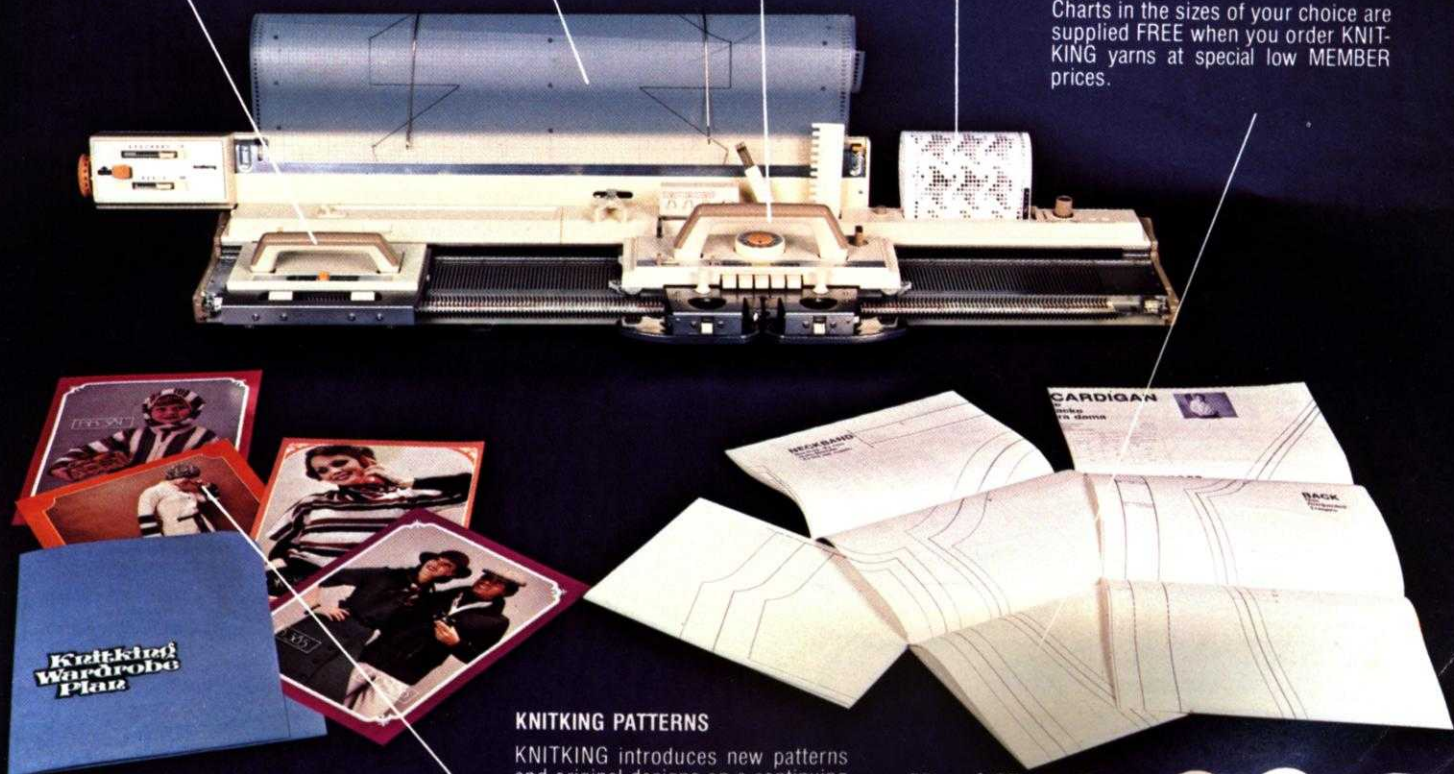

KNITKING PATTERNS

KNITKING introduces new patterns and original designs on a continuing basis. . . . As a member in the **KNITKING WARDROBE PLAN**, you can always dress in the latest fashions for just the cost of the yarn.

KH-830

