

knitking

magazine

jan/feb '73



Another first from Knitking!!!

THE ~~WHIZ KING~~ PATTERN READER with complete Charting Service

- With **WHIZ KING** you know exactly what to do without reference to written instructions.
- With **WHIZ KING** you no longer have to count rows ... Your Pattern Chart turns automatically as you knit.
- With **WHIZ KING** you can knit even the most intricate patterns easily and speedily.
- With a **WHIZ KING** Pattern Reader, even the complete newcomer to machine knitting can immediately knit garments.
- With **WHIZ KING**, Charts are available from **KNITKING MAGAZINE** Patterns in the size of your choice.

PRICE: 49.50 Complete with instructions, practice Charts and illustrations of 50 complete Patterns for the entire family. (California residents add 5% Sales Tax)
Shipping costs \$2.50.

ORDER DIRECT FROM **KNITKING** 1128 CRENSHAW BLVD. • LOS ANGELES, CALIFORNIA 90019

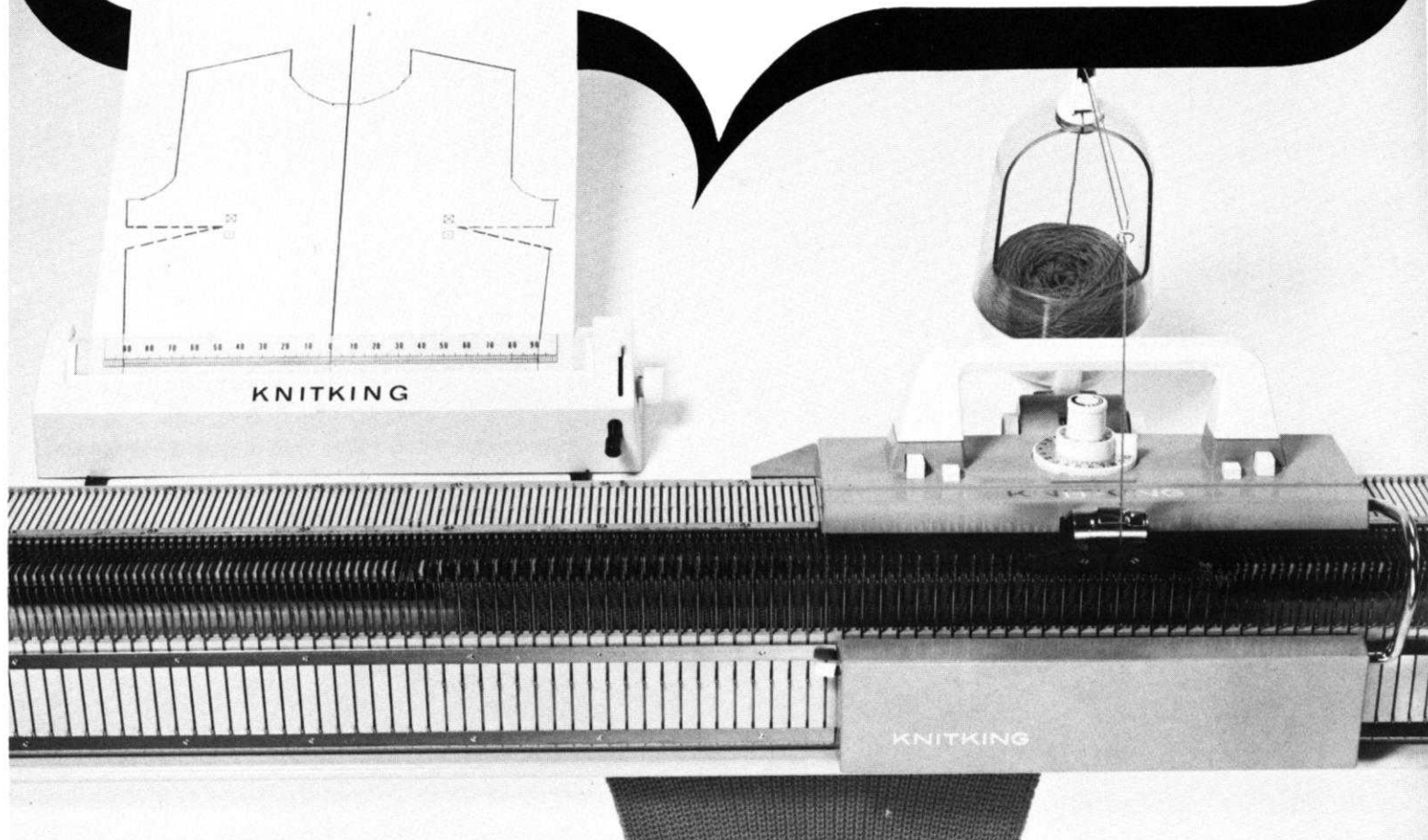

knitking magazine

| INDEX | PAGE NO. |
|---------|--|
| MK 5376 | Child's Dress 9 |
| DK 8093 | Woman's Dress 9 |
| HP 3681 | Man's Pullover 10 |
| HP 3677 | Man's Pullover 11 |
| DP 8106 | Woman's Pullover 12 |
| HP 3682 | Man's Jacket 13 |
| KK 5387 | Boy's Pants, Pullover & Jacket 14 |
| MK 5388 | Girl's Jacket, Pants & Pullover 16 |
| DP 8110 | Woman's Pullover 17 |
| DK 8005 | Woman's Dress with Hood 18 |
| DK 8107 | Woman's Jacket, Pullover, Skirt & Hat 19 |
| DV 8098 | Woman's Bedjacket 22 |
| KK 5380 | Baby's Play Suit 22 |
| DV 8102 | Woman's Bedjacket 24 |
| DK 8137 | Woman's Dress 24 |
| KK 5378 | Child's Play Suit 25 |
| HP 3655 | Man's Pullover & Bolero 26 |
| KG 1955 | Man or Woman's Shrink 28 |
| KG 1956 | Ski Hat :28 |



FRONTPIECE and FRONT COVER

Keep your eye on KNITKING MAGAZINE for all the latest fashion knits in 1973. Be off to a head start with our Cover Models . . . The Dress, DK 8093 sparkles when it is knitted with KNITKING Beatrice Silver, then trimmed with an elegant Braid. In Sizes 10, 12 and 14. Put some sparkle into his life too with a "simulated layer look" Pullover HP 3677. Sizes 38 and 40 are made with Beatrice Silver and

Beatrice Crepe; Size 42 is in Amore with Beatrice Silver . . . and don't forget the darling Dress for a small girl with its brightly striped ruffles. Knit Size 4 with Amore; Size 6 with Allegro.

BACK COVER — MK 5388 and KK 5387

It's a beautiful 3-piece Pantsuit . . . Slacks, Pullover and a gay striped Jacket that is knitted sideways on the machine. Size 8, Allegro; Size 10, Dolly. Brother is at the controls, wearing his favorite sports outfit . . . KK 5387. Slacks, Pullover and a warm zipped Jacket. Sizes 6, 8, 10.

Publisher: KNITKING CORPORATION, 1128 Crenshaw Blvd., Los Angeles, Calif. 90019. Telephone: WEbster 8-2079. Published bi-monthly. Subscriptions: USA — \$6.00 annually, single copies \$1.50; Canada — \$7.00; other parts of the world — \$10.00. The entire contents of KNITKING MAGAZINE are copyright and must not be reproduced in any shape or form without the express permission, in writing of the publisher. COPYRIGHT® by KNITKING CORPORATION 1973.

Printed by George Rice & Sons, Los Angeles, California

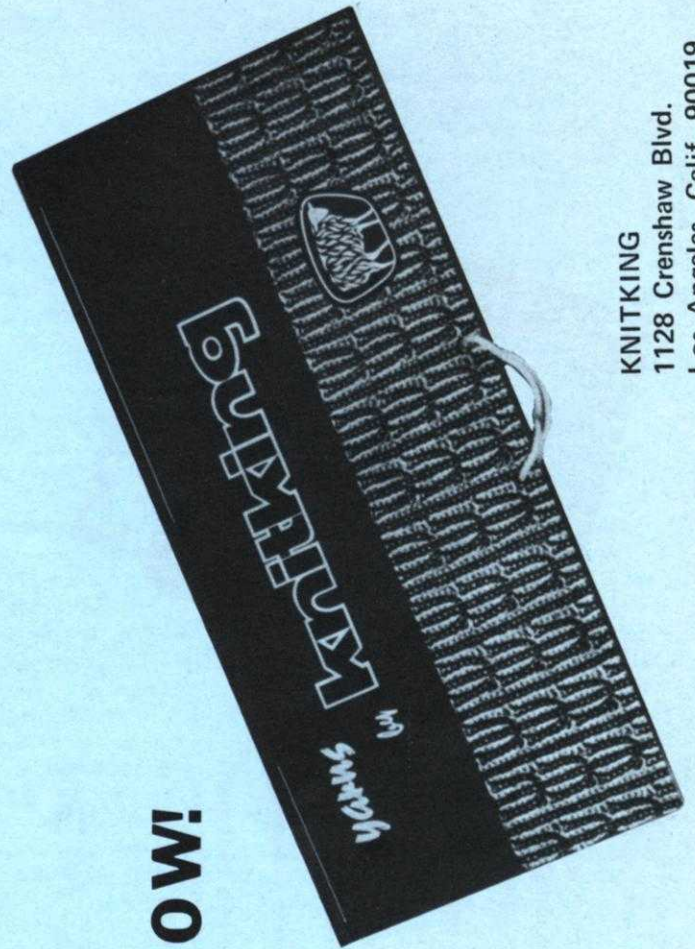

KNITKING
1128 Crenshaw Blvd.
Los Angeles, Calif. 90019

ORDER IT NOW!

Every reader of KNITKING MAGAZINE needs the new big beautiful KNITKING YARN CATALOGUE with over 300 yarn samples . . . the finest from around the world in an unbelievable range of colors.

I enclose one dollar . . .
(California residents add 5% sales tax)
Please RUSH my beautiful new
KNITKING YARN CATALOGUE to me at:

Name _____
Address _____
City _____ State _____ Zip _____

BOOKS by KNITTING

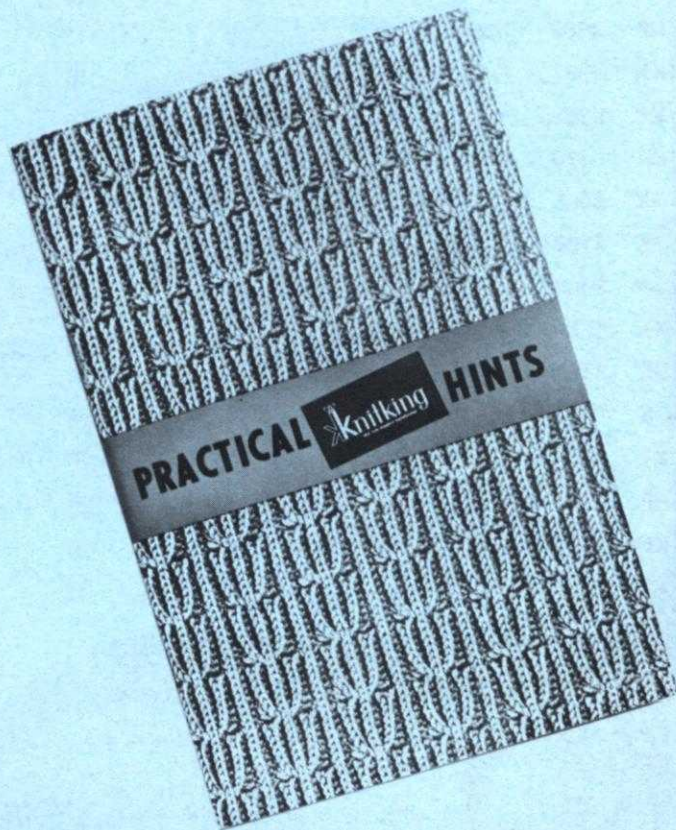

PRACTICAL KNITTING HINTS

We call this book the TEXT BOOK for machine knitters because it answers the many questions that occur in machine knitting, from preparing to knit, taking measurements, shaping, making buttonholes, special effects, bindings, bands and edges, etc., through finishing and blocking. It sells for **\$2.95**

40 cents mailing
Calif. residents add 5% Sales Tax



NEW VOLUME AVAILABLE NOW

A complete eighth volume of KNITTING MAGAZINES with a flexible, transparent plastic cover and specially bound so that it will stay open at any page, is available at the special price of **\$6.95** (plus 95 cents mailing costs).

If purchased separately the magazines would cost a total of **\$9.00**.

The volume contains over 120 fully illustrated complete stylish patterns for all members of the family together with many valuable, practical knitting hints.

There is a very limited number of these volumes available and it will undoubtedly become a collectors item.

If you already have the entire set it will almost certainly be well thumbed and marked. Why not purchase a perfect mint condition volume for your bookshelf and ready reference at any time.

Place your order today and avoid disappointment. Send it to **KNITTING MAGAZINE**, 1128 Crenshaw Boulevard, Los Angeles, California 90019.

editorial

This is a very special Editorial . . . Because it is so special, we ask that you read it in its entirety . . . We believe that what we are going to tell you will mark the greatest advance in knitting machine operation and function since the introduction of hand knitting machines by KNITKING over twenty-five years ago.

The last twenty-five years has seen many tremendous improvements in design and mechanisms of hand knitting machines. They have gone from hand operated basic stockinette machines that required great skill, cast on combs and weights plus tremendous patience on the part of the operator, through the multiple push-button phase with up to forty controls on a machine, a combination of four to six of which had to be moved in the correct sequence every time a pattern stitch was made, up to some modern machines that function entirely with "punch cards" and the fantastic new AM 3 KNITKING, the only Cam operated hand knitting machine in the world . . . !!

An absolutely unlimited number of fancy stitches and designs can be made on the AM 3 and you do not need punch cards, cast-on combs, weights or innumerable controls . . . Insert a Cam and then with one Central Control Knob (set it once, it automatically resets itself) you produce the Pattern Stitch needed . . . With one Button Control, you never have to memorize what button you pushed last and KNITKING machines knit with any weight of yarn from fine crochet cotton to heavy thick and thin or loopy yarns . . . The KNITKING P3 Ribber is inserted with one movement of the hands and it too, is controlled by the one Central Control on the Main Machine . . . KNITKING Ribbers never need complicated cast-on combs or weights and yet they knit many thousands of fancy ribbed stitches easily and automatically.

Throughout this entire period of time, KNITKING through its parent company in West Germany has been the trend setter, the company that designs knitting machines entirely with the operator in mind and provides complete service to the machine knitter in the form of Patterns and Pattern Magazines . . . instruction and practical knitting hints . . . plus yarns, etc. . . Buy any brand of knitting machine other than KNITKING in North America and you invariably design your own garments, chart your own garments or you alter KNITKING patterns or hand knit patterns in order to satisfy your needs . . . There are many talented machine knitters that do this happily and efficiently, but they are in the minority . . . It is the aim of KNITKING to satisfy the demands of all machine owners and

to provide a Pattern Service that will make and keep them happy irrespective of the brand of machine they own . . . Which brings us to our new innovation . . . A Pattern Reader (sometimes called a Charting Machine) that can be adapted to practically any type of machine . . . PLUS . . . and it is a VERY BIG PLUS . . . a continuing Pattern Chart Service.

Many readers will say that Charting Machines have been on the market for two or three years now and we will, of course, agree with them, but again, if you bought a Charting Machine, it was necessary to draw your own charts before you could use your machine and again, few people have sufficient engineering skill and talent to prepare their own charts with the result that most Charting Machines are unused.

We have been developing our Pattern Reader for several years now. We could have introduced the device itself sometime ago but we deliberately refrained from doing so until we were able to launch a complete Pattern Service for our Pattern Reader . . . Well, we have done it . . . and the time is NOW . . . The WHIZ KING PATTERN READER is here and ready to solve the biggest problem in regard to the operation of knitting machines .!! KNITKING will supply Charts from KNITKING MAGAZINE garments in the size of your choice . . . You insert a Chart in your WHIZ KING PATTERN READER (just as you would a piece of paper in a typewriter) and your knitting follows the lines of the Chart . . . You no longer need worry about rows or row numbers . . . You increase or decrease whenever your WHIZ KING tells you to without referring to written instructions at all . . . Read your Chart and by following the lines on it, you will produce knitting without errors . . . evenly and speedily . . . Even the complete newcomer to machine knitting (after learning the basic operation of her machine) can confidently go immediately into the production of garments . . . Nothing quite like this has ever been done before and KNITKING is proud to be the company that is doing it . . . With the WHIZ KING PATTERN READER, the knitting of complete garments has been simplified beyond belief and we forecast that with its introduction, many thousands of heretofore unused knitting machines will be removed from storage and put into operation . . . There will be renewed zest and enthusiasm for knitting machines.

One of the many remarkable features of the WHIZ KING is its relatively low price . . . Lower than any other charting machine on the U.S. market and with the only complete charting service available . . . The price is \$49.50 . . . You get some practice charts with your WHIZ KING, plus an Instruction Book and a book illustrating fifty garments for all members of the family and for which Charts in a variety of sizes are immediately available . . . There will be a nominal charge for each set of Charts and it will vary according to the number of pieces to a garment . . . A simple sleeveless Sheath, for example, will only need two Charts (one for each of the pieces). A complete outfit will need several Charts and will cost a little more . . . If, however, you knit your garments with the beautiful KNITKING YARNS that the original KNITKING MAGAZINE garments were made with, we will furnish Charts FREE OF CHARGE . . . !! Please go ahead . . . order your WHIZ KING PATTERN READER now and be one of the first to acknowledge it as the greatest innovation since KNITKING'S original Hand Knitting Machine.

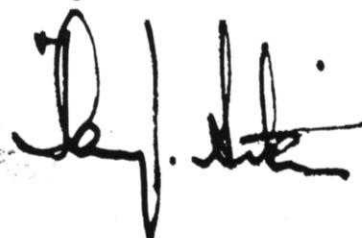





HP 3681 and HP 3682 — For his leisure time, your Sportsman will be delighted to wear a striped Pullover (HP 3681) with a high turtle neck Collar . . . The sharp looking Jacket (HP 3682) boasts the very new fuller Sleeve treatment with snug Cuffs. Large pockets have buttons on the flaps. Both garments are made with the same yarn. Size 40 and 42 with KNITKING Allegro; Size 46 with Dolly Dralon.

DP 8106 — Uneven stripes on a Pullover are flattering . . . especially when the stripes are separated with a solid color Yoke to frame a pretty face. Tiny buttons go two-by-two at the neck opening. Size 8 is knitted with KNITKING Beatrice; Size 12 and 14 with Regia.

STRIPES FOR SPORTS



**jac40
is
a must**

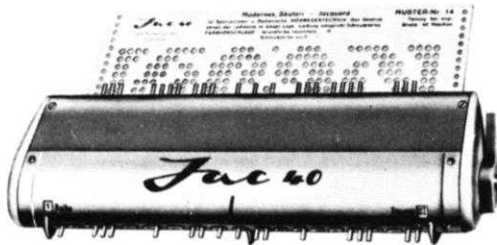

**for fast easy knitting of
Jaquard and Ski-sweater
designs**

Patterns are selected — row by row —
through a pre-stamped
card that is fed into the Jac.



There are over 300 cards available and illustrations of them
are included with each Jac.

Jac 40's are made for most brands of machines. When order-
ing be sure to specify your brand of knitter as needle spacings
vary. Simple to use and an essential tool for the modern
knitter, Jac 40's are \$26.95 complete with 3 cards for prac-
ticing the 3 techniques, plus complete instructions.

Order from your dealer or direct from
KNITKING

1128 Crenshaw Boulevard, Los Angeles, Calif. 90019

Shipping Cost \$1.25 — California residents add 5% sales tax.

DP 8110 — Keep warm . . . be beautiful . . . Wear a
Norwegian Design Pullover, knitted in two colors, on
the ski slopes of your winter vacation resort. The
Front and Back sections are in the Norwegian Design,
the Sleeves are stockinette stitch with ribbed Bands.
The high rolled Collar is in ribbing. Follow the Line
Drawing or you can use your JAC 40 and Pattern No.
460. Knit size 12 with KNITKING Allegro; Size 16
with Flamingo.



For Winter Sport and Après-Ski



THE SPORTS ENSEMBLE



DK 8107 — Four-piece Bonanza . . . The newest trick from our top Designers is vertical stripes for a Jacket knitted sideways using Stockinette Stitch. Knit the swinging pleated Skirt in sections. The Pullover and jaunty Hat have ribbed Bands. For Size 12, use KNITTING Allegro; Size 14, Alanda.



NEW! NEW!! NEW!!!

1. THREE COLOR YARN FEEDER

For Easy Multi-Color Knitting - Jacquard Designs, etc. Feeders are Self-Adjusting. Fits AM 3 Model KNITKING only. Price - \$17.50 plus \$1.50 Shipping costs (Calif. residents add 88 cents Sales Tax).

2. AUTOMATIC COMPENSATOR FOR INCREASING - DECREASING

Simple to use . . . Overcomes the need to reset Dial when increasing or decreasing . . .

Send your AM 3 Cam Box to KNITKING (pack it in a good sized box stuffed with tightly rolled sheets of newspaper). We will service it completely . . . fit new Controls and supply new set (eleven) of Cams. Your old Cams are not suitable for the new Controls.

Price - \$19.50 plus \$2.00 Shipping costs (Calif. residents add 98 cents Sales Tax).

Order Direct From **KNITKING**

1128 Crenshaw Blvd. • Los Angeles, California 90019

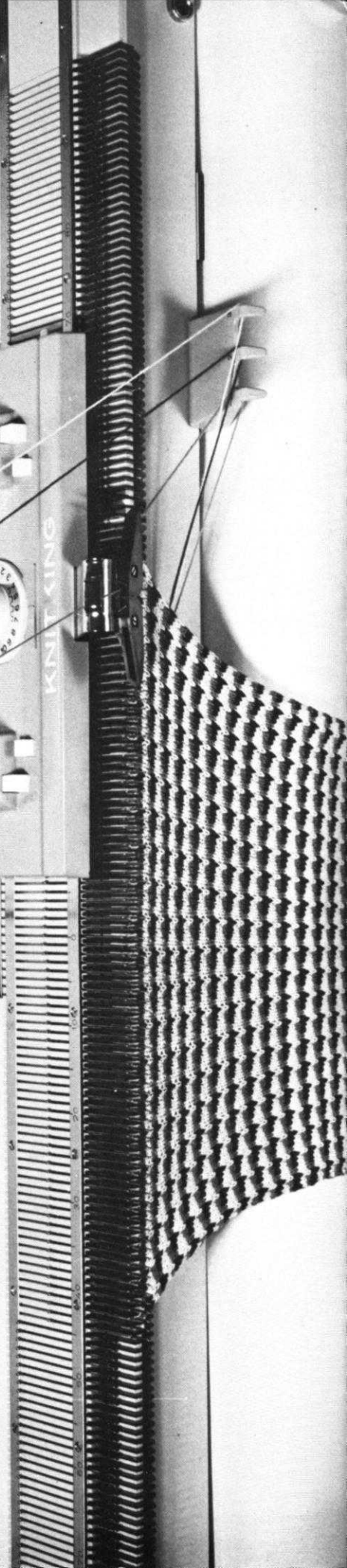
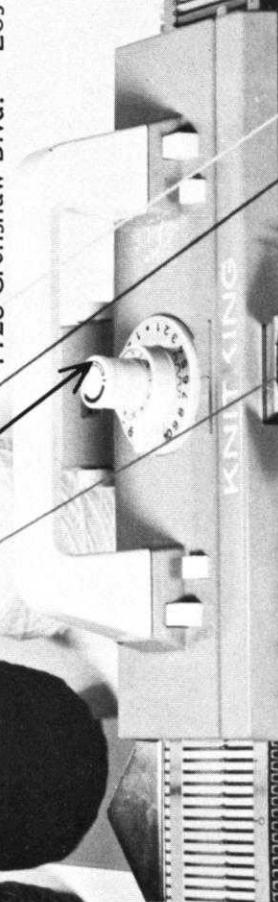
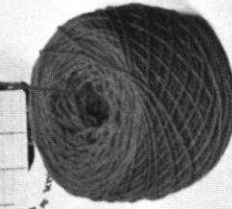
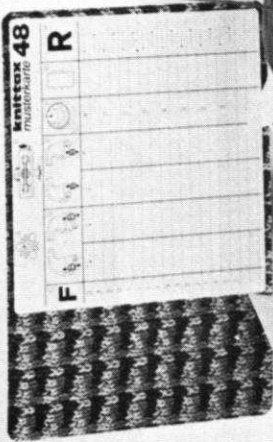

MK 5376

| | | |
|---------------|---|-------------------|
| SIZE: | 4 (Chest 23"-24") | 6 (Chest 25"-26") |
| YARN: | Amore | Allegro Dralon |
| 50 gr. BALLS: | 3 Color 1 | 3 Color 1 |
| Both Sizes: | Small amounts of 8 different color yarn | |
| TENSION: | 6 to 8 | 5 to 7 |
| GAUGE: | 2" 16 sts. 25 rows | 15 sts. 23 rows |

The instructions are the same for both sizes. PATTERN: Stockinette Stitch with Color Stripes at lower edge and sleeve edges. DECREASES: Hang the 3rd st. onto the 2nd st., then move the end sts. inward to fill the empty needle. To form the hems, hang the cast-on sts. back onto the machine behind the latches, then knit the following row with 1 to 2 tension settings higher.

FINISHING: Block all sections. Gather the flounce for the sleeves to the width of the lower sleeve edges, then sew the flounce in place. Gather and sew 1 flounce to the back section and 1 flounce to the front section. Join front and back section at sides and shoulders. Sew the sleeves together and set in. Work 1 row of single crochet around the neckline and back opening, then work 1 row of reverse single crochet around the neckline. Work 3 loops on 1 side and sew 3 buttons to other side of back opening.



Move the Cam Box to the left side, turn the Row Counter back to 192 and complete the left half. Follow the instructions from*.

*ON CAM BOX SIDE, bind off 3 sts. after Row 193; 2 sts. after Rows 195, 197; 1 st. after Rows 199, 201, 203. For SHOULDER bind off 4 sts. after Rows 206, 208, 210, 212, 214, 216.

ROWS 169 to 192: Knit even, then bind off the center 10 sts., put the needles on the left side into holding position and complete the right half first.

Work the front section the same as the back section to ROW 168.

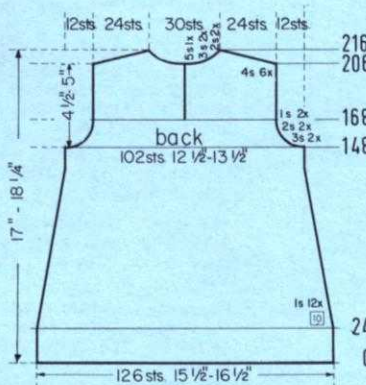
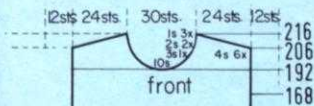

ROWS 9 to 36: In the same order as on the dress flounce, work 4 rows of each color. After Row 36 bind off all sts.

ROWS 0 to 8: Knit even, then form the hem and continue with color 3.

Cast on 95 sts. with color 2 and work stockinette st.

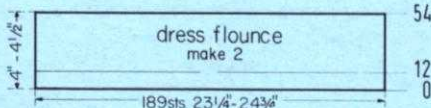
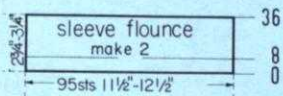

ON CAM BOX SIDE, bind off 3 sts. after Rows 20, 21, 22, 23; 2 sts. after Rows 24, 25, 26, 27, 28, 29. ON EACH SIDE, hang the 1st st. onto the 2nd st. after Rows 30, 32, 34, 36, 38, 40, 42, 44, 46, 48, 50. ON CAM BOX SIDE, bind off 2 sts. after Rows 52, 53, 54, 55, 56, 57; 8 sts. after Row 58.

ROWS 0 to 20: Knit even.

Cast on 66 sts. with color 1 and work stockinette st.

Move the Cam Box to the left side, turn the Row Counter back to 168 and complete the left half. Follow the instructions from*.

ON CAM BOX SIDE, bind off 4 sts. after Row 206 (EVEN ROWS = SHOULDER SHAPING); 5 sts. after Row 207 (ODD ROWS = NECK SHAPING); 4 sts. after Row 208; 3 sts. after Row 209; 4 sts. after Row 210; 3 sts. after Row 211; 4 sts. after Row 212; 2 sts. after Row 213; 4 sts. after Row 214; 2 sts. after Row 215; 4 sts. after Row 216.

*ROWS 169 to 206: Knit even.

ON CAM BOX SIDE, bind off 3 sts. after Rows 148, 149, 150, 151; 2 sts. after Rows 152, 153, 154, 155; 1 st. after Rows 156, 157, 158, 159, then knit to Row 168, put 39 needles on the left side into holding position and complete the right half first. (For the FRONT Section knit to Row 168, but do not divide the sts.)

ON EACH SIDE, decrease 1 st. after Rows 24, 34, 44, 54, 64, 74, 84, 94, 104, 114, 124, 134, then knit to Row 148.

ROWS 0 to 24: Knit even.

Cast on 126 sts. with color 1 and work stockinette st.

ROWS 13 to 54: Work 6 rows color 3, 6 rows color 4, 6 rows color 5, 6 rows color 6, 6 rows color 7, 6 rows color 8. After Row 54 bind off all sts. Work the second dress flounce the same.

ROWS 0 to 12: Knit even, then form the hem and continue with color 3.

Cast on 189 sts. with color 2 and work stockinette st.

DK 8093

| | | | |
|---------------|--------------------------------------|-------------------|-------------------|
| SIZE: | 10 (Bust 32 1/2"-33 1/2") | 12 (Bust 34"-35") | 14 (Bust 36"-37") |
| YARN: | Beatrice silver | Melodie | Melodie |
| 50 gr. BALLS: | 17 | 18 | 19 |
| TENSION: | 4 to 6 | 5 to 7 | 6 to 8 |
| GAUGE: | 2" 17 sts. 23 rows | 16 sts. 22 rows | 15 sts. 21 rows |
| ZIPPER: | 22" | 23" | 24" |
| ALL SIZES: | 4 1/2 yards silver trim 1 1/2" wide. | | |

The instructions are the same for all sizes. PATTERN: Stockinette Stitch. DECREASES: Hang the 4th st. onto the 3rd st., then move the end sts. inward to fill the empty needle. Begin thr skirt DARTS by hanging the sts. together as marked on the Diagram, then move the sts. together to fill the empty needles. The following decreases for the Darts lie directly above. INCREASES: Move the 2 end sts. 1 needle outward, then place the 3rd st. from the row below onto the empty needle.

FINISHING: Block all sections. Join front and back section at sides and shoulders. Sew the sleeves together and set in. Turn under 18 rows on lower edge and 13 rows on sleeve edges and hem to wrong side. Work 1 row of single crochet around the back opening. Gather the front part of the collar lightly, on the cast-on and bound-off edges, then sew 1 edge of the collar to inside and 1 edge to the outside of neckline. Fold the collar to outside, having the seam line in the center of the collar on the wrong side. Sew the zipper in place. Sew the silver trim to the sleeves and shoulders as shown in the picture. Make a tie belt with the remaining trim. You may line the skirt section with taffeta.



Continued on pages 10 & 11

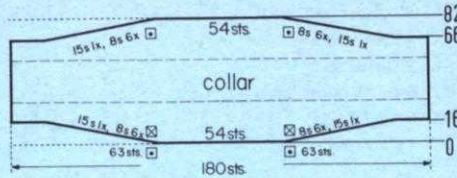
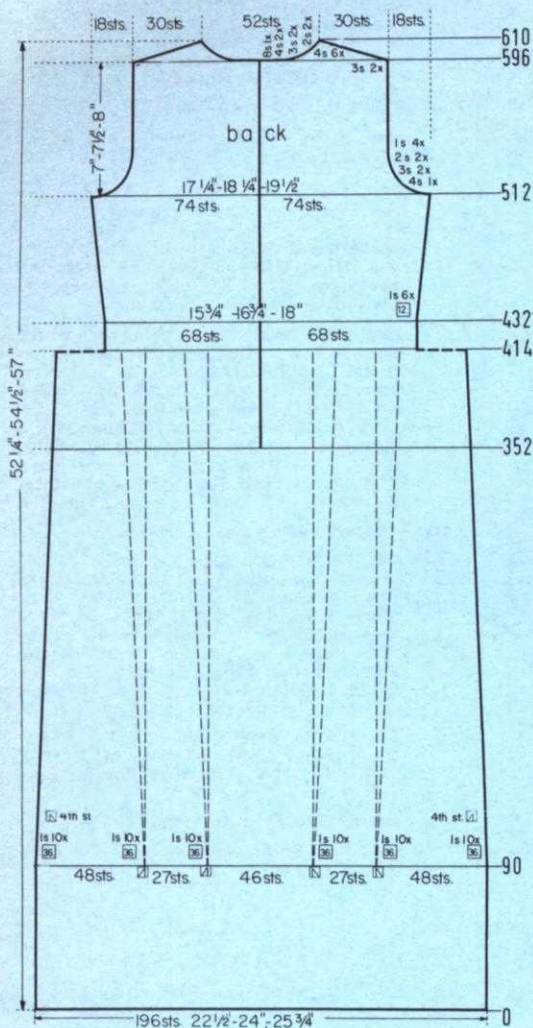

Move the Cam Box to the left side, turn the Row Counter back to 352 and complete the left half. Follow the instructions from*.

ON CAM BOX SIDE, bind off 3 sts. after Row 596 (EVEN ROWS = SHOULDER SHAPING); 8 sts. after Row 597 (ODD ROWS = NECK SHAPING); 3 sts. after Row 598; 4 sts. after Rows 599, 600, 601, 602; 3 sts. after Row 603; 4 sts. after Row 604; 3 sts. after Row 605; 4 sts. after Row 606; 2 sts. after Row 607; 4 sts. after Row 608; 2 sts. after Row 609; 4 sts. after Row 610.

ON CAM BOX SIDE, bind off 4 sts. after Row 512; 3 sts. after Rows 514, 516; 2 sts. after Rows 518, 520; 1 st. after Rows 522, 524, 526, 528, then knit to Row 596.

ON CAM BOX SIDE, increase 1 st. after Rows 432, 444, 456, 468, 480, 492, then knit to Row 512.

*Continue to decrease 1 st. ON CAM BOX SIDE and 1 st. for EACH DART after Rows 378, 414, then knit to Row 432.

Decrease 1 st. ON EACH SIDE and 1 st. for EACH DART after Rows 90, 126, 162, 198, 234, 270, 306, 342, then knit to Row 352, put 74 needles on the left side into holding position (Or put the 74 sts. onto a stitch holder) and complete the right half first. (For the FRONT Section knit to Row 352, but do not divide the sts).

ROWS 0 to 90: Knit even.

Cast on 196 sts. and work stockinette st.

Cast on 180 sts., work stockinette st. and Short Rows. ON OPPOSITE SIDE of CAM BOX put into holding position 63 sts. after Rows 0, 1. ON OPPOSITE SIDE of CAM BOX bring back into working position 8 needles after Rows 2, 3, 4, 5, 6, 7, 8, 9, 10, 11, 12, 13; 15 needles after Rows 14, 15, then knit to Row 66 and work Short Rows. ON OPPOSITE SIDE of CAM BOX put into holding position 15 needles after Rows 66, 67; 8 needles after Rows 68, 69, 70, 71, 72, 73, 74, 75, 76, 77, 78, 79. ON OPPOSITE SIDE of CAM BOX bring all needles back into working position after Rows 80, 81. After Row 82 bind off all 180 sts.

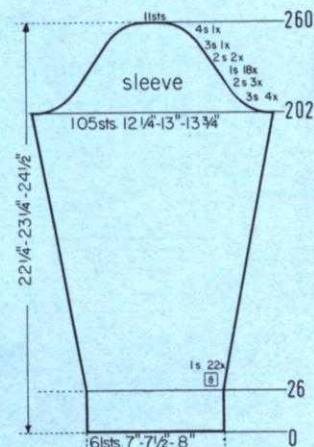
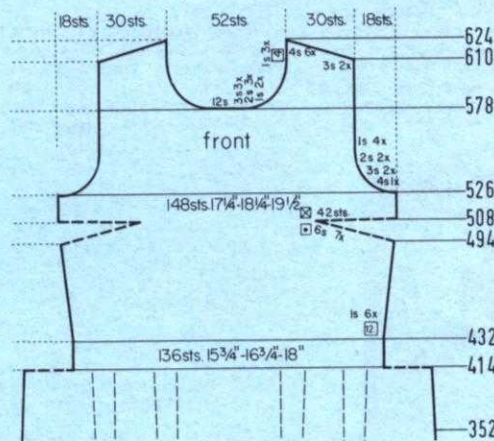

HP 3681

| SIZE: | 40 (Chest 39"-40") | 42 (Chest 42"-43") | 46 (Chest 46"-47") |
|---------------|------------------------|------------------------|------------------------|
| YARN: | Allegro Dralon | Allegro Dralon | Dolly Dralon |
| 50 gr. BALLS: | 6 Color 1 4 Color 2 | 7 Color 1 4 Color 2 | 8 Color 1 6 Color 2 |
| TENSION: | 6 to 8 | 7 to 9 | 8 to 10 |
| GAUGE: | 2" 15 sts. 21 rows | 14 sts. 20 rows | 13 sts. 19 rows |

The instructions are the same for all sizes. PATTERN: Stockinette Stitch with repeated Color Stripes as marked in the Diagrams. EDGES: K1, P1, Ribbing. INCREASES: Move the 2nd st. 1 needle outward, then place the 3rd st. from the row below onto the empty needle.

FINISHING: Block all sections. Join front and back section at sides and shoulders. Sew the sleeves together and set in. Join short ends of collar, then sew the collar to neckline and fold over to outside.

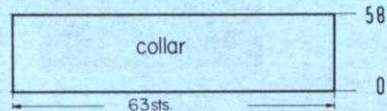

Cast on 163 sts. with color 1 and work 58 rows K1, P1, Ribbing, then bind off all sts.

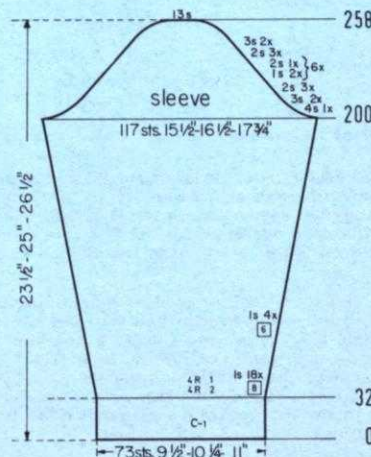

ON CAM BOX SIDE, bind off 4 sts. after Rows 200, 201; 3 sts. after Rows 202, 203, 204, 205; 2 sts. after Rows 206, 207, 208, 209, 210, 211; 1 st. after Rows 212, 213, 214, 215; 2 sts. after Rows 216, 217; 1 st. after Rows 218, 219, 220, 221; 2 sts. after Rows 222, 223; 1 st. after Rows 224, 225, 226, 227; 2 sts. after Rows 228, 229; 1 st. after Rows 230, 231, 232, 233; 2 sts. after Rows 234, 235; 1 st. after Rows 236, 237, 238, 239; 2 sts. after Rows 240, 241; 1 st. after Rows 242, 243, 244, 245; 2 sts. after Rows 246, 247, 248, 249, 250, 251, 252, 253; 3 sts. after Rows 254, 255, 256, 257; 13 sts. after Row 258.

ON EACH SIDE, increase 1 st. after Rows 32, 40, 48, 56, 64, 72, 80, 88, 96, 104, 112, 120, 128, 136, 144, 152, 160, 168, 176, 182, 188, 194, then knit to Row 200.

ROWS 0 to 32: Knit even, then change to stockinette st. and work the repeated Color Stripes as marked in the Diagram.

Cast on 73 sts. with color 1 and work K1, P1, Ribbing.

Continued on page 12

HP 3677

Move the Cam Box to the left side, turn the Row Counter back to 578 and complete the left half. Follow the instructions from*.

*ON CAM BOX SIDE, bind off 3 sts. after Rows 579, 581, 583; 2 sts. after Rows 585, 587, 589; 1 st. after Rows 591, 593, 595, 599, 603. For SHOULDER bind off 3 sts. after Rows 610, 612; 4 sts. after Rows 614, 616, 618, 620, 622, 624.

ON CAM BOX SIDE, bind off 4 sts. after Rows 526, 527; 3 sts. after Rows 528, 529, 530, 531; 2 sts. after Rows 532, 533, 534, 535; 1 st. after Rows 536, 537, 538, 539, 540, 541, 542, 543, then knit to Row 578, bind off the center 12 sts., put the needles on the left side into holding position and complete the right half first.

ON EACH SIDE, increase 1 st. after Rows 432, 444, 456, 468, 480, 492, then knit to Row 494 and work Short Rows for the Bust Darts. ON OPPOSITE SIDE of CAM BOX put into holding position 6 needles after Rows 494, 495, 496, 497, 498, 499, 500, 501, 502, 503, 504, 505, 506, 507. ON OPPOSITE SIDE of CAM BOX bring all needles back into working position after Rows 508, 509, then knit to Row 526.

Continue to decrease 1 st. ON EACH SIDE and 1 st. for EACH DART after Rows 378, 414, then knit to Row 432.

ROWS 353 to 378: Knit even.

Work the front section the same as the back section to ROW 352.

ON CAM BOX SIDE, bind off 3 sts. after Rows 202, 203, 204, 205, 206, 207, 208, 209; 2 sts. after Rows 210, 211, 212, 213, 214, 215; ON EACH SIDE, hang the 1st st. onto the 2nd st. after Rows 216, 218, 220, 222, 224, 226, 228, 230, 232, 234, 236, 238, 240, 242, 244, 246, 248, 250. ON CAM BOX SIDE, bind off 2 sts. after Rows 252, 253, 254, 255; 3 sts. after Rows 256, 257; 4 sts. after Rows 258, 259; 11 sts. after Row 260.

ON EACH SIDE, increase 1 st. after Rows 26, 34, 42, 50, 58, 66, 74, 82, 90, 98, 106, 114, 122, 130, 138, 146, 154, 162, 170, 178, 186, 194, then knit to Row 202.

ROWS 0 to 26: Knit even.

Cast on 61 sts. and work stockinette st.

| | | | |
|-----------------|-------------------------|-------------------------|-------------------------|
| SIZE: | 38 (Chest 37"-38") | 40 (Chest 39"-40") | 42 (Chest 42"-43") |
| YARN: | | | |
| Pullover: | Beatrice Silver Color 1 | Beatrice Silver Color 1 | Amore Color 1 |
| Collar & Cuffs: | Beatrice Color 2 | Beatrice Color 2 | Beatrice Silver Color 2 |
| 50 gr. BALLS: | 9 Color 1 2 Color 2 | 9 Color 1 2 Color 2 | 10 Color 1 2 Color 2 |
| TENSION: | 5 to 7 | 6 to 8 | 8 to 10 |
| GAUGE: | 2" 16 sts. 22 rows | 15 sts. 22 rows | 14 sts. 21 rows |

The instructions are the same for all sizes. PATTERN: Stockinette Stitch with Color 1. COLLAR and CUFFS: K1, P1, Ribbing with Color 2. INCREASES: Move the 2 end sts. 1 needle outward, then place the 3rd st. from the row below onto the empty needle. To form the hem, hang the cast-on sts. back onto the machine behind the latches, then knit the following row with 1 to 2 tension settings higher.

FINISHING: Block all sections. Join front and back section at sides and shoulders. Sew the sleeves together and set in. Join the short ends of collar, then sew 1 edge of collar to inside and 1 edge to outside of neckline.

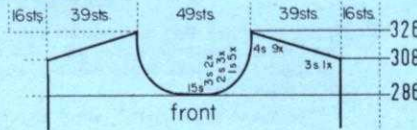

Move the Cam Box to the left side, turn the Row Counter back to 286 and complete the left half. Follow the instructions from*.

*ON CAM BOX SIDE, bind off 3 sts. after Rows 287, 289; 2 sts. after Rows 291, 293, 295; 1 st. after Rows 297, 299, 301, 303, 305. For SHOULDER bind off 3 sts. after Row 308; 4 sts. after Rows 310, 312, 314, 316, 318, 320, 322, 324, 326.

Work the front section the same as the back section to ROW 286, then bind off the center 15 sts., put the needles on the left side into holding position and complete the right half first.

Move the Cam Box to the left side, turn the Row Counter back to 312 and complete the left half. Follow the instructions from*.

*ON CAM BOX SIDE, bind off 4 sts. after Row 312 (EVEN ROWS = SHOULDER SHAPING); 3 sts. after Row 313 (ODD ROWS = NECK SHAPING); 4 sts. after Row 314; 3 sts. after Row 315; 4 sts. after Row 316; 3 sts. after Row 317; 4 sts. after Row 318; 2 sts. after Row 319; 4 sts. after Row 320; 2 sts. after Row 321; 4 sts. after Row 322; 2 sts. after Row 323; 4 sts. after Rows 324, 326.

ON CAM BOX SIDE, bind off 3 sts. after Rows 308, 309; 4 sts. after Rows 310, 311, then knit to Row 312, bind off the center 19 sts., put the needles on the left side into holding position and complete the right half first.

ON CAM BOX SIDE, bind off 4 sts. after Rows 212, 213; 3 sts. after Rows 214, 215; 2 sts. after Rows 216, 217, 218, 219, 220, 221; 1 st. after Rows 222, 223, 224, 225, 226, 227, then knit to Row 308. (For the FRONT Section knit to Row 286).

ROWS 37 to 212: Knit even.

ROWS 0 to 36: Knit even, then form the hem.

Cast on 159 sts. with color 1 and work stockinette st.

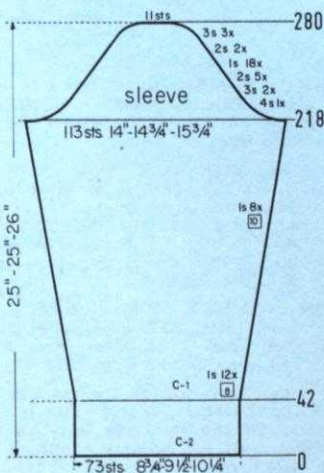
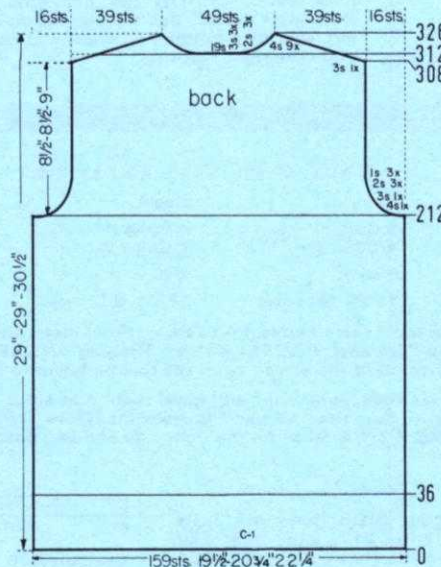

ON CAM BOX SIDE, bind off 4 sts. after Rows 218, 219; 3 sts. after Rows 220, 221, 222, 223; 2 sts. after Rows 224, 225, 226, 227, 228, 229, 230, 231, 232, 233. ON EACH SIDE, hang the 1st st. onto the 2nd st. after Rows 234, 236, 238, 240, 242, 244, 246, 248, 250, 252, 254, 256, 258, 260, 262, 264, 266, 268. ON CAM BOX SIDE, bind off 2 sts. after Rows 270, 271, 272, 273; 3 sts. after Rows 274, 275, 276, 277, 278, 279; 11 sts. after Row 280.

ON EACH SIDE, increase 1 st. after Rows 42, 50, 58, 66, 74, 82, 90, 98, 106, 114, 122, 130, 138, 148, 158, 168, 178, 188, 198, 208, then knit to Row 218.

ROWS 0 to 42: Knit even, then change to stockinette st. and continue with color 1.

Cast on 73 sts. with color 2 and work K1, P1, Ribbing.

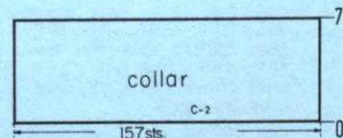

Cast on 157 sts. with color 2 and work 78 rows K1, P1, Ribbing, then bind off all sts.

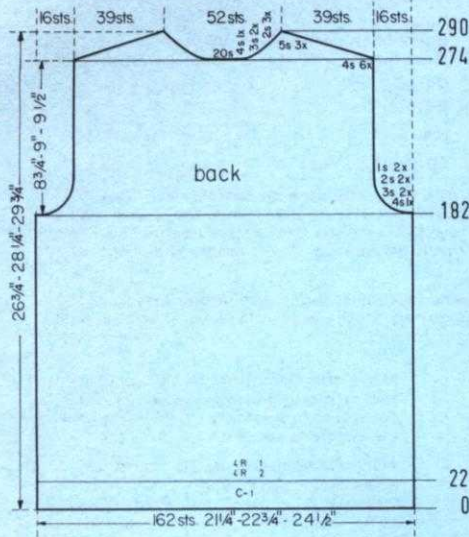

Move the Cam Box to the left side, turn the Row Counter back to 274 and complete the left half. Follow the instructions from*.

* ON CAM BOX SIDE, bind off 4 sts. after Rows 274 (EVEN ROWS = SHOULDER SHAPING), 275 (ODD ROWS = NECK SHAPING), 276; 3 sts. after Row 277; 4 sts. after Row 278; 3 sts. after Row 279; 4 sts. after Row 280; 2 sts. after Row 281; 4 sts. after Row 282; 2 sts. after Row 283; 4 sts. after Row 284; 2 sts. after Row 285; 5 sts. after Rows 286, 288, 290.

ON CAM BOX SIDE, bind off 4 sts. after Rows 182, 183; 3 sts. after Rows 184, 185, 186, 187; 2 sts. after Rows 188, 189, 190, 191; 1 st. after Rows 192, 193, 194, 195, then knit to Row 274, bind off the center 20 sts., put the needles on the left side into holding position and complete the right half first. (For the Front Section knit to ROW 254).

ROWS 23 to 182: Knit even.

ROWS 0 to 22: Knit even, then change to stockinette st. and work the repeated Color Stripes as marked in the Diagram.

Cast on 162 sts. with color 1 and work K1, P1, Ribbing.

Move the Cam Box to the left side, turn the Row Counter back to 254 and complete the left half. Follow the instructions from*.

* ON CAM BOX SIDE, bind off 4 sts. after Row 255; 3 sts. after Rows 257, 259; 2 sts. after Row 261, 263, 265; 1 st. after rows 267, 269, 271, 273. For SHOULDER bind off 4 sts. after Rows 274, 276, 278, 280, 282, 284; 5 sts. after Rows 286, 288, 290.

Work the front section the same as the back section to ROW 254, then bind off the center 12 sts., put the needles on the left side into holding position and complete the right half first.

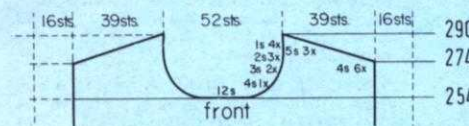

DP 8106



| | | | |
|---------------|------------------------|------------------------|------------------------|
| SIZE: | 8 (Bust 31 1/2"-32") | 12 (Bust 33"-34") | 14 (Bust 35"-36") |
| YARN: | Beatrice | Regia | Regia |
| 50 gr. BALLS: | 5 Color 1 4 Color 2 | 5 Color 1 4 Color 2 | 6 Color 1 4 Color 2 |
| TENSION: | 3 to 5 | 4 to 6 | 5 to 7 |
| GAUGE: | 2" 17 sts. 24 rows | 16 sts. 23 rows | 15 sts. 22 rows |

The instructions are the same for all sizes. PATTERN: Stockinette Stitch and repeated Color Stripes as marked in the Diagrams. EDGES: K1, P1, Ribbing. INCREASES: Move the 2 end sts. 1 needle outward, then place the 3rd st. from the row below onto the empty needle.

FINISHING: Block all sections. Join front and back section at sides and shoulders. Sew the sleeves together and set in. Sew the neckband to neckline. Work 1 row of slip-stitch crochet around the front opening. Work 6 loops on the right side and sew 6 buttons to the left side of the opening. (See picture).

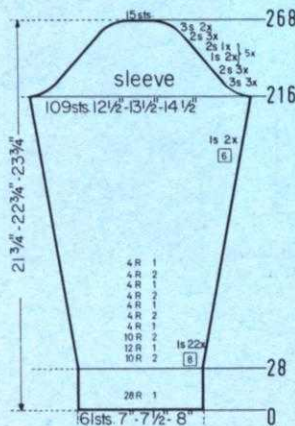

ON CAM BOX SIDE, bind off 3 sts. after Rows 216, 217, 218, 219, 220, 221; 2 sts. after Rows 222, 223, 224, 225, 226, 227; 1 st. after Rows 228, 229, 230, 231; 2 sts. after Rows 232, 233; 1 st. after Rows 234, 235, 236, 237; 2 sts. after Rows 238, 239; 1 st. after Rows 240, 241, 242, 243; 2 sts. after Rows 244, 245; 1 st. after Rows 246, 247, 248, 249; 2 sts. after Rows 250, 251; 1 st. after Rows 252, 253, 254, 255; 2 sts. after Rows 256, 257, 258, 259, 260, 261, 262, 263; 3 sts. after Rows 264, 265, 266, 267; 15 sts. after Row 268.

ON EACH SIDE, increase 1 st. after Rows 28, 36, 44, 52, 60, 68, 76, 84, 92, 100, 108, 116, 124, 132, 140, 148, 156, 164, 172, 180, 188, 196, 204, 210, then knit to Row 216.

ROWS 0 to 28: Knit even, then change to stockinette st. and work the repeated Color Stripes as marked in the Diagram.

Cast on 61 sts. with color 1 and work K1, P1, Ribbing.

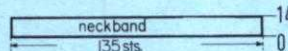

Cast on 135 sts. with color 1 and work 14 rows K1, P1, Ribbing, then bind off all sts.

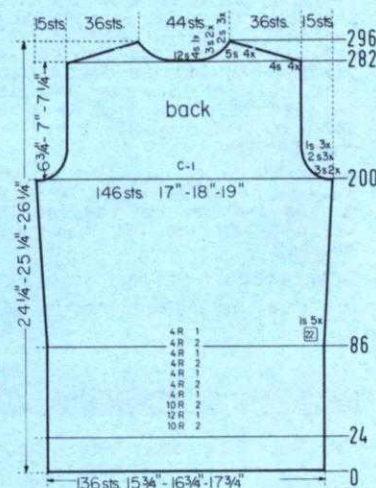
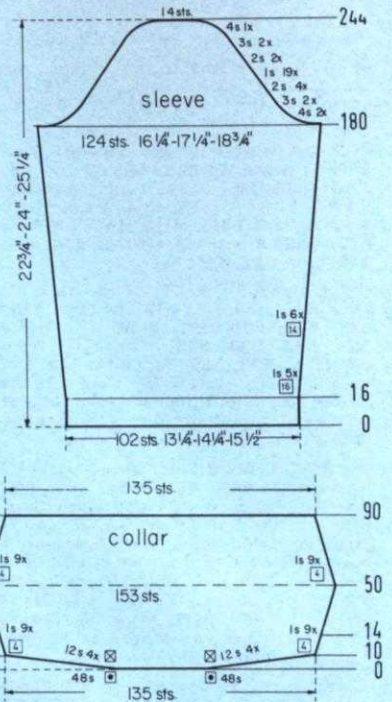
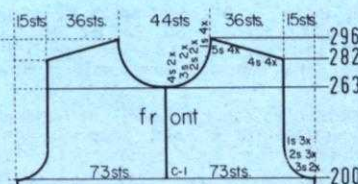

Move the Cam Box to the left side, turn the Row Counter back to 200 and complete the left half. Follow the instructions from*.

ON CAM BOX SIDE, bind off 4 sts. after Rows 263, 265; 3 sts. after Rows 267, 269; 2 sts. after Rows 271, 273; 1 st. after Rows 275, 277, 279, 281. For SHOULDER bind off 4 sts. after Rows 282, 284, 286, 288; 5 sts. after Rows 290, 292, 294, 296.

* ON CAM BOX SIDE, bind off 3 sts. after Rows 200, 202; 2 sts. after Rows 204, 206, 208; 1 st. after Rows 210, 212, 214, then knit to Row 263.

Work the front section the same as the back section to ROW 200, then put 73 needles on the left side into holding position and with color 1 complete the right half first.

HP 3682

| | | | |
|---------------|--------------------|--------------------|--------------------|
| SIZE: | 40 (Chest 39"-40") | 42 (Chest 42"-43") | 46 (Chest 46"-47") |
| YARN: | Allegro Dralon | Allegro Dralon | Dolly Dralon |
| 50 gr. BALLS: | 13 | 14 | 17 |
| TENSION: | 6 to 8 | 7 to 9 | 8 to 10 |
| GAUGE: | 2" 15 sts. 21 rows | 14 sts. 20 rows | 13 sts. 19 rows |



ON CAM BOX SIDE, bind off 4 sts. after Rows 180, 181, 182, 183; 3 sts. after Rows 184, 185, 186, 187; 2 sts. after Rows 188, 189, 190, 191, 192, 193, 194, 195. ON EACH SIDE, hang the 1st st. onto the 2nd st. after Rows 196, 198, 200, 202, 204, 206, 208, 210, 212, 214, 216, 218, 220, 222, 224, 226, 228, 230, 232. ON CAM BOX SIDE, bind off 2 sts. after Rows 234, 235, 236, 237; 3 sts. after Rows 238, 239, 240, 241; 4 sts. after Rows 242, 243; 13 sts. after Row 244.

ON EACH SIDE, increase 1 st. after Rows 16, 32, 48, 64, 80, 96, 110, 124, 138, 152, 166, then knit to Row 180.

ROWS 0 to 16: Knit even.

Cast on 102, sts. and work stockinette st.

Cast on 135 sts., work stockinette st. and Short Rows. ON OPPOSITE SIDE of CAM BOX put into holding position 48 needles after Rows 0, 1. ON OPPOSITE SIDE of CAM BOX bring back into working position 12 needles after Rows 2, 3, 4, 5, 6, 7, 8, 9. ON EACH SIDE, increase 1 st. after Rows 14, 18, 22, 26, 30, 34, 38, 42, 46. ON EACH SIDE, decrease 1 st. after Rows 54, 58, 62, 66, 70, 74, 78, 82, 86. After Row 90 bind off all sts.

Move the Cam Box to the left side, turn the Row Counter back to 282 and complete the left half. Follow the instructions from*.

* ON CAM BOX SIDE, bind off 4 sts. after Rows 282 (EVEN ROWS = SHOULDER SHAPING), 283 (ODD ROWS - NECK SHAPING), 284; 3 sts. after Row 285; 4 sts. after Row 286; 3 sts. after Row 287; 4 sts. after Row 288; 2 sts. after Row 289; 5 sts. after Row 290; 2 sts. after Row 291; 5 sts. after Row 292; 2 sts. after Row 293; 5 sts. after Rows 294, 296.

ON CAM BOX SIDE, bind off 3 sts. after Rows 200, 201, 202, 203; 2 sts. after Rows 204, 205, 206, 207, 208, 209; 1 st. after Rows 210, 211, 212, 213, 214, 215, then knit to Row 282, bind off the center 12 sts., put the needles on the left side into holding position and complete the right half first.

ON EACH SIDE, increase 1 st. after Rows 86, 108, 130, 152, 174, then knit to Row 200 and change to color 1. (Work the Front Section the same to ROW 200).

ROWS 25 to 86: Knit even.

ROWS 0 to 24: Knit even, then change to stockinette st. and work the repeated Color Stripes as marked in the Diagram.

Cast on 136 sts. with color 1 and work K1, P1, Ribbing.

The instructions are the same for all sizes. PATTERN: Stockinette Stitch. INCREASES: Move the 2 end sts. 1 needle outward, then place the 3rd st. from the row below onto the empty needle. DECREASES: Hang the 3rd st. onto the 2nd st., then move the end sts. inward to fill the empty needle. To form the hem, hang the cast-on sts. back onto the machine behind the latches, then knit the following row with 1 to 2 tension setting higher.

FINISHING: Block all sections. Join back and front sections at sides and shoulders. Sew the sleeves together and set in. Gather the lower sleeve edges to the width of the cuffs. Join short ends of cuffs, then sew 1 edge of the cuffs to inside and 1 edge to outside of sleeve edges. Turn under 15 sts. on front edges and hem to wrong side. Fold the collar in half and sew the open side edges together. Sew 1 edge of collar to inside and 1 edge to outside of neckline, leaving 1" on each front edge free. Turn under 34 rows on upper edges of the pockets and sew the open side edges together. Fold over 2" on upper pocket edges and hold in place with 2 buttons. Sew the pockets in place. (See picture). Finish the buttonholes, sew on buttons.

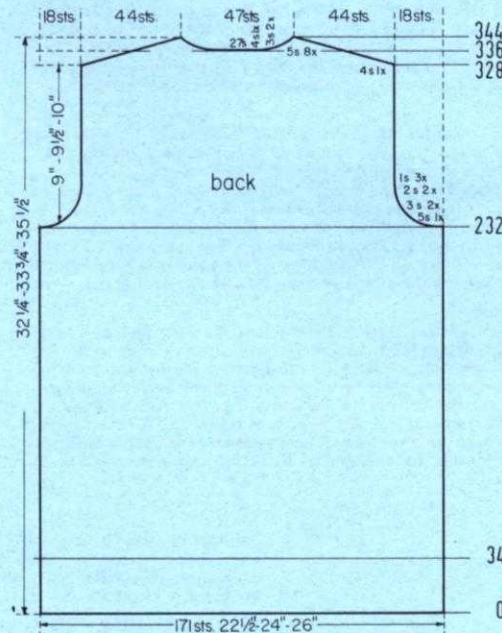

Move the Cam Box to the left side, turn the Row Counter back to 336 and complete the left half. Follow the instructions from*.

* ON CAM BOX SIDE, bind off 5 sts. after Row 336 (EVEN ROWS = SHOULDER SHAPING); 4 sts. after Row 337 (ODD ROWS = NECK SHAPING); 5 sts. after Row 338; 3 sts. after Row 339; 5 sts. after Row 340; 3 sts. after Row 341; 5 sts. after Rows 342, 344.

ON CAM BOX SIDE, bind off 4 sts., after Rows 328, 329; 5 sts. after Rows 330, 331, 332, 333, 334, 335, then knit to Row 336, bind off the center 27 sts., put the needles on the left side into holding position and complete the right half first.

ON CAM BOX SIDE, bind off 5 sts. after Rows 232, 233; 3 sts. after Rows 234, 235, 236, 237; 2 sts. after Rows 238, 239, 240, 241; 1 st. after Rows 242, 243, 244, 245, 246, 247, then knit to Row 328.

ROWS 35 to 232: Knit even.

ROWS 0 to 34: Knit even, then form the hem.

Cast on 171 sts. and work stockinette st.

ON CAM BOX SIDE, bind off 3 sts. after Rows 200, 201, 202, 203; 2 sts. after Rows 204, 205, 206, 207, 208, 209; 1 st. after Rows 210, 211, 212, 213, 214, 215, then knit to Row 282, bind off the center 12 sts., put the needles on the left side into holding position and complete the right half first.

ON EACH SIDE, increase 1 st. after Rows 86, 108, 130, 152, 174, then knit to Row 200 and change to color 1. (Work the Front Section the same to ROW 200).

ROWS 25 to 86: Knit even.

ROWS 0 to 24: Knit even, then change to stockinette st. and work the repeated Color Stripes as marked in the Diagram.

Cast on 136 sts. with color 1 and work K1, P1, Ribbing.

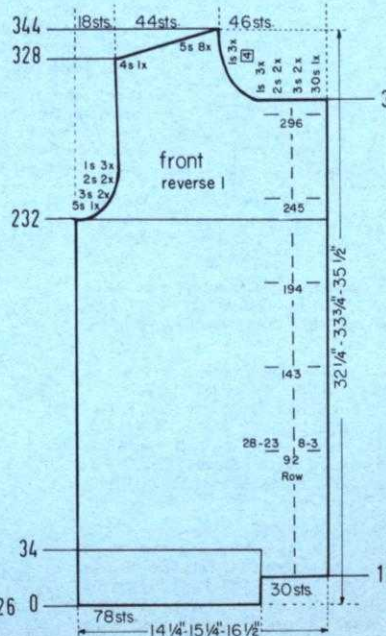

Work the second front section with reverse shapings, casting on from left to right. (Cam Box will be on the RIGHT side at Row 0). Omit the buttonholes.

ON CAM BOX SIDE, bind off 30 sts. after Row 303; 3 sts. after Rows 305, 307; 2 sts. after Rows 309, 311; 1 st. after Rows 313, 315, 317, 319, 323, 327. For SHOULDER bind off 4 sts. after Row 328; 5 sts. after Rows 330, 332, 334, 336, 338, 340, 342, 344.

Make buttonholes after Rows in (). ON CAM BOX SIDE, bind off 5 sts. after Row 232; 3 sts. after Rows 234, 236; 2 sts. after Rows 238, 240; 1 st. after Rows 242, 244, (245), 246, (296), then knit to Row 303.

ROWS 35 to 232: Make buttonholes after Rows 92, 143, 194, over the 3rd-8th and 23rd-28th sts. counting from the right side, then knit to Row 232.

ROWS 18 to 34: Knit even, then form the hem. (First 78 cast-on sts.).

ROWS 0 to 17: Knit even, then cast on 30 sts. ON CAM BOX SIDE.

From right to left, cast on 78 sts. and work stockinette st. (Cam Box will be on the LEFT side at Row 0).

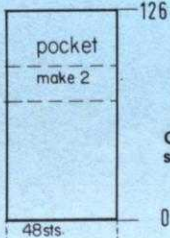

Cast on 48 sts. and work 126 rows stockinette st., then bind off all sts.

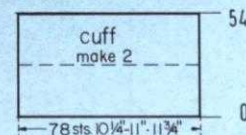

Cast on 78 sts. and work 54 rows stockinette st., then bind off all sts.

KK 5387

| | | | |
|--------------------|--------------------------------------|--|--|
| SIZE: | 6 (Chest 23"-24") | 8 (Chest 25"-26") | 10 (Chest 27"-28") |
| YARN: | | | |
| JACKET: | Alanda (Color 1) | Cara Tweed (Color 1) | Cara Tweed (Color 1) |
| 50 gr. BALLS: | 5 balls Regia (Color 2) 1 ball | 6 balls Allegro (Color 2) 1 ball | 7 balls Allegro (Color 2) 1 ball |
| PANTS & PULLOVER: | Regia (Color 3) 9 balls | Allegro (Color 3) 10 balls | Allegro (Color 3) 11 balls |
| TENSION: | | | |
| Color 1 | 8 to 10 | 9 to 10 | 10 |
| Colors 2 & 3 | 4 to 6 | 6 to 8 | 7 to 9 |
| GAUGE: | 2" | | |
| Color 1 | 14 sts. 18 rows | 13 sts. 17 rows | 12 sts. 16 rows |
| Colors 2 & 3 | 16 sts. 23 rows | 15 sts. 21 rows | 14 sts. 20 rows |
| Jacket Type Zipper | 11" | 12" | 13" |

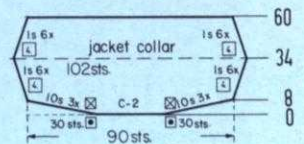

The instructions are the same for all sizes. **PATTERN:** Stockinette Stitch. **PULLOVER EDGES:** K1, P1, Ribbing. **INCREASES:** Move the 2 end sts. 1 needle outward, then place the 3rd st. from the row below onto the empty needle. **DECREASES:** Hang the 3rd st. onto the 2nd st., then move the end sts. inward to fill the empty needle. Begin the Darts by hanging the sts. together as marked in the Diagram, then move the sts. together to fill the empty needles. The following decreases then increases for the Dart lie directly above. To form the hems, hang the cast-on sts. back onto the machine behind the latches, then change to the proper tension for the heavier yarn.

FINISHING: Block all sections. **JACKET:** Turn under the 4 sts. on the front edge of section 4 and hem. Open the zipper, then sew one edge to the hemmed front edge, leaving 2 1/2" (2 3/4"-3") on the upper edge free. Fold section 3 in half lengthwise. Pin the marked No. 3 edge to the marked No. 4 edge with No. 3 edge UNDER No. 4 approximately 3/4", then sew in place. Join the front sections to the back section at sides and shoulders. Sew the other half of zipper on the wrong side down the front of section 1. With wrong sides together, sew section 2 to section 1. Close opening at lower edge of band. Sew Sleeves together and set in. Fold collar in half and sew the open side edges together. Sew 1 edge of collar to inside and 1 edge to outside of neckline, leaving about 4" on each side of front free. Sew snaps and buttons to flap, (see picture).

PANTS: Sew the inner leg seams together, then turn under 13 rows on lower edges and hem to wrong side. Join front and back section at center back and center front, leaving 5" on center front free for the zipper. Turn under a small amount around the opening and hem to wrong side. Turn under 13 rows on upper edge and hem to wrong side, then insert an elastic band. Sew the band to the front edges. Sew the zipper in the opening. **PULLOVER:** Join front and back section at sides and shoulders, leaving the left shoulder open 2 1/2". Turn under a small amount around the opening and hem to wrong side. Sew the sleeves together and set in. Sew 1 edge of the collar to inside and 1 edge to outside of neckline. Sew the zipper in place.

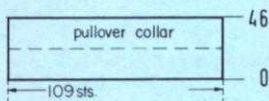
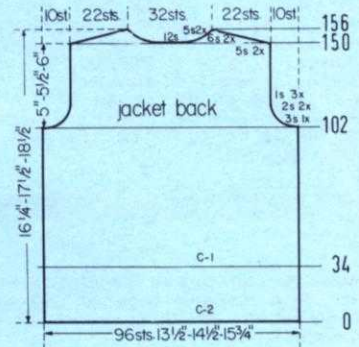

Cast on 109 sts. and work 46 rows K1, P1, Ribbing, then bind off all sts.

Move the Cam Box to the left side, turn the Row Counter back to 162 and complete the left half. Follow the instructions from*.

*ON CAM BOX SIDE, bind off 3 sts. after Row 163; 2 sts. after Rows 165, 167, 169; 1 st. after Rows 171, 173, 175. For SHOULDER bind off 4 sts. after Row 182; 5 sts. after Rows 184, 186, 188, 190.

Work the front section the same as the back section to ROW 162, then bind off the center 11 sts., put the needles on the left side into holding position and complete the right half first.

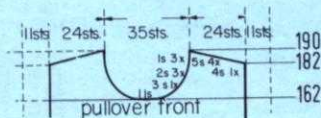
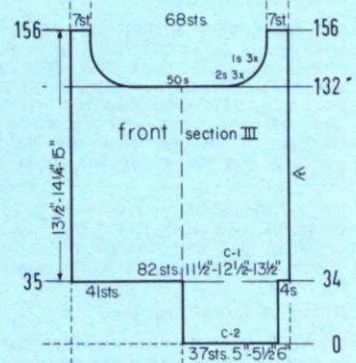

Move the Cam Box to the left side, turn the Row Counter back to 182 and complete the left half. Follow the instructions from*.

*ON CAM BOX SIDE, bind off 4 sts. after Row 182 (EVEN ROWS = SHOULDER SHAPING); 3 sts. after Row 183 (ODD ROWS = NECK SHAPING); 5 sts. after Row 184; 3 sts. after Row 185; 5 sts. after Row 186; 2 sts. after Row 187; 5 sts. after Row 188; 2 sts. after Row 189; 5 sts. after Row 190.

ON CAM BOX SIDE, bind off 4 sts. after Rows 128, 129; 2 sts. after Rows 130, 131, 132, 133; 1 st. after Rows 134, 135, 136, 137, 138, 139, then knit to Row 182, bind off the center 15 sts., put the needles on the left side into holding position and complete the right half first. (For the FRONT Section knit to ROW 162).

ROWS 27 to 128: Knit even.

ROWS 0 to 26: Knit even, then change to stockinette st.

Cast on 105 sts. and work K1, P1, Ribbing.

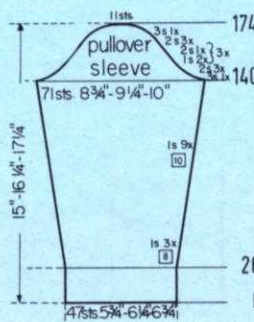
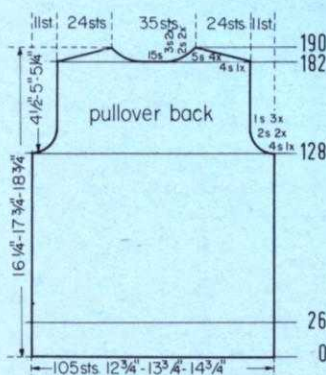

ON CAM BOX SIDE, bind off 3 sts. after Rows 140, 141; 2 sts. after Rows 142, 143, 144, 145, 146, 147; 1 st. after Rows 148, 149, 150, 151; 2 sts. after Rows 152, 153; 1 st. after Rows 154, 155, 156, 157; 2 sts. after Rows 158, 159; 1 st. after Rows 160, 161, 162, 163; 2 sts. after Rows 164, 165, 166, 167, 168, 169, 170, 171; 3 sts. after Rows 172, 173, 174.

ON EACH SIDE, increase 1 st. after Rows 26, 34, 42, 50, 60, 70, 80, 90, 100, 110, 120, 130, then knit to Row 140.

ROWS 0 to 26: Knit even, then change to stockinette st.

Cast on 47 sts. and work K1, P1, Ribbing.

Cast on 90 sts. with Color 2, work stockinette st. and Short Rows. ON OPPOSITE SIDE of CAM BOX, put into holding position 30 needles after Rows 0, 1. ON OPPOSITE SIDE of CAM BOX bring back into working position 10 needles after Rows 2, 3, 4, 5, 6, 7. ON EACH SIDE, increase 1 st. after Rows 12, 16, 20, 24, 28, 32. ON EACH SIDE, decrease 1 st. after Rows 36, 40, 44, 48, 52, 56. After Row 60 bind off all 90 sts.

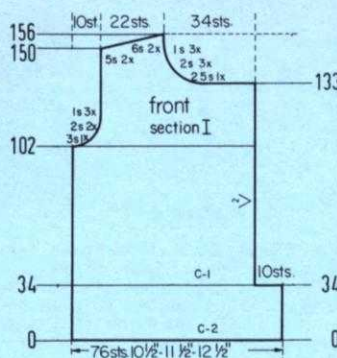

ON CAM BOX SIDE, bind off 25 sts. after Row 133; 2 sts. after Rows 135, 137, 139; 1 st. after Rows 141, 143, 145. For SHOULDER bind off 5 sts. after Rows 150, 152; 6 sts. after Rows 154, 156.

ON CAM BOX SIDE, bind off 3 sts. after Row 102; 2 sts. after Rows 104, 106; 1 st. after Rows 108, 110, 112, then knit to Row 133.

ROWS 35 to 102: Knit even.

ROWS 0 to 34: Knit even, then bind off 10 sts. ON OPPOSITE SIDE of CAM BOX. (Use a separate length of yarn). Now form the hem, change to Color 1 and turn the tension to the proper number.

From right to left, cast on 76 sts. with color 2 and work stockinette st. (Cam Box will be on the LEFT side at Row 0).

Move the Cam Box to the left side, turn the Row Counter back to 150 and complete the left half. Follow the instructions from*.

*ON CAM BOX SIDE, bind off 5 sts. after Rows 150 (EVEN ROWS = SHOULDER SHAPING), 151 (ODD ROWS = NECK SHAPING), 152, 153; 6 sts. after Rows 154, 156.

ON CAM BOX SIDE, bind off 3 sts. after Rows 102, 103; 2 sts. after Rows 104, 105, 106, 107; 1 st. after Rows 108, 109, 110, 111, 112, 113, then knit to Row 150, bind off the center 12 sts., put the needles on the left side into holding position and complete the right half first.

ROWS 35 to 102: Knit even.

ROWS 0 to 34: Knit even, then form the hem, change to Color 1 and turn the tension to the proper number.

Cast on 96 sts. with color 2 and work stockinette st.

Move the Cam Box to the left side, turn the Row Counter back to 132 and complete the left half. Follow the instructions from*.

*ON CAM BOX SIDE, bind off 2 sts. after Rows 133, 135, 137; 1 st. after Rows 139, 141, 143. After Row 156 bind off the remaining 7 sts.

ROWS 36 to 132: Knit even, then bind off the center 50 sts., put the needles on the left side into holding position and complete the right half first.

ROWS 0 to 35: Knit even to Row 34, then form the hem, change to Color 1, turn the tension to the proper number and cast on 4 sts. ON CAM BOX SIDE. Now knit to Row 35, then cast on 41 sts. ON CAM BOX SIDE, and work over 82 needles.

Cast on 37 sts. with color 2 and work stockinette st.

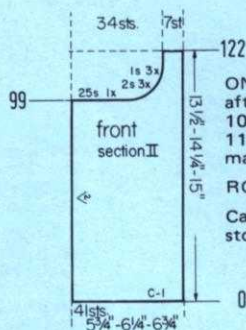

ON CAM BOX SIDE, bind off 25 sts. after Row 99; 2 sts. after Rows 101, 103, 105; 1 st. after Rows 107, 109, 111. After Row 122 bind off the remaining 7 sts.

ROWS 0 to 99: Knit even.

Cast on 41 sts. with Color 1 and work stockinette st.

Work the second pants section with reverse shapings, casting on from right to left. (Cam Box will be on the LEFT side at Row 0.)

Decrease 1 st. ON CAM BOX SIDE and 2 sts. for the DART after Rows 266, 278, 290, 302, but do not knit after the last decreases. Work Short Rows. ON OPPOSITE SIDE of CAM BOX put into holding position 37 needles after Rows 302; 13 needles after Rows 304, 306, 308. After Row 310 bring all needles back into working position, then knit to Row 336 and bind off all 89 sts.

ON CAM BOX SIDE, bind off 3 sts. after Row 222 (EVEN ROWS = CENTER BACK); 2 sts. after Row 223 (ODD ROWS = CENTER FRONT); 3 sts. after Row 224; 2 sts. after Rows 225, 226, 227, 228; 1 st. after Rows 229, 230, 231, 232, 233, 234, 235, 236, 237, 238, 239, 240, 242, 246, 250, 254, then knit to Row 266.

Increase 2 sts. for the Dart after (DART). ON OPPOSITE SIDE of CAM BOX increase 1 st. after Rows in (). ON CAM BOX SIDE, increase 1 st. after Rows 130, (130), (DART 130), 136, (138), 142, (146), 148, 154, (154), 160, (162), 166, (DART 168), (170), 172, 178, (178), 184, (186), 190, (194), 196, 202, (202), (DART 206), 208, (210), 214, (216), then knit to Row 222.

Decrease 1 st. ON EACH SIDE and 2 sts. for the DART after Rows 34, 72, 110, then knit to Row 130.

ROWS 0 to 34: Knit even.

Cast on 112 sts. and work stockinette st.

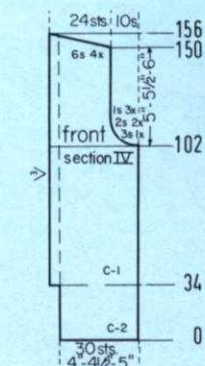
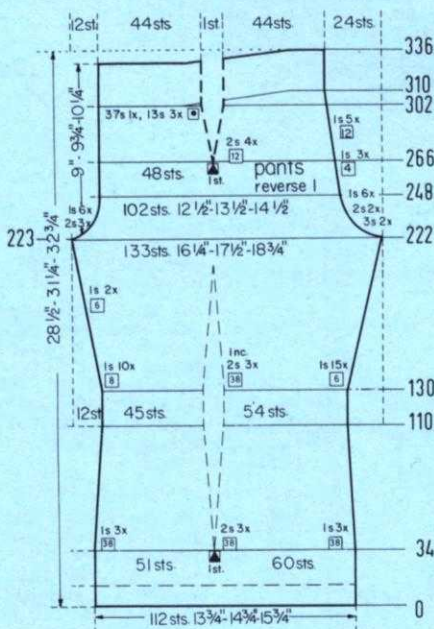

ON CAM BOX SIDE, bind off 3 sts. after Row 102; 2 sts. after Rows 104, 106; 1 st. after Rows 108, 110, 112, then knit to Row 150. For SHOULDER bind off 6 sts. after Rows 150, 152, 154, 156.

ROWS 35 to 102: Knit even.

ROWS 0 to 34: Knit even, then form the hem, change to Color 1, turn the tension to the proper number and cast on 4 sts. ON OPPOSITE SIDE of CAM BOX. (Use a separate length of yarn).

Cast on 30 sts. with Color 2 and work stockinette st.

ON CAM BOX SIDE, bind off 3 sts. after Rows 132, 133, 134, 135; 2 sts. after Rows 136, 137, 138, 139, 140, 141; 1 st. after Rows 142, 143; 2 sts. after Rows 144, 145; 1 st. after Rows 146, 147; 2 sts. after Rows 148, 149; 1 st. after Rows 150, 151; 2 sts. after Rows 152, 153; 1 st. after Rows 154, 155; 2 sts. after Rows 156, 157, 158, 159; 4 sts. after Rows 160, 161; 10 sts. after Row 162.

ON EACH SIDE, increase 1 st. after Rows 34, 44, 54, 64, 74, 84, 94, 104, 114, 124, then knit to Row 132.

ROWS 0 to 34: Knit even, then form the hem, change to Color 1 and turn the tension to the proper number.

Cast on 50 sts. with Color 2 and work stockinette st.



MK 5388

| | | |
|---------------|--|--|
| SIZE: | 8 (Chest 27"-28") | 10 (Chest 28½"-30") |
| YARN: | Allegro Dralon | Dolly Dralon Crepe |
| 50 gr. BALLS: | | |
| Jacket: | 3 Color 1 3 Color 2 1 Color 3 3 Color 4 | 4 Color 1 4 Color 2 1 Color 3 4 Color 4 |
| Pants: | 6 Color 1 5 Color 3 | 7 Color 1 6 Color 3 |
| TENSION: | 5 to 7 | 7 to 9 |
| GAUGE: | 2" 15 sts. 21 rows | 14 sts. 20 rows |



The instructions are the same for all sizes. PATTERN: Stockinette Stitch. Pullover EDGES: K1, P1, Ribbing. The JACKET is knitted sideways and has Color Stripes as marked in the Diagrams. INCREASES: Move the 2 end sts. 1 needle outward, then place the 3rd st. from the row below onto the empty needle. DECREASES: Hang the 3rd st. onto the 2nd st., then move the end sts. inward to fill the empty needles. Begin the Pants Darts by hanging the sts. together as marked in the Diagram, then move the sts. together to fill the empty needles. The following decreases, then increases for the Darts lie directly above.

FINISHING: Block all sections. JACKET: Join back and front sections at sides and shoulders. Sew the sleeves together and set in. Turn under 12 sts. on sleeve edges, 12 sts. on lower edge and hem to wrong side. Turn under the facing on front edges and hem in place. Turn under 9 sts. on upper edges of the pockets, hem to wrong side, then sew the pockets in place. Fold the collar in half and sew the open side edges together. Sew 1 edge of the collar to inside and 1 edge to outside of neckline, leaving about 1" to 1½" free on the front edges. Finish the buttonholes, sew on buttons. PANTS: Sew the inner leg seams together, then turn under 13 rows on lower edges and hem to wrong side. Join pants at center back and center front. Turn under 13 rows on upper edge and hem to wrong side. Insert an elastic band into upper hem. PULLOVER: Join front and back section at sides and shoulders. Sew the sleeves together and set in. Sew the neckband to neckline. Work 1 row of single crochet around the back opening, then sew in a zipper.

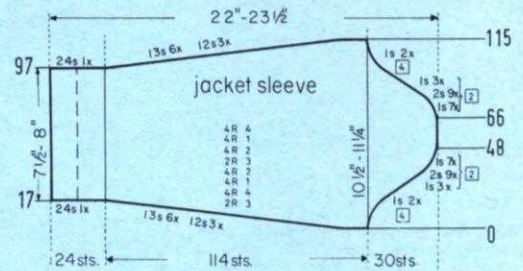

Move the Cam Box to the left side, turn the Row Counter back to 178 and complete the left half. Follow the instructions from*.

*ON CAM BOX SIDE, bind off 3 sts. after Row 179; 2 sts. after Rows 181, 183, 185; 1 st. after Rows 187, 189, 191. For SHOULDER bind off 5 sts. after Rows 196, 198, 200, 202; 6 sts. after Row 204.

ROWS 163 to 178: Knit even, then bind off the center 12 sts., put the needles on the left side into holding position and complete the right half first.

Work the front section the same as the back section to ROW 162.

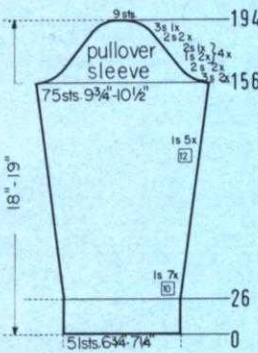

ON CAM BOX SIDE, bind off 3 sts. after Rows 156, 157, 158, 159; 2 sts. after Rows 160, 161, 162, 163; 1 st. after Rows 164, 165, 166, 167; 2 sts. after Rows 168, 169; 1 st. after Rows 170, 171, 172, 173; 2 sts. after Rows 174, 175; 1 st. after Rows 176, 177, 178, 179; 2 sts. after Rows 180, 181; 1 st. after Rows 182, 183, 184, 185; 2 sts. after Rows 186, 187, 188, 189, 190, 191; 3 sts. after Rows 192, 193; 9 sts. after Row 194.

ON EACH SIDE, increase 1 st. after Rows 26, 36, 46, 56, 66, 76, 86, 96, 108, 120, 132, 144, then knit to Row 156.

ROWS 0 to 26: Knit even, then change to stockinette st.

Cast on 51 sts. with color 3 and work K1, P1, Ribbing.

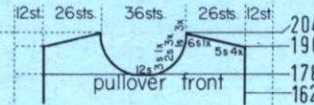

Move the Cam Box to the left side, turn the Row Counter back to 162 and complete the left half. Follow the instructions from*.

ON CAM BOX SIDE, bind off 8 sts. after Row 195 (ODD ROWS = NECK SHAPING); 5 sts. after Row 196 (EVEN ROWS = SHOULDER SHAPING); 3 sts. after Row 197; 5 sts. after Row 198; 3 sts. after Row 199; 5 sts. after Row 200; 2 sts. after Row 201; 5 sts. after Row 202; 2 sts. after Row 203; 6 sts. after Row 204.

*ROWS 163 to 195: Knit even.

ON CAM BOX SIDE, bind off 4 sts. after Rows 136, 137; 2 sts. after Rows 138, 139, 140, 141; 1 st. after Rows 142, 143, 144, 145, 146, 147, 148, 149, then knit to Row 162, put 44 needles on the left side into holding position and complete the right half first.

ROWS 27 to 136: Knit even.

ROWS 0 to 26: Knit even, then change to stockinette st.

Cast on 112 sts. with color 3 and work K1, P1, Ribbing.

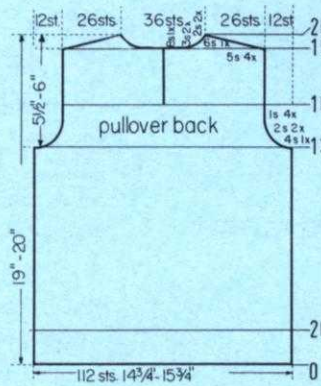

Cast on 113 sts. with color 3 and work 16 rows K1, P1, Ribbing, then bind off all sts.

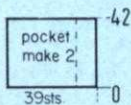
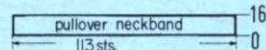

Cast on 39 sts. with color 4, work stockinette st. and the color stripes as marked in the Diagram of the back section. After Row 42 bind off all sts.

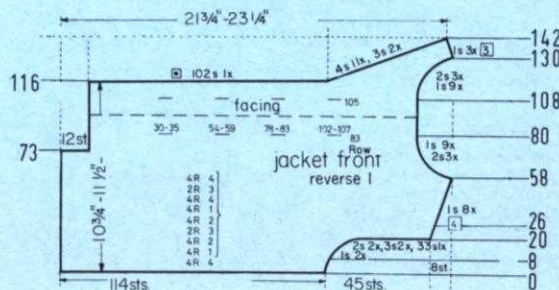

Work the second front section with reverse shapings, casting on from right to left, and begin with the 10th needle on the far right end. (Cam Box will be on the LEFT side at Row 0). Omit the buttonholes.

ON CAM BOX SIDE, (Neck Edge) cast on 1 st. after Rows 108, 110, 112, 114, then again after Rows in (). Knit Short Rows for the FRONT SHAPING. ON OPPOSITE SIDE OF CAM BOX put into holding position 102 needles after Row 116; (116), 4 needles after Rows 118, (118), 120, (120), 122, (122), 124, (124), 126. ON CAM BOX SIDE, cast on 2 sts. after Row 126, then again after Rows in (). Continue to put into holding position 4 needles after Rows 128, (128), 130, (130), 132. ON SHOULDER SIDE, bind off 1 st. after Row 133, then again after Rows in (). Continue to put into holding position 4 needles after Rows 134, 136, (136), 138; (139), 3 needles after Row 140. (3 needles remain). After Row 142 bring all needles back into working position and bind off all 152 sts.

ON CAM BOX SIDE, bind off 2 sts. after Rows 58, 60, 62; 1 st. after Rows 64, 66, 68, 70, 72; 12 sts. after Row 73 (Hem Edge); 1 st. after Rows 74, 76, 78, 80. Make buttonholes after Row 83 over the 30th-35th, 54th-59th, 78th-83rd, 102nd-107th sts. counting from the left side. Knit to Row 105 and make buttonholes over the same sts. as before, then knit to Row 108.

ON CAM BOX SIDE, cast on 1 st. after Rows 26, 30, 34, 38, 42, 46, 50, 54, then knit to Row 58.

ON CAM BOX SIDE, cast on 1 st. after Rows 8, 10; 2 sts. after Rows 12, 14; 3 sts. after Rows 16, 18; 33 sts. after Row 20.

ROWS 0 to 8: Knit even.

Cast on 114 sts. with color 4, work stockinette st. and the repeated color stripes as marked in the Diagram. (167 needles will be used. Cast on starting with the 10th needle on the far left end.)

ON CAM BOX SIDE, bind off 1 st. after Rows 66, 68, 70, 72, 74, 76, 78; 2 sts. after Rows 80, 82, 84, 86, 88, 90, 92, 94, 96; 24 sts. after Row 97; 1 st. after Row 98; 13 sts. after Row 99; 1 st. after Row 100; 13 sts. after Row 101; 1 st. after Row 102; 13 sts. after Rows 103, 105; 1 st. after Row 106; 13 sts. after Rows 107, 109; 1 st. after Row 110; 12 sts. after Rows 111, 113, 115.

ON CAM BOX SIDE, cast on 12 sts. after Rows 1, 3 (ODD ROWS = LENGTH); 1 st. after Row 4 (EVEN ROWS = CAP); 13 sts. after Rows 5, 7; 1 st. after Row 8; 13 sts. after Rows 9, 11; 1 st. after Row 12; 13 sts. after Row 13; 1 st. after Row 14; 13 sts. after Row 15; 1 st. after Row 16; 24 sts. after Row 17; 2 sts. after Rows 18, 20, 22, 24, 26, 28, 30, 32, 34; 1 st. after Rows 36, 38, 40, 42, 44, 46, 48, then knit to Row 66.

Cast on 12 sts. with color 3, work stockinette st. and the color stripes as marked in the Diagram.

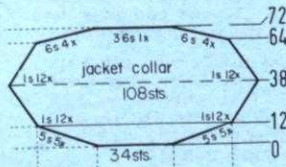

Cast on 34 sts. with color 4, work stockinette st. and the repeated color stripes as marked in the Diagram of the Back Section. ON CAM BOX SIDE, cast on 5 sts. after Rows 2, 3, 4, 5, 6, 7, 8, 9, 10, 11. ON EACH SIDE, increase 1 st. after Rows 14, 16, 18, 20, 22, 24, 26, 28, 30, 32, 34, 36. ON EACH SIDE, decrease 1 st. after Rows 40, 42, 44, 46, 48, 50, 52, 54, 56, 58, 60, 62. ON CAM BOX SIDE, bind off 6 sts. after Rows 64, 65, 66, 67, 68, 69, 70, 71; 36 sts. after Row 72.

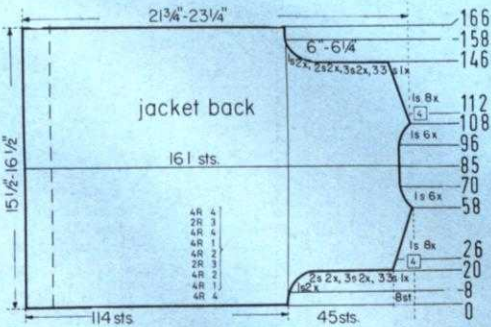

ON CAM BOX SIDE, bind off 33 sts. after Row 146; 3 sts. after Rows 148, 150; 2 sts. after Rows 152, 154; 1 st. after Rows 156, 158, then knit to Row 166 and bind off the remaining 114 sts.

ON CAM BOX SIDE, bind off 1 st. after Rows 112, 116, 120, 124, 128, 132, 136, 140, then knit to Row 146.

ON CAM BOX SIDE, cast on 1 st. after Rows 96, 98, 100, 102, 104, 106, then knit to Row 112.

ON CAM BOX SIDE, bind off 1 st. after Rows 58, 60, 62, 64, 66, 68, then knit to Row 96.

ON CAM BOX SIDE, cast on 1 st. after Rows 26, 30, 34, 38, 42, 46, 50, 54, then knit to Row 58.

ON CAM BOX SIDE, cast on 1 st. after Rows 8, 10; 2 sts. after Rows 12, 14; 3 sts. after Rows 16, 18; 33 sts. after Row 20, then knit to Row 26.

ROWS 0 to 8: Knit even.

Cast on 114 sts. with color 4, work stockinette st. and the repeated color stripes as marked in the Diagram.

Work the second section with reverse shapings, casting on from right to left. (Cam Box will be on the LEFT side at Row 0).

Decrease 1 st. ON CAM BOX SIDE and 2 sts. for the DART after Rows 298, 310, 322, 334, but do not knit after the last decreases. Work Short Rows. ON OPPOSITE SIDE of CAM BOX put into holding position 40 needles after Row 334; 13 needles after Rows 336, 338, 340. After Row 342 bring all needles back into working position, then knit to Row 368 and bind off the remaining 95 sts.

ON CAM BOX SIDE, bind off 3 sts. after Row 248 (EVEN ROWS = CENTER BACK SHAPING); 2 sts. after Row 249 (ODD ROWS = CENTER FRONT SHAPING); 3 sts. after Row 250; 2 sts. after Rows 251, 253, 254; 1 st. after Row 255; 2 sts. after Row 256; 1 st. after Rows 257, 258, 259, 260, 261, 262, 263, 264, 265, 266, 270, 274, 286, then knit to Row 298.

Increase 2 sts. for the DART after (DART). ON OPPOSITE SIDE of CAM BOX increase 1 st. after Rows in (). ON CAM BOX SIDE, increase 1 st. after Rows 142, (142), (DART 142), 150, (152), 158, (162), 166, (172), 174, 182, (182), (DART 186), 190, (192), 198, (200), 206, (208), 212, (216), 218, 224, (224), 230, (DART 230), (232), 236, (240), 242, then knit to Row 248.

Decrease 1 st. ON EACH SIDE and 2 sts. for the DART after Rows 34, 78, 122, then knit to Row 142.

ROWS 0 to 34: Knit even.

Cast on 118 sts. with color 1 and work stockinette st.

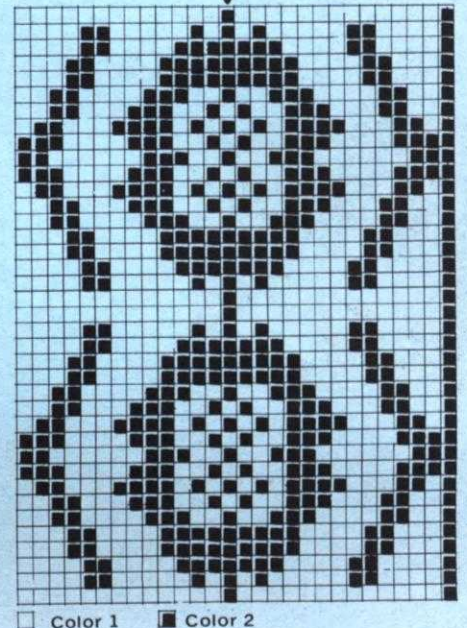
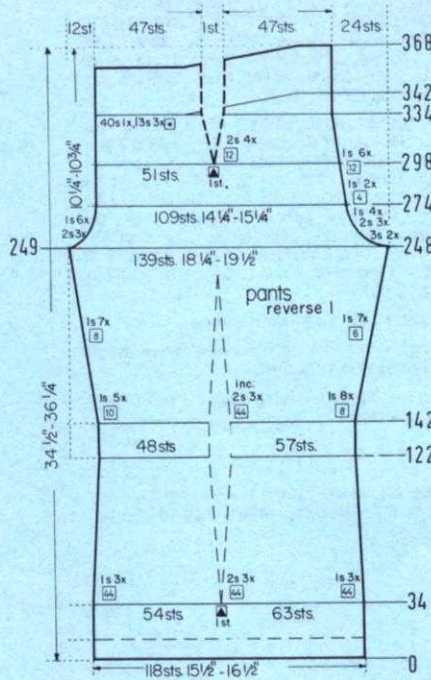

DP 8110

| | | |
|---------------|--|------------------------------------|
| SIZE: | 12 (Bust 34"-35") | 16 (Bust 37"-38") |
| YARN: | Allegro Darlon | Flamingo Dralon |
| 50 gr. BALLS: | 6 Color 1 4 Color 2 | 7 Color 1 4 Color 2 |
| TENSION: | 7 to 9 | 7 to 9 |
| GAUGE: | 2" Stk. 15 sts. 20 rows Pattern 13 sts. 18 rows | 14 sts. 20 rows 12 sts. 18 rows |

The instructions are the same for both sizes. PATTERN: Front and Back Section: Norwegian Design according to Line Drawing or use JAC 40 and Pattern No. 460. Each row in the Norwegian Design is counted as 1 row in the Gauge and Instructions, but several movements of the Cam Box are needed to complete 1 row. Sleeves: Stockinette Stitch. Cuffs and Collar: K1, P1, Ribbing. INCREASES: Move the 2 end sts. 1 needle outward, then place the 3rd st. from the row below onto the empty needle.

FINISHING: Block all sections. Join front and back section at sides and shoulders. Sew the sleeves together and set in. Join the short ends of collar, then sew collar to neckline and fold over to outside. Turn under 16 rows on lower edge and hem to wrong side.

Continued on page 18

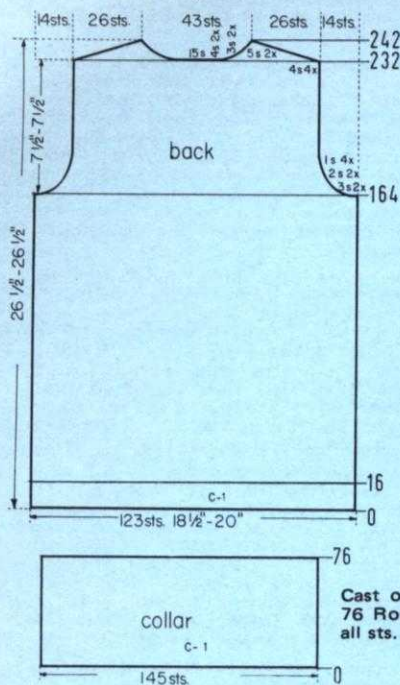

Bring the needles on the left side into working position, knit 1 row in PATTERN to the left side, turn the Row Counter back to 232 and complete the left half. Follow the instructions from*.

*ON CAM BOX SIDE, bind off 4 sts. after Rows 232 (EVEN ROWS = SHOULDER SHAPING), 233 (ODD ROWS = NECK SHAPING), 234, 235, 236; 3 sts. after Row 237; 4 sts. after Row 238; 3 sts. after Row 239; 5 sts. after Rows 240, 242.

ON CAM BOX SIDE, bind off 3 sts. after Rows 164, 165, 166, 167; 2 sts. after Rows 168, 169, 170, 171; 1 st. after Rows 172, 173, 174, 175, 176, 177, 178, 179, then knit to Row 232, bind off the center 15 sts., put the needles on the left side into holding position and complete the right half first. (For the Front Section knit to ROW 210).

ROWS 17 to 164: Knit even.

ROWS 0 to 16: Knit even, then begin the Norwegian Design.

Cast on 123 sts. with color 1 and work stockinette st.

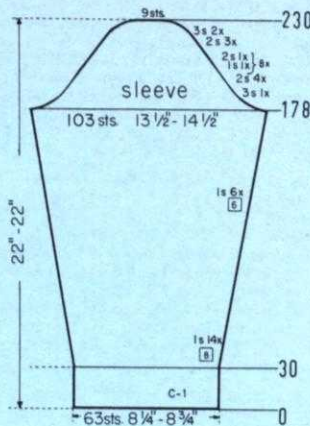

Bring the needles on the left side into working position, knit 1 row in PATTERN to the left side, turn the Row Counter back to 210 and complete the left half. Follow the instructions from*.

* ON CAM BOX SIDE, bind off 3 sts. after Rows 211, 213; 2 sts. after Rows 215, 217, 219; 1 st. after Rows 221, 223, 225, 227, 229. For SHOULDER bind off 4 sts. after Rows 232, 234, 236, 238; 5 sts. after Rows 240, 242.

Work the front section the same as the back section to ROW 210, then bind off the center 13 sts., put the needles on the left side into holding position and complete the right half first.

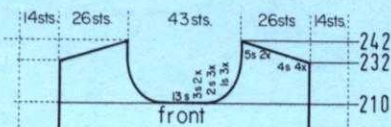

DK 8005

| SIZE: | 10 (Bust 32"-33") | 12 (Bust 34"-35") | 16 (Bust 38"-39") |
|---------------|-------------------------|-------------------------|-------------------------|
| YARN: | Subita Crepe 2 x 3 | Regia | Amore |
| 50 gr. BALLS: | 12 Color 1 3 Color 2 | 13 Color 1 3 Color 2 | 16 Color 1 4 Color 2 |
| TENSION: | 3 to 5 | 3 to 5 | 7 to 9 |
| GAUGE: | 2" 18 sts. 25 rows | 17 sts. 25 rows | 15 sts. 23 rows |

The instructions are the same for all sizes. PATTERN: Stockinette Stitch with Color Stripes as marked in the Diagrams. DECREASES: Hang the 4th st. onto the 3rd st. then move the end sts. inward to fill the empty needle. DRESS INCREASES: Move the 2 end sts. 1 needle outward, then place the 3rd st. from the row below onto the empty needle. FRONT of HOOD INCREASES: Move the 18 stitches on the front edge 1 needle outward, then place the 19th st. from the row below onto the empty needle.

FINISHING: Block all sections. Weave the Back sections, then the front sections together, 1 st. in from each edge. Join front and back section at sides and shoulders. Sew the sleeves together and set in. Turn under 20 rows on lower edge and 15 rows on sleeve edges and hem to wrong side. Join the side sections of the hood to the hood center section, then sew the hood to the neckline. Turn under 13 sts. on the front edges of the dress and hood, then hem to wrong side. Sew 3 ornamental frogs to the front opening. (See picture).



Work the second front section with reverse shapings, casting on from right to left. (Cam Box will be on the LEFT side at Row 0).

ON CAM BOX SIDE, bind off 26 sts. after Row 555 (ODD ROWS = NECK SHAPING); 3 sts. after Row 557; 2 sts. after Rows 559, 561; 1 st. after Row 563; 4 sts. after Row 564 (EVEN ROWS = SHOULDER SHAPING); 1 st. after Row 565; 4 sts. after Row 566; 1 st. after Row 567; 4 sts. after Row 568; 1 st. after Row 569; 4 sts. after Rows 570, 572, 574, 576, 578; 5 sts. after Row 580.

ON CAM BOX SIDE, bind off 4 sts. after Row 470; 3 sts. after Rows 472, 474; 2 sts. after Rows 476, 478; 1 st. after Rows 480, 482, 484, then knit to Row 555.

Work the front section the same as the back section to ROW 445, then cast on 13 sts. ON CAM BOX SIDE, and work Short Rows for the DART, ON OPPOSITE SIDE of CAM BOX, put into holding position 7 needles after Rows 445, 447, 449, 451, 453. After Row 455 bring all needles back into working position, then knit to Row 470.

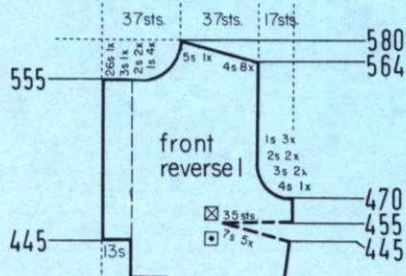
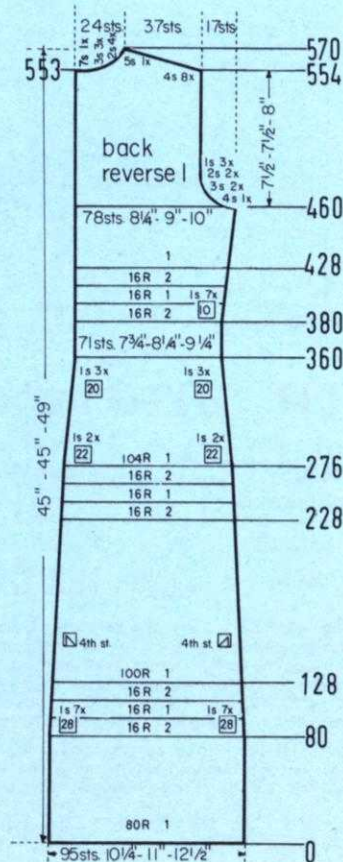

ON CAM BOX SIDE, bind off 3 sts. after Rows 178, 179; 2 sts. after Rows 180, 181, 182, 183, 184, 185, 186, 187; 1 st. after Rows 188, 189; 2 sts. after Rows 190, 191; 1 st. after Rows 192, 193; 2 sts. after Rows 194, 195; 1 st. after Rows 196, 197; 2 sts. after Rows 198, 199; 1 st. after Rows 200, 201; 2 sts. after Rows 202, 203; 1 st. after Rows 204, 205; 2 sts. after Rows 206, 207; 1 st. after Rows 208, 209; 2 sts. after Rows 210, 211; 1 st. after Rows 212, 213; 2 sts. after Rows 214, 215; 1 st. after Rows 216, 217; 2 sts. after Rows 218, 219, 220, 221, 222, 223, 224, 225; 3 sts. after Rows 226, 227, 228, 229; 9 sts. after Row 230.

ON EACH SIDE, increase 1 st. after Rows 30, 38, 46, 54, 62, 70, 78, 86, 94, 102, 110, 118, 126, 134, 142, 148, 154, 160, 166, 172, then knit to Row 178.

ROWS 0 to 30: Knit even, then change to stockinette st.

Cast on 63 sts. with color 1 and work K1, P1, Ribbing.

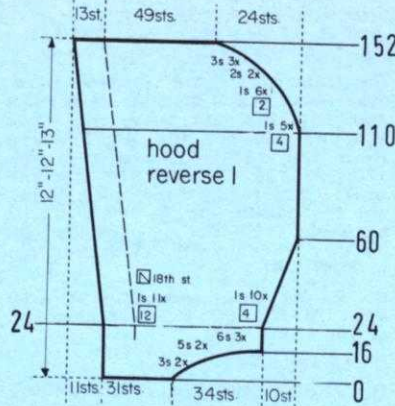

ON CAM BOX SIDE, bind off 5 sts. after Rows 220, 221; 3 sts. after Rows 222, 223, 224, 225; 2 sts. after Rows 226, 227, 228, 229, 230, 231. ON EACH SIDE, hang the 1st st. onto the 2nd st. after Rows 232, 234, 236, 238, 240, 242, 244, 246, 248, 250, 252, 254, 256, 258, 260, 262, 264, 266, 268, 270, 272, 274. ON CAM BOX SIDE, bind off 2 sts. after Rows 276, 277, 278, 279, 280, 281; 3 sts. after Rows 282, 283, 284, 285; 13 sts. after Row 286.

Change to the proper Color after Rows in (). ON EACH SIDE, increase 1 st. after Rows 30, 38, 46, (46), 54, 62, (62), 70, 78, (78), 86, 94, 102, 110, 118, 126, 134, 142, (142), 148, 154, (154), 160, 166, 172, (174), 178, 184, 190, (190), 196, 202, 208, 214, then knit to Row 220.

ROWS 0 to 30: Knit even, then change to color 2 and work the Color Stripes as marked in the Diagram.

Cast on 61 sts. with color 1 and work stockinette st.

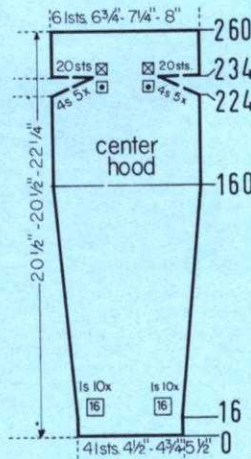

ON EACH SIDE, increase 1 st. after Rows 16, 32, 48, 64, 80, 96, 112, 128, 144, 160, then knit to Row 224 and work Short Rows. ON OPPOSITE SIDE of CAM BOX put into holding position 4 needles after Rows 224, 225, 226, 227, 228, 229, 230, 231, 232, 233. ON OPPOSITE SIDE of CAM BOX bring all needles back into working position after Rows 234, 235, then knit to Row 260 and bind off all 61 sts.

ROWS 0 to 16: Knit even.

Cast on 41 sts. with color 1 and work stockinette st.

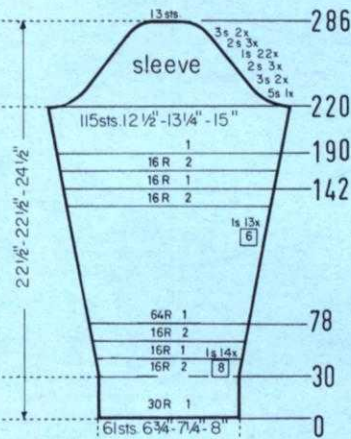

Work the second back section with reverse shapings, casting on from right to left. (Cam Box will be on the LEFT side at Row 0).

ON CAM BOX SIDE, bind off 7 sts. after Row 553 (ODD ROWS = NECK SHAPING); 4 sts. after Row 554 (EVEN ROWS = SHOULDER SHAPING); 3 sts. after Row 555; 4 sts. after Row 556; 3 sts. after Row 557; 4 sts. after Row 558; 3 sts. after Row 559; 4 sts. after Row 560; 2 sts. after Row 561; 4 sts. after Row 562; 2 sts. after Row 563; 4 sts. after Row 564; 2 sts. after Row 565; 4 sts. after Row 566; 2 sts. after Row 567; 4 sts. after Row 568; 5 sts. after Row 570.

ON CAM BOX SIDE, bind off 4 sts. after Row 460; 3 sts. after Rows 462, 464; 2 sts. after Rows 466, 468; 1 st. after Rows 470, 472, 474, then knit to Row 553.

ON CAM BOX SIDE, increase 1 st. after Rows 380, 390, (396), 400, 410, (412), 420, (428), 430, 440, then knit to Row 460. (For the FRONT Section knit to Row 445).

Change to the proper Color after Rows in (). ON EACH SIDE, decrease 1 st. after Rows 80, (96), 108, (112), (128), 136, 164, 192, 220, (228), (244), 248, (260), 276, (276), 298, 320, 340, 360, then knit to Row 380, (380).

ROWS 0 to 80: Knit even, then change to color 2 and work the Color Stripes as marked in the Diagram.

Cast on 95 sts. with color 1 and work stockinette st.

DK 8107

| SIZE: | 12 (Bust 33"-34") | 14 (Bust 36"-37") |
|---------------|--|---|
| YARN: | Allegro Dralon | Alanda |
| 50 gr. BALLS: | | |
| Jacket: | 6 Color 1 4 Color 2 4 Color 3 7 Color 1 | 9 Color 1 6 Color 2 6 Color 3 11 Color 1 |
| Skirt: | 6 Color 2 | 9 Color 2 |
| TENSION: | 6 to 8 | 7 to 9 |
| GAUGE: | 2" 15 sts. 23 rows | 14 sts. 21 rows |



The instructions are the same for both sizes. PATTERN: Stockinette Stitch, and repeated Color Stripes as marked in the Diagrams. The Jacket is knitted sideways and begins at the side edges. Pullover and Cap EDGES: K1, P1, Ribbing. INCREASES: Move the 2 end sts. 1 needle outward, then place the 3rd st. from the row below onto the empty needle. DECREASES: Hang the 3rd st. onto the 2nd st., then move the end sts. inward to fill the empty needles. Begin the CAP DARTS by hanging the sts. together as marked in the Diagram, then move the sts. together to fill the empty needle. The following decreases for the DARTS lie directly above.

FINISHING: Block all sections. JACKET: Join the back sections at center back. Join back and front sections at sides and shoulders. Sew the sleeves together and set in. Turn under 12 sts. on sleeve edges and hem to wrong side. Turn under the facing at front edges and hem to wrong side. Join the hem sections and sew to lower edge, then turn to wrong side and sew in place. Turn under 14 rows on upper edge of the pockets and hem to wrong side. Sew the pockets in place. Fold the collar in half and sew the open side edges together. Sew 1 edge of the collar to inside and 1 edge to outside of neckline, leaving about 1 1/2" to 1 3/4" free on each front edge. (See picture). Finish the buttonholes, sew on buttons. SKIRT: Weave all sections together, 1 st. in from each edge, leaving about 6"-7" free on one seam for the zipper. Turn under a small amount around the opening and hem to wrong side. Work 1 row of slip st. crochet over the center st. of each panel. Gather the upper edge of the skirt to waist measurement, then sew 1 edge of the waist band to inside and 1 edge to outside of upper edge. Insert an elastic band into the waist band and sew in place. Sew a zipper into the opening. Turn under 18 rows on lower edge and hem to wrong side. PULLOVER: Join front and back section at sides and shoulders. Join short ends of armhole bands and short ends of neckband, then sew the bands in place. CAP: Weave the section together at center back. Pull the sts. held on the strands of yarn tightly together and fasten the yarn ends securely.

Continued on pages 20 & 21

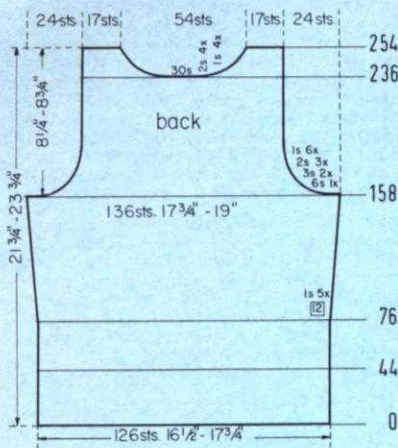

Move the Cam Box to the left side, turn the Row Counter back to 236 and complete the left half. Follow the instructions from*.

*ON CAM BOX SIDE, bind off 2 sts. after Rows 237, 239, 241, 243; 1 st. after Rows 245, 247, 249, 251. After Row 254 bind off the 17 shoulder sts.

ON CAM BOX SIDE, bind off 6 sts. after Rows 158, 159; 3 sts. after Rows 160, 161, 162, 163; 2 sts. after Rows 164, 165, 166, 167, 168, 169; 1 st. after Rows 170, 171, 172, 173, 174, 175, 176, 177, 178, 179, 180, 181, then knit to Row 236, bind off the center 30 sts., put the needles on the left side into holding position and complete the right half first. (For the FRONT Section knit to ROW 204).

ON EACH SIDE, increase 1 st. after Rows 76, 88, 100, 112, 124, then knit to Row 158.

ROWS 45 to 76: Knit even.

ROWS 0 to 44: Knit even, then change to stockinette st.

Cast on 126 sts. with color 2 and work K1, P1, Ribbing.

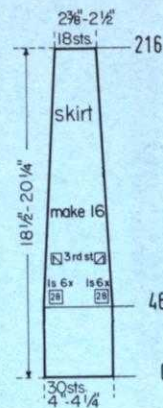

Work 15 more sections the same.

ON EACH SIDE, decrease 1 st. after Rows 46, 74, 102, 130, 158, 186, then knit to Row 216 and bind off the remaining 18 sts.

ROWS 0 to 46: Knit even.

Cast on 30 sts. with color 1 and work stockinette st.

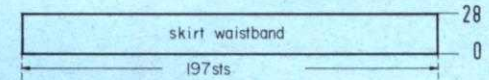

Cast on 197 sts. with color 1 and work 28 rows stockinette st., then bind off all sts.

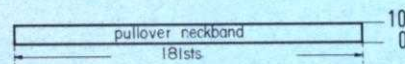

Cast on 181 sts. with color 2 and work 10 rows K1, P1, Ribbing, then bind off all sts.

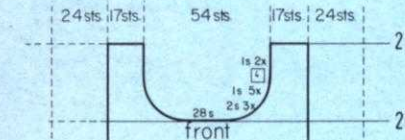

Move the Cam Box to the left side, turn the Row Counter back to 204 and complete the left half. Follow the instructions from*.

*ON CAM BOX SIDE, bind off 2 sts. after Rows 205, 207, 209; 1 st. after Rows 211, 213, 215, 217, 219, 221, 225, then knit to Row 254 and bind off the 17 shoulder sts.

Work the front section the same as the back section to ROW 204, then bind off the center 28 sts., put the needles on the left side into holding position and complete the right half first.

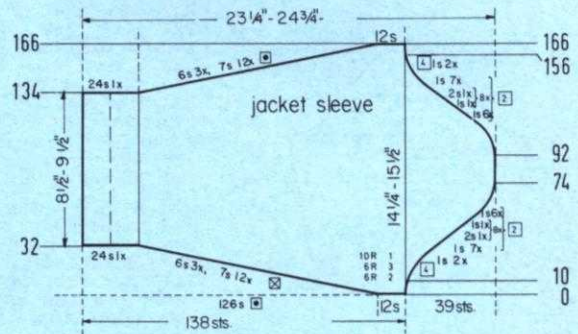

Decrease 1 st. ON EACH SIDE and 2 sts. for EACH DART after Rows 54, 58, 62, 66, 70, 74, 78, 82, 86, 90. After Row 94 take the sts. off the machine as follows: Using a ribber transfer needle and color 2, thread the 1st, 3rd, 5th, 7th, etc. sts. onto a length of yarn, then thread the 2nd, 4th, 6th, 8th, etc., sts. onto a separate length of yarn.

ROWS 0 to 16: Knit even, then transfer the ribber sts. to the main machine, work stockinette st. and Short Rows. ON OPPOSITE SIDE of CAM BOX put into holding position 49 needles after Rows 16, 17. ON OPPOSITE SIDE of CAM BOX bring back into working position 7 needles after Rows 18, 19, 20, 21, 22, 23, 24, 25, 26, 27, 28, 29, 30, 31, then knit to Row 54.

Cast on 168 sts. with color 2 and work K1, P1, Ribbing.

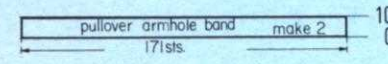

Cast on 171 sts. with color 2 and work 10 rows K1, P1, Ribbing, then bind off all sts.

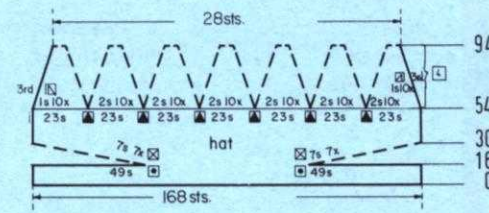

jac40 is a must

for fast easy knitting of
Jacquard and Ski-sweater
designs

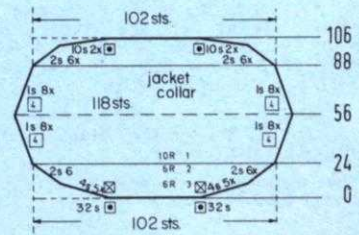
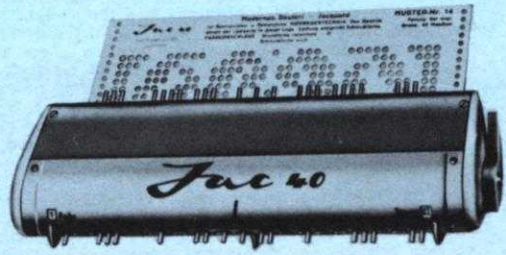

ON CAM BOX SIDE, bind off 1 st. after Rows 92, 94, 96, 98, 100, 102, 104; 2 sts. after Row 106; 1 st. after Row 108; 2 sts. after Row 110; 1 st. after Row 112; 2 sts. after Row 114; 1 st. after Row 116; 2 sts. after Row 118; 1 st. after Row 120; 2 sts. after Row 122; 1 st. after Row 124; 2 sts. after Row 126; 1 st. after Row 128; 2 sts. after Row 130; 1 st. after Row 132; 2 sts. after Row 134 AND ON OPPOSITE SIDE of CAM BOX put into holding position 24 needles after Row 134. Continue to bind off 1 st. ON CAM BOX SIDE after Rows in (). ON OPPOSITE SIDE of CAM BOX put into holding position 6 needles after Rows 136, (136), 138, (138), 140; (140), 7 needles after Rows 142, (142), 144, (144), 146, (146), 148, (148), 150, 152, (152), 154, 156, (156), 158, 160, 162, 164. After Row 166 bring all needles back into working position, then bind off all sts.

ON OPPOSITE SIDE of CAM BOX put into holding position 126 sts. after Row 0. ON OPPOSITE SIDE of CAM BOX bring back into working position 7 needles after Rows 2, 4, 6, 8, then knit to Row 10. Cast on 1 st. ON CAM BOX SIDE after Rows in (). Continue to put into working position 7 needles after Rows 10, (10), 12, 14, (14), 16, 18, (18), 20, (20), 22, (22), 24; (24), 6 needles after Rows 26, (26), 28, (28), 30; (30), 24 needles after Row 32. The Side Arm Shaping is now completed. ON CAM BOX SIDE, cast on 2 sts. after Row 32; 1 st. after Row 34; 2 sts. after Row 36; 1 st. after Row 38; 2 sts. after Row 40; 1 st. after Row 42; 2 sts. after Row 44; 1 st. after Row 46; 2 sts. after Row 48; 1 st. after Row 50; 2 sts. after Row 52; 1 st. after Row 54; 2 sts. after Row 56; 1 st. after Row 58; 2 sts. after Row 60; 1 st. after Rows 62, 64, 66, 68, 70, 72, 74, then knit to Row 92.

Cast on 138 sts. with color 2, work stockinette st., the repeated color stripes as marked in the Diagram and Short Rows.

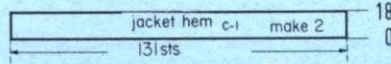

Cast on 131 sts. with color 1 and work 18 rows stockinette st., then bind off all sts.

Work the second back section with reverse shapings, casting on from right to left. (Cam Box will be on the LEFT side at Row 0).

ON CAM BOX SIDE, bind off 2 sts. after Row 82; 1 st. after Rows 84, 86, 88, 90, then knit to Row 104 and work Short Rows. ON OPPOSITE SIDE of CAM BOX (Lower Edge) put into holding position 81 needles after Row 104; 17 needles after Rows 106, 108, 110. After Row 112 put all needles into holding position, move the Cam Box to the left side, (right side for the second section) turn the Row Counter to 104 and work Short Rows. ON CAM BOX SIDE, bring into working position 69 sts. after Row 104. ON OPPOSITE SIDE of CAM BOX (Below the waistline) put into holding position 18 needles after Rows 106, 108, 110. (15 sts. remain) After Row 112 bring ALL needles back into working position and bind off all 191 sts.

ON CAM BOX SIDE, cast on 1 st. after Rows 34, 40, 46, 52, 58, 64, 70, 74, 78, then knit to Row 82.

ON CAM BOX SIDE, cast on 1 st. after Rows 12, 14, 16, 18; 2 sts. after Rows 20, 22; 3 sts. after Rows 24, 26; 42 sts. after Row 28.

ROWS 0 to 12: Knit even.

Cast on 132 sts. with color 1, work stockinette st. and the color stripes as marked in the Diagram. (ALL 197 needles will be used. Cast on beginning with the 1st needle on the left side. For the second back section begin with the 1st needle on the right side.)

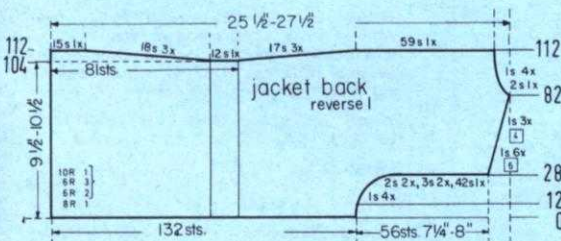

Cast on 102 sts. with color 3, work stockinette st., the color stripes as marked in the Diagram and Short Rows. ON OPPOSITE SIDE of CAM BOX put into holding position 32 needles after Rows 0, 1. ON OPPOSITE SIDE of CAM BOX bring back into working position 4 needles after Rows 2, 3, 4, 5, 6, 7, 8, 9, 10, 11; 2 sts. after Rows 12, 13, 14, 15, 16, 17, 18, 19, 20, 21, 22, 23, then knit to Row 24. ON EACH SIDE, increase 1 st. after Rows 24, 28, 32, 36, 40, 44, 48, 52. ON EACH SIDE, decrease 1 st. after Rows 60, 64, 68, 72, 76, 80, 84, 88. ON OPPOSITE SIDE of CAM BOX put into holding position 2 needles after Rows 88, 89, 90, 91, 92, 93, 94, 95, 96, 97, 98, 99; 10 needles after Rows 100, 101, 102, 103. ON OPPOSITE SIDE of CAM BOX bring all needles back into working position after Rows 104, 105. After Row 106 bind off all sts.

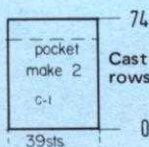
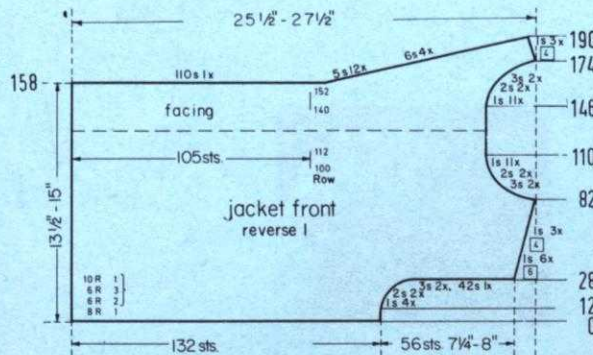

Cast on 39 sts. with color 1 and work 74 rows stockinette st., then bind off all sts.

Work the second front section with reverse shapings, casting on from right to left. (Cam Box will be on the LEFT side at Row 0). Omit the buttonholes.

ON OPPOSITE SIDE of CAM BOX put into holding position 110 needles after Row 158; ON NECK SIDE, cast on 1 st. after Row 160, then again after Rows in (). ON OPPOSITE SIDE of CAM BOX put into holding position 5 needles after Rows 160, 162, (162), 164, (164), 166, (166), 168. ON NECK SIDE, cast on 2 sts. after Row 168, then again after Row in (). ON OPPOSITE SIDE of CAM BOX put into holding position 5 needles after Rows 170, (170), 172. ON NECK SIDE, cast on 3 sts. after Row 172, then again after Row in (). Continue to put 5 needles into holding position after Rows 174, (174), 176, 178. For SHOULDER bind off 1 st. after Row 178, then again after Rows in (). Continue to put into holding position 5 needles after Rows 180, 182; (182), 6 needles after Rows 184, 186, (186), 188, (188) needles remain). After Row 190 bring all needles back into working position, then bind off 194 sts.

ON CAM BOX SIDE, cast on 1 st. after Rows 152, 154, 156, 158, but do not knit after the last cast on. Work Short Rows.

Knit even to Row 146, then cast on 1 st. ON CAM BOX SIDE (NECK SIDE), after Rows 146, 148, 150. After Row 152 put the upper needles into holding position, turn the Row Counter back to 140, bring the lower 105 needles into working position, then knit in PATTERN over 105 needles to Row 152. Move the Cam Box to Neck Side, bring all needles back into working position and continue working over all needles.

ROWS 113 to 140: Knit even, then put 105 needles on OPPOSITE SIDE of CAM BOX (Lower Edge) into holding position and work over the upper edge needles to form a buttonhole.

Continue to bind off 1 st. ON NECK SIDE after Rows 100, 102, 104, 106, 108, 110. Knit to Row 112, put the upper needles into holding position, turn the Row Counter back to 100, bring the lower 105 needles into working position, then knit in PATTERN over 105 needles to Row 112. Move the Cam Box to the Neck Side, bring all needles back into working position and continue working over all needles.

ON CAM BOX SIDE, bind off 3 sts. after Rows 82, 84; 2 sts. after Rows 86, 88; 1 st. after Rows 90, 92, 94, 96, 98, then knit to Row 100, put 105 sts. ON OPPOSITE SIDE of CAM BOX (Lower Edge) into holding position and work over the upper edge needles to form a buttonhole.

ON CAM BOX SIDE, cast on 1 st. after Rows 34, 40, 46, 52, 58, 64, 70, 74, 78, then knit to Row 82.

ON CAM BOX SIDE, cast on 1 st. after Rows 12, 14, 16, 18; 2 sts. after Rows 20, 22; 3 sts. after Rows 24, 26; 42 sts. after Row 28.

ROWS 0 to 12: Knit even.

Cast on 132 sts. with color 1, work stockinette st. and the color stripes as marked in the Diagram. (ALL 197 needles will be used. Cast on beginning with the 1st needle on the left side. For the second front section begin with the 1st needle on the right side.)

BE SURE TO NOTIFY US IMMEDIATELY OF ANY CHANGE OF ADDRESS. THE POST OFFICE WILL NOT FORWARD YOUR MAGAZINE TO YOU.

DV 8098

| | | | |
|---------------|--|------------------------------------|------------------------------------|
| SIZE: | Small (Bust 31"-33") | Medium (Bust 34"-35") | Large (Bust 37"-38") |
| YARN: | Flamingo Dralon | Flamingo Dralon | Flamingo Dralon |
| 50 gr. BALLS: | 9 | 10 | 11 |
| TENSION: | Stock: 7 to 9 Pattern: 6 to 8 | 8 to 10 7 to 9 | 9 to 10 8 to 10 |
| GAUGE: | 2" Stk.: 14 sts. 19 rows Pattern: 14 sts. 30 rows | 13 sts. 18 rows 13 sts. 29 rows | 12 sts. 17 rows 12 sts. 28 rows |

The instructions are the same for all sizes. **PATTERN:** Lower Section and Sleeves: Stockinette Stitch. Yoke: Holding Position Design with omitted needles according to the Line Drawing. The omitted needles do count as stitches in the Gauge and instructions. **DECREASES:** Hang the 3rd st. onto the 2nd st., then move the end sts. inward to fill the empty needle. To form the hem, hang the cast-on sts. back onto the machine behind the latches and knit the following row with 1 tension setting higher.

FINISHING: Block all sections. Join back and front sections at sides and shoulders. Sew the sleeves together and set in. Insert an elastic band into the sleeve hem. Turn under 8 sts. on front edges and hem to wrong side. Work 1 row of single crochet and 2 row of reverse single crochet around the neckline. Work 6 loops on the right front edge and sew 6 buttons to the left front edge. (See picture).

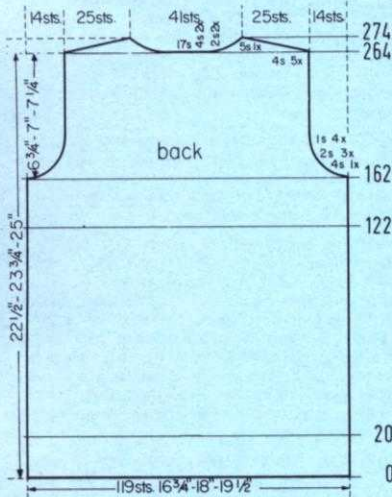
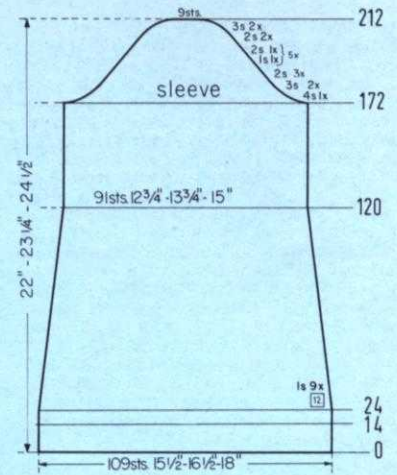

Bring the needles on the left side into working position, knit 1 row in **PATTERN** to the left side, turn the Row Counter back to 264 and complete the left half. Follow the instructions from*.

*ON CAM BOX SIDE, bind off 4 sts. after Rows 264 (EVEN ROWS = SHOULDER SHAPING), 265 (ODD ROWS = NECK SHAPING), 266, 267, 268; 2 sts. after Row 269; 4 sts. after Row 270; 2 sts. after Row 271; 4 sts. after Row 272; 5 sts. after Row 274.

ON CAM BOX SIDE, bind off 4 sts. after Rows 162, 163; 2 sts. after Rows 164, 165, 166, 167, 168, 169; 1 st. after Rows 170, 171, 172, 173, 174, 175, 176, 177, then knit to Row 264, bind off the center 17 sts., put the needles on the left side into holding position and complete the right half first.

ROWS 123 to 162: Knit even.

ROWS 21 to 122: Knit even, then transfer the appropriate sts. to the neighboring needles, put the empty needles into the non-working position and work the Holding Position Design.

ROWS 0 to 20: Knit even, then form the hem.

Cast on 119 sts. and work stockinette st.

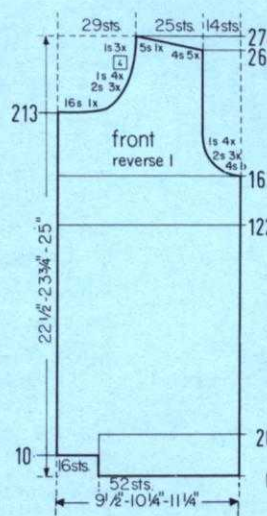
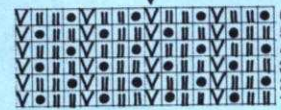

Work the second front section with reverse shapings, casting on from right to left. (Cam Box will be on the LEFT side at Row 0).

ON CAM BOX SIDE, bind off 16 sts. after Row 213; 2 sts. after Rows 215, 217, 219; 1 st. after Rows 221, 223, 225, 227, 229, 233, 237. For SHOULDER bind off 4 sts. after Rows 264, 266, 268, 270, 272; 5 sts. after Row 274.

ON CAM BOX SIDE, bind off 4 sts. after Row 162; 2 sts. after Rows 164, 166, 168; 1 st. after Rows 170, 172, 174, 176, then knit to Row 213.

ROWS 123 to 162: Knit even.

ROWS 21 to 122: Knit even, then transfer the appropriate sts. to the neighboring needles, put the empty needles into the non-working position and work the Holding Position Design.

ROWS 11 to 20: Knit even, then form the hem. (First 52 cast-on sts. only).

ROWS 0 to 10: Knit even, then cast on 16 sts. ON OPPOSITE SIDE OF CAM BOX. (Use a separate length of yarn).

Cast on 52 sts. and work stockinette st.

KK 5380

| | |
|---------------|--|
| SIZE: | 3 to 9 Months |
| YARN: | Allegro Dralon |
| 50 gr. BALLS: | 3 balls (Color 1) 1 ball (Color 2) Subita Crepe 2 x 3 2 balls |
| Top: | |
| TENSION: | Pants: 6 to 8 Top: 5 to 7 |
| GAUGE: | 2" Pants: 15 sts. 21 rows Top: 17 sts. 23 rows |

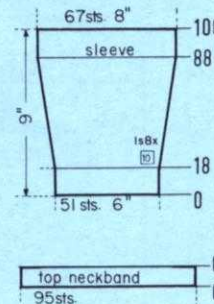

ON EACH SIDE, increase 1 st. after Rows 18, 28, 38, 48, 58, 68, 78, 88, then knit to Row 106 and bind off all 67 sts. Work the second sleeve the same.

ROWS 0 to 18: Knit even, then change to stockinette st.

Cast on 51 sts. and work K1, P1, Ribbing.

Cast on 95 sts. and work 6 rows K1, P1, Ribbing, then bind off all sts.

PATTERN: Stockinette Stitch. The PANTS have repeated Color Stripes of 6 rows Color 2 and 6 Rows Color 1 from ROWS 0 to 66 and ROWS 208 to 238. **INCREASES:** Move the 2 end sts. 1 needle outward, then place the 3rd st. from the row below onto the empty needle. **DECREASES:** Hang the 3rd st. onto the 2nd st., then move the end sts. inward to fill the empty needle. Bind off all bands the crochet method for ribbing.

FINISHING: Block all sections. PANTS: Weave the front and back section together at sides, 1 st. in from each edge. Weave the inner leg seams together. Join the crotch. Weave the open sts. of the front and back section together. (HEEL). Join the sole to the instep. Join the neckbands to the armhole bands, then sew the bands in place, leaving 2 spaces on each front shoulder for buttonholes. (See picture). Finish buttonholes, sew on buttons. TOP: Join the shoulders. Sew the sleeves together and set in. Turn under 6 sts. on the open back edges and hem to wrong side. Sew the neckband to neckline. Work 2 loops to 1 side and sew 2 buttons to other side on upper part of the back opening.

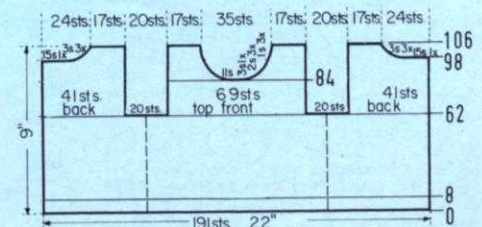

ON CAM BOX SIDE, bind off 4 sts. after Rows 172, 173; 3 sts. after Rows 174, 175, 176, 177; 2 sts. after Rows 178, 179, 180, 181, 182, 183; 1 st. after Rows 184, 185; 2 sts. after Rows 186, 187; 1 st. after Rows 188, 189; 2 sts. after Rows 190, 191; 1 st. after Rows 192, 193; 2 sts. after Rows 194, 195; 1 st. after Rows 196, 197; 2 sts. after Rows 198, 199; 1 st. after Rows 200, 201; 2 sts. after Rows 202, 203, 204, 205, 206, 207; 3 sts. after Rows 208, 209, 210, 211; 9 sts. after Row 212.

ON EACH SIDE, decrease 1 st. after Rows 24, 36, 48, 60, 72, 84, 96, 108, 120, then knit to Row 172.

ROWS 15 to 24: Knit even.

ROWS 0 to 14: Knit even, then form the hem.

Cast on 109 sts. and work stockinette st.

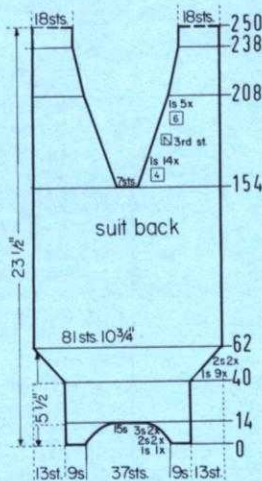

Move the Cam Box to the left side, turn the Row Counter back to 84 and complete the left half. Follow the instructions from**.

**ON CAM BOX SIDE, bind off 3 sts. after Row 85; 2 sts. after Rows 87, 89, 91; 1 st. after Rows 93, 95, 97. After Row 106 bind off the 17 shoulder sts.

ROWS 63 to 84: Knit even, then bind off the center 11 sts., put the needles on the left side into holding position and complete the right half first.

Move the Cam Box to the left side, turn the Row Counter back to 62 and complete the left side. Follow the instructions from * to *. After completing the left side, move the Cam Box to the right side, turn the Row Counter back to 62 and work the center section.

ON CAM BOX SIDE, bind off 15 sts. after Row 98; 3 sts. after Rows 100, 102, 104. After Row 106 bind off the 17 shoulder sts.*

*ROWS 63 to 98: Knit even.

ROWS 9 to 62: Knit even, then bind off 20 sts. on each side, beginning with the 42nd st. ON EACH SIDE. (ARMHOLES) Put 41 needles on the left side and 69 needles in the center into holding position and complete the right side first.

ROWS 0 to 8: Knit even, then change to stockinette st.

Cast on 191 sts. and work K1, P1, Ribbing.

Move the Cam Box to the left side, turn the Row Counter back to 154 and work the left half. Follow the instructions from**.

**ON OPPOSITE SIDE of CAM BOX decrease 1 st. after Rows 158, 162, 166, 170, 174, 178, 182, 186, 190, 194, 198, 202, 206, (work the repeated Color Stripes after Row 208) 210, 214, 220, 226, 232, 238. After Row 238 change to color 1, transfer every other st. to the ribber and work K1, P1, Ribbing. After Row 250 put all 18 sts. onto a stitch holder.

ROWS 62 to 154: Continue with color 1 after Row 66, then knit to Row 154, bind off the center 7 sts., put the needles on the left side into holding position and complete the right half first.

ON EACH SIDE, increase 1 st. after Rows 40, 42, 44, 46, 48, 50, 52, 54, 56. ON CAM BOX SIDE, cast on 2 sts. after Rows 58, 59, 60, 61.

ROWS 15 to 40: Knit even.

ON CAM BOX SIDE, cast on 1 st. after Row 3; 2 sts. after Rows 5, 7; 3 sts. after Rows 9, 11; 8 sts. (7 sts. for the left half) after Row 13. Move the Cam Box to the left side, put the needles on the right side into holding position, bring the 9 needles with the cast-on sts. into working position, turn the Row Counter to 0 and work the left half. Follow the instructions from * to *. After Row 13 put all needles into holding position, move the Cam Box to the left side, bring all needles into working position and knit to the right side. Turn Row Counter to 14.

Using a separate ball of Color 2 yarn for each side, cast on 9 sts. on each side, leaving the center 37 needles free and in the non-working position. On the LEFT side, put the 9 needles with the cast-on sts. into holding position and work the right half first.

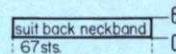
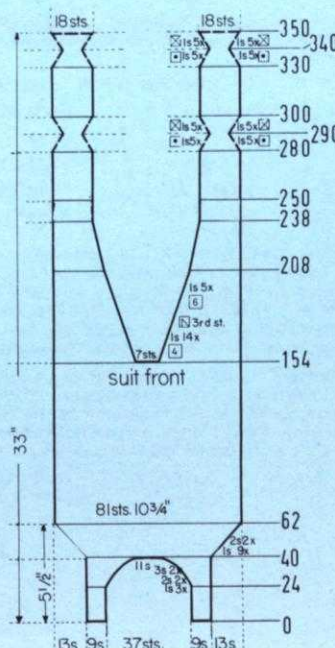

Cast on 67 sts. and work 6 rows K1, P1, Ribbing, then bind off all sts.

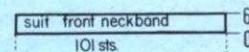

Cast on 101 sts. and work 6 rows K1, P1, Ribbing, then bind off all sts.

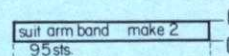

Cast on 95 sts. and work 6 rows K1, P1, Ribbing, then bind off all sts.

Move the Cam Box to the left side, turn the Row Counter back to 154 and complete the left half. Follow the instructions from**.

ROWS 251 to 280: Knit even, then work Short Rows. ON OPPOSITE SIDE of CAM BOX put into holding position 1 needle after Rows 280, 281, 282, 283, 284, 285, 286, 287, 288, 289. ON OPPOSITE SIDE of CAM BOX bring back into working position 1 needle after Rows 290, 291, 292, 293, 294, 295, 296, 297, 298, 299, then knit to Row 330 and knit Short Rows. ON OPPOSITE SIDE of CAM BOX put into holding position 1 needle after Rows 330, 331, 332, 333, 334, 335, 336, 337, 338, 339. ON OPPOSITE SIDE of CAM BOX bring back into working position 1 needle after Rows 340, 341, 342, 343, 344, 345, 346, 347, 348, 349. After Row 350 put all 18 sts. onto a stitch holder.

ON OPPOSITE SIDE of CAM BOX, decrease 1 st. after Rows 158, 162, 166, 170, 174, 178, 182, 186, 190, 194, 198, 202, 206, (work the repeated Color Stripes after Row 208) 210, 214, 220, 226, 232, 238. After Row 238 transfer every other st. to the ribber and continue with color 1. Work K1, P1, Ribbing to Row 250. After Row 250 transfer the ribber sts. back onto the main machine and work stockinette st.

**ROWS 155 to 158: Knit even.

ROWS 62 to 154: Continue with color 1 after Row 66 and knit even to Row 154, then bind off the center 7 sts., put the needles on the left side into holding position and complete the right half first.

ON EACH SIDE, increase 1 st. after Rows 40, 42, 44, 46, 48, 50, 52, 54, 56. ON CAM BOX SIDE, cast on 2 sts. after Rows 58, 59, 60, 61.

ROWS 0 to 24: Knit even. ON CAM BOX SIDE, cast on 1 st. after Rows 25, 27, 29; 2 sts. after Rows 31, 33; 3 sts. after Rows 35, 37; 6 sts. (5 sts. for the left half) after Row 39. After Row 39, put these needles into holding position, move the Cam Box to the left side bring the 9 needles with the cast-on sts. into working position and work the left half. Follow the instructions from * to *. After Row 39 put all needles into holding position, move the Cam Box to the left side, turn the Row Counter to 39, bring all needles into working position and work over all 55 sts.

Using a separate ball of Color 2 yarn for each side, cast on 9 sts. on each side, leaving the center 37 needles free and in the non-working position. On the LEFT side, put the 9 needles with the cast-on sts. into holding position and work the right half first.

DV 8102

SIZE: 10/12 (Bust 33"-35") 14/16 (Bust 36"-38")
 YARN: Mohana Mohana
 50 gr. BALLS: 8 9
 TENSION: 8 to 9 9 to 10
 GAUGE: 2" 13 sts. 18 rows 12 sts. 17 rows
 Both Sizes: 5 yards velvet ribbon

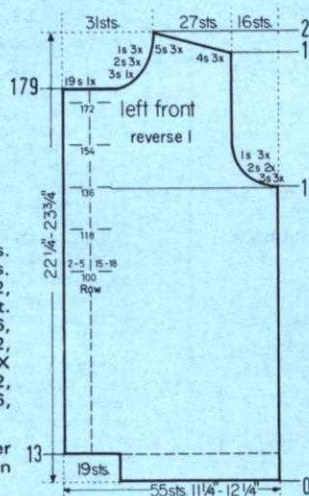
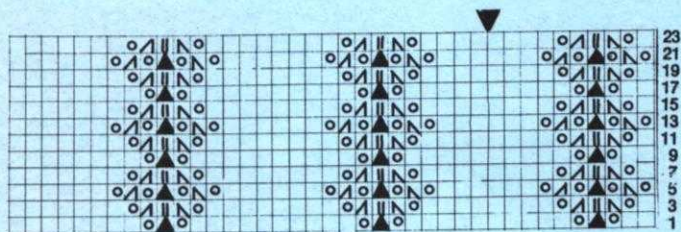
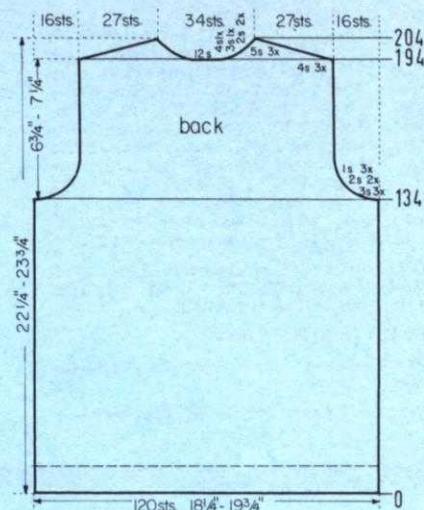

Work the second front section with reverse shapings, casting on from right to left. (Cam Box will be on the LEFT side at Row 0). Make Buttonholes after Rows 100, 118, 136, 154 and 172 over the 2nd-5th and 15th-18th sts. counting from the right side.

ON CAM BOX SIDE, bind off 19 sts. after Row 179; 3 sts. after Row 181; 2 sts. after Rows 183, 185, 187; 1 st. after Rows 189, 191, 193. For SHOULDER bind off 4 sts. after Rows 194, 196, 198; 5 sts. after Rows 200, 202, 204.

ON CAM BOX SIDE, bind off 3 sts. after Rows 134, 136, 138; 2 sts. after Rows 140, 142; 1 st. after Rows 144, 146, 148, then knit to Row 179.

ROWS 14 to 134: Knit even, then change to stockinette st.

ROWS 0 to 13: Knit even, then cast on 19 sts. ON CAM BOX SIDE.

Cast on 55 sts. and work the Eyelet Design. (Do NOT make buttonholes in the first section).

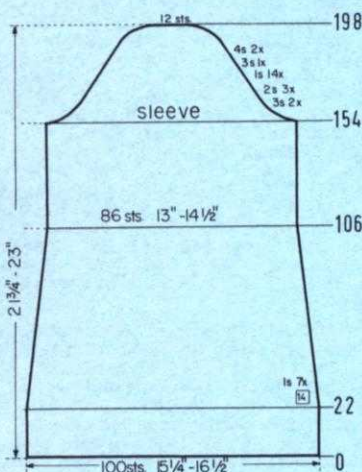

ON CAM BOX SIDE, bind off 3 sts. after Rows 154, 155, 156, 157; 2 sts. after Rows 158, 159, 160, 161, 162, 163. ON EACH SIDE, hang the 1st st. onto the 2nd st. after Rows 164, 166, 168, 170, 172, 174, 176, 178, 180, 182, 184, 186, 188, 190. ON CAM BOX SIDE, bind off 3 sts. after Rows 192, 193; 4 sts. after Rows 194, 195, 196, 197; 12 sts. after Row 198.

ON EACH SIDE, decrease 1 st. after Rows 22, 36, 50, 64, 78, 92, 106, then knit to Row 154.

ROWS 0 to 20: Knit even, then transfer every other st. to the neighboring needle, leave the empty needles in working position and knit 2 rows. This will form an Eyelet Row for the elastic band.

Cast on 100 sts. and work stockinette st.

DK 8137

SIZE: 12 (Bust 34"-35") 14 (Bust 36"-37") 16 (Bust 38"-39")
 YARN: Subita Crepe 2 x 3 Beatrice Regia
 50 gr. BALLS: 11 14 13
 TENSION: 3 to 5 4 to 6 4 to 6
 GAUGE: 2" 18 sts. 25 rows 17 sts. 24 rows 16 sts. 23 rows
 ZIPPER: 20" 20" 21"



The instructions are the same for all sizes. PATTERN: Stockinette Stitch. DECREASES: Hang the 4th st. onto the 3rd st., then move the end sts. inward to fill the empty needle. INCREASES: Move the 2 end sts. 1 needle outward, then place the 3rd st. from the row below onto the empty needle. Begin the INCREASES for the DARTS by moving the sts. outward as marked in the Diagrams, then hanging the appropriate sts. from the row below onto the 2 empty needles. The following increases for the darts lie directly above.

FINISHING: Block all sections. Weave the skirt sections together, 1 st. in from each edge, leaving the upper center back open for 5". Join back and front sections of the bodice at sides and shoulders. Sew the sleeves together and set in. Join the bodice to the skirt. Work 1 row of slip-stitch crochet around the back opening. Sew 1 edge of the neckband to inside and 1 edge to outside of neckline. Sew in the zipper. Turn under 20 rows on lower edge and 14 rows on sleeve edges and hem to wrong side.

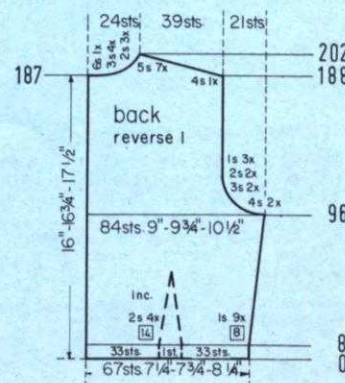

Move the Cam Box to the left side, turn the Row Counter back to 194 and complete the left half. Follow the instructions from*.

*ON CAM BOX SIDE, bind off 4 sts. after Rows 194 (EVEN ROWS = SHOULDER SHAPING), 195 (ODD ROWS = NECK SHAPING), 196; 3 sts. after Row 197; 4 sts. after Row 198; 2 sts. after Row 199; 5 sts. after Row 200; 2 sts. after Row 201; 5 sts. after Rows 202, 204.

ON CAM BOX SIDE, bind off 3 sts. after Rows 134, 135, 136, 137, 138, 139; 2 sts. after Rows 140, 141, 142, 143; 1 st. after Rows 144, 145, 146, 147, 148, 149, then knit to Row 194, bind off the center 12 sts., put the needles on the left side into holding position and complete the right half first.

ROWS 0 to 134: Knit even, then change to stockinette st.

Cast on 120 sts. and work the Eyelet Design.

KK 5378



SIZE: 1 to 2 year
 YARN: Regia
 50 gr. BALLS: 4
 TENSION: 8 to 10
 GAUGE: 2"
 Pattern 1: 14 sts. 38 rows
 Pattern 2: 14 sts. 18 rows

PATTERN: Holding Position Design according to Line Drawing 1. UPPER EDGE: Knit 1, Purl 3 Ribbing according to Line Drawing 2. The purl side is the right side. Set up the Holding Position Design manually, then use the Needle Shifter after every 3 rows to change the needle position. INCREASES: Place the end st. from the row below onto the next empty needle.

FINISHING: Block all sections. PANTS: Join the front and back section at sides and at crotch. Join the short ends of the leg bands, then sew the bands in place. Turn under 12 rows on upper edge and hem to wrong side. Insert an elastic band. TOP: Join front and back section at sides, leaving the upper 5" free. Sew the sleeves together, leaving the upper 5" free. Sew the open edges of the sleeves to the open edges of the front and back section. Insert a twisted cord through the neck edge. (See picture).

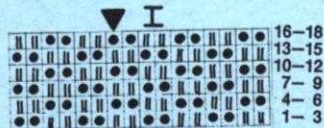

Work the second section the same.

ROWS 138 to 162: Knit even, then bind off all sts.

ROWS 9 to 138: Knit even, then transfer the appropriate sts. to the ribber and work Knit 1, Purl 3, Ribbing according to Line Drawing 2.

ROWS 0 to 8: Knit even, then transfer the ribber sts. to the main machine and work the Holding Position Design according to Line Drawing 1.

Cast on 83 sts. and work K1, P1, Ribbing.

ON CAM BOX SIDE, increase 1 st. after Rows 38, 39, 42, 43, 46, 47, 50, 51; 2 sts. after Rows 54, 55, 58, 59, 62, 63, 66, 67; 3 sts. after Rows 70, 71, 74, 75, 78, 79; 15 sts. after Rows 82, 83, then knit to Row 184, transfer every other st. to the ribber and work K1, P1, Ribbing to Row 202, then bind off all 92 sts.

ROWS 0 to 38: Knit even.

Cast on 20 sts. and work the Holding Position Design according to Line Drawing 1.

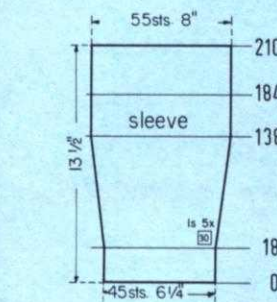

Work the second sleeve the same.

ROWS 185 to 210: Knit even, then bind off all sts.

ON EACH SIDE, increase 1 st. after Rows 18, 48, 78, 108, 138, then knit to Row 184, transfer the appropriate sts. to the ribber and work Knit 1, Purl 3, Ribbing according to Line Drawing 2.

ROWS 0 to 18: Knit even, then transfer the ribber sts. to the main machine and work the Holding Position Design according to Line Drawing 1.

Cast on 45 sts. and work K1, P1, Ribbing.

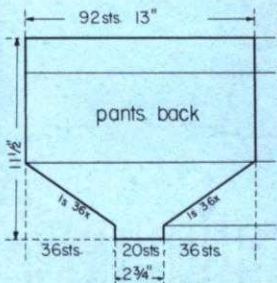

ON EACH SIDE, increase 1 st. after Rows 12, 14, 16, 18, 20, 22, 24, 26, 28, 30, 32, 34, 36, 38, 40, 42, 44, 46, 48, 50, 52, 54, 56, 58, 60, 62, 64, 66, 68, 70, 72, 74, 76, 78, 80, 82, then knit to Row 184, transfer every other st. to the ribber and work K1, P1, Ribbing to Row 202, then bind off all 92 sts.

ROWS 0 to 12: Knit even.

Cast on 20 sts. and work the Holding Position Design according to Line Drawing 1.

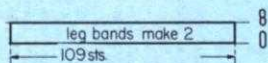
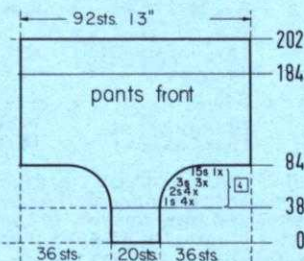
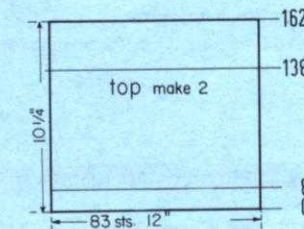

Cast on 109 sts. and work 8 rows K1, P1, Ribbing, then bind off all sts.

Work the second back section with reverse shapings, casting on from right to left. (Cam Box will be on the LEFT side at Row 0).

ON CAM BOX SIDE, bind off 6 sts. after Row 187 (ODD ROWS = NECK SHAPING); 4 sts. after Row 188 (EVEN ROWS = SHOULDER SHAPING); 3 sts. after Row 189; 5 sts. after Row 190; 3 sts. after Row 191; 5 sts. after Row 192; 3 sts. after Row 193; 5 sts. after Row 194; 3 sts. after Row 195; 5 sts. after Row 196; 2 sts. after Row 197; 5 sts. after Row 198; 2 sts. after Row 199; 5 sts. after Row 200; 2 sts. after Row 201; 5 sts. after Row 202.

ON CAM BOX SIDE, bind off 4 sts. after Rows 96, 98; 3 sts. after Rows 100, 102; 2 sts. after Rows 104, 106; 1 st. after Rows 108, 110, 112, then knit to Row 187.

Increase 2 sts. for the DART after Rows in (). ON CAM BOX SIDE, increase 1 st. after Rows 8, (8), 16, (22), 24, 32, (36), 40, 48, (50), 56, 64, 72, then knit to Row 96.

ROWS 0 to 8: Knit even.

Cast on 67 sts. and work stockinette st.

Move the Cam Box to the left side, turn the Row Counter back to 182 and complete the left half. Follow the instructions from*.

*ON CAM BOX SIDE, bind off 3 sts. after Rows 183, 185; 2 sts. after Rows 187, 189, 191; 1 st. after Rows 193, 195, 197, 199, 201. For SHOULDER bind off 4 sts. after Row 202; 5 sts. after Rows 204, 206, 208, 210, 212, 214, 216.

ON CAM BOX SIDE, bind off 4 sts. after Rows 110, 111, 112, 113; 3 sts. after Rows 114, 115, 116, 117; 2 sts. after Rows 118, 119, 120, 121; 1 st. after Rows 122, 123, 124, 125, 126, 127, then knit to Row 182, bind off the center 14 sts., put the needles on the left side into holding position and complete the right half first.

Increase 2 sts. for EACH DART after Rows in (). ON EACH SIDE, increase 1 st. after Rows 8, (8), 16, (22), 24, 32, (36), 40, 48, (50), 56, 64, 72, then knit to Row 76 and work Short Rows for the Bust DARTS. ON OPPOSITE SIDE OF CAM BOX put into holding position 5 needles after Rows 76, 77, 78, 79, 80, 81, 82, 83, 84, 85, 86, 87, 88, 89. ON OPPOSITE SIDE OF CAM BOX bring all needles back into working position after Rows 90, 91, then knit to Row 110.

ROWS 0 to 8: Knit even.

Cast on 134 sts. and work stockinette st.

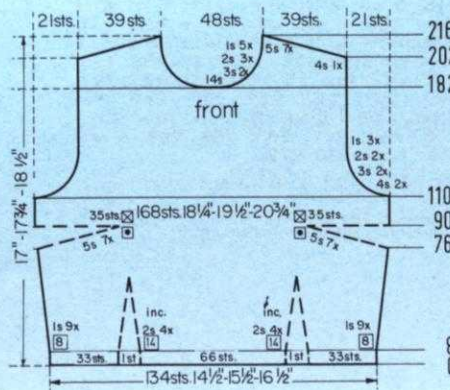

Continued on page 26

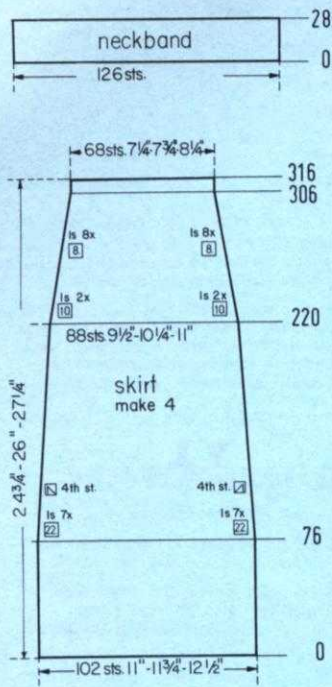

Cast on 126 sts. and work 28 rows stockinette st., then bind off all sts.

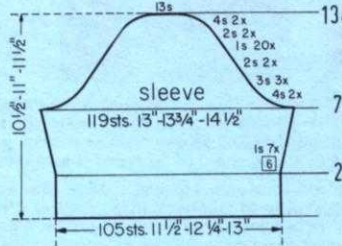

ON CAM BOX SIDE, bind off 4 sts. after Rows 72, 73, 74, 75; 2 sts. after Rows 76, 77, 78, 79, 80, 81; 2 sts. after Rows 82, 83, 84, 85. ON EACH SIDE, hang the 1st st. onto the 2nd st. after Rows 86, 88, 90, 92, 94, 96, 98, 100, 102, 104, 106, 108, 110, 112, 114, 116, 118, 120, 122, 124. ON CAM BOX SIDE, bind off 2 sts. after Rows 126, 127, 128, 129; 4 sts. after Rows 130, 131, 132, 133; 13 sts. after Row 134.

ON EACH SIDE, increase 1 st. after Rows 28, 34, 40, 46, 52, 58, 64, then knit to Row 72.

ROWS 0 to 28: Knit even.

Cast on 105 sts. and work stockinette st.

Work 3 more sections the same.

ON EACH SIDE, decrease 1 st. after Rows 76, 98, 120, 142, 164, 186, 208, 230, 240, 250, 258, 266, 274, 282, 290, 298, 306, then knit to Row 316 and bind off the remaining 68 sts.

ROWS 0 to 76: Knit even.

Cast on 102 sts. and work stockinette st.

HP 3655

| SIZE: | 38 (Chest 37"-38") | 40 (Chest 39"-40") | 42 (Chest 41"-42") |
|---------------|---|------------------------------------|------------------------------------|
| YARN: | Subita Crepe 2 x 3 | Regia | Crocus Crepe |
| 50 gr. BALLS: | | | |
| Pullover: | 10 Color 1 | 12 Color 1 | 15 Color 1 |
| Bolero: | 3 Color 2 | 4 Color 2 | 6 Color 2 |
| TENSION: | 4 to 6 | 5 to 7 | 6 to 8 |
| GAUGE: | 2" Ribbing: 19 sts. 24 rows Pattern: 16 sts. 35 rows | 18 sts. 23 rows 15 sts. 33 rows | 17 sts. 22 rows 14 sts. 31 rows |

The instructions are the same for all sizes. PATTERN: PULLOVER: Knit 1, Purl 3, Ribbing (1 st. on the ribber and 3 sts. on the main machine) according to Line Drawing 1. EDGES: K1, P1, Ribbing. BOLERO: Holding Position Design according to Line Drawing 2. Use Wheel No. W3 and push in the right Needle Retractor Button. INCREASES: Place the end st. from the row below onto the next empty needle. DECREASES: Hang the 1st st. onto the 2nd st. When working the Pullover, transfer the ribber sts. to the main machine before putting the appropriate needles into hold. Bind off all bands the crochet method for ribbing.

FINISHING: Block all sections. (Dampen only, do not iron). PULLOVER: Join front and back section at sides and shoulders. Sew the sleeves together and set in. Join short ends of the collar, then sew 1 edge of collar to inside and 1 edge to outside of neckline. BOLERO: Join back and front sections at sides and shoulders. Join the proper band sections, then bind the armhole edges and all edges of bolero.

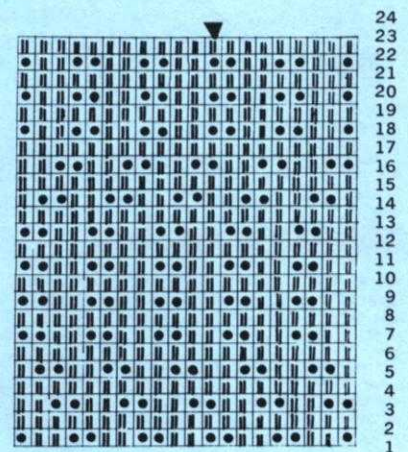

Work the second front section with reverse shapings. Cast on the regular way, then knit 1 row in PATTERN to the left side, turn the Row Counter back to 0 and follow the instructions as written. (Cam Box will be on the LEFT side at even numbered rows).

ON CAM BOX SIDE, bind off 5 sts. after Rows 92, 96 (EVEN ROWS = ARMHOLE SHAPING); 3 sts. after Rows 100, 104; 2 sts. after Rows 108, 112; 3 sts. after Row 113 (ODD ROWS = NECK SHAPING); 2 sts. after Row 116; 3 sts. after Row 117; 1 st. after Row 120; 2 sts. after Row 121; 1 st. after Row 124; 2 sts. after Row 125; 1 st. after Rows 128, 129, 132, 133, 136, 137, 141, 145, 153, 161, 169, 177, 187, 197, 207, 217, 227, 237, 247. For SHOULDER bind off 3 sts. after Rows 258, 260, 262, 264, 266, 268; 4 sts. after Rows 270, 272.

ROWS 0 to 92: Knit even.

Cast on 79 sts. with color 2 and work the Holding Position Design.

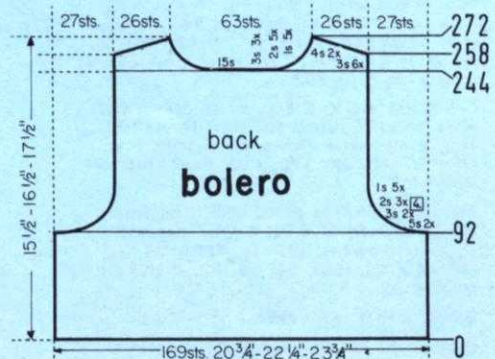
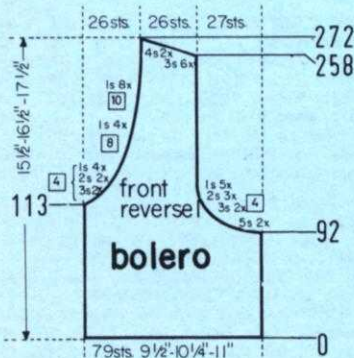

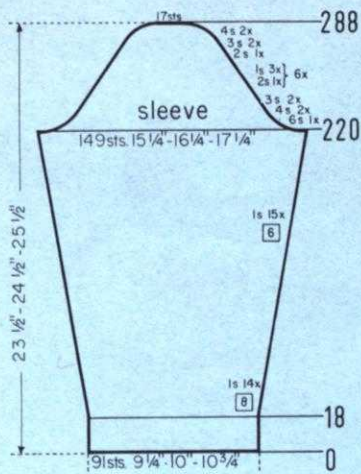

ON CAM BOX SIDE, bind off 6 sts. after Rows 220, 221; 4 sts. after Rows 222, 223, 224, 225; 3 sts. after Rows 226, 227, 228, 229; 2 sts. after Rows 230, 231; 1 st. after Rows 232, 233, 234, 235, 236, 237; 2 sts. after Rows 238, 239; 1 st. after Rows 240, 241, 242, 243, 244, 245; 2 sts. after Rows 246, 247; 1 st. after Rows 248, 249, 250, 251, 252, 253; 2 sts. after Rows 254, 255; 1 st. after Rows 256, 257, 258, 259, 260, 261; 2 sts. after Rows 262, 263; 1 st. after Rows 264, 265, 266, 267, 268, 269; 2 sts. after Rows 270, 271; 1 st. after Rows 272, 273, 274, 275, 276, 277; 2 sts. after Rows 278, 279; 3 sts. after Rows 280, 281, 282, 283; 4 sts. after Rows 284, 285, 286, 287; 17 sts. after Row 288.

ON EACH SIDE, increase 1 st. after Rows 18, 26, 34, 42, 50, 58, 66, 74, 82, 90, 98, 106, 114, 122, 130, 136, 142, 148, 154, 160, 166, 172, 178, 184, 190, 196, 202, 208, 214, then knit to Row 220.

ROWS 0 to 18: Knit even.

Cast on 91 sts. with color 1 and work Knit 1, Purl 3, Ribbing.

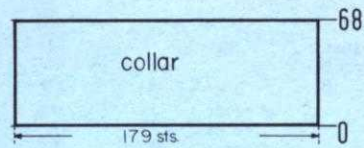

Cast on 179 sts. with color 1 and work 68 rows K1, P1, Ribbing, then bind off all sts.

Bring the needles on the left side into working position, knit 1 row in PATTERN to the left side, turn the Row Counter back to 272 and complete the left half. Follow the instructions from*.

*ON CAM BOX SIDE, bind off 4 sts. after Rows 273, 275; 3 sts. after Rows 277, 279; 2 sts. after Rows 281, 283; 1 st. after Rows 285, 287, 289, 291, 293. For SHOULDER bind off 4 sts. after Rows 298, 300, 302, 304; 5 sts. after Rows 306, 308, 310, 312, 314, 316.

Work the front section the same as the back section to ROW 272, then bind off the center 15 sts., put the needles on the left side into holding position and complete the right half first.

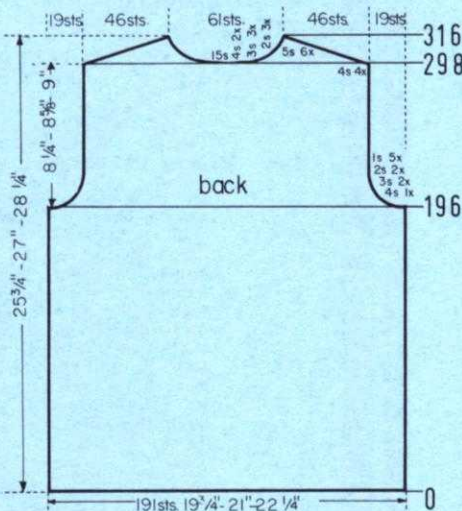
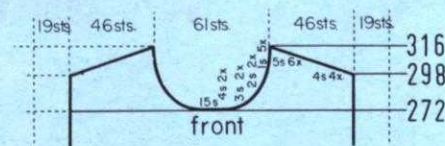

Bring the needles on the left side into working position, knit 1 row in PATTERN to the left side, turn the Row Counter back to 298 and complete the left half. Follow the instructions from*.

*ON CAM BOX SIDE, bind off 4 sts. after Rows 298 (EVEN ROWS = SHOULDER SHAPING), 300, 301, 302; 3 sts. after Row 303; 4 sts. after Row 304; 3 sts. after Row 305; 5 sts. after Row 306; 3 sts. after Row 307; 5 sts. after Row 308; 2 sts. after Row 309; 5 sts. after Row 310; 2 sts. after Row 311; 5 sts. after Row 312; 2 sts. after Row 313; 5 sts. after Row 314, 316.

ON CAM BOX SIDE, bind off 4 sts. after Rows 196, 197; 3 sts. after Rows 198, 199, 200, 201; 2 sts. after Rows 202, 203, 204, 205; 1 st. after Rows 206, 207, 208, 209, 210, 211, 212, 213, 214, 215, then knit to Row 298, bind off the center 15 sts., put the needles on the left side into holding position and complete the right half first. (For the FRONT Section knit to ROW 272).

ROWS 0 to 196: Knit even.

Cast on 191 sts. with color 1 and work Knit 1, Purl 3, Ribbing.

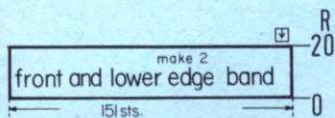

Cast on 151 sts. and work 20 rows K1, P1, Ribbing, then bind off all sts.

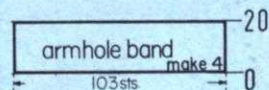

Cast on 103 sts. and work 20 rows K1, P1, Ribbing, then bind off all sts.

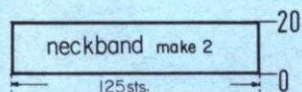

Cast on 125 sts. and work 20 rows K1, P1, Ribbing, then bind off all sts.

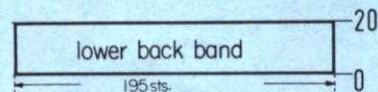

Cast on 195 sts. and work 20 rows K1, P1, Ribbing, then bind off all sts.

Bring the needles on the left side into working position, knit 1 row in PATTERN to the left side, turn the Row Counter back to 244 and complete the left half. Follow the instructions from*.

*ON CAM BOX SIDE, bind off 3 sts. after Rows 245, 247, 249 (ODD ROWS = NECK SHAPING); 2 sts. after Rows 251, 253, 255, 257; 3 sts. after Row 258 (EVEN ROWS = SHOULDER SHAPING); 2 sts. after Row 259; 3 sts. after Row 260; 1 st. after Row 261; 3 sts. after Row 262; 1 st. after Row 263; 3 sts. after Row 264; 1 st. after Row 265; 3 sts. after Row 266; 1 st. after Row 267; 3 sts. after Row 268; 1 st. after Row 269; 4 sts. after Rows 270, 272.

ON CAM BOX SIDE, bind off 5 sts. after Rows 92, 93, 96, 97; 3 sts. after Rows 100, 101, 104, 105; 2 sts. after Rows 108, 109, 112, 113, 116, 117; 1 st. after Rows 120, 121, 124, 125, 128, 129, 132, 133, 136, 137, then knit to Row 244, bind off the center 15 sts., put the needles on the left side into holding position and complete the right half first.

ROWS 0 to 92: Knit even.

Cast on 169 sts. with color 2 and work the Holding Position Design.

bolero

CANADIAN READERS

Please note that KNITKING dealers based in the U.S.A. are unable to sell machines and accessories to residents of Canada. They are also unable to sell parts and service. Would all Canadian readers please contact the following appointed KNITKING dealer.

KNITKING Sales and Service
2243 Danforth Ave.
Toronto 13, Ontario

KG 1955

| SIZE: | Bust or Chest | 32"-33" | 34"-35" | 37"-38" |
|---------------|---------------|--|--|--|
| YARN: | | Crocus Crepe | Amore | Set 70 Crepe |
| 50 gr. BALLS: | | 4 color 1 1 color 2 1 color 3 1 color 4 | 3 color 1 1 color 2 1 color 3 1 color 4 | 5 color 1 2 color 2 1 color 3 1 color 4 |
| TENSION: | | 5 to 7 | 7 to 9 | 7 to 9 |
| GAUGE: | 2" | 16 sts. 23 rows | 15 sts. 23 rows | 14 sts. 21 rows |

The instructions are the same for all sizes. Pattern: Stockinette Stitch with color changes. EDGES: K1, P1, Ribbing. Bind off all edges the crochet method for ribbing.

FINISHING: Block all sections. Join front and back section at sides and shoulders. Join the armhole bands, then the neckband sections at short ends, then sew the bands in place.

Back Section

Cast on 131 sts. with color 1 and work K1, P1, Ribbing. Rows 0 to 20: Knit even, then change to stockinette st. ON EACH SIDE, increase 1 st. after Rows 20, 34, 48, 62, 76, 90, then knit to Row 102 and change to color 2.

ON CAM BOX SIDE, bind off 6 sts. after Rows 102, 103; 3 sts. after Rows 104, 105, 106, 107; 2 sts. after Rows 108, 109, 110, 111, 112, 113; 1 st. after Rows 114, 115, 116, 117, 118, 119, then knit to Row 134 and change to color 3. Knit to Row 166 and change to color 4, then knit to Row 180, bind off the center 23 sts., put the needles on the left side into holding position and complete the right half first.

ON CAM BOX SIDE, bind off 3 sts. after Rows 181, 183, 185; 2 sts. after Rows 187, 189, 191; 1 st. after Rows 193, 195, 197, 199, 201, 203, then knit to Row 208 and bind off the 18 Shoulder sts. Move the Cam Box to the left side, turn the Row Counter back to 180 and complete the left half. Follow the instructions from.

FRONT SECTION

Work the front section the same as the back section to ROW 134, change to Color 3, bind off the center 23 sts., put the needles on the left side into holding position and complete the right half first.

*ON CAM BOX SIDE, bind off 3 sts. after Rows 135, 137, 139; 2 sts. after Rows 141, 143, 145; 1 st. after Rows 147, 149, 151, 153, 155, 157, then knit to Row 166, change to color 4. Knit even to Row 208, then bind off the 18 Shoulder sts.

Move the Cam Box to the left side, turn the Row Counter back to 134 and complete the left half. Follow the instructions from*.

BACK NECKBAND: Cast on 85 sts. with color 1 and work 12 rows K1, P1, Ribbing.

FRONT NECKBAND: Cast on 143 sts. with color 1 and work 12 rows K1, P1, Ribbing.

ARMHOLE BANDS: Cast on 171 sts. with color 1 and work 12 rows K1, P1, Ribbing.

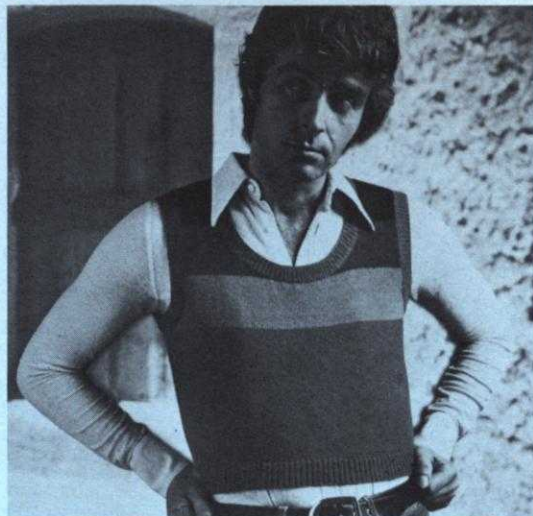

KG 1956

SKI HAT

MATERIAL: KNITKING Flamingo Dralon, 50gr. balls in 3 colors. 2 Color 1, 1 Color 2, 1 Color 3. TENSION 7 to 9. GAUGE: 14 sts. 19 Rows = 2.

Cast on 117 sts. with Color 3. Knit 18 Rows EACH Colors 3, 2. 60 Rows, Color 1; 8 Rows, Color 2; 6 Rows EACH, Colors 3, 1, 2; 4 Rows EACH, Colors 3, 1, 2; 2 Rows EACH, Colors 3, 1, 2, 3 (Row 142)

Hang the hem by picking up the cast on sts. and hang them back onto the machine behind the latches. Turn Tension Dial 1 number higher, put COUNTER AT 0 and with Color 1, knit 1 row, turn the Tension back to original number. Bring the 2nd and 3rd and every following 2nd and 3rd needle into holding position. Transfer each of the sts. from the holding position needles to the needles in work, first to the right and then to the left so that there are 3 sts. on each of the working needles with 2 empty needles between with the exception of the two end needles. The end needle on the right will have 2 sts. on it; the end needle on the left will have 1 st. and you must move this one over (out) so that there are 2 empty needles. Put all the empty needles into the out of work position. With Color 1 knit 1 row over the 40 needles, then work the TAIL. (Row 2).

Knit 10 Rows EACH, Colors 1, 2, 3. 1 (Row 42); 8 Rows EACH, Colors 2, 3; 10 Rows Color 1 (Row 68); 8 Rows EACH, Colors 2, 3, 1 (Row 92); 6 Rows EACH, Colors 2, 3 (Row 104); 8 Rows Color 1; 6 Rows EACH, Colors 2, 3, 1 (Row 150); 4 Rows EACH, Colors 2, 3; 6 Rows Color 1 (Row 164); 4 Rows EACH, Colors 2, 3 (Row 172); 6 Rows Color 1; 4 Rows EACH, Colors 2, 3, 1; 2 Rows EACH, Colors 2, 3; 4 Rows Color 1 (Row 184); 2 Rows EACH, Colors 2, 3; 4 Rows Color 1 (Row 192).

Take the sts. off onto the end of yarn. Do not pull up until you weave the seam.

FINISHING: Weave the lining, then the hat and long tail. Pull up the top of tail and fasten securely. Make large Pom-pom and sew to top of tail.



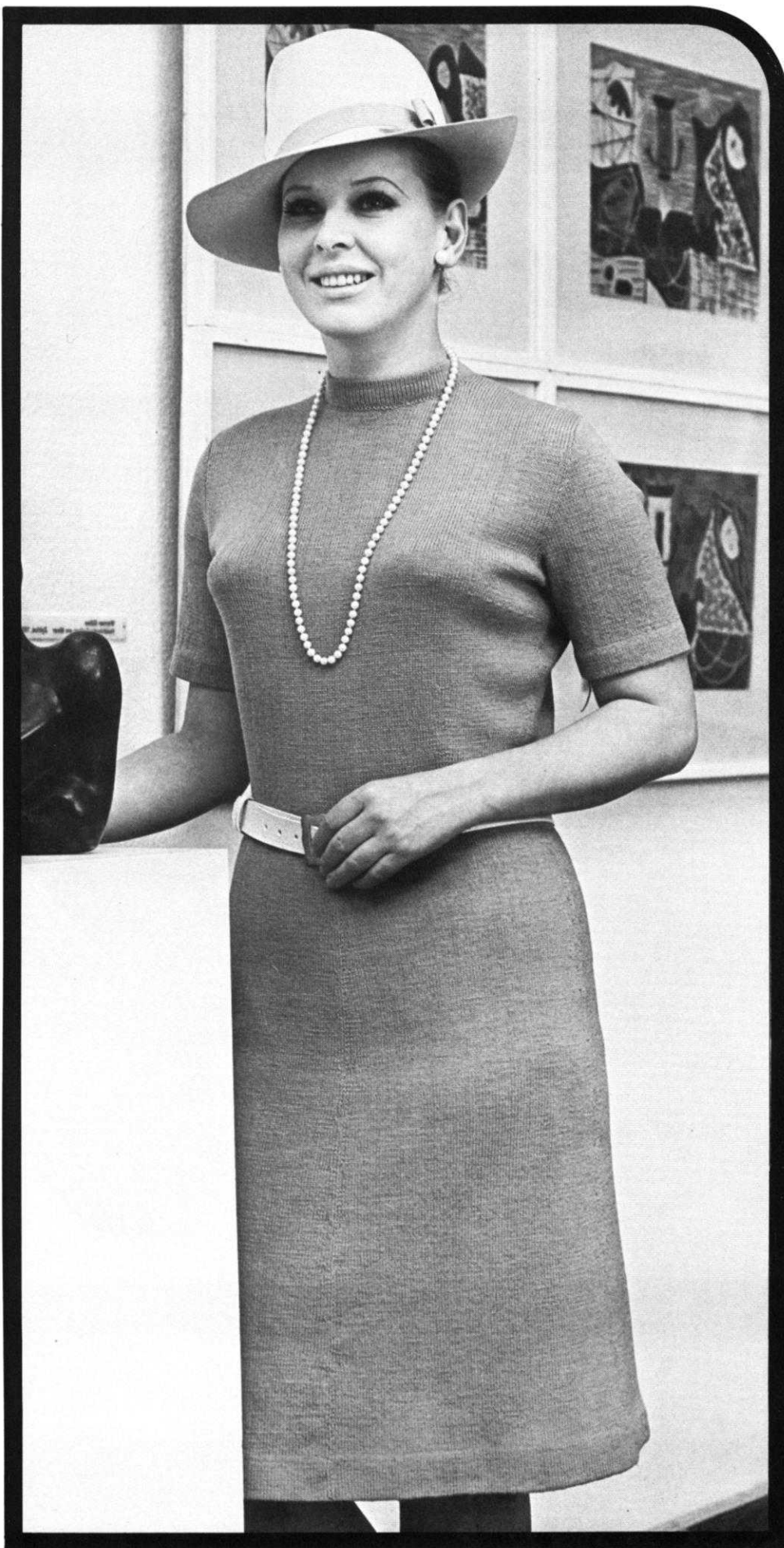

DK 8137 — A basic Dress is easy to knit in Stockinette stitch and is the perfect foil for your favorite jewelry. Knit it in a jiffy too. Use KNITKING Subita Crepe 2 x 3 for a Size 12; Beatrice for Size 14; Regia for Size 16.





DV 8098 — Sheer luxury . . . Pamper yourself with a lovely easy to knit Bed Jacket. Full sleeves are pulled up at the wrist with elastic through the hem casing. The Yoke is a holding position Design. Sizes, Small; Medium; Large . . . all knitted with easy care KNITKING Flamingo Dralon.

KK 5380 — Keep your baby cozy and warm in a bright 2-piece Play Suit. The Coveralls are striped on the lower leg sections as well as on the top, with buttons at the shoulders. The Pullover is knitted in one color. Use machine wash, machine dry, KNITKING Allegro. Size 3 to 9 months.







DV 8098 — Sheer luxury . . . Pamper yourself with a lovely easy to knit Bed Jacket. Full sleeves are pulled up at the wrist with elastic through the hem casing. The Yoke is a holding position Design. Sizes, Small; Medium; Large . . . all knitted with easy care **KNITKING Flamingo Dralon**.

KK 5380 — Keep your baby cozy and warm in a bright 2-piece Play Suit. The Coveralls are striped on the lower leg sections as well as on the top, with buttons at the shoulders. The Pullover is knitted in one color. Use machine wash, machine dry, **KNITKING Allegro**. Size 3 to 9 months.



HP 3655 — This great Pullover and Bolero team up for your man . . . Knit the Pullover in a 3 x 1 Rib, the Bolero in a holding position Design. Complete the

“now look” with a wide leather Belt. Size 38 is knitted with KNITKING Subita 2 x 3; Size 40, Regia; Size 42, Crocus Crepe.



DK 8005 — Winter warm-up . . . in a dress that is knitted in easy stockinette stitch with widely spaced stripes. Pull up the attached Hood when you are outside . . . when indoors, you can drop it down to form a Collar. Size 10 is knitted with KNITKING Subita 2 x 3; Size 12, Regia; Size 16, Amore.







DV 8102 — MOHANA - KNITKING'S elegant Mohair is knitted into a lovely feminine Bed-jacket. Stockinette stitch combined with an Eyelet Design is made up to be worn on the Purl side. Trim the Bedjacket with velvet Ribbon. Size 10/12 and 14/16.

KK 5378 — Knit your child a two-piece Play Suit . . . The top and the Pants are knitted in a Holding Position Design with the Yoke in a Ribbed Stitch. For the 1 to 2 year old. KNITKING Regia is the yarn.

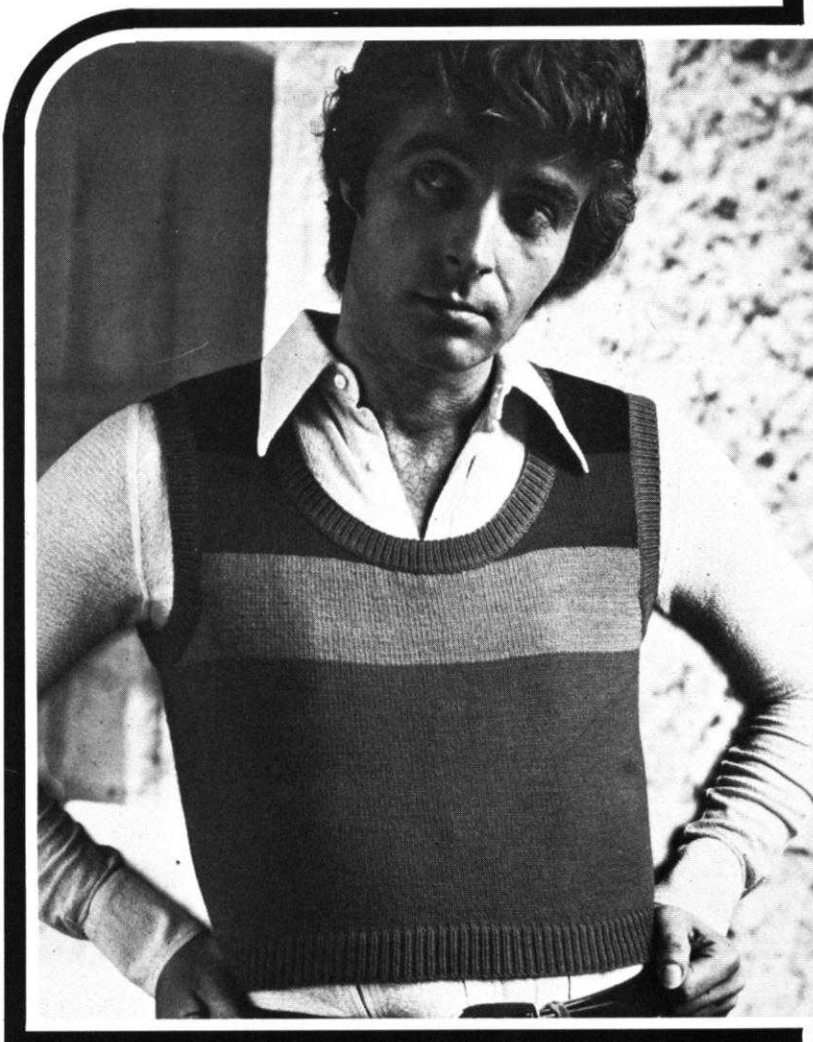

KG 1955 — Requests have been coming into our office for a SHRINK . . . so now you can whip one up for either Girl or Boy, Man or Women. Knit it with KNITKING Crocus Crepe, Amore or Set 70 Crepe.



KG 1956 — Fly the Ski Slopes . . . A snug fitting Hat with a long flying tail is just what the Ski enthusiast ordered . . . or wrap it around your neck for any winter sport. Knit it with KNITKING Flamingo Dralon in 3 colors.

KNITKING NEWS

January/February, 1973

WHIZ KING PATTERN READER

Did you notice the Advertisement on the inside Front Cover of this issue... and did you read the Editorial on the first page...? We want to be sure that you know about the remarkable new accessory KNITKING is introducing and that you understand the complete Charting Service we are offering with it.

The WHIZ KING PATTERN READER is designed to enable you to knit the garment of your choice in the size you desire... All the preliminary work... the designing of the garments and the drawing

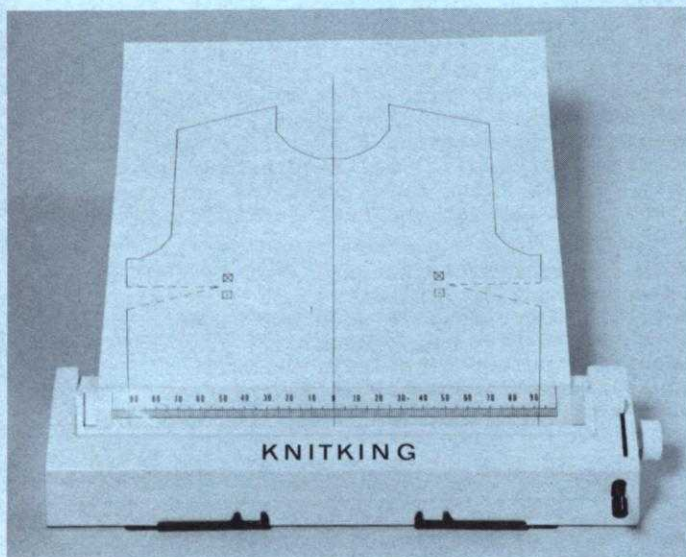

of the Charts in various sizes is done by KNITKING... all you have to do (once you own a WHIZ KING PATTERN READER) is to feed a Chart into the Reader and knit...! You read the Chart as it automatically revolves by following the outline of your garment sections... You make your increases and decreases, darts and shapings, etc., on the correct rows with complete accuracy and without reference to written instructions and without even using your Row Counter.

Knitting with a WHIZ KING PATTERN READER is so incredibly simple that once you use it, you will never want to return to the old methods... Your WHIZ KING will speed the completion of garments tremendously because once you start, you will not have to repeatedly refer to written instructions... You will not need to take your eyes off your knitting machine until the completion of each garment section... and you can be confident that all garment sections will fit together when completed.

The designing of a simple uncomplicated, yet versatile Pattern Reading Device (like the designing of a KNITKING, fully versatile, easy to operate one button knitting machine) was a project that challenged the skill and ingenuity of our top notch development staff working in collaboration with our garment Designers and expert Knitters... Several prototype machines were made and rejected before tooling up to proceed with WHIZ KING and technical experts from the world wide distribution

center of KNITKING machines were involved in its development... It was even necessary to design a completely new graph paper on which to draw original Charts... Traditional geometric squares are not satisfactory because a stitch is almost always greater in width than in height (for example, a yarn may produce 8 stitches and 11 rows to an inch) so, we designed a special graph paper with rectangles instead of squares with each rectangle representing a stitch... It took a Computer to decide the perfect shape and size of each rectangle... and the Pattern Reader had to be synchronized so that every time you push your Cam Box across your machine, your Pattern Chart revolves exactly one row, not a fraction more or a fraction less

We could get carried away and elaborate more on the skill and know how that has gone into the development of the WHIZ KING PATTERN READER, but we believe that most knitting machine owners will be interested mainly in its efficiency and simplicity of operation... As we said in our Editorial, we believe that the WHIZ KING PATTERN READER will mark the greatest advance in home knitting machine operation since the introduction of the first KNITKING over 25 years ago.

Order your WHIZ KING today and if you intend to use it on a knitting machine of a brand other than KNITKING, be sure to tell us the brand and Model Number.

PRACTICAL KNITTING HINT

The Skirt for Pattern No. DK 8107 in this issue, is made in sections that are woven together, then a slip stitch crochet is worked over the center stitch of each panel so that pleats will fall into place. We have taken copy from our "Practical Knitting Hints Book" to show you exactly how this is accomplished.

Slip Stitch Crochet for Creases and Pleats

Oftentimes instructions for patterns tell you to slip stitch crochet up or down on knit stitches to create a definite fold line. In order to do this, fold your knitting with the stitches that are to be crocheted off as your fold line. First form a loop on your crochet hook. Now insert the crochet hook through your knitting as shown in Illustration 1. Catch the yarn and pull this loop through

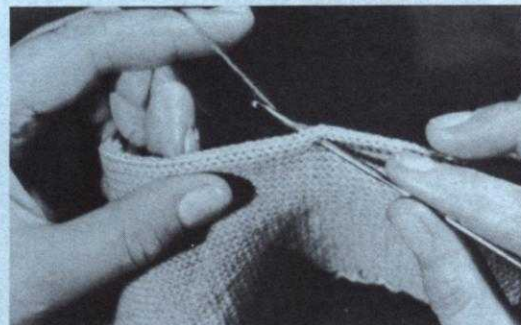

Illus. 1

your knitting and through the loop on the crochet hook. Continue inserting the hook through each row of the knitting, catching the yarn and pulling the loop through the knitting and through the loop on the hook. Crochet stitches formed in this manner will conform to the knitted stitches as shown in Illustration 2. We recommend using a crochet hook that is not too large,

and is of suitable size according to the yarn you are using. Pull the yarn firmly each time a stitch has been formed, otherwise the fold or crease line will expand and will be longer than the rest of your garment. Depending on how pronounced you want the fold line to be, a width of 1, 2 or 3 stitches can be crocheted off. The width most suitable can be determined when the stitch gauge is made.

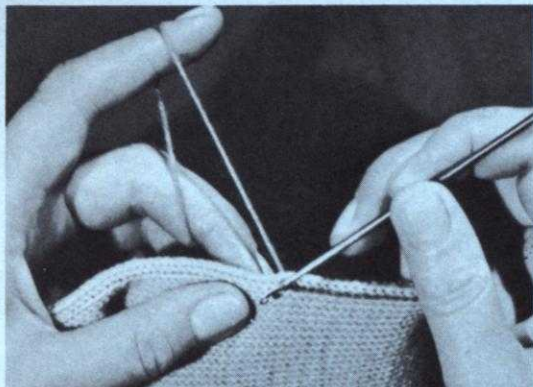

Illus. 2

Stitches that are to be crocheted off will obviously make a difference by that number of stitches in the width of the garment, especially if many fold lines are to be made as in a pleated skirt. These stitches have to be considered when figuring the pattern. Crocheted fold lines are also very attractive on trouser creases and give a very nice accent to skirts.

CORRECTION TO COPY in NOV/DEC KNITTING MAGAZINE

An error occurred in the setting of the Captions to the pictures on pages 6 and 7 of the November, December 1972 KNITTING MAGAZINE and the Pattern Numbers were over the wrong pictures. The Pattern Numbers and instructions on page 16 are correct however... Sorry if we confused you and thanks to the readers who pointed out the error...

OUR READERS WRITE

We still receive letters asking about SHORT ROWS and how to knit them on a machine... There are different methods for knitting Short Rows... and the method you use should depend on where the Short Rows are to be placed... and on WHAT....

METHOD No. 1: This is the first and BASIC type of Short Rows... the one you will use for Bust Darts; to shape the lower section of an "A" line Skirt; for shaping Armholes and Necklines... in fact, it can be used for ALL Short Rowing... using any number of stitches... anyplace... on anything... for it barely shows in your knitting... leaves no holes and is the best all around method. It takes a bit more time because you must wrap the INSIDE NEEDLE in holding position on every row. It is ALWAYS worked by placing a specified number of needles OPPOSITE CAM BOX into holding position for a specified number of rows and then bringing a specified number of needles OPPOSITE CAM BOX back into working position. If you are not familiar with Short Rows, and their variations... make some practice samples of each type and keep them for future reference. Use 3-ply sport weight yarn for all samples and Tension 5 or 6.

1. BUST DARTS: Cast on 50 sts. Knit 20 rows. Work Short Rows: ON OPPOSITE SIDE OF CAM BOX, put 5 needles into holding position, knit across, then bring the yarn UNDER the inside needle in holding position so that the yarn will go over the shank of the needle when you knit the next row. ON OPPOSITE SIDE OF CAM BOX, put 5 needles into holding position, knit across, bring the yarn under the INSIDE NEEDLE as you did before and continue to bring 5 needles OPPOSITE CAM BOX into holding position, knit across, wrap yarn...until you have 20 needles ON EACH SIDE in holding po-

sition. Now bring ALL the needles back into working position before knitting the next 2 rows. Knit 20 rows, bind off. Pull your knitting into shape so that you can see the sample BUST DART. You will note that there are MORE ROWS in the CENTER part of the knitting - which is exactly what you need for the bust shaping of a garment. If your garment is to be worn on the PURL SIDE, when wrapping the inside needle in holding position, lift the stitch with a transfer tool from that inside needle and wrap the yarn around the shank of the needle, then put the stitch back on to needle - be sure to leave it in holding position. This places the wrapping in BACK on the knit side so it will not show on the Purl side.

In the November/December issue of KNITTING MAGAZINE, we told you about using Short Rows for the shaping of armholes and necklines.... so get out your copy and refresh your mind.

2. SHAPING A HEEL or TOE: Cast on 35 sts. Knit 20 rows. If you made the sample swatch above, you already know about wrapping the yarn around the inside needle, so we won't repeat the instructions for doing it here... just remember to wrap the yarn each time. ON OPPOSITE SIDE OF CAM BOX, put 1 needle into holding position before knitting the next 24 rows (11 sts. left in work) - wrap yarn each time. Now ON OPPOSITE SIDE OF CAM BOX, bring back into working position, 1 needle before knitting the next 24 rows (remember to wrap the yarn)... All needles are now in work. Knit 20 rows, bind off. Pull the knitting into shape, and look at the heel (or toe) you have just knitted.

When you want HOLES as part of a Design, such as in an Afghan, or Pillow... this same method for knitting Short Rows is used but without wrapping yarn around the inside needle... just bring the specified number of needles OPPOSITE CAM BOX into holding position before knitting each row, then return them as specified...no wrapping of any kind.

3. SHAPING THE BOTTOM OF AN "A" LINE SKIRT OR DRESS.

When knitting an "A" line Skirt, always knit the under side of HEM, then the specified ROWS for hem before shaping the sides. If you like, you can knit the UNDERSIDE of a hem at one tension lower than the garment tension. Cast on 50 sts. Knit 30 rows. Hang the hem by picking up each cast on stitch and place the sts. onto the needles behind the latches. Knit 1 row using 1 or 2 tensions higher than garment tension, turn the tension back to garment tension and knit 1 row. ON OPPOSITE SIDE OF CAM BOX, put 16 needles into holding position before knitting the next 2 rows (wrap yarn each time). ON OPPOSITE SIDE OF CAM BOX, bring back into working position 4 needles before knitting the next 8 rows (wrap yarn). Knit 20 rows, bind off. Remember this is only a sample swatch... your Skirt or Dress will have far more stitches and the number of stitches and rows used for shaping the sides will be more. Pull sample into shape and you will see the "A" line is SHORTER on the sides than in the middle and the shaping goes from the center OUT and UP which is a different shaping than the Bust Dart. If you do not want a hung hem... cast on, then start the Short Rows immediately, and hem up later.

There are many variations of spacing of stitches. The number of needles you put into holding position and the number you will bring back into working position depend on what you are knitting, and the shaping you wish.

Watch for the next issue of KNITTING MAGAZINE Practical Knitting Hint... In it we will tell you two alternate methods.

NOTES TO KNIT BY . . .

STITCH AND ROW GAUGE

KNIT A SAMPLE SWATCH . . . before you begin to knit any garment . . . for this is the MOST IMPORTANT STEP toward the correct size and the proper fit of any garment you wish to make. You MUST use the SAME YARN for your sample swatch that you will use to knit your garment and your sample swatch must be knitted large enough and using several different tension numbers on your machine. When you have done this, then you can determine the number of stitches and the number of rows in a two-inch measure. KNITTING MAGAZINE PATTERNS give you 3 tensions to try and one of them should give you the correct stitch and row gauge if you are using the yarn we recommend or a similar weight yarn. Here is the way to make your sample swatch.

Cast on over a sufficient number of needles to produce a swatch at least 4 inches wide. (If the pattern calls for 16 stitches to 2", then $16 \times 2 = 32$ stitches to cast on). Now knit 4 inches of rows at the first suggested tension number. (If the pattern calls for 22 rows to 2", $22 \times 2 = 44$ rows to knit). Knit 2 rows using a contrast color, change to the next higher tension and with garment yarn knit another 4", knit 2 rows with contrast color, change to the 3rd higher tension and knit another 4" and then bind off.



Roll the swatch into a cylinder over its length and pull on both ends, unroll it and stretch it diagonally by pulling on the four corners. Allow the swatch to rest and settle (preferably overnight) and then using a stitch gauge or a ruler, count the number of stitches over a 2" width, then the number of rows over a 2" length in EACH of the 3 tensions. Select the tension number that produces the stitches and rows called for in the pattern. If none of them are correct, you are most likely using the wrong weight of yarn.



READING OF CHARTS

You will notice the instructions start at the bottom of the Chart and work UP. Follow the charts exactly as written and providing your sample stitch and row gauge is correct, your garment will come out the right size. Please remember that the section of garment as it is knitted on the machine, faces the same way as the Charts are in this magazine. Where two front pieces are needed, (or any other part of a garment that needs two sections) only one section is normally shown and the second section is usually made with reverse shaping. Set in sleeves are usually identical, but raglan sleeves have to be knitted with reverse shaping for the second sleeve.

READING OF SYMBOLS

To simplify Pattern Knitting, we use Symbols in the Line Drawings and the Chart Diagrams. In the Line Drawings the symbols are shown and are to be read as you look at them while knitting a garment. For instance, if



a Purl stitch faces you, the Purl stitch Symbol  is shown; if a knit stitch faces you (as when using the Ribber) then this Symbol  is shown. The Symbol  at the top of the Line Drawing is the center of the garment section and you use this as a guide for setting up the needles.

The following Symbols    are used for Eyelet Designs in the Line Drawings and also for Full Fashion shaping on the Charts. The Line Drawings have row numbers on the right side. Missing Row numbers are always knitted straight or plain.

In Holding Position Designs  selected needles are pushed into holding position for the stated number of rows. The numbers of rows appear at the right of the Line Drawings; Example: 1-4 means knit Rows 1 to 4; 5 to 7 means knit Rows 5 to 7, etc. This same Symbol is also shown on the Charts and is used for putting needles into holding position for Short Rows. The

Symbol  on the Charts is used to put needles back into working position when knitting Short Rows.

A number in a box stands for the number of rows to be knitted between shapings. Make shaping first, then knit the necessary number of rows. If for instance it reads:

1 st. 8 x

 1 st. 10 x



As you will be reading the instructions from the bottom up, here is the way you will follow them: . . . Decrease or increase (depending on the direction of the garment outline) 1 st. at the row where the shaping begins, then knit 8 rows, make the next decrease, then knit 8 rows, until you have decreased (or increased) 1 st. 10 x and you have knitted 8 rows after each decrease (or increase) (1 st. 10 x +8 rows 10 x). Now begin the first decrease (or increase) for the shaping (which has to be made 8 x) in every 6th row. Decrease (or increase) 1 st. first, then knit 6 rows until you have decreased 1 st. 6 x and after each decrease (or increase) have knitted 6 rows (1 st. 8 x + 6 rows 8 x).

Where shapings are given without a boxed number as on most armholes, necklines, etc., make the shapings on every second row (on each side of course).

(See below for more Pattern Stitch Symbols.)

PATTERN STITCH SYMBOLS

 = knit stitch

 = purl stitch

 = empty needle (leave in working position)

 = needle not used (in the out of work position)

 = needle in the holding position

 = Needles back into working position.

 = 2 stitches on 1 needle — either transferred from the right side or the left side, then put the needle into holding position

 = needle holding 2 stitches. Stitch has been transferred from the LEFT

 = needle holding 2 stitches. Stitch has been transferred from the RIGHT

 = 3 stitches on 1 needle. The 1st and 3rd stitch in a group of 3 needles has been hung on the 2nd or center needle.

 = Center of Garment Section.

 = Number of rows to be knitted between shapings.

The diagrams (Line Drawings) for pattern work are followed just as they are shown and are to be read as you look at them while knitting the garment.

open darts



closed darts



