

knitking

magazine

sept./oct. '74



Another first from Knitking!!!

THE ~~WHIZ KING~~ PATTERN READER with complete Charting Service

- With WHIZ KING you know exactly what to do without reference to written instructions.
- With WHIZ KING you no longer have to count rows . . . Your Pattern Chart turns automatically as you knit.
- With WHIZ KING you can knit even the most intricate patterns easily and speedily.
- With a WHIZ KING Pattern Reader, even the complete newcomer to machine knitting can immediately knit garments.
- With WHIZ KING, Charts are available from KNITKING MAGAZINE Patterns in the size of your choice.

PRICE: 59.50 Complete with instructions, practice Charts and illustrations of 50 complete Patterns for the entire family. (California residents add Sales Tax)
Shipping costs \$2.50.

ORDER DIRECT FROM KNITKING 1128 CRENSHAW BLVD. • LOS ANGELES, CALIFORNIA 90019

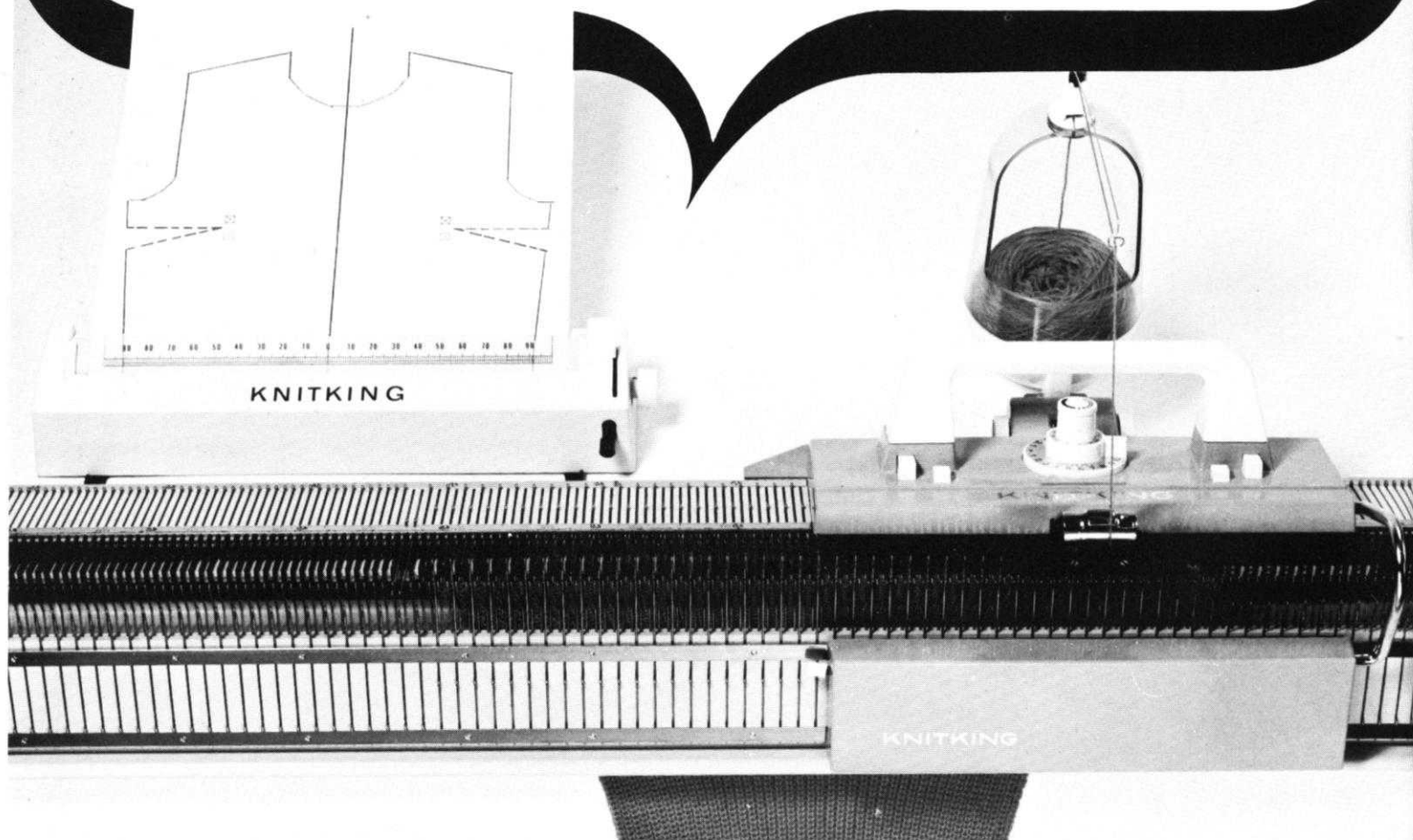

editorial

MILENA BRABCOVA STRASOVA . . . Isn't that a lovely name? It rolls off the tongue like poetry . . . Milena is a celebrated European Fashion Designer who specializes in knitted garments and who uses KNITKING machines exclusively in her design studio . . . She started as a student of art and later discovered a natural talent for creating and designing clothes . . . Fashion Shows exhibiting her splendid designs have taken place in many European countries including Russia . . .

Milena is an artist whose artistry is reflected in the excellent style of her designing . . . She can truly be called a "Classicist" as her designs are classic and elegant and she uses only top quality materials . . . Milena's work is, in fact, just perfect for KNITKING MAGAZINE which is why she was commissioned to design an assortment of garments for the first two issues of KNITKING MAGAZINE in its larger format, and we can tell you that the garments appearing in our November/December and January/February issues are marvelous. We know that the majority of our readers will be impressed and we look forward to hearing your comments . . .

There will be twenty-eight pages in FULL COLOR displaying Milena's work in our November/December issue. The models used are glamorous European models and the garments include an assortment of lacy design Dresses, Pantsuits with lacy tops, Capes, Stoles, glamorous full length evening wear, cocktail Dresses, etc., etc. There are also some cute designs for the youngsters and, for the men some up-to-date Pullovers and Sweaters . . . All in all, we know that there will be something for everybody.

SUBSCRIBERS CONTEST

Your response to our Editorial in the July/August KNITKING MAGAZINE has proved very gratifying and we are pleased with the vote of confidence shown by the volume of subscriptions. The contest continues until the end of September, so if you have not sent in your contest card, making you eligible for the many prizes including a first prize of KNITKING MERCHANDISE TO THE VALUE OF \$500.00, second prize of MERCHANDISE TO THE VALUE OF \$200.00, a third prize of \$100.00 plus prizes of cones of the new HEAVENLY YARN, please send in your card now and be sure to retain the stub as every subscriber has an equal chance of winning.

Great things are happening with your publication — KNITKING MAGAZINE and it is your continuing support through the purchase of our merchandise that enables us to continue to provide you with the best of everything in machines, yarns, fashions, etc. . . .

LOS ANGELES COUNTY FAIR

We are once again looking for an excellent response to our beautiful garment display at the Los Angeles County Fair in Pomona, running from September the 13th through the 29th and we hope to meet many old and new friends during that period.

At the time of writing this Editorial, most of the garments for our November/December Magazine are being displayed at a Festival in Germany, but we are anticipating flying them to Los Angeles in time to display some of them at the Fair, so if you live in the Southern California area, please try to get out and see us.

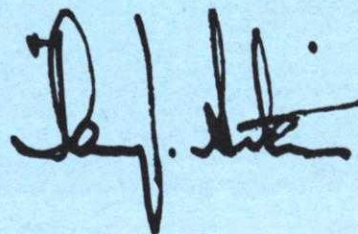

SEPT./OCT. 1974

VOL. 11, No. 1

knitking *magazine*

INDEX	PAGE NO.
DK 8267	Woman's Dress 9
DK 8195	Woman's Jacket and Skirt 10
DP 8175	Woman's Pullover 11
DK 8192	Woman's Dress 12
DK 8353	Woman's Twin Sweater Set 13
HP 3710	Man's Pullover 14
DK 8187	Woman's Pants, Jacket and Pullover . . 16
DK 8343	Woman's Dress and Jacket 18
KG 1984	Blanket and Pillows 20
DK 8172	Woman's Skirt and Jacket 21
KK 5418	Child's Pullover and Vest 22
MK 5503	Girl's Pullover 23
HP 3727	Man's Vest 24
HP 3721	Man's Cardigan 25
DK 8333	Woman's Jacket 26
DK 8334	Woman's Pullover Vest 27
KK 5529	Child's Pullover Vest 28



COVER MODEL DK 8267 — The sparkle of Beatrice Silver enhances an easy to knit dress in Stockinette stitch with a Norwegian border. Design on the skirt section and sleeves made with Beatrice Crepe. Knit it in Sizes 14, 16 and 18.

FASHION FORECAST! . . . Watch for more and more knits designed to wear around the clock . . . any place. With this issue of **KNITTING MAGAZINE**, we are into our 11th year of publication and our plans for future issues grow bigger and more exciting . . . wait and see!

Publisher: **KNITTING CORPORATION**, 1128 Crenshaw Blvd., Los Angeles, Calif. 90019. Telephone: (213) 938-2079. Published bi-monthly. Subscriptions: USA — \$10.00 annually, single copies \$2.00; Canada — \$12.00; other parts of the world — \$15.00. The entire contents of **KNITTING MAGAZINE** are copyright and must not be reproduced in any shape or form without the express permission, in writing of the publisher. © COPYRIGHT 1974 by **KNITTING CORPORATION**.

Printed by William B. Wemyss Printing Associates, Los Angeles, Ca.



NEW VOLUME AVAILABLE NOW

A complete tenth volume of **KNITTING MAGAZINES** with a flexible, transparent plastic cover and specially bound so that it will stay open at any page, is available at the special price of \$7.95 (plus \$1.15 mailing costs).

If purchased separately the magazines would cost a total of \$9.00.

The volume contains over 120 fully illustrated complete stylish patterns for all members of the family together with many valuable, practical knitting hints.

There is a very limited number of these volumes available and it will undoubtedly become a collectors item.

If you already have the entire set it will almost certainly be well thumbed and marked. Why not purchase a perfect mint condition volume for your bookshelf and ready reference at any time.

Place your order today and avoid disappointment. Send it to **KNITTING MAGAZINE, 1128 Crenshaw Boulevard, Los Angeles, California 90019.**

DP 8175 — Terrific Topper! Made to be worn over a Blouse or on its own. Truly a quickie knit, this one is striped — but knit another without the stripes and trim it with sequins, beads or duplicate stitch . . . The bands are ribbed. SIZE 8 is made with Crocus Crepe; Size 12 with Amore; Size 14 with Set 70.





SQUARES AND STRIPES

←

DK 8195 — Suited for Fall . . . or any season . . . Knit the Skirt and Sleeves in Stockinette stitch, the Jacket front and back using the Norwegian technique. Zip the front for easy closing. Sizes 16 and 18, both are made with Beatrice.

→

DK 8192 — Anywhere you go . . . anytime . . . you'll look smart and feel terrific in this lovely button down the front dress. The vertical stripes on front and back follow the Line drawing for the Norwegian Design. The sleeves and bands are in Stockinette stitch. Knit Size 12, 14 and 16 with Subita Crepe.



DK 8353 – DOUBLE UP! – It's twice the pleasure when you own a Twin Sweater Set . . . Wear them together or each on its own. The sleeveless Pullover has a Cable Design down the front section, the Cardigan has the Cable accent down the front sections. Size 10, 12 and 14 are made with Sport Prima.



HP 3710 — A Norwegian Design Pullover will brighten any man's life . . . Knit this one in 2 colors using your JAC 40 and Pattern #481 (a two card pattern) or you can follow the Line Drawing. The bands are ribbed. Use Sport Prima for Sizes 36, 38 and 40.





DK 8187 — Shades of Autumn are perfect for knitting a top of the line 3-piece Pantsuit. Knit the pants in Stockinette stitch, the sleeveless Pullover and front and back of Jacket in a Holding Position Design using 3 colors. For Size 12, use Subita Crepe; Size 14, Beatrice; Size 16, Regia.



DK 8343 — Fall into Winter . . . Weave a Jacket to wear over a softly shaped Stockinette stitch Dress. For Sizes 16 and 18, use Subita Crepe for the knitting, Melodie for weaving. For a Size 20, use Regia for knitting and Melodie for weaving.

New products from KNITKING

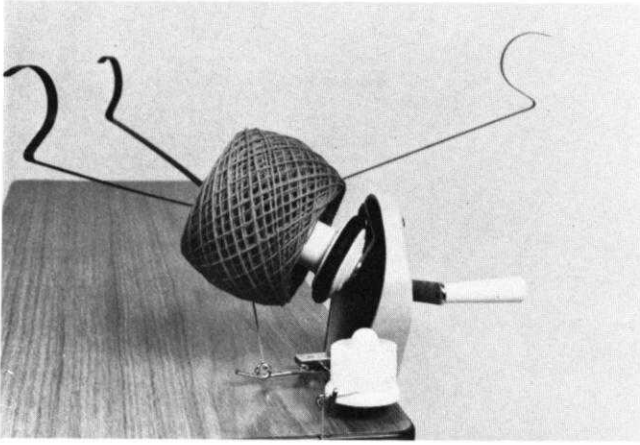

New design Yarn Winder with 'Waxamajig' and Skein Holder. As you can see from the illustration, this clever New Winder with Nylon Helical Gears winds a perfectly symmetrical ball. . . ! If you like to wax yarn (for easier knitting) you use the 'Waxamajig'. If waxing is not necessary, you bypass it . . . The Skein Holder is self adjusting. You will not find a better Hand Winder anywhere.

Complete price **\$23.95**
(California residents add Sales Tax)
 Shipping charges: \$1.75

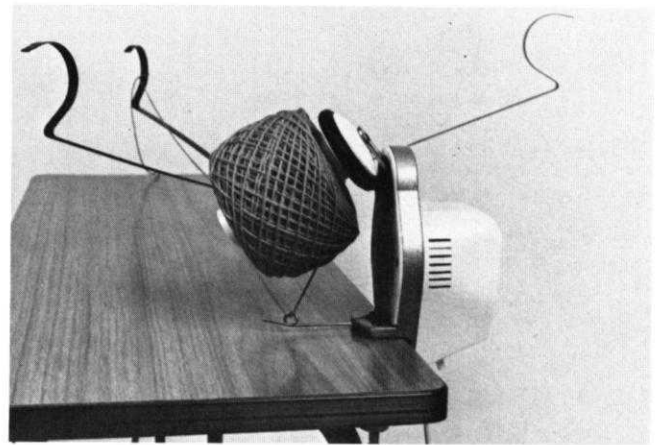

New design electric winder

Self-contained Motorized Winder (110/120 Volts) with Push Button on and off Switch . . . Special Clutch device to stop Winder if yarn bunches up or jams in the guide eye . . . Another excellent easy to use KNITKING product.

Price: Complete with Skein Holder **\$44.95**
(California residents add Sales Tax).
 Shipping Charges: \$2.50



knitking carrying bags

Completely new design in heavy duty canvas with waterproof interior. For AM 3 Knitter and Yarn Container.

List Price: **\$29.50**
 For Ribber only: **\$15.50**
(California residents add Sales Tax)
 Shipping Costs: \$1.75 and \$1.00

Order direct from KNITKING —
 1128 Crenshaw Blvd., Los Angeles, California 90019

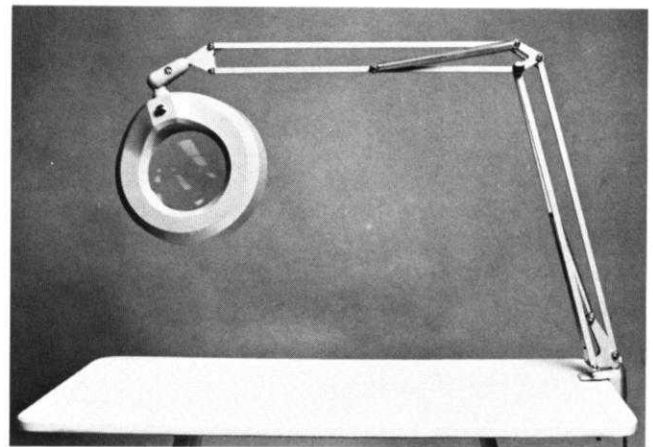

knitking magnifier lamp

A perfect gift item for any knitter. It has a large (5") magnifying lens and a cool fluorescent tube light. It stays in any position and is wonderful for general illumination for you to work under when joining seams, etc. Color: light grey.

List Price: **\$57.95**
(California residents add Sales Tax)
 Shipping Costs: \$3.00

DK 8267

SIZE:	14 (Bust 36"-37")	16 (Bust 38"-39")	18 (Bust 40"-41")
YARN:	C-1 Beatrice Silver C-2 Beatrice C-3 Beatrice	Beatrice Silver Beatrice Beatrice	Beatrice Silver Beatrice Beatrice
50 gr. BALLS:	13 C-1 1 C-2 1 C-3	13 C-1 1 C-2 1 C-3	14 C-1 2 C-2 1 C-3
TENSION:	3 to 5	4 to 6	5 to 7
GAUGE:	2" 17 sts. 23 rows	16 sts. 22 rows	15 sts. 21 rows

The instructions are the same for all sizes. PATTERN: Norwegian Design that follows the Line Drawing. In the instructions, each row of the Norwegian Design is counted as 1 row but several movements of the Cam Box are needed to complete 1 row. DECREASES: Hang the 2nd st. onto the 3rd st. and move the end st. in to fill the empty needle. INCREASES: Move the end st. 1 needle outward, then pick up the 2nd st. from the row below and hang it onto the empty needle. NECKBAND: Stockinette stitch.

FINISHING: Block all sections. Join side and shoulder seams. Sew sleeves together and set in. Hem lower edge of dress. Sew short ends of neckband together and sew 1 edge to inside and 1 to outside of neckline. Turn under and sew hem.

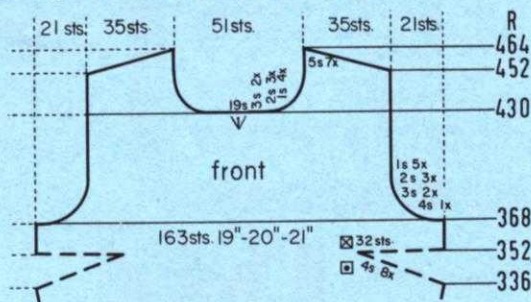

Move the Cam Box to the left side, turn the Row Counter back to 432, bring the needles into working position and complete the left half. Follow the instructions from*.

ON CAM BOX SIDE, shape shoulder by binding off 5 sts. after Rows 452, 454, 456, 458, 460, 462, 464.

*ON CAM BOX SIDE, bind off 3 sts. after Rows 431, 433 (ODD ROWS = NECK SHAPING); 2 sts. after Rows 435, 437, 439; 1 st. after Rows 441, 443, 445, 447. Knit to Row 452.

ON CAM BOX SIDE, bind off 4 sts. after Rows 368, 369; 3 sts. after Rows 370, 371, 372, 373; 2 sts. after Rows 374, 375, 376, 377, 378, 379; 1 st. after Rows 380, 381, 382, 383, 384, 385, 386, 387, 388, 389. Knit to Row 430, bind off the center 19 sts., put the needles on the left side into holding position and complete the right half first.

ON OPPOSITE SIDE OF CAM BOX, put into holding position 4 needles after Rows 336, 337, 338, 339, 340, 341, 342, 343, 344, 345, 346, 347, 348, 349, 350, 351. ON OPPOSITE SIDE OF CAM BOX, bring all the needles back into working position after Rows 352, 353. Knit even to Row 368.

Work the front section the same as the back section to Row 336, then work Short Rows.

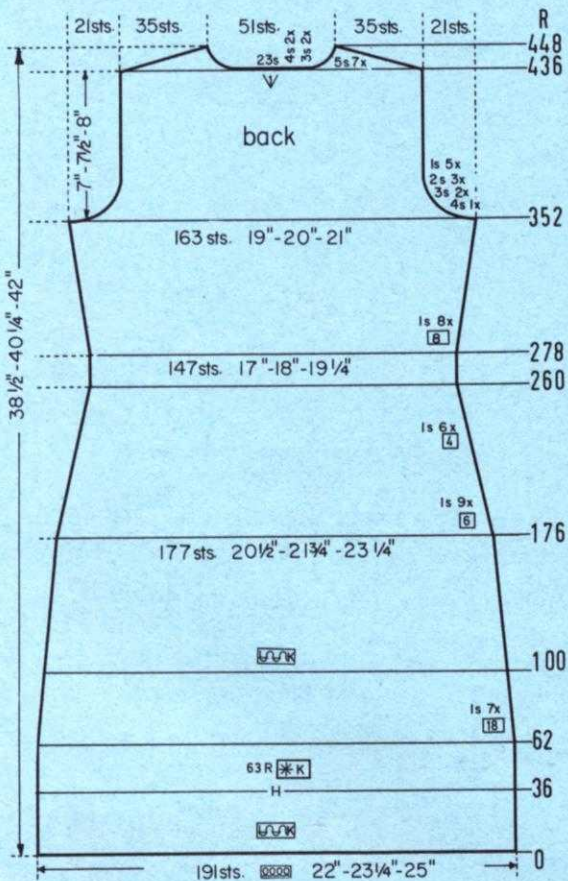

Move the Cam Box to the left, bring all the needles into working position, turn the Row Counter back to 436 and complete the left half. Follow the instructions from*.

*ON CAM BOX SIDE, bind off 5 sts. after Row 436 (EVEN ROWS = SHOULDER SHAPING); 4 sts. after Row 437 (ODD ROWS = NECK SHAPING); 5 sts. after Row 438; 4 sts. after Row 439; 5 sts. after Row 440; 3 sts. after Row 441; 5 sts. after Row 442; 3 sts. after Row 443; 5 sts. after Rows 444, 446, 448.

ON CAM BOX SIDE, bind off 4 sts. after Rows 352, 353; 3 sts. after Rows 354, 355, 356, 357; 2 sts. after Rows 358, 359, 360, 361, 362, 363; 1 st. after Rows 364, 365, 366, 367, 368, 369, 370, 371, 372, 373, then knit to Row 436. Bind off the center 23 sts. put the needles on the left side into holding position and complete the right half first.

ON EACH SIDE, increase 1 st. after Rows 278, 286, 294, 302, 310, 318, 326, 334. Knit to Row 352 (336 for front section).

ON EACH SIDE, decrease 1 st. after Rows 176, 182, 188, 194, 200, 206, 212, 218, 224, 230, 234, 238, 242, 246, 250. Knit to Row 278.

ON EACH SIDE, decrease 1 st. after Rows 62, 80, 98 (change to Stockinette stitch after Row 100) 116, 134, 152, 170. Knit to Row 176.

ROWS 0 to 36: Knit even then change to the Norwegian Design.

Cast on 191 sts. with color 1 and work Stockinette stitch.

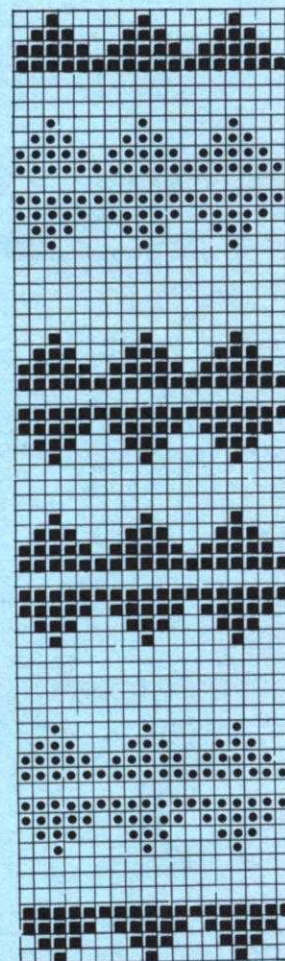

COLOR 3
 COLOR 1
 COLOR 2

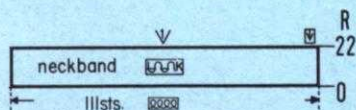

Cast on 111 sts. and work 22 rows Stockinette stitch, then bind off all sts.

Continued on page 10

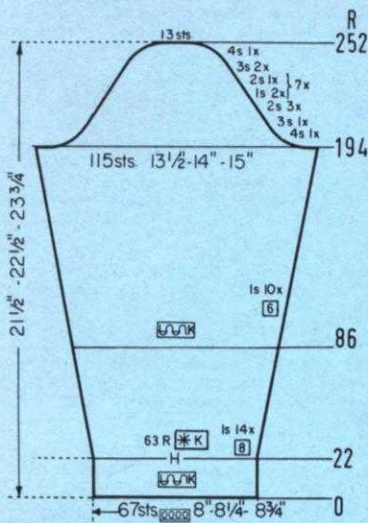

ON CAM BOX SIDE, bind off 4 sts. after Rows 194, 195; 3 sts. after Rows 196, 197; 2 sts. after Rows 198, 199, 200, 201, 202, 203; 1 st. after Rows 204, 205, 206, 207; 2 sts. after Rows 208, 209; 1 st. after Rows 210, 211, 212, 213; 2 sts. after Rows 214, 215; 1 st. after Rows 216, 217, 218, 219; 2 sts. after Rows 220, 221; 1 st. after Rows 222, 223, 224, 225; 2 sts. after Rows 226, 227; 1 st. after Rows 228, 229, 230, 231; 2 sts. after Rows 232, 233; 1 st. after Rows 234, 235, 236, 237; 2 sts. after Rows 238, 239; 1 st. after Rows 240, 241, 242, 243; 2 sts. after Rows 244, 245; 3 sts. after Rows 246, 247, 248, 249; 4 sts. after Rows 250, 251; 13 sts. after Row 252.

ON EACH SIDE, increase 1 st. after Rows 22, 30, 38, 46, 54, 62, 70, 78, (change to Stockinette stitch after Row 85) 86, 94, 102, 110, 118, 126, 134, 140, 146, 152, 158, 164, 170, 176, 182, 188. Knit to Row 194.

ROWS 0 to 22: Knit even, then change to the Norwegian Design.

Cast on 67 sts. with color 1 and work Stockinette stitch.

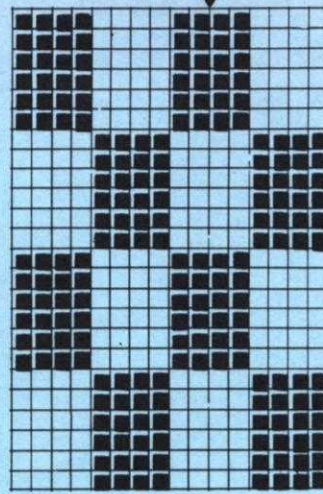

□ = COLOR 1 ■ = COLOR 2

DKS195

SIZE:	16 (Bust 37"-38")	18 (Bust 39"-40")
YARN:	Beatrice	Beatrice
50 gr. BALLS:	14 color 1 4 color 2	15 color 1 5 color 2
TENSION:	Stock Pattern 4 to 6 3 to 5	5 to 7 4 to 6
GAUGE:	2" Stk. 16 sts. 22 rows Pattern 17 sts. 25 rows	15 sts. 21 rows 16 sts. 24 rows

22" Jacket type Zipper



The instructions are the same for both sizes. PATTERN: JACKET Front and Back, Norwegian Design that follows the Chart. KNITTING machine owners use the Adjustable Needle Selector. Each Row in the Norwegian Design is counted as 1 row but several movements of the Cam Box are needed to complete 1 row. JACKET Sleeves and Bands: Stockinette stitch. SKIRT: Stockinette stitch. DECREASES in Pattern: Hang the 2nd st. onto the 3rd st. and move the end st. in to fill the empty needle. INCREASES: Move the end st. 1 needle outward then pick up the 2nd st. from the row below and place it onto the empty needle. INCREASES in Stockinette stitch: Move the 2 end sts. 1 needle outward, then pick up the 3rd st. from the row below and place it onto the empty needle. DECREASES: Hang the 3rd st. onto the 2nd st. then move the end sts. in to fill the empty needle.

FINISHING: Block all sections. JACKET: Join sides and shoulders easing in the fullness at bustline of front section. Sew sleeves together and set in. Make a 1/4" hem at lower edge. Fold bands in half lengthwise and sew 1 edge to inside and 1 to outside of front edges. Sew neckband to Jacket in same way. Sew in Zipper. SKIRT: Weave back and front sections together 1 st. in from each edge. Fold waistband in half and hem to the inside then insert elastic through hem. Turn under and hem 18 rows on lower edge.

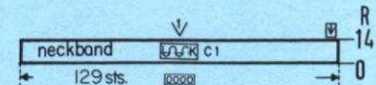
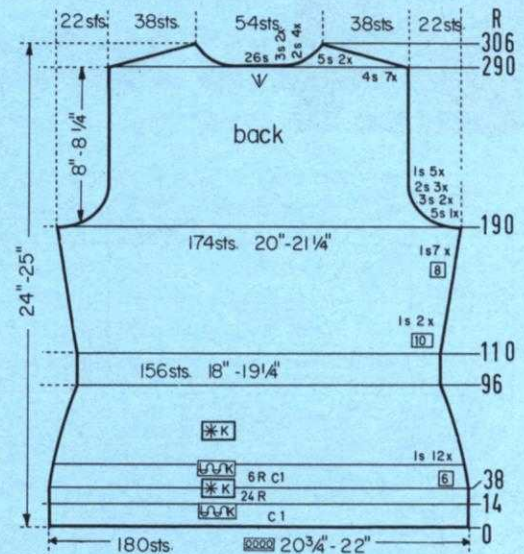

Cast on 129 sts. with color 1 and work 14 rows Stockinette stitch then bind off all sts.

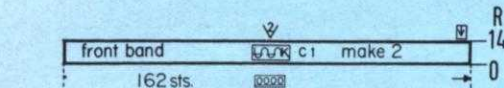

Cast on 162 sts. with color 1 and work 14 rows Stockinette stitch then bind off all sts. Make another band the same.

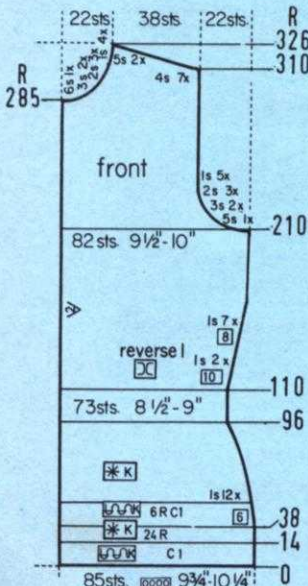

Work the second front section with reverse shaping, casting on from right to left. Cam Box will be on the left side at Row 0.

ON CAM BOX SIDE, bind off 4 sts. after Rows 310, 312, 314, 316, 318, 320, 322; 5 sts. after Rows 324, 326.

ON CAM BOX SIDE, bind off 6 sts. after Row 285; 3 sts. after Rows 287, 289; 2 sts. after Rows 291, 293, 295; 1 st. after Rows 297, 299, 301, 303. Knit to Row 310.

ON CAM BOX SIDE, bind off 5 sts. after Row 210; 3 sts. after Rows 212, 214; 2 sts. after Rows 216, 218, 220; 1 st. after Rows 222, 224, 226, 228, 230. Knit to Row 285.

ON CAM BOX SIDE, increase 1 st. after Rows 110, 120, 130, 138, 146, 154, 162, 170, 178. Knit to Row 210.

Cast on 85 sts. with color 1 and work 14 rows Stockinette stitch, 24 rows Pattern, 6 rows Stockinette stitch with color 1 and AT THE SAME TIME ON CAM BOX SIDE, decrease 1 st. after Rows 24, 30, 36, 42, (continue in Pattern after Row 44) 48, 54, 60, 66, 72, 78, 84, 90. Knit to Row 110.

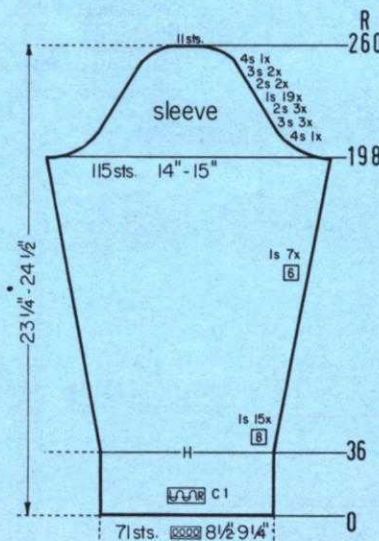

ON CAM BOX SIDE, bind off 4 sts. after Rows 198, 199; 3 sts. after Rows 200, 201, 202, 203, 204, 205; 2 sts. after Rows 206, 207, 208, 209, 210, 211. ON EACH SIDE, decrease 1 st. every 2nd row 19x. ON EACH SIDE, bind off 2 sts. after Rows 250, 251, 252, 253; 3 sts. after Rows 254, 255, 256, 257; 4 sts. after Rows 258, 259; 11 sts. after Row 260.

ON EACH SIDE, increase 1 st. after Rows 36, 44, 52, 60, 68, 76, 84, 92, 100, 108, 116, 124, 132, 140, 148, 156, 162, 168, 174, 180, 186, 192, then knit to Row 198.

ROWS 0 to 36: Knit even.

Cast on 71 sts. with color 1 and work Stockinette stitch.

DP 8175

SIZE:	8 (Bust 31"-32")	12 (Bust 33"-34")	14 (Bust 35"-36")
YARN:	Crocus Crepe	Amore	Set 70 Crepe
50 gr. BALLS:	7 color 1 2 color 2	6 color 1 1 color 2	9 color 1 2 color 2
TENSION:	5 to 7	7 to 9	7 to 9
GAUGE:	2" 16 sts. 23 rows	15 sts. 23 rows	14 sts. 21 rows



The instructions are the same for all sizes. PATTERN: Stockinette stitch with repeated color stripes as marked in the Diagram. EDGES: K1, P1 Ribbing. INCREASES: Move the 2 end sts. 1 needle outward, then place the 3rd st. from the row below onto the empty needle.

FINISHING: Block the sections. Join front and back section at sides and shoulders. Join the short ends of the armhole bands and the short ends of the neckband, then sew the bands in place.

Bring the needles on the left into working position, knit 1 row in Pattern to the left side, turn the Row Counter back to 290 and complete the left half. Follow the instructions from*.

*ON CAM BOX SIDE, bind off 4 sts. after Row 290 (EVEN ROWS = SHOULDER SHAPING); 3 sts. after Row 291 (ODD ROWS = NECK SHAPING); 4 sts. after Row 292; 3 sts. after Row 293; 4 sts. after Row 294; 2 sts. after Row 295; 4 sts. after Row 296; 2 sts. after Row 297; 4 sts. after Row 298; 2 sts. after Row 299; 4 sts. after Row 300; 2 sts. after Row 301; 4 sts. after Row 302; 5 sts. after Rows 304, 306.

ON CAM BOX SIDE, bind off 5 sts. after Rows 190, 191; 3 sts. after Rows 192, 193, 194, 195; 2 sts. after Rows 196, 197, 198, 199, 200, 201; 1 st. after Rows 202, 203, 204, 205, 206, 207, 208, 209, 210, 211. Knit to Row 290, bind off the center 26 sts., put the needles on the left side into holding position and complete the right half first.

ON EACH SIDE, increase 1 st. after Rows 110, 120, 130, 138, 146, 154, 162, 170, 178, then knit to Row 190 (210 for Front section).

Cast on 180 sts. with color 1 and work 14 rows Stockinette stitch, 24 rows Pattern, 6 rows Stockinette stitch with color 1 and AT THE SAME TIME ON EACH SIDE, decrease 1 st. after Rows 24, 30, 36, 42, (continue in Pattern after Row 44) 48, 54, 60, 66, 72, 78, 84, 90. Knit to Row 110.

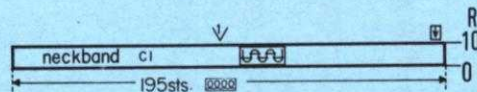
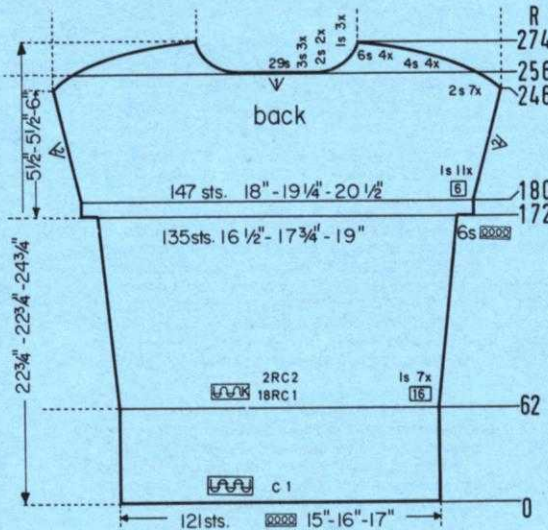

Cast on 195 sts. with color 1 and work 10 rows K1, P1 Ribbing, then bind off all sts.

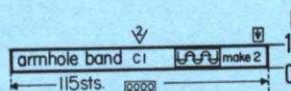
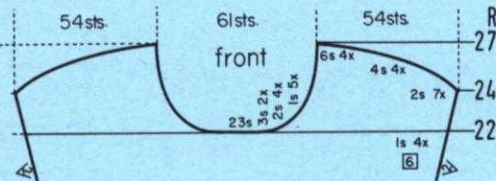

Decrease 2 sts. for EACH DART after Rows in (), the first time hang the 54th and 56th sts. ON EACH SIDE onto the 55th needle and move the sts. in to fill the empty needles. The following DART decreases lie directly above. ON EACH SIDE, decrease 1 st. after Rows 220 (220), (228), 230, (236), 240, (244), 250, (252), 260 (260), (268), 270, (276), 280. Knit to Row 304 and bind off the remaining sts.

ON EACH SIDE, decrease 1 st. after Rows 62, 74, 86, 98, 110, 122, 134, 146, 158, 170, 182, 194. Knit to Row 220.

ROWS 0 to 62: Knit even.

Cast on 197 sts. with color 1 and work Stockinette stitch.

Move the Cam Box to the left side, turn the Row Counter back to 256 and complete the left half. Follow the instructions from*.

*ON CAM BOX SIDE, bind off 2 sts. after Row 256 (EVEN ROWS = SHOULDER SHAPING); 3 sts. after Row 257 (ODD ROWS = NECK SHAPING); 2 sts. after Row 258; 3 sts. after Row 259; 4 sts. after Row 260; 3 sts. after Row 261; 4 sts. after Row 262; 2 sts. after Row 263; 4 sts. after Row 264; 2 sts. after Row 265; 4 sts. after Row 266; 1 st. after Row 267; 6 sts. after Row 268; 1 st. after Row 269; 6 sts. after Row 270; 1 st. after Row 271; 6 sts. after Rows 272, 274.

ON CAM BOX SIDE, bind off 2 sts. after Rows 246, 247, 248, 249, 250, 251, 252, 253, 254, 255, then knit to Row 256, bind off the center 29 sts., put the needles on the left side into holding position and complete the right half first.

ON EACH SIDE, increase 1 st. after Rows 180, 186, 192, 198, 204, 210, 216, 222, 228, 234, 240, then knit to Row 246. (For the Front Section knit to Row 222, but do not make the increases after Row 222).

ON EACH SIDE, increase 1 st. after Rows 62, 78, 94, 110, 126, 142, 158, then knit to Row 172. Cast on 6 sts. ON EACH SIDE, (use a separate length of yarn for the left side) then knit to Row 180.

ROWS 0 to 62: Knit even, then change to Stockinette stitch and work the repeated color stripes as marked in the Diagram.

Cast on 121 sts. with color 1 and work K1, P1 Ribbing.

Move the Cam Box to the left side, turn the Row Counter back to 222 and complete the left half. Follow the instructions from*.

*Continue to increase 1 st. ON CAM BOX SIDE after Row 222, then again after Rows in (). ON NECK SIDE, bind off 3 sts. after Rows 223, 225; 2 sts. after Rows 227, (228), 229, 231, 233; (234); 1 st. after Rows 235, 237, 239, (240), 241, 243. For SHOULDER bind off 2 sts. after Rows 246, 248, 250, 252, 254, 256, 258; 4 sts. after Rows 260, 262, 264, 266; 6 sts. after Rows 268, 270, 272, 274.

Work the front section the same as the back section to ROW 222, then bind off the center 23 sts., put the needles on the left side into holding position and complete the right half first.

Cast on 115 sts. with color 1 and work 10 rows K1, P1 Ribbing, then bind off all sts.

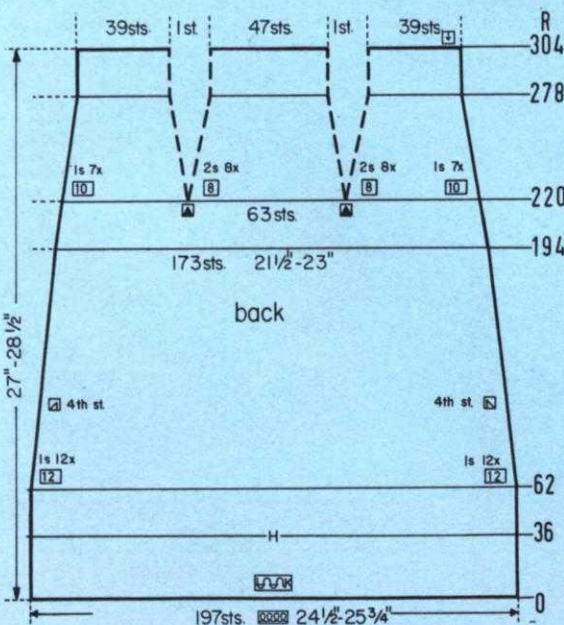

Continued on page 12

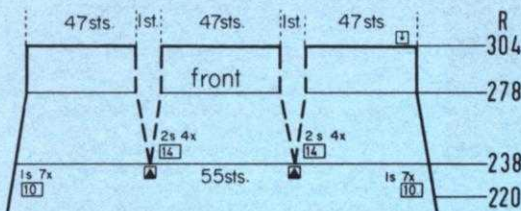

Decrease 2 sts. for EACH DART after Rows in (), the first time hang the 57th and 59th sts. ON EACH SIDE onto the 58th needle and move the sts. in to fill the empty needles. The following DART decreases lie directly above. ON EACH SIDE, decrease 1 st. after Rows 220, 230, (238), 240, 250, (252), 260, (266), 270, 280 (280). Knit to Row 304 and bind off the remaining sts.

Work the Front section the same as the Back section to Row 220.

DK8192

SIZE:	12 (Bust 33"-34")	14 (Bust 36"-37")	16 (Bust 38"-39")
YARN:	Subita Crepe	Subita Crepe	Subita Crepe
50 gr. BALLS:	10 color 1 8 color 2	11 color 1 9 color 2	12 color 1 10 color 2
TENSION:	Stock 2 to 4 Pattern 3 to 5	3 to 5 4 to 6	4 to 6 5 to 7
GAUGE:	2" Stk. 18 sts. 24 rows Pattern 18 sts. 22 rows	17 sts. 24 rows 17 sts. 22 rows	16 sts. 23 rows 16 sts. 21 rows

The instructions are the same for all sizes. PATTERN: Norwegian Design that follows the Line Drawing. KNITTING machine owners use the Adjustable Needle Selector. In the instructions, each row of the Norwegian Design is counted as 1 row but several movements of the Cam Box are needed to complete 1 row. SLEEVES, COLLAR and BANDS: Stockinette stitch. DECREASES: (For Norwegian Design) Hang the 2nd st. onto the 3rd st. and move the end st. in to fill the empty needle. INCREASES: Move the end st. 1 needle outward then pick up the 2nd st. from the row below and hang it onto the empty needle. DECREASES: (Stockinette stitch) Place the 3rd st. onto the 2nd st. and move the end sts. in to fill the empty needle. INCREASES: Move the 2 end sts. 1 needle outward then place the 3rd st. from the row below onto the empty needle.

FINISHING: Block all sections. Join front and back sections at sides and shoulders easing in the fullness at bustline of front section. Sew sleeves together and set in. Gather lower edge of Sleeves to wrist measurement. Fold Cuffs in half lengthwise and sew to sleeve edge with 1 edge to inside and to outside of sleeve. Make a 1/4" hem on lower edge. Sew buttonhole and button bands to dress. Fold Collar in half lengthwise and close short ends, then sew 1 edge of Collar to the inside and 1 to the outside of neck edge leaving 3/4" on each side free.

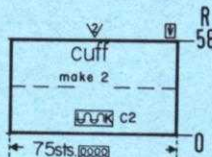
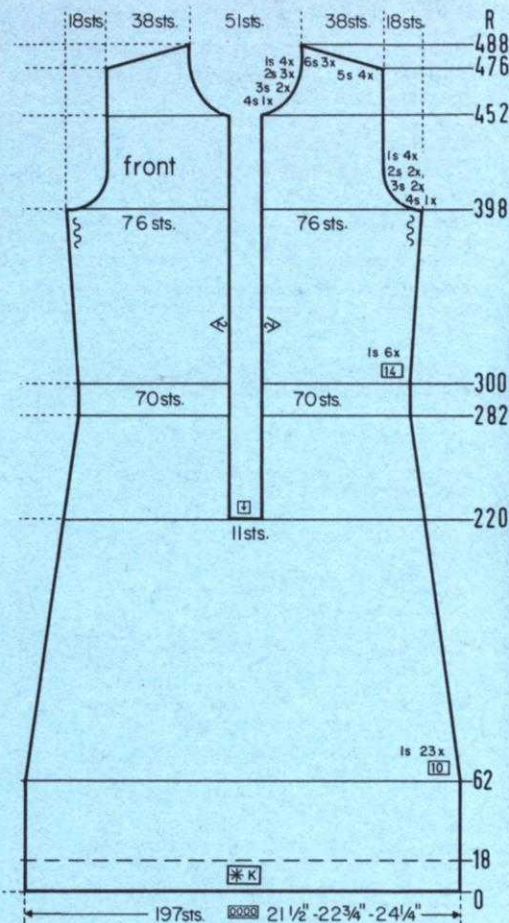
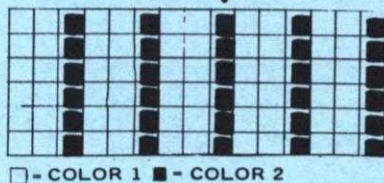

Cast on 75 sts. with color 2 and work 58 rows Stockinette stitch, then bind off all sts.

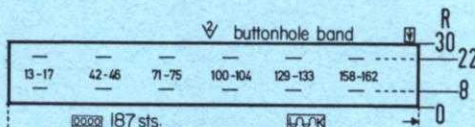

Cast on 187 sts. with color 2 and work Stockinette stitch. Make BUTTONHOLES after Rows 8 and 22 over needles 13 to 17; 42 to 46; 71 to 75; 100 to 104; 129 to 133, counting from the left edge. After Row 30, bind off all sts. Make a second band the same but omit the buttonholes.

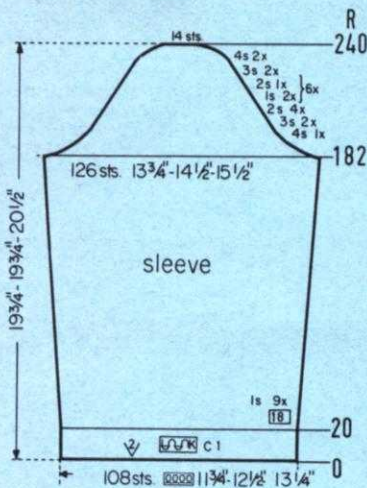

ON CAM BOX SIDE, bind off 4 sts. after Rows 182, 183; 3 sts. after Rows 184, 185, 186, 187; 2 sts. after Rows 188, 189, 190, 191, 192, 193, 194, 195; 1 st. after Rows 196, 197, 198, 199; 2 sts. after Rows 200, 201; 1 st. after Rows 202, 203, 204, 205; 2 sts. after Rows 206, 207; 1 st. after Rows 208, 209, 210, 211; 2 sts. after Rows 212, 213; 1 st. after Rows 214, 215, 216, 217; 2 sts. after Rows 218, 219; 1 st. after Rows 220, 221, 222, 223; 2 sts. after Rows 224, 225; 1 st. after Rows 226, 227, 228, 229; 2 sts. after Rows 230, 231; 3 sts. after Rows 232, 233, 234, 235; 4 sts. after Rows 236, 237, 238, 239; 14 sts. after Row 240.

ON EACH SIDE, increase 1 st. after Rows 20, 38, 56, 74, 92, 110, 128, 146, 164. Knit to Row 182.

ROWS 0 to 20: Knit even.

Cast on 108 sts. with color 1 and work Stockinette stitch.

ON EACH SIDE, decrease 1 st. after Rows 48, 52, 56, 60, 64, 68, 72, 76, 80. Knit to Row 86 and bind off all sts.

ON EACH SIDE, increase 1 st. after Rows 10, 14, 18, 22, 26, 30, 34, 38, 42, then knit to Row 48.

ON OPPOSITE SIDE OF CAM BOX, put into holding position 44 needles at Row 0 and after Row 1. ON OPPOSITE SIDE OF CAM BOX, bring back into working position 11 needles after Rows 2, 3, 4, 5, 6, 7, 8, 9.

Cast on 144 sts. with color 2 and work Stockinette stitch and Short Rows.

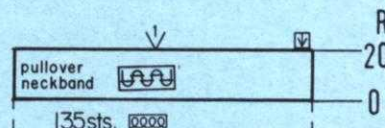
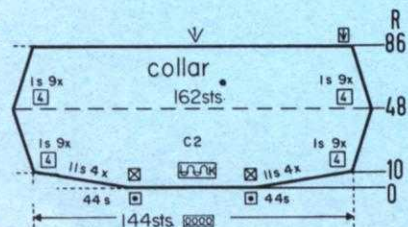

Cast on 135 sts. and work 20 rows K1, P1 Ribbing, then bind off all sts. the crochet method for Ribbing.

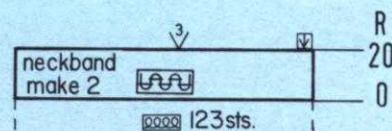

Bring the needles on the left into working position, knit 1 row in Pattern to the left side, turn the Row Counter back to 220 and complete the left half. Follow the instructions from*.

ON CAM BOX SIDE, bind off 4 sts. after Row 453 (ODD ROWS = NECK SHAPING); 3 sts. after Rows 455, 457; 2 sts. after Rows 459, 461, 463; 1 st. after Rows 465, 467, 469, 471. Knit to Row 478 and SHAPE SHOULDER ON CAM BOX SIDE by binding off 5 sts. after Rows 478, 480, 482, 484; 6 sts. after Rows 486, 488, 490.

ON CAM BOX SIDE, bind off 4 sts. after Row 398; 3 sts. after Rows 400, 402; 2 sts. after Rows 404, 406; 1 st. after Rows 408, 410, 412, 414. Knit to Row 452.

ON CAM BOX SIDE, increase 1 st. after Rows 300, 314, 328, 342, 356, 370, then knit to Row 398.

*ON CAM BOX SIDE, decrease 1 st. after Rows 222, 232, 242, 252, 262, 272, then knit to Row 300.

ON EACH SIDE, decrease 1 st. after Rows 62, 72, 82, 92, 102, 112, 122, 132, 142, 152, 162, 172, 182, 192, 202, 212. Knit to Row 220, bind off the center 11 sts. and complete the right half first.

ROWS 0 to 62: Knit even.

Cast on 197 sts. with color 1 and work the Norwegian Design.

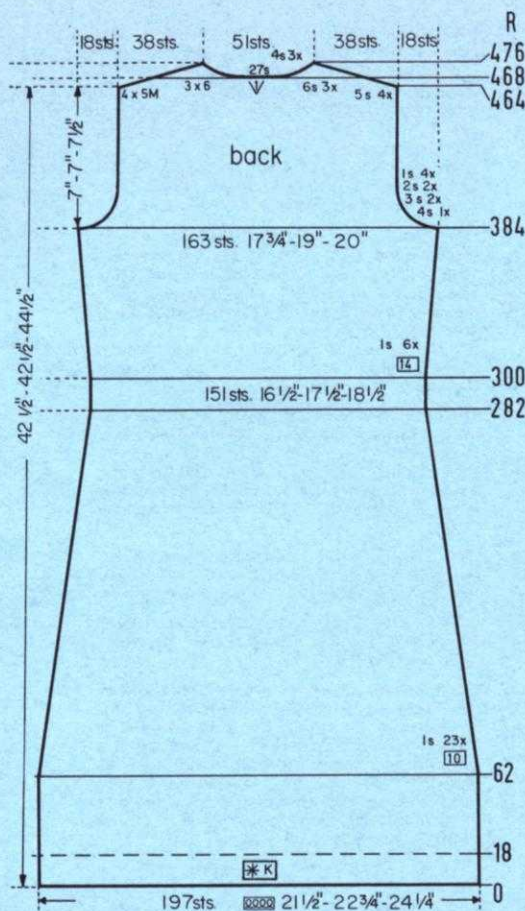

Bring the needles on the left side into working position, knit 1 row in Pattern to the left, turn the Row Counter back to 468 and complete the left half. Follow the instructions from*.

*ON CAM BOX SIDE, bind off 5 sts. after Row 468 (EVEN ROWS = SHOULDER SHAPING); 4 sts. after Row 469 (ODD ROWS = NECK SHAPING); 5 sts. after Row 470; 4 sts. after Row 471; 6 sts. after Row 472; 4 sts. after Row 473; 6 sts. after Rows 474, 476.

ON CAM BOX SIDE, bind off 5 sts. after Rows 464, 465, 467. After Row 468, bind off the center 27 sts., put the needles on the left side into holding position and complete the right half first.

ON CAM BOX SIDE, bind off 4 sts. after Rows 384, 385; 3 sts. after Rows 386, 387, 388, 389; 2 sts. after Rows 390, 391, 392, 393; 1 st. after Rows 394, 395, 396, 397, 398, 399, 400, 401. Knit to Row 464.

ON EACH SIDE, increase 1 st. after Rows 300, 314, 328, 342, 356, 370. Knit to Row 384.

ON EACH SIDE, decrease 1 st. after Rows 62, 72, 82, 92, 102, 112, 122, 132, 142, 152, 162, 172, 182, 192, 202, 212, 222, 232, 242, 252, 262, 272, 282, then knit to Row 300.

ROWS 0 to 62: Knit even.

Cast on 197 sts. with color 1 and work the Norwegian Design.

DK 8353

SIZE:	10 (Bust 32"-33")	12 (Bust 34"-35")	14 (Bust 36"-37")
YARN:	Sport Prima	Sport Prima	Sport Prima
50 gr. BALLS:	18	20	22
TENSION:	6 to 8	7 to 9	8 to 10
GAUGE:	2" 14 sts. 19 rows	13 sts. 18 rows	12 sts. 17 rows

The instructions are the same for all sizes. PATTERN: Stockinette stitch with Cable Stitch panel on the front of Pullover and Cardigan according to the Line Drawing. EDGES: K1, P1 Ribbing or you may use a Mock Rib by doubling the amount of rows and make a hem. Remember to turn the Row Counter back (also you should purchase 2 extra balls of yarn for doubled edges). (See Practical Knitting Hints May/June 1974, Volume 10 No. 5 for Mock Ribbing instructions). DECREASES: Hang the 3rd st. onto the 2nd st. then move the end sts. in to fill the empty needle. INCREASES: Move the 2 end sts. 1 needle outward, then place the 3rd st. from the row below onto the empty needle.

FINISHING: Block all sections. PULLOVER: Join front and back sections at sides and shoulders. Join the short ends of neckband, then sew 1 edge to the inside and 1 to the outside of neckline. Sew the armhole bands to the armhole edges in the same manner. CARDIGAN: Join the fronts and back sections at sides and shoulder. Sew the sleeves together and set in. Sew pockets in place. Sew front bands to front of Cardigan then sew neckband in place.



Cast on 123 sts. and work 20 rows K1, P1 Ribbing then bind off all sts. the crochet method for Ribbing.

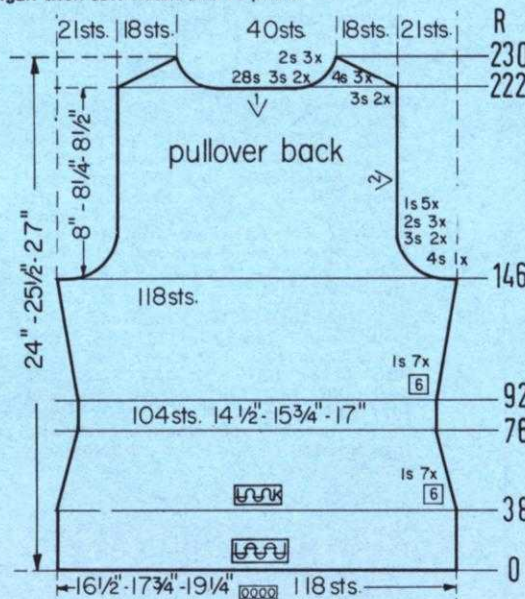
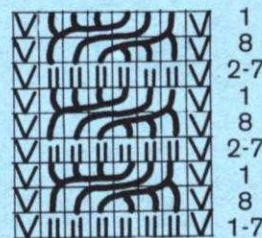

Move the Cam Box to the left side, turn the Row Counter back to 222 and complete the left half. Follow the instructions from*.

*ON CAM BOX SIDE, bind off 3 sts. after Row 222 (EVEN ROWS = SHOULDER SHAPING); 3 sts. after Row 223 (ODD ROWS = NECK SHAPING); 3 sts. after Rows 224, 225; 4 sts. after Row 226; 2 sts. after Row 227; 4 sts. after Row 228; 2 sts. after Row 229; 4 sts. after Row 230; 2 sts. after Row 231.

ON CAM BOX SIDE, bind off 4 sts. after Rows 146, 147; 3 sts. after Rows 148, 149, 150, 151; 2 sts. after Rows 152, 153, 154, 155, 156, 157, then knit to Row 222, bind off the center 28 sts., put the needles on the left side into holding position and complete the right half first.

ON EACH SIDE, increase 1 st. after Rows 92, 98, 104, 110, 116, 122, 128, then knit to Row 146.

ON EACH SIDE, decrease 1 st. after Rows 40, 46, 52, 58, 64, 70, 76, then knit to Row 92.

ROWS 0 to 38: Knit even then transfer the Ribber sts. to main machine and continue in Stockinette stitch.

Cast on 118 sts. and work K1, P1 Ribbing.

Continued on page 14

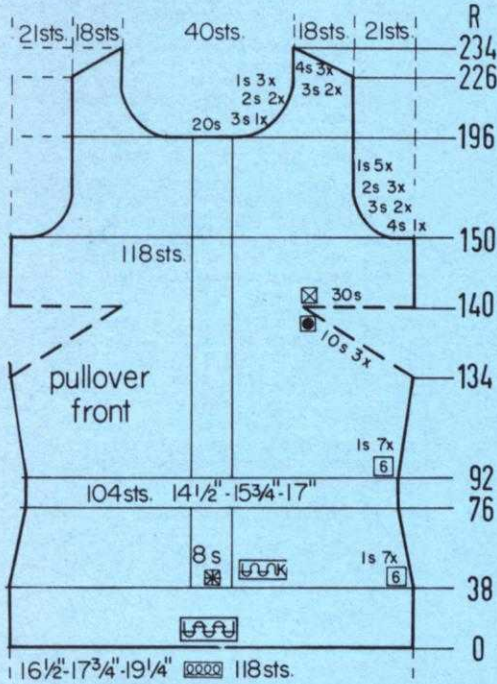

Move the Cam Box to the left side, turn the Row Counter back to 196 and complete the left half. Follow the instructions from*.

*ON CAM BOX SIDE, bind off 3 sts. after Row 197; 2 sts. after Rows 199, 201; 1 st. after Rows 203, 205, 207, then knit to Row 226. ON CAM BOX SIDE, bind off 3 sts. after Rows 226, 228; 4 sts. after Rows 230, 232, 234.

ON CAM BOX SIDE, bind off 4 sts. after Rows 150, 151; 3 sts. after Rows 152, 153; 2 sts. after Rows 154, 155, 156, 157, 158, 159. ON EACH SIDE, decrease 1 st. after Rows 160, 162, 164, 166, 168, then knit to Row 196, bind off the center 20 sts., put the needles on the left side into holding position and complete the right half first.

ON OPPOSITE SIDE OF CAM BOX, put into holding position 10 needles after Rows 134, 135, 136, 137, 138, 139. ON OPPOSITE SIDE OF CAM BOX, bring back into working position all needles after Rows 140, 141, then knit to Row 150.

ON EACH SIDE, increase 1 st. after Rows 92, 98, 104, 110, 116, 122, 128. Knit to Row 134 then work Short Rows.

ON EACH SIDE, decrease 1 st. after Rows 40, 46, 52, 58, 64, 70, 76, then knit to Row 92.

ROWS 0 to 38: Knit even, then transfer the Ribber sts. to the main machine and continue in Stockinette stitch with Cable Pattern on the center 8 sts. Set up the Pattern as in the Line Drawing (the 1st and 8th stitches are transferred to the next needle and the empty needles left in the out of work position but count them as stitches throughout).

Cast on 118 sts. and work K1, P1 Ribbing.

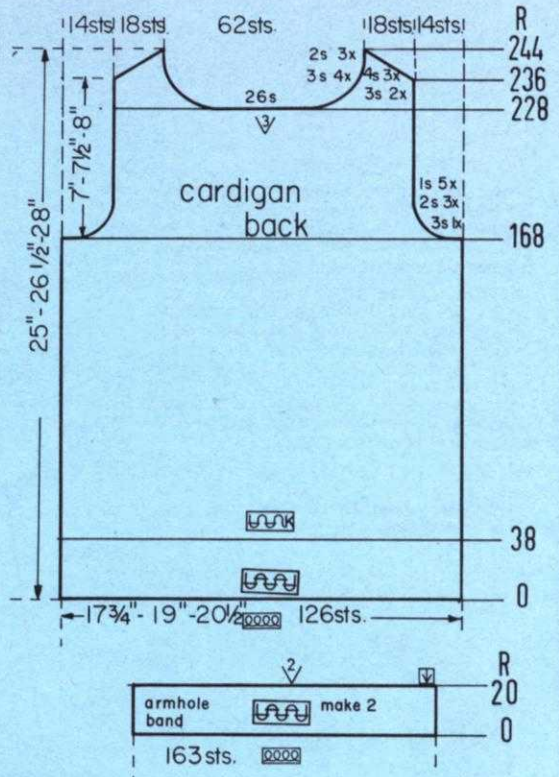

HP 3710

SIZE:	36 (Chest 36"-37")	38 (Chest 38"-39")	40 (Chest 40"-41")
YARN:	Sport Prima	Sport Prima	Sport Prima
50 gr. BALLS:	8 C-1 5 C-2	8 C-1 5 C-2	9 C-1 6 C-2
TENSION:	6 to 8	7 to 9	8 to 10
GAUGE:	2" 15 sts. 20 rows	14 sts. 19 rows	13 sts. 18 rows

The instructions are the same for all sizes. PATTERN: Norwegian Design that follows the Line Drawing or Use JAC 40 and Pattern No. 481. In the instructions, each row of the Norwegian Design is counted as 1 row but several movements of the Cam Box are needed to complete 1 row. DECREASES: Hang the 2nd st. onto the 3rd st. and move the end st. in to fill the empty needle. INCREASES: Move the end st. 1 needle outward, then pick up the 2nd st. from the row below and hang it onto the empty needle.

FINISHING: Block all sections. Weave side seams together 1 st. in from each edge. Weave sleeve seams and set in sleeves. Sew shoulder seams. Sew short sides of Collar together, then sew Collar to neckline and fold in half to the outside.

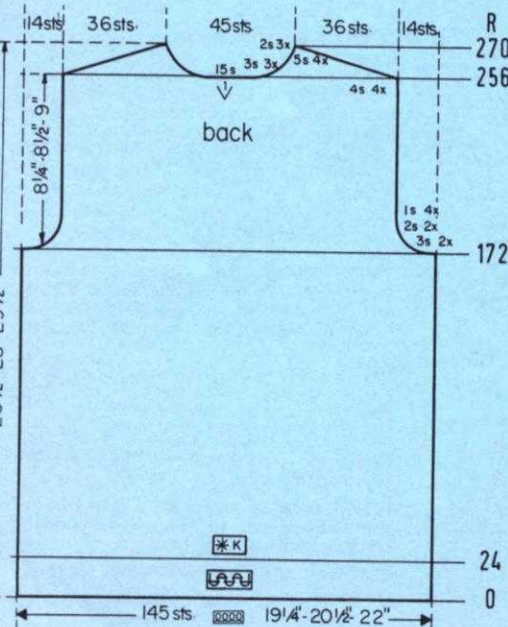

Bring the needles on the left side into working position, knit 1 row in pattern to the left side, turn the Row Counter back to 256 and complete the left half. Follow the instructions from*.

*ON CAM BOX SIDE, bind off 4 sts. after Row 172 (EVEN ROWS = SHOULDER SHAPING); 3 sts. after Row 257 (ODD ROWS = NECK SHAPING); 4 sts. after Row 258; 3 sts. after Row 259; 4 sts. after Row 260; 3 sts. after Row 261; 4 sts. after Row 262; 2 sts. after Row 263; 5 sts. after Row 264; 2 sts. after Row 265; 5 sts. after Row 266; 2 sts. after Row 267; 5 sts. after Rows 268, 270.

ON CAM BOX SIDE, bind off 3 sts. after Rows 172, 173, 174, 175; 2 sts. after Rows 176, 177, 178, 179; 1 st. after Rows 180, 181, 182, 183, 184, 185, 186, 187. Knit to Row 256 (236 for Front section). Bind off the center 15 sts., put the needles on the left side into holding position and complete the right half first.

ROWS 25 to 172: Knit even.

ROWS 0 to 24: Knit even, then change to the Norwegian Design.

Cast on 145 sts. with color 1 and work K1, P1 Ribbing.

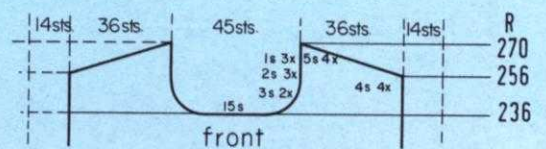
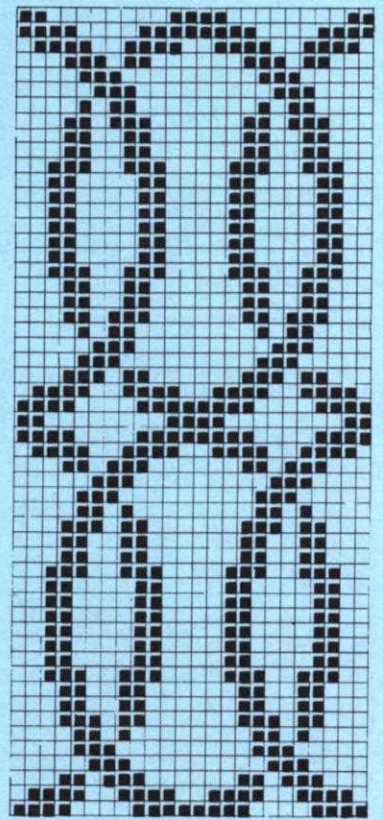

Move the Cam Box to the left side, turn the Row Counter back to 228 and complete the left half. Follow the instructions from*.

*ON CAM BOX SIDE, bind off 3 sts. after Rows 229, 231, 233, 235 (ODD ROWS = NECK SHAPING); 3 sts. after Row 236 (EVEN ROWS = SHOULDER SHAPING); 2 sts. after Row 237; 3 sts. after Row 238; 2 sts. after Row 239; 4 sts. after Row 240; 2 sts. after Row 241; 4 sts. after Rows 242, 244.

ON CAM BOX SIDE, bind off 3 sts. after Rows 168, 169; 2 sts. after Rows 170, 171, 172, 173, 174, 175. ON EACH SIDE, decrease 1 st. after Rows 176, 178, 180, 182, 184, then knit to Row 228, bind off the center 26 sts., put the needles on the left side into holding position and complete the right half first.

ROWS 39 to 168: Knit even.

ROWS 0 to 38: Knit even, then change to Stockinette stitch.

Cast on 126 sts. and work K1, P1 Ribbing.

Cast on 163 sts. and work 20 rows K1, P1 Ribbing, then bind off all sts. the crochet method for Ribbing.

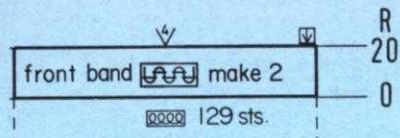
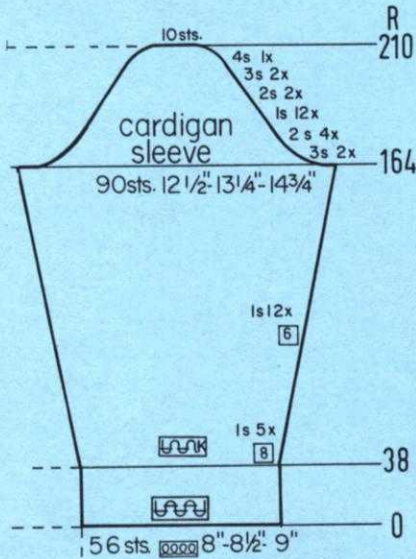

Cast on 129 sts. and work 20 rows K1, P1 Ribbing then bind off all sts. the crochet method for Ribbing.

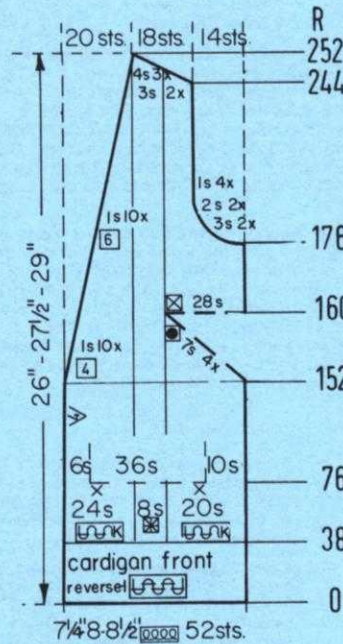

ON CAM BOX SIDE, bind off 2 sts. after Rows 200, 201, 202, 203; 3 sts. after Rows 204, 205, 206, 207; 4 sts. after Rows 208, 209; 10 sts. after Row 210.

ON CAM BOX SIDE, bind off 3 sts. after Rows 164, 165, 166, 167; 2 sts. after Rows 168, 169, 170, 171, 172, 173, 174, 175. ON EACH SIDE decrease 1 st. after Row 176, then every 2nd row 11x more.

ON EACH SIDE, increase 1 st. after Rows 40, 48, 56, 64, 70, 78, 84, 90, 96, 102, 108, 114, 120, 126, 132, 138, 144, then knit to Row 164.

ROWS 0 to 38: Knit even, then change to Stockinette stitch. Cast on 56 sts. and work K1, P1 Ribbing.

Make the second Front section with reverse shaping, casting on from Right to Left. Cam Box will be on the LEFT side at Row 0.

ON CAM BOX SIDE, bind off 3 sts. after Rows 244, 246 (247 last neck decrease); 4 sts. after Rows 248, 250, 252.

ON NECK SIDE, decrease 1 st. after Rows in (). ON OPPOSITE SIDE OF CAM BOX put 7 needles into holding position after Rows 153 (153), 155, 157 (157), 159. After Row 161 (161) bring all the needles back into working position and continue to decrease 1 st. on neck side after Rows (165, 169, 173). ON CAM BOX SIDE, bind off 3 sts. after Rows 176, (177), 178; 2 sts. after Rows 180, (181), 182; 1 st. after Rows 184, (185), 186, 188, (189), 190. Continue to decrease 1 st. on neck side after Rows (193, 199, 205, 211, 217, 223, 229, 235, 241).

ON OPPOSITE SIDE OF CAM BOX, put 6 sts. into holding position after Row 76 and 10 sts. after Row 77. On remaining 36 sts. work K1, P1 Pocket Band for 10 rows, then bind off. ON SAME 36 needles, cast on, on the main machine for pocket. Knit 48 rows. Turn the Row Counter to 76. ON OPPOSITE SIDE OF CAM BOX, bring 6 needles into working position after Row 76 and 10 needles after Row 77, then knit to Row 152. Begin the Front neckline shaping and make Bust Dart.

ROWS 39 to 76: Knit even.

ROWS 0 to 38: Knit even then change to Stockinette stitch with Cable Pattern over the 8 sts. as marked on the Chart (20 sts. in from side edge - 24 sts. in from front edge).

Cast on 52 sts. and work K1, P1 Ribbing.

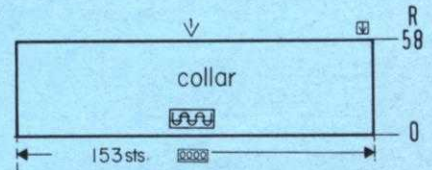

Cast on 153 sts. with color 1 and work 58 Rows K1, P1 Ribbing then bind off all sts. the crochet method for ribbing.

Bring the needles on the left into working position, knit 1 row in Pattern to the left side, turn the Row Counter back to 236 and complete the left half. Follow the instructions from*.

ON CAM BOX SIDE, shape shoulder by binding off 4 sts. after Rows 256, 258, 260, 262; 5 sts. after Rows 264, 266, 268, 270.

*ON CAM BOX SIDE, bind off 3 sts. after Rows 237, 239 (ODD ROWS = NECK SHAPING); 2 sts. after Rows 241, 243, 245; 1 st. after Rows 247, 249, 251. Knit to Row 256.

Work the Front section the same as the Back section to Row 236, bind off the center 15 sts., put the needles on the left into holding position and complete the right half first.

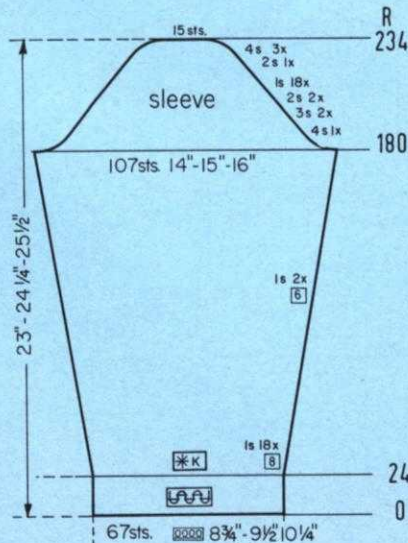

ON CAM BOX SIDE, bind off 4 sts. after Rows 180, 181; 3 sts. after Rows 182, 183, 184, 185; 2 sts. after Rows 184, 187, 188, 189. ON EACH SIDE, decrease 1 st. every other row 18x. ON CAM BOX SIDE, bind off 2 sts. after Rows 226, 227; 4 sts. after Rows 228, 229, 230, 231, 232, 233; 15 sts. after Row 234.

ON EACH SIDE, increase 1 st. after Rows 24, 32, 40, 48, 56, 64, 72, 80, 88, 96, 104, 112, 120, 128, 136, 144, 152, 160, 168, 174. Knit to Row 180.

ROWS 0 to 24: Knit even, then change to the Norwegian Design.

Cast on 67 sts. with color 1 and work K1, P1 Ribbing.

DKS187

SIZE:	12 (Bust 33"-34")	14 (Bust 35"-36")	16 (Bust 37"-38")
YARN:	Subita Crepe	Beatrice	Regia
50 gr. BALLS:			
Pants	10 color 1	11 color 1	12 color 1
Jacket & Pull.	6 color 1 8 color 2 4 color 3	7 color 1 9 color 2 5 color 3	8 color 1 9 color 2 6 color 3
TENSION:			
Stock	3 to 5	3 to 5	4 to 6
Pattern	2 to 4	2 to 4	3 to 5
GAUGE:			
2" Stk.	18 sts. 24 rows	17 sts. 23 rows	16 sts. 23 rows
Pattern	18 sts. 38 rows	17 sts. 36 rows	17 sts. 36 rows

The instructions are the same for all sizes. PANTS: Stockinette stitch. PULLOVER and JACKET: Holding Position Design that follows the Line Drawing. KNITTING Machine owners, use WHEEL No. W3 for Pattern and remember when shaping the left half of necklines in Pattern, that you must always work the Pattern from the Right side of machine even though there will be an ODD number on the Row Counter. BANDS: K1, P1 Ribbing. DECREASES Pants: Place the 3rd st. onto the 2nd st. and move the end sts. in to fill the empty needle. INCREASES Pants: Move the 2 end sts. 1 needle outward then place the 3rd st. from the row below onto the empty needle. Make all increases and decreases on the edges for the Pullover and Jacket backs and fronts.

FINISHING: Block all sections. Pants: Weave the side seams and center front and back seams 1 st. in from each edge. Weave the inner leg seams in the same way. Turn under and hem 19 rows on pants legs. Make hem at waist then insert elastic through hem. Pullover: Join side and shoulder seams. Sew short ends of bands together, fold in half then sew 1 edge to inside and 1 to outside of neckline and armholes. Jacket: Join fronts and back at sides and shoulders. Sew sleeves together and set in. Join all sections of bands, fold in half then sew 1 edge to inside and 1 to outside of neckline and front edges. If you like, you can leave openings along the right front for buttonholes. Begin 1" from bottom edge and leave 7/8" of seam open, then repeat every 2 1/2" making 5 buttonholes. Finish buttonholes and sew buttons to the left front.

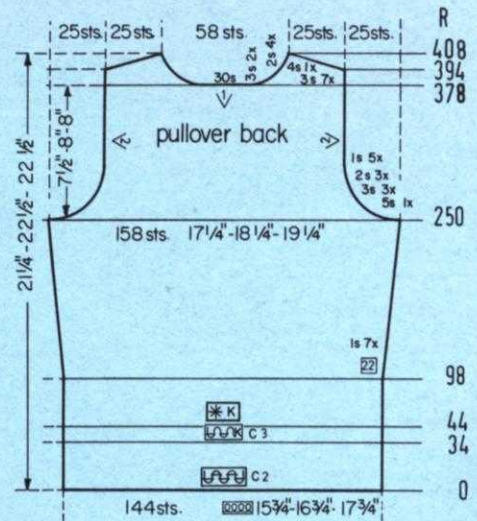

Bring the needles on the left into working position, knit 1 row in Pattern to the LEFT side, turn the Row Counter back to 250 and complete the left half. Follow the instructions from*.

Continue to decrease 1 st on NECK side every 6th row 22x more and SHAPE SHOULDER ON CAM BOX SIDE by binding off 3 sts. after Rows 394, 396, 398, 400, 402, 404, 406; 4 sts. after Row 408.

*Decrease 1 st. OPPOSITE CAM BOX after Rows in () and ON CAM BOX SIDE, bind off 5 sts. after Row 250 (250); 3 sts. after Rows 252, 254 (254), 256; 2 sts. after Rows 258 (258), 260, 262 (262); 1 st. after Rows 264, 266 (266), 268, 270 (270), 272, (274).

Work the Front section the same as the Back section to Row 250, put 79 needles on the left side into holding position and complete the right half first.

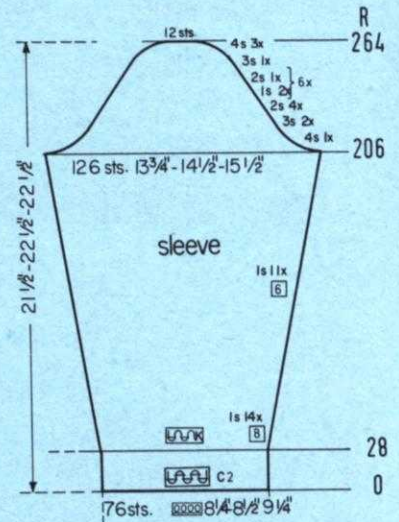
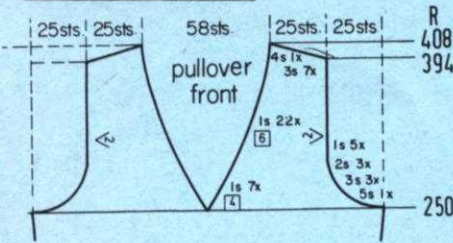

Bring the needles on the left into working position, knit 1 row in Pattern to the left side, turn the Row Counter back to 410 and complete the left half. Follow the instructions from*.

*ON CAM BOX SIDE, bind off 2 sts. after Row 410 (EVEN ROWS = SHOULDER SHAPING); 3 sts. after Row 411 (ODD ROWS = NECK SHAPING); 2 sts. after Row 412; 3 sts. after Rows 413, 414, 415, 416; 2 sts. after Row 417; 3 sts. after Row 418; 2 sts. after Row 419; 3 sts. after Row 420; 2 sts. after Row 421; 3 sts. after Rows 422, 424, 426, 428, 430, 432.

ON CAM BOX SIDE, bind off 4 sts. after Rows 272, 273; 3 sts. after Rows 274, 275, 276, 277; 2 sts. after Rows 278, 279, 280, 281, 282, 283; 1 st. after Rows 284, 285, 286, 287, 288, 289, 290, 291. Knit to Row 410, bind off the center 28 sts., put the needles on the left side into holding position and complete the right half first.

ON EACH SIDE, increase 1 st. after Rows 90, 122, 146, 170, 194, 220, 246, then knit to Row 272.

ROWS 45 to 98: Knit even.

ROWS 35 to 44: Knit even, then change to Pattern.

ROWS 0 to 34: Knit even then change to color 3 and Stockinette stitch.

Cast on 152 sts. with color 2 and work K1, P1 Ribbing.

Cast on 119 sts. with color 2 and work K1, P1 Ribbing. ON OPPOSITE SIDE OF CAM BOX decrease 2 sts. after Rows 2, 4, 6, 8, 10. ON OPPOSITE SIDE OF CAM BOX, increase 2 sts. after Rows 12, 14, 16, 18, 20. After Row 22, bind off all sts. the crochet method for Ribbing.

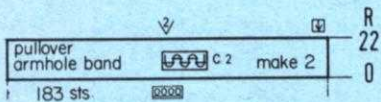
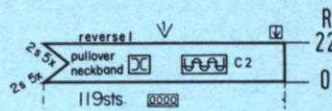

Cast on 183 sts. with color 2 and work 22 rows K1, P1 Ribbing then bind off all sts. the crochet method for Ribbing.

39-40	C-3
37-38	C-1
35-36	C-3
31-34	C-1
29-30	C-2
27-28	C-1
25-26	C-2
21-24	C-1
19-20	C-3
17-18	C-1
15-16	C-3
11-14	C-1
9-10	C-2
7-8	C-1
5-6	C-2
1-4	C-1

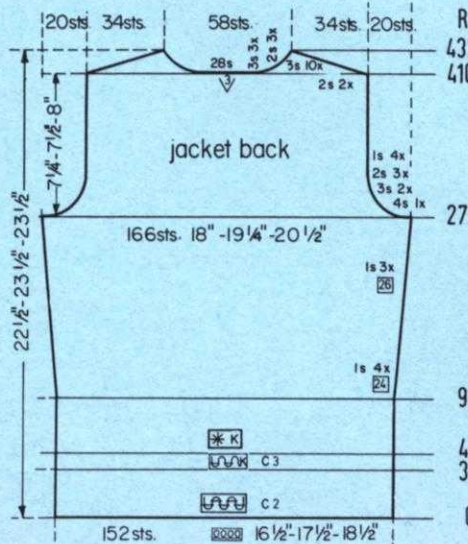

Bring the needles on the left side into working position, knit 1 row in pattern to the left, turn the Row Counter to 378 and complete the left half. Follow the instructions from*.

*ON CAM BOX SIDE, bind off 3 sts. after Rows 379, 381 (ODD ROWS = NECK SHAPING); 2 sts. after Rows 383, 385, 387, 389. Knit to Row 394 and SHAPE SHOULDER ON CAM BOX SIDE by binding off 3 sts. after Rows 394, 396, 398, 400, 402, 404, 406; 4 sts. after Row 408.

ON CAM BOX SIDE, bind off 5 sts. after Rows 250, 251; 3 sts. after Rows 252, 253, 254, 255, 256, 257; 2 sts. after Rows 258, 259, 260, 261, 262, 263; 1 st. after Rows 264, 265, 266, 267, 268, 269, 270, 271, 272, 273. Knit to Row 378, bind off the center 30 sts., put the needles on the left side into holding position and complete the right half first.

ON CAM BOX SIDE increase 1 st. after Rows 98, 120, 142, 164, 186, 208, 230, then knit to Row 250.

ROWS 45 to 98: Knit even.

ROWS 35 to 44: Knit even then change to Pattern.

ROWS 0 to 34: Knit even, then change to color 3 and Stockinette stitch.

Cast on 144 sts. with color 2 and work K1, P1 Ribbing.

ON CAM BOX SIDE, bind off 4 sts. after Rows 206, 207; 3 sts. after Rows 208, 209, 210, 211; 2 sts. after Rows 212, 213, 214, 215, 216, 217, 218, 219; 1 st. after Rows 220, 221, 222, 223; 2 sts. after Rows 224, 225; 1 st. after Rows 226, 227, 228, 229; 2 sts. after Rows 230, 231; 1 st. after Rows 232, 233, 234, 235; 2 sts. after Rows 236, 237; 1 st. after Rows 238, 239, 240, 241; 2 sts. after Rows 242, 243; 1 st. after Rows 244, 245, 246, 247; 2 sts. after Rows 248, 249; 1 st. after Rows 250, 251, 252, 253; 2 sts. after Rows 254, 255; 3 sts. after Rows 256, 257; 4 sts. after Rows 258, 259, 260, 261, 262, 263; 12 sts. after Row 264.

ON EACH SIDE, increase 1 st. after Rows 28, 36, 44, 52, 60, 68, 76, 84, 92, 100, 108, 116, 124, 132, 138, 144, 150, 156, 162, 168, 174, 180, 188, 196, 204.

ROWS 0 to 28: Knit even then change to Stockinette stitch.

Cast on 76 sts. and work K1, P1 Ribbing.

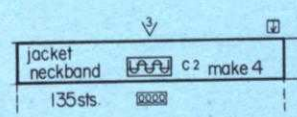

Cast on 137 sts. with color 1 and work 22 rows K1, P1 Ribbing, then bind off all sts. the crochet method for Ribbing. Make 3 more sections the same.

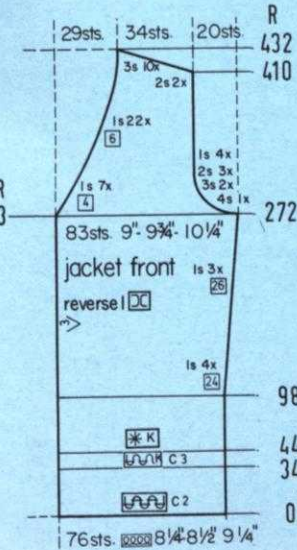

Work the second Front section with reverse shaping.
Continue to decrease 1 st. for Neck every 6th row 22x and SHAPE SHOULDER ON CAM BOX SIDE by binding off 2 sts. after Rows 410, 412; 3 sts. after Rows 414, 416, 418, 420, 422, 424, 426, 428, 430, 432.
Decrease 1 st. OPPOSITE CAM BOX for Neck after Rows in (). ON CAM BOX SIDE, bind off 4 sts. after Row 272 (272); 3 sts. after Rows 274, 276 (276); 2 sts. after Rows 278, 280 (280), 282; 1 st. after Rows 284 (284), 286, 288 (288), 290, (292), (296).
ON CAM BOX SIDE, increase 1 st. after Rows 98, 122, 146, 170, 194, 220, 246, then knit to Row 272.
ROWS 45 to 98: Knit even.
ROWS 35 to 44: Knit even, then change to Pattern.
ROWS 0 to 34: Knit even, then change to Stockinette stitch and color 3.
Cast on 76 sts. with color 2 and work K1, P1 Ribbing.

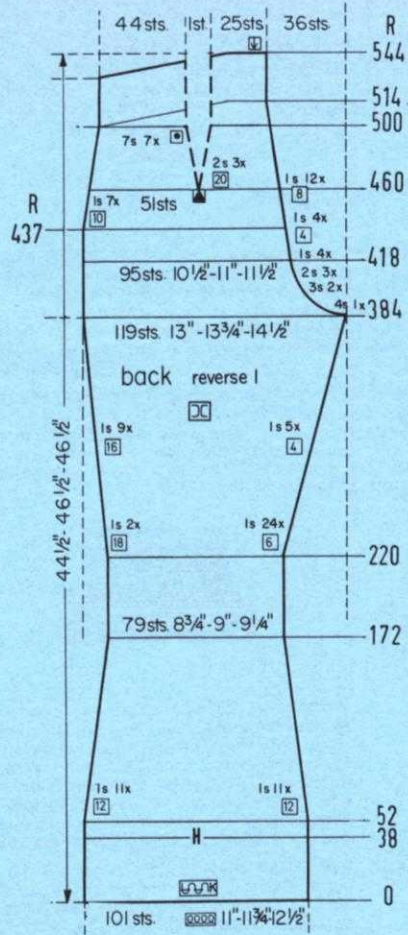

Knit the second back section with reverse shaping, casting on from RIGHT to LEFT. Cam Box will be on the LEFT side at Row 0.

ON CAM BOX SIDE, decrease 1 st. after Row 500 and work Short Rows on OPPOSITE SIDE OF CAM BOX. Put 7 needles into holding position after Rows 500, 502, 504, 506; decrease 1 st. ON CAM BOX SIDE after Row 508 and put 7 needles OPPOSITE CAM BOX into holding position after Rows 508, 510, 512. After Row 514, bring all the needles back into working position and knit to Row 544, then bind off the remaining sts.

Decrease 2 sts. for DART after Rows in (), the first time hang the 51st and 53rd sts. onto the 52nd needle, counting from the left edge. The following DART decreases lie directly above. ON CAM BOX SIDE, decrease 1 st. after Rows 420, 428, 436, (437), 444, (447), 452, (457), 460, (467), 468, 476, (477), 484, (487), 492, (497).

ON CAM BOX SIDE, bind off 4 sts. after Row 384 (increase 1 st. after Row 385); 3 sts. after Rows 386, 388; 2 sts. after Rows 390, 392, 394; 1 st. after Rows 396, 398, 400, 402, 404, 408, 412, 416.

ON CAM BOX SIDE, increase 1 st. after Rows 220 (EVEN ROWS = INNER LEG), 221 (ODD ROWS = SIDE EDGE), 226, 232, 238, 239, 244, 250, 256, 257, 262, 268, 273, 274, 280, 286, 289, 292, 298, 304, 305, 310, 316, 321, 322, 328, 334, 337, 340, 346, 352, 353, 358, 364, 368, 369, 372, 376, 380. Knit to Row 384.

ROWS 173 to 220: Knit even.

ON EACH SIDE, decrease 1 st. after Rows 52, 64, 76, 88, 100, 112, 124, 136, 148, 160, 172.

ROWS 0 to 52: Knit even.

Cast on 101 sts. with color 1 and work Stockinette stitch.

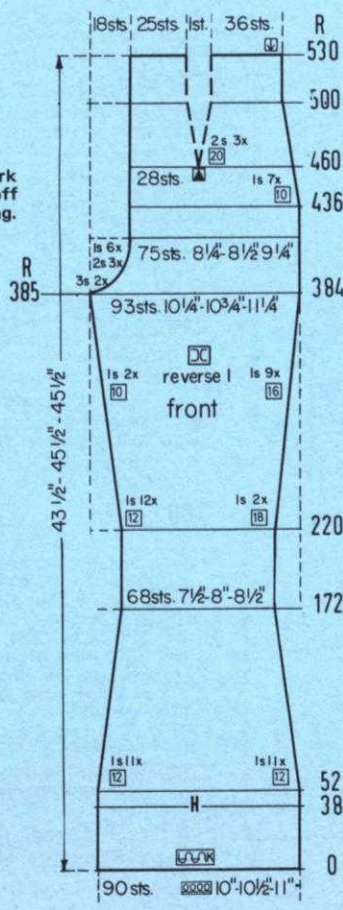

Knit the second Front section with reverse shaping, casting on from RIGHT to LEFT. Cam Box will be on the LEFT side at Row 0.

Decrease 2 sts. for DART after Rows in (), the first time, hang the 28th and 30th sts. onto the 29th st. The following DART decreases lie directly above. ON CAM BOX SIDE, decrease 1 st. after Rows 436, 446, 456, (460), 466, 476, (480), 486, 496, (500). Knit to Row 530 then bind off the remaining sts.

ON CAM BOX SIDE, bind off 3 sts. after Rows 385, 387; 2 sts. after Rows 389, 391, 393; 1 st. after Rows 395, 397, 399, 401, 403, 405. Knit to Row 436.

Increase 1 st. after Rows 220 (EVEN ROWS = SIDE EDGE), 221 (ODD ROWS = INNER LEG), 233, 238, 245, 256, 257, 269, 272, 281, 288, 293, 304, 305, 317, 320, 329, 336, 341, 352, 353, 365, 368, 375, 384.

ON EACH SIDE, decrease 1 st. after Rows 52, 64, 76, 88, 100, 112, 124, 136, 148, 160, 172. Knit to Row 220.

ROWS 0 to 52: Knit even.

Cast on 90 sts. with color 1 and work Stockinette stitch.

DK 8343

SIZE:	16 (Bust 37"-38")	18 (Bust 39"-40")	20 (Bust 41"-42")
YARN:	Subita Crepe C-1 Melodie C-2	Subita Crepe C-1 Melodie C-2	Regia C-1 Melodie C-2
50 gr. BALLS:	Dress 14 C-1 Jacket 4 C-1 3 C-2	15 C-1 5 C-1 3 C-2	16 C-1 6 C-1 4 C-2
TENSION:	4 to 6	5 to 7	5 to 7
GAUGE:	2" Stk. 17 sts. 22 rows Pattern 17 sts. 36 rows	16 sts. 21 rows 16 sts. 34 rows	15 sts. 20 rows 15 sts. 32 rows

1 20" Zipper

The instructions are the same for all sizes. DRESS: Stockinette stitch. JACKET: Weaving Pattern with the Weaving Attachment and using Cam Wheel No. 6 according to the Line Drawing. The Purl side is the right side. Dress DECREASES: Hang the 3rd sts. onto the 2nd st. then move the end st. in to fill the empty needle. Dress INCREASES: Move the 2 end sts. 1 needle outward then place the 3rd st. from the row below onto the empty needle. To form the hem, hang the cast on sts. back onto the machine behind the latches. Make Jacket increases and decreases on the edge.

FINISHING: Block all sections. DRESS: Join the center back seam up to the zipper opening. Join the front and back sections at sides and shoulders. Sew 1 edge of neckband to the outside and 1 to the inside of neckline. Crochet 1 row of single crochet around back opening and sew in zipper. Sew the sleeves together and set in. JACKET: Join the back and front sections at sides and shoulders. Sew the sleeves together and set in. Sew neckband to jacket, then sew front bands, 1 edge to inside and 1 to the outside.

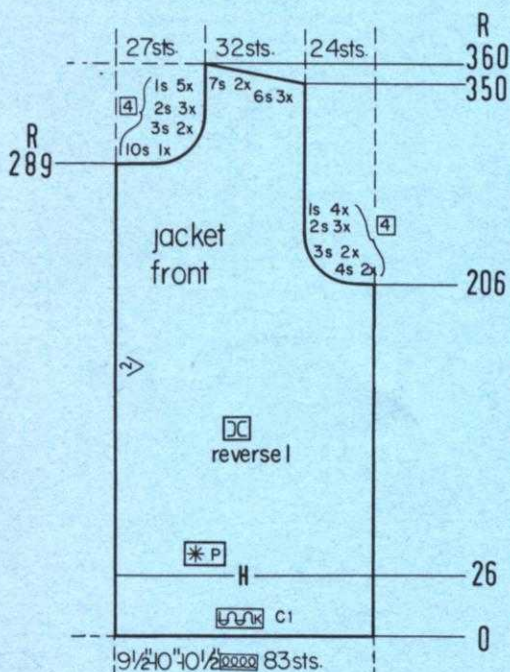

Work the second front section with reverse shaping. Cast on in the regular way, knit the 26 rows Stockinette stitch, form the hem, then begin the Weaving Pattern. Knit 1 row to the left side, turn the Row Counter to 26 and follow the instructions as written (Cam Box will be on the LEFT on even numbered rows).

ON CAM BOX SIDE, bind off 10 sts. after Row 289; 3 sts. after Rows 293, 297; 2 sts. after Rows 301, 305, 309; 1 st. after Rows 313, 317, 321, 325, 329, then knit to Row 350. For Shoulder, bind off 6 sts. after Rows 350, 352, 354; 7 sts. after Rows 356, 358.

ON CAM BOX SIDE, bind off 4 sts. after Rows 206, 210; 3 sts. after Rows 214, 218; 2 sts. after Rows 222, 226, 230; 1 st. after Rows 234, 238, 242, 246, then knit to Row 289.

ROWS 27 to 206: Knit even.

ROWS 0 to 26: Knit even, then form the hem and change to Weaving Pattern Stitch.

Cast on 83 sts. with color 1 and work Stockinette stitch.

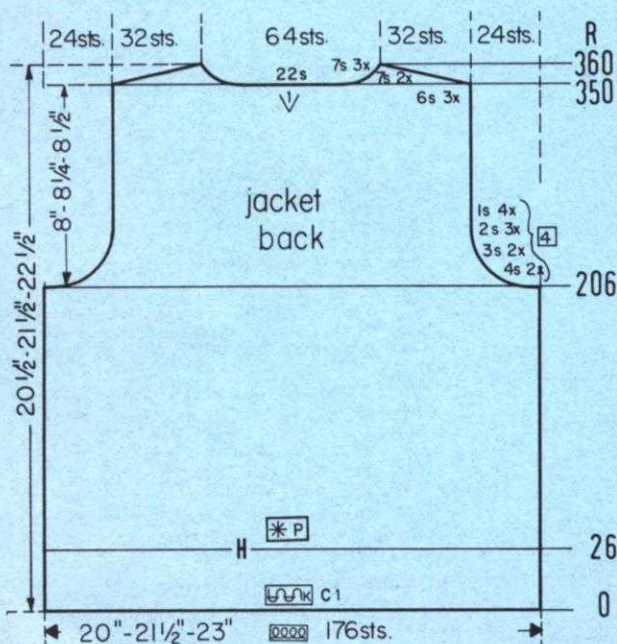

Bring the needles on the left side into working position, knit 1 row in Pattern to the left side, turn the Row Counter back to 350 and complete the left half. Follow the instructions from*.

*ON CAM BOX SIDE, bind off 6 sts. after Row 350 (EVEN ROWS = SHOULDER SHAPING); 7 sts. after Row 351 (ODD ROWS = NECK SHAPING); 6 sts. after Row 352; 7 sts. after Row 353; 6 sts. after Row 354; 7 sts. after Rows 355, 356, 358.

ON CAM BOX SIDE, bind off 4 sts. after Rows 206, 207, 210, 211; 3 sts. after Rows 214, 215, 218, 219; 2 sts. after Rows 222, 223, 226, 227. ON EACH SIDE, decrease 1 st. after Rows 230, 234, 238, 242, then knit to Row 350. Bind off the center 22 sts., put the needles on the left side into holding position and complete the right half first.

ROWS 27 to 206: Knit even.

ROWS 0 to 26: Knit even, then form the hem and change to the Weaving Pattern Stitch.

Cast on 176 sts. with color 1 and work Stockinette stitch.

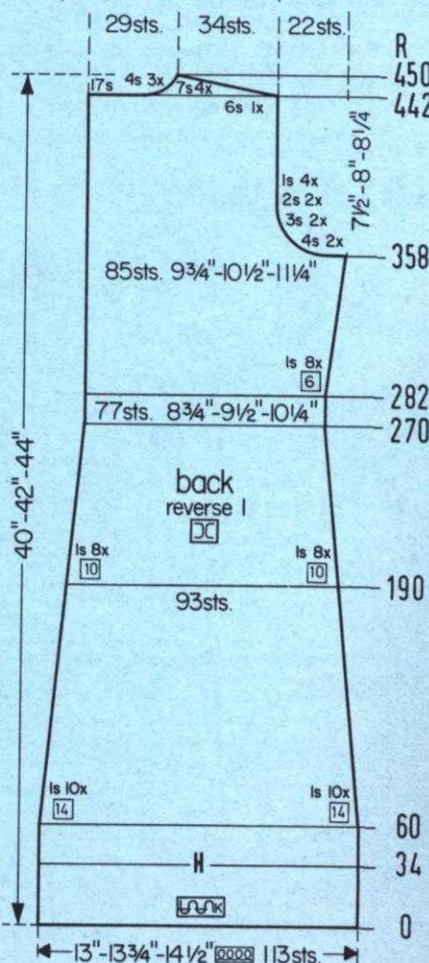
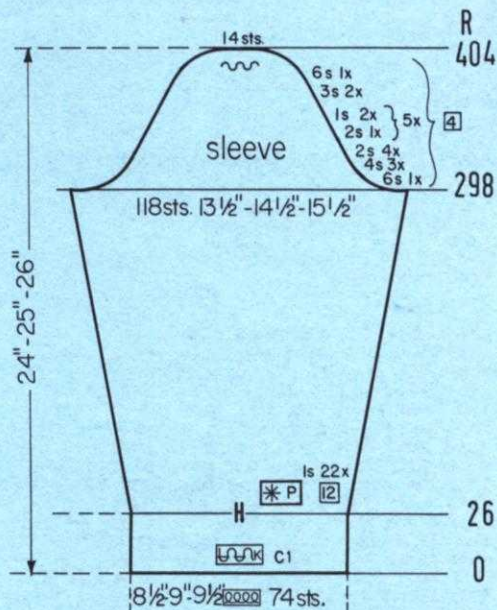

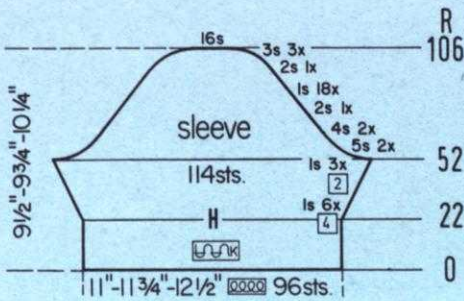

R
106 ON CAM BOX SIDE, bind off 5 sts. after Rows 52, 53, 54, 55; 4 sts. after Rows 56, 57, 58, 59; 2 sts. after Rows 60, 61; 1 st. after Rows 62 through 97; 2 sts. after Rows 98, 99; 3 sts. after Rows 100, 101, 102, 103, 104, 105; 16 sts. after Row 106.

52 ON EACH SIDE, increase 1 st. after Rows 22, 26, 30, 34, 38, 42, 46, 48, 50, then knit to Row 52.

22 ROWS 0 to 22: Knit even, then form the hem.

0 Cast on 96 sts. and work Stockinette stitch.

Move the Cam Box to the left side, turn the Row Counter back to 158 and complete the left half. Follow the instructions from*.

*ON CAM BOX SIDE, bind off 3 sts. after Rows 159, 161, 163; 2 sts. after Rows 165, 167, 169; 1 st. after Rows 171, 173, 175, 177, then knit to Row 188. For Shoulder, bind off 6 sts. after Row 188; 7 sts. after Rows 190, 192, 194, 196.

ON CAM BOX SIDE, bind off 6 sts. after Rows 298, 299; 4 sts. after Rows 302, 303, 306, 307, 310, 311; 2 sts. after Rows 314, 315, 318, 319, 322, 323, 326, 327; 1 st. after Rows 330, 331, 334, 335; 2 sts. after Rows 338, 339; 1 st. after Rows 342, 343, 346, 347; 2 sts. after Rows 350, 351; 1 st. after Rows 354, 355, 360, 361; 2 sts. after Rows 364, 365; 1 st. after Rows 370, 371, 374, 375; 2 sts. after Rows 380, 381; 1 st. after Rows 384, 385, 388, 389; 2 sts. after Rows 392, 393; 3 sts. after Rows 396, 397, 400, 401; 6 sts. after Row 404.

ON EACH SIDE, increase 1 st. after Rows 26, 38, 50, 62, 74, 86, 98, 110, 122, 134, 146, 158, 170, 182, 194, 206, 218, 230, 242, 254, 266, 278 then knit to Row 298.

ROWS 0 to 26: Knit even, then form the hem and change to the Weaving Pattern Stitch.*

Cast on 74 sts. with color 1 and work Stockinette stitch.

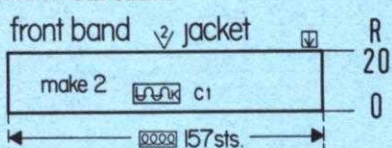

Cast on 157 sts. with color 1 and work 20 rows Stockinette stitch then bind off all sts.

Work second back section with reverse shaping, casting on from RIGHT to LEFT. Cam Box will be on the LEFT side at Row 0.

ON CAM BOX SIDE, bind off 6 sts. after Row 442 (EVEN ROWS = SHOULDER SHAPING); 17 sts. after Row 443 (ODD ROWS = NECK SHAPING); 7 sts. after Row 444; 4 sts. after Row 445; 7 sts. after Row 446; 4 sts. after Row 447; 7 sts. after Row 448; 4 sts. after Row 449; 7 sts. after Row 450.

ON CAM BOX SIDE, bind off 4 sts. after Rows 358, 360; 3 sts. after Rows 362, 364; 2 sts. after Rows 366, 368; 1 st. after Rows 370, 372, 374, 376, then knit to Row 442.

ON CAM BOX SIDE increase 1 st. after Rows 282, 288, 294, 300, 306, 312, 318, 324, then knit to Row 358.

ON EACH SIDE, decrease 1 st. after Rows 60, 74, 88, 102, 116, 130, 144, 158, 172, 186, 200, 210, 220, 230, 240, 250, 260, 270, then knit to Row 282.

ROWS 0 to 34: Knit even, then form the hem.

Cast on 113 sts. and work Stockinette stitch.

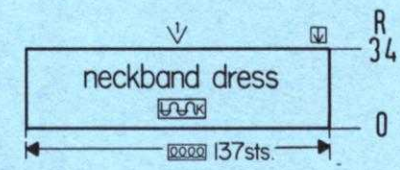
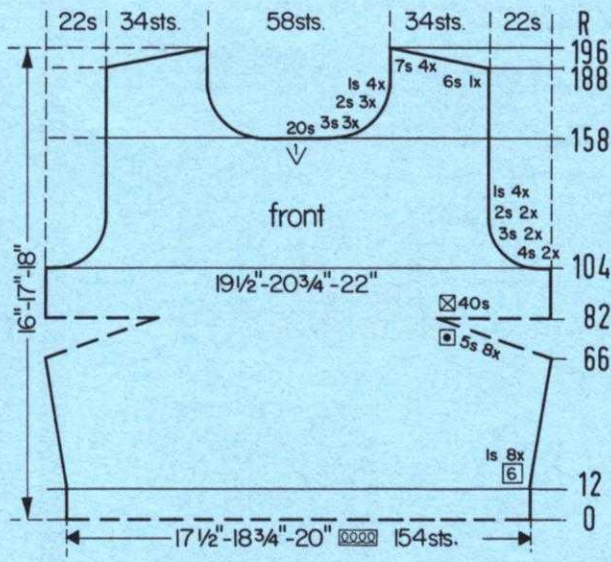

Cast on 137 sts. and work 34 rows Stockinette stitch, then bind off all sts.

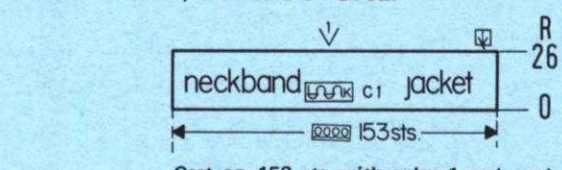

Cast on 153 sts. with color 1 and work 26 rows Stockinette stitch then bind off all sts.

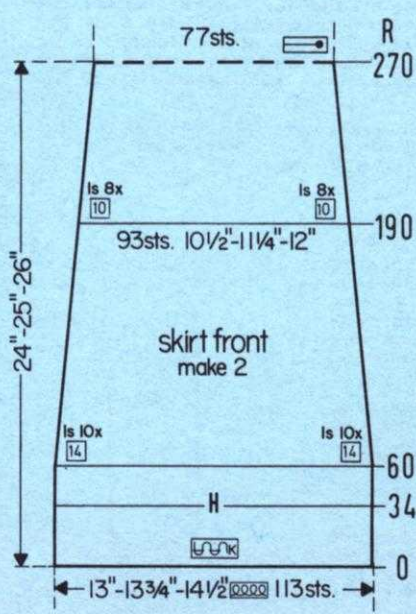

Work the second front skirt section with reverse shaping, casting on from RIGHT to LEFT. Cam Box will be on the LEFT side at Row 0.

ON EACH SIDE, decrease 1 st. after Rows 60, 74, 88, 102, 116, 130, 144, 158, 172, 186, 200, 210, 220, 230, 240, 250, 260, 270, then with contrast waste yarn, knit 10 rows and drop the work from the machine.

ROWS 0 to 34: Knit even, then form the hem.

Cast on 113 sts. and work Stockinette stitch.

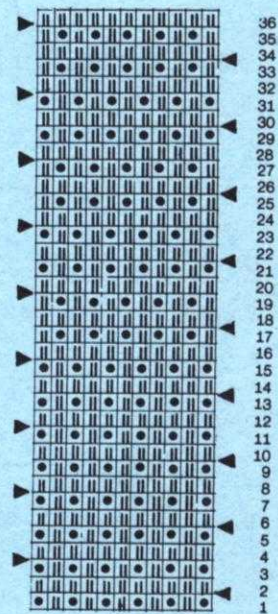

KG 1984 PATCHWORK BLANKET AND PILLOWS



SIZE
BLANKET: Approximately 84" x 100"
YARN: Flamingo Dralon
50 gr. BALLS:
 4 C-1, 3 C-2, 4 C-3, 10 C-4, 4 C-5, 4 C-6,
 5 C-7, 5 C-8, 5 C-9, 4 C-10, 4 C-11, 4 C-12.

TENSION: 9 to 10
GAUGE: 2" 13 sts. 18 rows

The Blanket is made using Stockinette stitch in 8 strips with 10 sections in each strip. The Border bands are Stockinette stitch with Short Rows. The instructions are given for the bands to be made separately but you CAN knit the bands all in one piece using the same method as in KG 1981, Volume 10 No. 5 KNITTING MAGAZINE - see Practical Knitting Hints in that issue.

FINISHING: Block all sections. **BLANKET:** Sew the 8 strips together. Join Bands at mitered corners then sew 1 edge of band to the inside and 1 to the outside of blanket, matching corners. **PILLOW A:** Join sections together leaving an opening for pillow. Insert Pillow form then close opening. **PILLOW B:** Cut 2 circles of fabric 20" in diameter. Make a circle of the cord and sew onto the fabric going around and around until the circle is covered. Join both pieces together, insert pillow and close opening.

								R
								850
C9	C4	C10	C12	C7	C10	C2	C6	765
C3	C11	C9	C10	C3	C7	C11	C12	680
C7	C2	C3	C5	C4	C5	C4	C8	595
C6	C8	C6	C7	C12	C3	C7	C4	510
C8	C11	C12	C4	C9	C1	C2	C10	425
C5	C7	C5	C8	C10	C6	C11	C1	340
C12	C3	C1	C6	C1	C4	C5	C9	255
C9	C10	C7	C1	C5	C9	C8	C7	170
C4	C11	C8	C3	C6	C12	C11	C5	85
C1	C2	C4	C9	C4	C8	C2	C3	0

PATCHWORK BLANKET
 Make 8 strips. Cast on 67 sts. and work even in Stockinette stitch following the color changes as shown in the Line Drawing. After Row 850, bind off all sts.

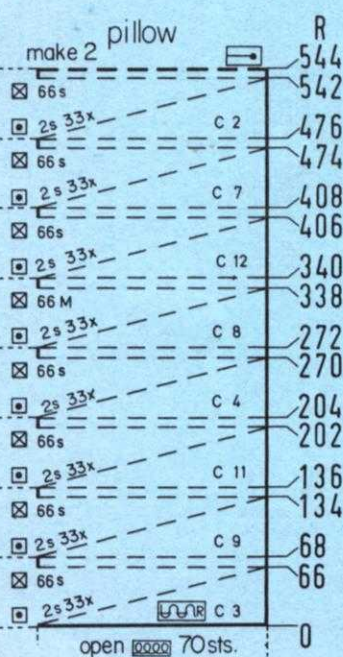

PILLOW A
 *ON OPPOSITE SIDE OF CAM BOX, put 2 needles into holding position every other row 33x. Push all the needles back into working position, knit 2 rows. REPEAT from * 7x more. With waste yarn, knit 8 rows and drop the work from the machine. Make another section the same.
 Open cast-on 70 sts. with waste yarn. Knit 8 rows, turn the Row Counter to 0 and change to color 3 then work Short Rows and color changes as shown on Chart.
PILLOW B
 Make a cord over 5 needles using tension 1 to 3. Change colors, increasing the amount of rows of each color so that each color will make a complete circle - see Picture.

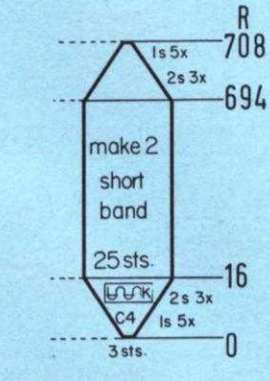

SHORT BAND
 ON OPPOSITE SIDE OF CAM BOX, put into holding position 2 needles before knitting the next 6 rows, then 1 needle before knitting the next 10 rows. After Row 708, bring all the needles into working position and bind off all sts. Make a second section the same.
 ROWS 17 to 694: Knit even.
 Knit 2 rows over the 3 needles in working position (be sure to wrap the yarn). ON OPPOSITE SIDE OF CAM BOX, bring back into working position 1 needle before knitting the next 10 rows; 2 needles before knitting the next 6 rows.
 Cast on 25 sts. with color 4. Put all but the center 3 sts. into holding position, then work Short Rows.

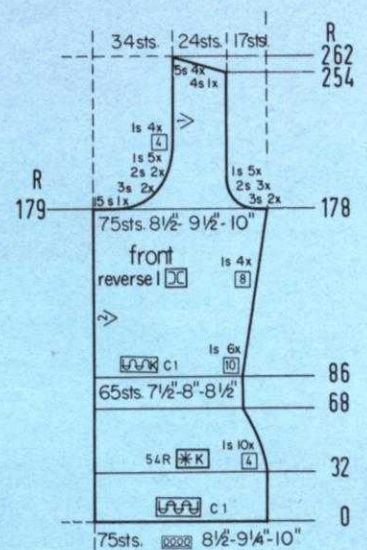

Cast on 141 sts. with color 1 and work 24 rows K1, P1 Ribbing, then bind off all sts.

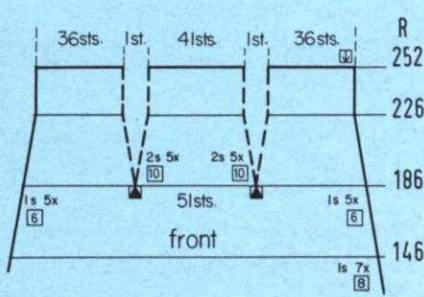
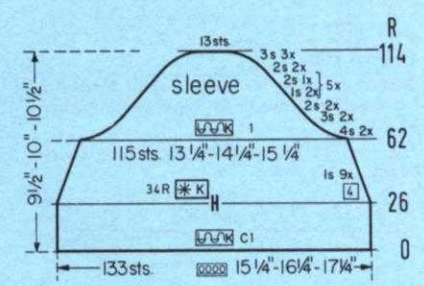

LONG BAND
 ON OPPOSITE SIDE OF CAM BOX, put into holding position 2 needles before knitting the next 6 rows, then 1 needle before knitting the next 10 rows. After Row 882, bring all the needles into working position and bind off all sts. Make a second section the same.
 ROWS 17 to 866: Knit even.
 Knit 2 rows over the 3 needles in working position (be sure to wrap the yarn). ON OPPOSITE SIDE OF CAM BOX, bring back into working position, 1 needle before knitting the next 10 rows, 2 needles before knitting the next 6 rows.
 Cast on 25 sts. with color 4. Put all but the center 3 sts. into holding position, then work Short Rows.

DKS172

Work the second front section with reverse shapings, casting on from right to left. (Cam Box will be on the LEFT side at Row 0).

ON CAM BOX SIDE, bind off 3 sts. after Row 178 (EVEN ROWS = ARM-HOLE SHAPING); 15 sts. after Row 179 (ODD ROWS = NECK SHAPING); 3 sts. after Rows 180, 181; 2 sts. after Row 182; 3 sts. after Row 183; 2 sts. after Rows 184, 185, 186, 187; 1 st. after Rows 188, 189, 190, 191, 192, 193, 194, 195, 196, 197, 199, 203, 207, 211. For SHOULDER bind off 4 sts. after Row 254; 5 sts. after Rows 256, 258, 260, 262.

ON CAM BOX SIDE, increase 1 st. after Rows 86, 96, 106, 116, 126, 136, 146, 154, 162, 170, then knit to Row 178.

ON CAM BOX SIDE, decrease 1 st. after Rows 32, 36, 40, 44, 48, 52, 56, 60, 64, 68, then knit to Row 86, continue with color 1 and work Stockinette stitch.

ROWS 0 to 32: Knit even, then change to Stockinette stitch and work the Norwegian Design.

Cast on 75 sts. with color 1 and work K1, P1 Ribbing.

ON CAM BOX SIDE, bind off 4 sts. after Rows 62, 63, 64, 65; 3 sts. after Rows 66, 67, 68, 69; 2 sts. after Rows 70, 71, 72, 73; 1 st. after Rows 74, 75, 76, 77; 2 sts. after Rows 78, 79; 1 st. after Rows 80, 81, 82, 83; 2 sts. after Rows 84, 85; 1 st. after Rows 86, 87, 88, 89; 2 sts. after Rows 90, 91; 1 st. after Rows 92, 93, 94, 95; 2 sts. after Rows 96, 97; 1 st. after Rows 98, 99, 100, 101; 2 sts. after Rows 102, 103, 104, 105, 106, 107; 3 sts. after Rows 108, 109, 110, 111, 112, 113; 13 sts. after Row 114.

ON EACH SIDE, decrease 1 st. after Rows 26, 30, 34, 38, 42, 46, 50, 54, 58, then knit to Row 62.

ROWS 0 to 26: Knit even, then form the hem and begin the Norwegian Design.

Cast on 133 sts. with color 1 and work Stockinette stitch.

Decrease 2 sts. for EACH DART after Rows in (). Continue to decrease 1 st. ON EACH SIDE after Rows 146, 154, 162, 170, 178, 186 (186), 194, (196), 202, (206), 208, 214, (216), 220, 226 (226), then knit to Row 252 and bind off the remaining 115 sts.

Work the front section the same as the back section to ROW 146.

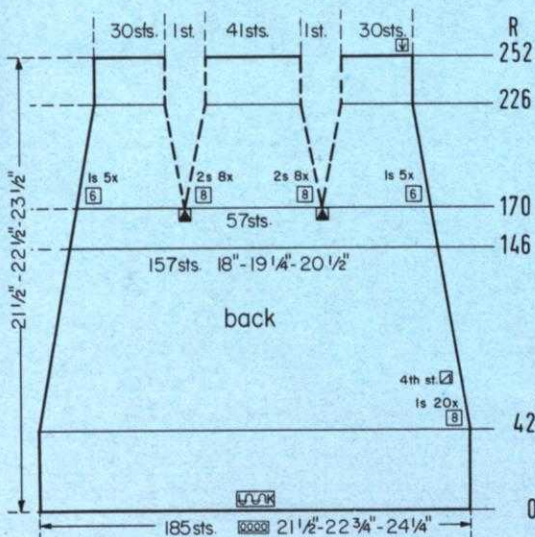

SIZE:	10 (Bust 32"-33")	12 (Bust 34"-35")	16 (Bust 37"-38")
YARN:	Beatrice Crepe	Beatrice Crepe	Melodie
50 gr. BALLS:			
Skirt:	7 color 1	7 color 1	9 color 1
Jacket:	7 color 1	7 color 1	9 color 1
	1 color 2	1 color 2	2 color 2
	1 color 3	1 color 3	1 color 3
	1 color 4	1 color 4	1 color 4
TENSION:	4 to 6	5 to 7	6 to 8
GAUGE:	2"	17 sts. 23 rows	16 sts. 22 rows
6 Buttons			15 sts. 21 rows

The instructions are the same for all sizes. PATTERN: SKIRT: Stockinette stitch. JACKET: Stockinette stitch and Norwegian Design Borders according to the Line Drawing, or use JAC 40 with Norwegian Pattern of your choice: In the instructions, each row in the Norwegian Design is counted as 1 row, but several movements of the Cam Box are needed to complete 1 row. BANDS: K1, P1 Ribbing. DECREASES: SKIRT: Hang the 4th st. onto the 3rd st., then move the end sts. inward to fill the empty needles. Begin the Darts by hanging the sts. together as marked on the Diagrams, then move the sts. together to fill the empty needles. The following decreases for the Darts lie directly above. JACKET: Hang the 1st st. onto the 2nd st. INCREASES: Move the 2 end sts. 1 needle outward, then place the 3rd st. from the row below onto the empty needle. While working the Norwegian Design, place the end st. from the row below onto the next empty needle.

FINISHING: Block all sections. SKIRT: Weave the sections together at sides, 1 st. in from each edge. Turn under 18 rows on lower edge and 13 rows on upper edge and hem to wrong side. Insert an elastic band into the upper hem. JACKET: Join back and front sections at sides and shoulders. Sew the sleeves together and set in. Sew 1 edge of 1 front band to the inside and 1 edge to the outside of the left front edge. Sew the other front band to the right front edge in the same manner, leaving 6 3/4" spaces for buttonholes. Begin the first buttonhole space about 1" from the lower edge. The following spaces are about 2 1/4" apart. Join the neckband sections at center back, then sew 1 edge of the band to inside and 1 edge to the outside of the neckline. Finish the buttonholes, sew on buttons.



Move the Cam Box to the left side, turn the Row Counter back to 240 and complete the left half. Follow the instructions from*.

*ON CAM BOX SIDE, bind off 4 sts. after Rows 241, 243 (ODD ROWS = NECK SHAPING); 3 sts. after Rows 245, 247; 2 sts. after Rows 249, 251; 1 st. after Row 253; 4 sts. after Row 254 (EVEN ROWS = SHOULDER SHAPING); 1 st. after Row 255; 5 sts. after Rows 256, 258, 260, 262.

ON CAM BOX SIDE, bind off 3 sts. after Rows 178, 179, 180, 181; 2 sts. after Rows 182, 183, 184, 185, 186, 187; 1 st. after Rows 188, 189, 190, 191, 192, 193, 194, 195, 196, 197, then knit to Row 240, bind off the center 28 sts., put the needles on the left side into holding position and complete the right half first.

ON EACH SIDE, increase 1 st. after Rows 86, 96, 106, 116, 126, 136, 146, 154, 162, 170, then knit to Row 178.

ON EACH SIDE, decrease 1 st. after Rows 32, 36, 40, 44, 48, 52, 56, 60, 64, 68, then knit to Row 86, continue with color 1 and work Stockinette stitch.

ROWS 0 to 32: Knit even, then change to Stockinette stitch and work the Norwegian Design.

Cast on 150 sts. with color 1 and work K1, P1 Ribbing.

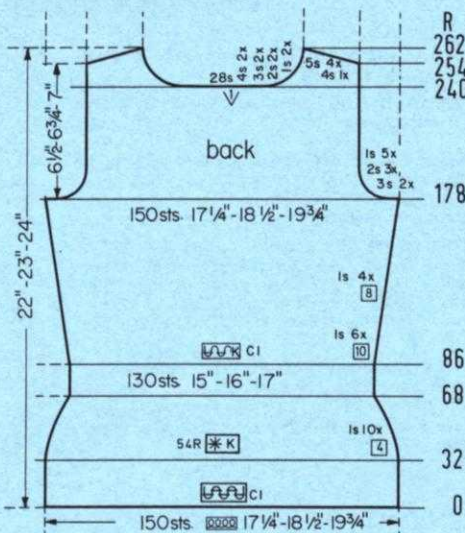

Decrease 2 sts. for EACH DART after Rows in (). ON EACH SIDE, decrease 1 st. after Rows 42, 50, 58, 66, 74, 82, 90, 98, 106, 114, 122, 130, 138, 146, 154, 162, 170 (170), 178 (178), 186 (186), 194 (194), 202 (202), 208, (210), 214, (218), 220, 226 (226), then knit to Row 252 and bind off the remaining 103 sts. (Work the Front Section the same to Row 146, but do not decrease after Row 146).

ROWS 0 to 42: Knit even.

Cast on 185 sts. with color 1 and work Stockinette stitch.

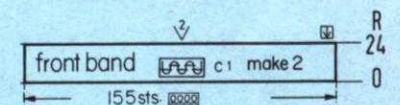

Cast on 155 sts. with color 1 and work 24 rows K1, P1 Ribbing, then bind off all sts.

KK5-118

SIZE:	4 (Chest 23")	6 (Chest 24")	8 (Chest 26")
YARN:	Beatrice Crepe	Beatrice Crepe	Crocus Crepe
50 gr. BALLS:			
Pullover:	4	4	6
Vest:	2 color 1 1 color 2 1 color 3 2 color 4	2 color 1 1 color 2 1 color 3 2 color 4	3 color 1 2 color 2 1 color 3 2 color 4
TENSION:	4 to 6	5 to 7	6 to 8
GAUGE:	2" 17 sts. 23 rows	16 sts. 22 rows	15 sts. 21 rows
	1 Button		

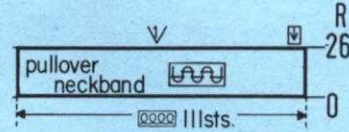
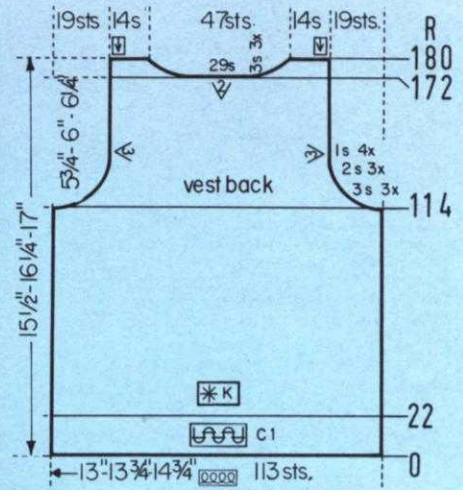

Cast on 111 sts. and work 26 rows K1, P1 Ribbing, then bind off all sts.

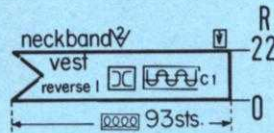
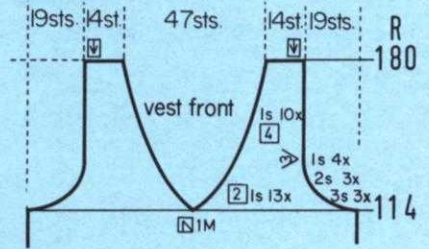

Cast on 93 sts. with color 1, work K1, P1 Ribbing and Short Rows. ON OPPOSITE SIDE OF CAM BOX put into holding position 2 needles after Rows 2, 4, 6, 8, 10, then bring back into working position 2 needles after Rows 12, 14, 16, 18, 20. After Row 22 bind off all sts. Work the second neckband section with reverse shaping, casting on from right to left. (Cam Box will be on the LEFT side at Row 0).

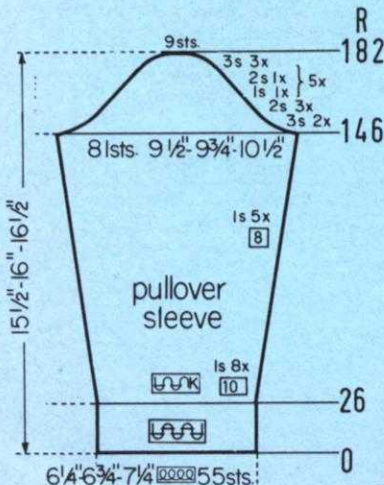
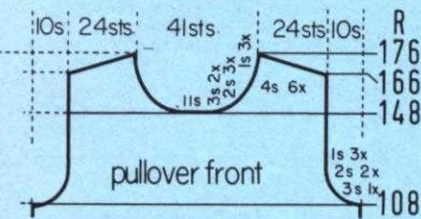
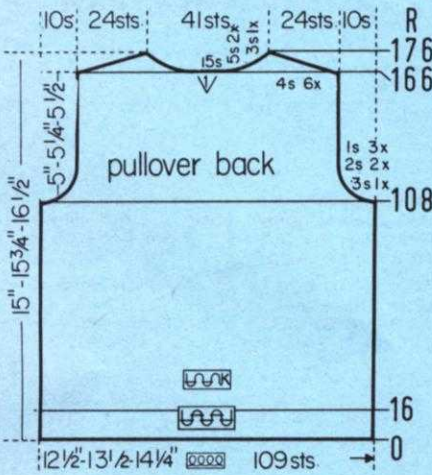

Move the Cam Box to the left side, turn the Row Counter back to 166 and complete the left half. Follow the instructions from*.

*ON CAM BOX SIDE, bind off 4 sts. after Row 166 (EVEN ROWS = SHOULDER SHAPING); 5 sts. after Row 167 (ODD ROWS = NECK SHAPING); 4 sts. after Row 168; 5 sts. after Row 169; 4 sts. after Row 170; 3 sts. after Row 171; 4 sts. after Rows 172, 174, 176.

ON CAM BOX SIDE, bind off 3 sts. after Rows 108, 109; 2 sts. after Rows 110, 111, 112, 113; 1 st. after Rows 114, 115, 116, 117, 118, 119, then knit to Row 166, bind off the center 15 sts., put the needles on the left side into holding position and complete the right half first. (For the Front Section, knit to ROW 148).

ROWS 17 to 108: Knit even.

ROWS 0 to 16: Knit even, then change to Stockinette stitch.

Cast on 109 sts. and work K1, P1 Ribbing.

Move the Cam Box to the left side, turn the Row Counter back to 148 and complete the left half. Follow the instructions from*.

*ON CAM BOX SIDE, bind off 3 sts. after Rows 149, 151; 2 sts. after Rows 153, 155, 157; 1 st. after Rows 159, 161, 163. For SHOULDER bind off 4 sts. after Rows 166, 168, 170, 172, 174, 176.

Work the front section the same as the back section to ROW 148, then bind off the center 11 sts., put the needles on the left side into holding position and complete the right half first.

ON CAM BOX SIDE, bind off 3 sts. after Rows 146, 147, 148, 149; 2 sts. after Rows 150, 151, 152, 153, 154, 155; 1 st. after Rows 156, 157; 2 sts. after Rows 158, 159; 1 st. after Rows 160, 161; 2 sts. after Rows 162, 163; 1 st. after Rows 164, 165; 2 sts. after Rows 166, 167; 1 st. after Rows 168, 169; 2 sts. after Rows 170, 171; 1 st. after Rows 172, 173; 2 sts. after Rows 174, 175; 3 sts. after Rows 176, 177, 178, 179, 180, 181; 9 sts. after Row 182.

ON EACH SIDE, increase 1 st. after Rows 26, 36, 46, 56, 66, 76, 86, 96, 106, 114, 122, 130, 138, then knit to Row 146.

ROWS 0 to 26: Knit even, then change to Stockinette stitch.

Cast on 55 sts. and work K1, P1 Ribbing.

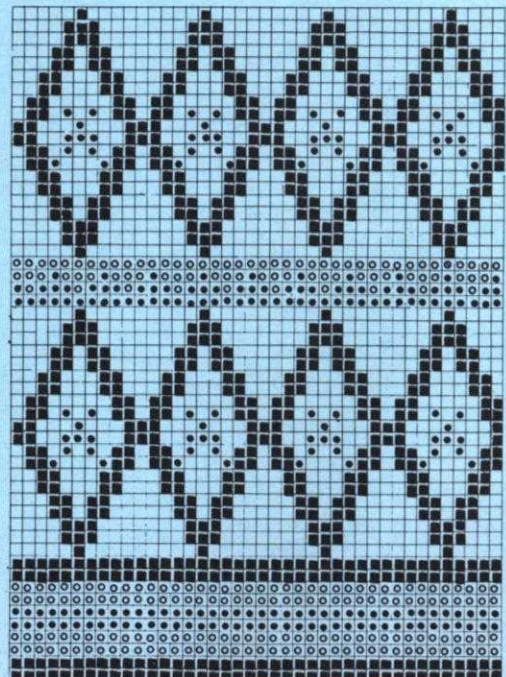

- color 1
- color 2
- color 3
- ◐ color 4

MK 5503



Bring the needles on the left side into working position, knit 1 row in PATTERN to the left side, turn the Row Counter back to 172 and complete the left half. Follow the instructions from*.

*ON CAM BOX SIDE, bind off 3 sts. after Rows 173, 175, 177. After Row 180 bind off the 14 Shoulder sts.

ON CAM BOX SIDE, bind off 3 sts. after Rows 114, 115, 116, 117, 118, 119; 2 sts. after Rows 120, 121, 122, 123, 124, 125; 1 st. after Rows 126, 127, 128, 129, 130, 131, 132, 133, then knit to Row 172, bind off the center 29 sts., put the needles on the left side into holding position and complete the right half first.

ROWS 23 to 114: Knit even.

ROWS 0 to 22: Knit even, then change to Stockinette stitch and work the Norwegian Design.

Cast on 113 sts. with color 1 and work K1, P1 Ribbing.

Bring the needles on the left side into working position, turn the Row Counter back to 114 and complete the left half. Follow the instructions from*.

*Decrease 1 st. ON NECK SIDE after Rows in (). ON CAM BOX SIDE, bind off 3 sts. after Rows 114, 116 (116), 118 (118); 2 sts. after Rows 120 (120), 122 (122), 124; (124), 1 st. after Rows 126 (126), 128 (128), 130 (130), 132 (132). The Armhole Shaping is now completed. Continue to decrease 1 st. ON NECK SIDE after Rows 134, 136, 138, 140, 142, 144, 148, 152, 156, 160, 164, 168, 172, 176. After Row 180 bind off the 14 Shoulder sts.

Work the front section the same as the back section to ROW 114, then transfer the center st. onto the neighboring needle, put the needles on the left side into holding position and complete the right half first.

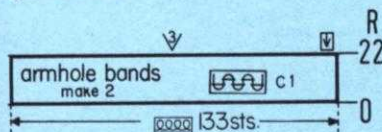

Cast on 133 sts. with color 1 and work 22 rows K1, P1 Ribbing, then bind off all sts.

SIZE:	6 (Chest 24"-25")	8 (Chest 26"-27")	10 (Chest 28"-29")
YARN:	Regia	Allegro	Allegro
50 gr. BALLS:	5 C-1 1 C-2 1 C-3	5 C-1 1 C-2 1 C-3	6 C-1 1 C-2 1 C-3
TENSION:	4 to 6	4 to 6	6 to 8
GAUGE:	2" 16 sts. 24 rows	15 sts. 23 rows	14 sts. 20 rows

The instructions are the same for all sizes. PATTERN: Stockinette stitch with color stripes on sleeves according to the Chart. EDGES: K1, P1 Ribbing. DECREASES: Hang the 3rd st. onto the 2nd needle and move the sts. in to fill the empty needle. INCREASES: Move the 2 end sts. 1 needle outward, then pick up the 3rd st. from the row below and hang it onto the empty needle.

FINISHING: Block all sections. Join the front and back sections together. Sew the sleeves together then weave in place. Sew the short ends of Collar together then sew 1 edge to the inside and 1 to the outside of neckline.

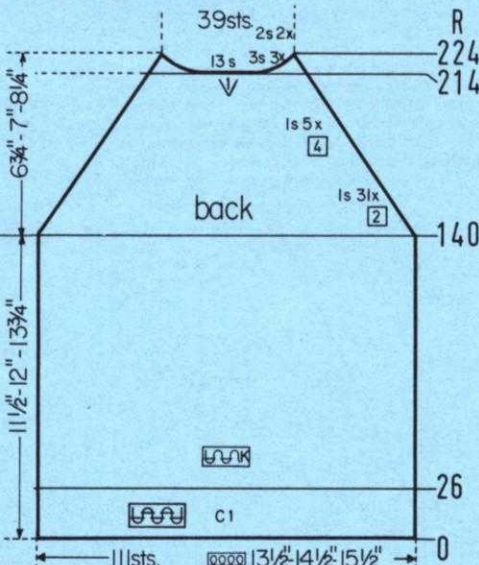

Bring the Cam Box to the left side, turn the Row Counter back to 214 and complete the left half. Follow the instructions from*.

*Continue to decrease for raglan shaping as before on EVEN rows and shape neck on ODD rows. ON CAM BOX SIDE, bind off 3 sts. after Row 215; 1 st. after Row 216; 3 sts. after Rows 217, 219; 1 st. after Row 220; 2 sts. after Rows 221, 223; 1 st. after Row 224.

ON EACH SIDE, decrease 1 st. every other row 31x, then on every 4th row ON EACH SIDE to Row 214. Bind off the center 13 sts., put the needles on the left side into holding position and complete the right half first.

ROWS 27 to 140: Knit even.

ROWS 0 to 26: Knit even, then change to Stockinette stitch.

Cast on 111 sts. with color 1 and work K1, P1 Ribbing.

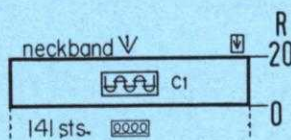

Cast on 141 sts. with color 1 and work 20 rows K1, P1 Ribbing, then bind off all sts. the crochet method for Ribbing.

Bring the Cam Box to the left side, turn the Row Counter back to 196 and complete the left half. Follow the instructions from*.

*Continue to decrease for raglan shaping as before on EVEN Rows and shape neck on ODD Rows. ON CAM BOX SIDE, decrease 1 st. after Row 196. Bind off 3 sts. after Row 197; 1 st. after Row 198; 3 sts. after Row 199; 1 st. after Row 200; 2 sts. after Row 201; 1 st. after Row 202; 2 sts. after Row 203; 1 st. after Rows 204, 205, 207; 1 st. after Rows 208, 211, 212, 215, 216. After Row 218, bind off the remaining sts.

Work the front section the same as the back section to Row 196. Bind off the center 9 sts., put the needles on the left side into holding position and complete the right half first.

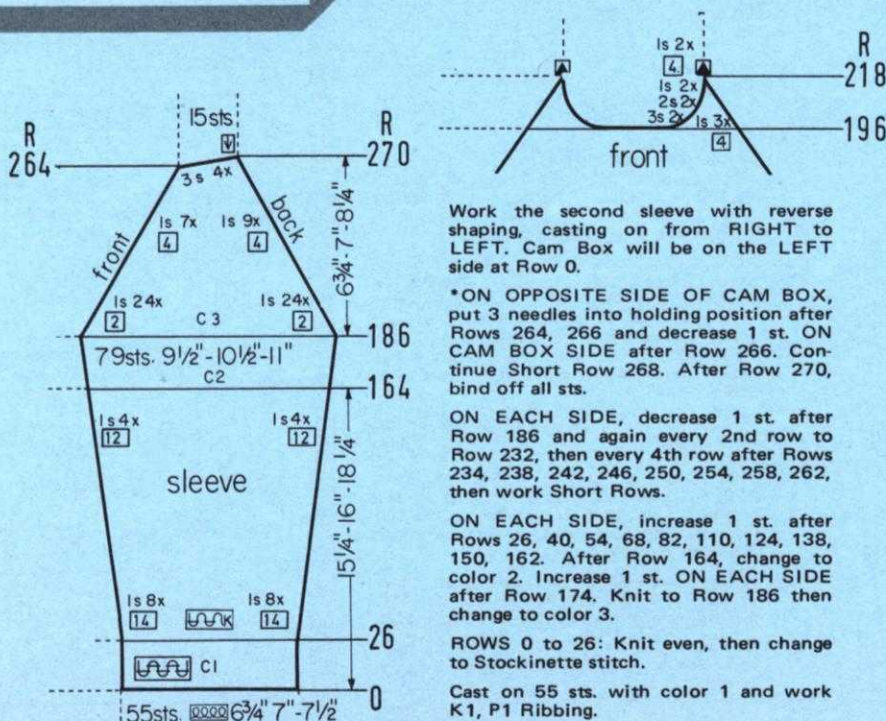

Work the second sleeve with reverse shaping, casting on from RIGHT to LEFT. Cam Box will be on the LEFT side at Row 0.

*ON OPPOSITE SIDE OF CAM BOX, put 3 needles into holding position after Rows 264, 266 and decrease 1 st. ON CAM BOX SIDE after Row 266. Continue Short Row 268. After Row 270, bind off all sts.

ON EACH SIDE, decrease 1 st. after Row 186 and again every 2nd row to Row 232, then every 4th row after Rows 234, 238, 242, 246, 250, 254, 258, 262, then work Short Rows.

ON EACH SIDE, increase 1 st. after Rows 26, 40, 54, 68, 82, 110, 124, 138, 150, 162. After Row 164, change to color 2. Increase 1 st. ON EACH SIDE after Row 174. Knit to Row 186 then change to color 3.

ROWS 0 to 26: Knit even, then change to Stockinette stitch.

Cast on 55 sts. with color 1 and work K1, P1 Ribbing.



HP 3727

SIZE:	36 (Chest 36"-37")	38 (Chest 38"-39")	40 (Chest 40"-41")
YARN:	Crocus Crepe	Allegro	Allegro
50 gr. BALLS:	5 C-1 4 C-2	5 C-1 4 C-2	5 C-1 4 C-2
TENSION:	5 to 7	5 to 7	6 to 8
GAUGE:	2" 10 sts. 21 rows	15 sts. 21 rows	14 sts. 20 rows
3 Buttons			

The instructions are the same for all sizes. PATTERN: Norwegian Design according to the Line Drawing or use JAC 40 and Pattern No. K550. In the instructions, each row in the Norwegian Design is counted as 1 row, but several movements of the Cam Box are needed to complete 1 row. Make all increases and decreases on the Edge. BANDS: Stockinette stitch with full fashion increases and decreases. INCREASES: Move the end st. 1 needle out then pick up the 2nd st. from the row below and hang it onto the empty needle. DECREASES: Hang the 2nd st. on the 1st needle and move the st. in to fill the empty needle.

FINISHING: Block all sections. Join back and fronts at shoulders. Bands are made by picking up stitches with the purl side facing you and hanging them onto the machine then knit 12 rows for each band and bind off the crochet method. For Armhole Band, pick up 140 sts. For the back of the neck, pick up 74 sts; for lower Front Band, pick the sts. up evenly from the side edge to the point; increase at point EVERY ROW 6x, and increase on side edge every other row 3x, then decrease in the same manner and bind off. For lower front band, from front edge to point, work the same as the other lower front band. For front bands from shoulder to bottom, pick up approximately 150 sts. Join ends of all bands together, fold in half and sew to the wrong side. Sew side seams. Finish buttonholes and sew on buttons.

Work the second front section with reverse shaping, casting on from RIGHT to LEFT. Cam Box will be on the LEFT side at Row 0 and MAKE BUTTON-HOLES over needles 3 to 8 counting from the RIGHT edge after Rows 50, 76, 102.

ON CAM BOX SIDE, bind off 5 sts. after Rows 230, 232, 234; 6 sts. after Rows 236, 238.

Start Armhole Shaping. ON CAM BOX SIDE, bind off 3 sts. after Row 138 (continue front neck shaping on ODD ROWS); 1 st. after Row 139; 3 sts. after Row 140; 1 st. after Row 141; 2 sts. after Row 142; 1 st. after Row 143; 2 sts. after Row 144; 1 st. after Rows 145, 146, 147, 148, 149, 150, 153, 157, 161, 165, 169, 173, 177, 181, 185, 189, 193, 197, 201, 205, 207, 211, 215, 221, 225, 229.

Start front Neck Shaping (ODD ROWS) and continue side increases (EVEN ROWS). Decrease 1 st. after Rows 109, 111; increase 1 st. after Row 112; decrease 1 st. after Rows 113, 115, 117; Increase 1 st. after Row 118; decrease 1 st. after Rows 119, 121, 123; increase 1 st. after Row 124; decrease 1 st. after Rows 125, 127, 129, 131, 133, 135, 137.

ON CAM BOX SIDE, increase 1 st. after Rows 50, 58, 64, 72, 80, 94, 100, 106.

Cast on 2 sts. after Row 2 (EVEN ROWS = SIDE SHAPING); 1 st. after Row 3 (ODD ROWS = FRONT SHAPING); 1 st. after Row 4; 2 sts. after Rows 5, 6, 7; 1 st. after Rows 8, 9; 2 sts. after Rows 10, 11; 1 st. after Row 12; 2 sts. after Rows 13, 14; 1 st. after Rows 15, 16; 2 sts. after Rows 17, 18, 19; 1 st. after Rows 20, 21; 2 sts. after Rows 22, 23; 1 st. after Row 24; 2 sts. after Rows 25, 26; 1 st. after Rows 27, 28; 2 sts. after Rows 29, 30, 31; 1 st. after Rows 32, 33; 2 sts. after Rows 34, 35; 1 st. after Row 36; 2 sts. after Row 37, then knit to Row 50.

Cast on 3 sts. with color 1 and work the Norwegian Design. (DO NOT MAKE Buttonholes in this section).

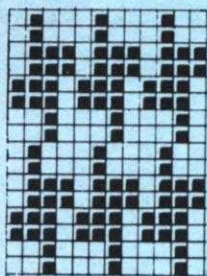
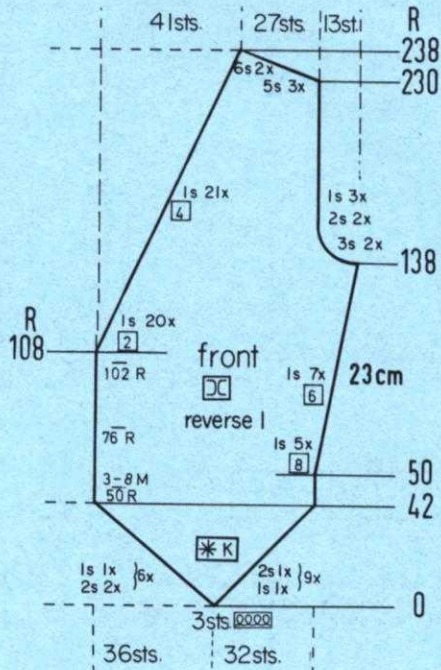

■ COLOR 2
□ COLOR 1

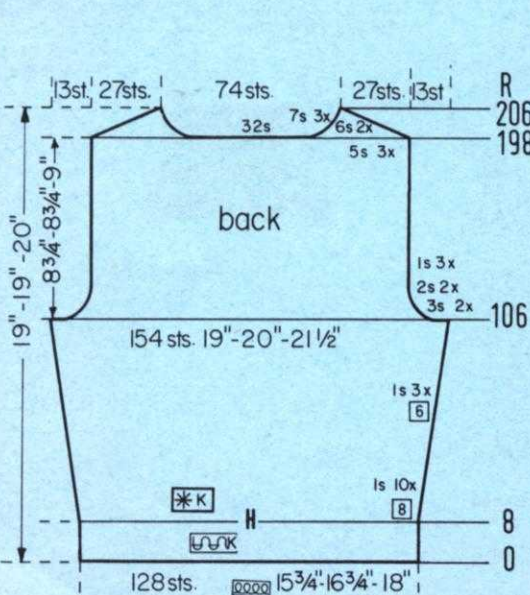

Bring the needles on the left side into working position, knit 1 row in Pattern to the left side, turn the Row Counter back to 198 and complete the left half. Follow the instructions from*.

*ON CAM BOX SIDE, bind off 5 sts. after Row 198 (EVEN ROWS = SHOULDER SHAPING); 7 sts. after Row 199 (ODD ROWS = NECK SHAPING); 5 sts. after Row 200; 7 sts. after Row 201; 5 sts. after Row 202; 7 sts. after Row 203; 6 sts. after Rows 204, 206.

ON CAM BOX SIDE, bind off 3 sts. after Rows 106, 107, 108, 109; 2 sts. after Rows 110, 111, 112, 113; 1 st. after Rows 114, 115, 116, 117, 118, 119, then knit to Row 198. Bind off the center 32 sts., put the needles on the left side into holding position and complete the right half first.

ON EACH SIDE, increase 1 st. after Rows 8, 16, 24, 32, 40, 48, 56, 64, 72, 80, 88, 94, 100, then knit to Row 106.

ROWS 0 to 8: Knit even, form the hem then change to the Norwegian Pattern Stitch.

Cast on 128 sts. with color 1 and work Stockinette stitch.

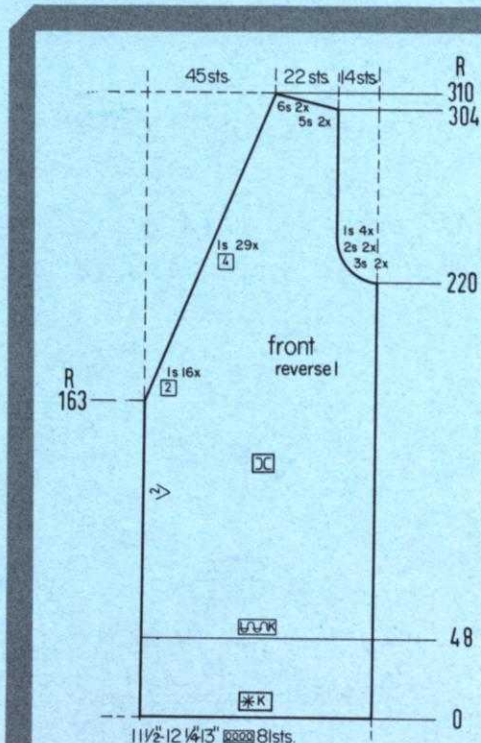

HP 3721

SIZE:	36 (Chest 36"-37")	38 (Chest 38"-39")	42 (Chest 42"-43")
YARN:	Flamingo	Allegro	Allegro
50 gr. BALLS:	18	18	19
TENSION:	6 to 8	7 to 9	8 to 10
GAUGE:	2" 14 sts. 19 rows	13 sts. 19 rows	12 sts. 17 rows

The instructions are the same for all sizes. PATTERN: Back and Front Stockinette stitch. Sleeves, Collar and Edges: 5 plus 1 Ribbing Pattern as in the Line Drawing. Belt: Stockinette stitch. DECREASES: Hang the 3rd st. onto the 2nd needle and move the end sts. inward to fill the empty needle. INCREASES: Move the end st. 1 needle outward, then pick up the 2nd st. from the row below and hang it onto the empty needle.

FINISHING: Block all sections. Join the fronts and back sections at sides and shoulders. Sew sleeves together and set in. Hem Sleeve and turn back cuff. Join center back Collar sections, then join collar ends to short ends of front bands. Sew 1 edge to inside and 1 edge to outside of neckline and front. Turn under half of the pattern sections for upper hem of pocket and sew in place. Sew pocket to fronts of Jacket. Seam long edge and ends of belt.

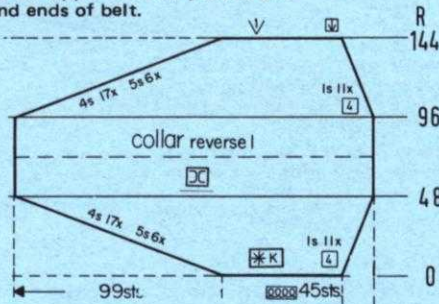

ON CAM BOX SIDE, bind off 1 st. after Row 96; 4 sts. after Rows 97, 99; 1 st. after Row 100; 4 sts. after Rows 101, 103; 1 st. after Row 104; 4 sts. after Rows 105, 107; 1 st. after Row 108; 4 sts. after Rows 109, 111; 1 st. after Row 112; 4 sts. after Rows 113, 115; 1 st. after Row 116; 4 sts. after Rows 117, 119; 1 st. after Row 120; 4 sts. after Rows 121, 123; 1 st. after Row 124; 4 sts. after Rows 125, 127; 1 st. after Row 128; 4 sts. after Row 129; 5 sts. after Row 131; 1 st. after Row 132; 5 sts. after Rows 133, 135; 1 st. after Row 136; 5 sts. after Rows 137, 141, 143. Bind off the remaining 45 sts. after Row 144.

ON CAM BOX SIDE, cast on 5 sts. after Rows 1, 3; 1 st. after Row 4; 5 sts. after Rows 5, 7; 1 st. after Row 8; 5 sts. after Rows 9, 11; 1 st. after Row 12; 4 sts. after Rows 13, 15; 1 st. after Row 16; 4 sts. after Rows 17, 19; 1 st. after Row 20; 4 sts. after Rows 21, 23; 1 st. after Row 24; 4 sts. after Rows 25, 27; 1 st. after Row 28; 4 sts. after Rows 29, 31; 1 st. after Row 32; 4 sts. after Rows 33, 35; 1 st. after Row 36; 4 sts. after Rows 37, 39; 1 st. after Row 40; 4 sts. after Rows 41, 43; 1 st. after Row 44; 4 sts. after Row 45, then knit to Row 96.

Cast on 45 sts. and work in Rib Pattern Stitch.

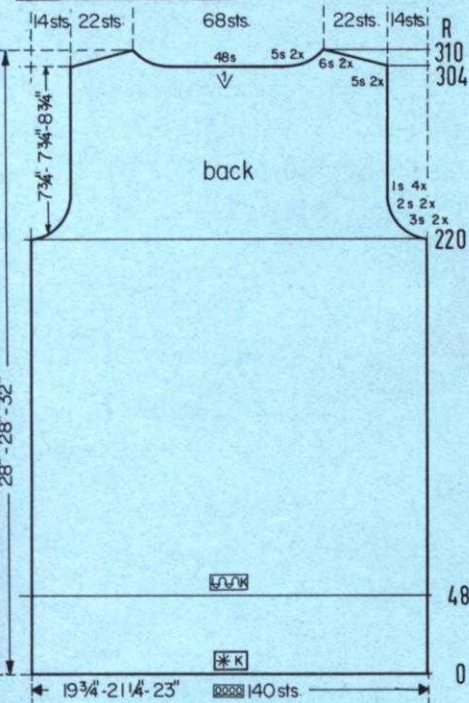

Move the Cam Box to the left side, turn the Row Counter back to 304 and complete the left half. Follow the instructions from*.

*ON CAM BOX SIDE, bind off 5 sts. after Row 304 (EVEN ROWS = SHOULDER SHAPING); 5 sts. after Row 305 (ODD ROWS = NECK SHAPING); 5 sts. after Rows 306, 307; 6 sts. after Rows 308, 310.

ON CAM BOX SIDE, bind off 3 sts. after Rows 220, 221, 222, 223; 2 sts. after Rows 224, 225, 226, 227; 1 st. after Rows 228, 229, 230, 231, 232, 233, 234, 235, then knit to Row 304, bind off the center 48 sts., put the needles on the left side into holding position and complete the right half first.

48 ROWS 49 to 220: Knit even.

ROWS 0 to 48: Knit even then change to Stockinette stitch.

0 Cast on 140 sts. and work in Rib Pattern Stitch.

HP 3721 FRONT

Work the second Front section with reverse shaping, casting on from Right to Left. Cam Box will be on the LEFT SIDE at Row 0.

ON CAM BOX SIDE, bind off 3 sts. after Row 220 (EVEN ROWS = ARM-HOLE SHAPING) and continue to decrease 1 st. on NECK EDGE on ODD ROWS. 3 sts. after Row 222; 1 st. after Row 223; 2 sts. after Rows 224, 226; 1 st. after Rows 227, 228, 230, 231, 232, 234, 235, 239, 243, 247, 251, 255, 259, 263, 267, 271, 275, 279, 283, 287, 291, 295, 299, 303; 5 sts. after Rows 304, 306 (Shoulder Shaping) 1 st. after Row 307 (last Neck decrease); 6 sts. after Rows 308, 310.

ON CAM BOX SIDE, decrease 1 st. after Row 163 (ODD ROWS = FRONT NECK SHAPING); 165, 167, 169, 171, 173, 175, 177, 179, 181, 183, 185, 187, 189, 191, 193, 195, 199, 203, 207, 211, 215, 219.

ROWS 49 to 163: Knit even.

ROWS 0 to 48: Knit even, then change to Stockinette stitch.

Cast on 81 sts. and work in Rib Pattern Stitch.

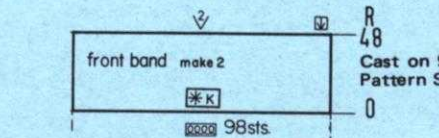

Cast on 98 sts. and work 48 Rows in Rib Pattern Stitch then bind off all sts.

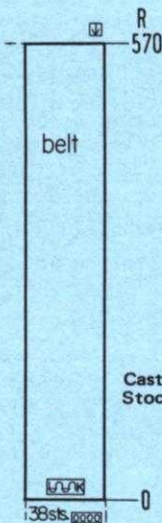

Cast on 38 sts. and work 570 rows Stockinette stitch then bind off all sts.

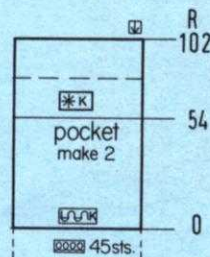

ROWS 55 to 102: Knit even then bind off all sts.

ROWS 0 to 54: Knit even, then change to Rib Pattern Stitch.

Cast on 45 sts. and work in Stockinette stitch.

ON CAM BOX SIDE, bind off 3 sts. after Rows 222, 223, 224, 225; 2 sts. after Rows 226, 227, 228, 229, 230, 231; 1 st. after Rows 232, 233, 234, 235, 236, 237; 2 sts. after Rows 238, 239; 1 st. after Rows 240, 241, 242, 243, 244, 245; 2 sts. after Rows 246, 247; 1 st. after Rows 248, 249, 250, 251, 252, 253; 2 sts. after Rows 254, 255; 1 st. after Rows 256, 257, 258, 259, 260, 261; 2 sts. after Rows 262, 263; 1 st. after Rows 264, 265, 266, 267, 268, 269; 3 sts. after Rows 270, 271; 4 sts. after Rows 272, 273, 274, 275; 14 sts. after Row 276.

ON EACH SIDE, increase 1 st. after Rows 58, 68, 78, 88, 98, 108, 118, 126, 134, 142, 150, 158, 166, 174, 182, 190, 198, 206, 214, then knit to Row 222.

ROWS 0 to 58: Knit even.

Cast on 68 sts. and work in Rib Pattern Stitch.

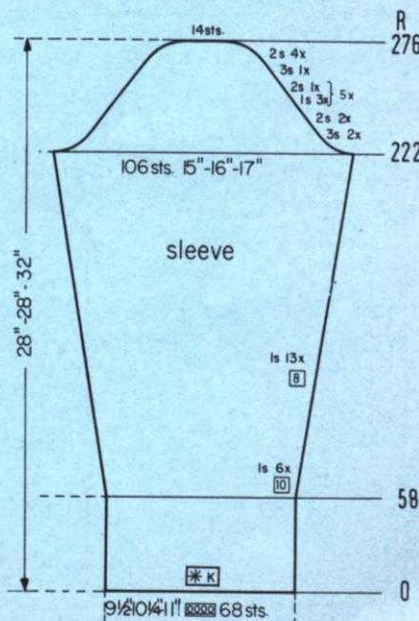

DK 8333

SIZE:	14 (Bust 35"-36")	16 (Bust 37"-38")	18 (Bust 39"-40")
YARN:	Beatrice	Beatrice	Beatrice
50 gr. BALLS:	18	19	20
TENSION:	3 to 5	4 to 6	5 to 7
GAUGE:	2" Stk. 17 sts. 23 rows Pattern 17 sts. 38 rows	16 sts. 22 rows 16 sts. 36 rows	15 sts. 21 rows 15 sts. 34 rows

The instructions are the same for all sizes: PATTERN: Holding Position Design that follows the Line Drawing or use JAC 40 and Pattern No. K505. DECREASES: Hang the 1st st. onto the 2nd st. INCREASES: Place the end st. from the row below onto the empty needle.

FINISHING: Block all sections. Join side and shoulder seams. Sew sleeve seams and set in. Fold under 32 rows on lower edge and hem. Fold under 36 rows on sleeves and hem. Fold over 11 sts. on the front edges and hem to the wrong side. Fold collar in half lengthwise and sew the short ends then sew 1 edge to the inside and 1 edge to the outside of neckline.



Work the second front section with reverse shaping, casting on from RIGHT to LEFT. Cam Box will be on the LEFT SIDE at Row 0.

Hang the 11 sts. held on the stitch holder back onto the machine. With Cam Box on the left side, Row Counter at 259 (watch Pattern), decrease 1 st. OPPOSITE CAM BOX after Rows 261, 263, 265, 267, 269, 271, 273, 275, 277, 279, 281.

SHAPE SHOULDER ON CAM BOX SIDE by binding off 3 sts. after Rows 518, 520, 522, 524, 526, 528, 530, 532, 534, 536, 538; 4 sts. after Row 540.

Continue to SHAPE NECK on ODD ROWS and SHAPE ARMHOLE ON EVEN ROWS. Bind off 4 sts. after Row 360; 1 st. after Row 361; 4 sts. after Row 364; 1 st. after Row 367; 3 sts. after Rows 368, 372; 1 st. after Row 373; 3 sts. after Row 376; 1 st. after Row 379; 2 sts. after Rows 380, 384; 1 st. after Row 385; 2 sts. after Row 388; 1 st. after Rows 391, 392, 396, 397, 400, 403, 409, 415, 421, 427, 433, 439, 445, 451, 457, 463, 469, 475, 481, 487, 489, 499, 505. Knit to Row 518.

Continue to decrease 1 st. on SIDE EDGE on EVEN ROWS and ON ODD ROWS decrease 1 st. for NECK after Rows 261, 263, 265, 267, 269, 271, 273, 274, 275, 277, 279, 281, 283, 285, 287, 289, 293, 297, 301, 305, 309, 313, 314, 317, 321, 325, 329, 333, 337, 343, 349, 355.

ON CAM BOX SIDE, decrease 1 st. after Rows 64, 106, 148, 190, 232. After Row 259, remove 11 sts. on the LEFT (right for second section) onto a stitch holder (make note of Pattern Row). Attach another ball of yarn and continue over the 120 sts.

ROWS 30 to 64: Knit even.

ROWS 0 to 29: Knit even, then cast on 24 sts. for the band.

Cast on 112 sts. and work in Pattern.

ON EACH SIDE, decrease 1 st. after Rows 363, 366, 369, 372, 375, 378, 381, 384, 387, 390, 393, 396, 399, 402, 405, 408, 411, 414, 417, 420. ON CAM BOX SIDE, bind off 2 sts. after Rows 424, 425; 4 sts. after Rows 428, 429, 432, 433; 20 sts. after Row 434.

ON CAM BOX SIDE, bind off 5 sts. after Rows 340, 341, 344, 345; 4 sts. after Rows 348, 349, 352, 353, 356, 357; 2 sts. after Rows 360, 361.

ROWS 0 to 340: Knit even.

Cast on 128 sts. and work in Pattern.

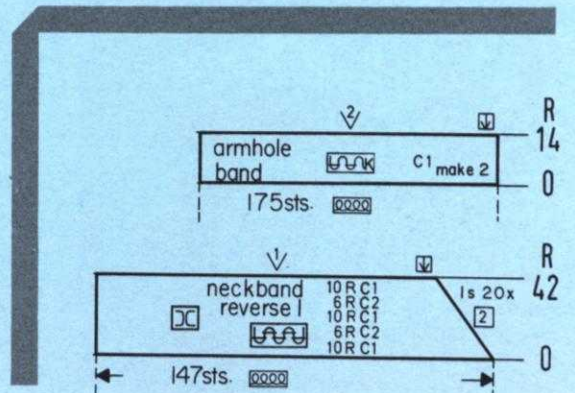
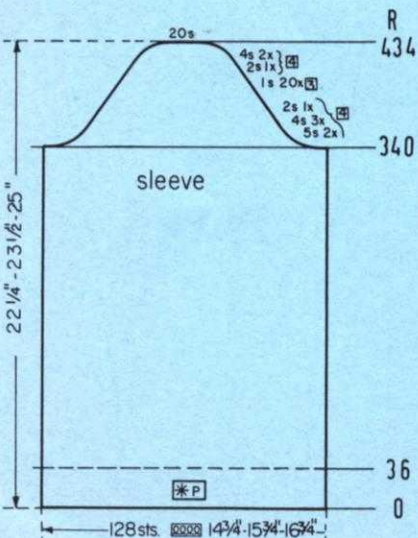
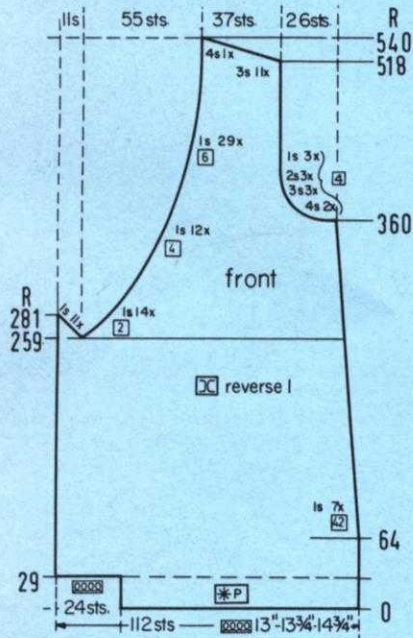
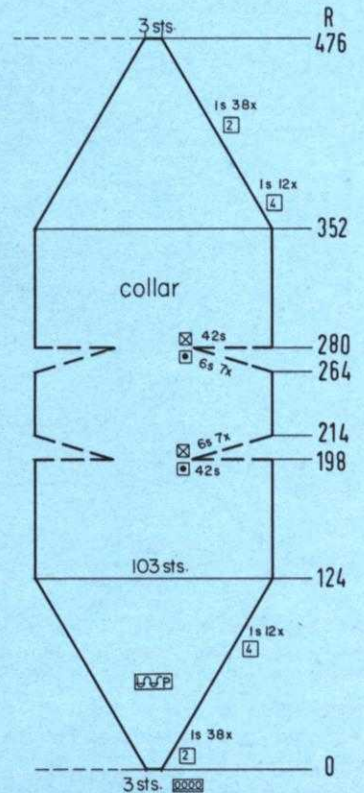
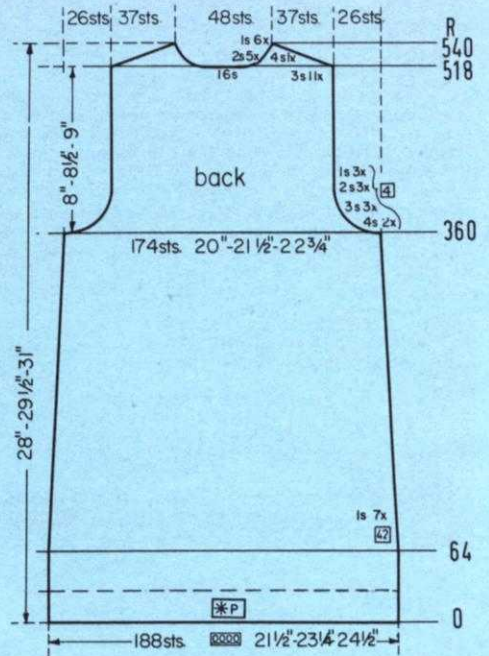

Bring the needles on the left side into working position. Knit 1 row in Pattern to the left, turn the Row Counter back to 518 and complete the left half. Follow the instructions from*.

*ON CAM BOX SIDE, bind off 3 sts. after Row 518 (EVEN ROWS = SHOULDER SHAPING); 2 sts. after Row 519 (ODD ROWS = NECK SHAPING); 3 sts. after Row 520; 2 sts. after Row 521; 3 sts. after Row 522; 2 sts. after Row 523; 3 sts. after Row 524; 2 sts. after Row 525; 3 sts. after Row 526; 2 sts. after Row 527; 3 sts. after Row 528; 1 st. after Row 529; 3 sts. after Row 530; 1 st. after Row 531; 3 sts. after Row 532; 1 st. after Row 533; 3 sts. after Row 534; 1 st. after Row 535; 3 sts. after Row 536; 1 st. after Row 537; 3 sts. after Row 538; 1 st. after Row 539; 4 sts. after Row 540.

ON CAM BOX SIDE, bind off 4 sts. after Rows 360, 361, 364, 365; 3 sts. after Rows 368, 369, 372, 373, 376, 377; 2 sts. after Rows 380, 381, 384, 385, 388, 389; 1 st. after Rows 392, 393, 396, 397, 400, 401, then knit to Row 518, bind off the Center 16 sts., put the needles on the left side into holding position and complete the right half first.

ON EACH SIDE, decrease 1 st. after Rows 64, 106, 148, 232, 274, 316, then knit to Row 360.

ROWS 0 to 64: Knit even.

Cast on 188 sts. and work in Holding Position Design.

ON EACH SIDE, decrease 1 st. after Row 352 and every 4th row 11x more then every 2nd row 38x. After Row 476, bind off the remaining 3 sts.

ON OPPOSITE SIDE OF CAM BOX, put into holding position, 6 needles after Rows 264, 265, 266, 267, 268, 269, 270, 271, 272, 273, 274, 275, 276, 277. ON OPPOSITE SIDE OF CAM BOX, bring all the needles back into working position after Rows 278, 279. Knit even to Row 352.

ON OPPOSITE SIDE OF CAM BOX, put into holding position, 42 needles after Rows 198, 199. ON OPPOSITE SIDE OF CAM BOX, bring back into working position, 6 needles after Rows 200, 201, 202, 203, 204, 205, 206, 207, 208, 209, 210, 211, 212, 213. Knit to Row 264 then work Short Rows.

ON EACH SIDE, increase 1 st. every other Row 38x, then every 4th Row 12x. Knit even to Row 198 then work Short Rows.

Cast on 3 sts. and work Stockinette stitch.

Make 2. Cast on 175 sts. with color 1 and work 14 rows Stockinette stitch then bind off all sts.

ROWS 0 to 42: ON CAM BOX SIDE, decrease 1 st. after Row 2 and again every other row 19x more, then bind off all sts. Make second band with reverse shaping, casting on from Right to Left. Cam Box will be on the LEFT side at Row 0.

Cast on 147 sts. with color 1 and work K1, P1 Ribbing with color stripes as marked on the Chart.

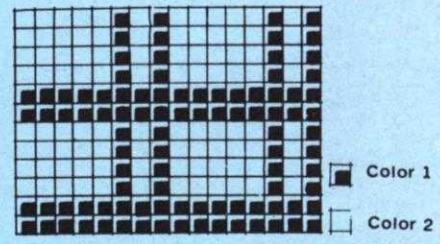
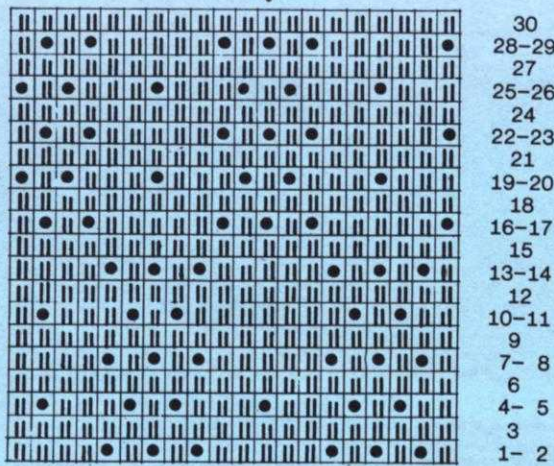

DK 8334

SIZE:	14 (Bust 35"-36")	16 (Bust 37"-38")	18 (Bust 39"-40")
YARN:	Beatrice	Beatrice	Beatrice
50 gr. BALLS:	4 color 1 4 color 2	4 color 1 4 color 2	5 color 1 5 color 2
TENSION:	3 to 5	4 to 6	5 to 7
GAUGE:	2" 17 sts. 23 rows	16 sts. 22 rows	15 sts. 21 rows

The instructions are the same for all sizes. PATTERN: Norwegian Design that follows the Line Drawing. In the instructions, each row of the Norwegian Design is counted as 1 row but several movements of the Cam Box are needed to complete 1 row. DECREASES: Hang the 1st st. onto the 2nd st. INCREASES: Place the end st. from the row below onto the empty needle. NECK and Lower BANDS: K1, P1 Ribbing. Armbands: Stockinette stitch. When decreasing for the Neckband sections, use the full fashion method and hang the 2nd st. onto the 3rd st. then move the end st. in to fill the empty needle. You can knit the bands using a MOCK Rib if you like by doubling the number of rows but be sure to turn the Row Counter back to the correct number so that you are able to follow the instructions as given.

FINISHING: Block all sections. Sew side and shoulder seams. Sew short ends of armbands together, then sew 1 edge to the inside and 1 to the outside of armholes. Sew the straight edges of neckband sections together, then sew 1 edge to the neckline with the right edge of front crossing the left edge of band (see Picture).

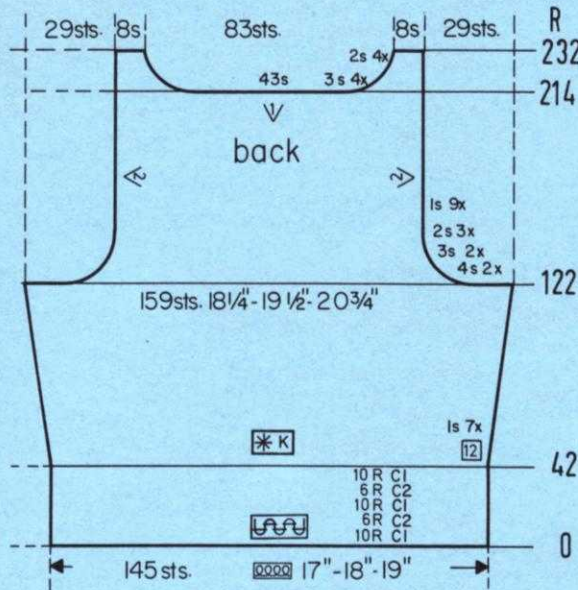

Bring the needles on the left into working position, knit 1 row in Pattern to the left side, turn the Row Counter back to 214 and complete the left half. Follow the instructions from*.

*ON CAM BOX SIDE, bind off 3 sts. after Rows 215, 217, 219; 2 sts. after Rows 221, 223, 225, 227. Knit to Row 232 and bind off the remaining 8 sts.

ON CAM BOX SIDE, bind off 4 sts. after Rows 122, 123, 124, 125; 3 sts. after Rows 126, 127, 128, 129; 2 sts. after Rows 130, 131, 132, 133, 134, 135; ON EACH SIDE, decrease 1 st. after Rows 136, 138, 140, 142, 144, 146, 148, 150, 152. Knit to Row 214, bind off the center 43 sts., put the needles on the left side into holding position and complete the right half first.

ON EACH SIDE, increase 1 st. after Rows 42, 54, 66, 78, 90, 102, 114. Knit to Row 122.

ROWS 0 to 42: Knit even, then change to the Norwegian Design.

Cast on 145 sts. with color 1 and work K1, P1 Ribbing with color stripes as marked on the Chart.

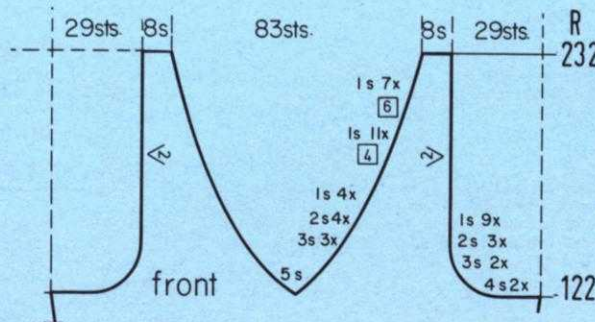

*ON CAM BOX SIDE, bind off 4 sts. after Row 122 (EVEN ROWS = ARM-HOLE SHAPING); 3 sts. after Row 123 (ODD ROWS = NECK SHAPING); 4 sts. after Row 124; 3 sts. after Rows 125, 126, 127, 128; 2 sts. after Rows 129, 130, 131, 132, 133, 134, 135; 1 st. after Rows 136, 137, 138, 139, 140, 141, 142, 143, 144, 146, 147, 148, 150, 151, 152, 159, 163, 167, 171, 175, 179, 183, 187, 191, 197, 203, 209, 215, 221, 227. After Row 232, bind off the remaining 8 sts.

Work the front section the same as the back section to Row 122. Bind off the center 5 sts., put the needles on the left side into holding position and complete the right half first.

KK5529

SIZE:	6 (Chest 24"-25")	8 (Chest 27"-28")	10 (Chest 29"-30")
YARN:	Flamingo	Flamingo	Sport Prima
50 gr. BALLS:	3 C-1 2 C-2	3 C-1 2 C-2	4 C-1 3 C-2
TENSION:	7 to 9	8 to 10	9 to 10
GAUGE:	2" 14 sts. 19 rows	13 sts. 18 rows	12 sts. 17 rows

The instructions are the same for all sizes. PATTERN: Version A: Norwegian Design according to the Line Drawing, or use JAC 40 and Pattern No. K621. In the instructions, each row in the Norwegian Design is counted as 1 row, but several movements of the Cam Box are needed to complete 1 row. Version B: Use the Adjustable Needle Selector and follow the Line Drawing using the Norwegian technique.

FINISHING: Block the sections. Join front and back sections at sides and shoulders. Join the short ends of the armhole bands and neckband and sew 1 edge to the inside and 1 edge to the outside.



Bring the needles on the left side into working position, knit 1 row in Pattern to the left side, turn the Row Counter back to 144 and complete the left half. Follow the instructions from*.

*ON CAM BOX SIDE, bind off 3 sts. after Rows 145, 147; 2 sts. after Rows 149, 151, 153. After Row 160, bind off the 6 shoulder sts.

ON CAM BOX SIDE, bind off 3 sts. after Rows 96, 97, 98, 99; 2 sts. after Rows 100, 101, 102, 103, 104, 105. ON EACH SIDE, decrease 1 st. after Rows 106, 108, 110, 112, 114, 116, 118, then knit to Row 144, bind off the center 18 sts., put the needles on the left side into holding position and complete the right half first.

ROWS 19 to 96: Knit even.

ROWS 11 to 18: Knit even, then hang the hem by placing each cast on stitch onto the needles behind the latches. Change to the Norwegian Design.

ROWS 0 to 8: Knit even, then transfer every 2nd stitch to the adjacent needle for picot edge and leave the empty needles in working position. Knit 2 rows to complete the picot.

Cast on 92 sts. with color 1 and work Stockinette stitch.

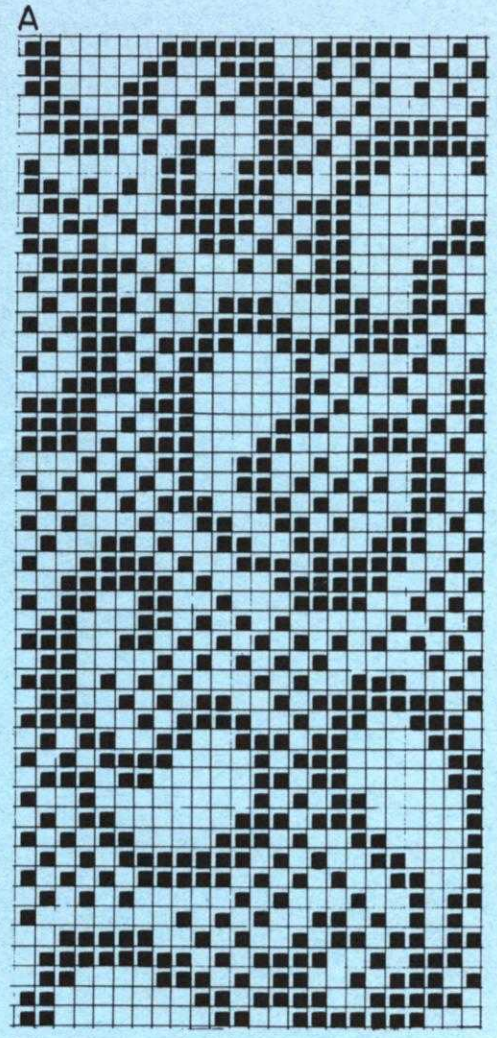

□ - COLOR 1 ■ - COLOR 2

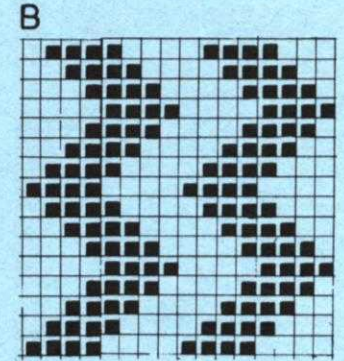

□ - COLOR 1 ■ - COLOR 2

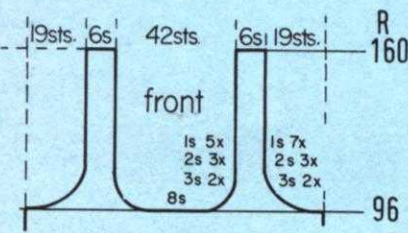
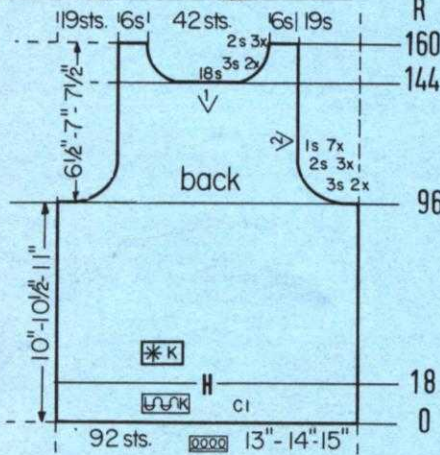

Bring the needles on the left side into working position, knit 1 row in Pattern to the left, turn the Row Counter back to 96 and complete the left half. Follow the instructions from*.

*ON CAM BOX SIDE, bind off 3 sts. after Row 96 (EVEN ROWS = ARMHOLE SHAPING), 97 (ODD ROWS = NECK SHAPING), 98, 99; 2 sts. after Rows 100, 101, 102, 103, 104, 105; 1 st. after Rows 106, 107, 108, 109, 110, 112, 113, 114, 115, 116, 118. After Row 160, bind off the remaining 6 sts. for shoulder.

Work the front section the same as the back section to Row 96, then bind off the center 8 sts., put the needles on the left side into holding position and complete the right half.

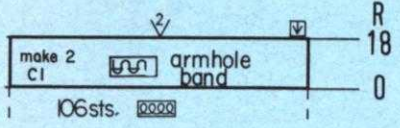

Cast on 106 sts. with color 1 and work the same as the Neckband.

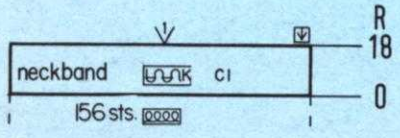

Cast on 156 sts. with color 1 and knit 8 rows. Transfer every 2nd st. to next needle and leave empty needles in working position. Knit to Row 18, then bind off loosely.

BE SURE TO NOTIFY US IMMEDIATELY OF ANY CHANGE OF ADDRESS. THE POST OFFICE WILL NOT FORWARD YOUR MAGAZINE TO YOU.

KG 1984 — Three Pattern Bonus . . . Lively colors and contrasts brighten a room for your teen age son or daughter. The Blanket is knitted in strips then woven together. One Cushion is knitted using Short Rows . . . the other is a knitted cord sewn to a backing. You can use scraps of yarn (same weight please) or order Flamingo from us.





KK 5418 – Two for one! For a boy or a girl . . . a warm Pullover is knitted in Stockinette stitch then topped with a Norwegian Design Vest in 4 colors. The bands are a 1 x 1 Rib. Size 4 and 6 are made with Beatrice; Size 8 with Crocus.

FOR
MOTHER
AND
CHILD

DK 8172 – Knit yourself a lovely feminine Suit using the same Norwegian Design as your child's for the border on the Jacket and Sleeves. If you own a JAC 40, choose a similar design from your patterns instead of following the Line Drawing. Sizes: 10, 12 and 16.



KK 5529 — The classroom crowd goes back to school. Youngsters love the layered look and these Pullover Vests are perfect over a blouse. The same instructions are used for View A and B . . . just use a different Norwegian Design as shown. Size 6 and 8 are made with Flamingo Dralon; Size 12 with Sport Prima.



HP 3727 — High fashion for men is a flashy Vest knitted in a Norwegian Design. The bands are in Stockinette stitch. Use two colors of Crocus Crepe for Size 36; Allegro for Sizes 38 and 40.



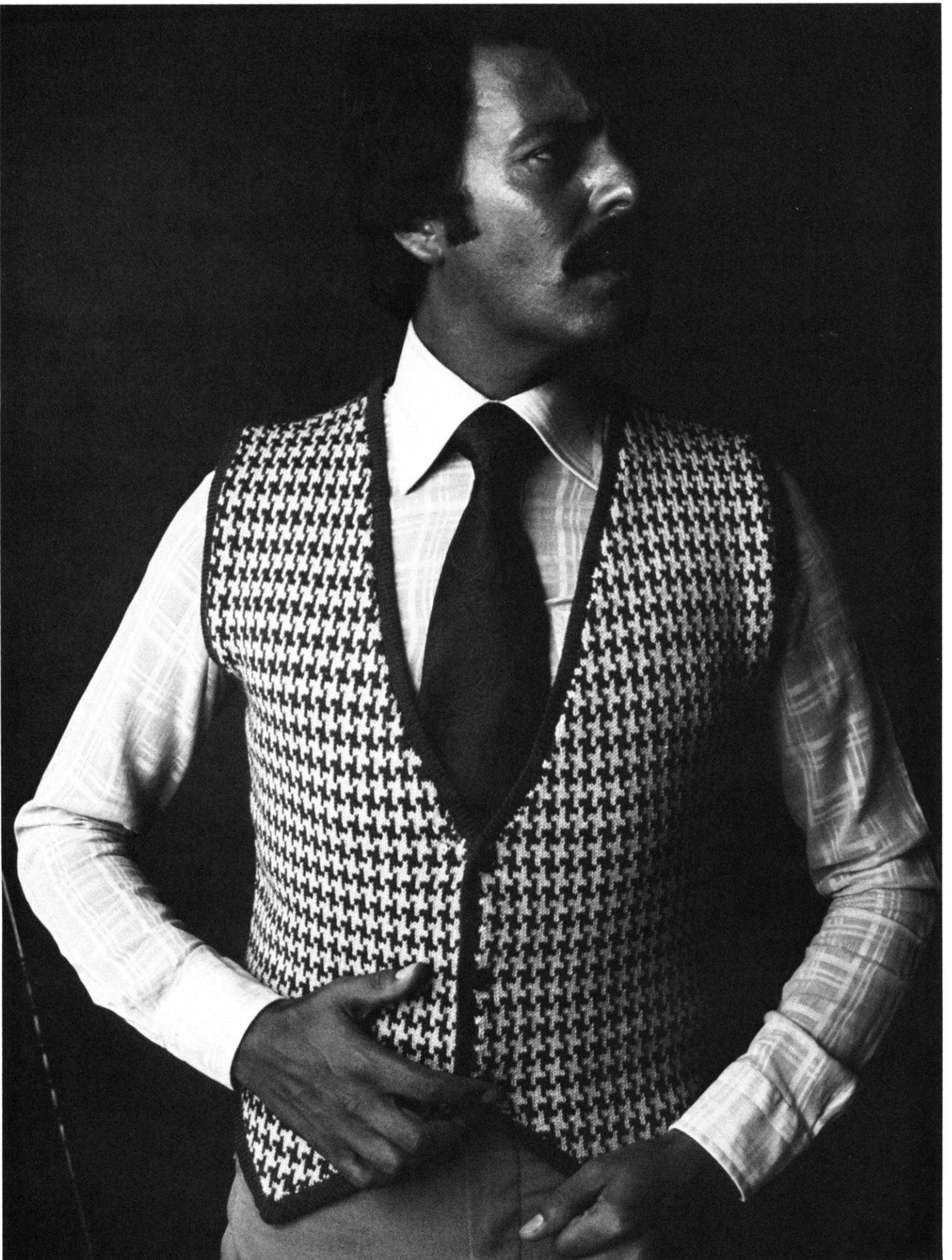



DK 8333 and DK 8334 — A shawl collared Jacket is knitted in a Holding Position Design . . . Wear it over the bright Pullover knitted in a Norwegian Design. Use a Mock Rib for the bands as shown in picture or use the 1 x 1 Rib if you have a Ribber. Both Jacket and Pullover are knitted with Beatrice in Sizes 14, 16 and 18.

HP 3721 — Knit your sportsman a warm Jacket. The Sleeves, bands and edge of pocket are knitted in a widely spaced rib with fronts and back in Stockinette stitch. Use Flamingo Dralon for Size 36; Allegro for Sizes 38 and 42.





MK 5503 — Wide color stripes on the sleeves of a girl's raglan Pullover make a nice addition to a back to school wardrobe. It's quickly knitted in Stockinette stitch with a 1 x 1 Rib for the bands. Knit Size 6 with Regia; Sizes 8 and 10 with Allegro.



Knitking News

OUR READERS WRITE

Some subscribers write to tell us they have problems when putting their garments together - they end up with one edge shorter than the other... or a neckband or armhole band looks lopsided... Well, there is a solution easy as can be... but you must REMEMBER to follow a simple procedure for marking your garments as you knit, then we can promise your troubles will disappear.... SO.....

MARK.... MARK... MARK....

Tie a small piece of contrast waste yarn on each end needle after knitting approximately 100 rows all along a section of garment. Remember this means you should mark the front and back sections of a pullover, dress, jacket, sleeve, every section of a skirt or pants. If you are knitting extra rows in place of knitting a bust dart, then you should mark where the extra rows begin and again where they end, so that you know these are the rows to be eased into the back section at the bust level. ALWAYS MARK the center of each neck section, the center of a collar, the center of a neckband or armband. Don't make a hard knot, just tie it once so that it will be easy to pull out later.

When you have all the sections of your garment knitted and blocked, it is very easy to pin the sections together matching the markers of yarn along the side edges. The center mark on the neckband will match the center front or back at neckline - or it could go on the shoulder seam if the neckband is made in one section and you want the seam of the band at the shoulder. Sew or weave your seams together making sure the markers meet exactly and if they do not, then you only need to pull out a few rows to go back and make those rows match up nicely. Match the armband seam at the underarm and the center marking on band at the shoulder seam or if you are round shouldered, put the center marking of the band slightly toward the back of shoulder seam to allow a little extra room over the shoulder (the band won't pull up then). Pin the center of a collar to the center back neck then pin the front edges in place and distribute the rest of the collar evenly around the neckline. ALWAYS pin first, then sew in place. If you will remember to mark as you knit, you will always have garments that are easy to put together and are professional in appearance.

PRACTICAL KNITTING HINTS

USING OUT OF WORK POSITION FOR HOLDING STITCHES

If you are knitting a Pattern Stitch and want to work on one side at a time, when you reach the neck and shoulder shaping, you cannot put the needles of the left side into the normal holding position because when using the Retractor Buttons and Push Button controls of the KNITKING machine or the Push Buttons and Cam Levers of a Japanese machine for your design, the needles in the normal holding position will operate when you do not wish them to. Some knitters take the left side stitches off onto contrast waste yarn and after completing the right half, hang the left side stitches back onto the machine. This is terribly time consuming and it is so easy to make a mistake.... but there IS another method that works beautifully for all machines and this is the way it goes....

When your Pattern says to bind off the center neck stitches, the first thing to do is write down the Pattern Row Number. Now take a Ravel Cord and knit each of the center neck stitches by hand, pulling each stitch all the way back against the back rail of your machine (out of work position) with the stitch held in the HOOK of the needle. Continue using the Ravel Cord to knit across all of the remaining stitches on the left half of the garment.

Now you can go ahead and work the right half of the neck and the right shoulder shaping. If you own a Japanese machine, you should place a strip of Scotch Tape across the knitting being held on the Ravel Cord.... Place the strip lightly across the knitting on the left side only right underneath the sinker pegs because if you do not do this, the fabric brushes on the Slide will rub against the knitting as you work on the right side and make unsightly fuzz. Do not press hard on the tape, it will hold if you gently put it on and then when you need to remove it, it will come away easily without spoiling your knitting.

After you have completed the right half, begin on the left side and pull the Ravel Cord toward you gently, unravelling the cord so that the last row of knitting returns to the needles. Be careful to stop at the left edge of the center neck stitches. KNITKING machine owners, put the stitches behind the latches and under the sinkers, the needles in working position, knit 1 row in Pattern (check your Pattern Row Number) to the left side, turn the Row Counter back to the proper row and continue in pattern as you shape the left half. Japanese machine owners, leave the stitches in the HOOKS of the needles, remove the Scotch Tape, knit 1 row in Pattern (check Pattern Row Number) to the left side, turn the Row Counter back to the correct number and complete the left half.

When shaping the neck and shoulders you can bind off the neck and shoulder stitches or you can use the Short Row Method to be bound off when the shaping is completed... A beginner in machine knitting will find it easier to bind off the stitches as she shapes a garment, but an experienced knitter will usually prefer to use the Short Row method for neck and shoulder shapings. In either case, you will find the above method for holding stitches of the left half while you knit the right half....absolutely great!!!

MARKING BUTTON BANDS

When knitting the front sections of a sweater, jacket or dress that has buttonholes - or separate buttonhole bands, you are given the rows on which to make the buttonholes... so... when knitting the button side, or button bands, use the same row numbers used for making buttonholes and tie in a piece of contrast yarn at each buttonhole row, then when you finish the buttonholes, the mark of contrast yarn on the button band shows you exactly where to sew on the buttons.

SPECIAL ON WHIZ KING PATTERNS THIS ISSUE

There are 5 new sets of Pattern Reader Charts available in this issue. Remember that when you buy KNITKING YARNS, you get the Charts FREE as well as a discount on the yarns for each of the garments. In order to take advantage of the special savings, you must place your order before the end of October....

If you like, you can buy the Charts without using our Yarns. DK 8343 and DK 8353 Chart Sets cost \$3.00 each set plus 50¢ Shipping. MK 5503 and DK 8333 are \$2.00 each set plus 50¢ Shipping. KK 5529 is \$1.00 per set and 50¢ Shipping.

The prices of all Kits including Yarns and Charts are:

MK 5503 - Yarn - Allegro

SIZES:	4	6	8
50gr. balls	5-C1	5-C1	6-C1
	1-C2	1-C2	1-C2
	1-C3	1-C3	1-C3
Regular Price	\$6.45	\$6.45	\$7.74
	1.29	1.29	1.29
	1.29	1.29	1.29
Total	\$9.03	\$9.03	\$10.32
SALE PRICE:	\$5.15	\$5.15	\$6.18
	1.03	1.03	1.03
	1.03	1.03	1.03
TOTAL	\$7.21	\$7.21	\$8.24

DK 8333 - Yarn - Beatrice Crepe

SIZES:	8/10	12/14	16/18
50 gr. balls	18	19	20
Regular Price	\$34.02	\$35.91	\$37.80
SALE PRICE:	\$27.00	\$28.50	\$30.00

DK 8343 - Yarn - Subita Crepe and Melodie

SIZES:	8/10	12/14	16/18
50gr. balls -Dress	13-C1	14-C1	15-C1
Jacket	4-C1	5-C1	5-C1
	3-C2	3-C2	3-C2
Regular Price	\$21.97	\$23.66	\$25.35
	6.76	8.45	8.45
	4.77	4.77	4.77
Total	\$33.50	\$36.88	\$38.57
SALE PRICE:	17.55	18.90	20.25
	5.50	6.85	6.85
	3.81	3.81	3.81
TOTAL	\$26.86	\$29.56	\$30.91

DK 8353 - Yarn - Sport Prima

SIZES:	12	14	18
50gr. balls	18	20	22
Regular Price	\$28.62	\$31.80	\$34.98
SALE PRICE:	\$22.86	\$25.40	\$27.94

KK 5529 - Yarn - Flamingo Dralon

SIZES:	5/6	7/8	9/10
50gr. balls	3-C1	3-C1	4-C1
	2-C2	2-C2	3-C2
Regular Price	\$5.45	\$5.45	\$7.63
SALE PRICE:	\$4.35	\$4.35	\$6.09

Shipping costs for Kits DK 8333 and DK 8353 are \$1.50 each Kit; for MK 5503 and DK 5529, \$1.00 each Kit; for DK 8343 \$1.50 for Size 8/10 and \$1.90 for Sizes 12/14 and 16/18. (California residents, please add Sales Tax on merchandise only).

JAC 40 PUNCH CARDS

We have a couple of apologies to make this issue.. the first is regarding delays in getting JAC 40 Punch Cards to you. We are sure you are aware of the world shortage of plastic materials... well it temporarily cut off the supply of plastic sheets used in the making of JAC 40 Cards... Many of your orders for new design cards were delayed and some are still outstanding. Please be patient with us... supplies are gradually building up again and we will ship out back orders as we receive supplies from our European factory.

FREE THREAD CUTTERS

Our second apology is regarding the Thread Cutters we are giving away to subscribers sending in renewals for the new increased size KNITKING MAGAZINE... Our substantial supply of cutters ran out within 3 weeks of the offer... We had already placed an order for a further quantity and.... would you believe it..? there is a shortage of steel in Japan... If you have sent in a \$10.00 renewal and not received your cutters, please bear with us... they are on their way... we will send them out within a few days of their receipt by us.

THANK YOU FOR TIGER

We want to thank all the wonderful people who took the time to talk to us, to write or to telephone offering their condolences on the loss of our dear Tiger.... Your sympathy is truly appreciated.... Thank you.

KATY SAYS...



WATCH OUT FOR THE NEXT ISSUE....!!

NOTES TO KNIT BY . . .

STITCH AND ROW GAUGE

KNIT A SAMPLE SWATCH . . . before you begin to knit any garment . . . for this is the MOST IMPORTANT STEP toward the correct size and the proper fit of any garment you wish to make. You MUST use the SAME YARN for your sample swatch that you will use to knit your garment and your sample swatch must be knitted large enough and using several different tension numbers on your machine. When you have done this, then you can determine the number of stitches and the number of rows in a two-inch measure. KNITTING MAGAZINE PATTERNS give you 3 tensions to try and one of them should give you the correct stitch and row gauge if you are using the yarn we recommend or a similar weight yarn. Here is the way to make your sample swatch.

Cast on over a sufficient number of needles to produce a swatch at least 4 inches wide. (If the pattern calls for 16 stitches to 2", then 16 x 2 = 32 stitches to cast on). Now knit 4 inches of rows at the first suggested tension number. (If the pattern calls for 22 rows to 2", 22 x 2 = 44 rows to knit). Knit 2 rows using a contrast color, change to the next higher tension and with garment yarn knit another 4", knit 2 rows with contrast color, change to the 3rd higher tension and knit another 4" and then bind off.



Roll the swatch into a cylinder over its length and pull on both ends, unroll it and stretch it diagonally by pulling on the four corners. Allow the swatch to rest and settle (preferably overnight) and then using a stitch gauge or a ruler, count the number of stitches over a 2" width, then the number of rows over a 2" length in EACH of the 3 tensions. Select the tension number that produces the stitches and rows called for in the pattern. If none of them are correct, you are most likely using the wrong weight of yarn.



READING OF CHARTS

You will notice the instructions start at the bottom of the Chart and work UP. Follow the charts exactly as written and providing your sample stitch and row gauge is correct, your garment will come out the right size. Please remember that the section of garment as it is knitted on the machine, faces the same way as the Charts are in this magazine. Where two front pieces are needed, (or any other part of a garment that needs two sections) only one section is normally shown and the second section is usually made with reverse shaping. Set in sleeves are usually identical, but raglan sleeves have to be knitted with reverse shaping for the second sleeve.

READING OF SYMBOLS

To simplify Pattern Knitting, we use Symbols in the Line Drawings and the Chart Diagrams. In the Line Drawings the symbols are shown and are to be read as you look at them while knitting a garment. For instance, if

a Purl stitch faces you, the Purl stitch Symbol  is shown; if a knit stitch faces you (as when using the Ribber) then this Symbol  is shown. The Symbol  at the top of the Line Drawing is the center of the garment section and you use this as a guide for setting up the needles.

The following Symbols    are used for Eyelet Designs in the Line Drawings and also for Full Fashion shaping on the Charts. The Line Drawings have row numbers on the right side. Missing Row numbers are always knitted straight or plain.

In Holding Position Designs  selected needles are pushed into holding position for the stated number of rows. The numbers of rows appear at the right of the Line Drawings; Example: 1-4 means knit Rows 1 to 4; 5 to 7 means knit Rows 5 to 7, etc. This same Symbol is also shown on the Charts and is used for putting needles into holding position for Short Rows. The

Symbol  on the Charts is used to put needles back into working position when knitting Short Rows.

A number in a box stands for the number of rows to be knitted between shapings. Make shaping first, then knit the necessary number of rows. If for instance it reads:

1 st. 8 x



1 st. 10 x



As you will be reading the instructions from the bottom up, here is the way you will follow them: . . . Decrease or increase (depending on the direction of the garment outline) 1 st. at the row where the shaping begins, then knit 8 rows, make the next decrease, then knit 8 rows, until you have decreased (or increased) 1 st. 10 x and you have knitted 8 rows after each decrease (or increase) (1 st. 10 x + 8 rows 10 x). Now begin the first decrease (or increase) for the shaping (which has to be made 8 x) in every 6th row. Decrease (or increase) 1 st. first, then knit 6 rows until you have decreased 1 st. 6 x and after each decrease (or increase) have knitted 6 rows (1 st. 8 x + 6 rows 8 x).

Where shapings are given without a boxed number as on most armholes, necklines, etc., make the shapings on every second row (on each side of course).

(See below for more Pattern Stitch Symbols.)

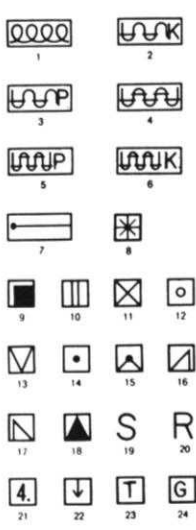

KNITTING PATTERN SYMBOLS

1. Cast on
2. Stockinette stitch - worn on the Knit side
3. Stockinette stitch - worn on the Purl side
4. Knit 1, Purl 1, Ribbing
5. Ribbing Pattern - worn on the Purl side
6. Ribbing Pattern - worn on the Knit side
7. Put on a stitch holder
8. Pattern Stitch
9. Knit Stitch
10. Purl Stitch
11. Needles back into working position
12. Empty needle (leave in working position)
13. Needle not used (in the out of work position)
14. Needle in holding position
15. Two stitches on 1 needle - either transferred from the right side or the left side, then put into holding position
16. Needle holding 2 stitches. Stitch has been transferred from the LEFT
17. Needle holding 2 stitches. Stitch has been transferred from the RIGHT
18. 3 stitches on 1 needle. The 1st and 3rd stitch in a group of 3 needles has been hung on the 2nd or center needle
19. Row
20. Row
21. Number of rows to be knitted between shapings
22. Bind off
23. Tension

24. Gauge
25. Reverse one section
26. On every other needle
27. & 28. Open Dart
29. & 30. Closed Dart
31. Short Row increase or decrease, for instance on flared skirt knitted sideways
32. Pattern stitch - worn on the Knit side
33. Pattern stitch - worn on the Purl side
34. Center of garment section
35. Work 1 (2 etc.) rows single crochet around edges
36. Turn to the wrong side and hem
37. Ease
38. Match numbers on sections for assembling
39. Hem
40. Fold line
41. Color number (example - C1 = Color 1)

The Roman numeral numbers shown on each garment section are as follows:

I	Front
II	Back
III	Sleeve
IV	Skirt Front
V	Skirt Back
VI	Collar
VII	Pocket
VIII	Band
IX	Belt
X	Cuff



it's a knitting table! it's a desk!

Your knitting machine folds away inside this handsome desk and it rises easily, on a spring loaded platform, anytime you wish to use it . . . The desk top slides back out of sight when you are knitting.

No need to dismantle your knitting machine when guests arrive unexpectedly . . . Just fold it back into the desk and you have instant, good looking furniture . .

Beautifully made by West German craftsmen, KNITKING desks are available in three finishes: Natural Walnut, Natural Oak or Natural Fruitwood.

Measurements:

Length - 56½"

Height - 30"

Width 17"

Price F.O.B. Los Angeles

\$189.50

(california residents add sales tax); Freight Charges — F.O.B., Los Angeles.

