

# PASSAP

*Ribbing Attachment*





# Ribbing Attachment

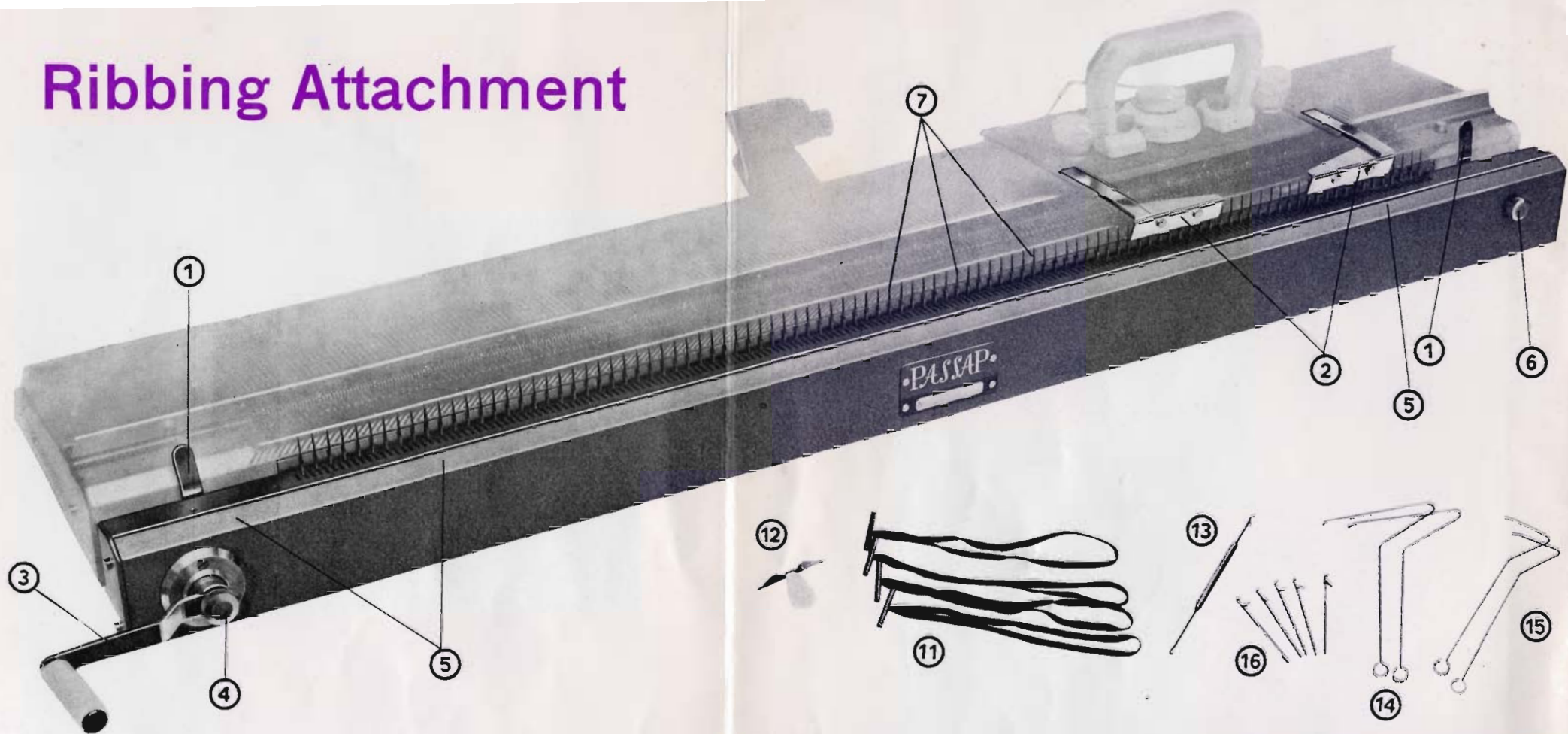

1. **Locking trigger** for opening and closing the fixing brackets when tilting the attachment forward.
2. **Brush supports**, which are fixed on to the lock in place of the stripper.
3. **Operating handle**, for operating the mechanism.
4. **Knurl-headed screw** at the left, for fixing the operating handle after it has been placed in the socket.
5. **Holes marked in red**, points to be oiled after cleaning.
6. **Knurl-headed screw** at the right, for fixing the attachment.
7. **101 latch needles of Group II**, which are in the attachment in a 1-1 division when the attachment is delivered.

8. **Wire**, which is threaded through the teeth of the casting on comb.
9. **Casting on comb** with 100 teeth, and studs on which to hang the elastic guys.
10. **Elastic guys**, with wooden foot rest, which are hung on to the studs of the casting on comb.
11. **Secondary guys**, which are hung on to the lower end of the working hooks when increasing and then fixed into the main guys.
12. **Latch opener**.
13. **Grey handled tool**, at one end a crochet hook, at the other end a latch needle.
14. **Large working hook**, for increasing stitches.
15. **Small working hook**, for increasing stitches.
16. **Spare latch needles**, for Group II.

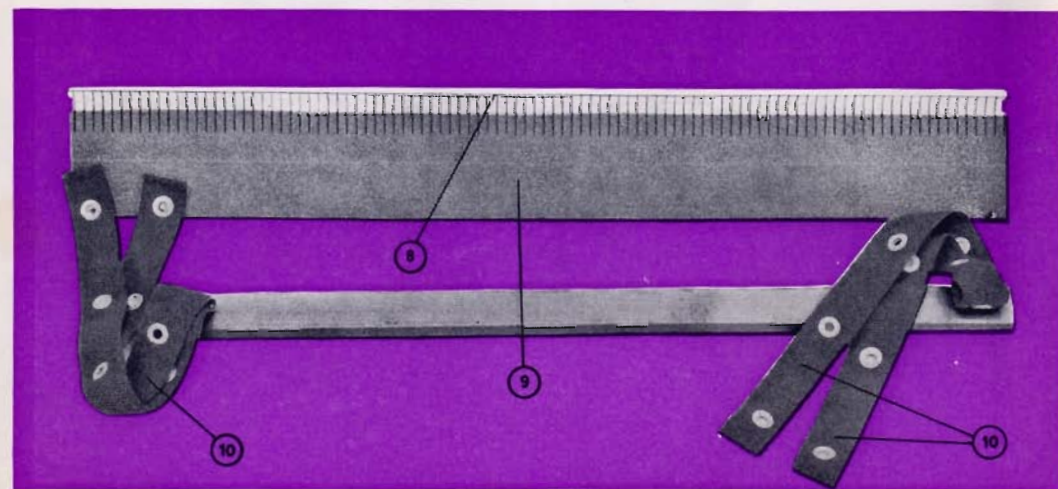



## INDEX

	Page
Assembling the ribbing attachment . . . . .	2-3
Basic patterns . . . . .	12-13
Casting off . . . . .	15
Casting on and knitting . . . . .	6-12
Casting on by hand . . . . .	19
Casting on comb, how to remove from work . . . . .	19
Casting on comb, how to insert . . . . .	6
Casting on for 1 plain-1 purl . . . . .	6-9
Casting on for 2 plain-1 purl . . . . .	9-10
Casting on for 2 plain-2 purl . . . . .	10-11
Casting on for 3 plain-1 purl . . . . .	11-12
Cleaning of attachment . . . . .	25
Cord pattern . . . . .	12
Crocheting dropped stitches . . . . .	17
Decreasing one stitch . . . . .	15
Decreasing several stitches . . . . .	15-16
Dropped stitches, crocheting up . . . . .	17
Elastic guys . . . . .	8,14
Fisherman's rib . . . . .	3
Handle, operation . . . . .	4
Increasing one stitch . . . . .	3
Increasing several stitches . . . . .	14
Introduction . . . . .	1
Knitting . . . . .	9
Oiling of attachment . . . . .	25
Operation of the handle . . . . .	4
Patterns . . . . .	20-23
Ribbing attachment, assembling . . . . .	2-3
Ribbing attachment, cleaning and oiling . . . . .	25
Ribbing attachment, setting up the needles . . . . .	5
Ribbing attachment, tilting . . . . .	5
Secondary guy . . . . .	14
Separating row . . . . .	18
Setting up the needles of the ribbing attachment . . . . .	5
Tilting of ribbing attachment . . . . .	5
Tips . . . . .	24-25
Transferring the stitches of Group II to Group I . . . . .	18

This booklet  
has the Ref. No. 2064 E

6

15

## The Ribbing Attachment for the Passap M 201 Handknitting Machine

Requests from enthusiastic PASSAP knitters all over the world, have led us to develop this, the PASSAP Ribbing Attachment, as an optional addition to the PASSAP M 201. The main purpose of the attachment—as its name suggests—is to enable the owner of a PASSAP M 201 to knit true ribbing quickly and simply.

In addition, however, the Attachment offers virtually unlimited scope for new types of patterns, many of which would be extremely difficult, indeed almost impossible, to produce by hand. The potential programme for the PASSAP owner is, therefore, considerably enlarged. At the end of this instruction booklet you will find a few significant examples for the advanced PASSAP knitter.

The task which we set ourselves in designing and constructing the Ribbing Attachment was in deed formidable. In spite of this, we feel we can say that we have been successful. Here are a few of the worthwhile features which will help you to enjoy many hours of pleasurable, profitable knitting:

- The Attachment can be fitted to every existing PASSAP M 201, and can be easily removed in a few moments.
- The present advantages of the PASSAP M 201 remain at your service with no restrictions.
- Clever engineering enables each of the needles on the Attachment to be moved from one position to another, thus making it possible, for the first time, to produce a Ribbing Attachment which will knit two consecutive Purl stitches.
- Thus amongst other Plain-Purl combinations, double and single sided fisher-man's ribs can be worked in 1 plain-1 purl, 2 plain-1 purl, and 2 plain-2 purl.

Up to now, only very expensive industrial type knitting machines have been able to claim such achievements as these. Nevertheless, PASSAP have succeeded in producing an Attachment in keeping with the accepted high standards of Swiss Precision Engineering at a price which brings it within the reach of the average housewife and homeknitter. With all these advantages we have kept faith with our original motto: the PASSAP M 201, together with Ribbing Attachment, remains a reliable knitting machine for individual, easy and speedy handknitting.

PASSAP-EXPORT ZÜRICH

## The assembling of the ribbing attachment

### Preparation of the sliding lock

Unscrew both hexagon nuts on the stripper (fig. 1), and remove the **stripper** from the sliding lock.

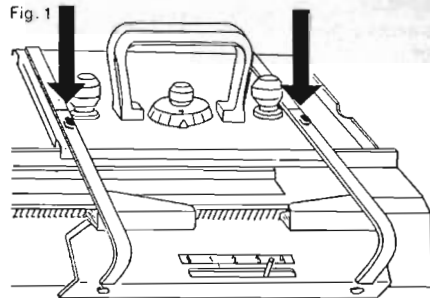

**Fix the brush supports** of the ribbing attachment in place of the stripper (pointing the brushes inwards) and using the same hexagon nuts (fig. 2).

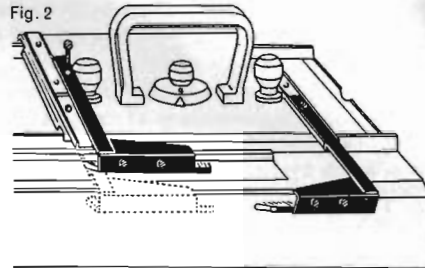

### Preparation of the attachment

Place **machine** so that its front is flush to the edge of the table.

Make sure the fixing brackets at each end of the machine are closed, and that the locking triggers are in the vertical position (fig. 3). See also "How to tilt attachment" (figs. 15 and 16).

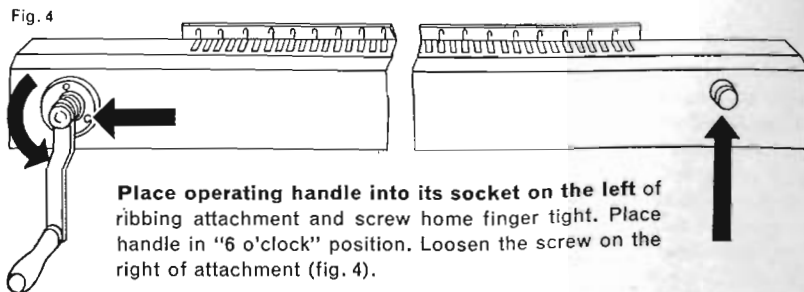
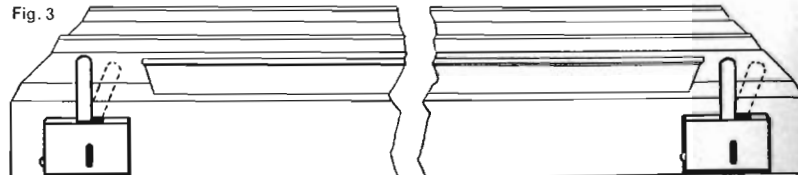

**Place operating handle into its socket on the left of ribbing attachment and screw home finger tight. Place handle in "6 o'clock" position. Loosen the screw on the right of attachment (fig. 4).**

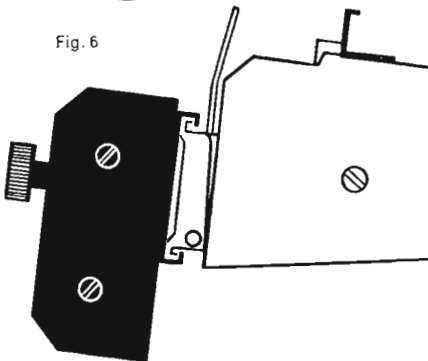
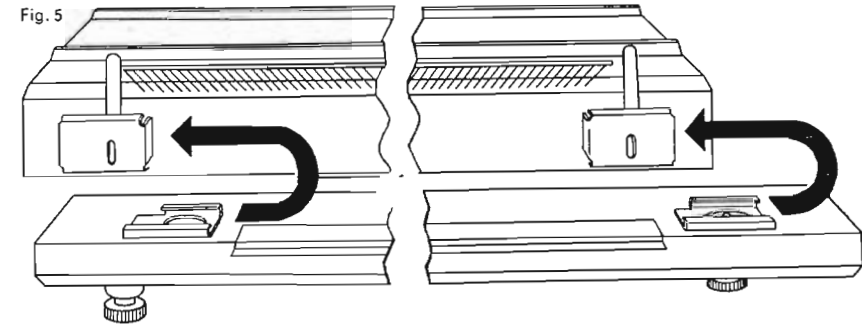

Slide the runners on to the fixing brackets of the machine from right to left, making sure that runners and brackets coincide **EXACTLY**.

Screw home the right hand screw finger tight (figs. 5, 6 and 7).

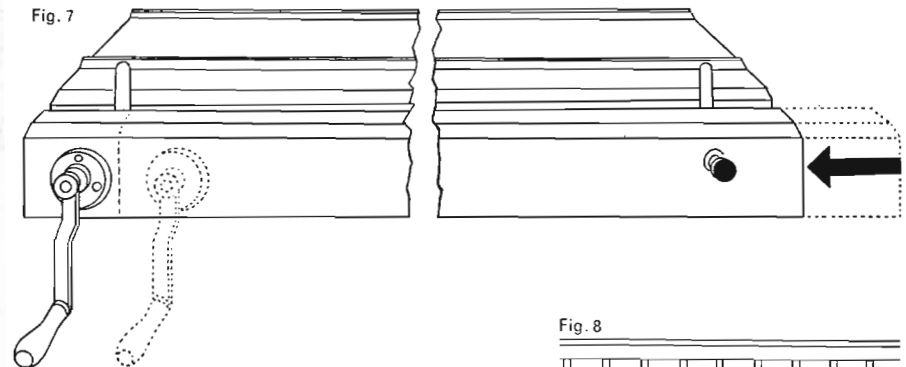

**Important:** Check that the latch needles of ribbing attachment are centred **exactly** between the pins of the striking comb (fig. 8).

**To remove the ribbing attachment reverse this procedure**

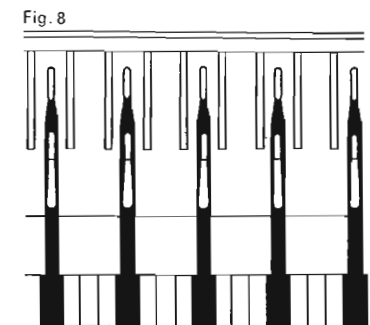

## How to operate the handle

The latch needles on the machine, which move horizontally, will be referred to as: "Group I".

The latch needles on the attachment, which move vertically, will be referred to as: "Group II".

Group I is operated as usual by the sliding lock. Group II is operated by turning the handle anti-clockwise.

After assembly, the operating handle is in the "6 o'clock" position. Movement of the handle will bring Group II into the following positions:

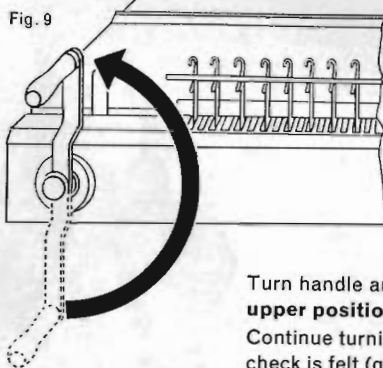

Turn handle anti-clockwise to "12 o'clock" (half circle) = Group II in upper position (fig. 9).

Continue turning handle anti-clockwise to "9 o'clock" position until check is felt (quarter circle) = Group II in working position (fig. 10).

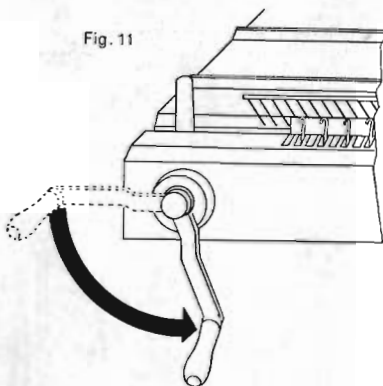
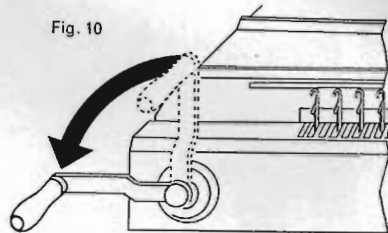

Continue turning handle anti-clockwise until a point slightly to the right of the "6 o'clock" position is reached (quarter circle) = Group II in lower position (fig. 11).

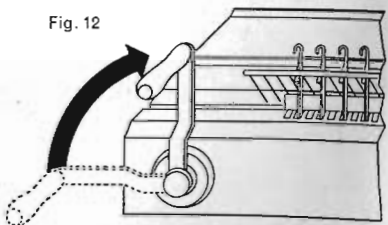

From working position at "9 o'clock" (fig. 10) the handle can also be turned in a clockwise direction (quarter circle) into upper position (fig. 9) overcoming the slight resistance which will be felt as the check is passed (fig. 12).

Beginners should practise these handle movements, to get to know the three positions thoroughly and to get used to the feel of the check.

## The simplicity of setting up the needles

Each needle can be moved quite simply from one socket to another. First make sure that all latches are open, using the "cupid's bow" latch opener provided (fig. 17). Then turn the handle to bring Group II into the upper position as shown in fig. 9.

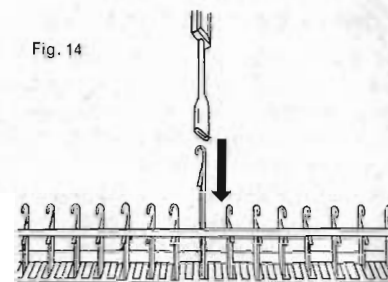
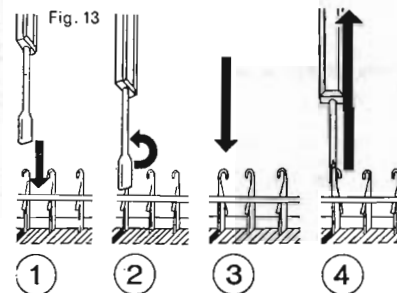

**To Remove a Needle.** Place the cup end of the blue-handled tool on top of the needle head and turn with the needle through 180° so that the needle head points backwards. Remove the tool from the needle head and with the other end (decker needle) grasp the needle from above and lift out vertically from behind the striking comb (fig. 13).—**To replace a needle:** With open latch, place the needle vertically behind the striking comb into the appropriate socket, with the needle head facing forward. Then push downward with cup end of blue-handled tool until needle clicks into place (fig. 14).

### How to tilt the attachment forward for casting off and repair work

First remove feet from wooden bar (see fig. 26).

Move locking triggers of fixing brackets on the machine to the right, thus opening the hinges.

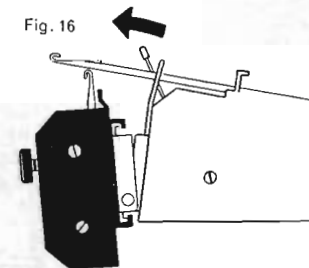

The attachment can now be tilted forward (fig. 15). The top edge of the attachment is now about one inch away from the machine (fig. 16) to facilitate such operations as casting off, crocheting up stitches, repairs, etc.

Before tilting the attachment forward always bring Group I forward into the rest position, leaving Group II in the working or lower position. Before continuing to knit, push the attachment back into position, engage the locking triggers by moving them to the left, and make sure that all latches are open. Bring Group I back into the working position and replace feet on bar.



## How to cast on and knit

There are a number of ways of casting on with the ribbing attachment. Of these we shall first describe the most common method, as it is the easiest and fastest. Casting on by hand is described later, at the end of this book.

### How to cast on for 1 plain - 1 purl

On the attachment, set the needles of Group II in 1—1 division, i. e. a needle in every second socket. Set needles along the whole length of the attachment, as these may be needed later.

Bring Group II into working position as shown in fig. 10. Guide the latch opener with smooth edge along the needle heads, opening the latches (fig. 17).

Bring forward into the working position those needles from Group I which alternate with those set up on Group II. The first and last stitches should be formed by needles from Group I. To ensure that the correct needles are selected from Group I, bring the first needle forward with the cup end of blue-handled tool, and the remainder with the 1—1 division of the pattern ruler (fig. 18).

Move sliding lock slowly across to open latches of Group I and leave at right.

Push Group I back into freemove position with the block ruler, i. e. until needle heads are behind striking comb. Bring Group II into lower position as shown (fig. 19).

Fig. 19

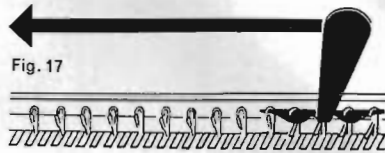
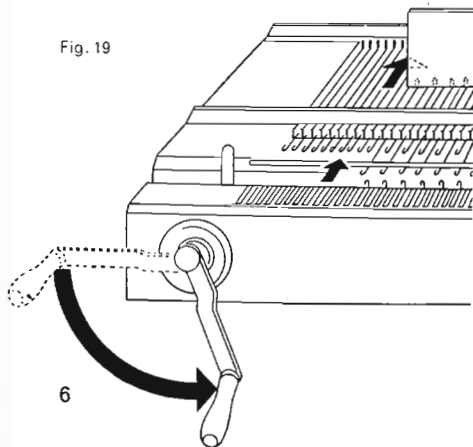

Fig. 17

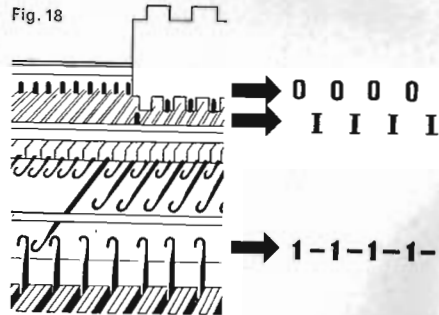

Fig. 18

Push up the casting on comb from below (complete with wire thread) between the machine and attachment, with the teeth of the casting on comb bending forward until they touch the striking comb (figs. 20 and 20a).

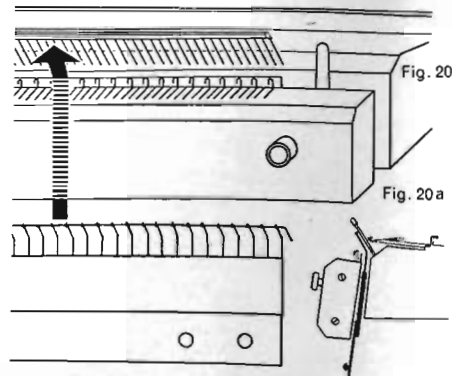

Fig. 20

Fig. 20a

Now, with the block ruler, carefully bring Group I forward into working position until wire lies **behind** the open latches (fig. 21). Bring Group II into working position — three-quarter circle anti-clockwise.

**Important:** There should not be any latches lying below the wire.

Fig. 21

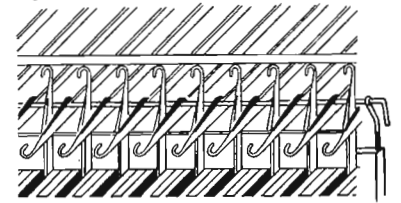
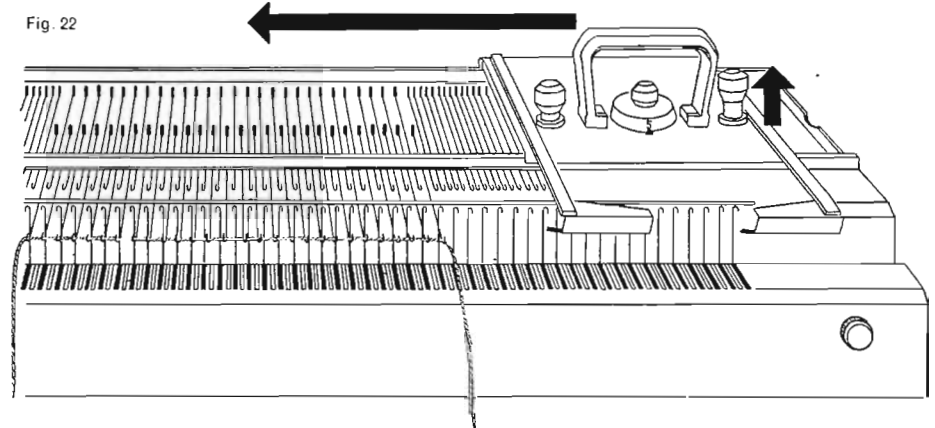
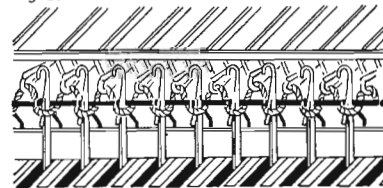

Fig. 22



Set tension adjustment on sliding lock at a high number (e.g. 5 for 3-ply wool). Pull up right freesetter knob. Keeping a free length of about 12 inches in the right hand, lay the wool from right to left across the open Group I latches. Slide the lock slowly to the left (fig. 22), lifting the casting on comb slightly.

Fig. 23



Make sure that lock is at the left. Group I is in freemove position. Group II is still in working position. The wire lies on the arrangement of stitches known as the "zig-zag" (fig. 23).

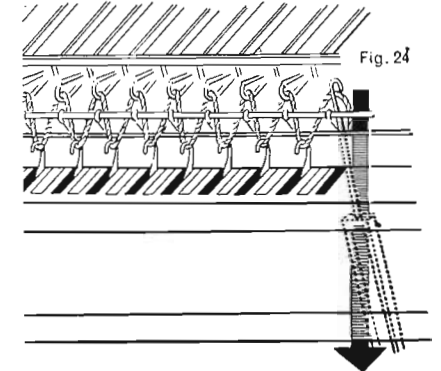
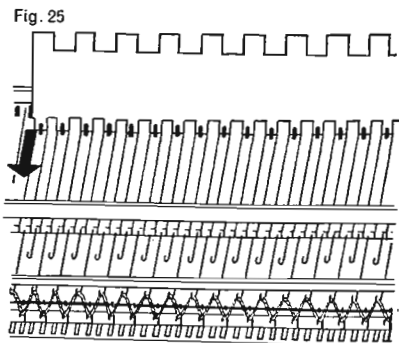

Fig. 24

Bring Group II into lower position as shown in fig. 11 (quarter circle). Lay loose end of wool along the gap between the ribbing attachment and machine, then from below, with the hook end of the grey handled tool, pull wool down (fig. 24). Wind wool around one of the right hand studs at the foot of the casting on comb.



Push Group I forward into working position (fig. 25), and check that all latches are open.

Fix elastic guys into position by placing top eyelets on to the studs at right and left of casting on comb. Extend elastic guys by placing feet on the wooden bar until it rests on the floor (fig. 26).

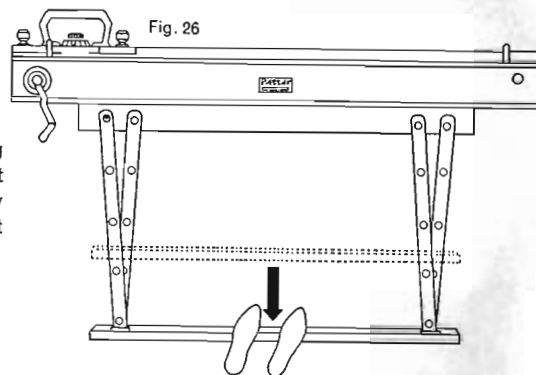

### Shortening the elastic guys

An even downward tension must always be applied to the knitting. As the knitting grows and the guys become slack, readjust them by placing the next set of eyelets on to the studs.

When knitting has grown so long that the guys are no longer taut, even when hung by the lowest eyelets, temporarily remove feet from bar, pull out wire thread from casting on comb, remove the comb from the first row and, from behind, push comb teeth through knitting as high up as possible, then thread the wire through again. Any irregularity which arises will disappear once the finished knitting has been left for a few hours or after light steam pressing.

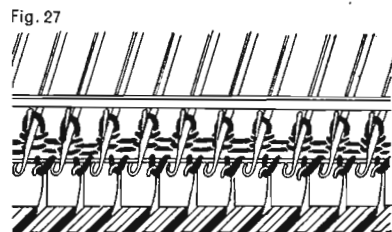

Set tension adjustment on sliding lock at low number (e. g. 2 for 3 ply wool). Push freesetter knob down and knit 2 rows with Group I. These are called "tube rows" (fig. 27).

To continue, bring Group II into working position (three-quarter circle). Set tension adjustment at normal number (e. g. 4½—5 for 3 ply wool).

Set row counter at 0, because the actual knitting now begins.

### How to knit

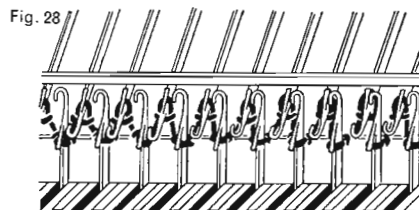

Both groups are in the working position, and the stitches are lying below or behind their respective open latches (fig. 28).

Lay the wool across the needles and slide lock to the other side, knitting the stitches of Group I.

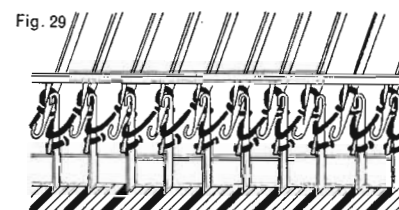

The wool now lies within the open latches of Group II (fig. 29).

Turn handle anti-clockwise until check is felt (full circle), thus knitting the stitches of Group II and bringing the needles back into starting position, as shown in fig. 28.

### How to cast on for 2 plain -1 purl

#### The simple method

Set up the needles of Group II in 2-1 division, i. e. a needle in every third socket.

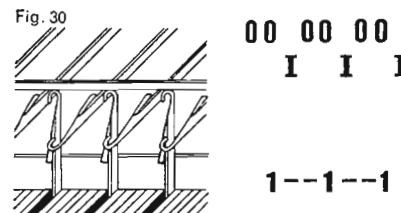

Bring Group II into working position. Open latches (as shown in fig. 17). From Group I bring every third needle forward into working position, as indicated in fig. 30. For bringing the needles forward, use universal pattern selector if at hand: 1 spade out, 2 spades in. Otherwise use cup end of blue handled tool.

Fig. 31

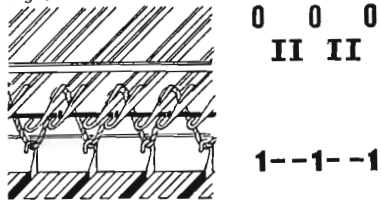

Cast on as for 1 plain — 1 purl (figs. 19—25). Now bring the second needle of each pair from Group I forward into working position, so as to obtain the following: zig-zag extended between the left needles of Group I and the needles of Group II. The wire of the casting on comb lies on the zig-zag. The empty right needles of Group I stand above the zig-zag (fig. 31).

**From here knit as for 1 plain-1 purl (figs. 28 and 29).**

### The special cast on for finer yarns

The previously described simple method of casting on is especially suitable for medium or thick wool, because it results in a flat, thin cast on edge. To obtain a rounded, full edge, especially for fine yarn, it is better to cast on by the following method:

Begin as for simple method up to and including fig. 31; then press freesetter knob down, and bring Group II into working position (three-quarter circle). Now fix elastic guys into position and knit 1 row with both groups, turning handle downward to bring Group II into lower position. Knit the 2 tube rows, described by fig. 32. Continue as for simple method.

## How to cast on for 2 plain-2 purl

### The simple method

Set up the needles of Group II in 2-2 division, i. e. needles in each alternate two sockets.

Fig. 33

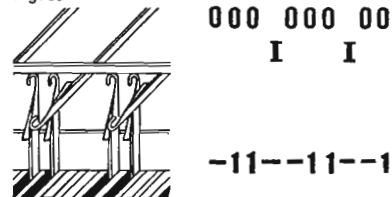

Bring Group II into working position and open latches. Bring forward every 4th needle of Group I into the working position (fig. 33). For bringing the needles forward use universal pattern selector if at hand: 1 spade out, 3 spades in. Otherwise use cup end of blue handled tool.

Fig. 32

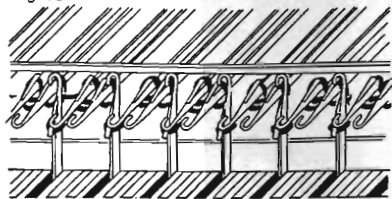

Fix elastic guys into position (as shown in fig. 26). Knit 2 tube rows as for 1 plain — 1 purl (fig. 27). Bring Group II into working position (three-quarter circle) to obtain the following: Both Groups are in the working position and the stitches are lying below or behind their respective latches (fig. 32).

Cast on as for 1 plain — 1 purl (figs. 19—24). Now with the hook end of the grey handled tool, lift the zig-zag out of every right hand needle of Group II (fig. 34).

Bring Group I into the working position. Now bring the second needle of each pair into the working position, so as to obtain the following: zig-zag extended between the left hand needles of both groups, wire of casting on comb lying on the zig-zag. The empty right hand needles of Group I stand above the zig-zag (fig. 35).

Fix elastic guys into position and knit 2 tube rows as for 1 plain — 1 purl (fig. 27). Bring Group II into working position (three-quarter circle) to obtain the following: on Group II the zig-zag now lies below the open latches of each left hand needle and the right hand needles are empty. On Group I the stitches lie behind the open latches (fig. 36).

**From here knit as for 1 plain — 1 purl (figs. 28 and 29).**

### The special cast on for finer yarns

The previously described simple method of casting on is especially suitable for medium or thick wool, because it results in a flat, thin cast on edge. To obtain a rounded, full edge, especially for fine yarn, it is better to cast on by the following method:

Begin as for simple method up to and including fig. 35. Push freesetter knob down, bring Group II into working position

## How to cast on for 3 plain-1 purl

Set up the needles of Group II in 3 — 1 division, i. e. a needle in every 4th socket.

Bring Group II into working position and open latches. Bring forward every 4th needle of Group I into working position, so that they are in the middle of the needles of Group II (fig. 37). For bringing the needles forward use universal pattern selector if at hand: 1 spade out, 3 spades in, otherwise use the cup end of the blue handled tool.

Fig. 34

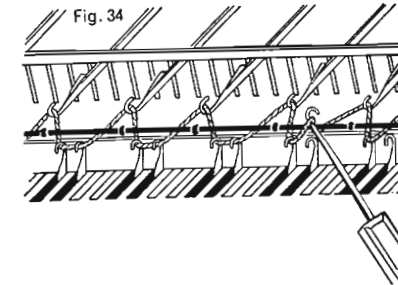

Fig. 35

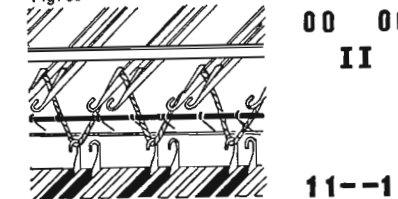
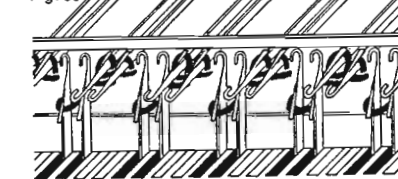

Fig. 36



(three-quarter circle). Now fix elastic guys into position and knit one row with both groups, turning handle (quarter circle) downward to bring Group II into lower position. Now knit the two tube rows (fig. 27). Only now bring Group II into working position (fig. 36). Continue as for simple method.

Fig. 37

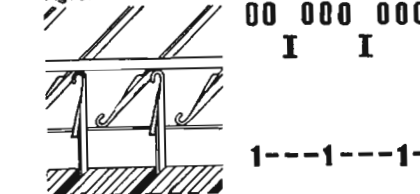
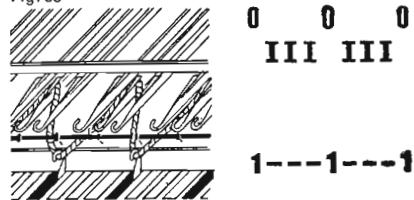



Fig. 38



Cast on as for 1 plain — 1 purl (figs. 19—25). Now bring the first and third needles of each trio of Group I forward into the working position so as to obtain the following: zig-zag extended between the centre needle of each trio of Group I and the needles of Group II. Wire of casting on comb lies on zig-zag. The empty needles right and left of the centre needles of Group I stay above the zig-zag (fig. 38).

Bring Group II into working position (three-quarter circle), push free setter knob down, fix elastic guys into position and knit one row with both groups, turning handle (quarter circle) downward to bring Group II into lower position. Now knit two tube rows (fig. 27). Bring Group II again into working position (three-quarter circle).

**From here knit as for 1 plain — 1 purl. (figs. 28 and 29).**

## Two basic ways of patterning

On Group I patterns are generally formed in the same way as when knitting with the PASSAP M 201, i. e. by varying colours, needle positions and needle divisions. On Group II there are two ways of patterning which can be easily combined with patterns on Group I, giving very pretty designs. Towards the back of this book there are instructions for a variety of patterns. However, the two basic ways of patterning with the ribbing attachment are as follows:

**Horizontal patterning:** is achieved by leaving Group II temporarily in **lower position**. In this way a corded effect is obtained, the so called "wave pattern", i. e. tucks which run across the knitting.

**Vertical patterning:** is achieved by leaving Group II temporarily in **upper position**. In this way the so called "slip stitch pattern" is obtained i. e. patterns where the thread is slipped in one row and only knitted up in the following row, as when knitting fisherman's rib by hand.

### A horizontal pattern: the cord

The cord pattern is most effective when knitted in 1 plain — 1 purl.

Cast on and knit 1st row according to figs. 17—29, then knit a few rows. For the last row, set tension adjustment two or three numbers higher and turn handle (quarter circle) downward to bring Group II into lower position, then reset tension adjustment to normal number. Now knit from 3 to 5 tube rows **with Group I only** (fig. 39), then turn handle to check (three-quarter circle). (Fig. 39a.)

Make sure that on Group II the last stitches lie under the open latches, and 3 to 5 threads lie behind each needle (fig. 39a).

Knit a few rows in the normal way, then repeat from fig. 39; commencing from "For the last row . . ."

Fig. 39

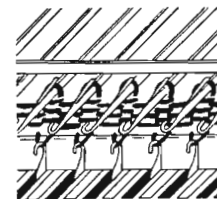

Fig. 39a



### A vertical pattern: simple fisherman's rib

This pattern is equally effective knitted in 1 plain — 1 purl or 2 plain — 1 purl.

Cast on and knit 1st row according to figs. 17 to 29. Turn handle (three-quarter circle) to bring Group II into the upper position. (If, by mistake, the handle has been turned right through to check, it can be turned backwards to bring Group II into upper position, according to fig. 12). Knit 1 row with Group I (fig. 40). Now turn handle (quarter circle) to check (fig. 40a).

Fig. 40

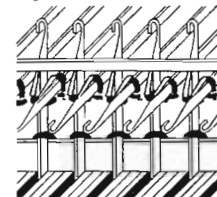
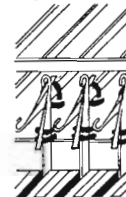

Fig. 40a



Make sure that the last stitch and one slipped thread lie under the open latch of each needle of Group II (fig. 40a). Knit 1 row normally with both groups, then repeat from fig. 40.

## How to increase

### Increasing one stitch

As the end stitches are usually formed by Group I needles, we describe first how to increase a stitch on a Group II needle.

**Group II needle:** If sliding lock and wool are at the right of the machine, increase at right and vice versa: make sure that the latch of the new Group II needle is open. Now, whilst turning the operating handle and as Group II passes the lower position, place wool behind the head of the new needle (fig. 41). Continue turning until Group II regains the working position. Lay wool across the open latches, so that it is carried around the new needle (fig. 41a).

Fig. 41

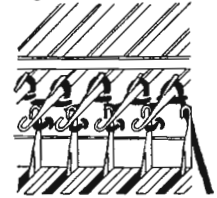
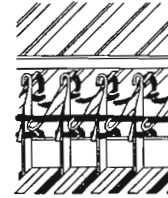
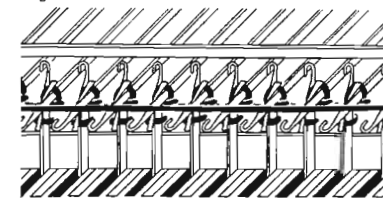

Fig. 41a



**Group I needle:** If sliding lock and wool are at the right of the machine, increase at right, and vice versa. Bring new needle into working position and open latch. Bring wool around new needle and lay across the open latches of Group I in the normal way (fig. 42).

Fig. 42



## How to increase several stitches

**Example:** In a 1 plain — 1 purl pattern, instructions read "Cast on 10 stitches at beginning of next row". This means that 5 stitches of Group I and 5 of Group II are to be increased.

Fig. 43

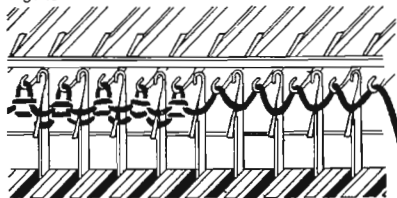

Assuming that wool and lock are on the left, bring 5 needles at the right hand side of Group I into working position. Open latches. Pull left freesetter knob up, lay wool across and slide lock to the right.

Make sure that Group I is in free move position. Between the 5 new needles of Group I and the 5 new needles of Group II the wool is extended in a loose zig-zag (fig. 43).

Holding new needles of Group I in position with the block ruler or by hand, bring Group II into lower position (quarter circle). Still holding new needles of Group I in position, insert the small wire working hook from the right with the angled portion uppermost and with the point facing inward. Guide the hook upward between machine and attachment and lay it over the zig-zag. Put end of working hook into the existing row of stitches (fig. 44).

Fig. 44

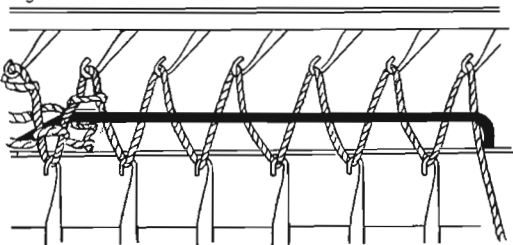

**Important:** Make sure that the working hook lies only on the zig-zag threads without touching the body of the attachment or the needles of Group II. Otherwise it would get caught and result in dropped stitches.

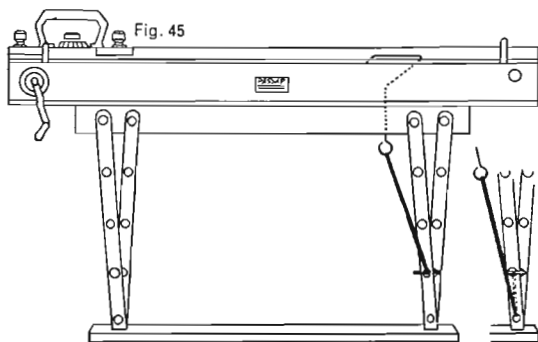

Fix loop end of secondary guy on to lower end of working hook and insert tube end into the next to last eyelet in the main guy, so that secondary guy is taut (fig. 45).

When increasing a larger number of stitches (e. g. 10 on each group), use the larger wire working hook and pass tube end of secondary guy through lowest eyelet in main guy and up into a higher eyelet. As the knitting grows, the secondary guys must always be moved on to keep them taut.

To continue knitting, bring Group I into working position with block ruler, and make sure that all latches are open. Turn handle (three-quarter circle) to working position. Push freesetter knob down.

**For increasing at the left hand side of the work, reverse the above procedure.**

## How to decrease and cast off

### How to decrease one stitch

This can be done at both ends of the same row of knitting if required.

**Group I needle:** Whilst turning the handle to knit the preceding row, and as Group II passes the lower position, take end stitch from Group I on to hook end of grey handled tool and place it on to the next needle of Group II (fig. 46). Continue turning handle to check. Push empty Group I needle back into neutral position. Continue to knit.

Fig. 46

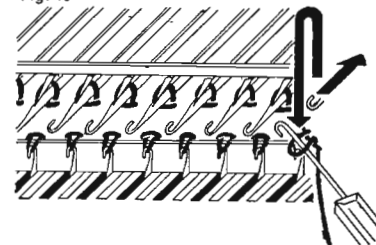

**Group II needle:** Whilst knitting preceding row turn handle quarter circle to bring Group II into lower position. Then place end stitch from Group II on to next needle of Group I, placing it behind the open latch (fig. 47). Turn handle (three-quarter circle) to check. Continue to knit.

Fig. 47

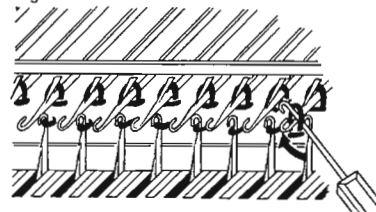

### Casting off and decreasing several stitches

For this procedure there are two basic methods:

1. **Casting away**, leaving a series of open stitches.
2. **Casting off**, leaving a series of closed stitches.

Below is an example of how to decrease 10 stitches in a 1 plain — 1 purl pattern at the right hand side of the work, 5 from Group I and 5 from Group II.

Fig. 48

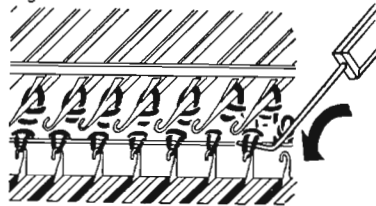

**Casting away open stitches.** Lock and wool at left hand side. Whilst knitting the preceding row, turn the handle quarter circle down to bring Group II into the lower position. Remove feet from wooden bar. Now lift the stitches, one by one, from the 5 outside needles of Group II (fig. 48).

Fig. 49

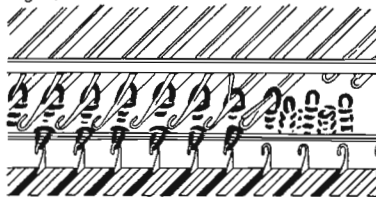

Then push back the 5 outside needles of Group I into the neutral position, allowing the stitches to fall off (fig. 49). Now turn the handle to check, replace feet on bar and continue to knit.

As this procedure leaves open stitches, it is best to knit two or four additional rows beforehand, using a contrasting wool over those stitches which are to be cast away. When the knitting is finished, undo these supplementary rows, pick up the stitches and then cast off by hand or over-sew.

**For decreasing at the left, reverse this procedure.**

To remove the whole of the knitting from the machine with open stitches, remove feet from bar and, without laying the wool across, turn the handle a full circle and slide lock to other side, supporting the casting on comb in the hand.

### Casting off with closed stitches

Lock and wool are at the **right** hand side. Remove feet from bar. Bring Group I forward into the rest position, leaving Group II in the working position. Tilt the attachment forward, as figs. 15 and 16. The stitches of Group II will then slide upwards, closing the latches.

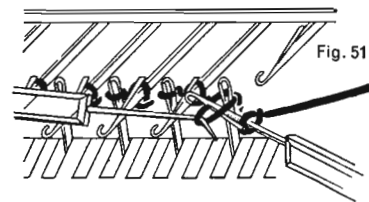
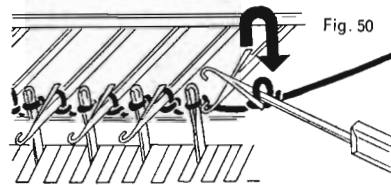

Take the end stitch from Group I on to latch end of grey handled tool, holding the wool **behind** the tool (fig. 50).

Now take the corresponding end stitch from Group II on to the same tool (fig. 51). (To ease, first lift the stitch slightly with the pointed end of the red handled tool.)

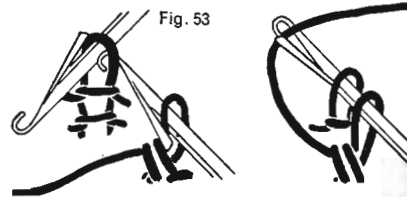
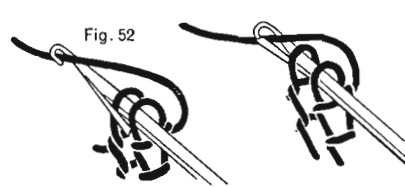

Slide both stitches behind the open latch of the tool, and bring the wool **from behind** into the latch head. Crochet through the two stitches (fig. 52).

Holding wool **in front** of tool, pick up next stitch from Group I and crochet both stitches through, after laying the wool **from the front** into the open latch head (fig. 53). Then again hold the wool **behind** the tool and continue to cast off according to figs. 51 to 53.

This method results in a neat finished edge, just like handknitting. **When not casting off the whole row**, proceed as follows:

The last cast off stitch should be from Group II as shown in figs. 51–52. Lay the new stitch thus formed behind the open latch of end needle on Group I (fig. 54). As this results in another decrease, one stitch less than the desired number is always crocheted through.

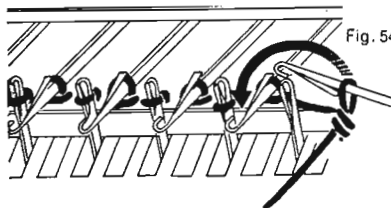

**When the casting off is finished** first open all latches of Group I, push the attachment back into position, and engage the locking triggers. Open all the latches on Group II, then push Group I back into the working position. Replace feet on wooden bar and continue to knit.

## Crocheting up dropped stitches

### Crocheting up dropped stitches from Group I

As soon as the mistake is discovered, knit one more complete row, turning the handle a quarter circle only to bring Group II into the lower position. Remove feet from wooden bar. Bring Group I forward into rest position and tilt attachment forward, as shown in figs. 15 and 16.

Guide the latch end of the grey handled tool down **behind** the knitting and with the needle head pointing forward (i. e. facing the knitting) catch up the stitch. Now crochet up the stitch thread by thread (fig. 55). (To ease, first lift the next thread slightly with the pointed end of the red handled tool.)

Place final stitch on to the appropriate needle of Group I (fig. 56). To continue open all latches of Group I push the attachment back into position, and engage the locking triggers. Bring both groups into working position and replace feet on wooden bar.

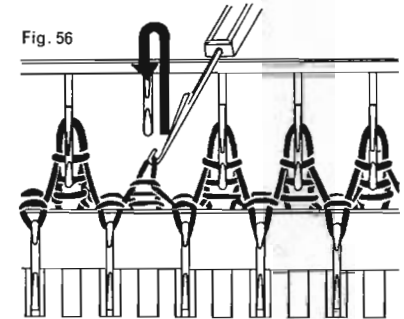
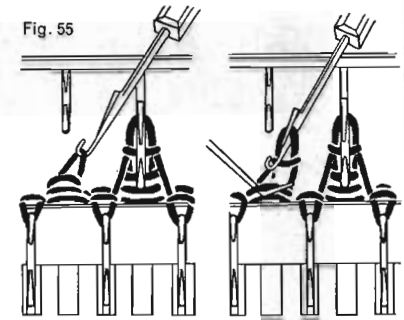

### Crocheting up dropped stitches from Group II

Tilt the attachment forward, as shown in figs. 15 and 16. Bring Group II into upper position. Remove feet from bar and take out the empty needle of Group II, as shown in fig. 13. Now guide the latch end of the grey handled tool down **in front** of the knitting and catch up the stitch, pointing the needle head backward to face the knitting. Crochet up the stitch, thread by thread (fig. 57). (To ease, first lift the next thread with the pointed end of the red handled tool.)

Lastly, push shaft of empty needle of Group II down through the top stitch and, according to fig. 14, replace in its socket (fig. 58).

To continue, open the latches of Group I. Bring Group II into working position and open latches. Only then, push the attachment back into position and engage the locking triggers. Finally, push Group I back into working position, replace feet on wooden bar and continue to knit.

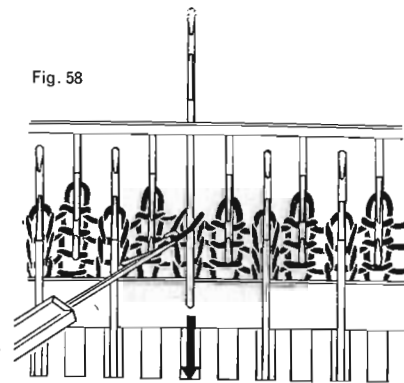
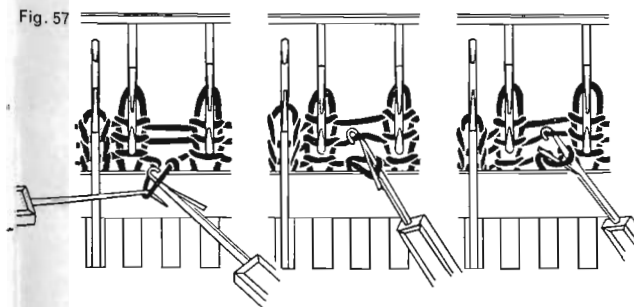

Fig. 58



## The separating row

The advantage of the separating row is that two or more welts can be knitted one after the other, without casting on afresh. The welts of the back and front of a pullover are thus knitted.

Knit the chosen length of the first welt. When knitting the last row turn the handle quarter circle to bring Group II into the lower position. Now knit two tube rows with Group I, then return Group II to the working position.

Remove feet from wooden bar. With block ruler, move Group I back into the neutral position. The stitches will then fall off the needles. Immediately return the empty needles of Group I to the working position and open latches. Pull up the outside freesetter knob. Lay wool across, and slide lock to other side to form a new zig-zag. Hold Group I needle feet in freemove position with the block ruler. With the other hand, bring Group II into lower position. With block ruler, bring Group I forward into working position. Set tension adjustment at a low number, push freesetter knob down and replace feet on wooden bar. Now knit a further two tube rows with Group I.

Bring Group II into working position again, reset tension adjustment at a normal number and continue to knit.

When the chosen length of the second welt has also been reached, cast away the stitches. Both welts hang loosely together and are only connected by the separating row. They are disconnected by cutting the separating thread on both sides and pulling it out (fig. 59). Both welts now have a neat cast-on edge and an open row of stitches. These will later be placed on to Group I, after having removed the attachment, for continuing to knit in stocking stitch.

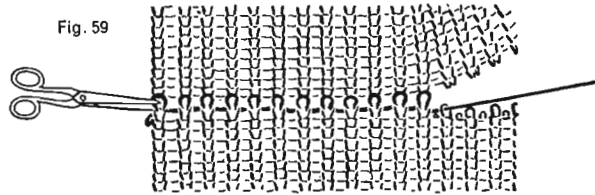

## Transferring the stitches from Group II to Group I

The majority of garment designs call for only the welt to be knitted on the ribbing attachment and the rest of the garment on the PASSAP M201 as usual. Therefore when the welt is completed, the stitches from Group II must be transferred to the needles of Group I.

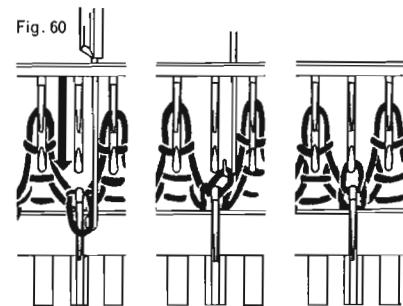

After the final row of ribbing has been knitted and both groups returned to the working position, remove the elastic guys, and bring Group II into lower position, so that the stitches lie around the closed latches.

With the hooked end of the grey handled tool, transfer each stitch from Group II on to the corresponding needle of Group I. To achieve this guide the tool from behind, through the striking comb, grasp stitch and, with a little jerk, place into the waiting needle (fig. 60).

This manipulation is purely a matter of practice and should soon be mastered.

## Removing the casting on comb

After finishing the ribbing, support the casting on comb with the left hand, and pull out the wire thread with the right. Remove work from the teeth of the casting on comb, replace the wire and lay the comb aside. Should the cast on row of ribbing be somewhat wavy, draw up the loose end of wool and ease into shape, until the stitches in the first row lie smoothly side by side.

## Casting on by hand

### Casting on by hand

Tilt the attachment forward and set Group II so that the tips of the open latches touch the top of the attachment structure (handle right). Push Group I forward so that the tips of the needles of both groups are about  $\frac{1}{2}$  of an inch apart. Support the needle feet of Group I from both sides (block ruler behind, an ordinary ruler in front). Now cast on:

Laying in the wool for 1-1 division (fig. 61)

Laying in the wool for 2-1 division (fig. 62)

Laying in the wool for 2-2 division (fig. 63)

Now, from below, hold the casting on comb without the wire between the zig-zag threads of the lain in wool, then push the wire through from the side. Lock the attachment back in place. Bring both groups into working position, check that all latches are open, fix elastic guys into place and knit.

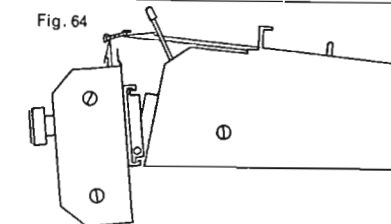
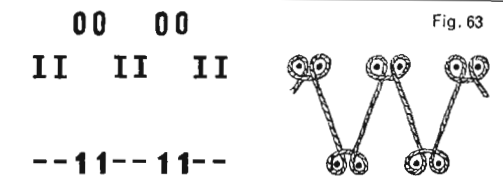

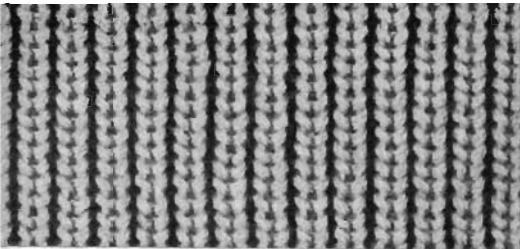

B

### PATTERN B 1

**One-sided fisherman's rib in 1 plain - 1 purl** (needle division as fig. 18)

**One coloured:** Knit according to figs. 40 and 40a. The top picture shows the Group I side of knitting.

**Two coloured:** Basic colour red, trimming colour white.

*1st row white:* Knit with Group I only, leaving Group II in the upper position, as fig. 40.

*2nd row red:* Turn handle to check (quarter circle) and pull up outside freesetter knob. Knit normally with both groups, as fig. 40a. Then push freesetter knob down and bring lock back. — Repeat both rows continuously. The lower picture shows the Group II side of knitting.

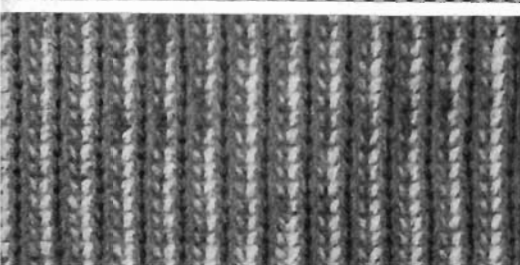

1

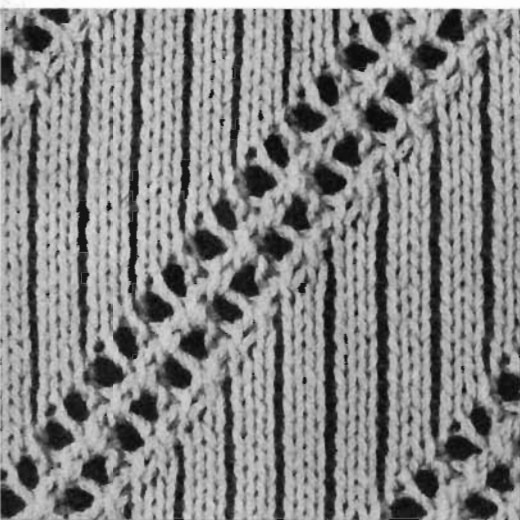

B  
2

### PATTERN B 2

**Diagonal lace stripes in 2 plain-1 purl** (needle division as fig. 31)

When knitting the last row before pattern commences, turn the handle only a quarter circle so as to bring Group II into lower position. Remove feet from bar.

*1st row:* on Group I leave both end stitches and then place the 3rd stitch on to the 4th stitch, and the 5th stitch on to the 6th stitch, \* leave 10 sts. and then place the 11th st. on to the 12th st. and the 13th st. on to the 14th st. \*. Repeat description between the two \*. For placing the sts. over use the hooked end of grey handled tool. Now push the empty needles back into working position, and open latches. Bring Group II into working position. Replace feet on bar and knit two rows. On the last row bring Group II into lower position and remove feet from bar.

*2nd row:* as the first, but start transferring one stitch further along the row. Therefore, first place the 4th st. on to the 5th st. and the 6th st. on to the 7th st., leave 10 sts. etc. Thus the stitches which are transferred are always stretched across the needles of Group II. Take care not to catch the stitch in the hook of the needle of Group II. Repeat both rows alternately, always moving the pattern 1 st. of Group I sideways. The picture shows the Group I side of knitting.

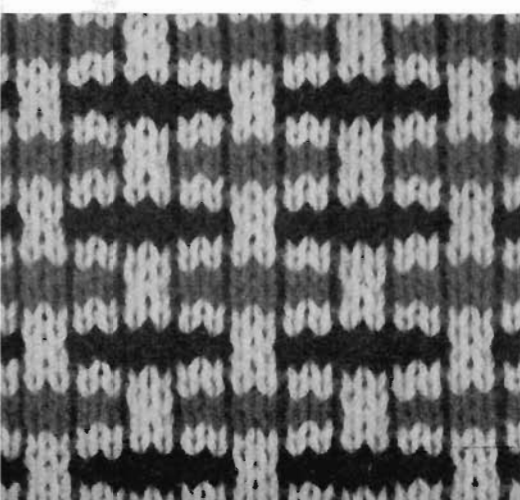

B  
3

### PATTERN B 3

**Three coloured pattern in 2 plain - 1 purl** (needle division as fig. 31)

Basic colour white, trimming colours red and blue.

\*Knit 2 rows normally in white as figs. 28 and 29.

Then from Group I push every 7th and 8th needles forward into the rest position and knit 2 rows red as figs. 28 and 29. Push the needles of Group I back into the working position and knit 2 rows in white. Now reverse, i. e. first the 3rd and 4th needles, and then every 7th and 8th needle into the rest position and knit 2 rows blue. Push the needles back and repeat from \*. The picture shows the Group I side of knitting.

B  
4

### PATTERN B 4

**Lace pattern in 2 plain-1 purl** (needle division as fig. 31)

When knitting the last row before pattern, turn the handle only a quarter circle to bring Group II into lower position. Remove feet from bar.

*1st row:* On Group I leave 8 sts., place the 9th st. on to the 10th st. and the 11th st. on to the 12th st., the 15th st. on to the 16th st. and the 17th st. on to the 18th st., leave 8 sts. etc. Bring Group II into working position (three quarter circle), replace feet on bar and knit 1 row, bringing Group II into lower position. Remove feet from bar.

*2nd and 3rd rows:* as the first.

Then knit 1 row normally, according to figs. 28 and 29.

*4th, 5th, and 6th rows:* as the first, but in reverse order, i. e. place the 10th st. on to the 9th st. and the 12th st. on to the 11th st. and the 16th st. on to the 15th st. and the 18th st. on to the 17th st. Knit 1 row normally and then repeat from the 1st row.

B  
5

### PATTERN B 5

**One-sided fisherman's rib in 2 plain - 1 purl, three coloured** (needle division as fig. 31)

Basic colour white, trimming colours red and blue.

Knit as for Pattern B 1 two coloured, but in view of the colour changes use freesetter knob only when white and the following colour are on the same side.

Colour order as follows: red as fig. 40, white as fig. 40a, blue as fig. 40, white as fig. 40a etc. The top picture shows the Group I side, the lower, the Group II side of knitting.

B  
6

### PATTERN B 6

**Double-sided fisherman's rib in 1 plain-1 purl** (needle division as fig. 18)

Place feather combs across the whole width of the knitting. Starting position: lock and

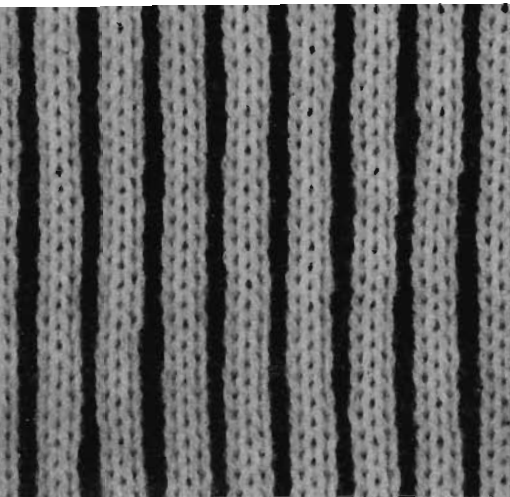

B  
7

wool at left hand side of machine. Pull and leave up left freesetter knob.

*1st row:* \* Lay in the wool, slide lock to the right, three-quarter handle turn to bring Group II into upper position. With block ruler bring Group I from freemove position into working position. Pull up right freesetter knob.

*2nd row:* Lay in the wool and slide lock to left. Now push right freesetter knob down (leave left knob up!), push Group I half forward with the block ruler, so that the stitches lie on the open latches. Turn handle quarter circle, bringing Group II into working position. Repeat from \*. If suitable for the wool, set adjustment disc on 5 or higher. You then can leave both freesetter knobs up all the time. With this pattern both sides look alike.

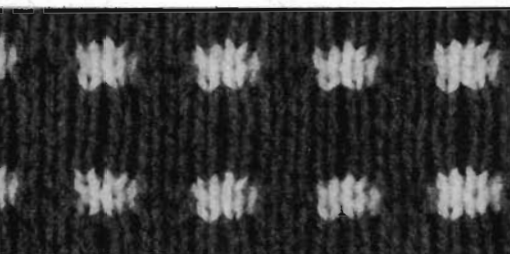

B  
8

**PATTERN B 7**

**One-sided fisherman's rib in 2 plain - 2 purl, two coloured**

(needle division as fig. 35)

Basic colour white, trimming colour red.

Knit as for Pattern B 1 two coloured, but 1st row red, 2nd row white. The picture shows the Group II side of knitting.

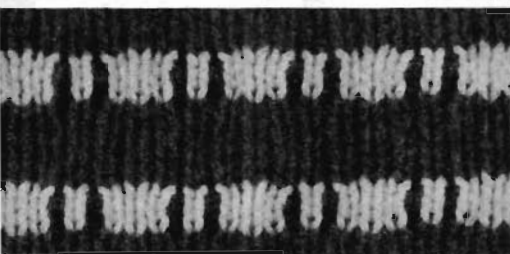

**PATTERN B 8**

**Two coloured pattern in 1 plain-1 purl**  
(needle division as fig. 18)

Basic colour red, trimming colour white.

\* Knit 6 rows normally in red, as figs. 28 and 29. Then from Group I bring every 3rd and 4th needle forward into the rest position and knit 4 rows in white, as figs. 28 and 29. Now push needles of Group I back into the working position and repeat from \*. The top picture shows the Group I side, the lower the Group II side of knitting.

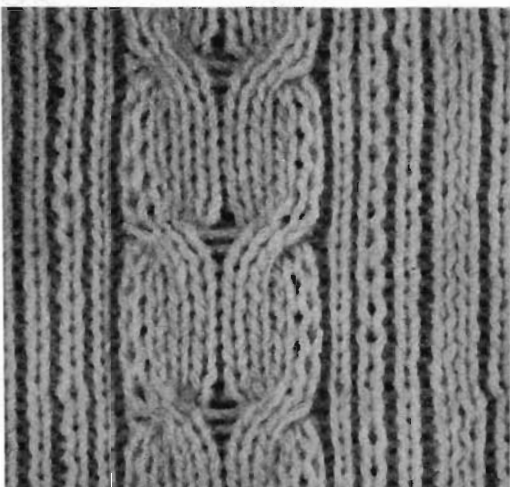

B  
9

**PATTERN B 9**

**Double cable on a plain-purl background**  
Needle divisions as follows:

*Group I:*

o  
| | | | | | | | | | | | | | | | | | | | | |

*Group II:*

--1-1-1-1--1-1-1-1-1-1-----11-1-1-1-1--1-1-1-1--

\* Knit 10 rows normally, then pull up outside freesetter knob and knit 1 more row, turning

the handle only a quarter circle, to bring Group II into lower position. Group I is in freemove position. Remove feet from bar. Now cross the 8 sts. of Group I from the centre outwards in two cables of 4 sts.: take the first four stitches on to two double needles. First place the 3rd and 4th sts. on to the 1st and 2nd needles and then the 1st and 2nd sts. on to the 3rd and 4th needles. Now take the second 4 stitches on to two double decker needles. First place the 5th and 6th sts. on to the 7th and 8th needles and the 7th and 8th sts. on to the 5th and 6th needles. Push Group I forward into working position, Group II into working position (three-quarter circle). Replace feet on bar and repeat from \*. The picture shows the Group I side of knitting.

B  
10

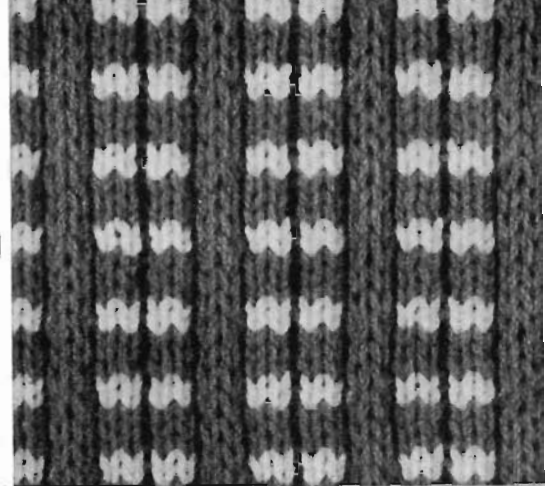

**PATTERN B 10**

**Two coloured pattern in 2 plain - 1 purl**  
(needle division as fig. 31)

Basic colour red, trimming colour white.

\*Knit 3 rows normally in red, as figs. 28 and 29. Then from Group I bring every 3rd and 4th and 9th and 10th needles etc. forward into the rest position and knit 2 rows white as figs. 28 and 29. Now push the needles of Group I back into working position and repeat from\*. The picture shows the Group I side of knitting.

B  
11

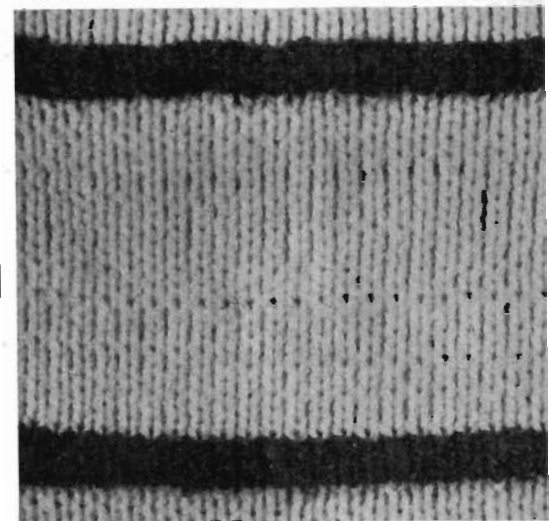

**PATTERN B 11**

**The "wave" or "cord" in 1 plain - 1 purl, two coloured**

(needle division as fig. 18)

Basic colour white, trimming colour green.

Knit a few rows in white as figs. 28 and 29, then according to fig. 39 knit 3-5 tube rows in green. Bring Group II into the working position, according to fig. 39a. Repeat. The picture shows the Group I side of knitting.

**PATTERN B 12**

**One colour pattern variation on 2 plain-1 purl**

(needle division as fig. 31)

\* Knit 5 rows normally, as figs. 28 and 29. Then from Group I bring every 3rd and 4th needle forward into rest position and knit 2 rows, as figs. 28 and 29. Push needles of Group I back into working position. Repeat from \*. The picture shows the Group II side of knitting.

B  
12

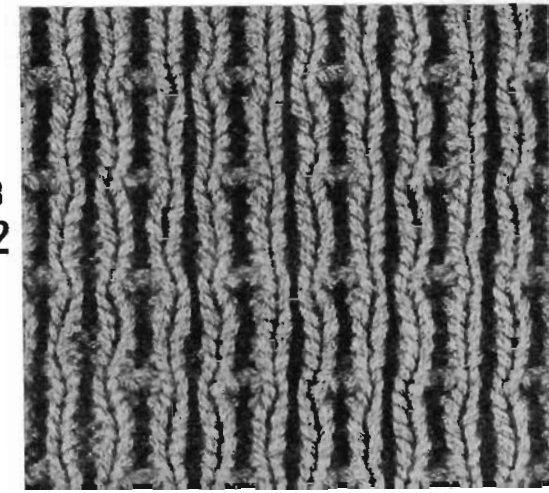



## ... AND FINALLY, A FEW TIPS

**Which is the "right side"?** As, when knitting with the ribbing attachment both sides of the knitting result in attractive and often different patterns, we avoid the terms "right side" and "wrong side". We leave it entirely up to the knitter to decide which side of the knitting pleases her most. Thus she chooses her own "right side".

**The Group I side** refers to the surface of the knitting which faces the machine whilst work is being done.

**Group II side** refers to the surface of the knitting which faces the attachment (and, therefore, the knitter) whilst work is being done.

Bear this in mind particularly when producing shaped pieces of work, as the edge to be shaped will naturally vary according to the side of the fabric which you have chosen as the "pattern" side.

**When transferring the stitches of Group II** on to the needles of Group I one can also proceed as follows: remove the Group II needle from its socket on the attachment (stitch remains on the needle shaft), then link the hook of this needle with that of the Group I needle and lift up the shaft of the Group II needle, until the stitch slides over the automatically closed latch, on to the Group I needle.

**The use of the working hook for side increases.** When several groups of stitches are to be increased one after the other, one can easily use one working hook for two or more groups. For the first group, lay in the working hook according to fig. 44. For the second group, pull out this hook and then immediately replace it, so that it covers both groups. The large working hook can hold up to 24 newly increased stitches (which may be in several groups). The small working hook can hold up to 10 newly increased stitches.

**Casting away open stitches** is not recommended for decreasing by degrees in a slanting line. On the other hand, it is useful for instance, in neckline shaping or pocket openings etc. where a plain knitted border is later to be knitted on.

**If the edge stitches fail to knit perfectly,** the reason is probably that you have held the wool too loosely. After each row you should make a habit of pulling the wool horizontally, so that the last stitches tighten on the needles. If you pull the wool exactly horizontally, the latches remain open and the stitches will be correctly knitted up in the next row.

**Before starting your garment** you can safely place Group II needles in their sockets, in the chosen division, over the whole length of the attachment, as only where there are also needles of Group I in working position will the Group II be knitted. If all the needles are placed in the attachment from the beginning, you will save time later when increasing.

---

## Cleaning and oiling the ribbing attachment

**1. Cleaning.** Although the internal mechanism of the attachment is enclosed, we recommend that the attachment be cleaned from time to time, for instance, once a month. Remove all Group II needles and guide a vacuum cleaner along the empty needle sockets to remove all wool fibres. Also guide the vacuum cleaner across the holes underneath the attachment.

**2. Oiling.** After cleaning administer three drops of PASSAP-BELLODOR-OIL or a fine sewing machine oil into the three oil holes, marked in red. Then replace all needles and turn the handle several times, so that the oil penetrates into the mechanism.

---

## Key to pattern division diagrams

### Group I needle division

0 = needle in neutral position.

1 = needle in working position.

\* = needle temporarily in rest position.

### Group II needle division

1 = place needle in attachment.

- = no needle in attachment.

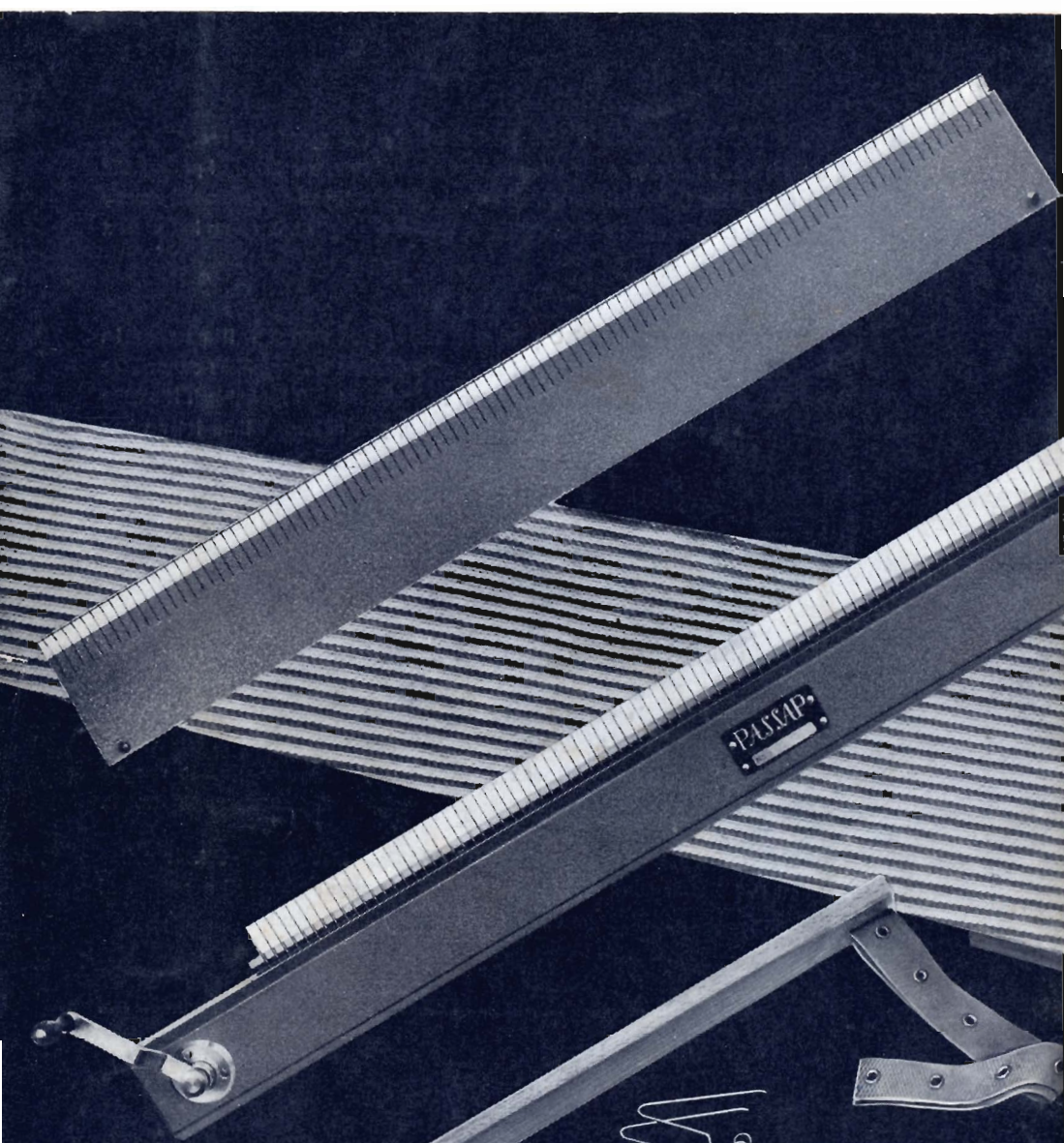

**PASSAP-Export Zurich (Switzerland)**

Zurich 27, Bederstr. 1, Post Box 350, Cable address: Collux, Zurich

**PASSAP LONDON W.1.**

180—182 a, Tottenham Court Rd.