

INSTRUCTION MANUAL

FOR

TOYOTA RIB KNITTER

MODEL **K450**



TOYOTA

CONTENTS

1. Parts Name and How to Use	1
2. Accessories Name and How to Use Accessories	6
3. How to Set Rib Knitter to Main Knitter	9
4. Basic Knowledge for Rib Knitter	14
5. How to Knit	
(1) Casting on and Finished Cast-on	15
(2) One-Knit One-Purl Rib	18
(3) Two-Knit Two-Purl Rib	19
(4) Circular Plain Stitch	20
(5) Close Rib	21
(6) Single Fisherman's Rib	22
(7) Double Fisherman's Rib	23
(8) Swing Pattern Stitch	24
(9) Rippling Waves Pattern Stitch	25
(10) Pin Tuck Pattern Stitch	26
(11) Tuck Stitch	27
(12) One Side Two Colour Knitting	28
(13) Partial Knitting of Ribbing	
1) Partial Knitting of One-Knit One-Purl Rib, and Two-Knit Two-Purl Rib	30
2) Partial Knitting of Single Fisherman's Rib and Double Fisherman's Rib	32
3) Partial Knitting of Swing Pattern Stitches and Rippling Waves Pattern Stitches	33
4) Partial Knitting of Tuck Stitches	35
(14) Increasing and Decreasing Rib Stitches	37
6. In Such Cases	39
7. How to Take Care of the Machine	42

1. PARTS NAME AND HOW TO USE

Ribbing Carriage

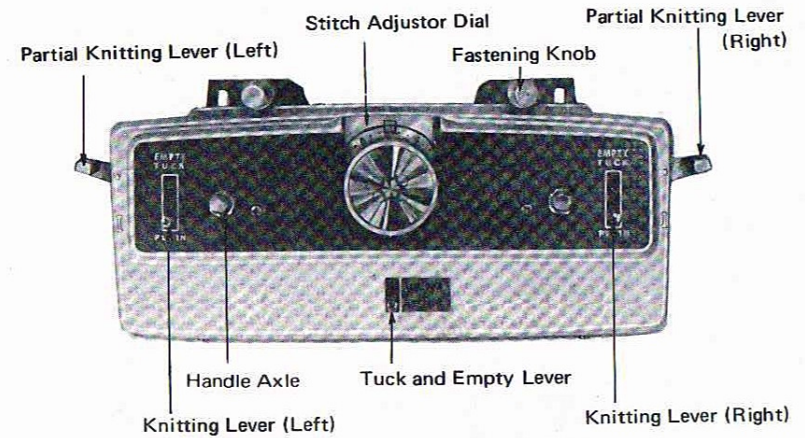

(1) Knitting Lever

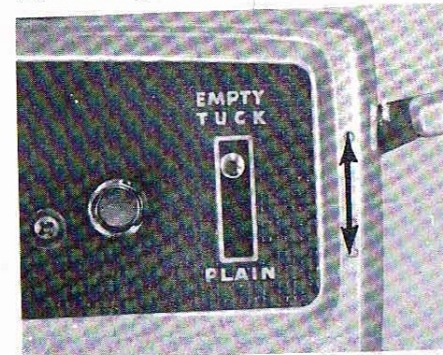

Set Knitting lever at PLAIN for plain knitting, and at EMPTY or TUCK for single fisherman's rib, double fisherman's rib, circular plain stitch and pin tuck pattern.

(2) Tuck and Empty Lever

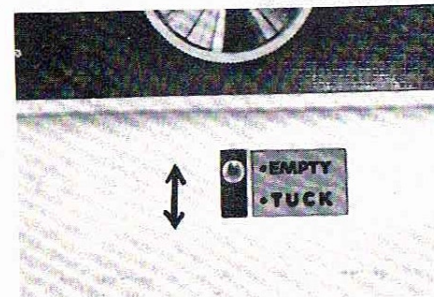

Set Tuck and Empty lever at TUCK for single fisherman's rib and double fisherman's rib.

Set it at EMPTY for circular plain stitch, pin tuck stitch and one side color figured knitting.

You may set either position for plain knitting

(3) Partial Knitting Lever

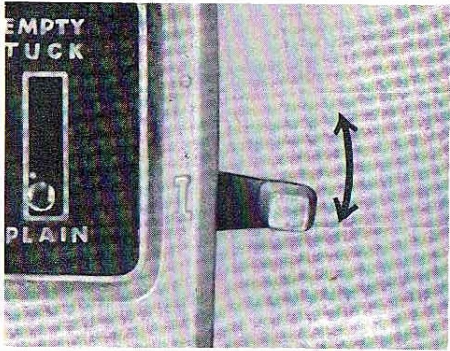

Set the partial knitting lever at "I" position for partial knitting or tuck stitch. Set it at "·" position for other knitting except the above two.

(4) Stitch Adjustor Dial

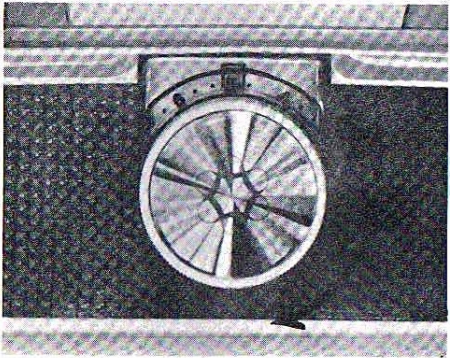

The dial is indicated with 0 to 10. The larger the indication on dial, the wider the size of stitch. Adjust the number of indication as below mentioned, according to the thickness of the yarn.

Pattern Yarn used	One-Knit One-Purl Rib	Close Rib	Two-Knit Two-Purl Rib	Circular Plain Stitch
Very Fine	—	0 — 1	0 — 1	2 — 3
Medium	1 — 2	3 — 5	4 — 5	4 — 5
Medium Thick	5 — 6	—	6 — 7	6 — 7

Connecting Arm

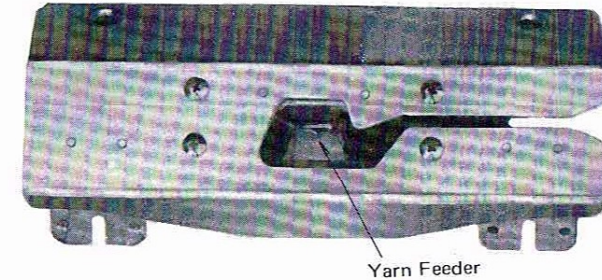

Use this arm when you want to knit together with ribbing carriage and main carriage.

(Note) When you want to operate the main carriage only, push drop lever at both ends of rib knitter and drop down the rib knitter to lower position. Do not forget to remove connecting arm before dropping the rib knitter.

(1) Connection of both Carriages

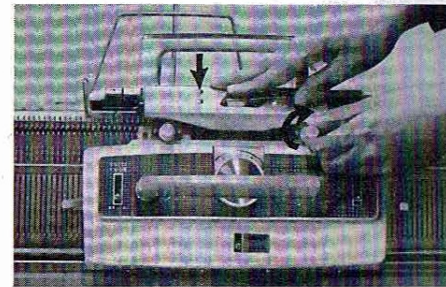

Loosen the fastening knobs of ribbing carriage. Insert the screws of ribbing carriage into the slot of connecting arm while pulling up the both carriages slightly, and tighten the fastening knobs.

(2) Separate the Carriages

Loosen the fastening knobs. Pulling up both carriages and take the ribbing carriage away.

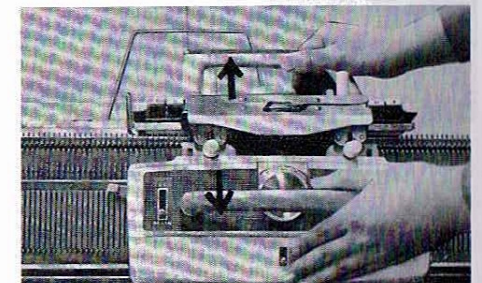

Rib Knitter

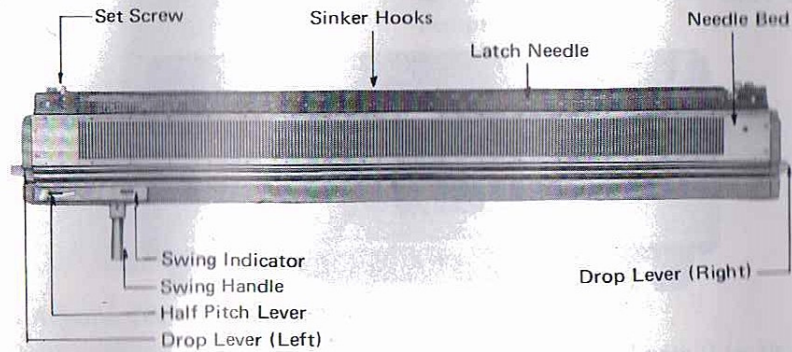

(1) Swing Handle



The swing handle is to be used for swinging the needles sideways to enable swing pattern stitches and rippling waves pattern stitch. The swing indicator can be set at 0 to 10.

(2) Swing Indicator

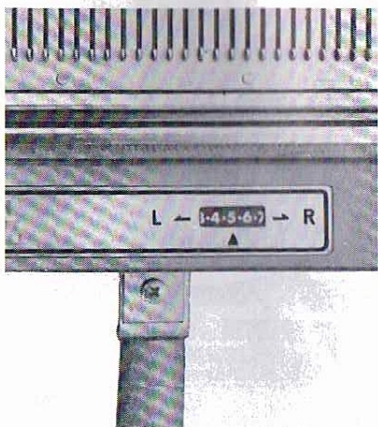

The swing indicator is usually set at 5 or 5.5. And the indicator shows the swinging position of rib knitter when the swing handle is used for swinging the rib knitter sideways.

(3) Half Pitch Lever

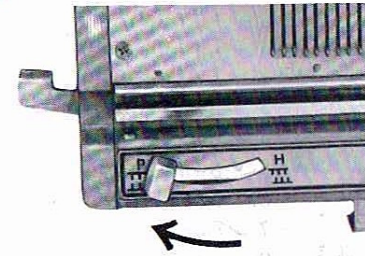

Half pitch lever has "P" and "H" position.

When the lever is set at "P" position, main knitter needles and ribbing needles directly opposite to each other. And this position is used for one-knit one-purl rib knitting.

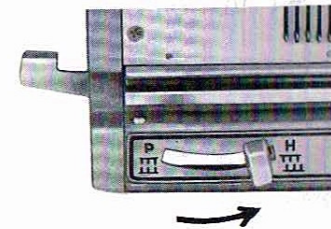

When the lever is set at "H" position, ribbing needles are halfway between two main knitter needles.

This position is used for two-knit two-purl rib, close rib, circular plain stitch, etc..

(4) Drop Lever



Rib knitter can be positioned at three steps, upper, middle and lower.

Upper Position:

Upper position is to be ready for rib knitting.

Middle Position:

Middle position is used for picking up dropped stitches.

(One step drop)

Lower Position:

Lower position is used for regular knitting of main knitter, while the rib knitter is connected with main knitter.

(Two step drop)

When you drop the rib knitter, push down the drop levers on both sides of rib knitter at the same time.

On the other hand, when you want to reset the rib knitter in the operative position, lift up the rib knitter by your hands as high as it will go, and the rib knitter automatically set at its original position.

2. ACCESSORIES NAME AND HOW TO USE ACCESSORIES

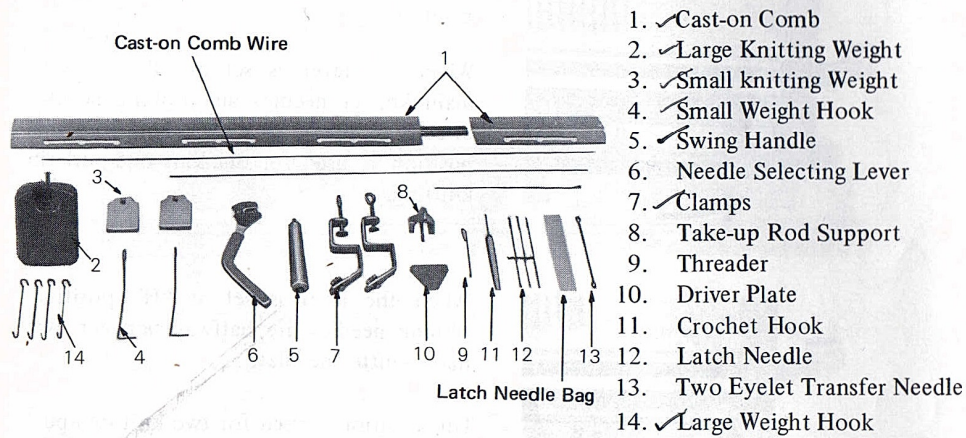

(1) Cast-on Comb

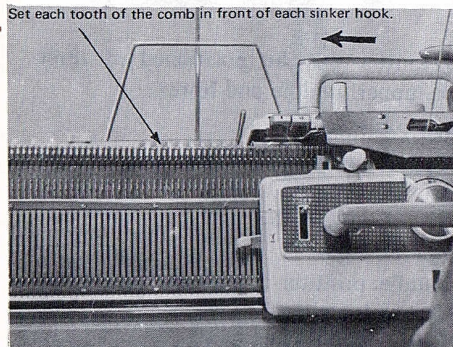

This is to be used when knitting the first row, in either of the following ways.

Method 1

Hold the comb in the left hand and insert it between the main knitter and rib knitter bed as high as the sinker hooks. Each tooth of the comb must line up in front of each sinker hook. Slide the carriage to the left.

The needles of rib knitter should remain in A position and are not knitted.

Method 2

Remove the wire from the comb and insert the comb between main knitter and rib knitter beds from underneath. Ensure that the teeth of the comb pass through the first knitted row of the casting-on edge which has been previously knitted.

Reinsert the wire into the comb.

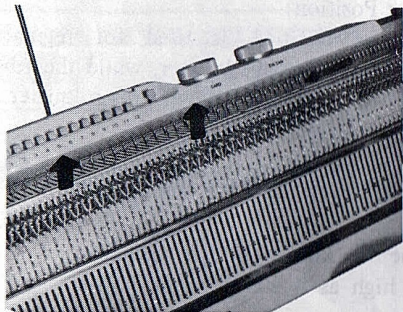

The cast-on comb may be used in the following ways depending on the number of stitch for your knitting.

- Cast-on Comb (Small) Less than 50 stitches
- Cast-on Comb (Large) More than 51 to less than 150 stitches
- Cast-on Comb (Combined with More than 151 to less than 200 stitches
small and large)

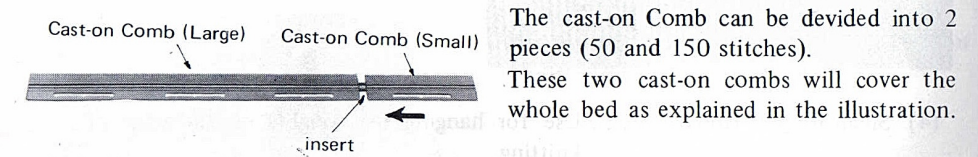

The cast-on Comb can be divided into 2 pieces (50 and 150 stitches). These two cast-on combs will cover the whole bed as explained in the illustration.

(2) Large Knitting weights

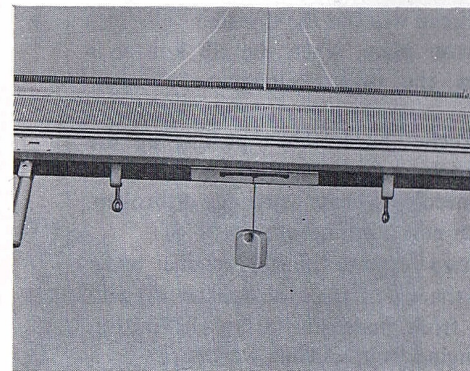

Using the knitting weights, you can get better conditions for your smooth knitting. Hang the knitting weights on the cast-on comb.

Adjust the knitting weights used, depending on the knitting pattern and the width of knitting.

Number of Stitches	Less 50	51 - 150	151 - 200
Number of Weights Used	1	3	4

(3) Small Knitting Weights

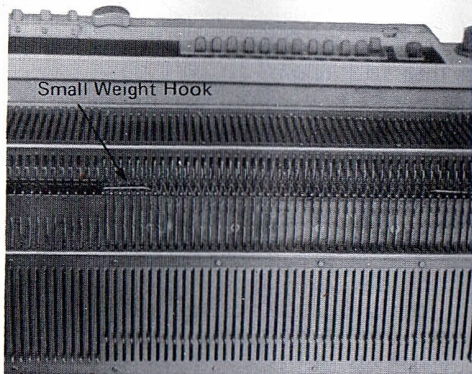

Use for getting better knitting conditions of edge stitches. Hang the small knitting weights at the edge of knitting, using the hooks with weights. Reset the knitting weights hung on the edge of the knitting, every 20 to 30 rows of knitting.

- (4) Small Weights Hook Use for hanging the weights on the edge of knitting.
- (5) Swing Handle Use the swing handle, when you want to swing the rib knitter to the right or left.
- (6) Needle selecting lever Use the needle selecting lever, when you select the needles of main knitter.
- (7) Clamps. Use the clamps, when you set the main knitter on a table.
- (8) Take-Up Rod Support Use the take-up rod support to mount the take-up to the main knitter.
- (9) Threader. Use the threader, when you thread the machine. You may thread without the threader.
- (10) Driver Plate Use the driver plate, when the rib knitter is installed to the main knitter, as a screw driver.
- (11) Crochet Hook. Use the crochet hook, when picking up the dropped stitch.
- (12) Latch Needle When the needle is bent, worn out or broken, replace with new latch needle.
- (13) Two Eyelet Transfer Needle. Use the two eyelet transfer needle when converting the stitch from rib knitter to main knitter or from main knitter to rib knitter.
- (14) Large Weight Hook. Use for hanging large knitting weights.

3. HOW TO SET RIB KNITTER TO MAIN KNITTER

Fit the clamps provided in the accessory box of Rib Knitter to the underside of the main knitter, instead of main knitter clamps which is used only for normal knitting work.

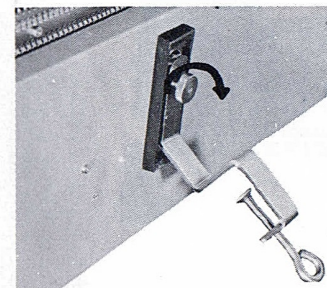

Then tighten the screw to lock the main knitter on the knitting table.

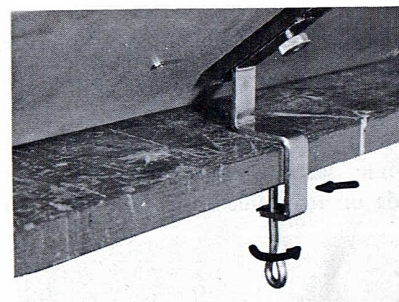

Fit an angle type needle selecting lever to the underneath of the main knitter.

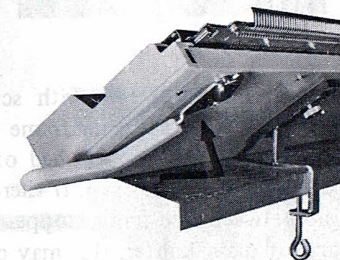

Set rib knitter's take-up rod support on the main knitter.

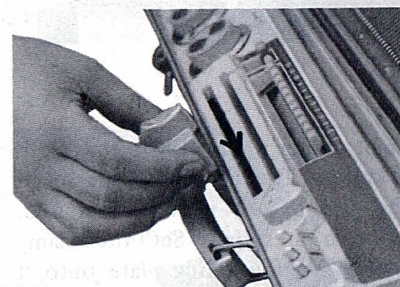

Insert the take-up rod, curved part downward into the hole on the take-up rod support.

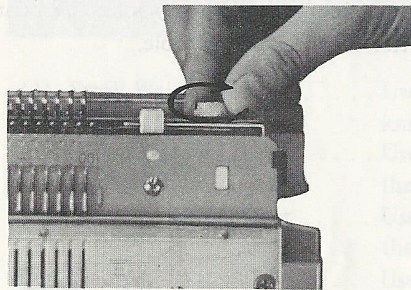
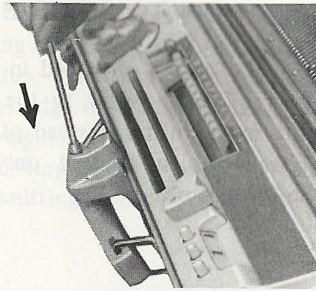

Install the rib knitter to the main knitter

First, take away the set screws from the right and left side frames. Install side frame (Right) to main knitter. While securing right side, place left side on to needle bed of main knitter.

Fasten the set screw with screw driver plate, securing the side frame stopper to the front of the needle bed of the main knitter without any gap. If there is a slight gap between side frame stopper and needle bed of main knitter, this may cause dropped stitches and alter the stitch gauge.

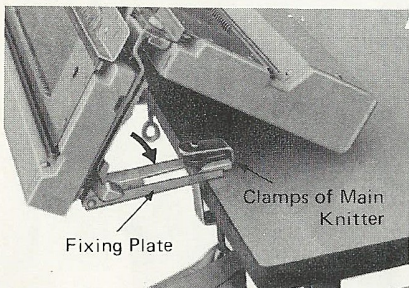
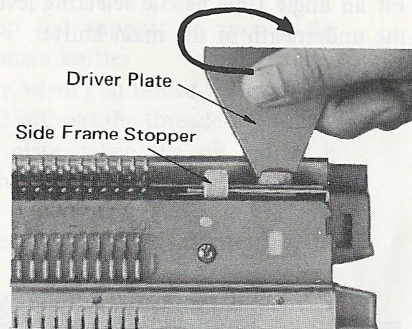

Set right fixing plate with the clamps of main knitter. The fixing plate is located on the side of the machine and folded under with a spring. Set the clamps, pushing down the fixing plate onto the knitting table.

Install side frame (Left) to main knitter in the same way. At this stage, do not tighten screw

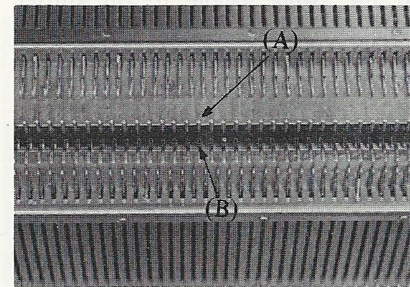
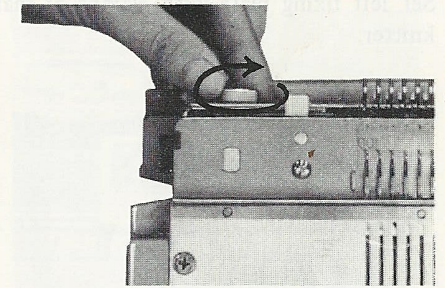

Set the half pitch lever to "P" position. Check whether the sinker hooks on the main knitter "A" are exactly opposite the hooks on the rib knitter "B". And furthermore confirm it again by swinging swing handle for 2 or 3 pitches.

If the rib knitter sinkers are not opposite the main knitter sinkers, make adjustment by loosening the set screw of left side and sliding the rib knitter to left or right.

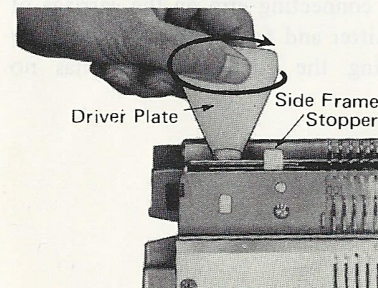
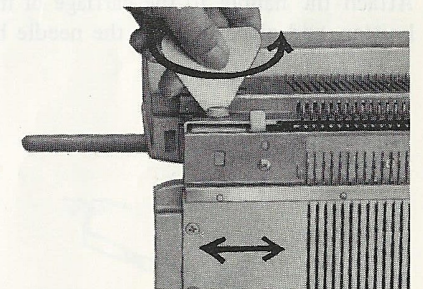

After all adjustments are completed, tighten the screws of both sides securely, and recheck both side frame stoppers may be close to the front edge of needle bed of main knitter.

Set left fixing plate with clamps of main knitter.

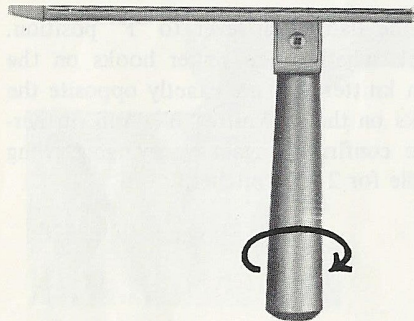
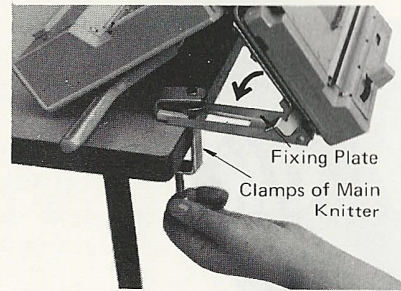

Attach the swing handle to rib knitter fastening securely, while checking so the swing handle attached to the machine has no play.

Attach the handle to the carriage of main knitter, and place it on to the needle bed.

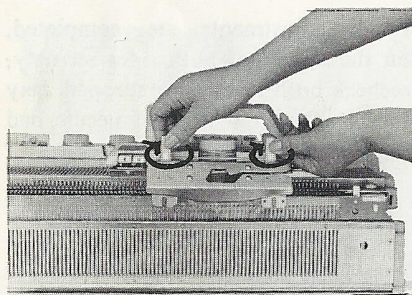
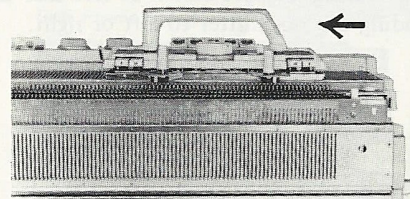

Set the connecting arm on the carriage of main knitter and fasten the screw securely confirming the connecting arm has no play.

Attach the handle to the carriage of rib knitter and place it on to rib knitter.

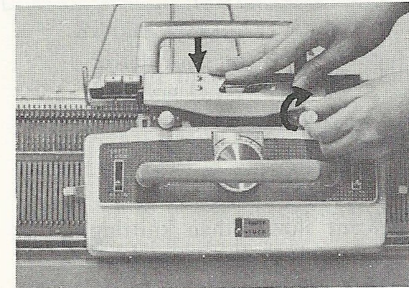
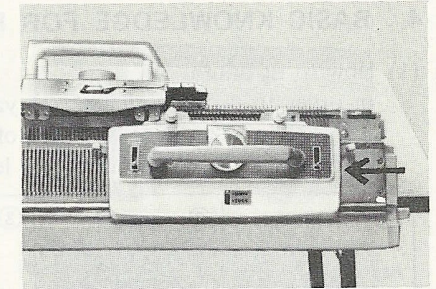

Fix the connecting arm to ribbing carriage by tightening the fastening knobs, while pushing the connecting arm downwards slightly to prevent the floating of ribbing carriage.

Mount the paraffin on the take-up, and set the adjustor dial at (-) position. Use the paraffins when two kinds of yarn may be used through take-up for your knitting.
Note: Please refer to the explanation in this manual, how to thread to the take-up.

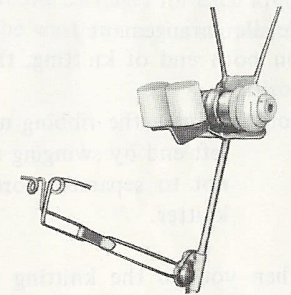

With above steps, all preparations for your knitting using rib knitter are completed.

4. BASIC KNOWLEDGE FOR RIB KNITTER

(1) How to tie a knot

In order to make small knot of yarn, make a knot of yarn as the following ways in the steps 1 to 5. A tip of yarn should be less than 5 mm from the knot, and if it is longer than that length, cut the tip of the yarn.

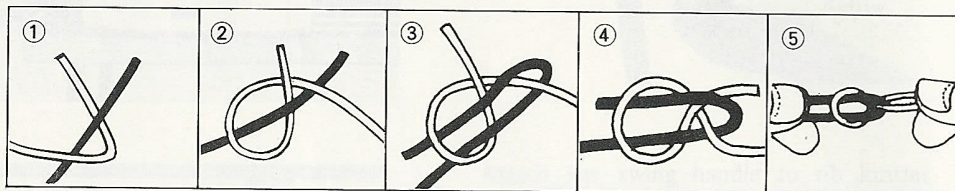

(2) Adjustment of Take-Up

Set the adjustor dial of take-up at (-) position, when it is used for rib knitter

Note: Use the paraffin always regardless of the yarn size.

(3) Knitting Speed

The knitting speed should become about 30 percent slower than knitting with main knitter only.

(Operate the carriage with 50 to 70 cm knitting speed per second.)

When you start knitting, you must operate the carriage slowly.

(4) Needle Arrangement

On both end of knitting, the main knitter needles must always be in work position.

Note: In case the ribbing needle becomes to be in work position at right or left end by swinging the rib knitter, arrange the relative ribbing needle not to separate more than one pitch from the edge needle of main knitter.

(5) When you do the knitting with double knitting yarn, use the needles one after the other.

(6) Do not swing the rib knitter, when the needles of main knitter and rib knitter intersect each other. If rib knitter is swung, the needles may break or bend.

5. HOW TO KNIT

(1) Casting-on and Finished Cast-on

In this case, the use of medium yarn is advised.

Set the carriages for starting to knit as shown in the figures.

Main Carriage

Stitch Adjustor Dial . . . Set at "5"
Set for plain knitting.

Ribbing Carriage

Stitch Adjustor Dial . . . Set at "5"
Knitting Lever

. Set at PLAIN at
both sides

Tuck and Empty Lever

. Set at EMPTY

Partial Knitting Lever

. Set at "·" at both
sides

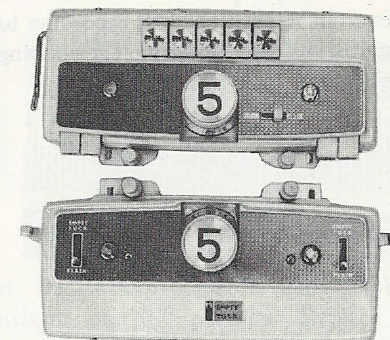

Move out the carriages for each knitter and thread the waste yarn for starting to knit.

Hook the end of yarn to the holder of fixing plate.

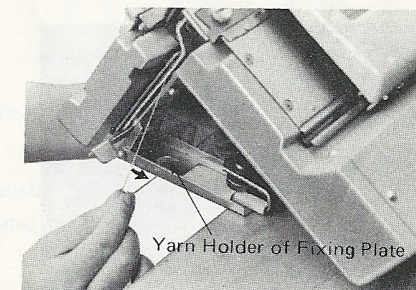

Move the required number of main needles from A position to B according to the width of the knitting. The ribbing needles remain in A position.

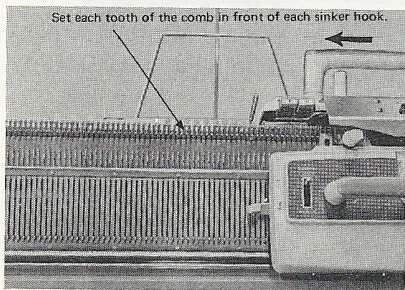
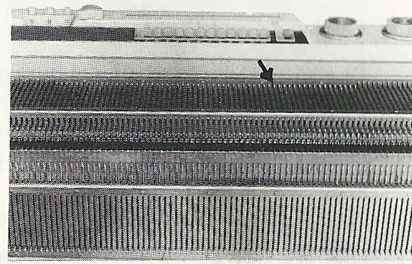

Hold the comb in the left hand and insert it between the main and rib knitter beds as high as the sinker hooks. Each tooth of the comb must line up in front of each sinker hook. The hung cast-on comb must be well balanced.

Release the yarn from the holder of fixing plate

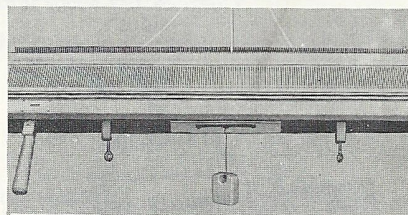

Fig. a

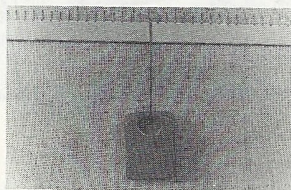
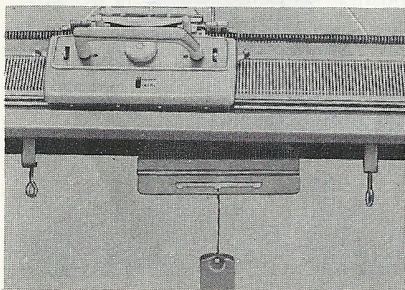

Fig. b

Slide the carriage and do plain knitting for a several rows. Always place the carriages at right side of the machines. By the above steps, you completed the casting-on.



Finished Cast-on

Set the half pitch lever at "H" position. Move the required numbers of ribbing needles from "A" position to "B". At each end, the last needles should be main knitter needles.

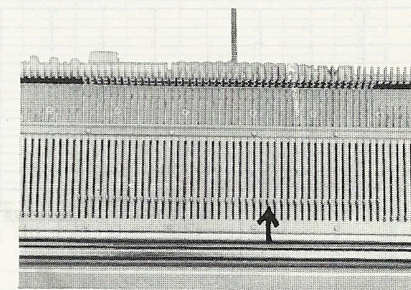

Set the stitch adjustor dial of both carriages at "0" position. Replace the waste yarn with base yarn, and slide the carriages from right to left and knit one row.

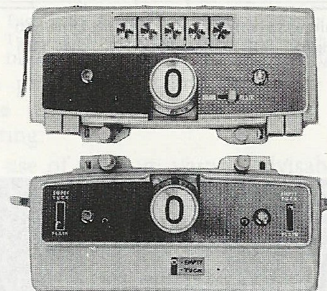

Push right EMPTY button of main carriage in, and set the ribbing carriage as follows;
Knitting Lever . . . PLAIN at right
EMPTY at left
Tuck and Empty Lever
. . . EMPTY

Slide the carriages from left to right and knit one row. Set the stitch adjustor dial of both carriages at "5" position. Slide the carriages both ways and knit 3 rows.

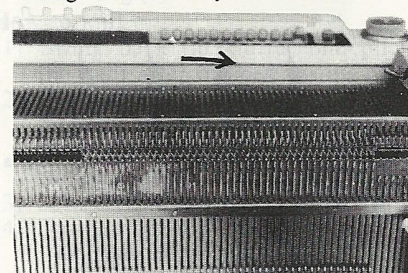
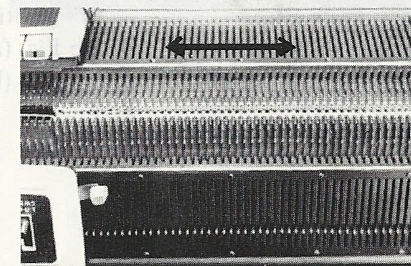

Set the main carriage for plain knitting. Set the left knitting lever of ribbing carriage at PLAIN. Slide the carriages and knit one row.

By the above steps, you have completed and learned the casting-on and finished cast-on.

Hereafter, following the kind of rib knitting, transfer the bound off stitch (by finished cast-on) onto the needles to be knitted and proceed with various kinds of rib knitting.

(2) One-Knit One-Purl Rib

																		"	"	"	"	"										"	→	10
																			"	"	"	"	"									"	←	9
																			"	"	"	"	"									"	→	8
																			"	"	"	"	"									"	←	7
																			"	"	"	"	"									"	→	6
																			"	"	"	"	"									"	←	5
																			"	"	"	"	"									"	→	4
																			"	"	"	"	"									"	←	3
																			"	"	"	"	"									"	→	2
																			"	"	"	"	"									"	←	1
																			●	P	T	P	●									○	←	1
I	II	A	B	C	D	E	II	I	F	G	H	I	J	K	L	M	N																	

A: Tuck B: Empty C: Plain D: Empty E: Tuck F: Partial Knitting Lever(left) G: Knitting Lever(left)
 H: Tuck and Empty Lever I: Knitting Lever(right) J: Partial Knitting Lever(right) K: Colour Yarn L: Base Yarn
 M: Direction of Carriage N: Number of Knitting Row

The use of medium yarn is advisable.

Stitch Adjustor Dial

Main Carriage 2
 Ribbing Carriage 2

Half Pitch Lever "P" position

Needle Arrangement See Fig. (a)

Swing Indicator See Fig. (b)

Note: Use paraffin for getting better conditions to knit.

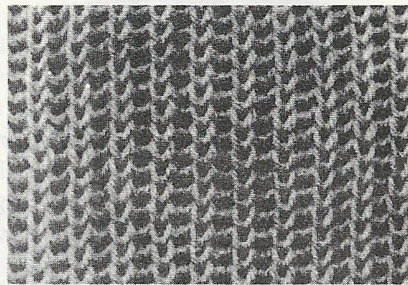

How to knit

(1) Set the main carriage for plain knitting.

(2) Set the ribbing carriage as follows.

Knitting Lever . . . PLAIN at both sides
 Partial Knitting . . . "." at both side Lever

(3) Slide the carriages from right to left to knit one row.

(4) Slide the carriage from left to right to knit one row.

By repeating 3-4, you can make One-Knit One-Purl Rib.



Fig. a

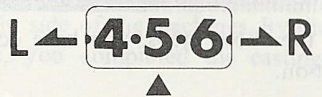

Fig. b

(3) Two-Knit Two-Purl Rib

																			"	"	"	"	"									"	→	10
																			"	"	"	"	"									"	←	9
																			"	"	"	"	"									"	→	8
																			"	"	"	"	"									"	←	7
																			"	"	"	"	"									"	→	6
																			"	"	"	"	"									"	←	5
																			"	"	"	"	"									"	→	4
																			"	"	"	"	"									"	←	3
																			"	"	"	"	"									"	→	2
																			"	"	"	"	"									"	←	1
																			●	P	T	P	●									○	←	1
I	II	A	B	C	D	E	II	I	F	G	H	I	J	K	L	M	N																	

A: Tuck B: Empty C: Plain D: Empty E: Tuck F: Partial Knitting Lever(left) G: Knitting Lever(left)
 H: Tuck and Empty Lever I: Knitting Lever(right) J: Partial Knitting Lever(right) K: Colour Yarn L: Base Yarn
 M: Direction of Carriage N: Number of Knitting Row

Two plain stitches and two purl stitches come out lengthwise alternately in this knitting.

The use of medium yarn is advisable.

Stitch Adjustor Dial

Main Carriage 5
 Ribbing Carriage 5

Half Pitch Lever "H" position

Needle Arrangement See Fig. (a)

At each end, the last needles should be main knitter needles.

Swing Indicator See Fig. (b)

Note: Use paraffin to knit.

* Casting-on for Two-Knit Two-Purl Rib.

Swing the rib knitter one pitch to the left using Swing Handle and then raise one needle on the right side to B position. Fig.(c)

How to knit

(1) Swing back rib knitter one pitch to the right after finished casting-on.

(2) Transfer the right end stitch on rib knitter to the right end needle on main knitter and push back emptied needle to A position.

(3) Set the main carriage for plain knitting.

(4) Set the ribbing carriage as follows.
 Knitting Lever . . . PLAIN at both sides
 Partial Knitting . . . "." at both sides

(5) Slide the carriages from right to left to knit one row.

(6) Slide the carriages from left to right to knit one row.

By repeating 5-6 you can make Two-Knit Two-Purl Rib.

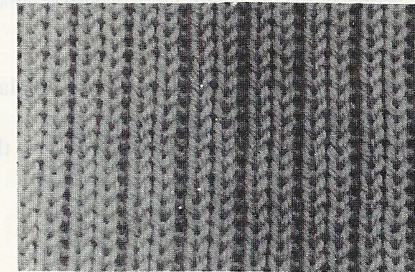

Fig. a

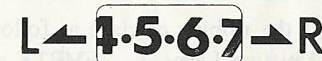
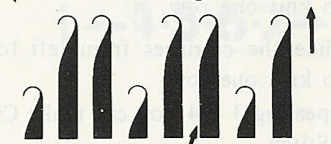
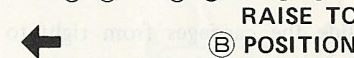
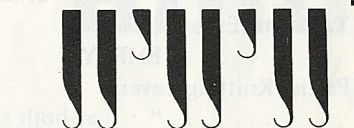

Fig. b



RIGHT END OF WORKING NEEDLE Fig. c

(4) Circular Plain Stitch

									"	"	"	"	"	"					"	"	→	10
									"	"	"	"	"	"					"	"	←	9
									"	"	"	"	"	"					"	"	←	8
									"	"	"	"	"	"					"	"	←	7
									"	"	"	"	"	"					"	"	→	6
									"	"	"	"	"	"					"	"	←	5
									"	"	"	"	"	"					"	"	→	4
									"	"	"	"	"	"					"	"	←	3
									"	"	"	"	"	"					"	"	→	2
									"	"	"	"	"	"					"	"	←	1
									○													
I	II	A	B	C	D	E	II	I	F	G	H	I	J	K	L	M	N					

A: Tuck B: Empty C: Plain D: Empty E: Tuck F: Partial Knitting Lever(left) G: Knitting Lever(left)
H: Tuck and Empty Lever I: Knitting Lever(right) J: Partial Knitting Lever(right) K: Colour Yarn L: Base Yarn
M: Direction of Carriage N: Number of Knitting Row

This is seamless circular knitting in a plain stitch.

The size of the circle depends on the number of needles used.

The use of medium yarn is advisable.

Stitch Adjustor Dial

Main Carriage 5

Ribbing Carriage 5

Half Pitch Lever "H" position

Needle Arrangement See Fig. (a)

Swing Indicator See Fig. (b)

Note: Use paraffin.

How to knit

(1) Push the left EMPTY button of main Carriage in.

(2) Set the ribbing carriage as follows.
Knitting Lever . . . EMPTY at right
PLAIN at left

Tuck and Empty Lever EMPTY

Partial Knitting Lever "•" at both sides

(3) Slide the carriages from right to left to knit one row.

(4) Slide the carriages from left to right to knit one row.

By repeating 3 - 4 you can make Circular Plain Stitch.



Fig. a

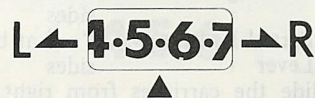

Fig. b

(5) Close Rib

									"	"	"	"	"	"					"	"	→	10
									"	"	"	"	"	"					"	"	←	9
									"	"	"	"	"	"					"	"	←	8
									"	"	"	"	"	"					"	"	←	7
									"	"	"	"	"	"					"	"	→	6
									"	"	"	"	"	"					"	"	←	5
									"	"	"	"	"	"					"	"	→	4
									"	"	"	"	"	"					"	"	←	3
									"	"	"	"	"	"					"	"	→	2
									"	"	"	"	"	"					"	"	←	1
									○													
I	II	A	B	C	D	E	II	I	F	G	H	I	J	K	L	M	N					

A: Tuck B: Empty C: Plain D: Empty E: Tuck F: Partial Knitting Lever(left) G: Knitting Lever(left)
H: Tuck and Empty Lever I: Knitting Lever(right) J: Partial Knitting Lever(right) K: Colour Yarn L: Base Yarn
M: Direction of Carriage N: Number of Knitting Row

The method of this knitting is the same as for one-knit one-purl rib except that every main and ribbing needles will be working. This is especially suitable for fine yarn.

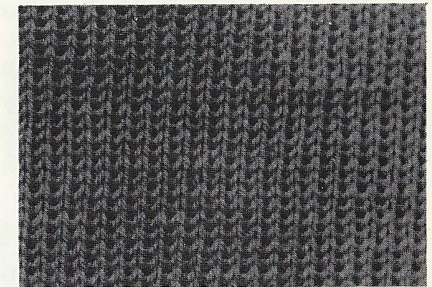

Stitch Adjustor Dial

Main Carriage 1

Ribbing Carriage 1

Half Pitch Lever "H" position

Needle Arrangement See Fig. (a)

Swing Indicator See Fig. (b)

Note: Use paraffin.

How to knit

(1) Set the main carriage for plain knitting.

(2) Set ribbing carriage as follows.
Knitting Lever . . . PLAIN at both sides

Partial Knitting Lever "•" at both sides

(3) Slide the carriages from right to left to knit one row.

(4) Slide the carriages from left to right to knit one row.

By repeating 3 - 4 you can make Close Rib.



Fig. a

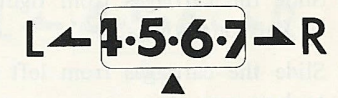
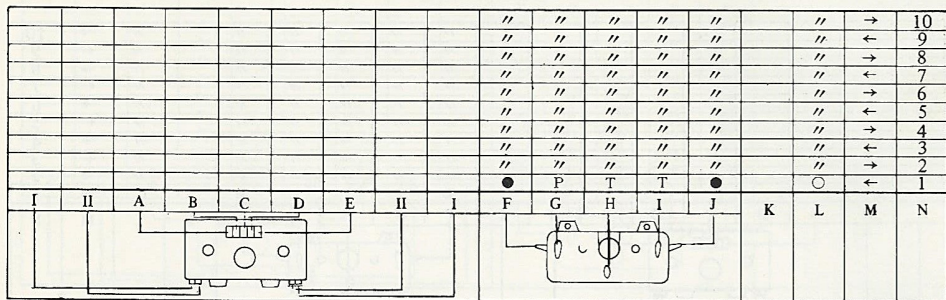

Fig. b

(6) Single Fisherman's Rib



A: Tuck B: Empty C: Plain D: Empty E: Tuck F: Partial Knitting Lever(left) G: Knitting Lever(left)
 H: Tuck and Empty Lever I: Knitting Lever(right) J: Partial Knitting Lever(right) K: Colour Yarn L: Base Yarn
 M: Direction of Carriage N: Number of Knitting Row

This is knitted by changing one side of the one knit one-purl rib or the close rib into a tuck pattern stitch.

Single Fisherman's Rib is best knitted using a medium yarn, and a very fine yarn when using close rib setting.

Stitch Adjustor Dial

- Main Carriage 3
- Ribbing Carriage 2
- Half Pitch Lever "P" position
- Needle Arrangement See Fig. (a)
- Swing Indicator See Fig. (b)

Note: Use paraffin.

How to knit

- (1) Set the main carriage for plain knitting.
- (2) Set the ribbing carriage as follows.
 Knitting Lever . . . TUCK at right
 PLAIN at left
 Tuck and Empty Lever TUCK
 Partial Knitting Lever "●" at both sides
- (3) Slide the carriages from right to left to knit one row.
- (4) Slide the carriages from left to right to knit one row.

By repeating 3 - 4 you can make Single Fisherman's Rib.

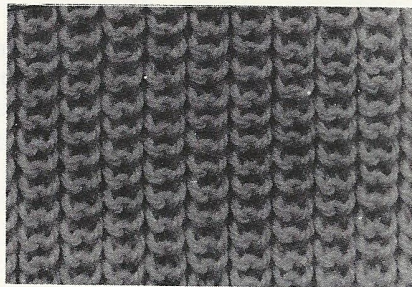

Fig. a

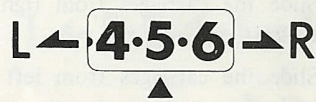
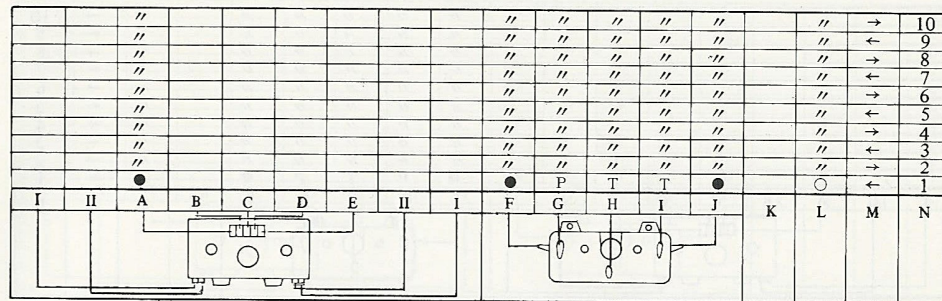

Fig. b

(7) Double Fisherman's Rib:



A: Tuck B: Empty C: Plain D: Empty E: Tuck F: Partial Knitting Lever(left) G: Knitting Lever(left)
 H: Tuck and Empty Lever I: Knitting Lever(right) J: Partial Knitting Lever(right) K: Colour Yarn L: Base Yarn
 M: Direction of Carriage N: Number of Knitting Row

This can be made by knitting a tuck pattern stitch on both sides of one-knit one-purl rib or close rib.

Suitable for fine or medium yarn.

Stitch Adjustor dial

- Main Carriage 3
- Ribbing Carriage 3
- Half Pitch Lever "P" position
- Needle Arrangement See Fig. (a)
- Swing Indicator See Fig. (b)

Note: Use paraffin.

How to knit

- (1) Push the left TUCK button of main carriage in.
- (2) Set the ribbing carriage as follows.
 Knitting Lever TUCK at right
 PLAIN at left
 Tuck and Empty Lever . . . TUCK
 Partial Knitting Lever "●" at both sides
- (3) Slide the carriages from right to left to knit one row.
- (4) Slide the carriages from left to right to knit one row.

By repeating 3 - 4 you can make Double Fisherman's Rib.

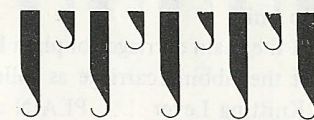
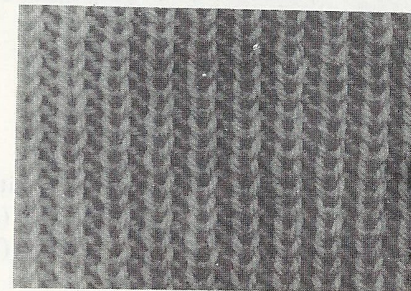

Fig. a

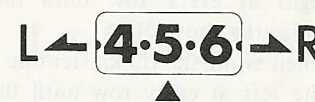
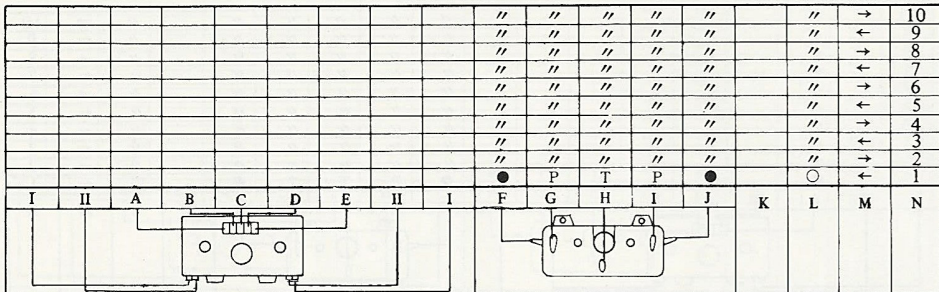

Fig. b

(8) Swing Pattern Stitch



A: Tuck B: Empty C: Plain D: Empty E: Tuck F: Partial Knitting Lever(left) G: Knitting Lever(left)
 H: Tuck and Empty Lever I: Knitting Lever(right) J: Partial Knitting Lever(right) K: Colour Yarn L: Base Yarn
 M: Direction of Carriage N: Number of Knitting Row

This can be obtained by swinging the rib knitter pitch by pitch and according to the needle selection

Suitable for medium yarn.

Stitch Adjustor Dial

Main Carriage 5
 Ribbing Carriage 3

Half Pitch Lever "H" position
 Needle arrangement See Fig. (a)
 Swing Indicator See Fig. (b)

Note: Use paraffin.

How to knit

- Set the main carriage for plain knitting.
- Set the ribbing carriage as follows.

Knitting Lever . . . PLAIN at both sides

Partial Knitting Lever "•" at both sides

- Slide the carriages from right to left to knit one row.
- Swing the rib knitter one pitch to the right by using the swing handle.
- Swing the rib knitter one pitch to the right at every row until the swing indicator shows 10.5.
- Then swing the rib knitter one pitch to the left at every row until the swing indicator shows 0.5.

By repeating 3 – 6 you can make Swing Pattern Stitch.

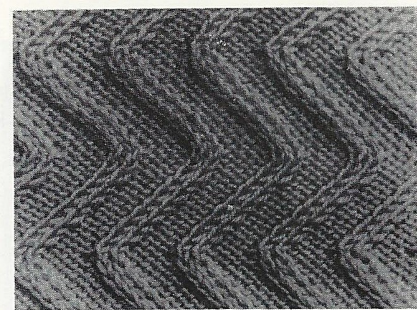

Fig. a

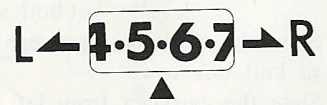
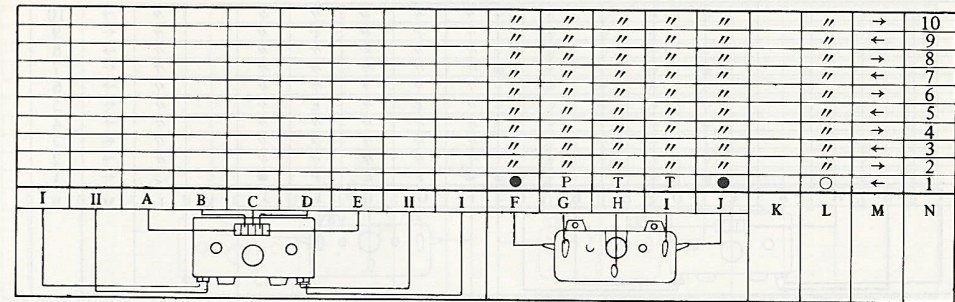

Fig. b

(9) Rippling Waves Pattern Stitches



A: Tuck B: Empty C: Plain D: Empty E: Tuck F: Partial Knitting Lever(left) G: Knitting Lever(left)
 H: Tuck and Empty Lever I: Knitting Lever(right) J: Partial Knitting Lever(right) K: Colour Yarn L: Base Yarn
 M: Direction of Carriage N: Number of Knitting Row

This is made with single fisherman's rib and swing pattern stitch.

Suitable for medium yarn.

Stitch Adjustor Dial

Main Carriage . ; 3
 Ribbing Carriage 2

Half Pitch Lever "H" position
 Needle Arrangement See Fig. (a)
 Swing Indicator See Fig. (b)

Note: Use paraffin.



How to knit

- Set the main carriage for plain knitting.
- Set the ribbing carriage as follows.

Knitting Lever . . . TUCK at right.
 PLAIN at left

Tuck and Empty Lever TUCK

Partial Knitting Lever "•" at both sides

- Slide the carriages from right to left to knit one row.
- Slide the carriages from left to right to knit one row.
- Swing the rib knitter one pitch to the right using the swing handle.
- Repeat the steps (3) and (4).
- Swing the rib knitter one pitch to the left.

Repeat the above steps from (3) to (7).



Fig. a

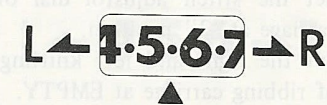

Fig. b

(10) Pin Tuck Pattern Stitch

								"	"	"	"	"					"	→	10
								"	P	"	P	"					"	←	9
								"	"	"	"	"					"	←	8
								"	"	"	"	"					"	←	7
								"	"	"	"	"					"	←	6
								"	E	"	E	"					"	←	5
								"	"	"	"	"					"	←	4
								"	"	"	"	"					"	←	3
								"	"	"	"	"					"	→	2
								•	P	E	P	•				○	←	1	
I	II	A	B	C	D	E	II	I	F	G	H	I	J	K	L	M	N		

A: Tuck B: Empty C: Plain D: Empty E: Tuck F: Partial Knitting Lever(left) G: Knitting Lever(left)
 H: Tuck and Empty Lever I: Knitting Lever(right) J: Partial Knitting Lever(right) K: Colour Yarn L: Base Yarn
 M: Direction of Carriage N: Number of Knitting Row

Suitable for very fine yarn.

Half Pitch Lever "H" position

Needle Arrangement See Fig. (a)

Swing Indicator See Fig. (b)

Note: Use paraffin.

How to knit

(1) Set the stitch adjuster dial of main carriage at "1" position and set the carriage for plain knitting.

(2) Set the stitch adjuster dial of ribbing carriage at "1" position and set the carriage as follows.

Knitting Lever . . PLAIN at both sides

Tuck and Empty Lever EMPTY

Partial Knitting Lever "•" at both sides

(3) Slide the carriages from right to left to knit one row.

(4) Slide the carriages from left to right to knit one row.

(5) Repeat the steps (3) and (4), and knit four rows;

(6) Set the stitch adjuster dial of main carriage at "2" position.

(7) Set the right and left knitting levers of ribbing carriage at EMPTY.

(8) Repeat the steps from (3) to (5), and knit four rows.

Repeat the above steps from (1) to (8).

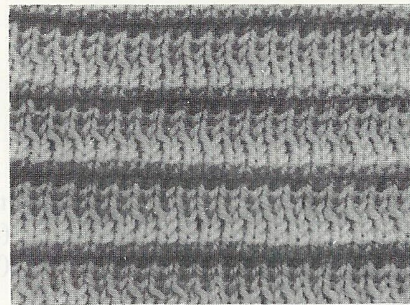

Fig. a

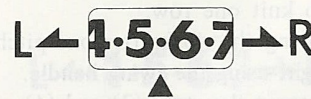

Fig. b

(11) Tuck Stitch

								"	"	"	"	"					"	→	10
								I	"	"	"	"	I				"	←	9
								"	"	"	"	"	"				"	←	8
								•	"	"	"	"	•				"	←	7
								"	"	"	"	"	"				"	←	6
								"	"	"	"	"	"				"	←	5
								"	"	"	"	"	"				"	←	4
								"	"	"	"	"	"				"	←	3
								"	"	"	"	"	"				"	→	2
								•	P	T	P	•				○	←	1	
I	II	A	B	C	D	E	II	I	F	G	H	I	J	K	L	M	N		

A: Tuck B: Empty C: Plain D: Empty E: Tuck F: Partial Knitting Lever(left) G: Knitting Lever(left)
 H: Tuck and Empty Lever I: Knitting Lever(right) J: Partial Knitting Lever(right) K: Colour Yarn L: Base Yarn
 M: Direction of Carriage N: Number of Knitting Row

The use of medium yarn is advisable.

Stitch Adjustor Dial 5

Main Carriage 5

Ribbing Carriage 3

Half Pitch Lever "P" position

Needle Arrangement See Fig. (a)

Swing Indicator See Fig. (b)

Note: Use paraffin.

How to knit

(1) Set main carriage for plain knitting.

(2) Set ribbing carriage as follows.

Knitting Lever . . PLAIN at both sides

Partial Knitting Lever "•" at both sides

(3) Slide the carriages from right to left and knit one row.

(4) Slide the carriages from left to right and knit one row.

(5) Set the right and left partial knitting levers of ribbing carriage at "I" position.

(6) Push up the all ribbing needles while working to "E" position.

(7) Slide the carriages and knit four rows.

Repeat the above steps from (2) to (7).

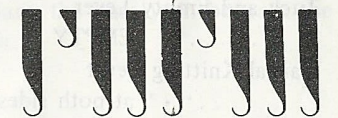
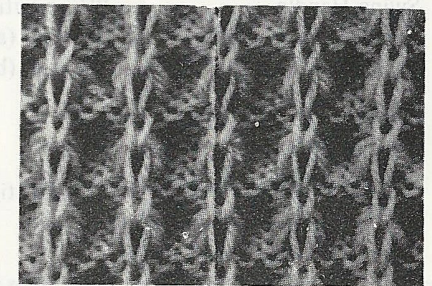

Fig. a

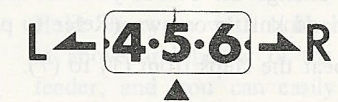

Fig. b

(12) One Side Two Colour Knitting

							"	"	"	"	"	"	"	"	"	"	"	"	→	10
							"	E	"	E	"	○	"	"	"	"	"	←	9	
							"	P	"	P	"	○	"	"	"	"	"	←	8	
							"	"	"	"	"	"	"	"	"	"	"	←	7	
							"	E	"	E	"	○	"	"	"	"	"	←	6	
							"	"	"	"	"	"	"	"	"	"	"	←	5	
							"	P	"	P	"	○	"	"	"	"	"	←	4	
							"	"	"	"	"	"	"	"	"	"	"	←	3	
							"	"	"	"	"	"	"	"	"	"	"	←	2	
							"	E	E	E	"	○	"	"	"	"	"	←	1	
I	H	A	B	C	D	E	H	I	F	G	H	I	J	K	L	M	N			

A: Tuck B: Empty C: Plain D: Empty E: Tuck F: Partial Knitting Lever(left) G: Knitting Lever(right)
 H: Tuck and Empty Lever I: Knitting Lever(right) J: Partial Knitting Lever(right) K: Colour Yarn L: Base Yarn
 M: Direction of Carriage N: Number of Knitting Row

The use of very fine yarn is advisable.
 Stitch Adjustor Dial

Main Carriage 1
 Ribbing Carriage 1

Swing Handle "H" position
 Needle Arrangement See Fig. (a)
 Swing Indicator See Fig. (b)

Note: Use paraffin.

How to knit

- (1) Set the main carriage for plain knitting.
- (2) Set the ribbing carriage as follows

Knitting Lever
 EMPTY at both sides
 Tuck and Empty Lever
 EMPTY
 Partial Knitting Lever
 "•" at both sides

- (3) Slide the carriages and knit two rows with colour yarn.
- (4) Push both EMPTY buttons of main carriage in.
- (5) Set the right and left knitting levers of ribbing carriage at PLAIN.
- (6) Select the needles of main knitter with "1 x 1" by using needle selector lever.
- (7) Change the colour yarn for base yarn and knit two rows. (Refer to page 29)

Repeat the steps from (1) to (7).

Note:
 In the step (6), select the needles which were not selected previously.

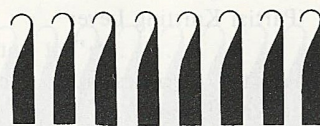

Fig. a

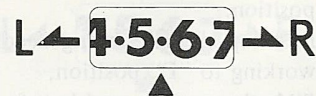
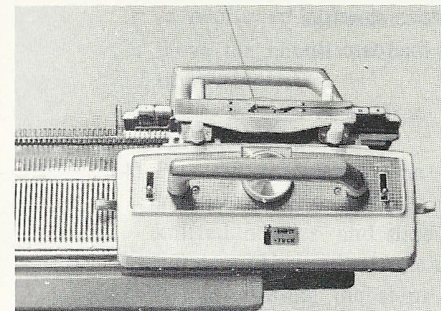
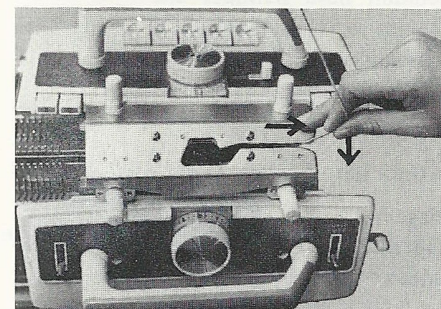

Fig. b

How to change the base yarn to colour yarn



Move out the carriages from each needle bed.



Remove the base yarn from yarn feeder and release from connecting arm.

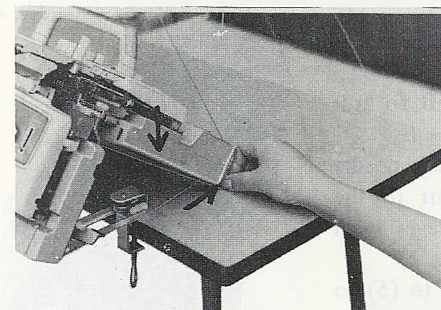

Install both carriages on each knitters and hang the base yarn beneath the main knitter.

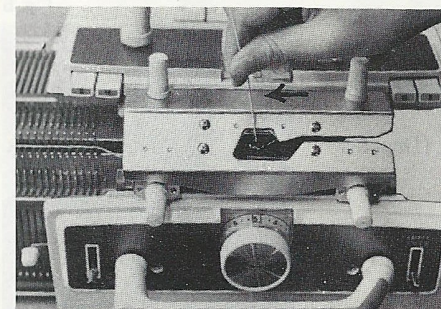

Take the colour yarn out from beneath the main knitter and pass it through yarn feeder.

Note: Hold the yarn with both hands at above and below of the yarn feeder, and you can easily pass the yarn through yarn feeder.

(13) Partial Knitting of Ribbing

This is used for knitting a shoulder line, making darts, neck opening, etc.

There are two methods. (A) one is to decrease the knitting part and (B) another one is to increase the knitting part.

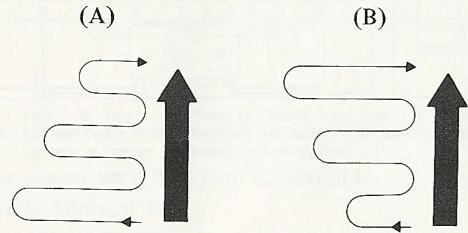

(Decreasing of knitting part) (Increasing of knitting part)

- 1) Partial Knitting of one-knit one-purl rib, two-knit two-purl rib and close rib.

One-knit One-purl Rib is advised in this case.

(A) Decreasing of knitting part

- (1) Push both buttons "I" of main carriage in.
- (2) Set the ribbing carriage as follows. (Fig. a)
Knitting Lever . . . PLAIN at both sides
Partial Knitting Lever
. . . "I" at both sides
- (3) Move the needles not to be knitted from "B" position to "E" position. (Fig. b)
- (4) Slide the carriages from right to left to knit one row.
- (5) Pass the yarn under the stem of the needle in "E" position which is adjacent to the knitted needles, and slide the carriages from left to right and knit one row. (Fig. c)
- (6) After repeating the steps from (3) to (5) to knit the required even number of rows, release both buttons "I" of main carriage and return both partial knitting levers of ribbing carriage to the position of marked "·" and knit one row.

With the above steps the partial knitting (Decreasing) was completed.

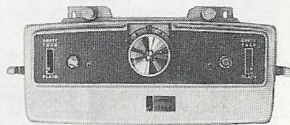

Fig. a

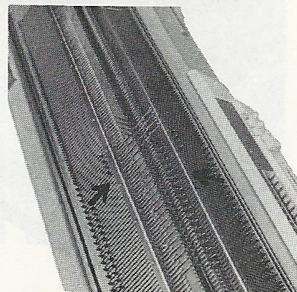

Fig. b

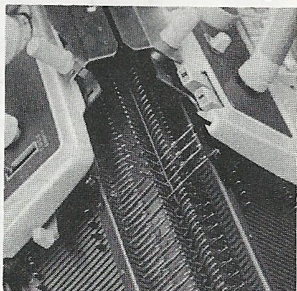

Fig. c

(B) Increasing of knitting part

- (1) The carriages are to be set in the same way as mentioned in the decreasing of knitting part.
- (2) Move the needles to be knitted to "D" position. (Fig. a)
- (3) Slide the carriages from right to left and knit one row.
- (4) Pass the yarn under the stem of the needle in "E" position which is adjacent to the knitted needles, and slide the carriages from left to right and knit one row. (Fig. b)
- (5) After repeating the steps (2) to (4) to knit the required even number of rows, release both buttons "I" of main carriage and return both partial knitting levers of ribbing carriage to the position of marked "·" and knit one row.

With above steps partial knitting (Increasing) was completed.

This is the method of partial knitting of one-knit one-purl rib, two-knit two-purl rib and close rib.

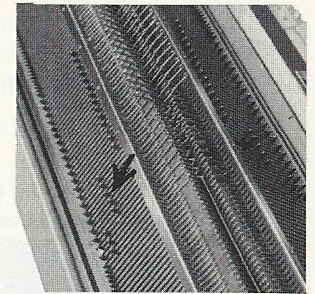

Fig. a

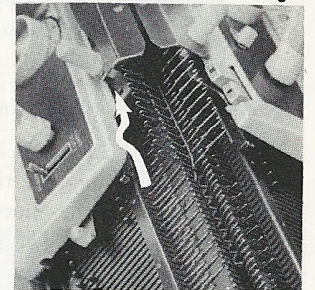

Fig. b

2) Partial Knitting of single fisherman's rib and double fisherman's rib

Single fisherman's rib is advised in this case.

(A) Decreasing of knitting part

- (1) Push the both buttons "I" of main carriage in.
- (2) Set the ribbing carriage as follows. (Fig. a)
Knitting Lever TUCK at right
PLAIN at left
Tuck and Empty Lever . . TUCK
Partial Knitting Lever . . . "I" at both sides
- (3) Following steps are the same way as one-knit one-purl rib.

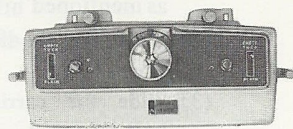

Fig. a

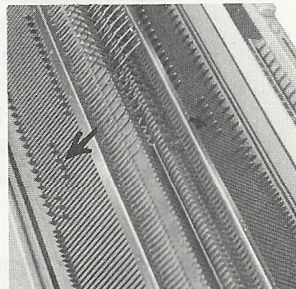

Fig. b

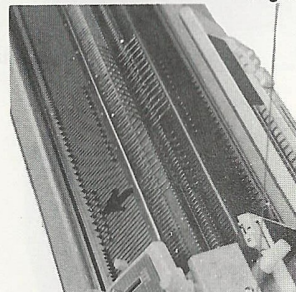

Fig. c

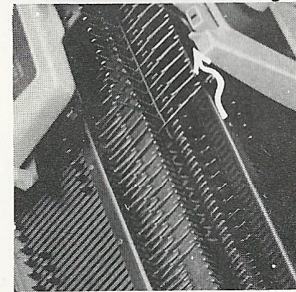

Fig. d

(B) Increasing of knitting part

- (1) Both carriages are to be set in the same way as decreasing rib stitches, explained above.
- (2) Move the needles to be knitted to "D" position. (Fig. b)
- (3) Put the loops on the stem of the needles in "D" position into their hooks by using transfer tool and move them to "B" position. (Fig. c)
- (4) Slide the carriages from right to left and knit one row.
- (5) Pass the yarn under the stem of the needle in "E" position which is adjacent to the knitted needles and slide the carriages from left to right and knit one row. (Fig. d)
- (6) Repeat the steps from (2) to (5) and knit the required number of rows.

This is the method of partial knitting of Single fisherman's rib, Double fisherman's rib, Pin Tuck Stitch and one side two colour knitting.

3) Partial Knitting of Swing Pattern Stitches and Rippling Waves Pattern Stitches

Rippling waves pattern stitches is advised in this case.

(A) Decreasing of knitting part

- (1) Push the both EMPTY buttons of main carriage in.
- (2) Set the ribbing carriage as follows. (Fig. a)
Knitting Lever TUCK at right
PLAIN at left
Tuck and Empty Lever . . TUCK
Partial Knitting Lever . . . "I" at both sides
- (3) Move the needles to be knitted of main knitter to "E" position (Fig. b)
- (4) Move the needles of rib knitter not to be knitted to "E" position. (Fig. b)
- (5) Slide the carriages from right to left and knit one row.
- (6) Pass the yarn under the stem of the needle in "E" position which is adjacent to the knitted needles. (Fig. c)
- (7) Move the needles to be knitted of main knitter to "E" position. (Fig. d)
- (8) Slide the carriages from left to right and knit one row.
- (9) Swing the rib-knitter one pitch to the right by using the swing handle.
- (10) Repeat the steps from (3) to (9) and knit the required number of rows.

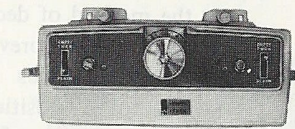

Fig. a

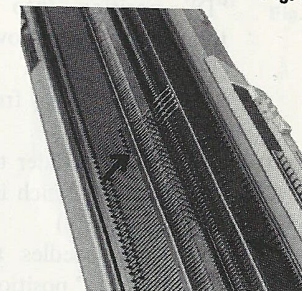

Fig. b

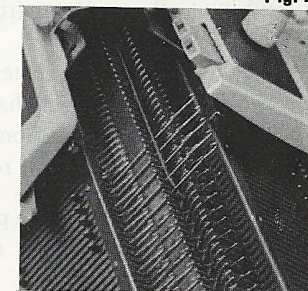

Fig. c

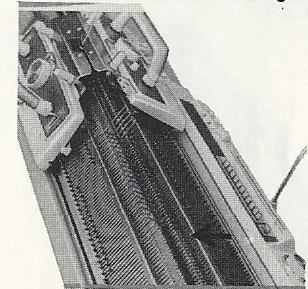

Fig. d

(B) Increasing of knitting part

- (1) Both carriages are to be set in the same way as the method of decreasing of knitting part., explained on the previous page.
- (2) Move the needles of main knitter to be knitted to "E" position.
- (3) Move the needles of rib knitter to be knitted to "D" position. (Fig. a)
- (4) Put the loop on the stem of the needles in "D" position into their hooks by using transfer tool and move them to "B" position. (Fig. b)
- (5) Slide the carriages from right to left and knit one row.
- (6) Pass the yarn under the stem of the needle in "E" position which is adjacent to the knitted needles. (Fig. c)
- (7) Move the needles to be knitted of main knitter to "E" position.
- (8) Slide the carriages from left to right and knit one row.
- (9) Swing the rib knitter one pitch to the right by using the swing handle.
- (10) Repeat the steps from (2) to (9) and knit the required number of rows.

This is the method of partial knitting of swing pattern stitches and rippling waves pattern stitches.

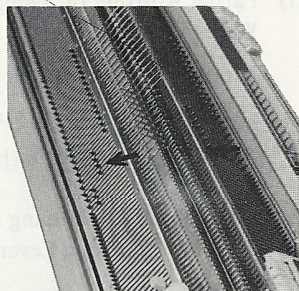

Fig. a

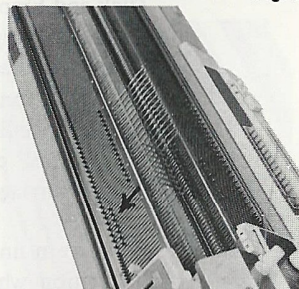

Fig. b

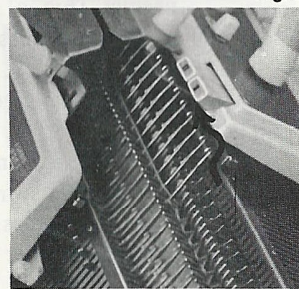

Fig. c

4) Partial knitting of tuck stitches

(A) Decreasing of knitting part

- (1) Push both buttons "I" of main carriage in.
- (2) Set the ribbing carriage as follows. (Fig. a)
Knitting Lever PLAIN at both sides
Partial Knitting Lever . . "I" at both sides
- (3) Move the needles not to be knitted of main knitter to "E" position.
- (4) Move all of the working needles of rib knitter to "E" position. (Fig. b)
- (5) Slide the carriages from right to left and knit one row.
- (6) Pass the yarn under the stem of the needle in "E" position which is adjacent to the knitted needles and slide the carriage from left to right and knit one row. (Fig. c)
- (7) Repeat the steps from (3) to (6) and knit the required number of rows.
- (8) Move the needles not to be knitted of main knitter to "E" position.
- (9) Move the needles to be knitted among the needles which have tucked stitches of rib knitter to "D" position. (Fig. d)
- (10) Repeat the steps (5) and (6).
- (11) Repeat the steps from (3) to (10) and knit the required number of rows.

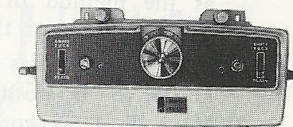

Fig. a

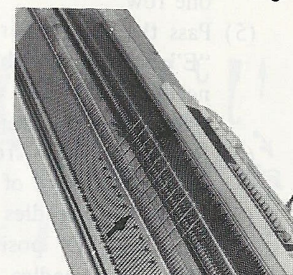

Fig. b

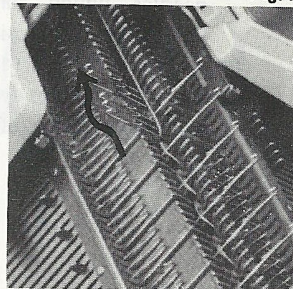

Fig. c

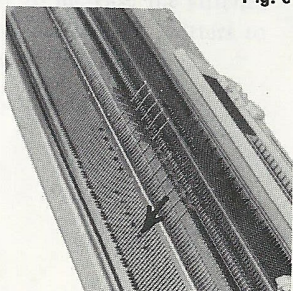

Fig. d

(B) Increasing of knitting part

- (1) Both carriages are to be set in the same way as the method of decreasing of knitting part, explained on the previous page.
- (2) Move the needles to be knitted of main knitter to "D" position. (Fig. a)
- (3) Move all of the working needles of rib knitter to "E" position. (Fig. a)
- (4) Slide the carriages from right to left and knit one row.
- (5) Pass the yarn under the stem of the needle in "E" position which is adjacent to the knitted needle, and slide the carriages from left to right and knit one row. (Fig. b)
- (6) Repeat the steps from (2) to (5) and knit the required number of rows.
- (7) Move the needles to be knitted of main knitter to "D" position.
- (8) Move the needles to be knitted among the needles which have tucked stitch of rib knitter to "D" position. (Fig. c)
- (9) Repeat the steps (4) and (5).
- (10) Repeat the steps from (2) to (9) and knit the required number of rows.

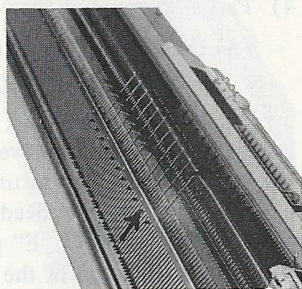

Fig. a

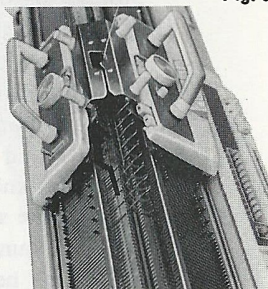

Fig. b

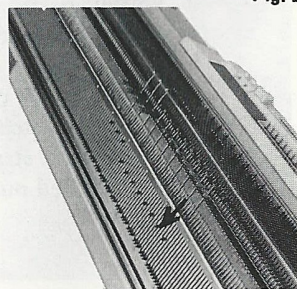

Fig. c

(14) Increasing Rib Stitches and Decreasing Rib Stitches

1) Increasing rib stitch

Method 1

On the same side as the carriage, place one empty needle into "B" position and knit across. (The needle will catch the yarn and will knit.)

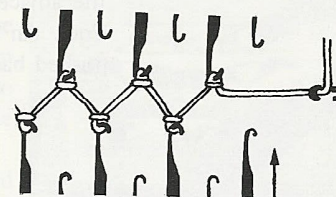

Method 2

Transfer the last edge stitch (of main knitter) onto the adjacent empty needle of main knitter with Transfer Tool.

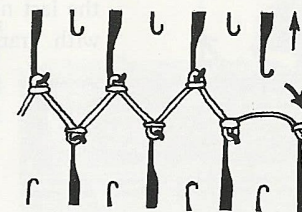

Pick up the purl side loop on the third needle and put it on the second vacant needle from the new end.

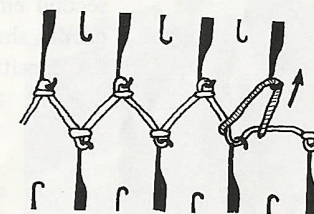

* Method of increasing more than 2 stitches

Place the carriages on the opposite side where you want to increase the stitches and pull out the required number of needles to be increased of both knitters to "B" position. Knit one row and the yarn is caught in the increased needles.

Hang the small knitting weights on the yarn and knit as you want.

2) Decreasing rib stitch

Method 1

Transfer the last edge stitch onto the adjacent needle with Transfer Tool. An empty needle should be pushed back to "A" position.

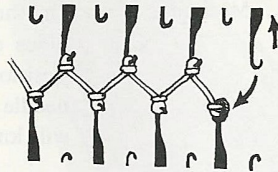

Method 2

Transfer the second stitch from the last needle to the third needle with Transfer Tool.

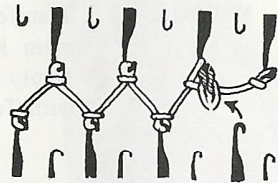

Transfer the edge stitches to the second empty needle. The empty needle should be pushed back to "A" position.

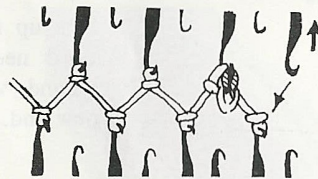

* Method of decreasing more than 2 stitches.

Place the carriages on the opposite side where you want to decrease the stitches. Thread another yarn into the seaming needle and pass it through the stitches to be decreased and take off stitches from the needles. The empty needles should be pushed back to "A" position.

6. IN SUCH CASES

(1) When the carriage sticks while knitting.

- 1) Do not move the carriage forcibly. Loosen the Fastening Knobs of ribbing carriage, and lift up the front part of the main carriage and slide it to the place where the knitting commenced. Slide the ribbing carriage to the same place gently.
- 2) Unpick the knitted stitches. Rearrange needles and place carriages as before.

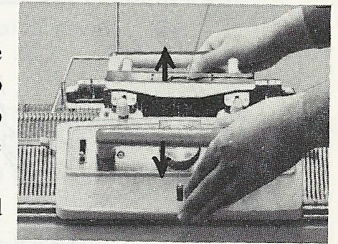

(2) Unpicking the stitches

When you have knitted the stitches more than you want, unpick unnecessary stitches. Pulling the end of yarn by hand and swinging the yarn backward and forward, and unpick the stitches of main knitter and rib knitter one by one.

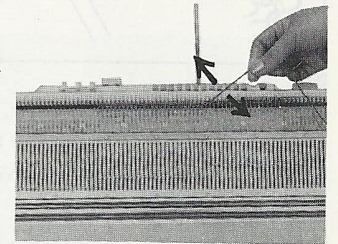

(3) How to pick up dropped stitches

- 1) Take off the weights from Cast-on Comb so that the dropped stitches do not run.
- 2) Drop down Rib knitter to middle position by pushing down the drop levers.
- 3) Pick up the dropped stitches with crochet hook and put them onto the needles.
- 4) When the dropped stitches happen in some rows, pick up the dropped stitches with latch needle tool attached to main knitter and make a loop and then transfer it onto the needles.

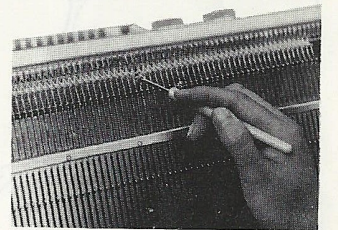
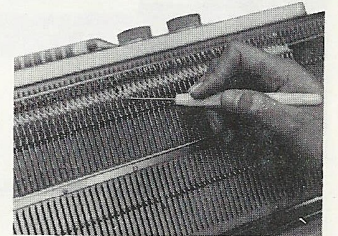

(4) How to convert stitches

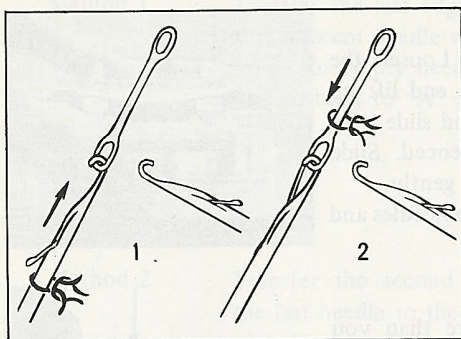

(Fig. a)

- 2) Inclining transfer needle, slide down the stitch to the opposite side. (Fig. b)

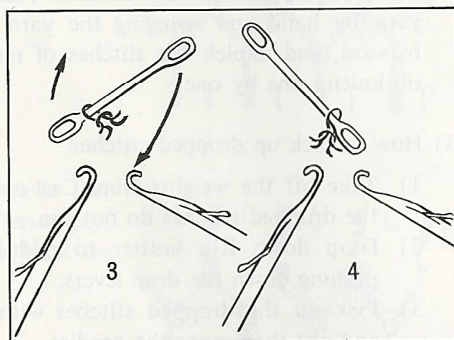

(Fig. b)

- 3) Hook the needle of main knitter and transfer the stitch on needle transfer to the needle of main knitter. (Fig. c)

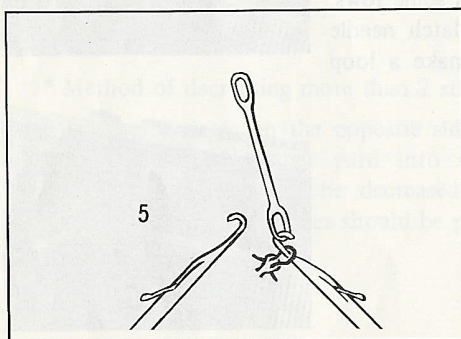

(Fig. c)

When converting from main knitter to rib knitter

By using two eyelet transfer needle, transfer the stitch from main knitter to rib knitter in the same way as the above steps.

(5) How to replace the needles

When the latch needles are broken or bent, refer to the Instruction Book of Main Knitter concerning the replacing method of the latch needle.

(6) How to remove the knitting from the machines

After knitting plain stitches for 5 or 6 rows with waste yarn, remove the knitting weights from the knitting, and then remove the yarn from the yarn feeder of carriage and slide the carriage across. You can automatically remove the knitting from the machines.

(7) How to use the main knitter with the rib knitter still connected

Take off the connecting arm from both carriages. Remove the ribbing carriage from rib knitter

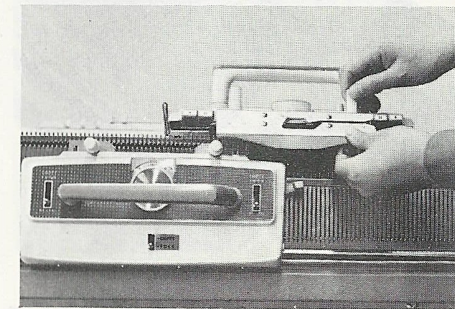

By pushing down the drop levers on both sides of rib knitter, drop down the rib knitter to lowest position.

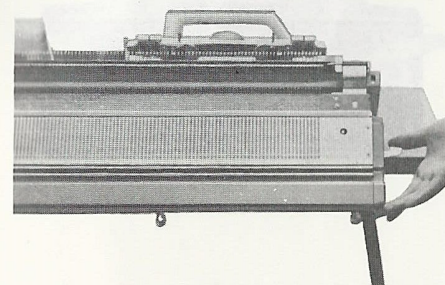

Install the fabric presser of main knitter to main carriage. Place main carriage onto main knitter and proceed to knit with punch card etc.

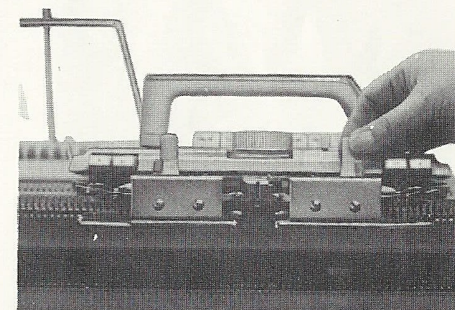

7. HOW TO TAKE CARE OF THE RIB KNITTER

Do not forget to take care of the machine always so that you use the machine in good condition for a long time.

After using the machine, wipe off dust and dirt of the machine with oiled rag. Clean the case and the carriage cover with a cloth soaked with neutral detergent.

* Never use thinner, benzine, alcohol and gasoline, to clean the machine.

(1) How to lubricate the machine

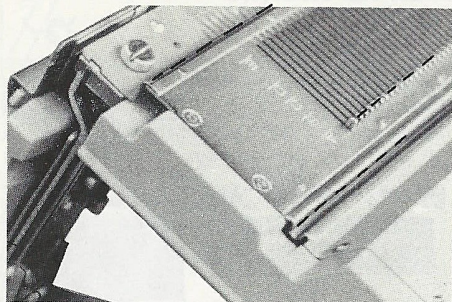

Oil the butt of latch needle with oiled rag. Never oil the latch and hook of the needle.

Wipe the back and front rail of needle bed with oiled rag.

Oil the knitting cams on the rear side of the carriage. (Each part in the dotted line as shown in the figures should be oiled.)

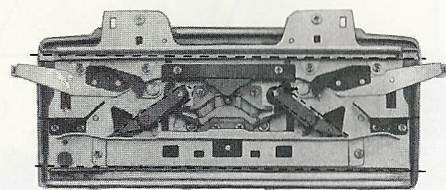

(2) Preservation

Preserve the machine in a dry and airy place.

MEMO