

**sweater machine**

# PATTERN BOOK

*for Beginners*

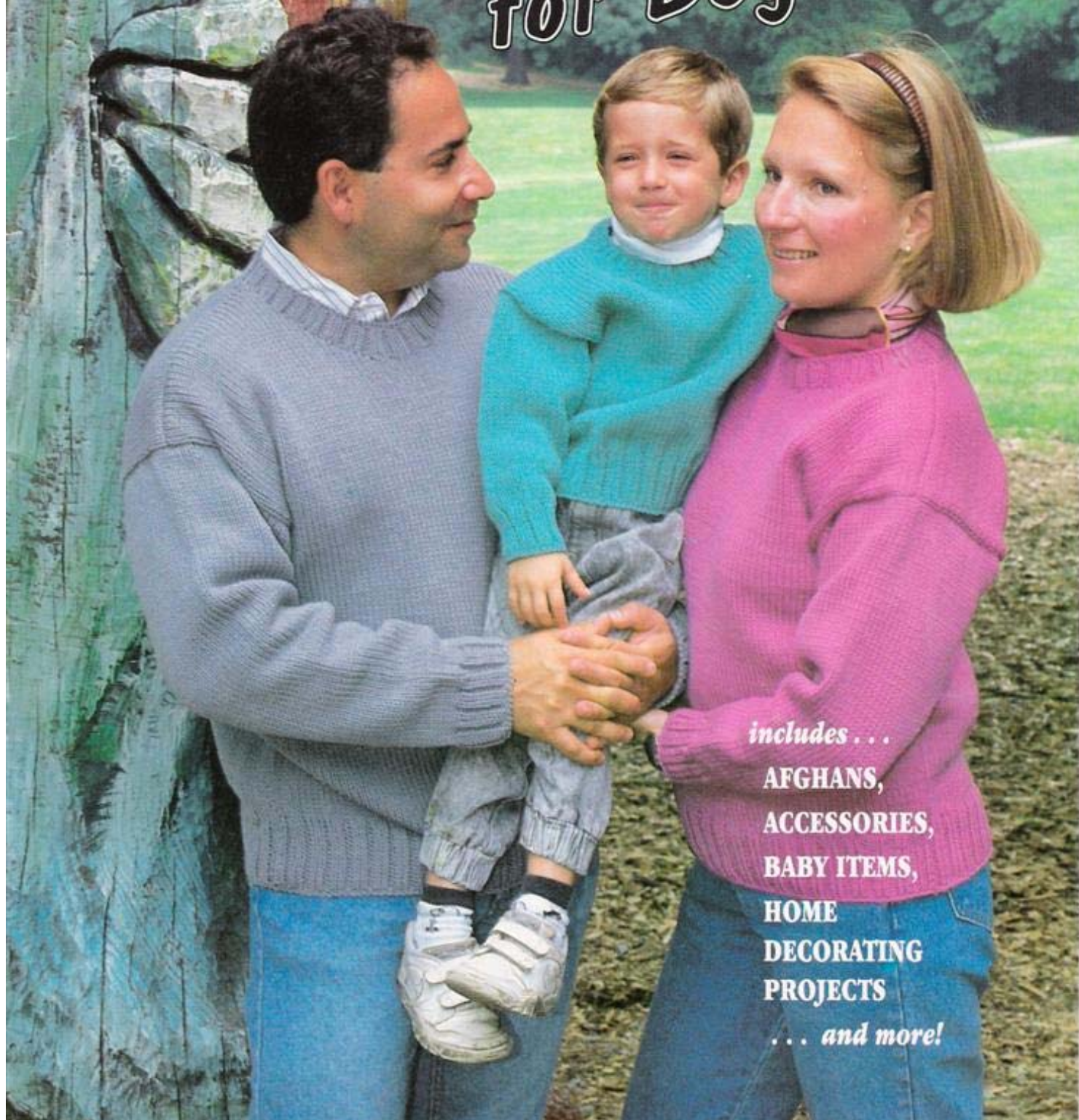

*includes . . .*

**AFGHANS,  
ACCESSORIES,  
BABY ITEMS,  
HOME  
DECORATING  
PROJECTS**

*. . . and more!*

*Quick-knit Scarf, Quick-knit Hat,  
Quick Knit Earwarmer*

*Baby Blanket*



*Afghan*

# PATTERN BOOK FOR BEGINNERS

## WELCOME TO THE CREATIVE WORLD OF BOND!

We have written this pattern book to make your introduction to knitting fun as well as productive.

These patterns assume you know nothing about knitting or knitting patterns.

### LEARN AS YOU KNIT

We will take you through a sequence of patterns. Each one will teach you something new, which will give you more knowledge and confidence, as you knit.

Your first three patterns are a scarf, hat and earwarmers. They can be knit for children or adults. Although you may not need a hat or scarf, **learning the techniques is important**, and we are sure know some deserving cold head or neck!

Read each pattern carefully before you start to knit. Make sure you understand what you will be doing and that you have everything you need. All the materials you need are listed at the front of each pattern. The new techniques you will be learning are also listed.

**It is important that you make the first three patterns before you start any of the other projects so you learn all you need to know.**

### TAKE YOUR TIME

Above all, remember, this is not a race. It's finishing at your own pace that is important. Gratification is achieved only upon successful completion of a project, not a poor job done too quickly.

If you get tired, take a break, then go back to your work. All of a sudden it will seem so clear and simple. Before long you will be making sweaters, toys, afghans and even designing your own things.

### LEARN WITH THE VIDEOS

To help you learn quickly we have an instructional video. Cheryl Brunette has also made two videos that give hints and tips and take you through making your first sweater. They are called "Meet Your Bond" and "Your First Bond Sweater". All these videos are available from us.

### HELP LINE

You can call or write to us at the following address if you have any questions, need help or want to enquire about accessories for your Sweater Machine.

Bond America, 435 Seventh Ave., Brooklyn, NY 11215 Tel: 718-832-3523 Fax: 718-832-0992

## USEFUL INFORMATION

### FOUR GOLDEN RULES

Follow these four golden rules when knitting

1. Use both hands on the handle and hold it firmly.
2. Push the carriage slowly and smoothly.
3. Take up the loop of slack yarn at the start of each row otherwise you will drop stitches.
4. Pull the yarn out of the centre of the ball so it runs freely otherwise you will get tight stitches.

If you have a problem turn to page 13 of the Instruction Book.

### TYPES OF YARN

All the yarn used in this book will be knit on either keyplate #3 or #4. Number 3 is for worsted weight yarn and number 4 for chunky (slightly heavier weight) yarns.

The yarns used in this book are from the following companies, and we would like to thank them for their participation in bring this book to you:

Caron International 150 Avenue E, Rochelle, IL 61068-1002

Coats and Clark 30 Patewood Drive, Greenville, SC 29615

Lion Brand Yarns 34 West 15th St, New York, NY 10011

### KNITTING DIFFERENT SIZES

Patterns are written to be knitted in different sizes. The sizes are given at the beginning of the pattern. The instructions for the smallest size are given first followed by the instructions for the larger sizes in brackets. Only follow the instructions for the size you are knitting.

If the pattern is written for three sizes, say bust/chest measurement 36", 38" and 40", then typical instructions may look like this; Knit 20 (25, 30) rows. This means for the smallest size you knit 20 rows, for the middle size 25 rows and for the largest size 30 rows.

### PHOTOCOPY YOUR PATTERNS

If you use your patterns over and over again then we suggest you photocopy them. You can

*continued over ...*

highlight the instructions for the size you are knitting and write your own comments on the pattern.

### COUNTING ROWS

You will need to count how many rows you have knitted. To help you remember, you can hang a small piece of yarn on the end needle every 10 or 20 rows. Or make hash marks on a slip of paper.

Alternatively you can use a row counter accessory for your Sweater Machine which will count your rows automatically. Row counters are available direct from us.

### KNITTING TABLE

Clamp your machine to a firm flat table. Wood or fibre board sewing tables are good. Metal card tables are not. The best table is a specially designed knitting table that can be folded when you want to store it away. These tables are available direct from us.

### SEWING UP

When you have finished knitting a sweater you will may need to join the pieces together. Joining the pieces together neatly is very important if you are to achieve a real professional finish.

In this book we show you how to join pieces on the machine which is fast and gives a neat finish. But some pieces will have to be sewn together. We show you which stitches to use but you may find it easier to use our specially designed "Sew Easy" to help you sew up seams neatly. The "Sew Easy" is available direct from us.

### YARN CARE

Before sewing up, let your fabric rest for a few hours after knitting so it will relax into shape.

To make it softer you can steam it, but **DO NOT REST THE IRON ON IT.** Just barely touch the surface of the knitting. To stop the knitting from curling, you can use T-pins, to pin out the pieces. Always follow the instructions on the ball band for laundering.

### ABBREVIATIONS

All knitting patterns contain abbreviations which make them easier to read. The list shows the abbreviations we use. Some of them, such as WY for waste yarn, may mean nothing to you now, but after knitting the first three patterns you will understand these terms.

You may want to photocopy the abbreviations so you don't have to refer back to the list when following your patterns.

## BOND KNITTING ABBREVIATIONS

alt	alternate
beg	beginning
BO	bind/cast off
CC	contrasting color
CO	cast on
COL	carriage on left
cont	continue
COR	carriage on right
dec	decrease
fol	following
FWP	forward working position, sts just behind open latches
gr	grams
HP	holding position
ins	inches
inc	increase
K	knit (or work; each pass of the carriage)
KP	keyplate
LHS	lefthand side
MC	main color
MY	main yarn
NWP	non-working position
oz	ounces
P	purl (side of work facing you as you knit, opposite side from knit side)
pat	pattern
R	row(s)
RC	row counter
rem	remain(ing)
rep	repeat
RHS	righthand side
st (s)	stitch (es)
st st	stockinette/stocking stitch (knit on RS, purl on WS)
tog	together
WP	working position
WY	waste yarn (extra yarn that is used as a stitch holder, to begin or end work with; not part of the garment)
X	times (as: inc 1 st every 4 R 5x)

## INDEX to PATTERNS

- |     |  |          |
|-----|--|----------|
| 1.  | QUICK-KNIT SCARF                         | Page 3.  |
| 2.  | QUICK-KNIT HAT                           | Page 4.  |
| 3.  | QUICK-KNIT EARWARMER                     | Page 5.  |
| 4.  | BABY BLANKET                             | Page 5.  |
| 5.  | AFGHAN                                   | Page 7.  |
| 6.  | BRAIDED RUG                              | Page 8.  |
| 7.  | BRAIDED NAPKIN RING                      | Page 9.  |
| 8.  | PLACEMAT                                 | Page 9.  |
| 9.  | CHILDRENS' FAIR ISLE VESTS               | Page 10. |
| 10. | BABY BUNTING                             | Page 12. |
| 11. | FAMILY PULLOVERS<br>- ADULTS' VERSION    | Page 14. |
| 12. | FAMILY PULLOVERS<br>- CHILDRENS' VERSION | Page 15. |

## PATTERN #1 QUICK-KNIT SCARF

We'll start with the scarf. The loose, drapy stitches are perfect for this design. These stitches are created by dropping every other stitch from the needles after you've knit the piece. The stitches open up, spread out and elongate. This is why the finished piece will look so much smaller until you drop the stitches.

### In this pattern you will learn:

1. How to weave a strand of yarn through open stitches.
2. How to make a tassel.
3. How to sew a seam.

**SIZES:** Child, age 3-6 (child, age 7-10; adult's size)

In the pattern, the instruction for the smallest size is given first followed by the instructions for the larger sizes in brackets e.g. Knit 100 (110, 120) rows. Only follow the instruction for the size you are knitting.

**MATERIALS:** Worsted weight yarn, in your choice of solid color, variegated (multi-colored) or tweed: one, 3-oz skein for all sizes. One skein will make one scarf with tassels.

### HERE'S HOW:

1. Bring forward 51 (57, 63) needles to holding position.
2. Hang the hem.
3. Push needles back to forward working position.
4. Thread carriage with the yarn, leaving an 18" length hanging down.
5. Using #3 keyplate in the carriage, knit 100 (110, 120) rows.
6. Cut yarn, leaving an 18" length. **DO NOT REMOVE THE HEM.**
7. Starting the second stitch from the edge, release every other stitch by pushing the needle forward to HP by holding the butt of the needle with your fingers (holding back the knitted fabric with your other hand at the same time), then pulling the needle back to NWP which closes the latch and drops the stitch.
8. After you've released these stitches, pull down on the hem so the stitches run down. You may need to coax the stitches at the side edges. When the hem hits the floor, you'll have to help the stitches run down using your fingers.
9. Thread the tapestry needle with the length of yarn at the cast-on edge and weave the needle

through the stitches remaining attached to the hem, to stop them running when you remove the hem.

10. Remove the hem carefully, by snipping the elastic with scissors.
11. Thread the tapestry needle with the length of yarn at the end of your work and weave through the stitches on the needles.

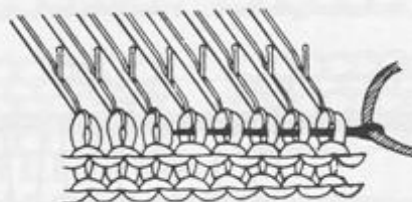

12. Remove the knitting from the needles.
13. Cut a separate length of yarn (about 1½ times the length of the scarf) and sew the side seam so the scarf will be like a tube, with the knit (not purl) side on the outside. Use Blind Stitch. See the illustration. Do not pull the stitches too tightly or the scarf will appear gathered at the seamed edge.
14. Gather the stitches at each end and tie the yarn.
15. Weave the loose end of yarn into the center of the scarf.
16. Make 2 tassels: Make a tassel by winding the yarn around a piece of cardboard that is about 5" wide. Thread a separate length of yarn through the yarn at the top edge of the cardboard. Cut the yarn along the opposite edge, releasing the cardboard. Wind another length of yarn around the top of the tassel about 1" down from the end where the loose yarn is tied and secure. Tie the tassel to the end of the scarf. Repeat for second tassel.

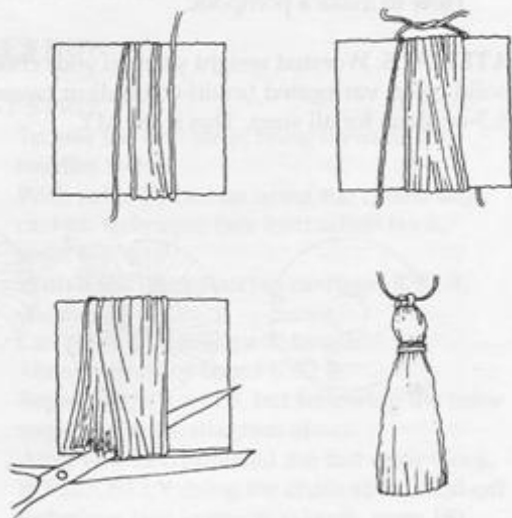

How to make a tassel.

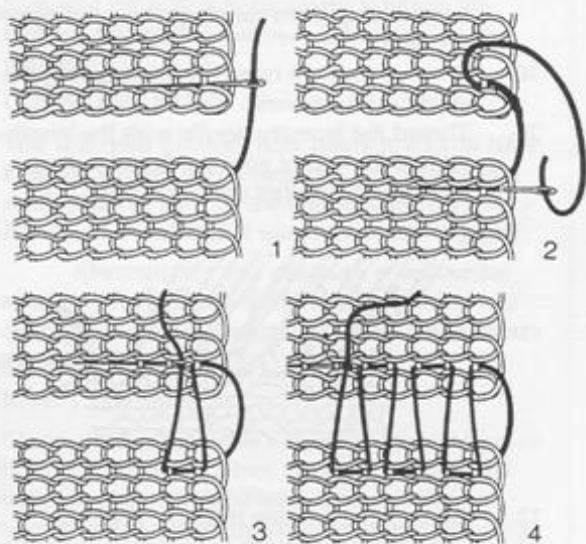

How to do Blind Stitch.

## PATTERN #2 QUICK KNIT HAT

Because of knitting's natural characteristic of rolling at the edges, the hat forms a natural rolled brim at the cast-off edge.

You will begin to knit using waste yarn (WY). This is any spare yarn you have of the same type as your main yarn (MY). It is never listed under "Materials" as it is considered to be a necessity.

In this pattern you will learn:

1. How to use waste yarn.
2. How to make a pompom.

**MATERIALS:** Worsted weight yarn, in your choice of solid color, variegated (multi-colored) or tweed: one 3-oz skein for all sizes. This is the MY.

**SIZES:** Child, age 3-6 (child, age 7-10; adult's size)

**HERE'S HOW:**

1. Bring forward 70 (78, 86) needles to HP (holding position). COR (carriage on right).
2. Hang the hem.
3. Push needles back to FWP (forward working position).
4. Thread carriage with WY (waste yarn).
5. With #3 keyplate, knit 6 rows.
6. Break off WY.
7. Thread carriage with MY (main yarn), leaving a 24" end.
8. Knit 47 (53, 59) rows. COL (carriage on left).
9. BO (bind off) using the backstitch technique (page 12 of Instruction Book).
10. Remove your work from the machine.
11. Remove hem. You will now have your hat attached with the WY.
12. Thread the tapestry needle with the length of yarn from the first row of the MY. Weave the yarn through the stitches of the first row of the main yarn to stop them running when you remove the WY. Be sure you weave through the actual stitches, not the space between the stitches.
13. Unravel the WY.
14. Sew the side seam using the same technique as for the scarf.
15. Gather the sts (stitches) using the yarn woven through the loose sts and secure.
16. Make pompom: Cut two 5" diameter circles from cardboard. Mark the center of the circles. Cut to the center and cut a small circle (about 1/2" diameter) in the center of each of the large circles. Wind yarn around both circles through the slit until the circle is filled fully (see illustration below). Thread the tapestry needle with a length of the main yarn and wind around center of smaller circle. Pull tightly and secure. Cut yarn around edge of circle and between the two pieces of cardboard.
17. Sew pompom to top of hat.

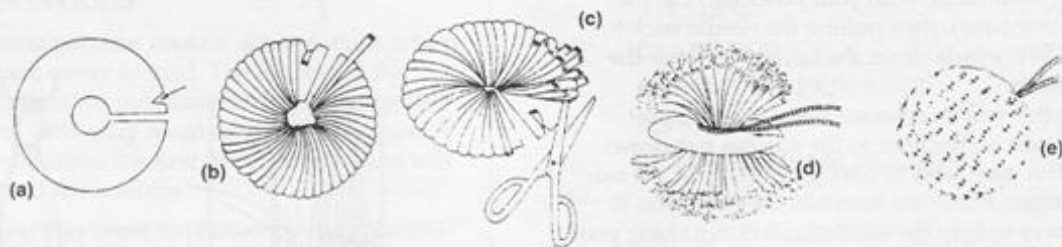

How to make a Pompom.

## PATTERN #3 QUICK-KNIT EARWARMER

In this pattern you will learn:

1. How to knit stripes.

**MATERIALS:** Worsted weight yarn, in your choice of solid color, variegated (multi-colored) or tweed: one 3-oz skein for all sizes; this is the main color (MC). Small amount of contrast color (CC) for stripes.

**SIZES:** Child, age 3-6 (child, age 7-10; adult's size)

**HERE'S HOW:**

1. Bring forward 58 (66, 76) needles to HP. COR (carriage on right).
2. Cast on using the closed-edge cast on. (see instruction book, page 17.)
3. Hang the hem.
4. Push needles back to FWP.
5. Thread carriage with MC (main color)
6. With #3 keyplate, K (knit) 18 R (rows).

**HERE'S HOW TO KNIT A STRIPE:**

7. Remove yarn from carriage (DO NOT CUT IT) by lifting up the handle and pulling the fabric guide away from the side of the carriage. After you have removed the yarn, move it out of the way so it doesn't catch in the carriage. Replace fabric guide and handle.
8. Thread CC (contrasting color, of main yarn) in the usual way but hold the MC and the CC with the clip (remove it from the yarn at the first row).
9. K (knit) 2 R (rows) in CC.
10. Remove CC from carriage just as you did for the MC and replace it with the MC.
11. With MC, K 2 R.
12. Remove MC from carriage again and replace with CC.
13. With CC, K 2 R.
14. Break off CC, leaving a 3" tail.
15. Replace with MC and K 17 R. Carriage ends on left.
16. Break off MC, leaving a 24" length.
17. BO (bind off) using the backstitch technique.
18. After letting the piece rest, steam (remember - don't press) the piece.
19. Sew the short ends together into a ring, using the technique described for the scarf.
20. Fold the earwarmer so the wrong side is inside and sew the cast-on and bound-off edges together. (Overcast st is fine because the seam will not be seen.)

Now, depending on the type of things you want to make and your level of confidence, you may proceed to any of the designs in this book. Please keep in mind that the easiest patterns are the baby blanket, afghan, the toy and the braided rug. The more challenging patterns are the placemat, the childrens' vests, the family crew-neck pullovers, and the bunting. You will learn something new for each.

## PATTERN #4 BABY BLANKET

This blanket is made in three panels of five stripes (see diagram below). When put together using the seam-as-you-knit technique, the "stripes" create blocks of color.

In making this blanket, you will learn:

1. Seam-as-you-knit technique. Your blanket will be finished when you remove it from the machine.
2. Duplicate stitch. This is used for the lettering in the center.
3. Single crochet. This is used for the edging at the sides and is optional.
4. Attaching fringe.

**MATERIALS:** Caron International's DAZZELAIRE 3-oz skeins brushed worsted weight yarn: 1 skein white (color #2601) - color A; 2 skeins each of yellow (color #2617) - color B and green (color #2836) - color C; 4 skeins baby yellow/green/white mix (color #2665) - color D; size H crochet hook.

**FINISHED DIMENSIONS:** 30" x 44"

**HERE'S HOW:**

**FIRST STRIP**

1. To knit the first strip, bring forward 40 needles to HP.
2. With color D, cast on using the closed-edge cast-on technique (see instruction book, page 17).
3. With #3 KP (keyplate) in carriage, K 52 R, ending COR.
4. Cut color D, leaving a 3" length.
5. Thread up color B and K 52 R.
6. Repeat steps 4 and 5, but following the color sequence in the diagram above.
7. After you've completed the last color block, BO LOOSELY using the chain stitch bind-off technique (see instruction book, page 19).

1st Strip	2nd Strip	3rd Strip
D	C	D
B	D	B
D	A	D
C	D	C
D	B	D

Diagram of Blanket.

#### HERE'S HOW TO SEAM-AS-YOU-KNIT.

This technique is very popular with people who like to knit afghans and do not like to sew the pieces together later, but rather to do it as they knit. You will join every other stitch along the edge of the first strip to the edge of the second strip as you knit it.

8. To knit the second strip, cast on using the closed edge cast-on technique as for the first strip, but start with color C.
9. Following the technique shown in the illustration, with the wrong side of the first strip facing you, hang the loop of the first stitch of the *second row* onto the first working needle on the left hand side.
10. K 2 R ending COR.
11. Now hang the first stitch of the *fourth row* onto the first working needle on the left hand side.
12. K 2 R ending COR.
13. Continue by repeating the last two steps, hanging *every other* stitch of the first strip onto the left hand edge needle to be knit into the second strip, until you have knit 52 rows.
14. Change color yarn and continue following the color sequence above, until you have knit the

entire second strip which will now be joined to the first strip.

15. Now knit the third strip in the same sequence as the first, joining the second strip edge to it as you knit.

*An alternative method of joining afghan strips is shown later in the book for a larger afghan.*

#### NOW TO CROCHET.

Many of you already know how to crochet, but there are many of you who do not. Although crocheting is not a factor in being able to knit with your machine, a simple crocheted edging makes for a good and often decorative finished edge when ribbing is not used and is particularly good for afghan edges. You can find basic crochet instructions in many craft magazines or knitting books.

For this blanket, use a size H hook. Work one single crochet in two of three knit stitches along each of the long edges.

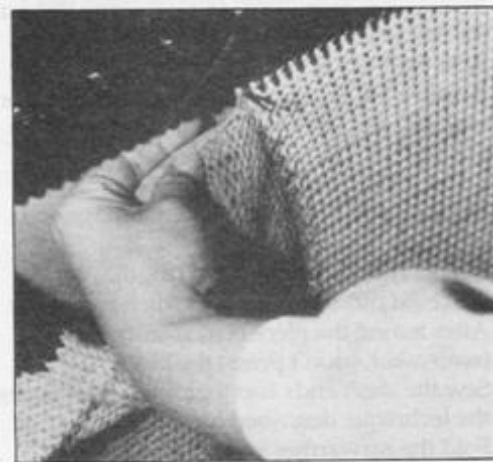
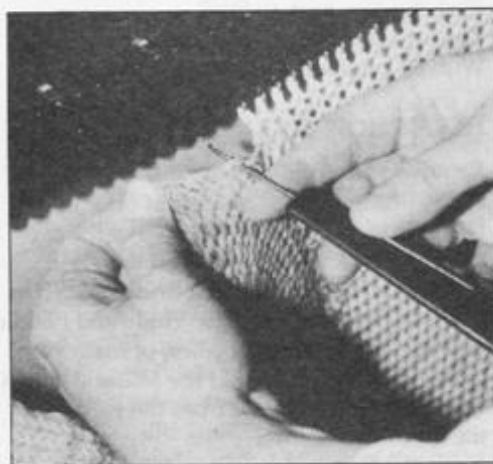

*Seam as you knit.*





### THE FRINGED EDGE

This edge is often used for afghans. It is a very attractive decorative touch, and it also keeps the edge from curling up. Here's how:

1. Cut a piece of cardboard 8" long by 5" wide. Using color D, wind the yarn around the narrower width of the cardboard a number of times.
2. Cut yarn on cardboard along one edge.
3. Use a spare crochet hook size H or I, and three strands of cut yarn folded in half. Insert the crochet hook from the wrong side, draw the group of strands through one of the edge stitches at the narrower end of the blanket. Draw this loop through part-way, then, with the loop still on the hook, draw through the cut ends of the yarn and tighten.
4. Steam the fringe to even it and trim if necessary.

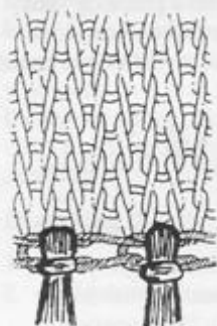

*Fringed Edge.*



### DUPLICATE STITCH

This embroidery stitch is well-known by many of you, but for those of you who are new to this technique, it is very versatile and looks wonderful. You are actually "duplicating" a knitted stitch on top of the base knitting. This is perfect for lettering (as in this blanket), for filling in small sections of color that would be very time-consuming to knit, and for fixing mistakes of color in Fair Isle or Intarsia.

For this blanket, thread the tapestry needle with green. Work the chart starting the 13th stitch down from the top and 5th stitch in from the left side edge of the white color block in the center of the blanket.



*Duplicate Stitch.*

## PATTERN #5 AFGHAN

This full sized afghan is also very easy to knit - perhaps too much so! It is made from strips that are joined in a type of braid after the pieces have been knit. Two stitches are unravelled to make side loops that are crocheted together with the loops of the adjoining strip. DO NOT steam the pieces until you have unravelled the side stitches.

**In making this afghan you will learn:**

1. The latch-up join for the strips

**MATERIALS:** Coats and Clark's RED HEART SUPER SAVER 8-oz skein worsted weight yarn: 3 skeins Windsor Blue (color #380) - color A; 2 skeins Country Rose (color #374) - color B; size H crochet hook; size I or larger crochet hook.

**FINISHED DIMENSIONS:** 48" x 60"

## HERE'S HOW:

### Right edge strip:

1. Bring forward 36 needles to HP.
2. With color A, cast on using the closed edge method (see instruction book, page 17).
3. K 339 R ending COL. Make sure the edge sts all knit otherwise they will not un-ravel to form loops.
4. BO 34 sts loosely using the chain stitch method. Leave the last two sts on the right not bound off. These sts will be un-ravelled to form loops.

### Left edge strip:

5. Bring 36 needles forward to HP and with color A cast on using closed-edge method.
6. K 338 R ending COR.
7. Push last two needles on LHS into HP.
8. K 1 R ending COL. The two needles in HP won't have knitted.
9. BO using chain stitch method leaving the two sts on LHS in HP not bound off. These will be un-ravelled.

### Center three strips:

(make one in color A and two in color B):

10. Bring 32 needles forward to HP and cast on using closed-edge method.
11. K 338 R ending COR.
12. Push last two needles on LHS into HP.
13. K 1 R ending COL.
14. BO using chain st method leaving the last two sts on LHS and the last two sts on RHS not bound off. You will have bound off 28 sts in all. These edge sts will be un-ravelled.

### HERE'S HOW TO JOIN THE STRIPS:

11. Unravel the two loose stitches on each side of the center strips, forming large loops at each side. Unravel the two loose stitches at the inside edges of the side strips.
12. Line up the strips so there is the left blue strip, one rose strip, one blue strip, one rose strip, then the right blue strip.
13. Using the larger crochet hook and catching three loops at a time, catch the first group of three loops on the right strip, then catch the second group of three loops on the left strip, bringing them through the first set. (See next illustration.) Continue in this way until all loops have been caught. Secure last set of loops at one of the edges. Work this technique until all the strips have been joined.
14. Make one row of single crochet around the edges (optional, but it helps to keep the edges from curling).

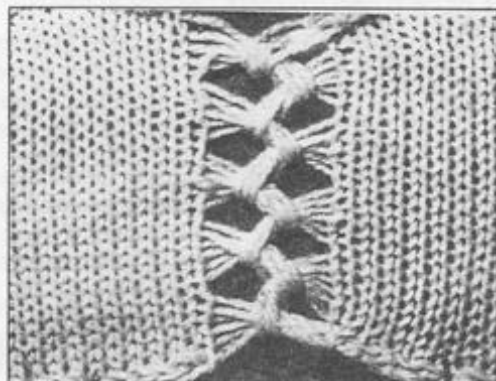

## PATTERN #6 BRAIDED RUG

Again, this is one of those super-easy patterns that is almost too easy. However, because of the popularity of these rugs, we decided to include it in this book. You can easily interrupt your work by removing the stitches onto WY or thread a piece of yarn through the open stitches and remove your work from the machine. You may want to do this to braid the pieces in stages.

**FINISHED DIMENSIONS:** 21" x 25" oval.

15 ft. each of three knitted strips = 11 ft. of braid.  
31 ft. of braid makes this rug.

**MATERIALS:** Coats and Clark's RED HEART SUPER SAVER 8-oz skein worsted weight yarn: 2 each of the following colors: Country Blue (color #382); Country Rose (color #374); Wedgewood (variegated) (color #392).

### HERE'S HOW:

1. Bring 5 needles forward to HP (You won't be able to use the green cards, so you'll have to hold the needles forward with your hand).
2. With WY (waste yarn) cast on open edge method, the first color (instruction book, page 9) and K 2 R.
3. Hang one of the small weights on the knitting and remove the hem, as it is too heavy for only 5 stitches. The small weight will be enough.
4. Knit 15 feet, moving weight up as you knit.
5. Break off main yarn and weave through loose stitches. Remove from machine and tighten.
6. Knit 15 feet strips of the other two colors.
7. Braid strips, keeping the raw edges to the wrong side, but let them curl naturally to the wrong side.
8. Thread tapestry needle with a length of blue yarn.

9. Fold the braid in half at 8" and secure.
10. Wind braid, sewing down on the wrong side as you go, until entire braid is used.

## PATTERN #7 NAPKIN RINGS

This pattern isn't really a "pattern" as it is the same technique and yarn as the braided rug. You may wish to make it narrower by using only 3 needles instead of 5. Following the instructions for the braided rug, make an 8" long braid. Secure at each end and tie together to form a ring. That's it!

## PATTERN #8 PLACEMATS

Although these seem simple enough, you will be learning an important technique, so it's best you learn it on a simple project. This technique is a picot edge formed by a casing. Certainly much easier than it sounds. You will also be weaving ribbon through the eyelet edges. Both of these techniques can be used for hems and edgings of afghans as well as other uses.

**In making the placemats you will learn:**

1. Picot edge.
2. Making a casing.

**FINISHED DIMENSIONS:** 12" x 16"

**MATERIALS:** Coats and Clark's RED HEART SUPER SAVER 8-oz worsted weight yarn: 1 ball (4 placemats) Country Blue (color #382); 2 yds. 1/2" ribbon; size H crochet hook.

**HERE'S HOW:**

1. Bring forward 63 needles to HP.
2. With WY cast on open edge method and K 6 R. Break off WY.
3. K 2 R with MY.
4. Make one eyelet stitch (page 23 of the instruction book) on every other needle starting the third stitch in from the side edge.
5. K next row slowly.
6. K 2 R. COL ending COL.

**NOW FOR FORMING THE PICOT EDGE:**

7. Using the 3-prong tool (or 1-prong if you feel more comfortable with it), and starting on the

left hand side, lift the stitches from the first row of the MY up onto the needles directly above. There will now be two stitches on each needle. You will need to use the small weights to hold down the knitting until you come to it. You will have a folded edge (hem, casing) that will be knit right in and have a decorative edge from the eyelet row.

8. K the next row *slowly*.
9. K 6 R. ending COR.
10. Make another row of eyelets as in step #4.
11. K 4 rows.
12. Make one eyelet on each side, 3 sts in from the side edge.
13. K 4 R.
14. Repeat steps 12 and 13 five times, until there are 48 rows above the last full row of eyelets.
15. Repeat steps 4 and 5.
16. K 5 R. COR.
17. Repeat steps 4 and 5.
18. K 2 R and break off MY, leaving a 2' length of yarn.
19. K 6 R WY.
20. Break off WY and remove placemat from the machine.

**FINISHING:**

This is a section that is nearly always at the end of each pattern. It tells you how to put things together so you have a totally professional looking garment or item.

Here's how to "finish" your placemat: After you have let the placemat rest and have steamed it, fold the edge with the WY to the wrong side, to form a hem casing, (it should look like the opposite side that was knit in) and pin across. Thread the tapestry needle with the yarn attached to the last row of the MY. Catch one loop of the last row of the MY (the WY is still attached) and one of the purl "bumps" on the back of the placemat. Pull through the yarn. Repeat this across the row, but do not pull the yarn too tightly or you will get a gathered effect. Then remove the WY from both ends.

Make a row of single crochet along each of the shorter sides of the placemat. Optional: make a row of reverse crochet on top of the row of single crochet. Steam edges again. Weave ribbon through the eyelets around the mat and secure on the underside where the ribbon meets.

## PATTERN #9 CHILDRENS' FAIR ISLE VESTS

These easy-to-knit vests will introduce you to doing ribbing on a garment. The ribbing is knitted last whether round the cuffs, neck or bottom.

In making these vests, you will start at the front, come over the shoulders and then down the back in one piece. You will form the neck opening as you knit.

The ribbing at the front will be done after the vest has been taken off the machine, while the ribbing at the back will be done at the end before you take the vest off the machine.

### In making the vest you will learn:

1. How to do ribbing last, after finishing rest of the knitting.
2. How to test for gauge.
3. How to understand schematics or diagrams of garments.

### GAUGE:

Before we continue it is necessary to understand the importance of gauge now you are knitting for a particular size. Gauge ( or tension ) is the number of stitches and rows to the inch you get with the yarn you are using. Patterns are written assuming a particular gauge. If you don't knit to that gauge when following the pattern then your vest will be the wrong size and not fit.

To test for gauge you knit a square with your yarn and count the number of stitches and rows to the inch that you are getting.

### Here's how to do it:

1. Bring forward 40 needles to HP and cast on in WY. Knit 6 rows. Break off WY.
2. With MY knit 50 rows. Break off.
3. With WY knit 6 rows and remove swatch from machine.

Pull the swatch into shape by pulling down firmly from the top to bottom. Leave it to relax for a few hours then pin it out on a towel and steam it. Take a tape measure and in the middle of the swatch, count the number of stitches across 4" and the number of rows down 4". Gauge is given in patterns for 4". Gauge is written in patterns like this:

**GAUGE:** In st st (stockinette stitch) and using a #4 KP: 16st and 23 rows =4". This is the correct gauge for this pattern.

**SIZES:** 4 (6, 8)

**FINISHED CHEST MEASUREMENT:** 26 (28, 31)"

**MATERIALS:** Chunky weight yarn (slightly heavier than worsted weight. A common chunky weight is Lion Brand's Jiffy or Jiffy Basic, which we used for this pattern): 2 (2, 3) balls MC (main color); 1 ball CC (contrasting color).

### FRONT:

1. Put a #4 KP into the carriage.
  2. Bring forward 52 (55, 62) needles to HP.
  3. Using WY and the open edge technique, CO and K 6 R.
  4. Break off WY.
  5. Thread up MC and K 32 (36, 40) R ending COR.
  6. Work Fair Isle design (chart below) over next 9 rows for the boy's design and 8 rows for the girl's design. (K 1 additional row for the girl's design after you work the Fair Isle pattern.)
- Following the chart below and starting in the middle of your needle bed to center the design, bring forward the needles you want to have in the CC. Follow the directions for knitting Fair Isle on page 26 in your instruction book. End COL.
7. K 9 R.

### NECK OPENING:

8. Using a separate length (about 1 yd.) of MC and using the chain stitch method, BO the center 22 (23, 26) sts. This forms the neck opening.

Girls Design

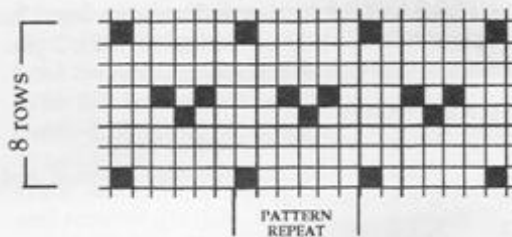

Boys Design

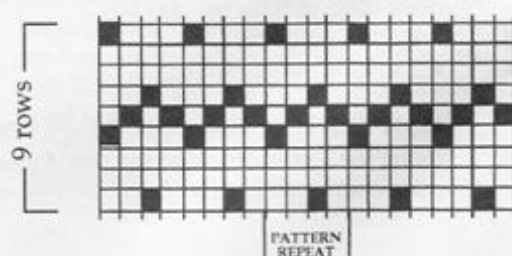

### BACK:

To knit the back you are going to re hang the hem on the needles but before doing so you must cast on the center sts again. DO NOT REMOVE THE KNITTING FROM THE NEEDLES.

9. To cast on the centre needles, use a spare length of MC yarn and the closed edge cast on method by winding the yarn round the needles. Leave both ends of the yarn hanging down after casting on.
10. Push all the needles forward into HP using the green cards. Make sure the shoulder stitches are pushed right back against the bed.
11. Holding down the knitting with the two small weights, remove the weighted hem, but DO NOT REMOVE the knitting from the machine.
12. Hang the hem on the needles as usual.
13. K 50 (54,58) R ending COR.
14. Decrease 1 st on each side. There are 50 (51, 58) sts remaining.

### BACK RIBBING:

15. Work ribbing over 12 rows exactly as described in the instruction book page 21.
16. BO using backstitch and remove your work from the machine.

### FRONT RIBBING:

17. Bring forward 50 (53, 58) needles to HP. COR.
18. With the wrong side of the knitting facing you, pick up as many sts across the first row of the MC. (See the illustration below.) You will need to put 2 sts on the first needle.
19. Remove every third stitch onto a length of WY and push the empty needles back to NWP.
20. Push the knitting back against the bed so the sts are behind the open latches.
21. Hang the hem in the usual way.
22. K 11 R. ending COL.
23. Latch up the sts on the WY in the usual way.
24. BO in backstitch.

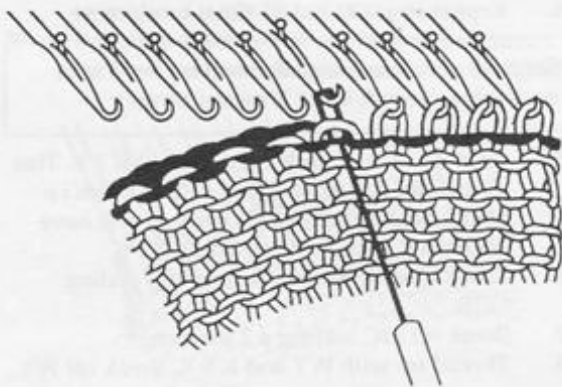

If you are a handknitter, you may knit the ribbing by hand then put it on the machine. First, work the increases along the last row of the ribbing and knit 1 row of st st. Bring forward the number of needles you will be using for the body of the sweater. With the wrong side of the knitting facing you (use the small weights to hold down the ribbing as you go,) use the 1-prong transfer tool to put the ribbing onto the needles. (See the illustration.) Then hang the hem.

### FINISHING:

Because the vest was knit in one piece, there is very little finishing to do. Secure and weave in the spare yarn at the neck edges. Sew side seams as for the hat pattern, leaving a 5 (5½, 6)'' opening for the arms.

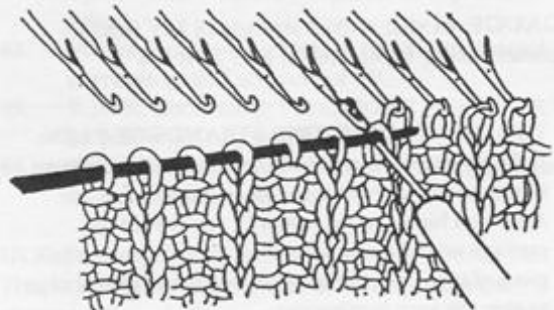

### SCHEMATICS:

This is the term used for the diagrams of the sweater pieces. These are to check the measurements against yours. You may want the sweater longer or shorter, wider or narrower. Please keep in mind that when giving the measurements, they are the finished measurements of the garment when it is sewn together.

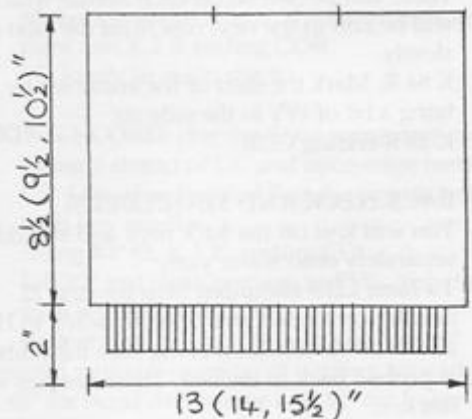

## PATTERN #10 BABY BUNTING

Because you will be doing more shaping than in any other project so far, you will be learning (and reviewing) everything you need to knit well.

### In knitting this bunting you will learn:

1. To shape a neckline by putting needles onto HP.
2. How to knit two strands of thin yarn together to make a heavier yarn.
3. To make an I-cord (idiot cord. You'll know why they call it that when you make it.)
4. How to make a casing for a drawstring.

**SIZE:** Newborn

**MATERIALS:** Lion Brand Yarns' JAMIE: 5 skeins Toddler Print (color #231) - MC; 1 skein Orchid #255 - CC.

**GAUGE:** In st st with 2 strands of MY held together, using #4 KP: 16 sts and 23 R = 4"

### TIPS ON HOLDING TWO STRANDS OF YARN:

Pull one strand of yarn from the center of 2 different skeins and hold them together as if they were one. After you have cast on with WY and thread the carriage with the two strands of the MY, put a small piece of tape over the front of the nose of the carriage to stop the yarn coming out.

### BACK:

1. Bring forward 62 needles to HP.
2. K 6 R in WY. Break off.
3. With MC (both strands), K 12 R.
4. Now, starting from the left edge and using the one prong tool, lift the sts from the first row of the MC up onto the needles directly above making the casing for the drawstring. There will be two sts on each needle which will be knit in the next row. Knit the next row slowly.
5. K 84 R. Mark the start of the armholes by tying a bit of WY to the side sts.
6. K 28 R ending COR.

### BACK NECK AND SHOULDERS:

You will knit off the back neck and shoulders separately onto waste yarn.

7. **To form LHS shoulder:** Skip the first 22 needles on the left and bring forward to HP all the other needles making sure the knitting is pushed back to the bed. These needles will not knit.

8. Remove MC from carriage and cut, leaving a two foot length.
9. Thread carriage with WY and K 6 R on the 22 needles. Break off WY. (You may need to use the small weights where the needles in HP meet the needles in WP (working position)).
10. Bring these 22 needles up to HP making sure the knitting is pushed back to bed.
11. **To form back neck:** Push center 18 needles back to FWP.
12. Thread up with WY and K 6 R on these 18 needles. Break off WY.
13. Bring these 18 needles up to HP pushing the knitting back to the bed.
14. **To form RHS shoulder:** Push last 22 needles back to FWP.
15. Thread up with WY and K 6 R. Break off WY.
16. Remove work from needles.

### FRONT:

17. Cast on and work the same as for the back, except on row 8 make two eyelets, one to the left and one to the right, of the center needle.
18. Continue as for back until you have knit 16 rows above the armhole markers, ending COR.

### SHAPE NECK:

To shape the neck you will first bind off the sts that form the bottom of the neck. Then the RHS of the neck will be knit with the needles on the LHS in HP so they do not knit. Then you will go back and knit the LHS of the neck with the RHS needles in HP.

19. **To form bottom of neck:** BO center 4 sts using chain stitch cast off with one strand of MC.
20. Push these 4 empty needles back to NWP.
21. **To form RHS of neck:** Push the needles to the left of the bound-off sts up to HP making sure the knitting is pushed back against the bed.
22. Work right side only. K 1 R ending COL.
23. Dec (decrease) 1 st at neck edge (carriage side) then K 1 R ending COR.
24. Repeat steps 20 and 21 three times more.

Steps 20 and 21 are usually written: dec 1 st at neck edge every R 4 X. ( X means times ).

25. Then dec 1 st at neck edge every 2 R 3 X. This means dec 1 st every 2 rows three times i.e. after knitting the next 6 rows you will have decreased 3 sts at the neck edge.
26. Knit 2 more rows (no decreasing) ending COR.
27. Break off MC leaving a 2 foot length.
28. Thread up with WY and K 6 R. Break off WY.

29. Push these needles up to HP making sure the knitting is pushed against the bed.
30. To form LHS of neck: Push needles on LHS back to FWP. Make sure the latches are open.
31. Thread up with MC and repeat steps 22 to 28 to knit LHS of neck.
32. Remove work from machine.

#### JOINING A SHOULDER SEAM TOGETHER

You can join shoulder seams by either sewing them together or by joining them on the machine which is quick and neat. To join them on the machine, you hang the stitches of both shoulder edges onto the needles and knit them together.

33. Bring forward 22 needles to HP. COR.
34. With the *right side* of the FRONT of the bunting facing you, hang the shoulder stitches from the last row of the MC onto the needles in HP. To see the first row of the MC better, fold the WY over toward you and pick up the "bump" of the MY. (See illustration below). Use the small weights to hold down your knitting as you hang on the stitches.

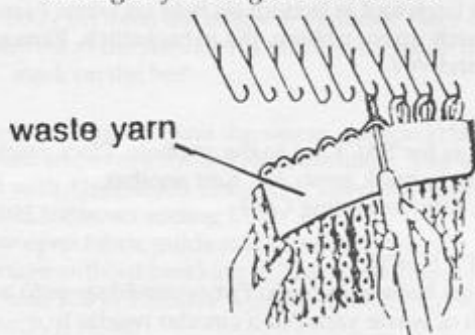

35. When you have all the stitches on the needles, push the stitches back against the bed *behind* the open latches.
36. With the *wrong side* of the BACK of the bunting facing you, hang the stitches from the last row of the MC onto the hooks of the needles in HP. There will be 2 stitches (2 strands each, remember) on each needle, one in the hook and one behind the latch.
37. Bring the stitches that are behind the latches forward and over the stitches in the hooks of

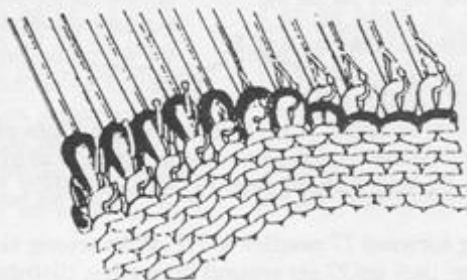

the needles. (See illustration below.) There is only one stitch on each needle now.

38. Thread the carriage with the MC attached to the front or back of the bunting. K 1 R. BO loosely in chain stitch.
39. Repeat for other shoulder.

#### SLEEVES:

The sleeves are knit right into the armholes of the body, and then knit down to the cuffs. This will only work when you are doing plain knitting or stripes, as any design would be knit up-side down.

40. Bring forward 44 needles to HP.
41. With the wrong side facing you, pick up 44 sts from the body of the sweater between the armhole markers. There are more rows at the armhole edge than there are needles, so you will need to skip an occasional row/stitch as you work. There should be approximately 2 stitches picked up for every three rows. Pick up the whole stitch, not just the loop at the edge.
42. When you have picked up the 44 sts, thread carriage with 2 strands of MC.
39. K 36 R, decreasing 1 st each end every 4 R 8 X as you knit. You will have 28 sts remaining.
44. K 6 R. These last 6 R will roll to the right side as a decorative edge.

#### HOOD:

This is knit from side to side with a seam at the center back.

45. Using MC and the closed-edge method, CO 32 sts.
46. K 2 R. Make one eyelet st on the fourth st from the right.
47. K 32 more R.
48. Decrease 1 st LHS every 2 R 6 X.
49. Then dec 1 st LHS every R 6 X, ending with 20 sts.
50. Then reverse the shaping: inc 1 st LHS every R 6 X, then every 2 R 6 X, ending with 32 sts.
51. K 32 R.
52. Make one eyelet st as in the fourth st from the right and K 2 R ending COR
53. BO loosely in chain stitch.

#### MAKING I-CORD (for the draw string and cuffs):

54. Using 1 strand of CC and open edge method, CO 4 sts. (See Braided Rug for tips on knitting with few needles.)
55. Using KP #2, K 1 R, ending COL.
56. Lift KP and slide carriage to RHS. Yes, the yarn will be on the LHS.
57. Repeat steps 51 and 52 until you have 8" (measured without weights) of cording for each cuff, 48" for hood drawstring and 42" for lower drawstring.

*For faster knitting of cording, ask about our Magicord Machine.*

#### FINISHING.

Fold 1" of the front edge of the hood to the inside to form the casing and sew down. Pin hood onto neck edge. Sew center back seam of hood. Sew along inside. Sew side and sleeve seams. Let cuffs roll to right side. Sew cording around cuff next to rolled edge. Thread a bodkin or large safety pin with the 48" cord and thread through eyelets and casing of hood. Do the same for the lower edge and draw tightly.

## PATTERN #11. FAMILY PULLOVER.

This pattern is written for unisex sizing. The sleeves are knit from the shoulder edge down after the front and back have been sewn together at the shoulders and the neckband completed. See the schematic at the end of the pattern to check for measurements.

The easiest way to decide which size to make is to measure a sweater you already have that fits you well. Make any adjustments for style (longer or shorter etc). Compare the measurements to the schematic.

**SIZES:** S (M, L)

**FINISHED BUST/CHEST MEASUREMENT:**  
38(42,46)"

**MATERIALS:** Coats & Clark's SUPER SAVER 8-oz acrylic worsted weight yarn:2(3,3) skeins. For the man's version we used Grey #340; for the woman's Raspberry #375.

**GAUGE:** In st st with #3 keyplate: 16st & 23rows = 4". TAKE TIME TO CHECK YOUR GAUGE.

#### BACK:

Cast on 78(86,94)sts with WY using the open edge cast on method (see instruction book page 9) and K 6 R. Break off WY.  
K 70(74,78)rows with MY. Put markers at each end of the row to mark start of armhole. (Use a bit of WY tied to edge sts).  
K 56(58,60) more rows ending COR. Break off MY leaving a 2 ft length.

#### BACK NECK AND SHOULDERS:

**To form back neck:** Place center 30 sts onto spare length of yarn threaded through sts. (or onto a

circular knitting needle) and push the needles back to NWP.

**To form RHS shoulder:** First push all 24(28,32) needles on LHS up to HP making sure the knitting is pushed back against the bed. These needles will not knit. Thread up with WY and K 6 R on RHS needles only.

Break off WY and push needles up to HP making sure the knitting is pushed back against the bed.

**To form LHS shoulder:** Push needles on LHS back to FWP making sure the latches are open. K 6 R in WY as for RHS. Remove work from machine. DO NOT REMOVE HEM.

#### RIBBING:

Starting with COL bring forward 74(80,89)needles to HP using the green cards. With wrong side facing, hang first row of MY onto these needles leaving every third stitch un-hooked. Let weighted hem hang down behind.

Decrease 4(6,5)sts across the row by placing 2 sts on one needle.

Remove the green cards and push every third needle (not carrying a st) back to NWP. K 16 R for ribbing ending COL.

Insert latch tool in bottom sts held on waste yarn and latch up for ribbing. BO in backstitch. Remove hem and WY.

#### FRONT:

Work as for BACK up to the armhole. Place markers at edge to mark armholes. Knit another 36(38,40)rows ending COR.

#### SHAPE NECK:

**To form bottom of neck:** Put center 10 sts onto a length of waste yarn ( or a circular needle ).

**To shape RHS of neck:** Push needles on LHS up to HP making sure knitting is pushed back against the bed. These needles will not knit.

Knitting only on the RHS, dec 1 st neck edge every R 4 X. Then dec 1 st neck edge every other R 6 X ending with 24(28,32)sts remaining.

Knit another 4 rows straight. Break yarn. K 6 R in WY and push needles into HP making sure knitting is pushed back against the bed. Use the small weights to hold down the knitting.

**To shape LHS of neck:** Push needles on LHS into FWP making sure all latches are open and knit exactly like RHS but reverse shaping.

**RIBBING:** Work as BACK.

#### NECKBAND:

Sew one shoulder seam by grafting the edges as shown below or join seam on the machine as in Baby Bunting pattern page 13 steps 33 to 39.

Bring forward 77 needles to HP. With wrong side facing, pick up 77 sts around neck edge, distributed



as follows: 30 sts on waste yarn (or circular needle) from back, 19 sts along side front neck edge, 10 sts on front waste yarn and 18 sts along other side front neck edge.

When picking up sts along side front neck edge you will not pick up a row for every st. Space out the rows evenly and make sure to pick up a whole st not just one of the two loops of the stitch.

Starting COL K 8 R in MY.

To create the rib, insert the latch tool in a stitch 7 rows down, starting the third st from the edge. Unhook the st so it runs down to the latch tool then latch back up the ladder. Hook that st onto the empty needle.

Repeat for every third st round the neck. BO using backstitch.

Sew up remaining shoulder seam (or join on the machine) like the first one and sew neckband seam.

**SLEEVES (TWO ALIKE):** Starting COR bring forward 78(82,86) needles to HP. With wrong side facing you, pick up as many sts from side edge of the body between the armhole markers. Place the center sts at the shoulder seam on either side of the "0" mark on the bed.

Hang the hem and knit the sleeve. As you knit dec 1 st each end every 5 rows 18(19,20) times. You will end with 42(44,46) sts remaining after you have knit 96(102,108) rows ending COR.

Now open fabric guide and remove MY from carriage without breaking it. Thread carriage with WY and K 6 R. Remove work from bed. **DO NOT REMOVE HEM.**

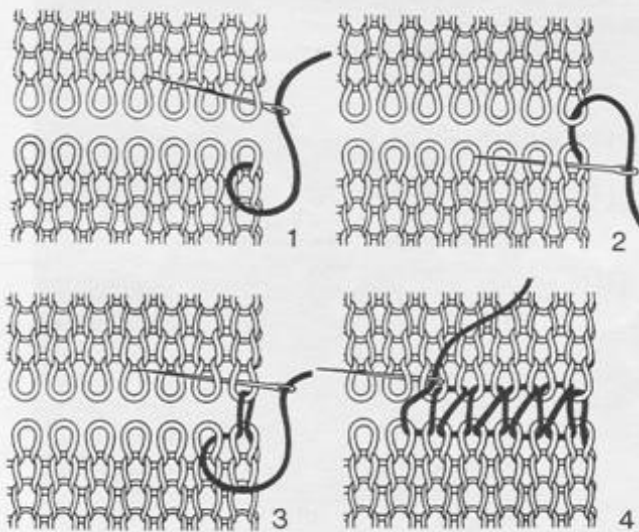

*How to graft a Shoulder Seam.*

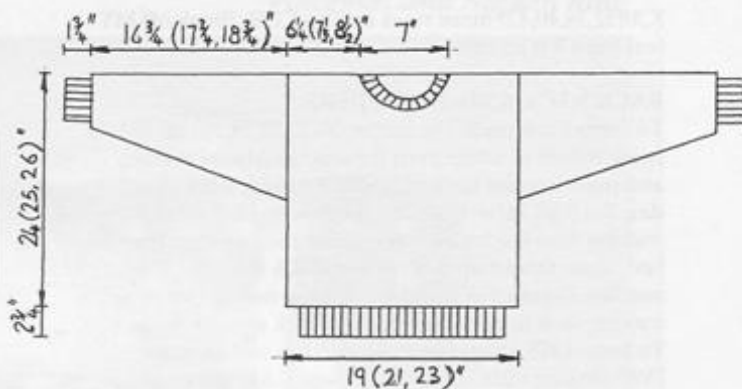

#### CUFF RIBBING:

Bring forward 35(38,41) needles to HP. COL. With wrong side facing hang on sts from last row of MY decreasing 7(6,5) sts evenly across the row. To form ribbing, remove every third st onto a length of waste yarn, and push these empty needles back into NWP. K 10 R. COL. Latch up sts on WY to form ribbing. BO in backstitch. Remove WY.

#### FINISHING:

Sew side seam and sleeve seams.

If you are knitting a design such as Fair Isle or cable on the sleeves then you will need to knit the sleeves from the cuff up, reversing the shaping. Then sew the sleeves to the body of the sweater.

With a length of MY graft the row of MY stitches together before removing the WY. The seam will be invisible.

## PATTERN #12 FAMILY PULLOVERS - CHILDREN'S VERSION

SIZES: 2 (4,6,8,10)

FINISHED CHEST MEASUREMENT:  
23 (26, 28, 32, 34)"

**MATERIALS:** Coats and Clark's SUPER SAVER 8-oz. acrylic worsted weight yarn: 1 (1,1,2,2) skeins. Two spare circular needles. Waste Yarn.

**GAUGE:** In st st with #3 KP: 16 sts and 23 R=4"

#### BACK:

Cast on 48(54,58,66,70) sts with WY using the open edge cast on method ( see instruction book page 9 ) and K 6 R. Break off WY.

K 30(34,42,52,60)R with MY. Put markers at each end of row to mark start of armhole. (Use a bit of waste yarn tied to end sts).

K30(32,36,40,42) more rows ending COR. Break off MY leaving a 2 ft length.

#### BACK NECK AND SHOULDERS:

**To form back neck:** Put center 20(20,22,24,26) sts onto spare length of waste yarn (or onto a circular needle) and push needles back to NWP. **To form RHS shoulder:** Push all 14(16,17,20,22) needles on LHS up to HP making sure the knitting is pushed back against the bed. Then thread up with WY and K 6 R on the RHS needles. Break off WY and push these needles up to HP making sure to push the knitting back against the bed. **To form LHS shoulder:** Push needles on LHS back to FWP making sure latches are open. K 6 R in WY as for RHS. Remove work from machine. **DO NOT REMOVE HEM.**

#### RIBBING:

Starting with COL bring forward 43(49,52,61,64) needles to HP using the green cards. With wrong side facing, hang first row of MY onto these needles leaving every third stitch un-hooked letting the weighted hem hang down behind. Decrease 5(5,6,5,6)sts evenly spaced across the row by placing 2 sts on one needle. Remove the green cards and push every third needle (not carrying a st) back to NWP. K10 (12,12,14,16) R for ribbing ending COL. Insert latch tool in bottom sts held on waste yarn and latch up for ribbing. BO in backstitch. Remove hem and WY.

#### FRONT:

Work as BACK up to armhole. Put markers at edges to mark armholes. K another 14(16,20,24,26) more rows ending COR.

#### SHAPE NECK:

**To form bottom of neck:** Put center 4(6,6,8,8)sts onto a length of waste yarn (or a circular needle). **To shape RHS of neck:** Push needles on LHS up to HP making sure knitting is pushed back to bed. These needles will not knit. Knitting only on the RHS, dec 1 st neck edge every R 4 X. Then dec 1 st neck edge every other row 3(3,4,5,5)times leaving 14 (16,17,20,22) sts remaining. Knit another 6(6,4,2,2)rows giving 30 (32,36,40,42) rows above armhole markers. Break off MY leaving a 2 ft length. K 6 R in WY. Break off WY and push needles up to HP making sure knitting is pushed back to bed. **To shape LHS of neck:** Push needles on LHS into FWP making sure all latches are open and knit exactly like RHS but reverse shaping.

**RIBBING:** Work as BACK.

#### NECKBAND:

Sew one shoulder seam by grafting the edges or join seam on the machine as in the Baby Bunting pattern page 13 steps 33 to 39. Bring forward 53(56,59,65,71)needles to HP. With wrong side facing you, pick up sts around neck edge distributed as follows: 20(20,22,24,26)sts from back

neck, 14(15,15,17,18)sts from side front neck edge, 4(6,6,8,8)sts from front edge, 15(15,16,16,19)sts from other side front neck edge.

When picking up sts along side front neck edge you will not pick up a row for every st. Space out the rows evenly and make sure to pick up a whole st not just one of the two loops of the stitch.

Starting COL K 8 R in MY.

To create the rib, insert the latch tool in a stitch 7 rows down, starting third st in from edge. Un-hook the st so it runs down to the latch tool then latch back up the ladder. Hook that st onto the empty needle. Repeat for every third st round the neck. BO using backstitch.

Sew up remaining shoulder seam (or join on machine) like first one and sew neckband seam.

**SLEEVES (TWO ALIKE):** Starting COR bring forward 44(46,52,58,60)needles to HP.

With wrong side facing you, pick up as many sts from side edge of the body between armhole markers. Place the center sts at the shoulder seam on either side of the "0" mark on the bed.

Hang the hem and knit the sleeve. As you knit dec 1 st each end every 6 R 6(6,8,9,10)times. You will end with 32(34,36,40,40)sts remaining after you have knit 42(46,50,60,64)rows ending COR.

Now open fabric guide and remove MY from carriage without breaking it. Thread carriage with WY and K 6 R. Remove work from bed. **DO NOT REMOVE HEM.**

#### CUFF RIBBING:

Bring forward 29(29,32,35,35)needles to HP. With wrong side facing hang stitches from last row of MY decreasing 3(3,4,5,5)sts evenly across the row. COL. To form ribbing, remove every third st onto a length of waste yarn, and push these empty needles back into NWP.

Knit 8(8,10,10,12)rows. COL. Latch up sts on WY to form ribbing. BO in backstitch. Remove WY.

**FINISHING:** Sew side seam and sleeve seams.

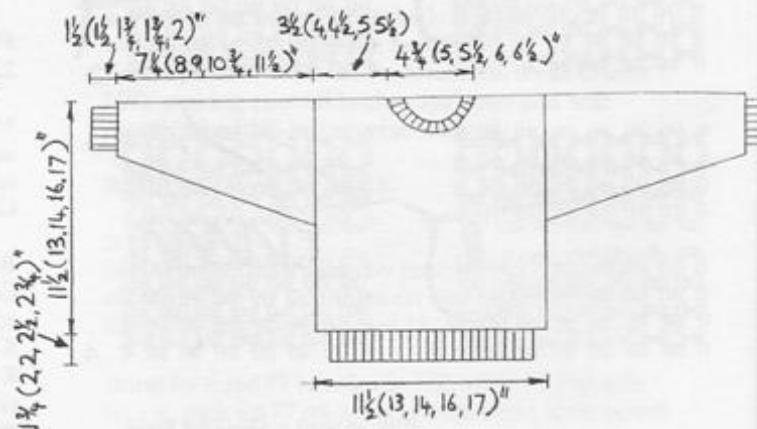

*Placemat and Napkin Ring*



*Braided Rug*

*Baby Bunting*

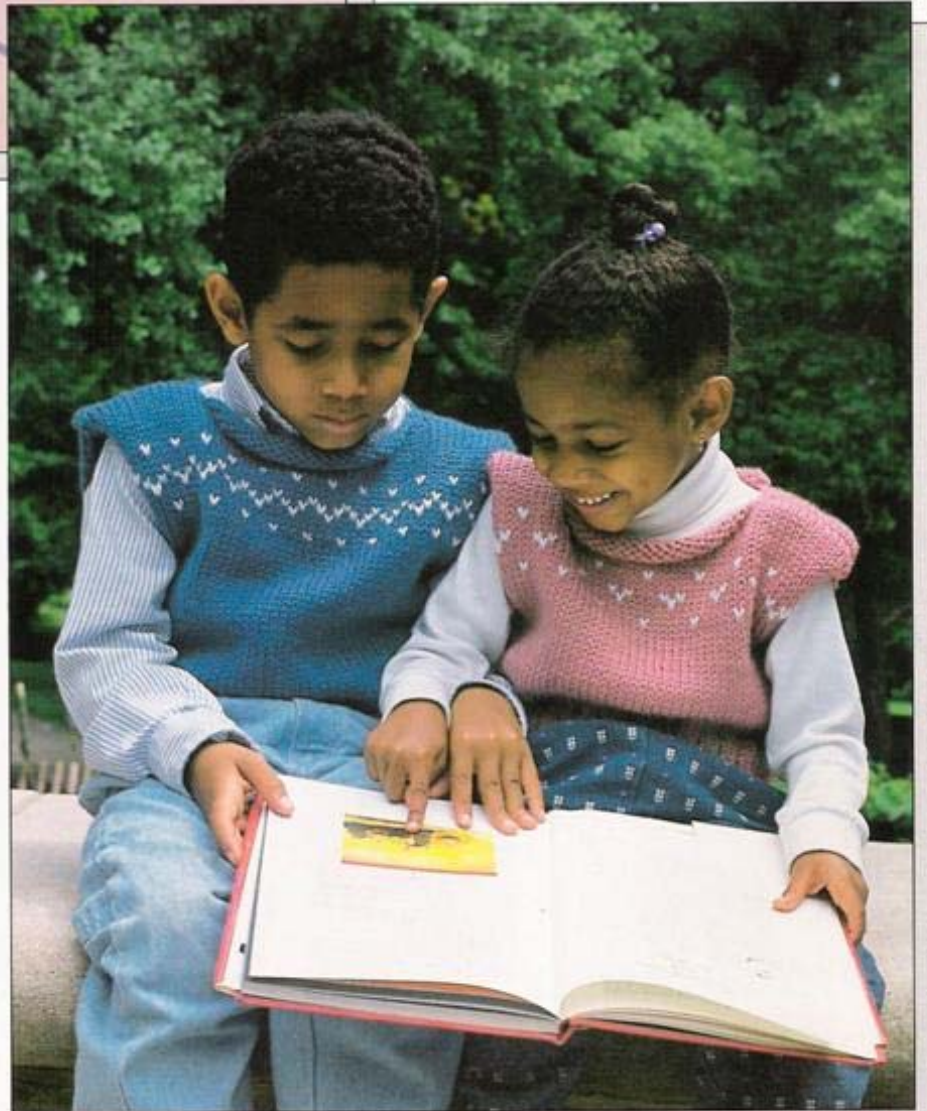
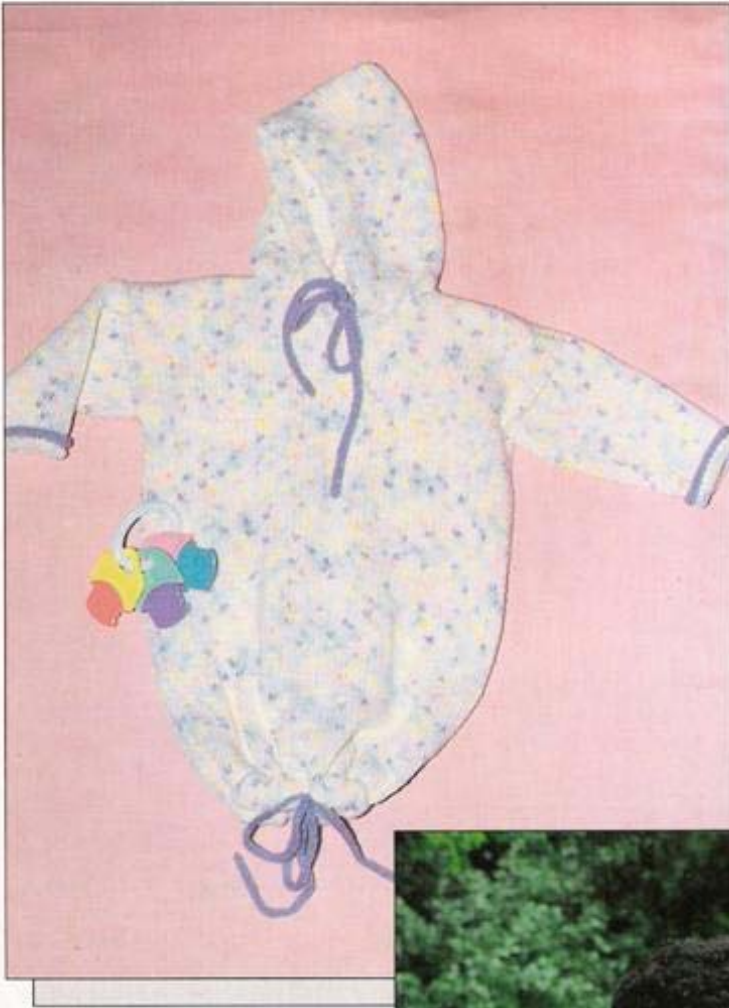

*Childrens Fair Isle Vests*