

KNITTING

MAGAZINE



YARNS

64

Knitking

The Finest From Around the World . . .

HANDSOME Cable yarns from Australia, Great Britain and Germany . . . GORGEOUS Mohairs from Australia . . . BEAUTIFUL Satin-Cotton and Linen-Cotton from Germany . . . plus a NEW, new synthetic, soft and light in weight . . . doesn't pill up . . . yet can be thrown into your washing machine without fear of shrinking or stretching . . . LOVELY Tweed mixtures from England . . . EASY to knit and a JOY to behold.

We import our own yarns and they are sold DIRECT to YOU at BIG SAVINGS!

The BEAUTIFUL PATTERNS in KNITKING MAGAZINE are made with KNITKING YARNS!

Send \$2.00 for LARGE COMPLETE YARN CATALOGUE.
(Refunded on your first \$10.00 order) to:

KNITKING YARNS, Dept. 19
1128 Crenshaw Blvd.
Los Angeles, California 90019

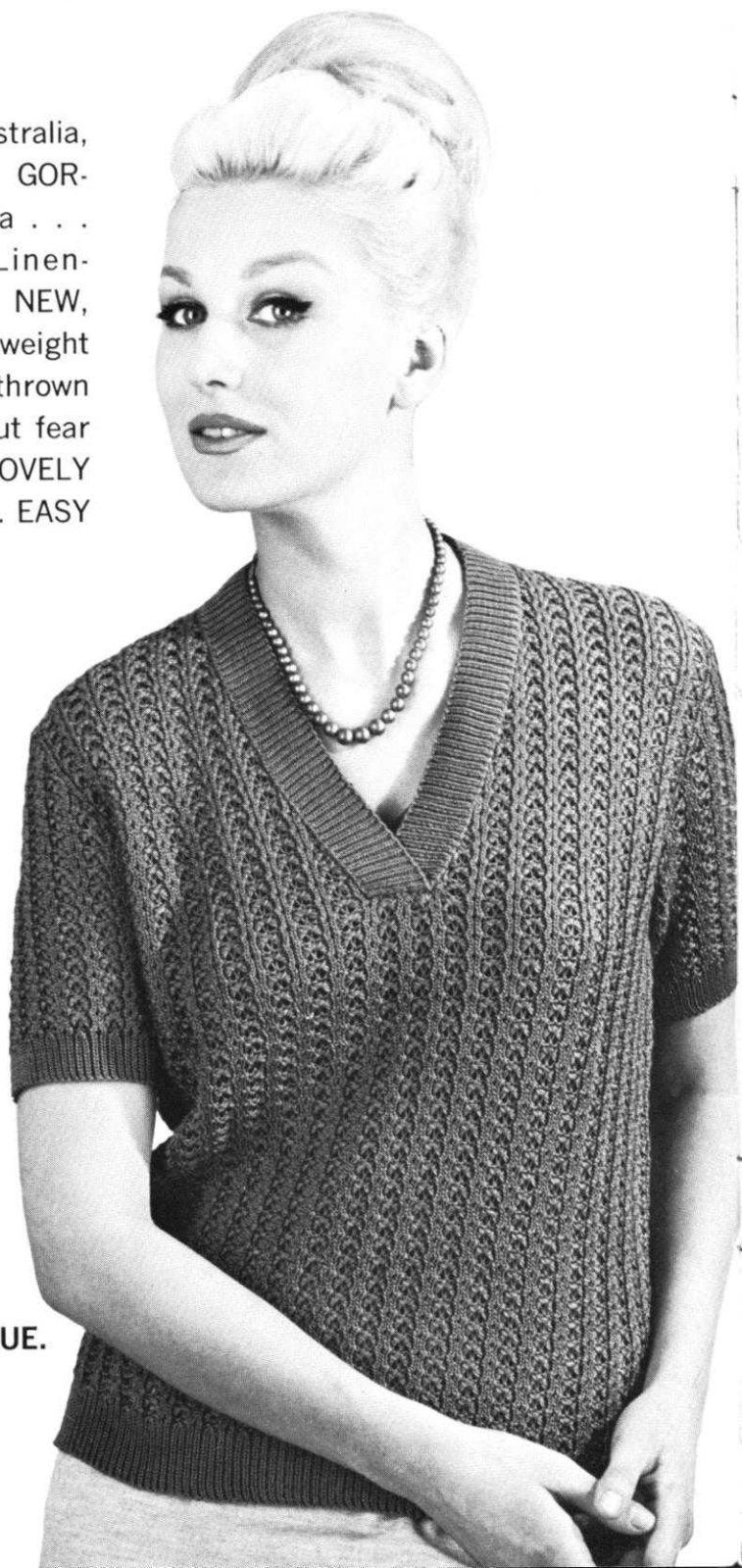

KNITKING

MAGAZINE

Vol. 3, No. 4

March-April, 1967

INDEX

Contents	Pattern No.	Page No.
Woman's Pullover	DP 7418.....	18
Woman's Dress	DK 7423.....	18
Woman's Dress	DK 7421.....	19
Woman's Pullover	DP 7422.....	20
Woman's Pullover	DP 7420.....	21
Woman's Jacket	DP 7424.....	21
Woman's Pullover.....	DP 7425.....	23
Woman's Jacket	DP 7419.....	24
Woman's Blouse	DP 7426.....	25
Man's Shirt	HP 3458.....	26
Man's Shirt	HP 3457.....	27
Man's Cardigan	HP 3443.....	28
Girl's Cardigan	MK 4799.....	29
Child's Pullover	KK 4798.....	30
Boy's Pullover	KK 4797.....	30
Girl's Cardigan	MK 4711.....	31
Practical Knitting Hints		32



DP 7418—OUR COVER MODEL

Beginning of Spring! So many lovely garments to knit from our new Spring issue . . . start with our Cover Model . . . a pullover knitted in an eyelet design. Just the thing to wear under a suit now and later without a jacket. If you have never knitted an eyelet design, this is not as difficult as you think . . . so give it a whirl and make a sample swatch following the chart first, and see what we mean. Size 12/14. See page 18.

Publisher: Henry J. Atkin, 1128 Crenshaw Blvd., Los Angeles, Calif. 90019, Telephone: WEbster 8-2079. Published bi-monthly. Subscriptions: USA—\$6.00 annually, single copies \$1.50; Canada—\$7.00; other parts of the world—\$10.00. The entire contents of KNITKING MAGAZINE are copyright and must not be reproduced in any shape or form without the express permission, in writing, of the publisher.

Printed by: George Rice & Sons, Los Angeles, Calif.



Letter from the Publisher

It is obvious that knits are becoming even more popular for all types of garments and for people of all ages. We are certain that once individuals become accustomed to wearing comfortable good fitting knits, knitted garments will become one of the most essential parts of their wardrobe.

A few years ago hand knitting was devoted almost exclusively to sports wear in the form of pullovers and cardigans plus the occasional knitting of an afghan or a stole. Today, however, practically every type of garment can be and is knitted. In addition to all types of sportswear, knits are high fashion. Top quality wools are gorgeous, synthetics that can easily be washed and dried are extremely popular and as the few small disadvantages associated with some synthetics are overcome, they will become even more so. Metallic knits (we introduced some in the January-February issue of Knitking Magazine) are stylish, extremely popular and suitable for day or evening wear.

The introduction of Knitking automatic knitters and other good brands of knitting machines to the American market made it possible for users to knit with very fine yarns and crochet cottons and produce in hours instead of months, superfine light weight garments in plain or fancy lacy stitches. To be a proud owner of a Knitking knitter is to be able to produce for yourself and your family all the knits your heart desires and in any of the multitude of beautiful yarns available.

In the few short years since Knitking introduced the first automatic hand knitter to the American market, our design engineers have continued to strive for complete automation and yet retain simplicity of operation. There is no doubt that nothing comparable is on the market today to the all new Push Button Knitking with Coordinated Ribber. It is the only automatic knitter that operates with cams (just like your sewing machine) which select for you an absolutely limitless number of fancy stitches. To select one fancy stitch on other machines, you push and pull as many as eight controls, repeating the movements every time you need to duplicate the stitch. The new Knitking has an automatic resetting mechanism that resets the controls so that all you need to do is push one button to reproduce the identical stitch. Knitking also knits yarn impossible on other machines, yarns such as looped mohair, thick and thin yarns, metallics and ribbons, etc., etc.

If you would like further information plus one of the new beautiful color brochures and an appraisal of the trade in value of your present machine, just drop us a line.

DK 7423

Treat yourself to this dreamy dress. Our model is knitted in our Fine Dralon. The holding position design is worn on the purl side. It is quickly knitted as well as easy to do. Knit it today, wear it tomorrow. Size 12/14 and 16/18. See page 18.





DK 7421

Blend your three favorite colors for this sheath dress knitted in stockinette stitch. The bands of color in different widths are used for eye appeal and are very much in fashion. Why not knit two — one without the stripes if you wish. Size 12/14. See page 19.



DP 7422

Go Pretty! Wherever you go, lace has a place in your travel wardrobe. We knit our model pullover of lovely KNITKING Satin Cotton in a simple holding position design. The arm edges and flattering oval neckline are trimmed in stockinette stitch. Size 14/16. See page 20.

DP 7420

Another soft and flattering pullover, this time in a textured yarn. The bottom, arm and neck edges are trimmed in a white braid which you may buy in any department store, or if you like, you can knit your own trim. Size 10/12 and 14/16. See page 21.





DP 7424 and DP 7425

DOUBLE BEAUTY!

An elegantly patterned jacket for that special little cover up . . . May be worn with DP 7425 or with almost any dress. The jacket is knitted in a holding position design and the very fashionable shell is a rib design. We know you'll want both of them. Size 10/12 and 14/16. See pages 21 and 23.





DP 7419

SLIM and TRIM!

Vertical stripes for an up to the minute fashion and a lovely jacket to boot. We chose yellow and blue for our model and it could be knitted in pastel shades as well. A very easy holding position design. Order enough yarn in one color to knit a skirt . . . Size 14/16 and 20/22. See page 24.

DP 7426 →

Another lovely striped pattern, this one especially for our larger sized friends . . . a slimming button down the front blouse knitted in blue and white. Do knit a skirt in one of the colors for a complete spring outfit. Size 14/16 and 18/20. See page 25.



poli

HP 3458

He'll believe you are an expert when you hand him this completed shirt. So very simple to knit, you will surprise even yourself. Make several in different colors. The stripes on collar and pocket are knitted in 2 contrasting colors. Size 42/44. See page 26.

BEGINNERS

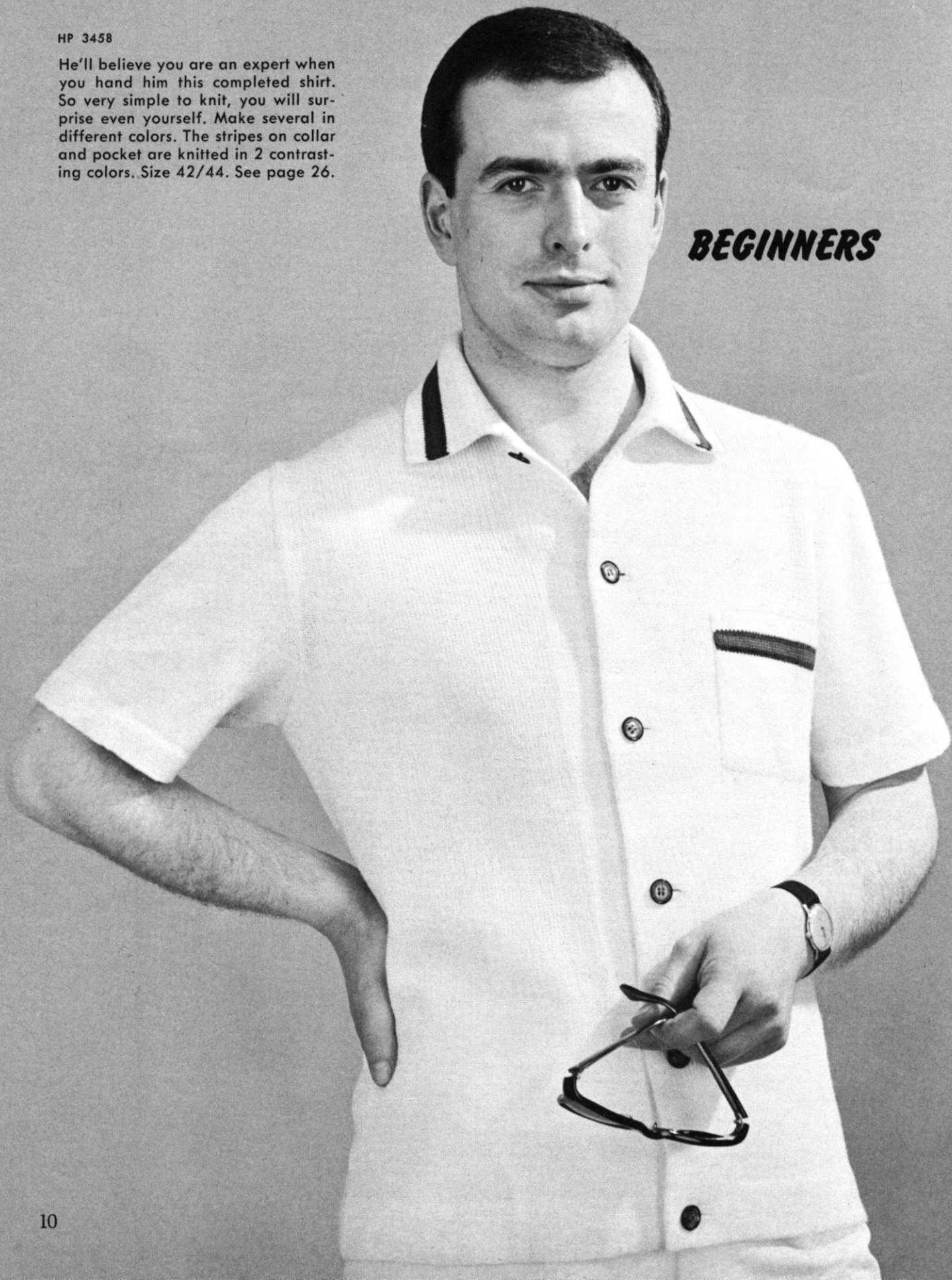

HP 3457

SPRING and SUMMER COMFORT

Treat the man in your life to this easy to knit long sleeved shirt and be sure to knit it in KNITKING Linen Cotton. All the important details add an expensive look. Size 40/42. See page 27.

PATTERNS . . .





HP 3443

No trick to knit and finish this neatly styled man's cardigan. It is knitted over every other needle in a heavy weight yarn. Use scraps of contrast color to add the saddle stitching around the neckline and pockets. Size 40/42 and 44/46. See page 28.

MK 4799 →

A young girl never has enough basic cardigans . . . and this one with its raglan sleeves will be happily worn. You may also dress it up a bit with embroidered or crochet flowers for a party look. Sizes 10/11 years and 12/13 years. See page 29.





KK 4798

FUN TIME!

For a small child A three colored pullover with raglan sleeves that has an interesting striped pattern knitted in a holding position design. For the 5 to 6 year old. See page 30.



KK 4797

BOY TIME!

A small boy (just like his Dad) does appreciate something made especially for him . . . so knit him a smart pullover in a holding position design. The ribbing at neck and edge of sleeve is in two contrasting colors. Size 7 to 8 years. See page 30.



MK 4711

On wheel or foot, she travels in style wearing this lovely cardigan. The holding position design is one of our simple ones and lovely to look at. Size 7 to 8 years. See page 31.



ACCESSORIES

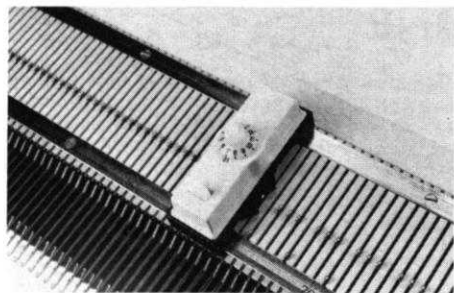

Automatic Needle Selector fits all model Knitkings prior to the pushbutton

\$6.95
Shipping 20¢

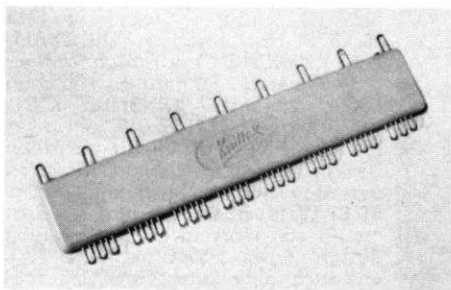

Adjustable Selector

\$2.95
Shipping 12¢

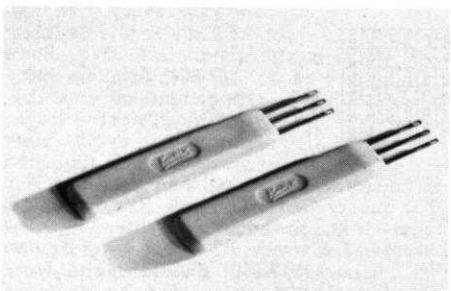

Treble Transfer Tools

\$1.50
Shipping 10¢

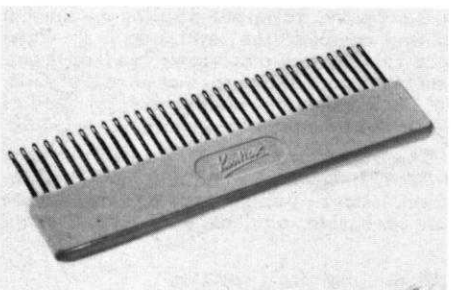

Multi-transfer Tool

\$2.75
Shipping 12¢

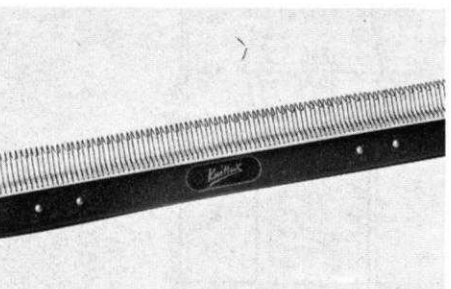

Reversing Bar

\$16.95
Shipping \$1.50

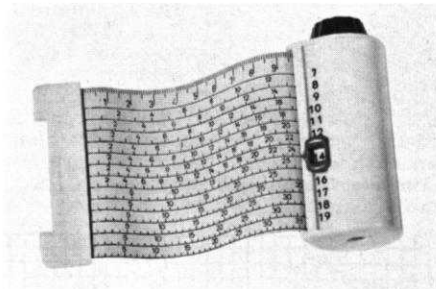

Converta Tape

\$5.95
Shipping 15¢

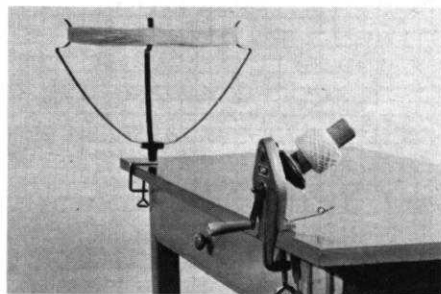

Yarn Winder with Skein Holder

\$14.95
Shipping \$1.00



\$24.95
Shipping \$1.00



The perfect tool for automatic selection of Jacquard and ski-sweater designs. Over 125 patterns available.

KNITTING INSTRUCTIONS

OUR COVER MODEL WOMAN'S PULLOVER, No. DP 7418



SIZE: 12/14. **MATERIAL:** 9 oz. blue. **FOR EXAMPLE:** KNITKING Subita 2 x 3. Bearbrand Deluxe sock and sport. Diamond Velvete. **TENSION:** KNITKING 4 or 5. **GAUGE:** 16 sts. 2", 29 rows 2". **PATTERN:** Stockinette Stitch with eyelet design according to chart. Edging: Stockinette Stitch.

BACK: (Figure II). Cast on 147 sts. Rows 1-23: Stockinette Stitch. To make the hem, put the cast on sts. back on the machine. Row 24: Work the sts. together with Tension 5 (6). Continue in pattern stitch. Rows 25-232: Increase 1 st. on each side after Row 82 and again on each side every 24th row 5 x. (159 sts.). Rows 233-258: Armhole Shaping. Bind off 3 sts. beginning next 2 rows

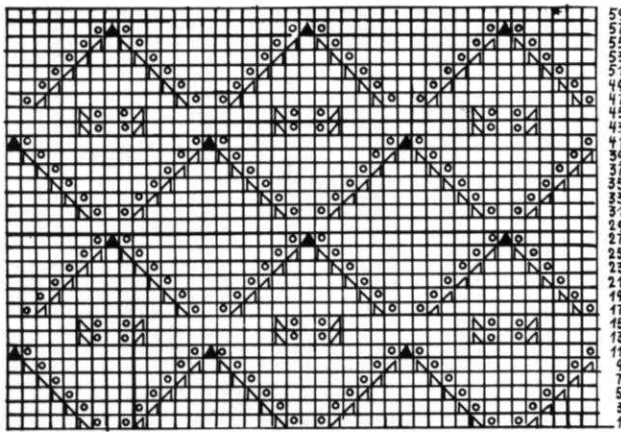

See Practical Knitting Hints, Page 32



8th row 2 x, and every 6th row 2 x. (141 sts.). Rows 327-354: **Shoulder and Neck Shaping.** On each shoulder side of every other row decrease 1 st. 3 x, bind off 2 sts. 5 x, 3 sts. 6 x, and 4 sts. 1 x. **AT THE SAME TIME,** for the neck shaping, after Row 336 bind off the 25 center sts. with a separate yarn, put needles on the left into holding position and complete the right side first. When Cam box is on neck side, (every other row) bind off 4 sts. 2 x, 3 sts. 3 x, and 2 sts. 3 x. Put needles on the left into working position, row counter back to 336 and complete left side.

FRONT: (Figure I). Knit the front same as the back; however, for the neck shaping, after Row 314 bind off the 21 center sts. with a separate yarn, put all needles on the left into holding position and complete the right side. When Cam box is on neck side, (every other row) bind off 4 sts. 2 x, 3 sts. 1 x, 2 sts. 4 x, decrease 1 st. 3 x; then decrease 1 st. on every 4th row 3 x. Put row counter back to 314, all needles in work and complete the left side.

NECK EDGING: Cast on 164 sts. Knit 8 rows with Tension 4, 8 rows with Tension 3, and 8 rows with Tension 4. Bind off all sts. using Crochet method.

ARMHOLE EDGING: (Make 2) Cast on 115 sts. Knit 8 rows with Tension 4, 8 rows with Tension 3, and 8 rows with Tension 4, decreasing 1 st. on each side after Rows 2, 6, and 10, and increasing 1 st. on each side after Rows 14, 18, and 22. Bind off all sts. using Crochet method.

FINISHING: Join front and back sections at side and shoulder seams. Sew the ends of the neck edging and arm edging together, so that they are circular. Fold the neck edging around the neckline of the pullover and attach. Do the same for arm edgings.

WOMAN'S DRESS, No. DK 7423



SIZES: 12/14 and 16/18. **MATERIAL:** Size 12/14 12 1/4 oz. turquoise. Size 16/18 14 oz. turquoise. **FOR EXAMPLE:** KNITKING Fine Dralon, Columbia Minerva Fingering, Diamond Laine Ecossaise. **TENSION:** KNITKING 3 or 4. **GAUGE:** 16 sts. 2", 44 rows 2". **PATTERN:** Holding Position Design according to chart. Worn on purl side. **Edging:** Stockinette Stitch.

SIZE: 12/14. **BACK:** (Figure II). Cast on 161 sts. Work in holding position design. Rows 1-590: Decrease 1 st. on each side after Row 432 and again on each side every 16th row 6 x, every 12th row 3 x, and every 8th row 3 x. (135 sts.). Rows 591-616: Work even. Rows 617-766: On each side increase 1 st. after Row 616 and again every 12th row

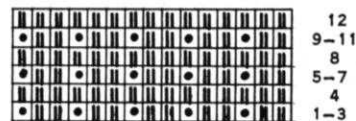

3 x and every 14th row 7 x. (154 sts.). Rows 767-808: **Armhole Shaping.** Bind off 4 sts. beginning next 2 rows; then on every other row on each side bind

off 3 sts. 1 x, 2 sts. 2 x, decrease 1 st. 2x; then decrease 1 st. on every 4th row 3 x and on every 6th row 3 x. (119 sts.). Rows 809-916: Increase 1 st. on each side after Row 854 and again every 10th row 2 x, every 8th row 3 x, and every 6th row 2 x. (135 sts.). Rows 917-950: **Shoulder and Neck Shaping.** On each shoulder side of every other row decrease 1 st. 8 x, bind off 2 sts. 7 x, and 3 sts. 3 x. **AT THE SAME TIME,** for the neck shaping, after Row 924 bind off the 19 center sts. with a separate yarn, put needles on the left in holding position and complete the right side first. When Cam box is on neck side (every other row) bind off 4 sts. 1 x, 3 sts. 4 x, 2 sts. 4 x, and decrease 1 st. 3 x. Put Cam Box on the left side. Put row counter back to 924, all needles in work and complete the left side.

FRONT: (Figure I). The front is worked the same as the back to Row 766. Rows 767-784: Work even. Rows 785-826: **Armhole Shaping.** Bind off 4 sts. beginning next 2 rows; then on every other row, on each side, bind off 3 sts. 1 x, 2 sts. 2

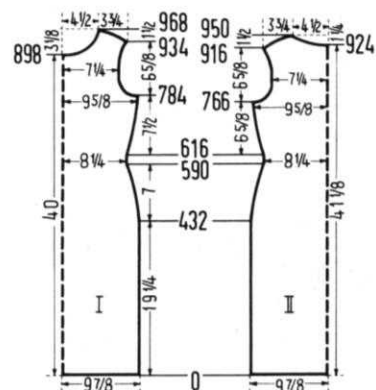

x, decrease 1 st. 2 x; then decrease 1 st. every 4th row 3 x and every 6th row 3 x. (119 sts.) Rows **827-898**: Increase 1 st. on each side after Row **872** and again every 10th row 2 x. Rows **899-968**: **Neck, Armhole, and Shoulder Shaping**. For the neck shaping bind off the 19 center sts., and work one side at a time as you did on back. On neck side on every other row bind off 4 sts. 1 x, 3 sts. 2 x, 2 sts. 3 x, decrease 1 st. 4 x, then decrease 1 st. every 4th row 4 x and every 6th row 3 x. **AT THE SAME TIME**, for the **armhole shaping**, on arm side increase 1 st. after row 900 and again every 8th row 2 x and every 6th row 2 x; then after Row 934, for the **shoulder shaping**, on every other row decrease 1 st. 8 x, bind off 2 sts. 7 x and 3 sts. 3 x. Put Row Counter back to 898, all needles in work and complete other side.

NECK EDGING: Cast on 164 sts. Stockinette: 5 rows with Tension 3, 5 rows with Tension 2, 12 rows with Tension 1, 5 rows with Tension 2 and 5 rows with Tension 3. Then bind off all sts.

ARMHOLE SHAPING: (Make 2). Cast on 123 sts. Stockinette: 5 rows with Tension 3, 5 rows with Tension 2, 12 rows with Tension 1, 5 rows with Tension 2, and 5 rows with Tension 3, decreasing 1 st. on each side after Rows 4, 8, 12, and increasing 1 st. on each side after Rows 20, 24, and 28. Bind off all sts.

BELT: Cast on 17 sts. Work 600 rows K. 1, P. 1 Ribbing with Tension 2 and bind off all sts.

FINISHING: Join front and back sections at side and shoulder seams, easing in the fullness at bustline of front section. Make a 2" hem in the bottom of the dress. Sew the ends of the neck and armhole edgings together so that they are circular, fold around the dress neckline and armholes and attach.

SIZE: 16/18. BACK: (Figure II). Cast on 179 sts. Work in Holding Position design. Rows **1-598**: Decrease 1 st. on each side after Row **440** and again every 16th row 6 x, every 12th row 3 x, and every 8th row 3 x. (153 sts.). Rows **599-624**: Work even. Rows **625-782**: Increase 1 st. on each side after Row 624 and again every 14th row 10 x. (175 sts.). Rows **783-822**: **Armhole Shaping**. Bind off 5 sts. beginning next 2 rows then on every other row on each side bind off 3 sts. 2 x, 2 sts. 2 x, decrease 1 st. 3 x, then decrease 1 st. every 4th row 3 x and every 6th row 2 x. (129 sts.). Rows **823-940**: Increase 1 st. on each side after Row **878** and again every 10th row 2 x, every 8th row 3 x, and every 6th row 2 x. (145 sts.). Rows **941-974**: **Shoulder and Neck Shaping**. On each shoulder side of every other row decrease 1 st. 7 x, bind off 2 sts. 6 x, and 3 sts. 5 x. **AT THE SAME TIME**, for the **neck shaping**, after Row 948 bind off the 19 center sts. with a separate yarn, put needles on the left into Holding position and complete the right side. When Cam box is on neck side (every other row) bind off 4 sts. 2 x, 3 sts. 3 x, 2 sts. 5 x, and decrease 1 st. 2 x. Put Cam box on the left, row counter back to 948 and complete the left side.

FRONT: (Figure 1). The front is worked the same as the back to Row 782. Rows **783-800**: Work even. Rows **801-840**: **Armhole Shaping**. Bind off 5 sts. beginning next 2 rows then on every other row, on each side, bind off 3 sts.

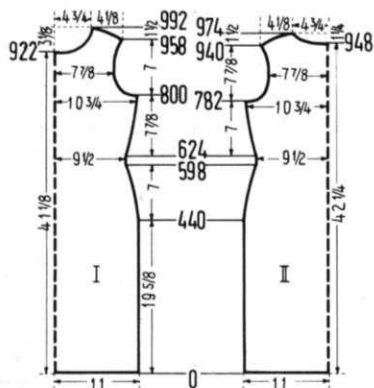

2 x, 2 sts. 2 x, decrease 1 st. 3 x; then decrease 1 st. every 4th row 3 x and every 6th row 2 x. (129 sts.). Rows **841-922**: Increase 1 st. on each side after Row **896** and again every 10th row 2 x. Rows **923-992**: **Neck, Armhole and Shoulder Shaping**. Bind off the 19 center sts. for neck and complete one side as you did on back. When Cam box is on neck side (on every other row) bind off 4 sts. 1 x, 3 sts. 3 x, 2 sts. 3 x, decrease 1 st. 3 x; then decrease 1 st. every 4th row 3 x and every 6th row 4 x. **AT THE SAME TIME**, for the **armhole shaping**, on arm side increase 1 st. after Row 924 and again every 8th row 2 x and every 6th row 2 x; and after Row **958**, for the **shoulder shaping**, on shoulder side of every other row decrease 1 st. 7 x, bind off 2 sts. 6 x and 3 sts. 5 x. Put row counter back to 922, all needles in work and complete other side.

NECK EDGING: Cast on 175 sts. Knit in stockinette st. 5 rows with Tension 3, 5 rows with Tension 2, 12 rows with Tension 1, 5 rows with Tension 2, and 5 rows with Tension 3. Bind off all sts.

ARMHOLE EDGING: (Make 2). Cast on 135 sts. Knit in Stockinette st. 5 rows with Tension 3, 5 rows with Tension 2, 12 rows with Tension 1, 5 rows with Tension 2, and 5 rows with Tension 3; decreasing 1 st. on each side after Rows 4, 8, and 12, and increasing 1 st. on each side after Rows 20, 24, and 28. Bind off all sts.

BELT: Cast on 17 sts. Work 700 rows K. 1, P. 1. Ribbing with Tension 2 and bind off all sts.

FINISHING: Follow directions for Size 12/14.

WOMAN'S DRESS, No. DK 7421



SIZE: 12/14. MATERIAL: 7 oz. turquoise, 7 oz. beige, 7 oz. light red. FOR EXAMPLE: KNITTING Subita 2 x 3 Spinnerin Nylaine Fingering Redheart Nylon and wool sport. **TENSION: KNITTING** 5 or 6. **GAUGE: 18 sts. 2", 23 rows 2". PATTERN: Stockinette Stitch.**

BACK: (Figure II). Cast on 170 sts. with turquoise. Rows **1-150**: Increase 1 st. on each side after Row 52 and again every 24th row 4 x. (180 sts.). Rows **151-166**: Work even: Now work 2 rows beige, 6 rows turquoise, 4 rows beige, 4 rows turquoise, 6 rows beige, 2 rows turquoise, and after Row 190 continue work with beige to Row 226. Rows **227-308**: Decrease 1 st. on each side and again every 10th row 2 x, every 8th row 3 x, every 6th row 4 x, and every 4th row 3 x. **AT THE SAME TIME**, for the **DARTS**, decrease 2 sts. on each side after Row 256 and again every 14th row 2 x and every 12th row 2 x. To do this, on each side put the 54th and 56th sts. on the 55th needle and move the sts. over to fill the empty needles. The next decrease lies directly above. (134 sts.). Rows **309-322**: Work even. Rows **323-410**: Increase 1 st. on each side after Row 322 and again every 8th row 10 x. **AT THE SAME TIME**, for the **DARTS**, increase 2 sts. each side after Row 322 and again every 12th row 2 x and every 14th row 2 x. The increases lie directly above the decreases. After Row 332 work 2 rows red, 6 rows beige, 4 rows red, 4 rows beige, 6 rows red, 2 rows beige, and then continue with red. (176 sts.). Rows **411-427**: **Armhole Shaping**. Bind off 5 sts. beginning next 2 rows then on each side of every other row bind off 4 sts. 1 x, 3 sts. 2 x, 2 sts. 2 x, and decrease 1 st. 2 x. (134 sts.). Now, on the right side, put 66 needles in holding position and continue working on the left section. Rows **428-483**: For the facing for the back opening, on the right side cast on 3 sts. after Row 428. To do this, put 3 sts. from the right section onto a double pointed needle or contrast yarn. At the armhole edge increase 1 st. after Row 451, again on the 10th row 1 x, on the 8th row 1 x, on the 6th row 1 x, and on the 4th row 1 x. Rows **484-501**: **Shoulder and Neck Shaping**. On shoulder side, on every other row bind off 3 sts. 4 x, 4 sts. 2 x, 7 sts. 2 x, and 8 sts. 2 x. **AT THE SAME TIME**, for the **neck shaping**, bind off 10 sts. after Row 492, then on every other row bind off 5 sts. 1 x, 4 sts. 1 x, and 3 sts. 2 x. Now put the cam box on the right

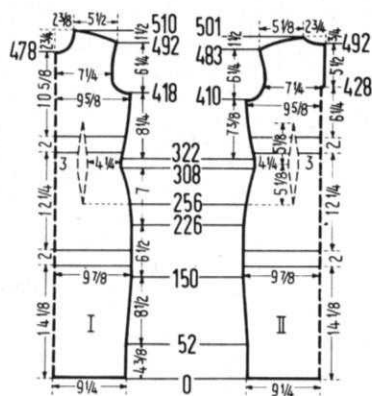

side, and turn the row counter back to 427. Bring all the needles into working position, put the sts. from the double pointed needle back onto the machine, and work the right section.

FRONT: (Figure I). The front is worked the same as the back to Row 410. Rows 411-418: Work even. Rows 419-436: **Armhole Shaping:** Bind off 5 sts. beginning next 2 rows then on each side on every other row bind off 4 sts. 1 x, 3 sts. 2 x, 2 sts. 2 x, and decrease 1 st. 2 x. (134 sts.). Rows 437-478: Increase 1 st. on each side after Rows 460 and 470. Rows 479-510: **Neck, Armhole and Shoulder Shaping.** Bind off the 14 center sts. for neck with a separate yarn. Put needles on the left into holding position and complete the right side first. When Cam box is on neck side (every other row) bind off 3 sts. 2 x, 2 sts. 2 x, decrease 1 st. 2 x; then decrease 1 st. every 4th row 3 x. **AT THE SAME TIME,** for the **armhole shaping,** on arm side increase 1 st. after Row 478 and again on the 6th row 1 x and on the 4th row 1 x; and after Row 492, for the **shoulder shaping,** on shoulder side of every other row bind off 3 sts. 4 x, 4 sts. 2 x, 7 sts. 2 x, and 8 sts. 2 x. Put Cam box on the left side. All needles in work, row counter back to 478 and complete the left side.

FACING FOR NECK OPENING: Cast on 107 sts. with red. Stockinette Stitch: 2 rows with Tension 6, 2 rows with Tension 5, and 4 rows with Tension 4. Bind off all sts.

FACINGS FOR ARMHOLE OPENINGS: (Make 2). Cast on 113 sts. with red. Stockinette Stitch: 2 rows with Tension 6, 2 rows with Tension 5, and 4 rows with Tension 4; increasing 1 st. on each side after Rows 3 and 6. Bind off all sts.

FINISHING: Join front and back sections at side and shoulder seams, easing in the fullness at bustline of front section. Make a hem 4 sts. wide around back neck opening. Sew facings to neck and armhole openings. Sew in zipper. Make a 1 1/2" hem around bottom of dress.

CANADIAN READERS

Please note that KNITKING dealers based in the U.S.A. are unable to sell machines and accessories to residents of Canada. They are also unable to sell parts and service. Would all Canadian readers please contact any of the following appointed KNITKING dealers.

Knittax Handknitting Machines
Sales and Service Reg'd
H. Cieslewicz
3059 Estelle, Fabreville, P.Q.

Easy Knit of Canada Ltd.
272 Yonge Street
Toronto 1, Ontario

Winnipeg Knitting Machines Ltd.
202 Confederation Building
457 Main St., Winnipeg 2, Manitoba

Knit-King Agency
Hand Knitting Machines
Mrs. M. Gross
5316 - 90th Ave., Edmonton, Alberta

Kay Hamilton Enterprises
5724 - 110th Street, Edmonton, Alberta, Canada

WOMAN'S PULLOVER, No. DP 7422



SIZE: 14/16. **MATERIAL:** 14 oz. light blue. **FOR EXAMPLE:** KNITKING Satin Cotton. **TENSION:** KNITKING Pattern Stitch 7 or 8; Stockinette Stitch 6 or 7. **GAUGE:** Pattern Stitch 14 sts. 2", 36 rows 2"; Stockinette Stitch 14 sts. 2", 20 rows 2". The non-working-position sts. of the pattern stitch are counted in the gauge and in the directions. **PATTERN:** Holding Position Design according to chart. Worn on purl side. Edging: Stockinette Stitch.

BACK: (Figure II). Cast on 146 sts., preferably using the reversing bar. Rows 1-20: Work in Stockinette Stitch with Tension 6 (7). To make the hem, put the cast on sts. back on the machine so that they hang in the needle latches.

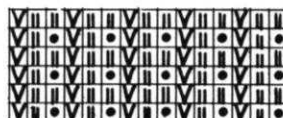

12 Pull up the right cam knob and work 2 rows without yarn. Push in the cam knob. Turn the Row Counter back to 20. Now put the 3rd, 6th, 9th,

12th, etc. sts. on the neighboring needle to the left, and put the empty needles out of operation. Put the 1st, 3rd, 5th, 7th, etc. of those needles in working position into holding position and continue in holding position design with Tension 7 (8). Rows 21-258: Work even. Rows 259-292: **Armhole Shaping.** Bind off 4 sts. on each side; then on each side on every 4th row bind off 3 sts. 2 x, 2 sts. 1 x, decrease 1 st. 2 x and decrease 1 st. every 6th row 2 x. (114 sts.). Rows 293-374: Increase 1 st. on each side after Row 320 and again

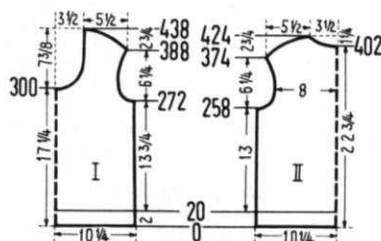

every 10th row 2 x, every 8th row 2 x, and every 6th row 2 x. (128 sts.). Rows 375-424: **Shoulder and Neck Shaping.** For the shoulder shaping, decrease 1 st. on each side after Row 374, again on the 6th row 1 x, on every 4th row 3 x, and on every other row 5 x; then on each side of every other row bind off 2 sts. 4 x and 3 sts. 7 x. **AT THE SAME TIME,** for the **neck shaping,** after Row 402 bind off the 16 center sts., with a separate yarn, put needles on the left into Holding position and complete the right side first. When Cam box is on neck side, on every 4th row bind off 5 sts. 1 x, 4 sts. 1 x, 3 sts. 2 x and 2 sts. 1 x. Bring all needles into working position, Row counter back to 402 and complete the left side.

FRONT: (Figure I). The front is worked the same as the back to Row 258. Rows 259-272: Work even. Rows 273-300: **Armhole Shaping.** Bind off 4 sts. beginning next 2 rows, then on every 4th row, on each side, bind off 3 sts. 2 x, 2 sts. 1 x, decrease 1 st. 2 x; then decrease 1 st. on the 6th row 1 x. Rows 301-438: **Neck, Armhole, and Shoulder Shaping.** For the neck shaping, bind off the 14 center sts. with a separate yarn, put needles on the left into holding position, and complete the right side first. When Cam box is on neck side on every 4th row bind off 4 sts. 1 x, 3 sts. 1 x, 2 sts. 1 x, decrease 1 st. 3 x, and then decrease 1 st. every 6th row 3 x and every 8th row 3 x. **AT THE SAME TIME,** for the **armhole shaping,** decrease 1 st. on arm side after Row 304, and then increase 1 st. on arm side after Row 334, again every 10th row 2 x, every 8th row 2 x, and every 6th row 2 x. For the **shoulder shaping,** on shoulder side decrease 1 st. after Row 388, again on the 6th row 1 x, every 4th row 3 x, and every other row

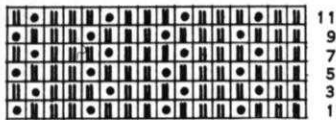

retractor button to retract needles automatically. This pattern must be pulled and stretched in all directions to get it into shape, so it is recommended that after every 100 rows, while

the garment is still on the machine, you pull and stretch it in all directions. Edging: Stockinette.

SIZE: 10/12. BACK: (Figure II). Cast on 110 sts. Rows 1-26: Work in Stockinette Stitch with Tension 6 (7). To make the hem, put the cast on sts. back on the machine, place the gate cam release lever at the needle heels, and continue in Holding Position Design with Tension 5 (6). Rows 27-250: Work even. Rows 251-284: **Armhole Shaping.** Bind off 4 sts. beginning next 2 rows then on each side, on every 4th row, bind off 3 sts. 1 x, 2 sts. 1 x, decrease 1 st. 2 x and then decrease 1 st. every 8th row 2 x. (84 sts.). Rows 285-380: Work even. Rows 381-408: **Shoulder and Neck Shaping.** On each shoulder side of every other row decrease 1 st. 6 x and bind off 2 sts. 9 x. **AT THE SAME TIME,** for the neck shaping, after Row 394 bind off the 14 center sts. with a separate yarn, put the needles on the left into holding position and complete the right side. When Cam box is on neck side (every other row) bind off 3 sts. 1 x, 2 sts. 3 x, and decrease 1 st. 2 x. Put all needles in work, row counter back to 394 and complete the left side.

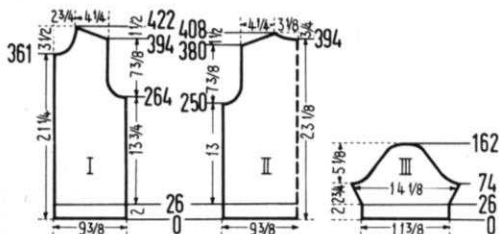

FRONT: (Figure I). Cast on 53 sts. Rows 1-26: Work in Stockinette Stitch with Tension 6 (7). To make the hem, put the cast on sts. back on the machine, place the gate cam release lever at the needle heels and continue in holding position design with Tension 5 (6). Rows 27-264: Work even. Rows 265-298: **Armhole Shaping.** For the armhole Shaping, bind off 4 sts.; then on every 4th row bind off 3 sts. 1 x, 2 sts. 1 x, decrease 1 st. 2 x; then decrease 1 st. on every 8th row 2 x. (40 sts.) Rows 299-361: Work even. Rows 362-422: **Neck and Shoulder Shaping.** For the neck shaping, bind off 4 sts.; then on every other row bind off 3 sts. 1 x, 2 sts. 1 x, decrease 1 st. 2 x; then decrease 1 st. every 4th row 2 x and every 8th row 3 x. **AT THE SAME TIME,** after Row 394, for the shoulder shaping, on every other row decrease 1 st. 6 x and bind off 2 sts. 9 x. Make another front section with reverse shapings.

SLEEVE: (Figure III). Make two. Cast on 65 sts. Rows 1-26: Work in Stockinette Stitch with Tension 6 (7). To make the hem put the cast on sts. back on the machine, put the gate cam release lever at the needle heels, and continue in holding position design with Tension 5 (6). Rows 27-74: Increase 1 st. on each side after Row 26 and again every 6th row 6 x. (79 sts.). Rows 75-162: **Underarm Shaping.** On each side of every 4th row bind off 4 sts. 1 x, 3 sts. 1 x, 2 sts. 3 x, decrease 1 st. 14 x, bind off 2 sts. 2 x, 3 sts. 1 x, and the remaining 11 sts.

FRONT EDGING: (Make 2). Cast on 147 sts. Work 26 rows Stockinette Stitch with Tension 6 (7) and bind off all sts.

NECK EDGING: Cast on 115 sts. Stockinette Stitch: 4 rows with Tension 7, 4 rows with Tension 6, 10 rows with Tension 5, 4 rows with Tension 6, and 4 rows with Tension 7. Bind off all sts.

FINISHING: Join the front and back sections at side and shoulder seams, easing in the fullness at bustline of front section. Sew sleeve edges together and sew sleeves to sweater. Fold front edgings around sweater fronts and attach. Fold neck edging around sweater neckline and attach. Sew a loop to the neck edging and sew on two buttons.

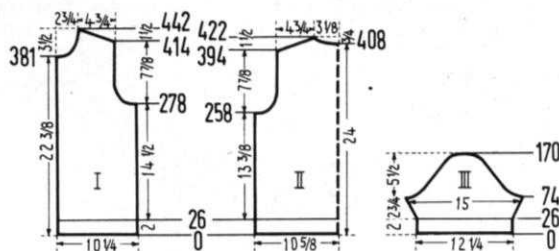

SIZE: 14/16. BACK: (Figure II). Cast on 118 sts. Rows 1-26: Work in Stockinette Stitch with Tension 6 (7). To make the hem put the cast on sts. back on the machine, place the gate cam release lever at the needle heels and continue in holding position design with Tension 5 (6). Rows 27-258: Work even. Rows 259-296: **Armhole Shaping.** Bind off 4 sts. beginning next 2 rows then on every 4th row, on each side, bind off 3 sts. 1 x, 2 sts. 2 x, decrease 1 st. 2 x; then decrease 1 st. every 8th row 2 x. (88 sts.). Rows 297-394: Work even. Rows 395-422: **Shoulder Shaping and Neck Shaping.** On each shoulder side of every other row decrease 1 st. 4 x and bind off 2 sts. 11 x. **AT THE SAME TIME,** for the neck shaping, after Row 408 bind off the 14 center sts., with a separate yarn, put the needles on the left into holding position and complete the right side first. When Cam box is on neck side (every other row) bind off 3 sts. 1 x, 2 sts. 3 x, and decrease 1 st. 2 x. Put all needles into working position, row counter back to 408 and complete the left side.

FRONT: (Figure I). Cast on 57 sts. Rows 1-26: Work in Stockinette Stitch with Tension 6 (7). To make the hem, put the cast on sts. back on the machine, place the gate cam release lever at the needle heels, and continue in holding position design with Tension 5 (6). Rows 27-278: Work even. Rows 279-316: **Armhole Shaping.** Bind off 4 sts.; then on every 4th row bind off 3 sts. 1 x, 2 sts. 2 x, decrease 1 st. 2 x; then on every 8th row decrease 1 st. 2 x. (42 sts.). Rows 317-381: Work even. Rows 382-442: **Neck and Shoulder Shaping.** For the neck shaping, bind off 4 sts.; then on every other row bind off 3 sts., 1 x, 2 sts. 1 x, decrease 1 st. 2 x; then decrease 1 st. every 4th row 2 x and every 8th row 3 x. **AT THE SAME TIME,** after Row 414, for the shoulder shaping, on every other row decrease 1 st. 4 x, and bind off 2 sts. 11 x. Make the second front section with reverse shapings.

SLEEVE: (Figure III). Make two. Cast on 69 sts. Rows 1-26: Work in Stockinette Stitch with Tension 6 (7). To make the hem, put the cast on sts. back on the machine. Place the gate cam release lever at the needle heels and continue in holding position design with Tension 5 (6). Rows 27-74: Increase 1 st. on each side after Row 26 and again every 6th row 6 x. (83 sts.). Rows 75-170: **Underarm Shaping.** On each side of every 4th row bind off 4 sts. 1 x, 3 sts. 1 x, 2 sts. 3 x, decrease 1 st. 16 x, bind off 2 sts. 2 x, 3 sts. 1 x, and the remaining 11 sts.

FRONT EDGING: Make 2. Cast on 154 sts. Work 26 rows Stockinette Stitch with Tension 6 (7), and bind off all sts.

NECK EDGING: Cast on 115 sts. Stockinette Stitch: 4 rows with Tension 7, 4 rows with Tension 6, 10 rows with Tension 5, 4 rows with Tension 6, and 4 rows with Tension 7. Bind off all sts.

FINISHING: Follow directions for Size 10/12.

CHANGE OF ADDRESS . . .

If you change your address be sure to notify us immediately. The Post Office will not forward your magazine from your old address and it will not be returned to us.

WOMAN'S PULLOVER, No. DP 7425



SIZES: 10/12 and 14/16. **MATERIAL:** Size 10/12 - 12¼ oz. white. Size 14/16 - 14 oz. white. **FOR EXAMPLE:** KNITTING Subita 2 x 4, Spinnerin, Nylaine Fingering, Diamond Pastel D'Aoust. Both sizes 2 oz. KNITTING Subita 2 x 3. **TENSION:** KNITTING 7 or 8. **GAUGE:** Pattern Stitch 19 sts. 2", 21 rows 2"; K. 1, P. 1 Ribbing 19 sts. 2", 24 rows 2". The non-working-position sts. are counted in the gauge and in the directions. **PATTERN:** Ribbing of 5 knit sts., 2 purl sts. Edgings: K. 1, P. 1, Ribbing.

SIZE: 10/12. BACK: (Figure II). Cast on 179 sts. with 2 x 4 yarn on the left side at the 9th needle begin with 2 needles on the main machine. Rows 1-14: K. 1, P. 1 Ribbing. Now put the 1st, 4th, 5th, 8th, 9th, etc. sts. from the Ribber onto the empty needles of the main machine and put the

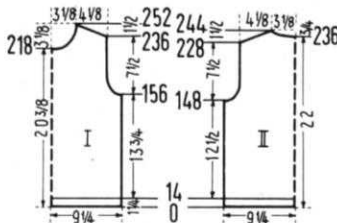

6th, 14th, 22nd, 30th, etc. sts. onto the neighboring needle, put the empty needles out of operation and continue in stripe pattern. Rows 15-148: Work even. Rows 149-168: **Armhole Shaping.** Bind off 6 sts. beginning next 2 rows; then on every other row, on each side bind off 4 sts. 1 x, 3 sts. 1 x, 2 sts. 1 x, decrease 1-st. 2 x; and then decrease 1 st. on every 4th row 2 x. (141 sts.). Rows 169-228: Work even. Rows 229-244: **Shoulder and Neck Shaping.** On each shoulder side of every other row bind off 4 sts. 5 x and 5 sts. 4 x. **AT THE SAME TIME,** for the neck shaping, after Row 236 bind off the 23 center sts., with a separate yarn, put needles on the left into holding position and complete the right side first. Be sure to transfer all ribber sts. to main machine before binding off or putting needles in holding position. When Cam box is on neck side (every other row) bind off 8 sts. 1 x, 6 sts. 1 x, and 5 sts. 1 x. Replace the proper rib sts. to ribber, all needles in work, row counter back to 236 and complete the left side.

FRONT: (Figure I). The front is worked the same as the back to Row 152. Rows 153-160: Work even. Rows 161-184: **Armhole Shaping.** Bind off 6 sts. beginning next 2 rows, then on every other row, on each side, bind off 4 sts. 1 x, 3 sts. 1 x, 2 sts. 1 x, decrease 1 st. 2 x, and then decrease 1 st. on every 4th row 2 x. (141 sts.). Rows 177-218: Work even. Rows 219-252: **Neck and Shoulder Shaping.** For the neck shaping, bind off the 27 center sts. with a separate yarn. (Be sure to transfer the rib sts. as you did for back). Put needles on the left into holding position and complete the right side first. When Cam box is on neck side (on every other row), bind off 4 sts. 1 x, 3 sts. 2 x, 2 sts. 1 x, decrease 1 st. 2 x; and then decrease 1 st. every 4th row 2 x and on the 6th row 1 x. **AT THE SAME TIME,** after row 236, for the shoulder shaping, on every other row bind off 4 sts. 5 x and 5 sts. 4 x. Transfer the rib stitches to ribber as you did before, all needles in work, row counter back to 252 and complete the left side.

NECK EDGING: Cast on 151 sts. with 2 x 3 yarn. Work K. 1, P. 1. Ribbing: 10 rows, with Tension 6, 14 rows with Tension 5, and 8 rows with Tension 6; then work 4 rows Stockinette with Tension 4. Bind off all sts.

ARMHOLE EDGINGS: (Make 2). Cast on 151 sts. with 2 x 3 yarn. Work K. 1, P. 1. Ribbing: 6 rows with Tension 6, 10 rows with Tension 5, and 4 rows with Tension 6; then work 4 rows Stockinette Stitch with Tension 4. Bind off all sts.

FINISHING: Join front and back sections at side seams in slip stitch, overlapping 1½ sts. from each section and easing in the fullness at bustline of front section. Sew shoulder seams. Sew ends of neck edging, so that edging is circular. Fold the neck edging around sweater neckline, so that the knit sts. are on the outside, and attach. Sew the ends of each section of armhole edging so that edging is circular. Fold the edgings around the armhole openings, knit sts. out, and attach.

SIZE: 14/16. BACK: (Figure II). Cast on 195 sts. with 2 x 4 yarn. On the left side at the 1st needle begin with 2 needles on the main machine. Rows 1-14: K. 1, P. 1 Ribbing. Now put the 1st, 4th, 5th, 8th, 9th, etc. sts. from the Ribber onto the empty needles of the main machine, and put the 6th, 14th, 22nd, 30th, etc. sts. onto the neighboring needle, put the empty needles out of operation and continue in stripe pattern. Rows 15-152: Work even. Rows 153-176: **Armhole Shaping.** Bind off 6 sts. beginning next 2 rows, then on every other row, on each side, bind off 4 sts. 1 x, 3 sts. 1 x, 2 sts. 3 x, decrease 1 st. 2 x, then decrease 1 st. on every 4th row 2 x. (149 sts.). Rows 177-236: Work even. Rows 237-252: **Shoulder and Neck Shaping.** On each shoulder side of every other row bind off 4 sts. 3 x, 5 sts. 4 x, and 6 sts. 2 x. **AT THE SAME TIME,** for the neck shaping, after Row 244, bind off the 23 center sts., with a separate yarn, put needles on the left into holding position and complete the right side first. Be sure to transfer the ribber sts. to Main Machine before binding off or putting needles in Holding position. When Cam box is on neck side (every other row) bind off 8 sts. 1 x, 6 sts. 1 x, and 5 sts. 1 x. Replace the proper rib sts. to ribber, all needles in work, row counter back to 244 and complete the left side.

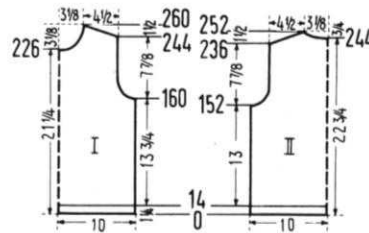

FRONT: (Figure I). The front is worked the same as the back to Row 152. Rows 153-160: Work even. Rows 161-184: **Armhole Shaping.** Bind off 6 sts. beginning next 2 rows, then on every other row, on each side, bind off 4 sts. 1 x, 3 sts. 1 x, 2 sts. 1 x, decrease 1 st. 2 x; then decrease 1 st. on every 4th row 2 x. (149 sts.). Rows 185-226: Work even. Rows 227-260: **Neck and Shoulder Shaping.** For the neck shaping bind off the 27 center sts., with a separate yarn. (Be sure to transfer the rib sts. as you did for back) put needles on the left into holding position and complete the right side first. When Cam box is on neck side (every other row) bind off 4 sts. 1 x, 3 sts. 2 x, 2 sts. 1 x, decrease 1 st. 2 x; then decrease 1 st. every 4th row 2 x and on the 6th row 1 x. **AT THE SAME TIME,** after Row 244, for the shoulder shaping, on shoulder side of every other row bind off 4 sts. 3 x, 5 sts. 4 x, and 6 sts. 2 x. Transfer the rib sts. to ribber as you did before, all needles in work, row counter back to 226 and complete the left side.

NECK EDGING: Cast on 151 sts. with 3 ply yarn. Work K. 1, P. 1 Ribbing: 10 rows with Tension 6, 14 rows with Tension 5 and 8 rows with Tension 6; then work 4 rows Stockinette with Tension 4. Bind off all sts.

ARMHOLE EDGINGS: (Make 2). Cast on 161 sts. with 3 ply yarn. Work K. 1, P. 1 Ribbing: 6 rows with Tension 6, 10 rows with Tension 5, 4 rows with Tension 6; then work 4 rows Stockinette Stitch with Tension 4. Bind off all sts.

FINISHING: Follow directions for Size 10/12.

**BE SURE TO USE YOUR ZIP CODE
IN ALL CORRESPONDENCE.**

continue in holding position design with Tension 2 (3). Rows 13-448: Increase 1 st. on each side after Row 26 and again every 14th row 28 x. (143 sts.). Rows 449-480: **Underarm Shaping.** On every 4th row on the back side of the sleeve bind off 4 sts. 1 x, 3 sts. 3 x, 2 sts. 3 x, decrease 1 st. 1 x; and on the front side of the sleeve bind off 6 sts. 1 x, 5 sts. 1 x, 4 sts. 1 x, 3 sts. 2 x, and 2 sts. 3 x. Rows 481-596: Decrease 1 st. on each side of every 4th row 29 x. Rows 597-616: On each side of every 4th row bind off 2 sts. 2 x, 3 sts. 2 x, 4 sts. 1 x, and the remaining 10 sts. Make another sleeve with reverse shapings.

FINISHING: Follow directions for Size 14/16; however, make darts at the bustline of the front section as illustrated in the diagram.

WOMAN'S BLOUSE, No. DP 7426



SIZES: 14/16 and 18/20. **MATERIAL:** Size 14/16 - 9 oz. white and 7 oz. blue. Size 18/20 - 11 oz. white and 7 oz. blue. **FOR EXAMPLE:** KNITTING, Fine Dralon, Diamond Laine Ecosaise Fine 2 ply yarn. **TENSION:** KNITTING Pattern Stitch 4 or 5; Stockinette Stitch 2 or 3. **GAUGE:** Pattern Stitch 16 sts. 2", 64 rows 2"; Stockinette Stitch 16 sts. 2", 30 rows 2". **PATTERN:** Holding Position Design on knit side according to chart. Dial-A-Stitch machines, at the beginning of the pattern stitch put the

needles into holding position with Wheel VI, then use the Needle Shifter. Edging: Stockinette.

11-12	WHITE
9-10	BLUE
7-8	WHITE
5-6	BLUE
3-4	WHITE
1-2	BLUE

SIZE: 14/16. **BACK:** (Figure II). Cast on 161 sts. with white. Rows 1-24: Work in Stockinette Stitch with Tension 2 (3). Continue in Holding Position Design with Tension 4 (5). Rows 25-472: Work even. Rows 473-534: **Armhole Shaping.** Bind off 3 sts. beginning next 2 rows, then on each side of every 4th row bind off 3 sts. 1 x, 2 sts. 2 x, decrease 1 st. 3 x; then decrease 1 st. every 6th row 2 x and every 8th row 3 x. (125 sts.). Rows 535-714: Work even. Rows 715-766: **Shoulder and Neck Shaping.** On each shoulder side of every other row decrease 1 st. 17 x and bind off 2 sts. 10 x. **AT THE SAME TIME,** for the neck shaping, after Row 740 bind off the 23 center sts., with a separate yarn, put needles on the left into holding position and complete the right side. When Cam box is on neck side on every 4th row bind off 4 sts. 1 x, 3 sts. 2 x, and 2 sts. 2 x. Bring all needles into work, row Counter back to 740 and complete the left side.

FRONT: (Figure I). Cast on 87 sts. with white. Rows 1-24: Work in Stockinette Stitch with Tension 2 (3). Continue in Holding Position Design with Tension 4 (5). Rows 25-190: Work even. Now make the pocket. To do this, on the left side put 29 needles in holding position, and on the right side put 16 needles in holding position. Work 40 rows Stockin-

ette over the needles in working position with white yarn and Tension 2 (3), and bind off these sts. For the pocket lining, over these same needles cast on 42 sts. and work 116 rows in Pattern Stitch. Now turn the row counter back to 190 and continue on over all the needles. Rows 191-498: Work even. Rows 499-562: **Armhole Shaping.** Bind off 6 sts.; then on every 4th row bind off 4 sts. 1 x, 3 sts. 1 x, 2 sts. 2 x, decrease 1 st. 3 x; then decrease 1 st. every 6th row 3 x and every 8th row 2 x. (62 sts.). Rows 563-689: Work even. Rows 690-792: **Neck and Shoulder Shaping.** For the neck shaping, bind off 9 sts.; then on every 4th row bind off 3 sts. 1 x, 2 sts. 2 x, decrease 1 st. 2 x; then decrease 1 st. every 6th row 2 x, every 8th row 2 x, and every 10th row 3 x. **AT THE SAME TIME,** after Row 740, for the shoulder shaping, on every other row decrease 1 st. 17 x and bind off 2 sts. 10 x. Make another front section with reverse shapings.

SLEEVE: (Figure III). Cast on 97 sts. with white. Rows 1-24: Work in Stockinette Stitch with Tension 2 (3). To make the hem, put the cast on sts. back on the machine and continue in Holding Position Design with Tension 4 (5). Rows 25-126: Increase 1 st. on each side after Row 32 and again every 8th rows 10 x. (119 sts.). Rows 127-168: **Underarm Shaping.** On every 4th row on the back side of the sleeve bind off 4 sts. 1 x, 3 sts. 2 x, 2 sts. 3 x, decrease 1 st. 4 x; and on the front side of the sleeve bind off 6 sts. 1 x, 4 sts. 1 x, 3 sts. 2 x, 2 sts. 4 x, and decrease 1 st. 2 x. Rows 169-268: Decrease 1 st. on each side after Row 168 and again every 6th row 16 x. Rows 269-292: On each side of every 4th row decrease 1 st. 2 x, bind off 2 sts. 1 x, 3 sts. 2 x, 4 sts. 1 x, and the remaining 11 sts. Make another sleeve with reverse shapings.

FRONT EDGINGS: (Make 2). Cast on 164 sts. with white. Work 24 rows Stockinette Stitch with Tension 2 (3) and bind off all sts.

NECK EDGING: Cast on 153 sts. with white. Work Stockinette Stitch: 8 rows with Tension 2, 12 rows with Tension 1 and 8 rows with Tension 2. Bind off all sts.

FINISHING: Join front and back sections at side and shoulder seams, easing in the fullness at bustline of front sections. Make a hem 1 1/2" wide around bottom of blouse. Sew pocket lining to wrong side of blouse. Fold the pocket edging in half toward the inside so that only the knit stitches are visible; then fold the edging to the outside and fasten the sides of the edging to the jacket. Fold the front edgings around the jacket openings and attach: in so doing, make six buttonholes on the right front section. To make the first buttonhole count up 7 sts. from the bottom edge and leave 5 sts. open. The remaining buttonholes will be spaced 25 sts. apart, and each one will be 5 sts. long. Fold the neck edging around the jacket neckline and attach. Finish buttonholes and sew on buttons.

SIZE: 18/20. **BACK:** (Figure II). Cast on 179 sts. with white. Rows 1-24: Work in Stockinette Stitch with Tension 2 (3). Continue in Holding Position Design with Tension 4 (5). Rows 25-472: Work even. Rows 473-536: **Armhole Shaping.** Bind off 4 sts. beginning next 2 rows; then on every 4th row, on each side, bind off 3 sts. 2 x, 2 sts. 2 x, decrease 1 st. 3 x; then decrease 1 st. every 6th row 3 x and every 8th row 2 x. (135 sts.). Rows 537-740: Work even. Rows 741-792: **Shoulder and Neck Shaping.** On each shoulder side of every other row decrease 1 st. 12 x and bind off 2 sts. 15 x. **AT THE SAME TIME,** for the neck shaping, after Row 766, bind off the 23 center sts. with a separate yarn, put needles on the

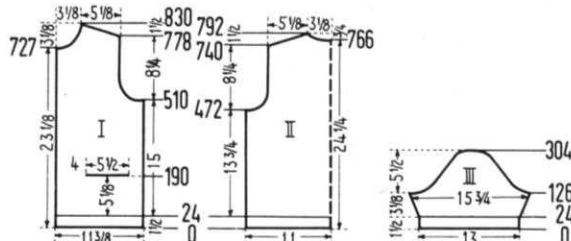
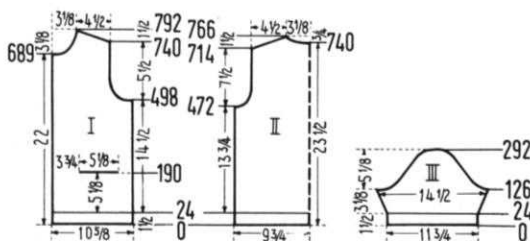

left into holding position and complete the right side first. When Cam box is on neck side on every 4th row bind off 4 sts. 1 x, 3 sts. 2 x, and 2 sts. 2 x. Bring all needles into work, row Counter back to 766 and complete the left side.

FRONT: (Figure I). Cast on 93 sts. with white. Rows 1-24: Work in Stockinette Stitch with Tension 2 (3). Continue in Holding Position Design with Tension 4 (5). Rows 25-190: Work even. Now make the pocket. To do this, put 32 needles on the left side and 16 needles on the right side into holding position. Over the needles remaining in working position work 40 rows Stockinette Stitch with white, in Tension 2 (3) and bind off all sts. To make the pocket lining, over these same needles cast on 45 sts. and work 116 rows in pattern stitch. Now turn the Row Counter back to 190 and continue working over all the needles. Rows 191-510: Work even. Rows 511-574: **Armhole Shaping.** Bind off 6 sts. then on every 4th row bind off 4 sts. 1 x, 3 sts. 1 x, 2 sts. 3 x, decrease 1 st. 2 x; then decrease 1 st. every 6th row 3 x and every 8th row 2 x. (68 sts.). Rows 575-727: Work even. Rows 728-830: **Neck and Shoulder Shaping.** For the neck shaping, bind off 9 sts.; then on every 4th row bind off 3 sts. 1 x, 2 sts. 2 x, decrease 1 st. 2 x; then decrease 1 st. every 6th row 2 x, every 8th row 2 x, and every 10th row 3 x. **AT THE SAME TIME,** after Row 778, for the shoulder shaping, on every

other row decrease 1 st. 12 x and bind off 2 sts. 15 x. Make another front section with reverse shapings.

SLEEVE: (Figure III). Cast on 106 sts. with white. Rows 1-24: Work in Stockinette Stitch with Tension 2 (3). To make the hem, put the cast on sts. back on the machine and continue in Holding Position Design with Tension 4 (5). Rows 25-126: Increase 1 st. on each side after Row 32 and again every 8th row 10 x. (128 sts.). Rows 127-168: **Underarm Shaping.** On every 4th row on the back side of the sleeve bind off 4 sts. 1 x, 3 sts. 2 x, 2 sts. 5 x, decrease 1 st. 2 x; and on the front side of the sleeve bind off 6 sts. 1 x, 4 sts. 1 x, 3 sts. 3 x, 2 sts. 3 x, and decrease 1 st. 2 x. Rows 169-280: Decrease 1 st. on each side after Row 168 and again every 6th row 18 x. Rows 281-304: On each side of every 4th row decrease 1 st. 1 x, bind off 2 sts. 2 x, 3 sts. 2 x, 4 sts. 1 x, and the remaining 11 sts. Make another sleeve with reverse shapings.

FRONT EDGINGS: (Make 2). Cast on 170 sts. with white. Work 24 rows Stockinette Stitch with Tension 2 (3) and bind off all sts.

NECK EDGING: Cast on 153 sts. with white. Work Stockinette Stitch: 8 rows with Tension 2, 12 rows with Tension 1, and 8 rows with Tension 2. Bind off all sts.

FINISHING: Follow directions for size 14/16.

BEGINNERS PATTERNS . . .

MAN'S SHIRT, No. HP 3458

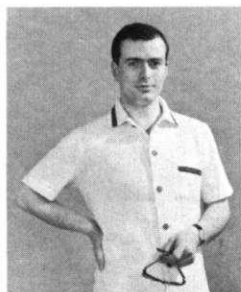

SIZE: 42/44. **MATERIAL:** 22 oz. White and small amounts of Red and Blue. **FOR EXAMPLE:** KNITKING Subita 2 x 3 or Mutella. Brunswick Fairhaven, Bearbrand Deluxe Sock and Sport. **TENSION:** KNITKING 5 or 6. **GAUGE:** 17 sts. 2", 22 Rows 2". **PATTERN:** Stockinette. Blocked Measurements: Chest 43" to 44". Sleeve Width at Underarm 15 1/2" Length from back of neck to bottom edge 26".

BACK: (Figure II). Cast on 177 sts. Rows 1-34: Knit even.

Make a hem by picking up each cast on stitch and hang the stitches back on the machine being sure to place them behind the latches.

Knit even till counter reads 206.

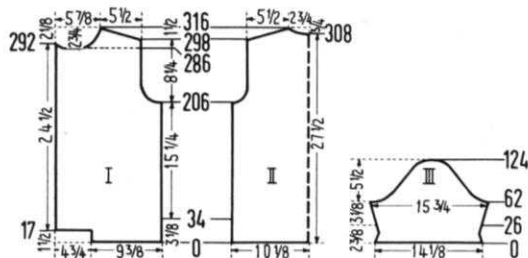

ARMHOLE SHAPING: Bind off 4 sts. beginning next 2 rows. Bind off 3 sts. when counter reads: 208, 209.

Bind off 2 sts. when counter reads: 210, 211, 212, 213, 214, 215. Decrease 1 st. ON EACH SIDE when counter reads: 216, 218, 222, 226.

Stitches in Work - 143.

Knit even till counter reads 298.

SHAPE SHOULDER AND NECK: Bind off 4 sts. beginning

next 4 rows. Bind off 5 sts. beginning next 6 rows.

When counter reads 308 bind off center 21 sts. for neck with a separate yarn. Put all needles on the left side into holding position and continue working on right side only. Continue shaping shoulder and NECK at the same time When Cam Box is on

	NECK SIDE	SHOULDER SIDE
(every other row) Bind off	6 sts. 1 x	5 sts. 5 x
	4 sts. 1 x	
	3 sts. 1 x	

Bring all needles into working position, put row counter back to 308 and complete the left side.

FRONT: (Figure I). Cast on 82 sts.

Knit till counter reads 17. Cast on 41 sts. on the LEFT SIDE. Knit till counter reads 34.

Make hem by hanging each of the 82 cast on sts. back on the machine. Be sure to put the sts. behind the latches. Knit even till counter reads 206.

ARMHOLE SHAPING: Bind off 7 sts. then on every other row on Arm side Bind off 5 sts.

	1 x
	3 sts. 2 x
	2 sts. 1 x
	decrease 1 st. 2 x

On every 4th row decrease 1 st. 2 x (99 sts. in work).

Knit even till counter reads 286.

SHAPE NECK: Counting from the RIGHT EDGE, bind off the 69th to 89th sts. for NECK. Put the needles on the RIGHT side into holding position and complete the LEFT side first. On every other row on NECK SIDE bind off 4 sts. 1 x and 3 sts. 2 x.

Put Cam box on the Right side, all needles in work. Put row counter back to 286. On every other row, on NECK SIDE bind off 4 sts. 1 x, 3 sts. 2 x, 2 sts. 3 x.

Counter will read 298. Continue to decrease on NECK SIDE and at same time SHAPE SHOULDER as listed in column.

	NECK SIDE	SHOULDER SIDE
On every other row on		(every other row)
Decrease	1 st. 2 x	bind off 4 sts. 2 x
On every 4th row		5 sts. 8 x
(neck side only)	1 st. 2 x	

Make second Front section with REVERSE SHAPING, making buttonholes over the 9th to 14 and 28th to 33rd needles when counter reads: 28, 78 128, 178, 228.

SLEEVES: (Figure III). Cast on 122 sts.

Decrease 1 st. ON EACH SIDE when counter reads 2, 6, 10. Increase 1 st. ON EACH SIDE when counter reads 16, 20, 24. When counter reads 26, hang the cast on sts. back on the machine to form a hem. Be sure to put the stitches behind the latches.

Knit 2 rows.

Increase 1 st. ON EACH SIDE when counter reads 28, 32, 36, 40, 44, 48, 52. Knit even till counter reads 62.

UNDERARM SHAPING: On every other row bind off as listed for Back and Front Side of sleeve.

RIGHT (Back side)

5 sts. 1 x
3 sts. 3 x
2 sts. 3 x

LEFT (Front side)

7 sts. 1 x
5 sts. 1 x
3 sts. 3 x
2 sts. 2 x

When counter reads 66 *On each side of every other row decrease 1 st. 2 x and bind off 2 sts. 1 x* Repeat from * to * 6 x.

When counter reads 118 On every other row ON EACH SIDE Bind off 3 sts. 1 x, 4 sts. 1 x, 5 sts. 1 x.

Bind off remaining 12 sts.

Make another sleeve with reverse shaping, changing the RIGHT side to FRONT of sleeve and the LEFT side to BACK of sleeve.

COLLAR: (See "Notes to Knit By" on inside back cover — short rows.)

Cast on 136 sts.

Rows 1-8: On the LEFT SIDE, put 48 needles in holding position and knit 1 row. On the RIGHT SIDE put 48 needles in holding position and knit 1 row.

ON EACH SIDE return 16 needles to working position 3 x.

Knit even till counter reads 50.

Now knit 2 rows Blue, 4 rows Red, 2 rows Blue.

Change to main yarn and continue knitting till counter reads 80.

On EACH SIDE put 9 needles in holding position 5 x.

Counter reads 90. On the LEFT SIDE bring all needles into working position and knit 1 row.

On the RIGHT SIDE bring all needles into working position and knit 1 row.

Bind off all stitches using the crochet method.

POCKET: Cast on 41 sts.

Knit even till counter reads 38.

Make stripes as follows: Knit 2 rows Blue, 4 rows Red, 2 rows Blue. Change to main yarn and knit till counter reads 66. Bind off all stitches using the crochet method.

FINISHING: Weave the front and back sections at sides. Join shoulder seams from wrong side using slip stitch crochet or back stitch.

Weave sleeve edges together and with right sides together pin sleeve into armhole. Slip stitch crochet around the armhole being careful not to pull too tightly. Check from time to time to see that you have a nice neat right side.

Make a hem 2 1/4" wide at front edge. Fold Collar section in half and sew side edges together. Place open end of collar around neck opening and pin in place, then carefully stitch in place. Make a 1 1/4" hem at top of pocket and sew to shirt as illustrated.

Finish Buttonholes and sew on buttons.

PLEASE NOTE THAT WE DO NOT SEND TOOLS AND YARNS OUT ON A C.O.D. BASIS. YOU MUST SEND PAYMENT INCLUDING MAILING COSTS WITH EACH ORDER.

MAN'S SHIRT, No. HP 3457

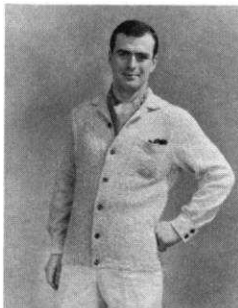

SIZE: 40/42. **MATERIAL:** 9 (50 gram balls). **FOR EXAMPLE:** KNITTING Natural Linen Cotton. **TENSION:** KNITTING 5 or 6. **GAUGE:** 17 sts. 2", 21 rows 2". **PATTERN:** Stockinette. Blocked Measurements: Chest 42" to 44". Length from back of neck to bottom 26". Length of Sleeve from top of shoulder to wrist 24".

BACK: (Figure II). Cast on 178 sts.. Knit till counter reads 34. To make the hem, hang each cast on stitch back on machine and put behind the latches. Knit till counter reads 198.

ARMHOLE SHAPING: Bind off 4 sts. beginning next 2 rows, 3 sts. beginning next 2 rows, 2 sts. beginning next 6 rows. Decrease 1 st. ON EACH SIDE when counter reads 210, 212, 216, 220. Needles in work — 144.

Knit till counter reads 290.

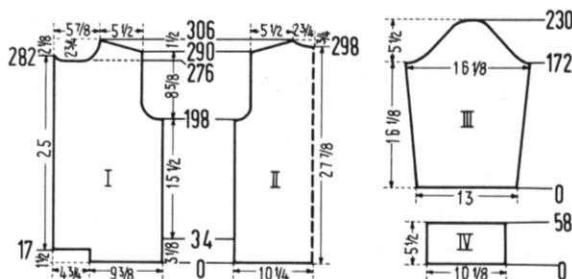

SHOULDER AND NECK SHAPING: Bind off 5 stitches beginning next 7 rows. When counter reads 298 bind off 5 sts. and with a separate yarn, bind off the center 18 sts. for neck. Put the needles on the LEFT into holding position and continue on right side only.

When Cam box is on NECK and SHOULDER side bind off as listed in proper column (every other row).

NECK SIDE

6 sts. 1 x
5 sts. 1 x
4 sts. 1 x

SHOULDER SIDE

5 sts. 2 x
6 sts. 3 x

Bring all needles into working position. Put row counter back to 298 and complete the left side.

FRONT: (Figure I). Cast on 82 sts. Knit till counter reads 17, then on LEFT SIDE cast on 41 sts.

When counter reads 34, make a hem by hanging the 82 cast on stitches back on the machine and put behind the latches. Knit till counter reads 198.

ARMHOLE SHAPING: Bind off 6 sts., then on EVERY OTHER ROW on ARM SIDE bind off 5 sts. 1 x, 4 sts. 1 x, 3 sts. 1 x, 2 sts. 1 x, then decrease 1 st. 2 x. (99 sts.).

Knit even till counter reads 276.

NECK AND SHOULDER SHAPING: Counting from the RIGHT edge, bind off the 69 to 89th stitches with a separate yarn, put the needles on the RIGHT side into holding position and complete the LEFT SIDE FIRST. When Cam box is on NECK SIDE (every other row) Bind off 4 sts. 1 x
3 sts. 2 x

Put the Cam box on the right side, all needles in work, row counter back to 276. When Cam box is on neck side (every other row) Bind off or decrease as listed in column and shape shoulder at the same time as listed.

NECK SHAPING

Bind off 4 sts. 1 x
3 sts. 2 x
2 sts. 3 x
decrease 1 st. 4 x

SHOULDER SHAPING

When counter reads 290
bind off 5 sts. 6 x
6 sts. 3 x

Make a second front section with reverse shapings and make buttonholes over the 10th-14th and 28th-32nd needles — when counter reads 26, 68, 110, 152, 194, and 236.

SLEEVE: (Figure III). Cast on 112 sts.

Increase 1 st. ON EACH SIDE when counter reads 12, 24, 36, 48, 60, 72, 84, 96, 108, 120, 130, 140, 150, 160. (140 sts.)
Knit till counter reads 172.

UNDERARM SHAPING: On every other row, bind off as listed for Front and Back side of Sleeve.

RIGHT (Back Side)	LEFT (Front Side)
4 sts. 2 x	6 sts. 1 x
3 sts. 1 x	5 sts. 1 x
2 sts. 4 x	4 sts. 1 x
	3 sts. 2 x
	2 sts. 2 x

When counter reads 186 *On each side of every other row decrease 1 st. 1 x and bind off 2 sts. 1 x*. Repeat from * to * 8 x.

When counter reads 222, on each side of every other row
Bind off 2 sts. 1 x
3 sts. 1 x
4 sts. 1 x
5 sts. 1 x

Bind off remaining 14 sts.

Make another sleeve with reverse shaping, changing the RIGHT side to FRONT of sleeve and the LEFT side to BACK of sleeve.

CUFFS: (Figure IV). Cast on 88 sts.

Knit in stockinette. Counting from the RIGHT edge, make buttonholes over the 6th to 10th needles when counter reads 8, 20, 38, 50.

Knit to row 58. Bind off all stitches.

Make a second cuff and reverse buttonholes by counting from the LEFT edge.

COLLAR: (See "Notes to Knit By" on inside back cover — short rows).

Cast on 133 sts.

Rows 1-20: On the LEFT SIDE, put 48 needles in holding position and knit 1 row. On the RIGHT SIDE, put 48 needles in holding position and knit 1 row. Working from side to side and always bringing group of needles opposite Cam box into working position — ON EACH SIDE, bring 9 needles into working position 2 x, 6 needles 3 x, 3 needles 4 x. Work even till counter reads 72.

ON EACH SIDE put 4 needles in holding position 3 x
7 needles in holding position 2 x
9 needles in holding position 2 x

On the LEFT SIDE bring all needles into working position and knit 1 row. On the RIGHT SIDE bring all needles into working position and knit 1 row. Bind off all stitches using crochet method.

POCKET: Cast on 44 sts.

Knit till counter reads 24

Make hem by hanging each cast on stitch back on machine and put behind the latches.

Knit till counter reads 66

Bind off all stitches using crochet method.

FINISHING: Weave the front and back sections at side seams. Slip stitch crochet or back stitch shoulder seams. Weave sleeve edges together and pin sleeves to armhole right sides together. Slip st. crochet or back stitch the sleeves into shirt. Make a 2 1/4" hem at front edges of shirt. Fold collar section in half lengthwise and sew ends together. Place open edge of collar around shirt neckline and attach, leaving 1" at both front edges unattached. Make small pleats around bottom of sleeve. Fold cuff sections in half and sew ends together. Place open end of cuff around sleeve bottom and attach, leaving 1/2" on each side of cuff and 1 1/4" of sleeve bottom unattached. Sew pocket on shirt as illustrated. Finish buttonholes and sew on buttons.

MAN'S CARDIGAN, No. HP 3443



SIZES: 40/42 and 44/46. **MATERIAL:** Size 40/42 - 30 ozs. grey. Size 44/46 - 34 oz. grey. **FOR EXAMPLE:** KNITTING Frigate. Spinnerin Knitting Worsted, or Orlon Sayelle. **TENSION:** KNITTING 10. **GAUGE:** 19 sts. 4", 26 rows 4". The non-working-position sts. are not counted in the gauge or in the directions. **PATTERN:** Stockinette Stitch over every other needle. The back is worked in two sections. **SIZE: 40/42. BACK:** (Figure II). Cast on 53 sts. over every other needle. Rows 1-10: Work even with Tension

8. Continue with Tension 10. Rows 11-124: Work even. Rows 125-138: **Armhole Shaping.** Bind off 3 sts.; then, on every other row bind off 2 sts. 2 x, decrease 1 st. 2 x; then decrease 1 st. on the 4th row 1 x. (43 sts.) Rows 139-182: Work even. Rows 183-192: **Shoulder and neck shaping.** On the shoulder edge, on every other row bind off 4 sts. 3 x and 5 sts. 3 x. **AT THE SAME TIME,** for the neck shaping, after Row 187 bind off 7 sts.; then on every other row bind off 5 sts. 1 x. and 4 sts. 1 x. Make the second back section with reverse shapings.

FRONT: (Figure I). Cast on 52 sts. over every other needle. Rows 1-10: Work even with Tension 8. Continue with Tension 10. Rows 11-124: On the left side, cast on 15 sts. after Row 11. Rows 125-138: **Armhole Shaping.** Bind off 5 sts.; then on every other row bind off 3 sts. 1 x, 2 sts. 1 x, decrease 1 st. 2 x; then decrease 1 st. on the 4th row 1 x. (54 sts.) Rows 139-167: Work even. Rows 168-192: **Neck and Shoulder Shaping.** For the neck shaping, bind off 16 sts.; then on every other row bind off 3 sts. 1 x, 2 sts. 2 x, decrease 1 st. 2 x, then decrease 1 st. every 4th row 2 x. **AT THE SAME TIME,** after Row 182, for the shoulder shaping, on every other row bind off 4 sts. 3 x and 5 sts. 3 x. Make the second section with

reverse shapings, making **BUTTONHOLES** after Rows 15, 46, 77, 108, and 139 over the 2nd-5th and 11th-14th needles.

SLEEVE: (Figure III). Cast on 50 sts. over every other needle. Rows 1-20: Work even with Tension 8. Continue with Tension 10. Rows 21-130: Increase 1 st. on each side after Row 26 and again every 6th row 8 x and every 8th row 6 x. (80 sts.) Rows 131-140: **Underarm Shaping.** On every other row, on the back side of the sleeve bind off 3 sts. 2 x, 2 sts. 2 x, decrease 1 st. 1 x; and on the front side bind off 4 sts. 1 x, 3 sts. 2 x, and 2 sts. 2 x. Rows 141-160: *On each side of every other row decrease 1 st. 1 x and bind off 2 sts. 1 x*. Repeat from * to * 4 x. Rows 161-166: **On each side** of every other row bind off 2 sts. 1 x, 3 sts. 1 x, 4 sts. 1 x, and the remaining 7 sts. Make another sleeve with reverse shapings.

NECK EDGING: Cast on 88 sts. over every other needle. Work 14 rows even, making **BUTTONHOLES** after Rows 3 and 11 over the 4th - 7th needles. Bind off all sts. If you have a machine with 164 needles make collar in 2 sections by casting on 44 sts. for each section.

POCKETS: (Make 2). Cast on 27 sts. Work 32 rows with Tension 10 and 8 rows with Tension 8. Bind off all sts.

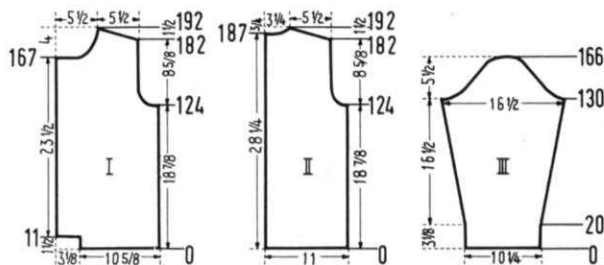

FINISHING: Weave the back sections together, overlapping 1 st. from each section. Weave the front and back sections at side and shoulder seams. Weave sleeve edges and sew sleeves to cardigan. Make a hem 10 rows wide at the bottom of the cardigan and the bottom of the sleeves. Make a hem $1\frac{1}{2}$ " wide at the front edges. Fold neck edging around neckline and attach. Make a hem 8 rows wide at the pocket tops, and then sew the pockets to the cardigan. Finish buttonholes and sew on buttons. With dark green yarn, make the ornamental stitching on the neck and pocket edges as illustrated. To do this, sew over 1 stitch and under 1 stitch.

SIZE: 44/46. **BACK:** (Figure II). Cast on 57 sts. over every other needle. Rows 1-10: Work even with Tension 8. Continue with Tension 10. Rows 11-128: Work even. Rows 129-144: **Armhole Shaping.** Bind off 3 sts.; then on every other row bind off 3 sts. 1 x, 2 sts. 1 x, decrease 1 st. 3 x; then decrease 1 st. on the 4th row 1 x. (45 sts.). Rows 145-188: Work even. Rows 189-198: **Shoulder and Neck Shaping.** For the **shoulder shaping**, on every other row bind off 4 sts. 2 x and 5 sts. 4 x. **AT THE SAME TIME**, for the **neck shaping**, after Row 193 bind off 8 sts.; then on every other row bind off 5 sts. 1 x and 4 sts. 1 x. Make the second back section with reverse shapings.

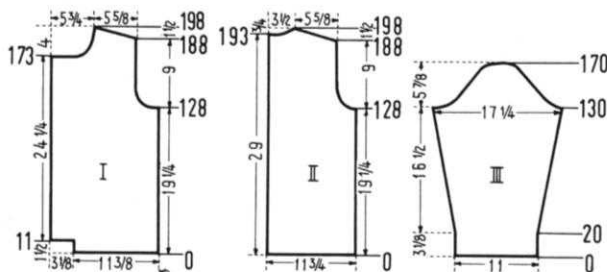

FRONT: (Figure I). Cast on 56 sts. over every other needle. Rows 1-10: Work even with Tension 8. Continue with Tension 10. Rows 11-128: On the **left side** cast on 15 sts. after Row 11. Rows 129-144: **Armhole Shaping.** Bind off 5 sts.; then on every other row bind off 3 sts. 1 x, 2 sts. 2 x, decrease 1 st. 2 x; then decrease 1 st. on the 4th row 1 x. (56 sts.). Rows 145-173: Work even. Rows 174-198: **Neck and Shoulder Shaping.** For the **neck shaping** bind off 17 sts.; then on every other row bind off 3 sts. 1 x, 2 sts. 2 x, decrease 1 st. 2 x and then on every 4th row decrease 1 st. 2 x. **AT THE SAME TIME**, after Row 188, for the **shoulder shaping**, on every other row bind off 4 sts. 2 x and 5 sts. 4 x. Make the second section with reverse shapings, making **BUTTONHOLES** after Rows 16, 48, 80, 112, and 144, over the 2nd-5th and 11th-14th needles.

SLEEVE: (Figure III). Cast on 54 sts. over every other needle. Rows 1-20: Work even with Tension 8. Continue with Tension 10. Rows 21-130: Increase 1 st. on each side after Row 26 and again every 6th row 8 x and every 8th row 6 x. (84 sts.). Rows 131-142: **Underarm Shaping.** On every other row on the **back side** of the sleeve bind off 3 sts. 2 x, 2 sts. 2 x, decrease 1 st. 2 x; and on the **front side** of the sleeve bind off 4 sts. 1 x, 3 sts. 2 x, 2 sts. 2 x, and decrease 1 st. 1 x. Rows 143-162: *On each side of every other row decrease 1 st. 1 x and bind off 2 sts. 1 x*. Repeat from * to * 4 x. Rows 163-170: On each side of every other row decrease 1 st. 1 x, bind off 2 sts. 1 x, 3 sts. 1 x, 4 sts. 1 x, and the remaining 7 sts. Make another sleeve with reverse shapings.

NECK EDGING: Cast on 92 sts. over every other needle. Work 14 rows, making **BUTTONHOLES** after Rows 3 and 11, over the 4th - 7th needles. Bind off all sts. If your machine has 164 needles work neck edging in 2 sections by casting on 46 sts. for each section.

POCKETS AND FINISHING: Follow directions for Size 40/42.

GIRL'S CARDIGAN, No. MK 4799



SIZES: 10-11 years and 12-13 years. **MATERIAL:** Size 10-11 - 14 oz. Size 12-13 - 16 oz. **FOR EXAMPLE:** KNIT-KING Starlite Crepe or Regal Tweed. Bearbrand Casa Laine, Red Heart Nylon Wool Sport. **TENSION:** KNIT-KING 7 or 8. **GAUGE:** Stockinette Stitch 14 sts. 2", 20 rows 2"; K. 1, P. 1, Ribbing 14 sts. 2", 24 rows 2". **PATTERN:** Stockinette Stitch. **Edging:** K. 1, P. 1, Ribbing.

SIZE: 10-11. **BACK:** (Figure II). Cast on 121 sts. Rows 1-20: K. 1, P. 1, Ribbing. Continue in Stockinette Stitch.

Rows 21-116: Work even. Rows 117-204: **Raglan Shaping.** Decrease 2 sts. on each side after Row 116 and again every 4th row 21 x. To do this, put the 3rd and 4th sts. on the 5th and 6th needles and move the edge sts. over to fill the empty needles. Bind off 33 sts.

FRONT: (Figure I). Cast on 77 sts. Rows 1-20: K. 1, P. 1, Ribbing, making **BUTTONHOLES** after Row 10 over the 2nd-6th and 17th-21st needles. Continue in Stockinette Stitch. Rows 21-116: Work even, making **BUTTONHOLES** after Rows 48 and 83. Rows 117-200: **Raglan Shaping, buttonholes, and neck shaping.** Decrease 2 sts. after Row 116 and again every 4th row 20 x, following same procedure as for back. **AT THE SAME TIME**, make **BUTTONHOLES** after Rows 118 and 153. After Row 183, for the **neck shaping**, bind off 22 sts.; then on every other row bind off 2 sts. 3 x and decrease 1 st. 4 x. Then hang the 3 remaining sts. together by moving the 2 outside sts. onto the center needle and binding off. Make another front section, with reverse shapings, minus buttonholes.

SLEEVE: (Figure III). Cast on 59 sts. Rows 1-20: K. 1, P. 1, Ribbing. Continue in Stockinette Stitch. Rows 21-148: Increase 1 st. on each side after Row 26 and again every 6th row 19 x. (99 sts.). Rows 149-232: **Raglan Shaping.** Decrease

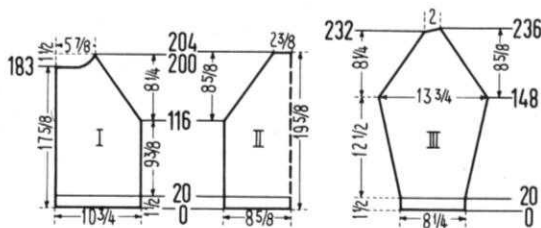

2 sts. on each side after Row 148 and again every 4th row 20 x, using same procedure as for back. Rows 233-236: On the **left side**, put 4 needles into holding position 2 x. On the **right side** decrease 2 sts. after Row 232. Bind off 13 sts. Make another sleeve with reverse shapings.

NECK EDGING: Cast on 111 sts. Work K. 1, P. 1, Ribbing: 5 rows with Tension 7, 10 rows with Tension 6, and 5 rows with Tension 7; making **BUTTONHOLES** after Rows 5 and 15 over the 7th-11th needles. Bind off all sts.

FINISHING: Weave front and back sections at side seams. Weave sleeve edges together and join sleeves to front and back sections in slip stitch, overlapping 1 st. from each section. Make a hem 11 sts. wide at front edges. Fold neck edging around cardigan neckline and attach. Finish buttonholes and sew on buttons.

SIZE: 12-13 years. **BACK:** (Figure II). Cast on 129 sts. Rows 1-20: K. 1, P. 1, Ribbing. Continue in Stockinette Stitch. Rows 21-128: Work even. Rows 129-220: **Raglan Shaping.** Decrease 2 sts. on each side after Row 128 and again every 4th row 22 x. To do this, put the 3rd and 4th sts. on the 5th and 6th needles, and move the edge sts. over to fill the empty needles. Bind off 37 sts.

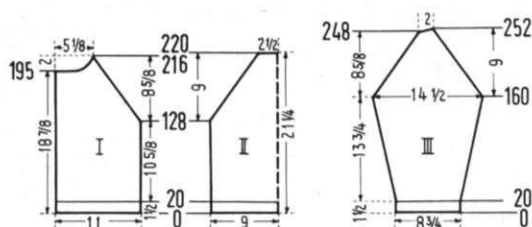

FRONT: (Figure I). Cast on 81 sts. Rows 1-20: K. 1, P. 1, Ribbing, making **BUTTONHOLES** after Row 10 over the 2nd-6th and 17th-21st needles. Continue in Stockinette Stitch. Rows 21-128: Work even, making **BUTTONHOLES** after Rows 50, 87, and 124. Rows 129-216: **Raglan shaping, buttonholes, and neck shaping.** Decrease 2 sts. after Row 128 and again every 4th row 21 x, using same procedure as for back. **AT THE SAME TIME,** make **BUTTONHOLES** after Row 161. After Row 195, for the **neck shaping,** bind off 22 sts.; then on every other row bind off 2 sts. 3 x, decrease 1 st. 6 x; then decrease 1 st. on the 4th row 1 x and hang the 3 remaining sts. together by moving the 2 outside sts. onto the center needle and binding off. Make the second front section with reverse shapings, minus buttonholes.

SLEEVE: (Figure III). Cast on 63 sts. Rows 1-20: K. 1, P. 1, Ribbing. Continue in Stockinette Stitch. Rows 21-160: Increase 1 st. on **each side** after Row 26 and again every 8th row 6 x and every 6th row 13 x. (103 sts.). Rows 161-248: **Raglan Shaping.** Decrease 2 sts. on each side after Row 160 and again every 4th row 21 x, using same procedure as for back. Rows 249-252: **On the left side,** one after another, put 4 needles in holding position 2 x. On the **right side** decrease 2 sts. after Row 248. Bind off 13 sts. Make another sleeve with reverse shapings.

NECK EDGING: Cast on 119 sts. Work K. 1, P. 1, Ribbing: 5 rows with Tension 7, 10 rows with Tension 6, and 5 rows with Tension 7, making **BUTTONHOLES** after Rows 5 and 15, over the 7th-11th needles. Bind off all sts.

FINISHING: Follow directions for Size 10-11.

CHILD'S PULLOVER, No. KK 4798



SIZE: 5-6 years. **MATERIAL:** 4 oz. blue, 3 oz. white, and 2 oz. red. **FOR EXAMPLE:** KNITKING Subita 2 x 3, Bearbrand Evermatch, Columbia Minerva Fingering. **TENSION:** KNITKING 5 or 6. **GAUGE:** 17 sts. 2", 27 rows 2". **PATTERN:** Stripe pattern on knit side according to chart. Edging: K. 1, P. 1, Ribbing.

BACK: (Figure II). Cast on 123 sts. with blue. Rows 1-16: K. 1, P. 1, Ribbing. Continue in stripe pattern following chart. Rows 17-130: Work even. Rows 131-228: **Raglan Shaping.**

On each side decrease 1 st. on every other row 4 x and on the 4th row 1 x. Repeat from * to * 7 x; then decrease 1 st. on each side of the 2nd row 1 x. Bind off 41 sts.

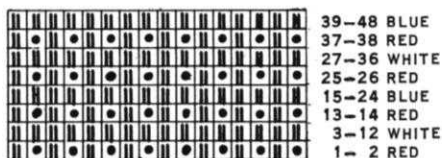

FRONT: (Figure I). The front is worked the same as the back to Row 222, with the last raglan decrease after Row 218, and for the **neck shaping,** after Row 202 bind off the 11 center sts. with a separate yarn, put needles on the left into holding position and complete the right side first. When Cam box is on neck side (every other row) bind off 4 sts. 1 x, 3 sts. 1 x, 2 sts. 2 x, and decrease 1 st. 4 x. **On each**

side hang the 3 remaining sts. together by moving the 2 outside sts. onto the center needle and binding off. Bring all needles into work, row counter back to 202 and complete the right side.

SLEEVE: (Figure III). Cast on 69 sts. with blue. Rows 1-12: K. 1, P. 1, Ribbing. Continue in stripe pattern following chart. Rows 13-30: **On each side** increase 1 st. after Row 12 and again every other row 5 x and cast on 2 sts. 2 x. (89 sts.). Rows 31-122: **Raglan Shaping.** * **On each side** decrease

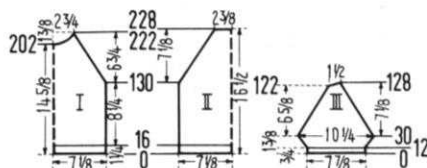

1 st. on every other row 3 x and on the 4th row 1 x; * then repeat from * to * 8 x, and on the **right side** decrease 1 st. after Rows 120 and 122. Rows 123-128: **On the left side,** put 3 needles in holding position 2 x and 4 needles 1 x. On the **right side** decrease 1 st. after Row 124. Bind off 14 sts. Make another sleeve with reverse shapings.

NECK EDGINGS: With blue, cast on 78 sts. for 1 section and 43 sts. for 1 section. Work 22 rows K. 1, P. 1, Ribbing, then bind off all sts.

FINISHING: Weave front and back sections at side seams. Weave sleeve edges together and sew sleeves to front and back sections, leaving a 2" opening on each side on the back. Make a narrow hem around these openings. Fold neck edging around sweater neckline and attach. Sew 3 loops and 3 buttons on each side for the openings.

BOY'S PULLOVER, No. KK 4797



SIZE: 7-8 years. **MATERIAL:** 7 oz. light blue, 1 oz. Bronze and 1 oz. yellow. **FOR EXAMPLE:** KNITKING Mutella, Bearbrand Evermatch, Fleishers Evermatch. **TENSION:** KNIT KING 5 or 6. **GAUGE:** Pattern Stitch 16 sts. 2", 33 rows 2"; K. 1, P. 1, Ribbing 16 sts. 2", 27 rows 2". **PATTERN:** Holding Position Design on purl side according to chart. Dial-A-Stitch machines use Wheel III. Edging: K. 1, P. 1, Ribbing. **BACK:** (Figure II). Cast on 121 sts. with Bronze. Rows 1-16: K. 1, P. 1, Ribbing: 6 rows Bronze, 4 rows yellow, and 6 rows Bronze. Continue in holding position design with light blue. Rows 17-168: Work even. Rows 169-190:

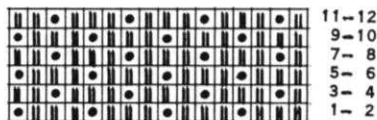

Armhole Shaping. Bind off 3 sts. beginning next 2 rows then **on each side** of every 4th row bind off 3 sts. 1 x, 2 sts. 2 x, and decrease 1 st. 2 x. (97 sts.). Rows 191-266: Work even. Rows 267-280: **Shoulder Shaping.** **On each side** of every other row bind off 4 sts. 3 x, 5 sts. 4 x, and the remaining 33 sts.

FRONT: (Figure I). Cast on 121 sts. with Bronze. Rows 1-16: K. 1, P. 1, Ribbing: 6 rows bronze, 4 rows yellow, and 6 rows Bronze. Continue in Holding Position Design with light blue. Rows 17-134: Work even. Now, on the **left side** put 55 needles into holding position and work the right section. Rows 135-168: **On the left side,** cast on 10 sts. after Row 135. To do this, put 10 sts. from the left section onto a double pointed needle or contrast yarn; and after Row 167 make **BUTTONHOLES** over the 2nd-6th and 16th-20th needles. Rows 169-190:

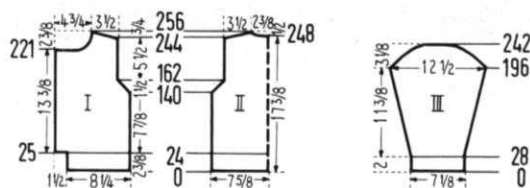
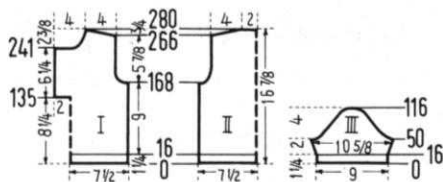

Armhole Shaping. Bind off 3 sts.; then on every 4th row bind off 3 sts. 1 x, 2 sts. 2 x, and decrease 1 st. 2 x. Rows 191-241: Work even; making **BUTTONHOLES** after Row 207. Rows 242-280: **Neck and Shoulder Shaping.** For the **neck shaping**, bind off 21 sts.; then on every other row bind off 2 sts. 2 x, decrease 1 st. 3 x; then decrease 1 st. on every 4th row 3 x and on the 6th row 1 x. **AT THE SAME TIME**, after Row 266, for the **Shoulder Shaping**, on every other row bind off 4 sts. 3 x and 5 sts. Now put the cam box on the left side and turn the row counter back to 134. Bring all needles into working position, put the sts. from the double pointed needle back onto the machine and work the left section, without buttonholes; and, on the right side cast on 21 sts. instead of 16 sts.

SLEEVE: (Figure III). (Make two). Cast on 73 sts. with bronze. Rows 1-16: K. 1, P. 1, ribbing; 6 rows bronze, 4 rows yellow, and 6 rows bronze. Continue in holding position design with light blue. Rows 17-50: Increase 1 st. on each side after Row 20 and again every 4th row 6 x. (87 sts.). Rows 51-74: **Underarm Shaping.** On each side of every 4th row bind off 4 sts. 1 x, 3 sts. 2 x, and 2 sts. 3 x. Rows 75-110: *On each side of every 4th row decrease 1 st. 1 x and bind off 2 sts. 2 x*. Repeat from * to * 2 x. Rows 111-116: On each side of every 4th row bind off 3 sts. 1 x, 4 sts. 1 x, and the remaining 9 sts.

NECK EDGING: Cast on 115 sts. with bronze. Work 24 rows K. 1, P. 1, Ribbing; 4 rows bronze, 4 rows yellow, 8 rows bronze, 4 rows yellow, and 4 rows bronze; making **BUTTONHOLES** after Rows 6 and 17 over the 6th-10th needles. Bind off all sts.

FINISHING: Weave front and back sections at side. Sew or slip st. crochet shoulder seams. Weave sleeve edges together and sew sleeves to sweater. Make a hem 10 sts. wide at front edges. Fold neck edging around sweater neckline and attach. Finish buttonholes and sew on buttons.

the right side first. When Cam box is on neck side, on every other row bind off 4 sts. 1 x, 3 sts. 1 x, and 2 sts. 1 x.

FRONT: (Figure I). Cast on 55 sts. Rows 1-24: Work in Stockinette Stitch with Tension 7 (8). To make the hem, put the cast on sts. back on the machine, and continue in Holding Position Design with Tension 8 (9). Rows 25-140: On the left side cast on 11 sts. after Row 25. Then work even. Rows 141-162: **Armhole Shaping.** On every other row decrease 1 st. 11 x. (55 sts.). Rows 163-221: Work even. Rows 222-256: **Neck and shoulder shaping.** For the **neck shaping**, bind off 20 sts.; then on every other row bind off 3 sts. 1 x, 2 sts. 1 x, decrease 1 st. 2 x; then decrease 1 st. every 4th row 2 x and every 6th row 2 x. **AT THE SAME TIME**, after Row 244, for the **shoulder shaping**, on every other row bind off 3 sts. 4 x and 4 sts. 3 x. Make the second front section with reverse shapings, making **BUTTONHOLES** after Rows 5 and 18, over the 5th-8th needles, and after Rows 57, 100, 143, and 186, over the 3rd-6th and 16th-19th needles.

SLEEVE: (Figure III). Make two. Cast on 47 sts. Rows 1-28: K. 1, P. 1, Ribbing with Tension 7 (8). Continue in holding position design with Tension 8 (9). Rows 29-196: Increase 1 st. on each side after Row 28 and again every 10th row 12 x and every 8th row 5 x. (83 sts.). Rows 197-242: **Underarm Shaping.** On each side of every other row decrease 1 st. 17 x, bind off 2 sts. 3 x, 3 sts. 3 x, and the remaining 19 sts.

NECK EDGING: Cast on 92 sts. Work Stockinette Stitch: 4 rows with Tension 7, 4 rows with Tension 6, 8 rows with Tension 5, 4 rows with Tension 6, and 4 rows with Tension 7, making **BUTTONHOLES** after Rows 5 and 18 over the 5th-8th needles. Bind off all sts.

FINISHING: Join front and back sections at side seams in slip st. crochet, overlapping 1 st. from each section. Join shoulder seams and sleeve edges together in slip st. crochet and pin sleeves in armhole then slip st. crochet. Make a hem 11 sts. wide at front edges. Fold neck edging around cardigan neckline and attach. Finish buttonholes and sew on buttons.

GIRL'S CARDIGAN, No. MK 4711



SIZE: 7-8 years. **MATERIAL:** 16 oz. blue. **FOR EXAMPLE:** KNITTING Subita 2 x 4, Spinnerin Ambralon, Bearbrand Casa Laine. **TENSION:** KNITTING Pattern Stitch 8 or 9; Stockinette Stitch and K. 1, P. 1, Ribbing 7 or 8. **GAUGE:** Pattern Stitch and K. 1, P. 1, Ribbing 13 sts. 2", 29 rows 2"; Stockinette Stitch 13 sts. 2", 20 rows 2". **PATTERN:** Holding Position Design according to chart and worn on purl side. Dial-A-Stitch machines use Wheel III. Bottom edging and neck edging:

Stockinette Stitch. Sleeve Edging: K. 1, P. 1, Ribbing.

BACK: (Figure II). Cast on 101 sts. Rows 1-24: Work in Stockinette Stitch with Tension 7 (8). To make the hem, put the cast on sts. back on the machine, and continue in Holding Position Design with Tension 8 (9). Rows 25-140: Work even. Rows 141-162: **Armhole Shaping.** On each side of every other row decrease 1 st. 11 x. (79 sts.). Rows 163-244: Work even. Rows 245-256: **Shoulder and Neck Shaping.** For the shoulder shaping, on each side of every other row bind off 3 sts. 4 x and 4 sts. 3 x. **AT THE SAME TIME**, for the **neck shaping**, after Row 248 bind off the 13 center sts. with a separate yarn, put needles on the left into holding position and complete

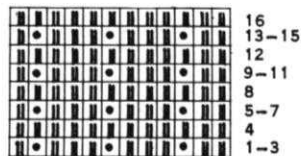

DO YOU HAVE A...

REVERSING BAR?

- With it you can turn a hem in one movement instead of lifting stitches one at a time.

- You can reverse your knitting, so that the knit side faces you, easily and speedily.

- Available for all KNITTING machines with 197 needles. Order from your dealer or direct from

KNITTING

1128 Crenshaw Blvd., Los Angeles, Calif. 90019

Price \$16.95 (California residents add 4% tax)

Plus \$1.50 shipping cost.

PRACTICAL KNITTING HINTS

COVER MODEL No. DP 7418

For those who are unfamiliar with reading an eyelet design chart, we are using our Cover Model chart as an example and to remind you that on the back cover of every KNITKING MAGAZINE is "NOTES TO KNIT BY" and at the bottom of page on the right side is a chart showing the different symbols used with our pattern charts.

Every line on the chart for DP 7418 represents 2 rows. On the first line of the chart and the first row of your knitting counting from the right edge, you will transfer the 6th stitch to the 5th needle. The open circle means that you must leave the empty needle (6) in working position. Transfer the 8th stitch to the 9th needle — and leave the empty needle in work. Transfer the 20th stitch to the 19th needle, leave the empty needle in work, the 22nd stitch to the 23rd needle, leave empty needle in work. Transfer the 34th stitch to the 33rd needle, the 36th to 37th needle. Each time be sure the empty needle is in working position. Continue to the end of the row, then knit across and back again. Now you have set up your pattern and can continue to follow the chart moving in or out using the little open circles as your guide, and each time knitting two rows. When you reach the row that shows a solid black triangle with an open circle on each side, you will transfer a stitch from each side to the center stitch which will give you 3 stitches on one needle. Another way to set up your pattern is: find the multiple of stitches used. In this case the multiple is 14 — so if you will put the 7th then every 14th needle in holding position while you follow your chart, it will make it easier for you . . . but remember to put the holding needles back in work before you knit the row. This is only a guide and you MUST remember to return your guide needles to working position.

MARKING GARMENT SECTIONS FOR EASY ASSEMBLY

When knitting sections of garments, you should, unless otherwise stated, cast on so that the "O" marking in the center of your machine is the center of the knitting. After knitting two rows, lay a strand of sewing thread of a contrasting color over the center needle if you have an uneven number of stitches, or the center two needles if you have an even number of stitches, then continue knitting. The knitted in thread will form a marking stitch to be removed easily after your garment is completed. Make the same markings in the row before taking off all stitches, or one row before starting the neckline shaping. Do the same on sleeves, neck bands, collars, skirts, etc., but remember when knitting sleeves which have a front and back shaping, your center needle will no longer be "O". To determine the center, count your stitches before the last row, then mark the middle stitch or stitches for the center.

If you plan to make a turned hem in your garment, either a skirt or jacket, it is easily marked by knitting a sewing thread loosely into your hem seam row. Before starting that row, lay a long strand of sewing thread over all the needles which are being used. Push your cam box with yarn in it as usual over the needle bed and then when you are ready to sew your hem, you have a guide line to work from and your hem will be neat and even. The thread is easily removed after the garment is completed.

When you are ready to block your garment, the center markings will be of great value and when you assemble the garment you will find the markings invaluable. The top sleeve center marking fits onto the shoulder seam. The neck markings fits to the collar markings, etc., etc., and you never have to guess again . . . try it.

HOW TO SET IN SLEEVES

The setting of a sleeve into the armholes of your garment is very important. Do a poor job and you will have a badly fitting garment. There are various ways of stitching seams together, but we recommend the following and we always insist that sections are carefully blocked before the garment is assembled.

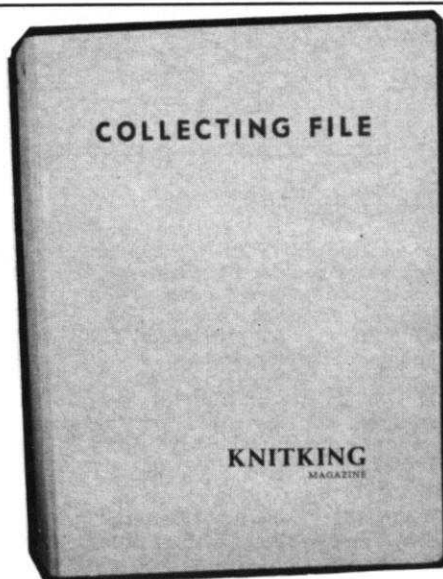

A Binder to preserve your copies of KNITKING Magazine.

Holds 12 issues available for ready reference.

Price \$2.50 each. Mailing cost 25 cents.
(California residents add 10 cents sales tax)

Available only from . . .

KNITKING MAGAZINE
1128 Crenshaw Blvd., Los Angeles, Calif. 90019

You may sew the sleeve seam using the back stitch or you can slip stitch crochet. We have a preference for the back stitch. First pin the top of the sleeve seam (which has already been joined together) to the top of the side seam of the garment making certain that the right sides of the garment are together.

Then find the center of the sleeve armholes (it can be easily identified if you follow the instructions and use an identifying thread) then pin this point to the shoulder seam of the body of the garment. Between these two secured points you will now adjust the sleeve to fit the armhole. The bottom section of the sleeve opening should be pulled just a little to accommodate the sleeve so that any excess sleeve is concentrated at the top half of the armhole (approximately 3 to 4 inches) and when you do this make sure that there are no puckers. After the sleeve is sewed in place, try the garment on to see how the sleeve fits. If everything is O.K., you may sew the second sleeve in the same manner.

It is possible to run into difficulty when sewing in sleeves if the sleeve opening does not have the same circumference as the armhole shaping on the garment. One section will have too much material while the other section will have to be stretched. If you experience this problem, you may try the following method. Leave the side seam of the garment open, but the shoulder seam intact. Now lay the front and back sections joined at the shoulder seams flat on a table. Leave the sleeve seam open and lay the flat sleeve on the armhole shaping of the front and back sections, pinning the center of the sleeve opening to the shoulder seam and the ends of the sleeve to the corresponding ends of the armhole shaping. Now you can adjust the sleeve width to the armhole width uniformly without any difficulty. If the sleeve is somewhat wider than the armhole opening (up to 1 inch in circumference can be adjusted, but no more) the surplus width should be distributed across the top half of the armhole. After the sleeve has been sewed in complete by joining the sleeve and side seams.



KNITTING NEWS

March-April, 1967

HANDY HINT

Users of our remarkable accessory, the JAC 40 and other knitters who like to knit multicolor patterns will know that it is sometimes necessary to move the slide back and forth several times in order to knit one row of stitches. They will also know that this procedure makes it difficult to keep an accurate row count. We are happy to pass on a simple, but ingenious little hint that will overcome this problem.

Most dime stores, drug stores and super markets sell for about \$1.00 a small coin adder under the registered name of Super-Add-A-Matic. It is about 4 inches long and two inches deep, red in color with three white control buttons, which when pushed in operate numbers in three small windows. These windows are marked dollars, dimes and cents. . . . This is the way you use it with your knitting machine every time you complete one actual row of knitting (irrespective of the number of times you move your cam box to do it) you push in the cents button once. When you have pushed it in ten times, a one will appear in the dime window and a zero in the cents window and when you have pushed it in one hundred times, a one will appear in the dollars window, a zero in the dimes and a zero in the cents. You can, of course, continue for as many rows as your pattern calls for. You can also use it for keeping track of your increases or decreases when shaping. The Add-A-Matic can be a very useful tool and it will save you a lot of headaches. Try it, but please do not write to us for an Add-A-Matic as we do not sell them.

LETTERS FROM READERS

Mrs. Jean Dutkowski of New Carlisle, Ohio asks. . . . "How do you put in zippers?" Some patterns call for an extra two or three stitches in width at the section where the zipper will go. If so, you fold over the extra stitches as you pin the zipper to the opening. Be careful not to stretch the knitting out of shape, pin so that each folded edge is close to the center of the zipper and baste carefully just along the outside edge of the zipper track. Remember to allow enough at the top of the opening for a collar or a facing on a sweater or dress and for a completion of a waistband at the top of a skirt. Use sewing thread (never yarn) in a color of your garment to sew the zipper in. We like to use a silk thread as it has more strength and elasticity than cotton. Now from the right side and beginning at the top, use a tiny back stitch. Bring your needle up from the wrong side to the right side and put it down through the garment to the wrong side going in back of the place where your thread came out. This must be barely a stitch, more like a pick stitch. Now bring the needle up in front of the first stitch, about 3/8 of an inch away and through to the right side. Put your needle down again in back of where your thread is as you did before, and continue in this manner. Keep your stitches in a straight line and as close to the outside zipper edge as possible. Be sure the zipper slide can move freely up and down. When you get to the bottom of the zipper, fasten off on the wrong side and start again at the top of the other side. When this is completed, take a stitch or two across the bottom edge of the zipper.

If you do not have the extra stitches to fold over allowed for in the section of the garment, it is a good idea to single crochet with garment yarn around the opening so that you will have a neat edge to work with. Be sure to split the yarn if it is of heavy weight as you do not want this edge to be bulky. Hand sew a length of seam binding to each edge of the single crochet and turn back to the inside for a base for sewing your zipper. You may also like to sew a piece of seam binding by hand over the zipper tape on the wrong side, then tack very loosely in place and it will have that professional look which we all strive for...

SUBSCRIPTIONS TO KNITKING MAGAZINE

Despite the repeated warnings we include in the pages of the magazine, many readers still believe that the Post Office will forward the magazine to them when they change their address because they completed a mail forwarding card..... it is not so..... KNITKING MAGAZINE goes out as third class bulk mail and third class bulk mail is not forwarded to a changed address. Many subscribers who change their address blame us if the magazine is not forwarded to them and state that all their other mail is forwarded. They admit that they didn't notify us of the change in address because they didn't believe it necessary.... They almost always demand that we replace the missing issues, even though the fault is not ours. Sometimes we have run out of certain issues and cannot replace them anyway. So.... please.... save yourself and us a headache.... Send notification of your change of address before you make it.

SPECIALS

We have a really sensational "SPECIAL" on the factory close-out yarn we told you about in the last edition of KNITKING NEWS.

Despite the fact that we have over two tons of the yarn available, it will go very quickly....so don't delay getting your order in and be sure to give two alternate color choices. One half of our stock will be held back for a period of two weeks in order to give Eastern readers time to get their magazines and place their orders. We suggest that readers east of the Mississippi send orders in by airmail.

There are two types of yarn available. 'Parisienne' is an excellent nubby two color mixture (the second color is always white) ideal for dresses, blouses or suits, etc. 'Tivoli' is a very attractive two color slub (light nub) yarn and again the second color is always white. Both yarns are a mixture of linen, cotton and viscose which means that garments made from them are cool, good looking, hard wearing and easily washed.

The only way for us to sell these top quality yarns at our ridiculously low special price is for us to handle them as little as possible. We are therefore offering this yarn by the package ONLY.... Yarn of this quality would normally sell for around \$1.00 an ounce, but we are offering it at the fantastically low 25¢ an ounce if you purchase a minimum of two unbroken packages. Each package

contains 20 skeins (35 ounces). Two packages will contain a total of 70 ounces and cost only \$17.50 plus shipping costs and if you are a California resident, 70¢ sales tax. Imagine...you will pay only \$17.50 for 70 ounces of yarn that would normally cost around \$70.00.

Each package will contain only one color mixture, but you can order a package in 'Tivoli' and a package in 'Parisienne' or two packages of either, always remembering that each individual package can only contain one color. Both yarns knit at 5 to 6 1/2 stitches to the inch, depending on the tension or needle size used. You can of course, purchase as many packages as you wish. The shipping costs are \$1.25 for two packages and the colors (no samples available) are as follows:

<u>TIVOLI</u>		<u>PARISIENNE</u>	
<u>Color</u>	<u>Number</u>	<u>Color</u>	<u>Number</u>
Goldenrod	T.1	Plum	P.1
Peony Pink	T.2	Lavender	P.2
Spring Green	T.3	Cognac Gold	P.8
Toast	T.4	Spring Green	P.9
Grapefruit	T.5	Peony Pink	P.10
Peachblossom	T.6	Hyacinth Blue	P.11
Light Plum	T.8	Goldenrod	P.12
Lime Green	T.9	Emerald Green	P.13
Pink Dogwood	T.10	Pink Dogwood	P.14
Emerald Green	T.11		
Lavender	T.12		
Cognac Gold	T.14		
Hyacinth Blue	T.15		

DON'T FORGET to give two alternate colors and REMEMBER the shipping costs \$1.25 for two packages, plus 70¢ sales tax if you live in California.

Over

BACK ISSUES OF KNITKING MAGAZINE

The demand for back issues of KNITKING MAGAZINE grows as our subscription list increases..... Because of this, certain of the issues are completely sold out and many of the others are in extremely low supply..... Bound editions of the First Volume were sold out many months ago, but we still have some single copies of issues 1, 2, 4, 5 and 6.

There are a very few bound and plastic covered editions of the Second Volume still available for \$6.95 - postage paid anywhere in America, and some single copies of 1, 2, 3 and 4 can still be obtained, although 3 and 4 are in very low supply..... No. 1 of Volume 3 is sold out and editions 2 and 3 are already in very low supply.

Single copies of available issues can be obtained direct from KNITKING for \$1.50 each postpaid....or at the special rate of any 6 issues (over 120 patterns) for \$6.00 postage paid.

NOTES TO KNIT BY . . .

STITCH AND ROW GAUGE

The stitch and row gauge is the number of stitches and the number of rows you get to the inch with the yarn recommended for any particular garment. To arrive at the correct number of stitches and rows, you must prepare a sample swatch as follows: Cast on the number of stitches that will give you a finished width of at least 4 inches. Using the suggested stitch tension in your pattern, knit a length of at least 4 inches. Knit 2 rows of a contrast yarn. Set your tension one number higher and knit another 4 inches. Knit 2 rows of contrast color. Set your tension 1 number lower than the suggested one and knit a further 4 inches. Now bind off.

For years people have been told to steam their sample swatch and for years we have been getting reports from people telling us that although the sample swatch was correct, the finished garment was too small or too large. Others have complained that even when they used the suggested yarns they had to use a much larger or smaller tension to make a swatch and then the finished garment came out the wrong size anyway.

Obviously it is possible for two people to pin an identical swatch and steam it and get a totally different result. One will stretch the sample before pinning it, and the other will squeeze it in. We have discovered a way that produces the same result with everybody, and we recommend that you get into the habit of always using it.

After knitting the sample and removing it from the machine, roll it into a cylinder over its length, then pull on both ends. Unroll the cylinder and stretch the sample diagonally by pulling on the four corners. Now let it rest — give it an opportunity to resettle for at least a few hours, preferably over night. After you and your swatch have rested, lay your stitch gauge on it and count the number of stitches in your 2 inch marking. Do the same for the number of rows. If you did not get the correct gauge in your first section of knitting, try the section either 1 tension higher or lower as the case may be. If you cannot get the correct gauge, then you are using the wrong type of yarn for the garment.

NON-WORKING POSITION

The needles are in the non-working position when they are as far back on the needle bed as they will go.

HOLDING POSITION

The Holding Position is as far forward on the needle bed as your needles will go. The Holding Position is used for producing pattern designs, fancy stitches and the knitting of short rows.

SHORT ROWS

Short rows are used for shaping of all kinds such as toes and heels of socks, collars, darts and sometimes in the shaping of shoulders, borders and full skirts. To knit short rows you push the needles forward into the holding position as specified in the pattern instructions, usually working from the outside in, which in effect narrows the width of the knitting as you proceed. Before knitting each row, you **must** place the yarn between the first and second inside needles that are in the holding position.

INCREASING, DECREASING, BINDING OFF

See the Instruction Manual for your own machine.

INCREASING AND DECREASING WHEN USING THE RIBBER

When increasing, increase on the main knitter first, knit one row and then transfer the necessary stitches from the knitter to the ribber and continue.

When decreasing or binding off, you must transfer the ribber stitches to the main machine before decreasing or binding off.

ADJUSTING SKIRT LENGTHS, ETC., TO SUIT YOUR OWN SIZE

If you are shorter or taller than average, you will need to adjust certain of the garment lengths. You do this by reducing or increasing the number of rows called for in the pattern.

The reduction in the rows is usually made at the bottom of a skirt or dress. The procedure is very simple. If for example you need a skirt length 2 inches shorter than the one shown in our pattern, and the yarn called for produces 9 rows to the inch, you will need to reduce the number of rows by 18. Many of our patterns are shaped to curve in a small amount toward the bottom and the bottoms frequently have a turned hem. In such cases, the reduction or increase in the number of rows required should be made immediately after the turned hem. If you are long waisted or short waisted you may have to make an adjustment at the waistline.

READING OF KNITTING PATTERNS AND SYMBOLS

Certain holding position and eyelet designs are sketched in the knitting patterns. The pattern should be read as the work comes toward you from the machine, that is, if you have purl stitches before you, it will say purl stitches in the pattern. If you have knit stitches before you it will say knit stitches in the pattern. On the sides of the pattern are the row numbers. Missing row numbers indicate that the rows are to be worked evenly. In eyelet design patterns, specified stitches are transferred to another needle and the empty needles are returned to the knitting position each time. In holding position designs, selected needles are pushed into the holding position for the stated number of rows.

MISSING ROW NUMBERS

When there are row numbers missing in the instructions as for instance when you have completed the designated increases or decreases on a section of garment, continue straight knitting until you reach the next given row number.

Control Knobs (Under the slide handle — one on each side on KNITKING and certain other machines.)

1. When BOTH Control Knobs are UP, knit one row going from right to left. The needles knit and move back just beyond the front of the needle bed and the yarn hangs on the front of the needles. The slide will now move freely in either direction with the needles remaining in a "SAFE POSITION." When you wish to resume knitting, press down BOTH Control Knobs. The first movement of the slide is made without yarn and will bring the needles into working position, you then continue knitting.

2. **Right Control Knob UP.** Knit from right to left. The row knits, moves the needles back and the yarn is held in front of the latches. Knit from left to right, the yarn goes under the needles without knitting as the needles move into the working position. This is the operation used for making round cords (with 3 or 4 needles only) and also for knitting single rows of one color.

3. **Left Control Knob UP.** The same as above but moving from left to right.

PATTERN STITCH SYMBOLS

- = knit stitch
- = purl stitch
- = empty needle (leave in working position)
- ⊗ = needle not used (in the out of work position)
- = needle in holding position
- ⊠ = 2 stitches on 1 needle — either transferred from the right side or the left side, then put the needle into holding position
- ⊡ = needle holding 2 sts. Stitch has been transferred from the LEFT
- ⊢ = needle holding 2 sts. Stitch has been transferred from the RIGHT
- ⊣ = 3 stitches on 1 needle. The 1st and 3rd stitch in a group of 3 needles has been hung on the 2nd or center needle.

The diagrams for pattern work are followed just as they are shown, and on your knitting as it comes towards you on the machine.

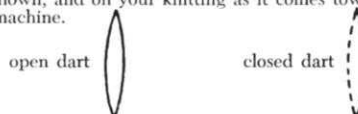

**What's the only knitting machine
better than a Knitking?**

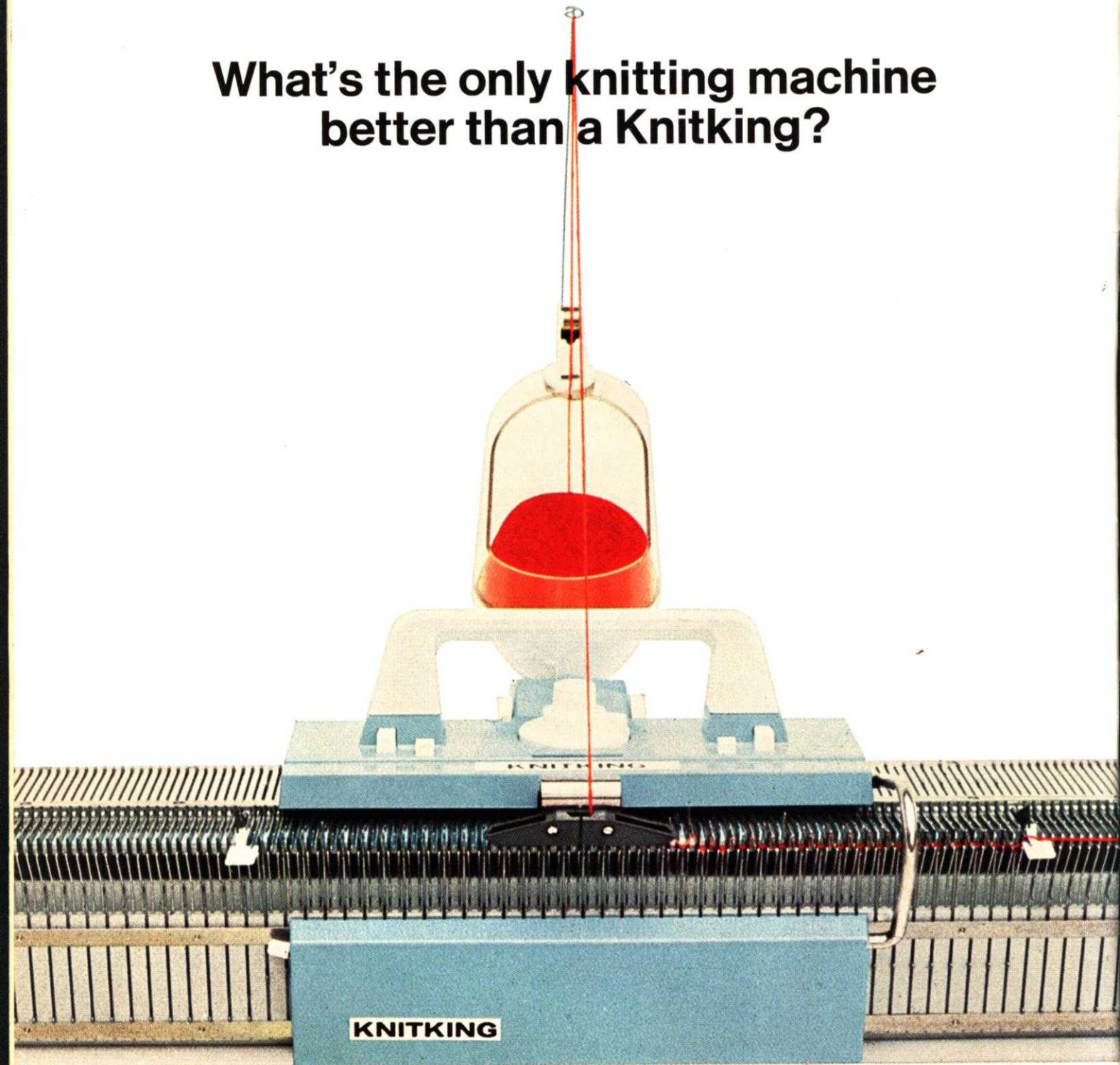

The new  Knitking!

For color brochure and complete details on this magnificent new KNITKING write to:
KNITKING • 1128 Crenshaw Blvd., Los Angeles, California 90019