

knitking

magazine

sept/oct '70



Accessories

1. Treble Transfer-Tools. For rapid transfer of stitches and for cable stitch. \$1.50 pair plus 25c shipping.
2. Yarn Winder and Skein Holder. Heavy cast frame and nylon gears. \$15.95 plus \$1.00 shipping.
3. 33 Needle Multi-Transfer Tool. For decreasing in the middle of a row. \$3.25 plus 25c shipping.
4. Adjustable Needle Selector. For setting unevenly spaced pattern stitches. \$3.50 plus 25c shipping.

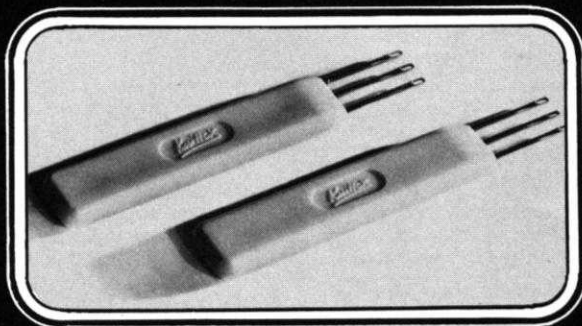

5. Reversing Bar. For easy hem turning or reversing of knitting. \$17.95 plus \$1.50 shipping.
6. Automatic Pattern Selector. For all KNITTING machines prior to Push Button. \$7.95 plus 35c shipping.
7. Converta Tape. For simple and speedy charting of custom knits. \$6.95 plus 30c shipping.

California residents add
5% sales tax.

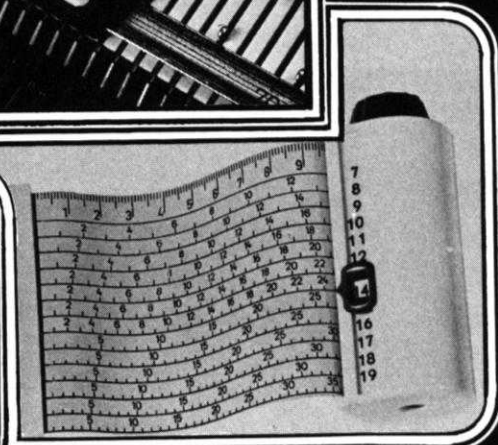
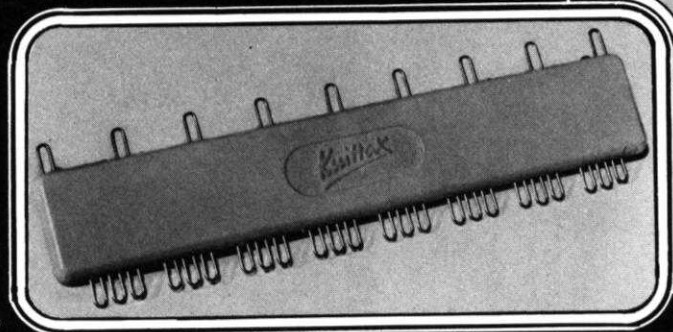
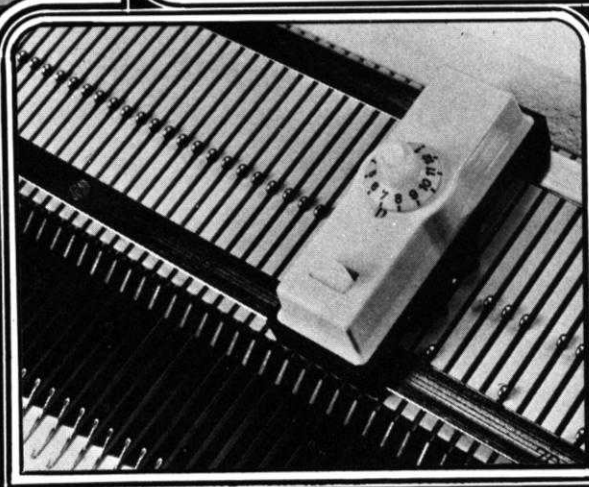
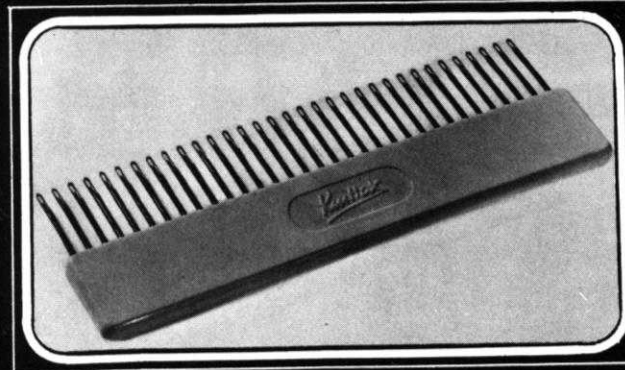
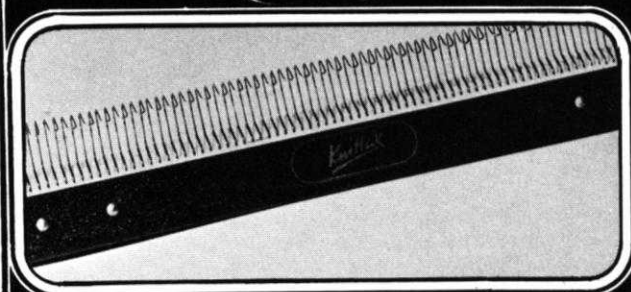
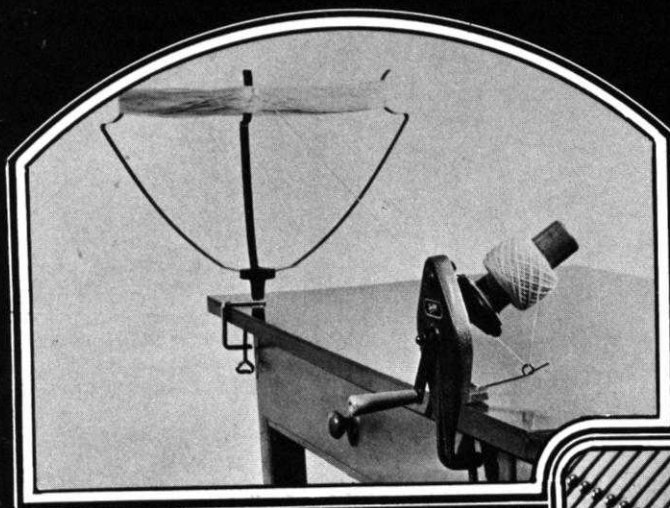

knitking

magazine

INDEX	PAGE NO.
DK 7872	Woman's two piece Suit 14
DP 7873	Woman's Pullover 15
MK 5238	Girl's two piece Suit 16
MK 5239	Girl's Pullover 16
DK 7875	Woman's Jumper 18
MK 5241	Girl's Jumper 19
HP 3617	Man's Pullover 20
KK 5243	Boy's Pullover 21
DK 7874	Woman's two piece Suit 22
HP 3618	Man's Pullover 24
HP 3632	Man's Jacket 25
DP 7915	Woman's Jacket and Shell 26
DP 7912	Woman's Pullover and Cardigan 28
MK 5264	Girl's Dress 29
MK 5265	Girl's Dress 30
KG 1910	Socks for the family 31
KG 1911	Puppet Mittens 32

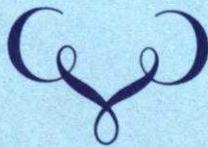

We've arrived!!! . . . With the lucky number 7 for our next years publication of KNITKING MAGAZINE we introduce the brand new range of beautiful KNITKING YARNS . . . We aim to give you more of what you ask

for in the way of current styles — plus hints galore and quickie gifts . . . Mother and Daughter make the Fashion Scene together on our Cover . . . Each is wearing a two piece Suit with a short double breasted Jacket. Short rows are used to knit the full skirts and a Holding Position design makes the pattern stitch. Knitted with KNITKING Conchita and worn on the purl side. See pages 14 and 16.

Publisher: KNITKING CORPORATION, 1128 Crenshaw Blvd., Los Angeles, Calif. 90019. Telephone: WEbster 8-2079. Published bi-monthly. Subscriptions: USA — \$6.00 annually, single copies \$1.50; Canada — \$7.00; other parts of the world — \$10.00. The entire contents of KNITKING MAGAZINE are copyright and must not be reproduced in any shape or form without the express permission, in writing of the publisher. COPYRIGHT © by KNITKING CORPORATION 1970.

Printed by George Rice & Sons, Los Angeles, California

knitking

magazine

It is difficult to believe that we are, with this issue, beginning our seventh year of publication . . . It seems such a short time ago that we introduced, with great pride (and no little trepidation because of the substantial financial risk involved) the very first edition of KNITKING MAGAZINE . . .

Many charter subscribers have stayed with us and we are sure that they (like us) realize how tremendously KNITKING MAGAZINE has improved since the first issue . . . Credit is due in no small part to the hundreds of readers who write with comments and suggestions and who graciously take the time to complete the various questionnaires that we send out . . . We can only provide you with the answers to your knitting questions and supply the type of patterns you want if you ask . . . So in the words of a world famous entertainer "keep those cards and letters coming in folks."

When we introduced KNITKING MAGAZINE, we used national brand name yarns for our garments, but it was not long before we decided that to avoid the time consuming task of testing many brands of yarn in order to select those suitable for KNITKING garments, we would have to obtain exclusive top quality yarns suitable for our purpose and offer them to our readers under the KNITKING name.

Since that time, it seems that we have knitted thousands of balls and hundreds of different types of yarns . . . For a while it seemed that (because so many yarns were being rejected) we had set our standard a little too high, but we maintained our standard and slowly but surely, selected an assortment of yarns that are second to none. The garments in this issue were made with some of them and they are all displayed in our big beautiful new yarn catalogue . . . Be sure to order a catalogue and see for yourself how gorgeous they really are.

We have some outstanding garments ready for the next issue . . . The cover features a long sleeved sporty dress with a mock turtle neck and jacquard designs on the body. There is another smart casual dress with a V-neck and wrap-over front . . . and in response to many requests, we are also featuring three attractive pants suits plus a two piece eyelet design skirt suit and an assortment of handsome winter sweaters for every member of the family . . . The gift section will have several fun things for Christmas giving . . .



DP 7873 and MK 5239

Complement . . . Elegant Pullovers for Mother and for Daughter are to be worn with the Suits shown on the cover. The holding position design follows a line drawing. Wear them on the purl side. Use KNITTING Conchita. DK 7873 Size 10/12; MK 5239 6 to 7 years. See pages 15-16.



DK 7875 and MK 5241

Almost identical Mother and Daughter Jumpers are perfect for fall and winter wear. Beautifully designed with Cables on the front sections. Ribbed bands, zippered closures and large sized pockets complete the picture. The yarn is machine washable KNITTING Crocus. DK 7875 Size 12/14, MK 5241 Size 8 to 9. See pages 18-19.



KK 5243 and HP 3617

Fly Right! For the Men in your family. Father and Son wear identical ribbed, V-necked Pullovers with saddle shoulders and a small cable design on the front and back sections. 1 x 1 ribbing for all bands. Use KNITKING Amore. KK 5243 Size 6 to 8. See page 21. HP 3617 Size 40/42. See page 20.



DK 7874

An elegant Suit has an "A" Line Skirt. Cables are on the front and back sections of the deep ribbed Jacket. The saddle shoulders and high ribbed, buttoned Collar are especially attractive. Use KNIT-KING Troyer Tweed. Size 12/14. See page 22.

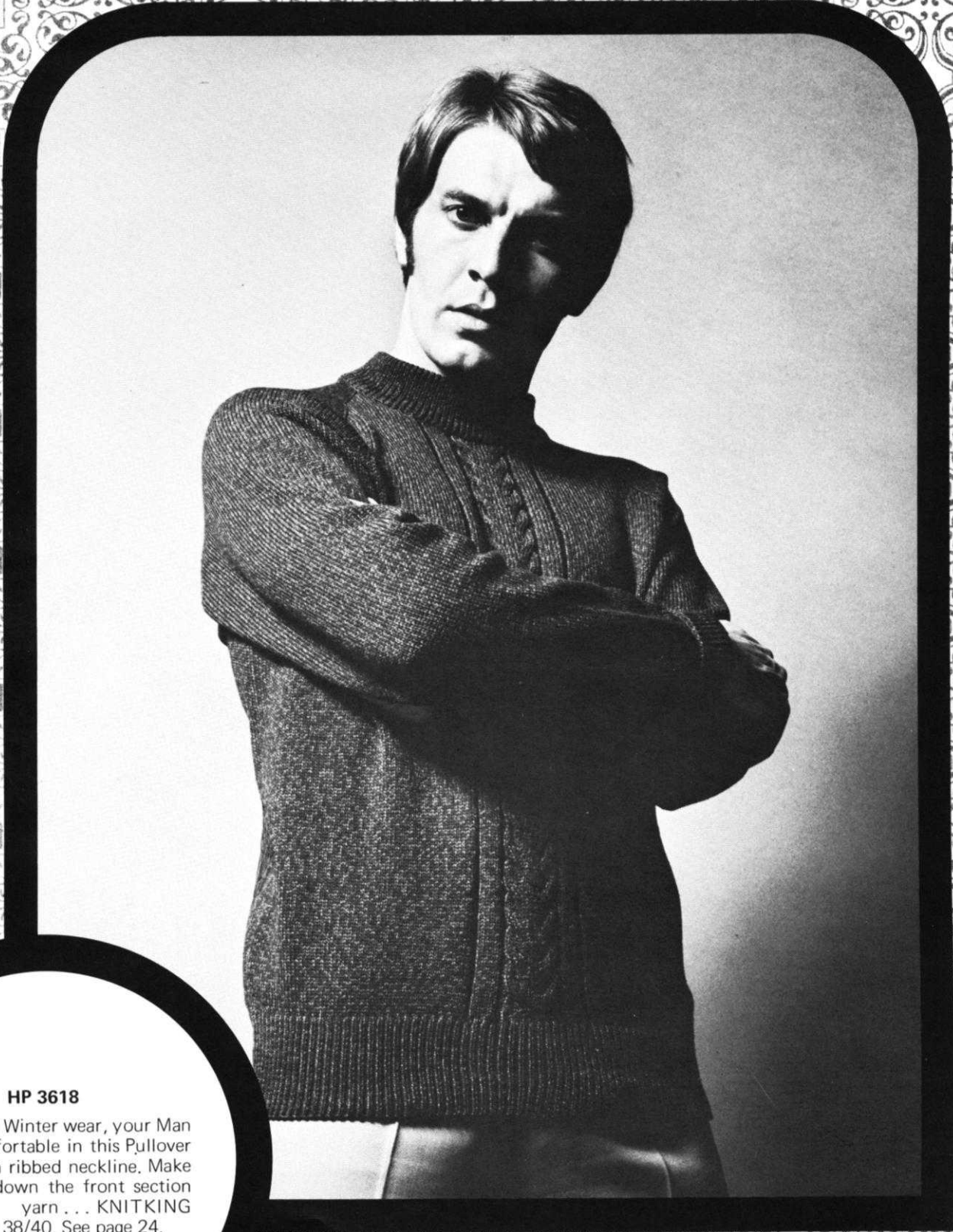

HP 3618

For Fall and Winter wear, your Man will be comfortable in this Pullover with its high ribbed neckline. Make the Cables down the front section only. The yarn . . . KNITKING Lovely. Size 38/40. See page 24.



HP 3632

Knit your Man this excellently styled Jacket. Rib the edges and zip the front, then give him a bright scarf to drape at the neckline. KNITKING Crocus. Size 42/44. See page 25.



DP 7915

Stripe the Shell and knit the Cardigan in a plain color for a smart Fall Twin-set. Use 3 colors of KNIT-KING Subita Dralon for the Shell — main color for the Cardigan. Size 14/16. See page 26.





DP 7912

Match-mates . . . The popular Chanel type Jacket is worn over a short sleeved Pullover. Both have colorful striping at lower edge. 3 colors of KNITKING Crocus is the yarn. Size 12/14. See page 28.



MK 5264

Here is a school-girl fashion she'll adore wearing. The belted waistline is very new and the front has a zippered closure. Knit it with 3 colors of KNITKING Crocus. Size 12/13. See page 29.



MK 5265

Hurray for School... A darling school dress will make any girl happy. 5 colors of KNITKING Subita Crepe 2 x 3 are used... The Yoke is striped and has a tab trim on the left shoulder. Size 10 to 11. See page 30.



KG 1911

Delight a small child with some crazy Puppet Mittens. Make them as shown, then let your imagination take over for other animal trims. Easy to knit using KNITKING Leacril. See page 32.



KG 1910

SOCK IT TO THEM! From Infants to Grand-pop, Socks make a tremendous hit. We give you a wide range of sizes knitted in stockinette stitch...but remember you can always add your own pattern stitch, JAC 40 Design, or stripes on the leg and instep. KNITKING Fortissima is the yarn. See page 31.

DP 7873

SIZE: 10/12 MATERIAL: 12½ oz. (7 balls) pale blue KNITTING CRYLOR Conchita. TENSION: KNITTING 4 to 6. GAUGE: Pattern stitch 15 sts, 2" 28 rows 2". PATTERN: Holding Position Design according to Line Drawing, worn on the puri side. EDGES: K1, P1, Ribbing. INCREASES: After rows indicated, move the 1st st. ON EACH SIDE 1 needle outward, then place the 2nd st. from the row below onto the empty needle.

FINISHING: Block all sections to measurements given. Join front and back section at sides and shoulders, easing in the fullness at bustline of front section. Sew sleeves together and set in. Join short ends of collar, then sew 1 edge of collar to inside and 1 edge to outside of neckline.

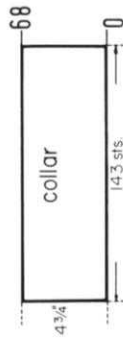
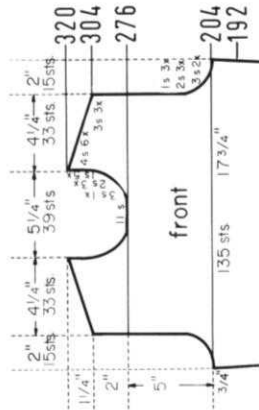
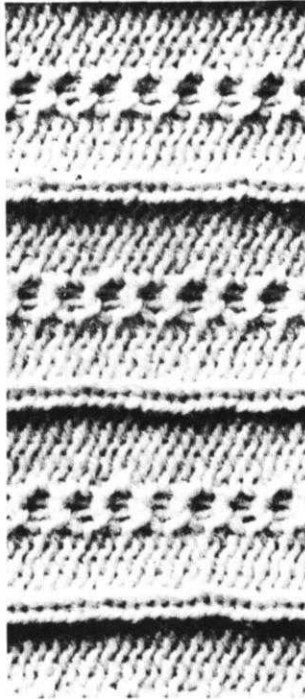

Cast on 143 sts. and work 68 rows K1, P1, Ribbing, then bind off all sts. the crochet method for ribbing.

Bring the needles on the left side into working position, knit 1 row in PATTERN to the left side, turn the Row Counter back to 292 and complete the left half. Follow the instructions from *.

* ON CAM BOX SIDE, bind off 3 sts. after Row 292 (EVEN ROWS = SHOULDER SHAPING), 294, 295, 296; 2 sts. after Row 297; 4 sts. after Row 298; 2 sts. after Row 299; 4 sts. after Row 300; 2 sts. after Row 301; 4 sts. after Row 302; 2 sts. after Row 303; 4 sts. after Rows 304, 306, 308.

ON CAM BOX SIDE, bind off 3 sts. after Rows 192, 193, 194, 195; 2 sts. after Rows 196, 197, 198, 199, 200, 201; 1 st. after Rows 202, 203, 204, 205, 206, 207, then knit to Row 292, bind off the center 11 sts., put the needles on the left side into holding position (transfer the ribber sts.) and complete the right half first.

ON EACH SIDE, increase 1 st. after Rows 74, 104, 134, 164, then knit to Row 192.

ROWS 0 to 18: Knit even, then transfer the appropriate ribber sts. to the main machine and work the Holding Position Design.

Cast on 127 sts. and work K1, P1, Ribbing.

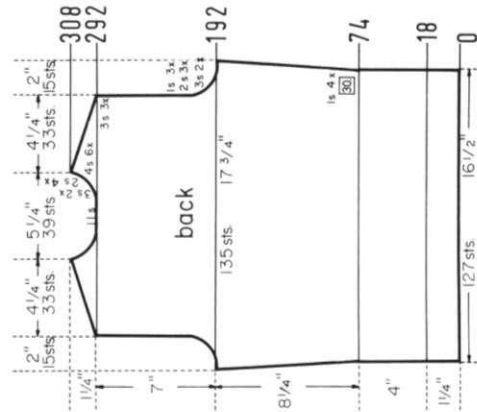

Bring the needles on the left side into working position, knit 1 row in PATTERN to the left side, turn the Row Counter back to 276 and complete the left half. Follow the instructions from *.

* ON CAM BOX SIDE, bind off 3 sts. after Row 277 (ODD ROWS = NECK SHAPING); 2 sts. after Rows 279, 281, 283; 1 st. after Rows 285, 287, 289, 291, 293. For SHOULDER bind off 3 sts. after Rows 304, 306, 308; 4 sts. after Rows 310, 312, 314, 316, 318, 320.

ON CAM BOX SIDE, bind off 3 sts. after Rows 204, 205, 206, 207; 2 sts. after Rows 208, 209, 210, 211, 212, 213; 1 st. after Rows 214, 215, 216, 217, 218, 219, then knit to Row 276, bind off the center 11 sts., put the needles on the left side into holding position (transfer the ribber sts.) and complete the right half first.

ROWS 193 to 204: Knit even.

Work the front section the same as the back section to ROW 192.

ON CAM BOX SIDE, bind off 3 sts. after Rows 58, 59, 60, 61; 2 sts. after Rows 62, 63, 64, 65, 66, 67, 68, 69. ON EACH SIDE, hang the 1st st. onto the 2nd st. after Rows 70, 72, 74, 76, 78, 80, 82, 84, 86, 88, 90, 92, 94, 96, 98, 100, 102, 104, 106, 108, 110. ON CAM BOX SIDE, bind off 2 sts. after Rows 112, 113, 114, 115; 3 sts. after Rows 116, 117, 118, 119; 9 sts. after Row 120.

ON EACH SIDE, increase 1 st. after Rows 18, 22, 26, 30, 34, 38, 42, 46, 50, then knit to Row 58.

ROWS 0 to 18: Knit even then transfer the appropriate ribber sts. to the main machine and work the Holding Position Design.

Cast on 81 sts. and work K1, P1, Ribbing.

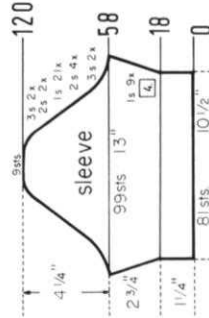

BE SURE TO NOTIFY US IMMEDIATELY OF ANY CHANGE OF ADDRESS. THE POST OFFICE WILL NOT FORWARD YOUR MAGAZINE TO YOU.

SIZE: 6-7 (Chest 24"-25"). MATERIAL: 14 oz. (8 balls) dark blue KNITTING Crylor Conchita. TENSION: KNITTING 5 to 7. GAUGE: Stockinette Stitch 15 sts, 2", 24 rows 2". Holding Position Design 15 sts, 2", 40 rows 2". PATTERN: Jacket: Stockinette Stitch; Skirt: Stockinette Stitch and Holding Position Design Stripes according to Line Drawing. The purl side on all sections is the right side. INCREASES: After rows indicated, move the 2 end sts. on the appropriate sides 1 needle outward, then place the 3rd st. from the row below onto the empty needle. The Skirt is knitted sideways and the bell-shape is obtained by knitting Short Rows. The finished length of the skirt is 11 1/2".

FINISHING: Block all sections to measurements given. SKIRT: Weave the sts. held on contrast yarn together, leaving about 3" on the upper part free for the opening. Bind these sts. off. Sew 1 edge of waist band to inside and 1 edge to outside of upper edge easing in the fullness of the skirt. Insert an elastic band and sew to short ends of waist band. Sew in a zipper. Turn under 2" on lower edge and hem to wrong side. JACKET: Join front and back sections at sides and shoulders. Sew sleeves together and set in. Turn under 1" on sleeve edges and hem to wrong side. Work 2 rows of single crochet around front edges and neckline. Turn under 17 rows on lower edge and hem to wrong side. Insert an elastic band and sew to front edges. Finish buttonholes, sew on buttons.

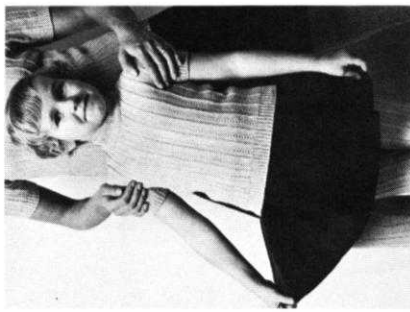

SIZE: 6-7 (Chest 24"-25"). MATERIAL: 7 oz. (4 balls) pale blue KNITTING Crylor Conchita. TENSION: KNITTING 4 to 6. GAUGE: Pattern Stitch 15 sts, 2", 28 rows 2". PATTERN: Holding Position according to Line Drawing, worn on the purl side. EDGES: K1, P1, Ribbing.

FINISHING: Block all sections to measurements given. Join front and back section at sides and shoulders. Sew sleeves together and set in. Join short ends of collar, then sew 1 edge of collar to inside and 1 edge to outside of neckline.

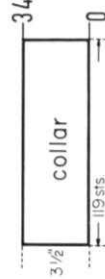
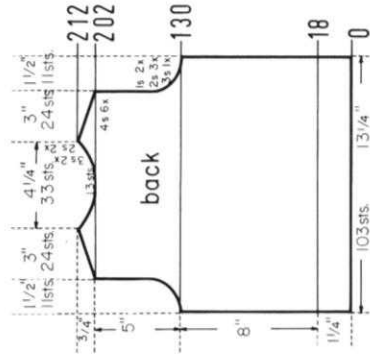

Cast on 119 sts. and work 34 rows K1, P1, Ribbing, then bind off all sts. the crochet method for ribbing.

Bring the needles on the left side into working position, knit 1 row in PATTERN to the left side, turn the Row Counter back to 202 and complete the left half. Follow the instructions from *.

* ON CAM BOX SIDE, bind off 4 sts. after Row 202 (EVEN ROWS = SHOULDER SHAPING); 3 sts. after Row 203 (ODD ROWS = NECK SHAPING); 4 sts. after Row 204; 3 sts. after Row 205; 4 sts. after Row 206; 2 sts. after Row 207; 4 sts. after Row 208; 2 sts. after Row 209; 4 sts. after Rows 210, 212.

ON CAM BOX SIDE, bind off 3 sts. after Rows 130, 131; 2 sts. after Rows 132, 133, 134, 135, 136, 137; 1 st. after Rows 138, 139, 140, 141, then knit to Row 202. (For Front Section knit to Row 174). After Row 202 bind off the center 13 sts., put the needles on the left side into holding position and complete the right half first.

ROWS 19 to 130: Knit even.

ROWS 0 to 18: Knit even, then transfer the appropriate ribber sts. to the main machine and work the Holding Position Design.

Cast on 103 sts. and work K1, P1, Ribbing.

Work the left front section with reverse shapings, casting on from left to right. (Cam Box will be on the RIGHT side at Row 0). Omit the buttonholes.

ON CAM BOX SIDE, bind off 5 sts. after Row 105 (ODD ROWS = NECK SHAPING); 3 sts. after Row 106 (EVEN ROWS = ARMHOLE SHAPING); 4 sts. after Row 107; 3 sts. after Row 108; 4 sts. after Row 109; 3 sts. after Rows 110, 111; 2 sts. after Row 112; 3 sts. after Row 113; 2 sts. after Rows 114, 115; 1 st. after Row 116; 2 sts. after Row 117; 1 st. after Row 118 (last time for Armhole); 2 sts. after Row 119; 1 st. after Rows 121, 123, 125, 127, 129, 131, 135, 139, 143, 147, 151. For SHOULDER, bind off 4 sts. after Rows 172, 174, 176, 178, 180, 182.

ON OPPOSITE SIDE of CAM BOX make buttonholes after Rows () over the 5th-8th and 30th-33rd sts. counting from the right side. ON CAM BOX SIDE, increase 1 st. after Rows 34, (38), 52, 70, (70), 88, (102), then knit to Row 105.

ROWS 0 to 34: Knit even.

From right to left cast on 71 sts. and work stockinette st. (Cam Box will be on the LEFT side at Row 0).

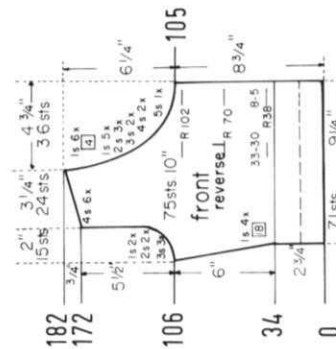

Move the Cam Box to the left side, turn the Row Counter back to 172 and complete the left half. Follow the instructions from *.

* ON CAM BOX SIDE, bind off 4 sts. after Row 172 (EVEN ROWS = SHOULDER SHAPING); 3 sts. after Row 173 (ODD ROWS = NECK SHAPING); 4 sts. after Row 174; 3 sts. after Row 175; 4 sts. after Row 176; 3 sts. after Row 177; 4 sts. after Row 178; 3 sts. after Row 179; 4 sts. after Row 180, 182.

ON CAM BOX SIDE, bind off 3 sts. after Rows 106, 107, 108, 109, 110, 111; 2 sts. after Rows 112, 113, 114, 115; 1 st. after Row 116, 117, 118, 119, then knit to Row 172, bind off the center 12 sts., put the needles on the left side into holding position and complete the right half first.

ON EACH SIDE, increase 1 st. after Rows 34, 52, 70, 88, then knit to Row 106.

ROWS 0 to 34: Knit even.

Cast on 106 sts. and work stockinette st.

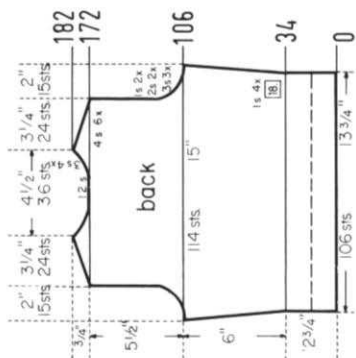

Repeat Rows 0 to 74 10 x, but on the last repeat knit only 73 rows. After Row 813 knit several rows with contrast waste yarn, then remove knitting from machine.

ROWS 59 to 74: Work the Holding Position Design (work Line Drawing Rows 2 x).

ROWS 49 to 58: Work stockinette st. over all 96 sts.

ROWS 11 to 48: Work Short Rows. ON OPPOSITE SIDE of CAM BOX put into holding position 66 needles, then knit 2 rows. ON OPPOSITE SIDE of CAM BOX bring back into working position 7 needles after Rows 12, 14, 16, 18, 20, 22, 24, 26, 28. (3 needles remain). ON OPPOSITE SIDE of CAM BOX put into holding position 7 needles after Rows 30, 32, 34, 36, 38, 40, 42, 44, 46. After Row 48 bring all needles back into working position.

ROWS 0 to 10: Work stockinette st. and knit even.

With contrast waste yarn cast on 96 sts. and knit several rows, ending with the Cam Box on the right side. Change to garment yarn and turn Row Counter to 0.

Cast on 180 sts. and work 24 rows stockinette st., then bind off all sts.

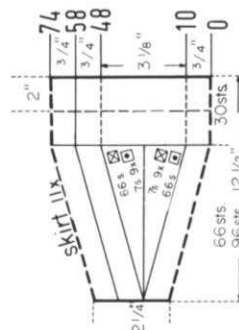
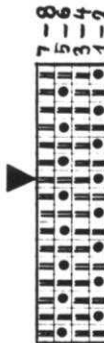

Bring the needles on the left side into working position, knit 1 row in PATTERN to the left side, turn the Row Counter back to 174 and complete the left half. Follow the instructions from *.

* ON CAM BOX SIDE, bind off 2 sts. after Rows 175, 177, 179, 181 (ODD ROWS = NECK SHAPING); 1 st. after Rows 183, 185, 187, 189. For SHOULDER bind off 4 sts. after Rows 202, 204, 206, 208, 210, 212.

Work the front section the same as the back section to Row 174, then bind off the center 9 sts., put the needles on the left side into holding position and complete the right half first.

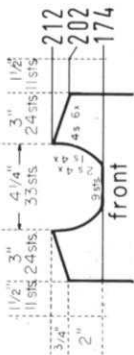

ON CAM BOX SIDE, bind off 3 sts. after Rows 34, 35; 2 sts. after Rows 36, 37, 38, 39, 40, 41. ON EACH SIDE, hang the 1st st. onto the 2nd st. after Rows 42, 44, 46, 48, 50, 52, 54, 56, 58, 60, 62, 64, 66, 68, 70. ON CAM BOX SIDE, bind off 2 sts. after Rows 72, 73, 74, 75; 3 sts. after Rows 76, 77; 7 sts. after Row 78.

ON CAM BOX SIDE, increase 1 st. after Rows 12, 13, 20, 21, 28, 29, then knit to Row 34.

ROWS 0 to 12: Knit even then transfer the appropriate ribber sts. to the main machine and work the Holding Position Design.

Cast on 63 sts. and work K1, P1, Ribbing.

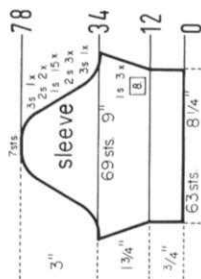

ON CAM BOX SIDE, bind off 4 sts. after Rows 152, 153; 3 sts. after Rows 154, 155, 156, 157; 2 sts. after Rows 158, 159, 160, 161. ON EACH SIDE, hang the 1st st. onto the 2nd st. after Rows 162, 164, 166, 168, 170, 172, 174, 176, 178, 180, 182, 184, 186, 188, 190. ON CAM BOX SIDE, bind off 2 sts. after Rows 192, 193; 3 sts. after Rows 194, 195, 196, 197; 7 sts. after Row 198.

ON EACH SIDE, increase 1 st. after Rows 24, 34, 44, 54, 64, 74, 84, 94, 104, 114, 124, 134, 144, then knit to Row 152.

ROWS 0 to 24: Knit even.

Cast on 55 sts. and work stockinette st.

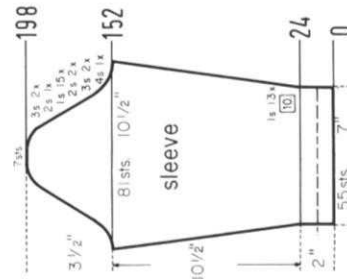

SIZE: 12/14. **MATERIAL:** 19½ oz. (11 balls) green KNITTING Crocus and a 20" zipper. **TENSION:** KNITTING 6 to 8. **GAUGE:** 14 sts, 2", 21 rows 2". **PATTERN:** Stockinette Stitch and a Cable Design on the front sections. (See Line Drawing for instructions). **EDGES:** K1, P1, Ribbing. **DECREASES:** After rows indicated, hang the 4th st. on the appropriate side onto the 3rd st., then move the end sts. inward to fill the empty needle. **INCREASES:** After rows indicated, move the 2 end sts. on the appropriate side 1 needle outward, then place the 3rd st. from the row below onto the empty needle. Bind off the ribbed bands on the crocheted method for ribbing. The finished length of the jumper is 36".

FINISHING: Block the sections to measurements given. Weave back sections together, 1 st. in from each edge. Beginning at the lower edge, weave front sections together for 12". Turn under 1 st. on remaining front edges and hem to wrong side. Sew pockets to jumper. Join front and back section at sides and shoulders, easing in the fullness at bustline of front sections. Turn under 18 rows on lower edge and hem to wrong side. Join short ends of armhole bands, then sew 1 edge of armhole band to inside and 1 edge to outside of armholes. Join neckbands at center back, then sew 1 edge of neckband to inside and 1 edge to outside of neckline. Sew in zipper.



The Cable Design reaches over the 34 sts marked on the diagram of the front section. After Row 130, hang the 1st and 2nd of these sts. onto the 3rd and 4th needle, then the 3rd and 4th sts. onto the 1st and 2nd needles. Cross the 15th and 16th sts. with the 17th and 18th sts., then the 29th and 30th sts. with the 31st and 32nd sts. in the same manner. Knit 4 rows. Now cross the 3rd and 4th sts. with the 5th and 6th sts., the 17th and 18th sts. with the 19th and 20th sts. then the 31st and 32nd sts. with the 33rd and 34th sts. Knit 4 rows. Repeat these 8 rows for Pattern.

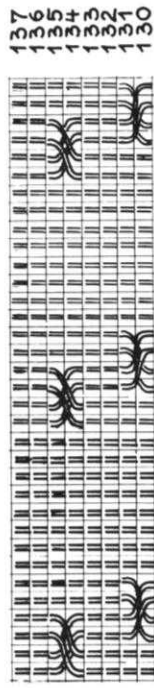

Cast on 111 sts. and work 22 rows K1, P1, Ribbing, then bind off all sts.



Cast on 173 sts. and work 22 rows K1, P1, Ribbing, then bind off all sts.



Cast on 48 sts., work stockinette st. and over the center 34 sts. work the Cable Design. Cross the sts. the first time after Row 4 and the last time after Row 52. After Row 58 transfer every other st. to the ribber and work 10 rows K1, P1, Ribbing. After Row 68 bind off all sts.

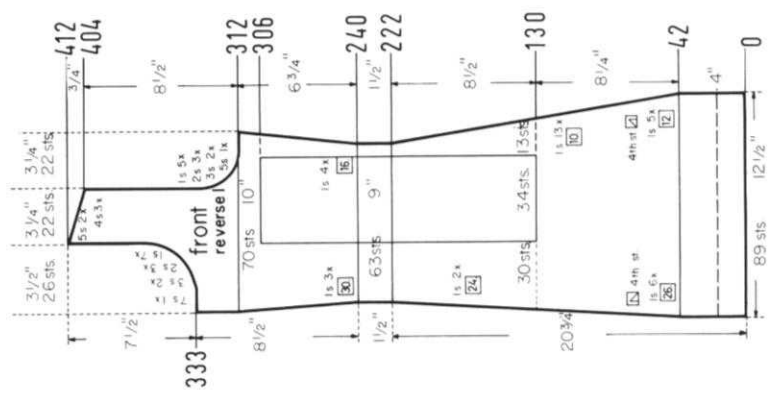

Work the second front section with reverse shapings, casting on from right to left. (Cam Box will be on the LEFT side at Row 0).

ON CAM BOX SIDE, bind off 5 sts. after Row 312 (EVEN ROWS = ARM-HOLE SHAPING); 3 sts. after Rows 314, 316; 2 sts. after Rows 318, 320, 322; 1 st. after Rows 324, 326, 328, 330, 332; 7 sts. after Row 333 (ODD ROWS = NECK SHAPING); 3 sts. after Rows 335, 337; 2 sts. after Rows 339, 341, 343; 1 st. after Rows 345, 347, 349, 351, 353, 355, 357. For SHOULDER, bind off 4 sts. after Rows 404, 406, 408; 5 sts. after Row 410, 412.

ON OPPOSITE SIDE OF CAM BOX increase 1 st. after Rows in (). ON CAM BOX SIDE, increase 1 st. after Rows 240, (240), 256, (270), 272, 288, (300). Cross the sts. the last time after Row 306, then knit to Row 312.

ON OPPOSITE SIDE OF CAM BOX decrease 1 st. after Rows in (). ON CAM BOX SIDE, decrease 1 st. after Rows 42, (42), 54, 66, (68), 78, 90, (94), 102, 112, (120), 122, (cross the sts. the first time after Row 130) 132, 142, (146), 152, 162, 172, (172), 182, 192, (198), 202, 212, 222, (222), then knit to Row 240.

ROWS 0 to 42: Knit even. Cast on 89 sts. and work stockinette st.

Work the second back section with reverse shapings, casting on from right to left. (Cam Box will be on the LEFT side at Row 0).

ON CAM BOX SIDE, bind off 8 sts. after Row 383 (ODD ROWS = NECK SHAPING); 3 sts. after Rows 385, 387, 389; 2 sts. after Rows 391, 393, 395; 4 sts. after Row 396 (EVEN ROWS = SHOULDER SHAPING); 1 st. after Row 397; 4 sts. after Row 398; 1 st. after Row 399; 4 sts. after Row 400; 1 st. after Row 401; 5 sts. after Rows 402, 404.

ON CAM BOX SIDE, bind off 5 sts. after Row 304 (EVEN ROWS = ARM-HOLE SHAPING); 3 sts. after Rows 306, 308; 2 sts. after Rows 310, 312, 314; 1 st. after Rows 316, 318, 320, 322, 324, then knit to Row 383.

ON OPPOSITE SIDE OF CAM BOX increase 1 st. after Rows in (). ON CAM BOX SIDE, increase 1 st. after Rows 240, (240), 256, (270), 272, 288, (300), then knit to Row 304.

ON OPPOSITE SIDE OF CAM BOX decrease 1 st. after Rows in (). ON CAM BOX SIDE, decrease 1 st. after Rows 42, (42), 54, 66, (68), 78, 90, (94), 102, 112, (120), 122, 132, 142, (146), 152, 162, 172, (172), 182, 192, (198), 202, 212, 222, (222), then knit to Row 240.

ROWS 0 to 42: Knit even. Cast on 89 sts. and work stockinette st.

MK 5241

SIZE: 8-9 (Chest 26"-27"). MATERIAL: 14 oz. (8 balls) red KNITTING Crocus and a 10" Zipper. TENSION: KNITTING 6 to 8. GAUGE: 14 sts. 2", 21 rows 2". PATTERN: Stockinette Stitch and a Cable Design on the front sections. (See Line Drawing for instructions). EDGES: K1, P1, Ribbing. Bind off the ribbed sections the crochet method for ribbing. DECREASES: After rows indicated, hang the 3rd st. ON EACH SIDE onto the 2nd st, then move the end sts. inward to fill the empty needle. The finished length of the jumper is 22 1/2".

FINISHING: Block the sections to measurements given. Weave the back sections together, 1 st. in from each edge. Beginning at the lower edges, weave the front sections together for 10", turn under 1 st. on the remainder of the front edges and hem to wrong side. Sew pockets to jumper, (see picture). Join front and back section at sides and shoulders. Turn under 2" on lower edge and hem to wrong side. Join short ends of armhole bands, then sew 1 edge of band to inside and 1 edge to outside of armholes. Sew neckband to neckline in the same manner. Sew in zipper.



2 1 4 3 2 2 1 2 1

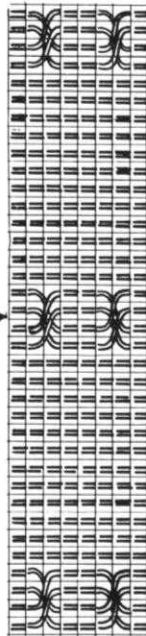

Work the second front section with reverse shapings, casting on from right to left. (Cam Box will be on the LEFT side at Row 0).

ON CAM BOX SIDE, bind off 4 sts. after Row 188 (EVEN ROWS = ARM-HOLE SHAPING); 3 sts. after Rows 194, 196; 1 st. after Rows 198, 200, 202; 4 sts. after Row 209 (ODD ROWS = NECK SHAPING); 3 sts. after Rows 211, 213; 2 sts. after Rows 215, 217; 1 st. after Rows 219, 221, 223, 225, 227, 229. For SHOULDER bind off 3 sts. after Rows 252, 254, 256; 4 sts. after Rows 258, 260.

ON EACH SIDE, decrease 1 st. after Rows 50, 64, 78, 92, 104, 116, 128, 140, 152, 164, 176, then knit to Row 188.

ROWS 0 to 50: Knit even. Cast on 76 sts., work stockinette st. and over the 36 sts. marked on the diagram work the Cable Design. Cross the sts. the first time after Row 2, then after every following 4th row.

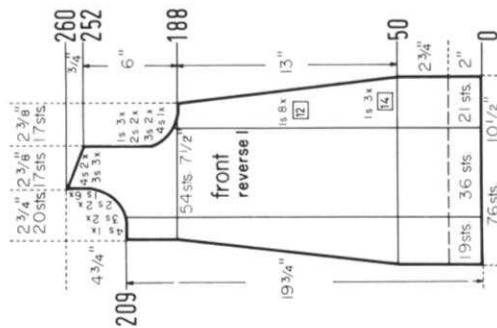

Work the second front section with reverse shapings, casting on from right to left. (Cam Box will be on the LEFT side at Row 0).

ON CAM BOX SIDE, bind off 4 sts. after Row 188 (EVEN ROWS = ARM-HOLE SHAPING); 3 sts. after Rows 194, 196; 1 st. after Rows 198, 200, 202; 4 sts. after Row 209 (ODD ROWS = NECK SHAPING); 3 sts. after Rows 211, 213; 2 sts. after Rows 215, 217; 1 st. after Rows 219, 221, 223, 225, 227, 229. For SHOULDER bind off 3 sts. after Rows 252, 254, 256; 4 sts. after Rows 258, 260.

ON EACH SIDE, decrease 1 st. after Rows 50, 64, 78, 92, 104, 116, 128, 140, 152, 164, 176, then knit to Row 188.

ROWS 0 to 50: Knit even. Cast on 76 sts., work stockinette st. and over the 36 sts. marked on the diagram work the Cable Design. Cross the sts. the first time after Row 2, then after every following 4th row.

Work the second back section with reverse shapings, casting on from right to left. (Cam Box will be on the LEFT side at Row 0).

ON CAM BOX SIDE, bind off 6 sts. after Row 243 (ODD ROWS = NECK SHAPING); 3 sts. after Rows 245, 247; 2 sts. after Rows 249, 251; 3 sts. after Row 252 (EVEN ROWS = SHOULDER SHAPING); 2 sts. after Row 253; 3 sts. after Row 254; 2 sts. after Row 255; 3 sts. after Row 256; 4 sts. after Rows 258, 260.

ON CAM BOX SIDE, bind off 4 sts. after Row 188 (EVEN ROWS = ARM-HOLE SHAPING); 3 sts. after Rows 190, 192; 2 sts. after Rows 194, 196; 1 st. after Rows 198, 200, 202, then knit to Row 243.

ON EACH SIDE, decrease 1 st. after Rows 50, 64, 78, 92, 104, 116, 128, 140, 152, 164, 176, then knit to Row 188.

ROWS 0 to 50: Knit even. Cast on 76 sts. and work stockinette st.

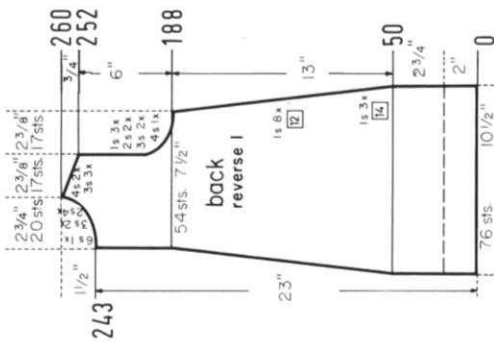

The Cable Design reaches over 36 sts. Using 2 double transfer tools, hang the 1st and 2nd sts. onto the 3rd and 4th needles, then hang the 3rd and 4th sts. onto the 1st and 2nd needles. Cross the 17th and the 18th sts. with the 19th and 20th sts., then the 33rd and 34th sts. with the 35th and 36th sts. in the same manner. Cross the sts. the first time after Row 2, then after every following 4th row.



Cast on 37 sts. and work 42 rows stockinette st., then transfer every other st. to the Ribber and work 10 rows K1, P1, Ribbing. After Row 52 bind off all sts.

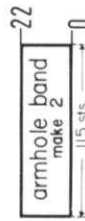

Cast on 115 sts. and work 22 rows K1, P1, Ribbing, then bind off all sts.



Cast on 161 sts. and work 22 rows K1, P1, Ribbing, then bind off all sts.

SIZE: 40/42. **MATERIAL:** 19 1/2 oz. (11 balls) yellow KNITTING Amore. **TENSION:** KNITTING 7 to 9. **GUAGE:** Pattern Stitch and Stockinette Stitch 14 sts, 2", 23 rows 2". **PATTERN:** Front and back section: Knit 7, Purl 1, Ribbing with crossed sts. (See Line Drawing for instructions). **Sleeves:** Stockinette Stitch. **Edges:** K1, P1, Ribbing. The knit side of all sections is the right side. **Sleeve Increases:** After rows indicated, move the 2 end sts. ON EACH SIDE 1 needle outward, then place the 3rd st. from the row below onto the empty needle. When putting needles into holding position, transfer the appropriate ribber sts. to the main machine first. After each Full-fashion decrease, move the end sts. inward to fill the empty needle.

FINISHING: Block all sections to measurements given. Join front and back section at sides. Sew sleeves together, then sew sleeves to front and back section. Join neckband sections at front and back, then sew band to neckline.

Cast on 125 sts. and work K1, P1, Ribbing. Knit Short Rows for the Shaping. ON OPPOSITE SIDE of CAM BOX put into holding position 2 needles after Rows 2, 4, 6, 8, 10, 12, 14, 16. After Row 18 bring all needles back into working position, then bind off all sts. Work the second neckband section with reverse shaping, casting on from right to left. (Cam Box will be on the LEFT side at Row 0).

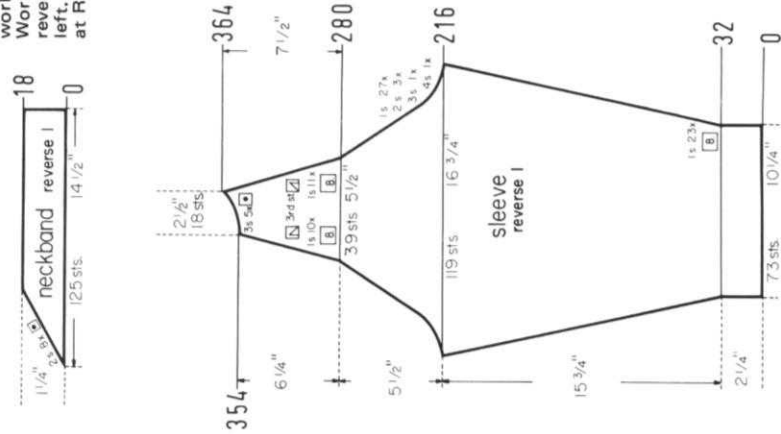

Work the second sleeve with reverse shaping, casting on from right to left. (Cam Box will be on the LEFT side at Row 0).

ON OPPOSITE SIDE of CAM BOX put into holding position 3 needles after Rows 354, 356, 358, 360, (360), 362. After Row 364 bring all needles back into working position, then bind off all 18 sts.

ON CAM BOX SIDE, bind off 4 sts. after Rows 216, 217; 3 sts. after Rows 218, 219; 2 sts. after Rows 220, 221, 222, 223, 224, 225. ON EACH SIDE, hang the 1st st. onto the 2nd st. after Rows 226, 228, 230, 232, 234, 236, 238, 240, 242, 244, 246, 248, 250, 252, 254, 256, 258, 260, 262, 264, 266, 268, 270, 272, 274, 276, 278. ON EACH SIDE, hang the 3rd st. onto the 2nd st. after Rows 280, 288, 296, 304, 312, 320, 328, 336, 344, 352, then decrease 1 more st. ON CAM BOX SIDE after Row in ().

ON EACH SIDE, increase 1 st. after Rows 32, 40, 48, 56, 64, 72, 80, 88, 96, 104, 112, 120, 128, 136, 144, 152, 160, 168, 176, 184, 192, 200, 208, then knit to Row 216.

ROWS 0 to 32: Knit even, then change to stockinette st. Cast on 73 sts. and work K1, P1, Ribbing.

Move the Cam Box to the left side, turn the Row Counter back to 198, set the needles up in PATTERN and complete the left half. Follow the instructions from *.

Work Short Rows for the SHOULDER. ON OPPOSITE SIDE of CAM BOX put into holding position 2 needles after Rows 277, (278), 279, 281, 283, (284), 285, 287; 3 needles after Rows 289, (290), 291, 293, 295, (296), 297, 299, 301, 303. (3 needles remain). After Row 305 bring all shoulder needles back into working position, then bind off all 39 sts.

* ON OPPOSITE SIDE of CAM BOX hang the 1st st. onto the 2nd st. after Rows in (). ON CAM BOX SIDE, bind off 5 sts. after Row 198; 3 sts. after Row 200; 2 sts. after Rows 202, (202), 204, 206; (206), 1 st. after Rows 208, 210, (210), 212. The ARMHOLE is now completed. Continue to decrease 1 st. ON NECK SIDE after Rows 214, 218, 222, 226, 230, 234, 238, 242, 246, 250, 254, 258, 262, 266, 272, then again after Rows in (). Knit to Row 277.

Work the front section the same as the back section to Row 198, then hang the center st. onto the neighboring needle, put the needles on the left side into holding position and complete the right half first.

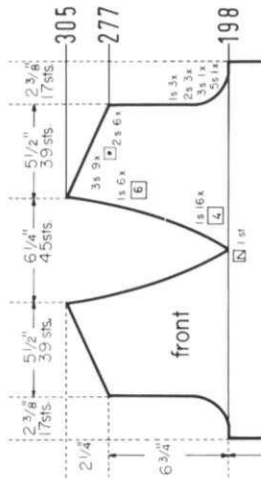

Work Short Rows for the SHOULDERS. ON OPPOSITE SIDE of CAM BOX put into holding position 2 needles after Rows 276, 277, 278, 279, 280, 281, 282, 283, 284, 285, 286, 287, 288, 289, 290, 291, 292, 293, 294, 295, 296, 297, 298, 299; 3 needles after Rows 300, 301, 302, 303, 304, 305, 306, 307, 308, 309, 310, 311, 312, 313. After Row 314 bring all needles back into working position, mark the center 33 sts. for NECK, then bind off all sts.

ON CAM BOX SIDE, bind off 5 sts. after Rows 198, 199; 3 sts. after Rows 200, 201; 2 sts. after Rows 202, 203, 204, 205, 206, 207; 1 st. after Rows 208, 209, 210, 211, 212, 213, then knit to Row 276.

ROWS 33 to 198: Knit even. ROWS 0 to 32: Knit even, then transfer the appropriate ribber sts. to the main machine and work the PATTERN STITCH. Cross the sts. the first time after Row 48, then after every following 16th row.

Cast on 157 sts. and work K1, P1, Ribbing.

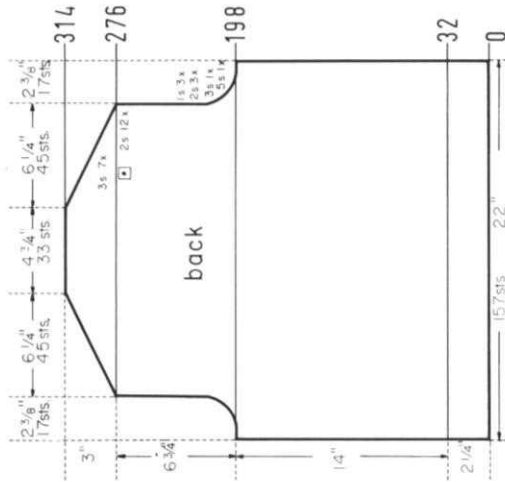

SIZE: 12/14. **MATERIAL:** 3 1/2 oz. (18 balls) green. **KNITTING:** Troyer-Tweed. **TENSION:** KNITTING 8 to 10. **GAUGE:** Stockinette Stitch 14 sts., 2", 19 rows 2". **PATTERN:** Stockinette Stitch with Cable Designs on the front and back sections of the jacket. **EDGES:** K1, P1, Ribbing. **Jacket and Sleeve INCREASES:** After rows indicated, move the 2 end sts. on the appropriate sides 1 needle outward, then place the 3rd st. from the row below onto the empty needle. **DECREASES:** Skirt: After rows indicated, hang the 4th st. ON EACH SIDE onto the 3rd st., then move the end sts. inward to fill the empty needle; Sleeves: After rows indicated, hang the 3rd st. on the appropriate sides onto the 2nd st., then move the end sts. inward to fill the empty needle. The finished length of the skirt is 22".

FINISHING: Block all sections to measurements given. **SKIRT:** Weave all 4 sections together, 1 st. in from each edge. Turn under 10 rows on upper edge and 16 rows on lower edge and hem to wrong side. Insert an elastic band into upper edge. **JACKET:** Join front and back sections at sides, easing in the fullness at bustline of front sections. Sew sleeves together and set in. Turn under 2" at front edges and hem to wrong side. Fold collar in half lengthwise and sew front edges. Sew 1 edge of collar to inside and 1 edge to outside of neckline, overlapping 2" on each front edge. Sew open edges together. Finish buttonholes, sew on buttons.

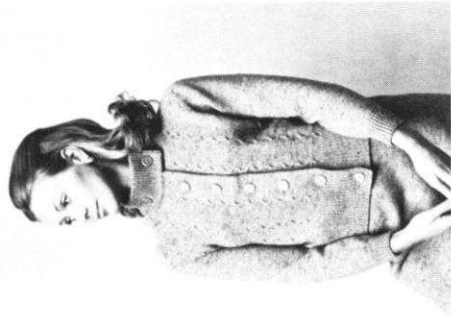

21 65 43 21 43 21

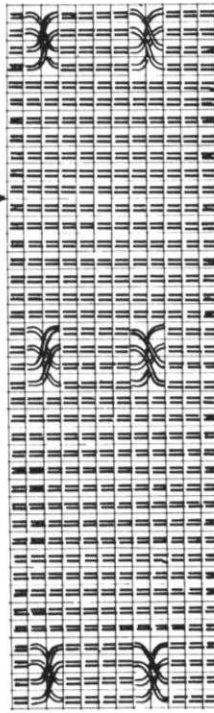

Cast on 197 sts. and work K1, P1, Ribbing. Make buttonholes after Rows 16 and 53 over the 7th-12th and 41st-46th sts. counting from the right side. After Row 68 bind off all sts. the crochet method for ribbing.

Work Short Rows for the SHOULDER SHAPING. ON OPPOSITE SIDE of CAM BOX put into holding position 3 needles after Rows 182, 183, 184, 185, 186, 187, 188, 189, 190, 191, 192, 193, 194, 195, 196, 197, 198, 199, 200, 201, 202, 203, 204, 205. After Row 206 bring all needles back into working position, mark the center 28 sts. for NECK, then bind off all sts.

ON CAM BOX SIDE, bind off 4 sts. after Rows 128, 129; 3 sts. after Rows 130, 131; 2 sts. after Rows 132, 133, 134, 135, 136, 137; 1 st. after Rows 138, 139, 140, 141, 142, 143, 144, 145, then knit to Row 182. ON EACH SIDE, increase 1 st. after Rows 52, 72, 92, 112, then knit to Row 128.

ROWS 0 to 52: Knit even, then change to stockinette st. and work the Cable Design. Use the Line Drawing to mark Cable Needles. Cross the sts. the first time after Row 56, then after every following 6th row.

Cast on 126 sts. and work K1, P1, Ribbing.

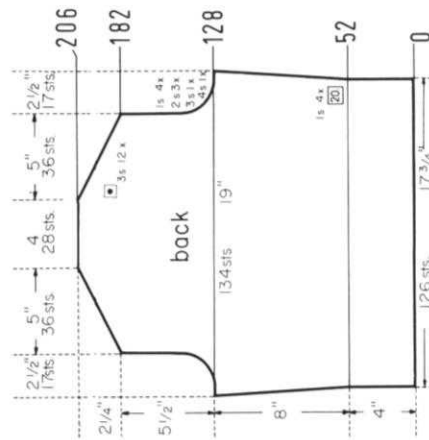

Work the left front section with reverse shaping, casting on from right to left. (Cam Box will be on the LEFT side at Row 0). Omit the buttonholes.

ON OPPOSITE SIDE of CAM BOX put 3 needles into holding position for SHOULDER after Rows in (). ON CAM BOX SIDE, bind off 30 sts. after Row 189; (189), 3 sts. after Row 191; (191), 2 sts. after Rows 193, (193), 195; (195), 1 st. after Rows 197, (197), 199; (199), 201; (201). The Neck Shaping is now completed. Continue to put 3 needles into holding position after Rows 203, 205; (4 sts. remain). After Row 207 bring all needles back into working position, then bind off all 31 sts.

Make 2 buttonholes after Rows in (). ON CAM BOX SIDE, bind off 4 sts. after Row 136; 3 sts. after Row 138; (139), 2 sts. after Rows 140, 142, 144; 1 st. after Rows 146, 148, 150, 152, (168), then knit to Row 189.

Make 2 buttonholes after Rows in (). ON CAM BOX SIDE, increase 1 st. after Rows 52, 72, (81), 92, (110), 112, then knit to Row 136.

ROWS 0 to 52: Make buttonholes after Row 13 over the 2nd-7th and 22nd-27th sts. counting from the left side. After Row 52 change to stockinette st., then make buttonholes over the same needles as before. Continue working the Cable Design, beginning with the 29th, 30th, 31st and 32nd sts. counting from the left side. (Right side for the left front section). Cross the sts. the first time after Row 56, then after every following 6th row.

Cast on 84 sts. and work K1, P1, Ribbing.

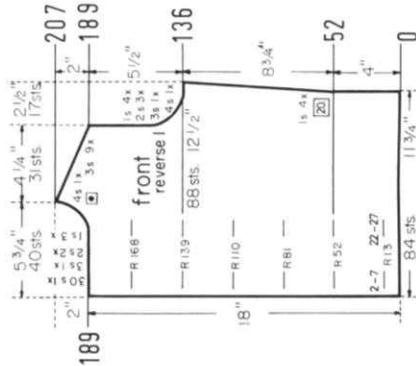

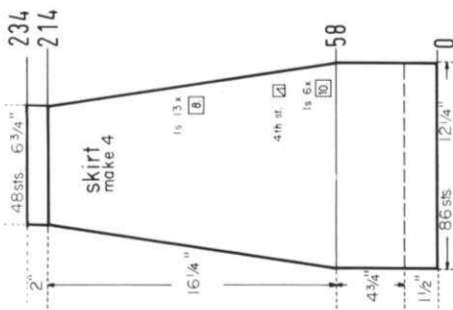

Work 3 more sections the same.

ON EACH SIDE, decrease 1 st. after Rows 58, 68, 78, 88, 98, 108, 118, 126, 134, 142, 150, 158, 166, 174, 182, 190, 198, 206, 214, then knit to Row 234 and bind off the remaining 48 sts.

ROWS 0 to 58: Knit even.

Cast on 86 sts. and work stockinette st.

Work the second sleeve with reverse shaping, casting on from right to left. (Cam Box will be on the LEFT side at Row 0).

ON CAM BOX SIDE, bind off 4 sts. after Rows 166, 167; 3 sts. after Rows 168, 169, 170, 171; 2 sts. after Rows 172, 173, 174, 175, 176, 177. ON EACH SIDE, decrease 1 st. after Rows 178, 180, 182, 184, 186, 188, 190, 192, 194, 196, 198, 200, 202, 204, 206, 208, 210, 212, 214, 216, 222, 228, 234, 240, 246, 252, then decrease 1 st. ON CAM BOX SIDE after Row 258. Work Short Rows for the Shaping. ON OPPOSITE SIDE of CAM BOX put into holding position 5 needles after Row 260; 3 needles after Rows 262, 264, 266. After Row 268 bring all needles back into working position, then bind off all 16 sts.

ON EACH SIDE, increase 1 st. after Rows 32, 40, 48, 56, 64, 72, 80, 88, 96, 104, 112, 120, 128, 136, 142, 148, 154, 160, then knit to Row 166.

ROWS 0 to 32: Knit even, then change to stockinette st.

Cast on 65 sts. and work K1, P1, Ribbing.

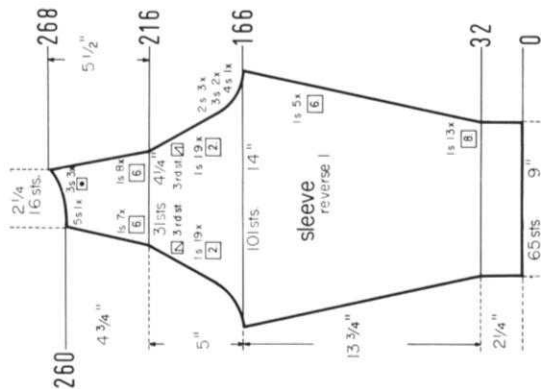

NEW VOLUME AVAILABLE NOW

A complete sixth volume of KNITTING MAGAZINES with a flexible, transparent plastic cover and specially bound so that it will stay open at any page, is available at the special price of \$6.95 (plus 85 cents mailing costs).

If purchased separately the magazines would cost a total of \$9.00.

The volume contains over 120 fully illustrated complete stylish patterns for all members of the family together with many valuable, practical knitting hints.

There is a very limited number of these volumes available and it will undoubtedly become a collectors item.

If you already have the entire set it will almost certainly be well thumbed and marked. Why not purchase a perfect mint condition volume for your bookshelf and ready reference at any time.

Place your order today and avoid disappointment. Send it to KNITTING MAGAZINE, 1128 Crenshaw Boulevard, Los Angeles, California 90019.



SIZE: 38/40. MATERIAL: 21 oz. (12 balls) brown KNIPTKING Lovely. TENSION: KNIPTKING 6 to 8. GAUGE: Stockinette Stitch 14 sts, 2", 20 rows 2". PATTERN: Stockinette Stitch and a Cable Design on the front section (see Line Drawing for instructions). EDGES and COLLAR: K1, P1, Ribbing. RAGLAN DECREASES: After rows indicated, hang the 3rd st. on the appropriate sides onto the 2nd st., then move the end sts. inward to fill the empty needle. SLEEVE INCREASES: After rows indicated, move the 2 end sts. ON EACH SIDE 1 needle outward, then place the 3rd st. from the row below onto the empty needle.

FINISHING: Block all sections to measurements given. Join front and back section at sides. Sew sleeves together, then weave sleeves to front and back section, 1 st. in from each edge. Join short ends of collar, then sew 1 edge of collar to inside and 1 edge to outside of neckline.



Move the Cam Box to the left side, turn the Row Counter back to 254 and complete the left half. Follow the instructions from *.

* Decrease 1 st. for RAGLAN ON CAM BOX SIDE after Row 254, then again after Rows in (). ON CAM BOX SIDE bind off 3 sts. after Row 255 (ODD ROWS = NECK SHAPING); (256), 2 sts. after Rows 257, (258), 259; (260), 261, (262), 263; (264), 1 st. after Rows 265, (266), 267, (268), 269, (270), 271, (272), 273, (274), 275. After Row 276 hang the remaining 3 sts. together, then bind off.

ON EACH SIDE, decrease 1 st. for RAGLAN after Rows 176, 178, 180, 182, 184, 186, 188, 190, 192, 194, 196, 198, 200, 202, 204, 206, 208, 210, 212, 214, 216, 218, 220, 222, 224, 226, 228, 230, 232, 234, 236, 238, 240, 242, 244, 246, 248, 250, 252. Now knit to Row 254, bind off the center 11 sts., put the needles on the left side into holding position and complete the right half first.

ROWS 41 to 176: Knit even.

ROWS 0 to 40: Knit even, then change to stockinette st. and work the Cable Design over the center 33 sts. Cross the sts. the first time after Row 46, then again after every following 10th row.

Cast on 151 sts. and work K1, P1, Ribbing.

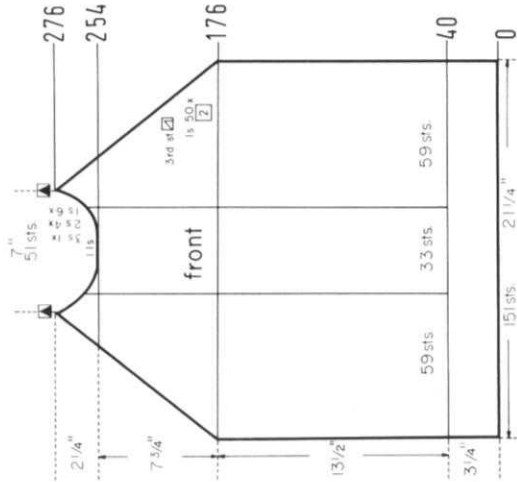

The Cable Design reaches over the center 33 needles. Counting from EACH SIDE, let the 1st, 2nd, 8th and 9th Cable Design sts. slide off the needles, leave the empty needles in working position. Using 2 treble transfer tools, hang the 10th, 11th and 12th sts. ON EACH SIDE onto the 13th, 14th and 15th needles, then hang the 13th, 14th and 15th sts. onto the 10th, 11th and 12th needles. Knit 10 rows, then repeat. After each 30 to 40 rows let the 1st, 2nd, 8th and 9th sts. ON EACH SIDE slide off the needles, let run down (the first time down to the Ribbing), then latch up into knit sts.

4
- 2
- 10
- 8
- 4
- 2
- 4
- 2
3
- 1
- 9
- 7
- 5
- 3
- 1
- 5
- 3
- 1

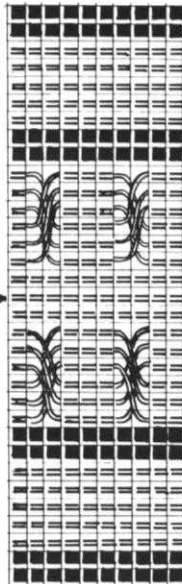

Cast on 171 sts. and work 60 rows K1, P1, Ribbing, then bind off all sts. the crochet method for ribbing.

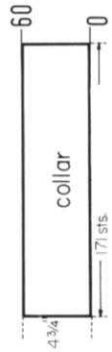

Work the second sleeve with reverse shaping.

ON EACH SIDE, decrease 1 st. for RAGLAN after Rows 196, 198, 200, 202, 204, 206, 208, 210, 212, 214, 216, 218, 220, 222, 224, 226, 228, 230, 232, 234, 236, 238, 240, 242, 244, 246, 248, 250, 252, 254, 256, 258, 260, 262, 264, 266, 268, 270, 272, 274, 276, 278, 280, 282, 284, 286, 288, 290, 292, 294, then knit to Row 296. Continue to decrease 1 st. for RAGLAN ON CAM BOX SIDE after Rows in (). ON OPPOSITE SIDE of CAM BOX put into holding position 3 needles after Rows 296, (296), 298, (298), 300, (300), 302, (302). After Row 304 bring all needles back into working position, then bind off the remaining 17 sts.

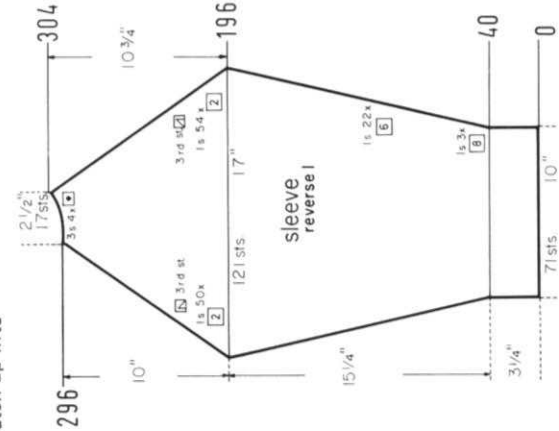

ON EACH SIDE, increase 1 st. after Rows 40, 48, 56, 64, 70, 76, 82, 88, 94, 100, 106, 112, 118, 124, 130, 136, 142, 148, 154, 160, 166, 172, 178, 184, 190, then knit to Row 196.

ROWS 0 to 40: Knit even, then change to stockinette st.

Cast on 71 sts. and work K1, P1, Ribbing.

ON EACH SIDE, decrease 1 st. for RAGLAN after Rows 176, 178, 180, 182, 184, 186, 188, 190, 192, 194, 196, 198, 200, 202, 204, 206, 208, 210, 212, 214, 216, 218, 220, 222, 224, 226, 228, 230, 232, 234, 236, 238, 240, 242, 244, 246, 248, 250, 252, 254, 256, 258, 260, 262, 264, 266, 268, 270, 272, 274, 276, 278, 280, 282. After Row 284 bind off the remaining 43 sts.

ROWS 41 to 176: Knit even.

ROWS 0 to 40: Knit even, then change to stockinette st.

Cast on 151 sts. and work K1, P1, Ribbing.

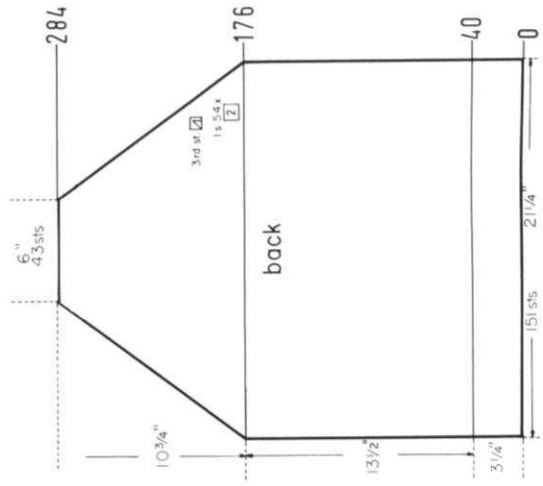

HP 3632

SIZE: 42/44. **MATERIAL:** 22 $\frac{3}{4}$ oz. (13 balls) gold KNITTING Crocus and a 23" Jacket Type Zipper. **TENSION:** KNITTING 6 to 8. **GAUGE:** Stockinette Stitch 16 sts., 2", 23 rows 2". **PATTERN:** Stockinette Stitch. **EDGES:** K1, P1, Ribbing. **INCREASES:** After rows indicated, move the 2 end sts. ON EACH SIDE 1 needle outward, then place the 3rd st. from the row below onto the empty needle. **DECREASES:** After rows indicated, hang the 3rd st. ON EACH SIDE onto the 2nd st., then move the end sts. inward to fill the empty needle.

FINISHING: Block all sections to measurements given. Join front and back sections at sides and shoulders. Sew sleeves together and set in. Fold ribbed portion of pockets to outside and sew in place with a button. Sew pockets to jacket. (See picture). Turn under 4 sts. on front edges and hem to wrong side. Fold collar in half lengthwise and close short ends. Sew cast-on edge of collar to inside and bound-off edge to outside of neckline. Sew zipper to front edges.



ON EACH SIDE, increase 1 st. after Rows 10, 12, 14, 16, 18, 20, 22, 24, 26, 28, 30, 32, 34, 36, 38, 40, 42, 44, 46, 48, 50. ON EACH SIDE, decrease 1 st. after Rows 54, 56, 58, 60, 62, 64, 66, 68, 70, 72, 74, 76, 78, 80, 82, 84, 86, 88, 90, 92, 94, then knit to Row 96 and bind off all 141 sts.

ROWS 0 to 8: ON OPPOSITE SIDE of CAM BOX put into holding position 45 needles after Rows 0 and 1. ON OPPOSITE SIDE of CAM BOX bring back into working position 15 needles after Rows 2, 3, 4, 5, 6, 7. All needles are back in working position after Row 8.

Cast on 141 sts., work stockinette st. and Short Rows.

Work the left front section with reverse shapings, casting on from right to left. (Cam Box will be on the LEFT side at Row 0).

ON CAM BOX SIDE, bind off 12 sts. after Row 289 (ODD ROWS = NECK SHAPING); 4 sts. after Row 291; 3 sts. after Rows 293, 295; 2 sts. after Rows 297, 299; 1 st. after Rows 301, 303, 305, 307, 309. For SHOULDER, bind off 4 sts. after Rows 316, 318, 320, 322; 5 sts. after Rows 324, 326, 328, 330, 332, 334.

ON CAM BOX SIDE, bind off 4 sts. after Row 210; 3 sts. after Rows 212, 214, 216; 2 sts. after Rows 218, 220; 1 st. after Rows 222, 224, 226, 228, then knit to Row 289.

ROWS 45 to 210: Knit even. ROWS 0 to 44: Knit even, then change to stockinette st. Cast on 98 sts. and work K1, P1, Ribbing.

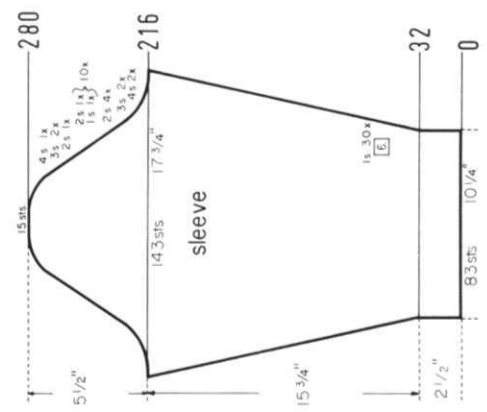
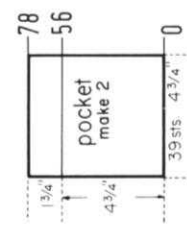
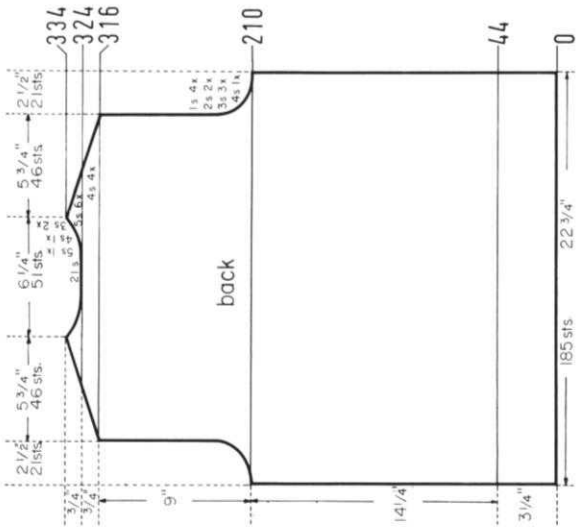

Cast on 39 sts. and work 56 rows stockinette st., then transfer every other st. to the ribber and work 22 rows K1, P1, Ribbing. After Row 78 bind off all sts. the crochet method for ribbing.

ON CAM BOX SIDE, bind off 4 sts. after Rows 216, 217, 218, 291; 3 sts. after Rows 220, 221, 222, 223; 2 sts. after Rows 224, 225, 226, 227, 228, 229, 230, 231; 1 st. after Rows 232, 233; 2 sts. after Rows 234, 235; 1 st. after Rows 236, 237; 2 sts. after Rows 238, 239; 1 st. after Rows 240, 241; 2 sts. after Rows 242, 243; 1 st. after Rows 244, 245; 2 sts. after Rows 246, 247; 1 st. after Rows 248, 249; 2 sts. after Rows 250, 251; 1 st. after Rows 252, 253; 2 sts. after Rows 254, 255; 1 st. after Rows 256, 257; 2 sts. after Rows 258, 259; 1 st. after Rows 260, 261; 2 sts. after Rows 262, 263; 1 st. after Rows 264, 265; 2 sts. after Rows 266, 267; 1 st. after Rows 268, 269; 2 sts. after Rows 270, 271, 272, 273; 3 sts. after Rows 274, 275, 276, 277; 4 sts. after Rows 278, 279; 15 sts. after Row 280.

ON EACH SIDE, increase 1 st. after Rows 32, 38, 44, 50, 56, 62, 68, 74, 80, 86, 92, 98, 104, 110, 116, 122, 128, 134, 140, 146, 152, 158, 164, 170, 176, 182, 188, 194, 200, 206, then knit to Row 216.

ROWS 0 to 32: Knit even, then change to stockinette st. Cast on 83 sts. and work K1, P1, Ribbing.

Move the Cam Box to the left side, turn the Row Counter back to 324 and complete the left half. Follow the instructions from *.

* ON CAM BOX SIDE, bind off 5 sts. after Rows 324 (EVEN ROWS = SHOULDER SHAPING), 325 (ODD ROWS = NECK SHAPING), 326; 4 sts. after Row 327; 5 sts. after Row 328; 3 sts. after Row 329; 5 sts. after Row 330; 3 sts. after Row 331; 5 sts. after Rows 332, 334.

ON CAM BOX SIDE, bind off 4 sts. after Rows 316, 317, 318, 319, 320, 321, 322, 323. After Row 324 bind off the center 21 sts., put the needles on the left side into holding position and complete the right half first.

ON CAM BOX SIDE, bind off 4 sts. after Rows 210, 211; 3 sts. after Rows 212, 213, 214, 215, 216, 217; 2 sts. after Rows 218, 219, 220, 221; 1 st. after Rows 222, 223, 224, 225, 226, 227, 228, 229, then knit to Row 316. ROWS 45 to 210: Knit even. ROWS 0 to 44: Knit even, then change to stockinette st. Cast on 185 sts. and work K1, P1, Ribbing.

SIZE: 14/16. **MATERIAL:** Jacket 15 1/2 oz. (9 balls) yellow; Shell 5 1/2 oz. (3 balls) yellow = Color A, 3 1/2 oz. (2 balls) olive = Color B and 3 1/2 oz. (2 balls) rust = Color C **KNITTING** Subita Dralon 3 ply. **TENSION:** KNITTING 5 to 7. **GAUGE:** Stockinette Stitch 15 sts. 2", 22 rows 2", **PATTERN:** **JACKET:** Stockinette Stitch; **SHELL:** Stockinette Stitch with repeated color stripes as marked in the diagram of the back section. **EDGES:** K1, P1, Ribbing. Bind off all ribbed bands the crochet method for ribbing. **SLEEVE INCREASES:** After rows indicated, move the 2 end sts. ON EACH SIDE 1 needle outward, then place the 3rd st. from the row below onto the empty needle.

FINISHING: Block all sections to measurements given. **JACKET:** Join front and back sections at sides and shoulders. Sew sleeves together and set in. Turn under 12 sts. on the front edges and hem to wrong side. Sew neckband to neckline, leaving a small opening on the right side for a buttonhole. Finish buttonholes, sew on buttons. **SHELL:** Join front and back section at sides and shoulders. Sew neckband to neckline. Work 1 row of single crochet around back opening. Make 3 loops on one side and sew 3 buttons to other side of opening. Join short ends of armhole bands, then sew bands to armholes.



Move the Cam Box to the left side, turn the Row Counter back to 230 and complete the left half. Follow the instructions from *.

* ON CAM BOX SIDE, bind off 3 sts. after Rows 231, 233; 2 sts. after Rows 235, 237; 1 st. after Rows 239, 241, 243, 245, 247. For SHOULDER, bind off 3 sts. after Rows 252, 254; 4 sts. after Rows 256, 258, 260, 262, 264, 266.

ON CAM BOX SIDE, bind off 5 sts. after Rows 156, 157, 158, 159; 3 sts. after Rows 160, 161, 162, 163; 2 sts. after Rows 164, 165, 166, 167, 168, 169; 1 st. after Rows 170, 171, 172, 173, 174, 175, 176, 177, then knit to Row 230, bind off the center 12 sts, put the needles on the left side into holding position and complete the right half first.

Work Short Rows for the DARTS. ON OPPOSITE SIDE of CAM BOX put into holding position 6 needles after Rows 126, 127, 128, 129, 130, 131, 132, 133, 134, 135, 136, 137. ON OPPOSITE SIDE of CAM BOX bring all needles back into working position after Rows 138, 139, then knit to Row 156.

Work the front section the same as the back section to Row 126.

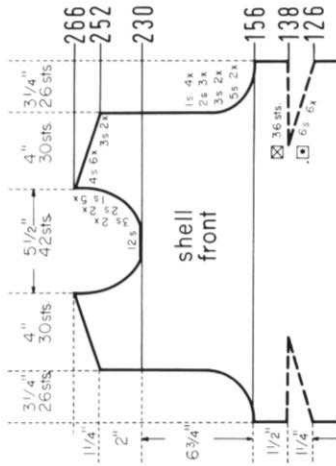

Move the Cam Box to the left side, turn the Row Counter back to 214 and complete the left half. Follow the instructions from *.

ON CAM BOX SIDE, bind off 3 sts. after Row 240 (EVEN ROWS = SHOULDER SHAPING); 7 sts. after Row 241 (ODD ROWS = NECK SHAPING); 3 sts. after Row 242; 4 sts. after Rows 243, 244, 245, 246; 3 sts. after Row 247; 4 sts. after Row 248; 3 sts. after Row 249; 4 sts. after Rows 250, 252, 254.

* Rows 215 to 240: Knit even. ON CAM BOX SIDE, bind off 5 sts. after Rows 144, 145, 146, 147; 3 sts. after Rows 148, 149, 150, 151; 2 sts. after Rows 152, 153, 154, 155, 156, 161, 162, 163, 164, 165, then knit to Row 214, put 51 needles on the left side into holding position and complete the right half first.

ROWS 17 to 144: Knit even. (For FRONT SECTION knit even to Row 126).

ROWS 0 to 16: Knit even, then change to stockinette st. and beginning with olive, work the repeated color stripes as marked in the diagram.

Cast on 154 sts. with yellow and work K1, P1, Ribbing.

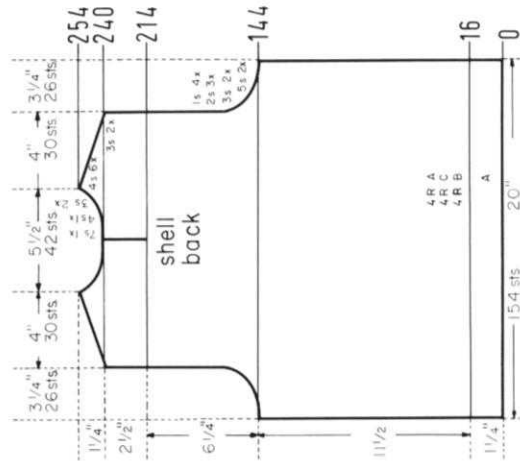

Cast on 188 sts. with yellow and work 14 rows K1, P1, Ribbing, then bind off all sts.

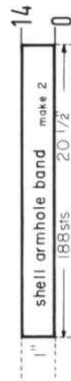

Cast on 133 sts. with yellow and work 14 rows K1, P1, Ribbing, then bind off all sts.



Work the left front section with reverse shapings, casting on from right to left. (Cam Box will be on the LEFT side at Row 0). Omit the buttonholes.

ON CAM BOX SIDE, bind off 24 sts. after Row 237 (ODD ROWS = NECK SHAPING); 3 sts. after Rows 239, 241; 2 sts. after Rows 243, 245, 247; 1 st. after Rows 249, 251, 253, 257, 261. For SHOULDER, bind off 3 sts. after Rows 262, 264; 4 sts. after Rows 266, 268, 270, 272, 274, 276, 278, 280.

ON CAM BOX SIDE, bind off 5 sts. after Row 170; 3 sts. after Rows 172, 174; 2 sts. after Rows 176, 178; 1 st. after Rows 180, 182, 184, 186. Make buttonholes after Row 193, then knit to Row 237.

Make buttonholes after Row in (). Work Short Rows for the DART. ON OPPOSITE SIDE of CAM BOX put into holding position 6 needles after Rows 141, 143, 145, 147, 149, (149), 151. After Row 153 bring all needles back into working position, then knit to Row 170.

ROWS 27 to 141: Make buttonholes after Rows 61, 105 over the same sts. as before.

ROWS 0 to 26: Make buttonholes after Row 13 over the 2nd-7th and 18th-23rd sts. counting from the left side. After Row 26 change to stockinette st.

Cast on 98 sts. and work K1, P1, Ribbing.

Cast on 151 sts. and work 14 rows K1, P1, Ribbing, then bind off all sts.

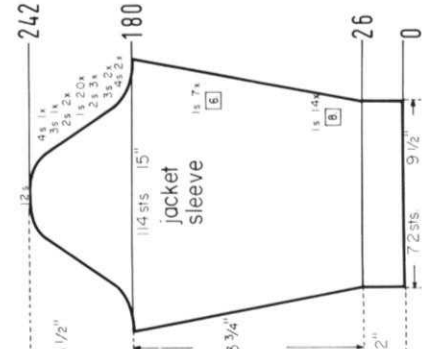
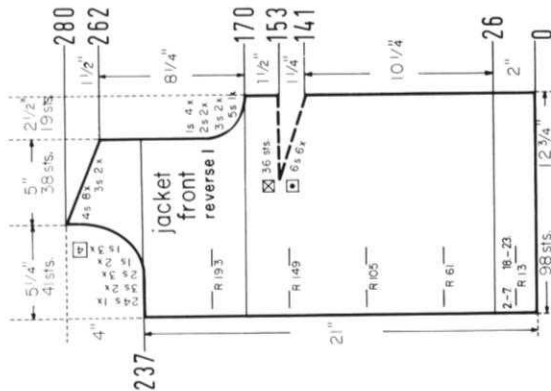

ON CAM BOX SIDE, bind off 4 sts. after Rows 180, 181, 182, 183; 3 sts. after Rows 184, 185, 186, 187; 2 sts. after Rows 188, 189, 190, 191, 192, 193. ON EACH SIDE, hang the 1st st. onto the 2nd st. after Rows 194, 196, 198, 200, 202, 204, 206, 208, 210, 212, 214, 216, 218, 220, 222, 224, 226, 228, 230, 232. ON CAM BOX SIDE bind off 2 sts. after Rows 234, 235, 236, 237; 3 sts. after Rows 238, 239; 4 sts. after Rows 240, 241; 12 sts. after Row 242.

ON EACH SIDE, increase 1 st. after Rows 26, 34, 42, 50, 58, 66, 74, 82, 90, 98, 106, 114, 122, 130, 138, 144, 150, 156, 162, 168, 174, then knit to Row 180.

ROWS 0 to 26: Knit even, then change to stockinette st.

Cast on 72 sts. and work K1, P1, Ribbing.

Move the Cam Box to the left side, turn the Row Counter back to 254 and complete the left half. Follow the instructions from *.

* ON CAM BOX SIDE, bind off 4 sts. after Row 254 (EVEN ROWS = SHOULDER SHAPING); 5 sts. after Row 255 (ODD ROWS = NECK SHAPING); 4 sts. after Row 256; 3 sts. after Row 257; 4 sts. after Row 258; 3 sts. after Row 259; 4 sts. after Row 260; 2 sts. after Row 261; 4 sts. after Row 262; 2 sts. after Row 263; 4 sts. after Rows 264, 266, 268.

ON CAM BOX SIDE, bind off 4 sts. after Rows 250, 251, 252, 253. After Row 254 bind off the center 15 sts., put the needles on the left side into holding position and complete the right half first.

ON CAM BOX SIDE, bind off 5 sts. after Rows 158, 159; 3 sts. after Rows 160, 161, 162, 163; 2 sts. after Rows 164, 165, 166, 167; 1 st. after Rows 168, 169, 170, 171, 172, 173, 174, 175, then knit to Row 250.

ROWS 27 to 158: Knit even.

ROWS 0 to 26: Knit even, then change to stockinette st.

Cast on 159 sts. and work K1, P1, Ribbing.

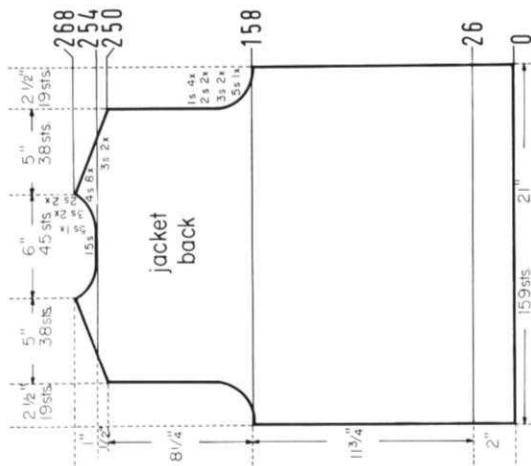

CANADIAN READERS

Please note that KNITTING dealers based in the U.S.A. are unable to sell machines and accessories to residents of Canada. They are also unable to sell parts and service. Would all Canadian readers please contact the following appointed KNITTING dealer.

KNITTING Sales and Service
2243 Danforth Ave.
Toronto 13, Ontario

Work the left front section with reverse shapings, casting on from right to left. (Cam Box will be on the LEFT side at Row 0).

ON OPPOSITE SIDE of CAM BOX decrease 1 st. for FRONT SHAPING after Rows in (). ON CAM BOX SIDE, bind off 5 sts. after Row 192; (192), 3 sts. after Rows 194, 196; (196), 2 sts. after Rows 198, 200, (200), 202; 1 st. after Row 204, (204), 206. The Armhole is now completed. Continue to decrease 1 st. on NECK SIDE after Rows 208, 214, 220, 226, 232, 238, 244, 250, 256, 262, 268, 274, 280, 286, then 1 more time after Row in (). For SHOULDER bind off 4 sts. after Row 288; 5 sts. after Rows 290, 292, (292), 294, 296, 298, 300, 302. Over the remaining 9 sts. work to Row 338, then put these sts. on a stitch holder.

Work Short Rows for the DART. ON OPPOSITE SIDE of CAM BOX put into holding position 7 needles after Rows 165, 167, 169, 171, 173. After Row 175 bring all needles back into working position and knit to Row 192.

ROWS 73 to 165: Knit even.

ROWS 37 to 72: Knit even, then continue with red.

ROWS 18 to 36: Knit even to Row 34, then form the hem and knit to Row 36, change to white and work the striped pattern as marked in the diagram.

ROWS 0 to 17: Knit even, then cast on 9 sts. ON CAM BOX SIDE with RED for the facing and continue working with 2 balls of yarn, the facing sts. always with red.

Cast on 77 sts. with blue and work stockinette st.

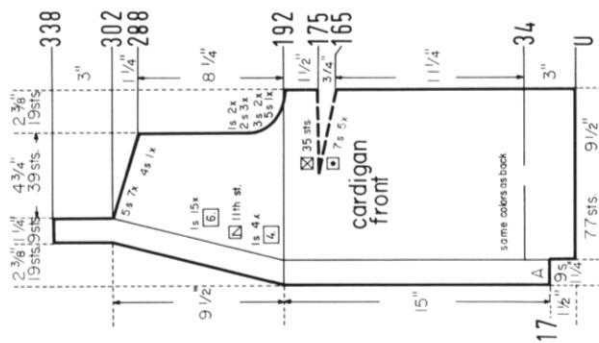

Move the Cam Box to the left side, turn the Row Counter back to 278 and complete the left half. Follow the instructions from *.

* ON CAM BOX SIDE, bind off 4 sts. after Row 278 (EVEN ROWS = SHOULDER SHAPING); 3 sts. after Row 279 (ODD ROWS = NECK SHAPING); 5 sts. after Row 280; 3 sts. after Row 281; 5 sts. after Row 282; 2 sts. after Row 283; 5 sts. after Row 284; 2 sts. after Row 285; 5 sts. after Row 286; 2 sts. after Row 287; 5 sts. after Row 288; 2 sts. after Row 289; 5 sts. after Row 290, 292.

ON CAM BOX SIDE, bind off 5 sts. after Rows 182, 183; 3 sts. after Rows 184, 185, 186, 187; 2 sts. after Rows 188, 189, 190, 191, 192, 193; 1 st. after Rows 194, 195, 196, 197; then knit to Row 278, bind off the center 16 sts., put the needles on the left side into holding position and complete the right half first.

ROWS 73 to 182: Knit even.

ROWS 37 to 72: Knit even, then continue with red.

ROWS 0 to 36: Knit even to Row 34, then form the hem and knit to Row 36, change to white and work the striped pattern as marked in the diagram.

Cast on 160 sts. with blue and work stockinette st.

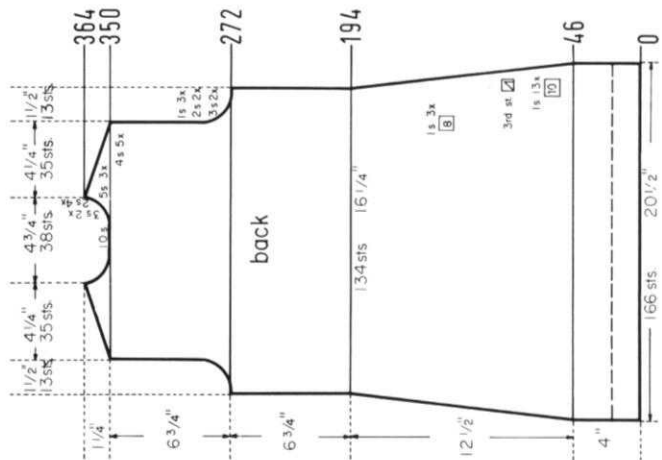
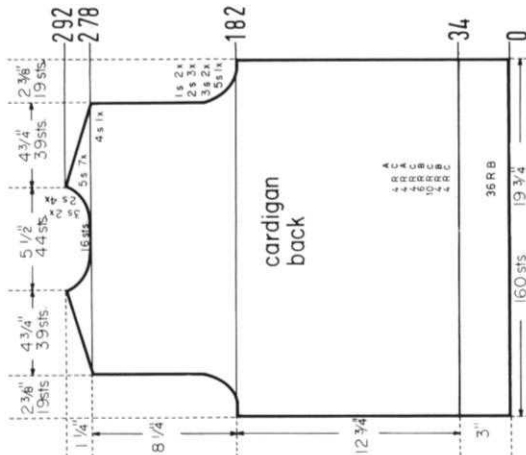

Move the Cam Box to the left side, turn the Row Counter back to 350 and complete the left half. Follow the instructions from *.

* ON CAM BOX SIDE bind off 4 sts. after Row 350 (EVEN ROWS = SHOULDER SHAPING); 3 sts. after Row 351 (ODD ROWS = NECK SHAPING); 4 sts. after Row 352; 3 sts. after Rows 353; 4 sts. after Row 354; 2 sts. after Row 355; 4 sts. after Row 356; 2 sts. after Row 357; 4 sts. after Row 358; 2 sts. after Row 359; 5 sts. after Row 360; 2 sts. after Row 361; 5 sts. after Rows 362, 364.

ON CAM BOX SIDE, bind off 3 sts. after Rows 272, 273, 274, 275; 2 sts. after Rows 276, 277, 278, 279; 1 st. after Rows 280, 281, 282, 283, 284, 285. Now knit to Row 350, then bind off the center 10 sts., put the needles on the left side into holding position and complete the right half first.

ON EACH SIDE, decrease 1 st. after Rows 46, 56, 66, 76, 86, 96, 106, 116, 126, 136, 146, 156, 166, 176, 184, 192, then knit to Row 272. (For FRONT SECTION knit to Row 194).

ROWS 0 to 46: Knit even.

Cast on 166 sts. and work stockinette st.

MK 5264

SIZE: 12-13 (Chest 30"-31"). MATERIAL: 14 oz. (8 balls) white, 1 1/2 oz. (1 ball) red and 1 1/2 oz. (1 ball) blue KNIITING Crocus and a 12" zipper. TENSION: KNIITING 5 to 7. GAUGE: Stockinette Stitch 16 sts. 2", 23 rows 2". PATTERN: Stockinette Stitch. Sleeve EDGES, COLLAR and BELT: K1, P1, Ribbing. DECREASES: After rows indicated, hang the 3rd st. ON EACH SIDE onto the 2nd st., then move the end sts. inward to fill the empty needle. INCREASES: After rows indicated, move the 2 end sts. ON EACH SIDE 1 needle outward, then place the 3rd st. from the row below onto the empty needle. When knitting short rows for the collar shaping, transfer the appropriate ribber sts. to the main machine first.

FINISHING: Block all sections to measurements given. Join front and back section at sides and shoulders. Sew sleeves together and set in. Work 1 row of slip stitch crochet around front opening. Sew collar to neckline, then sew zipper to front opening. Join belt sections at center back, then sew belt backing to wrong side and attach a buckle.



ON CAM BOX SIDE, bind off 3 sts. after Rows 36, 37, 38, 39, 40, 41; 2 sts. after Rows 42, 43, 44, 45. ON EACH SIDE, hang the 1st st. onto the 2nd st. after Rows 46, 48, 50, 52, 54, 56, 58, 60, 62, 64, 66, 68, 70, 72, 74, 76, 78, 80, 82. ON CAM BOX SIDE, bind off 2 sts. after Rows 84, 85, 86, 87; 3 sts. after Rows 88, 89, 90, 91; 9 sts. after Row 92.

ON EACH SIDE, increase 1 st. after Rows 12, 16, 20, 24, 28, then knit to Row 36.

ROWS 0 to 12: Work 4 rows red, 4 rows white and 4 rows blue, then change to stockinette st. and continue working with white.

Cast on 83 sts. with red and work K1, P1, Ribbing.

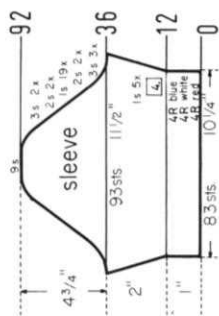

Cast on 195 sts. with red and work K1, P1, Ribbing, 4 rows red, 4 rows white and 4 rows blue, then continue with white. After Row 36 work Short Rows for the Shaping. ON OPPOSITE SIDE of CAM BOX put into holding position 16 needles after Rows 36, 37, 38, 39, 40, 41, 42, 43. After Row 44 bring all needles back into working position, then bind off all sts. the crochet method for ribbing.

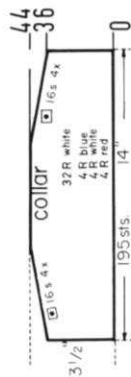

Cast on 138 sts. with red and work K1, P1, Ribbing, 4 rows red, 8 rows white and 4 rows blue. After Row 16 bind off all sts. the crochet method for ribbing.



SIZE: 10-11 (Chest 28"-29"). **MATERIAL:** 12 1/2 oz. (7 balls) medium blue = Color A, small amounts of white = Color B, red = Color C, yellow = Color D and dark blue = Color F. **KNITTING** Subra Crepe 2 x 3. **TENSION:** KNITTING 5 to 7. **GAUGE:** 17 sts, 2", 24 rows 2". **PATTERN:** Stockinette Stitch and color stripes at the yoke of the front and back section as marked on the diagram of the back section. **EDGES:** K1, P1, Ribbing. **DECREASES:** After rows indicated, hang the 3rd st. ON EACH SIDE onto the 2nd st., then move the end sts. inward to fill the empty needle. **INCREASES:** After rows indicated, move the 2 end sts. ON EACH SIDE 1 needle outward, then place the 3rd st. from the row below onto the empty needle. The finished length of the dress is 27".

FINISHING: Block all sections to measurements given. Join front and back section at sides and shoulders. Sew sleeves together and set in. Turn under 20 rows on lower edge and hem to wrong side. Sew neckband to neckline. Work 1 row of single crochet around back opening. Make 4 loops on one side and sew 4 buttons to other side of back opening. Fasten front tab to yoke with buttons. (See picture).

Move the Cam Box to the left side, turn the Row Counter back to 194 and complete the left half. Follow the instructions from *.

ON CAM BOX SIDE, bind off 5 sts. after Row 337 (ODD ROWS = NECK SHAPING); 3 sts. after Rows 339, 341; 2 sts. after Rows 343, 345; 1 st. after Rows 347, 349; 4 sts. after Row 350 (EVEN ROWS = SHOULDER SHAPING); 1 st. after Row 351; 4 sts. after Row 352; 1 st. after Row 353; 4 sts. after Rows 354, 356, 358; 5 sts. after Rows 360, 362, 364.

ON CAM BOX SIDE, bind off 3 sts. after Rows 272, 274; 2 sts. after Rows 276, 278; 1 st. after Rows 280, 282, 284, then knit to Row 337.

* ROWS 195 to 272: Knit even.

Work the front section the same as the back section to Row 194, then put 67 needles on the left side into holding position and complete the right half first.

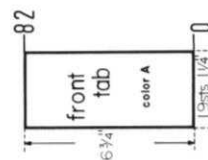
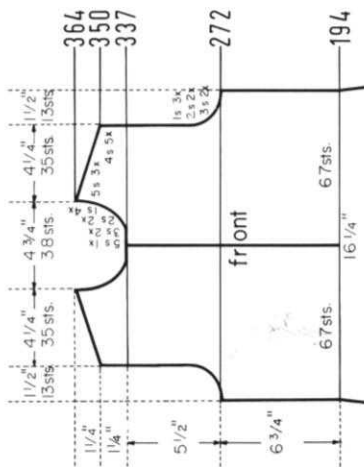

Cast on 19 sts. with medium blue (Color A) and work 82 rows K1, P1, Ribbing, then bind off all sts.

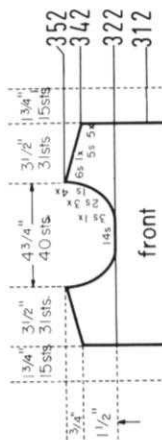

MK 5265

Move the Cam box to the left side, turn the Row Counter back to 312 and complete the left half. Follow the instructions from *.

ON CAM BOX SIDE, bind off 5 sts. after Row 342 (EVEN ROWS = SHOULDER SHAPING); 10 sts. after Row 343 (ODD ROWS = NECK SHAPING); 5 sts. after Row 344; 4 sts. after Row 345; 5 sts. after Row 346; 3 sts. after Row 347; 5 sts. after Row 348; 3 sts. after Row 349; 5 sts. after Row 350; 6 sts. after Row 352.

* Rows 313 to 342: Knit even.

ON CAM BOX SIDE, bind off 4 sts. after Rows 264, 265; 3 sts. after Rows 266, 267; 2 sts. after Rows 268, 269, 270, 271, 272, 273; 1 st. after Rows 274, 275, 276, 277, then knit to Row 312, put 51 needles on the left side into holding position and complete the right half first. (Do NOT divide the sts. on the Front Section).

ON EACH SIDE, decrease 1 st. after Rows 48, 58, 68, 78, 88, 98, 108, 118, 126, 134, 142, 150, 158, 166, 174, 182, then knit to Row 264, change to yellow and work the striped pattern as marked in the diagram.

ROWS 0 to 48: Knit even.

Cast on 164 sts. with medium blue (Color A) and work stockinette st.

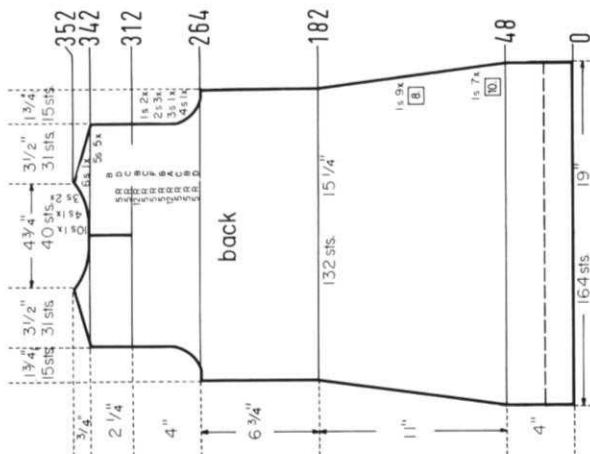

KG 1910

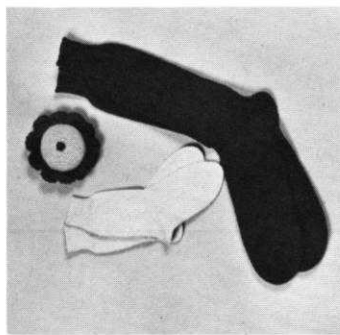

MATERIAL: KNITKING Fortissima (amounts as shown at right for each size). The amount of yarn specified is for sock length and you should order extra yarn for longer socks. The amount of yarn specified for Baby socks will make at least two pair. **TENSION:** 4 to 6. **GAUGE:** 18 sts., 24 rows to 2".

FINISHING: Weave the open heel sts. to open leg sts. Remove waste yarn. Weave back of leg seam and sides of instep. You may make these socks shorter or longer by knitting more or less rows for leg length. Increase the number of sts. for larger leg by casting on any number of sts. divisible by 4 plus 1 st. If knitting them very long, be sure to cast on sufficient sts. and space decreases along the leg edges for proper shaping so that you end up with a number of stitches divisible by 4 at the beginning of the instep. If you wish to seam the sock along the instep as you knit the sole, pick up edge stitches on each side of instep on every other row as you knit (see Practical Knitting Hints Book, page 24). You may also use a stripe pattern, cable design or a Norwegian pattern for the leg and instep sections.

ON CAM BOX SIDE, bind off 4 sts. after Rows 40, 41; 3 sts. after Rows 42, 43; 2 sts. after Rows 44, 45, 46, 47, 48, 49, 50, 51. ON EACH SIDE, hang the 1st st. onto the 2nd st. after Rows 52, 54, 56, 58, 60, 62, 64, 66, 68, 70, 72, 74, 76, 78, 80, 82. ON CAM BOX SIDE, bind off 2 sts. after Rows 84, 85, 86, 87; 3 sts. after Rows 88, 89, 90, 91; 11 sts. after Row 92.

ON EACH SIDE, increase 1 st. after Rows 10, 16, 22, 28, 34, then knit to Row 40.

ROWS 0 to 10: Knit even, then change to stockinette st.

Cast on 83 sts. with medium blue (Color A) and work K1, P1, Ribbing.

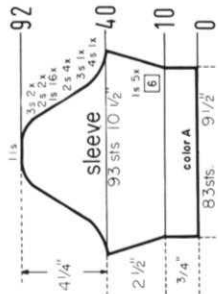

Cast on 131 sts. with medium blue (Color A) and work 14 rows K1, P1, Ribbing, then bind off all sts. the croch method for ribbing.

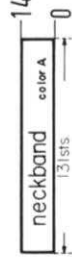

SIZE	INFANT			CHILDREN			WOMEN			MEN		
	3-4	5-6		7-8	9-10		8	9	10	Sm.	Med.	Large
MATERIAL: Balls (1 1/2 oz.)	1	1		1	2		2	2	2	2	2	2
CUFF: Cast on sts.	41	45		49	53		57	57	61	65	69	73
Rib K1, P1 rows	12	14		18	24		24	24	30	18 for slack	36 for regulation	
Transfer rib sts. to main machine and decrease 1 st. on one side only.												
LEG: Knit rows	20	24		48	50		72	72	72	72 for slack	120 for regulation	
DIVIDE STS: On EACH SIDE remove onto a stitch holder.												
sts.	10	11		12	13		14	14	15	16	17	18
INSTEP: On remaining center sts. Knit even rows	20	22		24	26		28	28	30	32	34	36
rows	18	22		30	42		72	78	84	84	96	108
TURN TOE: Short Rows. Put 1 needle opposite Cam Box into holding position beginning each row until sts. remain in work.												
sts.	4	4		6	6		6	6	6	8	10	10
Put back 1 needle opposite Cam Box beginning each row until all sts. are in work.												
SOLE: Knit even rows	18	22		30	42		72	78	84	84	96	108
TURN HEEL: Short rows. Put 1 needle opposite Cam Box into working position beginning each row until sts. remain in work.												
sts.	4	4		6	6		6	6	6	8	10	10
Put back 1 needle opposite Cam Box beginning each row until all sts. are in work.												

MATERIAL: 5½ oz. (3 balls) blue and 1½ oz. (1 ball) red **KNITTING** Leacril (makes 2 pair).
TENSION: **KNITTING** 8 to 10. **GAUGE:** 10 sts, 2", 13 rows 2". **PATTERN:** Stockinette Stitch using every other needle.

FINISHING: Weave the 18 sts. from upper and the 16 sts. from lower section together, doubling up the first 2 sts. ON EACH SIDE on the upper section. Weave the sts. together from the right side to obtain a ridge down the inside center, matching the marked row. Trim with buttons or embroidery for eyes and nose. Make yarn hair or a pom-pom. If you wish you can make ears for any animal shape you like.

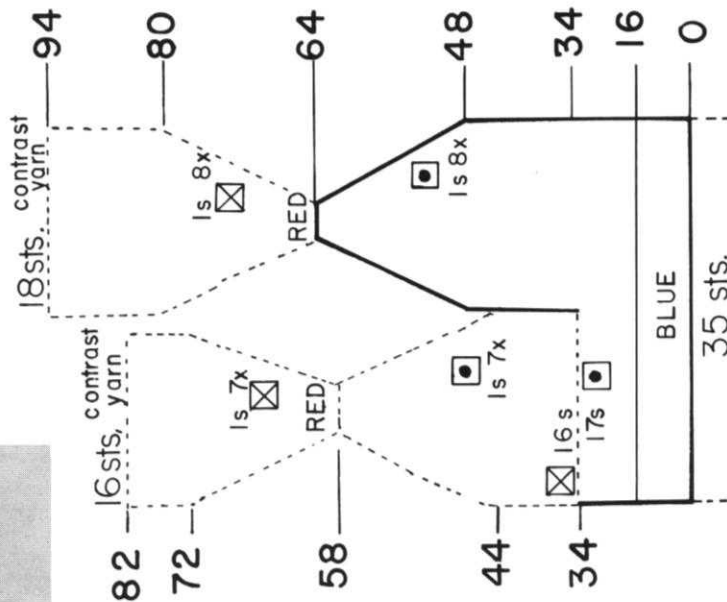
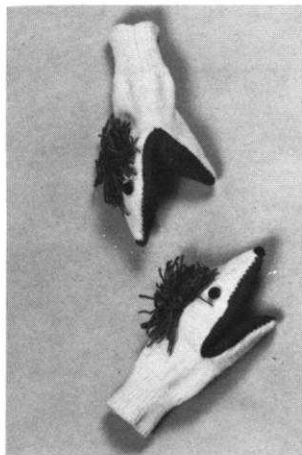

Work the second mitten in reverse, casting on from right to left. (Cam Box will be on the LEFT side at Row 0).

ROWS 73 to 82: Knit even over 16 needles, then knit several rows with contrast waste yarn and remove work from machine.

ON OPPOSITE SIDE of CAM BOX put into holding position 1 needle after Rows 44, 45, 46, 47, 48, 49, 50, 51, 52, 53, 54, 55, 56, 57. (2 needles remain in working position.) After Row 58 change to red and lower tension 1 number. **ON OPPOSITE SIDE of CAM BOX** bring back into working position 1 needle after Rows 58, 59, 60, 61, 62, 63, 64, 65, 66, 67, 68, 69, 70, 71, then knit to Row 72.

ROWS 35 to 44: Knit even, then knit short rows.

ON OPPOSITE SIDE of CAM BOX, bring the 17 needles back into working position, decrease 1 st. and work stockinette st. with the original tension over 16 needles for the lower part of the mitten.

ROWS 81 to 94: Knit even over 18 needles, then knit several rows with contrast waste yarn and remove these sts. from the machine. Turn the Row Counter back to 34.

ON OPPOSITE SIDE of CAM BOX bring back into working position 1 needle after Rows 64, 65, 66, 67, 68, 69, 70, 71, 72, 73, 74, 75, 76, 77, 78, 79, then knit to Row 80.

ON OPPOSITE SIDE of CAM BOX put into holding position 1 needle after Rows 48, 49, 50, 51, 52, 53, 54, 55, 56, 57, 58, 59, 60, 61, 62, 63, then knit to Row 64. (2 needles remain in working position) change to red and lower tension 1 number.

ROWS 35 to 48: Knit even, then work short rows.

EACH SIDE with a contrast yarn, then mark needles ON OPPOSITE SIDE of CAM BOX in holding position and complete the upper part of the mitten first. (18 sts.)

ROWS 0 to 16: Knit even, then change to stockinette st.

Cast on 35 sts. with blue (use every 4th needle on the main machine and every 2nd needle on the ribber) and work K1, P1, Ribbing.



KNITTING NEWS

September/October, 1970

OUR READERS WRITE

One of the most frequently asked questions we still receive from readers is "How can I weave stitches together that are held on contrast waste yarn?" We did have an article on this some time ago, but because very obviously a large number of subscribers did not see it, we are repeating it herewith.....

WEAVING OPEN STITCHES TOGETHER

There are many occasions when you will want to weave open stitches together such as on the heels and toes of socks, skirts, facings, etc... To obtain the needed open stitches for weaving, you must begin and end your knitting with contrast waste yarn.

Some people steam the open ends and then struggle to weave the stitches from the right side. We at KNITKING have what we think is a better way and we want you to try it...

Please follow the directions exactly from start to finish and this will be your practice piece. In order for you to see the stitches easily, make your sample piece using KNITKING Frigate or a similar weight yarn (4-ply worsted is O.K.) knitted over every other needle.

Cast on a total of 30 stitches with contrast waste yarn of same weight as main yarn. Use the Automatic Cast-on method (See Practical Knitting Hints Book - page 12). Knit 3 to 5 rows ending with Cam Box (or Slide) on the left side. Now knit 1 row with a Ravel Cord. A piece of rayon crochet cotton (not too fine) makes an excellent Ravel Cord. Change to main yarn and knit 49 rows (any odd number) ending with Cam Box on the LEFT side. Leave a length of yarn about 3 times as wide as the knitting on machine, then cut. Knit 8 rows with contrast yarn and remove work from machine.

Now you are ready to weave the stitches together. Thread a Tapestry needle or Ribber Transfer Needle with the long end of main yarn. NEVER use a pointed needle for weaving stitches together.

Take your sample of knitting and fold it in half with the KNIT side INSIDE and the PURL side OUTSIDE. The threaded needle should be on the RIGHT BACK HALF and the Ravel Cord on the FRONT HALF. Allow the edges knitted with the contrast yarn on both ends to roll toward the INSIDE (knit side) so that you are holding it in such a way as to see and match up the FIRST row of main knitting at each end.

Begin to weave... Pick up the threaded needle in your right hand and holding the knitting together in your left, go into the first stitch on the back section from the BACK. (Be careful here, as it is important that you go into the stitch made with the yarn end...pull the strand gently so you SEE it). Continuing with the needle coming toward you, go into the edge of front section.... this is not a stitch, but a loop with the Ravel Cord through it. Now go into the first stitch on

the front section from the FRONT to back (away from you) across to the back section (away from you) into the original first stitch on the back section. Bring the needle into the second stitch on the back section from the BACK (toward you) across and into the first stitch (that you worked before) on the front section. Go into the second stitch on the front section from the FRONT to back (away from you) into the second stitch (that you worked before) on the back section... into the next stitch on the back section from BACK to front (toward you) and into stitch (that you worked before) on the front section... etc., etc... Take note that you ALWAYS go into a stitch twice to complete it. ALWAYS pull up each stitch every time, just enough to match the main knitting... not too tight, nor too loose. If you will take a good look at your knitting, you will soon see that you are following the course of the Ravel Cord on one side and the contrast yarn on the other. When you come to the end, complete the weaving, being certain that you have gone into loop below where end of Ravel Cord is, then back to last stitch on the back section.

You are now ready to remove the contrast waste yarn. Turn your sample to the knit side out. When you knitted your sample piece, you ended with 8 rows of contrast waste yarn and this will rip out very easily - so just pull it out. The cast-on end holds the Ravel Cord- Release each end of the Ravel Cord by pulling it out of first stitch, then pull out the Ravel Cord and the waste yarn falls away. If it pulls hard, or if you have used a fine soft yarn when knitting a garment, you should really remove the Ravel Cord a few stitches at a time. If you have used rayon crochet cotton for a Ravel Cord (not a commercial cord) you can cut it every inch or so, then pull the pieces out and throw them away.

Now take a good look at your weaving.... pretty good eh?

Another very frequently asked question from KNITKING owners is in regard to Ribbing with a heavy (4-ply) worsted weight yarn. Here is the answer:

EASY CAST-ON for RIBBING with HEAVY YARN

Before Ribbing (knitting too) with heavy weight yarn that must be knitted over every other needle, wax your yarn with paraffin in the following manner:

While winding your yarn, hold the paraffin wax in your left hand and allow the yarn to run over it, controlling the yarn with very slight pressure from your thumb and, if the ball winds too tight, wind it a second time without using the wax.

Bring every other needle on the main machine into HOLDING position, making sure one of those needles is the "0" (center) needle followed by an uneven number of needles on each side of the "0". Cast on from left to right over these needles in back of the latches, then put all needles into working position (you may use your Needle Shifter to bring the needles into work). Set your tension at 8, 9 or 10, depending on the weight of

yarn and the tension you will use for knitting the body of garment. Knit 1 row to the left side (Row Counter will be at 1). Now fix your Ribber on to the Machine with the Ribber Cam Box on the LEFT SIDE. Transfer the center stitch - then every other stitch on each side - to the Ribber using alternate Ribber needles. Make sure the latches on the Ribber are open and that the stitches slide behind the latches. See that the white Strippers are in place, connect the Cam Boxes and begin Ribbing.

ALTERNATE CAST-ON WITH HEAVY YARN

If your yarn is rather stiff and the above Ribbing edge does not seem to have much elasticity, here is an alternate method to use which will give you a very elastic edge.

Fix your Ribber onto machine with BOTH Cam Boxes on the LEFT side. Bring the Ribber needle directly opposite the "0" needle on Main Machine into working position (all the way up) then bring every alternate needle of Ribber on each side into working position. Bring the 3rd then every 4th needle on either side of the Main Machine into working position. Remember that the first and last needle must always be a Main Machine needle. Cast on in the normal way for Ribbing... counter clockwise on the Main Machine needles and clockwise on the Ribber needles. The stitches should be in FRONT of the latches on the Main Machine and BEHIND the latches on the Ribber. Run the Cam Box of the Main Machine to the right side (this will put the Main Machine stitches behind the latches). Now hold the yarn under the hooks of the Ribber needles (right to left) and knit each Ribber stitch by hand, bringing the Ribber needles back into knitting position and making sure the latches are OPEN. Run the Main Machine Cam Box across to the LEFT side. See that the white Strippers are in place, connect the Cam Boxes, place yarn in Holder and Feed Finger, then proceed with Ribbing.

INSTRUCTIONS FOR KNITTING THE PINCUSHION that appears on page 13 of this issue.

MATERIAL: Small amounts of 2 colors KNITKING Sonika Dralon. 2 1/2" circle of Polyfoam at

least 1" thick (you may cut the circle from a kitchen sponge). TENSION: 6 to 8. GAUGE: 14 sts. 19 rows 2".

OPEN CAST-ON 24 sts. using contrast waste yarn. After knitting several rows, knit 1 row to the right side with a ravel cord, change to main color yarn and put counter at 0.

ROWS 1-8: Put 3 needles opposite Cam Box into holding position beginning next 2 rows and 2 needles beginning next 6 rows. (Short Rows)

ROWS 9-16: Put back into working position 2 needles opposite Cam Box beginning next 6 rows and 3 needles beginning next 2 rows.

ROWS 17-96: REPEAT ROWS 1-16 5 times more (6 sections) knit several rows with contrast waste yarn and remove work from machine.

PETAL EDGING: With second color, cast on 61 sts. OVER EVERY OTHER NEEDLE. Work with tension 10. Put the 1st, then every 6th needle into holding position and knit 10 rows (be sure to wrap the yarn around the end needle in holding position beginning every row).

ROW 11: Return all needles to working position and knit this one row slowly. Break yarn leaving a long end, then tie this end to the cast on end tightly against the stitches. Thread tapestry needle with long end of yarn, release stitches from under the sinkers and take each stitch off on strand of yarn.

FINISHING: Weave half the stitches together that are held on waste yarn, then stuff the foam circle into this half and weave the rest of the stitches held on waste yarn. Remove waste yarn. Pull up the Petals and pin to fit around cushion a little more than half way down from the top of cushion. With long strand of yarn, sew Petals to cushion, making sure to only go through the knitting (not the foam) and working from the underside, catch each open stitch of Petals. Make 3 French knots in center of top.

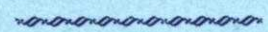

ARE YOU UNHAPPY WITH YOUR PRESENT KNITTING MACHINE ?

- DOES IT REFUSE TO KNIT FANCY DRESS YARNS?**
- DOES IT JAM UP WHEN YOU TRY TO KNIT LOOPED MOHAIR OR THICK AND THIN YARNS?**
- DOES IT DROP STITCHES ALL OVER THE PLACE?**
- ARE YOU CONTINUALLY HAVING TROUBLE WITH AWKWARD, CUMBERSOME WEIGHTS?**
- ARE YOU UNABLE TO MAKE A LARGE GARMENT WITH BULKY YARNS?**
- DO YOU HAVE TO SELECT PATTERN STITCHES MANUALLY?**
- DO YOU HAVE TO LATCH YOUR RIBBING BY HAND?**

IF YOU ARE HAVING ANY OF THESE PROBLEMS YOU SHOULD TRADE UP TO A NEW FANTASTIC PUSH BUTTON KNITKING WITH COORDINATED RIBBER AND ENJOY KNITTING WITH THE WORLDS FINEST, MOST VERSATILE AND MOST AUTOMATIC KNITTER.

YOU WILL BE SURPRISED AT OUR GENEROUS TRADE-IN ALLOWANCE AND YOU CAN, IF YOU WISH, USE YOUR PRESENT MACHINE AS A DOWN-PAYMENT AND PURCHASE A COMPLETE KNITKING FOR JUST PENNIES A DAY. WRITE TODAY FOR FULL INFORMATION AND TELL US WHAT MACHINE YOU NOW OWN. THE ADDRESS IS:

KNITKING, Dept. T-1, 1128 Crenshaw Blvd., Los Angeles, Calif. - 90019

NOTES TO KNIT BY . . .

STITCH AND ROW GAUGE

KNIT A SAMPLE SWATCH . . . before you begin to knit any garment . . . for this is the MOST IMPORTANT STEP toward the correct size and the proper fit of any garment you wish to make. You MUST use the SAME YARN for your sample swatch that you will use to knit your garment and your sample swatch must be knitted large enough and using several different tension numbers on your machine. When you have done this, then you can determine the number of stitches and the number of rows in a two-inch measure. KNITTING MAGAZINE PATTERNS give you 3 tensions to try and one of them should give you the correct stitch and row gauge if you are using the yarn we recommend or a similar weight yarn. Here is the way to make your sample swatch.

Cast on over a sufficient number of needles to produce a swatch at least 4 inches wide. (If the pattern calls for 16 stitches to 2", then $16 \times 2 = 32$ stitches to cast on). Now knit 4 inches of rows at the first suggested tension number. (If the pattern calls for 22 rows to 2", $22 \times 2 = 44$ rows to knit). Knit 2 rows using a contrast color, change to the next higher tension and with garment yarn knit another 4", knit 2 rows with contrast color, change to the 3rd higher tension and knit another 4" and then bind off.



Roll the swatch into a cylinder over its length and pull on both ends, unroll it and stretch it diagonally by pulling on the four corners. Allow the swatch to rest and settle (preferably overnight) and then using a stitch gauge or a ruler, count the number of stitches over a 2" width, then the number of rows over a 2" length in EACH of the 3 tensions. Select the tension number that produces the stitches and rows called for in the pattern. If none of them are correct, you are most likely using the wrong weight of yarn.



READING OF CHARTS

You will notice the instructions start at the bottom of the Chart and work UP. Follow the charts exactly as written and providing your sample stitch and row gauge is correct, your garment will come out the right size. Please remember that the section of garment as it is knitted on the machine, faces the same way as the Charts are in this magazine. Where two front pieces are needed, (or any other part of a garment that needs two sections) only one section is normally shown and the second section is usually made with reverse shaping. Set in sleeves are usually identical, but raglan sleeves have to be knitted with reverse shaping for the second sleeve.

READING OF SYMBOLS

To simplify Pattern Knitting, we use Symbols in the Line Drawings and the Chart Diagrams. In the Line Drawings the symbols are shown and are to be read as you look at them while knitting a garment. For instance, if

a Purl stitch faces you, the Purl stitch Symbol  is shown; if a knit stitch faces you (as when using the Ribber) then this Symbol  is shown. The Symbol  at the top of the Line Drawing is the center of the garment section and you use this as a guide for setting up the needles.

The following Symbols    are used for Eyelet Designs in the Line Drawings and also for Full Fashion shaping on the Charts. The Line Drawings have row numbers on the right side. Missing Row numbers are always knitted straight or plain.

In Holding Position Designs  selected needles are pushed into holding position for the stated number of rows. The numbers of rows appear at the right of the Line Drawings; Example: 1-4 means knit Rows 1 to 4; 5 to 7 means knit Rows 5 to 7, etc. This same Symbol is also shown on the Charts and is used for putting needles into holding position for Short Rows. The

Symbol  on the Charts is used to put needles back into working position when knitting Short Rows.

A number in a box stands for the number of rows to be knitted between shapings. Make shaping first, then knit the necessary number of rows. If for instance it reads:

1 st. 8 x



1 st. 10 x





As you will be reading the instructions from the bottom up, here is the way you will follow them: . . . Decrease or increase (depending on the direction of the garment outline) 1 st. at the row where the shaping begins, then knit 8 rows, make the next decrease, then knit 8 rows, until you have decreased (or increased) 1 st. 10 x and you have knitted 8 rows after each decrease (or increase) (1 st. 10 x +8 rows 10 x). Now begin the first decrease (or increase) for the shaping (which has to be made 8 x) in every 6th row. Decrease (or increase) 1 st. first, then knit 6 rows until you have decreased 1 st. 6 x and after each decrease (or increase) have knitted 6 rows (1 st. 8 x + 6 rows 8 x).

Where shapings are given without a boxed number as on most armholes, necklines, etc., make the shapings on every second row (on each side of course).

(See below for more Pattern Stitch Symbols.)

PATTERN STITCH SYMBOLS

 = knit stitch

 = purl stitch

 = empty needle (leave in working position)

 = needle not used (in the out of work position)

 = needle in the holding position

 = Needles back into working position.

 = 2 stitches on 1 needle - either transferred from the right side or the left side, then put the needle into holding position

 = needle holding 2 stitches. Stitch has been transferred from the LEFT

 = needle holding 2 stitches. Stitch has been transferred from the RIGHT

 = 3 stitches on 1 needle. The 1st and 3rd stitch in a group of 3 needles has been hung on the 2nd or center needle.

 = Center of Garment Section.

 = Number of rows to be knitted between shapings.

The diagrams (Line Drawings) for pattern work are followed just as they are shown and are to be read as you look at them while knitting the garment.

open darts



closed darts



WEAVE KNITTING

WITH THE

Knitkng Weaving Accessory

DRESSES, SUITS, COATS,
PILLOWS, BLANKETS, ETC.

By knitting an additional thread into your basic knitting you will obtain patterns with a woven appearance. With a Knitkng Weaver, you can increase tremendously the pattern potential of your Knitkng Knitter.

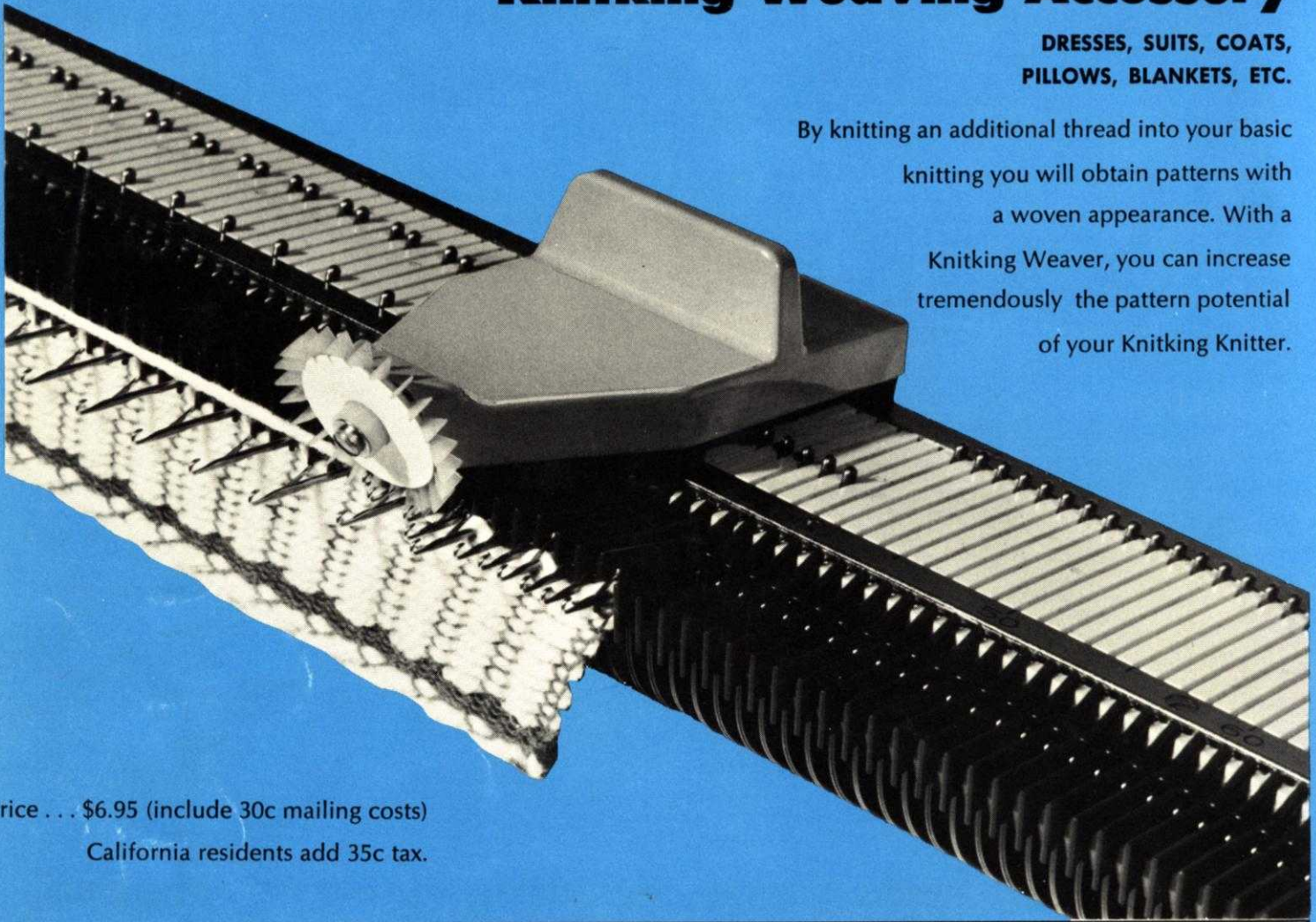

Price . . . \$6.95 (include 30c mailing costs)
California residents add 35c tax.

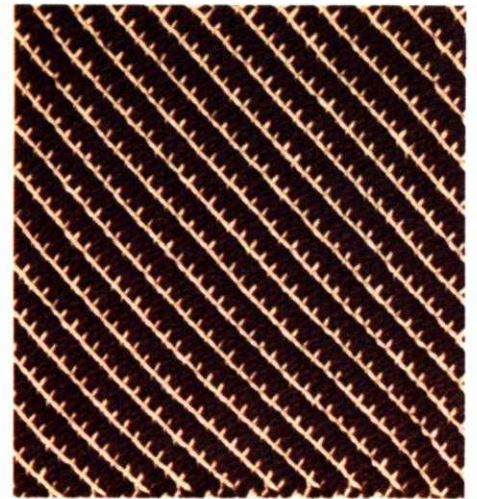
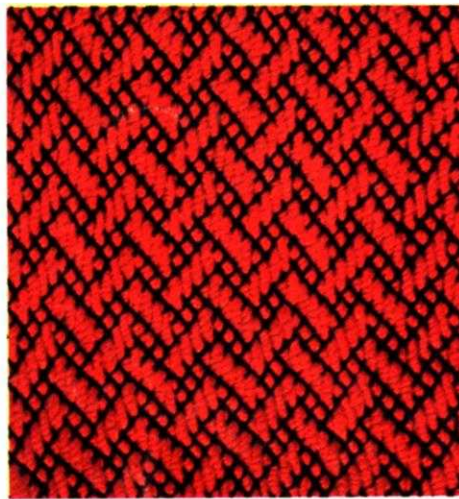
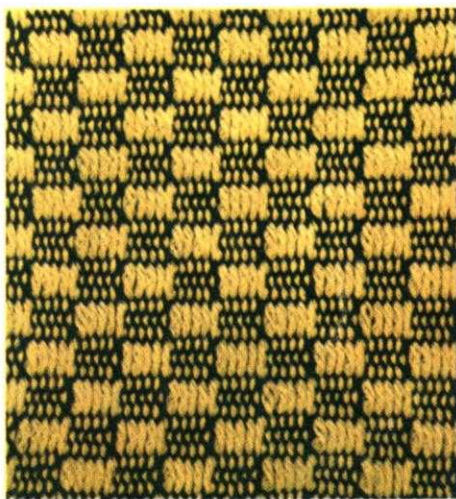

1128 Crenshaw Blvd., Los Angeles, California 90019

knitkng