

knitking

magazine

may/june '73



Another first from Knitking!!!

THE ~~WHIZ KING~~ PATTERN READER with complete Charting Service

- With **WHIZ KING** you know exactly what to do without reference to written instructions.
- With **WHIZ KING** you no longer have to count rows ... Your Pattern Chart turns automatically as you knit.
- With **WHIZ KING** you can knit even the most intricate patterns easily and speedily.
- With a **WHIZ KING** Pattern Reader, even the complete newcomer to machine knitting can immediately knit garments.
- With **WHIZ KING**, Charts are available from **KNITKING MAGAZINE** Patterns in the size of your choice.

PRICE: 49.50 Complete with instructions, practice Charts and illustrations of 50 complete Patterns for the entire family. (California residents add 5% Sales Tax)
Shipping costs \$2.50.

ORDER DIRECT FROM **KNITKING** 1128 CRENSHAW BLVD. • LOS ANGELES, CALIFORNIA 90019

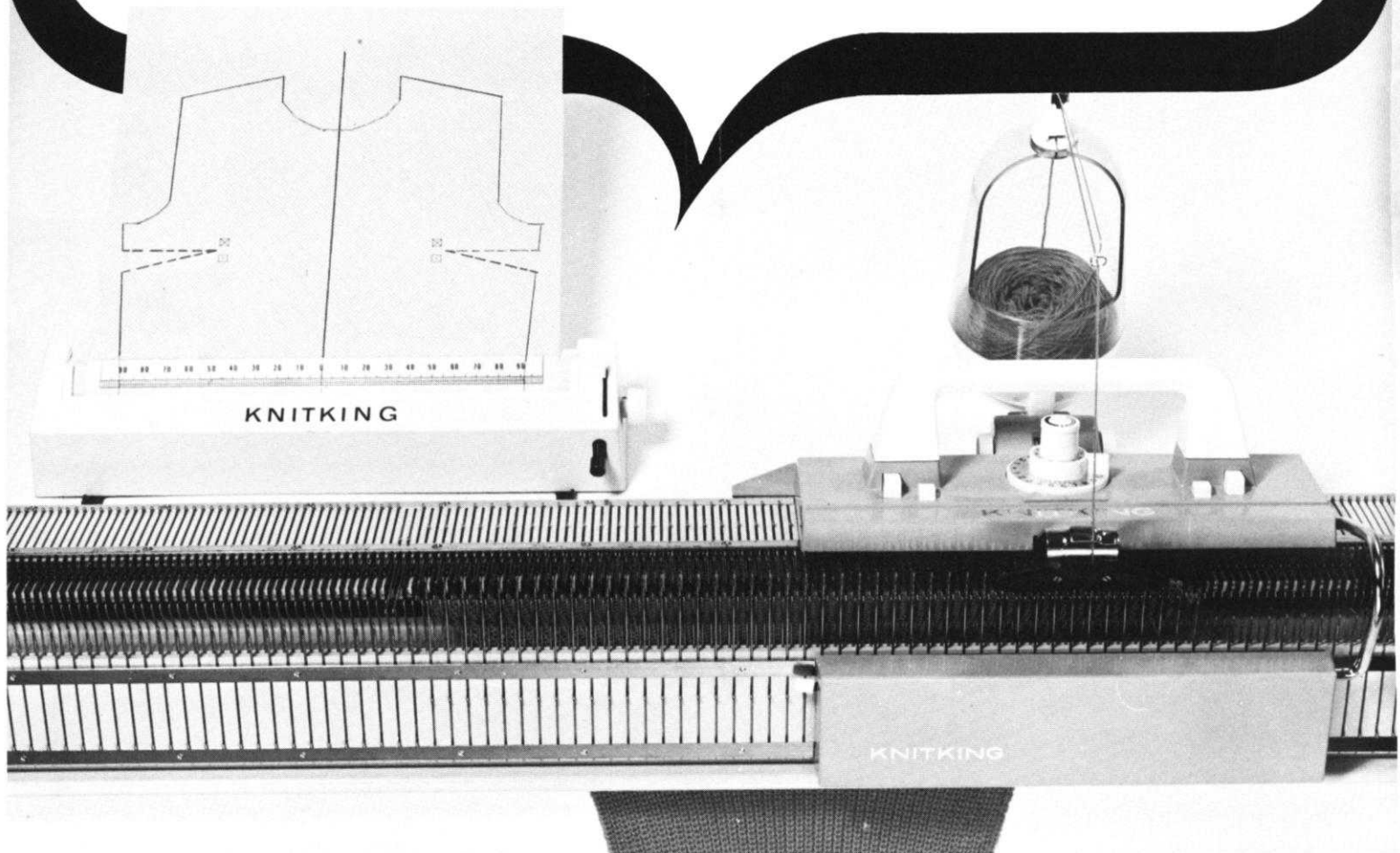

INDEX	PAGE NO.
DP 8177	Woman's Jacket 9
DP 8173	Woman's Vest 10
DK 8174	Woman's 2-piece Tennis Dress 10
HP 3697	Man's Jacket 11
DK 8154	Woman's 2-piece Dress 12
DP 8160	Woman's Pullover 12
DP 8178	Woman's Pullover 14
DP 8176	Woman's Vest 15
DP 8182	Woman's Top 15
HP 3696	Man's Sleeveless Pullover 16
MK 5421	Girl's Pullover 21
DP 8180	Woman's Twin-set 22
DK 8179	Woman's Pantsuit 23
DP 8181	Woman's Jacket 25
DP 8183	Woman's Jacket 26
MK 5417	Girl's Dress 26
KG 1958	Chair Cover 28
KG 1959	Yardstick Holder 28

We take great pride in the introduction of several more new KNITKING PRODUCTS . . . In fact, we have printed a special Four Page spread in the center of this issue to illustrate them for you . . . We are proud of our record in providing all that is best and up to date for our readers . . . We are proud of the unselfish enthusiasm of all the people that work at KNITKING . . . But, most of all, we are proud of our customer loyalty and the trust they have in our integrity . . . Many hundreds of customers have stayed with us ever since the introduction of KNITKING MAGAZINE. They buy KNITKING products sight unseen . . . confident that we stand behind everything we sell and certain that they will get a square deal from KNITKING.

MOTORIZED KNITTING MACHINES

When sewing machines were first introduced, they were hand operated. After a while, they progressed to treadle operation and finally to the modern all electric sewing machines as we know them today . . . It seemed inevitable from the day of introduction, that Home Knitting Machines would eventually be operated electrically and for many years KNITKING engineers have been working toward that goal . . . Now we introduce an extraordinarily efficient simple to operate Self Contained unit . . . You place your knitting machine on it, link the cam box to the drive mechanism . . . plug into your wall outlet and you are ready to knit . . . at the rate of 35 rows per minute.

You can do the same variety of fancy stitches as on a manual machine, but as a test we knitted sufficient yardage with HALO yarn to make a pantsuit which we cut out using a Simplicity pattern, then sewed and overlocked it on a BABY LOCK . . . The total knitting time was less than 2 hours and a good looking suit was finished in less than 4 hours. Anytime you prefer to operate your knitter by hand, all you need to do is flip up the linker . . . This is another example of the progressive policy of KNITKING.

OTHER NEW PRODUCTS

KNITKING yarn winders have always been the best available . . . Now we introduce two new winders that make the old design obsolete . . . The Hand Winder has a Waxing accessory for hard to knit yarns and the Electric Winder will certainly make many knitters very happy.

The new design KNITKING Table is well engineered . . . good looking and takes up a small amount of space . . . The Yarn Straightener is a very useful yarn saving accessory and the Carousel Transfer Tool (called Carousel because as you remove stitches from your knitter, the set of 8 tools forms a circle) makes it much easier to remove and transfer stitches without dropping them.

NEXT ISSUE OF KNITKING MAGAZINE

We just know in advance that you are going to love our July-August issue . . . It will be filled with beautiful things for everybody in the family . . . Handsome suits . . . stunning Dresses . . . an absolutely lovely Lacy Design Wedding Dress . . . a Lacy Design Pantsuit that every woman will want plus some unusually good looking Shirts and a Pullover for men and some pretty things for the children.

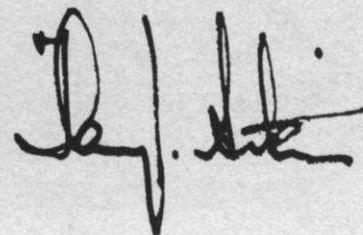

FRONTPIECE

Day time to dinner in town . . . For that important image, KNITKING rises to any occasion. Make our Cover Model Vest DP 8173 in Stockinette stitch with a beautiful Eyelet Design on the front and back sections. Size 8, 12 and 14 are all made with KNITKING Sport Prima.



BACK COVER

Somebody's angel is bursting with happiness in a peppermint striped Dress that is quickly knitted in Stockinette stitch. The front band and collar are made in one piece (See Practical Knitting Hint in this issue), so you learn a new trick. For Size 3 and Size 4, use KNITKING Beatrice Crepe; for Size 6, use Allegro Dralon.

Publisher: KNITKING CORPORATION, 1128 Crenshaw Blvd., Los Angeles, Calif. 90019. Telephone: 213-938-2079. Published bi-monthly. Subscriptions: USA - \$7.00 annually, single copies \$1.50; Canada - \$8.00; other parts of the world - \$10.00. The entire contents of KNITKING MAGAZINE are copyright and must not be reproduced in any shape or form without the express permission, in writing of the publisher. COPYRIGHT © by KNITKING CORPORATION 1973.

BOOKS by KNITTING

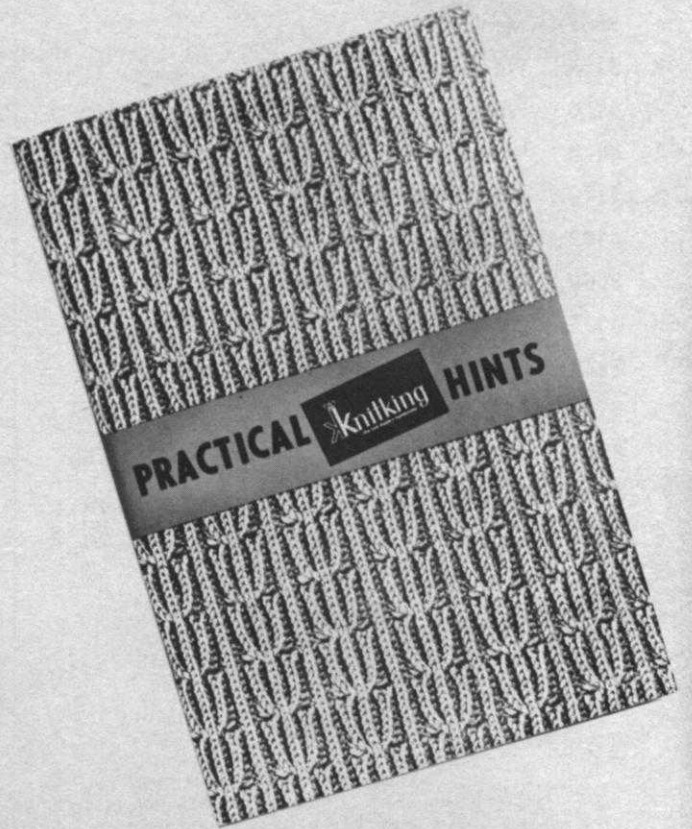

PRACTICAL KNITTING HINTS

We call this book the TEXT BOOK for machine knitters because it answers the many questions that occur in machine knitting, from preparing to knit, taking measurements, shaping, making buttonholes, special effects, bindings, bands and edges, etc., through finishing and blocking. It sells for **\$2.95**

40 cents mailing
Calif. residents add 5% Sales Tax



NEW VOLUME AVAILABLE NOW

A complete eighth volume of **KNITTING MAGAZINES** with a flexible, transparent plastic cover and specially bound so that it will stay open at any page, is available at the special price of **\$6.95** (plus 95 cents mailing costs).

If purchased separately the magazines would cost a total of **\$9.00**.

The volume contains over 120 fully illustrated complete stylish patterns for all members of the family together with many valuable, practical knitting hints.

There is a very limited number of these volumes available and it will undoubtedly become a collectors item.

If you already have the entire set it will almost certainly be well thumbed and marked. Why not purchase a perfect mint condition volume for your bookshelf and ready reference at any time.

Place your order today and avoid disappointment. Send it to **KNITTING MAGAZINE, 1128 Crenshaw Boulevard, Los Angeles, California 90019.**

DP 8177 — A plaid summer Jacket will brighten any scene . . . especially when it is knitted with KNITKING Regia. Follow the Chart for the Norwegian Design. The trim is a crochet shell stitch. Size 12 and 14.

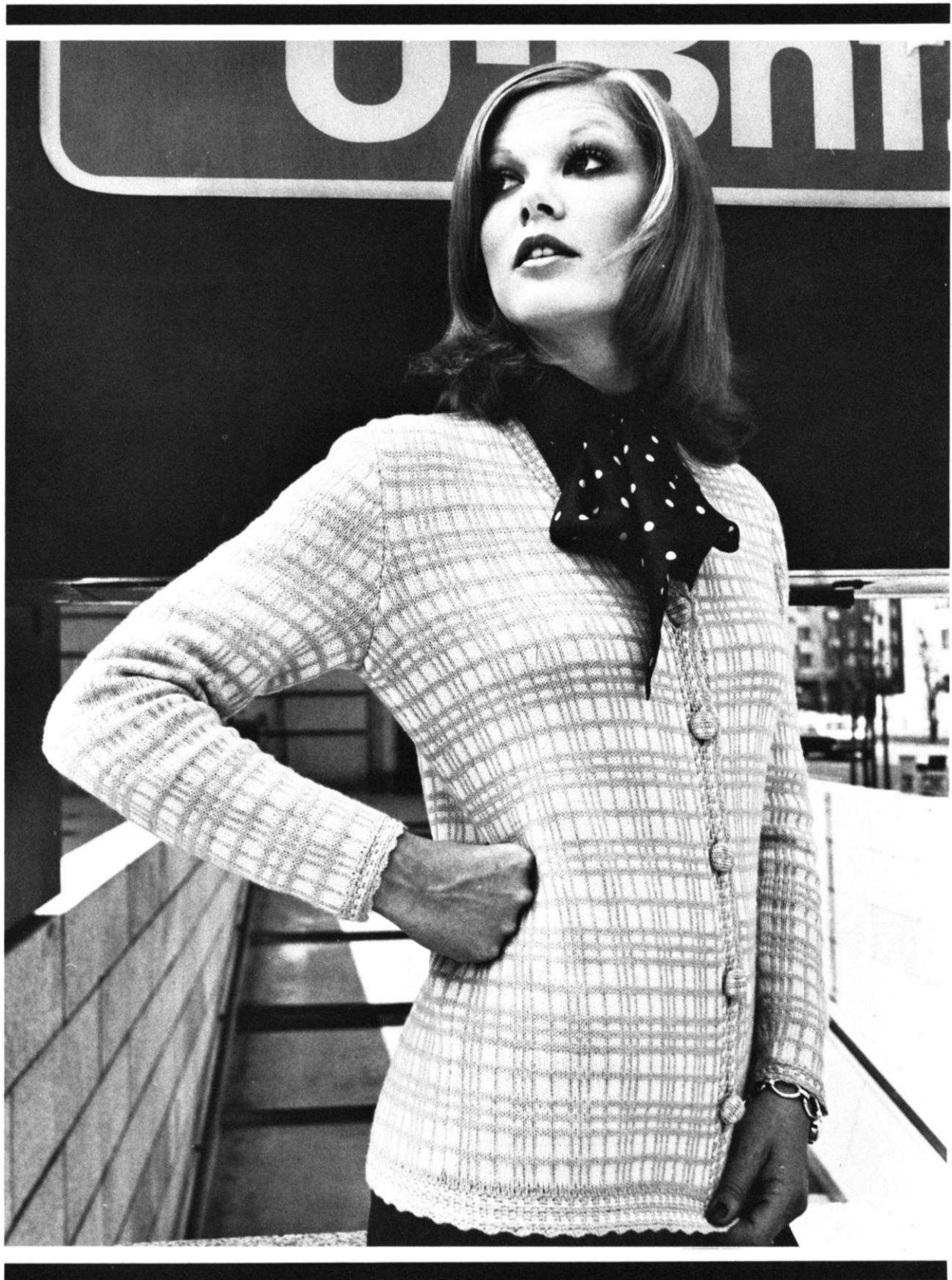



for sun and fun

DK 8174 — LOVE!!! A two-piece Tennis Dress has all the qualities you need for fast motion and bounce. The top nips in at the waist with a wide ribbed band. Knit the full Skirt using Short Rows. Size 10 is made with KNITKING Subita Crepe; Size 12 with Beatrice Crepe; Size 14 with Crocus Crepe.

HP 3697 — MORE LOVE!!! He'll make a fast play in a smartly striped Cardigan. It's knitted in easy Stockinette stitch with a 1 x 1 Rib for the Cuffs and lower Band. Size 38, Subita Crepe; Size 40, Beatrice Crepe; Size 42, Crocus Crepe.

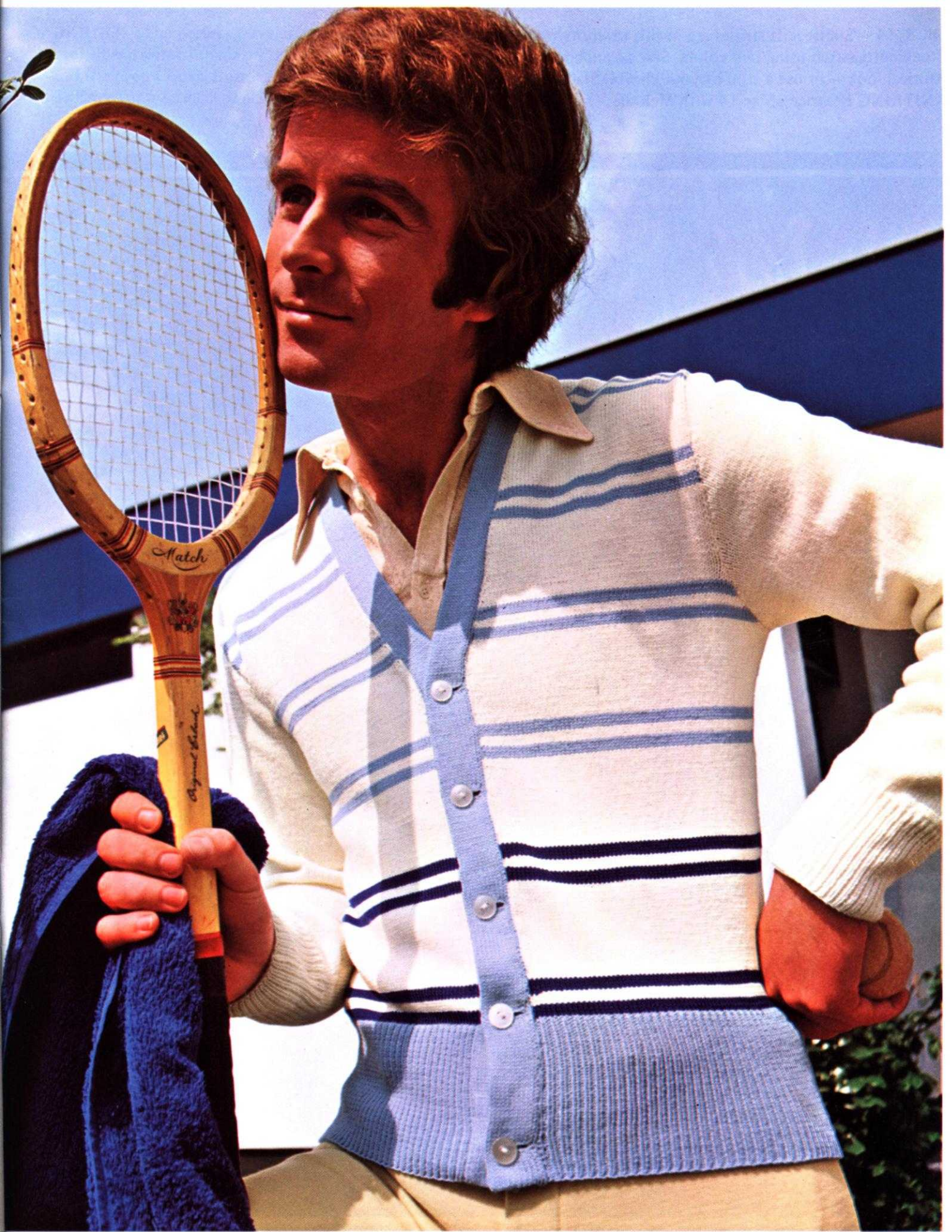

DK 8154 — Subtle soft stripes are in this lovely two-piece Dress. Knit it in easy Stockinette stitch using two colors. Sew an anchor applique on the front for a nautical look — or use a trim of your choice. Size 10 and Size 12 is made with KNITKING Beatrice; Size 14 with Melodie.



DP 8160 — The perfect traveler . . . Look fresh and crisp in a newly designed Pull-over. It buttons to there on the front and has bright color stripes on the sleeves and the deep Collar. Knit it in Stockinette stitch using two colors of KNITTING Beatrice for a Size 16 or a Size 18; Melodie for Size 22.



Blue Mood

DP 8178 — Pop on a new up-to-the-minute sleeveless Pull-over. Knit it in a two color Norwegian Design. The wide ribbed Waistband is part of the big sweater look for '73. Use KNITKING Beatrice Crepe for Size 8; Allegro Dralon for Size 10; Mohana for Size 14.

DP 8176 — Chill Chaser . . . Wherever you go, you will want this super crossover Vest to wear again and again over a Dress or a Blouse. Knit it in Stockinette stitch with Ribbed Bands. Size 8 is made with KNITKING Beatrice Crepe; Size 10 with Allegro Dralon; Size 14 with Mohana.





NEW! NEW!! NEW!!!

1. THREE COLOR YARN FEEDER

For Easy Multi-Color Knitting - Jacquard Designs, etc. Feeders are Self-Adjusting. Fits AM 3 Model KNITKING only. Price - \$17.50 plus \$1.50 Shipping costs (Calif. residents add 88 cents Sales Tax).

2. AUTOMATIC COMPENSATOR FOR INCREASING - DECREASING

Simple to use . . . Overcomes the need to reset Dial when increasing or decreasing . . .

Send your AM 3 Cam Box to KNITKING (pack it in a good sized box stuffed with tightly rolled sheets of newspaper). We will service it completely . . . fit new Controls and supply new set (eleven) of Cams. Your old Cams are not suitable for the new Controls.

Price - \$19.50 plus \$2.00 Shipping costs (Calif. residents add 98 cents Sales Tax).

Order Direct From **KNITKING**

1128 Crenshaw Blvd. • Los Angeles, California 90019

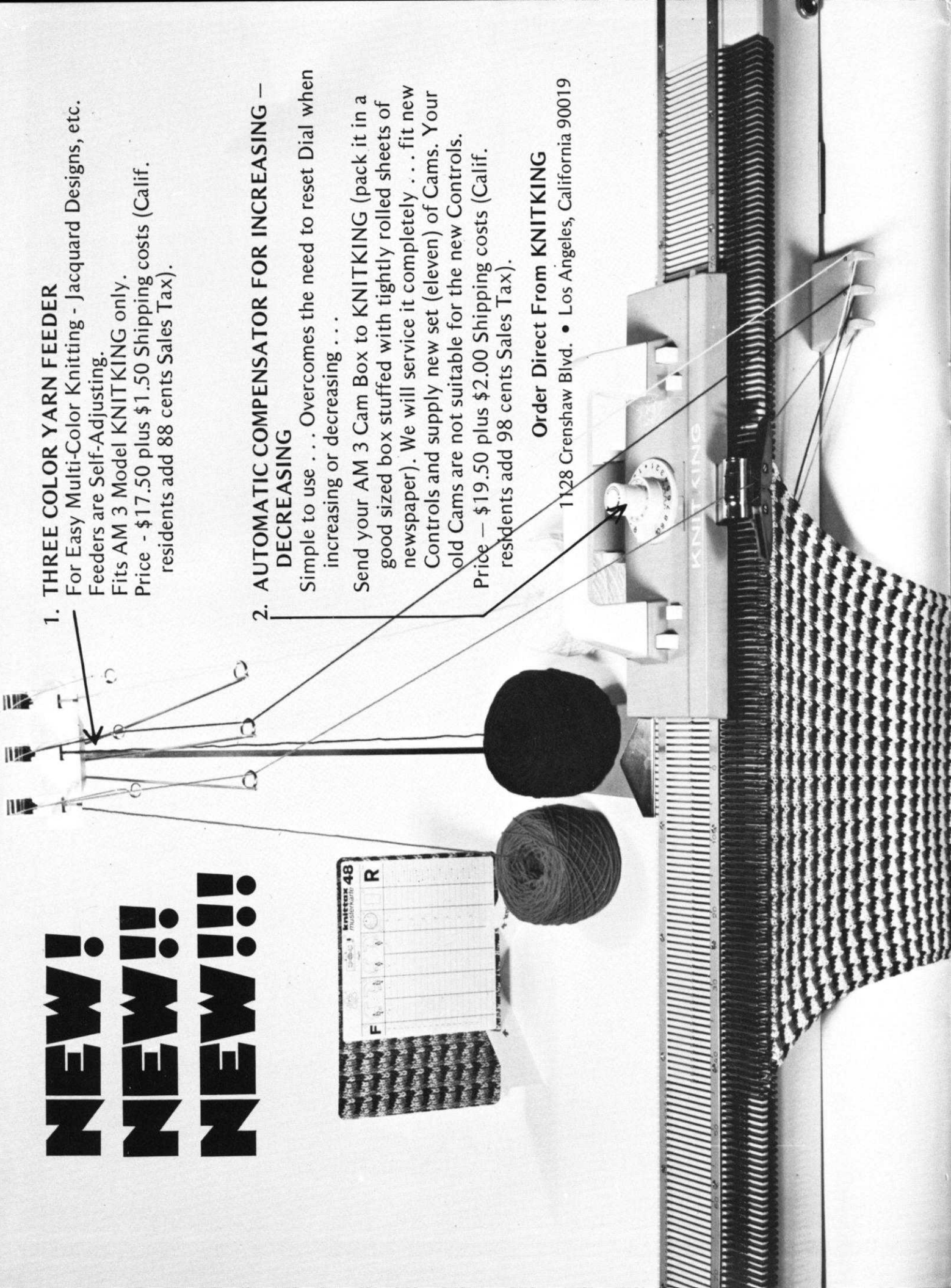
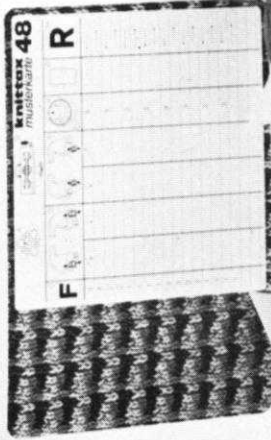

DPS177

SIZE:	12 (Bust 34"-35")	14 (Bust 36"-37")
YARN:	Regia	Regia
50 gr. BALLS:	5 color 1 4 color 2	6 color 1 5 color 2
TENSION:	4 to 6	5 to 7
GAUGE:	2" 18 sts. 23 rows	17 sts. 22 rows

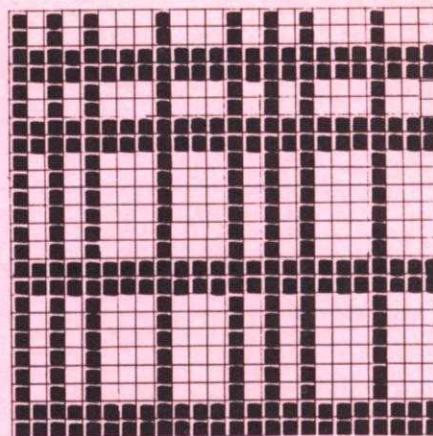

The instructions are the same for both sizes. PATTERN: Norwegian Design according to the Line Drawing. Use the adjustable needle selector. In the instructions, each row in the Norwegian Design is counted as 1 row, but several movements of the Cam Box are needed to complete 1 row. EDGES: Crochet. To increase, place the end st. from the row below onto the next empty needle.

FINISHING: Block all sections. Join back and front sections at sides and shoulders. Sew the sleeves together and set in. Crochet around front, neck and lower edge as follows:

ROW 1: With Color 1, single crochet around.

ROW 2: With Color 1, work 1 sc in first st., ch 1, *skip 1, 1 sc in next st., ch 1, REPEAT from * around.

ROW 3: With Color 2 sc into ch 1 space; *ch 1, sc in next ch 1 space; REPEAT from * around.

ROW 4: With Color 1, Repeat Row 3, but on the RIGHT SIDE. make 5 buttonholes beginning about 2 1/4" from lower edge and space 2 1/4" apart by chaining 5; skip 5, for each buttonhole.

ROWS 5 & 6: With Color 1, REPEAT ROW 3.

ROW 7: With Color 2, REPEAT Row 3.

ROW 8: With Color 1, work picot; *ch 2, sc into 2nd ch from hook; ch 1, skip 2, sc in next st. REPEAT from * around.

SLEEVE: Crochet 4 rows the same as above, working the 3rd row with Color 2, then work 1 row of picots as Row 8 using Color 1.

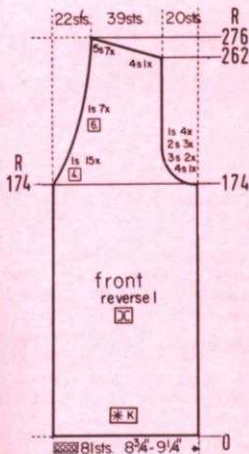

Work the second front section with reverse shapings, casting on from right to left.

ON OPPOSITE SIDE of CAM BOX (NECK SIDE), decrease 1 st. after Rows in (). ON CAM BOX SIDE, bind off 4 sts. after Row 174; (174), 3 sts. after Rows 176, 178; (178), 2 sts. after Rows 180, 182, (182), 184; 1 st. after Rows 186, (186), 188, 190, (190), 192. The Armhole Shaping is now completed. Continue to decrease 1 st. ON NECK SIDE after Rows 194, 198, 202, 206, 210, 214, 218, 222, 226, 230, 234, 240, 246, 252, 258, then again after Rows in (). For SHOULDER bind off 4 sts. after Row 262; 5 sts. after Rows 264, (264), 266, 268, 270, (270), 272, 274, 276.

ROWS 0 to 174: Knit even.

Cast on 81 sts. with color 1 and work the Norwegian Design.

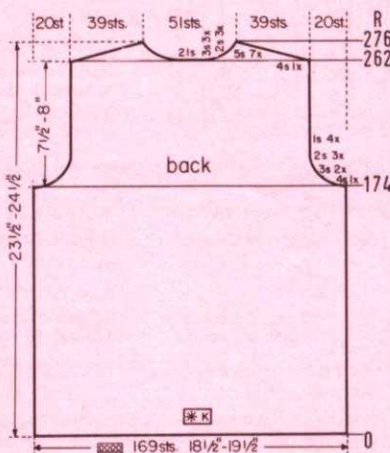

Bring the needles on the left side into working position, knit 1 row in PATTERN to the left side, turn the Row Counter back to 262 and complete the left half. Follow the instructions from*.

*ON CAM BOX SIDE, bind off 4 sts. after Row 262 (EVEN ROWS = SHOULDER SHAPING); 3 sts. after Row 263 (ODD ROWS = NECK SHAPING); 5 sts. after Row 264; 3 sts. after Row 265; 5 sts. after Row 266; 3 sts. after Row 267; 5 sts. after Row 268; 2 sts. after Row 269; 5 sts. after Row 270; 2 sts. after Row 271; 5 sts. after Row 272; 2 sts. after Row 273; 5 sts. after Rows 274, 276.

ON CAM BOX SIDE, bind off 4 sts. after Rows 174, 175; 3 sts. after Rows 176, 177, 178, 179; 2 sts. after Rows 180, 181, 182, 183, 184, 185; 1 st. after Rows 186, 187, 188, 189, 190, 191, 192, 193, then knit to Row 262, bind off the center 21 sts., put the needles on the left side into holding position and complete the right half first.

ROWS 0 to 174: Knit even.

Cast on 169 sts. with color 1 and work the Norwegian Design.

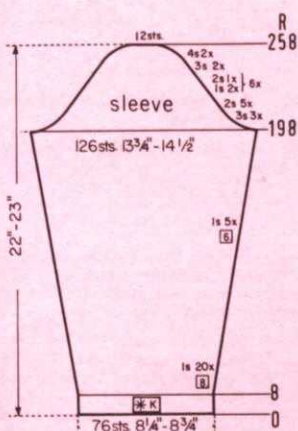

ON CAM BOX SIDE, bind off 3 sts. after Rows 198, 199, 200, 201, 202, 203; 2 sts. after Rows 204, 205, 206, 207, 208, 209, 210, 211, 212, 213; 1 st. after Rows 214, 215, 216, 217; 2 sts. after Rows 218, 219; 1 st. after Rows 220, 221, 222, 223; 2 sts. after Rows 224, 225; 1 st. after Rows 226, 227, 228, 229; 2 sts. after Rows 230, 231; 1 st. after Rows 232, 233, 234, 235; 2 sts. after Rows 236, 237; 1 st. after Rows 238, 239, 240, 241; 2 sts. after Rows 242, 243; 1 st. after Rows 244, 245, 246, 247; 2 sts. after Rows 248, 249; 3 sts. after Rows 250, 251, 252, 253; 4 sts. after Rows 254, 255, 256, 257; 12 sts. after Row 258.

ON EACH SIDE, increase 1 st. after Rows 8, 16, 24, 32, 40, 48, 56, 64, 72, 80, 88, 96, 104, 112, 120, 128, 136, 144, 152, 160, 168, 174, 180, 186, 192, then knit to Row 198.

ROWS 0 to 8: Knit even.

Cast on 76 sts. with color 1 and work the Norwegian Design.

BE SURE TO NOTIFY US IMMEDIATELY OF ANY CHANGE OF ADDRESS. THE POST OFFICE WILL NOT FORWARD YOUR MAGAZINE TO YOU.

DP 8173

SIZE:	8 (Bust 31"-32")	12 (Bust 33"-34")	14 (Bust 36"-37")
YARN:	Sport Prima	Sport Prima	Sport Prima
50 gr. BALLS:	7	8	9
TENSION:	7 to 9	8 to 10	9 to 10
GAUGE:	2" 15 sts. 20 rows	14 sts. 19 rows	13 sts. 18 rows



The instructions are the same for all sizes. **PATTERN:** Stockinette Stitch and Eyelet Design according to the Line Drawing. **Decreases:** **SIDES:** Hang the 3rd st. onto the 2nd st., then move the end sts. inward to fill the empty needle. **FRONT EDGE:** Hang the 14th st. ON **FRONT EDGE** onto the 13th sts., then move the end sts. inward to fill the empty needle. **Increases:** Move the 2 end sts. 1 needle outward, then place the 3rd st. from the row below onto the empty needle.

FINISHING: Block the sections. Join back and front sections at sides and shoulders. Weave the open sts. of the facing together, then sew the facing to neckline. Turn under 16 Rows on lower edge, 11 sts. on front edges and neckline and hem to wrong side. Join the short ends of the armhole facings, then sew the facings to the armholes, turn to wrong side and hem in place. Finish the buttonholes, sew on buttons.

DP 8173 Line Drawing

EACH Eyelet Design Stripe is worked over 31 sts. as marked on the Diagrams. 1. ON EACH SIDE of the Stripe Center, hang the 7th st. onto the 8th st. and the 15th st. onto the 16th st. 2. ON EACH SIDE on the Stripe Center, move the 1st-6th and 9th-14th sts. 1 needle to the right - left side - respectively. 3. Bring the empty needles into working position and knit 2 rows. 4. ON EACH SIDE of the Stripe Center, hang the 7th st. onto the 8th st. and the 15th st. onto the 16th st. 5. ON EACH SIDE of the Stripe Center, move the 2nd-6th and 10th-14th sts. 1 needle to the right-left side-respectively. 6. Bring the empty needles into working position and knit 2 rows. ETC.

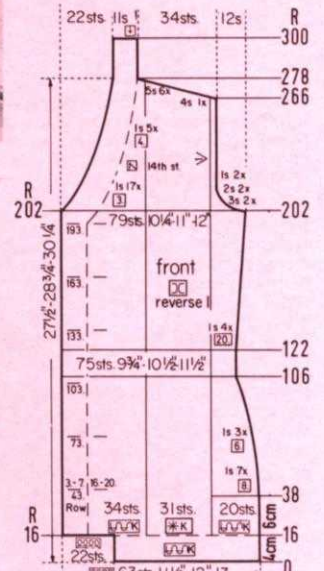
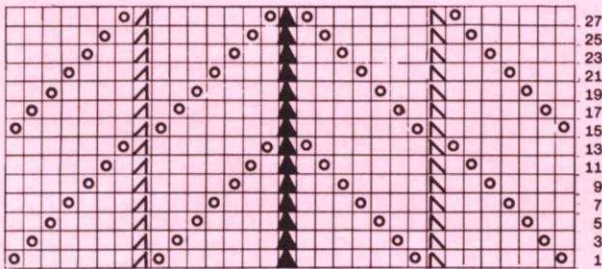

DK 8174

SIZE:	10 (Bust 31"-32")	12 (Bust 33"-34")	14 (Bust 36"-37")
YARN:	Subita Crepe 2 x 3	Beatrice Crepe	Crocus Crepe
50 gr. BALLS:	9	12	14
TENSION:	3 to 5	3 to 5	5 to 7
GAUGE:	2" Stock: 18 sts. 25 rows Ribbing: 18 sts. 28 rows	17 sts. 24 rows 17 sts. 27 rows	16 sts. 23 rows 16 sts. 26 rows

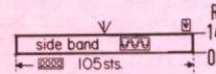

Cast on 105 sts. and work 14 rows K1, P1, Ribbing, then bind off all sts.

The instructions are the same for all sizes. **PATTERN:** Stockinette Stitch. The Skirt is knitted sideways on the machine. **EDGES:** K1, P1, Ribbing.

FINISHING: Block all sections. **TOP:** Join front and back section at sides and shoulders. Join the short ends of the armhole bands, then sew the bands in place. Sew the side band to the right side seam and trim with buttons. (see picture). Work 2 rows of single crochet around the neckline. **SKIRT:** Weave the sts. together that are held on waste yarn, leaving 6" open at the waistline. Slip st. crochet the remaining open sts. then sew a zipper into the opening. Sew an elastic waist band to the wrong side at the waistline. Turn under about 2" for hem.



Repeat ROWS 0 to 58 17 times more, but the LAST time, knit only to ROW 57. (The last row will be made up when weaving the open sts. together). Knit several rows with contrast waste yarn, then remove the knitting from the machine.

ON OPPOSITE SIDE of CAM BOX, put into holding position 94 needles after Row 10. ON OPPOSITE SIDE of CAM BOX bring back into working position 10 needles after Rows 12, 14, 16, 18, 20, 22, 24, 26, 28, (4 needles remain). ON OPPOSITE SIDE of CAM BOX put into holding position 10 needles after Rows 30, 32, 34, 36, 38, 40, 42, 44, 46. Bring all needles back into working position after Row 48, then knit even to Row 58. One section of the skirt is now completed.

ROWS 0 to 10: Knit even.

Cast on 126 sts. with contrast waste yarn (open Cast-on), knit several rows, ending with the Cam Box on the right side. Change to the garment yarn and turn the Row Counter to 0. Work stockinette st. and Short Rows.

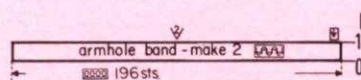
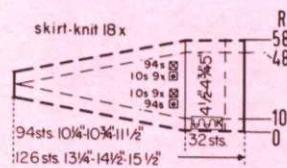
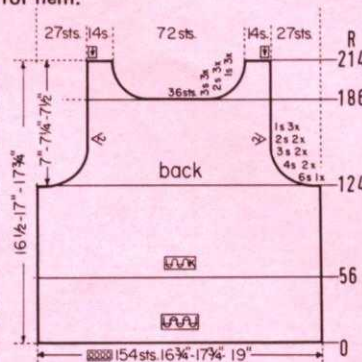

Cast on 196 sts. and work 14 rows K1, P1, Ribbing, then bind off all sts.

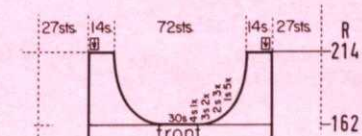

Move the Cam Box to the left side, turn the Row Counter back to 186 and complete the left half. Follow the instructions from*.

*ON CAM BOX SIDE, bind off 3 sts. after Rows 187, 189; 2 sts. after Rows 193, 195, 197; 1 st. after Rows 199, 201, 203. After Row 214 bind off the 14 Shoulder sts.

ON CAM BOX SIDE, bind off 6 sts. after Rows 124, 125; 4 sts. after Rows 126, 127, 128, 129; 3 sts. after Rows 130, 131, 132, 133; 2 sts. after Rows 134, 135, 136, 137; 1 st. after Rows 138, 139, 140, 141, 142, 143, then knit to Row 186, bind off the center 36 sts., put the needles on the left side into holding position and complete the right half first. (For the Front Section knit to Row 162).

ROWS 57 to 124: Knit even.

ROWS 0 to 56: Knit even, then change to stockinette st.

Cast on 154 sts. and work K1, P1, Ribbing.

Move the Cam Box to the left side, turn the Row Counter back to 162 and complete the left half. Follow the instructions from*.

*ON CAM BOX SIDE, bind off 4 sts. after Row 163; 3 sts. after Rows 165, 167; 2 sts. after Rows 169, 171, 173; 1 st. after Rows 175, 177, 179, 181, 183. After Row 214 bind off the 14 Shoulder sts.

Work the front section the same as the back section to ROW 162, then bind off the center 30 sts., put the needles on the left side into holding position and complete the right half first.

Work the second front section with reverse shapings, casting on from right to left. (Cam Box will be on the LEFT side at Row 0). Omit the buttonholes.

Decrease 1 st. ON NECK SIDE after Rows in (). ON CAM BOX SIDE, bind off 3 sts. after Rows 202, (202), (204); (205), 2 sts. after Rows 206, 208; (208), 1 st. after Rows 210, (211), 212. The Armhole Shaping is now completed. Continue to decrease 1 st. ON NECK SIDE after Rows 214, 217, 220, 223, 226, 229, 232, 235, 238, 241, 244, 247, 250, 253, 257, 261, 265, then 1 more time after Row in (). For SHOULDER bind off 4 sts. after Row 266; 5 sts. after Rows 268, (269), 270, 272, 274, 276, 278. Work over the remaining 11 sts. (FACING) to Row 300, then put the sts. onto a stitch holder.

Continue to make buttonholes after Rows in (). ON CAM BOX SIDE, increase 1 st. after Rows 122, (133), 142, 162, (163), 182, (193), then knit to Row 202.

Make buttonholes over the 3rd-7th and 16th-20th sts. counting from the left side after Rows in (). ON CAM BOX SIDE, decrease 1 st. after Rows 38, (43), 46, 54, 62, 70, (73), 78, 86, 94, 100, (103), 106, then knit to Row 122.

ROWS 17 to 38: Knit even.

ROWS 0 to 16: Knit even, then cast on 22 sts. ON OPPOSITE SIDE of CAM BOX, (use a separate length of yarn) then begin the Eyelet Design over the 31 sts. marked on the Diagram.

Cast on 63 sts. and work stockinette st.

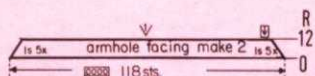

Cast on 118 sts. and work stockinette st. Decrease 1 st. ON EACH SIDE after Rows 2, 4, 6, 8, 10. After Row 12 bind off all sts.

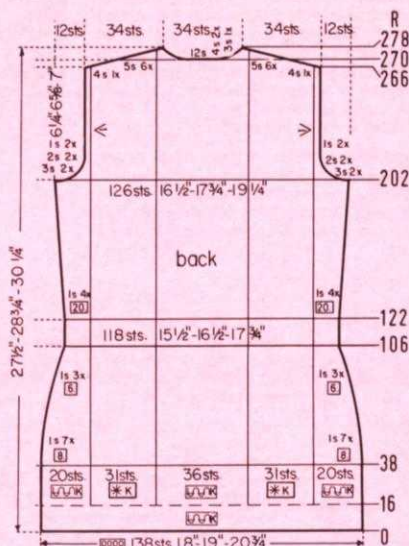

Bring the needles on the left side into working position, knit 1 row in PATTERN to the left side, turn the Row Counter back to 270 and complete the left half. Follow the instructions from*.

*ON CAM BOX SIDE, bind off 5 sts. after Row 270 (EVEN ROWS = SHOULDER SHAPING); 4 sts. after Row 271 (ODD ROWS = NECK SHAPING); 5 sts. after Row 272; 4 sts. after Row 273; 5 sts. after Row 274; 3 sts. after Row 275; 5 sts. after Rows 276, 278.

ON CAM BOX SIDE, bind off 4 sts. after Rows 266, 267; 5 sts. after Rows 268, 269, then knit to Row 270, bind off the center 12 sts., put the needles on the left side into holding position and complete the right half first.

ON CAM BOX SIDE, bind off 3 sts. after Rows 202, 203, 204, 205; 2 sts. after Rows 206, 207, 208, 209; 1 st. after Rows 210, 211, 212, 213, then knit to Row 266.

ON EACH SIDE, increase 1 st. after Rows 122, 142, 162, 182, then knit to Row 202.

ON EACH SIDE, decrease 1 st. after Rows 38, 46, 54, 62, 70, 78, 86, 94, 100, 106, then knit to Row 122.

ROWS 17 to 38: Knit even.

ROWS 0 to 16: Knit even, then begin the Eyelet Design over the sts. marked on the Diagram.

Cast on 138 sts. and work stockinette st.

HP3697

SIZE:	38 (Chest 37"-38")	40 (Chest 39"-40")	42 (Chest 42"-43")
YARN:	Subita Crepe 2 x 3	Beatrice Crepe	Crocus Crepe
50 gr. BALLS:	6 color 1 3 color 2 1 color 3	7 color 1 3 color 2 1 color 3	9 color 1 4 color 2 1 color 3
TENSION:	3 to 5	3 to 5	5 to 7
GAUGE:	2" Stock: 18 sts. 25 rows Ribbing: 18 sts. 28 rows	17 sts. 24 rows 17 sts. 27 rows	16 sts. 23 rows 16 sts. 26 rows

The instructions are the same for all sizes. PATTERN: Stockinette Stitch and color stripes as marked in the Diagrams. EDGES: K1, P1, Ribbing. INCREASES: Move the 2 end sts. 1 needle outward, then place the 3rd st. from the row below onto the empty needle. FRONT DECREASES: ON NECK SIDE, hang the 3rd st. onto the 2nd st., then move the end sts. inward to fill the empty needle.

FINISHING: Block all sections. Join back and front sections at sides and shoulders. Sew the sleeves together and set in. Sew 1 edge of the band to inside and 1 edge to the outside of front edges and neckline. (Buttonholes on the LEFT side). Finish the buttonholes, sew on buttons.



Work the second front section with reverse shapings, casting on from right to left. (Cam Box will be on the LEFT side at Row 0).

Decrease 1 st. ON OPPOSITE SIDE of CAM BOX (NECK SIDE) after Rows in (). ON CAM BOX SIDE, bind off 5 sts. after Row 180; (180), 3 sts. after Rows 182, 184; (184), 2 sts. after Rows 186, 188; (188), 1 st. after Rows 190, 192, (192), 194, 196, (196), 198. The Armhole Shaping is now completed. Continue to decrease 1 st. ON NECK SIDE after Rows 200, 204, 210, 216, 222, 228, 234, 240, 246, 252, 258, 264, 270, 276, 282, then again after Rows in (). For SHOULDER bind off 3 sts. after Row 286; 4 sts. after Rows 288, (288), 290, 292, 294, (294), 296, 298, 300, (300), 302, 304, 306.

ON CAM BOX SIDE, increase 1 st. after Rows 56, 80, 104, 128, 152, then knit to Row 180.

ROWS 0 to 56: Knit even, then change to stockinette st. and work the color stripes as marked in the Diagram.

Cast on 81 sts. with color 2 and work K1, P1, Ribbing.

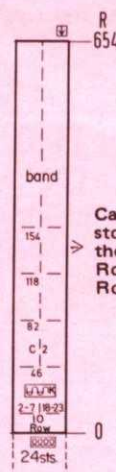
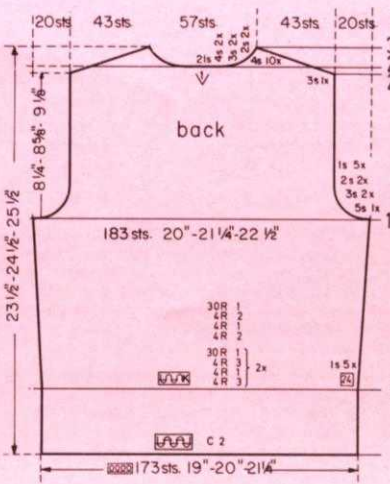
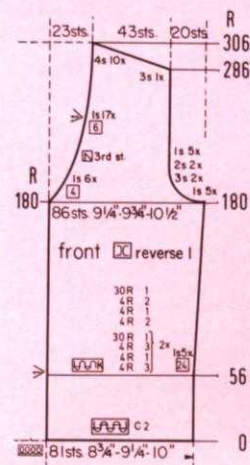

Cast on 24 sts. with color 2 and work stockinette st. Make buttonholes over the 2nd-7th and 18th-23rd sts. after Rows 10, 46, 82, 118, 154, then knit to Row 654 and bind off all sts.

Move the Cam Box to the left side, turn the Row Counter back to 292 and complete the left half. Follow the instructions from*.

*ON CAM BOX SIDE, bind off 4 sts. after Rows 292 (EVEN ROWS = SHOULDER SHAPING); 293 (ODD ROWS = NECK SHAPING), 294, 295, 296; 3 sts. after Row 297; 4 sts. after Row 298; 3 sts. after Row 299; 4 sts. after Row 300; 2 sts. after Row 301; 4 sts. after Row 302; 2 sts. after Row 303; 4 sts. after Rows 304, 306.

ON CAM BOX SIDE, bind off 3 sts. after Rows 286, 287; 4 sts. after Rows 288, 289, 290, 291, then knit to Row 292, bind off the center 21 sts., put the needles on the left side into holding position and complete the right half first.

ON CAM BOX SIDE, bind off 5 sts. after Rows 180, 181; 3 sts. after Rows 182, 183, 184, 185; 2 sts. after Rows 186, 187, 188, 189; 1 st. after Rows 190, 191, 192, 193, 194, 195, 196, 197, 198, 199, then knit to Row 286.

ON EACH SIDE, increase 1 st. after Rows 56, 80, 104, 128, 152, then knit to Row 180.

ROWS 0 to 56: Knit even, then change to stockinette st. and work the color stripes as marked in the Diagram.

Cast on 173 sts. with color 2 and work K1, P1, Ribbing.

Continued on page 13

DK8154

SIZE:	10 (Bust 32"-33")	12 (Bust 34"-35")	14 (Bust 36"-37")
YARN:	Beatrice Crepe	Beatrice Crepe	Melodie
50 gr. BALLS:	13 color 1 1 color 2	13 color 1 1 color 2	16 color 1 1 color 2
TENSION:	4 to 6	5 to 7	6 to 8
GAUGE:	2" 17 sts. 23 rows	16 sts. 22 rows	15 sts. 21 rows

The instructions are the same for all sizes. PATTERN: Stockinette Stitch with color stripes as marked in the Diagrams. DECREASES: Hang the 4th st. onto the 3rd st., then move the end sts. inward to fill the empty needle. Begin the Skirt Darts by hanging the sts. together as marked in the Diagrams, then move the sts. over to fill the empty needles. The following decreases for the Darts lie directly above. INCREASES: Move the 2 end sts. 1 needle outward, then place the 3rd st. from the row below onto the empty needle. To form the hem, hang the cast-on sts. back onto the machine behind the latches, then knit the following row with 1 or 2 tension settings higher. (You may omit hanging the hems and sew them by hand).

FINISHING: Block all sections. SKIRT: Weave the sections together, 1 st. in from each edge. Turn under 13 rows on the upper edge and hem to wrong side, then insert an elastic band. TOP: Join front and back section at sides and shoulders. Sew the sleeves together and set in. Sew 1 edge of the neckband to inside and 1 edge to outside of the neckline. Work 1 row of slip-stitch crochet around the back opening, then sew in a zipper. Sew a anchor applique to the front as shown in the picture.

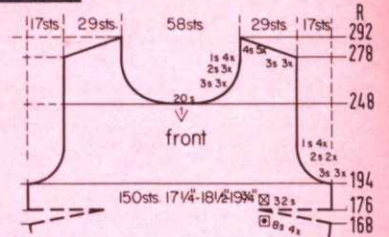

ON CAM BOX SIDE, bind off 4 sts. after Rows 62, 63, 64, 65; 3 sts. after Rows 66, 67, 68, 69; 2 sts. after Rows 70, 71, 72, 73. ON EACH SIDE, hang the 1st st. onto the 2nd st. after Rows 74, 76, 78, 80, 82, 84, 86, 88, 90, 92, 94, 96, 98, 100, 102, 104, 106, 108, 110. ON CAM BOX SIDE, bind off 2 sts. after Rows 112, 113, 114, 115; 3 sts. after Rows 116, 117; 4 sts. after Rows 118, 119; 13 sts. after Row 120.

ON EACH SIDE, increase 1 st. after Rows 22, 26, 30, 34, (continue with color 1 after Row 36) 38, 42, 46, 50, 54, 58, then knit to Row 62.

ROWS 0 to 22: Knit even, then form the hem, change to color 2 and work the color stripes as marked in the Diagram.

Cast on 89 sts. with color 1 and work stockinette st.

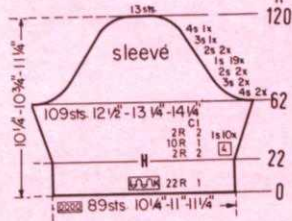

Move the Cam Box to the left side, turn the Row Counter back to 270 and complete the left half. Follow the instructions from*.

ON CAM BOX SIDE, bind off 3 sts. after Row 270 (EVEN ROWS = SHOULDER SHAPING); 9 sts. after Row 271 (ODD ROWS = NECK SHAPING); 3 sts. after Row 272; 5 sts. after Row 273; 3 sts. after Row 274; 5 sts. after Row 275; 4 sts. after Row 276; 3 sts. after Row 277; 4 sts. after Row 278; 3 sts. after Row 279; 4 sts. after Row 280; 2 sts. after Row 281; 4 sts. after Row 282; 2 sts. after Row 283; 4 sts. after Row 284.

*ROWS 245 to 270: Knit even.

ON CAM BOX SIDE, bind off 3 sts. after Rows 186, 187, 188, 189, 190, 191; 2 sts. after Rows 192, 193, 194, 195; 1 st. after Rows 196, 197, 198, 199, 200, 201, 202, 203, then knit to Row 244, put 58 needles on the left side into holding position and complete the right half first.

ON EACH SIDE, increase 1 st. after Rows 106, 118, 130, 142, 154, 166, then knit to Row 186. (For the Front Section knit to ROW 168).

ON EACH SIDE, increase 1 st. after Rows 40, 50, (continue with color 1 after Row 52) 60, 70, 80, 90, then knit to Row 106.

ROWS 37 to 40: Knit even.

ROWS 0 to 36: Knit even, then form the hem, change to color 2 and work the color stripes as marked in the Diagram.

Cast on 150 sts. with color 1 and work stockinette st.

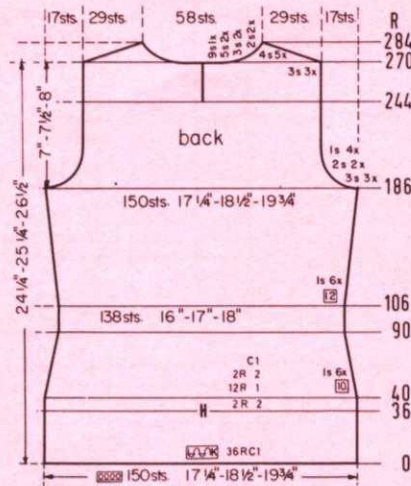
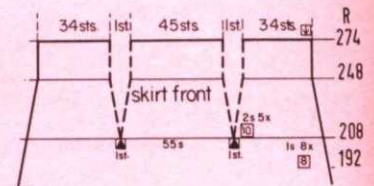

DPS160

SIZE:	16 (Bust 38"-39")	18 (Bust 40"-41")	22 (Bust 43"-44")
YARN:	Beatrice Crepe	Beatrice Crepe	Melodie
50 gr. BALLS:	7 color 1 2 color 2	7 color 1 2 color 2	9 color 1 2 color 2
TENSION:	4 to 6	5 to 7	6 to 8
GAUGE:	2" 17 sts. 23 rows	16 sts. 22 rows	15 sts. 21 rows

The instructions are the same for all sizes. PATTERN: Stockinette Stitch and color stripes on the sleeves and on the collar as marked in the Diagram. INCREASES: Move the 2 end sts. 1 needle outward, then place the 3rd st. from the row below onto the empty needle. DECREASES: Hang the 3rd st. onto the 2nd st., then move the end sts. inward to fill the empty needle. To form the hem, hang the cast-on sts. back onto the machine behind the latches, then knit the following row with 1 or 2 tension settings higher. (You may omit hanging the hems and sew them by hand).

FINISHING: Block all sections. Join front and back sections at sides and shoulders. Sew the sleeves together and set in. Turn under 13 sts. on the front edges (Facing) and hem to wrong side. Sew the under-lap edge on lower edge of the front opening in place. Fold the collar in half and sew the front edges together. Sew 1 edge of the collar to inside and 1 edge to the outside of the neckline, leaving 3/4" on each front edge free. Finish the buttonholes, sew on buttons.

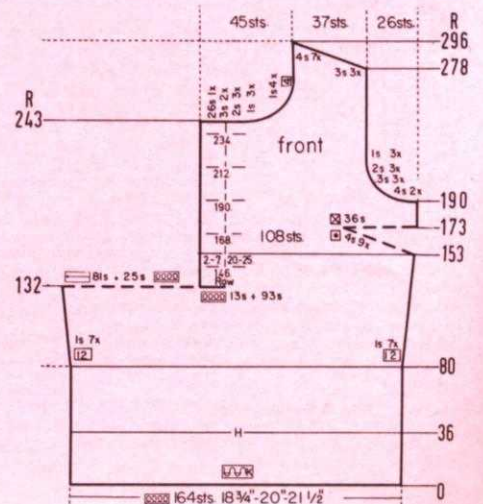

Move the Cam Box to the left side, turn the Row Counter back to 248 and complete the left half. Follow the instructions from*.

*ON CAM BOX SIDE, bind off 3 sts. after Rows 249, 251, 253; 2 sts. after Rows 255, 257, 259; 1 st. after Rows 261, 263, 265, 267. For SHOULDER bind off 3 sts. after Rows 278, 280, 282; 4 sts. after Rows 284, 286, 288, 290, 292.

ON CAM BOX SIDE, bind off 3 sts. after Rows 194, 195, 196, 197, 198, 199; 2 sts. after Rows 200, 201, 202, 203; 1 st. after Rows 204, 205, 206, 207, 208, 209, 210, 211, then knit to Row 248, bind off the center 20 sts., put the needles on the left side into holding position and complete the right half first.

Work the front section the same as the back section to ROW 168, then work Short Rows for the Bust Darts. ON OPPOSITE SIDE of CAM BOX put into holding position 8 needles after Rows 168, 169, 170, 171, 172, 173, 174, 175. ON OPPOSITE SIDE of CAM BOX bring all needles back into working position after Row 176, 177, then knit to Row 194.

ON CAM BOX SIDE, bind off 5 sts. after Rows 230, 231; 3 sts. after Rows 232, 233, 234, 235; 2 sts. after Rows 236, 237, 238, 239, 240, 241, 242, 243; 1 st. after Rows 244, 245, 246, 247; 2 sts. after Rows 248, 249; 1 st. after Rows 250, 251, 252, 253; 2 sts. after Rows 254, 255; 1 st. after Rows 256, 257, 258, 259; 2 sts. after Rows 260, 261; 1 st. after Rows 262, 263, 264, 265; 2 sts. after Rows 266, 267; 1 st. after Rows 268, 269, 270, 271; 2 sts. after Rows 272, 273; 1 st. after Rows 274, 275, 276, 277; 2 sts. after Rows 278, 279; 1 st. after Rows 280, 281, 282, 283; 2 sts. after Rows 284, 285, 286, 287, 288, 289, 290, 291; 3 sts. after Rows 292, 293, 294, 295, 296, 297; 12 sts. after Row 298.

ON EACH SIDE, increase 1 st. after Rows 44, 52, 60, 68, 76, 84, 92, 100, 108, 116, 124, 132, 140, 148, 156, 164, 172, 180, 188, 194, 200, 206, 212, 218, 224, then knit to Row 230.

ROWS 0 to 44: Knit even, then change to stockinette st.

Cast on 86 sts. with color 1 and work K1, P1, Ribbing.

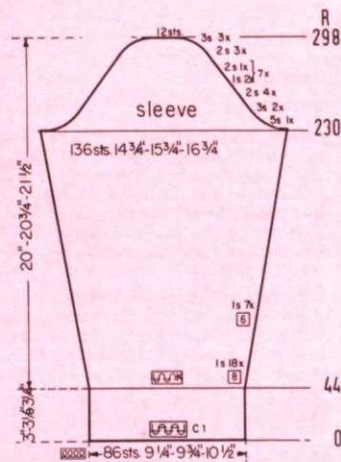

Decrease 2 sts. for EACH DART after Rows in (). ON EACH SIDE, decrease 1 st. after Rows 192, 200, 208, (208), 216, (218), 224, (228), 232, (238), 240, 248, (248), then knit to Row 274 and bind off the remaining 115 sts.

Work the front section the same as the back section to ROW 192.

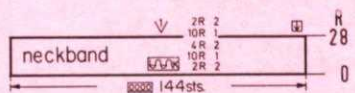

Cast on 144 sts. with color 2, work stockinette st. and the color stripes as marked in the Diagram. After Row 28 bind off all sts.

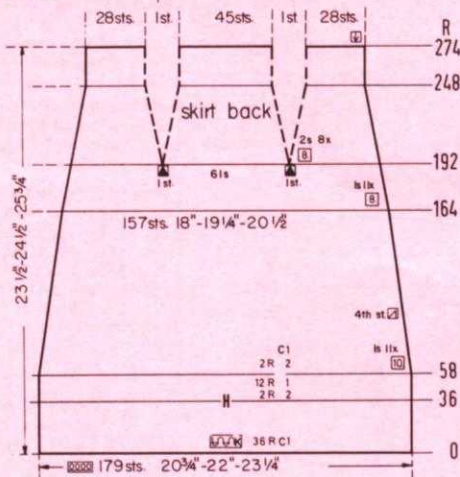

Move the Cam Box to the left side, place the sts. from the stitch holder back onto the machine, cast on 25 sts. on the right side for the under-lap and the facing and complete the left half. Follow the instructions from*. Omit the buttonholes.

ON CAM BOX SIDE, bind off 26 sts. after Row 243; 3 sts. after Rows 245, 247; 2 sts. after Rows 249, 251, 253; 1 st. after Rows 255, 257, 259, 261, 265, 269, 273. For SHOULDER bind off 3 sts. after Rows 278, 280, 282; 4 sts. after Rows 284, 286, 288, 290, 292, 294, 296.

ON CAM BOX SIDE, bind off 4 sts. after Rows 190, 192; 3 sts. after Rows 194, 196, 198; 2 sts. after Rows 200, 202, 204; 1 st. after Rows 206, 208, 210. The Armhole Shaping is now completed. Make buttonholes after Rows 212, 234, then knit to Row 243.

Make buttonholes over the 2nd-7th and 20th-25th sts. counting from the left side after Rows in (). ON CAM BOX SIDE, increase 1 st. after Rows 140, (146), 152, then knit to Row 153 and work Short Rows for the DART. ON OPPOSITE SIDE of CAM BOX put into holding position 4 needles after Rows 153, 155, 157, 159, 161, 163, 165, 167, (168), 169. After Row 171 bring all needles back into working position, knit to Row 190, make buttonholes, but do not knit.

*ROWS 133 to 140: Knit even.

ON EACH SIDE, increase 1 st. after Rows 80, 92, 104, 116, 128, then knit to Row 132, put 81 sts. on the left side onto a stitch holder. With a separate length of yarn, cast on 13 sts. on the left side for the facing. (Work over 106 needles).

ROWS 37 to 80: Knit even.

ROWS 0 to 36: Knit even, then form the hem.

Cast on 164 sts. and work stockinette st.

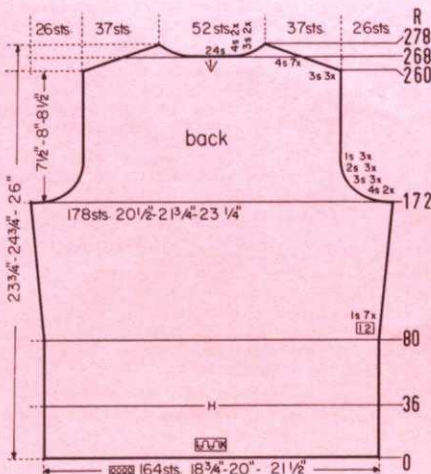

Move the Cam Box to the left side, turn the Row Counter back to 268 and complete the left half. Follow the instructions from*.

*ON CAM BOX SIDE, bind off 4 sts. after Rows 268 (EVEN ROWS = SHOULDER SHAPING); 269 (ODD ROWS = NECK SHAPING); 270, 271, 272; 3 sts. after Row 273; 4 sts. after Row 274; 3 sts. after Row 275; 4 sts. after Rows 276, 278.

ON CAM BOX SIDE, bind off 3 sts. after Rows 260, 261, 262, 263, 264, 265; 4 sts. after Rows 266, 267, then knit to Row 268, bind off the center 24 sts., put the needles on the left side into holding position and complete the right half first.

ON CAM BOX SIDE, bind off 4 sts. after Rows 172, 173, 174, 175; 3 sts. after Rows 176, 177, 178, 179, 180, 181; 2 sts. after Rows 182, 183, 184, 185, 186, 187; 1 st. after Rows 188, 189, 190, 191, 192, 193, then knit to Row 260.

ON EACH SIDE, increase 1 st. after Rows 80, 92, 104, 116, 128, 140, 152, then knit to Row 172.

ROWS 37 to 80: Knit even.

ROWS 0 to 36: Knit even, then form the hem.

Cast on 164 sts. and work stockinette st.

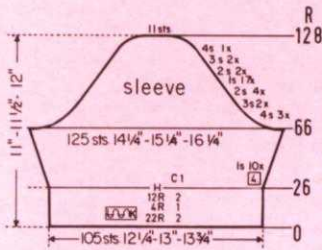

ON CAM BOX SIDE, bind off 4 sts. after Rows 66, 67, 68, 69, 70, 71; 3 sts. after Rows 72, 73, 74, 75; 2 sts. after Rows 76, 77, 78, 79, 80, 81, 82, 83. ON EACH SIDE, hang the 1st st. onto the 2nd st. after Rows 84, 86, 88, 90, 92, 94, 96, 98, 100, 102, 104, 106, 108, 110, 112, 114, 116. ON CAM BOX SIDE, bind off 2 sts. after Rows 118, 119, 120, 121; 3 sts. after Rows 122, 123, 124, 125; 4 sts. after Rows 126, 127; 11 sts. after Row 128.

ON EACH SIDE, increase 1 st. after Rows 26, 30, 34, 38 (continue with color 1 after Row 38), 42, 46, 50, 54, 58, 62, then knit to Row 66.

ROWS 0 to 26: Knit even, then form the hem.

Cast on 105 sts. with color 2, work stockinette st. and the color stripes as marked in the Diagram.

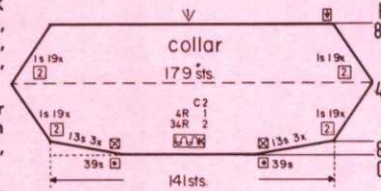

Cast on 141 sts. with color 2, work stockinette st., the color stripes as marked in the Diagram and Short Rows. ON OPPOSITE SIDE of CAM BOX put into holding position 39 needles after Rows 0, 1. ON OPPOSITE SIDE of CAM BOX bring back into working position 13 needles after Rows 2, 3, 4, 5, 6, 7. ON EACH SIDE, increase 1 st. after Rows 10, 12, 14, 16, 18, 20, 22, 24, 26, 28, 30, 32, 34, 36, 38 (continue with color 2 after Row 38), 40, 42, 44, 46. ON EACH SIDE, decrease 1 st. after Rows 50, 52, 54, 56, 58, 60, 62, 64, 66, 68, 70, 72, 74, 76, 78, 80, 82, 84, 86. After Row 88 bind off all 141 sts.

DP8178

SIZE:	10 (Bust 32"-33")	12 (Bust 34"-35")	16 (Bust 37"-38")
YARN:	Subita Crepe 2 x 3	Beatrice Crepe	Crocus Crepe
50 gr. BALLS:	4 color 1 3 color 2	5 color 1 3 color 2	6 color 1 4 color 2
TENSION:	4 to 6	5 to 7	6 to 8
GAUGE:	2" Pat: 18 sts. 22 rows Ribbing: 18 sts. 27 rows	17 sts. 21 rows sts. 26 rows	16 sts. 20 rows 16 sts. 25 rows

The instructions are the same for all sizes. PATTERN: Norwegian Design according to the Line Drawing. Use the Adjustable Needle Selector. In the instructions, each row in the Norwegian Design is counted as 1 row, but several movements of the Cam Box are needed to complete 1 row. LOWER EDGE: K1, P1, Ribbing. BANDS: Stockinette St. INCREASES: Place the end st. from the row below onto the next empty needle.

FINISHING: Block all sections. Join front and back section at sides and shoulders. Join the neckband sections. Sew the short ends of the armhole bands together. Sew 1 edge of the neckband to inside and 1 edge to outside of neckline. Sew the armhole bands to the armholes in the same manner.

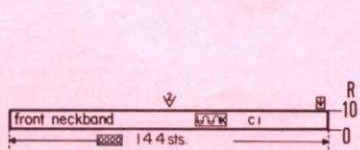

Cast on 144 sts. with color 1 and work 10 rows stockinette st., then bind off all sts.

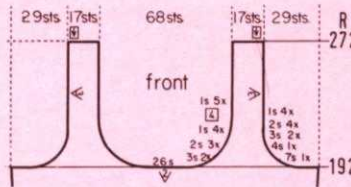

Bring the needles on the left side into working position, knit 1 row in PATTERN to the left side, turn the Row Counter back to 192 and complete the left half. Follow the instructions from*.

*ON CAM BOX SIDE, bind off 7 sts. after Row 192 (EVEN ROWS = ARM-HOLE SHAPING); 3 sts. after Row 193 (ODD ROWS = NECK SHAPING); 4 sts. after Row 194; 3 sts. after Rows 195, 196; 2 sts. after Row 197; 3 sts. after Row 198; 2 sts. after Rows 199, 200, 201, 202; 1 st. after Row 203; 2 sts. after Row 204; 1 st. after Row 205; 2 sts. after Row 206; 1 st. after Rows 207, 208, 209, 210, 211, 212, 214, 215, 219, 223, 227. After Row 272 bind off the 17 Shoulder sts.

Work the front section the same as the back section to ROW 192, then bind off the center 26 sts., put the needles on the left side into holding position and complete the right half first.

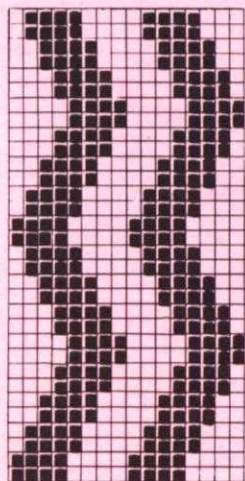

■ COLOR 2
□ COLOR 1

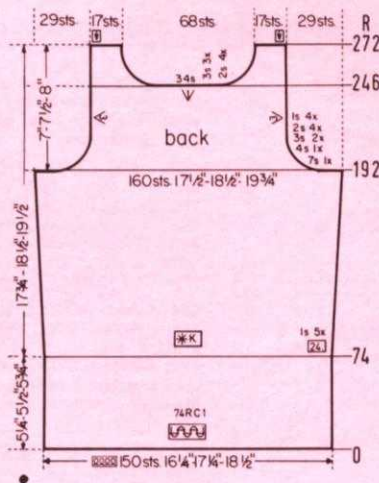

Bring the needles on the left side into working position, knit 1 row in PATTERN to the left side, turn the Row Counter back to 246 and complete the left half. Follow the instructions from*.

*ON CAM BOX SIDE, bind off 3 sts. after Rows 247, 249, 251; 2 sts. after Rows 253, 255, 257, 259. After Row 272 bind off the 17 Shoulder sts.

ON CAM BOX SIDE, bind off 7 sts. after Rows 192, 193; 4 sts. after Rows 194, 195; 3 sts. after Rows 196, 197, 198, 199; 2 sts. after Rows 200, 201, 202, 203, 204, 205, 206, 207; 1 st. after Rows 208, 209, 210, 211, 212, 213, 214, 215, then knit to Row 246, bind off the center 34 sts., put the needles on the left side into holding position and complete the right half first.

ON EACH SIDE, increase 1 st. after Rows 74, 98, 112, 146, 170, then knit to Row 192. (Work the Front Section the same to ROW 192).

ROWS 0 to 74: Knit even, then change to stockinette st. and work the Norwegian Design.

Cast on 150 sts. with color 1 and work K1, P1, Ribbing.



Cast on 66 sts. with color 1 and work 10 rows stockinette st., then bind off all sts.

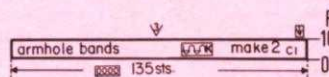

Cast on 135 sts. with color 1 and work 10 rows stockinette st., then bind off all sts.

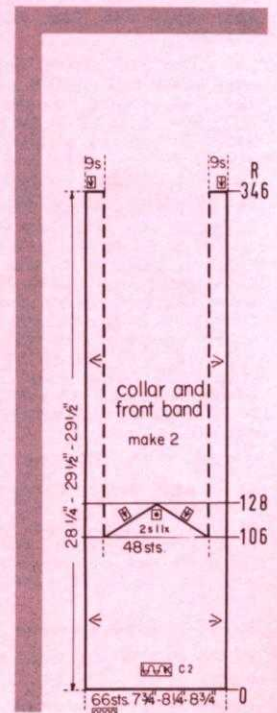

DP8176

SIZE:	8 (Bust 31")	10 (Bust 32"-33")	14 (Bust 35"-36")
YARN:	Beatrice Crepe	Allegro Dralon	Mohana
50 gr. BALLS:	5	5	7
TENSION:	5 to 7	6 to 8	6 to 8
GAUGE:	2" Stock: 16 sts. 22 rows Ribbing: 16 sts. 25 rows	15 sts. 21 rows 15 sts. 24 rows	14 sts. 21 rows 14 sts. 24 rows



The instructions are the same for all sizes. PATTERN: Stockinette Stitch. EDGES: K1, P1, Ribbing. INCREASE: Move the 2 end sts. 1 needle outward, then place the 3rd st. from the row below onto the empty needle. DECREASES: Hang the 3rd st. onto the 2nd st., then move the end sts. inward to fill the empty needle.

FINISHING: Block all sections. Join back and front sections at sides and shoulders. Sew the short ends of the armhole bands together, then sew 1 edge of the bands to inside and 1 edge to the outside of the armhole edges. Join the front band and the neckband sections, then sew 1 edge of the band to inside and 1 edge to the outside of the front edges and neckline, leaving 4 spaces of about 5/8" for the buttonholes. Begin the first buttonhole space about 3/4" from the lower edge, the following spaces are about 3/4" apart. (See picture). Finish the buttonholes, sew on buttons. Sew snaps in place to hold the underlap.

Move the Cam Box to the left side, turn the Row Counter back to 220 and complete the left half. Follow the instructions from*.

*ON CAM BOX SIDE, bind off 3 sts. after Rows 221, 223; 2 sts. after Rows 225, 227; 1 st. after Rows 229, 231, 233. After Row 236 bind off the 15 Shoulder sts.

ON CAM BOX SIDE, bind off 4 sts. after Rows 148, 149, 150, 151; 3 sts. after Rows 152, 153, 154, 155; 2 sts. after Rows 156, 157, 158, 159; 1 st. after Rows 160, 161, 162, 163, 164, 165, 166, 167, 170, 171, 174, 175, then knit to Row 220, bind off the center 31 sts., put the needles on the left side into holding position and complete the right half first.

ON EACH SIDE, increase 1 st. after Rows 72, 92, 112, 132, then knit to Row 148.

ROWS 0 to 72: Knit even, then change to stockinette st.

Cast on 127 sts. and work K1, P1, Ribbing.

Cast on 165 sts. and work 20 rows K1, P1, Ribbing, then bind off all sts.

Cast on 195 sts. and work 20 rows K1, P1, Ribbing, then bind off all sts.

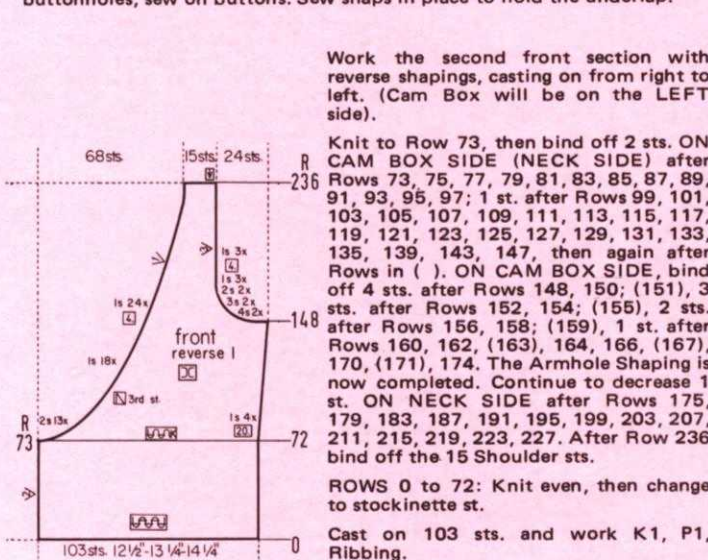

Work the second front section with reverse shapings, casting on from right to left. (Cam Box will be on the LEFT side).

Knit to Row 73, then bind off 2 sts. ON CAM BOX SIDE (NECK SIDE) after Rows 73, 75, 77, 79, 81, 83, 85, 87, 89, 91, 93, 95, 97; 1 st. after Rows 99, 101, 103, 105, 107, 109, 111, 113, 115, 117, 119, 121, 123, 125, 127, 129, 131, 133, 135, 139, 143, 147, then again after Rows in (). ON CAM BOX SIDE, bind off 4 sts. after Rows 148, 150; (151), 3 sts. after Rows 152, 154; (155), 2 sts. after Rows 156, 158; (159), 1 st. after Rows 160, 162, (163), 164, 166, (167), 170, (171), 174. The Armhole Shaping is now completed. Continue to decrease 1 st. ON NECK SIDE after Rows 175, 179, 183, 187, 191, 195, 199, 203, 207, 211, 215, 219, 223, 227. After Row 236 bind off the 15 Shoulder sts.

ROWS 0 to 72: Knit even, then change to stockinette st.

Cast on 103 sts. and work K1, P1, Ribbing.

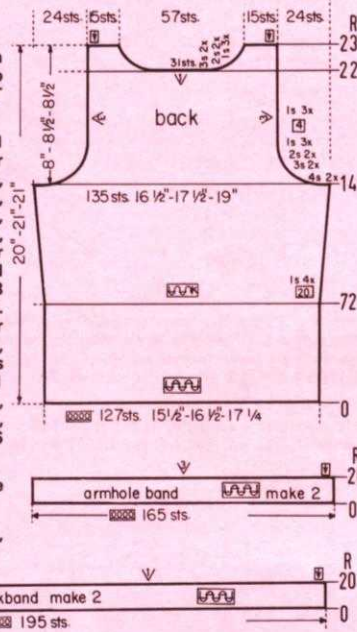

DP8182

SIZE:	18 (Bust 39"-40")	20 (Bust 41"-42")	22 (Bust 44"-45")
YARN:	Beatrice Crepe	Regia	Amore
50 gr. BALLS:	6 color 1 4 color 2	5 color 1 3 color 2	6 color 1 4 color 2
TENSION:	3 to 5	5 to 7	7 to 9
GAUGE:	2" 17 sts. 24 rows	16 sts. 23 rows	15 sts. 23 rows
ALL SIZES:	16" Jacket Type Zipper		

The instructions are the same for all sizes. PATTERN: Stockinette Stitch. INCREASES: Move the 2 end sts. 1 needle outward, then place the 3rd st. from the row below onto the empty needle. DECREASES: Hang the 3rd st. onto the 2nd st., then move the end sts. inward to fill the empty needle. To form the hem, hang the cast-on sts. back onto the machine behind the latches, then knit the following row with 1 or 2 tension settings higher.

FINISHING: Block all sections. Join the back and front sections at sides and shoulders. Sew the sleeves together and set in. Weave the open sts. of the collar together and sew the shaped edges together. Sew 1 edge of the collar and bands to the inside and 1 edge to the outside of the neckline and the front edges. Sew the zipper in place.

ROWS 106 to 346: Knit even, then bind off all 18 sts. Work the second collar section the same.

ON OPPOSITE SIDE of CAM BOX put into holding position 2 needles after Rows 106, 107, 108, 109, 110, 111, 112, 113, 114, 115, 116, 117, 118, 119, 120, 121, 122, 123, 124, 125, 126, 127. After Row 128 bring all needles back into working position, then bind off these sts. Now hang the 18 sts. held on contrast yarn back onto the machine and turn the Row Counter back to 106.

ROWS 0 to 106: Knit even, then take off 9 sts. ON EACH SIDE and work Short Rows over the remaining 48 sts.

Cast on 66 sts. with color 2 and work stockinette st.

Before working the collar, see practical knitting hint in the news letter.

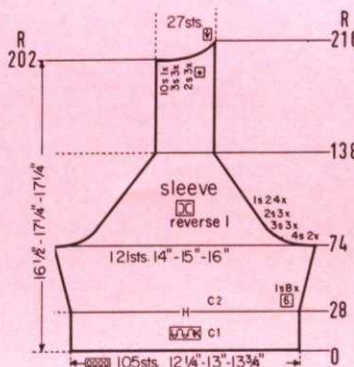

Work the second sleeve with reverse shapings, casting on from right to left. (Cam Box will be on the LEFT side at Row 0).

ON CAM BOX SIDE, bind off 4 sts. after Rows 74, 75, 76, 77; 3 sts. after Rows 78, 79, 80, 81, 82, 83; 2 sts. after Rows 84, 85, 86, 87, 88, 89. ON EACH SIDE, decrease 1 st. after Rows 90, 92, 94, 96, 98, 100, 102, 104, 106, 108, 110, 112, 114, 116, 118, 120, 122, 124, 126, 128, 130, 132, 134, 146, then knit to Row 202 and work Short Rows. ON OPPOSITE SIDE of CAM BOX put into holding position 10 needles after Row 202; 3 needles after Rows 204, 206, 208; 2 needles after Rows 210, 212, 214. After Row 216 bring all needles back into working position, then bind off all 27 sts.

ON EACH SIDE, increase 1 st. after Rows 28, 34, 40, 46, 52, 58, 64, 70, then knit to Row 74.

ROWS 0 to 28: Knit even, then form the hem and work with color 2.

Cast on 105 sts. with color 1 and work stockinette st.

Continued on page 16

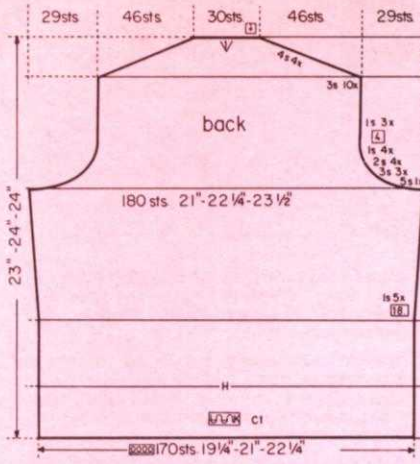

ON CAM BOX SIDE, bind off 3 sts. after Rows 252, 253, 254, 255, 256, 257, 258, 259, 260, 261, 262, 263, 264, 265, 266, 267, 268, 269, 270, 271; 4 sts. after Rows 272, 273, 274, 275, 276, 277, 278, 279. After Row 280 bind off the 30 Neck sts.

ON CAM BOX SIDE, bind off 5 sts. after Rows 174, 175; 3 sts. after Rows 176, 177, 178, 179, 180, 181; 2 sts. after Rows 182, 183, 184, 185, 186, 187, 188, 189. ON EACH SIDE, decrease 1 st. after Rows 190, 192, 194, 196, 198, 202, 206, then knit to Row 252.

ON EACH SIDE, increase 1 st. after Rows 82, 100, 118, 136, 154, then knit to Row 174.

ROWS 37 to 82: Knit even.

ROWS 0 to 36: Knit even, then form the hem.

Cast on 170 sts. with color 1 and work stockinette st.

HP3696

SIZE:	34 (Chest 34"-35")	38 (Chest 37"-38")
YARN:	Allegro Dralon	Dolly Dralon
50 gr. BALLS:	4 color 1 2 color 2	5 color 1 3 color 2
TENSION:	6 to 8	8 to 10
GAUGE:	2" 14 sts. 22 rows	13 sts. 21 rows

The instructions are the same for both sizes. PATTERN: Norwegian Design according to the Line Drawing. Use the adjustable needle selector. In the instructions, each row in the Norwegian Design is counted as 1 row, but several movements of the Cam Box are needed to complete 1 row. EDGES: K1, P1, Ribbing. To increase, place the end st. from the row below onto the next empty needle.

FINISHING: Block the sections. Join front and back section at sides and shoulders. Join the short ends of the armhole bands and the short ends of the neckband, then sew the bands in place.

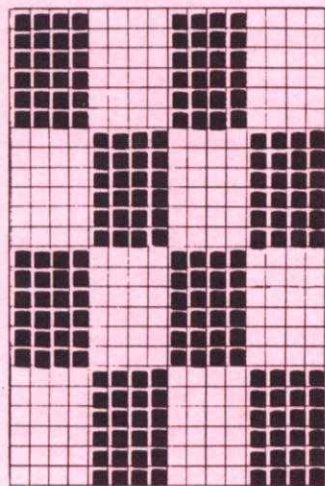

Color 1 Color 2

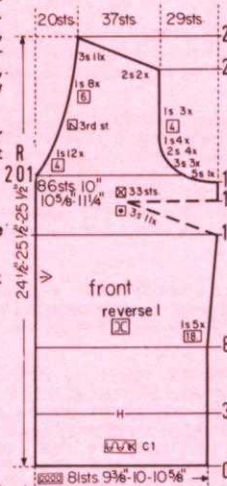

Work the second front section with reverse shapings, casting on from right to left. (Cam Box will be on the LEFT side at Row 0).

Decrease 1 st. ON NECK SIDE after Rows in (). ON CAM BOX SIDE, bind off 5 sts. after Row 196; 3 sts. after Rows 198, 200, (201), 202; 2 sts. after Rows 204, (205), 206, 208, (209), 210; 1 st. after Rows 212, (213), 214, 216, (217), 218, 220, (221), 224, (225), 228, (229). The Armhole Shaping is now completed. Continue to decrease 1 st. ON NECK SIDE after Rows 233, 237, 241, 245, 249, 255, 261, 267, 273, then again after Rows in (). For SHOULDER bind off 2 sts. after Rows 274, 276; 3 sts. after Rows 278, (279), 280, 282, 284, (285), 286, 288, 290, (291), 292, 294, 296, 298.

ON CAM BOX SIDE, increase 1 st. after Rows 82, 100, 118, 136, 154, then knit to Row 159 and work Short Rows for the Bust Dart. ON OPPOSITE SIDE of CAM BOX put into holding position 3 needles after Rows 159, 161, 163, 165, 167, 169, 171, 173, 175, 177, 179. After Row 181 bring all needles back into working position, then knit to Row 196.

ROWS 37 to 82: Knit even.

ROWS 0 to 36: Knit even, then form the hem.

Cast on 81 sts. with color 1 and work stockinette st.

Bring the needles on the left side into working position, knit 1 row in PATTERN to the left side, turn the Row Counter back to 278 and complete the left half. Follow the instructions from*.

*ON CAM BOX SIDE, bind off 3 sts. after Rows 279, 281 (ODD ROWS = NECK SHAPING); 2 sts. after Rows 283, 285; 4 sts. after Row 286 (EVEN ROWS = SHOULDER SHAPING); 2 sts. after Row 287; 4 sts. after Rows 288, 290, 292, 294.

ON CAM BOX SIDE, bind off 6 sts. after Rows 198, 199; 3 sts. after Rows 200, 201, 202, 203; 2 sts. after Rows 204, 205, 206, 207; 1 st. after Rows 208, 209, 210, 211, 212, 213, 214, 215, then knit to Row 278, bind off the center 26 sts., put the needles on the left side into holding position and complete the right half first. (For the Front Section, knit to Row 242).

ON EACH SIDE, increase 1 st. after Rows 92, 114, 136, 158, 180, then knit to Row 198.

ROWS 49 to 92: Knit even.

ROWS 0 to 48: Knit even, then change to stockinette st. and work the Norwegian Design.

Cast on 120 sts. with color 1 and work K1, P1, Ribbing.

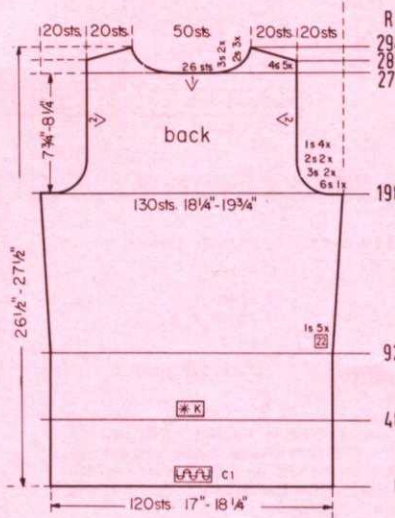

Cast on 167 sts. with color 1 and work 12 rows K1, P1, Ribbing, then bind off all sts.

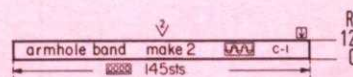

Cast on 145 sts. with color 1 and work 12 rows K1, P1, Ribbing, then bind off all sts.

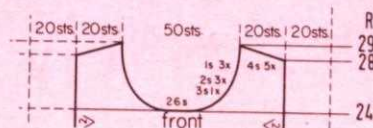

Bring the needles on the left side into working position, knit 1 row in PATTERN to the left side, turn the Row Counter back to 242 and complete the left half. Follow the instructions from*.

*ON CAM BOX SIDE, bind off 3 sts. after Row 243; 2 sts. after Rows 245, 247, 249; 1 st. after Rows 251, 253, 255. For SHOULDER, bind off 4 sts. after Rows 286, 288, 290, 292, 294.

Work the front section the same as the back section to ROW 242, then bind off the center 26 sts., put the needles on the left side into holding position and complete the right half first.

New products from KNITKING

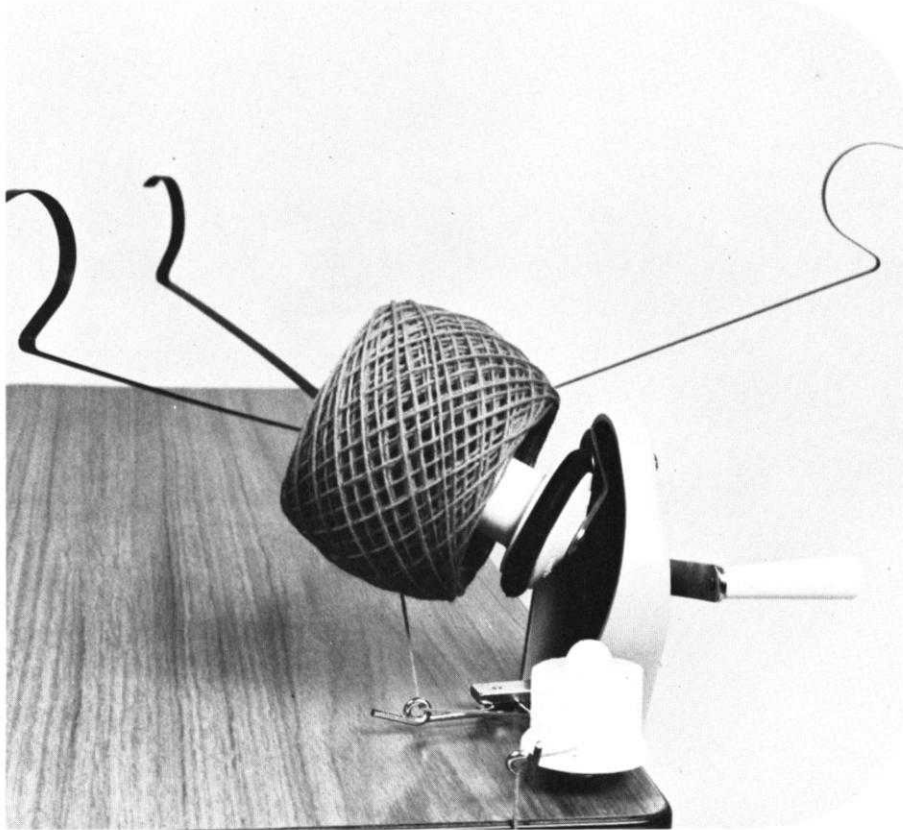

New design Yarn Winder with 'Waxamajig' and Skein Holder. As you can see from the illustration, this clever New Winder with Nylon Helical Gears winds a perfectly symmetrical ball . . . ! If you like to wax yarn (for easier knitting) you use the 'Waxamajig'. If waxing is not necessary, you bypass it . . . The Skein Holder is self adjusting. You will not find a better Hand Winder anywhere.

Complete price: \$23.95
Special Introductory Price: \$19.95
(California residents add 5% Sales Tax)
Shipping charges: \$1.75

New design electric winder

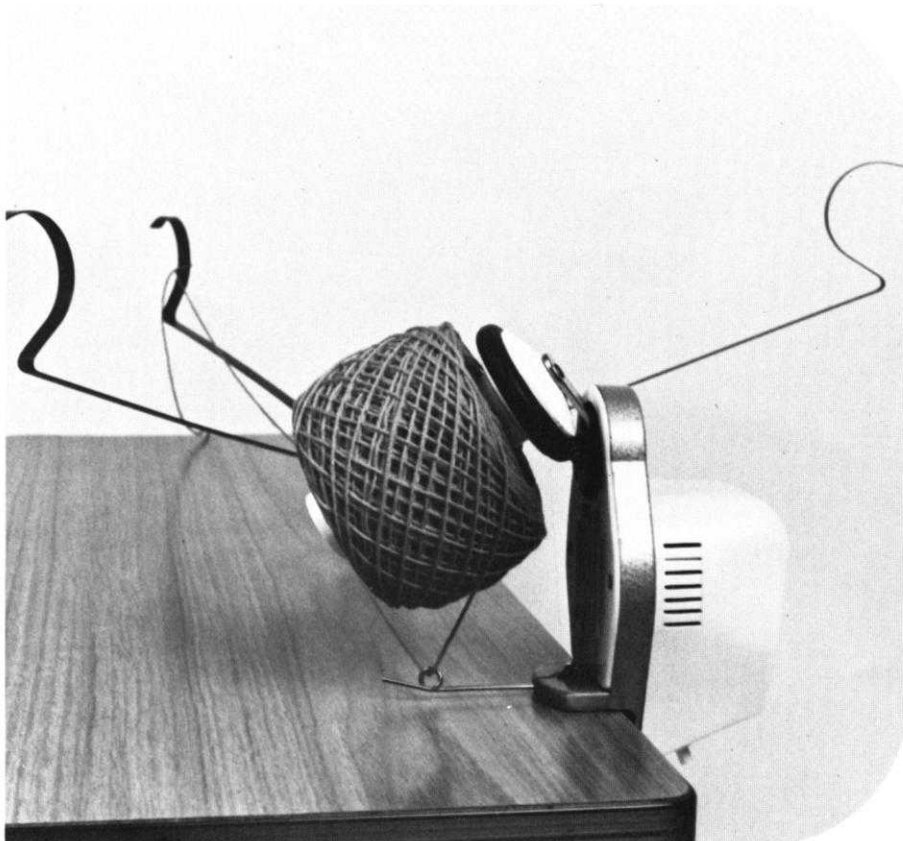

Self-contained Motorized Winder with Push Button on and off Switch . . . Special Clutch device to stop Winder if yarn bunches up or jams in the guide eye . . . Another excellent easy to use KNITKING product.

Price: Complete with Skein Holder \$44.95
Special Introductory Price: \$39.95
(California residents add 5% Sales Tax).
Shipping Charges: \$2.50

Caution Note: *The first shipment from Europe arrived wired for 220 volts, so unless you have a 220 volt outlet in your home, you should hold off purchasing until the next shipment wired for 110 volts arrives.*

Order direct from KNITKING — 1128 Crenshaw Blvd., Los Angeles, California 90019

New (ALL METAL) KNITKING TABLE

Special Designed Table for KNITKING machines only.

Sturdy All Steel construction with Tray in the rear for Tools, Books, etc., and Slots for inserting Pattern Cards.

Storage box for yarns . . . Special spot welded brackets on the back legs for storing Ribbing Attachment . . . Heavy duty Rubber Feet to prevent Table from moving around.

List Price: \$39.50

Special Introductory Price: \$34.50 (California residents add 5% Sales Tax)

Shipping - F.O.B. Los Angeles (Shipping weight approximately 25 pounds)

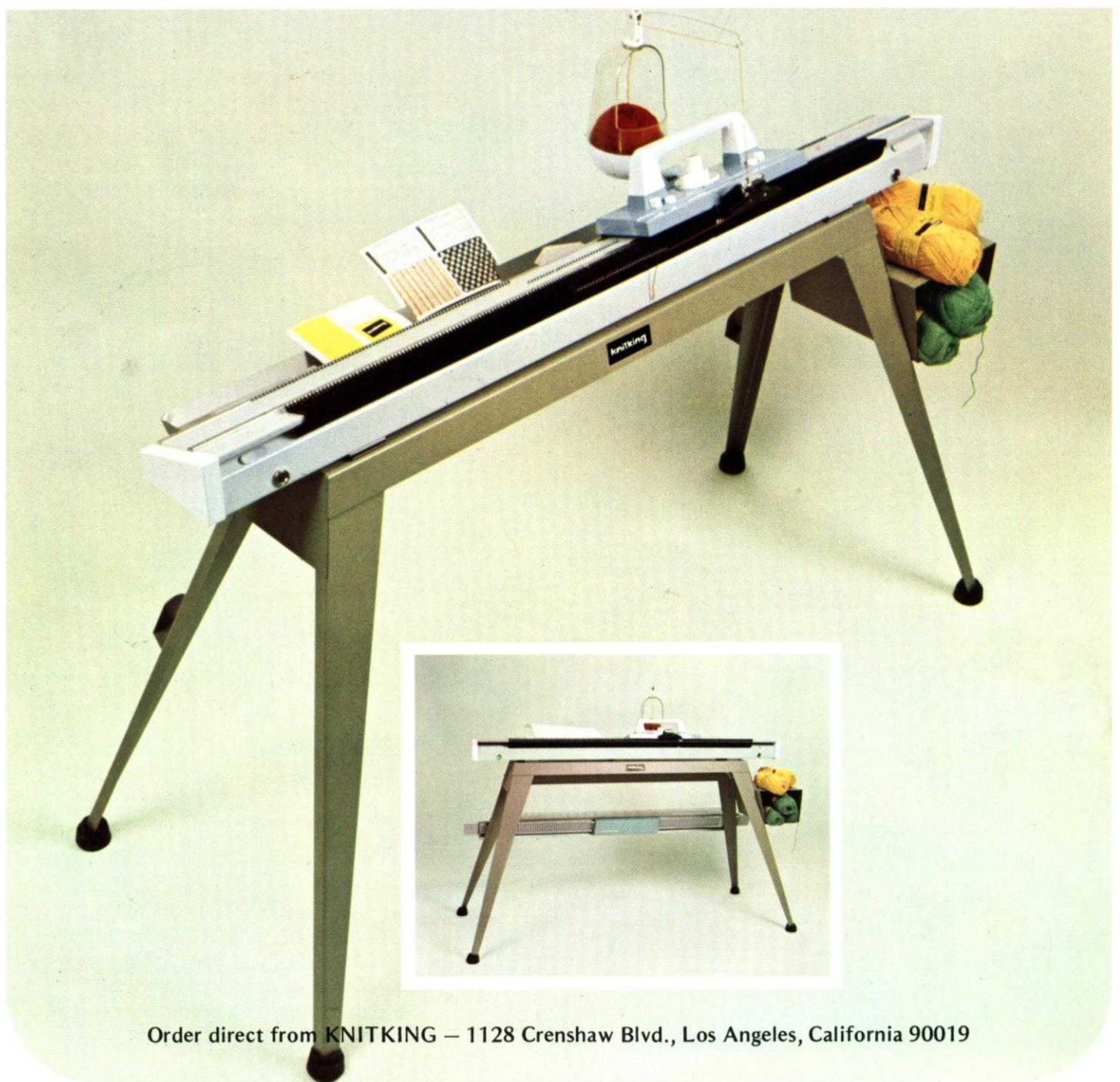

Order direct from KNITKING - 1128 Crenshaw Blvd., Los Angeles, California 90019

Another first from KNITKING

Completely Self-Contained Motorized Table for KNITKING machines (wired for 110 volts) . . . Just locate your KNITKING on the Table, no clamps or fixing necessary . . .

Simple to operate . . .

Foot and Fingertip controls.

Built in Safety Device stops machine if knitting jams . . .

Can be used with Ball or Cone Yarn.



List Price: \$349.00
Special Introductory Price: \$299.00
(California residents add 5% Sales Tax).
Freight charges — F.O.B. Los Angeles.
(Crated Table weighs approximately 100 pounds)

Order direct from KNITKING — 1128 Crenshaw Blvd., Los Angeles, California 90019

Yarn straightener

This Clever Steaming Device takes the wrinkles out of used Yarn and makes it like new again . . . The Yarn goes in one Hole, then around a Rotating Drum and out the other Hole . . . You fill the Lower Dish with water and heat it until it steams . . . It's the steam that does the straightening as you pull the Yarn through . . . You can wind by hand or directly onto your Yarn Winder.

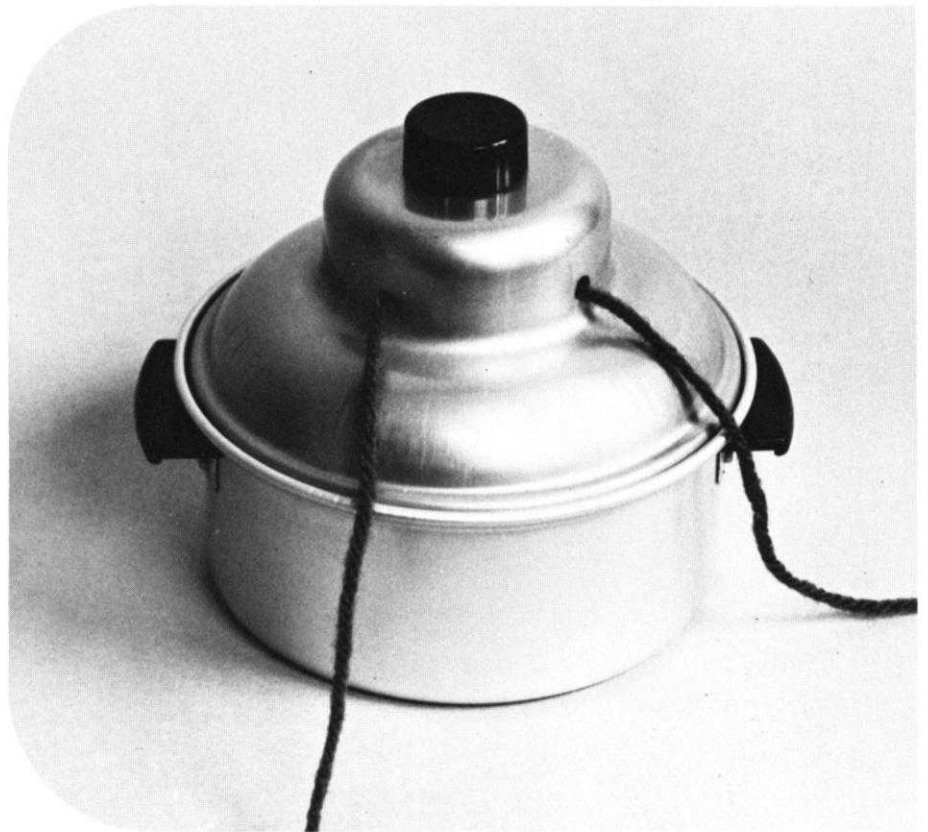

List Price: \$5.95
Special Introductory Price: \$4.95
(California residents add 5% Sales Tax)
Shipping Costs: 80¢

Carousel transfer tool set

With this Ingenious Set of 8 Transfer Tools, you can remove as few or as many stitches as you wish from your Knitter . . . The 8 Separate Units of 8 Stitch Tools are easy to handle . . . Use them instead of a contrasting color yarn to remove Knitting from your Machine . . . Use them as Transfer Tools . . . for Decreasing in the middle of rows, etc. . . . Transferring Ribbing from a double bed to a single bed, etc., etc., . suitable for all types of machines.

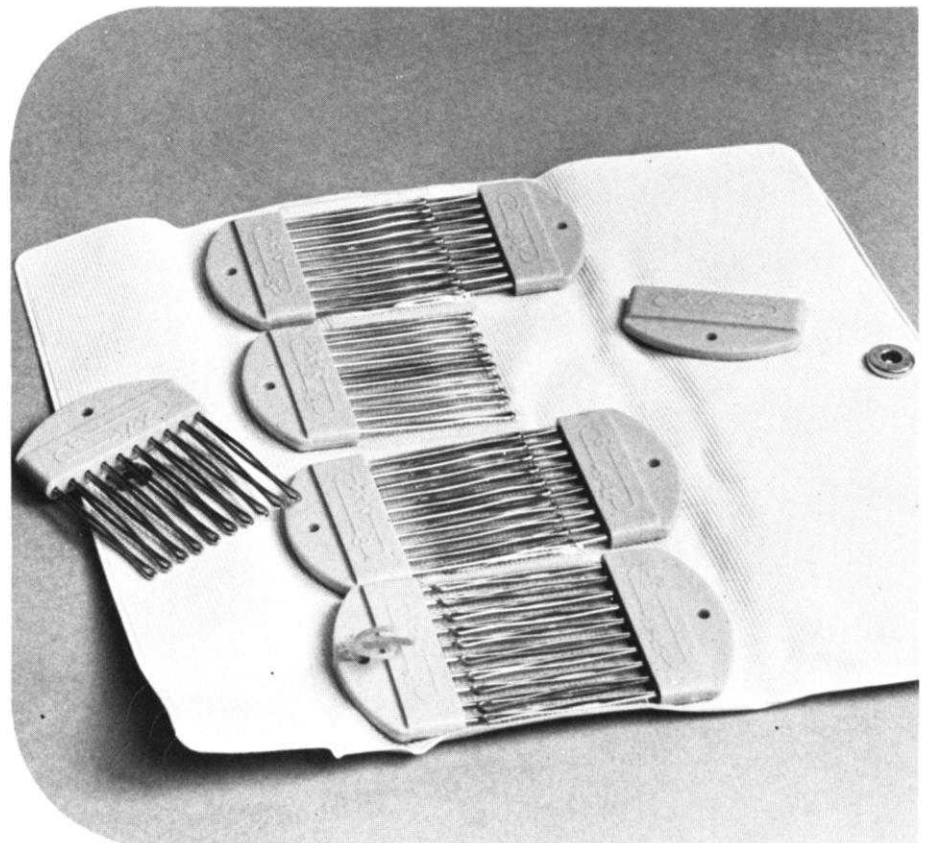

List Price: \$5.95
Introductory Price: \$4.95
(California residents add 5% Sales Tax)
Shipping Costs: 50¢

MK5421

SIZE:	8 (Chest 30"-31")	10 (Chest 32"-33")
YARN:	Allegro Dralon	Dolly Dralon
50 gr. BALLS:	4 color 1 2 color 2	5 color 1 3 color 2
TENSION:	6 to 8	8 to 10
GAUGE:	2" Pattern: 14 sts. 22 rows Ribbing: 14 sts. 24 rows	13 sts. 21 rows 13 sts. 23 rows

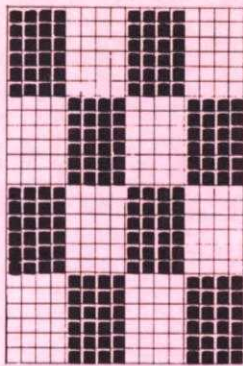

□ COLOR 1 ■ COLOR 2

The instructions are the same for both sizes. PATTERN: Stockinette Stitch and Norwegian Design according to the Line Drawing. Use the adjustable needle selector. In the instructions, each row in the Norwegian Design is counted as 1 row, but several movements of the Cam Box are needed to complete 1 row. EDGES: K1, P1, Ribbing. NECKBAND: Stockinette Stitch with color stripes as marked in the Diagram. INCREASES: Place the end st. from the row below onto the next empty needle.

FINISHING: Block all sections. Join front and back section at sides and shoulders. Sew the sleeves together and set in. Sew 1 edge of the neckband to inside and 1 edge to the outside of the neckline. Work 1 row of single crochet around the back opening, then sew in a zipper.



Cast on 103 sts. with color 2, work stockinette st. and the color stripes as marked in the Diagram. After Row 26 bind off all sts.

Bring the needles on the left side into working position, knit 1 row in PATTERN to the left side, turn the Row Counter back to 186 and complete the left half. Follow the instructions from*.

ON CAM BOX SIDE, bind off 4 sts. after Row 224 (EVEN ROWS = SHOULDER SHAPING); 12 sts. after Row 225 (ODD ROWS = NECK SHAPING); 4 sts. after Row 226; 5 sts. after Row 227; 4 sts. after Rows 228, 229, 230, 231, 232.

*ROWS 187 to 224: Knit even.

ON CAM BOX SIDE, bind off 3 sts. after Rows 150, 151; 2 sts. after Rows 152, 153, 154, 155, 156, 157; 1 st. after Rows 158, 159, 160, 161, 162, 163, then knit to Row 186, put 45 needles on the left side into holding position and complete the right half first. (For the Front Section knit to ROW 186, but do not divide the sts.)

ON EACH SIDE, increase 1 st. after Rows 48, 74, 100, 126, then knit to Row 150.

ROWS 0 to 48: Knit even, then change to stockinette st. and work the Norwegian Design.

Cast on 106 sts. with color 1 and work K1, P1, Ribbing.

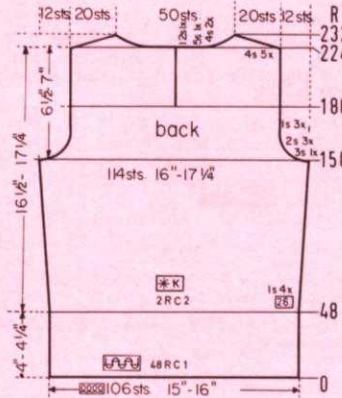

Bring the needles on the left side into working position, knit 1 row in PATTERN to the left side, turn the Row Counter back to 198 and complete the left half. Follow the instructions from*.

*ON CAM BOX SIDE, bind off 3 sts. after Row 199; 2 sts. after Rows 201, 203, 205; 1 st. after Rows 207, 209, 211, 213, 215, 217. For SHOULDER bind off 4 sts. after Rows 224, 226, 228, 230, 232.

ROWS 187 to 198: Knit even, then bind off the center 20 sts., put the needles on the left side into holding position and complete the right half first.

Work the front section the same as the back section to ROW 186.

ON CAM BOX SIDE, bind off 3 sts. after Rows 48, 49, 50, 51; 2 sts. after Rows 52, 53, 54, 55, 56, 57. ON EACH SIDE, hang the 1st st. onto the 2nd st. after Rows 58, 60, 62, 64, 66, 68, 70, 72, 74, 76, 78, 80, 82, 84, 86. ON CAM BOX SIDE, bind off 2 sts. after Rows 88, 89, 90, 91; 3 sts. after Rows 92, 93, 94, 95; 10 sts. after Row 96.

ROWS 0 to 48: Knit even, then change to stockinette st.

Cast on 84 sts. with color 1 and work K1, P1, Ribbing.

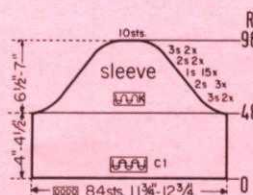
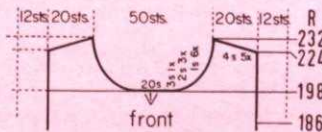

jac 40 is a must

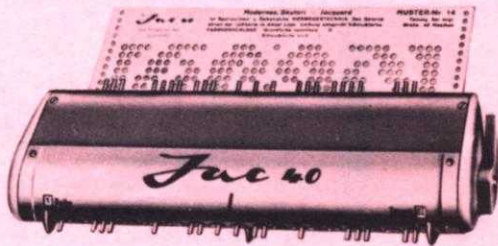

for fast easy knitting of Jaquard and Ski-sweater designs

Patterns are selected — row by row — through a pre-stamped card that is fed into the Jac.

There are over 300 cards available and illustrations of them are included with each Jac.

Jac 40's are made for most brands of machines. When ordering be sure to specify your brand of knitter as needle spacings vary. Simple to use and an essential tool for the modern knitter, Jac 40's are \$26.95 complete with 3 cards for practicing the 3 techniques, plus complete instructions.



Order from your dealer or direct from
KNITKING

1128 Crenshaw Boulevard, Los Angeles, Calif. 90019

Shipping Cost \$1.25 — California residents add 5% sales tax.

DPS180

SIZE:	16 (Bust 38"-39")	20 (Bust 41"-42")	22 (Bust 44"-45")
YARN:	Regia	Amore	Alanda
50 gr. BALLS:	Jacket: 8 color 1 1 color 2	Amore 8 color 1 1 color 2	Alanda 15 color 1 2 color 2
	Pullover: 6 color 2 1 color 1	Amore 6 color 2 1 color 1	Alanda 11 color 2 2 color 1
TENSION:	5 to 7	7 to 9	7 to 9
GAUGE:	2" 16 sts. 23 rows	15 sts. 23 rows	14 sts. 21 rows

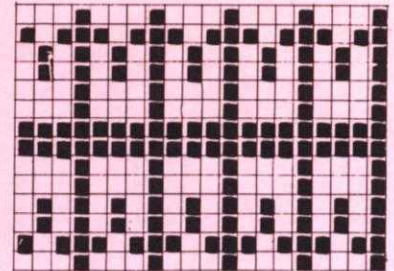

The instructions are the same for all sizes. PATTERN: Stockinette Stitch. JACKET BANDS and SLEEVE EDGES: Norwegian Design according to the Line Drawing. In the instructions, each row in the Norwegian Design is counted as 1 row, but several movements of the Cam Box are needed to complete 1 row. PULLOVER EDGES: Mock Ribbing or K1, P1, Ribbing. (See practical hint in the news letter). INCREASES: Move the 2 end sts. 1 needle outward, then place the 3rd st. from the row below onto the empty needle. DECREASES: Hang the 3rd st. onto the 2nd st., then move the end sts. inward to fill the empty needle.

FINISHING: Block all sections. PULLOVER: Join back and front section at sides and shoulders. Sew the sleeves together and set in. Sew the neckband to the neckline. Work 1 row of slip st. crochet around the back opening, then sew in a zipper. JACKET: Join the back and front sections at sides and shoulders. Sew the sleeves together and set in. Turn under 18 rows on sleeves edges and lower edge and hem to wrong side. Join the neckband to the front bands, then sew 1 edge of the band to inside and 1 edge to outside of the front edges and the neckline. (Buttonholes to the right). Finish the buttonholes, sew on buttons.

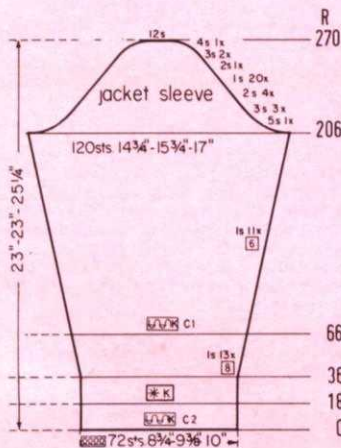

ON CAM BOX SIDE, bind off 5 sts. after Rows 206, 207; 3 sts. after Rows 208, 209, 210, 211, 212, 213; 2 sts. after Rows 214, 215, 216, 217, 218, 219, 220, 221. ON EACH SIDE, hang the 1st st. onto the 2nd st. after Rows 222, 224, 226, 228, 230, 232, 234, 236, 238, 240, 242, 244, 246, 248, 250, 252, 254, 256, 258, 260. ON CAM BOX SIDE, bind off 2 sts. after Rows 262, 263; 3 sts. after Rows 264, 265, 266, 267; 4 sts. after Rows 268, 269; 12 sts. after Row 270.

ON EACH SIDE, increase 1 st. after Rows 36, 44, 52, 60, (change to color 1 and work stockinette st. after ROW 66), 68, 76, 84, 92, 100, 108, 116, 124, 132, 140, 146, 152, 158, 164, 170, 176, 182, 188, 194, 200, then knit to Row 206.

ROWS 19 to 36: Knit even.

ROWS 0 to 18: Knit even, then work the Norwegian Design.

Cast on 72 sts. with color 2 and work stockinette st.

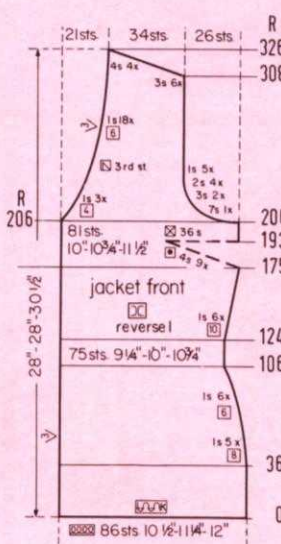

Work the second front section with reverse shapings, casting on from right to left. (Cam Box will be on the LEFT side at Row 0).

Decrease 1 st. ON OPPOSITE SIDE of CAM BOX after Rows in (). ON CAM BOX SIDE, bind off 7 sts. after Row 206; (206), 3 sts. after Rows 208, 210; (210), 2 sts. after Rows 212, 214, (214), 216, 218; (218), 1 st. after Rows 220, 222, 224, (224), 226, 228. The Armhole Shaping is now completed. Continue to decrease 1 st. ON NECK SIDE after Rows 230, 236, 242, 248, 254, 260, 266, 272, 278, 284, 290, 296, 302, then again after Rows in (). For SHOULDER bind off 3 sts. after Rows 308, (308), 310, 312, 314, (314), 316, 318; 4 sts. after Rows 320, (320), 322, 324, 326.

ON CAM BOX SIDE, increase 1 st. after Rows 124, 134, 144, 154, 164, 174, then knit to Row 175 and work Short Rows. ON OPPOSITE SIDE of CAM BOX, put into holding position 4 needles after Rows 175, 177, 179, 181, 183, 185, 187, 189, 191. After Row 193 bring all needles back into working position, then knit to Row 206.

ON CAM BOX SIDE, decrease 1 st. after Rows 36, 44, 52, 60, 68, 76, 82, 88, 94, 100, 106, then knit to Row 124.

ROWS 0 to 36: Knit even.

Cast on 86 sts. with color 1 and work stockinette st.

Move the Cam Box to the left side, turn the Row Counter back to 230 and complete the left half. Follow the instructions from*.

ON CAM BOX SIDE, bind off 3 sts. after Rows 262, 264, 266 (EVEN ROWS = SHOULDER SHAPING); 13 sts. (12 sts. for the left half) after Row 267 (ODD ROWS = NECK SHAPING); 3 sts. after Rows 268, 269, 270, 271, 272; 2 sts. after Row 273; 3 sts. after Row 274; 2 sts. after Row 275; 4 sts. after Row 276; 2 sts. after Row 277; 4 sts. after Row 278; 2 sts. after Row 279; 4 sts. after Row 280.

*ROWS 231 to 262: Knit even.

ON CAM BOX SIDE, bind off 6 sts. after Rows 166, 167; 3 sts. after Rows 168, 169, 170, 171; 2 sts. after Rows 172, 173, 174, 175, 176, 177, 178, 179; 1 st. after Rows 180, 181, 182, 183, 184, 185, 186, 187, then knit to Row 230, put 59 needles on the left side into holding position and complete the right half first.

ON EACH SIDE, increase 1 st. after Rows 64, 82, 100, 118, 134, 150, then knit to Row 166. (For the Front Section knit to ROW 152).

ROWS 29 to 64: Knit even.

K1, P1, Ribbing. Turn the Row Counter to 14. Cast on 155 sts. with color 1 and work K1, P1, Ribbing. After Row 28 (14 rows knitted) change to stockinette st. and work with color 2.

MOCK Ribbing. Cast on 78 sts. over every other needle with color 1. Knit 28 rows, then form the hem, change to color 2 and work over 155 sts.

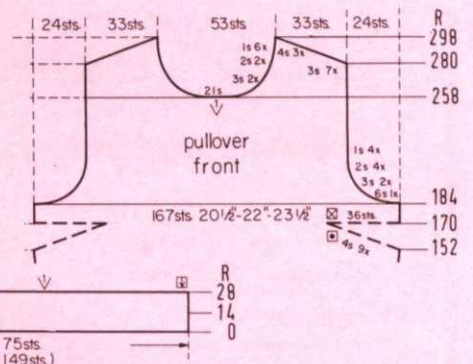
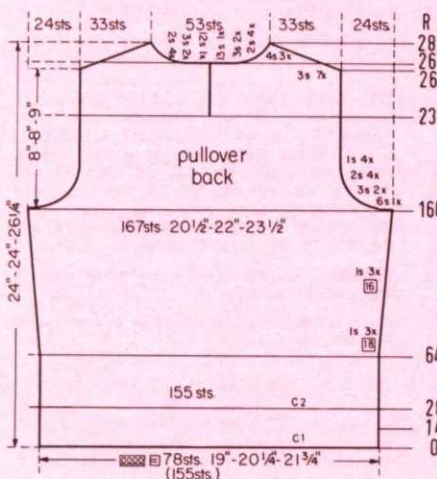

K1, P1, Ribbing. Cast on 149 sts. with color 1, work K1, P1, Ribbing. 2 rows color 1, 10 rows color 2 and 2 rows color 1. After 14 rows bind off all sts.

MOCK Ribbing. Cast on 75 sts. over every other needle with color 1 and work stockinette st. 4 rows color 1, 20 rows color 2 and 4 rows color 1. After Row 28 form the hem and bind off all sts.

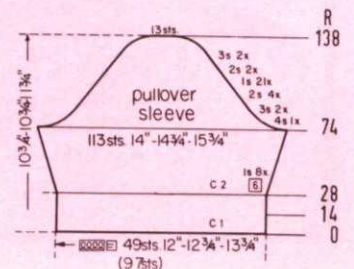

Move the Cam Box to the left side, turn the Row Counter back to 290 and complete the left half. Follow the instructions from*.

*ON CAM BOX SIDE, bind off 3 sts. after Rows 290, (EVEN ROWS = SHOULDER SHAPING); 291 (ODD ROWS = NECK SHAPING); 292, 293, 294, 295, 296; 2 sts. after Row 297; 3 sts. after Row 298; 2 sts. after Row 299; 3 sts. after Row 300; 2 sts. after Row 301; 4 sts. after Rows 302, 304, 306, 308.

ON CAM BOX SIDE, bind off 7 sts. after Rows 188, 189; 3 sts. after Rows 190, 191, 192, 193; 2 sts. after Rows 194, 195, 196, 197, 198, 199, 200, 201; 1 st. after Rows 202, 203, 204, 205, 206, 207, 208, 209, 210, 211, then knit to Row 290, bind off the center 24 sts., put the needles on the left side into holding position and complete the right half first.

ON EACH SIDE, increase 1 st. after Rows 124, 134, 144, 154, 164, 174, then knit to Row 188.

ON EACH SIDE, decrease 1 st. after Rows 36, 44, 52, 60, 68, 76, 82, 88, 94, 100, 106, then knit to Row 124.

ROWS 0 to 36: Knit even.

Cast on 184 sts. with color 1 and work stockinette st.

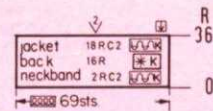

Cast on 69 sts. with color 2, work 2 rows stockinette st., then work the Norwegian Design for 16 rows. Change to color 2 and knit 18 rows stockinette st. After Row 36 bind off all sts.

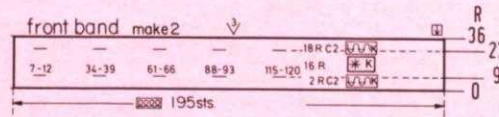
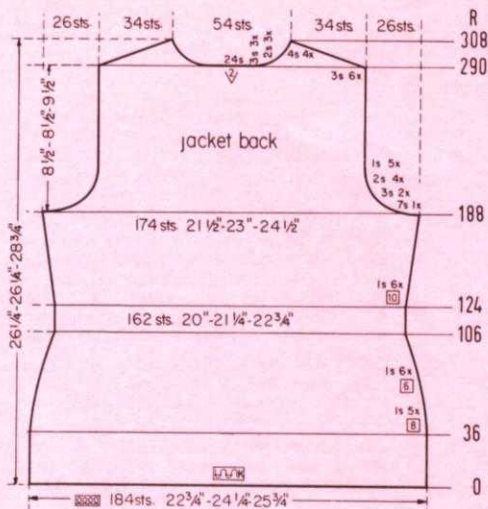

Cast on 195 sts. with color 2, work 2 rows stockinette st., then work the Norwegian Design for 16 rows. Change to color 2 and work 18 rows stockinette st. After Row 36 bind off all sts. Work the second band section the same, but make buttonholes after Rows 9 and 27 over the 7th-12th, 34th-39th, 61st-66th, 88th-93rd, 115th-120th sts. counting from the left side.

Move the Cam Box to the left side, turn the Row Counter back to 258 and complete the left half. Follow the instructions from*.

*ON CAM BOX SIDE, bind off 3 sts. after Rows 259, 261; 2 sts. after Rows 263, 265; 1 st. after Rows 267, 269, 271, 273, 275, 277. For SHOULDER bind off 3 sts. after Rows 280, 282, 284, 286, 288, 290, 292; 4 sts. after Rows 294, 296, 298.

ON CAM BOX SIDE, bind off 6 sts. after Rows 184, 185; 3 sts. after Rows 186, 187, 188, 189; 2 sts. after Rows 190, 191, 192, 193, 194, 195, 196, 197; 1 st. after Rows 198, 199, 200, 201, 202, 203, 204, 205, then knit to Row 258, bind off the center 21 sts., put the needles on the left side into holding position and complete the right half first.

Work the front section the same as the back section to ROW 152, then work Short Rows for the Bust DARTS. ON OPPOSITE SIDE of CAM BOX put into holding position 4 needles after Rows 152, 153, 154, 155, 156, 157, 158, 159, 160, 161, 162, 163, 164, 165, 166, 167, 168, 169. ON OPPOSITE SIDE of CAM BOX bring back into working position all needles after Rows 170, 171, then knit to Row 184.

ON CAM BOX SIDE, bind off 4 sts. after Rows 74, 75; 3 sts. after Rows 76, 77, 78, 79; 2 sts. after Rows 80, 81, 82, 83, 84, 85, 86, 87. ON EACH SIDE, hang the 1st st. onto the 2nd st. after Rows 88, 90, 92, 94, 96, 98, 100, 102, 104, 106, 108, 110, 112, 114, 116, 118, 120, 122, 124, 126, 128. ON CAM BOX SIDE, bind off 2 sts. after Rows 130, 131, 132, 133; 3 sts. after Rows 134, 135, 136, 137; 13 sts. after Row 138.

ON EACH SIDE, increase 1 st. after Rows 28, 34, 40, 46, 52, 58, 64, 70, then knit to Row 74.

K1, P1, Ribbing. Turn the Row Counter to 14. Cast on 97 sts. with color 1 and work K1, P1, Ribbing. After Row 28 (14 rows knitted) change to stockinette st. and work with color 2.

MOCK Ribbing. Cast on 49 sts. over every other needle with color 1. Knit 28 rows, then form the hem, change to color 2 and work over 97 sts.

DK S179

SIZE:	10 (Bust 32"-33")	12 (Bust 34"-35")	16 (Bust 37"-38")
YARN:	Beatrice Crepe	Crocus Crepe	Dolly Dralon
50 gr. BALLS:	Pants: 10 color 1 Vest: 6 color 1 4 color 2	12 color 1 7 color 1 5 color 2	12 color 1 7 color 1 5 color 2
TENSION:	5 to 7	7 to 9	8 to 10
GAUGE:	2" Stock: 16 sts. 22 rows Pattern: 15 sts. 32 rows	15 sts. 21 rows 14 sts. 30 rows	14 sts. 20 rows 13 sts. 28 rows

The instructions are the same for all sizes. PATTERN: PANTS: Stockinette Stitch; VEST: Holding Position Design according to the Line Drawing, or use JAC 40 and Pattern No. 88. The knit side is the right side. TRIM: Stockinette Stitch. DECREASES: PANTS and POCKET FLAPS: Hang the 3rd st. onto the 2nd st., then move the end sts. inward to fill the empty needles. Begin the DARTS by hanging the sts. together as marked on the Diagrams, then move the sts. together to fill the empty needles. The following decreases for the Darts lie directly above: VEST: Hang the 1st st. onto the 2nd st. INCREASES: PANTS and POCKET FLAPS: Move the 2 end sts. 1 needle outward, then place the 3rd st. from the row below onto the empty needle. VEST: Place the end st. from the row below onto the next empty needle.

FINISHING: Block all sections. PANTS: Join the front and back sections at sides. Sew the inner leg seams together. Join the sections at center back and center front. Turn under 17 rows on leg edges and 13 rows on upper edge and hem to wrong side. Insert an elastic band into the upper hem. VEST: Join the back sections at center back. Join the back and front sections at sides and shoulders. Turn under 25 rows on lower edge and hem in place. Sew the short ends of the armhole bands together, then sew 1 edge to inside and 1 edge to outside of the armhole edges. Sew the band to front edges and neckline in the same manner. (Buttonholes on the right side). Fold the belt in half and close open edges. With a button on each end, sew the belt to the back waistline. Fold the pocket flaps in half and close the open edges, then sew to vest as shown on the picture. Sew 2 buttons to each flap. Finish the buttonholes, sew on buttons.

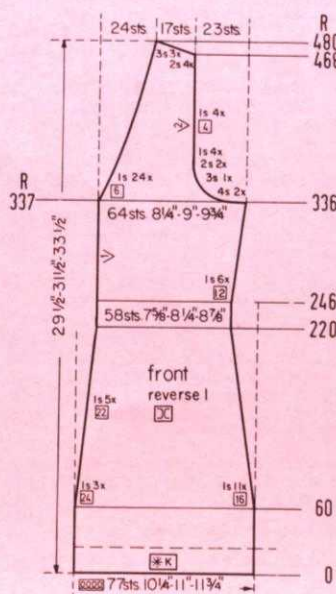

Work the second front section with reverse shapings, casting on from right to left. (Cam Box will be on the LEFT side at Row 0).

Decrease 1 st. ON NECK SIDE after Rows in (). ON CAM BOX SIDE, bind off 4 sts. after Rows 336 (337), 338; 3 sts. after Row 340; 2 sts. after Rows 342, (343), 344; 1 st. after Rows 346, 348, (349), 350, 352, 354, (355), 358, (361), 362, 366, (367). The Armhole Shaping is now completed. Continue to decrease 1 st. ON NECK SIDE after Rows 373, 379, 385, 391, 397, 403, 409, 415, 421, 427, 433, 439, 445, 451, 457, 463, then again after Rows in (). For SHOULDER bind off 2 sts. after Rows 468, (469), 470, 472, 474; (475), 3 sts. after Rows 476, 478, 480.

ON CAM BOX SIDE, increase 1 st. after Rows 246, 258, 270, 282, 294, 306, then knit to Row 336.

Decrease 1 st. ON OPPOSITE SIDE of CAM BOX after Rows in (). ON CAM BOX SIDE, decrease 1 st. after Rows 60, (60), 76, (84), 92, 108, (108), 124, (132), 140, (154), 156, 172, (176), 188, (198), 204, 220, (220), then knit to Row 246.

ROWS 0 to 60: Knit even.

Cast on 77 sts. with color 1 and work the Holding Position Design.

Continued on page 24

Work the second back section with reverse shapings, casting on from right to left. (Cam Box will be on the LEFT side at Row 0).

ON CAM BOX SIDE, bind off 10 sts. after Row 457 (ODD ROWS = NECK SHAPING); 3 sts. after Rows 459, 461; 2 sts. after Rows 463, 465, 467, 468 (EVEN ROWS = SHOULDER SHAPING); 1 st. after Row 469; 2 sts. after Row 470; 1 st. after Row 471; 2 sts. after Row 472; 1 st. after Row 473; 2 sts. after Row 474; 1 st. after Row 475; 3 sts. after Rows 476, 478, 480.

ON CAM BOX SIDE, bind off 4 sts. after Rows 336, 338; 3 sts. after Row 340; 2 sts. after Rows 342, 344; 1 st. after Rows 346, 348, 350, 352, 354, 358, 362, 366, then knit to Row 457.

Increase 1 st. ON OPPOSITE SIDE of CAM BOX after Rows in (). ON CAM BOX SIDE, increase 1 st. after Rows 246, (246), 258, 270, 282, (290), 294, 306, (334), then knit to Row 336.

Decrease 1 st. ON OPPOSITE SIDE of CAM BOX after Rows in (). ON CAM BOX SIDE, decrease 1 st. after Rows 60, (60), 76, (84), 92, 108, (108), 124, (132), 140, (154), 156, 172, (176), 188, (198), 204, 220, (220), then knit to Row 246.

ROWS 0 to 60: Knit even.

Cast on 78 sts. with color 1 and work the Holding Position Design.

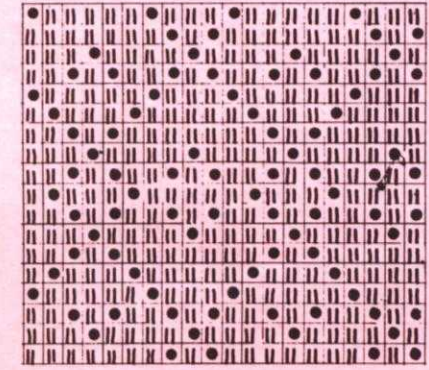
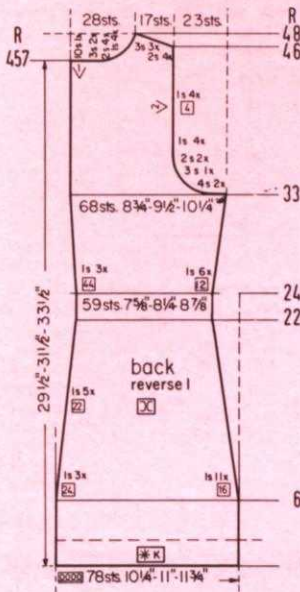

- 35-36 COLOR 2
- 33-34 COLOR 1
- 31-32 COLOR 2
- 29-30 COLOR 1
- 27-28 COLOR 2
- 25-26 COLOR 1
- 23-24 COLOR 2
- 21-22 COLOR 1
- 19-20 COLOR 2
- 17-18 COLOR 1
- 15-16 COLOR 2
- 13-14 COLOR 1
- 11-12 COLOR 2
- 9-10 COLOR 1
- 7-8 COLOR 2
- 5-6 COLOR 1
- 3-4 COLOR 2
- 1-2 COLOR 1

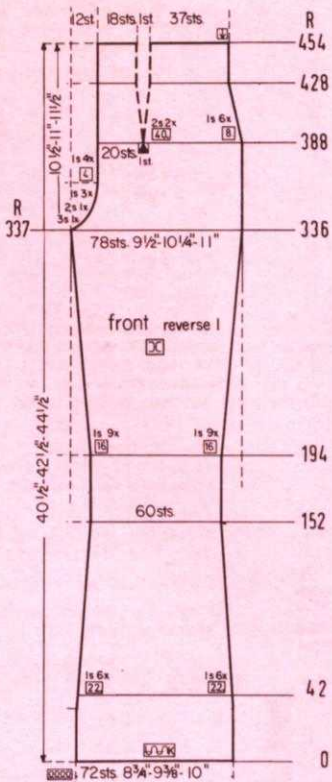

Work the second front section with reverse shapings, casting on from right to left. (Cam Box will be on the LEFT side at Row 0).

Decrease 2 sts. for the DART after Rows in (). ON CAM BOX SIDE, decrease 1 st. after Rows 388, (388), 396, 404, 412, 420, 428, (428), then knit to Row 454 and bind off the remaining 56 sts.

ON CAM BOX SIDE, bind off 3 sts. after Row 337; 2 sts. after Row 339; 1 st. after Rows 341, 343, 345, 347, 351, 355, 359, then knit to Row 388.

ON EACH SIDE, increase 1 st. after Rows 194, 210, 226, 242, 258, 274, 290, 306, 322, then knit to Row 337.

ON EACH SIDE, decrease 1 st. after Rows 42, 64, 86, 108, 130, 152, then knit to Row 194.

ROWS 0 to 42: Knit even.

Cast on 72 sts. and work stockinette st.

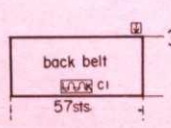

Cast on 57 sts. with color 1 and work 38 rows stockinette st., then bind off all sts.

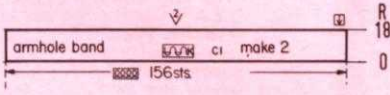

Cast on 156 sts. with color 1 and work 18 rows stockinette st., then bind off all sts.

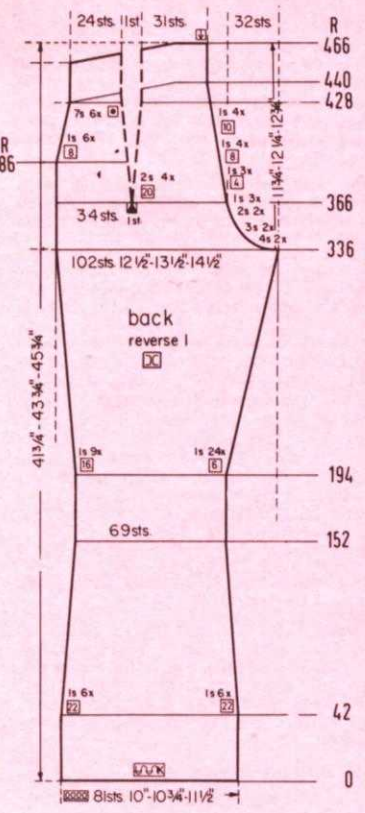

Work the second back section with reverse shapings, casting on from right to left. (Cam Box will be on the LEFT side at Row 0).

Decrease 2 sts. for the DART after (DART) and 1 st. ON OPPOSITE SIDE of CAM BOX after Rows in (). ON CAM BOX SIDE, bind off 4 sts. after Rows 336, 338; 3 sts. after Rows 340, 342; 2 sts. after Rows 344, 346; 1 st. after Rows 348, 350, 352, 354, 358, 362, 366, (DART 366), 374, 382, (DART 386), (386), 390, (394), 398, (402), (DART 406), 408, (410), 418, (418), (426), (DART 426), 428, but do not knit after the last decrease. Work Short Rows. ON OPPOSITE SIDE of CAM BOX put into holding position 7 needles after Rows 428, 430, 432, 434, 436, 438. After Row 440 bring all needles back into working position, then knit to Row 466 and bind off the remaining 56 sts.

Increase 1 st. ON OPPOSITE SIDE of CAM BOX after Rows in (). ON CAM BOX SIDE, increase 1 st. after Rows 194, (194), 200, 206, (210), 212, 218, 224, (226), 230, 236, 242, (242), 248, 254, (258), 260, 266, 272, (274), 278, 284, 290, (290), 296, 302, (306), 308, 314, 320, (322), 326, 332, then knit to Row 336.

ON EACH SIDE, decrease 1 st. after Rows 42, 64, 86, 108, 130, 152, then knit to Row 194.

ROWS 0 to 42: Knit even.

Cast on 81 sts. and work stockinette st.

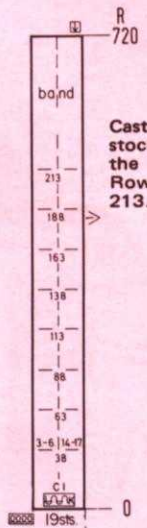

Cast on 19 sts. with color 1 and work stockinette st. Make buttonholes over the 3rd-6th and 14th-17th sts. after Rows 38, 63, 88, 113, 138, 163, 188, 213. After Row 720 bind off all sts.

Move the Cam Box to the left side, turn the Row Counter back to Row 48 and complete the left side. Follow the instructions from*.

*ON INNER EDGE, decrease 1 st. after Rows 50, 52, 54, 56, 58, 60. After Row 62 bind off the remaining 6 sts.

Move the Cam Box to the right side, turn the Row Counter to 14, cast on 21 sts. over the remaining center 21 needles and work stockinette st. over all 45 needles to Row 48, then bind off the center 21 sts., put the needles on the left side into holding position and complete the right side first.

Bring the 6 needles on the left side into working position, turn the Row Counter back to 0 and repeat ROWS 0 to 14.

ROWS 0 to 14: ON INNER EDGE, increase 1 st. after Rows 2, 4, 6, 8, 10, 12, then knit to Row 14 and put the needles into holding position.

Using 2 separate balls of color 1, cast on 6 sts. ON EACH SIDE of the center 33 needles. Put the needles on the left side into holding position and work over the sts. on the right side first.

DPS181

SIZE:	20 (Bust 42"-43")	24 (Bust 45"-46")
YARN:	Regia	Amore
50 gr. BALLS:	13	14
TENSION:	6 to 8	7 to 9
GAUGE:	2" Stock: 16 sts. 23 rows	15 sts. 23 rows
	Pattern: 15 sts. 36 rows	14 sts. 36 rows



The instructions are the same for both sizes. PATTERN: Holding Position Design using Wheel W3. The purl side is the right side. COLLAR and BAND: Stockinette Stitch, worn on the knit side. INCREASES: Place the end st. from the row below onto the next empty needle. DECREASES: Hang the 1st st. onto the 2nd st.

FINISHING: Sew the Bust Darts in place. Join back and front sections at sides and shoulders. Sew the sleeves together and set in. Turn under 18 rows on sleeve edges and lower edge and hem to wrong side. Weave the open stitches of the collar together. Join the shaped edges of the collar. Sew 1 edge of the collar and band to inside and 1 edge to outside of neckline and front edges. (Buttonholes to the right). Finish the buttonholes, sew on buttons.

Pattern Stitch

1. With Wheel W3 put the 3rd and 4th, the 7th and 8th etc. needles into holding position, knit 1 row. 2. Push in the left needle retractor, knit 1 row. 3. All needles are in working position, release the retractor button and knit 2 rows. 4. Put the 1st and 2nd, the 5th and 6th etc. needles into holding position, knit 1 row. 5. Push in the left retractor button, knit 1 row. 6. All needles are in working position, release the retractor button, knit 2 rows. Repeat from 1 to 6 for pattern.

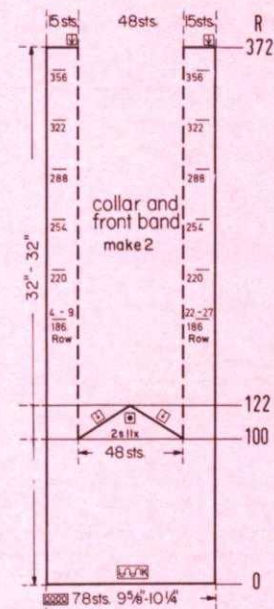

Rows 101 to 372: Make buttonholes after Rows 186, 220, 254, 288, 322, 356 over the 4th-9th and 22nd-27th sts. counting from the left side. After Row 372 bind off all sts. Work the second collar section the same, but omit the buttonholes.

ON OPPOSITE SIDE of CAM BOX put into holding position 2 needles after Rows 100, 101, 102, 103, 104, 105, 106, 107, 108, 109, 110, 111, 112, 113, 114, 115, 116, 117, 118, 119, 120, 121. After Row 122 bring all needles back into working position, then bind off these sts. Now hang the 30 sts. held on contrast yarn back onto the machine, turn the Row Counter back to 100.

ROWS 0 to 100: Knit even, then take off 15 sts. ON EACH SIDE and work Short Rows over the remaining 48 sts.

Cast on 78 sts. and work stockinette st.

Before working the collar, see practical knitting hint in the news letter.

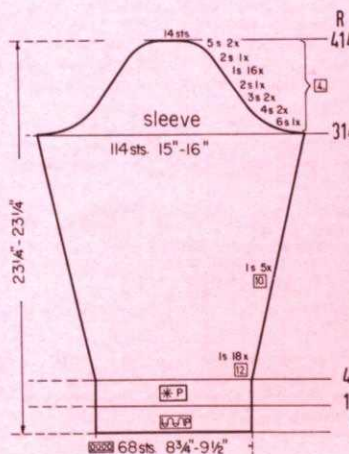

ON CAM BOX SIDE, bind off 6 sts. after Rows 314, 315; 4 sts. after Rows 318, 319, 322, 323; 3 sts. after Rows 326, 327, 330, 331; 2 sts. after Rows 334, 335. ON EACH SIDE, decrease 1 st. after Rows 338, 342, 346, 350, 354, 358, 362, 366, 370, 374, 378, 382, 386, 390, 394, 398. ON CAM BOX SIDE, bind off 2 sts. after Rows 402, 403; 5 sts. after Rows 406, 407, 410, 411; 14 sts. after Row 414.

ON EACH SIDE, increase 1 st. after Rows 48, 60, 72, 84, 96, 108, 120, 132, 144, 156, 168, 180, 192, 204, 216, 228, 240, 252, 264, 274, 284, 294, 304, then knit to Row 314.

ROWS 19 to 48: Knit even.

ROWS 0 to 18: Knit even, then work the Holding Position Design.

Cast on 68 sts. and work stockinette st.

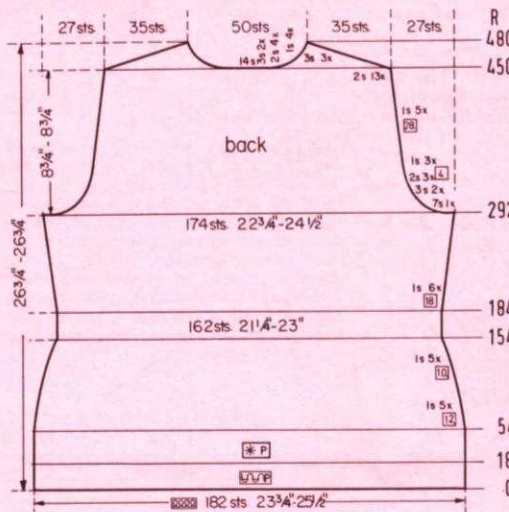

Bring the needles on the left side into working position, knit 1 row in PATTERN to the left side, turn the Row Counter back to 450 and complete the left half. Follow the instructions from*.

*ON CAM BOX SIDE, bind off 2 sts. after Row 450 (EVEN ROWS = SHOULDER SHAPING); 3 sts. after Row 451 (ODD ROWS = NECK SHAPING); 2 sts. after Row 452; 3 sts. after Row 453; 2 sts. after Rows 454, 455, 456, 457, 458, 459, 460, 461, 462; 1 st. after Row 463; 2 sts. after Row 464; 1 st. after Row 465; 2 sts. after Row 466; 1 st. after Row 467; 2 sts. after Row 468; 1 st. after Row 469; 2 sts. after Row 470, 472, 474; 3 sts. after Rows 476, 478, 480.

ON CAM BOX SIDE, bind off 7 sts. after Rows 292, 293; 3 sts. after Rows 296, 297, 300, 301; 2 sts. after Rows 304, 305, 308, 309, 312, 313. ON EACH SIDE, decrease 1 st. after Rows 316, 320, 324, 328, 356, 384, 412, 440, then knit to Row 450, bind off the center 14 sts., put the needles on the left side into holding position and complete the right half first. (While working the right half, bring the PATTERN needles back into working position manually).

ON EACH SIDE, increase 1 st. after Rows 184, 202, 220, 238, 256, 274, then knit to Row 292.

ON EACH SIDE, decrease 1 st. after Rows 54, 66, 78, 90, 102, 114, 124, 134, 144, 154, then knit to Row 184.

ROWS 19 to 54: Knit even.

ROWS 0 to 18: Knit even, then work the Holding Position Design.

Cast on 182 sts. and work stockinette st.

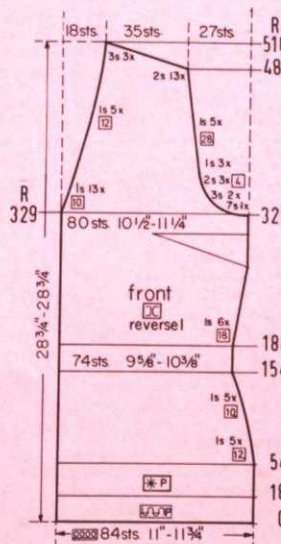

Work the second front section with reverse shapings. Cast on the regular way. After 18 rows stockinette st., knit 1 row in PATTERN to the left side, turn the Row Counter back to 18. The Cam Box will be on the LEFT side at even numbered rows.

Decrease 1 st. ON NECK SIDE after Rows in (). ON CAM BOX SIDE, bind off 7 sts. after Row 328; (329), 3 sts. after Rows 332, 336; (339), 2 sts. after Rows 340, 344, 348; (349), 1 st. after Rows 352, 356, (359), 360, 364, (369), (379), (389), 392, (399), (409), (419), 420, (429), (439), 448, (449), (459), (471), 476, (483), then knit to Row 486. Continue to decrease 1 st. ON NECK SIDE after Rows in (). For SHOULDER bind off 2 sts. after Rows 486, 488, 490, 492, 494, (495), 496, 498, 500, 502, 504, 506, (507), 508, 510; 3 sts. after Rows 512, 514, 516.

ON CAM BOX SIDE, increase 1 st. after Rows 184, 202, 220, 238, 256, 274, then knit to Row 328.

ON CAM BOX SIDE, decrease 1 st. after Rows 54, 66, 78, 90, 102, 114, 124, 134, 144, 154, then knit to Row 184.

ROWS 19 to 54: Knit even.

ROWS 0 to 18: Knit even, then work the Holding Position Design.

Cast on 84 sts. and work stockinette st.

DP 8183

SIZE:	20 (Bust 42"-43")	24 (Bust 45"-46")	44 (Bust 48"-49")
YARN:	Beatrice Crepe	Regia	Amore
50 gr. BALLS:	13	12	14
TENSION:	3 to 5	5 to 7	7 to 9
GAUGE:	2" 17 sts. 24 rows	16 sts. 23 rows	15 sts. 23 rows



The instructions are the same for all sizes. PATTERN: Stockinette Stitch and Eyelet with Cable Design on the Front Sections according to the Line Drawing. DECREASES: Sides and Center Back: Hang the 4th st. onto the 3rd st., then move the end sts. inward to fill the empty needle; Front Edge: Hang the 46th st. onto the 45th st. then move the end sts. inward to fill the empty needle. INCREASES: Move the 2 end sts. 1 needle outward, then place the 3rd st. from the row below onto the empty needle.

FINISHING: Block all sections. Weave the back sections together, 1 st. in from each edge. Join back and front sections at sides and shoulders. Sew the sleeves together and set in. Weave the open sts. of the facing together, then sew the facing to neckline. Turn under 12 sts. on the front edges and the neckline and hem to wrong side. Turn under 18 rows on lower edge and sleeve edges and hem to wrong side. Turn under 12 rows on upper edge of the pocket and hem to wrong side. Sew the pockets in place. Finish the buttonholes, sew on buttons.

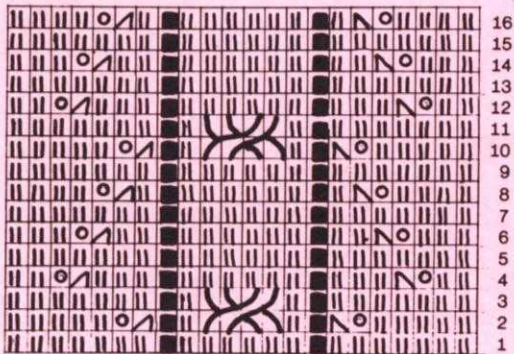

DP 8183 Line Drawing

The Pattern Stitch Border is worked over the 22 sts. marked on the Diagram. Before crossing the sts., let the 8th and 15th sts. slide off the needles, the sts. are then easier to cross. To cross the sts. use 2 double transfer tools. After the sts. have been crossed, bring the empty needles back into working position. After each 30 to 40 rows, let the 8th and 15th sts. slide off the needles, (the first time down to the cast-on) then latch the sts. up into knit sts.

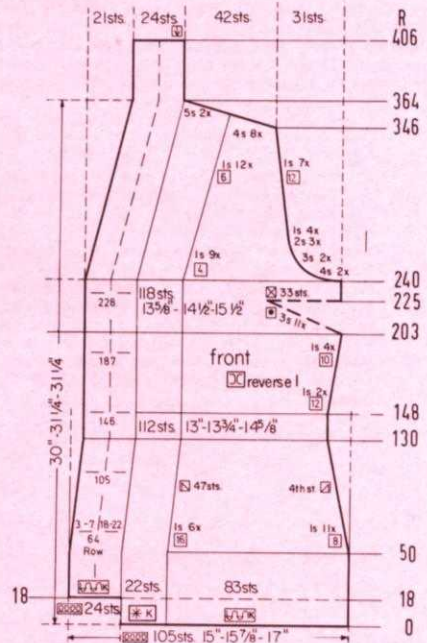

MK 5417

SIZE:	3 (Chest 22")	4 (Chest 23")	6 (Chest 24"-25")
YARN:	Beatrice Crepe	Beatrice Crepe	Allegro Dralon
50 gr. BALLS:	3 color 1 2 color 2	4 color 1 3 color 2	4 color 1 3 color 2
TENSION:	4 to 6	5 to 7	6 to 8
GAUGE:	2" 17 sts. 23 rows	16 sts. 22 rows	15 sts. 21 rows
ALL SIZES:	14" Jacket Type Zipper		

The instructions are the same for all sizes. PATTERN: Stockinette Stitch with repeated color stripes as marked in the Diagrams. DECREASES: Hang the 3rd st. onto the 2nd st., then move the end sts. inward to fill the empty needle. Begin the DARTS by hanging the sts. together as marked in the Diagram, then move the sts. together to fill the empty needles. The following decreases for the DARTS lie directly above. INCREASES: Move the 2 end sts. 1 needle outward, then place the 3rd st. from the row below onto the empty needle.

FINISHING: Block all sections. Join back and front section at sides and shoulders. Sew the sleeves together and set in. Turn under 22 rows on lower edge and 9 rows on sleeve edges and hem to wrong side. Sew the shaped edges of the collar together. Sew 1 edge of the collar and band to inside and 1 edge to outside of the front edges and neckline. Sew the zipper in place. Turn under 9 rows on straight edge of the pocket and hem to wrong side. Attach an applique to the pocket, then sew the pocket in place.



MK 5417 Sleeve

ON CAM BOX SIDE, bind off 3 sts. after Rows 44, 45, 46, 47; 2 sts. after Rows 48, 49, 50, 51. ON EACH SIDE, hang the 1st st. onto the 2nd st. after Rows 52, 54, 56, 58, 60, 62, 64, 66, 68, 70. ON CAM BOX SIDE, bind off 2 sts. after Rows 72, 73, 74, 75; 3 sts. after Rows 76, 77, 78, 79; 10 sts. after Row 80.

ON EACH SIDE, increase 1 st. after Rows 18, 22, 26, 30, 34, 38, then knit to Row 44.

ROWS 0 to 18: Knit even.

Cast on 58 sts. with color 1, work stockinette st. and the color stripes as marked in the Diagram.

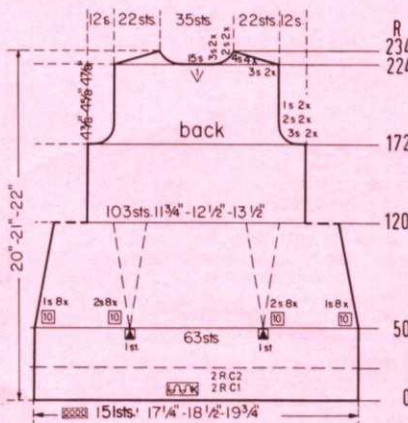

Move the Cam Box to the left side, turn the Row Counter back to 224 and complete the left half. Follow the instructions from *.

*ON CAM BOX SIDE, bind off 3 sts. after Rows 224 (EVEN ROWS = SHOULDER SHAPING), 225 (ODD ROWS = NECK SHAPING), 226, 227; 4 sts. after Row 228; 2 sts. after Row 229; 4 sts. after Row 230; 2 sts. after Row 231; 4 sts. after Rows 232, 234.

ON CAM BOX SIDE, bind off 3 sts. after Rows 172, 173, 174, 175; 2 sts. after Rows 176, 177, 178, 179; 1 st. after Rows 180, 181, 182, 183, then knit to Row 224, bind off the center 15 sts., put the needles on the left side into holding position and complete the right half first.

Decrease 2 sts. for EACH DART and 1 st. ON EACH SIDE after Rows 50, 60, 70, 80, 90, 100, 110, 120, then knit to Row 172.

ROWS 0 to 50: Knit even.

Cast on 151 sts. with color 1, work stockinette st. and the color stripes as marked in the Diagram.

Work the second front section with reverse shapings, casting on from right to left. (Cam Box will be on the LEFT side at Row 0).

Decrease 1 st. for the FRONT SHAPING after Rows in (). ON CAM BOX SIDE, bind off 4 sts. after Rows 240, (240), 242; 3 sts. after Rows 244, (244), 246; 2 sts. after Rows 248, (248), 250, 252; (252), 1 st. after Rows 254, 256, (256), 258, 260, (260), 262, (264), (268), (272), 274, (276), (282), 286, (288), (294), 298, (300), (306), 310, (312), (318), 322, (324), (330), 334, (336), (342). For SHOULDER bind off 4 sts. after Rows 346, 348, 350, 352, 354, 356, 358, 360; 5 sts. after Rows 362, 364. Work over the remaining 24 sts. (FACING) to Row 406, then put the sts. onto a stitch holder.

Continue to make buttonholes after (B.H.) ON CAM BOX SIDE, increase 1 st. after Rows 148, 160, 172, 182, (B.H. 187), 192, 202, then knit to Row 203 and work Short Rows for the Bust Dart. ON OPPOSITE SIDE of CAM BOX put into holding position 3 needles after Rows 203, 205, 207, 209, 211, 213, 215, 217, 219, 221, 223. After Row 225, bring all needles back into working position, make buttonholes after Row 228, then knit to Row 240.

ON FRONT EDGE, make buttonholes over the 3rd-7th and 18th-22nd sts. after (B.H.). Decrease 1 st. for the FRONT SHAPING after Rows in (). ON CAM BOX SIDE, decrease 1 st. after Rows 50, (50), 58, (B.H. 64), 66, (66), 74, 82, (82), 90, 98, (98), (B.H. 105), 106, 114, (114), 122, 130, (130), (B.H. 146), then knit to Row 148.

ROWS 19 to 50: Knit even.

ROWS 0 to 18: Knit even, then cast on 24 sts. ON OPPOSITE SIDE of CAM BOX. (Use a separate length of yarn).

Cast on 105 sts., work stockinette st. and the Eyelet with Cable Design over the 22 sts. marked on the Diagram.

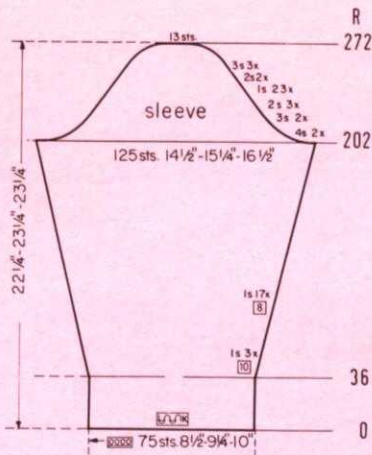

ON CAM BOX SIDE, bind off 4 sts. after Rows 202, 203, 204, 205; 3 sts. after Rows 206, 207, 208, 209; 2 sts. after Rows 210, 211, 212, 213, 214, 215. ON EACH SIDE, hang the 1st st. onto the 2nd st. after Rows 216, 218, 220, 222, 224, 226, 228, 230, 232, 234, 236, 238, 240, 242, 244, 246, 248, 250, 252, 254, 256, 258, 260. ON CAM BOX SIDE, bind off 2 sts. after Rows 262, 263, 264, 265; 3 sts. after Rows 266, 267, 268, 269, 270, 271; 13 sts. after Row 272.

ON EACH SIDE, increase 1 st. after Rows 36, 46, 56, 66, 74, 82, 90, 98, 106, 114, 122, 130, 138, 146, 154, 162, 170, 178, 186, 194, then knit to Row 202.

ROWS 0 to 36: Knit even.

Cast on 75 sts. and work stockinette st.

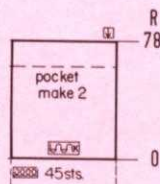

Cast on 45 sts. and work 78 rows stockinette st., then bind off all sts.

Work the second back section with reverse shapings, casting on from right to left. (Cam Box will be on the LEFT side at Row 0).

ON CAM BOX SIDE, bind off 4 sts. after Row 322 (EVEN ROWS = SHOULDER SHAPING); 15 sts. after Row 323 (ODD ROWS = NECK SHAPING); 4 sts. after Row 324; 2 sts. after Row 325; 4 sts. after Row 326; 2 sts. after Row 327; 4 sts. after Row 328; 2 sts. after Row 329; 4 sts. after Row 330; 2 sts. after Row 331; 4 sts. after Row 332; 1 st. after Row 333; 4 sts. after Row 334; 1 st. after Row 335; 4 sts. after Row 336; 1 st. after Row 337; 5 sts. after Row 338; 1 st. after Row 339; 5 sts. after Row 340.

ON CAM BOX SIDE, bind off 4 sts. after Rows 216, 218; 3 sts. after Rows 220, 222; 2 sts. after Rows 224, 226, 228; 1 st. after Rows 230, 232, 234, 236, 238, 250, 262, 274, 286, 298, 310, then knit to Row 322.

Increase 1 st. ON OPPOSITE SIDE of CAM BOX after Rows in (). ON CAM BOX SIDE, increase 1 st. after Rows 148, (148), 160, 172, 182, (182), 192, 202, (216), but do not knit after the last increase.

Decrease 1 st. ON OPPOSITE SIDE of CAM BOX after Rows in (). ON CAM BOX SIDE, decrease 1 st. after Rows 50, (50), 58, 66, (66), 74, 82, (82), 90, 98, (98), 106, 114, (114), 122, 130, (130), then knit to Row 148.

ROWS 0 to 50: Knit even.

Cast on 108 sts. and work stockinette st.

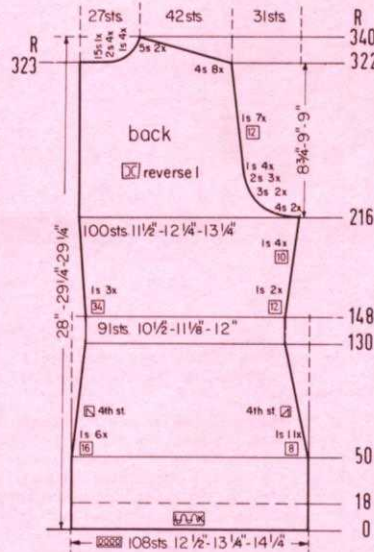

Cast on 32 sts. with color 1 and work stockinette st. After Row 40 work Short Rows. ON OPPOSITE SIDE of CAM BOX put into holding position 2 needles after Rows 40, 41, 42, 43, 44, 45, 46, 47, 48, 49, 50, 51, 52, 53. After Row 54 bring all needles back into working position and with a separate length of yarn, bind off all sts.

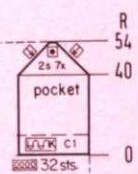

Work the second front section with reverse shapings, casting on from right to left. (Cam Box will be on the LEFT side at Row 0).

Decrease 1 st. ON NECK SIDE after Row in (). ON CAM BOX SIDE, bind off 3 sts. after Rows 172, 174; 2 sts. after Rows 176, 178; 1 st. after Rows 180, (180), 182. The Armhole Shaping is now completed. Continue to decrease 1 st. ON NECK SIDE after Rows 184, 188, 192, 196, 202, 208, 214, 220, then again after Row in (). For SHOULDER bind off 3 sts. after Rows 224, 226; (226), 4 sts. after Rows 228, 230, 232, 234.

Decrease 2 sts. for the DART and 1 st. ON CAM BOX SIDE after Rows 50, 60, 70, 80, 90, 100, 110, 120, then knit to Row 172.

ROWS 0 to 50: Knit even.

Cast on 68 sts. with color 1, work stockinette st. and the color stripes as marked in the Diagram.

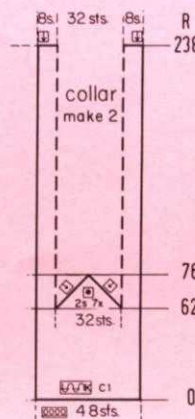
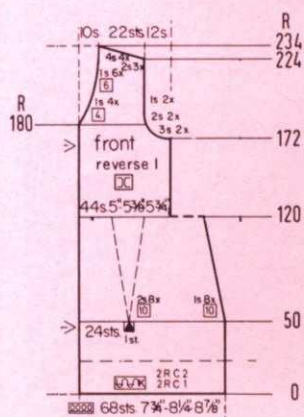

ROWS 63 to 238: Knit even, then bind off all 16 sts. Work the second collar section the same.

ON OPPOSITE SIDE of CAM BOX put into holding position 2 needles after Rows 62, 63, 64, 65, 66, 67, 68, 69, 70, 71, 72, 73, 74, 75. After Row 76 bring all needles back into working position, then bind off these sts. Now hang the 16 sts. held on contrast yarn back onto the machine, turn the Row Counter back to 62.

ROWS 0 to 62: Knit even, then take off 8 sts. ON EACH SIDE and work Short Rows over the remaining 32 sts.

Cast on 48 sts. with color 1 and work stockinette st.

Before working the collar, see practical knitting hint in the news letter.

KG 1958

CHAIR COVER

SIZE: Chair measures 16½" lower edge, x 13½" top edge, x 17½" deep. MATERIAL: 2 50 gr. balls Color 1 (A), 1 50 gr. ball Color 2 (E) KNITKING Dolly Dralon Crepe. Will make one Cover. USE JAC 40 and PATTERN NO. 107. Each row of the design counts as 1 row although several movements of the Cam Box are needed to complete one row. TENSION: 5 or 6. GAUGE: 15 sts. 19 Rows = 2".

FINISHING: Block and hide all ends. Stretch Cover over padded seat matching centers and tack or staple under seat. Work from side to side and top to bottom stretching evenly and miter the corners.

With Color 1, cast on 136 sts. Knit 6 rows stockinette stitch, then put Counter at 0 and begin Pattern. Mark center stitch with bit of contrast yarn. ON EACH SIDE, decrease 1 st. after Rows 46, 70, 94, 118, 142, 166. Knit even in Pattern to Row 184. Change to stockinette stitch and with color 1, knit to Row 190. Mark center stitch with bit of contrast yarn and bind off.

NOTE: To make it easy for you . . . You will put the JAC CARD through your JAC 40 4 complete times plus 24 more rows (5th time). The decreases are made after Rows 6 and 34 the 2nd time you put the JAC CARD through; after Row 18 the 3rd time; after Rows 2 and 26 the 4th time, and after Row 10 the 5th time.

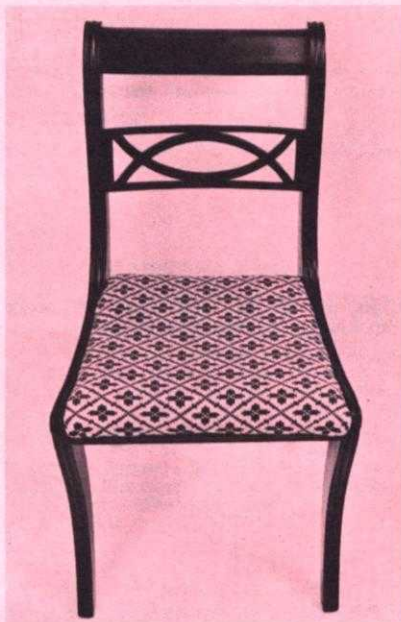

KG 1959

YARDSTICK HOLDER

MATERIAL: 2 50 gr. balls Color 1, small amounts of 3 contrasting colors KNITKING Dolly Dralon Crepe. Inexpensive plastic bracelet for hanger; yardstick. TENSION: 6 or 7. GAUGE: 13 sts. = 2½", 36 Rows = 2" measured over pressed pattern.

FINISHING: The PURL SIDE is the RIGHT SIDE. Hide all ends, then pin to board with knit side up and press with a warm DRY IRON. The piece should measure 2½" x 80". Put one end through bracelet and fold down 6" then pin in place. Fold other end up to within ½" of fold over top edge and pin carefully down the full length on both sides. Baste inside of picot then beginning 3½" from top, on side with opening, sew on sewing machine just inside the picot edge to within ½" of bottom, stitch across and then down other side to 3½" from top and across top to beginning of stitching. Pin the Hearts in place, spacing them evenly and alternating the colors. Thread end of yarn and sew around hearts with an invisible stitch.

Bring 17 needles into working position. Counting from the right side, put back to the out of work position, needles 3, 7, 11, 15 and leave them there. Cast on over the remaining 13 needles.

Knit 2 rows.

*Counting from the right, bring needles 2, 4, 7, 10, 12 into holding position, knit 4 rows.

Bring all needles back into working position, knit 2 rows. REPEAT from * to Row 1442. Bind off the crochet method.

HEARTS. Tension 6. Cast on 17 sts. Put the center needle into holding position, knit 6 rows. Return needle to working position. Knit 2 rows. ON EACH SIDE, decrease 1 st. by hanging the 2nd st. onto the 3rd needle and move the end sts. over to fill empty needles, knit 2 rows. REPEAT the decreases on each side, every other row till 3 stitches remain ending with 2 rows over the 3 sts. Break yarn leaving a long end, then bind off the 3 sts. at one time. Pull up the cast on edge tightly, (see Practical Knitting Hints Book, page 40).

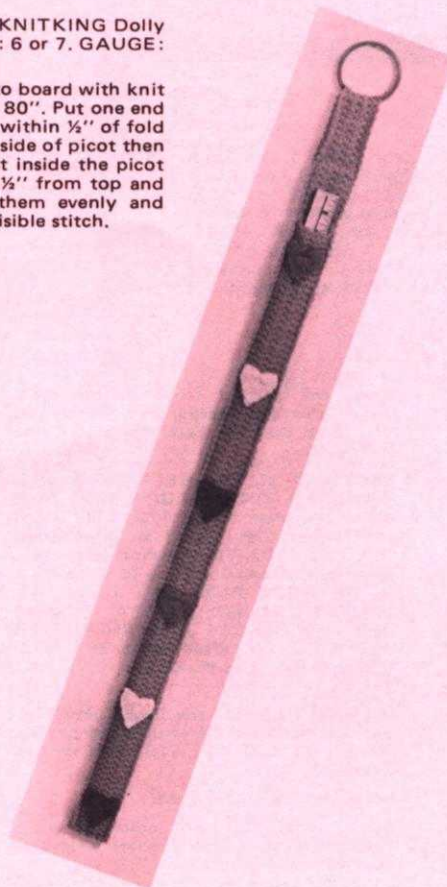

DP 8182 — Look slim and trim . . . Zip into a two-color Jacket that is designed for the larger figure. It is knitted in easy Stockinette stitch and the front Bands and Collar are made in one piece. Beatrice Crepe for Size 18; Regia for Size 20; Amore for Size 22.





Check Mates

HP 3696 — Let him make a big fashion splash . . . Checkerboard squares for a Man's sleeveless Pullover. Follow the Line Drawing for the Norwegian Design. The bands are a 1 x 1 Rib. Use KNITKING Allegro Dralon for Size 34; Dolly Dralon for Size 38.

MK 5421 — Double check this Teen size Pullover and knit it for your favorite gal. The Norwegian technique follows the Line Drawing. Knit Size 8 with KNITKING Allegro Dralon; Size 10 with Dolly Dralon.



DP 8180 -- Twice as nice . . . Twinsets are in . . . and you will look elegant in this lovely set. The Cardigan has a Norwegian Design Trim . . . the Pullover can be made with or without Mock Rib Bands (See Practical Knitting Hint in this issue). Size 16, KNITKING Regia; Size 20, Amore; Size 22, Alanda.

DK 8179 — A spectacular Pantsuit goes everywhere. Knit the Vest in a Holding Position Design following the Line Drawing or use your JAC 40 and Pattern No. 88. The Pants are made in stockinette stitch. Knit Size 10 with KNITKING Beatrice Crepe; Size 12 with Crocus Crepe; Size 16 with Dolly Dralon.









DP 8183 — Slim lines . . . soft texture . . . Flatter the full figure with an eye catching Jacket knitted in Stockinette stitch with an Eyelet and Cable Design on the front sections. **KNITKING** Beatrice for Size 20; Regia for Size 24; Amore for Size 44.

DP 8181 — Another Jacket for the fuller figure is knitted in a Holding Position Design and worn on the Purl side. **KNITKING** machine owners use Wheel No. 3. The Bands and Collar are in stockinette stitch. Knit Size 20 with **KNITKING** Regia; Size 24 with Amore.

KG 1959 — Hang your Yardstick on the wall tucked into a decorative Cover. It's knitted in a holding position Design and picot's form on the edges. The bright hearts for trim are quickly knitted in stockinette stitch and you can use them for trim on many other items as well. Use KNITKING Dolly Dralon Crepe.

KG 1958 — It looks like Needlepoint, but it's knitted on the KNITKING . . . Make your Chairs look like new with pretty Covers made in a 2-color Norwegian Design. Use your JAC 40 and Pattern No. 107 or any pattern of your choice. KNITKING Dolly Dralon Crepe is the yarn.

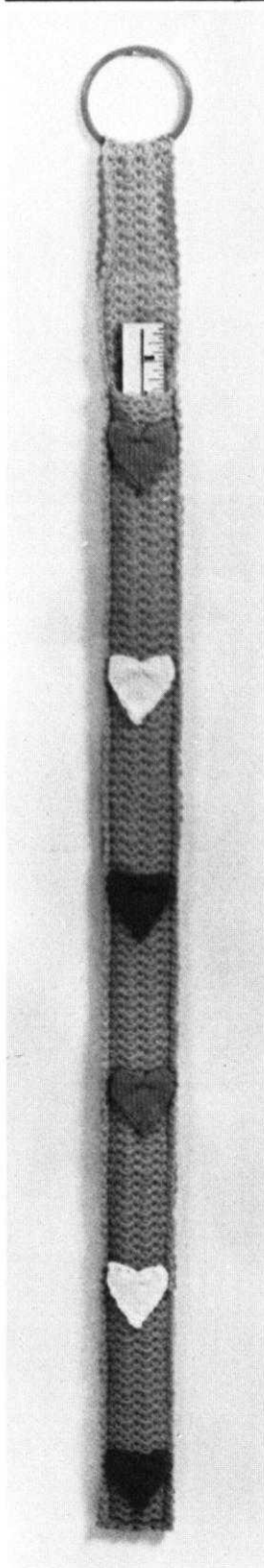

KnitKing News

SPECIAL YARN PURCHASE - HALF PRICE SALE

We recently purchased the entire stock of a beautiful Boucle Dress Yarn by Bucilla. Its name is HALO and it is a luscious lustrous Boucle Dress Yarn of 75% lofted Acetate and 25% texturized Nylon... You may have seen this Gorgeous Yarn in your local Department Store priced at \$1.10 an ounce... We had it dyed in an assortment of beautiful colors and wound on Cones... the average of which is 1 1/2 pounds... and we are offering it to you at HALF PRICE... 55¢ an ounce (\$8.80 per pound)...

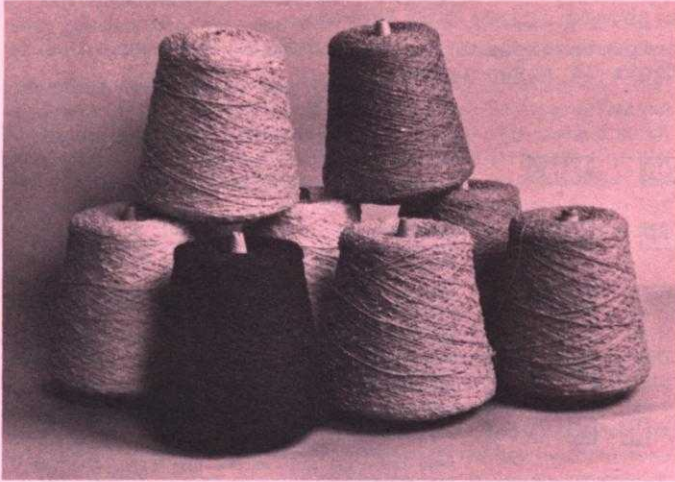

Gorgeous HALO knits up at a wide range of tensions. 8 stitches and 12 rows to an inch is ideal so you can use it for many KNITKING Patterns. This is a rare opportunity to buy a really top quality yarn at less than wholesale prices, so get your orders in early and have your choice of colors.

Everybody at KNITKING designed and made clothes for themselves in this outstanding yarn and we had a special Fashion Show for Southern California readers at our Los Angeles Store on Saturday, March 31st... We are sorry that all our readers could not be there, but we took photos of the garments and promise to publish the pictures as soon as possible. The Pantsuit Betty Atkin is wearing in the picture advertising the new Electric KNITKING Table in the center of this issue, is made of HALO (it took 48 ounces and cost \$26.40). We had a limited quantity of HALO in that shade of pink and it is all gone, but we have many other gorgeous colors to choose from...

LIST OF YARNS (COLORS)

No. 17 - Smokey Gold	No. 2 - Black
No. 16 - Oriental Blue	No. 7 - Coffee
No. 9 - Cherry	No. 6 - Orange
No. 18 - Royale (Blue)	No. 8 - Cream
No. 14 - Persimmon	No. 3 - Seal Brown
No. 13 - Lime	No. 5 - Amethyst
No. 1 - Angel White	No. 4 - Jade Green

Some colors will go very fast which is a hint for you to order as fast as you can and try to give at least two alternates... When this yarn is gone, there will be no more available anywhere... It

apparently is too expensive to produce, but at our prices, you can make an excellent two-piece outfit, that would cost over \$200.00 in a store, for approximately \$25.00.

You cannot buy less than 1 Cone (an average 1 1/2 pound cone costs \$13.20)... 2 cones will make a two-piece Suit or a long sleeved Dress and 4 cones should make a Suit and 2 short sleeved Dresses or Cardigans, etc...

Because it is not possible to wind cones weighing exactly 1 1/2 pounds, some are lighter and some heavier... If we have to supply you with a lighter weight cone than you order, you will get credit for the difference.

KNITKING OWNERS can knit directly from cones if they just drill a 1/4" hole (at a slight upward angle) in the center back of their Yarn Container... stand the cone on the floor behind a table or inside a desk, then feed the yarn through the hole and Tension Control in the normal manner... It works beautifully, but you must be sure to remove any burrs from the drilled hole.

We will accept BankAmericard or Master Charge on orders totaling \$25.00 or more and don't delay... order today. Shipping charges are: \$1.00 for the first 2 pounds plus 35¢ for each additional pound or fraction of pound. California residents be sure to add 5% Sales Tax.

BUCILLA PATTERN BOOKS

We also purchased a quantity of the two books - Heavenly Handknits and California Originals featuring Halo and Paradise Yarns. These excellent books illustrate a total of 14 garments in full color and are complete with hand knitting Instructions. They normally sell for one dollar each... Our price is two books for the price of one... \$1.00 plus 50¢ for first class mail or 25¢ for third class.

WHIZ KING PATTERN READER

Whiz King's are whizzing out in every mail... We are still selling them as fast as they arrive and haven't yet managed to complete the adaptors for all other brands... We really are as impatient as our customers to get them out, but work pressure has been even greater than usual these past few months...

Letters keep coming in praising this wonderful accessory....

Virginia Webb of Ormond Beach, Florida writes: "I have just received my WHIZ KING Pattern Reader and it is truly fabulous..."

Thelma Brown of San Luis Obispo says: "The Pattern Reader increases my speed at least four fold... I am amazed and very pleased..."

Mrs. Ed Williams of Tonawanda, New York writes: "This Pattern Reader sure is something... next best thing to the knitting machine..."

A.M. Stone of Durham, North Carolina writes: "I received my Pattern Reader and feel it is the best thing that has happened to machine knitters."

If you have not yet ordered a WHIZ KING, please do so now while the Special Introductory Price of \$49.50 is still in operation... the price has to increase by at least 10% shortly.

PRACTICAL KNITTING HINTS

MOCK RIBBING (To use for bands if you do not own a Ribbing Attachment). DP 8180 in this issue, has two sets of instructions for the Pullover bands. One is for knitting the bands with a Ribbing Attachment and the other for a Mock Rib - without a Ribber. If you have a Ribbing attachment, turn your Row Counter to 14 and cast on the number of sts. given first, then knit to Row 28 and change to stockinette stitch and continue knitting as instructed. A Mock Rib band is not quite as elastic as a regular Rib band, but is a good substitute. For the Mock Rib, cast on the number of sts. given in () using EVERY OTHER NEEDLE. Turn the tension setting 2 to 3 numbers lower than given tension and knit 28 rows. Now hang the cast-on sts. back onto the machine onto the same needles holding stitches, then bring the empty needles between those already in working position, into work. With your work hook, pick up each cross thread that spans from 1 st. to the other (release the sts. from under the sinkers first), twist the yarn, forming a loop, then place the loop onto the empty needle. After all the cross threads have been formed into loops and hung onto the empty needles, turn the tension to the proper setting for the rest of the garment section.

You can use this method for any garment with ribbed bands, but remember to turn the tension down and knit DOUBLE the number of rows given for a 1 x 1 rib band. After the band sections are completed, turn the Row Counter to the proper row and turn the tension to the correct number for your garment.

Another type of Mock Rib could be a 3 and 1 rib; This would be 3 needles in working position and 1 needle in the non-working position. Mock Rib bands should be blocked out in width then steamed in order to give them the ribbed look.

COLLAR and BAND KNITTED as ONE

There are several garments in this issue of KNITTING MAGAZINE that have the Collar and the Front Bands knitted as one... Patterns DP 8181, DP 8182 and MK 5417. We will use MK 5417 for our example and give you explicit instructions on how to accomplish this, then you can use the same method for the other two garments.

EXAMPLE: MK 5417

Make two sections for the Collar and Band... exactly alike. Begin with an open cast-on using waste yarn. Cast on 48 sts. with contrast waste yarn and knit several rows, ending with the Cam Box on the right side. Change to the garment yarn and turn the Row Counter to 0. Knit even to Row 62. ON OPPOSITE SIDE OF CAM BOX, put 40 needles into holding position. With contrast waste yarn, knit several rows over the 8 sts. on the right side, then remove the 8 sts. from the machine (move the Cam Box across the needles without yarn). With the Cam Box on the LEFT SIDE, bring 8 needles on the left side into working position, and knit several rows with contrast waste yarn over these needles then remove the sts. from the machine as you did before. Move the Cam Box to the right side and turn the Row Counter back to 62. First, bring all 32 needles back into working position, then work Short Rows. ON OPPOSITE SIDE OF CAM BOX, put 2 needles into holding position before knitting each of the next 14 rows. After Row 76, bring all the needles back into working position, then bind off the 32 sts. using a separate length of yarn. With the Purl side facing you, hang the 2 sets of 8 sts. held on contrast waste yarn, back onto the machine right

next to one another. Turn the Row Counter back to 62, remove the waste yarn and continue working over the 16 sts. to Row 238, then bind off the 16 sts. Work the second Collar section the same way. After both sections are completed, block them and then weave the two sections together at the center back. Remove waste yarn.

NEW PATTERN SYMBOLS

Readers will notice that some new Symbols have been added to the garment Charts on the Instruction pages of this issue... These symbols also appear on Charts for use with the WHIZ KING Pattern Reader.

Many experienced knitters do not use the written instructions at the side of the charts in KNITTING MAGAZINE... they prefer to just follow the Charts... These new Symbols make it easier for them... If you read the written Instructions, you should ignore the Symbols...

A complete explanation of KNITTING Pattern Symbols is given below.

KNITTING PATTERN SYMBOLS	
	1. Cast on
	2. Stockinette stitch - worn on the Knit side
	3. Stockinette stitch - worn on the Purl side
	4. Knit 1, Purl 1, Ribbing
	5. Ribbing Pattern - worn on the Purl side
	6. Ribbing Pattern - worn on the Knit side
	7. Put on a stitch holder
	8. Pattern Stitch
	9. Knit Stitch
	10. Purl Stitch
	11. Needles back into working position
	12. Empty needle (leave in working position)
	13. Needle not used (in the out of work position)
	14. Needle in holding position
	15. Two stitches on 1 needle - either transferred from the right side or the left side, then put into holding position
	16. Needle holding 2 stitches. Stitch has been transferred from the LEFT
	17. Needle holding 2 stitches. Stitch has been transferred from the RIGHT
	18. 3 stitches on 1 needle. The 1st and 3rd stitch in a group of 3 needles has been hung on the 2nd or center needle
	19. Row
	20. Bind off
	21. Number of rows to be knitted between shapings
	22. Tension
	23. Gauge
	24. Reverse one section
	25. On every other needle
	26. Open Dart
	27. Closed Dart
	28. Short Row increase or decrease, for instance on flared skirt knitted sideways
	29. Pattern stitch - worn on the Knit side
	30. Pattern stitch - worn on the Purl side
	31. Center of garment section
	32. Work 1 (2 etc.) rows single crochet around edges
	33. Turn to the wrong side and hem
	34. Ease
	35. Match numbers on sections for assembling
	36. Hem
	37. Fold line
	38. Color number (example - C1 = Color 1)
The Roman numeral numbers shown on each garment section are as follows:	
I	= Front
II	= Back
III	= Sleeve
IV	= Skirt Front
V	= Skirt Back
VI	= Collar
VII	= Pocket
VIII	= Band
IX	= Belt
X	= Cuff

NOTES TO KNIT BY . . .

STITCH AND ROW GAUGE

KNIT A SAMPLE SWATCH . . . before you begin to knit any garment . . . for this is the MOST IMPORTANT STEP toward the correct size and the proper fit of any garment you wish to make. You MUST use the SAME YARN for your sample swatch that you will use to knit your garment and your sample swatch must be knitted large enough and using several different tension numbers on your machine. When you have done this, then you can determine the number of stitches and the number of rows in a two-inch measure. KNITTING MAGAZINE PATTERNS give you 3 tensions to try and one of them should give you the correct stitch and row gauge if you are using the yarn we recommend or a similar weight yarn. Here is the way to make your sample swatch.

Cast on over a sufficient number of needles to produce a swatch at least 4 inches wide. (If the pattern calls for 16 stitches to 2", then $16 \times 2 = 32$ stitches to cast on). Now knit 4 inches of rows at the first suggested tension number. (If the pattern calls for 22 rows to 2", $22 \times 2 = 44$ rows to knit). Knit 2 rows using a contrast color, change to the next higher tension and with garment yarn knit another 4", knit 2 rows with contrast color, change to the 3rd higher tension and knit another 4" and then bind off.



Roll the swatch into a cylinder over its length and pull on both ends, unroll it and stretch it diagonally by pulling on the four corners. Allow the swatch to rest and settle (preferably overnight) and then using a stitch gauge or a ruler, count the number of stitches over a 2" width, then the number of rows over a 2" length in EACH of the 3 tensions. Select the tension number that produces the stitches and rows called for in the pattern. If none of them are correct, you are most likely using the wrong weight of yarn.



READING OF CHARTS

You will notice the instructions start at the bottom of the Chart and work UP. Follow the charts exactly as written and providing your sample stitch and row gauge is correct, your garment will come out the right size. Please remember that the section of garment as it is knitted on the machine, faces the same way as the Charts are in this magazine. Where two front pieces are needed, (or any other part of a garment that needs two sections) only one section is normally shown and the second section is usually made with reverse shapings. Set in sleeves are usually identical, but raglan sleeves have to be knitted with reverse shapings for the second sleeve.

READING OF SYMBOLS

To simplify Pattern Knitting, we use Symbols in the Line Drawings and the Chart Diagrams. In the Line Drawings the symbols are shown and are to be read as you look at them while knitting a garment. For instance, if

a Purl stitch faces you, the Purl stitch Symbol  is shown; if a knit stitch faces you (as when using the Ribber) then this Symbol  is shown. The Symbol  at the top of the Line Drawing is the center of the garment section and you use this as a guide for setting up the needles.

The following Symbols    are used for Eyelet Designs in the Line Drawings and also for Full Fashion shaping on the Charts. The Line Drawings have row numbers on the right side. Missing Row numbers are always knitted straight or plain.

In Holding Position Designs  selected needles are pushed into holding position for the stated number of rows. The numbers of rows appear at the right of the Line Drawings; Example: 1-4 means knit Rows 1 to 4; 5 to 7 means knit Rows 5 to 7, etc. This same Symbol is also shown on the Charts and is used for putting needles into holding position for Short Rows. The

Symbol  on the Charts is used to put needles back into working position when knitting Short Rows.

A number in a box stands for the number of rows to be knitted between shapings. Make shaping first, then knit the necessary number of rows. If for instance it reads:

1 st. 8 x



1 st. 10 x





As you will be reading the instructions from the bottom up, here is the way you will follow them: . . . Decrease or increase (depending on the direction of the garment outline) 1 st. at the row where the shaping begins, then knit 8 rows, make the next decrease, then knit 8 rows, until you have decreased (or increased) 1 st. 10 x and you have knitted 8 rows after each decrease (or increase) (1 st. 10 x +8 rows 10 x). Now begin the first decrease (or increase) for the shaping (which has to be made 8 x) in every 6th row. Decrease (or increase) 1 st. first, then knit 6 rows until you have decreased 1 st. 6 x and after each decrease (or increase) have knitted 6 rows (1 st. 8 x + 6 rows 8 x).

Where shapings are given without a boxed number as on most armholes, necklines, etc., make the shapings on every second row (on each side of course).

(See below for more Pattern Stitch Symbols.)

PATTERN STITCH SYMBOLS

 = knit stitch

 = purl stitch

 = empty needle (leave in working position)

 = needle not used (in the out of work position)

 = needle in the holding position

 = Needles back into working position.

 = 2 stitches on 1 needle — either transferred from the right side or the left side, then put the needle into holding position

 = needle holding 2 stitches. Stitch has been transferred from the LEFT

 = needle holding 2 stitches. Stitch has been transferred from the RIGHT

 = 3 stitches on 1 needle. The 1st and 3rd stitch in a group of 3 needles has been hung on the 2nd or center needle.

 = Center of Garment Section.

 = Number of rows to be knitted between shapings.

The diagrams (Line Drawings) for pattern work are followed just as they are shown and are to be read as you look at them while knitting the garment.

open darts



closed darts



