

knitking

magazine

july/aug. '73



a bonus pattern

DK 8221 — Party Pantsuit. Be the envy of your friends and knit this beautiful Pantsuit with KNITKING Monofil for the Pattern Design on the sleeves of top and the lower

edge of Pants. Follow the Line Drawing or use JAC 40 and Pattern No. 472. Sizes 8 to 10, Amore; Sizes 12 to 14, Crocus Crepe; Sizes 16 to 18, Allegro — plus Monofil.



knitking

magazine

INDEX

PAGE NO.

DP 8191	Woman's Tunic	9
HP 3698	Man's Pullover	9
DK 8194	Woman's 2 piece Suit	11
DK 8185	Woman's Pants, Pullover & Cap	12
DK 8166	Woman's Dress	12
DK 8167	Pants and Jacket	14
HP 3693	Man's Pullover Shirt	15
DK 8170	Woman's Dress	17
DK 8221	Woman's Pantsuit	17
DK 8223	Evening Dress	18
DK 8208	Bride's Dress	20
DK 8222	Woman's Cape	20
DP 8216	Woman's Tunic	22
MK 5416	Girl's Dress	22
MK 5432	Girl's Dress	23
DK 8186	Woman's Jumper & Pullover	24
HP 3699	Man's Jacket	25
KK 5414	Boy's Pants and Top	26
KG 1960	Gingerbread Toy or Pillow	27
KG 1961	Golf Club Mitts	27
KG 1962	Hairpin Lace Beret	28



SUMMER ... a time for romance ... vacation travels and parties ... KNITKING helps you to prepare for all of this ... and more too ... with super fashion knits in this very beautiful issue of KNITKING MAGAZINE.

FRONT COVER

Our Cover Model Tunic DP 8191 is knitted in the ever popular Hounds Tooth Pattern. Designed to be worn with or without a blouse, it's perfect to wear over pants or a plain knitted skirt. Use JAC 40 Pattern No. 465 or follow the Line Drawing. Knit Size 10 with KNITKING Beatrice Crepe; Size 12 with Crocus Crepe; Size 16 with Melodie.

BACK COVER

CHECK this bright Pullover HP 3698 for your Man ... Four colors are combined and knitted in a holding position Design (a chance to use your Cam Wheel No. 1) for the front and back sections. The sleeves are in stockinette stitch and all bands are a 1 x 1 Rib. Size 38 and 40 are made with Allegro; Size 44 with Dolly Dralon Crepe.

Publisher: KNITKING CORPORATION, 1128 Crenshaw Blvd., Los Angeles, Calif. 90019. Telephone: 213-938-2079. Published bi-monthly. Subscriptions: USA - \$7.00 annually, single copies \$1.50; Canada - \$8.00; other parts of the world - \$10.00. The entire contents of KNITKING MAGAZINE are copyright and must not be reproduced in any shape or form without the express permission, in writing of the publisher. COPYRIGHT © by KNITKING CORPORATION 1973.
 Printed by William B. Wemyss Printing Associates, Los Angeles, Ca.

editorial

It seems, from the very substantial volume of correspondence we receive on the subject, that the biggest problem machine knitters have is the charting of custom garments ... Modern knitting machines are marvels of engineering and they are designed to perform in many varied and wonderful ways. Once a user learns how to control her machine, and understands its operation she normally has no problem completing any of the garments in KNITKING MAGAZINE ... Problems only arise when she needs to knit a garment in a different weight yarn to that recommended in a pattern or (the most common problem) knitting in a larger or disproportionate size ... Very few people are what is known as a perfect size, so adjustments frequently need to be made, to allow for larger or smaller busts and hips etc., etc. ...

Several years ago, we decided to produce a Pattern Charting Book that would assist machine knitters in the design and charting of garments. We studied most of the available books and material on the subject before preparing our own book, then we found that one book would not be sufficient so we decided to develop several, covering different types of garments ... After several months work on this series of books the whole project became so complex we worried that a large number of readers would find standards that a professional could use, far too complicated to understand ... Consequently, we shelved the project while we continued to search for more simple methods and procedures. We believe that we can now see light at the end of the tunnel and we are speedily developing a simple uncomplicated system of custom charting ... Watch forthcoming issues of KNITKING MAGAZINE for more news regarding this exciting innovation.

Isn't this issue of KNITKING MAGAZINE BEAUTIFUL??? We even include a bonus Pattern on the inside front Cover. We have another lovely issue coming up for September/October. It will include some very cleverly designed garments for the fuller figure ... very handsome Jacquard designs for all members of the family ... warmer garments for the winter months and in the Gift Section ... something new - a very attractive Hat and Scarf in a crochet type stitch.

BOOKS by KNITKING

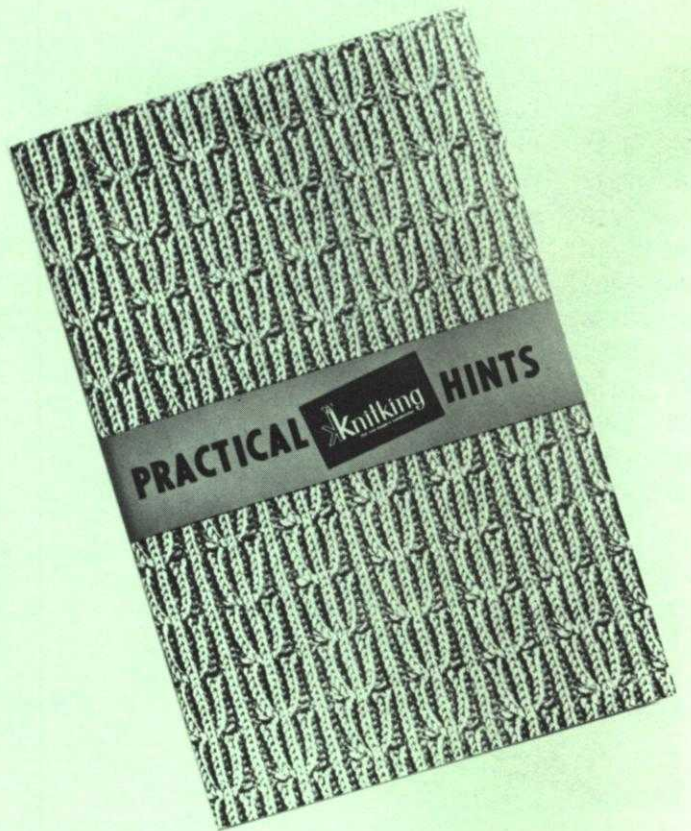

PRACTICAL KNITTING HINTS

We call this book the TEXT BOOK for machine knitters because it answers the many questions that occur in machine knitting, from preparing to knit, taking measurements, shaping, making buttonholes, special effects, bindings, bands and edges, etc., through finishing and blocking. It sells for **\$2.95**

40 cents mailing
Calif. residents add 5% Sales Tax



NEW VOLUME AVAILABLE NOW

A complete eighth volume of **KNITKING MAGAZINES** with a flexible, transparent plastic cover and specially bound so that it will stay open at any page, is available at the special price of **\$7.95** (plus 95 cents mailing costs).

The volume contains over 120 fully illustrated complete stylish patterns for all members of the family together with many valuable, practical knitting hints.

There is a very limited number of these volumes available and it will undoubtedly become a collectors item.

If you already have the entire set it will almost certainly be well thumbed and marked. Why not purchase a perfect mint condition volume for your bookshelf and ready reference at any time.

Place your order today and avoid disappointment. Send it to **KNITKING MAGAZINE**, 1128 Crenshaw Boulevard, Los Angeles, California 90019.

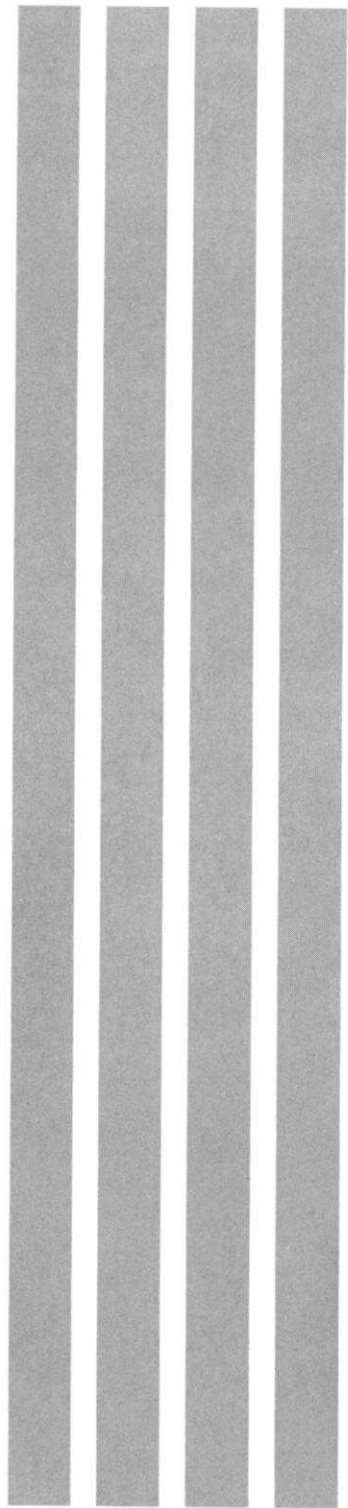

DK 8185 — Knit a Pantsuit with matching Cap in just a few hours. Take note of the new wide cuffs on the pants. The Top is striped and made in two sections only (increases make the sleeves). Wear the Top over a Blouse for a layered look, or wear it without. Size 8, KNITKING Amore; Size 12, Alanda.



neat and nice

DK 8166 — The perfect Travel Dress is easy to wear and easy to care for. You will enjoy knitting this one in a JAC 40 Design using two colors and different yarns . . . Toss it into the washer and dryer and it is ready to wear again. Size 8, 12 and 14 are made with KNITKING Melodie and Allegro Dralon.

DK 8167 — Pack a Pantsuit for travel comfort. The Jacket is made in a holding position Design (KNITKING owners use Cam Wheel No. 6) with colorful striped bands. Make it serve double duty and wear it over a summer dress or with the pants. Size 12 and 14, Regia with Beatrice Crepe for the bands.



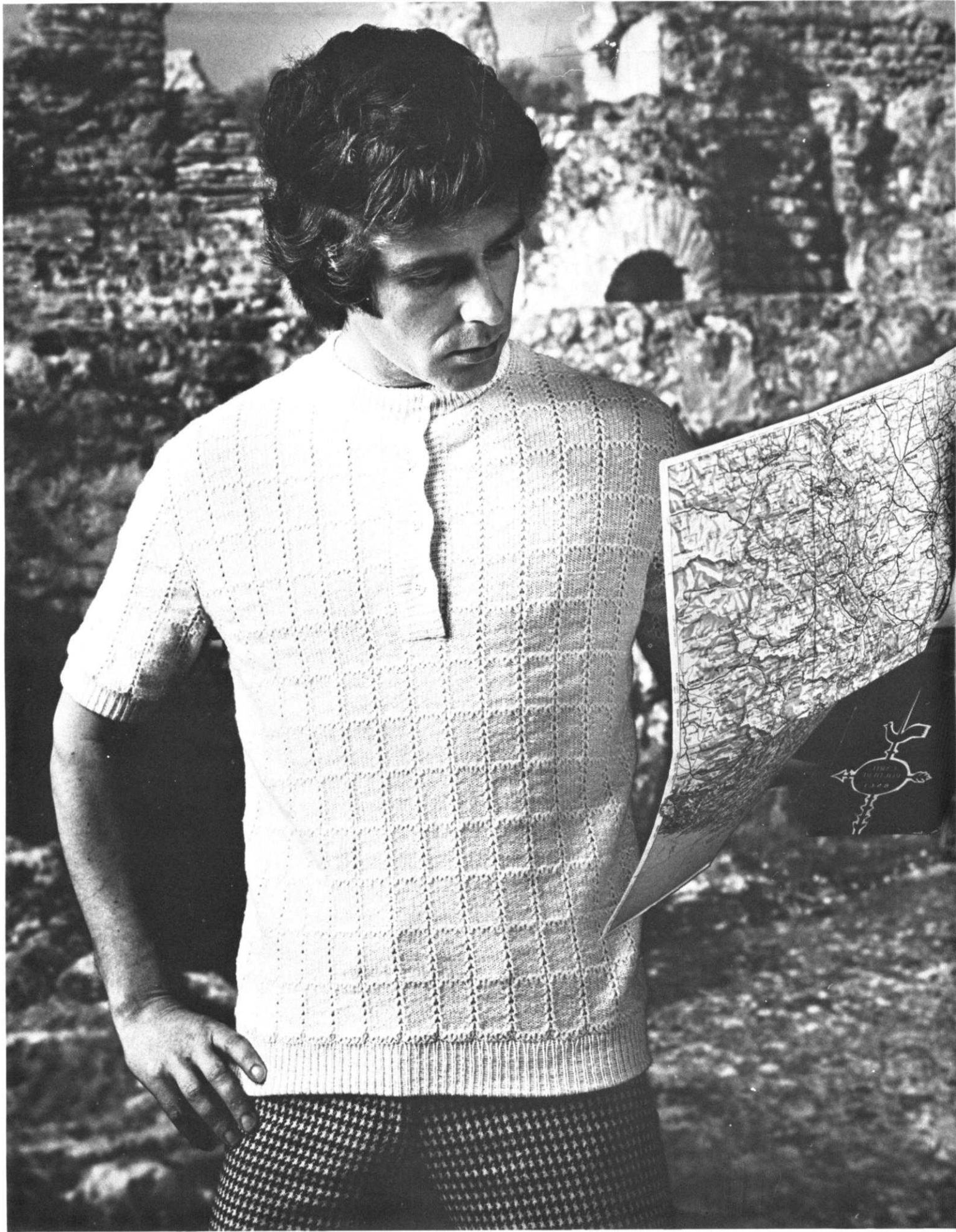

HP 3693 — ON THE MOVE . . . or at any stopover, he will wear this handsome Pullover. It's knitted with Melodie in a holding position Design. The Purl side is the right side. Sizes 38, 40 and 44.

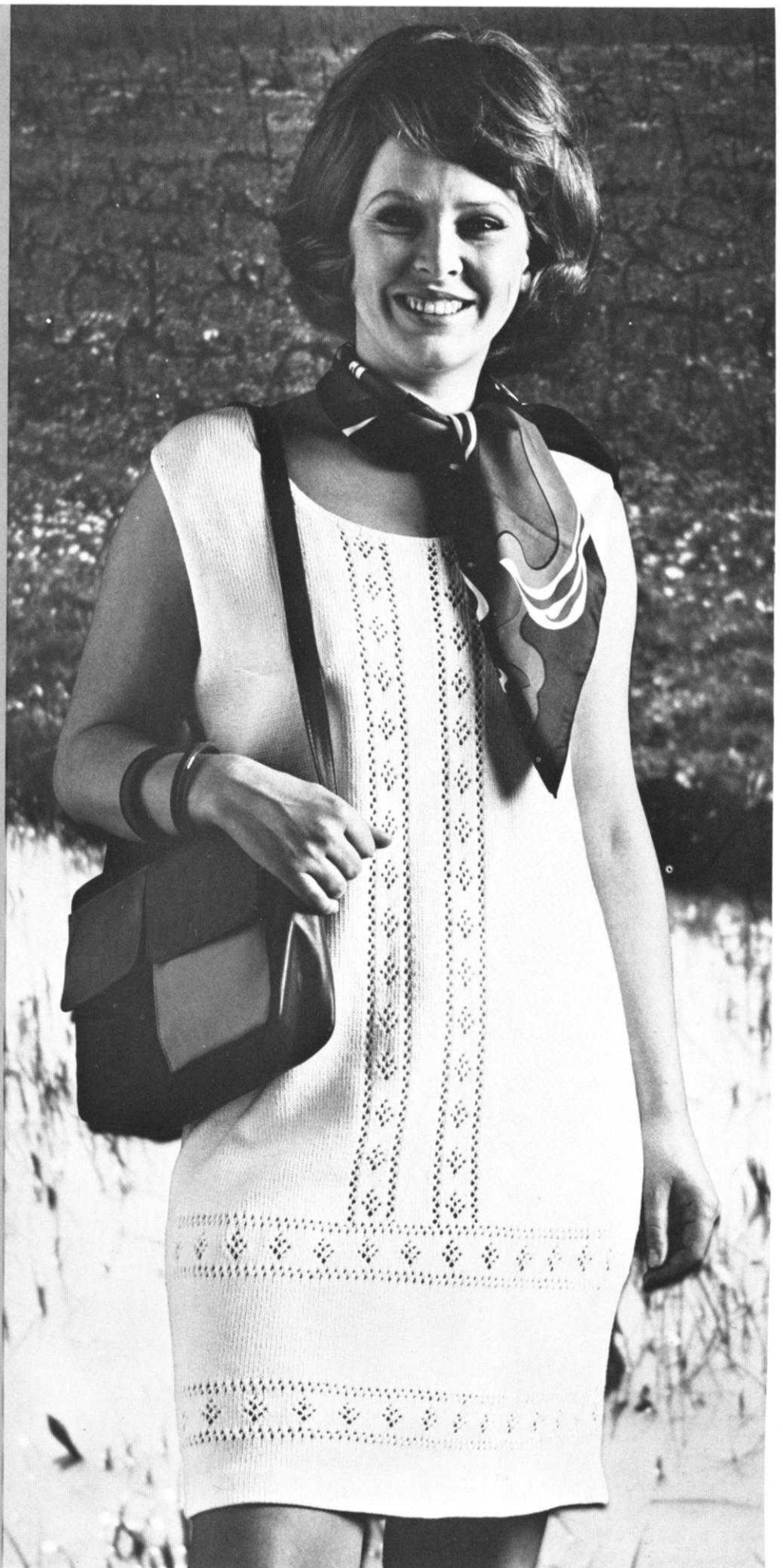

DK 8170 — Super cool and feminine . . . Wear this lovely Dress for any occasion at home or away. Knit it in Stockinette stitch with an Eyelet Design border on the lower edge and down the front section. Size 16 is made with Beatrice Crepe; Size 18 and 20 with Regia.



for life and love

DK 8122 — Designed for NOW . . . Feel elegant, look gorgeous . . . All eyes are on a sumptuous long Cape with great knotted moving Fringe. Three sizes are given; small, medium and large. Knit all sizes with beautiful KNITKING Melodie.

DK 8223 — The long Dress peeking out from under the Cape is for any gala occasion . . . It's beautifully fitted and is sleeveless. Easy to knit in Stockinette Stitch. Sizes 8, 12 and 14 are made with Beatrice Silver.

DK 8208 — Summer Wedding . . . The Bride is radiant in an old fashioned style gown. Romantic Lace makes up the skirt sections and head Scarf, with the bodice and puffy sleeves in stockinette stitch. We are using our new MONOFIL thread to make the lace. You can follow the Line Drawing for the Pattern or use JAC 40 and Pattern No. 478. Sizes 10 and 12, Beatrice Crepe; Size 14, Crocus Crepe — plus KNITKING Monofil.



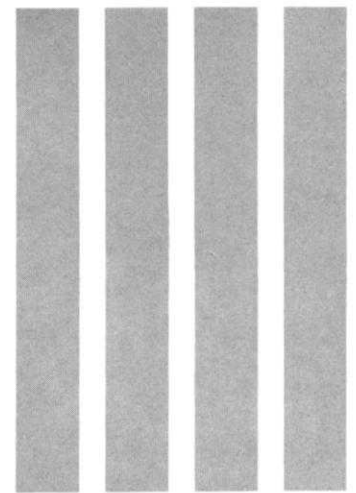

KG 1961 — Make up some Mitts for his valuable Golf Clubs. Stockinette stitch with Ribbing. The stripes represent numbers 1, 2, 3 and 4 and a knitted cord ties them all together. Sport Prima is the yarn.



KG 1960 — A cuddle toy or pillow — just the right size for a small child (Teenagers will love him too). Knit the Gingerbread toy with Flamingo Dralon, the icing trim with Allegro.

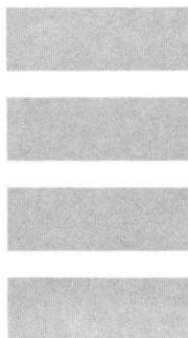

KG 1962 — Hairpin lace made in rounds then latched together turns into a really darling Beret. Knit it with KNITKING Dunja using two colors.

DPS191

SIZE:	10 (Bust 32"-33")	12 (Bust 34"-35")	16 (Bust 37"-38")
YARN:	Beatrice Crepe	Crocus Crepe	Melodie
50 gr. BALLS:	6 color 1 5 color 2	7 color 1 6 color 2	7 color 1 6 color 2
TENSION:	4 to 6	6 to 8	7 to 9
GAUGE:	2" 17 sts. 23 rows	16 sts. 21 rows	15 sts. 20 rows

The instructions are the same for all sizes. PATTERN: Norwegian Design according to the Line Drawing, or use JAC 40 and Pattern No. 465. In the instructions, each row in the Norwegian Design is counted as 1 row, but several movements of the Cam Box are needed to complete 1 row. EDGES: Stockinette Stitch. Make all shapings on the outside edges.

FINISHING: Block all sections. Join the sections at sides and shoulders, easing in the fullness at bustline of the front section. With color 1 and 1 tension setting lower, work the binding over 9 sts. Knit 290 rows for the neckline, 200 rows for each armhole, 290 rows for the lower edge of the front and 290 rows for the lower edge of the back section. Sew 1 edge of the binding to the inside and 1 edge to the outside of all edges.



Bring the needles on the left side into working position, knit 1 row in PATTERN to the left side, turn the Row Counter back to 282 and complete the left half. Follow the instructions from*.

*ON CAM BOX SIDE, bind off 3 sts. after Rows 283, 285, 287 (ODD ROWS = NECK SHAPING); 2 sts. after Rows 289, 291, 293; 4 sts. after Row 294 (EVEN ROWS = SHOULDER SHAPING); 2 sts. after Row 295; 4 sts. after Row 296; 1 st. after Row 297; 4 sts. after Row 298; 1 st. after Row 299; 5 sts. after Rows 300, 302.

ON CAM BOX SIDE, bind off 4 sts. after Rows 210, 211; 3 sts. after Rows 212, 213, 214, 215; 2 sts. after Rows 216, 217, 218, 219, 220, 221; 1 st. after Rows 222, 223, 224, 225, 226, 227, 228, 229, 230, 231, then knit to Row 282, bind off the center 27 sts., put the needles on the left side into holding position and complete the right half first. (You may work the opposite shaping at the same time by using separate balls of yarn for each side).

ON EACH SIDE, increase 1 st. after Rows 134, 146, 158, 170, 182, 194, then knit to Row 210. (For the Front Section knit to ROW 210).

ON EACH SIDE, decrease 1 st. after Rows 58, 68, 78, 88, 98, 108, 118, then knit to Row 134.

ON CAM BOX SIDE, cast on 4 sts. after Rows 2, 3, 4, 5; 3 sts. after Rows 6, 7, 8, 9; 2 sts. after Rows 10, 11, 12, 13; 1 st. after Rows 14, 15, 16, 17, 18, 19, 20, 21, 22, 23, 26, 27, 30, 31, 34, 35, 38, 39, 42, 43, then knit to Row 58.

Cast on 97 sts. and work the Norwegian Design.

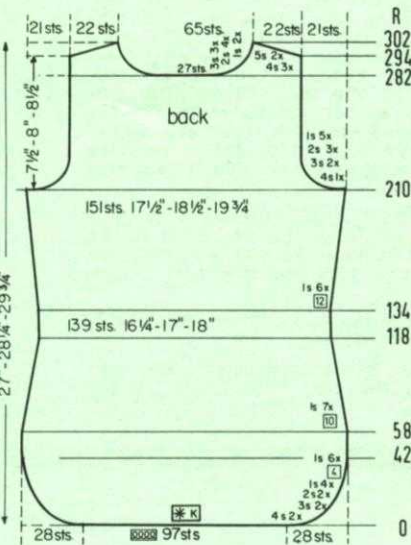
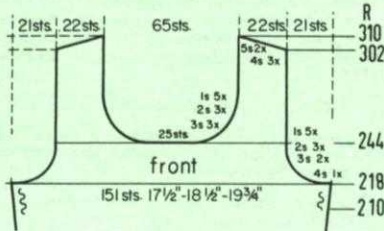

Bring the needles on the left side into working position, knit 1 row in PATTERN to the left side, turn the Row Counter back to 244 and complete the left half. Follow the instructions from*.

*ON CAM BOX SIDE, bind off 3 sts. after Rows 245, 247, 249; 2 sts. after Rows 251, 253, 255; 1 st. after Rows 257, 259, 261, 263, 265. For SHOULDER bind off 4 sts. after Rows 302, 304, 306; 5 sts. after Rows 308, 310.

ON CAM BOX SIDE, bind off 4 sts. after Rows 218, 219; 3 sts. after Rows 220, 221, 222, 223; 2 sts. after Rows 224, 225, 226, 227, 228, 229; 1 st. after Rows 230, 231, 232, 233, 234, 235, 236, 237, 238, 239, then knit to Row 244, bind off the center 25 sts., put the needles on the left side into holding position and complete the right half first.

ROWS 211 to 218: Knit even.

Work the front section the same as the back section to ROW 210.

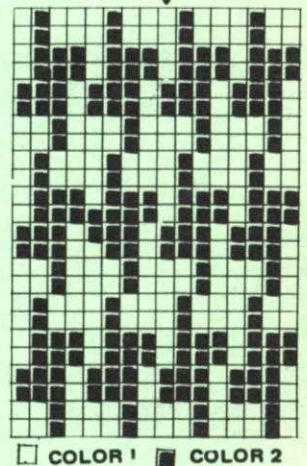

HP369S

SIZE:	38 (Chest 37"-38")	40 (Chest 39"-40")	44 (Chest 43"-44")
YARN:	Allegro Dralon	Allegro Drajon	Dolly Dralon
50 gr. BALLS:	5 color 1 3 color 2 3 color 3 1 color 4	6 color 1 3 color 2 3 color 3 1 color 4	7 color 1 4 color 2 4 color 3 1 color 4
TENSION:	7 to 9	8 to 10	9 to 10
GAUGE:	2" Stk.: 15 sts. 21 rows Pattern: 15 sts. 23 rows	14 sts. 20 rows 14 sts. 22 rows	13 sts. 19 rows 13 sts. 21 rows

The instructions are the same for all sizes. PATTERN: Holding Position Design according to the Line Drawing, using Wheel No. 1. SLEEVES: Stockinette Stitch. EDGES: K1, P1, Ribbing. INCREASES: Move the 2 end sts. 1 needle outward, then place the 3rd st. from the row below onto the empty needle.

FINISHING: Block all sections. Join front and back section at sides and shoulders. Sew the sleeves together and set in. Join the short ends of the neckband, then sew 1 edge to inside and 1 edge to outside of the neckline.

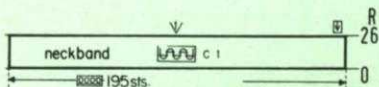

Cast on 195 sts. with color 1 and work 26 rows K1, P1, Ribbing, then bind off all sts.

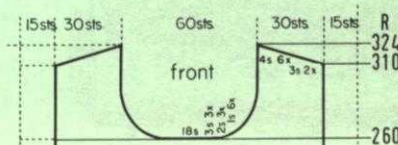

Bring the needles on the left side into working position, knit 1 row in PATTERN to the left side, turn the Row Counter back to 260 and complete the left half. Follow the instructions from*.

*ON CAM BOX SIDE, bind off 3 sts. after Rows 261, 263, 265; 2 sts. after Rows 267, 269, 271; 1 st. after Rows 273, 275, 277, 279, 281, 283. For SHOULDER bind off 3 sts. after Rows 310, 312; 4 sts. after Rows 314, 316, 318, 320, 322, 324.

Work the front section the same as the back section to ROW 260, then bind off the center 18 sts., put the needles on the left side into holding position and complete the right half first.

Continued on page 10

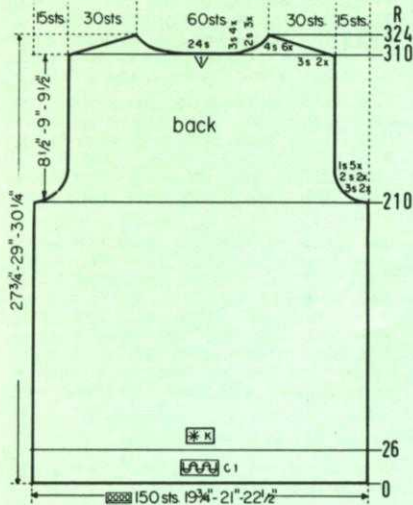

Bring the needles on the left side into working position, knit 1 row in PATTERN to the left side, turn the Row Counter back to 310 and complete the left half. Follow the instructions from*.

*ON CAM BOX SIDE, bind off 3 sts. after Rows 310 (EVEN ROWS = SHOULDER SHAPING), 311 (ODD ROWS = NECK SHAPING), 312, 313; 4 sts. after Row 314; 3 sts. after Row 315; 4 sts. after Row 316; 3 sts. after Row 317; 4 sts. after Row 318; 2 sts. after Row 319; 4 sts. after Row 320; 2 sts. after Row 321; 4 sts. after Row 322; 2 sts. after Row 323; 4 sts. after Row 324.

ON CAM BOX SIDE, bind off 3 sts. after Rows 210, 211, 212, 213; 2 sts. after Rows 214, 215, 216, 217; 1 st. after Rows 218, 219, 220, 221, 222, 223, 224, 225, 226, 227, then knit to Row 310, bind off the center 24 sts., put the needles on the left side into holding position and complete the right half first. (For the Front Section knit to Row 260).

ROWS 27 to 210: Knit even.

ROWS 0 to 26: Knit even, then change to stockinette st. and work the Holding Position Design.

Cast on 150 sts. with color 1 and work K1, P1, Ribbing.

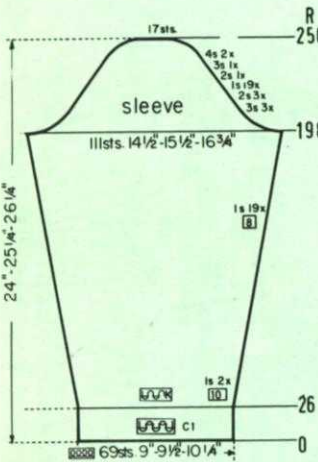

ON CAM BOX SIDE, bind off 3 sts. after Rows 198, 199, 200, 201, 202, 203; 2 sts. after Rows 204, 205, 206, 207, 208, 209. ON EACH SIDE, hang the 1st st. onto the 2nd st. after Rows 210, 212, 214, 216, 218, 220, 222, 224, 226, 228, 230, 232, 234, 236, 238, 240, 242, 244, 246. ON CAM BOX SIDE, bind off 2 sts. after Rows 248, 249; 3 sts. after Rows 250, 251; 4 sts. after Rows 252, 253, 254, 255; 17 sts. after Row 256.

ON EACH SIDE, increase 1 st. after Rows 26, 36, 46, 54, 62, 70, 78, 86, 94, 102, 110, 118, 126, 134, 142, 150, 158, 166, 174, 182, 190, then knit to Row 198.

ROWS 0 to 26: Knit even, then change to stockinette st.

Cast on 69 sts. with color 1 and work K1, P1, Ribbing.

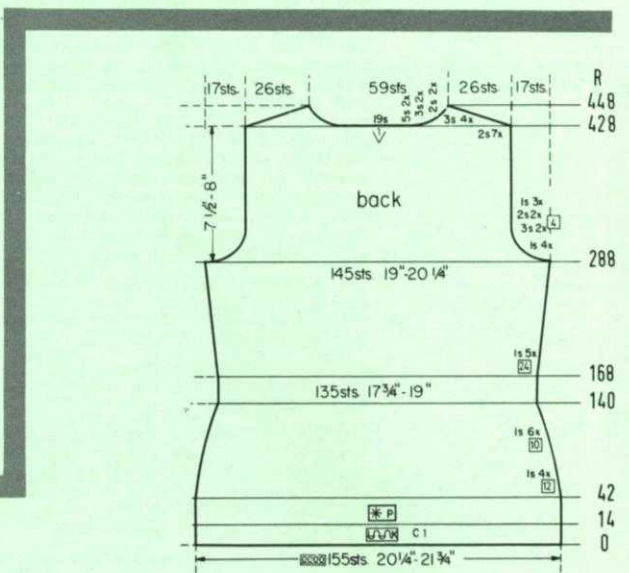
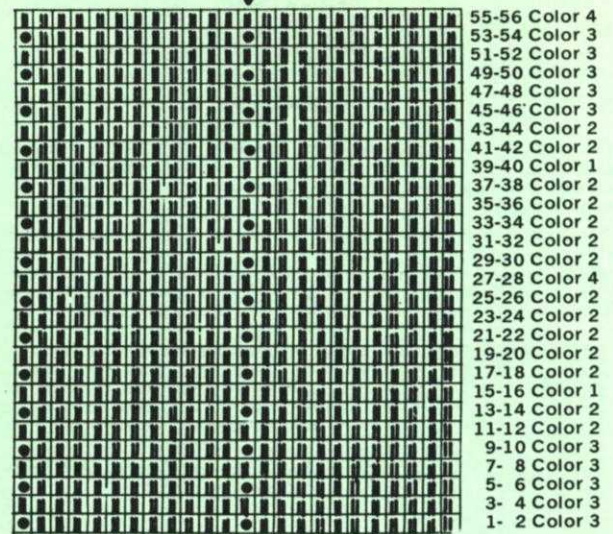

(Jac40 is a must)



for fast easy knitting of Jaquard and Ski-sweater designs

Patterns are selected - row by row - through a pre-stamped card that is fed into the Jac.



There are over 300 cards available and illustrations of them are included with each Jac.

Jac 40's are made for most brands of machines. When ordering be sure to specify your brand of knitter as needle spacings vary. Simple to use and an essential tool for the modern knitter, Jac 40's are \$26.95 complete with 3 cards for practicing the 3 techniques, plus complete instructions.

Order from your dealer or direct from
KNITKING

1128 Crenshaw Boulevard, Los Angeles, Calif. 90019

Shipping Cost \$1.25 - California residents add 5% sales tax.

DK8194

SIZE: 14 (Bust 35"-36") 16 (Bust 37"-38")

YARN:
BASIC: Beatrice Crepe (C1) Beatrice Crepe (C1)
WEAVING: Dolly Crepe (C2) Dolly Crepe (C2)

50 gr. BALLS: 10 color 1 11 color 1
 7 color 2 8 color 2

TENSION: 4 to 6 5 to 7

GAUGE: 2" Stk.: 15 sts. 24 rows 14 sts. 23 rows
 Pattern: 15 sts. 37 rows 14 sts. 35 rows



The instructions are the same for both sizes. **PATTERN:** Weaving Design using the Weaving Attachment. Follow the Line Drawing, or use JAC 40 and Pattern No. 466. The purl side is the right side. **EDGES:** Stockinette Stitch worn on the knit side. Make all shapings of 1 st. on the outside edges.

FINISHING: Block all sections. **SKIRT:** Join the sections at sides. Turn under 2" at lower edge and 1" at upper edge and hem to wrong side. Insert an elastic band into the upper hem. **JACKET:** Join back and front sections at sides and shoulders, easing in the fullness at bustline of the front sections. Sew the sleeves together and set in. Turn over 7 rows on lower edge and sleeve edges and hem to right side. Sew 1 edge of the neckband to inside and 1 edge to outside of the neckline. Sew the front bands to the front edges in the same manner.

Bring the needles on the left side into working position, knit 1 row in **PATTERN** to the left side, turn the Row Counter back to 428 and complete the left half. Follow the instructions from *.

*ON CAM BOX SIDE, bind off 2 sts. after Row 428 (EVEN ROWS = SHOULDER SHAPING); 5 sts. after Row 429 (ODD ROWS = NECK SHAPING); 2 sts. after Row 430; 5 sts. after Row 431; 2 sts. after Row 432; 3 sts. after Row 433; 2 sts. after Row 434; 3 sts. after Row 435; 2 sts. after Rows 436, 437, 438, 439, 440; 3 sts. after Rows 442, 444, 446, 448.

ON CAM BOX SIDE, bind off 4 sts. after Rows 288, 289; 3 sts. after Rows 292, 293, 296, 297; 2 sts. after Rows 300, 301, 304, 305; 1 st. after Rows 308, 309, 312, 313, 316, 317, then knit to Row 428, bind off the center 19 sts., put the needles on the left side into holding position and complete the right half first.

ON EACH SIDE, increase 1 st. after Rows 168, 192, 216, 240, 264, then knit to Row 288.

ON EACH SIDE, decrease 1 st. after Rows 42, 54, 66, 78, 90, 100, 110, 120, 130, 140, then knit to Row 168.

ROWS 15 to 42: Knit even.

ROWS 0 to 14: Knit even, then begin the Weaving Design.

Cast on 155 sts. with color 1 and work stockinette st.

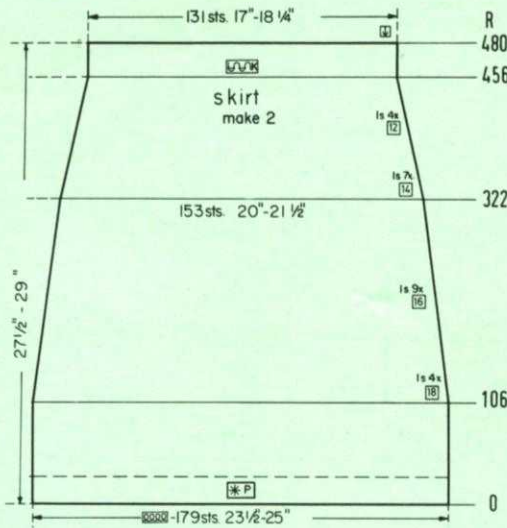

Work the second skirt section the same.

ON EACH SIDE, decrease 1 st. after Rows 106, 124, 142, 160, 178, 194, 210, 226, 242, 258, 274, 290, 306, 322, 336, 350, 364, 378, 392, 406, 420, 432, 444, 456, but do not knit after the last decrease. Change to stockinette st. and with color 1 knit to Row 480, then bind off the remaining 131 sts.

ROWS 0 to 106: Knit even.

Cast on 179 sts. and work the Weaving Design.



Cast on 151 sts. with color 1 and work 14 rows stockinette st., then bind off all sts.

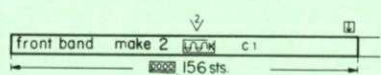

Cast on 156 sts. with color 1 and work 14 rows stockinette st., then bind off all sts.

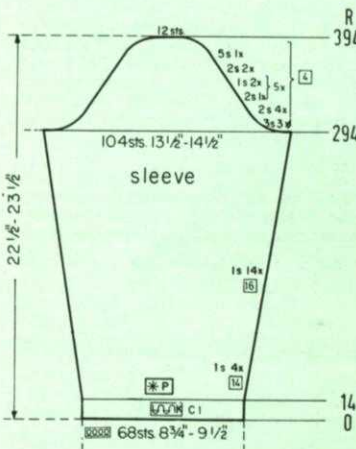

ON CAM BOX SIDE, bind off 3 sts. after Rows 294, 295, 298, 299, 302, 303; 2 sts. after Rows 306, 307, 310, 311, 314, 315, 318, 319; 1 st. after Rows 322, 323, 326, 327; 2 sts. after Rows 330, 331; 1 st. after Rows 334, 335, 338, 339; 2 sts. after Rows 342, 343; 1 st. after Rows 346, 347, 350, 351; 2 sts. after Rows 354, 355; 1 st. after Rows 358, 359, 362, 363; 2 sts. after Rows 366, 367; 1 st. after Rows 370, 371, 374, 375; 2 sts. after Rows 378, 379, 382, 383, 386, 387; 5 sts. after Rows 390, 381; 12 sts. after Row 394.

ON EACH SIDE, increase 1 st. after Rows 14, 28, 42, 56, 70, 86, 102, 118, 134, 150, 166, 182, 198, 214, 230, 246, 262, 278, then knit to Row 294.

ROWS 0 to 14: Knit even, then begin the Weaving Design.

Cast on 68 sts. with color 1 and work stockinette st.

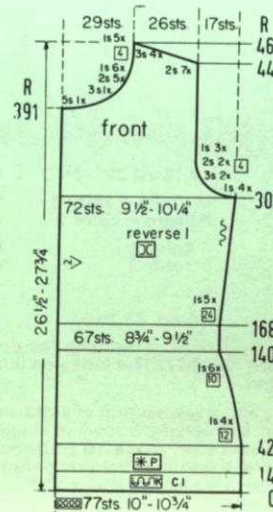

Work the second section with reverse shapings. Cast on the regular way, knit the 14 rows stockinette st. with color 1, then begin the Weaving Pattern. Knit 1 row to the left side, turn the Row Counter back to 14 and follow the instructions as written. (The Cam Box will be on the LEFT side at even numbered rows).

ON CAM BOX SIDE, bind off 5 sts. after Row 391; 3 sts. after Row 393; 2 sts. after Rows 395, 397, 399, 401, 403; 1 st. after Rows 405, 407, 409, 411, 413, 415, 417, 421, 425, 429, 433. For SHOULDER bind off 2 sts. after Rows 442, 444, 446, 448, 450, 452, 454; 3 sts. after Rows 456, 458, 460, 462.

ON CAM BOX SIDE, bind off 4 sts. after Row 302; 3 sts. after Rows 306, 310; 2 sts. after Rows 314, 318; 1 st. after Rows 322, 326, 330, then knit to Row 391.

ON CAM BOX SIDE, increase 1 st. after Rows 168, 192, 216, 240, 264, then knit to Row 302.

ON CAM BOX SIDE, decrease 1 st. after Rows 42, 54, 66, 78, 90, 100, 110, 120, 130, 140, then knit to Row 168.

ROWS 15 to 42: Knit even.

ROWS 0 to 14: Knit even, then begin the Weaving Design.

Cast on 77 sts. with color 1 and work stockinette st.

BE SURE TO NOTIFY US IMMEDIATELY OF ANY CHANGE OF ADDRESS. THE POST OFFICE WILL NOT FORWARD YOUR MAGAZINE TO YOU.

DKS185

SIZE:	8 (Bust 31"-32")	12 (Bust 33"-34")
YARN:	Amore	Alanda
50 gr. BALLS:		
PANTS:	10 color 1	15 color 1
TOP & CAP:	3 color 1	5 color 1
	2 color 2	3 color 2
TENSION:	7 to 9	7 to 9
GAUGE:	2" 15 sts. 23 rows	14 sts. 21 rows



The instructions are the same for both sizes. **PATTERN:** Stockinette Stitch with repeated color stripes as marked in the Diagrams. **EDGES and CAP:** K1, P1, Ribbing. **DECREASES:** Hang the 3rd st. onto the 2nd st., then move the end sts. inward to fill the empty needle. **INCREASES:** Move the 2 end sts. 1 needle outward, then place the 3rd st. from the row below onto the empty needle.

FINISHING: Block all sections. **PANTS:** Join front and back sections at sides. Sew the inner leg seams together. On the wrong side, attach 4" wide press-on type pelon to the lower edges, then turn under 2" to wrong side and hem in place. Separate the 2 layers on the hems and fold up, having the hem seam line at the center of the hem on the wrong side. Press, then fasten the cuffs at the side seams. Join the sections at center back and center front. Turn under 14 rows on the upper edge and hem. Insert an elastic band into the hem. **TOP:** Join front and back section at sides and shoulders. Join the short ends of the armhole bands and sew them in place. Join the neckband sections then sew to neckline. **CAP:** Weave the section together at center back. Pull the strands of yarn - holding the open sts. - tightly together and sew in the ends.

Move the Cam Box to the left side, turn the Row Counter back to 166 and complete the left half. Follow the instructions from*.

Continue to decrease 1 st. ON NECK SIDE after Rows in (). ON CAM BOX SIDE, bind off 3 sts. after Rows 230, (230), 232, 234, (234), 236, 238, (238), 240, 242, (242), 244, 246; (246), 4 sts. after Rows 248, 250, (250), 252, 254; (254). 5 sts. after Rows 256, 258, (258), 260, 262.

*Cast on 7 sts. ON CAM BOX SIDE. ON OPPOSITE SIDE of CAM BOX (NECK SIDE), decrease 1 st. after Rows 166, 168, 170, 172, 174, then again after Rows in (). ON CAM BOX SIDE, increase 1 st. after Rows 176, (176), (178), 180, (182), 184, (186), 188, (190), 192, (194), 196, (198), 200, (202), 204, (206), 208, 210, (210), 212, 214, (214), 216, 218, (218), 220, 222, (222), 224, 226, (226), then knit to Row 230.

Work the front section the same as the back section to ROW 166, then put 65 needles on the left side into holding position and complete the right half first.

Move the Cam Box to the left side, turn the Row Counter back to 244 and complete the left half. Follow the instructions from*.

*ON CAM BOX SIDE, bind off 3 sts. after Rows 244 (EVEN ROWS = SHOULDER SHAPING), 245 (ODD ROWS = NECK SHAPING), 246, 247; 4 sts. after Row 248; 2 sts. after Row 249; 4 sts. after Row 250; 2 sts. after Row 251; 4 sts. after Row 252; 1 st. after Row 253; 4 sts. after Row 254; 1 st. after Row 255; 5 sts. after Row 256; 1 st. after Row 257; 5 sts. after Row 258; 1 st. after Row 259; 5 sts. after Rows 260, 262.

ON CAM BOX SIDE, bind off 3 sts. after Rows 230, 231, 232, 233, 234, 235, 236, 237, 238, 239, 240, 241, 242, 243, then knit to Row 244, bind off the center 26 sts., put the needles on the left side into holding position and complete the right half first.

ON EACH SIDE, increase 1 st. after Rows 176, 180, 184, 188, 192, 196, 200, 204, 208, 210, 212, 214, 216, 218, 220, 222, 224, 226, then knit to Row 230.

ON EACH SIDE, increase 1 st. after Rows 74, 86, 98, 110, 122, 134, 146, 156, then knit to Row 166. ON EACH SIDE, cast on 7 sts. (use a separate length of yarn for the left side), then knit to Row 176. (For the Front Section knit to ROW 166).

ROWS 33 to 74: Knit even.

ROWS 0 to 32: Knit even, then change to stockinette st. and work the repeated color stripes as marked in the Diagram.

Cast on 114 sts. with color 1 and work K1, P1, Ribbing.

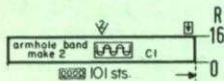

Cast on 101 sts. with color 1 and work 12 rows K1, P1, Ribbing, the bind off all sts.

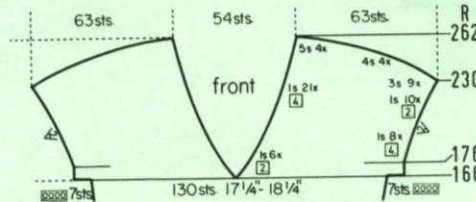

Cast on 131 sts. with color 1, work K1, P1, Ribbing and the color stripes as marked in the Diagram. After Row 98 remove the sts. from the machine by transferring first the 1st, 3rd, 5th, 7th, etc. sts. onto a length of yarn and then the 2nd, 4th, 6th, etc. sts. onto a separate length of yarn. (Use a ribber transfer needle).

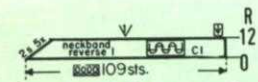
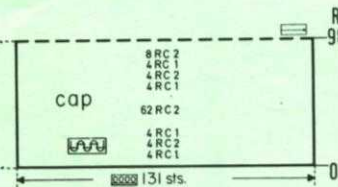

Cast on 109 sts. and work K1, P1, Ribbing. Decrease 2 sts. ON OPPOSITE SIDE of CAM BOX after Rows 2, 4, 6, 8, 10. After Row 12 bind off all sts. Work the second band section with reverse shapings, casting on from right to left. (Cam Box will be on the LEFT side at Row 0). See the News Letter for Practical Hint.

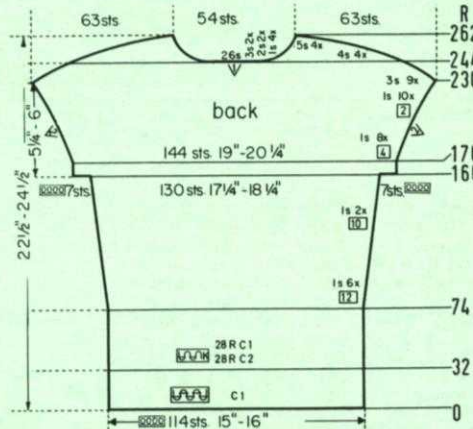

DKS166

SIZE:	8 (Bust 31"-32")	12 (Bust 33"-34")	14 (Bust 35"-36")
YARN:	Melodie = color 1 Allegro = color 2	Melodie = color 1 Allegro = color 2	Melodie = color 1 Allegro = color 2
50 gr. BALLS:	8 color 1 3 color 2	8 color 1 3 color 2	9 color 1 4 color 2
TENSION:	5 to 7	6 to 8	7 to 9
GAUGE:	2" 15 sts. 43 rows	14 sts. 41 rows	13 sts. 39 rows

The instructions are the same for all sizes. **PATTERN:** Holding Position Design according to the Line Drawing, or use JAC 40 and Pattern No. 447. The knit side is the right side. Make all shapings on the outer edges. **EDGES:** Crochet.

FINISHING: Block all sections. Join front and back section at sides and shoulders. Sew the sleeves together and set in. For the crochet trim, work 3 rows of single crochet and 1 row of picots around all edges. While working the 2nd row, make 10 buttonholes on the right front edge. Chain 2 and skip 2 for each buttonhole. Begin the first buttonhole about 3/4" from the lower edge of the opening. The following buttonholes are about 1 1/4" apart. (Mark buttonhole space for correct spacing). Sew buttons in place.

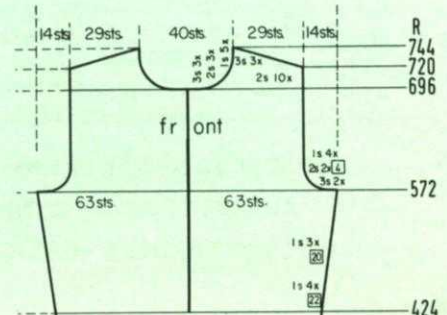

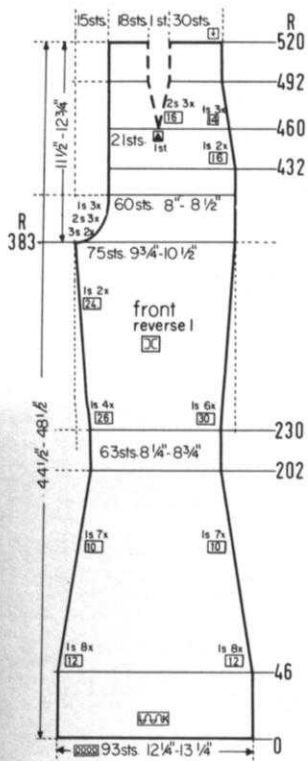

Work the second front section with reverse shapings, casting on from right to left. (Cam Box will be on the LEFT side at Row 0).

Decrease 2 sts. for the DART after Rows in (). ON CAM BOX SIDE, decrease 1 st. after Rows 432, 448, (460), 464, (476), 478, 492, (492), then knit to Row 520 and bind off the remaining 49 sts.

ON CAM BOX SIDE, bind off 3 sts. after Rows 383, 385; 2 sts. after Rows 387, 389, 391; 1 st. after Rows 393, 395, 397, then knit to Row 432.

ON OPPOSITE SIDE OF CAM BOX increase 1 st. after Rows in (). ON CAM BOX SIDE, increase 1 st. after Rows 230, (230), (256), 260, (282), 290, (308), 320, (334), 350, (358), 380, then knit to Row 383.

ON EACH SIDE, decrease 1 st. after Rows 46, 58, 70, 82, 94, 106, 118, 130, 142, 152, 162, 172, 182, 192, 202, then knit to Row 230.

ROWS 0 to 46: Knit even.

Cast on 93 sts. and work stockinette st.

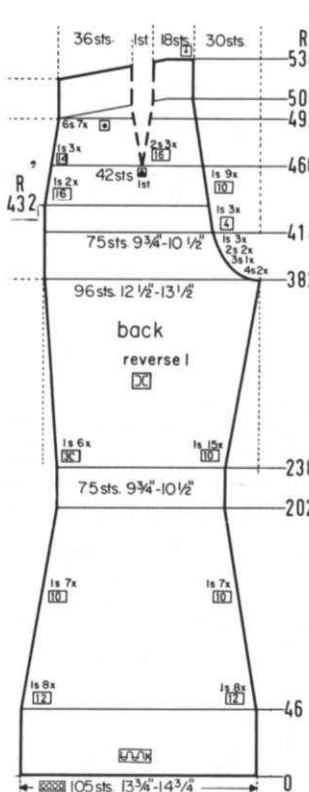

Work the second back section with reverse shapings, casting on from right to left. (Cam Box will be on the LEFT side at Row 0).

Decrease 1 st. ON OPPOSITE SIDE of CAM BOX after Row 432, then again after Rows in (). Decrease 2 sts. for the DART after (DART). Continue to decrease 1 st. ON CAM BOX SIDE after Rows 440, (448), 450, 460, (DART 460), (464), 470, (DART 476), (478), 480, 490, (492), (DART 492), but do not knit after the last decreases. Work Short Rows. ON OPPOSITE SIDE of CAM BOX put into holding position 6 needles after Rows 492, 494, 496, 498, 500, 502, 504. After Row 506 bring all needles back into working position, then knit to Row 534 and bind off the remaining 55 sts.

ON CAM BOX SIDE, bind off 4 sts. after Rows 382, 384; 3 sts. after Row 386; 2 sts. after Rows 388, 390; 1 st. after Rows 392, 394, 396, 398, 402, 406, 410, 420, 430, then knit to Row 432.

ON OPPOSITE SIDE of CAM BOX increase 1 st. after Rows in (). ON CAM BOX SIDE, increase 1 st. after Rows 230, (230), 240, 250, 260, (260), 270, 280, 290, (290), 300, 310, 320, (320), 330, 340, 350, (350), 360, 370, (380), then knit to Row 382.

ON EACH SIDE, decrease 1 st. after Rows 46, 58, 70, 82, 94, 106, 118, 130, 142, 152, 162, 172, 182, 192, 202, then knit to Row 230.

ROWS 0 to 46: Knit even.

Cast on 105 sts. and work stockinette st.

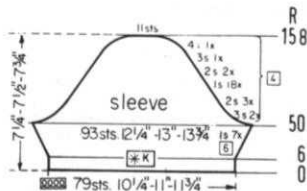
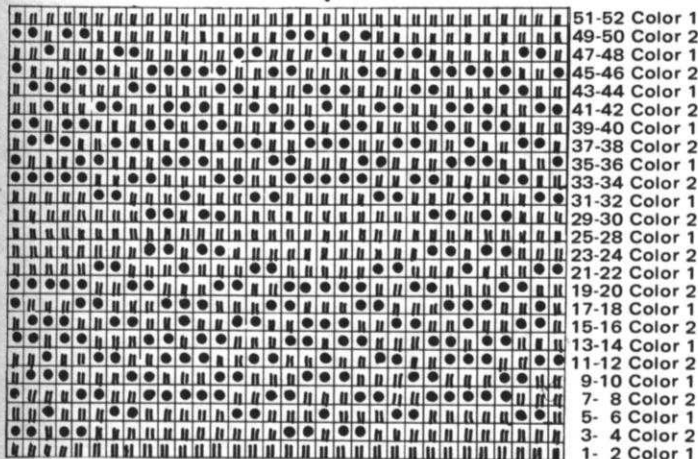

ON CAM BOX SIDE, bind off 3 sts. after Rows 50, 51, 54, 55; 2 sts. after Rows 58, 59, 62, 63, 66, 67. ON EACH SIDE, hang the 1st st. onto the 2nd st. after Rows 70, 74, 78, 82, 86, 90, 94, 98, 102, 106, 110, 114, 118, 122, 126, 130, 134, 138. ON CAM BOX SIDE, bind off 2 sts. after Rows 142, 143, 146, 147; 3 sts. after Rows 150, 151; 4 sts. after Rows 154, 155; 11 sts. after Row 158.

ON EACH SIDE, increase 1 st. after Rows 6, 12, 18, 24, 30, 36, 42, then knit to Row 50.

ROWS 0 to 6: Knit even.

Cast on 79 sts. with color 1 and work the Holding Position Design.

Continued on page 15

Bring the needles on the left side into working position, knit 1 row in PATTERN to the left side, turn the Row Counter back to 424 and complete the left half. Follow the instructions from*.

ON CAM BOX SIDE, bind off 3 sts. after Rows 697, 699, 701; 2 sts. after Rows 703, 705, 707; 1 st. after Rows 709, 711, 713, 715, 717. For SHOULDER bind off 2 sts. after Rows 720, 722, 724, 726, 728, 730, 732, 734, 736, 738; 3 sts. after Rows 740, 742, 744.

ON CAM BOX SIDE, bind off 3 sts. after Rows 572, 576; 2 sts. after Rows 580, 584; 1 st. after Rows 488, 492, 596, 600, then knit to Row 697.

*ON CAM BOX SIDE, increase 1 st. after Rows 424, 446, 468, 490, 512, 532, 552, then knit to Row 572.

Work the front section the same as the back section to ROW 424, then put 56 needles on the left side into holding position and complete the right half first.

Jac40 is a must!

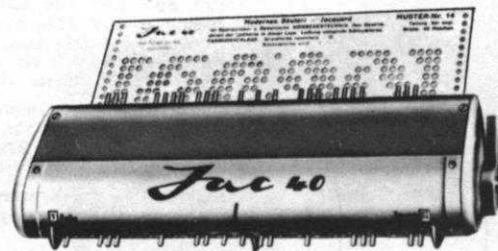

DKS167

SIZE: 12 (Bust 33"-34") 14 (Bust 36"-37")
YARN: Regia = Main Yarn Regia = Main Yarn
 Beatrice = Contrast Yarn Beatrice = Contrast Yarn

50 gr. BALLS:
PANTS: 9 color 1 (Main Yarn) 10 color 1 (Main Yarn)
JACKET: 9 color 1 (Main Yarn) 10 Color 1 (Main Yarn)
 1 color 2 1 color 2
 1 color 3 1 color 3
 1 color 4 1 color 4
 1 color 5 1 color 5

TENSION: Stk: 4 to 6 5 to 7
 Pattern: 8 to 9 9 to 10
GAUGE: 2" Stk: 18 sts. 25 rows 17 sts. 24 rows
 Pattern: 14 sts. 44 rows 13 sts. 42 rows



The instructions are the same for both sizes. **PATTERN:** Stockinette Stitch, worn on the knit side. **JACKET:** Holding Position Design according to the Line Drawing, using Wheel No. 6. The purl side is the right side. **EDGES:** Stockinette st. with repeated color stripes as marked in the Diagrams. The knit side is the right side. **PANTS:** DECREASES: Hang the 3rd st. onto the 2nd st., then move the end sts. inward to fill the empty needles. **INCREASES:** Move the 2 end sts. 1 needle outward, then place the 3rd st. from the row below onto the empty needle. Make the shapings on the sleeves on the outer edges.

FINISHING: Block all sections. **PANTS:** Join the sections at sides. Sew the inner leg seams together. Join the sections at center front and at center back. Turn under 19 rows on leg edges and 14 rows on upper edge and hem in place. Insert an elastic band into the upper hem. **JACKET:** Join the back and front sections at sides and shoulders, easing in the fullness at bustline of the front sections. Sew the sleeves together and set in. Turn over 36 rows on the sleeve edges and on the lower edge and hem to right side. Turn under 11 sts. on the front edges and hem in place. Sew 1 edge of the neckband to inside and 1 edge to outside of neckline. Finish the buttonholes, sew on buttons.

Work the right front section with reversed shapings. Cast on the regular way. Work stockinette st., the color stripes and make buttonholes after Rows 6, 24, 48, 66 over the 5th-9th sts. counting from the right side. The band is completed after Row 72. Now change to color 1 and knit 1 row in PATTERN to the left side, then cast on 11 sts. ON CAM BOX SIDE. Turn the Row Counter back to 72. (The Cam Box will be on the LEFT side at even numbered rows). Make buttonholes after Rows 138, 209, 280, 351 over the 3rd-7th and 16th-20th sts. counting from the right side.

ON CAM BOX SIDE, bind off 21 sts. after Row 433; 3 sts. after Rows 437, 441; 2 sts. after Rows 445, 449; 1 st. after Rows 453, 457, 461, 465. For SHOULDER bind off 2 sts. after Rows 474, 476, 478, 480, 482, 484, 486, 488, 490, 492, 494, 496, 498, 500.

ON CAM BOX SIDE, bind off 4 sts. after Row 314; 3 sts. after Row 318; 2 sts. after Rows 322, 326, 330; 1 st. after Rows 334, 338, 342, then knit to Row 433.

ROWS 73 to 314: Knit even.
 ROWS 0 to 72: Knit even, then change to color 1, cast on 11 sts. ON OPPOSITE SIDE of CAM BOX (use a separate length of yarn) and begin the Holding Position Design.

Cast on 68 sts. with color 2, work stockinette st. and the color stripes as marked in the Diagram.

Do NOT make buttonholes in the left front section.

ON CAM BOX SIDE, bind off 3 sts. after Rows 382, 383, 386, 387; 2 sts. after Rows 390, 391, 394, 395, 398, 399. ON EACH SIDE, decrease 1 st. after Rows 402, 406, 410, 414, 418, 422, 426, 430, 434, 438, 442, 446, 450, 454, 458, 462, 466, 470, 474, 478. ON CAM BOX SIDE, bind off 2 sts. after Rows 482, 483; 3 sts. after Rows 486, 487, 490, 491; 13 sts. after Row 494.

ON EACH SIDE, increase 1 st. after Rows 72, 90, 108, 126, 144, 162, 180, 198, 216, 234, 252, 270, 286, 302, 318, 334, 350, 366, then knit to Row 382.

ROWS 0 to 72: Knit even, then change to color 1 and begin the Holding Position Design.

Cast on 57 sts. with color 2, work stockinette st. and the color stripes as marked in the Diagram.

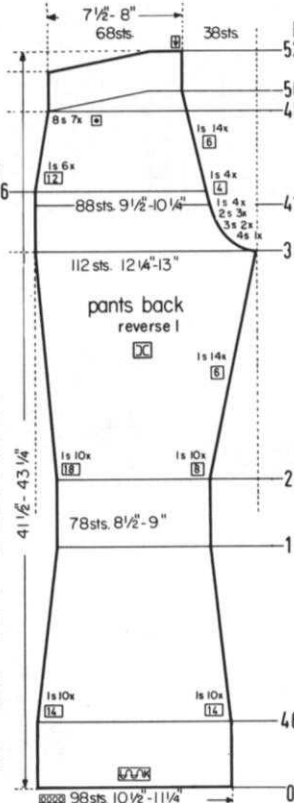
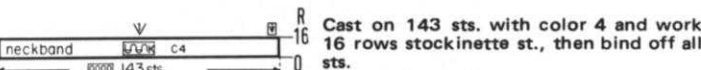
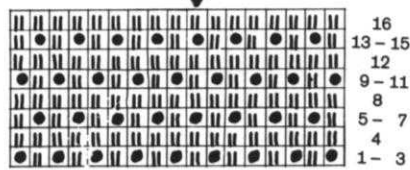
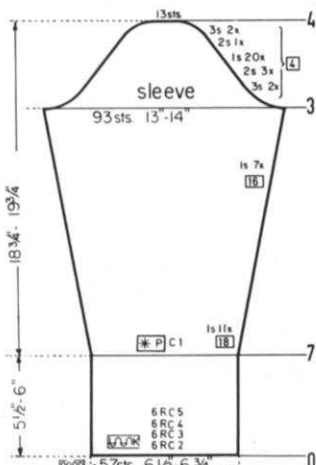
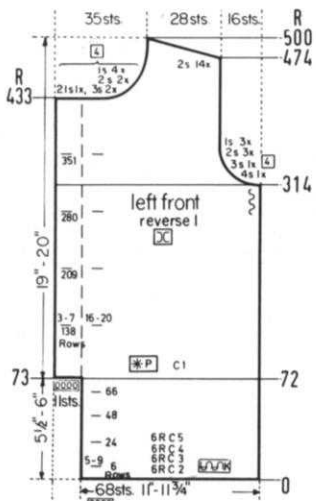
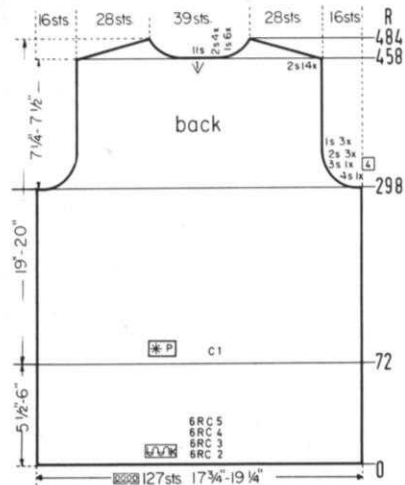

Cast on 143 sts. with color 4 and work 16 rows stockinette st., then bind off all sts.

Work the second back section with reverse shapings, casting on from right to left. (Cam Box will be on the left side at Row 0).

ON OPPOSITE SIDE of CAM BOX decrease 1 st. after Rows in (). ON CAM BOX SIDE, bind off 4 sts. after Row 384; 3 sts. after Rows 386, 388; 2 sts. after Rows 390, 392, 394; 1 st. after Rows 396, 398, 400, 402, 404, 408, 412, 416, 420, 426, (426), 432, 438, (438), 444, 450, (450), 456, 462, (462), 468, 474, (474), 480, 486, but do not knit after the last decreases. Continue to decrease 1 st. ON CAM BOX SIDE after Rows in (). Work Short Rows. ON OPPOSITE SIDE of CAM BOX put into holding position 8 needles after Rows 486, 488, 490, 492, (492), 494, 496, 498, (498). After Row 500 bring all needles back into working position, then knit to Row 528 and bind off the remaining 68 sts.

ON OPPOSITE SIDE of CAM BOX increase 1 st. after Rows in (). ON CAM BOX SIDE, increase 1 st. after Rows 220, (220), 228, 236, (238), 244, 252, (256), 260, 268, (274), 276, 284, 292, (292), 300, 306, (310), 312, 318, 324, (328), 330, 336, 342, (346), 348, 354, 360, (364), 366, 372, 378, (382), then knit to Row 384.

ON EACH SIDE, decrease 1 st. after Rows 46, 60, 74, 88, 102, 116, 130, 144, 158, 172, then knit to Row 220.

ROWS 0 to 46: Knit even.

Cast on 98 sts. and work stockinette st.

Bring the needles on the left side into working position, knit 1 row in PATTERN to the left side, turn the Row Counter back to 458 and complete the left half. Follow the instructions from*.

*ON CAM BOX SIDE, bind off 2 sts. after Rows 458 (EVEN ROWS = SHOULDER SHAPING), 459 (ODD ROWS = NECK SHAPING), 460, 461, 462, 463, 464, 465, 466; 1 st. after Row 467; 2 sts. after Row 468; 1 st. after Row 469; 2 sts. after Row 470; 1 st. after Row 471; 2 sts. after Row 472; 1 st. after Row 473; 2 sts. after Row 474; 1 st. after Row 475; 2 sts. after Row 476; 1 st. after Row 477; 2 sts. after Rows 478, 480, 482, 484.

ON CAM BOX SIDE, bind off 4 sts after Rows 298, 299; 3 sts. after Row 302, 303; 2 sts. after Rows 306, 307, 310, 311, 314, 315; 1 st. after Rows 318, 319, 322, 323, 326, 327, then knit to Row 458, bind off the center 11 sts., put the needles on the left side into holding position and complete the right half first.

ROWS 73 to 298: Knit even.

ROWS 0 to 72: Knit even, then change to color 1 and begin the Holding Position Design.

Cast on 127 sts. with color 2, work stockinette st. and the color stripes as marked in the Diagram.

DK 8166

Continued from page 13

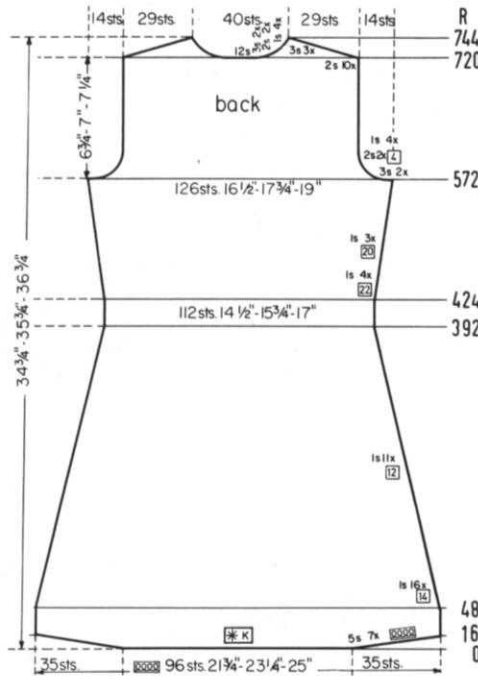

Bring the needles on the left side into working position, knit 1 row in PATTERN to the left side, turn the Row Counter back to 720 and complete the left half. Follow the instructions from*.

*ON CAM BOX SIDE, bind off 2 sts. after Row 720 (EVEN ROWS = SHOULDER SHAPING); 3 sts. after Row 721 (ODD ROWS = NECK SHAPING); 2 sts. after Row 722; 3 sts. after Row 723; 2 sts. after Rows 724, 725, 726, 727, 728; 1 st. after Row 729; 2 sts. after Row 730; 1 st. after Row 731; 2 sts. after Row 732; 1 st. after Row 733; 2 sts. after Row 734; 1 st. after Row 735; 2 sts. after Rows 736, 738; 3 sts. after Rows 740, 742, 744.

ON CAM BOX SIDE, bind off 3 sts. after Rows 572, 573, 576, 577; 2 sts. after Rows 580, 581, 584, 585; 1 st. after Rows 588, 589, 592, 593, 596, 597, 600, 601, then knit to Row 720, bind off the center 12 sts., put the needles on the left side into holding position and complete the right half first.

ON EACH SIDE, increase 1 st. after Rows 424, 446, 468, 490, 512, 532, 552, then knit to Row 572.

ON EACH SIDE, decrease 1 st. after Rows 48, 62, 76, 90, 104, 118, 132, 146, 160, 174, 188, 202, 216, 230, 244, 258, 272, 284, 296, 308, 320, 332, 344, 356, 368, 380, 392, then knit to Row 424. (For the Front Section knit to Row 424).

ON CAM BOX SIDE, cast on 5 sts. after Rows 2, 3, 4, 5, 6, 7, 8, 9, 10, 11, 12, 13, 14, 15, then knit to Row 48.

Cast on 96 sts. with color 1 and work the Holding Position Design.

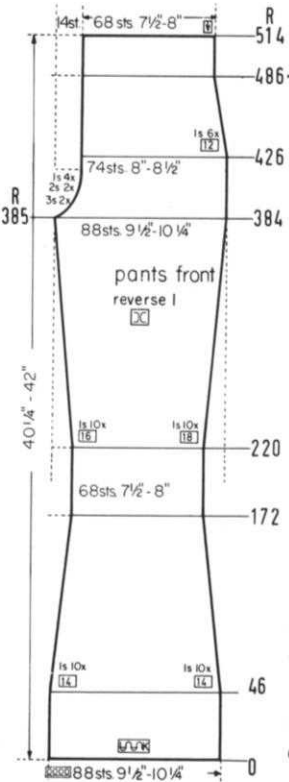

Work the second front section with reverse shapings, casting on from right to left. (Cam Box will be on the LEFT side at Row 0).

ON CAM BOX SIDE, decrease 1 st. after Rows 426, 438, 450, 462, 474, 486, then knit to Row 514 and bind off the remaining 68 sts.

ON CAM BOX SIDE, bind off 3 sts. after Rows 385, 387; 2 sts. after Rows 389, 391; 1 st. after Rows 393, 395, 397, 399, then knit to Row 426.

ON OPPOSITE SIDE of CAM BOX increase 1 st. after Rows in (). ON CAM BOX SIDE, increase 1 st. after Rows 220, (220), (236), 238, (252), 256, (268), 274, (284), 292, (300), 310, (316), 328, (332), 346, (348), 364, (364), 382, then knit to Row 385.

ON EACH SIDE, decrease 1 st. after Rows 46, 60, 74, 88, 102, 116, 130, 144, 158, 172, then knit to Row 220.

ROWS 0 to 46: Knit even.

Cast on 88 sts. and work stockinette st.

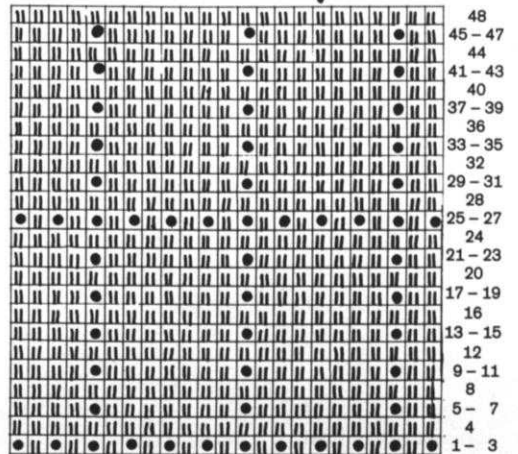

HP3693

SIZE:	38 (Chest 37"-38")	40 (Chest 40-41")	44 (Chest 43"-44")
YARN:	Melodie	Melodie	Melodie
50 gr. BALLS:	9	9	10
TENSION:	Pattern: 6 to 8 K1, P1: 4 to 6	7 to 9 5 to 7	8 to 10 6 to 8
GAUGE:	2" 15 sts. 28 rows	14 sts. 27 rows	13 sts. 26 rows

The instructions are the same for all sizes. PATTERN: Holding Position Design according to the Line Drawing. Use the adjustable needle selector. For Rows 1, 25, 50, etc. use Wheel No. 6. The purl side is the right side. EDGES: K1, P1, Ribbing. Make the increases for the sleeves on the outer edges.

FINISHING: Block all sections. Join front and back section at sides and shoulders. Sew the sleeves together and set in. Sew the buttonhole band and the button band in place. Sew the neckband to neckline, leaving a space on the left side for a buttonhole. Finish the buttonholes, sew on buttons.



continued on page 16

Continued from page 15

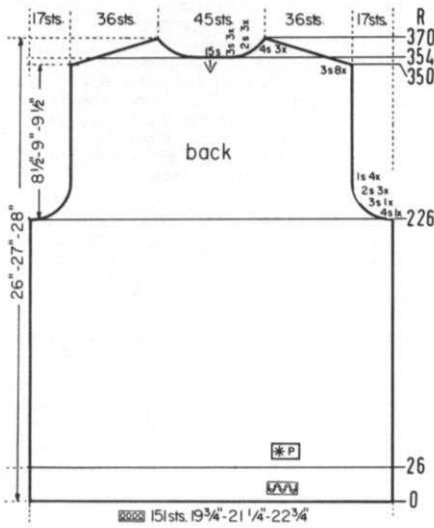

Bring the needles on the left side into working position, knit 1 row in PATTERN to the left side, turn the Row Counter back to 354 and complete the left half. Follow the instructions from*.

*ON CAM BOX SIDE, bind off 3 sts. after Rows 354 (EVEN ROWS = SHOULDER SHAPING), 355 (ODD ROWS = NECK SHAPING), 356, 357, 358, 359, 360; 2 sts. after Row 361; 3 sts. after Row 362; 2 sts. after Row 363; 3 sts. after Row 364; 2 sts. after Row 365; 4 sts. after Rows 366, 368, 370.

ON CAM BOX SIDE, bind off 3 sts. after Rows 350, 351, 352, 353, then knit to Row 354, bind off the center 15 sts., put the needles on the left side into holding position and complete the right half first.

ON CAM BOX SIDE, bind off 4 sts. after Rows 226, 227; 3 sts. after Rows 228, 229; 2 sts. after Rows 230, 231, 232, 233, 234, 235; 1 st. after Rows 236, 237, 238, 239, 240, 241, 242, 243, then knit to Row 350.

ROWS 27 to 226: Knit even. (For the Front Section knit to ROW 200).

ROWS 0 to 26: Knit even, then change to stockinette st. and work the Holding Position Design.

Cast on 151 sts. and work K1, P1, Ribbing.

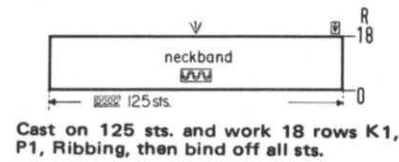

Cast on 125 sts. and work 18 rows K1, P1, Ribbing, then bind off all sts.

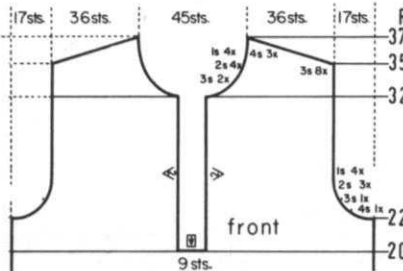

Bring the needles on the left side into working position, knit 1 row in PATTERN to the left side, turn the Row Counter back to 200 and complete the left half. Follow the instructions from*.

ON CAM BOX SIDE, bind off 3 sts. after Rows 325, 327; 2 sts. after Rows 329, 331, 333, 335; 1 st. after Rows 337, 339, 341, 343. For SHOULDER bind off 3 sts. after Rows 350, 352, 354, 356, 358, 360, 362, 364; 4 sts. after Rows 366, 368, 370.

ON CAM BOX SIDE, bind off 4 sts. after Row 226; 3 sts. after Row 228; 2 sts. after Rows 230, 232, 234; 1 st. after Rows 236, 238, 240, 242, then knit to Row 325.

*ROWS 201 to 226: Knit even.

Work the front section the same as the back section to ROW 200, then bind off the center 9 sts., put the needles on the left side into holding position and complete the right half first.

Cast on 67 sts. and work K1, P1, Ribbing. Make buttonholes after Rows 4 and 14 over the 14th-17th, 32nd-35th and 50th-53rd sts. counting from the left side. After Row 18 bind off all sts. Work the button band the same, but omit the buttonholes.

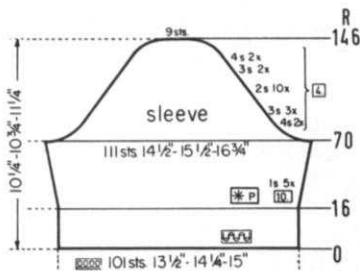
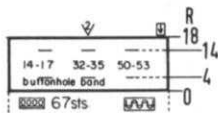

ON CAM BOX SIDE, bind off 4 sts. after Rows 70, 71, 74, 75; 3 sts. after Rows 78, 79, 82, 83, 86, 87; 2 sts. after Rows 90, 91, 94, 95, 98, 99, 102, 103, 106, 107, 110, 111, 114, 115, 118, 119, 122, 123, 126, 127; 3 sts. after Rows 130, 131, 134, 135; 4 sts. after Rows 138, 139, 142, 143; 9 sts. after Row 146.

ON EACH SIDE, increase 1 st. after Rows 16, 26, 36, 46, 56, then knit to Row 70.

ROWS 0 to 16: Knit even, then change to stockinette st. and work the Holding Position Design.

Cast on 101 sts. and work K1, P1, Ribbing.

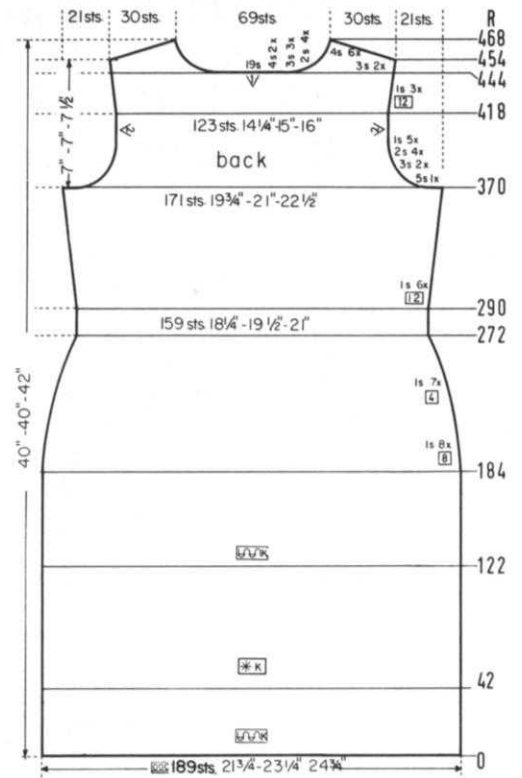

Cast on 129 sts. and work 10 rows stockinette st., then bind off all sts.

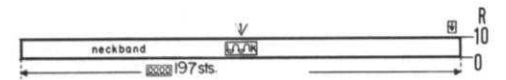

Cast on 197 sts. and work 10 rows stockinette st., then bind off all sts.

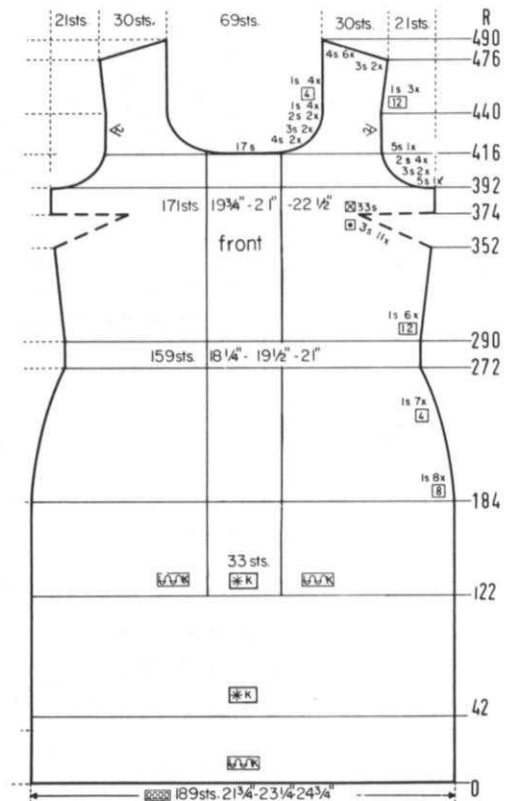

Move the Cam Box to the left side, turn the Row Counter back to 444 and complete the left half. Follow the instructions from*.

*ON CAM BOX SIDE, bind off 4 sts. after Rows 445, 447 (ODD ROWS = NECK SHAPING); 3 sts. after Rows 449, 451, 453, 454 (EVEN ROWS = SHOULDER SHAPING); 2 sts. after Row 455; 3 sts. after Row 456; 2 sts. after Row 457; 4 sts. after Row 458; 2 sts. after Row 459; 4 sts. after Row 460; 2 sts. after Row 461; 4 sts. after Rows 462, 464, 466, 468.

ON EACH SIDE, increase 1 st. after Rows 418, 430, 442. After Row 444 bind off the center 19 sts., put the needles on the left side into holding position and complete the right half first.

ON CAM BOX SIDE, bind off 5 sts. after Rows 370, 371; 3 sts. after Rows 372, 373, 374, 375; 2 sts. after Rows 376, 377, 378, 379, 380, 381, 382, 383; 1 st. after Rows 384, 385, 386, 387, 388, 389, 390, 391, 392, 393, then knit to Row 418.

ON EACH SIDE, increase 1 st. after Rows 290, 302, 314, 326, 338, 350, then knit to Row 370.

ON EACH SIDE, decrease 1 st. after Rows 184, 192, 200, 208, 216, 224, 232, 240, 248, 252, 256, 260, 264, 268, 272, then knit to Row 290.

ROWS 123 to 184: Knit even.

ROWS 43 to 122: Knit even, then continue with stockinette st.

ROWS 0 to 42: Knit even, then begin the Eyelet Design.

Cast on 189 sts. and work stockinette st.

Move the Cam Box to the left side turn the Row Counter back to 416 and complete the left half. Follow the instructions from*.

*ON ARMHOLE SIDE increase 1 st. after Rows in (). ON CAM BOX SIDE, bind off 4 sts. after Rows 417, 419; 3 sts. after Rows 421, 423; 2 sts. after Rows 425, 427; 1 st. after Rows 429, 431, 433, 435, 437, (440), 441, 445, 449, (452), (464). For SHOULDER bind off 3 sts. after Rows 476, 478; 4 sts. after Rows 480, 482, 484, 486, 488, 490.

ON CAM BOX SIDE, bind off 5 sts. after Rows 392, 393; 3 sts. after Rows 394, 395, 396, 397; 2 sts. after Rows 398, 399, 400, 401, 402, 403, 404, 405; 1 st. after Rows 406, 407, 408, 409, 410, 411, 412, 413, 414, 415, then knit to Row 416, bind off the center 17 sts., put the needles on the left side into holding position and complete the right half first.

ON EACH SIDE, increase 1 st. after Rows 290, 302, 314, 326, 338, 350, then knit to Row 352 and work Short Rows for the DARTS. ON OPPOSITE SIDE of CAM BOX put into holding position 3 needles after Rows 352, 353, 354, 355, 356, 357, 358, 359, 360, 361, 362, 363, 364, 365, 366, 367, 368, 369, 370, 371, 372, 373. ON OPPOSITE SIDE of CAM BOX bring all needles back into working position after Rows 374, 375, then knit to Row 392.

ON EACH SIDE, decrease 1 st. after Rows 184, 192, 200, 208, 216, 224, 232, 240, 248, 252, 256, 260, 264, 268, 272, then knit to Row 290.

ROWS 123 to 184: Knit even.

ROWS 43 to 122: Knit even, then begin the Eyelet Design over the center 33 sts.

ROWS 0 to 42: Knit even, then begin the Eyelet Design.

Cast on 189 sts. and work stockinette st.

DK 8170

SIZE:	16 (Bust 37"-38")	18 (Bust 39"-40")	20 (Bust 42"-43")
YARN:	Beatrice Crepe	Regia	Regia
50 gr. BALLS:	13	13	14
TENSION:	4 to 6	5 to 7	6 to 8
GAUGE:	2" 17 sts. 23 rows	16 sts. 23 rows	15 sts. 22 rows

The instructions are the same for all sizes. PATTERN: Stockinette st. with Eyelet Design according to the Line Drawing. The Back Section has the Eyelet Design around the lower edge, the Front Section has the Design around the lower edge and center front. DECREASES: Hang the 3rd st. onto the 2nd st., then move the end sts. inward to fill the empty needle. INCREASES: Move the 2 end sts. 1 needle outward, then place the 3rd st. from the row below onto the empty needle.

FINISHING: Block the sections. Join the front and back section at sides and shoulders. Join the short ends of the armhole bands and the short ends of the neckband. Sew 1 edge of the neckband to inside and 1 edge to outside of the neckline. Sew the armhole bands in place in the same manner.

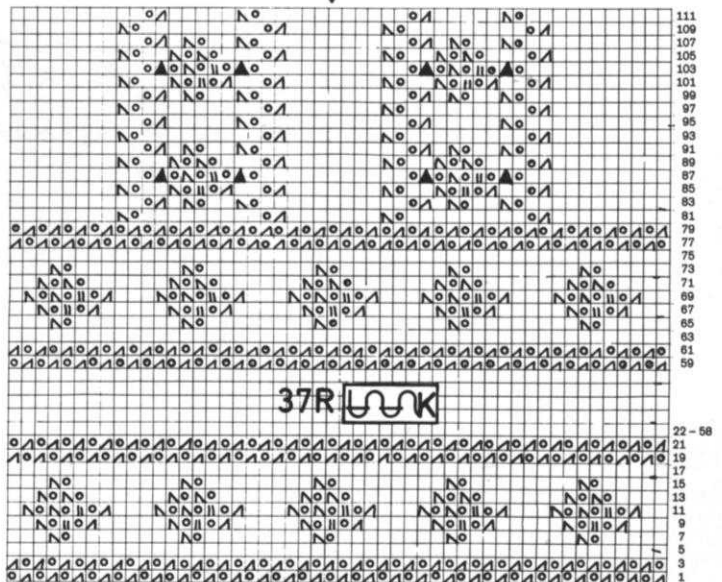

DK 8221

SIZE:	10 (Bust 33"-35")	12/14 (Bust 34"-37")	16/18 (Bust 38"-41")
YARN:	Amore	Crocus Crepe	Allegro
50 gr. BALLS:	24	28	24
	PLUS - 1 SPOOL MONOFIL for all sizes. 12 buttons.		
TENSION:	6 to 8	6 to 8	6 to 8
GAUGE:	2" 16 sts. 22 Rows	15 sts. 21 Rows	14 sts. 20 Rows

The instructions are the same for all sizes. PATTERN: Stockinette Stitch with Norwegian Design on lower edge of Pants and for Sleeves. Follow the Line Drawing or use JAC 40 and Pattern No. 472. Each row in the Norwegian Design is counted as one row but several movements of the Cam Box are needed to complete one row. DECREASES: Hang the 4th st. onto the 3rd needle and move the sts. inward to fill empty needle. INCREASES: Move the 3 end sts. 1 needle outward, then place the 4th st. from the row below onto the empty needle.

FINISHING: Block all sections. BLOUSE: Join front and back sections at sides and shoulders. Sew the sleeves together and set in. Work 2 rows single crochet around lower edges of sleeves, gathering in to measure 8". Work a 3rd row of 3 single crochet and 1 picot (to make Picot, ch 3, slip st. into 3rd ch). Crochet around neck edge and front edges in the same manner, making 12 buttonholes on the right front when working the 2nd row. Sew on buttons. PANTS: Join inner leg seams, then join sections at center back and center front. Turn under 3/4" at waistline and hem to inside, then run elastic through casing. Work 1 row single crochet around lower edge of pants.

continued on page 18

Work the second pants section with reverse shaping, casting on from RIGHT to LEFT. Cam Box will be on the LEFT side at Row 0.

ON OPPOSITE SIDE of CAM BOX, put 45 needles into holding position after Row 408; 8 needles after Rows 410, 412, 414, 416, 418, 420. After Row 422, bring all the needles back into working position and knit to Row 454. Bind off the remaining 115 sts.

Decrease 2 sts. for DART after Rows in (). ON CAM BOX SIDE, decrease 1 st. after Row 336 (336), 342, (346), 348, 354, (356), 360, 366, (366), 372, (376), 378, 384, (386), 390, 396, (396), 402, (406). Knit to Row 408 then work Short Rows.

ON CAM BOX SIDE, bind off 6 sts. after Row 308; 3 sts. after Row 309; 3 sts. after Row 310; 2 sts. after Row 311; 3 sts. after Row 312; 2 sts. after Row 313; 3 sts. after Row 314; 1 st. after Row 315; 2 sts. after Row 316; 1 st. after Row 317; 2 sts. after Row 318; 1 st. after Row 319; 2 sts. after Row 320; 1 st. after Rows 321, 322, 324, 326, 328, 330. Knit to Row 336.

ON EACH SIDE, increase 1 st. after Rows 242, 248, 254, 260, 266, 272, 278, 284, 290, 296, 302. (180 sts.) Knit even to Row 308.

ON OPPOSITE SIDE of CAM BOX, increase 1 st. after Rows in (). ON CAM BOX SIDE increase 1 st. after Rows 212 (212), 218, 224, (224), 230, 236 (236).

ON EACH SIDE, decrease 1 st. after Rows 96, 108, 120, 132, 142, 152, 162, 172. (151 sts.) Knit even to Row 212.

Cast on 193 sts. Knit in Pattern to Row 88; change to stockinette stitch, knit 1 Row then remove the sts. onto contrast waste yarn. Hang the sts. back onto the machine decreasing 26 sts. evenly across (double up the 9th, then every 6th st.). (167 sts.) Continue in stockinette stitch. Knit even to Row 96.

ON CAM BOX SIDE, bind off 3 sts. after Rows 182, 183, 184, 185, 186, 187; 2 sts. after Rows 188, 189, 190, 191, 192, 193, 194, 195; 1 st. after Rows 196, 197, 198, 199, 200, 201, 202, 203, 204, 205, 206, 207, 208, 209, 210, 211, 212, 213, 214, 215, 216, 217, 218, 219, 220, 221, 222, 223, 224, 225, 226, 227; 2 sts. after Rows 228, 229, 230, 231, 232, 233; 3 sts. after Rows 234, 235, 236, 237. After Row 238 bind off the remaining 13 sts.

Rows 162 to 183: Knit even.

Cast on 151 sts. Work even in Pattern to Row 160, change to stockinette stitch, knit 1 row, knit several rows using contrast waste yarn and remove the work from the machine by running the Cam Box across without yarn. Hang the sts. back onto the machine decreasing 48 sts. evenly across (double up the 5th, then every 3rd st.). (103 sts.) Continue in stockinette stitch.

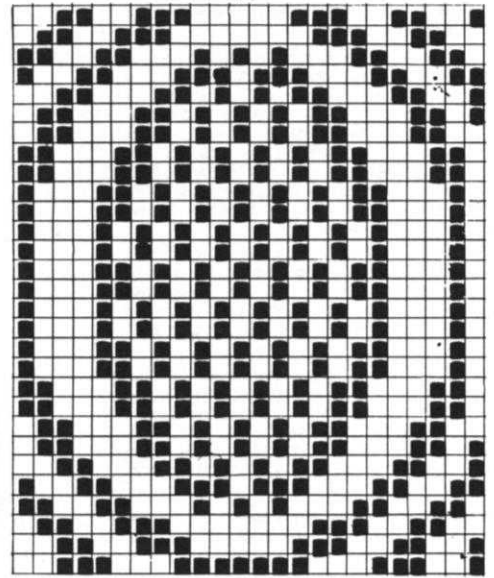

□ = Yarn ■ = Monofil

Work the second front section with reverse shapings, casting on from Right to Left. Cam Box will be on the left side at Row 0.

Continue to decrease 1 st. at front edge after Rows in () and ON CAM BOX SIDE, bind off 4 sts. after Rows 304, 306 (EVEN ROWS = SHOULDER SHAPING); (307); 5 sts. after Rows 308, 310, 312, (313); 5 sts. after Rows 314, 316, 318.

Continue to decrease 1 st. on front edge after Rows 241, 245, 249, 253, 257, 261, 265, 269, 273, 277, 283, 289, 295, 301.

Decrease 1 st. on front edge after Rows in () and ON CAM BOX SIDE, bind off 3 sts. after Rows 226, 228 (EVEN ROWS = ARMHOLE SHAPING); (229); 2 sts. after Rows 230, 232, (233); 1 st. after Rows 234, 236, (237), 238.

ON CAM BOX SIDE, decrease 1 st. after Rows 217, 221, 225.

ON OPPOSITE SIDE of CAM BOX, put into holding position 7 needles after Rows 197, 199, 201, 203, 205. After Row 207, bring all the needles back into working position. ON CAM BOX SIDE, increase 1 st. after Rows 208, 216.

ON CAM BOX SIDE, increase 1 st. after Rows 134, 140, 146, 152, 158, 164, 170, 178, 186, 194. Knit even to Row 197, then work Short Rows.

ON CAM BOX SIDE, decrease 1 st. after Rows 38, 44, 50, 56, 62, 68, 74, 80, 86, 92, 96, 100, 104, 108, 112, 116. (61 sts.) Knit even to Row 134.

Cast on 77 sts. Knit even to Row 38.

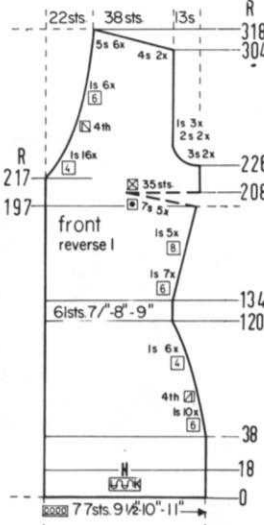
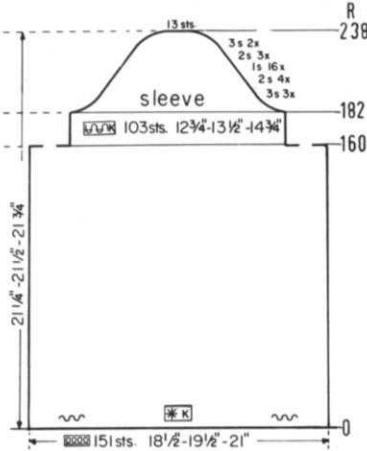
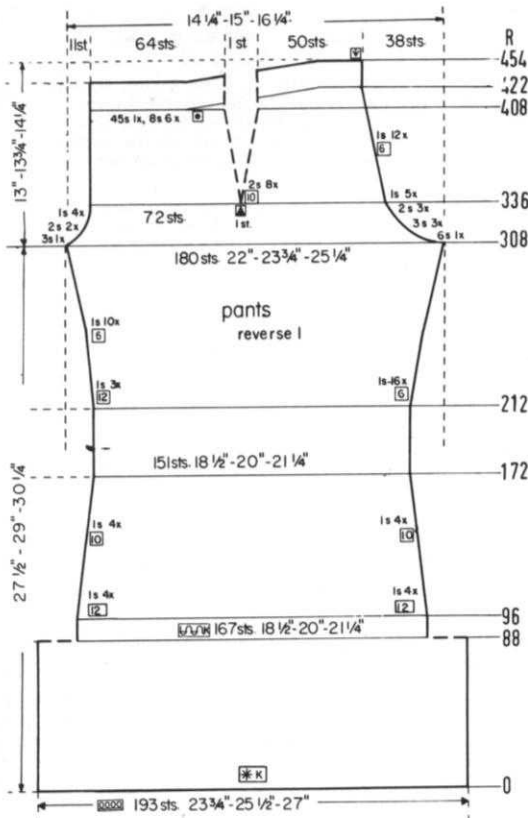

DK8223

SIZE:	8 (Bust 31"-32")	12 (Bust 33"-34")	14 (Bust 35"-36")
YARN:	Beatrice Silver	Beatrice Silver	Beatrice Silver
50 gr. BALLS:	15	16	18
TENSION:	4 to 6	5 to 7	6 to 8
GAUGE:	2" 17 sts. 23 rows	16 sts. 22 rows	15 sts. 21 rows

The instructions are the same for all sizes. PATTERN: Stockinette Stitch. DECREASES: Hang the 4th st. onto the 2nd st., then move the end sts. inward to fill the empty needle. INCREASES: Move the 2 end sts. 1 needle outward, then place the 3rd st. from the row below onto the empty needle. The Bodice section is knitted on to the Skirt section.

FINISHING: Block the sections. Join front and back section at sides and shoulders. Work 1 row of single crochet and 1 row of back-ward single crochet around the neckline edge and armhole edges. Turn under hem allowance and sew in place.

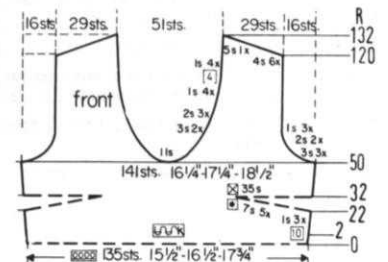

Bring the Cam Box to the left side, turn the Row Counter back to 294 and complete the left half. Follow the instructions from.*

*ON CAM BOX SIDE, bind off 4 sts. after Row 294 (EVEN ROWS = SHOULDER SHAPING); 3 sts. after Row 295 (ODD ROWS = NECK SHAPING); 4 sts. after Row 296; 3 sts. after Row 297; 5 sts. after Row 298; 3 sts. after Row 299; 5 sts. after Row 300; 2 sts. after Row 301; 5 sts. after Row 302; 2 sts. after Row 303; 5 sts. after Row 304; 2 sts. after Row 305; 5 sts. after Rows 306, 308.

ON CAM BOX SIDE, bind off 3 sts. after Rows 216, 217, 218, 219; 2 sts. after Rows 220, 221, 222, 223; 1 st. after Rows 224, 225, 226, 227, 228, 229; then knit even to Row 294, bind off the center 15 sts., put all the needles on the left side into holding position and complete the right half first.

ON EACH SIDE, increase 1 st. after Rows 134, 140, 146, 152, 158, 164, 170, 178, 186, 194, 202, 210 (147 sts.). Knit even to Row 216.

ON EACH SIDE, decrease 1 st. after Rows 38, 44, 50, 56, 62, 68, 74, 80, 86, 92, 96, 100, 104, 108, 112, 116, then knit to Row 134.

Cast on 155 sts. Knit even to Row 58.

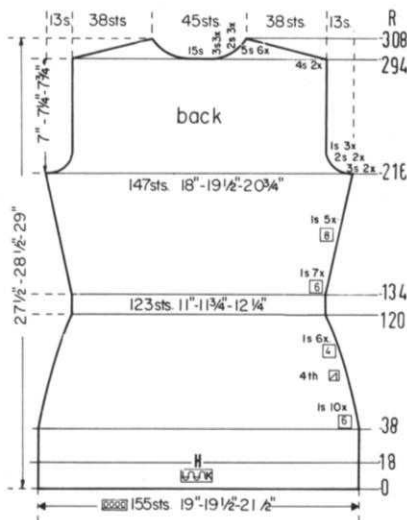

Move the Cam Box to the left side, turn the Row Counter back to 50 and complete the left half. Follow the instructions from*.

*ON CAM BOX SIDE, bind off 3 sts. after Row 50 (EVEN ROWS = ARM-HOLE SHAPING), 51 (ODD ROWS = NECK SHAPING), 52, 53, 54; 2 sts. after Rows 55, 56, 57, 58, 59; 1 st. after Rows 60, 61, 62, 63, 64, 65, 67, 69, 73, 77, 81, then knit to Row 120. For SHOULDER bind off 4 sts. after Rows 120, 122, 124, 126, 128, 130; 5 sts. after Row 132.

ON EACH SIDE, increase 1 st. after Rows 2, 12, 22, but do not knit after the last increase. Work Short Rows for the Bust Darts. ON OPPOSITE SIDE of CAM BOX put into holding position 7 needles after Rows 22, 23, 24, 25, 26, 27, 28, 29, 30, 31. ON OPPOSITE SIDE of CAM BOX bring all needles back into working position after Rows 32, 33, then knit to Row 50, bind off the center 11 sts., put the needles on the left side into holding position and complete the right half first.

Prepare the 3 sections of the skirt front and hang onto the machine as you did the back section. You are then ready to knit the Bodice Front. (135 sts.)

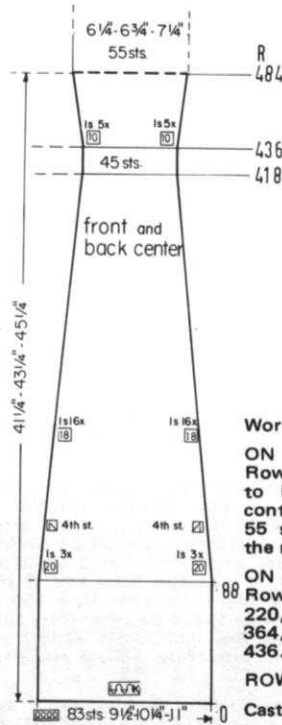

Work the center back section the same.

ON EACH SIDE, increase 1 st. after Rows 436, 446, 456, 466, 476, then knit to Row 484. Knit several rows with contrast waste yarn over the remaining 55 sts., then remove the knitting from the machine.

ON EACH SIDE, decrease 1 st. after Rows 88, 108, 128, 148, 166, 184, 202, 220, 238, 256, 274, 292, 310, 328, 346, 364, 382, 400, 418, then knit to Row 436.

ROWS 0 to 88: Knit even.

Cast on 83 sts. and work stockinette st.

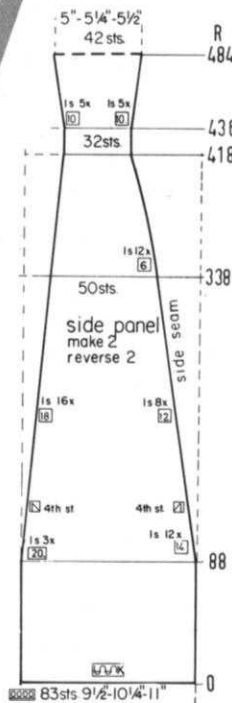
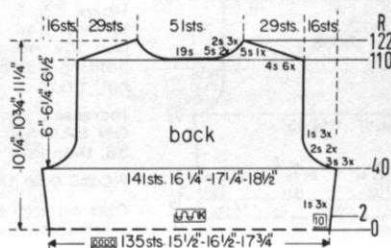

Work 1 more section the same and 2 sections with reverse shapings.

ON EACH SIDE, increase 1 st. after Rows 436, 446, 456, 466, 476, then knit to Row 484. Knit several rows with contrast waste yarn, then remove the knitting from the machine.

ON OPPOSITE SIDE of CAM BOX (this side matches the center panel) decrease 1 st. after Rows in (). ON CAM BOX SIDE (this side is the side seam) decrease 1 st. after Rows 88, (88), 102, (108), 116, (128), 130, 144, (148), 158, (166), 172, (184), 186, 200, (202), 214, (220), 228, (238), 242, 256, (256), 268, (274), 280, 292, (292), 304, (310), 316, 328, (328), 340, (346), 352, 358, 364, (364), 370, 376, 382, (382), 388, 394, 400, (400), 406, 412, 418, (418), then knit to Row 436.

ROWS 0 to 88: Knit even.

Cast on 83 sts. and work stockinette st.

Move the Cam Box to the left side, turn the Row Counter back to 110 and complete the left half. Follow the instructions from*.

*ON CAM BOX SIDE, bind off 4 sts. after Row 110 (EVEN ROWS = SHOULDER SHAPING); 5 sts. after Row 111 (ODD ROWS = NECK SHAPING); 4 sts. after Row 112; 5 sts. after Row 113; 4 sts. after Row 114; 2 sts. after Row 115; 4 sts. after Row 116; 2 sts. after Row 117; 4 sts. after Row 118; 2 sts. after Row 119; 4 sts. after Row 120; 5 sts. after Row 122.

ON CAM BOX SIDE, bind off 3 sts. after Rows 40, 41, 42, 43, 44, 45; 2 sts. after Rows 46, 47, 48, 49; 1 st. after Rows 50, 51, 52, 53, 54, 55, then knit to Row 110, bind off the center 19 sts., put the needles on the left side into holding position and complete the right half first.

ON EACH SIDE, increase 1 st. after Rows 2, 12, 22, then knit to Row 40.

Weave the 3 back sections of the skirt together, 1 st. in from each edge. (1 Center Panel, 1 Right and 1 Left Side Panel). Now hang the open garment sts. back onto the machine. (135 needles). Remove the contrast waste yarn and turn the Row Counter to 0. You are ready to work the Bodice Back.

DK 8222

SIZE:	Small	Medium	Large
YARN:	Melodie	Melodie	Melodie
50 gr. BALLS:	19	20	22
TENSION:	5 to 7	7 to 9	8 to 10
GAUGE:	2" 16 sts. 22 rows	15 sts. 20 rows	14 sts. 19 rows

The instructions are the same for all sizes. PATTERN: Stockinette Stitch. DECREASES: Hang the 4th st. onto the 3rd st., then move the end sts. inward to fill the empty needles.

FINISHING: Block the sections. Weave the back sections together, 1 st. in from each edge. Close the darts. Join back and front sections at sides and shoulders. Turn under 12 sts. on the front edges and hem in place. Sew 1 edge of the neckband to inside and 1 edge to outside of the neckline. Work 1 row of single crochet around the lower edge. To work the fringe, see the Practical Hint in the News Letter.



DK 8208

SIZE:	10 (Bust 32"-33")	12 (Bust 33"-34")	14 (Bust 36"-37")
YARN:			
Main:	Subita Crepe 2 x 3	Beatrice Crepe	Crocus Crepe
Contrast:	Monofil	Monofil	Monofil
50 gr. BALLS:			
Main:	16	19	30
Monofil:	1 spool	1 spool	1 spool
TENSION:	4 to 6	5 to 7	6 to 8
GAUGE:	2" Stk: 18 sts. 24 rows Pattern: 15 sts. 19 rows	17 sts. 23 rows 13 sts. 18 rows	16 sts. 23 rows 13 sts. 18 rows

The instructions are the same for all sizes. PATTERN: Bodice and Sleeves: Stockinette Stitch using the main yarn. Skirt and Scarf: Norwegian Design Method, using the Main Yarn and a filament yarn. (See the News Letter for a description of the filament yarn). Follow the Line Drawing for the Design, or use JAC 40 and Pattern No. 478. In the instructions each row in the Norwegian Design is counted as 1 row, but several movements of the Cam Box are needed to complete 1 row. Make the shapings on the Bodice and Sleeves full-fashion, on the Skirt on the outer edges. Begin the increases for the waist darts by moving the sts. apart as marked in the Diagram. The following increases for the darts lie directly above. Knit the Scarf — for all sizes — with the tension given for Size 10.

FINISHING: Block all sections. Join the skirt sections, leaving about 4" open on the left side. Join the front and back sections of the bodice, leaving about 3" open on the left side. Turn under 8 sts. on the front edges and hem in place. Sew 1 edge of the neckband to inside and 1 edge to outside of the neckline. Gather the lower edge of the upper sleeve sections to the width of the upper edge of the lower sleeve sections, then sew the 2 sections together. Gather the upper edge of the sleeves. Sew the sleeves together and set in. Gather the upper edge of the skirt, then join the skirt to the bodice. Turn under a small amount around the side opening, hem in place and sew in a zipper. Knit a cord for the buttonholes. With the main yarn and tension 1, knit the cord over 2 needles. Knit 190 rows (the empty rows do count). (See the Practical Knitting Hints Book, Page 58). Sew the cord to the right front edge, forming buttonhole loops. (See picture.) Line the skirt section of the dress with taffeta and hem. SCARF: Cut bias strips using the lining material, then bind all scarf edges using tiny sts.

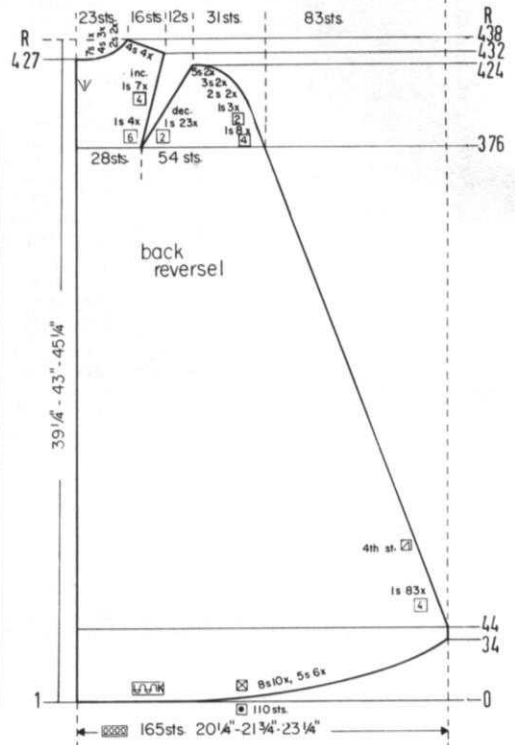

Work the second front section with reverse shapings, casting on from right to left. (Cam Box will be on the LEFT side at Row 0).

ON CAM BOX SIDE, bind off 17 sts. after Row 135; 3 sts. after Rows 137, 139; 2 sts. after Rows 141, 143; 1 st. after Rows 145, 147, 149, 151, 153. For SHOULDER bind off 4 sts. after Rows 154, 156, 158, 160; 5 sts. after Rows 162, 164, 166, 168.

ON CAM BOX SIDE, bind off 3 sts. after Rows 72, 74, 76; 2 sts. after Rows 78, 80; 1 st. after Rows 82, 84, 86, then knit to Row 135.

Increase 2 sts. for the DART and 1 st. ON CAM BOX SIDE after Rows 14, 22, 30, 38, then knit to Row 41 and work Short Rows for the DART. ON OPPOSITE SIDE OF CAM BOX put into holding position 7 needles after Rows 41, 43, 45, 47, 49. After Row 51 bring all needles back into working position, then knit to Row 72.

ROWS 0 to 14: Knit even.

Cast on 72 sts. with the main yarn and work stockinette st.

Move the Cam Box to the left side, turn the Row Counter back to 144 and complete the left half. Follow the instructions from*.

*ON CAM BOX SIDE, bind off 4 sts. after Row 144 (EVEN ROWS = SHOULDER SHAPING); 3 sts. after Row 145 (ODD ROWS = NECK SHAPING); 4 sts. after Row 146; 3 sts. after Row 147; 4 sts. after Row 148; 2 sts. after Row 149; 4 sts. after Row 150; 2 sts. after Row 151; 5 sts. after Row 152; 2 sts. after Row 153; 5 sts. after Row 154; 2 sts. after Row 155; 5 sts. after Rows 156, 158.

ON CAM BOX SIDE, bind off 3 sts. after Rows 62, 63, 64, 65, 66, 67; 2 sts. after Rows 68, 69, 70, 71; 1 st. after Rows 72, 73, 74, 75, 76, 77, then knit to Row 144, bind off the center 22 sts., put the needles on the left side into holding position and complete the right half first.

Increase 2 sts. for EACH DART and 1 st. ON EACH SIDE after Rows 14, 22, 30, 38, then knit to Row 62.

ROWS 0 to 14: Knit even.

Cast on 130 sts. with the main yarn and work stockinette st.

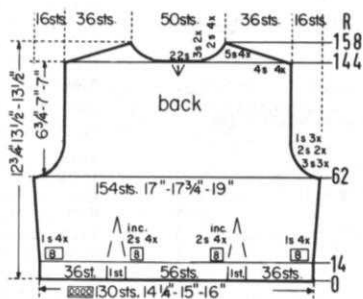
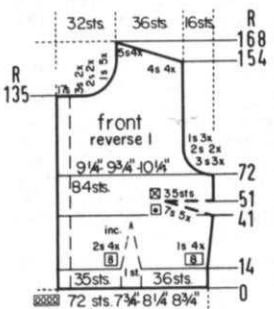
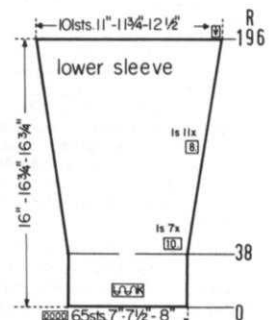
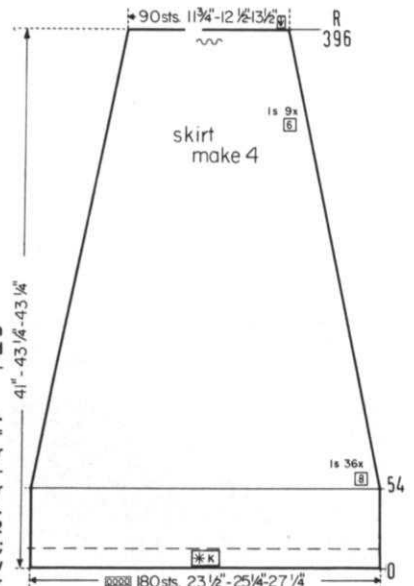

Work the second back section with reverse shapings, casting on from right to left. (Cam Box will be on the left side at Row 0).

ON CAM BOX SIDE, bind off 7 sts. after Row 427 (ODD ROWS = NECK SHAPING), (428), 4 sts. after Rows 429, 431, 432 (EVEN ROWS = SHOULDER SHAPING), 433, 434; 2 sts. after Row 435; 4 sts. after Row 436; 2 sts. after Row 437; 4 sts. after Row 438.

Bring the needles on the left side into working position, turn the Row Counter back to 376. ON CAM BOX SIDE, increase 1 st. after Rows 380, 386, 392, 398, 404, 408, 412, 416, 420, 424, then 1 more time after Row in (). Knit to Row 427.

ON OPPOSITE SIDE of CAM BOX decrease 1 st. after Rows in (). ON CAM BOX SIDE, continue to decrease 1 st. after Rows 376, (378), 380, (380), (382), 384, (384), (386), 388, (388), (390), 392, (392), (394), 396, (396), (398), 400, (400), (402), 404, (404), (406), 408, (408), 410, (410), 412, (412). Continue to decrease 1 st. ON OPPOSITE SIDE of CAM BOX after Rows in (). ON CAM BOX SIDE, bind off 2 sts. after Rows 414, (414), 416; (416), 3 sts. after Rows 418, (418), 420; (420), 5 sts. after Rows 422, (422), 424.

ON CAM BOX SIDE, decrease 1 st. after Row 44, then again after every following 4th row 82 times more. The last of these decreases is after Row 372. Knit to Row 376, then put 28 needles on the left side into holding position and complete the right section first. (Reverse the sides for the second section).

Cast on 165 sts., work stockinette st. and Short Rows. ON OPPOSITE SIDE of CAM BOX put into holding position 110 sts. after Row 1. ON OPPOSITE SIDE of CAM BOX bring back into working position 8 needles after Rows 3, 5, 7, 9, 11, 13, 15, 17, 19, 21; 5 needles after Rows 23, 25, 27, 29, 31, 33, then knit to Row 44.

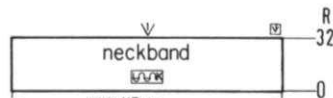

Cast on 115 sts. and work 32 rows stockinette st. then bind off all sts.

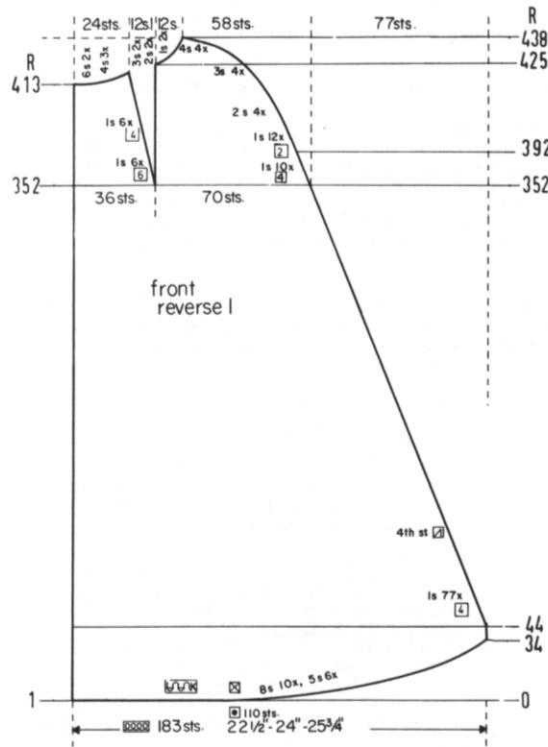

Work the second front section with reverse shapings, casting on from right to left. (Cam Box will be on the LEFT side at Row 0).

ON CAM BOX SIDE, decrease 1 st. after Rows 358, 364, 370, 376, 382, 388, 394, 398, 402, 406, 410, then 1 more time after Row in (). ON NECK SIDE, bind off 6 sts. after Rows 413, (414), 415; 4 sts. after Rows 417, 419, 421.

Bring the 36 needles on the left side into working position, turn the Row Counter back to 352 and complete the left section. (Reverse the sides for the second section).

Continue to decrease 1 st. ON CAM BOX SIDE after Rows 352, 356, 360, 364, 368, 372, 376, 380, 384, 388, 392, 394, 396, 398, 400, 402, 404, 406, 408, 410, 412, 414. Now bind off 2 sts. after Rows 416, 418, 420, 422; 3 sts. after Row 424, 425 (ODD ROWS = NECK SHAPING); 426, 427, 428; 2 sts. after Row 429; 3 sts. after Row 430; 2 sts. after Row 431; 4 sts. after Row 432; 1 st. after Row 433; 4 sts. after Row 434; 1 st. after Row 435; 4 sts. after Rows 436, 438.

ON CAM BOX SIDE, decrease 1 st. after Row 44, then again after every following 4th row 76 times more. The last of these decreases is after Row 348. Knit to Row 352, then put 36 needles on the left side into holding position and complete the right section first. (Reverse the sides for the second section).

Cast on 183 sts., work stockinette st. and Short Rows. ON OPPOSITE SIDE of CAM BOX put into holding position 110 needles after Row 1. ON OPPOSITE SIDE of CAM BOX bring back into working position 8 needles after Rows 3, 5, 7, 9, 11, 13, 15, 17, 19, 21; 5 needles after Rows 23, 25, 27, 29, 31, 33, then knit to Row 44.

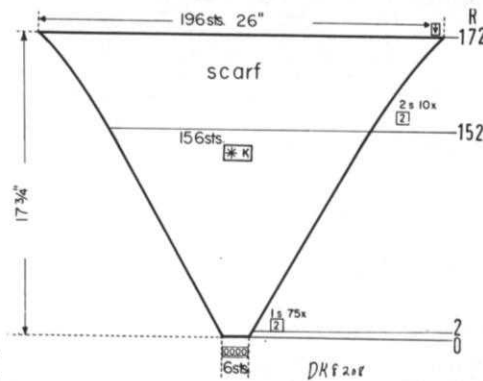

Cast on 2 sts. on CAM BOX SIDE after Rows 152, 153, 154, 155, 156, 157, 158, 159, 160, 161, 162, 163, 164, 165, 166, 167, 168, 169, 170, 171. After Row 172 bind off all sts.

Increase 1 st. ON EACH SIDE, after Row 2, then again after every following 2 rows 74 times more. This will be completed after Row 150, then knit to Row 152.

Cast on 6 sts. and work the Norwegian Design.

Work 3 more sections the same.

ON EACH SIDE, decrease 1 st. after Rows 54, 62, 70, 78, 86, 94, 102, 110, 118, 126, 134, 142, 150, 158, 166, 174, 182, 190, 198, 206, 214, 222, 230, 238, 246, 254, 262, 270, 278, 286, 294, 302, 310, 318, 326, 334, 342, 348, 354, 360, 366, 372, 378, 384, 390, then knit to Row 396 and bind off the remaining 90 sts.

ROWS 0 to 54: Knit even.

Cast on 180 sts. with the main yarn and work the Norwegian Design.

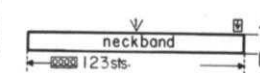

Cast on 123 sts. with the main yarn and work 14 rows stockinette st., then bind off all sts.

ON CAM BOX SIDE, bind off 5 sts. after Row 58, 59, 60, 61; 3 sts. after Row 62, 63, 64, 65, 66, 67; 2 sts. after Rows 68, 69, 70, 71. ON EACH SIDE, hang the 1st st. onto the 2nd st. after Rows 72, 74, 76, 78, 80, 82, 84, 86, 88, 90, 92, 94, 96, 98, 100, 102. ON CAM BOX SIDE, bind off 2 sts. after Rows 104, 105, 106, 107, 108, 109; 3 sts. after Rows 110, 111, 112, 113, 114, 115; 5 sts. after Rows 116, 117, 118, 119; 37 sts. after Row 120.

Cast on 165 sts. with the main yarn, work stockinette st. and Short Rows. ON OPPOSITE SIDE of CAM BOX put into holding position 64 needles after Rows 0, 1. ON OPPOSITE SIDE of CAM BOX bring back into working position 4 needles after Rows 2, 3, 4, 5, 6, 7, 8, 9, 10, 11, 12, 13, 14, 15, 16, 17; 5 needles after Rows 18, 19, 20, 21, 22, 23, 24, 25; 12 needles after Rows 26, 27, then knit to Row 58.

ON EACH SIDE, increase 1 st. after Rows 38, 48, 58, 68, 78, 88, 98, 108, 116, 124, 132, 140, 148, 156, 164, 172, 180, 188, then knit to Row 196 and bind off all 101 sts.

ROWS 0 to 38: Knit even.

Cast on 65 sts. with the main yarn and work stockinette st.

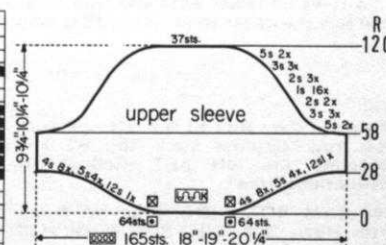
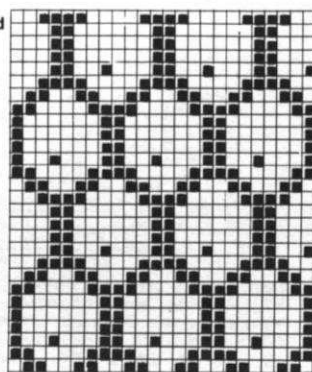

DPS216

SIZE:	12 (Bust 33"-34")	14 (Bust 36"-37")	18 (Bust 39"-40")
YARN:	Beatrice Crepe	Allegro Dralon	Allegro Dralon
50 gr. BALLS:	6 color 1 1 color 2 1 color 3 1 color 4 1 color 5	6 color 1 1 color 2 1 color 3 1 color 4 1 color 5	7 color 1 1 color 2 1 color 3 1 color 4 1 color 5
TENSION:	5 to 7	6 to 8	7 to 9
GAUGE:	2" 16 sts. 22 rows	15 sts. 21 rows	14 sts. 20 rows

The instructions are the same for all sizes. **PATTERN:** Stockinette Stitch and repeated color stripes as marked in the Diagrams. **DECREASES:** Hang the 3rd st. onto the 2nd st., then move the end sts. inward to fill the empty needle. Begin the Sleeve Darts by hanging the sts. together as marked in the Diagram, then move the sts. together to fill the empty needles. The following decreases lie directly above. **INCREASES:** Move the 2 end sts. 1 needle outward, then place the 3rd st. from the row below onto the empty needle. To form the hem, hang the cast-on sts. back onto the machine behind the latches, then knit the following row with 1 or 2 tension settings higher.

FINISHING: Block all sections. Join front and back section at sides and shoulders. Sew the sleeves together and set in. Turn under 24 rows on lower edge of the sleeves and hem in place. Work 1 row of single crochet around the neckline and 1 row of slip-stitch crochet around the opening. Sew in a zipper. Join the belt sections at center back, then sew the long edges together. Insert an elastic band. Close the open ends, then sew a buckle in place.



Move the Cam Box to the left side, turn the Row Counter back to 316 and complete the left half. Follow the instructions from*.

*ROWS 317 to 336: Knit even. For Shoulder bind off 5 sts. after Rows 336, 338, 340, 342, 344, 346, 348.

ON CAM BOX SIDE, bind off 3 sts. after Rows 256, 257, 258, 259, 260, 261; 2 sts. after Rows 262, 263, 264, 265; 1 st. after Rows 266, 267, 268, 269, 270, 271, then knit to Row 280, change to color 2. Work the repeated color stripes as marked in the Diagram. Knit to Row 316, then bind off the center 43 sts., put the needles on the left side into holding position and complete the right half first.

Work the front section the same as the back section to ROW 228, then work Short Rows for the Bust Darts. ON OPPOSITE SIDE of CAM BOX put into holding position 6 needles after Rows 228, 229, 230, 231, 232, 233, 234, 235, 236, 237, 238, 239. ON OPPOSITE SIDE of CAM BOX bring all needles back into working position after Rows 240, 241, then knit to Row 256.

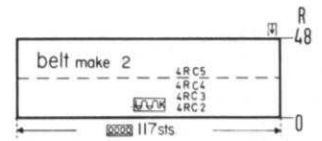

Cast on 117 sts. with color 2, work stockinette st. and the repeated color stripes as marked in the Diagram. After Row 48 bind off all sts. Work the second section the same.

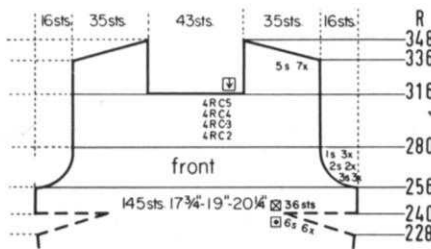
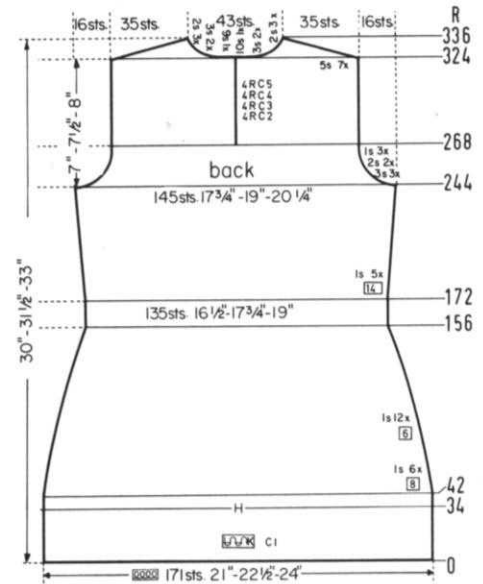

MK5416

SIZE:	8 (Chest 25"-26")	10 (Chest 27"-28")	12 (Chest 29"-30")
YARN:	Subita Crepe 2 x 3	Regia	Regia
50 gr. BALLS:	5 color 1 1 color 2 1 color 3	5 color 1 1 color 2 1 color 3	6 color 1 1 color 2 1 color 3
TENSION:	4 to 6	5 to 7	6 to 8
GAUGE:	2" 17 sts. 24 rows	16 sts. 23 rows	15 sts. 22 rows

The instructions are the same for all sizes. **PATTERN:** Stockinette Stitch. **EDGES and WAIST:** K1, P1, Ribbing with color stripes as marked in the Diagrams. **DECREASES:** Hang the 4th st. onto the 3rd st., then move the end sts. inward to fill the empty needles. Begin the **DARTS** by hanging the sts. together as marked in the Diagram, then move the sts. together to fill the empty needle. The following decreases for the **DARTS** lie directly above. To obtain neat edges on the collar, see Practical Knitting Hint in the News Letter Section. **INCREASES:** Move the 2 end sts. 1 needle outward, then place the 3rd st. from the row below onto the empty needle.

FINISHING: Block all sections. Join front and back section at sides and shoulders. Sew the sleeves together and set in. Turn under 24 rows on lower edge and hem in place. Finish the neckline with matching seam binding, then sew the collar to neckline. (See picture).



Move the Cam Box to the left side, turn the Row Counter back to 282 and complete the left half. Follow the instructions from*.

ON CAM BOX SIDE, bind off 3 sts. after Rows 304, 306, 308; 4 sts. after Rows 310, 312, 314.

*ROWS 282 to 304: Knit even.

Work the front section the same as the back section to ROW 282, then bind off the center 58 sts., put the needles on the left side into holding position and complete the right half first.

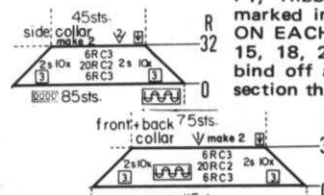
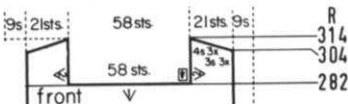

Cast on 115 sts. with color 3, work K1, P1, Ribbing and the color stripes as marked in the Diagram. Decrease 2 sts. ON EACH SIDE after Rows 3, 6, 9, 12, 15, 18, 21, 24, 27, 30. After Row 32 bind off all sts. Work the back collar section the same.

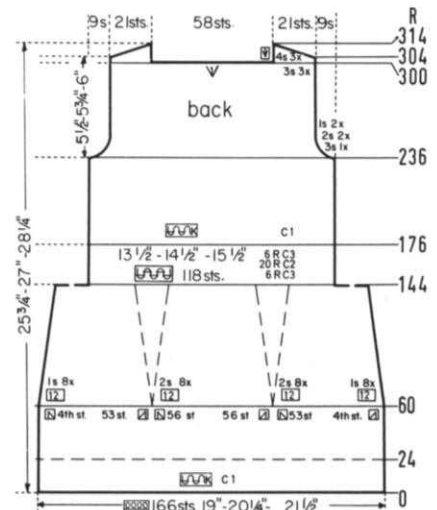

Cast on 85 sts. with color 3, work K1, P1, Ribbing and the color stripes as marked in the Diagram. Decrease 2 sts. ON EACH SIDE after Rows 3, 6, 9, 12, 15, 18, 21, 24, 27, 30. After Row 32 bind off all sts. Work the opposite side section the same.

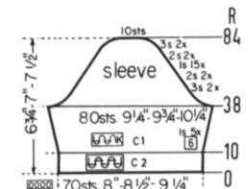

Move the Cam Box to the left side, turn the Row Counter back to 268 and complete the left half. Follow the instructions from *.

ON CAM BOX SIDE, bind off 5 sts. after Row 324 (EVEN ROWS = SHOULDER SHAPING); 10 sts. (9 sts. for the left half) after Row 325 (ODD ROWS = NECK SHAPING); 5 sts. after Row 326; 3 sts. after Row 327; 5 sts. after Row 328; 3 sts. after Row 329; 5 sts. after Row 330; 2 sts. after Row 331; 5 sts. after Row 332; 2 sts. after Row 333; 5 sts. after Row 334; 2 sts. after Row 335; 5 sts. after Row 336.

*Change to color 2, work the color stripes as marked in the Diagram and knit even to Row 324.

ON CAM BOX SIDE, bind off 3 sts. after Rows 244, 245, 246, 247, 248, 249; 2 sts. after Rows 250, 251, 252, 253; 1 st. after Rows 254, 255, 256, 257, 258, 259, then knit to Row 268, put 56 needles on the left side into holding position and complete the right half first.

ON EACH SIDE, increase 1 st. after Rows 172, 186, 200, 214, 228, then knit to Row 244. (For the Front Section knit to Row 228 and make the increases).

ON EACH SIDE, decrease 1 st. after Rows 42, 50, 58, 66, 74, 82, 90, 96, 102, 108, 114, 120, 126, 132, 138, 144, 150, 156, then knit to Row 172.

ROWS 35 to 42: Knit even.

ROWS 0 to 34: Knit even, then form the hem.

Cast on 171 sts. with color 1 and work stockinette st.

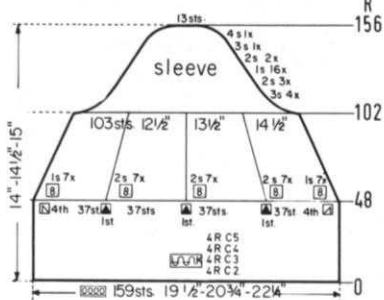

ON CAM BOX SIDE, bind off 3 sts. after Rows 102, 103, 104, 105, 106, 107, 108, 109; 2 sts. after Rows 110, 111, 112, 113, 114, 115. ON EACH SIDE, hang the 1st st. onto the 2nd st. after Rows 116, 118, 120, 122, 124, 126, 128, 130, 132, 134, 136, 138, 140, 142, 144, 146. ON CAM BOX SIDE, bind off 2 sts. after Rows 148, 149, 150, 151; 3 sts. after Rows 152, 153; 4 sts. after Rows 154, 155; 13 sts. after Row 156.

Decrease 2 sts. for EACH DART and 1 st. ON EACH SIDE after Rows 48, 56, 64, 72, 80, 88, 96, then knit to Row 102.

ROWS 0 to 48: Knit even, then continue with color 1.

Cast on 159 sts. with color 2, work stockinette st. and the repeated color stripes as marked in the Diagram.

MK 5432

SIZE:	3 (Chest 21")	4 (Chest 23")	6 (Chest 24"-25")
YARN:	Beatrice Crepe	Beatrice Crepe	Beatrice Crepe
50 gr. BALLS:	3	4	5
TENSION:	5 to 7	6 to 8	7 to 9
GAUGE:	2" 13 sts. 30 rows	12 sts. 29 rows	11 sts. 26 rows

The instructions are the same for all sizes. PATTERN: Holding Position Design according to the Line Drawing, using Wheel No. 3. The purl side is the right side. The omitted needles in the Pattern do count as sts. in the instructions and gauge.

FINISHING: Block the sections lightly. Gather the skirt sections to the width of the lower edge of the bodice sections. Join the bodice sections to the skirt section. Sew front and back sections at sides. Sew 3/4" of each shoulder together. Work 1 row of single crochet around the armhole edges. Gather the sleeve flounce to about 4" to 5", then sew the gathered edges to the upper half of the armholes. (See picture). Work 1 row of single crochet around the neckline and open edges of the shoulders. Work 3 loops and sew 3 buttons on each shoulder.



Move the Cam Box to the left side, turn the Row Counter back to 300 and complete the left half. Follow the instructions from *.

ON CAM BOX SIDE, bind off 3 sts. after Rows 304, 306, 308; 4 sts. after Rows 310, 312, 314.

*ROWS 301 to 304: Knit even.

ON CAM BOX SIDE, bind off 3 sts. after Rows 236, 237; 2 sts. after Rows 238, 239, 240, 241; 1 st. after Rows 242, 243, 244, 245, then knit to Row 300, bind off the center 58 sts., put the needles on the left side into holding position and complete the right half first. (For the Front Section knit to Row 282).

ROWS 177 to 236: Knit even.

ROWS 145 to 176: Knit even, then change to stockinette st. and work with color 1.

Decrease 2 sts. for EACH DART and 1 st. ON EACH SIDE after Rows 60, 72, 84, 96, 108, 120, 132, 144, but do not knit after the last decreases. Transfer every other st. to the ribber, change to color 3, work K1, P1, Ribbing and the color stripes as marked in the Diagram.

ROWS 0 to 60: Knit even.

Cast on 166 sts. with color 1 and work stockinette st.

ON CAM BOX SIDE, bind off 3 sts. after Rows 38, 39, 40, 41; 2 sts. after Rows 42, 43, 44, 45. ON EACH SIDE, hang the 1st st. onto the 2nd st. after Rows 46, 48, 50, 52, 54, 56, 58, 60, 62, 64, 66, 68, 70, 72, 74. ON CAM BOX SIDE, bind off 2 sts. after Rows 76, 77, 78, 79; 3 sts. after Rows 80, 81, 82, 83; 10 sts. after Row 84.

ON EACH SIDE, increase 1 st. after Rows 10, 16, 22, 28, 34, then knit to Row 38.

ROWS 0 to 10: Knit even, then change to stockinette st. and continue with color 1.

Cast on 70 sts. with color 2 and work K1, P1, Ribbing.

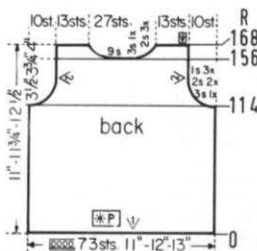

Bring the needles on the left side into working position, knit 1 row in PATTERN to the left side, turn the Row Counter back to 156 and complete the left half. Follow the instructions from *.

*ON CAM BOX SIDE, bind off 3 sts. after Row 157; 2 sts. after Rows 159, 161, 163. After Row 168 bind off the 13 SHOULDER sts.

ON CAM BOX SIDE, bind off 3 sts. after Rows 114, 115; 2 sts. after Rows 116, 117, 118, 119; 1 st. after Rows 120, 121, 122, 123, 124, 125, then knit to Row 156, bind off the center 9 sts., put the needles on the left side into holding position and complete the right half first. (For the Front Section knit to Row 138).

ROWS 0 to 114: Knit even.

Cast on 73 sts. (REMEMBER the empty spaces do count as sts.) and work the Holding Position Design.

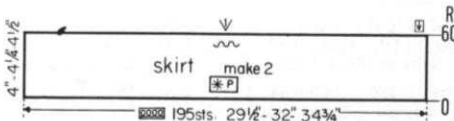

Cast on 195 sts. and work the Holding Position Design. After Row 60 bind off all sts.

Work the second skirt section the same.

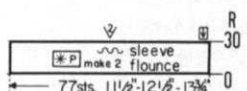

Cast on 77 sts. and work the Holding Position Design. After Row 30 bind off all sts.

Bring the needles on the left side into working position, knit 1 row in PATTERN to the left side, turn the Row Counter back to 138 and complete the left half. Follow the instructions from *.

*ON CAM BOX SIDE, bind off 3 sts. after Row 139; 2 sts. after Rows 141, 143; 1 st. after Rows 145, 147, 149. After Row 168 bind off the 13 SHOULDER sts.

Work the front section the same as the back section to Row 138, then bind off the center 7 sts., put the needles on the left side into holding position and complete the right half first.

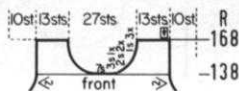

DKS186

SIZE:	8 (Bust 31"-32")	12 (Bust 33"-34")
YARN:	Sport Prima	Sport Prima
50 gr. BALLS:		
JUMPER:	9 color 1 3 color 2 8 color 2	10 color 1 3 color 2 8 color 2
PULLOVER:	small amount of C1	small amount of C1
TENSION:	7 to 9	8 to 10
GAUGE:	2" Stk: 14 sts. 19 rows Pattern: 15 sts. 18 rows	13 sts. 18 rows 14 sts. 17 rows

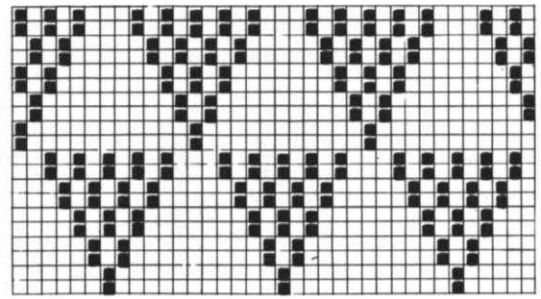

□ Color 1 ■ Color 2

The instructions are the same for both sizes. **PATTERN: PULLOVER:** Stockinette Stitch with a Norwegian Design on the sleeve edges. **JUMPER:** Norwegian Design according to the Line Drawing. In the instructions each row in the Norwegian Design is counted as 1 row, but several movements of the Cam Box are needed to complete 1 row. Make the shapings on the Pullover full-fashion and on the Jumper on the outside edges. To form the hem, hang the cast-on sts. back onto the machine behind the latches.

FINISHING: Block all sections. **PULLOVER:** Join the front and back section at sides and shoulders. Sew the sleeves together and set in. Turn under 12 rows on the sleeve edges and hem in place. Sew 1 edge of the neckband to inside and 1 edge to the outside of the neckline. Work 1 row of slip-stitch crochet around the back opening, then sew in a zipper. **JUMPER:** Join the sections at sides and shoulders. Join the short ends of the armhole bands and the short ends of the neckband. Sew 1 edge of the neckband to inside and 1 edge to outside of the neckline. Sew the armhole bands in place in the same manner. Turn under 2" at lower edge and hem in place.

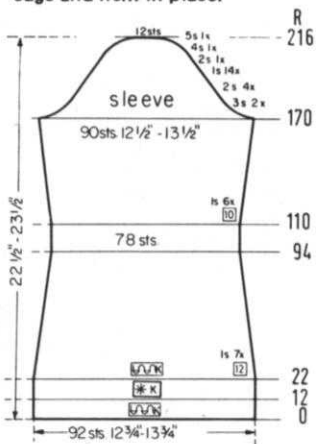

ON CAM BOX SIDE, bind off 3 sts. after Rows 170, 171, 172, 173; 2 sts. after Rows 174, 175, 176, 177, 178, 179, 180, 181. **ON EACH SIDE,** hang the 1st st. onto the 2nd st. after Rows 182, 184, 186, 188, 190, 192, 194, 196, 198, 200, 202, 204, 206, 208. **ON CAM BOX SIDE,** bind off 2 sts. after Rows 210, 211; 4 sts. after Rows 212, 213; 5 sts. after Rows 214, 215; 12 sts. after Row 216.

ON EACH SIDE, increase 1 st. after Rows 110, 120, 130, 140, 150, 160, then knit to Row 170.

ON EACH SIDE, decrease 1 st. after Rows 22, 34, 46, 58, 70, 82, 94, then knit to Row 110.

ROWS 13 to 22: Knit even, then change to color 2 and work stockinette st.

ROWS 0 to 12: Knit even, then begin the Norwegian Design.

Cast on 92 sts. with color 2 and work stockinette st*

Move the Cam Box to the left side, turn the Row Counter back to 210 and complete the left half. Follow the instructions from*.

ON CAM BOX SIDE, bind off 3 sts. after Row 240 (EVEN ROWS = SHOULDER SHAPING); 8 sts. (7 sts. for the left half) after Row 241 (ODD ROWS = NECK SHAPING); 4 sts. after Row 242; 6 sts. after Row 243; 4 sts. after Row 244; 3 sts. after Row 245; 4 sts. after Row 246; 3 sts. after Row 247; 4 sts. after Rows 248, 250, 252. *ROWS 211 to 240: Knit even.

ON CAM BOX SIDE, bind off 3 sts. after Rows 172, 173, 174, 175; 2 sts. after Rows 176, 177, 178, 179; 1 st. after Rows 180, 181, 182, 183, then knit to Row 210, put 46 needles on the left side into holding position and complete the right half first. (For the Front Section knit to Row 210, but do not divide the sts.)

ON EACH SIDE, increase 1 st. after Rows 100, 110, 120, 130, 140, 150, 160, then knit to Row 172.

ON EACH SIDE, decrease 1 st. after Rows 42, 48, 54, 60, 66, 72, 76, 80, 84, then knit to Row 100.

ROWS 21 to 42: Knit even.

ROWS 0 to 20: Knit even, then form the hem.

Cast on 121 sts. with color 2 and work stockinette st.

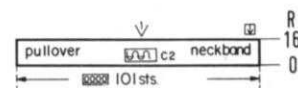
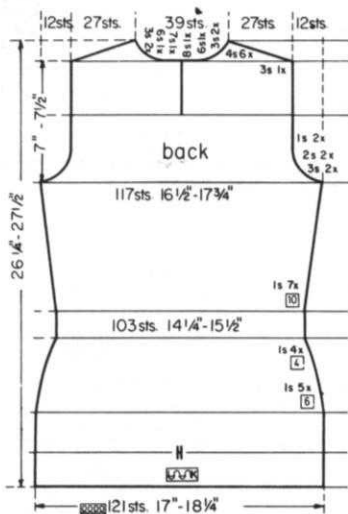

Cast on 101 sts. with color 2 and work 16 rows stockinette st., then bind off all sts.

Move the Cam Box to the left side, turn the Row Counter back to 220 and complete the left half. Follow the instructions from*.

***ON CAM BOX SIDE,** bind off 3 sts. after Rows 221, 223; 2 sts. after Rows 225, 227; 1 st. after Rows 229, 231, 233, 235. For **SHOULDER** bind off 3 sts. after Row 240; 4 sts. after Rows 242, 244, 246, 248, 250, 252.

ROWS 211 to 220: Knit even, then bind off the center 11 sts., put the needles on the left side into holding position and complete the right half first.

Work the front section the same as the back section to ROW 210.

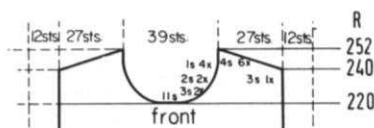

Bring the needles on the left side into working position, knit 1 row in PATTERN to the left side, turn the Row Counter back to 376 and complete the left half. Follow the instructions from*.

*ON NECK SIDE, bind off 5 sts. after Rows 377, 379; 4 sts. after Rows 381, 383. After Row 386 bind off the 15 SHOULDER sts.

ON CAM BOX SIDE, bind off 4 sts. after Rows 310, 311, 312, 313; 2 sts. after Rows 314, 315, 316, 317; 1 st. after Rows 318, 319, 320, 321, 322, 323, 324, 325, 326, 327, 328, 329, 332, 333, 336, 337, 340, 341, then knit to Row 376, bind off the center 23 sts., put the needles on the left side into holding position and complete the right half first. (You may work the opposite shaping at the same time by using separate balls of yarn for each side). For the Front Section knit to ROW 328.

ON EACH SIDE, increase 1 st. after Rows 260, 268, 276, 284, 292, 298, 304, then knit to Row 310.

ON EACH SIDE, decrease 1 st. after Rows 44, 50, 56, 62, 68, 74, 80, 86, 92, 98, 104, 110, 116, 122, 128, 134, 140, 146, 152, 158, 164, 170, 176, 182, 188, 194, 200, 206, 212, 218, 224, 230, but do not knit after the last decreases. Change to color 1 and work the waist-band with stockinette st. as follows:

ROWS 0 to 44: Knit even.

Turn the Row Counter to 0.

ROWS 0-1: Knit with regular tension.

ROWS 2 to 7: Knit with 3 settings lower, then hang the sts. from the first row onto the occupied needles behind the latches.

ROW 8: Knit the sts. together with the regular tension.

ROWS 9 to 22: Knit with 2 settings lower.

ROW 23: Knit with regular tension.

ROWS 24 to 29: Knit with 3 settings lower, then hang the sts. from row 23 onto the occupied needles behind the latches.

ROW 30: Knit the sts. together with the regular tension. Turn the Row Counter to 260. Continue working the Norwegian Design.

Cast on 181 sts. and work the Norwegian Design.

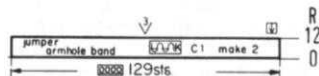

Cast on 129 sts. with color 1 and work 12 rows stockinette st., then bind off all sts.

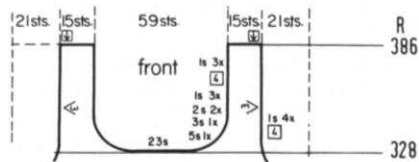

Cast on 173 sts. with color 1 and work 12 rows stockinette st., then bind off all sts.

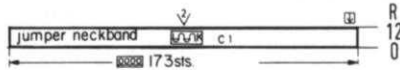

Bring the needles on the left side into working position, knit 1 row in PATTERN to the left side, turn the Row Counter back to 328 and complete the left half. Follow the instructions from*.

*Continue to decrease 1 st. ON ARMHOLE SIDE after Row 328, then again after Rows in (). ON NECK SIDE, bind off 5 sts. after Row 329; 3 sts. after Row 331; (332), 2 sts. after Rows 333, 335; (336), 1 st. after Rows 337, 339, (340), 341, 343, 347, 351, then knit to Row 386 and bind off the 15 SHOULDER sts.

Work the front section the same as the back section to ROW 328, then bind off the center 23 sts., put the needles on the left side into holding position and complete the right half first.

HP3699

SIZE:	36 (Chest 36"-37")	40 (Chest 39"-40")	42 (Chest 42"-43")
YARN:	Sport Prima	Sport Prima	Sport Prima
50 gr. BALLS:	14	15	16
TENSION:	7 to 9	8 to 10	9 to 10
GAUGE:	2" 15 sts. 20 rows	14 sts. 19 rows	13 sts. 18 rows
ALL SIZES:	a 20"-22" Jacket Type Zipper		

The instructions are the same for all sizes. PATTERN: Stockinette Stitch. DECREASES: Hang the 3rd st. onto the 2nd st., then move the end sts. inward to fill the empty needle. INCREASES: Move the 2 end st. 1 needle outward, then place the 3rd st. from the row below onto the empty needle. To form the hem, hang the cast-on sts. back onto the machine behind the latches, then knit the following row with 1 or 2 tension settings higher.

FINISHING: Block all sections. Join back and front sections at sides and shoulders. Sew the sleeves together and set in. Turn under 11 sts. on front edges and hem in place. Sew 1 edge of neckband to inside and 1 edge to outside of the neckline. Turn under 22 rows on the upper edges of the pockets and hem. Sew the open edges together. Sew the pockets in place leaving about 1 1/2" of the hem section free. Turn hem over to right side. (See picture). Sew in the zipper.

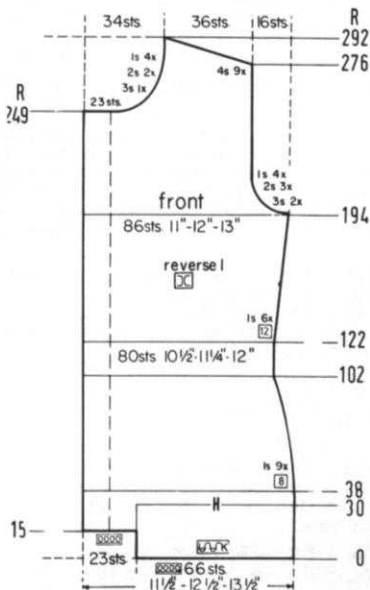

Work the second front section with reverse shapings, casting on from right to left. (Cam Box will be on the LEFT side at Row 0).

ON CAM BOX SIDE, bind off 23 sts. after Row 249; 3 sts. after Row 251; 2 sts. after Rows 253, 255; 1 st. after Rows 257, 259, 261, 263. For SHOULDER bind off 4 sts. after Rows 276, 278, 280, 282, 284, 286, 288, 290, 292.

ON CAM BOX SIDE, bind off 3 sts. after Rows 194, 196; 2 sts. after Rows 198, 200, 202; 1 st. after Rows 204, 206, 208, 210, then knit to Row 249.

ON CAM BOX SIDE, increase 1 st. after Rows 122, 134, 146, 158, 170, 182, then knit to Row 194.

ON CAM BOX SIDE, decrease 1 st. after Rows 38, 46, 54, 62, 70, 78, 86, 94, 102, then knit to Row 122.

ROWS 31 to 38: Knit even.

ROWS 16 to 30: Knit even, then form the hem. (First 66 sts. only).

ROWS 0 to 15: Knit even, then cast on 23 sts. ON CAM BOX SIDE.

Cast on 66 sts. and work stockinette st.

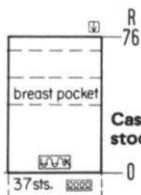

Cast on 37 sts. and work 76 rows stockinette st., then bind off all sts.

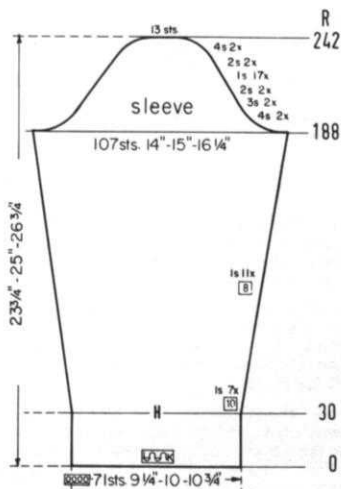

ON CAM BOX SIDE, bind off 4 sts. after Rows 188, 189, 190, 191; 3 sts. after Rows 192, 193, 194, 195; 2 sts. after Rows 196, 197, 198, 199. ON EACH SIDE, hang the 1st st. onto the 2nd st. after Rows 200, 202, 204, 206, 208, 210, 212, 214, 216, 218, 220, 222, 224, 226, 228, 230, 232. ON CAM BOX SIDE, bind off 2 sts. after Rows 234, 235, 236, 237; 4 sts. after Rows 238, 239, 240, 241; 13 sts. after Row 242.

ON EACH SIDE, increase 1 st. after Rows 30, 40, 50, 60, 70, 80, 90, 100, 108, 116, 124, 132, 140, 148, 156, 164, 172, 180, then knit to Row 188.

ROWS 0 to 30: Knit even, then form the hem.

Cast on 71 sts. and work stockinette st.

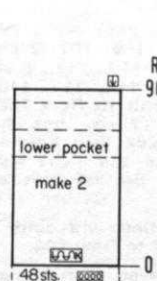

Cast on 48 sts. and work 96 rows stockinette st., then bind off all sts.

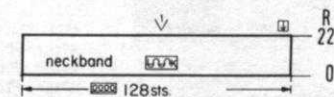

Cast on 128 sts. and work 22 rows stockinette st., then bind off all sts.

Continued on page 26

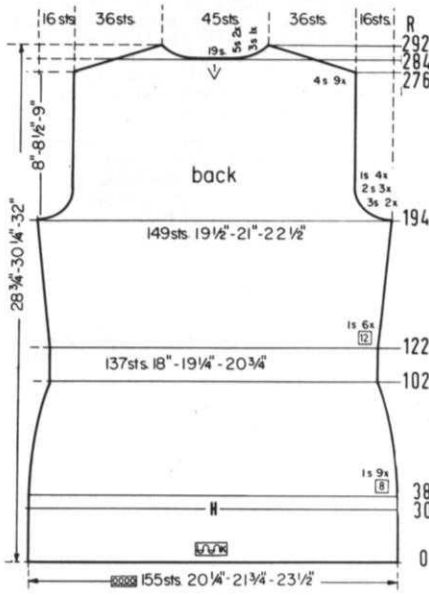

HP 3699

Move the Cam Box to the left side, turn the Row Counter back to 284 and complete the left half. Follow the instructions from*.

*ON CAM BOX SIDE, bind off 4 sts. after Row 284 (EVEN ROWS = SHOULDER SHAPING); 5 sts. after Row 285 (ODD ROWS = NECK SHAPING); 4 sts. after Row 286; 5 sts. after Row 287; 4 sts. after Row 288; 3 sts. after Row 289; 4 sts. after Rows 290, 292.

ON CAM BOX SIDE, bind off 4 sts. after Rows 276, 277, 278, 279, 280, 281, 282, 283, then knit to Row 284, bind off the center 19 sts., put the needles on the left side into holding position and complete the right half first.

ON CAM BOX SIDE, bind off 3 sts. after Rows 194, 195, 196, 197; 2 sts. after Rows 198, 199, 200, 201, 202, 203; 1 st. after Rows 204, 205, 206, 207, 208, 209, 210, 211, then knit to Row 276.

ON EACH SIDE, increase 1 st. after Rows 122, 134, 146, 158, 170, 182, then knit to Row 194.

ON EACH SIDE, decrease 1 st. after Rows 38, 46, 54, 62, 70, 78, 86, 94, 102, then knit to Row 122.

ROWS 31 to 38: Knit even.

ROWS 0 to 30: Knit even, then form the hem.

Cast on 155 sts. and work stockinette st.



KK5-114

SIZE:	2 (Chest 21"-22")	4 (Chest 22"-23")	6 (Chest 24"-25")
YARN:	Amore	Amore	Alanda
50 gr. BALLS:	5 color 1 1 color 2 1 color 3	5 color 1 1 color 2 1 color 3	7 color 1 2 color 2 1 color 3
TENSION:	6 to 8	7 to 9	7 to 9
GAUGE:	2" 16 sts. 25 rows	15 sts. 23 rows	14 sts. 21 rows

The instructions are the same for all sizes. PATTERN: Stockinette Stitch with color stripes as marked in the Diagram. EDGES: K1, P1, Ribbing. DECREASES: Hang the 3rd st. onto the 2nd st., then move the end sts. inward to fill the empty needle. Begin the DART by hanging the sts. together as marked in the Diagram, then hang the sts. together to fill the empty needles. The following decreases, then increases for the Dart lie directly above. INCREASES: Move the 2 end sts. 1 needle outward, then place the 3rd st. from the row below onto the empty needle.

FINISHING: Block all sections. PANTS: Sew the inner leg seams together. Join the sections at center back and center front. Turn under 18 rows on leg edges and 14 rows on upper edges and hem to wrong side. Insert an elastic band into the upper hem. PULLOVER: Join front and back section at sides and shoulders. Join the short ends of the armhole bands and the short ends of the neckband, then sew the bands in place.



Move the Cam Box to the left side, turn the Row Counter back to 156 and complete the left half. Follow the instructions from*.

*ON NECK SIDE, bind off 3 sts. after Rows 157, 159; 2 sts. after Rows 161, 163; 1 st. after Rows 165, 167. After Row 168 bind off the 12 SHOULDER sts.

ON CAM BOX SIDE, bind off 3 sts. after Rows 104, 105, 106, 107; 2 sts. after Rows 108, 109, 110, 111; 1 st. after Rows 112, 113, 114, 115, 116, 117, 118, 119, then knit to Row 156, bind off the center 17 sts., put the needles on the left side into holding position and complete the right half first. (For the Front Section knit to ROW 140).

ROWS 17 to 104: Continue with color 1 after Row 88, then knit to Row 104.

ROWS 0 to 16: Knit even, then change to stockinette st. and work the repeated color stripes as marked in the Diagram.

Cast on 93 sts. with color 2 and work K1, P1, Ribbing.

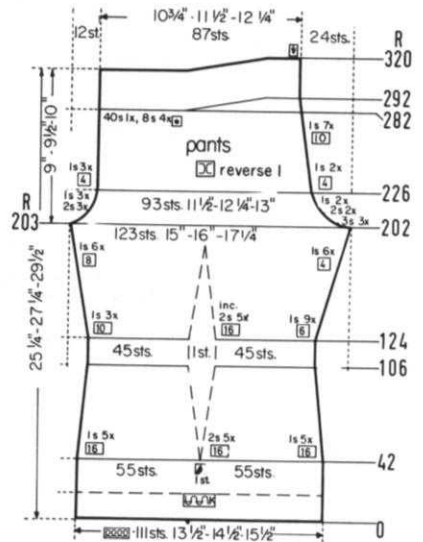
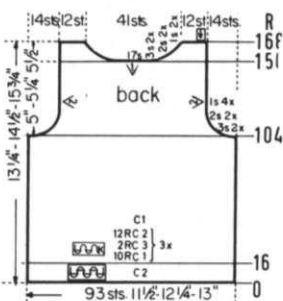

Move the Cam Box to the left side, turn the Row Counter back to 140 and complete the left half. Follow the instructions from*.

*ON CAM BOX SIDE, bind off 3 sts. after Rows 141, 143; 2 sts. after Rows 145, 147; 1 st. after Rows 149, 151, 153. After Row 168 bind off the 12 SHOULDER sts.

Work the front section the same as the back section to ROW 140, then bind off the center 15 sts., put the needles on the left side into holding position and complete the right half first.

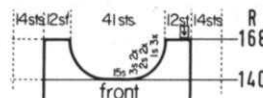

KG 1960 GINGERBREAD TOY PILLOW

MATERIAL: 3 50gr. BALLS Brown KNITKING Flamingo Dralon; 1 50 gr. BALL White Allegro for trim. **TENSION:** 7 to 9. **GAUGE:** 14 sts., 19 Rows = 2"

FINISHING: With WRONG sides together, pin the two sections, then baste close around the edge. Sew on the sewing machine 1/8" from edge, leaving the space between the legs open for stuffing. Stuff lightly, then sew up opening. Pull trim downward so that it forms scallops. Begin with cast on edge of trim and at edge of skirt bottom, pin trim all around edge and sew (by hand) one edge to the right side and one to wrong side of toy Pillow. Pull out the contrast waste yarn and any extra rows if you have any, of the trim, then finish off edge and sew down. Using white felt, cut two 1" circles for eyes; 1/2" circle for nose and a 1/4 moon shape for mouth measuring approximately 3" from one corner or mouth to the other. Cut pupils out of black felt 5/8 in diameter. Sew all face pieces onto pillow as shown in picture, using tiny invisible stitches. Make large pom-pom and sew to top of head. Make 3 medium size pom-poms and sew to front for buttons.

Begin with needle 28 on the left side of machine and cast on 24 sts. from LEFT to RIGHT

*Put 6 needles ON OPPOSITE SIDE of CAM BOX into holding position at Row 0 and after Row 1.

Bring back into working position, 1 needle OPPOSITE CAM BOX before knitting each row till all are in work (Row 14).

Knit even to Row 26*. Break yarn leaving a long end, then put these needles into holding position. Leave 8 empty needles to the right of these needles and cast on 24 sts. to the right. Put Counter at 0 and REPEAT the instructions from * to *.

Cast on the center 8 sts. with strand of hanging yarn, then cast on 7 sts. ON EACH SIDE. (Use separate yarn for left side) 70 sts.

INCREASE 1 st. after Rows 28, 29, 30, 31, 32, 33, 34, 35, 36, 37, 38, 39 (82 sts.).

ON EACH SIDE, DECREASE 1 st. after Rows 44, 48, 52, 56, 60, 64, 68, 72, 76, 80, 84, 88, 90 (56 sts.) (Row 92).

Cast on 4 sts. after Rows 94, 95; 3 sts. after Rows 96, 97; 2 sts. after Rows 98, 99, 100, 101; 1 st. after Rows 102, 103, 104, 105, 106, 107, 108, 109, 110, 111, 112, 113. Knit even to Row 122. (90 sts.).

ON EACH SIDE, DECREASE 1 st. after Rows 122, 124, 126, 128. Bind off 2 sts. after Rows 130, 131, 132, 133; 3 sts. after Rows 138, 139; 6 sts. after Rows 140, 141 (60 sts.).

ON EACH SIDE, INCREASE 1 st. after Rows 142, 145, 148, 151, 154, 157, 160, (70 sts.).

ON EACH SIDE, DECREASE 1 st. after Rows 163, 166, 169, 172, 175 (56 sts.). Knit even to Row 178.

ON EACH SIDE, DECREASE 1 st. after Rows 178, 180, 182, then work short rows.

ON OPPOSITE SIDE OF CAM BOX, put 2 needles into holding position after Rows 184, 185; 3 needles after Rows 186, 187; 4 needles after Rows 188, 189, 190, 191; 5 needles after Rows 192, 193.

ON OPPOSITE SIDE of CAM BOX, bring all the needles back into working position after Rows 194, 195. After Row 196, bind off 54 sts.

MAKE THE SECOND SECTION THE SAME.

TRIM: White Allegro Dralon. Tension 6 or 7.

Cast on 9 sts. Knit 2 rows.

*Put needles 1, 2, 3, 7, 8, 9 into holding position (counting from the right).

Knit 6 rows - do not wrap the yarn. Bring all needles into working position. Knit 6 rows.

REPEAT from * to Row 1512 then remove onto contrast waste yarn.

Work the second pants section with reverse shapings, casting on from right to left. (Cam Box will be on the LEFT side at Row 0).

ON CAM BOX SIDE, bind off 3 sts. after Row 202 (EVEN ROWS = CENTER BACK); 2 sts. after Row 203 (ODD ROWS = CENTER FRONT); 3 sts. after Row 204; 2 sts. after Row 205; 3 sts. after Row 206; 2 sts. after Rows 207, 208; 1 st. after Row 209; 2 sts. after Row 210; 1 st. after Rows 211, 212, 213, 214, 215, 216, 219, 220, 223, 224, 234, 244, 254, 264, 274, then 1 more time after Row in (). Knit to Row 282 and work Short Rows. ON OPPOSITE SIDE OF CAM BOX put into holding position 40 needles after Row 282; 8 needles after Rows 284, (284), 286, 288, 290. After Row 292 bring all needles back into working position, then knit to Row 320 and bind off the remaining 87 sts.

Increase 2 sts. for the DART after (DART). ON OPPOSITE SIDE of CAM BOX increase 1 st. after Rows in (). ON CAM BOX SIDE, increase 1 st. after Rows 124, (124), (DART 124), 130, (134), 136, (DART 140), 142, (144), 148, 154, (154), (DART 156), 160, (162), 166, (170), 172, (DART 172), 178, (178), 182, 186, (186), (DART 188), 190, 194, (194), 198, then knit to Row 202.

Decrease 2 sts. for the DART and 1 st. ON EACH SIDE after Rows 42, 58, 74, 90, 106, then knit to Row 124.

ROWS 0 to 42: Knit even.

Cast on 111 sts. and work stockinette st.

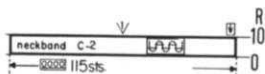

Cast on 115 sts. with color 2 and work 10 rows K1, P1, Ribbing, then bind off all sts.

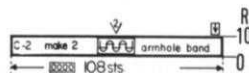

Cast on 108 sts. with color 2 and work 10 rows K1, P1, Ribbing, then bind off all sts.

KG 1961 GOLF CLUB MITTS

MATERIAL: 3 50 gr. balls main Color, a few yards contrast Color KNITKING Sport Prima. **TENSION:** 8 to 10. **GAUGE:** 13 sts., 18 Rows = 2". **PATTERN:** Stockinette stitch with K3, P1, Ribbing.

With Main Color, cast on 47 sts. and work K3, P1, Ribbing. Knit even to Row 42, then transfer the ribber sts. to main machine.

Put Counter at 0 and continue with stockinette stitch.

ROWS 1 to 12: Main Color.
ROWS 13 to 14: Contrast Color.
ROWS 15 to 18: Main Color.
ROWS 19 to 20: Contrast Color.
ROWS 21 to 24: Main Color.
ROWS 25 to 26: Contrast Color.
ROWS 27 to 30: Main Color.
ROWS 31 to 32: Contrast Color.
ROWS 33 to 38: Main Color.

Put 24 needles on the LEFT SIDE into holding position and work short rows.

ROWS 39 to 52: ON OPPOSITE SIDE OF CAM BOX, put 1 needle into holding position after every row until there are 7 needles in holding position on the right side, and 10 sts. in the center.

ROW 53: Leave 7 needles on the right side in holding position, all other needles in work, knit 1 row to the left side.

ROWS 54 to 67: Leave 24 needles on the left in working position, all other needles in holding position and work short rows. The same as you did for the right side.

ROW 68: Leave 7 needles on the left side in holding position, all other needles in work, knit 1 row to the right side.



ROWS 69 to 70: Put all the needles in work and knit 2 rows, ending on the right side. Bind off.

For 3 stripes, omit the first stripe and work the same as for the first Mitt. (Be sure to knit the correct number of rows however - using the main color yarn for the omitted stripes).

For 2 stripes, omit the first stripe and the last stripe.

For 1 stripe, omit the first two stripes and the last stripe.

FINISHING: Weave the side seams together on each mitt and working on the wrong side, single crochet the tops together.

LOOPS on MITTS: Use Tension 4 or 5. Cast on 3 sts. Knit 2 rows. Push the right control button BACK (to make a cord) and knit 28 rows more. Bind off. Make one for each mitt, then sew to top of each.

CORD for Holding all Mitts: Cast on 3 sts., set machine for knitting a cord as you did before and knit 230 rows. Bind off. Pull long cord through loops on top of mitts, then fasten ends together.

KG 1962 HAIRPIN LACE BERET

SIZE: Fits average size head.

MATERIAL: 1 50 gr. ball Color 1, 1 50 gr. ball Color 2, KNITKING Dunja.

TENSION: 6.

PATTERN: NEEDLE SET UP: 1 needle in working position; 5 needles out of work; 3 needles in work; 5 needles out of work; 1 needle in work.

Cast on over the 5 needles in working position.

*Knit 4 rows. Count back 4 rows and pick up the first and third sts. of the 3 center sts., and hang them onto the center needle and put behind the latch. REPEAT from * for PATTERN.

NOTE: BEGIN and END EACH STRIP by knitting only 2 rows (instead of the 4). When each strip is completed, pick up the 3 center cast on sts., hang them onto the center 3 needles and bind off. Drop each end st. from the machine (to be unraveled later).

STRIP 1: With Color 1, knit in Pattern to Row 72.

STRIP 2: With Color 2, knit in Pattern to Row 144.

STRIP 3: With Color 1, knit in Pattern to Row 252.

STRIP 4: With Color 2, knit in Pattern to Row 378.

STRIPS 5 and 6: NEEDLE SET UP: 1 needle in work; 2 needles out of work; 3 needles in work; 2 needles out of work; 1 needle in work. Make STRIP 5 using Color 1 and STRIP 6 using Color 2. Knit both strips in Pattern to Row 256.

BAND: With Color 1, cast on 80 sts. over EVERY OTHER NEEDLE. Knit stockinette stitch to Row 20. Hang hem by picking up each cast on st. and hang onto the machine in FRONT OF THE LATCHES. Machine owners other than KNITKING owners, be sure the original sts. are placed behind the latches before hanging the cast on sts. onto the machine, then pull the cast on sts. through the sts. that are behind the latches. KNITKING machine owners, push the RIGHT Cam Control Button back and knit 2 rows. (release button). Take the sts. off onto contrast waste yarn.

FINISHING: The PURL side is the RIGHT SIDE.

Weave short ends of band together and set aside.

STRIP 1: Thread tapestry needle with yarn, and run the yarn through loops as you unravel 1 st. at a time from 1 side. Pull up tightly and secure (center of hat).

STRIP 2: Working with one side of strip 2 and other side of strip 1, unravel and pull 2 loops from strip 1 through 4 loops from strip 2. Take last group of sts. and anchor to wrong side.

STRIP 3: Put together in the same way, taking 2 loops of strip 2 through 4 loops, then 3 loops alternating from strip 3. End as before, anchoring to the wrong side.

STRIP 4: Take 2 loops from strip 3 through 3 loops from strip 4. Finish as before.

STRIP 5: Take 3 loops from strip 4 through 2 loops from strip 5. Finish as before.

STRIP 6: Take 2 loops from strip 5 through 2 loops from strip 6. Finish as before.

BAND: Slip stitch the open sts. of band to the 6th strip, taking 2 loops, then 1 loop etc. as necessary from strip 6 to fit hat onto the band. Remove waste yarn.

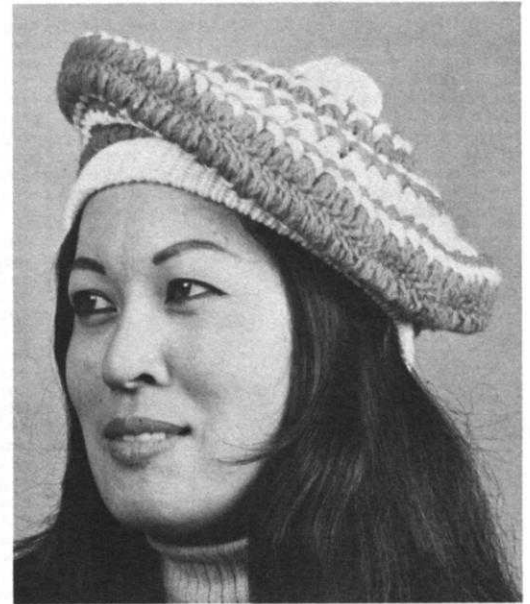

New design winder

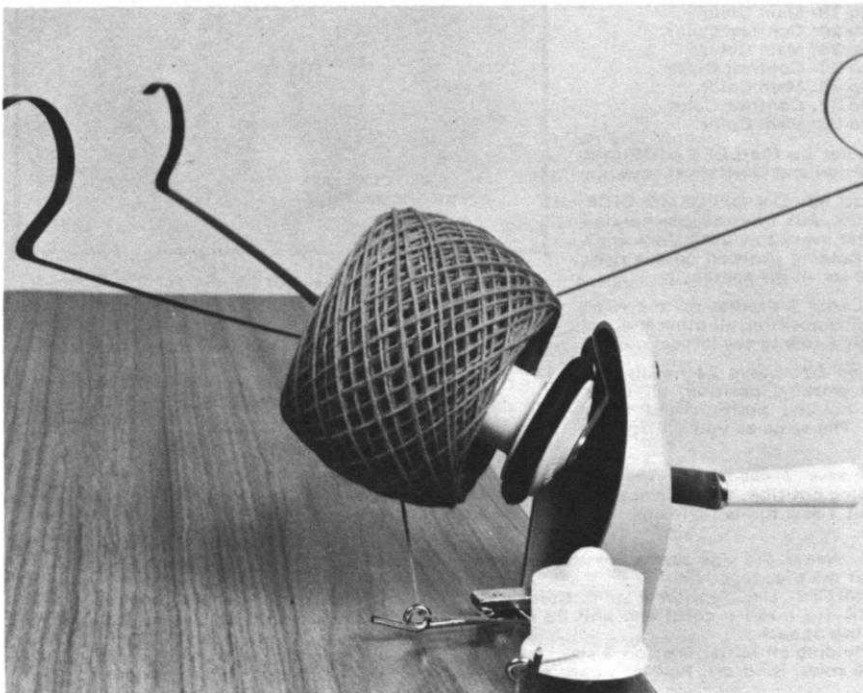

New design Yarn Winder with 'Waxamajig' and Skein Holder. As you can see from the illustration, this clever New Winder with Nylon Helical Gears winds a perfectly symmetrical ball . . . ! If you like to wax yarn (for easier knitting) you use the 'Waxamajig'. If waxing is not necessary, you bypass it . . . The Skein Holder is self adjusting. You will not find a better Hand Winder anywhere.

Complete price: \$23.95
Special Introductory Price: \$19.95
(California residents add 5% Sales Tax)
Shipping charges: \$1.75

Another first from Knitking!!!

THE ~~WHIZ KING~~ PATTERN READER with complete Charting Service

- With **WHIZ KING** you know exactly what to do without reference to written instructions.
- With **WHIZ KING** you no longer have to count rows ... Your Pattern Chart turns automatically as you knit.
- With **WHIZ KING** you can knit even the most intricate patterns easily and speedily.
- With a **WHIZ KING** Pattern Reader, even the complete newcomer to machine knitting can immediately knit garments.
- With **WHIZ KING**, Charts are available from **KNITTING MAGAZINE** Patterns in the size of your choice.

PRICE: 49.50 Complete with instructions, practice Charts and illustrations of 50 complete Patterns for the entire family. (California residents add 5% Sales Tax)
Shipping costs \$2.50.

ORDER DIRECT FROM **KNITTING** 1128 CRENSHAW BLVD. • LOS ANGELES, CALIFORNIA 90019

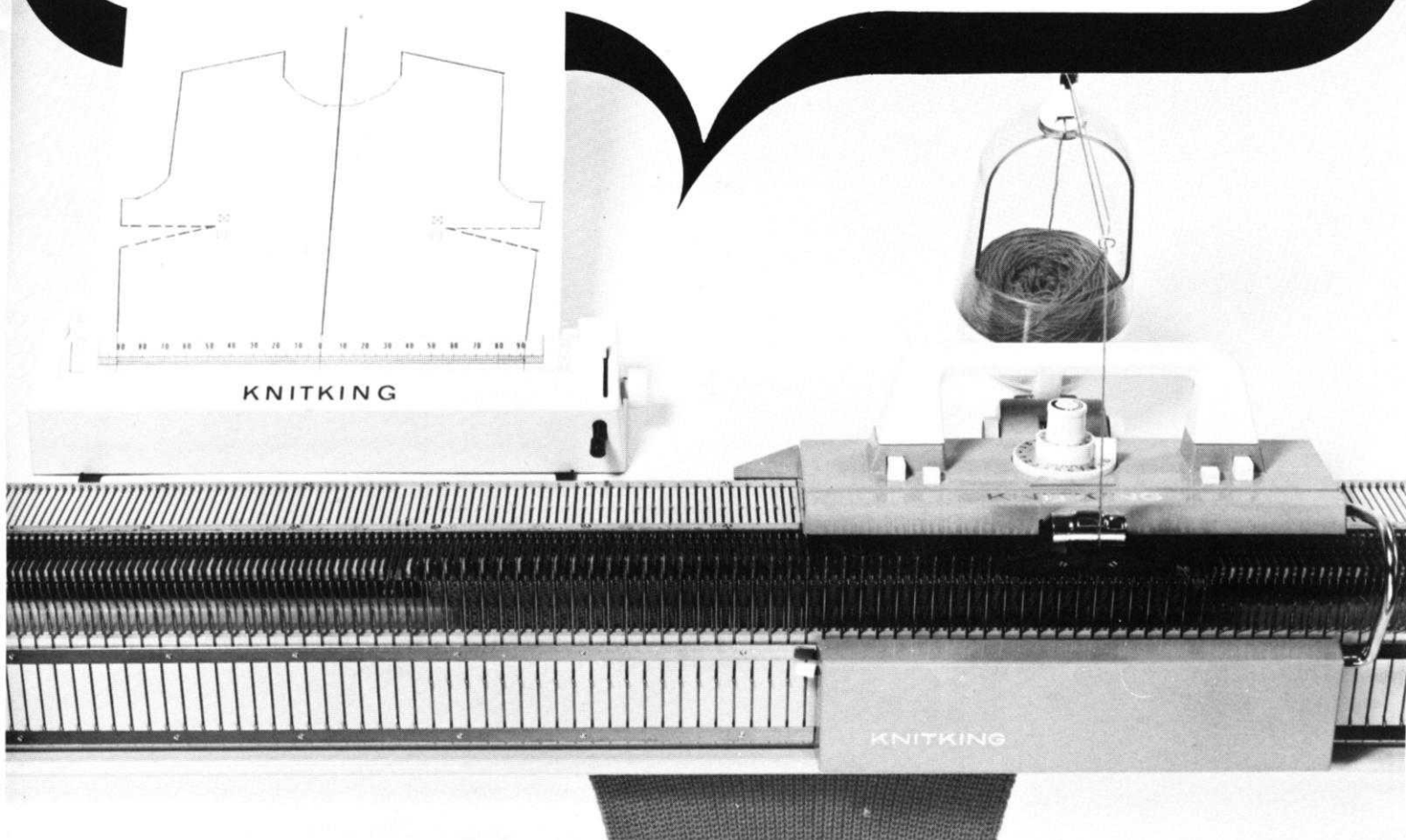



garden party

MK 5432 — We think she's a Doll . . . and any little girl will look like one when wearing this precious Dress with butterfly sleeves and a flounce of a skirt. Use Wheel No. 3 for the Pattern. Sizes 3, 4 and 6 are all made with Beatrice Crepe.

DP 8216 — A beautiful Tunic with Bell Sleeves is knitted in Stockinette stitch using 5 colors for the stripes on the Yoke, sleeve edges and Belt. Knit Size 12 with Beatrice Crepe; Sizes 14 and 18 with Allegro.



MK 5416 – Little girls love to wear knitted dresses and this one is easy to knit in Stockinette stitch. 1 x 1 Ribbing bands the waistline and is used for Collar and Sleeve edges. Size 8, Subita Crepe; Sizes 10 and 12, Regia.



KK 5414 — Perfect Pants and Top for a small boy (can also be made for a girl) are knitted in Stockinette stitch with wide stripes on the top sections. Three colors of Amore for Size 2 and 4; Set 70 Crepe for Size 6.



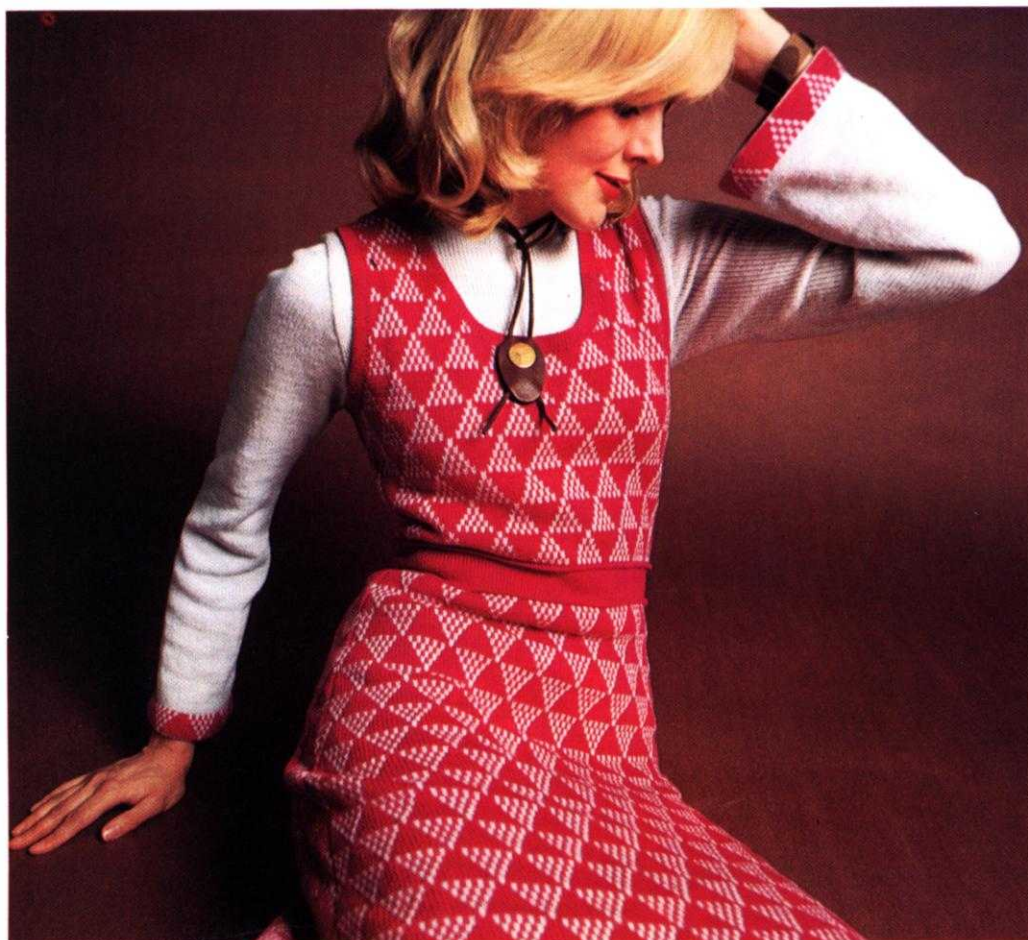

for cool days

DK 8186 — A super Jumper and Pullover ensemble . . . The Jumper is in a Norwegian Design that follows the Line Drawing, the Pullover is knitted in Stockinette stitch with the Norwegian Design for trim on the sleeves. For a change, wear the Jumper without the Pullover or with a blouse.

DK 8194 — We all love to wear a basic Chanel type Suit . . . and this exquisite two piece has the look of Tapestry. Choose a light color for the background, the darker color for weaving. Use your JAC 40 and Pattern No. 466 or follow the Line Drawing. If you do not have a KNITKING Weaver, be sure to order one now. Size 14 and 16, Beatrice Crepe for knitting the Background, Dolly Dralon for the Weaving.

HP 3699 — He'll wear this strictly masculine Jacket for all seasons. It is knitted with KNITKING Sport Prima in Stockinette stitch and has a zipped closure plus pockets for his treasures. Sizes 36, 40 and 42.



NOTES TO KNIT BY . . .

STITCH AND ROW GAUGE

KNIT A SAMPLE SWATCH . . . before you begin to knit any garment . . . for this is the MOST IMPORTANT STEP toward the correct size and the proper fit of any garment you wish to make. You MUST use the SAME YARN for your sample swatch that you will use to knit your garment and your sample swatch must be knitted large enough and using several different tension numbers on your machine. When you have done this, then you can determine the number of stitches and the number of rows in a two-inch measure. KNITTING MAGAZINE PATTERNS give you 3 tensions to try and one of them should give you the correct stitch and row gauge if you are using the yarn we recommend or a similar weight yarn. Here is the way to make your sample swatch.

Cast on over a sufficient number of needles to produce a swatch at least 4 inches wide. (If the pattern calls for 16 stitches to 2", then $16 \times 2 = 32$ stitches to cast on). Now knit 4 inches of rows at the first suggested tension number. (If the pattern calls for 22 rows to 2", $22 \times 2 = 44$ rows to knit). Knit 2 rows using a contrast color, change to the next higher tension and with garment yarn knit another 4", knit 2 rows with contrast color, change to the 3rd higher tension and knit another 4" and then bind off.



Roll the swatch into a cylinder over its length and pull on both ends, unroll it and stretch it diagonally by pulling on the four corners. Allow the swatch to rest and settle (preferably overnight) and then using a stitch gauge or a ruler, count the number of stitches over a 2" width, then the number of rows over a 2" length in EACH of the 3 tensions. Select the tension number that produces the stitches and rows called for in the pattern. If none of them are correct, you are most likely using the wrong weight of yarn.



READING OF CHARTS

You will notice the instructions start at the bottom of the Chart and work UP. Follow the charts exactly as written and providing your sample stitch and row gauge is correct, your garment will come out the right size. Please remember that the section of garment as it is knitted on the machine, faces the same way as the Charts are in this magazine. Where two front pieces are needed, (or any other part of a garment that needs two sections) only one section is normally shown and the second section is usually made with reverse shaping. Set in sleeves are usually identical, but raglan sleeves have to be knitted with reverse shaping for the second sleeve.

READING OF SYMBOLS

To simplify Pattern Knitting, we use Symbols in the Line Drawings and the Chart Diagrams. In the Line Drawings the symbols are shown and are to be read as you look at them while knitting a garment. For instance, if

a Purl stitch faces you, the Purl stitch Symbol  is shown; if a knit stitch faces you (as when using the Ribber) then this Symbol  is shown. The Symbol  at the top of the Line Drawing is the center of the garment section and you use this as a guide for setting up the needles.

The following Symbols    are used for Eyelet Designs in the Line Drawings and also for Full Fashion shaping on the Charts. The Line Drawings have row numbers on the right side. Missing Row numbers are always knitted straight or plain.

In Holding Position Designs  selected needles are pushed into holding position for the stated number of rows. The numbers of rows appear at the right of the Line Drawings; Example: 1-4 means knit Rows 1 to 4; 5 to 7 means knit Rows 5 to 7, etc. This same Symbol is also shown on the Charts and is used for putting needles into holding position for Short Rows. The

Symbol  on the Charts is used to put needles back into working position when knitting Short Rows.

A number in a box stands for the number of rows to be knitted between shapings. Make shaping first, then knit the necessary number of rows. If for instance it reads:

1 st. 8 x



1 st. 10 x



As you will be reading the instructions from the bottom up, here is the way you will follow them: . . . Decrease or increase (depending on the direction of the garment outline) 1 st. at the row where the shaping begins, then knit 8 rows, make the next decrease, then knit 8 rows, until you have decreased (or increased) 1 st. 10 x and you have knitted 8 rows after each decrease (or increase) (1 st. 10 x +8 rows 10 x). Now begin the first decrease (or increase) for the shaping (which has to be made 8 x) in every 6th row. Decrease (or increase) 1 st. first, then knit 6 rows until you have decreased 1 st. 6 x and after each decrease (or increase) have knitted 6 rows (1 st. 8 x + 6 rows 8 x).

Where shapings are given without a boxed number as on most armholes, necklines, etc., make the shapings on every second row (on each side of course).

(See below for more Pattern Stitch Symbols.)

PATTERN STITCH SYMBOLS



= knit stitch



= purl stitch



= empty needle (leave in working position)



= needle not used (in the out of work position)



= needle in the holding position



= Needles back into working position.



= 2 stitches on 1 needle — either transferred from the right side or the left side, then put the needle into holding position



= needle holding 2 stitches. Stitch has been transferred from the LEFT



= needle holding 2 stitches. Stitch has been transferred from the RIGHT



= 3 stitches on 1 needle. The 1st and 3rd stitch in a group of 3 needles has been hung on the 2nd or center needle.



= Center of Garment Section.



= Number of rows to be knitted between shapings.

The diagrams (Line Drawings) for pattern work are followed just as they are shown and are to be read as you look at them while knitting the garment.

open darts



closed darts





Knitking News

KNITKING MAGAZINE IN ENGLAND

We are very happy to announce that KNITKING MAGAZINE is now being sold in Great Britain and we say "Welcome to our British subscribers".... We hope that you will take the time to write and tell us of your likes and dislikes as do our friends in the U.S.A... KNITKING MAGAZINE is planned and designed to satisfy (as much as possible) the needs of each individual subscriber... So if you have a preference for certain types of garments or if there are things you do not fully understand in regards to our instructions, please let us know so that we can help satisfy your needs

England has become one of the worlds greatest markets for automatic knitting machines... It is importing and selling more than three times the number sold annually in the entire United States..! Most English Women still derive great pleasure in creating good looking clothes for herself and her family. Girls are taught to hand knit by their mothers and in school, at a very early age.. They progress to knitting machines and the more speedy production of knitted garments as soon as their pocket book allows.

KNITKING PATTERN READER

Our fabulous new accessory continues to sell as fast as we take deliveries from Europe... It will not be very long before the Pattern Reader becomes an indispensable tool... We are proceeding with the development of a system of garment chart drawing that can easily be used by any knitting machine owner... This new system will permit you to produce Pattern Reader Charts for any size and style of garment in practically any type or weight of yarn... We expect to go into greater detail about this in the next issue of KNITKING MAGAZINE. Meanwhile we have to tell you that the Introductory Price for the WHIZ KING Pattern Reader ends on August 31st. The retail price thereafter will be \$59.50.

OUR READERS WRITE

A number of letters are received in our office from subscribers with knitting machines other than KNITKING, asking about the terminology we use in KNITKING MAGAZINE Patterns which applies to KNITKING machines. We believe if we tell you exactly what our KNITKING Controls do, you can use whatever controls you have on your machine that will give you the same (or similar) Pattern or special effect. Of course, you MUST KNOW your own machine, the workings of the levers, buttons, etc., etc. So... for those of you who asked for it... and for others who might NEED it... here is a list of the KNITKING Controls and some parts of the machine as well as what they do....

NEEDLE BED: Section of machine which holds the the needles within grooves.

SINKERS: Holds the knitting down in place so that it cannot fall off the machine or be knocked off. To release the knitting from under the Sinkers (for binding off - or for transferring stitches) press down on the BACK of the Sinkers protruding in front of the front Needle Rail,

and pull the knitting from under the Sinkers as you do so. Japanese machines (with the exception of Genie) do not have Sinkers.

CAM BOX: Sometimes called a Slide, Carriage or Lock. This is moved back and forth across the needles in working position to produce the knitting.

RIGHT and LEFT RETRACTOR BUTTONS: On each side of the Cam Box. Does exactly what it says... retracts the needles - brings the needles which are in holding position, back into working position as you knit the NEXT ROW, but the needles DO NOT knit on that row (this means that you would push the Retractor Button in BEFORE knitting the 4th Row on a 4 Row Pattern Stitch). If the Cam Box is on the RIGHT, push in the Right Retractor Button and the holding position needles will move back to the working position as you knit the next row. The Retractor Buttons are used for the knitting of Holding Position Designs and other special effects when combined with the Cam Control Buttons.

RIGHT and LEFT CAM CONTROL BUTTONS: On each side on the handles of the Cam Box. These are used to place the stitches in a SAFE position. If BOTH Cam Control Buttons are pushed back and you knit 1 row, the stitches will knit and the needles will move back with the stitches remaining in the NEEDLE HOOKS. You can now move the Cam Box across either way and the stitches will remain in this position and it is the one used for ripping back any number of rows if you have made a mistake in your knitting. When ready to continue knitting, push the Cam Control Buttons forward (be sure the Cam Box is on the side OPPOSITE your yarn) and move the Cam Box without yarn, across the needles in work, and they will move back into the knitting position ready for you to continue knitting.

A combination of the Cam Control Buttons and the Retractor Buttons is used for the knitting of Norwegian Designs using two or more colors.

GATE CAM RELEASE LEVER: On the right hand side of the knitter Cam Box and on the left hand side of the Ribber. This is used for the knitting of special effects. It is normally set so that it is pointed toward the NEEDLE HEADS (the latches of the needles). When it is pushed BACK toward the NEEDLE HEELS (the butts of the needles), the next row is knitted, but the stitches will now sit ON TOP of the OPEN LATCHES of the needles, then when knitting the following row, the stitches will go behind the latches WITHOUT knitting this row.

Special designs are made by using a holding position for specific needles and with the Gate Cam Release Lever pointed to the Needle Heels on the knitter.

When using the KNITKING COORDINATED RIBBER and both the Gate Cam Release Levers of the Knitter and the Ribber are pushed back toward the needle heels, a Fisherman's Rib on both sides of the knitting is produced. When the Gate Cam Release Lever of the main machine is set to the Needle Heels, the Fisherman's Rib will be on the Purl

side and when the Lever on the Ribber is set to the Needle Heels, the Fisherman's Rib will be on the knit side.

PRACTICAL KNITTING HINTS

NEAT EDGES FOR A SHAPED COLLAR OR NECKBAND

To obtain neat edges when knitting shaped edges on a Ribbed Collar or Neckband, make the decreases of 2 sts. using the full fashion method. When you cast on, make sure (if the section on each side is shaped) that the 2 end sts. ON EACH SIDE are ALWAYS on the main machine. The Collar for MK 5418 in this issue, is knitted using this method. The first decreases on the Collar sections are made after Row 3. First, transfer the 3rd st. (which is always a Ribber stitch) to the main machine. Release the sts. from under the sinkers, hang the 3rd and 4th sts. onto the 2nd st., then move the end sts. inward to fill the empty needles. REPEAT for the other side. You now again have 2 sts. on each side on the main machine. REPEAT the decreases ON EACH SIDE, every 3rd row. When all 4 sections have been knitted in this manner, weave the edges together 1 st. in from each edge. You should have a beautifully finished Collar.

If only one edge of a section is to be shaped, as in the Neckband for Pattern DK 8185 in this issue, have 2 sts. on the main machine on the side where the shaping is to be made, then reverse the sides for the second section.

FRINGE for CAPE DK 8222

Cut the strands of yarn for the fringe 24" long. An easy way to measure and cut fringe is to cut a piece of cardboard 12" wide. Wind the yarn around the cardboard, then cut through the strands ON ONE SIDE ONLY. This will give you the 24" you need. Take 5 strands of yarn and fold them in half. With the wrong side of Cape facing you, and using a large crochet hook, pull the

folded loop through from the right side of Cape to the wrong side, then pull all the strands of yarn through the loop and pull up. Place each group of fringe approximately 3/4" to 1" apart. When you have attached all the fringe to the Cape take 5 strands from one group and 5 strands from the next group and make a knot about 1" down from the top. When you have completed this Row, make 2 more rows in the same way, taking 5 strands from one group and 5 from the next group, spacing the rows 1" apart. See picture on page 6.

OUR GIFT SECTION

Mrs. A. Schneider of Rochester, N. Y. designed and knitted the attractive and useful Golf Club Mitts KG 1961 in this issue. She sent us the Mitts and included the Pattern so that we might share it with our subscribers... Thank you so much Mrs. Schneider... we are sure our Readers will enjoy making them.

BOUND VOLUMES KNITTING MAGAZINE

This issue completes Volume No. 9, our first in Color. You can obtain Bound Volume No. 9 for \$7.95 plus 95¢ shipping. See AD on back of Editorial page.

We still have a few Bound Volume Nos. 6, 7 and 8. These are \$6.95 plus 95¢ shipping.

'MONOFIL'

Patterns DK 8221 and DK 8208 in this issue introduce our new nylon monofilament thread... 'Monofil' can be used as a secondary thread for lacy designs that otherwise would not hold their shape. Experiment using it as a second thread in any fancy stitch... You will obtain some interesting effects and have a lot of fun... It's very low in price \$2.95 (plus 40¢ shipping costs) for a spool holding 5468 yards... enough to make several garments. Be sure to keep the plastic sleeve on the spool and you will have no problem feeding MONOFIL.

ARE YOU UNHAPPY WITH YOUR PRESENT KNITTING MACHINE ?

DOES IT REFUSE TO KNIT FANCY DRESS YARNS?

DOES IT JAM UP WHEN YOU TRY TO KNIT LOOPED MOHAIR OR THICK AND THIN YARNS?

DOES IT DROP STITCHES ALL OVER THE PLACE?

ARE YOU CONTINUALLY HAVING TROUBLE WITH AWKWARD, CUMBERSOME WEIGHTS?

ARE YOU UNABLE TO MAKE A LARGE GARMENT WITH BULKY YARNS?

DO YOU HAVE TO SELECT PATTERN STITCHES MANUALLY?

DO YOU HAVE TO LATCH YOUR RIBBING BY HAND?

IF YOU ARE HAVING ANY OF THESE PROBLEMS YOU SHOULD TRADE UP TO A NEW FANTASTIC PUSH BUTTON KNITTING WITH COORDINATED RIBBER AND ENJOY KNITTING WITH THE WORLDS FINEST, MOST VERSATILE AND MOST AUTOMATIC KNITTER.

YOU WILL BE SURPRISED AT OUR GENEROUS TRADE-IN ALLOWANCE AND YOU CAN, IF YOU WISH, USE YOUR PRESENT MACHINE AS A DOWN-PAYMENT AND PURCHASE A COMPLETE KNITTING FOR JUST PENNIES A DAY. WRITE TODAY FOR FULL INFORMATION AND TELL US WHAT MACHINE YOU NOW OWN. THE ADDRESS IS:

KNITTING, Dept. T-1, 1128 Crenshaw Blvd., Los Angeles, Calif. - 90019

Another first from KNITKING

Completely Self-Contained Motorized Table for KNITKING machines (wired for 110 volts) . . . Just locate your KNITKING on the Table, no clamps or fixing necessary . . .

Simple to operate . . .

Foot and Fingertip controls.

Built in Safety Device stops machine if knitting jams . . .

Can be used with Ball or Cone Yarn.



List Price: \$349.00

Special Introductory Price: \$299.00

(California residents add 5% Sales Tax).

Freight charges — F.O.B. Los Angeles.

(Crated Table weighs approximately 100 pounds)

Order direct from KNITKING — 1128 Crenshaw Blvd., Los Angeles, California 90019

