

16-1

knitking

magazine



DK 879



KK 877



DK 875



DK 886



DK 882

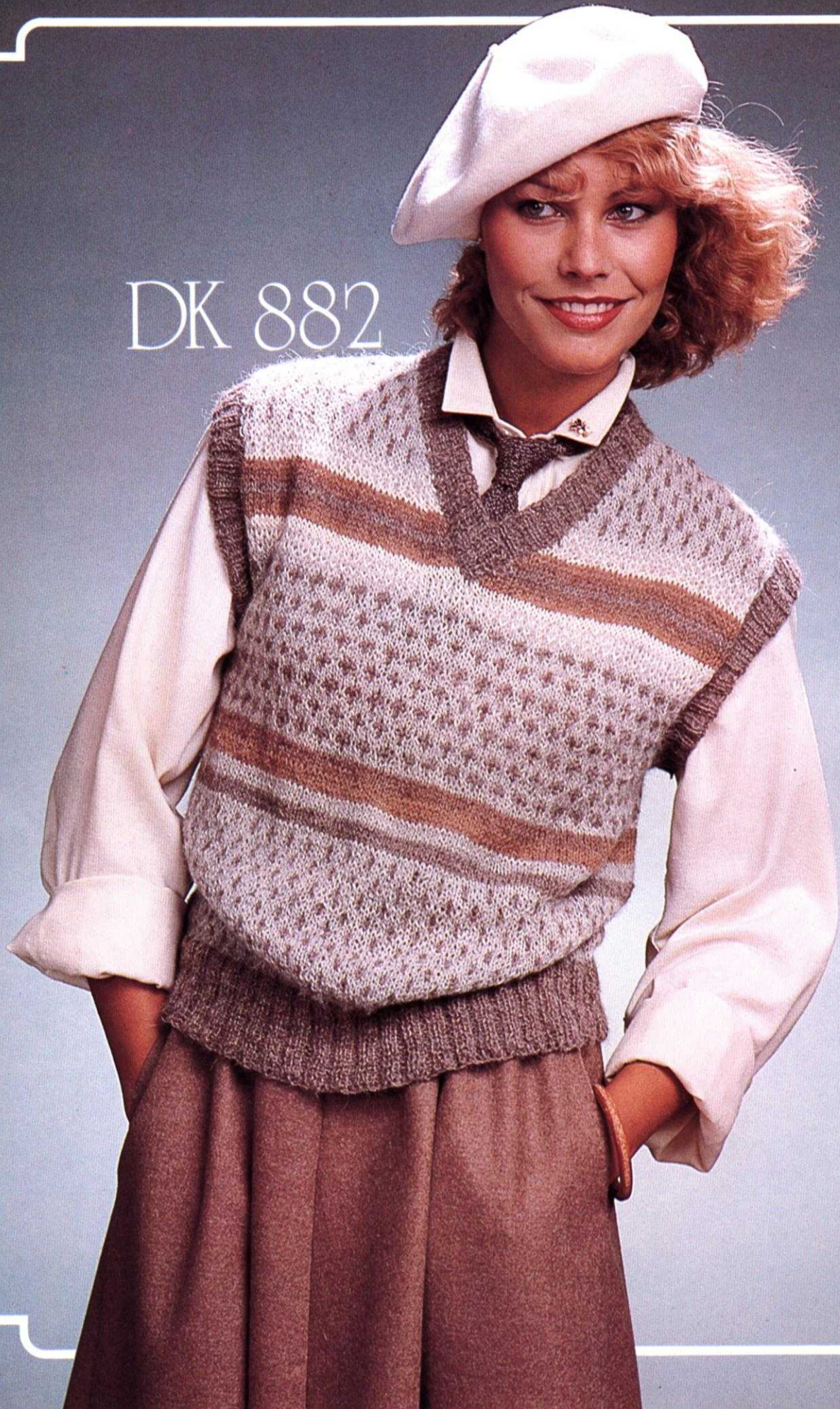



DK 884

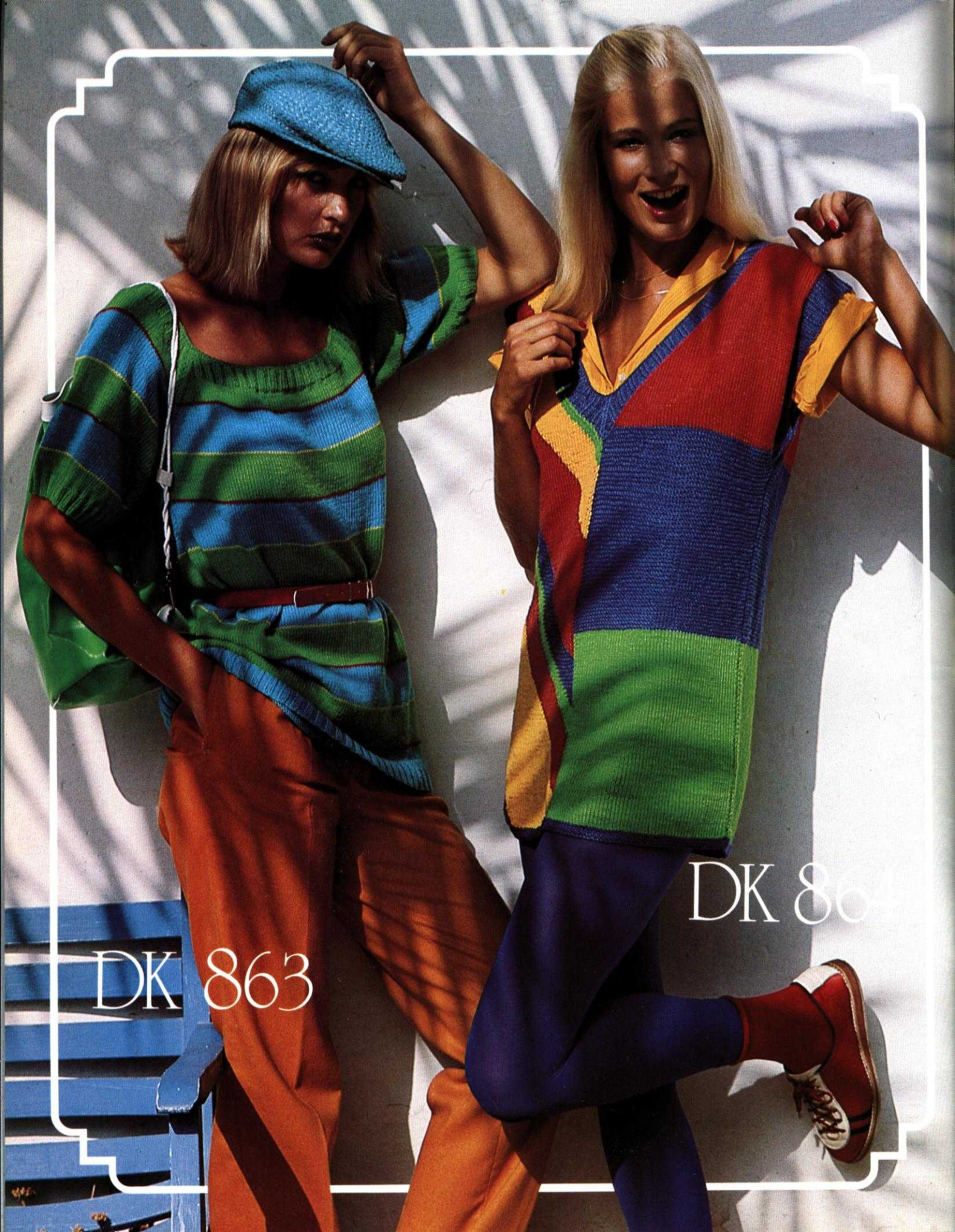

DK 863

DK 864

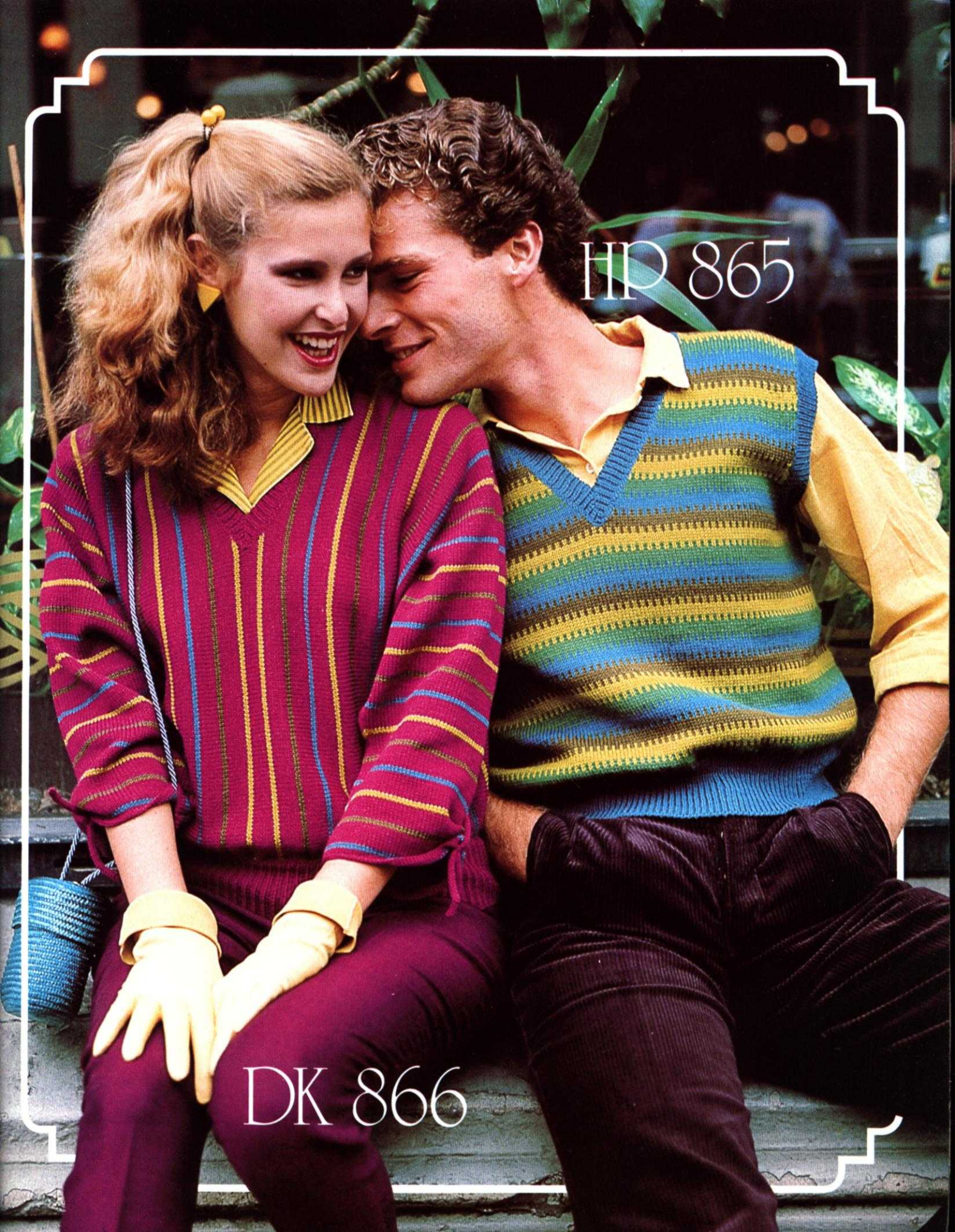

HP 865

DK 866

DK 880



VOLUME 16, NO. 1

knitking

magazine

TABLE OF CONTENTS

PAGE NO.

| | | |
|--------|------------------------------------|----|
| DK 863 | Woman's Pullover | 14 |
| DK 864 | Woman's Pullover | 14 |
| HP 865 | Man's Vest | 15 |
| DK 866 | Woman's Pullover | 16 |
| KK 867 | Girl's Pullover | 16 |
| KK 868 | Boy's Pullover | 17 |
| KK 869 | Child's Pullover | 18 |
| KK 870 | Child's Pullover with Embroidery | 19 |
| KK 871 | Child's Pullover | 20 |
| KK 872 | Child's 2-Piece Suit | 22 |
| KK 873 | Toddler's Suit | 21 |
| HP 874 | Man's Pullover | 24 |
| DK 875 | Woman's Pullover | 23 |
| DK 876 | Woman's Pullover | 25 |
| KK 877 | Teenager's Dress | 25 |
| KK 878 | Child's Jacket | 28 |
| DK 879 | Woman's 2-Piece Suit | 29 |
| DK 880 | Woman's Pullover | 31 |
| KK 881 | Girl's Bib Jumper | 32 |
| DK 882 | Woman's Vest | 32 |
| KK 883 | Child's Pullover | 34 |
| DK 884 | Woman's Pullover | 34 |
| DK 885 | Woman's Jacket & Skirt | 36 |
| DK 886 | Woman's Pullover | 35 |
| DK 887 | Woman's Twin Sweater Set | 38 |
| KK 888 | Girl's Dress | 37 |

editorial

KNITKING CORPORATION has been selling knitting machines for over 25 years and we remember well how amazed and fascinated we were at the sight of our first automatic knitter... It knitted so fast that we coined the phrase "Faster Than a Hundred Hands" and we used the slogan for many years in our advertising... Yarn was laid across the needles by hand, pattern stitch selection was also done manually... Incredible then, but primitive by modern knitting machine standards ... and now we have the incomparable COMPUKNIT KH 910!

The tremendous advances made during the past decade in computer design and techniques, plus the miniaturization of components and the introduction of printed circuitry have been truly incredible... It is just a few short years since we first read about computer chips and forecast that one day they would be used to control the operation of knitting machines... We never dreamed that development would be so rapid.

It is here now...! The COMPUKNIT KH 910, an electronic knitting machine with a built in computer... You program it yourself with remarkable simplicity... It functions through pictures as opposed to Punch Cards and there is literally no limit to the designs and stitches that can be made on it... Lace designs can be up to 120 stitches wide, either in normal or fine lace... all of the 840/830 accessories, the Ribbing Attachment, the Four Color Changers and the Knitleader fit the KH 910

There are many beautiful designs supplied with the KH 910. Additionally, you can trace or draw your own... We are planning to include new and original illustrations in KNITKING MAGAZINE for you to duplicate on the blank sheets supplied with each machine.

We are so enthusiastic about the Compuknit KH 910 that we could fill several pages of this magazine telling you how marvelous it is but our editorial space is limited and you will read more about it on some other pages... We will however repeat a slogan used by us for many years with another model of knitting machine: "It's Fast... It's Easy... and It's Fun...".















We encourage every knitting machine owner to trade up or add a COMPUKNIT KH 910 to their present equipment. To do so is to enter a whole new and exciting world of creative knitting.











Publisher: KNITKING CORPORATION, 1128 Crenshaw Blvd., Los Angeles, Calif. 90019. Telephone: (213) 938-2079. Published bi-monthly. Subscriptions: USA — \$15.00 annually, single copies \$4.00; Canada — \$18.00; other parts of the world — \$20.00. The entire contents of KNITKING MAGAZINE are copyright and must not be reproduced in any shape or form without the express permission, in writing of the publisher. ©COPYRIGHT 1980 by KNITKING CORPORATION.





Pattern Symbols

Knitting – Chart Symbols









- () Size Symbols (2nd Size)
- < > 3rd Size
- ① Color Number
-  Cast on
-  Stitch
- R Row
- H Hem
-  Bind off
-  Stockinette stitch – worn on the Knit side.
-  Stockinette stitch – worn on the Purl side.
-  Knit 1, Purl 1 Ribbing
-  Ribbing Pattern – worn on the Knit side.
-  Ribbing Pattern – worn on the Purl side.
-  Closed Dart
-  Open Dart
-  Put on a stitch holder
-  Reverse 1 section
-  On every other needle
-  Number of Rows between Shapings. Make increase (or decrease) FIRST, then knit 4 rows. For example: 3 x 1  means decrease (or increase) 1 st., knit 4 rows; decrease 1 st., knit 4 rows; decrease 1 st., knit 4 rows; decrease 1 st., knit 4 rows. All decreasing (or increasing) without row numbers as shown must be shaped on every 2nd row.

-  Increase
 -  Increase 2 sts. With a transfer tool, move the sts. over the left (or right) leaving 2 empty needles at the point of increase. At the increase point, move 1 st. to the left, (or right) so that there is an empty needles on each side of a stitch. On each side of the center stitch, pick up a stitch from the row below and hang it onto the empty needle.
 -  3 stitches on 1 needle. The 1st and 3rd stitch in a group of 3 has been hung on the 2nd or center needle.
 -  Short Row increase or decrease; for instance on a flared skirt knitted sideways.
 -  Pattern Stitch
 -  Pattern Stitch – worn on the Knit side.
 -  Pattern Stitch – worn on the Purl side.
 -  Repeat
- I = Front
 - II = Back
 - III = Sleeve
 - IV = Skirt Front
 - V = Skirt Back
 - VI = Collar
 - VII = Pocket
 - VIII = Band
 - IX = Belt
 - X = Cuff
 - XI = Pants Front
 - XII = Pants Back

Finishing – Chart Symbols

-  Match numbers on section for assembling.
-  Ease
-  Fold Line
-  Turn to the wrong side and hem.

Stitch Symbols

-  Needles in holding position
-  Needles back into working position.
-  Empty needle (leave in working position)
-  Needle not used (in the out of work position).
-  Two stitches on 1 needle, either transferred from the right side or the left side, then put into holding position.
-  Needle holding 2 stitches. Stitch has been transferred from the RIGHT.
-  Needle holding 2 stitches. Stitch has been transferred from the LEFT.
-  Center of garment section



General Instructions

HOW TO READ THE CHARTS AND INSTRUCTIONS

There are 3 sizes given for each Pattern in KNITKING MAGAZINE. Above each Chart for the different sizes, you will see that the first and smaller sizes might be shown as 8/10, the second size as [12/14] and the third as [16/18]. Check the measurements at the bustline and hips on the Charts to be certain that you will knit the correct size, remembering these are ACTUAL measurements of the completed section and that there must be a bigger allowance at the bustline and hipline for a Jacket or a Coat than there would be for a fitted dress or a fitted blouse or pullover. The question in your mind should be "How do I want this garment to fit...?"

When you have chosen the size you need, you can follow the Charts as shown. You will notice that where the shapings are the same FOR ALL SIZES, only 1 set of shapings will be shown on the first Chart and if you are knitting the 2nd or 3rd size, you simply follow the shapings as given for the first size. If the shapings are different, this will be shown on the Charts and you should follow them as given.

On the Charts, increases and decreases will be shown as follows

5×1
[6] The number in the box means number of ROWS between the shapings, while the 5×1 above the box means - 1 st. $5 \times \dots$ so you will increase or decrease 1 st. every 6th row $5 \times$.

ARMHOLE SHAPINGS - NECK SHAPINGS - SHOULDER SHAPINGS - are made on every 2nd row UNLESS there is a number in a box along side or below the shapings. The rule is... where there is no box with a number, the shaping is made on every 2nd row.

THE PRINTED INSTRUCTIONS

You can follow the printed instructions or use them in combination with the Charts. Where there is any question in the printed instructions, you have the Charts to show you how the section will look.

The 3 sizes, with the different amounts of cast on stitches and the different shapings will look like this...

Cast on 124 (136) [148] sts. You will
Cast on 124 sts. for the first size.
Cast on 136 sts. for the 2nd size.
Cast on 148 sts. for the 3rd size.

The important thing to remember is that you MUST READ AHEAD so that you KNOW what to do for the size you are knitting. Sometimes where the number of stitches are the same but the number of times different, you will find shapings like this...
3 sts. 1x (2x) [3x], 2 sts. 1x (2x) [3x], 1 st. 3x (4x) [5x].
As you see, you MUST read ahead in order to follow the instructions as given for YOUR SIZE. The rows will be different for the different sizes in some cases... Shoulder and Neck shapings usually are worked at the SAME TIME for the back section - so watch for the words AT THE SAME TIME.

HOLDING STITCHES ON THE LEFT SIDE WHILE SHAPING THE RIGHT SIDE

When knitting a section of garment in stockinette stitch, it is easy to hold the stitches on the left side while knitting the right half, but when knitting a Pattern Stitch such as a Norwegian Design, a Holding Position Design, Weaving, etc., you should use the following method. For the NECK SHAPING, we tell you to bind off the center sts., put the needles on the left into holding position and complete the right half first... so with a strand of contrast yarn, knit ALL of the left side stitches manually by hand, pulling each stitch back against the needle bed to the OUT OF WORK position. When the right side is completed, carefully pull the stitches held on contrast, forward into working position and as you do so, undo the contrast yarn, line up the needles (KNITKING AM 3 machine owners, put the stitches under the sinkers) and complete the left half.

If you own a Japanese machine, you may find that when knitting the right half with the left side held in this way, the sinker plate will mark the left side while you are knitting the right half. To prevent this marking, you can tape a piece of paper over the knitting, underneath the sinkers, or if you own a Reversing Bar, you can hang this onto the Sinkers while you are knitting the right half. When hanging the Reversing Bar, be sure the eyes of the bar go BETWEEN the Sinker Posts on the upper part of the bar so that the tips of the bar only - show above the needle bed.

FULL FASHION DECREASING OR INCREASING

For Stockinette stitch, always use the Full Fashion method for increasing or decreasing.

TO DECREASE: Hang the 3rd stitch onto the 2nd stitch then move the stitches in to fill the empty needle.

TO INCREASE: Move the 2 end stitches 1 needle outward, then pick up the 3rd stitch from the row below and hang it onto the empty needle.

FINISHING: Block all sections. For PULLOVERS, JACKETS, and DRESSES: Join front to back at sides and shoulders. Sew sleeves together and set in. Hem lower edge and sleeve edges if needed. For a double neckband or armhole band, sew 1 edge to the inside and 1 to the outside of neck or armhole. For a single ribbed band, sew 1 edge to the outside of neck or armhole edge. For a cardigan or jacket with buttonholes, finish buttonholes and sew on buttons.

PANTS: Join front to back at sides. Sew inside leg seams, then join center front and back. Make hem at waistline and insert elastic. Hem lower edge of pants legs.

THE SAMPLE SWATCH

Before you begin to knit any garment, you will need to knit a sample piece using the yarn you have chosen for your garment, so that you can check the stitch and row gauge which must measure the correct number of stitches and rows in 5 cm (2 inches).

For each Pattern in KNITKING MAGAZINE, we give you 3 tension numbers to work from and if you use the specified yarn for the garment, you should be able to get the correct stitch and row gauge using one of these numbers. Here is a very easy way to make your sample swatch and count the stitches and rows without actually counting, by using our KNITKING Converta Tape.

Supposing the Tension Numbers for the Stitch and Row Gauge are given as 5 to 7. Set the Tension Dial to the first number which is 5. With contrast waste yarn, and using the quick cast on method, cast on 60 stitches and knit 10 rows. Change to garment yarn and turn the Row Counter to 0. Knit 30 rows. Counting from each end, knit the 10th stitch on each side by hand with a small piece of contrast yarn. Leave the needles in working position and knit 30 rows (Row 60), then knit 4 rows with contrast waste yarn. Turn the Row Counter to 0 and the Tension Dial to 6 and with garment yarn, knit 30 rows. Mark the 10th stitch on each side as you did before, knit 30 rows, then 4 rows with contrast waste yarn. Turn the Row Counter to 0 and with Tension 7, repeat the above once more, ending with 10 rows of contrast waste yarn. Remove the work from the machine by passing the Slide across the needles without yarn (sometimes called 'dropping'). Pull and stretch the sample piece both lengthwise and diagonally from corner to corner, then lengthwise again. Do not count the stitches and rows immediately, but allow the sample to rest for several hours or even over night. This will allow the stitches and rows to return to their basic form.

When your sample has rested and you are ready to count the stitches and rows, the KNITKING CONVERTA TAPE will do the counting for you without any counting on your part. Use the Tape as follows:

Measure the stitches with the TAPE, BETWEEN the 40 stitches marked with contrast waste yarn. Push the SLIDE so that the LEFT EDGE lines up to this exact measurement. Now look down along side the SLIDE and find the number 40 on the TAPE. The number directly opposite on the SLIDE will be your Stitch Gauge to 5 cm (2"). To find the number of rows in 5 cm (2"), place the TAPE to measure over the 60 rows, push the SLIDE to this number with the left edge lined up, the look for the number 60 on the TAPE and directly opposite this will be the number of rows to 5 cm (2")

If you do not own a KNITKING CONVERTA TAPE, you must mark a 5 cm (2 inch) square in the center of the knitting, then count the number of stitches and rows within the square.

DK 863

WOMAN'S PULLOVER

SIZES: 10/12 (14)
 YARN: Amore
 GRAMS:
 color 1 50 50
 color 2 50 50
 color 3 100 100
 color 4 50 50
 TENSION: 6 to 8
 GAUGE: 12 sts. 17 1/2 rows = 5 cm (2")

Stockinette stitch with color stripes as shown on the Chart. Bands are K2, P2 Ribbing.

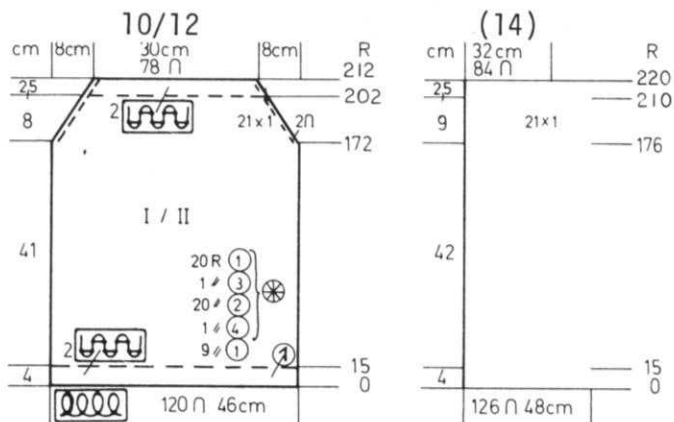

BACK & FRONT: 2 sections the same.

FINISHING: See General Instructions.

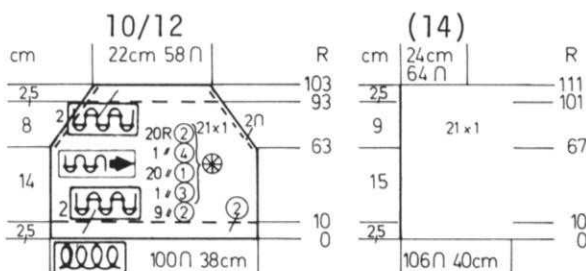

SLEEVES: III

Cast on 100 (106) sts, with color 1 and work 10 rows ribbing. Continue in Stockinette stitch with color stripes as shown on the Chart. After Row 63 (67) SHAPE THE RAGLAN same as the front and back and after Row 93 (101), continue in Ribbing. After Row 103 (111), bind off.

Cast on 120 (126) sts. with color 1 and work 15 rows Ribbing. Continue in Stockinette stitch with color stripes as shown on the Chart. After Row 172 (176), SHAPE RAGLAN using the full fashion method. Use 3 needle transfer tool and ON EACH SIDE, decrease 2 sts. then decrease 1 st. every 2nd row 21x. (Decrease 1 st. every 2nd row 21x). AT THE SAME TIME, after Row 202 (210) continue in Ribbing. After Row 212 (220), bind off.

DK 864

WOMAN'S PULLOVER

SIZES: 12
 YARN: Amore
 GRAMS:
 color 1 150
 color 2 150
 color 3 Few yards
 color 4 Few yards
 TENSION: 5 to 7
 GAUGE: 13 sts. 19 rows = 5 cm (2")

Stockinette stitch with color stripes as shown on the Chart. Neck and Armbands are ribbed.

FINISHING: See General Instructions.

NOTE: The back and the left front are worked in Stripes with color changes and the knitting is REVERSED as shown. The RIGHT FRONT is worked in bias and each stripe is worked separately using SHORT ROWS.

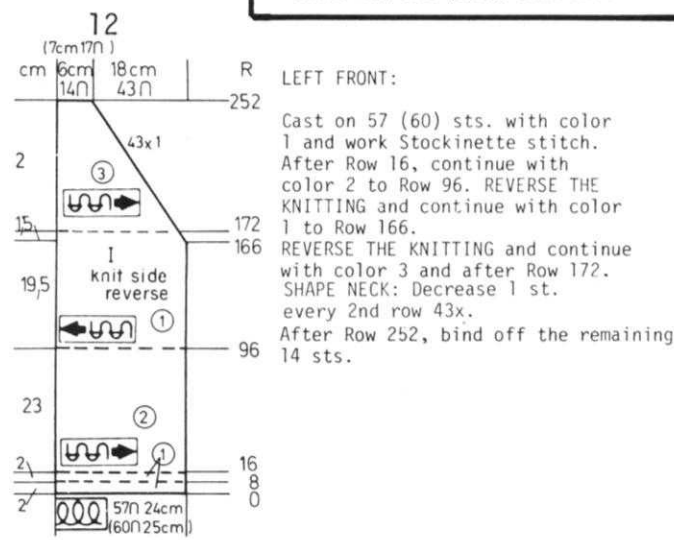

LEFT FRONT:

Cast on 57 (60) sts. with color 1 and work Stockinette stitch. After Row 16, continue with color 2 to Row 96. REVERSE THE KNITTING and continue with color 1 to Row 166. REVERSE THE KNITTING and continue with color 3 and after Row 172. SHAPE NECK: Decrease 1 st. every 2nd row 43x. After Row 252, bind off the remaining 14 sts.

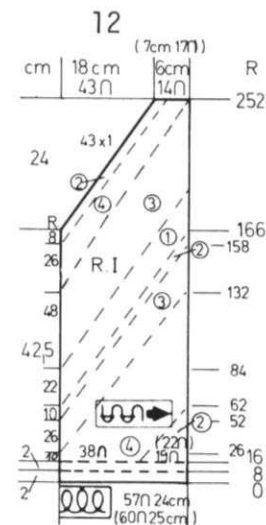

RIGHT FRONT: I

Cast on 57 (60) sts. with color 1 and work 16 rows Stockinette stitch. BEGIN THE BIAS STRIPES. Put 38 sts. on the left side into holding position, then work SHORT ROWS over the 19 (22) sts. ON THE LEFT, on every 2nd row, put into holding position 1 st. to Row 52. Leave all these sts. in holding position and begin the 2nd stripe. Bring the 38 needles on the left into working position. Slide on the left, Counter at 16 and with color 4, bring 1 needle on the right back into working position and when Slide is on the right, put 1 needle on the left into holding position.

After Row 132, all the sts. will be in holding position. Begin again on the left side. Row Counter 26. and using color 3, bring 1 st. on the right into working position and 1 st. on the left into holding. Continue in this way for all the stripes, following the Chart. The last stripe is in color 2 on Row 158 and begin the neck shaping on Row 166. For neck, decrease 1 st. every 2nd row 43x. The last 2 stripes end at Row 252. Bind off the last 14 sts when completing the last stripe.

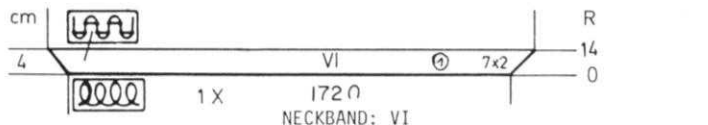

NECKBAND: VI

Cast on 172 sts. with color 1 and work in Ribbing. ON EACH SIDE, increase 2 sts. 7x. After Row 14, bind off.

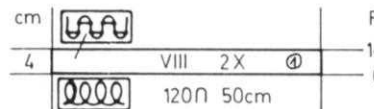

ARMBANDS: VIII Make 2.

Cast on 120 sts. with color 1 and work 14 rows Ribbing. Bind off.

12

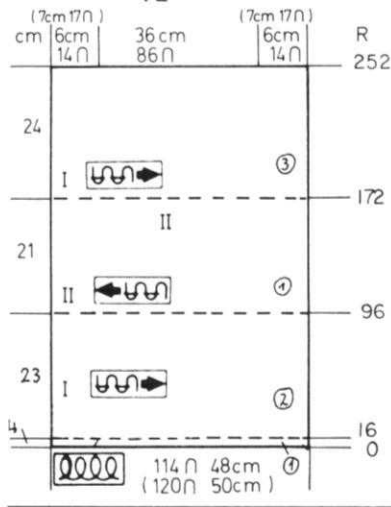

BACK: II

Cast on 114 (120) sts. with color 1 and work 16 rows Stockinette stitch. Continue with color 2.
Knit to Row 96, then REVERSE THE KNITTING. Continue with Color 1 to Row 172.
REVERSE THE KNITTING and continue with color 3.
After Row 252, bind off the 14 shoulder sts. on each side then bind off the 86 center sts. or you can remove them onto different colored waste yarn.

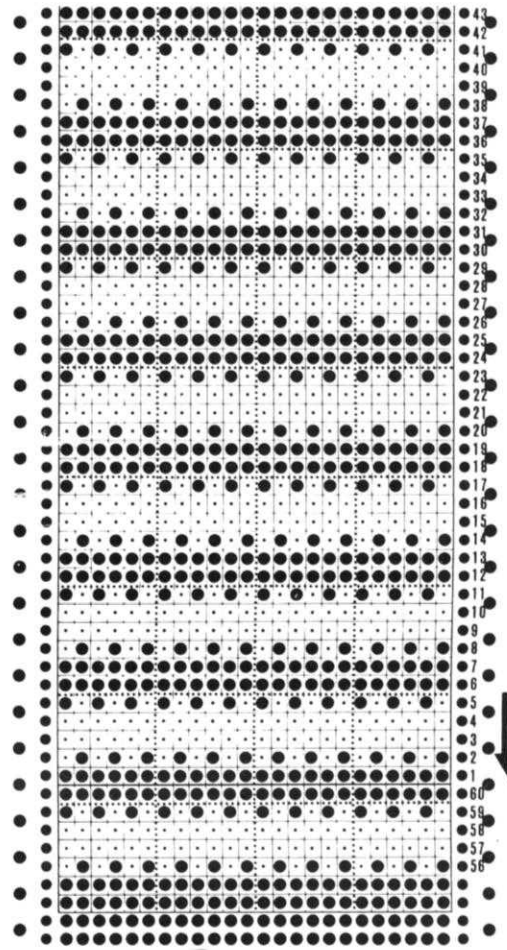

HP 865

MAN'S VEST
 SIZES: 38/40 (42/44)
 YARN: Vienna
 GRAMS: color 1 100 150, color 2 50 50, color 3 50 50, color 4 50 50
 TENSION: 6 to 8
 GAUGE: 14 sts. 17 rows = 5 cm (2")

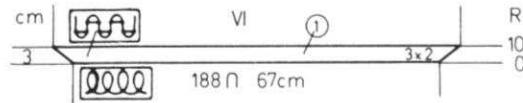

NECKBAND: VI
 Cast on 188 sts. with color 1 and work in Ribbing.
 ON EACH SIDE, increase 1 st. every 2nd row 3x.
 After Row 10, bind off or remove onto waste yarn.

A Stripe Pattern in a Norwegian Design. Punch your own Card. Bands are K1, P1 Ribbing.

FINISHING: See General Instructions.

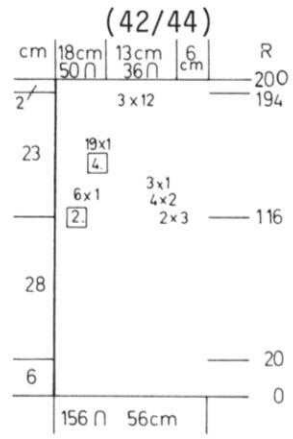
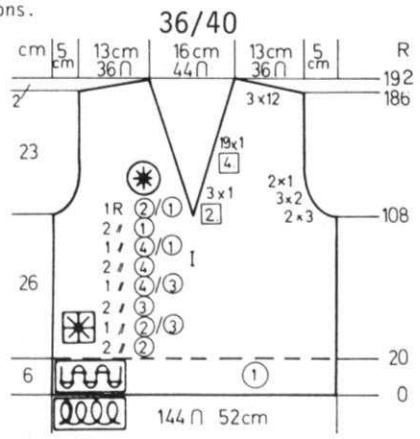

FRONT: I
 Work the front the same as the back to Row 108 (116).
 Divide in the center. Put the needles on the left into holding position and complete the right side first.
 *SHAPE SHOULDER same as the back and ON NECK SIDE, bind off 1 st. every 2nd row 3x (6x), then 1 st. every 4th row 19x.
 After Row 186 (194), SHAPE SHOULDER same as the back.
 Bring the needles on the left into working position, knit 1 row in Pattern to the left side, turn the Row Counter back to 108 (116) and complete the left half. Follow the instructions from *.

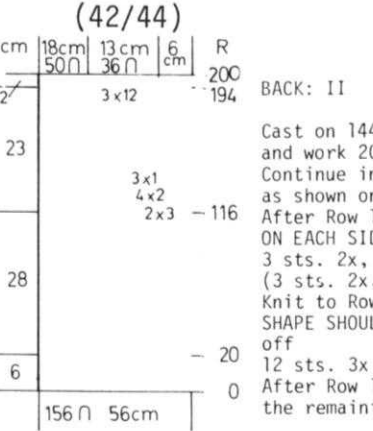
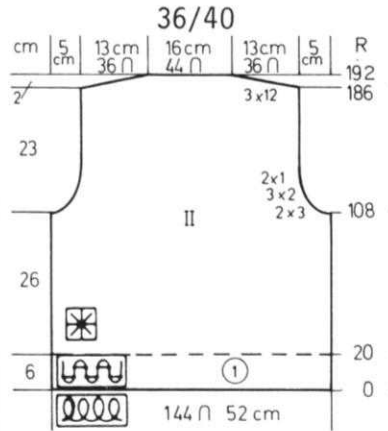

BACK: II
 Cast on 144 (156 sts. with color 1 and work 20 rows Ribbing.
 Continue in Pattern with color changes as shown on the front Chart.
 After Row 108 (116) SHAPE ARMHOLE: ON EACH SIDE, bind off 3 sts. 2x, 2 sts. 3x, 1 st. 2x. (3 sts. 2x, 2 sts. 4x, 1 st. 3x).
 Knit to Row 186 (194).
 SHAPE SHOULDER: ON EACH SIDE, bind off 12 sts. 3x for both sizes.
 After Row 192 (200), bind off the remaining sts.

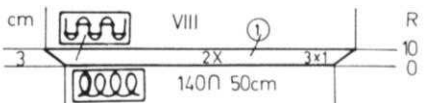

ARM BANDS: VIII Make 2.
 Cast on 140 sts. with color 1 and work in Ribbing.
 ON EACH SIDE, increase 1 st. every 2nd row 3x.
 After Row 10, bind off or remove onto waste yarn.

DK 866



WOMAN'S PULLOVER

SIZES: 8/10 (12)
 YARN: Fortissima
 GRAMS:
 color 1 300 350
 color 2 50 50
 color 3 50 50
 color 4 50 50
 TENSION: 6 to 8
 GAUGE: 13 1/2 sts. 19 rows = 5 cm (2")

Stockinette with color stripes and knitted sideways on the machine. Waist and Neck Bands are K1, P1 Ribbing.

FINISHING: See General Instructions. Leave opening on sleeve seam for Cord. Make 2 cords 24 cm long. Pull through opening.

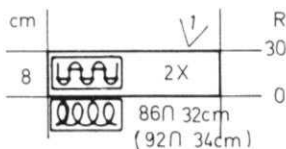

WAISTBANDS; Make 2.

Cast on 86 (92) sts. with color 1 and work 30 rows Ribbing. Bind off or remove onto waste yarn.

KK 867

GIRL'S PULLOVER

SIZES: 5/6 (8/10)
 YARN: Euro Sport
 GRAMS:
 color 1 250 300
 color 2 50 50
 color 3 50 50
 color 4 50 50
 TENSION: 7 to 9
 GAUGE: 13 sts. 18 rows = 5 cm (2")

BE SURE TO READ PRINTED INSTRUCTIONS. The front is knitted in Stockinette stitch with Short Rows to form the pattern and with changes in color. The back and sleeves are Stockinette stitch. All Bands are ribbed.

FINISHING: See General Instructions.

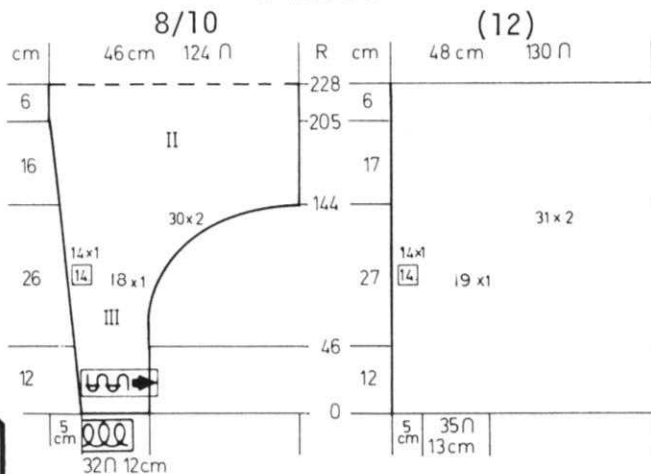

BACK: II

Cast on 110 (114) sts. with color 1 and work 22 rows K1, P1 Ribbing. Continue in Stockinette stitch. After Row 101 (109), mark each side for setting in sleeves. Knit to Row 166 (174). SHAPE SHOULDERS: ON EACH SIDE BIND OFF 13 sts. 1x, 12 sts. 2x. (13 sts. 3x). After Row 172 (182), bind off the remaining sts.

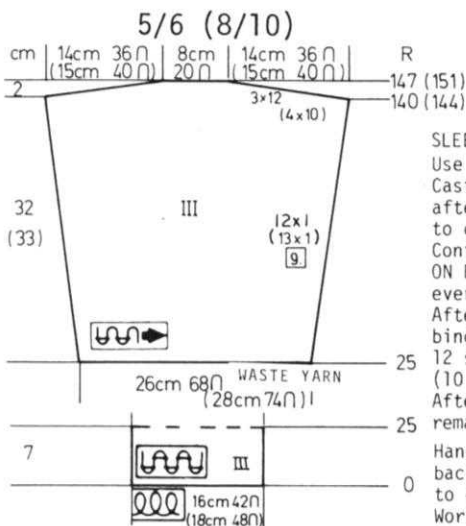

SLEEVES: III

Use open cast on with waste yarn. Cast on 68 (74) sts. and after knitting 8 to 10 rows, change to color 1 and put Counter at 26. Continue in Stockinette stitch. ON EACH SIDE increase 1 st. every 9th row 12x (13x). After Row 140 (144), ON EACH SIDE, bind off 12 sts. 3x. (10 sts. 4x). After Row 147 (151), bind off the remaining sts. Hang the sts. held on waste yarn back onto the machine, decreasing to 42 (48) sts. Work 26 rows Ribbing with color 1. Bind off.

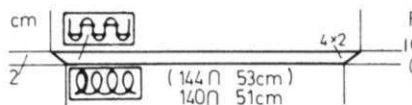
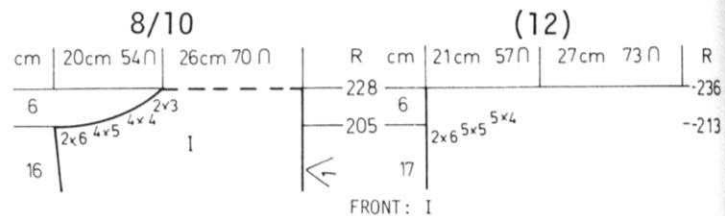

NECKBAND:

Cast on 140 (144) sts. with color 1 and work in Ribbing. ON EACH SIDE, increase 2 sts. 4x. After Row 10, remove onto waste yarn or bind off.

Work the front the same as the back to Row 205 (213). SHAPE NECK: Bind off 6 sts. 2x, 5 sts. 4x, 4 sts. 2x, 3 sts. 2x. (6 sts. 2x, 5 sts. 5x, 4 sts. 5x). After Row 228 (236) Mark each side for center front then WORK BACKWARDS, REVERSING THE SHAPINGS.

BACK: II

Cast on 32 (35) sts. with color 1 and work Stockinette stitch with color stripes as follows:
 2 Rows color 1
 *2 Rows color 2
 8 rows color 1
 2 rows color 3
 8 rows color 1
 2 rows color 4
 8 rows color 1
 REPEAT FROM * FOR PATTERN. After Row 46, ON THE LEFT, increase 1 st. every 14th row 14x AND AT THE SAME TIME, ON THE RIGHT increase 1 st. every 2nd row 18x (19x), then cast on 2 sts. 30x (31x). After Row 205 (213), mark the left side for neck. After Row 228 (236), mark each side for center of back then REVERSE THE INSTRUCTIONS for 2nd half.

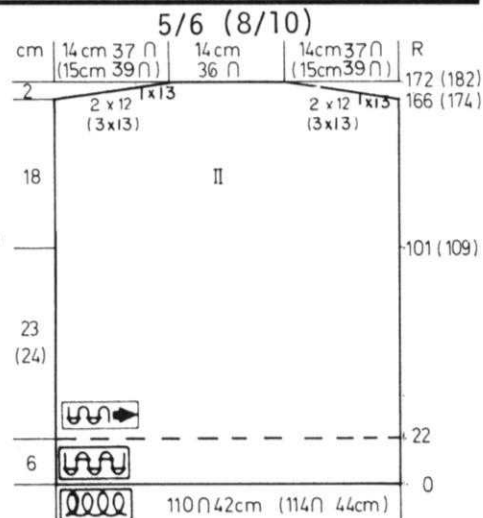

5/6 (8/10)

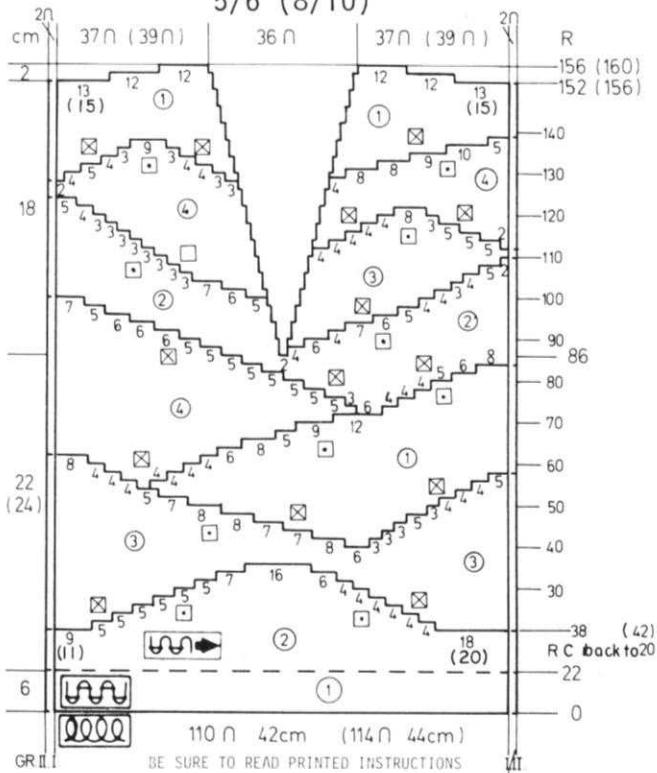

FRONT: I

Cast on 110 (114) sts. with color 1 and work 22 rows Ribbing.
Continue in Stockinette stitch with color 2.
After Row 38 (42) begin the SHORT ROWS.
ON OPPOSITE SIDE OF SLIDE, put into holding position, 9 (11) sts. Knit across, then ON OPPOSITE SIDE OF SLIDE, put into holding position 18 (20) sts. and knit across.
Now FOLLOW THE CHART, continuing the Short Rows as given. The numbers along side the chart are only a guide to help you know where you are as you are knitting the different sections. When you have completed the first Short Row Section, put the center 16 sts. into holding (the rest of the sts. on each side are already in holding) position.

TURN THE ROW COUNTER BACK TO 20 and with color 3, work the right side, bringing back the sts. as shown on the Chart. When the right section is completed, work the left section. Continue in this manner for all Short Row sections, following the Chart for the knitting and changing of colors.
After Row 86, put half the sts. into holding position and complete the right side first. Continue with the Short Rows as given.
After Row 152 (156), SHAPE SHOULDER: Bind off 13 (15) sts. 1x, 12 sts. 2x. Bring the needles on the left into working position as shown, turn the Row Counter back to 86 and complete the left half.

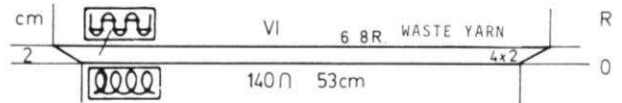

NECKBAND: VI

Cast on 140 sts. with color 1 and work K1, P1 Ribbing.
ON EACH SIDE, increase 2 sts. every 2nd row 4x.
After Row 10, remove onto contrast waste yarn.

KK 868



BOY'S PULLOVER

SIZES: 5/6 (8/10)
YARN: Euro Sport
GRAMS:
color 1 250 300
color 2 50 50
color 3 50 50
color 4 50 50
TENSION: 7 to 9
GAUGE: 13 sts, 18 rows = 5 cm (2")

BE SURE TO READ PRINTED INSTRUCTIONS.
The front is knitted in Stockinette stitch with Short Rows to form the pattern and with changes in color.
The back and sleeves are Stockinette stitch. All Bands are K1, P1 Ribbing.

5/6 (8/10)

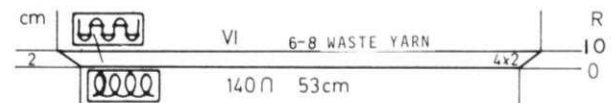
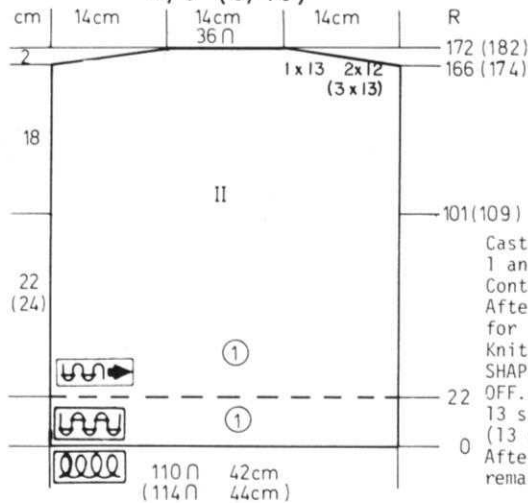

NECKBAND: VI

Cast on 140 sts. with color 1 and work K1, P1 Ribbing.
ON EACH SIDE, increase 2 sts. every 2nd row 4x.
After Row 10, remove the sts. onto contrast waste yarn.



5/6 (8/10)

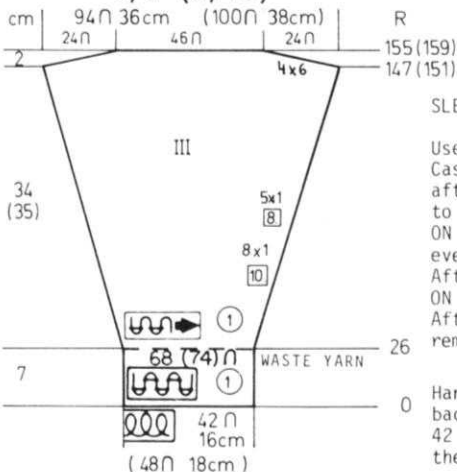

SLEEVES: III

Use open cast on with waste yarn. Cast on 68 (74) sts. and after knitting 8 to 10 rows, change to color 1 and put Counter at 26.
ON EACH SIDE, increase 1 st. every 10th row 8x, every 8th row 5x.
After Row 147 (151) SHAPE SHOULDER: ON EACH SIDE, bind off 6 sts. 4x.
After Row 155 (159), bind off the remaining sts.

Hang the sts. held on waste yarn back onto the machine decreasing to 42 (48) sts. Work 25 rows Ribbing then bind off.

KK 868

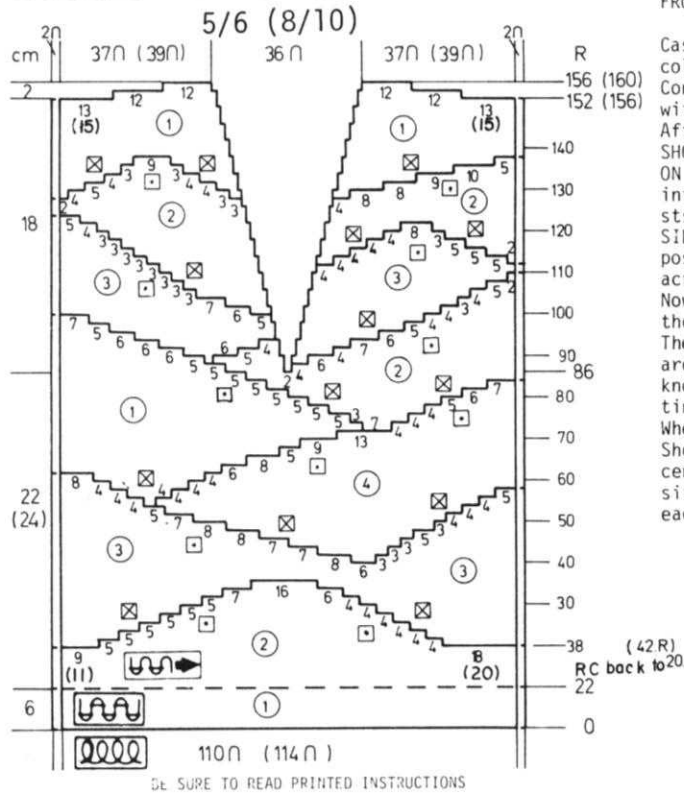

FRONT: I

Cast on 110 (114) sts. with color 1 and work 22 rows Ribbing. Continue in Stockinette stitch with color 2. After Row 38 (42), begin the SHORT ROWS. ON OPPOSITE SIDE OF SLIDE, put into holding position, 9 (11) sts. Knit across, then ON OPPOSITE SIDE OF SLIDE, put into holding position, 18 (20) sts. and knit across. Now FOLLOW THE CHART, continuing the Short Rows as given. The numbers along side the chart are only a guide to help you know where you are as you are knitting the different sections. When you have completed the first Short Row Section, put the center 16 sts. into holding position (the rest of the sts. on each side are already in holding).

TURN THE ROW COUNTER BACK TO 20 and with color 3. work the right side, bringing back the sts. as shown on the Chart. When the right section is completed, put these sts. into holding position and work the left section. Continue in this manner for all Short Row sections, follow the Chart for the knitting and changing of colors. After Row 86, put half the sts. into holding position and complete the right side first. Continue with the Short Rows as given. After Row 152 (156), SHAPE SHOULDER: Bind off 13 (15) sts. 1x, then 12 sts. 2x. Bring the needles on the left into working position as shown, turn the Row Counter back to 86 and complete the left half.

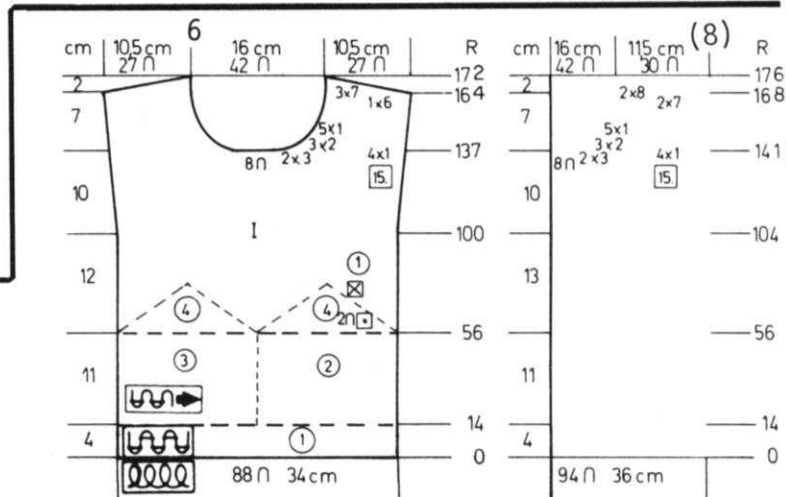

KK 869

CHILD'S PULLOVER

SIZES: 6 (8)
YARN: Vienna
GRAMS:
color 1 150 200
color 2 50 50
color 3 50 50
color 4 50 50

Plus small amounts of other colors not included in Kit.
TENSION 5 to 7
GAUGE: 13 sts. 18 1/2 rows = 5 cm (2")

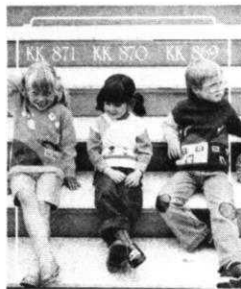

Stockinette stitch with Design on the front section only. Work top of houses using SHORT ROWS. The bands are K1, P1 Ribbing.

FINISHING: See General Instructions. Embroider smoke as shown on Picture as well as outline of windows.

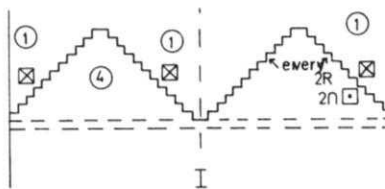
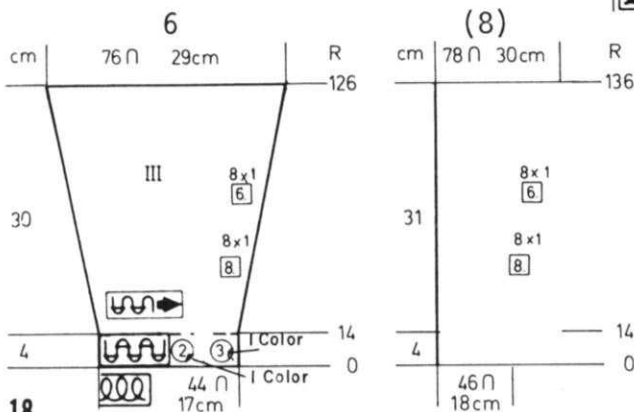

COLLAR: VI

Cast on 124 sts. with color 1 and work 30 rows Ribbing. Bind off.

SLEEVES: III Make 1 with color 2 and 1 with color 3. Cast on 44 (46) sts. and work 14 rows Ribbing. Continue in Stockinette stitch. ON EACH SIDE, increase 1 st. every 8th row 8x, every 6th row 8x for both sizes. After Row 126 (136), bind off.

FRONT: I

Cast on 88 (94) sts. with color 1 and work the 14 rows of Ribbing. Continue with the INTARSIA PATTERN as shown on the Chart. After Row 56, work the top of the houses using Short rows. Each section must be worked separately. When this is completed, continue with color 1. After Row 100 (104), ON EACH SIDE increase 1 st. every 15th row 4x for both sizes. After Row 137 (141), bind off the center 8 sts., put the needles on the left into holding position and complete the right side first. *ON NECK SIDE, bind off 3 sts. 2x, 2 sts. 3x, 1 st. 5x for both sizes. After Row 164 (168), SHAPE SHOULDER same as the back. Bring the needles on the left into working position, knit 1 row to the left side, turn the Row Counter back to 137 (141) and complete the left half. Follow the instructions from *.

KK 870

CHILD'S PULLOVER
WITH EMBROIDERY

SIZES: 4 (6)
YARN: Euro Sport
GRAMS:
color 1 100 100
color 2 50 50
color 3 50 50

plus a few yards of other colors
not included in Kit.

TENSION: 7 to 9

GAUGE: 13 sts. 18 1/2 rows = 5 cm (2")

Stockinette stitch using Short Rows
on the front section for knitting the
2 colors. K1, P1 Ribbing for the
bands.

FINISHING: See General Instructions.
Embroider the flowers and Leaves as
shown (see picture).

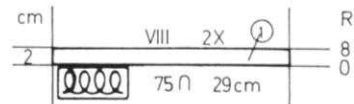

ARMBANDS: VIII Make 2.

Cast on 75 sts. with color 1
and work 8 rows Ribbing.
Bind off or remove onto waste
yarn.

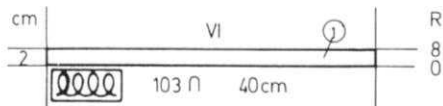

NECKBAND: VI

Cast on 103 sts. with color 1
and work 8 rows Ribbing.
Bind off or remove onto waste
yarn.

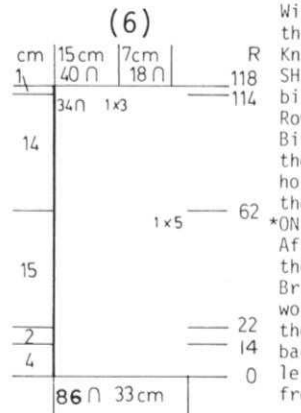
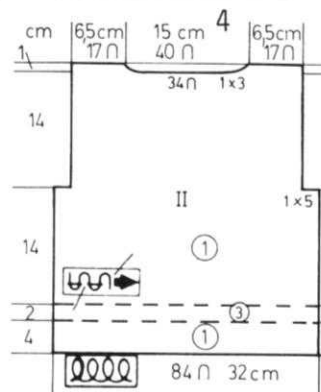
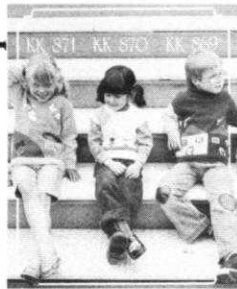
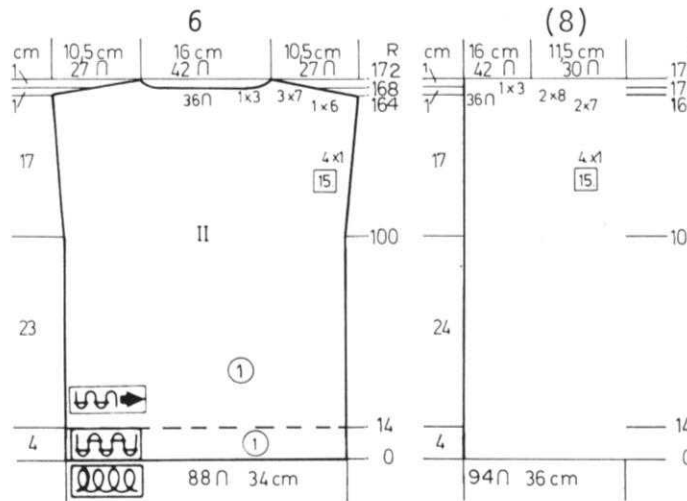
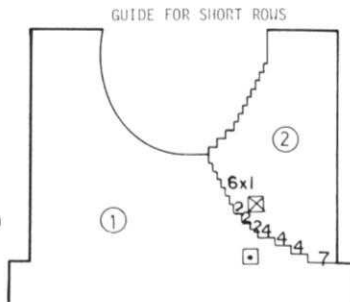
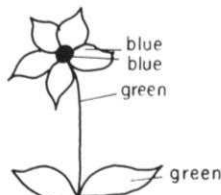
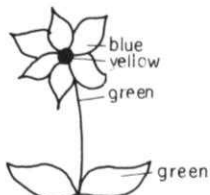
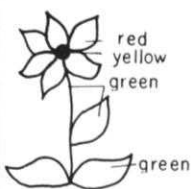

BACK: II

Cast on 88 (94) sts. with color 1
and work 14 rows K1, P1 Ribbing.
Continue in Stockinette stitch.
Knit to Row 100 (104).
ON EACH SIDE increase 1 st. every
15th row 4x for both sizes.
After Row 164 (168) SHAPE SHOULDER
(watch for neck shaping).
ON EACH SIDE, bind off
6 sts. 1x, 7 sts. 3x,
(7 sts. 2x, 8 sts. 2x),
AT THE SAME TIME, after Row
168 (172) bind off the center
36 sts. for neck, put the
needles on the left into holding
position and complete the right
side first.
*ON NECK SIDE, bind off
3 sts. 1x, for both sizes.
Bring the needles on the left into
working position, knit 1 row to the
left side, turn the Row Counter
back to 168 (172) and complete
the left half. Follow the in-
structions from * and don't forget
to complete the shoulder shaping.

BACK: II

Cast on 84 (86) sts. with color
1 and work 14 rows Ribbing.
Continue in Stockinette stitch.
With color 3, knit to Row 22
then continue with color 1.
Knit to Row 58 (62).

SHAPE ARMHOLE: ON EACH SIDE
bind off 5 sts. then knit to
Row 110 (114).

Bind off the center 34 sts., put
the needles on the left into
holding position and complete
the right side first.

*ON NECK SIDE, bind off 3 sts. 1x.
After Row 114 (118), bind off
the remaining sts.

Bring the needles on the left into
working position, knit 1 row to
the left side, turn the Row Counter
back to 110 (114) and complete the
left half. Follow the instructions
from *.

FRONT: I

Work the front the same as the
back to Row 58 (62).

ON ARM SIDE, bind off 5 sts.,
knit across to the left and bind
off 5 sts. (Armhole).

NOW WORK SHORT ROWS:

ON OPPOSITE SIDE OF SLIDE (right)
put into holding position 7 sts.
Follow the Chart for working the
short rows. Be sure to wrap the
inside needle in holding position
each time in order to prevent a
hole.

After Row 84 (88), bind off
the center 12 sts. (see Chart)
then on neck side, bind off 2 sts.
3x, 1 st. 8x.

After Row 114, (118) bind off
the remaining sts.

Move the Slide to the right side.
With color 2, work SHORT ROWS.

Counter at 58 (62).
Bring back into working position
7 sts. then following the Chart
bring back the needles as shown
on every 2nd row.

After Row 84 (88), ON NECK SIDE,
bind off 2 sts. 3x, 1 st. 8x.
After Row 114 (118), bind off
the remaining sts.

KK 871

CHILD'S PULLOVER

SIZES: 5/6 (7/8)
YARN: Euro Sport

GRAMS:
color 1 150 200
color 2 50 50
color 3 50 50
color 4 100 100
TENSION: 7 to 9
GAUGE: 13 sts. 18 rows = 5 cm (2")

Stockinette stitch with Short Rows and Intarsia Designs.
Bands are K1, P1 Ribbing.

FINISHING: See General Instructions.

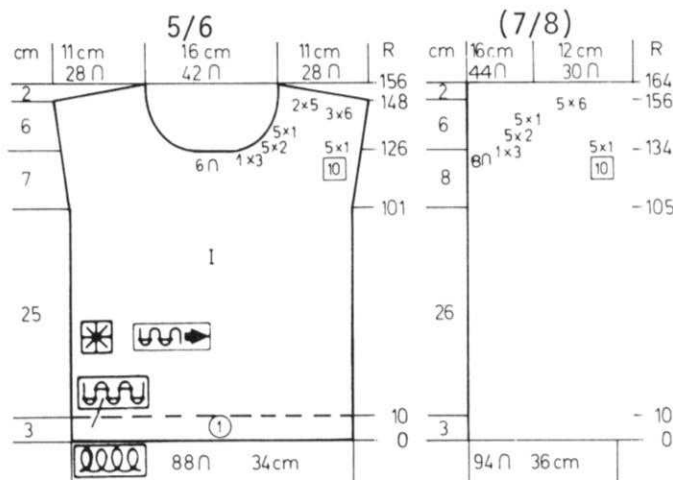

FRONT: I

The front is worked with SHORT ROWS, plus Intarsia for the House and Clouds and embroidery for the flower and leaves - See Picture. You could also work the House and the Clouds using duplicate stitch placing them as shown on picture.

Cast on 88 (94) sts. with color 1 and work 10 rows Ribbing. Continue with Stockinette stitch and SHORT ROWS.

Put 38 (41) sts. on the left into holding position. Knit over the rest of 50 (53) sts. with color 2 and work 10 rows Ribbing. Continue with Stockinette stitch and SHORT ROWS. Put 38 (41) sts. on the left into holding position. Knit over the rest of 50 (53) sts. with color 2 and work over the 38 sts. on the left with color 3. AT THE SAME TIME approximately at Row 30, begin the house if you are working it in Intarsia, following the Chart but begin the SHORT ROWS immediately after Row 10.

Bring back into working position, 1 st. every 4th row 4x, 1 st. every 2nd row 6x, then 2 sts. every 2nd row 8x.

After Row 54, knit 4 rows even. With color 3, bring into holding position 1 st. 3x, then 2 sts. 8x. At Row 100, all sts. in holding position. Put the Row Counter to 56 and continue with color 4 and begin again with 2 sts. (see Chart). After Row 66, knit even. After Row 101 (105) work the clouds as shown on the Chart and AT THE SAME TIME, ON EACH SIDE, increase 1 st. every 10th row 5x.

After Row 126 (134) bind off the center 6 (8) sts., put the needles on the left into holding position and complete the right side first. *ON NECK SIDE, bind off 3 sts. 1x, 2 sts. 5x, 1 st. 5x. After Row 148 (156), SHAPE SHOULDER same as the back.

Bring the needles on the left into working position, knit 1 row to the left side, turn the Row Counter back to 126 (134) and complete the left half. Follow the instructions from *.

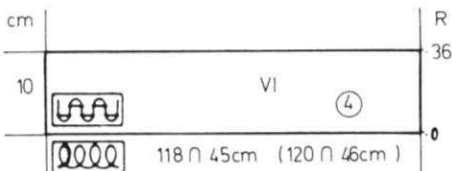

COLLAR: VI

Cast on 118 (120) sts. with color 4 and work 36 rows Ribbing. Bind off or remove onto waste yarn.

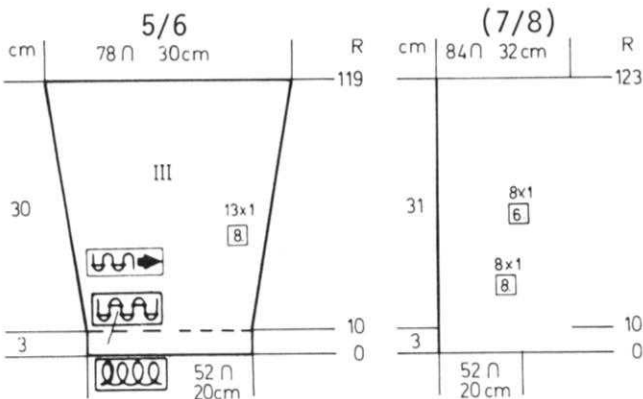

SLEEVES: III

Cast on 52 sts. for both sizes with color 1. Work 10 rows Ribbing. Continue in Stockinette stitch. ON EACH SIDE, increase 1 st. every 8th row 13x. (every 8th row 8x, every 6th row 8x). After Row 119 (123), bind off.

BACK: II

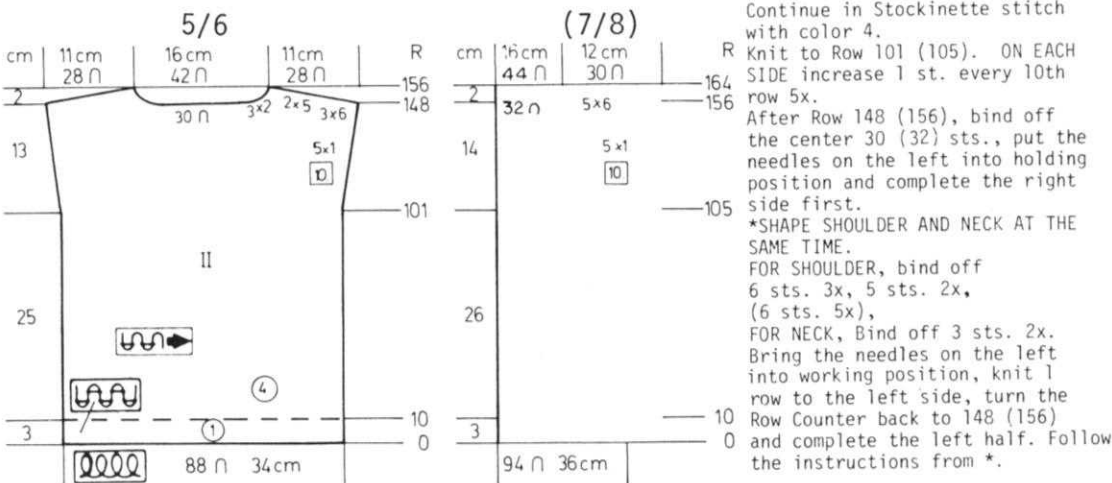

Cast on 88 (94) sts. with color 1 and work 10 Rows Ribbing. Continue in Stockinette stitch with color 4.

Knit to Row 101 (105). ON EACH SIDE increase 1 st. every 10th row 5x.

After Row 148 (156), bind off the center 30 (32) sts., put the needles on the left into holding position and complete the right side first.

*SHAPE SHOULDER AND NECK AT THE SAME TIME.

FOR SHOULDER, bind off 6 sts. 3x, 5 sts. 2x, (6 sts. 5x),

FOR NECK, Bind off 3 sts. 2x. Bring the needles on the left into working position, knit 1 row to the left side, turn the Row Counter back to 148 (156) and complete the left half. Follow the instructions from *.

KK 873



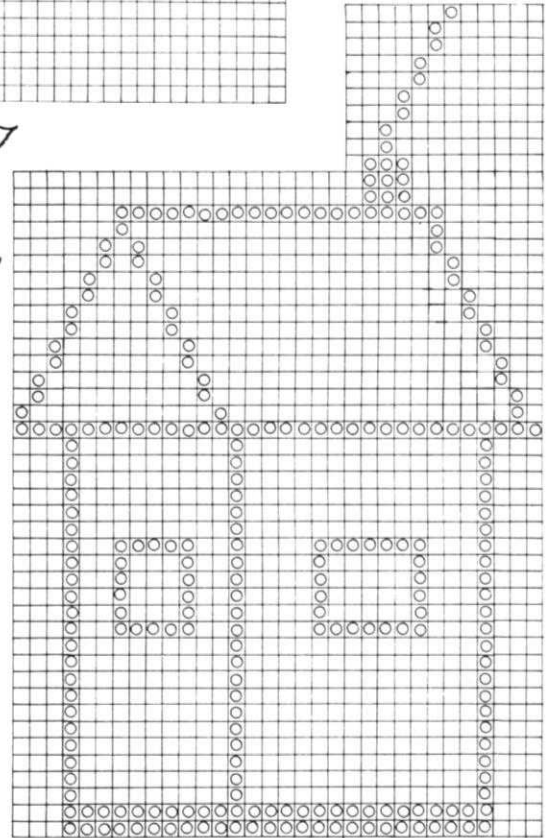
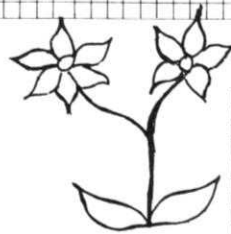
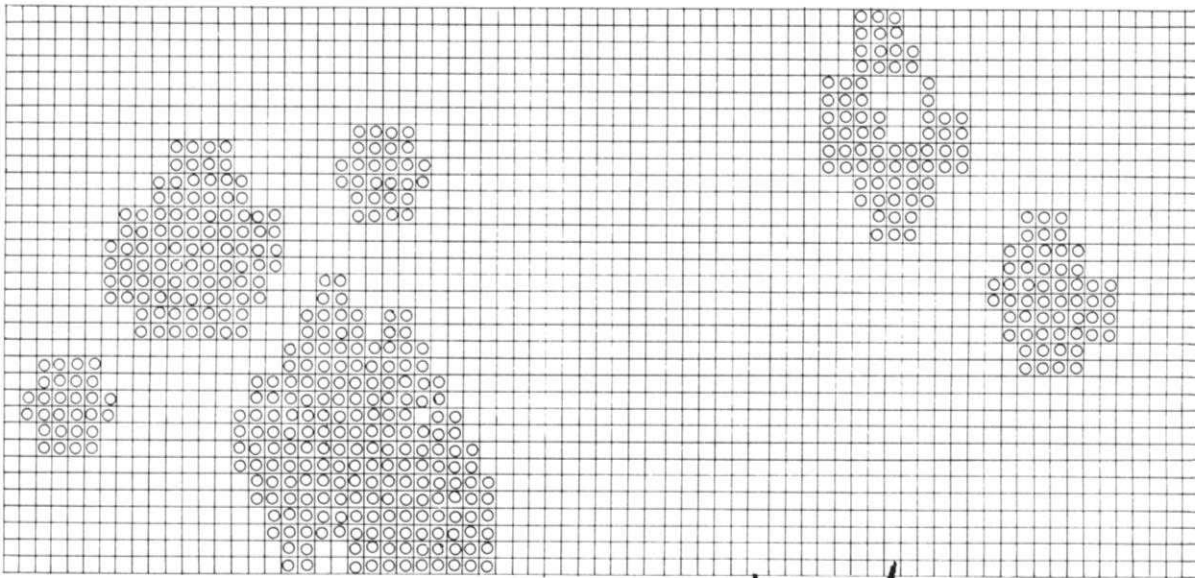

TODDLER'S SUIT

SIZES: 6 to 12 Mo. 12 to 24 Mo.
 YARN: Amore
 GRAMS:
 color 1 100 150
 color 2 100 150
 TENSION: 6 to 8
 GAUGE: 13 sts. 15 1/2 rows = 5 cm (2")

A Norwegian Design for the Pullover with sleeves in stripes. Bands are K2, P2, Ribbing. The Pants are K2, P2 with stripes of 4 rows color 1, 4 rows color 2.

FINISHING: See General Instructions.

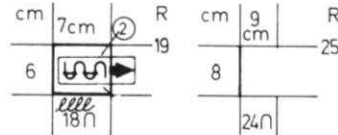

CROTCH GUSSET

Cast on 18 (24) sts. with color 2 and work Stockinette stitch to Row 19 (25) then bind off.

6 to 12 Months (14 to 24 Months)

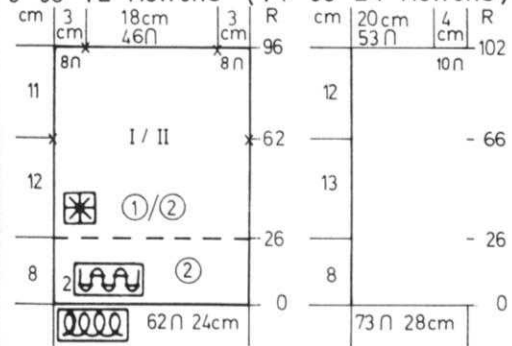

PULLOVER BACK AND FRONT: 2 sections the same.

Cast on 62 (73) sts. with color 2 and work 26 rows Ribbing. Continue in Diagonal Pattern. After Row 62 (66), mark each side for setting in sleeves. After Row 96, bind off the 8 (10) sts. for shoulders, then bind off the remaining 46 (53) neck sts.

6 to 12 Months (14 to 24 Months)

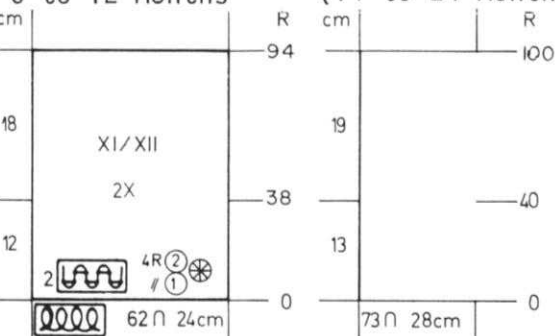

PANTS: XL/XIII, Make 2 sections the same.

Cast on 62 (73) sts. with color 1 and work in Ribbing with REPEATED Color Stripes of 4 rows color 1, 4 rows color 2. After Row 38 (40), mark each side for setting in crotch gusset. After Row 94 (100), bind off.

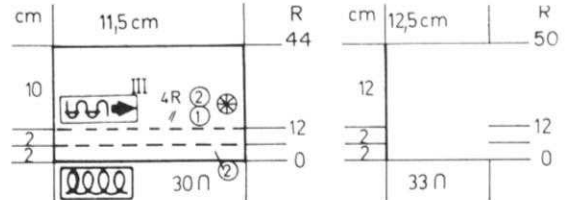

PULLOVER SLEEVES: III

Cast on 30 (33) sts. with color 2 and work Stockinette stitch to Row 12, then hang the hem. Continue in Stockinette stitch with 4 rows color 1, 4 rows color 2. After Row 44 (50), bind off

KK 872

CHILD'S 2-PIECE SUIT

SIZES: 6 to 12 mo. (14 to 24 mo.)
 YARN: Crocus
 GRAMS:
 color 1 100 150
 color 2 100 150
 color 3 100 150
 TENSION: 6 to 8
 GAUGE: 11 sts. 16 rows = 5 cm (2")

Stockinette stitch with color stripes as shown on the Chart. K2, P2 for Bands.

FINISHING: See General Instructions. Sew zipper in pants.

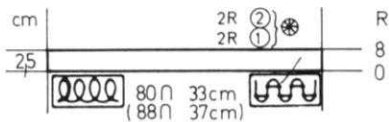

PULLOVER NECKBAND:

Cast on 80 (88) sts. and work 8 rows ribbing with color stripes as shown on the Chart.

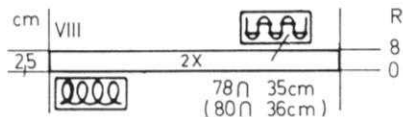
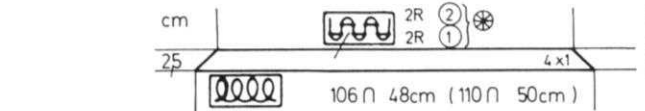
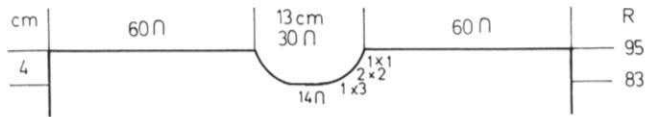

COVER-ALL ARMBANDS:

Sew shoulder seams first, then pick up 78 (80) sts. around armhole and work 8 rows Ribbing with color stripes same as the Neckband. Bind off.

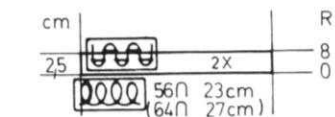

PULLOVER SLEEVE BANDS:

Sew shoulders first, then pick up 56 (64) sts. and work 8 rows Ribbing with color stripes as shown on the Chart. Bind off.

6 to 12 Months

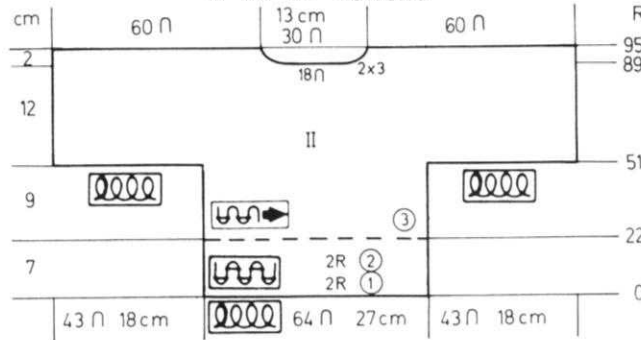

PULLOVER FRONT: I

work the front the same as the back to Row 83 (92). Bind off the center 14 (16) sts. put the needles on the left into holding position and complete the right side first.
 *ON NECK SIDE, bind off 3 sts. 1x, 2 sts. 2x, 1 st. 1x. (4 sts. 1x, 2 sts. 2x, 1 st. 2x). After Row 95 (104), bind off the remaining sts.
 Bring the needles on the left into working position, knit 1 row to the left side, turn the Row Counter back to 83 (92) and complete the left half. Follow the instructions from *.



(14 to 24 Months)

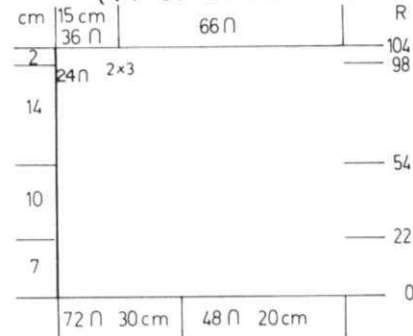

PULLOVER BACK: II

Cast on 64 (72) sts. with color 1 and work 22 rows Ribbing with color stripes as shown on the Chart. Continue in Stockinette stitch with color 3.
 After Row 51 (54) ON EACH SIDE, cast on 43 (48) sts. knit to Row 89 (98).
 SHAPE NECK: Bind off the center 18 (24) sts., put the needles on the left into holding position and complete the right side first.
 *ON NECK SIDE, bind off 3 sts. 2x for both sides. After Row 95 (104), bind off the remaining sts.
 Bring the needles on the left into working position, knit 1 row to the left side, turn the Row Counter back to 89 (98) and complete the left half. Follow the instructions from *.

COVER-ALL NECKBAND:

Cast on 106 (110) sts. with color 1 and work in Ribbing with REPEATED STRIPES of 2 rows color 1, 2 rows color 2 AND AT THE SAME TIME, ON EACH SIDE, decrease 1 st. every 2nd row 4x. After Row 8, remove onto waste yarn or bind off.

COVER-ALL FRONT AND BACK: XI/XII Reverse for 2nd section.

Cast on 64 (72) sts. with color 1 and work in Ribbing with color stripes as shown on the Chart. Begin with 4 rows color 1 then *2 rows color 2, 2 rows color 1 and REPEAT from *.
 After Row 35, continue in Stockinette stitch with REPEATED color stripes of 6 rows color 1, 2 rows color 2. After Row 107 (110), continue in Ribbing to Row 129 (132) then continue in Stockinette with stripes to Row 148 (154). Put half the sts. on the left into holding position and complete the right side first.
 ON ARMHOLE SIDE, bind off 3 sts. 1x, 2 sts. 2x (3x), 1 st. 3x.
 After Row 186 (196), Bind off 6 sts. 1x, 4 sts. 1x, 3 sts. 1x. (6 sts. 1x, 5 sts. 1x, 4 sts. 1x). After Row 192 (202), bind off the remaining 9 sts.
 Bring the needles on the left into working position, knit 1 row to the left side, turn the Row Counter back to 148 (154) and complete the left half.
 ON ARM SIDE, make the bind offs the same as you did before and ON NECK SIDE, decrease 1 st. every 3rd row 13x (15x). After Row 192 (202) bind off the remaining 9 sts.

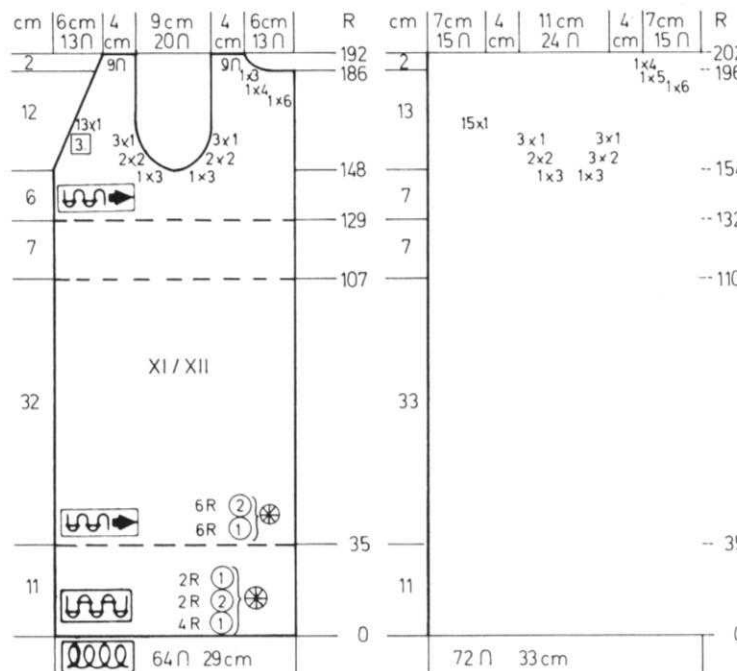

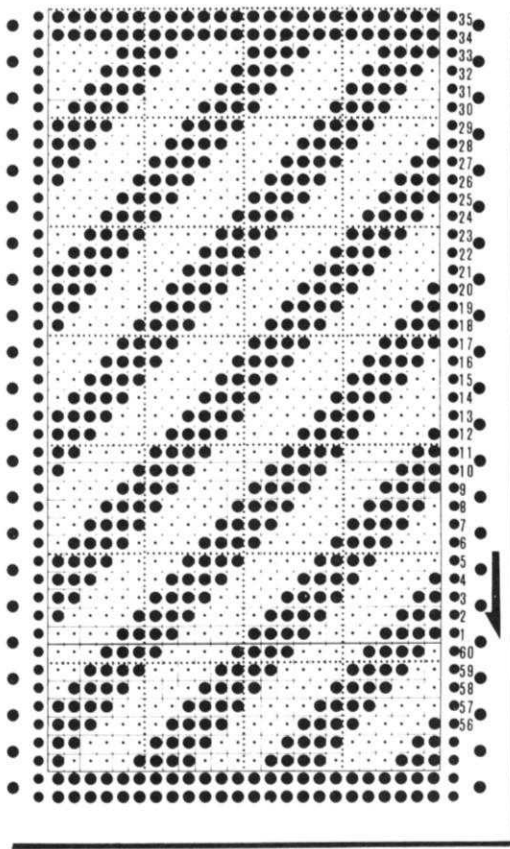

DK 875

WOMAN'S PULLOVER

SIZES: 12/14 (loose fitting)
 YARN: Euro Sport
 GRAMS:
 color 1 100
 color 2 150
 color 3 100
 color 4 100
 TENSION 8 to 10
 GAUGE: 8 1/2 sts. 12 rows = 5 cm (2")



The Pullover is knitted in strips OVER EVERY OTHER NEEDLE. If you own a JUMBO machine, you can easily knit it on every needle. The bands are K1, P1 Ribbing. JUMBO machine owners, latch up the stitches for Ribbing.

FINISHING: Sew strips together or put them together on a BELLINKY. Sew the bands in place.



ARMBANDS: Make 2.

Cast on 74 sts. over every other needle and work 8 rows K1, P1 Ribbing. Remove onto contrast waste yarn.

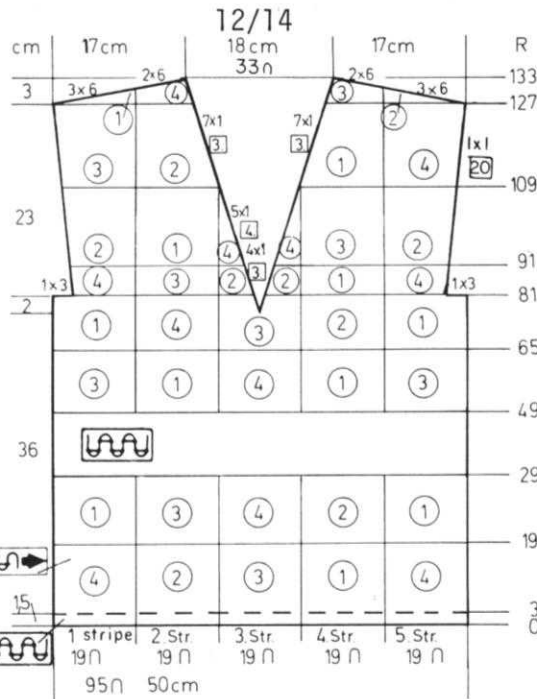

FRONT: Mark the needle bed and work the strips separately (EON) to the Ribbing at waist. Transfer the sts. to the ribber and work over all needles, then work the strips separately again. Begin with the first 19 sts. on the LEFT side and after Row 29 put these sts. into holding position. Work the next strip, etc. etc. following the changes in color as shown on the Chart. After Row 29, transfer every other stitch to the Ribber and work the Ribbing to Row 49. Transfer the ribber sts. to main machine and work each strip separately again. After Row 81, bind off 3 sts. for armhole and when working the center strip, transfer the center stitch to adjacent needle and work each side of the center strip separately. ON NECK SIDE, decrease 1 st. every 3rd row 4x, every 4th row 5x, every 3rd row 7x. ON ARM SIDE, for the first and last strip, increase 1 st. every 10th row 1x. After Row 127, SHAPE SHOULDER for each strip as shown on the Chart.

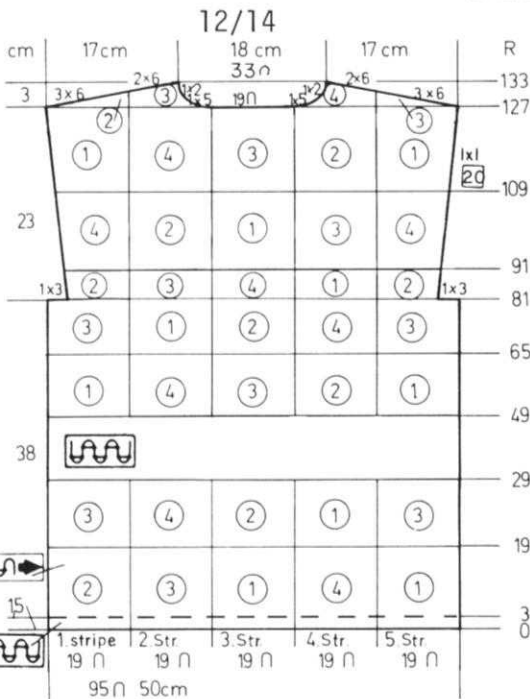

BACK:

Work the back the same as the front except for the NECK SHAPING. Follow the Chart for the bind offs as given. The center neck sts. are bound off after Row 127. Shaping for shoulder is the same as for the front.

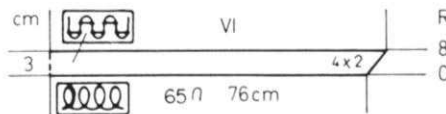

NECKBAND: Make 1, reverse 1.

Cast on 65 sts. EVERY OTHER NEEDLE and work K1, P1 Ribbing. ON THE RIGHT (left for 2nd piece), increase 2 sts. every 2nd row 4x. After Row 8, remove the sts. onto contrast waste yarn.



HP 874

MAN'S PULLOVER

SIZE: 40/42
 YARN: Crocus Crepe
 GRAMS: color 1 700, color 2 250
 TENSION: 10 Rib. 8
 GAUGE:

Stock: 12 sts. 16 rows = 5 cm (2")
 Pat: 10 1/2 sts. 33 rows = 5 cm (2")

A Tuck Stitch Pattern worn on the purl side. 840, 830, 820, machine owners use Punch Card No. 1 and push in BOTH Tuck Buttons. Back, Sleeves and front band, neckband and pocket bands are stockinette stitch - all on the purl side. Waistband and sleeve bands are K1, P1 Ribbing.

FINISHING: See General Instructions.

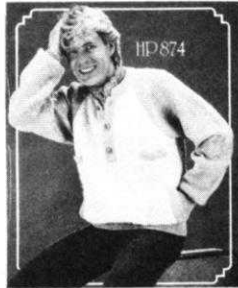
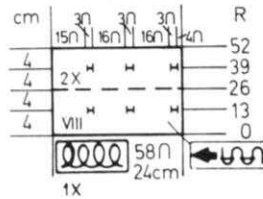
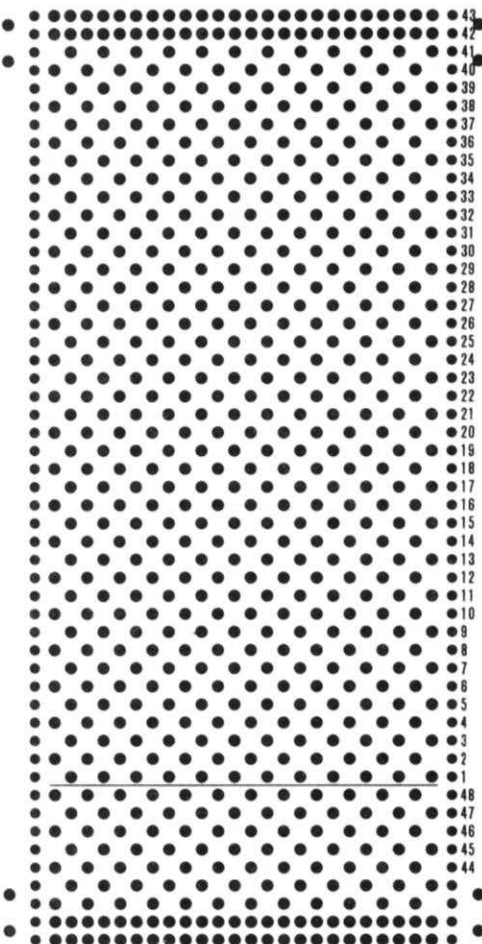
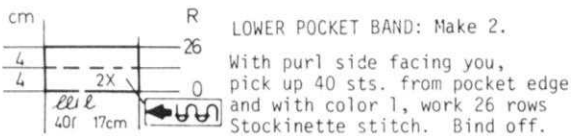
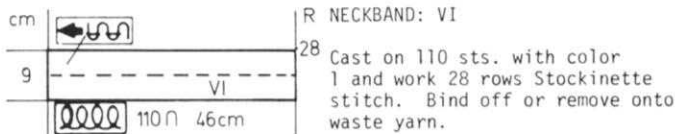

FRONT BANDS: VIII Make 2.
 Make 1 without Buttonholes

Cast on 58 sts. with color 1 and work Stockinette stitch. After Row 13, make Buttonholes. Counting from the LEFT, leave 15 sts. and make Buttonhole over the next 3 sts., leave 16, buttonhole over next 3, leave 16, buttonhole over next 3. After Row 39, REPEAT the Buttonholes over same needles as before. After Row 52, bind off or remove onto waste yarn.

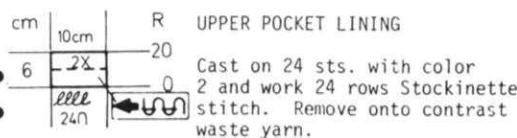
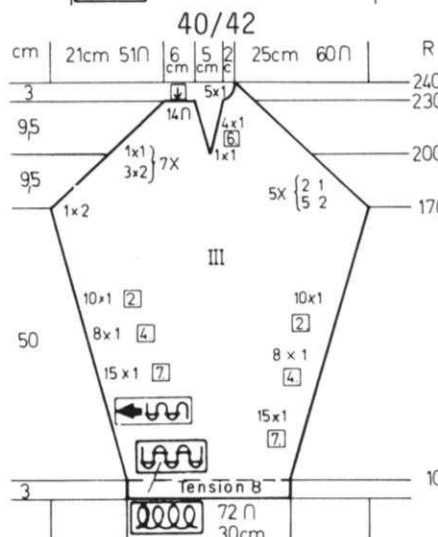
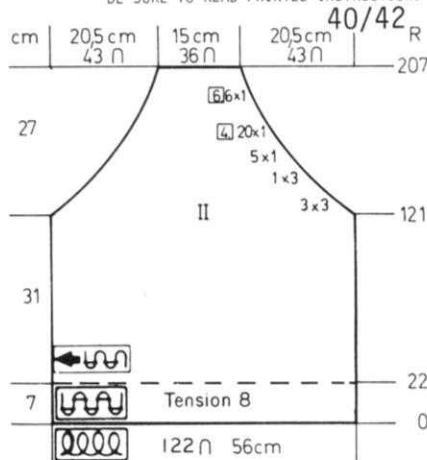
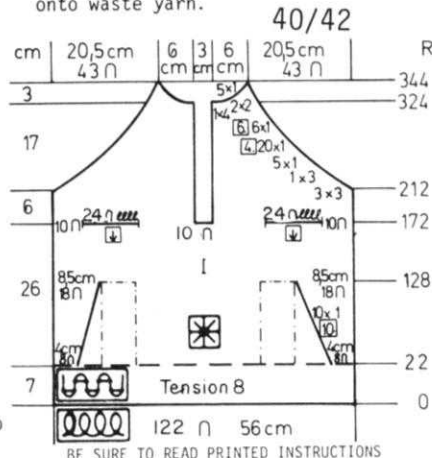

FRONT: I Make upper Pocket Linings first.

Cast on 122 sts. with color 1 and work 22 rows Ribbing with Tension 8. Continue in Pattern with color 2 and tension 10. FOR POCKET, put 8 sts. ON EACH SIDE into holding position. ON EACH SIDE, decrease 1 st. every 10th row 10x.

After Row 128, remove these sts. onto contrast waste yarn. Bring 8 sts. on the right into working position, then cast on 20 sts. directly to the left of the 8 sts. Counter at 22. Work in Pattern to Row 128. Bind off left 20 sts. REPEAT for the LEFT SIDE, reversing the sides. When pockets are completed, hang the sts. held on waste yarn back onto the machine, Counter at 128 and continue over all sts. After Row 172, bind off the center 10 sts. and AT THE SAME TIME, ON EACH SIDE, leave 10 sts. then bind off the next 24 sts. Hang the pocket linings onto these sts. and work 1 side at a time. After Row 212, work the bind off for the Raglan as shown on the Chart and after Row 324, SHAPE NECK as shown on the Chart. Bring the needles on the left into working position and complete the left side, following the instructions from Row 172 after the neck and pocket bind offs.

BACK: II

Cast on 122 sts. with color 2 and work 22 rows Ribbing with tension 8. Continue in Stockinette stitch with color 1. Knit to Row 121. SHAPE RAGLAN: ON EACH SIDE, bind off 3 sts. 3x, 3 sts. 1x, 1 st. 5x, 1 st. every 4th row 20x, 1 st. every 6th row 6x. After Row 207, bind off the remaining sts.

SLEEVES: III

Cast on 72 sts. with color 2 and work 10 rows Ribbing. Continue in Stockinette stitch. ON EACH SIDE, increase 1 st. every 7th row 15x, every 4th row 8x, every 2nd row 10x. After Row 170, SHAPE RAGLAN. Please follow the different bind offs on each side as shown on the Chart and after Row 200, divide in the center and work 1 side at a time. FOR DART, decrease 1 st. 1x, then every 6th row, decrease 1 st. 4x. After Row 230, on inner edge, decrease 1 st. 5x. Bring the needles on the left into working position, knit 1 row to the left side, turn the Row Counter back to 200 and complete the left half. ON INNER EDGE, decrease 1 st. every 6th row 4x, and after Row 230, bind off the remaining sts.

UPPER POCKET BAND: Make 2.

With purl side facing you, pick up 24 sts. on pocket edge and with color 1, work 20 Rows Stockinette stitch. Bind off.

DK 876

WOMAN'S PULLOVER

SIZES: 8/10 (12/14)
 YARN: Euro Sport
 GRAMS: 500 550
 TENSION: 7 to 9
 GAUGE: 9 sts. 24 rows = 5 cm

OVER EVERY OTHER NEEDLE.
 Ribbed Band: 13 sts. 14 rows = 5 cm (2")

Fisherman's Rib OVER EVERY OTHER NEEDLE. The bands are K1, P1 Ribbing. Every 4th needle on the main machine and every 4th needle on the Ribber is used throughout. Set the machine for plain ribbing then set it for FISHERMAN'S RIB.

FINISHING: Sew shoulders then set in sleeve to marked rows. Sew side and sleeve seams. Sew neckband in place.

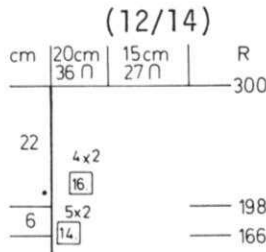
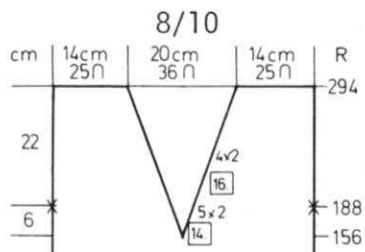

FRONT: I

The front is worked the same as the back to Row 156 (166). Divide in the center, put the needles on the left into holding position and complete the right first.

*ON NECK SIDE, decrease 2 sts. every 14th row 5x, and every 16th row 4x for both sizes AND AT THE SAME TIME, mark Row 188 (198) for setting in sleeves. After Row 294 (300), bind off the remaining 25 (27) sts. Bring the needles on the left into working position, knit 1 row to the left side, turn the Row Counter back to 156 (166) and complete the left half. Follow the instructions from *.

BACK: II

Cast on 86 (90) sts. (every 4th on machine and every 4th on Ribber). Work 22 rows K1, P1 Ribbing then continue in FISHERMAN'S RIB. After Row 188 (198) mark each side for setting in sleeves then knit to Row 294 (300). Bind off 25 (27) sts. ON EACH SIDE for shoulder, then bind off the remaining 36 neck sts.

SLEEVES: III

Cast on 44 (48) sts. same way as front and back and work 22 rows K1, P1 Ribbing. Continue in FISHERMAN'S RIB. ON EACH SIDE, increase 1 st. every 8th row 10x, every 14th row 6x for both sizes. After Row 190 (194), bind off the remaining sts.

NECKBAND: VI Make 1, reverse 1.

Cast on 95 sts. same way as you did for other sections and work in K1, P1 Ribbing. ON THE RIGHT (left for 2nd section), increase 1 st. every 2nd row 5x. Bind off or remove onto contrast waste yarn.

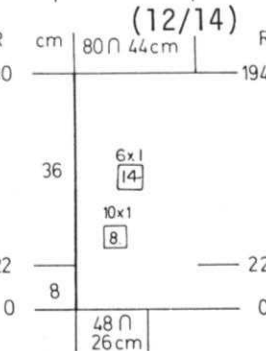
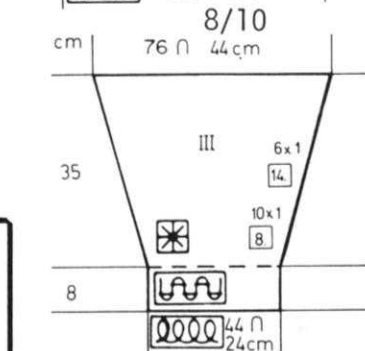
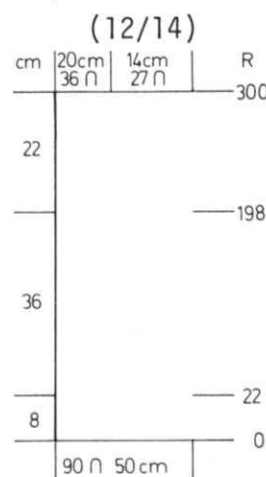
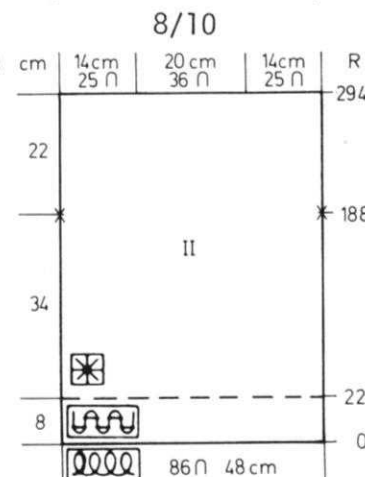

KK 877

TEENAGE DRESS

SIZES: 12 (14)
 YARN: Amore
 GRAMS:
 color 1 450 500
 color 2 50 50
 color 3 50 50
 color 4 50 50
 color 5 50 50
 TENSION: 5 to 7
 GAUGE: 13 sts. 22 rows = 5 cm (2")

Stockinette stitch with color stripes.

FINISHING: See General Instructions.

NOTE: Begin with color 1 and work 54 rows, then 2 rows color 2. Each time you work a stripe, change the color (see Picture).

Continue with
 34 rows color 1 + 2 rows Stripe (4x)
 14 rows color 1 + 2 rows Stripe (4x)
 8 rows color 1 + 2 rows Stripe (4x)
 10 rows color 1 + 2 rows Stripe (6x)
 22 rows color 1 + 2 rows Stripe (4x)
 Continue with color 1 only.

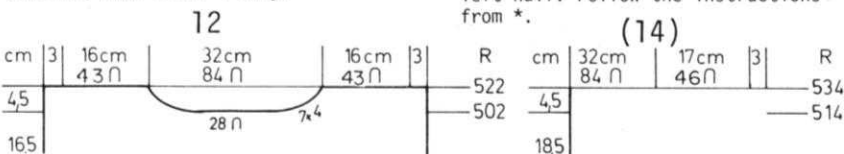

FRONT: I

Work the front the same as the back to Row 502 (514). Bind off the center 28 sts., put the needles on the left into holding position and complete the right side first. *ON NECK SIDE, bind off 4 sts. 7x for both sizes. After Row 522 (534), bind off the remaining 43 (46) sts. Bring the needles on the left into working position, knit 1 row to the left side (watch stripe), turn the Row Counter back to 502 (514) and complete the left half. Follow the instructions from *.

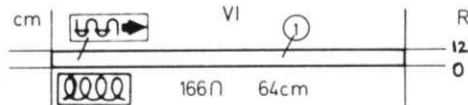

NECKFACING: VI

Sew up one shoulder seam, then pick up 166 sts. around neckline and with color 1, work 12 row Stockinette stitch. Bind off.



KNITTING presents ..

COMPUKNIT



- ★ The COMPUKNIT KH 910 operates with pictures (not punch cards). An assortment of illustrated Jacquard, Fairisle, Tuck Stitch, Weaving and Lace is supplied, plus some blank sheets for your own designs.
- ★ The COMPUKNIT reproduces pictures in your knitting, in colors of your choice... Pictures up to 120 stitches wide. Pattern sheets are 60 stitches wide... You can double them, stretch them, etc., all electronically, just by moving buttons on the illustrated control panel.
- ★ The COMPUKNIT has a true electronic computer built into it and you program it to knit a picture you desire. Small guide lights instruct you step-by-step and a warning light makes a setting error.
- ★ Program the COMPUKNIT to isolate a design. Program it to start a design on the row of your choice and to end on the row of your choice. The COMPUTER MEMORY BANK retains your instructions and transmits them to the knitter as you push the carriage back and forth.

KH910

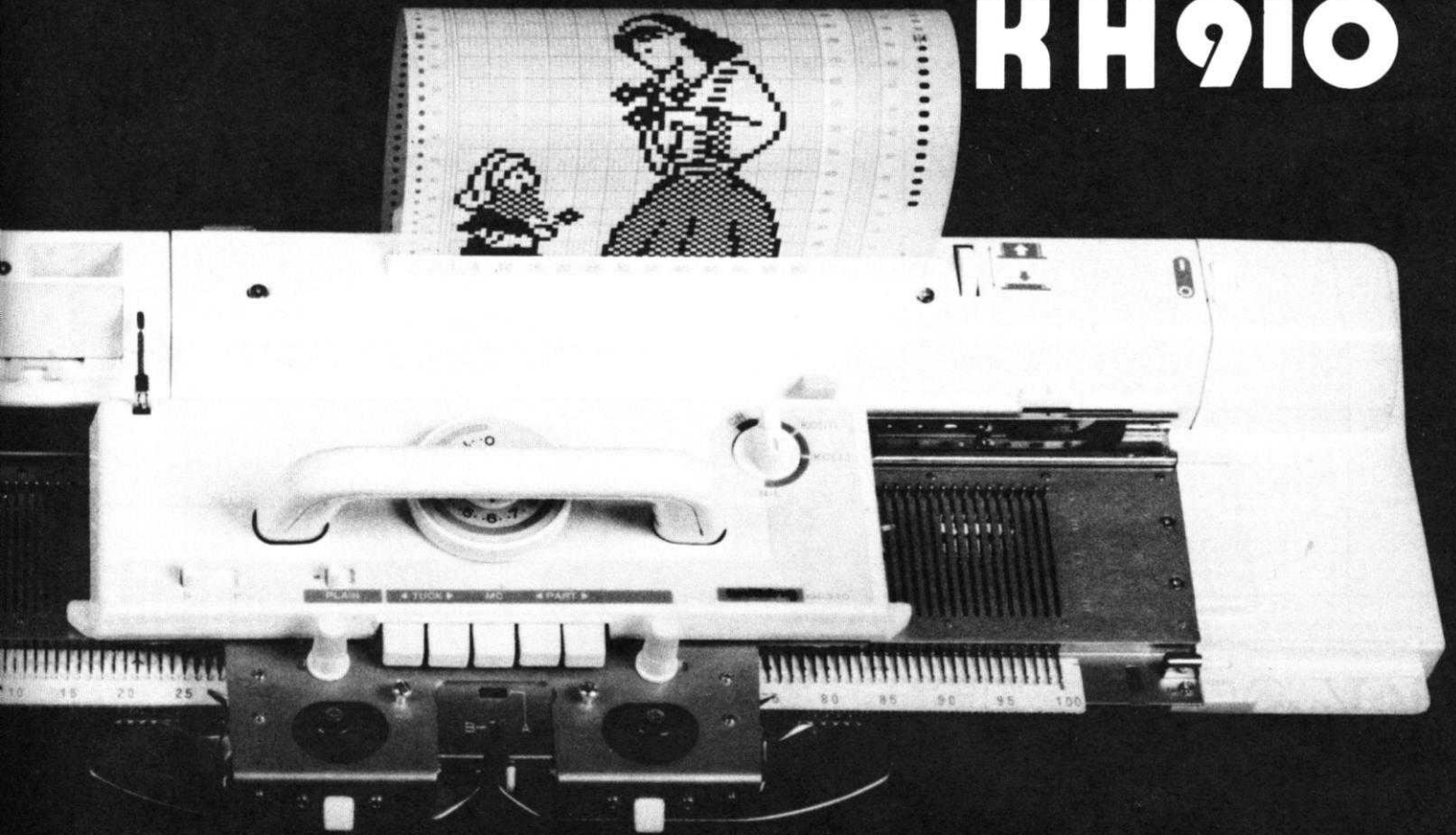

★ The COMPUKNIT 910 comes with two large, marvelous, completely detailed Instruction Manuals... #1 Manual explains with pictures and text, the entire functions of the machine plus how to knit and shape garments... #2 Manual shows you with colored pictures, the exact programming of every card supplied.

ted sheets for
draw or trace

s can be knitted
reverse them,
panel.

pattern stitch
flashes if you

our choice. Pro-
tions and trans-

INSTRUCTION MANUAL

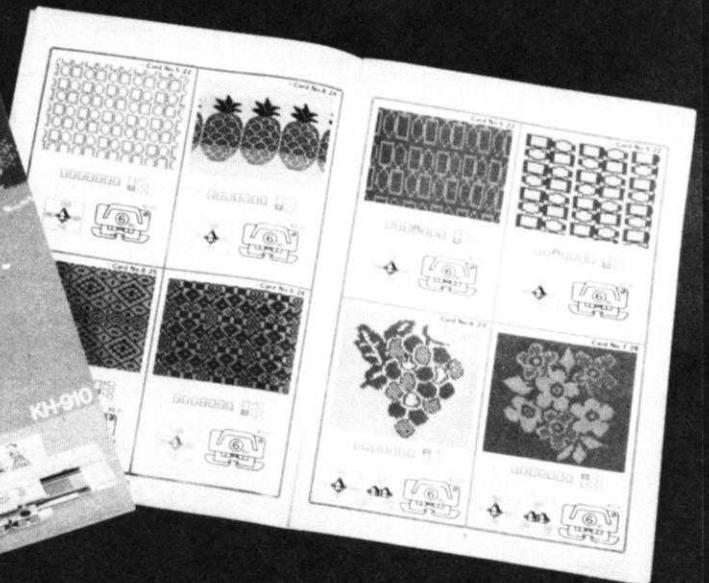

KK 877

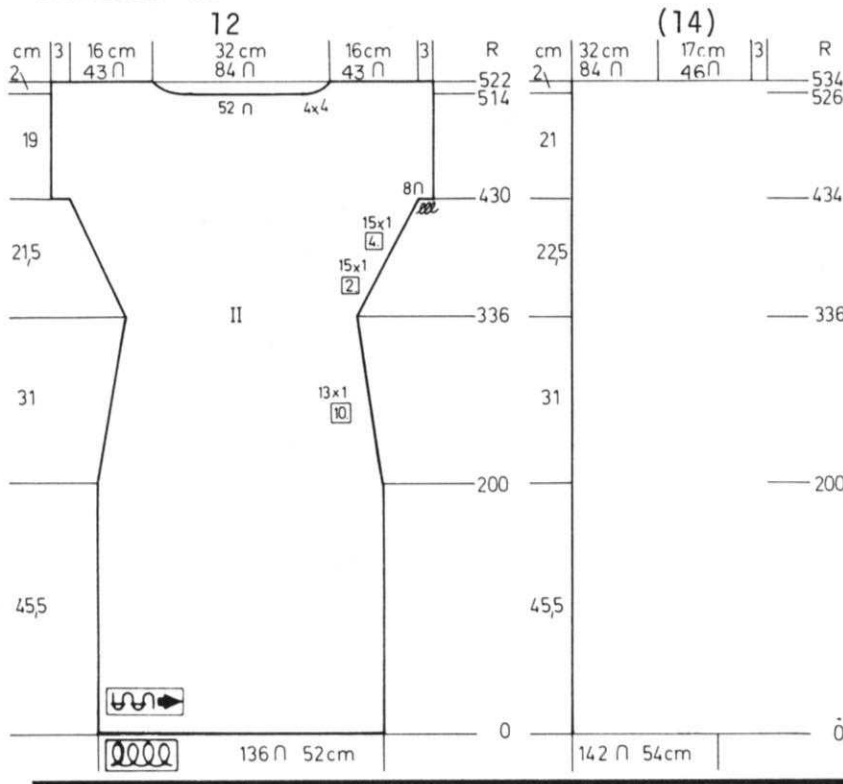

Cast on 136 (142) sts. with color 1 and work in Stripe Pattern. After Row 200, ON EACH SIDE, decrease 1 st. every 10th row 13x for both sizes. After Row 336, ON EACH SIDE, increase 1 st. every 2nd row 15x, every 4th row 15x for both sizes, then ON EACH SIDE cast on 8 sts. Knit to Row 514 (526). Bind off the center 52 sts. put the needles on the left into holding position and complete the right side first. *ON NECK SIDE, bind off 4 sts. 4x for both sizes. After Row 522 (534), bind off the remaining 43 (46) sts. Bring the needles on the left into working position, knit 1 row (watch stripes) to the left side, turn the Row Counter back to 514 (526) and complete the left half. Follow the instructions from *.

KK 878

CHILD'S JACKET

SIZES: 6 to 8
YARN: Vienna
GRAMS:
color 1 100
color 2 100
color 3 Small amt.
color 4 Small amt.
color 5 Small amt.
color 6 100
color 7 Small amt.
color 8 Small amt.
color 9 100

Small amounts of colors are not included in Kit.

TENSION: 7 to 9

GAUGE: 13 1/2 sts. 18 rows = 5 cm (2")

A Norwegian Design with stripes as shown on the Chart. Punch your own Cards and follow the changes as given.

FINISHING: See General Instructions. Sew Sequins or other decorations on front as shown on Picture.

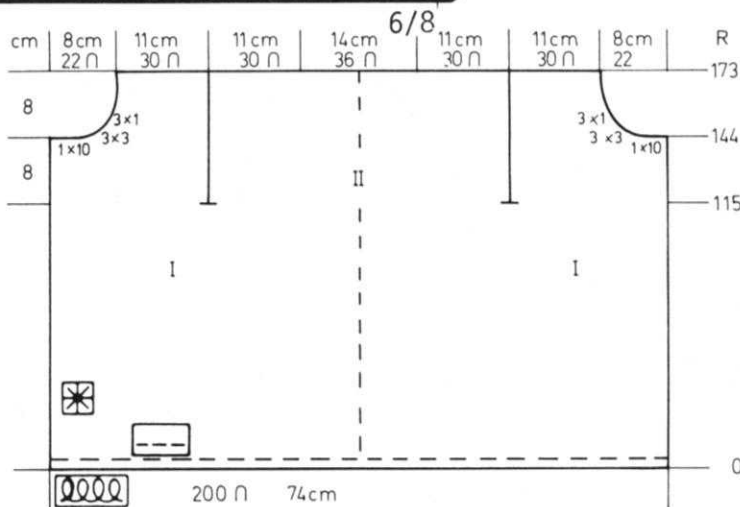

BACK & FRONT:

Cast on 200 sts. with color 1 and work 6 rows Stockinette stitch. Make Picot. Put Counter at 0 and continue with color stripes and Pattern as given. After Row 6, hang the hem. After Row 115, remove 52 sts. on the left onto waste yarn, then remove the next 96 (back) sts. onto waste yarn. Mark the needle bed so you can hang these sts. back in correct position later). Mark Pattern Row. Continue over the right 52 sts. After Row 144, SHAPE NECK: Bind off 10 sts. 1x, 3 sts. 3x. 1 st. 3x.

After Row 173, bind off the remaining sts.

Hang the next 96 (back) sts. onto machine, put Counter at 115 and work in Pattern to Row 173, then bind off.

Hang the remaining front 52 sts. back onto machine (watch Pattern) and put Row Counter to 115.

Work in Pattern to Row 144.

SHAPE NECK:

Bind off 10 sts. 1x, 3 sts. 3x, 1 st. 3x.

After Row 173, bind off the remaining sts.



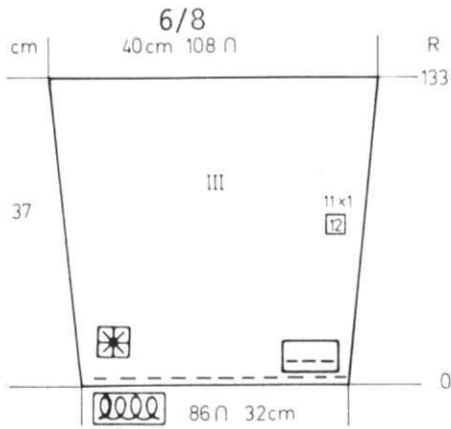

SLEEVES: III

Cast on 86 sts. with color 1 and work 6 rows Stockinette stitch. Make Picot then put Counter at 0 and continue with color stripes and Pattern as given. After Row 6, hang the hem.
ON EACH SIDE, increase 1 st. every 12th row 1lx.
After Row 133, bind off.

BAND FOR NECK & FRONT: Make 2.

Cast on 160 sts. with color 1 and work Stockinette stitch. Knit 4 rows, then 1 row tension 10, knit 4 rows. Bind off or remove onto waste yarn.

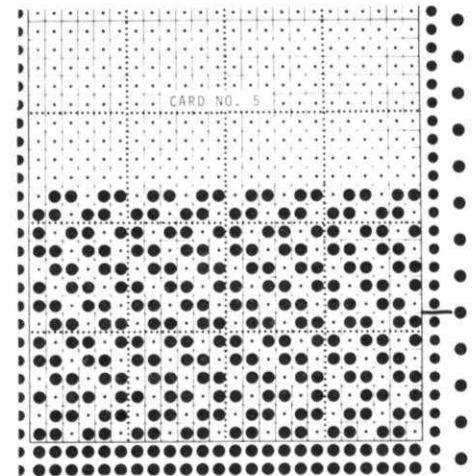
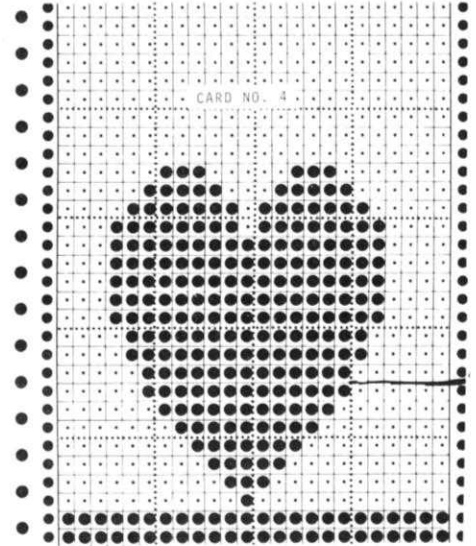
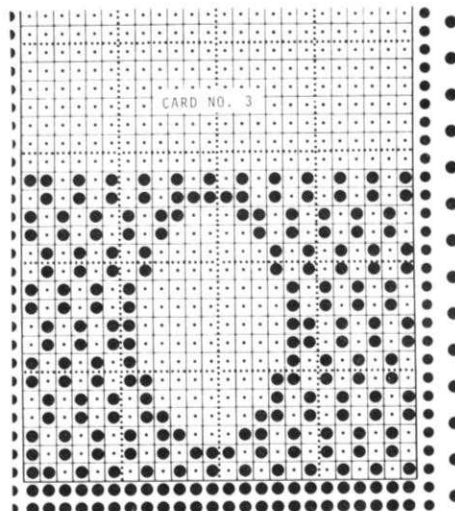
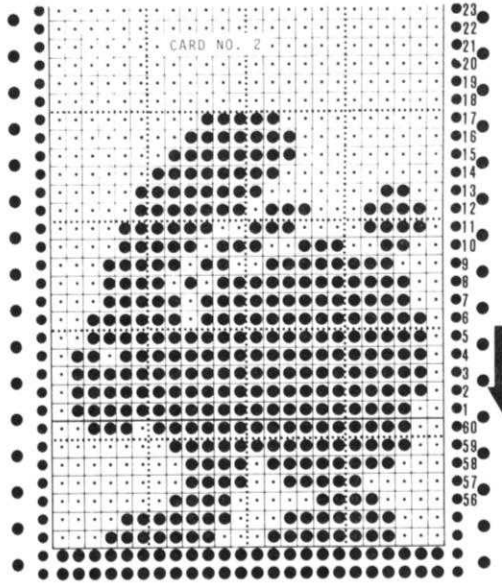
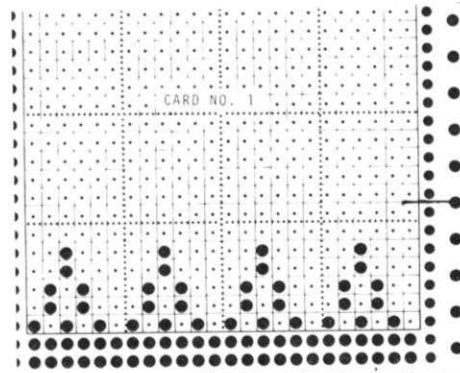

JACKET FRONT: I Make 1, reverse 1.

Cast on 44 (46) [49] sts. and work Stockinette stitch.
ON THE LEFT (right for 2nd section), on every 2nd row, cast on 3 sts. 1x, 2 sts. 2x, 1 st. 6x for all sizes.
After Row 144, SHAPE ARMHOLE:
Bind off
3 sts. 1x, 2 sts. 1x, 1 st. 3x. (Same as first size).
[3 sts. 1x, 2 sts. 2x, 1 st. 4x].
After Row 205 (205) [209]
SHAPE NECK: Bind off
1 sts. 2x, 2 sts. 1x, 1 st. 7x, 3 sts. 1x, 2 sts. 1x. 1 st. 3x for all sizes.
After Row 218 (218) [220],
SHAPE SHOULDER same as the back.

DK 879

WOMAN'S 2 PIECE SUIT

SIZES: 8/10 (12) [14]
YARN: Micaela
GRAMS:
color 1 700 750 800
color 2 100 100 100
TENSION: 6 to 8
GAUGE: 11 1/2 sts. 18 rows = 5 cm (2")

Stockinette stitch with a Cord Braid Trim.

FINISHING: See General Instructions. Work 1 row single crochet around all edges of Jacket then sew on the braided cords. Sew slit facings of skirt to the inside.

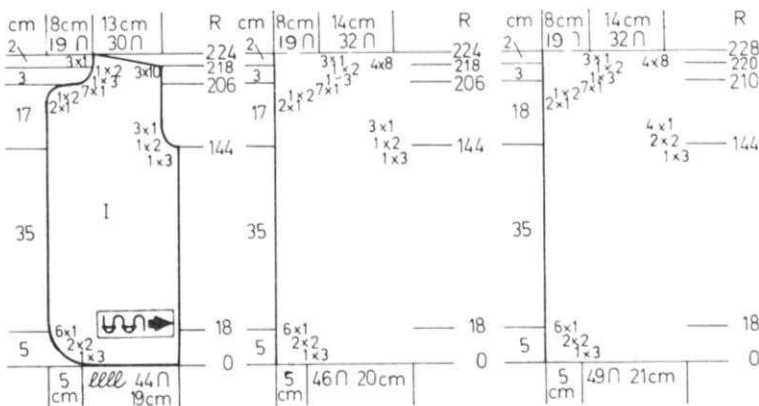

DK 879

BRAID TRIM FOR JACKET:

Make 2 cords using color 2 and 1 cord using color 1. Cast on 4 sts. and set your machine for knitting a cord. Use tight tension and knit long enough to go around Jacket edges (see picture). Braid all three cords together then sew onto jacket.

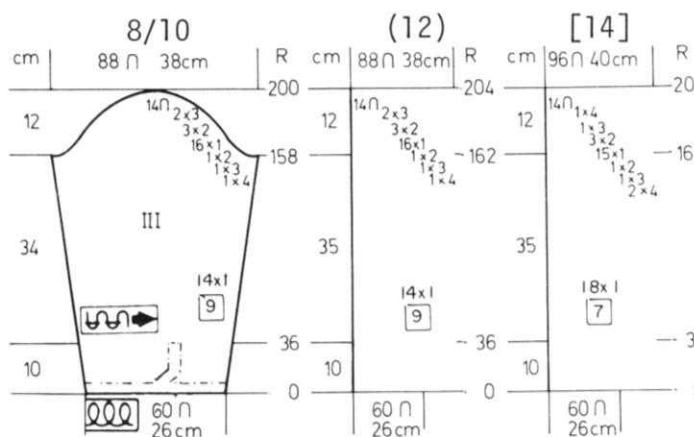

SLEEVES: III

Cast on 60 sts. and work Stockinette stitch. After Row 36, ON EACH SIDE, increase 1 st. every 9th row 14x. (every 9th row 14x). [every 7th row 18x]. After Row 158 (162) [162], SHAPE CAP: ON EACH SIDE, bind off 4 sts. 1x, 3 sts. 1x, 2 sts. 1x, 1 st. 16x, 2 sts. 3x, 3 sts. 2x. (Same as first size). [4 sts. 2x, 3 sts. 1x, 2 sts. 1x, 1 st. 15x, 2 sts. 3x, 3 sts. 1x, 4 sts. 1x]. After Row 200 (204) [204], bind off the remaining sts.

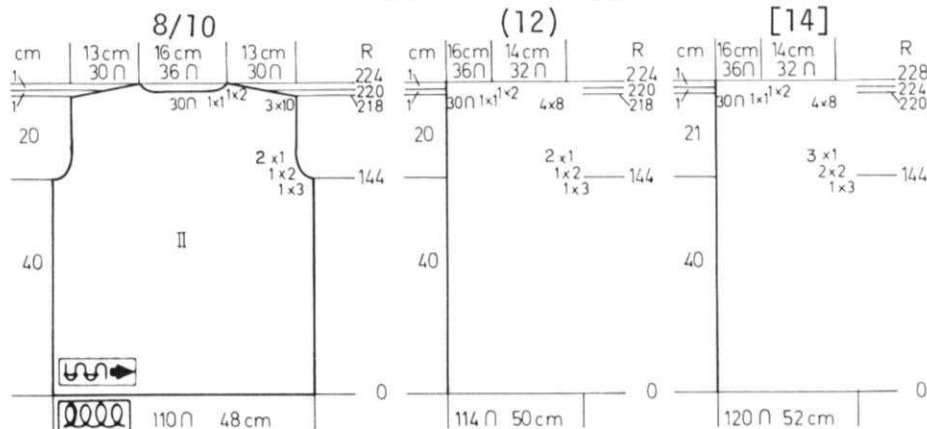

JACKET BACK: II

Cast on 110 (114) [120] sts. and work Stockinette stitch. Knit to Row 144. SHAPE ARMHOLE: ON EACH SIDE, bind off 3 sts. 1x, 2 sts. 1x, 1 st. 2x. (Same as first size) [3 sts. 1x, 2 sts. 2x, 1 st. 3x]. After Row 218 (218) [220], SHAPE SHOULDER (watch for neck shaping). ON EACH SIDE, bind off 10 sts. 3x, (8 sts. 4x), [8 sts. 4x]. AT THE SAME TIME, after Row 220 (220) [224], bind off the center 30 sts., put the needles on the left into holding position and complete the right side first. *ON NECK SIDE, bind off 1 st. 1x, 2 sts. 1x for all sizes. Bring the needles on the left into working position, knit 1 row to the left side, turn the Row Counter back to 220 (220) [224] and complete the left half. Follow the instructions from * and don't forget to complete the shoulder shaping.

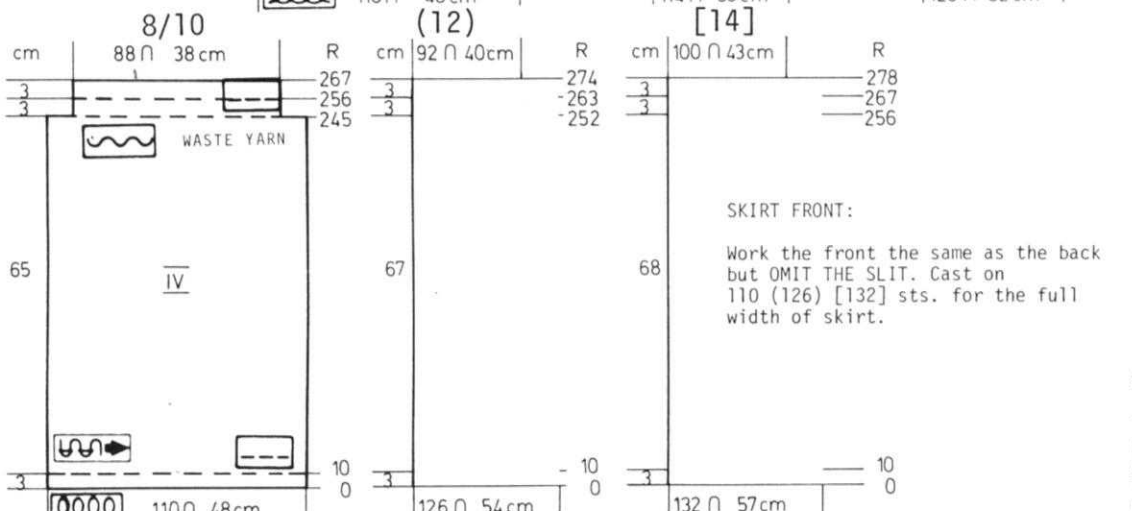

SKIRT FRONT:

Work the front the same as the back but OMIT THE SLIT. Cast on 110 (126) [132] sts. for the full width of skirt.

SKIRT BACK:

The back of skirt is worked in 2 sections to Row 83 because of the Slit. To the right of 0 needle, cast on 55 (63) [66] sts. and knit 9 rows. Knit the 10th row with a looser tension, then immediately go back to garment tension. After Row 10, ON THE LEFT SIDE, cast on 7 sts. Knit to Row 83. Bind off the 7 slit facing sts. and remove 7 more sts. onto contrast waste yarn. Put the remaining needles into holding position. ON THE LEFT side of 0, cast on 55 (63) [66] sts. and work the same as the right side. After Row 83, bind off the 7 slit facing sts. then hang the 7 sts. held on waste yarn onto the empty needles. Continue over all needles. Knit to Row 245 (252) [256]. Remove the sts. onto contrast waste yarn and hang them back onto the machine, decreasing to 88 (92) [100] sts. Knit to Row 267 (274) [278]. Bind off loosely.

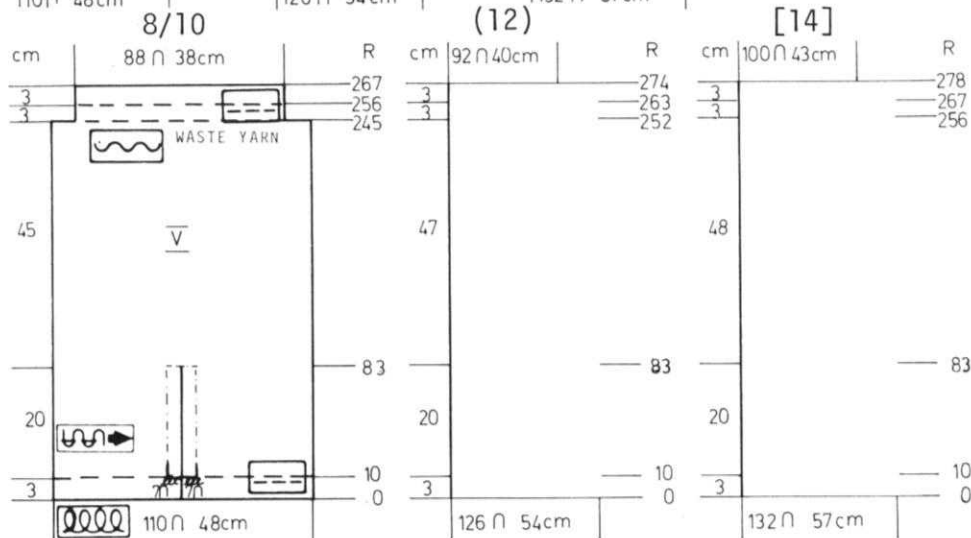

BE SURE TO READ PRINTED INSTRUCTIONS

DK 880

WOMAN'S PULLOVER

SIZES: 8/10 (12/14)
 YARN: Euro Sport
 GRAMS:
 color 1 150 200
 color 2 150 200
 color 3 150 200
 color 4 150 200
 color 5 100 150
 TENSION: 8 to 10
 GAUGE: 10 sts. 13 1/2 rows = 5 cm (2")

A Norwegian Design with Stockinette stitch. Bands are K1, P1 Ribbing. Punch your own Card for the Norwegian Design.

FINISHING: See General Instructions.

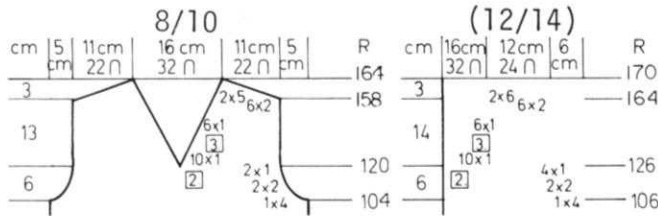

FRONT: I

Work the front the same as the back to Row 104 (106).
 SHAPE ARMHOLE same as the back and after Row 120 (126) divide in the center. Put the needles on the left into holding position and complete the right side first.

*ON NECK SIDE, decrease 1 st. every 2nd row 10x, every 3rd row 6x for both sizes.

After Row 158 (164) SHAPE SHOULDER SAME AS THE BACK.

Bring the needles on the left into working position, knit 1 row to the left side, turn the Row Counter back to 120 (126) and complete the left half. Follow the instructions from *.

BACK: II

Cast on 96 (104) sts. with color 1 and work 22 rows Ribbing. Continue in the Norwegian Design. Knit to Row 104 (106).

SHAPE ARMHOLE: ON EACH SIDE, bind off

4 sts. 1x, 2 sts. 2x, 1 st. 2x. (4 sts. 1x, 2 sts. 2x, 1 st. 4x). After Row 154 (160), bind off the center 24 sts., put the needles on the left into holding position and complete the right side first. Watch for SHOULDER SHAPING.

*ON NECK SIDE, bind off 21 sts. 2x and AT THE SAME TIME, after Row 158 (164), SHAPE SHOULDER: Bind off 2 sts. 6x, 5 sts. 2x. (2 sts. 6x, 6 sts. 2x).

Bring the needles on the left into working position, knit 1 row to the left side, turn the Row Counter back to 154 (160) and complete the left half. Follow the instructions from *.

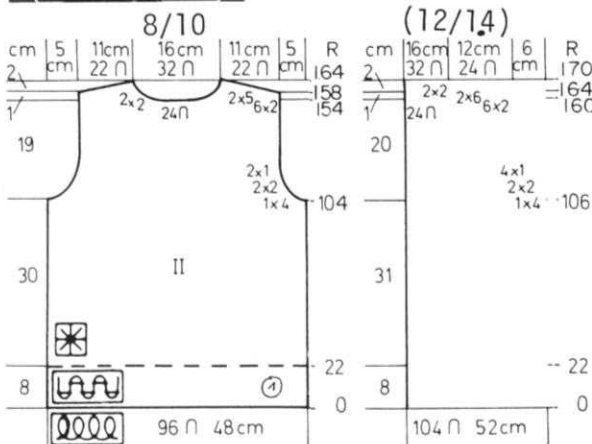
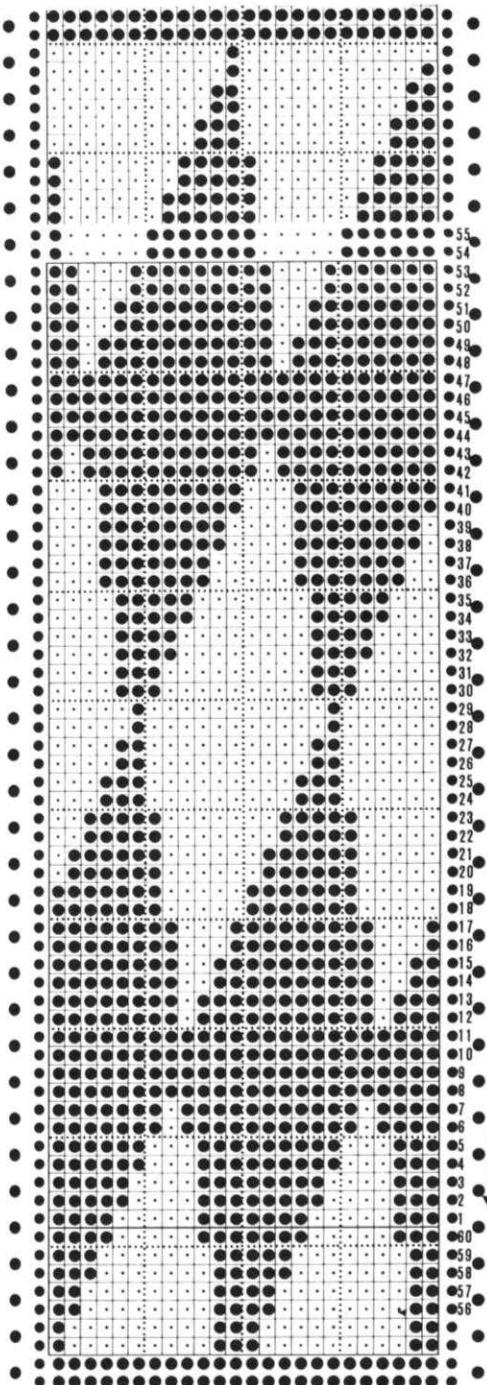

SLEEVES: III

With contrast waste yarn, cast on 64 (68) sts. After knitting 8 to 10 rows, change to garment yarn and work in Pattern. Put Counter at 22.

ON EACH SIDE, increase 1 st. every 16 row 6x. (every 13th row 8x).

After Row 120 (126) SHAPE CAP: ON EACH SIDE, bind off 4 sts. 1x, 2 sts. 2x, 1 st. 14x, 2 sts. 2x, 3 sts. 1x, 4 sts. 1x. (4 sts. 1x, 2 sts. 3x, 1 st. 15x, 2 sts. 2x, 3 sts. 1x, 4 sts. 1x). After Row 164 (172) bind off the remaining sts.

Pick up the sts. held on waste yarn, decreasing to 48 (52) sts. Work 22 rows Ribbing then bind off.

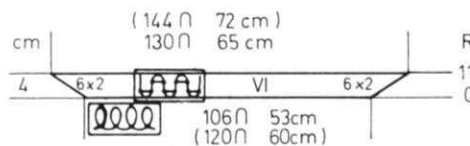
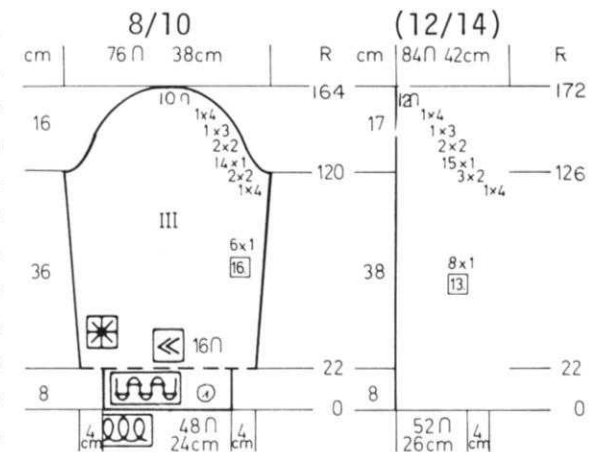

NECKBAND: VI

Cast on 106 (120) sts. and work in Ribbing. ON EACH SIDE, on every 2nd row, increase 2 sts. 6x. After Row 11, bind off.

A B Feeders
 18 Rows - C1 + C2
 18 Rows - C3 + C2
 36 Rows - C3 + C4
 18 Rows - C3 + C2
 18 Rows - C5 + C2
 18 Rows - C5 - Plain

KK 881



GIRL'S BIB JUMPER

SIZES: 2 to 4
 YARN: Fortissima
 GRAMS:
 color 1 200
 color 2 100
 TENSION: 8
 GAUGE: 13 sts. 20 rows = 5 cm (2")

Stockinette stitch with a Norwegian Design. Punch your own Card. K1, P1 Ribbing for the bands.

FINISHING: See General Instructions. Sew on straps and pull cord through at waist (see picture).

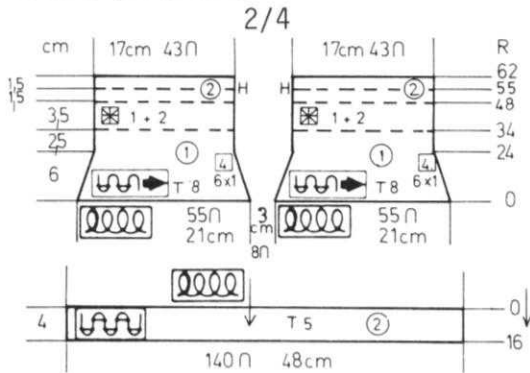

BIB:

Reduce the 70 sts. still on machine to 55 sts. and with color 1, tension 8, work Stockinette stitch. ON EACH SIDE, decrease 1 st. every 4th row 6x. After Row 34, work the Norwegian Design (Hearts) then continue with color 2 after Row 48. After Row 62, hang the first row of color 2 to form the hem and bind off. Hang the other half of skirt back onto machine and work bib in the same way.

With purl side facing you, pick up 32 sts. on side of bib and knit 6 rows Stockinette stitch with color 2. Bind off. Repeat for the 3 other side edges of bibs.

2/4

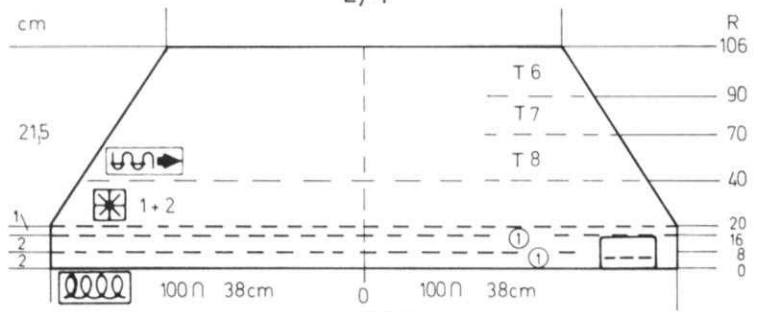

SKIRT:

Cast on 200 sts. with color 1 and work Stockinette stitch to Row 16. Hang the hem. Knit to Row 20 then continue in Norwegian Design (Elephants) to Row 40. Continue in Stockinette stitch. After Row 70, change to tension 7, and after Row 90, change to tension 6. After Row 106, remove the sts. onto contrast waste yarn.

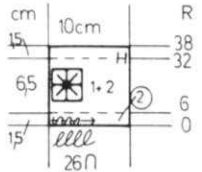

POCKET: Make 1

Cast on 26 sts. with color 2 and work 6 rows Stockinette stitch. Work the Elephant design, then knit to Row 38. Bind off.

WAIST BAND:

Cast on 140 sts. with color 2 and work 16 rows Ribbing with Tension 5. Transfer the ribber sts. to main machine, then hang the open sts. of the skirt onto these needle, doubling the sts. to 140 sts. Knit 1 row, then remove HALF the sts. onto waste yarn or take off on reversing bar. Continue with Bib.

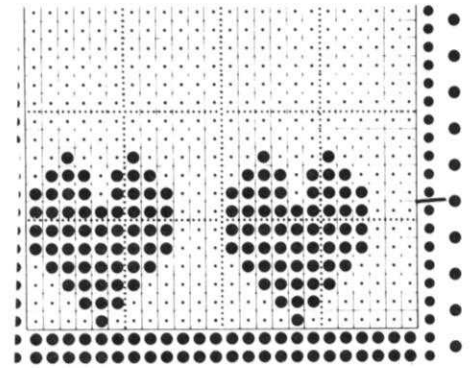
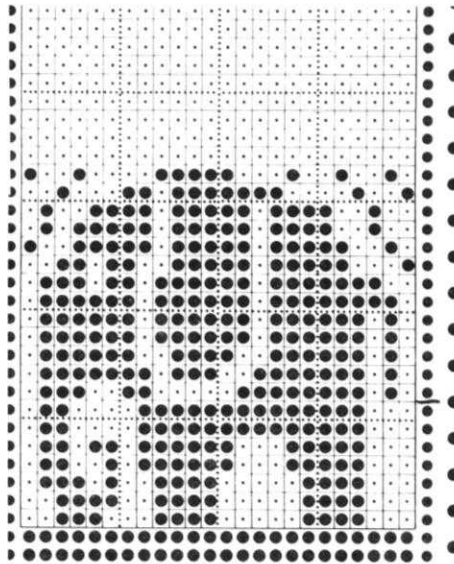

DK 882

WOMAN'S VEST

SIZES: 10 (12) [14]
 YARN: Crocus Crepe
 GRAMS:
 color 1 100 150 200
 color 2 100 150 150
 color 3 50 50 50
 color 4 50 50 50
 color 5 50 50 50
 TENSION: 6 to 8
 GAUGE: 12 sts. 17 rows = 5 cm (2")

Norwegian Designs using 3 different Punch Cards. The bands are K2, P2 Ribbing (or you can use K1, P1 if you prefer).

FINISHING: See General Instructions.



NECKBAND: VIII Make 2.

Cast on 116 sts. with color 2 and work 10 rows Ribbing. Bind off or remove onto waste yarn.

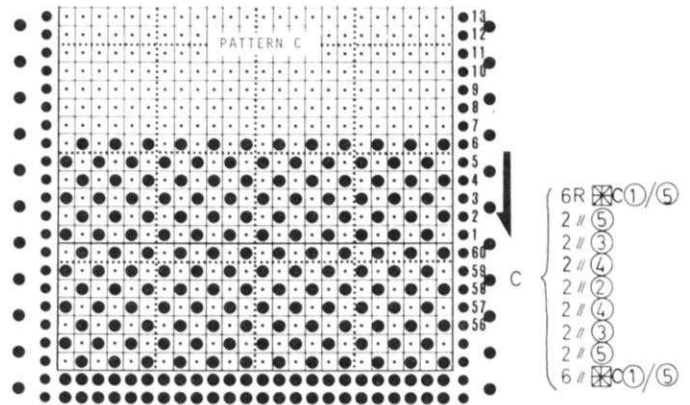
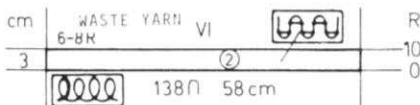

FRONT: I

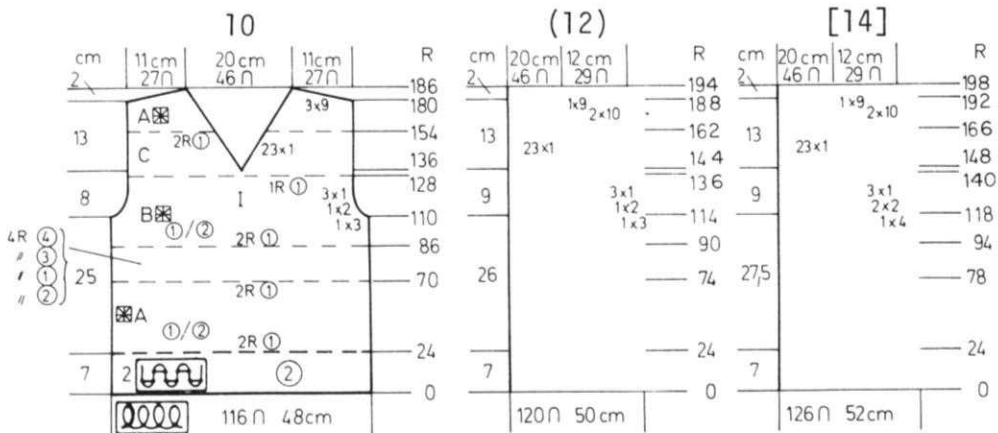

Cast on 116 (120) [126] sts. with color 2 and work 24 rows Ribbing. Knit 2 rows Stockinette stitch. (HINT: - SET PUNCH CARD A on 2nd row and hereafter when there are 2 rows Stockinette stitch before working in Pattern, always set the card on the 2nd row by setting KC and card on STOP. When you have knitted across to the right side, put Card on GO and push in MC Button and the 2nd color in feeder). Knit in PATTERN A as shown on the Chart ending with 2 rows stockinette stitch with color 1.

Work the color stripes as shown on the Chart and after Row 86, work 2 rows color 1 then work Pattern B. Always work to the rows as shown on the Chart for your size. AT THE SAME TIME, after Row 110 (114) [118], SHAPE ARMHOLE: ON EACH SIDE, bind off 3 sts. 1x, 2 sts. 1x, 1 st. 3x. (Same as first size)

[4 sts. 1x, 2 sts. 2x, 1 st. 3x]. After Row 128 (136) [140], continue with Pattern C and after Row 136 (144) [148], put half the sts. on the left into holding position and complete the right side first.

*ON NECK SIDE, decrease 1 st. every 2nd row 23x for all sizes and AT THE SAME TIME, after Row 154 (162) [166], continue in Pattern A. After Row 180 (188) [192], SHAPE SHOULDER: Bind off 9 sts. 3x.

(10 sts. 2x, 9 sts. 1x). [10 sts. 2x, 9 sts. 1x]. Bring the needles on the left into working position, knit 1 row to the left side, turn the Row Counter back to 136 (144) [148], and complete the left half. Follow the instructions from *

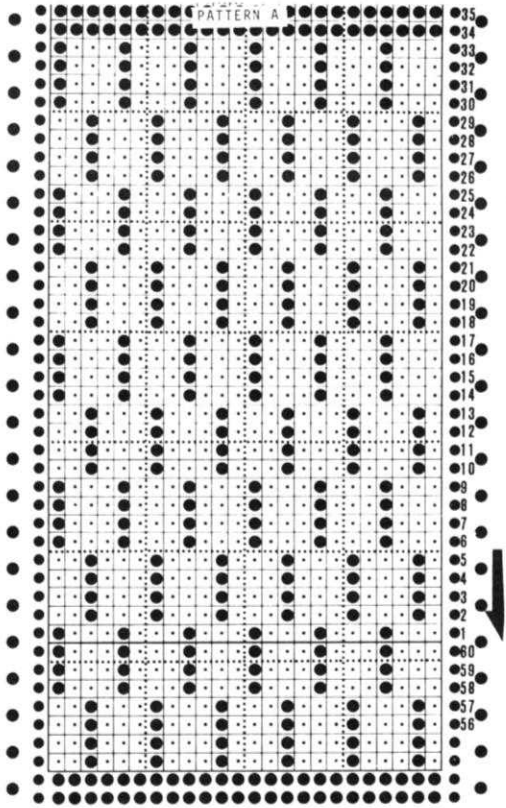
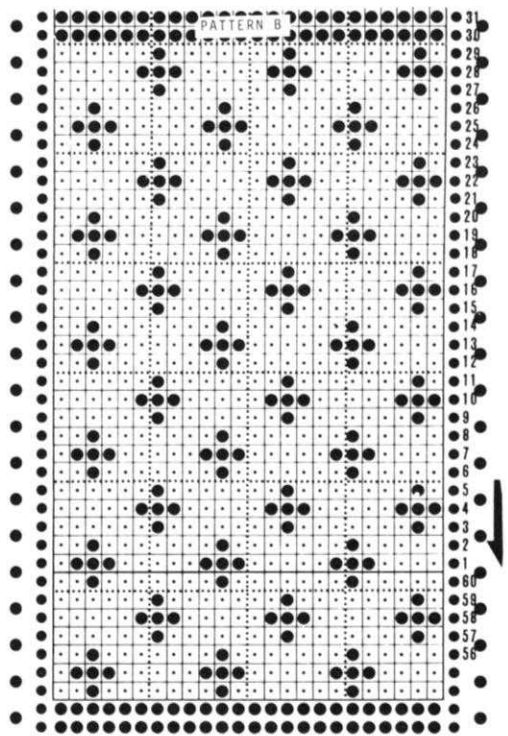

BACK: II

Work the back the same as the front but OMIT THE NECK SHAPING SPLIT.

After Row 180 (188) [192], bind off the center 30 sts. put the needles on the left into holding position and complete the right side first.

*SHAPE SHOULDER AND NECK AT THE SAME TIME.

FOR SHOULDER, make the bind offs same as the front and ON NECK SIDE, bind off for all sizes, 2 sts. 3x, 1 st. 2x.

Bring the needles on the left into working position, knit 1 row to the left side, turn the Row Counter back to 180 (188) [192] and complete the left half. Follow the instructions from *.

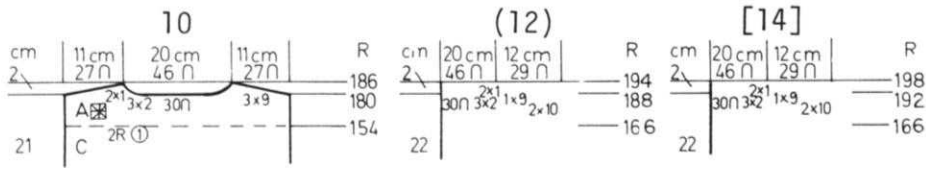

ARMBANDS: Make 2.

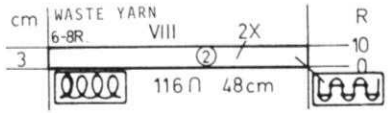

Cast on 138 sts. with color 2 and work 10 rows Ribbing. Bind off or remove onto waste yarn.

KK 883

CHILD'S PULLOVER

SIZES: 7 or 8
 YARN: Fortissima
 GRAMS: color 1 200, color 2 50, color 3 50, color 4 50
 TENSION: 6 to 8
 GAUGE: 13 1/2 sts. 20 rows = 5 cm (2")

Stockinette stitch with color stripes and Fair Isle Design. Bands are K1, P1 Ribbing.

FINISHING: See General Instructions.

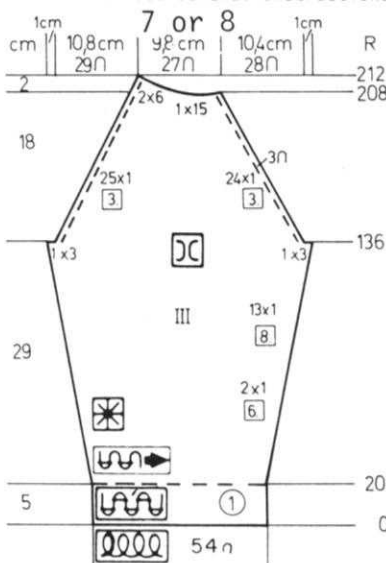

SLEEVES: III Make 1, reverse 1.

Cast on 54 sts. with color 1 and work 20 rows Ribbing. Continue in Pattern same as front and back.
 ON EACH SIDE, increase 1 st. every 6th row 2x, every 8th row 13x.
 After Row 136, ON EACH SIDE, bind off 3 sts. then decrease on the RIGHT (left for 2nd sleeve), 1 st. every 3rd row 24x - full fashion same as front and back and on the LEFT (right) 1 st. every 3rd row 25x.
 After Row 207, Work SHORT ROWS. ON OPPOSITE SIDE OF SLIDE, put into holding position 15 sts. 1x, then 6 sts. 2x.
 After Row 212, bind off all sts. Work the 2nd sleeve with reverse shapings.

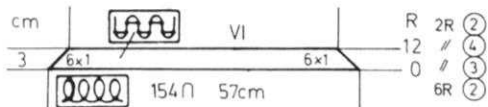

NECKBAND: VI

Cast on 154 sts. and work in Ribbing with color stripes as shown on the Chart.
 ON EACH SIDE, decrease 1 st. every 2nd row 6x. After Row 12, bind off or remove onto waste yarn.

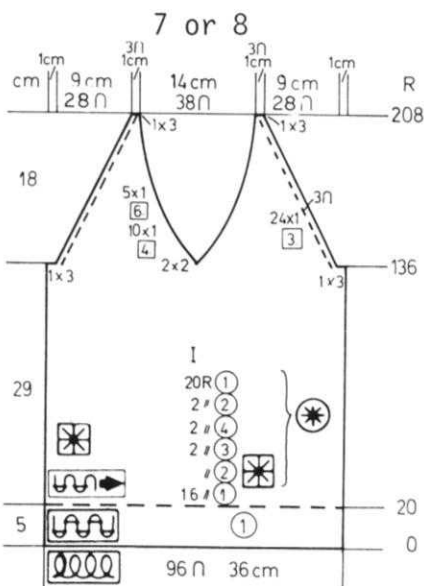

FRONT: I

Cast on 96 sts. with color 1 and work 20 rows Ribbing. Continue in Pattern as shown on the Chart.
 After Row 136, Divide in the center, put the needles on the left into holding position and complete the right side first.
 *SHAPE ARMHOLE AND NECK AT THE SAME TIME.
 ON ARM SIDE, bind off 3 sts. then decrease FULL FASHION (3 sts. in) 1 st. every 3rd row 24x AND ON NECK SIDE, bind off 2 sts. 2x, then decrease 1 st. every 4th row 10x, every 6th row 5x.
 After Row 208, bind off the remaining 3 sts.
 Bring the needles on the left into working position, knit 1 row to the left side, turn the Row Counter back to 136 and complete the left half. Follow the instructions from *.

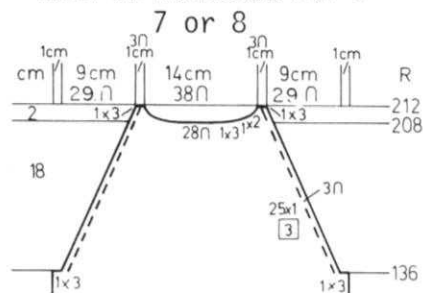

BACK: II

Work the back the same as the front to Row 136.
 SHAPE ARMHOLE: ON EACH SIDE, bind off 3 sts. 1x, then decrease 1 st. (full fashion same as front) every 3rd row 25x.
 After Row 208, bind off the center 28 sts., put the needles on the left into holding position and complete the right side first.
 *ON NECK SIDE, bind off 3 sts. 1x, 2 sts. 1x, then bind off the remaining 3 sts.
 Bring the needles on the left into working position, knit 1 row to the left side, turn the Row Counter back to 208 and complete the left half. Follow the instructions from *.

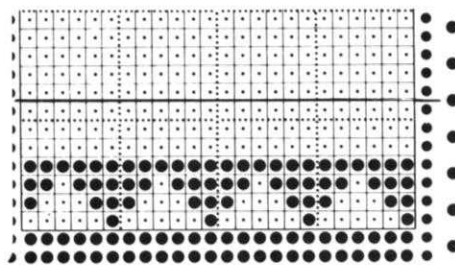

DK 884

WOMAN'S PULLOVER

SIZES: 8 (10) [12]
 YARN: Vienna
 GRAMS: 350 400 450
 TENSION: 8 to 10
 Band: 7 to 8
 GAUGE: 14 1/2 sts. 25 rows = 5 cm (2")

A Tuck stitch Pattern with every 4th needle out of work. Bands are K1, P1 Ribbing.

FINISHING: See General Instructions.

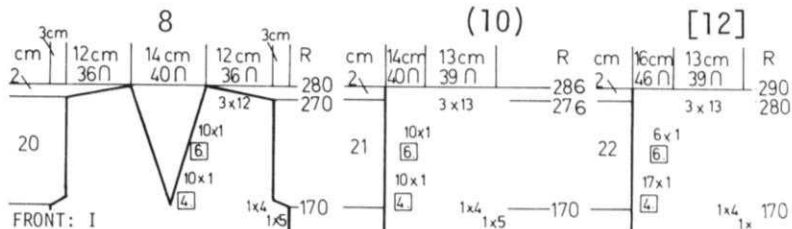

Work the front the same as the back to Row 170.
 SHAPE ARMHOLE same as the back BUT AT THE SAME TIME, divide in the center. Put the needles on the left into holding position and complete the right side first.
 *ON NECK SIDE, decrease 1 st. every 4th row 10x (10x) [17x], every 6th row 10x (10x) [6x]. After Row 270 (276) [280],

SHAPE SHOULDER same as the back. Bring the needles on the left into working position, knit 1 row in Pattern to the left side, turn the Row Counter back to 170 and complete the left half.
 SHAPE ARMHOLE and NECK AT THE SAME TIME and follow the instructions from * for neck shaping.

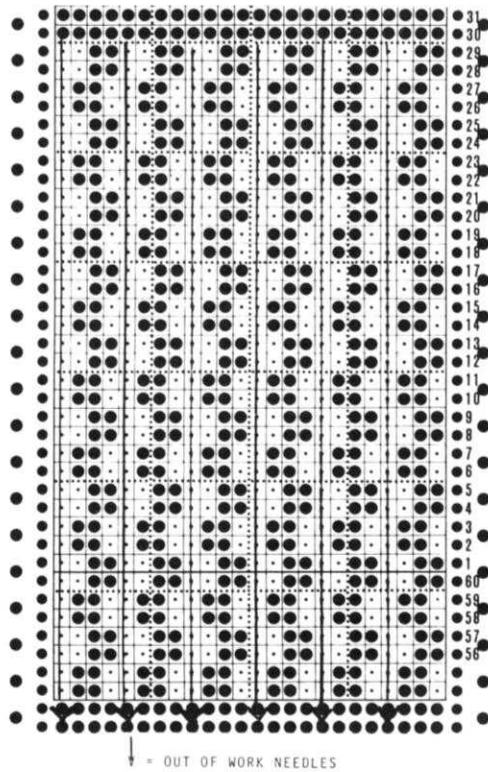

BELT:

Cast on 20 sts. and work Stockinette stitch for as long as you wish.

DK 886



WOMAN'S PULLOVER

SIZES: 8/10 (12/14)
YARN: Micaela
GRAMS:
 color 1 150 200
 color 2 150 150
 color 3 150 150
TENSION: 6 to 8
GAUGE: 11 sts. 18 rows = 5 cm (2")

Stockinette stitch with color stripes as shown on the Chart. Bands are K1, P1 Ribbing.

FINISHING: See General Instructions.

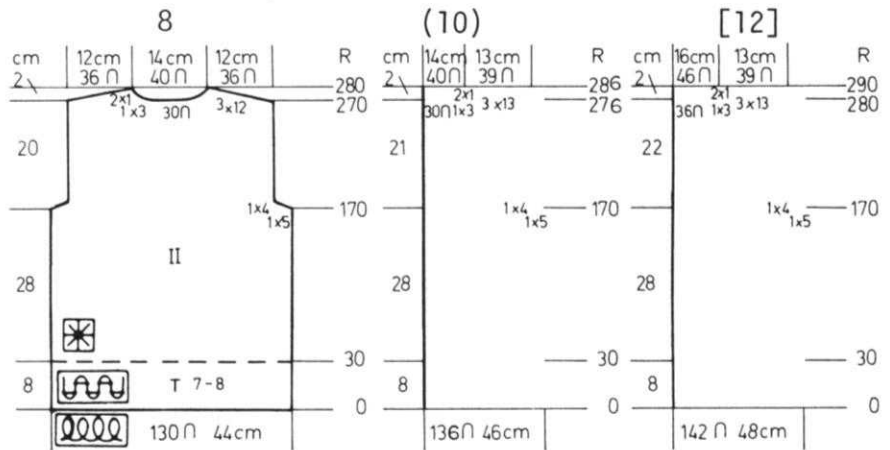

BACK: II

Cast on 130 (136) [142] sts. and work 30 rows Ribbing with lower tension. Remove the sts. from the machine onto waste yarn, then hang them back onto main machine with EVERY 4th NEEDLE OUT OF WORK. (If you want, you can work body of garment first, then the Ribbing later - but you must have the correct number of sts. as given for band and body of garment). Continue in Pattern.
SHAPE ARMHOLE: ON EACH SIDE, bind off 5 sts. 1x, 4 sts. 1x for all sizes.
 Knit to Row 270 (276) [280]
 Bind off the center 30 (30) [36]

sts., put the needles on the left into holding position and complete the right side first.
***SHAPE SHOULDER AND NECK AT THE SAME TIME.**
FOR SHOULDER, bind off 12 sts. 3x, (13 sts. 3x), [13 sts. 3x],
FOR NECK: Bind off 3 sts. 1x, 1 st. 2x for all sizes.
 Bring the needles on the left into working position, knit 1 row in Pattern to the left side, turn the Row Counter back to 270 (276) [280] and complete the left half. Follow the instructions from *.

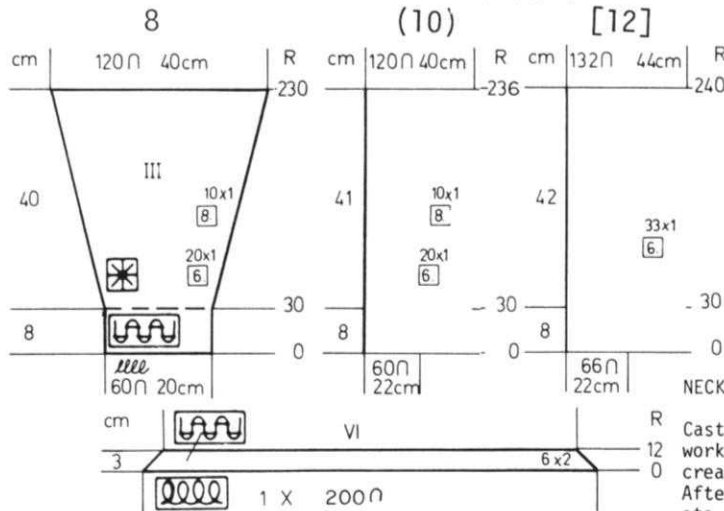

SLEEVES: III

Cast on 60 (60) [66] sts. and work 30 rows Ribbing. Continue in Pattern setting the needles with every 4th out of work same as front and back. ON EACH SIDE, increase 1 st. every 6th row 20x, every 8th row 10x. (every 6th row 20x, every 8th row 10x). [every 6th row 33x]. After Row 230 (236)[240], bind off.

NECKBAND: VI

Cast on 200 sts. (both beds) and work Ribbing. ON EACH SIDE, decrease 2 sts. 6x. After Row 12, bind off the remaining sts.

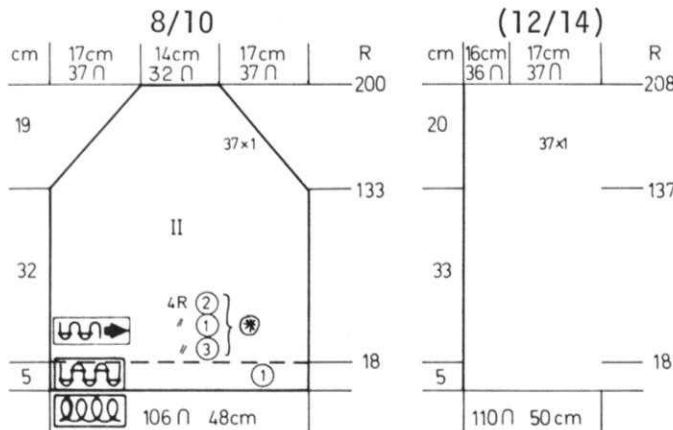

BACK: II

Cast on 106 (110) sts. with color 1 and work 18 rows Ribbing. Continue in Stockinette stitch with color stripes as shown on the Chart. Knit to Row 133 (137).
SHAPE RAGLAN: ON EACH SIDE, decrease 1 st. every 2nd row 37x. After Row 200 (208), bind off the remaining sts.



DK 886

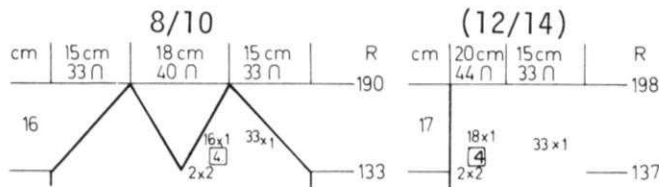

FRONT: I

Work the front the same as the back to Row 133 (137).
Divide in the center and put the needles on the left into holding position and complete the right side first.

*SHAPE RAGLAN AND NECK AT THE SAME TIME.

FOR RAGLAN, decrease 1 st. every 2nd row 33x.

FOR NECK, decrease 2 sts. 2x then 1 st. every 4th row 16x. (2 sts. 2x, then 1 st. every 4th row 18x).

Bring the needles on the left into working position, knit 1 row (watch stripe) to the left, turn the Row Counter back to 133 (137) and complete the left half. Follow the instructions from *.

NECKBAND:

Cast on 200 sts. with color 1 and work Stockinette stitch. ON EACH SIDE, decrease 1 st. every 2nd row 10x. After Row 20, bind off.

SLEEVES: III Make 1, reverse 1.

Use open Cast on with waste yarn.

Cast on 84 (92) sts., after knitting 8 to 10 rows, change to color 3 and put Counter at 0.

Continue with Stockinette stitch and color stripes as shown on the chart.

ON EACH SIDE, increase 1 st. every 18th row 7x.

After Row 126 (130), SHAPE RAGLAN.

ON THE RIGHT, decrease 1 st. every 2nd row 33x (35x) and

ON THE LEFT, decrease 1 st. every 2nd row 35x (37x).

After Row 184 (192), bind off 6 sts. 5x.

SLEEVE BANDS:

Hang the open sts. of the sleeve held on waste yarn, back onto the machine, decreasing to 56 (60) sts. Work 18 rows Ribbing. then bind off.

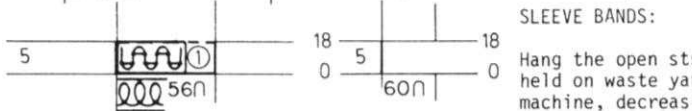
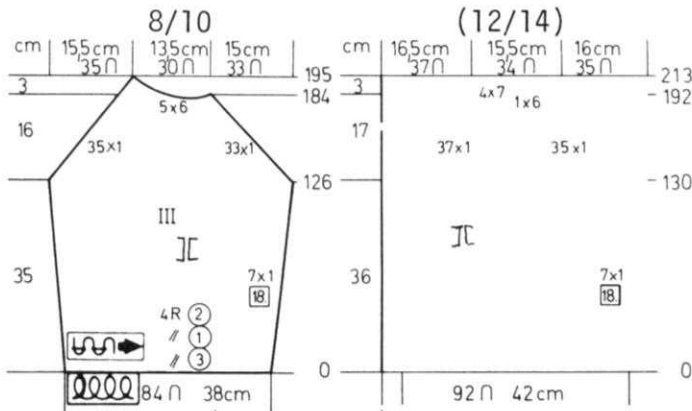
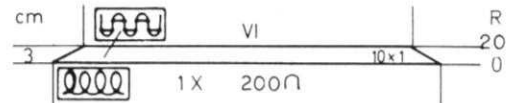

DK 885

WOMAN'S JACKET & SKIRT

SIZES: 8/10 (12/14) [16/18]
YARN: Vienna
GRAMS: 800 850 900
TENSION: 6 to 8
GAUGE: 15 sts. 18 rows = 5 cm (2")

Stockinette stitch with K1, P1 Ribbing for front and neck bands. Crochet trim.

FINISHING: See General Instructions. CROCHET TRIM:

ROW 1 - Into every 2nd st., work 1 double crochet, ch 1.

ROW 2 - 4 treble crochet into first double crochet,*ch 3, slip st. into first ch made (picot) 4 treble crochet into same double crochet, skip next double crochet, single crochet into next double crochet, skip next double crochet, skip next double crochet, 4 treble crochet into next double crochet. REPEAT from *.

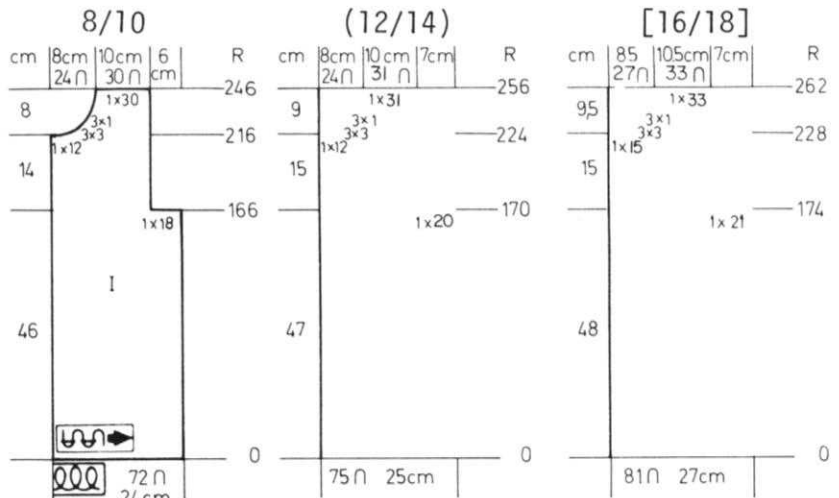

JACKET FRONT: I Make 1, reverse 1.

Cast on 72 (75) [81] sts. and work Stockinette stitch.

Knit to Row 166 (170) [174]. Bind off 18 (20) [21] sts. for armhole then knit to Row 215 (223) [227].

SHAPE NECK: Bind off 12 sts. 1x, 3 sts. 3x, 1 st. 3x. (Same as first size). [15 sts. 1x, 3 sts. 3x, 1 st. 3x]. After Row 246 (256) [262], bind off the remaining sts.

SLEEVES:

Cast on 108 (114) [120] sts. and work Stockinette stitch. ON EACH SIDE, increase 1 st. every 16th row 12x for all sizes. After Row 190 (194) [198], bind off the remaining sts.

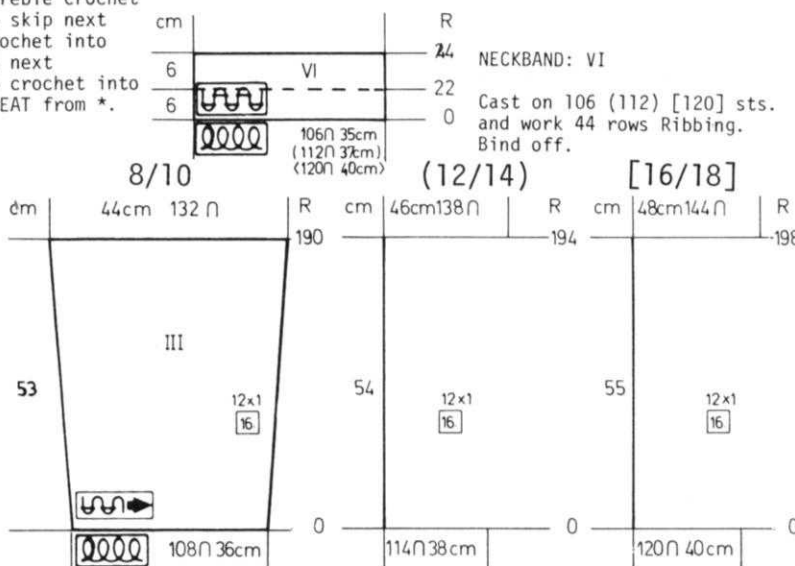

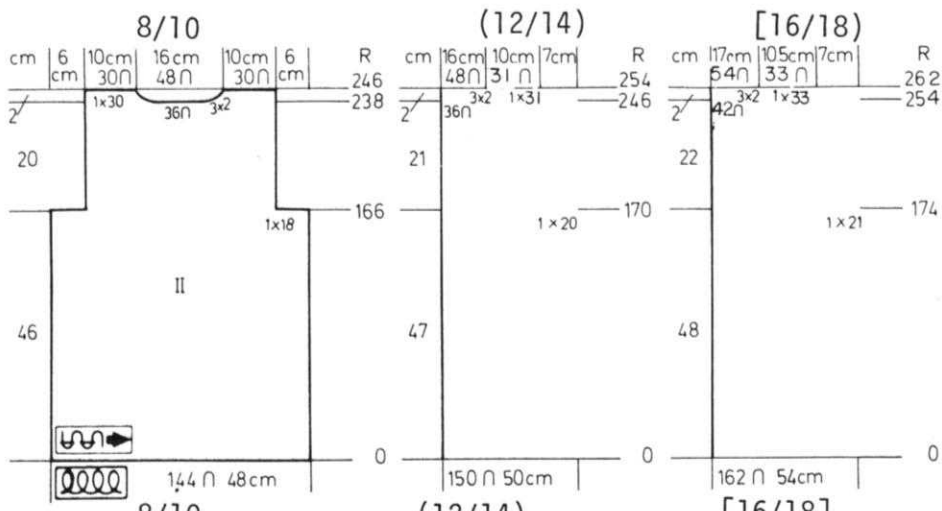

JACKET BACK: II

Cast on 144 (150) [162] sts. and work Stockinette stitch.
 Knit to Row 166 (170) [174].
SHAPE ARMHOLE: ON EACH SIDE, bind off 18 (20) [21] sts.
 Knit to Row 238 (246) [254].
 Bind off the center 36 (36) [42] sts. put the needles on the left into holding position and complete the right side first.
 *ON NECK SIDE, bind off 2 sts. 3x for all sizes.
 After Row 246 (254) [262], bind off the remaining sts.
 Bring the needles on the left into working position, knit 1 row to the left side, turn the Row Counter back to 238 (246) [254] and complete the left half. Follow the instructions from *.

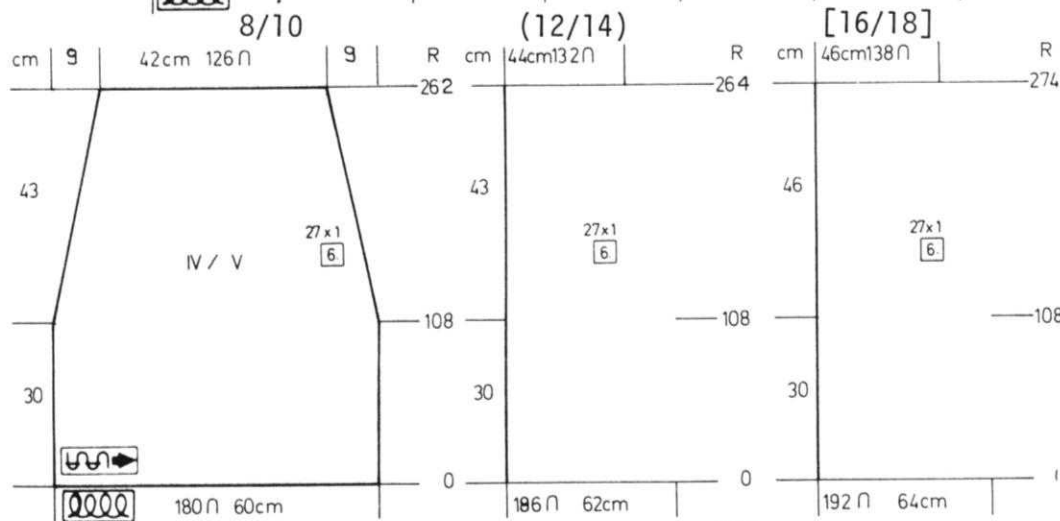

SKIRT: IV/V 2 sections the same.

Cast on 180 (186) [192] sts. and work Stockinette stitch.
 After Row 108, **ON EACH SIDE, decrease 1 st. every 6th row 27x** for all sizes.
 Mark Row 262 (264) [274] then knit 20 rows for Waistband and bind off. Or you can measure your waist and knit the waist band separately in 1 piece in which case, bind off after Row 262 (264) [274].

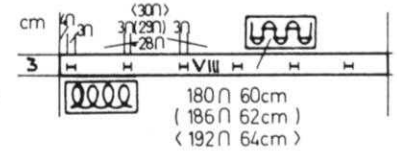

BELT:

Cast on 15 sts. and work K1, P1 Ribbing for 130 cm or as long as desired.

FRONT BANDS: VIII Make 2 and omit buttonholes in 2nd section.

Cast on 180 (186) [192] sts. and work K1, P1 Ribbing.
 After Row 6, **MAKE BUTTONHOLES.** Counting from the left, leave 4 sts., then make buttonhole over the next 3 sts. *skip 28 (29) [30] sts. and make buttonhole over next 3 sts. **REPEAT** from * until 6 buttonholes are completed.
 After Row 12, bind off or remove the sts. onto waste yarn.



- 2 rows color 1 - Stockinette
- 4 rows color 2 - Pattern
- 2 rows color 1 - Stockinette
- 4 rows color 3 - Pattern
- 2 rows color 1 - Stockinette
- 2 rows color 2 - Stockinette
- 4 rows color 3 - Pattern
- 2 rows color 2 - Stockinette
- 2 rows color 1 - Stockinette
- 2 rows color 3 - Stockinette
- 4 rows color 2 - Pattern
- 2 rows color 3 - Stockinette
- 2 rows color 1 - Stockinette
- 2 rows color 2 - Stockinette
- 4 rows color 3 - Pattern
- 2 rows color 2 - Stockinette

KK 888



GIRL'S DRESS

SIZE: 2 to 3 years.
 YARN: Micaela
 GRAMS: color 1 200
 color 2 few yards) not included
 color 3 few yards) in Kit.
 TENSION: 5 to 7
 GAUGE: 13 sts. 19 rows = 5 cm (2") in Stockinette. (Skirt-Knit side)
 13 sts. 26 rows = 5 cm (2") in Tuck Pattern. (Purl side-bodice)

Stockinette stitch with a Tuck Pattern for bodice and sleeve cuffs.

FINISHING: See General Instructions.
 Fold the cuff and sew to sleeve. Leave Cuff open. Work 1 row single crochet. Leave 1 shoulder part way open then work 3 rows single crochet around edges and sew on Snaps.
 Sew on sequins and beads for trim (See picture).

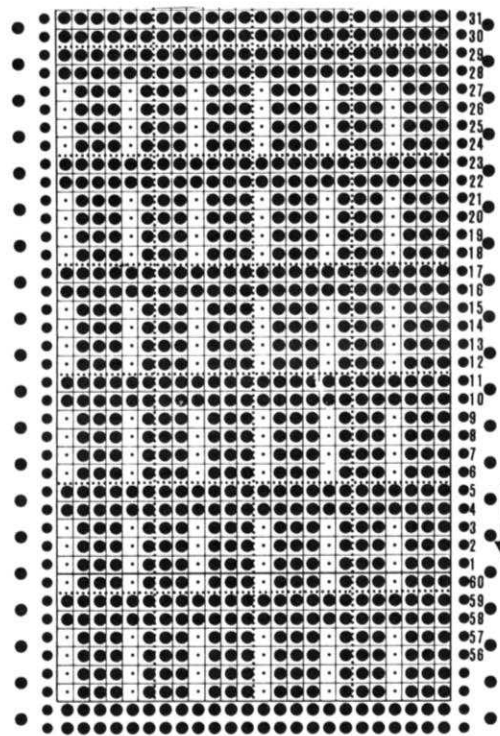

KK 888

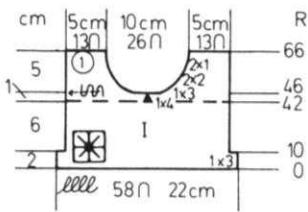

BODICE FRONT: I

Work the front the same as the back except for the NECK SHAPING. After Row 46, put half the sts. on the left into holding position and complete the right side first.

***ON NECK SIDE, bind off**
4 sts. 1x, 3 sts. 1x, 2 sts. 2x, 1 st. 2x.

After Row 66, bind off the remaining sts. Bring the needles on the left into working position, knit 1 row to the left side, turn the Row Counter back to 46 and complete the left half. Follow the instructions from *.

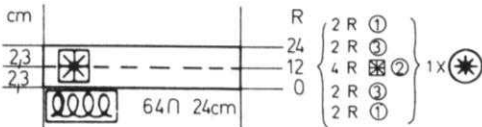

NECKBAND: (Knit side is the right side).

Cast on 64 sts. with color 1 and work in Pattern with color changes as shown on the Chart. After Row 24, bind off.

2 to 3 years

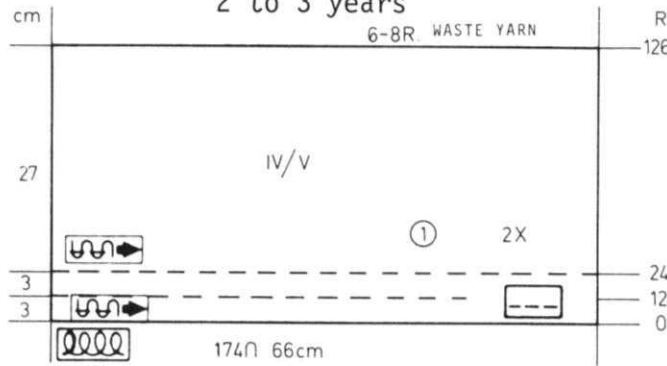

BODICE BACK: II

With knit side facing you, hang one skirt section back onto the machine, decreasing to 58 sts. Knit 1 row, then set Tuck Pattern from left to right. Put Counter at 0. Continue in Pattern. After Row 10, ON EACH SIDE, bind off 3 sts. After Row 42, continue in Stockinette stitch with color 1. After Row 66, bind off.

SKIRT SECTION (Make 2)

Cast on 174 sts. with color 1 and work Stockinette stitch. After Row 24, hang the hem. Knit to Row 126. Remove the sts. onto contrast waste yarn.

2 to 3 years

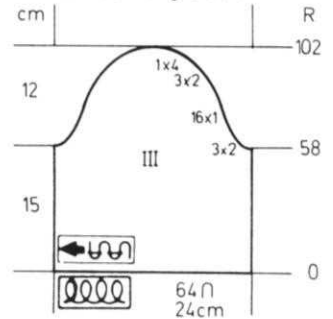

SLEEVES: III

Cast on 64 sts. with color 1 and work Stockinette stitch. After Row 58, SHAPE CAP: ON EACH SIDE, bind off 2 sts. 3x, 1 st. 16x, 2 sts. 3x, 4 sts. 1x.

SLEEVE CUFFS: Make 2.

Cast on 30 sts. and work in Pattern to Row 22. Continue in Stockinette stitch. After Row 26, hang the hem then knit to Row 46. Bind off.

DK 887

WOMAN'S TWIN SWEATER SET

SIZES: 8/10 (12/14)
YARN: Amore

| GRAMS: | 8/10 | (12/14) |
|----------|------|---------|
| Pullover | | |
| color 1 | 200 | 250 |
| color 2 | 50 | 50 |
| Jacket: | | |
| color 1 | 100 | 150 |
| color 2 | 100 | 150 |
| color 3 | 100 | 150 |
| color 4 | 150 | 200 |

TENSION: 6 to 8
GAUGE: 12 1/2 sts. 17 rows = 5 cm (2")

The Pullover is Stockinette stitch and is without sleeves. The Jacket is knitted sideways on the machine in color stripes as shown on the Chart. Bands for Jacket and Neckband of Pullover are seed stitch knitted by hand with No. 2 1/2 or 3 knitting needle - OR, you can use K1, P1 Ribbing - OR a simulated seed stitch by using No. 2 Card (KNITTING 840 machine owners) in Tuck Pattern. Push in ONLY 1 Tuck Button. You must reverse the knitting after working the Tuck stitch so the purl side of the tuck pattern is the right side. Waistband of Pullover is K1, P1 Ribbing.

FINISHING: See General Instructions. Make twisted Monks Cords and pull through sleeves and neck of Jacket.



8/10

(12/14)

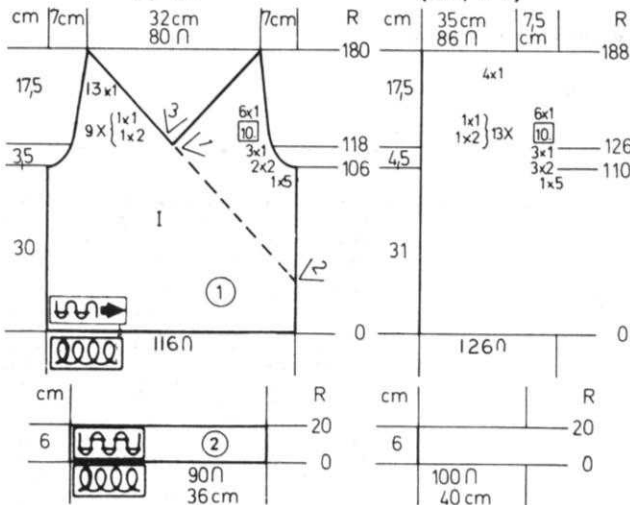

PULLOVER FRONT: I

Work the front the same as the back to Row 106 (110). SHAPE ARMHOLE same as the back BUT AT THE SAME TIME, after Row 118 (126) divide in the center. Put the needles on the left into holding position and complete the right side first.

***ON NECK SIDE decrease**
2 sts. 1x, 1 st. 1x and REPEAT till 9x (13x) in all then decrease 1 st. 13x (4x), continuing the armhole shaping.

Bring the needles on the left into working position and complete the left half. Put Counter at 118 (126) and follow the instructions from *.

PULLOVER WAISTBAND: Make 2.

Hang the open sts. of front back onto machine, decreasing to 90 (100) sts. With Color 2, work 20 rows Ribbing. Bind off. REPEAT for BACK.

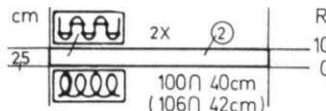

PULLOVER ARMBANDS: Make 2.

Cast on 100 (106) sts. with color 2 and work 10 row Ribbing. Bind off or remove onto waste yarn.

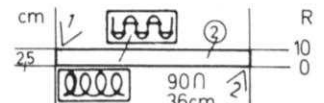

PULLOVER FRONT TRIM BAND

Cast on 90 sts. with color 2 and work 10 rows Ribbing. Bind off, or remove onto waste yarn.

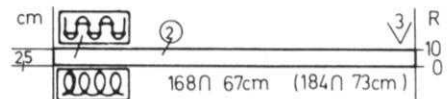

PULLOVER NECKBAND:

Cast on 168 (184) sts. with color 2 and work 10 rows Ribbing. Bind off or remove onto waste yarn.

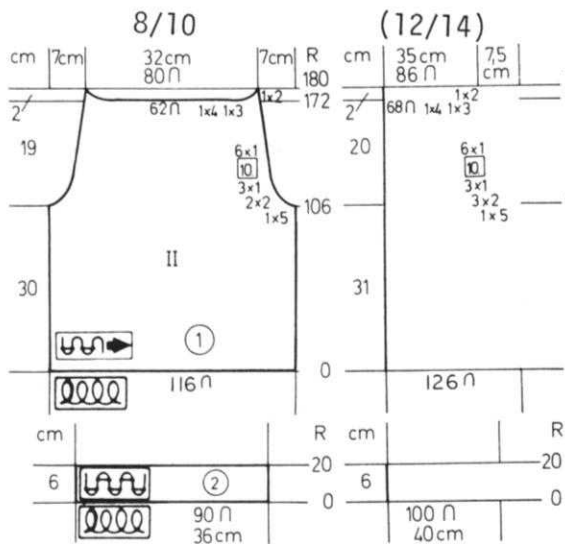

PULLOVER BACK: II

OPEN CAST ON with waste yarn. Cast on 116 (126) sts. and work 8 to 10 rows. Change to color 1 and put counter at 0. Continue in Stockinette stitch. Knit to Row 106 (110). SHAPE ARMHOLE: ON EACH SIDE, bind off 5 sts. 1x, 2 sts. 2x (3x), 1 st. 3x, 1 st. every 10th row 6x. After Row 172 (180), bind off the center 62 (68) sts., put the needles on the left into holding position and complete the right side first. *ON NECK SIDE, bind off 4 sts. 1x, 3 sts. 1x, 2 sts. 1x for both sizes. Bring the needles on the left into working position, knit 1 row to the left side, turn the Row Counter back to 172 (180) and complete the left half. Follow the instructions from *.

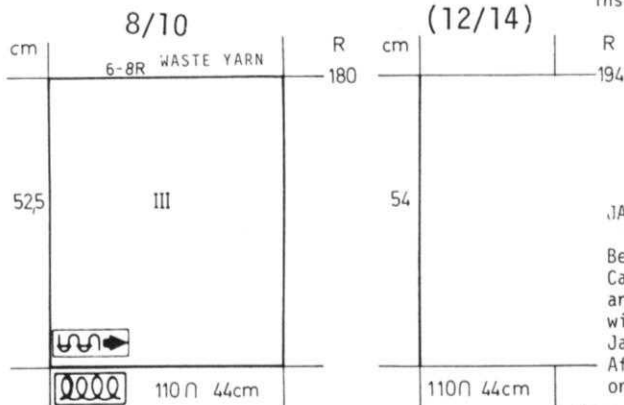
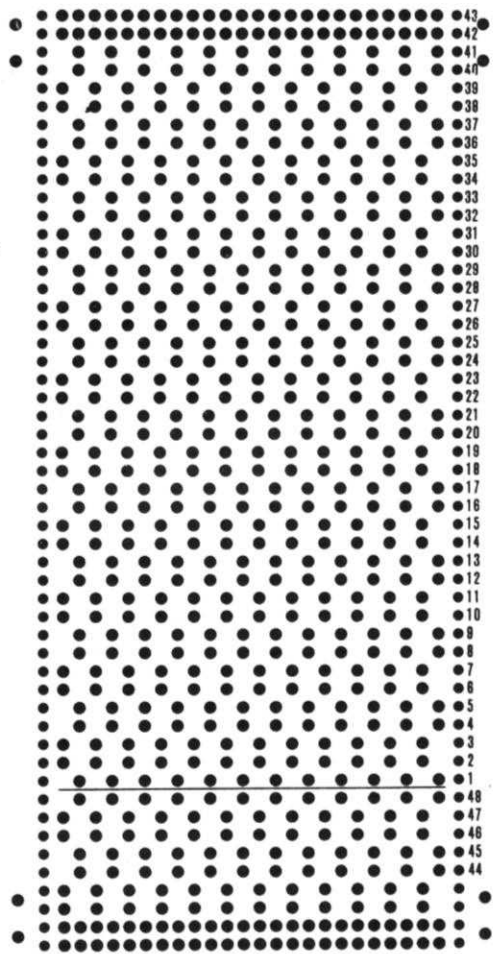

JACKET SLEEVES: III

Begin at TOP of Sleeve. Cast on 110 sts. with color 2 and work Stockinette stitch with color stripes same as Jacket. After Row 180 (194), remove onto waste yarn.

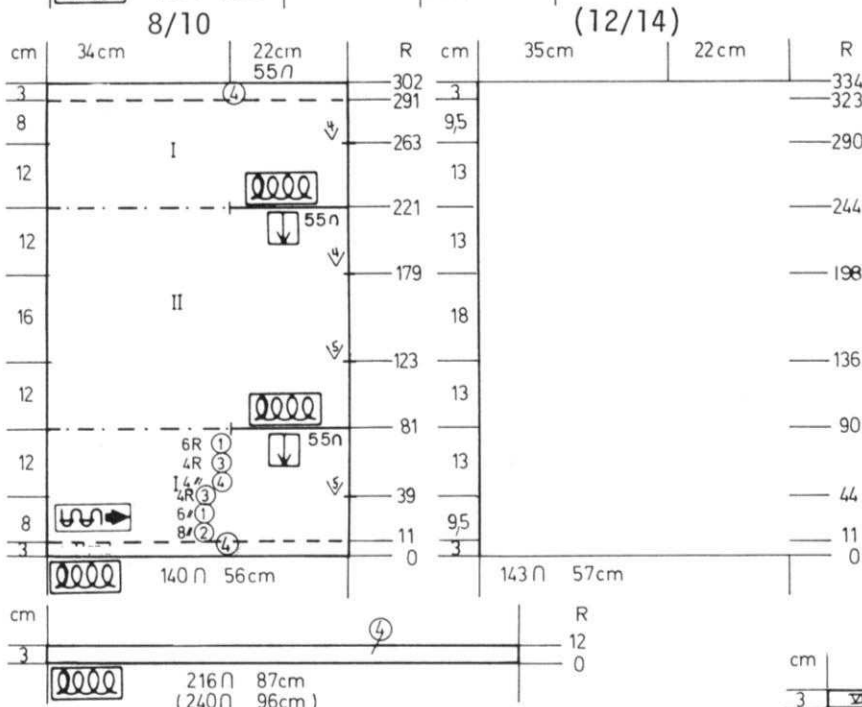

JACKET: Knitted sideways.

Cast on 140 (143) sts. with color 4 and work the band of your choice for 11 rows (See suggestions for bands in descriptive paragraph at beginning of Instructions). Continue in Stockinette stitch with color stripes as shown on the Chart. Mark Row 39 (44) on the right side edge with a bit of contrast yarn. After Row 81 (90), bind off 55 sts. at the right then immediately cast on 55 sts. (armhole). Mark Row 123 (136) at the right edge as you did before and again after After Row 179 (198). After Row 221 (244), bind off 55 sts. at the right then immediately cast on 55 sts. (armhole). Mark Row 263 (290) on the right as you did before, then knit to Row 291 (323). Work 11 rows of seed stitch by hand or K1, P1 Ribbing - or if you used the Tuck Card, reverse the knitting and work 11 rows Tuck stitch with color 4. Bind off.

JACKET LOWER BAND:

If you work seed stitch by hand you can cast on the full amount of sts. If you work the band in Tuck Stitch, you will have to make 2 pieces. Cast on 216 (240) sts. and work 12 rows color 4 in pattern of your choice same as you used for other bands.

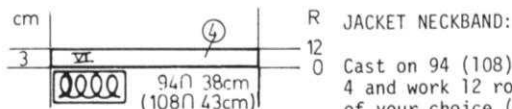

JACKET NECKBAND:

Cast on 94 (108) sts. with color 4 and work 12 rows in pattern of your choice (same as you used for other bands). Bind off.

JACKET SLEEVE BANDS:

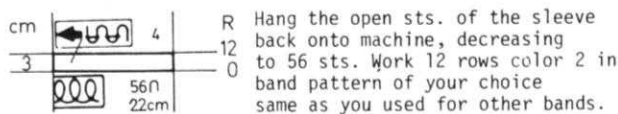

Hang the open sts. of the sleeve back onto machine, decreasing to 56 sts. Work 12 rows color 2 in band pattern of your choice same as you used for other bands.

KNITTING NEWS

PRACTICAL KNITTING HINTS

CAST ON COMB HEMS

Cast on comb hems can be made at the lower edge of of garments, at the neckline and sleeve edges. We have given you instructions before on how to make these hems, but here is some updated information on making decorative hems.

The Punch Card shown here is one you can punch and use whenever you want a decorative hem. It is punched for every other needle, every 3rd needle, every 4th needle and every 6th needle. The starting row for each is marked alongside the left edge and you will set your card on the line for the needle set up you want to use.

PICOT HEM

Suppose you want a picot hem using every other needle for the picot. Make a practice piece as follows:

1. Hang the Cast on Comb. Bring 60 needles into working position.
2. Bring every other needle from working position into "D" position beginning with the 2nd needle on the left. Push in BOTH PART BUTTONS.
3. Lower tension one number from the tension you will use for garment. Knit 1 row from right to left. Release Part Buttons and lower Cast on Comb.
4. Knit 10 rows.
5. Turn Tension 2 tensions HIGHER. Knit 1 row to the right side. Turn tension back to the one you were using.
6. Insert Punch Card and set on Line 1 (2 is the number on the left side of card which means every other needle). Leave the Card on GO and move the Lace Carriage across to the right then back to the left side. You will note that every other stitch has been transferred to the left needle.
7. Knit 12 rows.
8. Bring every other needle into "D" position beginning with the 1st needle on the left.
9. Lift the Cast on Comb horizontally (put weights on back of knitting to make it easier for you) and hang the sts. from the comb onto the needles in "D" position, then remove the Cast on Comb. Bring all needles into "E" position (to keep the sts. from floating off) and make sure Carriage is set for knitting all needles. Turn Tension to garment Tension and continue knitting your garment.

If you wish to have a picot hem at the top of a Blouse or Dress, work this hem as follows: This would be for a straight boat neck hem but you can also make it for a round neckline by hanging the neck sts. back onto the machine.

When you reach the place where you want the neck band, hang the Cast on Comb, then follow the instructions above from numbers 2 through 9 and after you have hung the sts. to form the hem, bind off. You can knit 1 very loose row using tension 10 then crochet bind off by pulling one stitch through the next. If you cannot turn the tension up high enough to crochet bind off LOOSELY, then you should knit this one row by hand. Place the yarn across the open latches and knit each stitch back to position "A" then leave it there until all the stitches are held against the back of the

needle bed. Now you can latch tool bind off. You could also bind off by using any of the methods given in your Instruction Manual, as long as the finished product looks good to you and there is plenty of stretch or give to the neckline.

If the yarn is heavy, you can, after the hem is hung and the needles have been brought to "E" position, take a tapestry needle, thread it with end of yarn then simply take the stitches off in an overcast manner onto the yarn, sewing through each stitch or doubled stitch on the machine.

When you have completed your hem, always take a rod or ruler, push it through the hem and give a good pull downwards.

HOLDING POSITION SCALLOPED HEM

The illustrated Punch Card can be used for Holding Position Scalloped Hems as follows:

- Follow the instructions for a Picot Hem from numbers 1 through 4.
5. Insert Punch Card and set it on Line 13 (every 4th needle). Set KC, then knit 1 row from left to right. Release KC and with a ruler or the straight edge of needle selector tool, bring all of the selected needles into holding position. Set the Cam Control on the Carriage for holding needles.
 6. Hang plenty of weights on your knitting, then knit 4, 6 or 8 rows (this will depend on the yarn you are using and how deep a scallop you want).
 7. Release the Holding Cam and knit 12 rows over all needles then follow the instructions for Picot Hem from 8 through 9.

For the scalloped hem at the top of a blouse or dress, follow the instructions from 2 through 4 for the Picot Hem, then follow 5, 6 and 7 for Scalloped Hem.

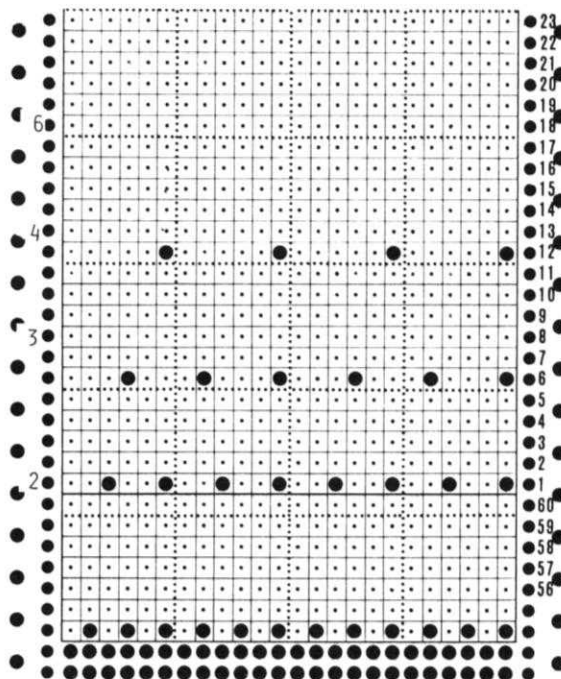

DISCOUNTED YARN KITS FOR THIS ISSUE

The Yarn Kits for this issue of KNITTING MAGAZINE are available at special discounts to our subscribers and the prices are only good until the next issue of the magazine. Be sure to check the colors available listed at the end of this NEWS-LETTER and make certain to give alternate colors.

| | | |
|-----------------------------|-------------|----------------|
| DK 863 - Yarn: Amore | | |
| SIZES: | 10/12 | (14) |
| Regular Price | \$10.25 | \$10.25 |
| Sale Price | 8.20 | 8.20 |
| Shipping Costs | 1.85 | 1.85 |
| DK 864 - Yarn Amore | | |
| SIZE: | 12 | |
| Regular Price | \$12.30 | |
| Sale Price | 9.84 | |
| Shipping Costs | 1.85 | |
| HP 865 - Yarn: Vienna | | |
| SIZES: | 38/40 | (42/44) |
| Regular Price | \$11.75 | \$14.10 |
| Sale Price | 9.40 | 11.28 |
| Shipping Costs | 1.85 | 1.85 |
| DK 866 - Yarn: Fortissima | | |
| SIZES: | 8/10 | (12) |
| Regular Price | \$23.22 | \$25.80 |
| Sale Price | 18.58 | 20.64 |
| Shipping Costs | 1.85 | 1.85 |
| KK 867 - Yarn Euro Sport | | |
| SIZES: | 8/10 | (12) |
| Regular Price | \$14.00 | \$15.75 |
| Sale Price | 11.20 | 12.60 |
| Shipping Costs | 1.85 | 1.85 |
| KK 868 - Yarn: Euro Sport | | |
| SIZES: | 5/6 | (8/10) |
| Regular Price | \$14.00 | \$15.75 |
| Sale Price | 11.20 | 12.60 |
| Shipping Costs | 1.85 | 1.85 |
| KK 869 - Yarn: Vienna | | |
| SIZES: | 6 | (8) |
| Regular Price | \$14.10 | \$16.45 |
| Sale Price | 11.28 | 13.16 |
| Shipping Costs | 1.85 | 1.85 |
| KK 870 - Yarn: Euro Sport | | |
| SIZES: | 4 | (6) |
| Regular Price | \$7.00 | \$7.00 |
| Sale Price | 5.60 | 5.60 |
| Shipping Costs | 1.85 | 1.85 |
| KK 871 - Yarn: Euro Sport | | |
| SIZES: | 5/6 | (7/8) |
| Regular Price | \$12.25 | \$14.00 |
| Sale Price | 9.80 | 11.20 |
| Shipping Costs | 1.85 | 1.85 |
| KK 872 - Yarn: Crocus Crepe | | |
| SIZES: | 6 to 12 Mo. | (12 to 24 Mo.) |
| Regular Price | \$18.90 | \$28.35 |
| Sale Price | 15.12 | 22.68 |
| Shipping Costs | 1.85 | 1.85 |
| KK 873 - Yarn: Amore | | |
| SIZES: | 6 to 12 Mo. | (12 to 24 Mo.) |
| Regular Price | \$8.20 | \$12.30 |
| Sale Price | 6.56 | 9.84 |
| Shipping Costs | 1.85 | 1.85 |
| HP 874 - Yarn: Crocus Crepe | | |
| SIZES: | 40/42 | |
| Regular Price | \$59.95 | |
| Sale Price | 47.88 | |
| Shipping Costs | 1.85 | |
| DK 875 - Yarn: Euro Sport | | |
| SIZE: | 12/14 | |
| Regular Price | \$15.75 | |
| Sale Price | 12.60 | |
| Shipping Costs | 1.85 | |
| DK 876 - Yarn: Euro Sport | | |
| SIZES: | 8/10 | (12/14) |
| Regular Price | \$17.50 | \$19.25 |
| Sale Price | 14.00 | 15.40 |
| Shipping Costs | 1.85 | 1.85 |

| | | | |
|-----------------------------|--------------|---------|---------|
| DK 877 - Yarn: Amore | | | |
| SIZES: | 12 | (14) | |
| Regular Price | \$26.65 | \$28.70 | |
| Sale Price | 21.32 | 22.96 | |
| Shipping Costs | 1.85 | 1.85 | |
| KK 878 - Yarn: Vienna | | | |
| SIZES: | 6 to 8 | | |
| Regular Price | \$18.80 | | |
| Sale Price | 15.04 | | |
| Shipping Costs | 1.85 | | |
| DK 879 - Yarn: Micaela | | | |
| SIZES: | 8/10 | (12) | [14] |
| Regular Price | \$36.64 | \$38.93 | \$38.93 |
| Sale Price | 29.31 | 31.14 | 31.14 |
| Shipping Costs | 1.85 | 1.85 | 1.85 |
| DK 880 - Yarn: Euro Sport | | | |
| SIZES: | 8/10 | (12/14) | |
| Regular Price | \$24.50 | \$33.25 | |
| Sale Price | 19.60 | 26.60 | |
| Shipping Costs | 1.85 | 1.85 | |
| KK 881 - Yarn: Fortissima | | | |
| SIZES: | 2/4 | | |
| Regular Price | \$15.48 | | |
| Sale Price | 12.39 | | |
| Shipping Costs | 1.85 | | |
| DK 882 - Yarn: Crocus Crepe | | | |
| SIZES: | 10 | (12) | [14] |
| Regular Price | \$22.05 | \$28.35 | \$28.35 |
| Sale Price | 17.64 | 22.68 | 22.68 |
| Shipping Costs | 1.85 | 1.85 | 1.85 |
| KK 883 - Yarn: Fortissima | | | |
| SIZE: | 7/8 | | |
| Regular Price | \$18.06 | | |
| Sale Price | 14.45 | | |
| Shipping Costs | 1.85 | | |
| DK 884 - Yarn: Vienna | | | |
| SIZES: | 8 | (10) | [12] |
| Regular Price | \$16.45 | \$18.80 | \$21.15 |
| Sale Price | 13.16 | 15.04 | 16.92 |
| Shipping Costs | 1.85 | 1.85 | 1.85 |
| DK 885 - Yarn: Vienna | | | |
| SIZES: | 8/10 | (12/14) | [16/18] |
| Regular Price | \$37.60 | \$39.95 | \$42.30 |
| Sale Price | 30.08 | 31.96 | 33.84 |
| Shipping Costs | 1.85 | 1.85 | 1.85 |
| DK 886 - Yarn: Micaela | | | |
| SIZES: | 8/10 | (12/14) | |
| Regular Price | \$20.61 | \$22.90 | |
| Sale Price | 16.50 | 18.32 | |
| Shipping Costs | 1.85 | 1.85 | |
| DK 887 - Yarn: Amore | | | |
| SIZES: | 8/10 | (12/14) | |
| Regular Price | \$28.70 | \$38.95 | |
| Sale Price | 22.96 | 31.16 | |
| Shipping Costs | 1.85 | 1.85 | |
| KK 888 - Yarn: Micaela | | | |
| SIZE: | 2 to 3 years | | |
| Regular Price | \$ 8.20 | | |
| Sale Price | 6.56 | | |
| Shipping Costs | 1.85 | | |

CHOOSE YOUR YARN KITS FROM THE FOLLOWING COLORS

| | |
|------------------------|---|
| <u>AMORE</u> | White, Dark Green, Pink, Rust, Red, Coral |
| <u>FORTISSIMA</u> . . | White, Black, Red, Tan, Brown, Dark Green, Grey, Beige Tweed, Green Tweed, Blue Tweed |
| <u>MICAELA</u> | White Black, Turquoise, Tan Brown, Orange, Peach, Sea Green, Grass Green, Yellow |
| <u>VIENNA</u> | White, Black, Lt. Green, Lilac, Ice Blue, Peach, Coral, Yellow, Brown, Moss, Beige, Rust, Medium Blue, Teal Blue, Red, Burgundy |
| <u>EURO SPORT</u> . . | White, Black, Green Tweed, Lemon Yellow, Blue Tweed, Moss, Navy, Brown, Rose |
| <u>CROCUS CREPE</u> . | Black, Red, Navy, Sky Blue, Tan Burnt Orange, Yellow |

COMPUKNIT KH 910

ILLUSTRATED INSTRUCTION MANUAL
SHOWS EXACTLY HOW TO PROGRAM
THE CONTROL PANEL...

PATTERN VARIATION

1 2 3 4 5 6 7 KH
KRC

PATTERN SELECTOR

READY ERROR

PATTERN POSITION

1 2 3 4 5 6 7 8 9 0 M

CF CR RR CF

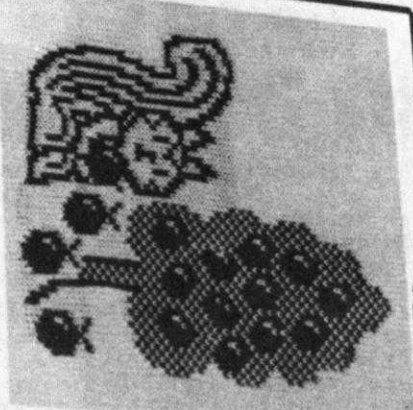

Card No. 3-13

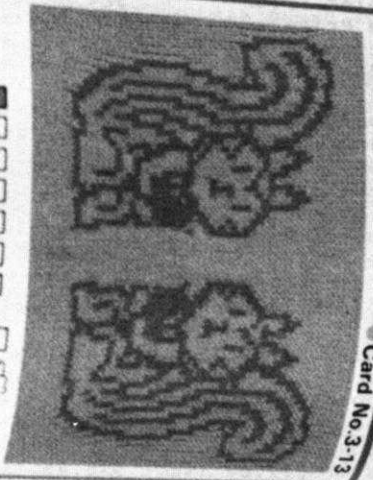

Card No. 3-13

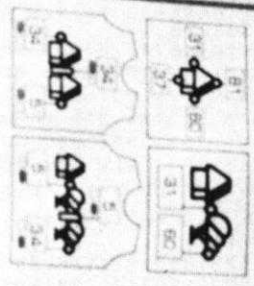
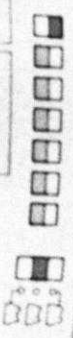

Card No. 4-15

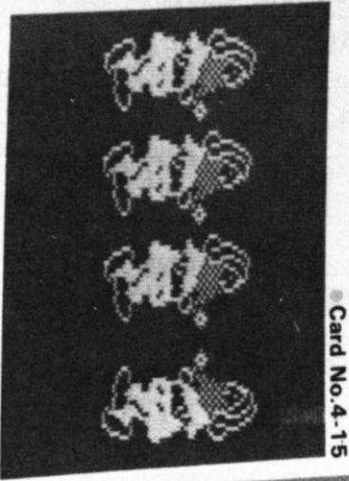
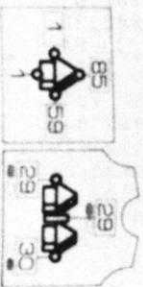

Card No. 4-15

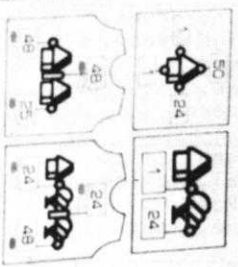
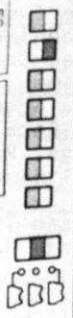

DK 876





KK 867

KK 868

HP 874

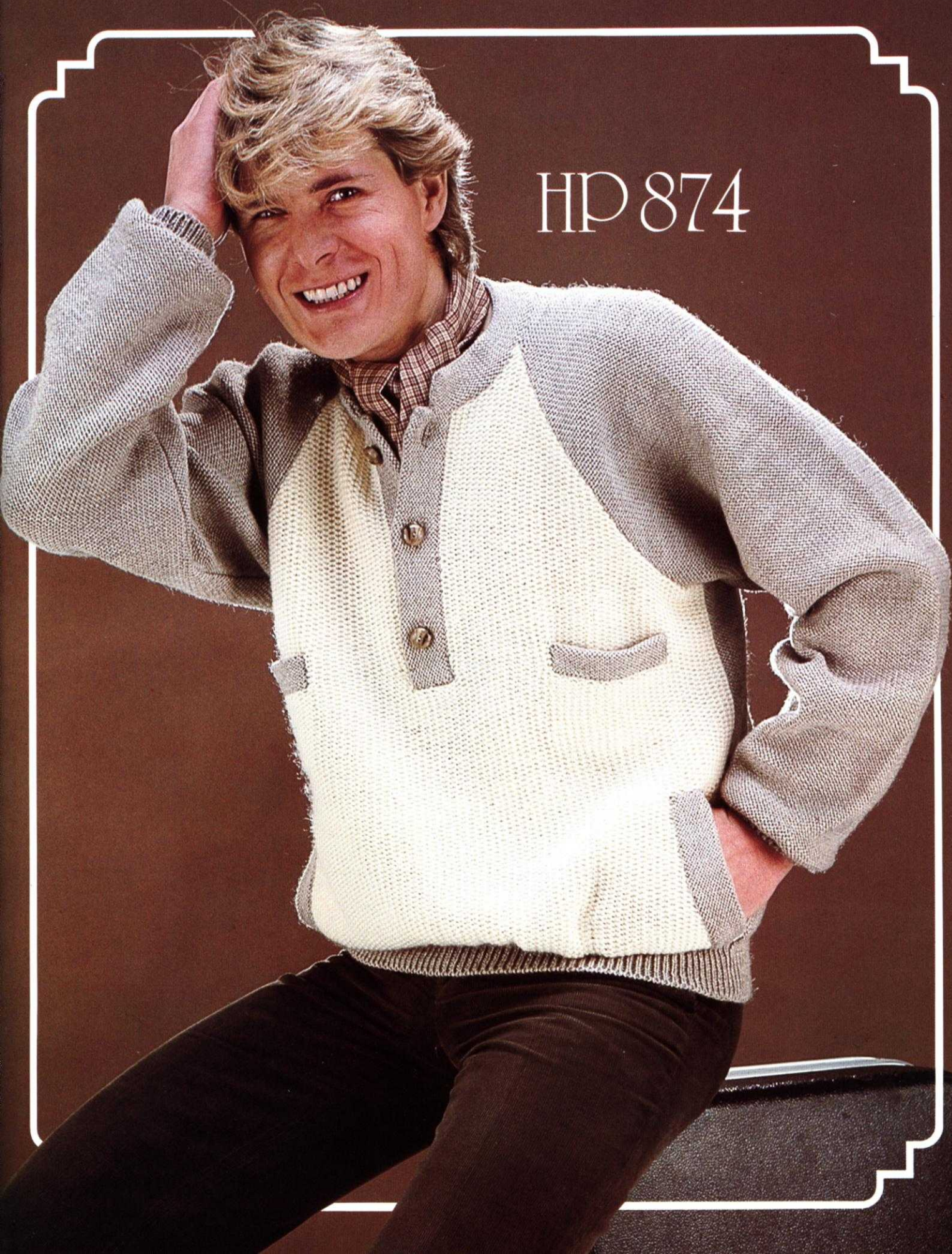

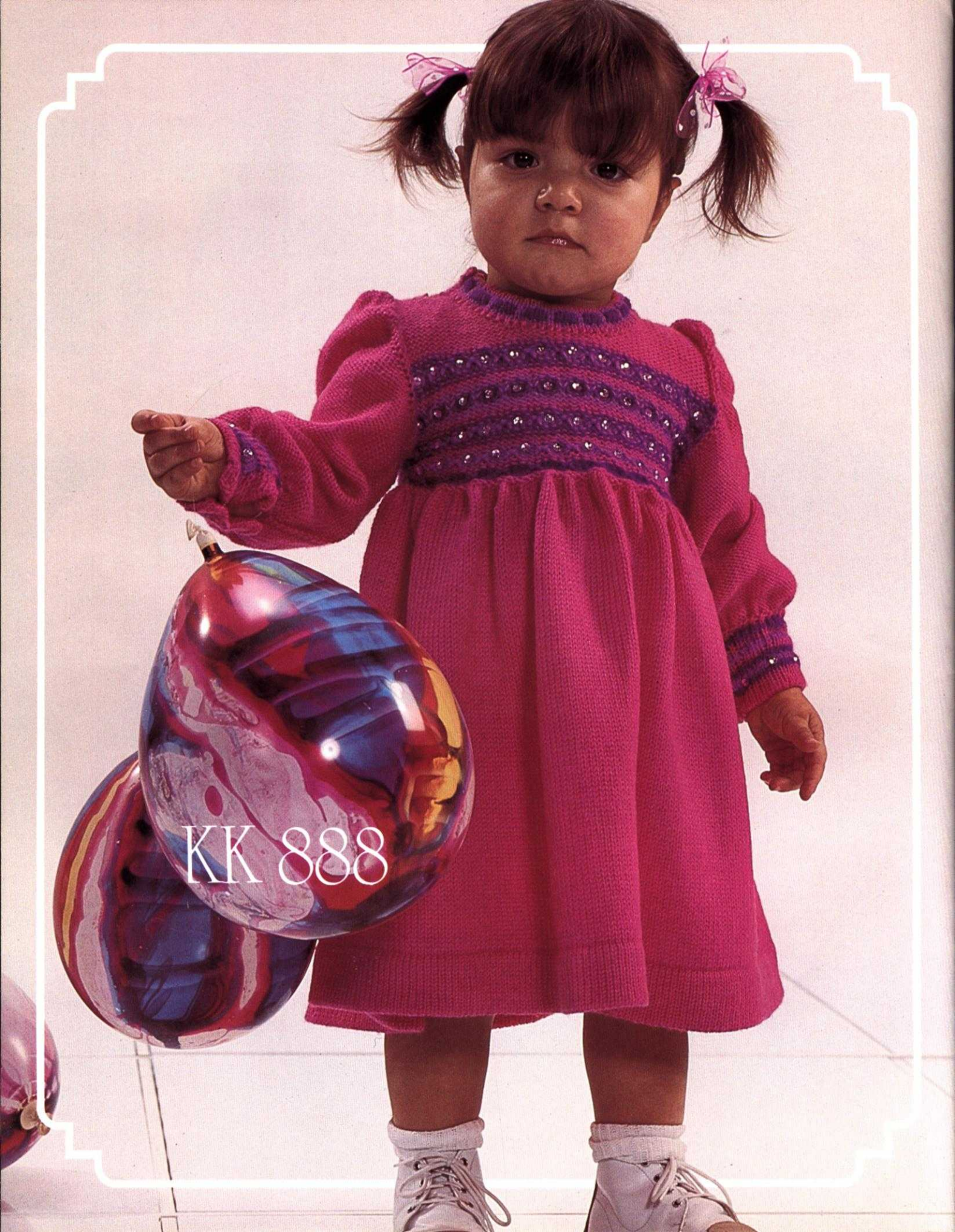

KK 888

KK 872

KK 873



KK 883



KK 871

KK 870

KK 869

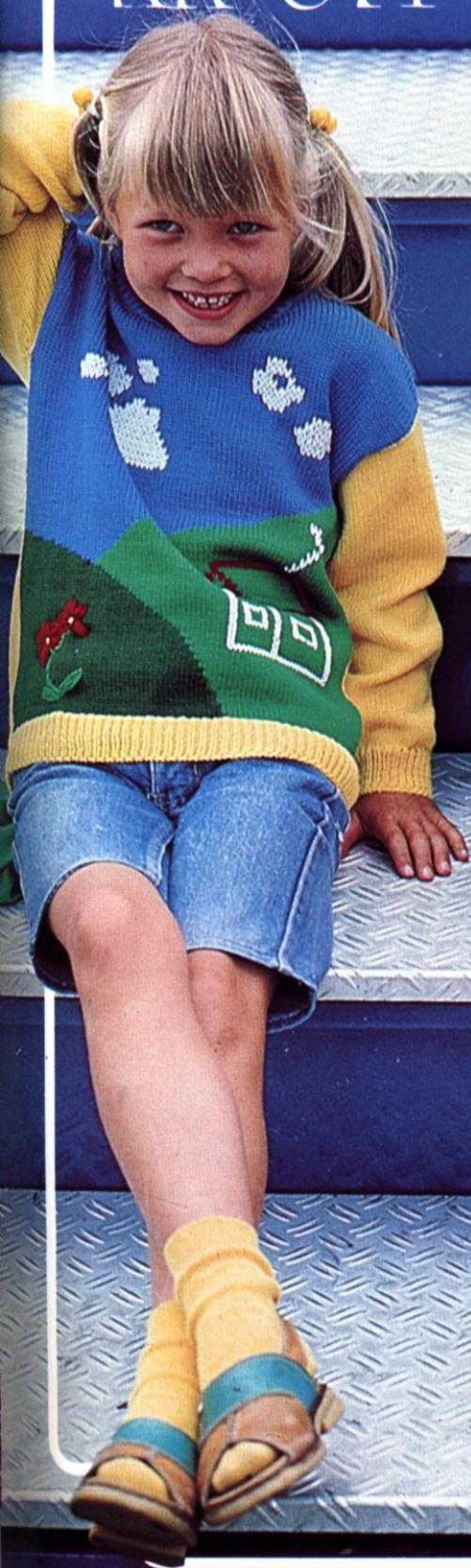

KK 881



KK 878



DK 885

