

16-2

knitking

magazine

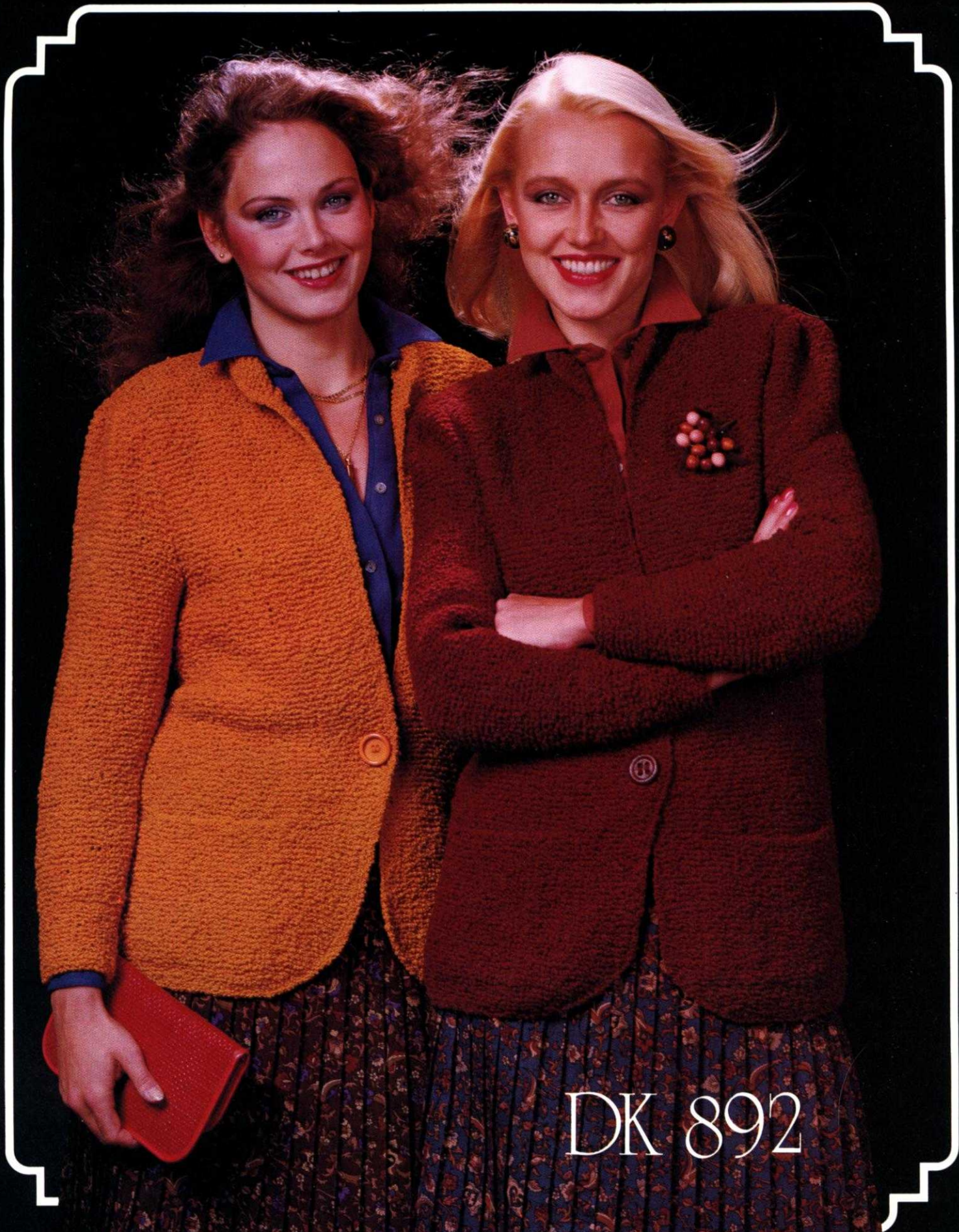



DK 892

DK 890



DK 889



DK 909



DK 902

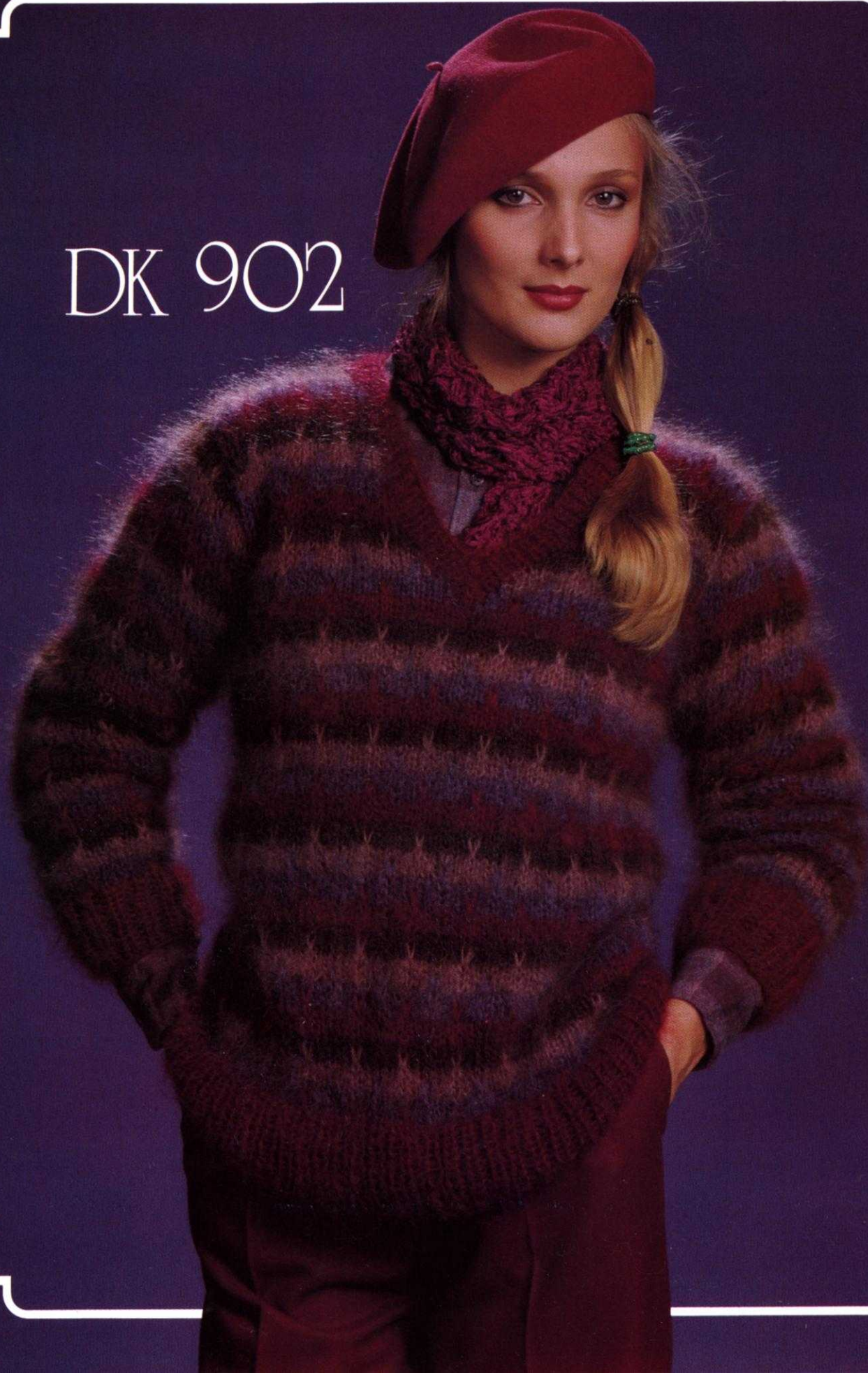

DK 896



DK 904

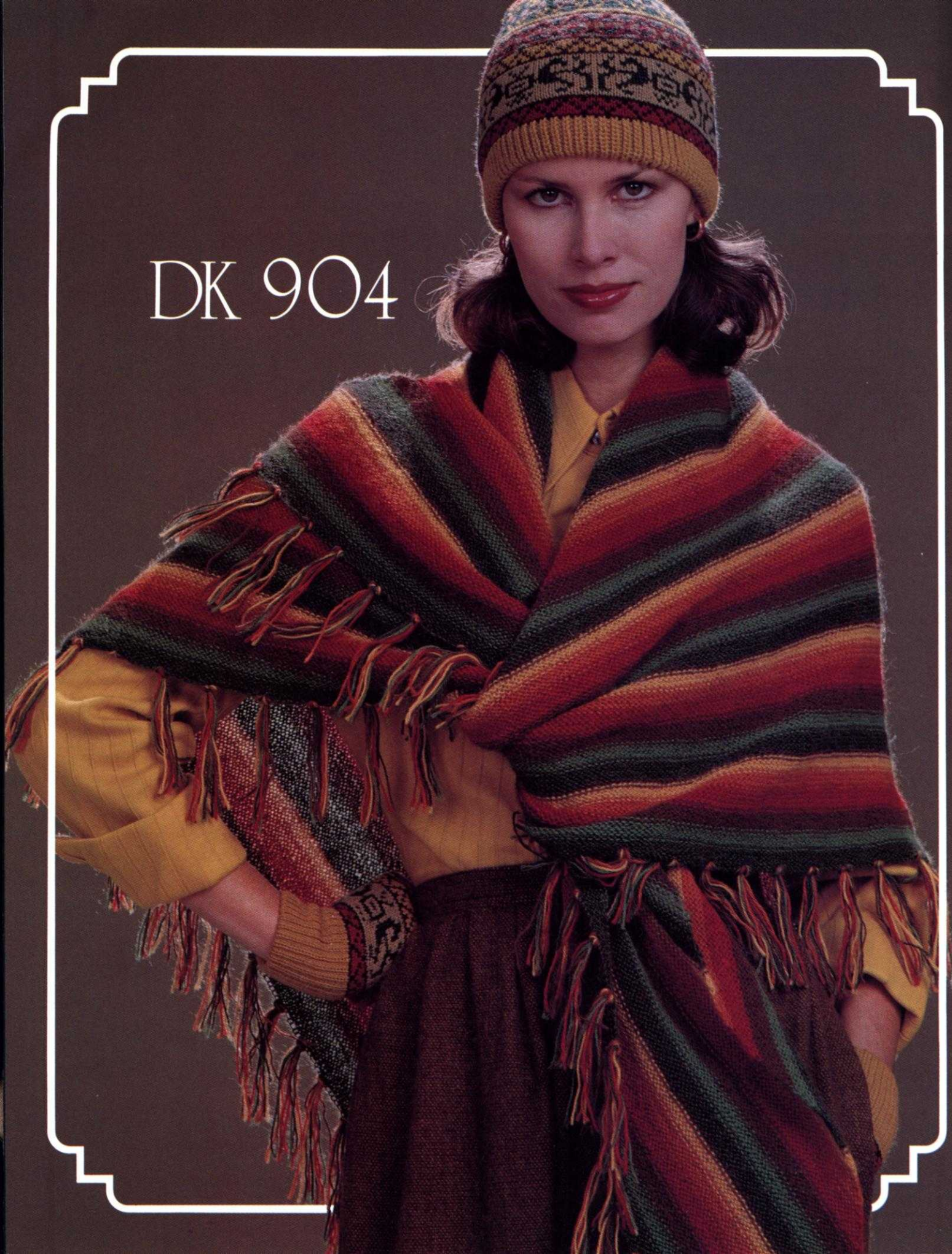

DK 905

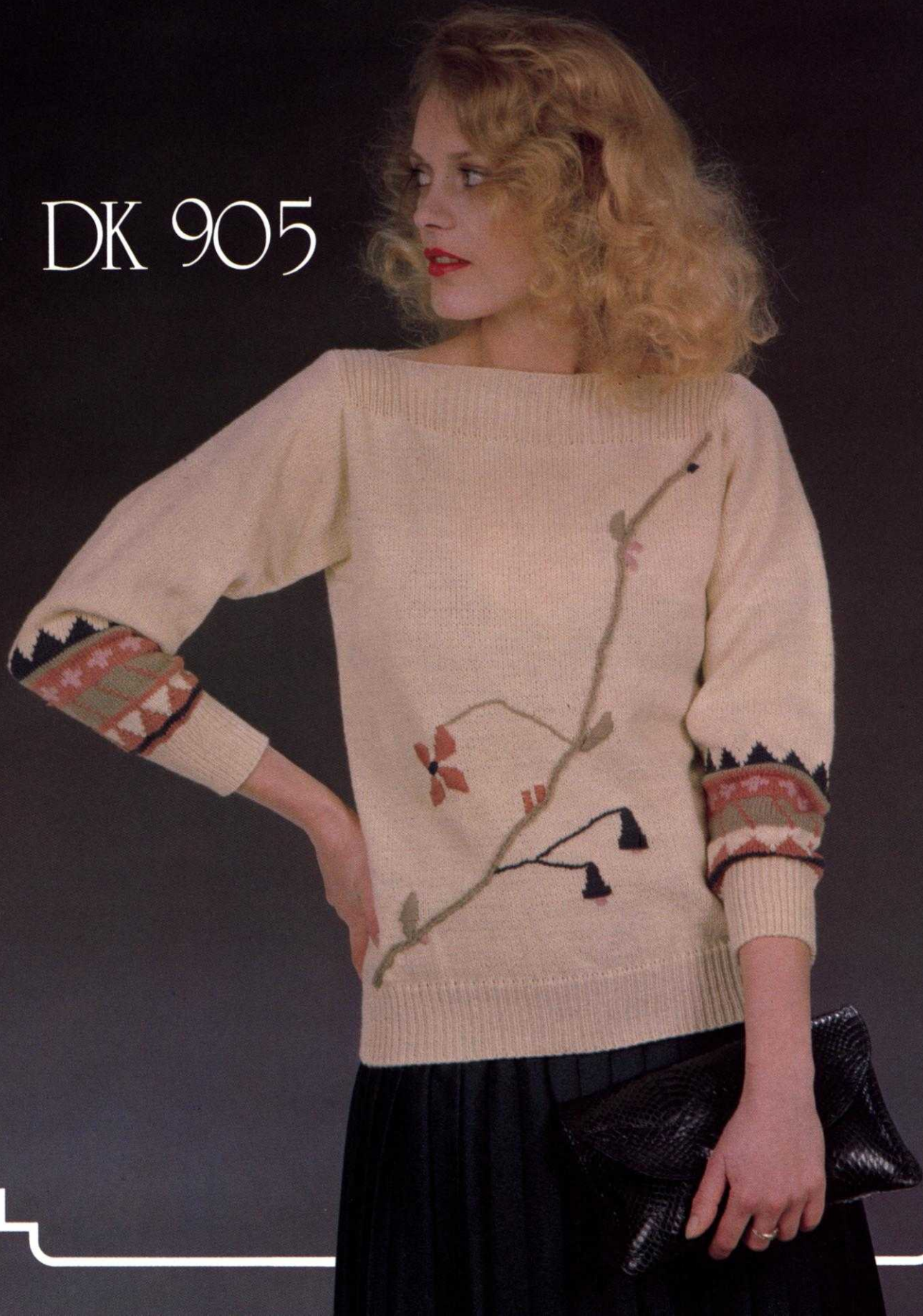

DK 901

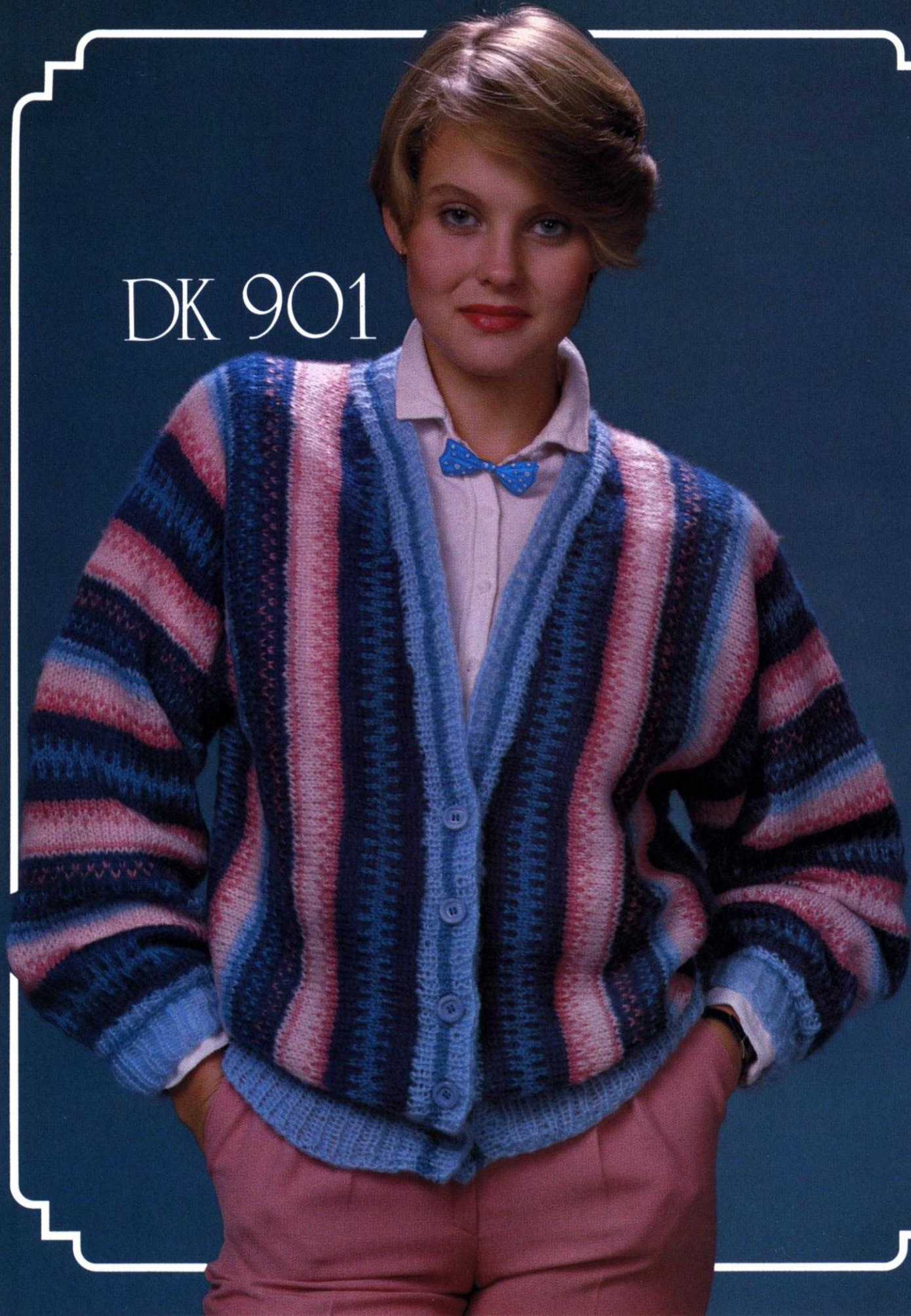

VOLUME 16, NO. 2

knitking

magazine

TABLE OF CONTENTS PAGE NO.

DK 889	Woman's Jacket & Skirt	14
DK 890	Woman's Pullover	15
DK 891	Woman's Blouson	16
DK 892	Woman's Jacket	17
HP 893	Man's Pullover	18
HP 894	Man's Pullover	18
HP 895	Man's Pullover	20
DK 896	Woman's Pullover	21
DK 897	Woman's Vest	22
KK 898	Baby's Suit	23
KK 899	Child's Dress & Vest	25
KK 900	Child's Suit	26
DK 901	Woman's Jacket	28
DK 902	Woman's Pullover	27
HP 903	Man's Pullover	29
DK 904	Woman's Shawl	30
DK 905	Woman's Pullover	31
DK 906	Woman's Pullover 30 &	32
DK 907	Woman's Pullover	32
DK 908	Child's Dress	33
DK 909	Woman's Pullover	34
Gift	Mason Jar Covers	35
Gift	Pillow	36
Gift	Scarf	36

Publisher: KNITKING CORPORATION, 1128 Crenshaw Blvd., Los Angeles, Calif. 90019. Telephone: (213) 938-2079. Published bi-monthly. Subscriptions: USA — \$15.00 annually, single copies \$4.00; Canada — \$18.00; other parts of the world — \$20.00. The entire contents of KNITKING MAGAZINE are copyright and must not be reproduced in any shape or form without the express permission, in writing of the publisher. ©COPYRIGHT 1980 by KNITKING CORPORATION.

editorial

EDITORIAL

During the more than 15 years we have published KNITKING MAGAZINE, we have suffered our share of growing pains. It was not an easy task for a company whose main business is the importation and distribution of knitting machines, to develop, prepare and circulate what is now recognized as the worlds finest English language Knitting Machine Magazine.

Because KNITKING MAGAZINE is a non-profit publication, prepared as a service to knitting machine owners, it has always been important that everybody in our offices donate some time to its preparation, so everybody, executives, sales people, office workers, teachers, bookkeepers and mechanics, etc., is involved to some extent with the preparation of each edition, even if it is just the final envelope stuffing of each issue as it is prepared for mailing.

Our publication is now reaching subscribers in 18 different countries and its popularity has grown so rapidly in Great Britain since its first distribution there by Bedford Sewing and Knitting Machines Ltd., approximately one year ago, that starting with the next issue, we will be printing a special edition for the U.K. market.

We take this opportunity to thank our readers for their enthusiastic response to KNITKING MAGAZINE with a special thanks to those who have taken the time to write directly to us. We look forward to a lengthy, pleasant association with you all.

If you reside in the United Kingdom or Eire, please place your subscriptions direct with BSK Limited, 13 Lime Street, Bedford, MK 40 1LD. We know you will find them a good company to do business with.

















KNITKING YARN CATALOGUE









Because of the International distribution of KNITKING MAGAZINE, we have experienced some problems in the choice of yarns for use in our patterns. The yarns we normally use are not available on an International basis so we have for the past year, been searching out and testing yarns that are available in the majority of countries to which we send KNITKING MAGAZINE. We are close to a decision regarding our selection of yarns for future use but will not be able to prepare a new Catalogue until the final selection is made. We will advise you in a future edition of KNITKING MAGAZINE. In the meantime, we still have stocks of any yarn we are currently using for our garments.















Pattern Symbols

Knitting – Chart Symbols

- () Size Symbols (2nd Size)
- < > 3rd Size
- ① Color Number
-  Cast on
-  Stitch
-  Row
-  Hem
-  Bind off
-  Stockinette stitch – worn on the Knit side.
-  Stockinette stitch – worn on the Purl side.
-  Knit 1, Purl 1 Ribbing
-  Ribbing Pattern – worn on the Knit side.
-  Ribbing Pattern – worn on the Purl side.
-  Closed Dart
-  Open Dart
-  Put on a stitch holder
-  Reverse 1 section
-  On every other needle
-  Number of Rows between Shapings. Make increase (or decrease) FIRST, then knit 4 rows. For example: 3 x 1  means decrease (or increase) 1 st., knit 4 rows; decrease 1 st., knit 4 rows; decrease 1 st., knit 4 rows; decrease 1 st., knit 4 rows. All decreasing (or increasing) without row numbers as shown must be shaped on every 2nd row.

-  Increase
-  Increase 2 sts. With a transfer tool, move the sts. over the left (or right) leaving 2 empty needles at the point of increase. At the increase point, move 1 st. to the left, (or right) so that there is an empty needles on each side of a stitch. On each side of the center stitch, pick up a stitch from the row below and hang it onto the empty needle.
-  3 stitches on 1 needle. The 1st and 3rd stitch in a group of 3 has been hung on the 2nd or center needle.
-  Short Row increase or decrease; for instance on a flared skirt knitted sideways.
-  Pattern Stitch
-  Pattern Stitch – worn on the Knit side.
-  Pattern Stitch – worn on the Purl side.
-  Repeat
 - I = Front
 - II = Back
 - III = Sleeve
 - IV = Skirt Front
 - V = Skirt Back
 - VI = Collar
 - VII = Pocket
 - VIII = Band
 - IX = Belt
 - X = Cuff
 - XI = Pants Front
 - XII = Pants Back

Finishing – Chart Symbols

-  Match numbers on section for assembling.
 -  Ease
 -  Fold Line
 -  Turn to the wrong side and hem.
- ### Stitch Symbols
-  Needles in holding position
 -  Needles back into working position.
 -  Empty needle (leave in working position)
 -  Needle not used (in the out of work position).
 -  Two stitches on 1 needle, either transferred from the right side or the left side, then put into holding position.
 -  Needle holding 2 stitches. Stitch has been transferred from the RIGHT.
 -  Needle holding 2 stitches. Stitch has been transferred from the LEFT.
 -  Center of garment section



General Instructions

HOW TO READ THE CHARTS AND INSTRUCTIONS

There are 3 sizes given for each Pattern in KNITTING MAGAZINE. Above each Chart for the different sizes, you will see that the first and smaller sizes might be shown as 8/10, the second size as (12/14) and the third as [16/18]. Check the measurements at the bustline and hips on the Charts to be certain that you will knit the correct size, remembering these are ACTUAL measurements of the completed section and that there must be a bigger allowance at the bustline and hipline for a Jacket or a Coat than there would be for a fitted dress or a fitted blouse or pullover. The question in your mind should be "How do I want this garment to fit...?"

When you have chosen the size you need, you can follow the Charts as shown. You will notice that where the shapings are the same FOR ALL SIZES, only 1 set of shapings will be shown on the first Chart and if you are knitting the 2nd or 3rd size, you simply follow the shapings as given for the first size. If the shapings are different, this will be shown on the Charts and you should follow them as given.

On the Charts, increases and decreases will be shown as follows

$\begin{matrix} 5x1 \\ \boxed{6} \end{matrix}$ The number in the box means number of ROWS between the shapings, while the 5x1 above the box means - 1 st. 5x... so you will increase or decrease 1 st. every 6th row 5x.

ARMHOLE SHAPINGS - NECK SHAPINGS - SHOULDER SHAPINGS - are made on every 2nd row UNLESS there is a number in a box along side or below the shapings. The rule is... where there is no box with a number, the shaping is made on every 2nd row.

THE PRINTED INSTRUCTIONS

You can follow the printed instructions or use them in combination with the Charts. Where there is any question in the printed instructions, you have the Charts to show you how the section will look.

The 3 sizes, with the different amounts of cast on stitches and the different shapings will look like this...

Cast on 124 (136) [148] sts. You will
Cast on 124 sts. for the first size.
Cast on 136 sts. for the 2nd size.
Cast on 148 sts. for the 3rd size.

The important thing to remember is that you MUST READ AHEAD so that you KNOW what to do for the size you are knitting. Sometimes where the number of stitches are the same but the number of times different, you will find shapings like this... 3 sts. 1x (2x) [3x], 2 sts. 1x (2x) [3x], 1 st. 3x (4x) [5x]. As you see, you MUST read ahead in order to follow the instructions as given for YOUR SIZE. The rows will be different for the different sizes in some cases... Shoulder and Neck shapings usually are worked at the SAME TIME for the back section - so watch for the words AT THE SAME TIME.

HOLDING STITCHES ON THE LEFT SIDE WHILE SHAPING THE RIGHT SIDE

When knitting a section of garment in stockinette stitch, it is easy to hold the stitches on the left side while knitting the right half, but when knitting a Pattern Stitch such as a Norwegian Design, a Holding Position Design, Weaving, etc., you should use the following method. For the NECK SHAPING, we tell you to bind off the center sts., put the needles on the left into holding position and complete the right half first... so with a strand of contrast yarn, knit ALL of the left side stitches manually by hand, pulling each stitch back against the needle bed to the OUT OF WORK position. When the right side is completed, carefully pull the stitches held on contrast, forward into working position and as you do so, undo the contrast yarn, line up the needles (KNITTING AM 3 machine owners, put the stitches under the sinkers) and complete the left half.

If you own a Japanese machine, you may find that when knitting the right half with the left side held in this way, the sinker plate will mark the left side while you are knitting the right half. To prevent this marking, you can tape a piece of paper over the knitting, underneath the sinkers, or if you own a Reversing Bar, you can hang this onto the Sinkers while you are knitting the right half. When hanging the Reversing Bar, be sure the eyes of the bar go BETWEEN the Sinker Posts on the upper part of the bar so that the tips of the bar only - show above the needle bed.

FULL FASHION DECREASING OR INCREASING

For Stockinette stitch, always use the Full Fashion method for increasing or decreasing.

TO DECREASE: Hang the 3rd stitch onto the 2nd stitch then move the stitches in to fill the empty needle.

TO INCREASE: Move the 2 end stitches 1 needle outward, then pick up the 3rd stitch from the row below and hang it onto the empty needle.

FINISHING: Block all sections. For PULLOVERS, JACKETS, and DRESSES: Join front to back at sides and shoulders. Sew sleeves together and set in. Hem lower edge and sleeve edges if needed. For a double neckband or armhole band, sew 1 edge to the inside and 1 to the outside of neck or armhole. For a single ribbed band, sew 1 edge to the outside of neck or armhole edge. For a cardigan or jacket with buttonholes, finish buttonholes and sew on buttons.

PANTS: Join front to back at sides. Sew inside leg seams, then join center front and back. Make hem at waistline and insert elastic. Hem lower edge of pants legs.

THE SAMPLE SWATCH

Before you begin to knit any garment, you will need to knit a sample piece using the yarn you have chosen for your garment, so that you can check the stitch and row gauge which must measure the correct number of stitches and rows in 5 cm (2 inches).

For each Pattern in KNITTING MAGAZINE, we give you 3 tension numbers to work from and if you use the specified yarn for the garment, you should be able to get the correct stitch and row gauge using one of these numbers. Here is a very easy way to make your sample swatch and count the stitches and rows without actually counting, by using our KNITTING Converta Tape.

Supposing the Tension Numbers for the Stitch and Row Gauge are given as 5 to 7. Set the Tension Dial to the first number which is 5. With contrast waste yarn, and using the quick cast on method, cast on 60 stitches and knit 10 rows. Change to garment yarn and turn the Row Counter to 0. Knit 30 rows. Counting from each end, knit the 10th stitch on each side by hand with a small piece of contrast yarn. Leave the needles in working position and knit 30 rows (Row 60), then knit 4 rows with contrast waste yarn. Turn the Row Counter to 0 and the Tension Dial to 6 and with garment yarn, knit 30 rows. Mark the 10th stitch on each side as you did before, knit 30 rows, then 4 rows with contrast waste yarn. Turn the Row Counter to 0 and with Tension 7, repeat the above once more, ending with 10 rows of contrast waste yarn. Remove the work from the machine by passing the Slide across the needles without yarn (sometimes called 'dropping'). Pull and stretch the sample piece both lengthwise and diagonally from corner to corner, then lengthwise again. Do not count the stitches and rows immediately, but allow the sample to rest for several hours or even over night. This will allow the stitches and rows to return to their basic form.

When your sample has rested and you are ready to count the stitches and rows, the KNITTING CONVERTA TAPE will do the counting for you without any counting on your part. Use the Tape as follows:

Measure the stitches with the TAPE, BETWEEN the 40 stitches marked with contrast waste yarn. Push the SLIDE so that the LEFT EDGE lines up to this exact measurement. Now look down along side the SLIDE and find the number 40 on the TAPE. The number directly opposite on the SLIDE will be your Stitch Gauge to 5 cm (2"). To find the number of rows in 5 cm (2"), place the TAPE to measure over the 60 rows, push the SLIDE to this number with the left edge lined up, the look for the number 60 on the TAPE and directly opposite this will be the number of rows to 5 cm (2")

If you do not own a KNITTING CONVERTA TAPE, you must mark a 5 cm (2 inch) square in the center of the knitting, then count the number of stitches and rows within the square.

DK 889

WOMAN'S JACKET & SKIRT

SIZES: 10 (12) [14]

YARN: Vienna

GRAMS:

color 1	900	900	950
color 2	100	150	150
color 3	50	100	100
color 4	50	100	100

TENSION: Pat: 4-5
3-4

GAUGE:

Pat: 16 1/2 sts. 36 rows = 5 cm (2")

Stock: 16 1/2 sts. 22 rows = 5 cm (2")

The skirt is Stockinette stitch and is knitted from the waist down. The Jacket is a Norwegian Design using both the Knitter and Ribber and the 830 Color Changer.

FINISHING: Sew side seams, shoulder and sleeve seams then sew in sleeves. Sew facings to Jacket then sew on Collar.

NOTE: You must use both the Knitter and Ribber with the 830 Color Changer. The cast-on sts. and all shapings must be on BOTH BEDS although the sts. are only given for one bed.

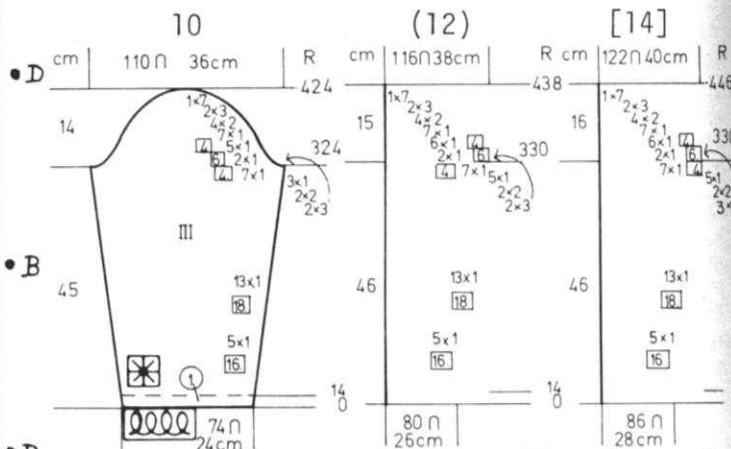
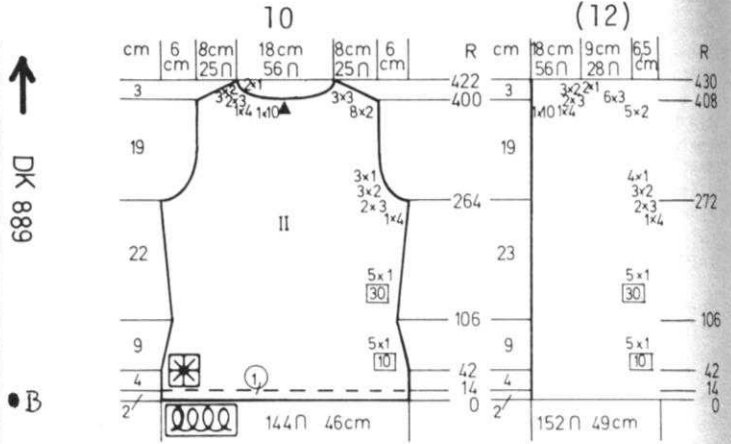
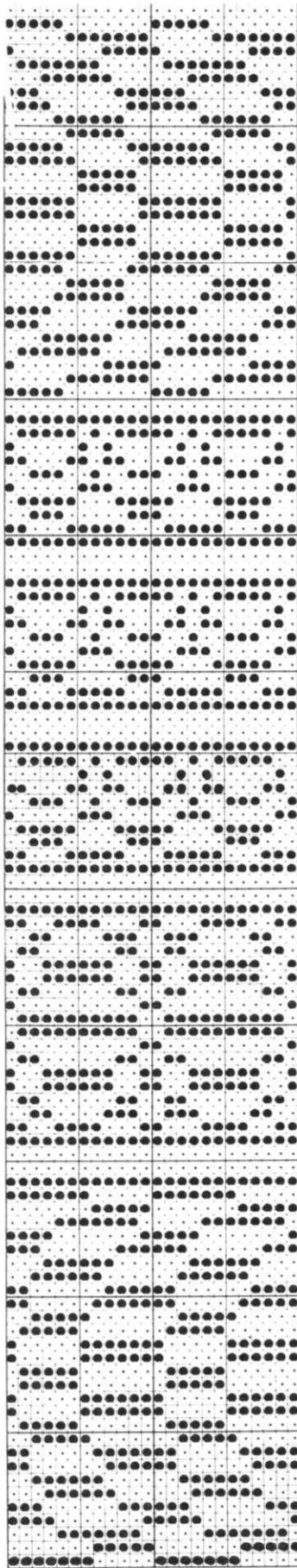
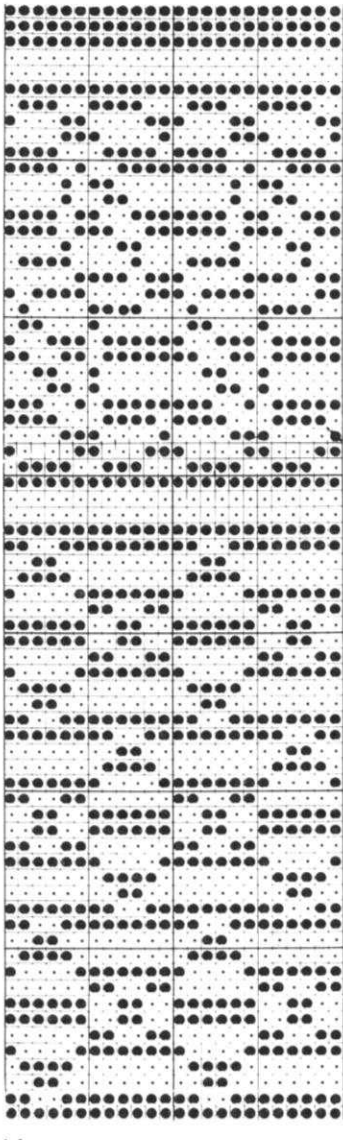

SLEEVES: III

Cast on 74 (80) [86] sts. with color 1 and work 14 rows then continue in Pattern.

ON EACH SIDE, after Row 14, increase 1 st. every 16th row 5x, every 2nd row 1 st. 7x, 2 sts. 4x, every 18th row 13x for all sizes.

After Row 324 (330) [330], SHAPE CAP: ON EACH SIDE, bind off 3 sts. 2x, 2 sts. 2x, 1 st. 3x,

1 st. every 4th row 7x, every 6th row 2x, every 4th row 5x, then 1 st. every 2nd row 7x, 2 sts. 4x, 3 sts. 2x, 7 sts. 1x.
(3 sts. 2x, 2 sts. 2x, 1 st. 5x, 1 st. every 4th row 7x, every 6th row 2x, every 4th row 6x, then 1 st. every 2nd row 7x, 2 sts. 4x, 3 sts. 2x, 7 sts. 1x].

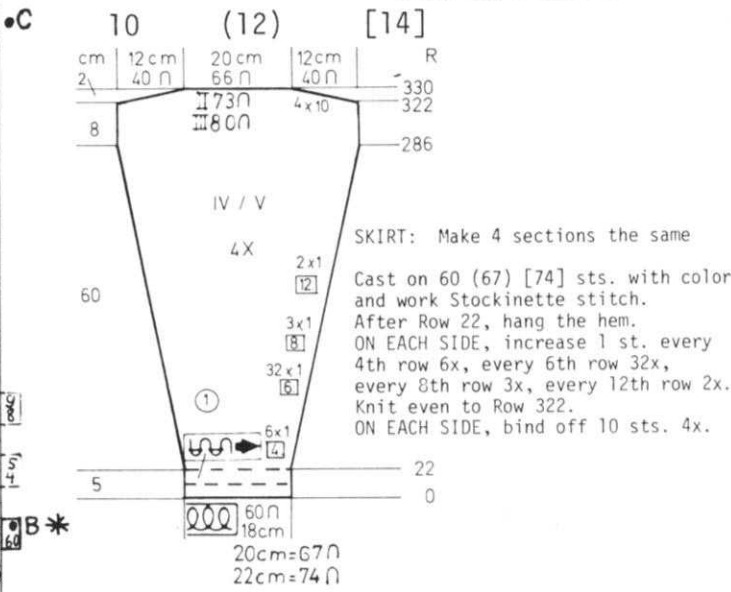

SKIRT: Make 4 sections the same

Cast on 60 (67) [74] sts. with color 1 and work Stockinette stitch. After Row 22, hang the hem. ON EACH SIDE, increase 1 st. every 4th row 6x, every 6th row 32x, every 8th row 3x, every 12th row 2x. Knit even to Row 322. ON EACH SIDE, bind off 10 sts. 4x.

BACK: II

Cast on 144 (152) [168] sts. with color 1 and work 14 rows, then continue in Pattern.
 After Row 42 (42) [50], ON EACH SIDE, decrease 1 st. every 10th row 5x for all sizes.
 After Row 106 (106) [114], ON EACH SIDE, increase 1 st. every 30th row 5x for all sizes.
 After Row 264 (272) [280], SHAPE ARMHOLE: ON EACH SIDE, bind off 4 sts. 1x, 3 sts. 2x, 2 sts. 3x, 1 st. 3x.
 (4 sts. 1x, 3 sts. 2x, 2 sts. 3x, 1 st. 4x).
 [5 sts. 1x, 3 sts. 3x, 2 sts. 3x, 1 st. 2x].
 After Row 400 (408) [424], put half the sts. on the left into holding position and complete the right side first.

* SHAPE SHOULDER AND NECK AT THE SAME TIME.

FOR SHOULDER, bind off 2 sts. 8x, 3 sts. 3x.
 (2 sts. 5x, 3 sts. 6x).
 [2 sts. 2x, 3 sts. 9x].
 FOR NECK, bind off 10 sts. 1x, 4 sts. 1x, 3 sts. 2x, 2 sts. 3x, 1 st. 2x.
 (Same as first size).
 [12 sts. 1x, 5 sts. 1x, 3 sts. 2x, 2 sts. 3x, 1 st. 2x].
 Bring the needles on the left into working position, knit 1 row to the left side, turn the Row Counter back to 400 (408) [424] and complete the left half. Follow the instructions from *.

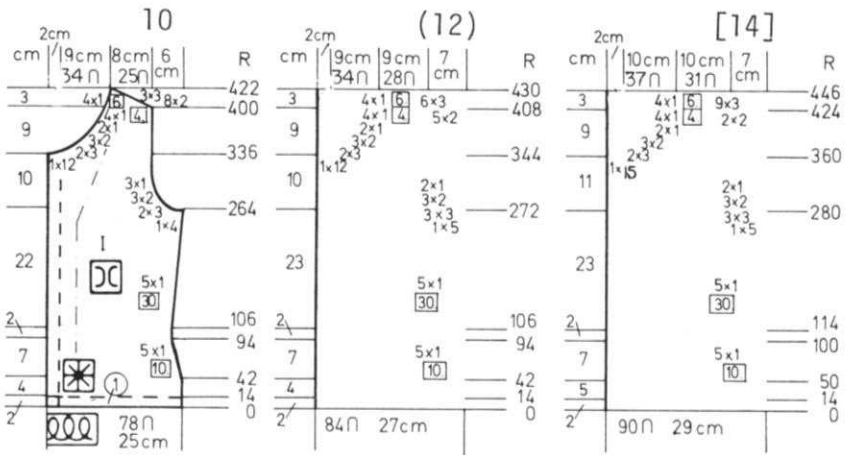

FRONT: I Make 1, reverse 1.

Cast on 78 (84) [90] sts. with color 1 and work 14 rows, then continue in Pattern.
 After Row 42 (42) [50], ON THE RIGHT (left for 2nd section) decrease 1 st. every 10th row 5x.
 After Row 106 (106) [114], ON THE RIGHT (left for 2nd section), increase 1 st. every 30th row 5x.
 After Row 264 (272) [280], SHAPE ARMHOLE same as the back.

After Row 335 (343) [359], SHAPE NECK: Bind off 12 sts. 1x, 3 sts. 2x, 2 sts. 3x, 1 st. 2x, 1 st. every 4th row 4x, then every 6th row 4x. (Same as first size).
 [15 sts. 1x, 3 sts. 2x, 2 sts. 3x, 1 st. 2x, 1 st. every 4th row 4x then every 6th row 4x].
 After Row 400 (408) [424], SHAPE SHOULDER same as the back.

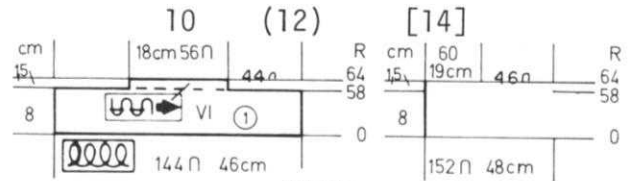

COLLAR: VI

FRONT FACINGS: Make 1, reverse 1.

Cast on 20 sts. with color 1 (20 sts. on each bed).
 Knit to Row 224 (230) [238].
 ON THE RIGHT (left for 2nd section) increase 1 st. every 10th row 3x (3x) [every 6th row 4x] then every 8th row 21x (21x) [23x].
 After Row 335 (343) [359], SHAPE NECK: Bind off 12 (12) [15] sts. then bind off for all sizes 3 sts. 2x, 2 sts. 3x, 1 st. 2x, then every 4th row 1 st. 4x, every 6th row 1 st. 4x.
 After Row 422 (430) [446], bind off the remaining sts.



COLLAR: VI

Cast on 114 sts. and work 54 rows K2, P2 Ribbing. Bind off.

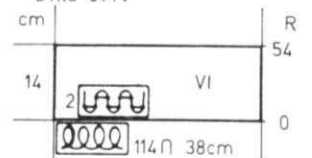

BACK: II

Cast on 144 (150) sts. and work 26 rows K2, P2 Ribbing. Transfer the main machine needles to the Ribber. Continue in Pattern.
 After Row 134 (138), mark each side for setting in sleeves.
 Knit to Row 210 (214).
 SHAPE SHOULDER: ON EACH SIDE, bind off 12 sts. 4x.
 (12 sts. 3x, 15 sts. 1x).
 After Row 218 (222), bind off the remaining sts.

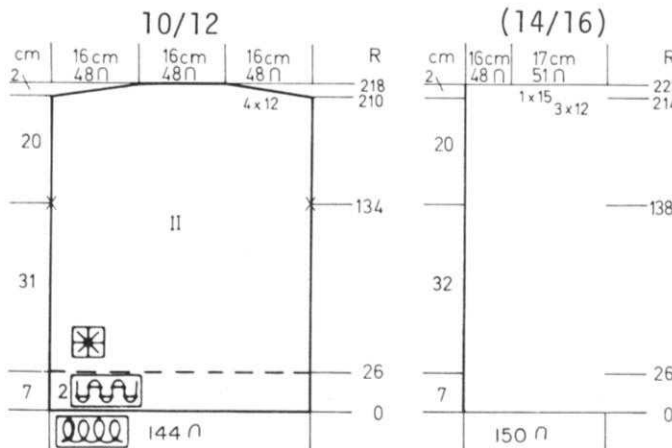

[14]

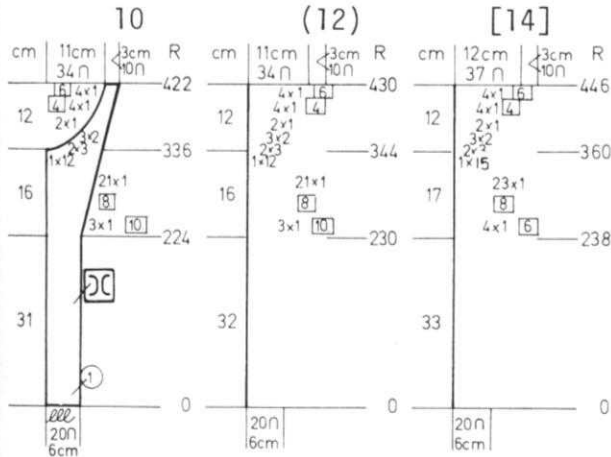
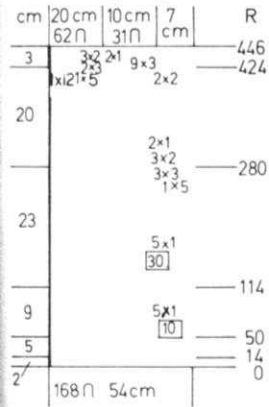

DK 890

WOMAN'S PULLOVER

SIZES: 10/12 (14/16)
 YARN: Vienna
 GRAMS: 400 450
 TENSION: 6 to 8
 GAUGE: 15 sts. 15 rows = 5 cm (2")

Pattern - Main machine and Ribber.
 Punch your own Card and be sure to read note below. Bands and collar are K2, P2 or K1, P1 Ribbing.

FINISHING: See General Instructions.

DK 890

IMPORTANT NOTE: To use the Punch Card - After Ribbing, transfer main machine stitches to the Ribber. (All needles on BOTH beds in working position) PH lever on "H". Needles on main machine in "B" position but all EMPTY. Both "Part" Buttons pushed in. With carriage on the left, set KC, then move carriage to the right to set the needles. Connect to Ribber Carriage and set Card on "G0". Leave "Part" buttons pushed in throughout. *Knit 6 rows, transfer the end sts. to the middle st. on every 3 needle section of the main machine, leaving the empty needles in "B" position*. REPEAT from * to * for Pattern.

When shaping, remember that you must always increase or decrease or bind off the same amount of sts. on BOTH BEDS although the shaping is given in the instructions and on the Charts for one bed only.

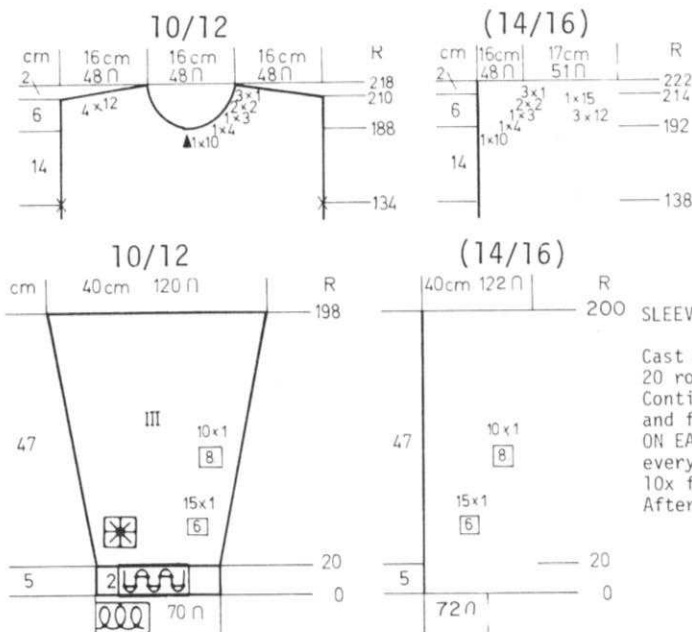

FRONT: I
Work the front the same as the back to Row 188 (192). Put half the sts. on the left into holding position and complete the right side first. *SHAPE NECK: ON NECK SIDE, bind off for both sizes 10 sts. 1x, 4 sts. 1x, 3 sts. 1x, 2 sts. 2x, 1 st. 3x. After Row 210 (214), SHAPE SHOULDER same as the back.

SLEEVES: III
Cast on 70 (72) sts. and work 20 rows K2, P2 Ribbing. Continue in Pattern same as back and front. ON EACH SIDE, increase 1 st. every 6th row 15x, every 8th row 10x for both sizes. After Row 198 (200), bind off.

DK 891

WOMAN'S BLOUSON

SIZES: 12 to 16
YARN: Fortissima
GRAMS: 600
GAUGE: Pat. A = 6 to 7
Pat. B = 5 to 6
GAUGE: Pat A = 15 sts. 18 rows = 5 cm
Pat B = 15 sts. 21 rows = 5 cm

There are 3 different Patterns used plus K2, P2 Ribbing for the Bands. Pattern A is formed by following the explanation given with the written instructions. Pattern B is an eyelet design and you must punch your own card.

Pattern C is Garter stitch and is made by turning the work EVERY ROW using the Reversing Bar.

FINISHING: See General Instructions. Make cord and pull through above the waistband.

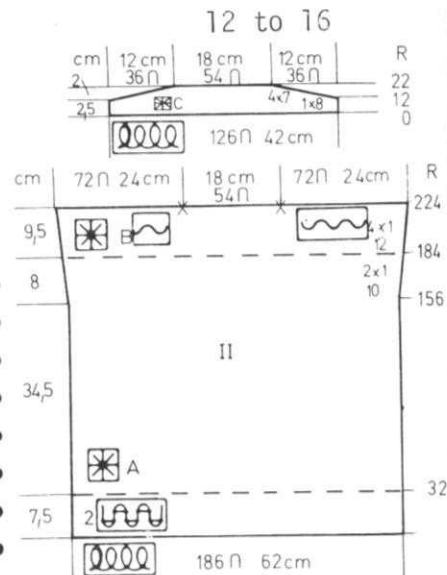
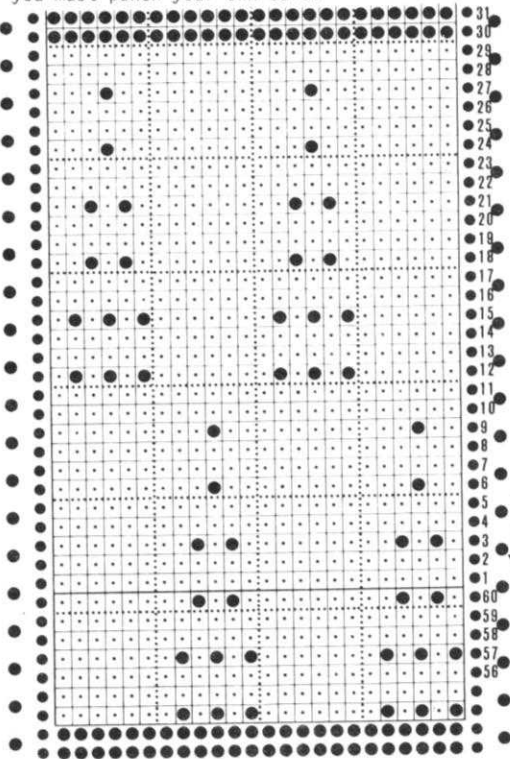

PATTERN A
*Knit 10 rows. Bring all the needles forward so that the stitches go behind the latches. Make sure all the needle latches remain open. Place the yarn BY HAND, across the open latches and KNIT EACH STITCH BY HAND, pulling the stitch ALL THE WAY BACK AGAINST THE BACK NEEDLE RAIL ("A" position). The stitches are really knitted only HALF WAY. Leave the stitches in this position until you have them all knitted and lined up. Now, carefully pull the knitting forward into knitting position (do not allow the sts. to go behind the latches - just bring the needles to the front edge of machine). Be sure to hang weights on the knitting. REPEAT FROM * FOR PATTERN.

FRONT BANDS: Make 2. On one side of split, pick up 10 sts. and work garter stitch for as long as you need. Repeat for other side. Sew these bands in place.

NECKBAND: Cast on 10 sts. and work in garter stitch long enough to go around neckline. Sew band in place.

12 to 16

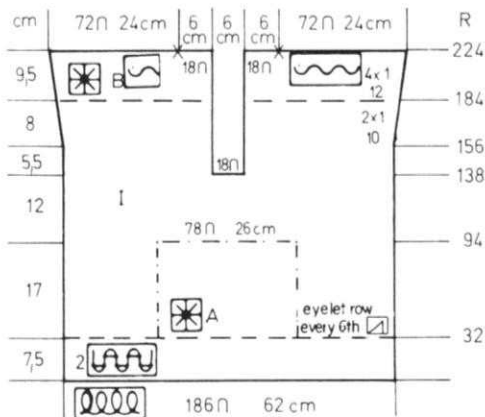
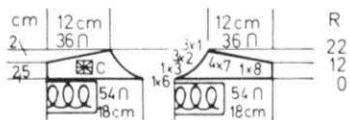

POCKET BANDS:

Pick up 50 sts. along pocket edge and work 8 rows Ribbing. Bind off.

BACK YOKE:

With knit side facing you, hang the center 54 sts. of the back onto the machine, then ON EACH SIDE, hang 2 sts. on each needle (126 sts.). *Knit 1 row, reverse the knitting*. REPEAT FROM * to * for Pattern C, BUT AT THE SAME TIME, ON EACH SIDE, after Row 12, SHAPE SHOULDER: Bind off 8 sts. 1x, 7 sts. 4x. After Row 22, bind off the remaining sts.

BACK: II

Cast on 186 sts. and work 32 rows Ribbing. Transfer the Ribber sts. to main machine, knit 1 row. Transfer every 6th st. to adjacent needle (eyelets for cord), leave empty needles in working position. Knit 1 row. Continue in Pattern A. After Row 156, ON EACH SIDE, increase 1 st. every 10th row 2x. After Row 184, continue in Pattern B AND AT THE SAME TIME, ON EACH SIDE, increase 1 st. every 12th row 4x. After Row 224, remove the sts. onto contrast waste yarn after marking the center 54 sts. for neck.

FRONT YOKE:

Bring 54 needles into working position. Hang the sts. (with knit side facing you) of 1 front onto machine beginning with front edge, hang the first 18 sts. then double up on the next 36 sts. Work in Pattern C, reversing the knitting ON EVERY ROW same as you did for the back yoke and AT THE SAME TIME, ON NECK SIDE, bind off 6 sts. 1x, 3 sts. 1x, 2 sts. 3x, 1 st. 3x and AT THE SAME TIME after Row 12, SHAPE SHOULDER same as the back. REPEAT the instructions for 2nd half.

FRONT: I

Cast on 186 sts. and work 32 rows Ribbing. Transfer the ribber sts. to main machine and work the eyelet same as you did for the back. Leave the center 78 sts. in working position and put the sts. ON EACH SIDE into holding position. Work in Pattern A over the center sts. to Row 94 then remove these sts. onto contrast waste yarn. Cast on over these same needles, Put Counter at 34 and work in pattern to Row 94. Put these sts. into holding position. Bring 1 side into working position, Counter at 34 and work in Pattern to Row 94. Repeat for other side. Bring all needles into working position, hang the sts. held on waste yarn onto the center needles. Counter at 94 and continue in Pattern A to Row 138. Bind off the center 18 sts. and work 1 side at a time. *After Row 156, ON SIDE EDGE, increase 1 st. every 10th row 2x. After Row 184, Continue in Pattern B and AT THE SAME TIME, ON SIDE EDGE increase 1 st. every 12th row 4x. After Row 224, remove onto contrast waste yarn but mark the 18th st. for front neck. Put Counter back to 138 and work the left half. Knit to Row 156 then follow the instructions from *.

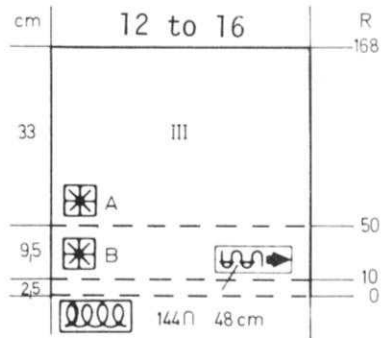

SLEEVES: III

With contrast waste yarn, cast on 144 sts. After knitting 8 to 10 rows, change to garment yarn and put counter at 0. Work 10 rows Stockinette stitch then continue in Pattern B to Row 50. Continue in Pattern A to Row 168. Bind off.

WRISTBANDS: Make 2.

Hang the open sts. of the sleeve back onto the machine, decreasing to 72 sts. Work 34 rows Ribbing then bind off.



After Row 256 (260) [264] SHAPE SHOULDER and watch for neck shaping. FOR SHOULDER: ON EACH SIDE, bind off 4 sts. 5x, 3 sts. 2x (4 sts. 7x) [4 sts. 5x, 5 sts. 2x] AT THE SAME TIME, after Row 260 (264) [268], bind off the center 20 sts., put the needles on the left into holding position and complete the right side first. *ON NECK SIDE, bind off 3 sts. 2x. (3 sts. 2x). [3 sts. 2x, 2 sts. 1x]. Bring the needles on the left into working position, knit 1 row to the left side, turn the Row Counter back to 260 (264) [268] and complete the left half. Follow the instructions from * and don't forget to complete the shoulder shaping.

BACK: II

Cast on 106 (114) [122] sts. and work in Pattern. Knit to Row 168 (172) [172]. SHAPE ARMHOLE: ON EACH SIDE, bind off 4 sts. 1x, 3 sts. 1x, 2 sts. 1x, 1 st. 2x. (4 sts. 1x, 3 sts. 1x, 2 sts. 2x, 1 st. 2x). [4 sts. 1x, 3 sts. 1x, 2 sts. 2x, 1 st. 3x].



DK 892

WOMAN'S JACKET

SIZES: 10/12 (14) [16/18]
YARN: Boucle
GRAMS: 800 850 900
TENSION: 10
GAUGE: 10 1/2 sts. 20 rows = 5 cm (2")

A Slip Stitch Pattern. Punch your own card or KNITTING 840 owners, use Card No. 26. Push in BOTH PART BUTTONS for Pattern. Worn on the Purl side.

FINISHING: See General Instructions. Sew Pocket in place. Work 1 row single crochet, 1 row reverse single crochet around jacket edges. Sew in shoulder pads if you wish. (See Picture)

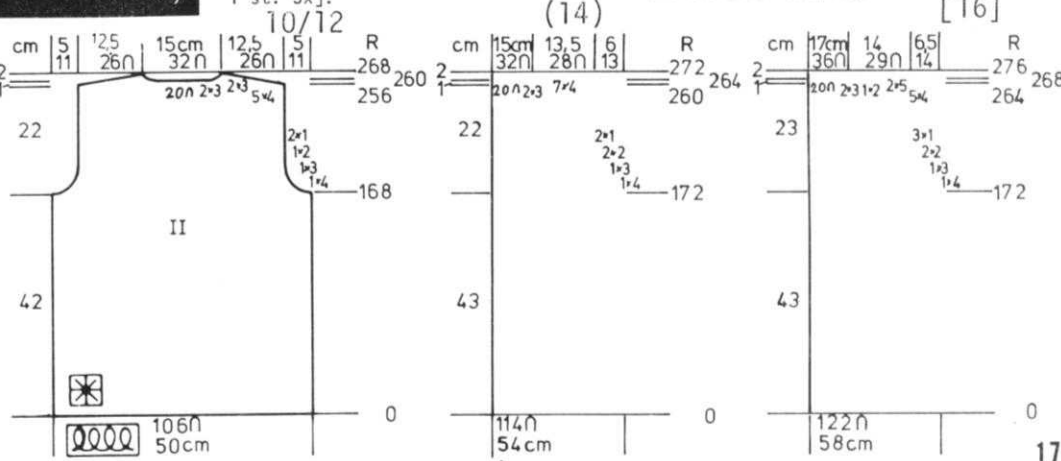

DK 892

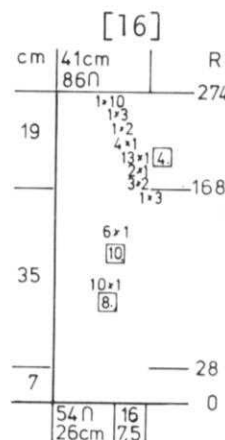
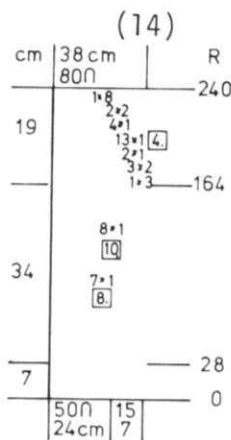
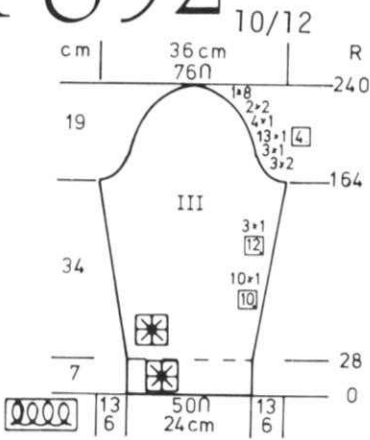

SLEEVES: III

Cast on 50 (50) [54] sts. and work in Pattern.
 After Row 28, ON EACH SIDE, increase 1 st. every 10th row 10x, every 12th row 3x.
 (every 8th row 7x, every 10th row 8x).
 [every 8th row 10x, every 10th row 6x].
 After Row 164 (164) [168], SHAPE CAP: ON EACH SIDE, bind off 2 sts. 3x, 1 st. 3x, 1 st. every 4th row 13x, 1 st. every 2nd row 4x, 2 sts. 2x, 8 sts. 1x. (3 sts. 1x, 2 sts. 3x, 1 st. 2x, 1 st. every 4th row 13x, 1 st. every 2nd row 4x, 2 sts. 2x, 8 sts. 1x). [3 sts. 1x, 2 sts. 3x, 1 st. 2x, then 1 st. every 4th row 13x, 1 st. every 2nd row 4x, 2 sts. 1x, 3 sts. 1x, 10 sts. 1x.

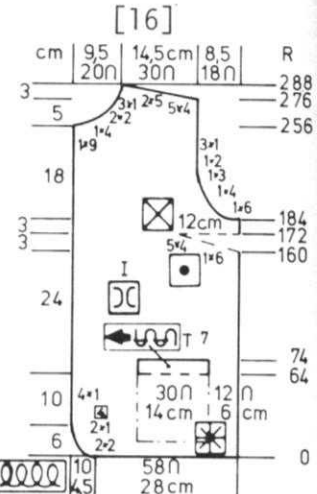
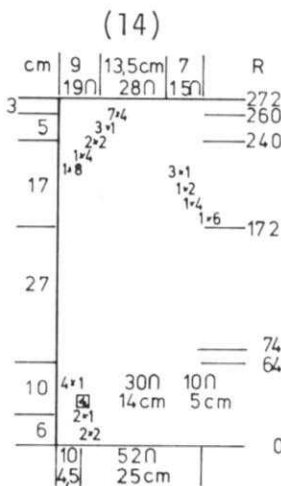
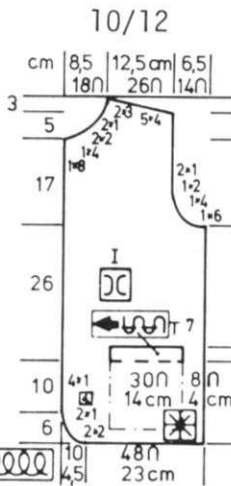
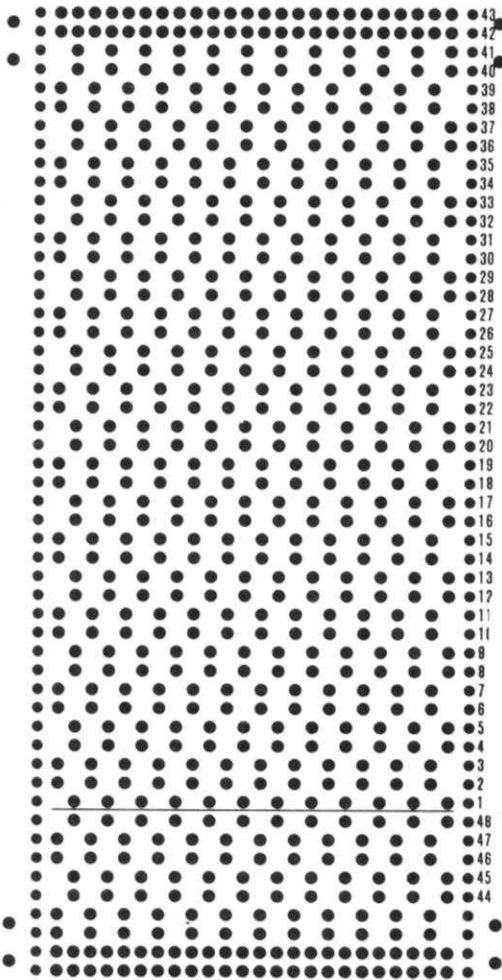

LEFT FRONT: I Reverse 2nd section.

MAKE POCKET LINING FIRST.
 Cast on 48 (52) [58] sts. and work in Pattern.
 ON THE LEFT (right for 2nd section) on every 2nd row, cast on 2 sts. 2x, 1 st. 2x, then 1 st. every 4th row 4x.
 Knit even to Row 64.
 Work the pocket. Put into holding position 8 (10) [12] sts. on the right (left), leave the next 30 sts. in work then put the remaining sts. into holding position. Work over the 30 sts. in work and knit 10 rows and remove on waste yarn. Hang the pocket lining sts. onto these empty needles and continue over all needles.
 Knit to Row 168 (172) [160].
 [FOR THE 3rd SIZE ONLY, work BUST DART. After Row 161, put into holding position opposite carriage, 6 sts. 1x, 4 sts. 5x. Bring all the needles back into working position and knit to Row 184].
 SHAPE ARMHOLE: Bind off 6 sts. 1x, 4 sts. 1x, 2 sts. 1x, 1 st. 2x. (6 sts. 1x, 4 sts. 1x, 2 sts. 1x, 1 st. 3x). [6 sts. 1x, 4 sts. 1x, 3 sts. 1x, 2 sts. 1x, 1 st. 3x].
 After Row 235 (239) [255] SHAPE NECK: Bind off 8 (8) [9] sts. 1x, 4 sts. 1x, 2 sts. 2x, 1 st. 2x([3x]). and after Row 256 (260) [276], SHAPE SHOULDER same as the back.

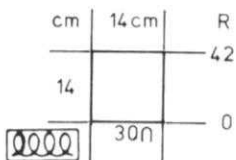

POCKET LINING:

Cast on 30 sts. and work 42 Rows in Pattern. Remove onto contrast waste yarn.

HP 893

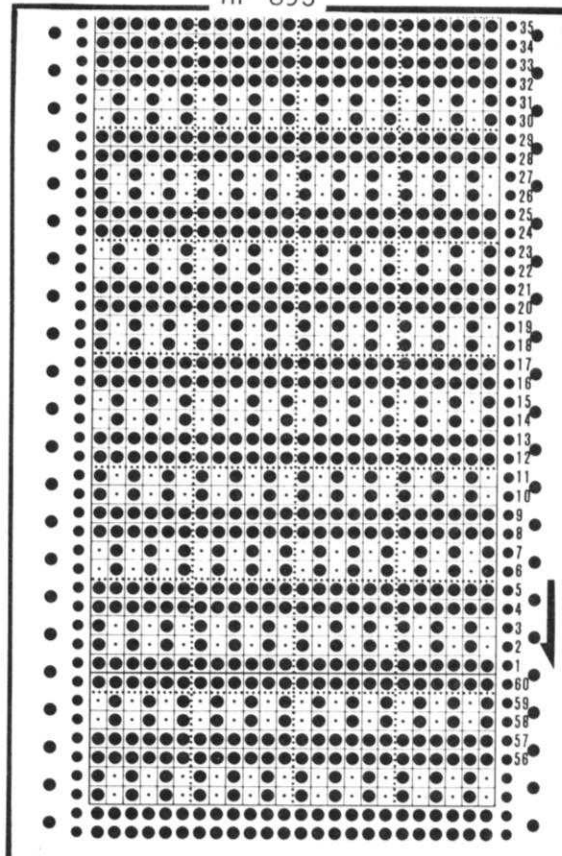

HP 893

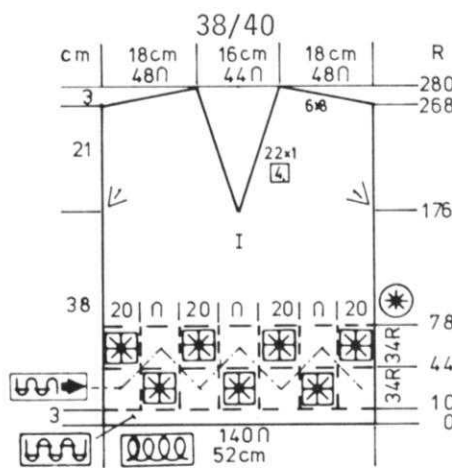

FRONT: I

Work the front the same as the back to Row 176. Mark each side with contrast waste yarn for setting in sleeves then divide in the center. Put half the sts. on the left into holding position and complete the right side first.

*ON NECK SIDE, decrease 1 st. every 4th row 22x and after Row 268, SHAPE SHOULDER same as the back.

Bring the needles on the left into working position, knit 1 row in Pattern to the left side, turn the Row Counter back to 176 and complete the left half. Follow the instructions from *.

NECKBAND:

Cast on 200 sts. and work 10 rows Ribbing. Remove onto contrast waste yarn.



BACK: II

Cast on 140 sts. and work 10 Rows Ribbing. Set into Pattern. (See Note). Continue in Pattern.

After Row 176, mark each side for setting in sleeves. Knit to Row 268.

SHAPE SHOULDER and watch for NECK SHAPING.

FOR SHOULDER, bind off 8 sts. 6x AND AT THE SAME TIME, after Row 276, SHAPE NECK: Put half the sts. on the left into holding position and complete the right side first.

*Bind off 20 sts. for neck then on neck side, bind off 2 sts. 1x. Bring the needles on the left into working position, knit 1 row in Pattern to the left side, turn the Row Counter back to 276 and complete the left half. Follow the instructions from * and don't forget to complete the shoulder shaping.

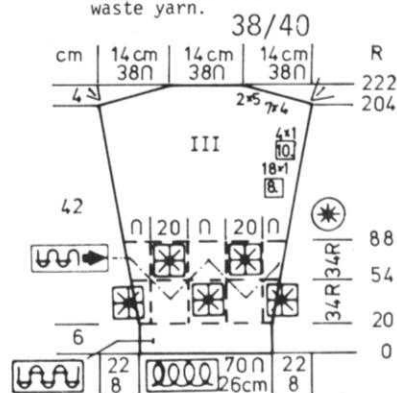

SLEEVES:

Cast on 70 sts. and work 20 rows Ribbing. Continue in Pattern and AT THE SAME TIME, ON EACH SIDE, increase 1 st. every 8th row 18x, every 10th row 4x. After Row 204, ON EACH SIDE, bind off 4 sts. 7x, 5 sts. 2x. After Row 222, bind off the remaining sts.

MAN'S PULLOVER

SIZE: 38/40
YARN: Fortissima
GRAMS: 550
TENSION: PAT: 10/7
RIB: 7/7

GAUGE: 13 1/2 sts. 22 rows = 5 cm

Use the Main Machine and Ribber for knitting this pullover. A Punch Card is used for the main machine. Follow the instructions for the needle set-up and punch your own card. Bands are K1, P1 Ribbing.

FINISHING: See General Instructions.

NOTE: - NEEDLES ON BOTH BEDS are used for this pattern. The needle set-up is 20 sts. on the Main Machine and 20 sts. on the Ribber. After every 34 rows, reverse the sts. - transfer the Ribber sts. to main machine and the main machine sts. to the Ribber.

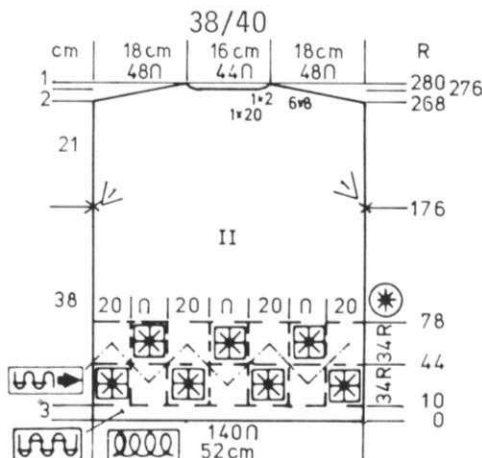

HP 894

MAN'S PULLOVER

SIZES: 38 (40)
YARN: Fortissima
GRAMS: color 1 500 550
color 2 50 50
TENSION: 7 to 9

GAUGE: Stock: 11 sts. 15 1/2 rows = 5 cm (2")
Pat: 11 sts. 18 rows = 5 cm (2")

Pattern: Using Main Machine and Ribber. Bands are K2, P2 Ribbing. Color stripes as shown on the Charts.

FINISHING: See General Instructions.

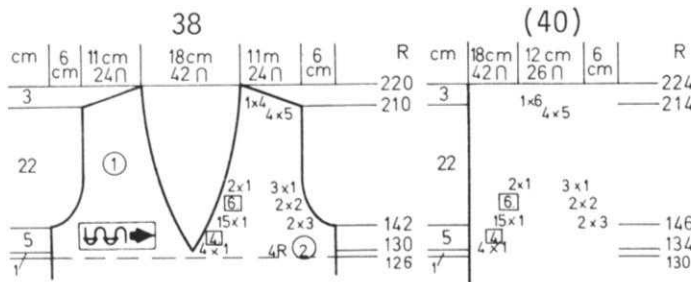

FRONT:

Work the front the same as the back to Row 130 (134). Divide in the center. Put the left half into holding position and complete the right side first.

*ON NECK SIDE, decrease 1 st. every 4th row 4x, every 2nd row 15x, then every 6th row 2x for both sizes BUT AT THE SAME TIME, after Row 142 (146) SHAPE ARMHOLE same as the back. After Row 210 (214), SHAPE SHOULDER same as the back.

Bring the needles on the left into working position, knit 1 row in pattern to the left side, turn the Row Counter back to 130 (134) and complete the left half. Follow the instructions from *.



HP 894

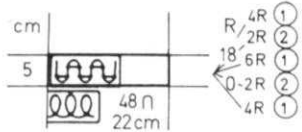

CUFFS:

Cast on 48 sts. with color 1 and work 18 rows Ribbing with color stripes as shown on the Chart. After Row 48, transfer the sts. to main machine and hang the sleeve sts. to it and bind off.

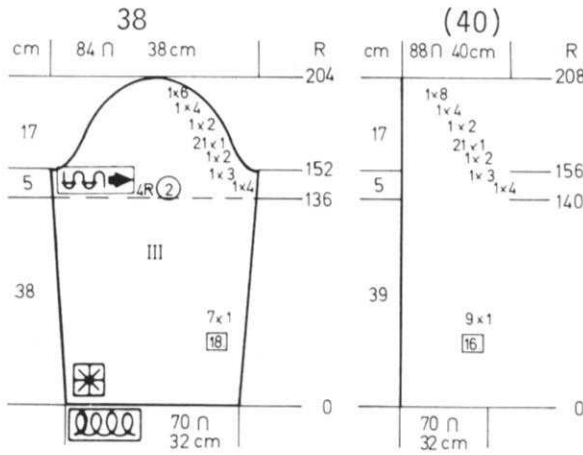

SLEEVES: III

Cast on 70 (70) sts. with color 1 and work in Pattern. ON EACH SIDE, increase 1 st. every 18th row 7x (every 16th 9x). After Row 136 (140), continue in Stockinette stitch. Knit 4 rows Color 2 then knit to Row 152 (156).
SHAPE CAP: ON EACH SIDE, bind off
 4 sts. 1x, 3 sts. 1x, 2 sts. 1x, 1 st. 21x, 2 sts. 1x, 4 sts. 1x, 6 (8) sts. 1x.

NOTE: Follow the Line Drawing for setting the needles and stitches on the main machine and Ribber.
 III = Main Machine
 --- = Ribber
 After Row 6, transfer all sts. to the Ribber then Knit Row 7 and 8. After Row 17, begin from Row 1 again.

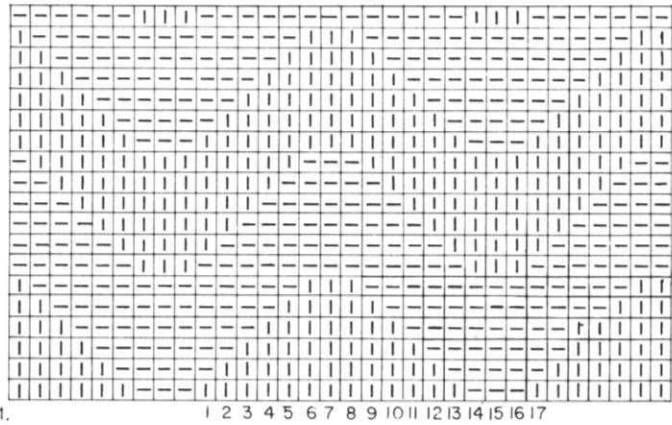

M.

HP 895

MAN'S PULLOVER

SIZES: 36 (38)
YARN: Fortissima
GRAMS: 600 650
TENSION: 6 to 8
GAUGE: 13 sts. 21 rows = 5 cm (2")

Main machine with Ribber according to Line Drawing. Bands are K2, P2 Ribbing.

FINISHING: See General Instructions.



COLLAR:

Cast on 164 sts. and work 60 Rows Ribbing. Transfer to the main bed. Sew Shoulder seams then pick up the sts. along neck edge and hang onto machine and bind off together.

FRONT BANDS: Make 2.

Cast on 90 (94) sts. and work 16 rows K1, P1 Ribbing. Remove onto contrast waste yarn. Weave open sts. to front edges.

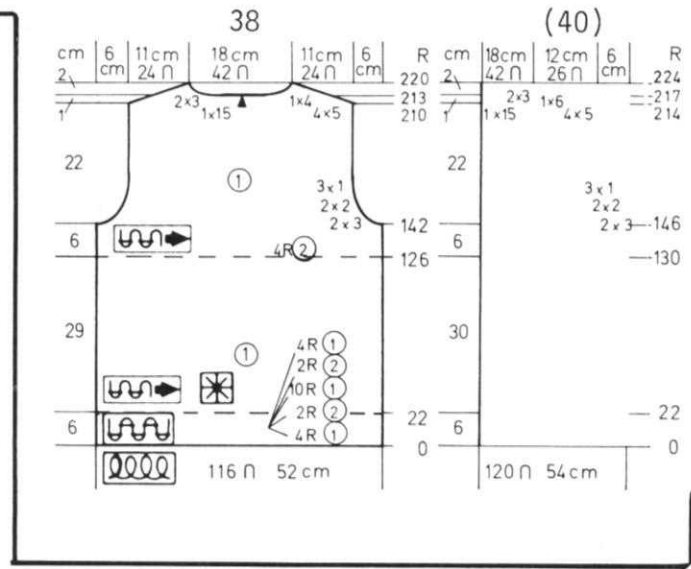

BACK: II

Cast on 136 (146) sts. and work 38 rows Ribbing. Transfer the sts. and set up as shown on the Line Drawing (see Note below Finishing). Continue in Pattern. After Row 176 (184), ON EACH SIDE bind off 10 sts. Knit to Row 260 (268).
 Put half the sts. on the left into holding position and complete the right side first.
***SHAPE SHOULDER AND NECK AT THE SAME TIME.**
FOR SHOULDER, bind off
 6 sts. 1x, 7 sts. 4x. (7 sts. 1x, 8 sts. 4x).
FOR NECK: Bind off 20 sts. then 2 sts. 2x for both sizes.
 Bring the needles on the left into working position, knit 1 row in Pattern to the left side, turn the Row Counter back to 260 (268) and complete the left half. Follow the instructions from *.

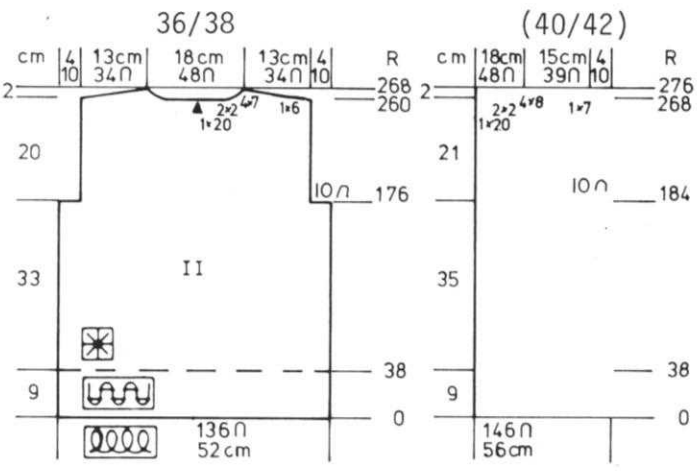

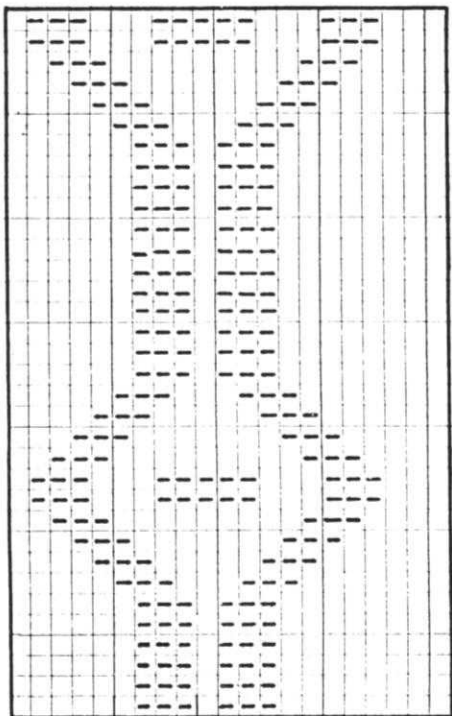

☐ = MAIN MACHINE
 ☐ = RIBBER

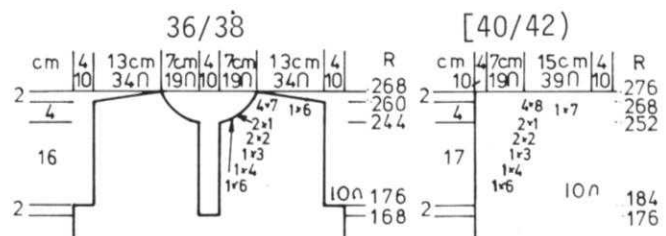

FRONT: I
 Work the front the same as the back to Row 168 (176).
 Bind off the center 10 sts., put the needles on the left into holding position and complete the right side first.
 *After Row 176 (184), bind off 10 sts. for armhole.
 Knit to Row 244 (252).
 SHAPE NECK: Bind off for both sizes,
 6 sts. 1x, 4 sts. 1x, 3 sts. 1x, 2 sts. 2x, 1 st. 2x and after Row 260 (268) SHAPE SHOULDER same as the back.
 Bring the needles on the left into working position, knit 1 row in Pattern to the left side, turn the Row Counter back to 168 (176) and complete the left half. Follow the instructions from *.

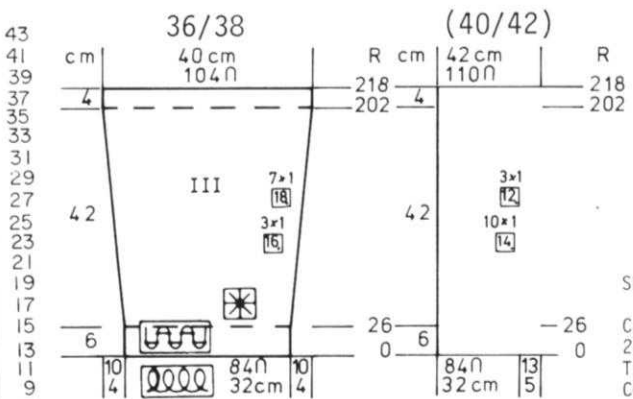

SLEEVE: III
 Cast on 84 sts. and work 26 rows Ribbing. Transfer the sts. and set into Pattern. Continue in Pattern.
 ON EACH SIDE, increase 1 st. every 16th row 3x, every 18 row 7x. (every 14th row 10x, every 12th row 3x). After Row 202, continue in Ribbing to Row 218. Bind off.

NOTE: Start Pattern in CENTER with 14 sts. on Main Machine. Transfer 3 sts. Ribber - etc. according to Line Drawing.

DK 896

WOMAN'S PULLOVER

SIZES: 8/10 (12/14) [16/18]
 YARN: Micaela
 GRAMS:
 color 1 400 450 450
 color 2 50 50 50
 color 3 50 50 50
 color 4 50 50 50
 TENSION: 8 or 9
 GAUGE: 13 sts. 17 rows = 5 cm (2")



NECKBAND: VI

Cast on 200 sts. and work in Ribbing.
 ON EACH SIDE, decrease 2 sts. 5x. After Row 10, bind off or remove onto waste yarn.

Norwegian (Fairisle) design with K1, P1 Ribbing for the Bands. Punch your own card and if you wish to use your Color Changer, remember that the card must be punched IN REVERSE.

FINISHING: See General Instructions.

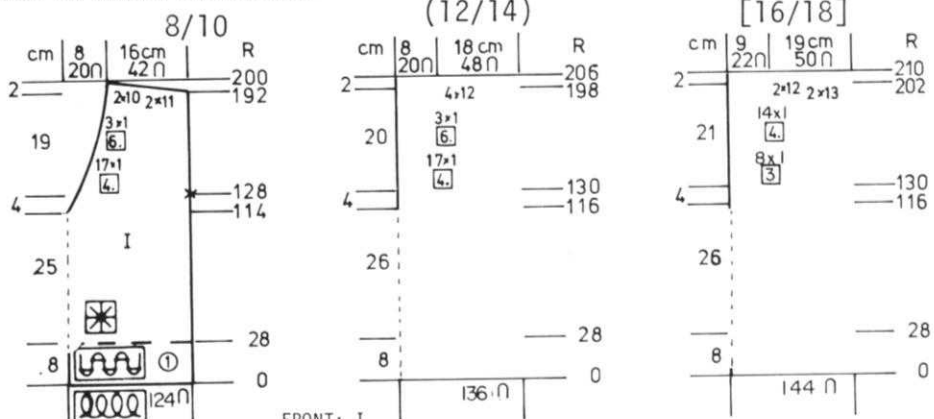

FRONT: I

Work the front the same as the back to Row 114 (116) [116].
 ON NECK SIDE, decrease 1 st. every 4th row 17x, every 6th row 3x BUT MARK SIDE EDGE AFTER ROW 128 for setting in sleeves. (Same as first size BUT MARK ROW 130 for setting in sleeves). [every 3rd row 8x, every 4th row 14x BUT MARK ROW 130 for setting in sleeves].
 After Row 192 (198) [202], SHAPE SHOULDER same as the back.

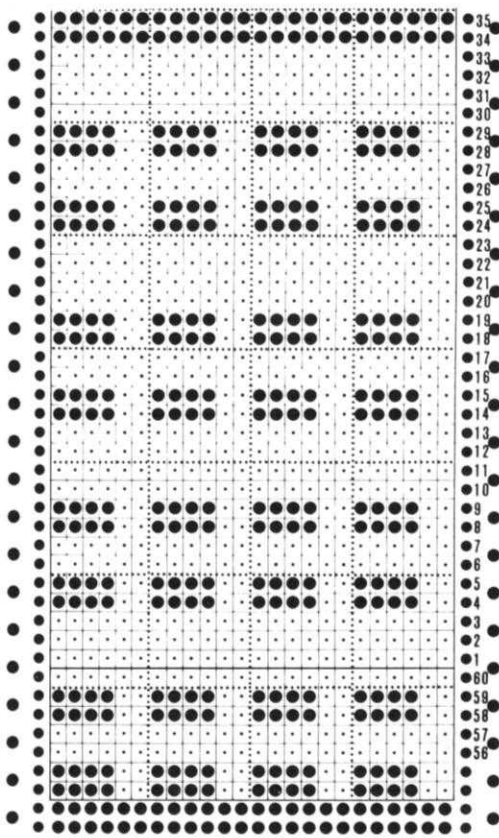

2 ROWS COLOR 1+4
 2 ROWS COLOR 1
 2 ROWS COLOR 1+4
 4 ROWS COLOR 1
 2 ROWS COLOR 1+3
 2 ROWS COLOR 1
 2 ROWS COLOR 1+3
 4 ROWS COLOR 1
 2 ROWS COLOR 1+2
 2 ROWS COLOR 1
 2 ROWS COLOR 1+2
 4 ROWS COLOR 1
 REPEAT FROM BEGINNING.

DK 896

BACK: II

Cast on 124 (136) [144] sts. with color 1 and work 28 rows Ribbing. Continue in Pattern following the color changes as shown along side of Card.

After Row 128 (130) [130], mark each side with bit of waste yarn for setting in sleeves. Knit to Row 192 (198) [202].

FOR SHOULDER (watch for Neck Shaping), bind off 11 sts. 2x, 10 sts. 2x, (12 sts. 4x), (13 sts. 2x, 12 sts. 2x), FOR NECK, after Row 196 (202) [206], put half the sts. on the left into holding position and complete the right side first.

*ON NECK SIDE, bind off 14 (14) [16] sts. 1x, 4 sts. 1x, 2 sts. 1x for all sizes.

Bring the needles on the left into working position, knit 1 row in Pattern to the left side, turn the Row Counter back to 196 (202) [206] and complete the left half. Follow the instructions from *.

SLEEVES: III

Cast on 68 (68) [72] sts. with color 1 and work 14 rows in Ribbing. Continue in Pattern with color changes as given.

ON EACH SIDE, increase 1 st. every 10th row 11x, every 5th row 5x. (every 10th row 3x, every 8th row 15x). [Same as 2nd size]. After Row 164, bind off.

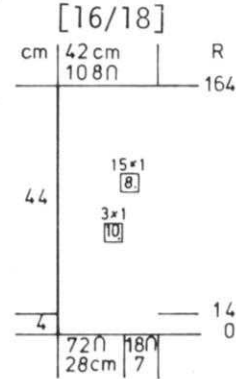
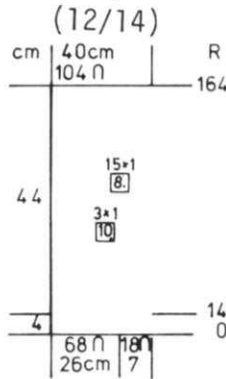
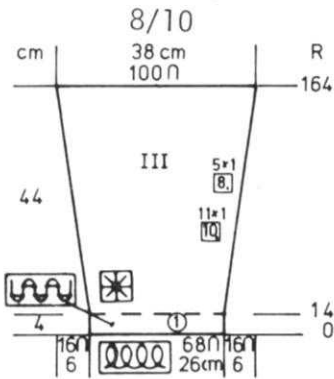
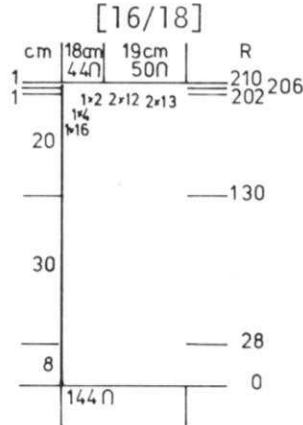
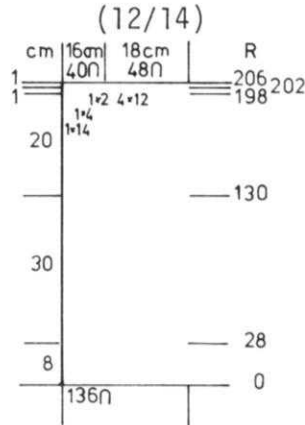
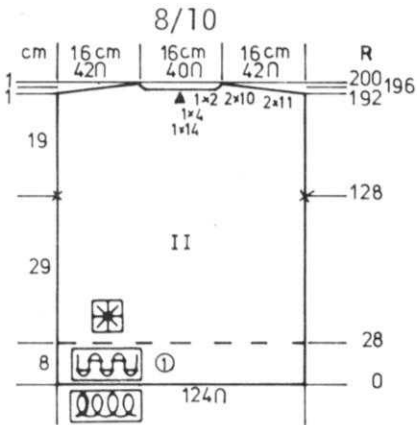

DK 897

WOMAN'S VEST

SIZES: 10/12 (14/16) [18/20]
 YARN: Amore
 GRAMS: 350 350 400
 TENSION: 8 to 10
 GAUGE: 10 sts. 25 rows = 5 cm (2")

A Tuck Stitch Pattern worn on the Pur1 side. Punch your own Card and push in BOTH TUCK buttons. 840 machine owners can use Card No. 26 of your original set of punch cards. Sleeve bands and slits are K1, P1 Ribbing. Crochet is used for fronts and neck trim.

FINISHING: See General Instructions. Sew Ribbing in place on slits. Mark left front for placement of buttons and work Buttonholes on right front. Work 2 rows double crochet around neck and down fronts then 1 row reverse single crochet (be sure to leave openings for buttonholes on right front).

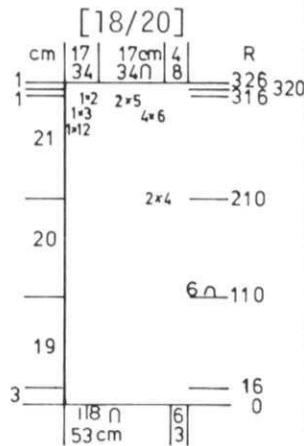
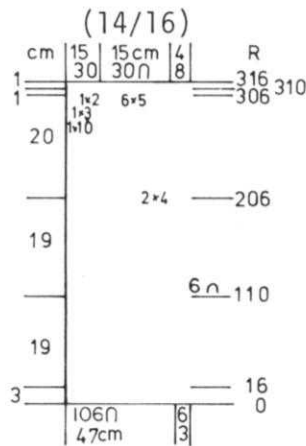
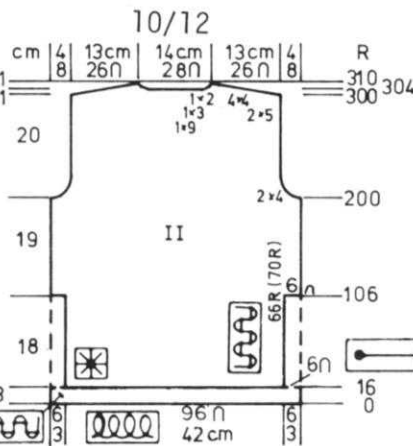

BACK: II

Cast on 96 (106) [118] sts. and work 16 rows Ribbing. Transfer the ribber sts. then put 6 sts. ON EACH SIDE onto a stitch holder. Continue in Pattern. Knit to Row 106 (110) [110]. ON EACH SIDE, cast on 6 sts. Knit to Row 200 (206) [210]. SHAPE ARMHOLE: ON EACH SIDE, bind off 4 sts. 2x for all sizes. Knit to Row 300 (306) [316]. SHAPE SHOULDER and WATCH FOR NECK SHAPING. FOR SHOULDER, ON EACH SIDE, bind off 5 sts. 2x, 4 sts. 4x (5 sts. 6x) [6 sts. 4x, 5 sts. 2x]

AT THE SAME TIME, after Row 304 (310) [320], SHAPE NECK: Put half the sts. on the left into holding position and complete the right side first. *ON NECK SIDE, bind off 9 (10) [12] sts. 1x, then 3 sts. 1x, 2 sts. 1x for all sizes. Bring the needles on the left into working position, knit 1 row in Pattern to the left side, turn the Row Counter back to 304 (310) [320] and complete the left side. Follow the instructions from * but don't forget to complete the shoulder shaping.

10/12

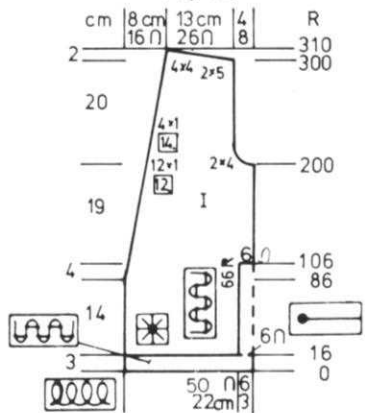

(14/16)

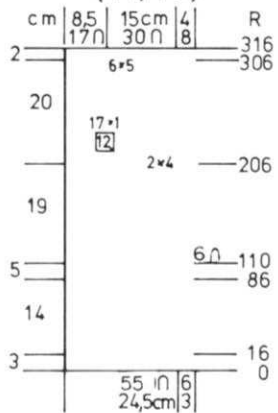

[18/20]

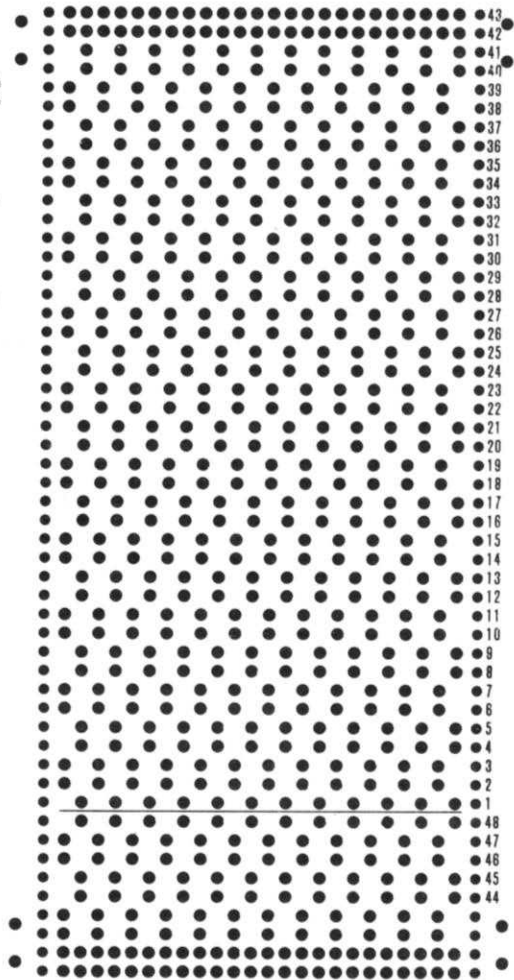
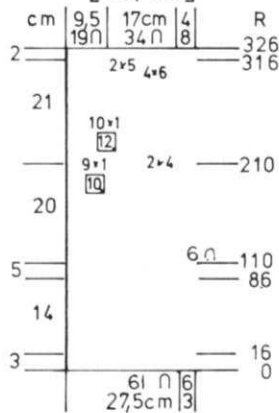

FRONT: I Make 1, reverse 1.

Cast on 50 (55) [61] sts. and work 16 rows Ribbing. Transfer the Ribber sts. then remove 6 sts. on the RIGHT (left for 2nd section) onto a stitch holder.

After Row 86, ON FRONT EDGE, decrease 1 st.

every 12th row 12x, every 14th row 4x, (every 12th row 17x), [every 10th row 9x, every 12th row 10x], BUT AT THE SAME TIME after Row 106 (110) [110], on the RIGHT (left), cast on 6 sts.

After Row 200 (206) [210], SHAPE ARMHOLE same as the back.

After Row 300 (306) [316], SHAPE SHOULDER same as the back.

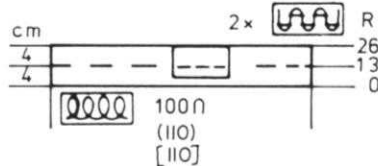

ARMBANDS: Make 2.

Sew shoulders first, then pick up 100 (110) [110] sts. around armhole and work 26 rows Ribbing. Hang the hem and bind off or you can remove the sts. onto waste yarn and turn the ribbing to the inside and hem.

SLIT BANDS:

Pick up the 6 sts. held on waste yarn for the slit. Work 66 (70) [70] rows of Ribbing. Remove onto waste yarn. Sew bands in place on the slits.

KK 898

BABY'S SUIT

SIZES:	3 Mo.	(6 Mo.)	[9 Mo.]
YARN:	Mohair		
GRAMS:			
color 1	50	50	50
color 2	100	150	150
color 3	50	50	50
TENSION:	6 or 7		
GAUGE:	13 1/2 sts. 18 rows = 5 cm (2")		

Stockinette stitch with changes in color as shown on the Chart. Bands are K1, P1 Ribbing. Embroider flowers on front of Jacket and on Cap.

FINISHING: Jacket: Sew shoulder seams, sides and underarms. With color 3, work 1 row single crochet down fronts and around neckline. Mark for buttons and buttonholes then work 1 row picot, leaving openings for buttonholes on right front. Sew on buttons and embroider flowers as shown on picture.

Pants: Sew leg seams from the bottom up to 22 (24) [25] cm, then sew front and back seams. Turn under waistband and sew to the inside. Make cord and pull through casing. Make cord for legs and pull through above ribbing at ankles (see picture).

CAP: Sew back seam then turn lower edge in half and sew down to the inside. Put some cotton in the hem so it is round. Embroider flowers same as on the Jacket.

3 Months

(6 Months) [9 Months]

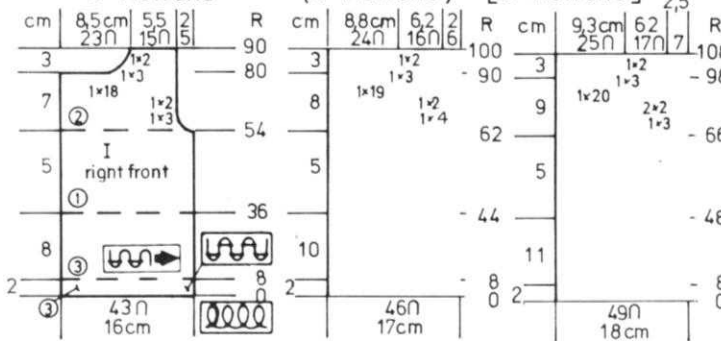

RIGHT FRONT: I

Cast on 43 (46) [49] sts. with color 3 and work 8 rows Ribbing. Continue in Stockinette stitch with color changes as shown on the Chart. After Row 54 (62) [66], SHAPE ARMHOLE same as the back. After Row 79 (89) [97], SHAPE NECK: Bind off 18 (19) [20] sts. 1x, then for all sizes, 3 sts. 1x, 2 sts. 1x. After Row 90 (100) [108], bind off the remaining sts.



KK 898

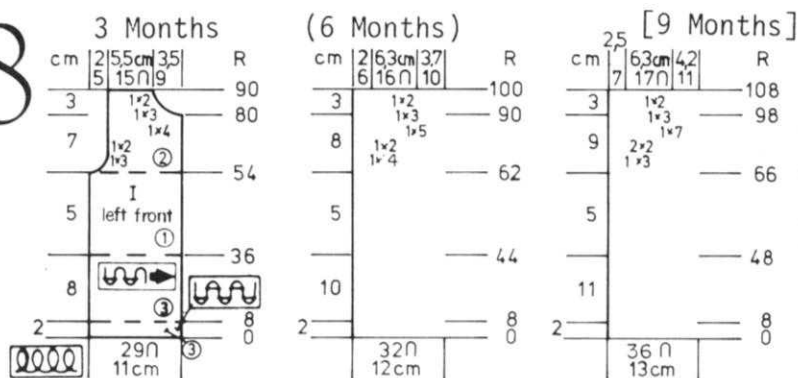

LEFT FRONT: I

Cast on 29 (32) [36] sts. with color 3 and work 8 rows Ribbing. Continue in Stockinette stitch with color changes same as right front.
 After Row 53 (61) [65], SHAPE ARMHOLE same as the back then knit to Row 80 (90) [98].
 SHAPE NECK: Bind off 4 (5) [7] sts. 1x, then 3 sts. 1x, 2 sts. 1x, for all sizes. After Row 90 (100) [108], bind off the remaining sts.

3 Months

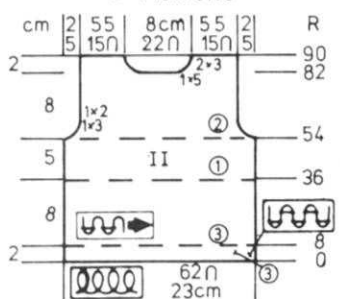

6 Months

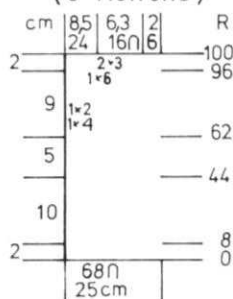

9 Months

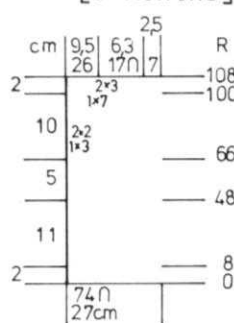

JACKET BACK: II

Cast on 62 (68) [74] sts. with color 3 and work 8 rows Ribbing. Continue in Stockinette stitch with color 3 to row 36 (44) [48] then change to color 1.
 After Row 54 (62) [66], change to color 2 and SHAPE ARMHOLE: ON EACH SIDE, bind off 3 sts. 1x, 2 sts. 1x. (4 sts. 1x, 2 sts. 1x). [3 sts. 1x, 2 sts. 2x].
 After Row 82 (96) [100], put half the sts. on the left into holding position and complete the right side first.
 *ON NECK SIDE, bind off 5(6) [7] sts. 1x, then 3 sts. 2x for all sizes. After Row 90 (100) [108], bind off the remaining sts. Bring the needles on the left into working position, knit 1 row to the left side, turn the Row Counter back to 82 (96) [100] and complete the left half. Follow the instructions from *.

SLEEVES: IV

Cast on 39 (42) [45] sts. with color 3 and work 10 rows Ribbing. Continue in Stockinette stitch with color 1, and ON EACH SIDE, increase 1 st. every 30th row 2x. After Row 36, continue with color 2.
 After Row 62 (68) [76], SHAPE CAP: ON EACH SIDE, bind off 3 sts. 1x, 2 sts. 1x, 1 st. 5x, 2 sts. 1x, 3 sts. 1x. (3 sts. 1x, 2 sts. 1x, 1 st. 6x, 2 sts. 1x, 3 sts. 1x). [3 sts. 1x, 2 sts. 1x, 1 st. 7x, 2 sts. 1x, 3 sts. 1x].
 After Row 80 (88) [98], bind off the remaining sts.

3 Months

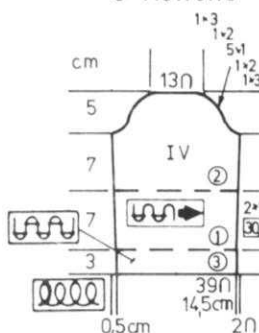

6 Months



9 Months

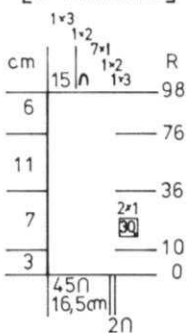

3 Months

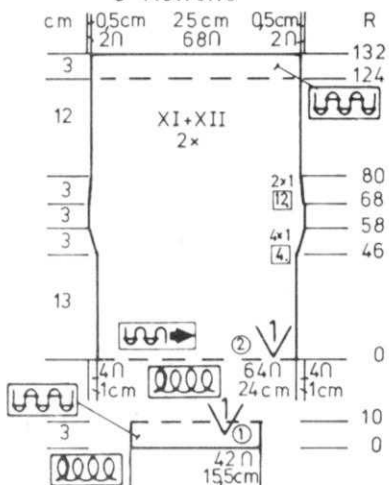

6 Months

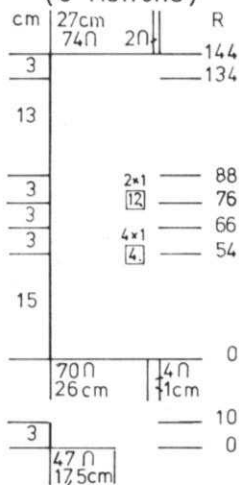

9 Months

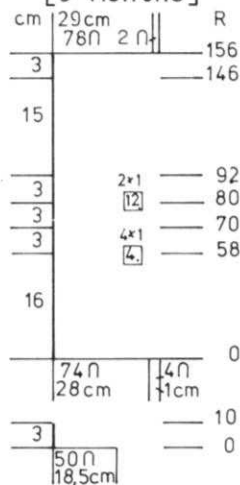

PANTS: Make 1, reverse 1.

With contrast waste yarn, cast on 64 (70) [74] sts. work Stockinette stitch. Knit 8 to 10 rows then change to garment yarn, color 2 and continue in Stockinette stitch.
 After Row 46 (54) [54], ON EACH SIDE, increase 1 st. every 4th row 4x for all sizes.
 After Row 68 (76) [80], ON EACH SIDE decrease 1 st. every 12th row 2x for all sizes.
 After Row 124 (134) [146] continue with K1, P1 Ribbing to Row 132 (144) [156]. Bind off.
 Hang the open sts. held on waste yarn back onto the machine, decreasing to 42 (47) [50] sts. Transfer every other stitch to the Ribber and work 10 Pws K1, P1 Ribbing. Bind off.

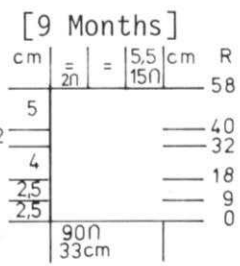
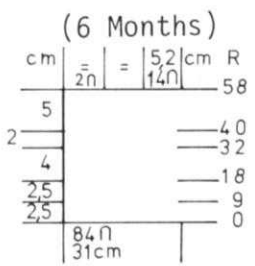
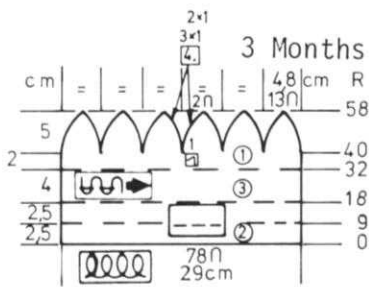

CAP:
 Cast on 78 (84) [90] sts. with color 2 and work Stockinette stitch. After Rows 8 and 17, knit the next row with Tension 10 (markings for hem). Be sure to turn tension back. Change colors as shown on the Chart.
 After Row 40, divide into 6 sections and hang one stitch onto next stitch. Work 1 section at a time. Put the remaining sections into holding position. ON EACH SIDE, decrease 1 st. every 4th row 3x, then every 2nd row 2x. After Row 58, put the remaining 2 sts. on a safety pin. HINT: - Hang the stitch from the completed section onto machine as you knit another section on every 2nd row then you will not have to sew up the points. When completed, pull yarn through the sts. held on pin and tie securely. Sew back seam.

KK 899

CHILD'S DRESS WITH VEST

SIZES: 12 Mo. (18 Mo.)
 YARN: Fortissima
 GRAMS: color 1 150 150
 color 2 50 50
 TENSION: 5 to 7
 GAUGE: Stock. 14 sts. 21 1/2 rows = 5 cm
 Pat. 12 sts. 36 rows = 5 cm (2")



SLEEVES: III
 Cast on 54 (58) sts. with color 2 and work 18 rows Ribbing. Continue in Stockinette stitch with color 1.
 ON EACH SIDE, increase 1 st. every 20 rows 3x for both sizes.
 After Row 78 (82) SHAPE CAP:
 ON EACH SIDE, bind off 3 sts. 1x, 2 sts. 2x, 1 st. 12x, 2 sts. 2x for both sizes.
 After Row 112 (116), bind off the remaining sts.

The dress is Stockinette stitch with Ribbed Bodice. The Vest is a Tuck Pattern using two colors. Punch your own Card and if you own a Color Changer you can use it. Push in both Tuck Buttons.

FINISHING: Dress. See General Instructions. Single crochet around slit opening, making chains for buttonholes. Sew on buttons. Single crochet around Collar. Vest: See General Instructions. Sew on side bands.

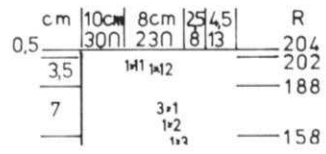
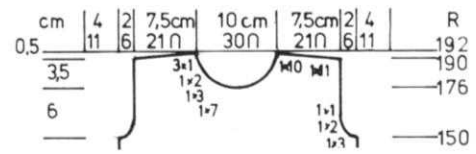
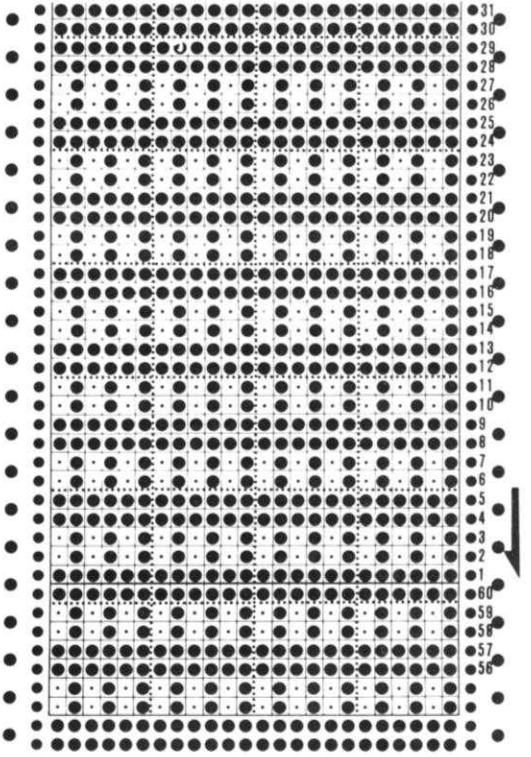
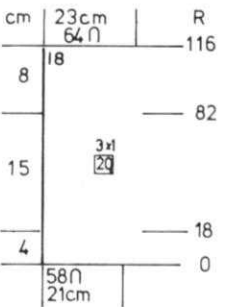
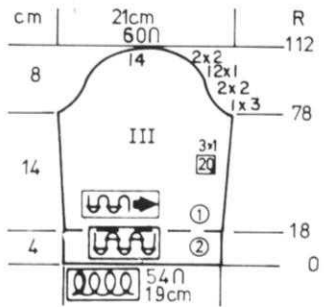

FRONT: I
 Work the front the same as the back to Row 176 (188). Put half the sts. on the left into holding position and complete the right side first.

DRESS BACK: II
 Cast on 104 (112) sts. with color 1 and work Stockinette stitch. After Row 16, hang the hem. Knit to Row 50 (58).
 ON EACH SIDE, decrease 1 st. every 8th row 10x for both sizes.
 After Row 128 (136) transfer every other stitch to the Ribber and continue in K1, P1 Ribbing.
 After Row 150 (158) SHAPE ARMHOLE: ON EACH SIDE, bind off 3 sts. 1x, 2 sts. 1x, 1 st. 1x. (3 sts. 1x, 2 sts. 1x, 1 st. 3x).
 After Row 176 (188) divide in the center for slit. Put the needles on the left into holding position and complete the right side first.
 *Knit to Row 190 (202).
 SHAPE SHOULDER: Bind off 11 sts. 1x, 10 sts. 1x. (12 sts. 1x, 11 sts. 1x).
 After Row 192 (204), bind off the remaining sts.
 Bring the needles on the left into working position, knit 1 row to the left side, turn the Row Counter back to 176 (188) and complete the left half. Follow the instructions from *.

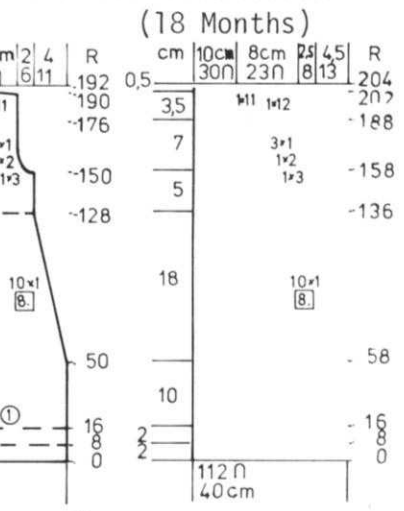
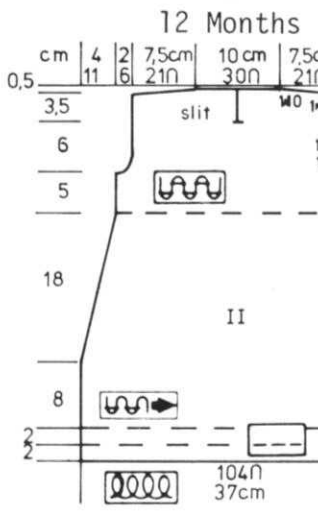

KK 899

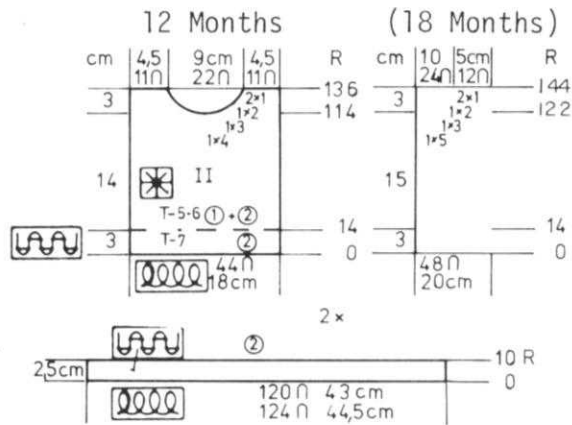

VEST ARMBANDS: Make 2.

Cast on 120 (124) sts. with color 2 and work 10 rows Ribbing. Bind off or remove onto waste yarn.

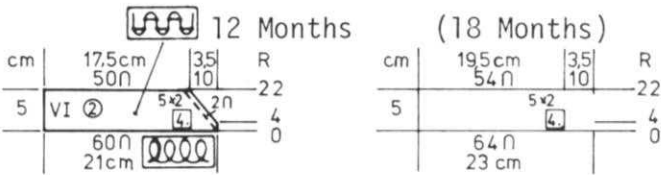

VEST BACK: Worn on Pur1 side.

Cast on 44 (48) sts. with color 2 and work 14 rows Ribbing with Tension 7.

Continue in Pattern with Tension 5 or 6.

Knit to Row 114 (122).

SHAPE NECK: Put half the sts. on the left into holding position and complete the right side first.

*ON NECK SIDE, bind off

4 (5) sts. 1x, 3 sts. 1x, 2 sts. 1x, 1 st. 2x.

After Row 136 (144), bind off the remaining sts.

Bring the needles on the left into working position, knit 1 row in Pattern to the left side, turn the row counter back to 114 (122) and complete the left half. Follow the instructions from *.

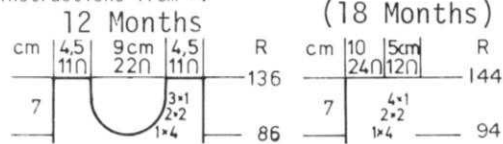

COLLAR: Make 1, reverse 1.

Cast on 60 (64) sts. with color 2 and work in Ribbing.

Work all decreases with the full fashion method.

ON THE RIGHT (left for 2nd section), decrease 2 sts. every 4th row 5x.

After Row 22, bind off.

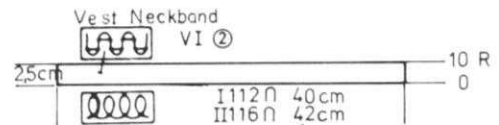

VEST NECKBAND:

Cast on 112 (116) sts. with color 2 and work 10 rows Ribbing. Bind off or remove onto waste yarn.

VEST FRONT: I

Work the front the same as the back to Row 86 (94).

Put half the sts. on the left into holding position and complete the right side first.

*SHAPE NECK: ON NECK SIDE, bind off 4 sts. 1x, 2 sts. 2x, 1 st. 3x (4x). After Row 136 (144), bind off the remaining sts.

Bring the needles on the left into working position, knit 1 row in Pattern to the left side, turn the Row Counter back to 86 (94) and complete the left half. Follow the instructions from *.

KK 900

CHILD'S SUIT

SIZES: 12 Mo. 18 Mo.

YARN: See Kits listing.

color 1 & 2 =
color 3 =
color 4 =

GRAMS:
color 1 300 300
color 2 100 100
color 3 200 200
color 4 100 100

TENSION: 10

GAUGE: 12 sts. 16 rows = 5 cm (2")

A Weaving Pattern with color changes as shown on the Charts. Punch Card. Bands are K1, P1 Ribbing using hand knitting needles.

FINISHING: See General Instructions for Pullover. Pants: Sew seams.

Single crochet waistband as follows.

Row 1. Work single crochet

Row 2. Single crochet in first stitch,

*chain 2, single crochet in 3rd st.

REPEAT from *.

Row 3. Single crochet.

Pull elastic through beading made for band.

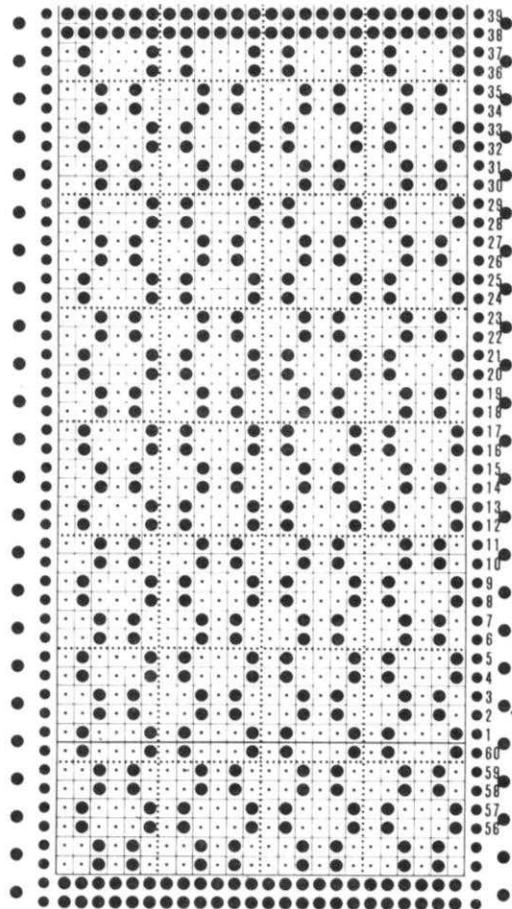

NOTE: WEAVING Pattern - Cast on with color 3 and always work 2 rows color 1 then 2 rows color 2 for the weaving.

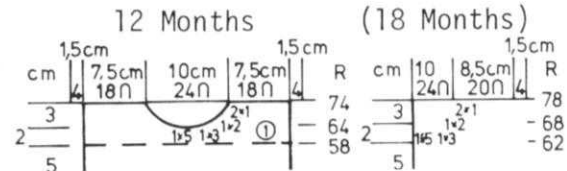

PULLOVER FRONT: I

Work the front the same as the back to Row 58 (62).

Continue weaving with color 1 only and after Row 64 (68), SHAPE NECK: Put half the sts. on the left into holding position and complete the right side first.

*ON NECK SIDE, bind off

5 sts. 1x, 3 sts. 1x, 2 sts. 1x, 1 st. 2x for both sizes.

After Row 74 (78), bind off the remaining sts.

Bring the needles on the left into working position, knit 1 row in Pattern to the left side, turn the Row Counter back to 64 (68) and complete the left half. Follow the instructions from *.

WAISTBAND FOR PULLOVER

Pick up the sts. held on waste yarn, decreasing to 54 (56) sts. Work K1, P1 Ribbing for 2" with color 4.

NECKBAND:

Pick up 78 (84) sts. around neckline and with hand knitting needles work K1, P1 Ribbing for 2" with color 4.

12 Months

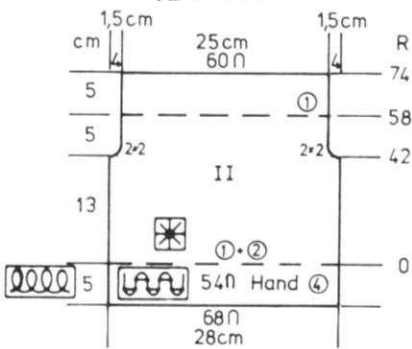

(18 Months)

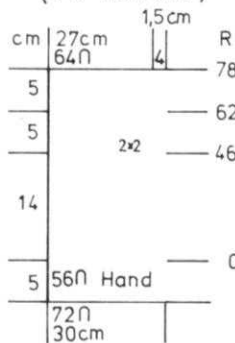

PULLOVER BACK: II

OPEN CAST ON: Cast on 68 (72) sts. with waste yarn. After knitting 8 to 10 rows, change to color 3 and continue in Weaving Pattern. Counter 0. Knit to Row 42 (46).
SHAPE ARMHOLE: ON EACH SIDE, bind off 2 sts. 2x for both sizes.
After Row 58 (62) continue the weaving with color 1 only.
After Row 74 (78) bind off.

SLEEVES:

Cast on with waste yarn same as front and back. Cast on 50 (55) sts. Use color 3 with color changes same as back & front. Work in Pattern and ON EACH SIDE, increase 1 st. every 20th Row 2x for both sizes.
After Row 54 (58) SHAPE CAP: ON EACH SIDE, bind off 2 sts. 1x, 1 st. 7x for both sizes.
After Row 70 (74), bind off remaining sts.

Pick up the sts. held on waste yarn same as you did for front and back, decreasing to 32 (34) sts. Work 2 inches K1, P1 Ribbing with color 4.

DK 902



WOMAN'S PULLOVER

SIZES: 8/10 (12)
YARN: Pingouin Oued
GRAMS:
color 1 200 250
color 2 100 150
color 3 100 150
color 4 100 150
TENSION: 7 to 9
GAUGE: 11 sts. 15 rows = 5 cm (2")

Knitted over EVERY OTHER NEEDLE in a SLIP STITCH Pattern. Punch your own Card and push in BOTH PART BUTTONS. The bands are K1, P1 Ribbing.

FINISHING: See General Instructions.

12 Months

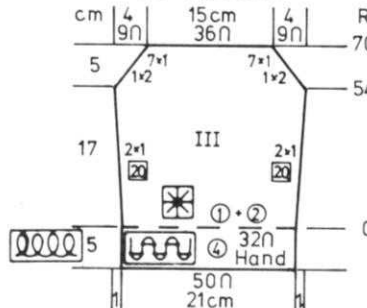

(18 Months)

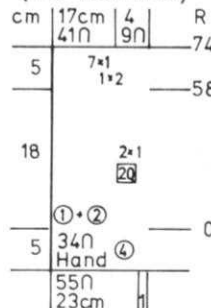

12 Months

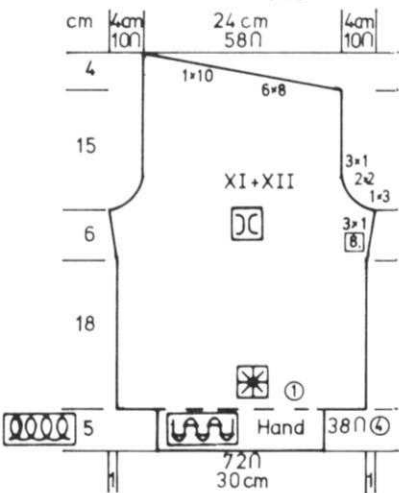

(18 Months)

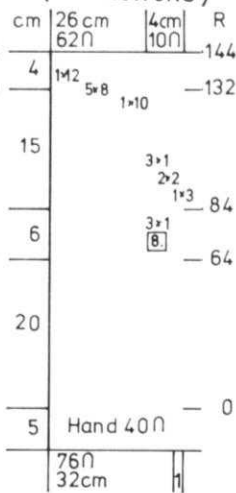

PANTS: Make 1, reverse 1.

Use OPEN CAST ON same as back and front.
Cast on 72 (76) sts. work with color 3 for the knitting and color 1 only for the weaving.
After Row 58 (64), ON EACH SIDE, increase 1 st. every 8th row 3x for both sizes.
After Row 78 (84), ON EACH SIDE, bind off for both sizes, 3 sts. 1x, 2 sts. 2x, 1 st. 3x. Knit to Row 126 (132), bind off 8 sts. 6x, 10 sts. 1x. (10 sts. 1x, 8 sts. 5x, 12 sts. 1x).

Pick up the sts. held on waste yarn onto hand knitting needles and decrease to 38 (40) sts. Work K1, P1 Ribbing for 2" with color 4.

2x VI

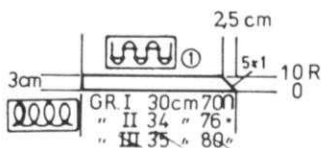

NECKBAND: Make 2.

Cast on 70 (76) stitches with color 1 and work 10 rows Ribbing. Bind off or remove onto contrast waste yarn.



8/10

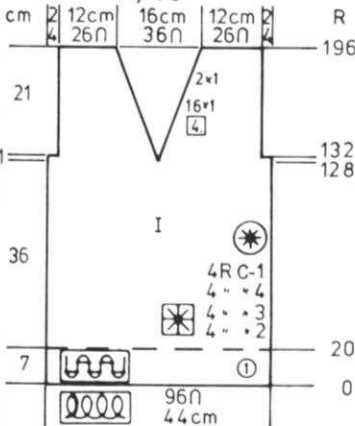

(12)

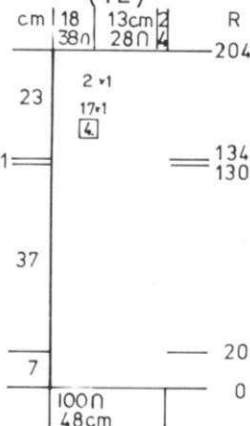

FRONT: I

Work the front the same as the back to Row 128 (130). Divide in the center. Put the needles on the left into holding position and complete the right side first.
*ON NECK SIDE, decrease 1 st. every 4th row 16x, (17x) then decrease 1 st. every 2nd row 2x, BUT AT THE SAME TIME, after Row 132 (134) bind off 4 sts. for armhole.
After Row 196 (204), bind off the remaining sts.
Bring the needles on the left into working position, knit 1 row in Pattern to the left side, turn the Row Counter back to 128 and complete the left half. Follow the instructions from *.



DK 902

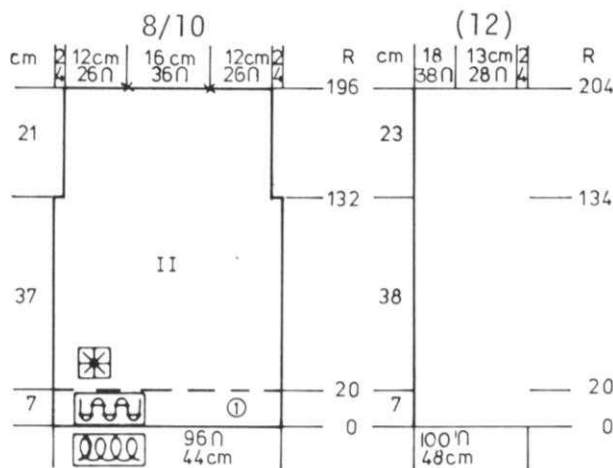
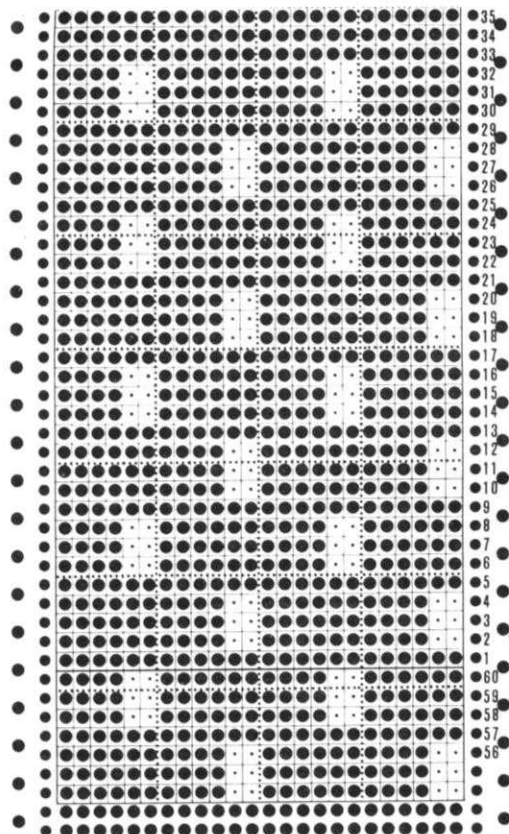

BACK: II

Cast on 96 (100) sts. with color 1 and work 20 rows Ribbing. Transfer the ribber sts. and work over EVERY OTHER NEEDLE. Continue in Pattern with changes in color as shown on the FRONT. Knit to Row 132 (134). ON EACH SIDE, bind off 4 sts. then knit to Row 196 (204). Bind off the center 36 sts. for neck then bind off each shoulder separately.

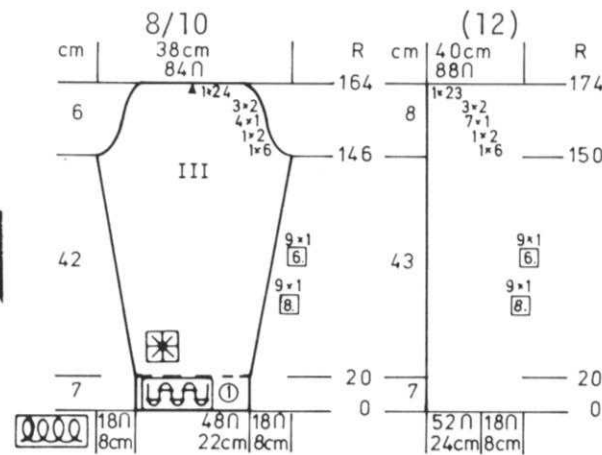

SLEEVES: III

Cast on 48 (52) sts. with color 1 and work 20 rows Ribbing. Continue in Pattern same as front and back. ON EACH SIDE, increase 1 st. every 8th row 9x, every 6th row 9x. After Row 146 (150), SHAPE CAP: ON EACH SIDE, bind off 6 sts. 1x, 2 sts. 1x, 1 st. 4x, 2 sts. 3x. (6 sts. 1x, 2 sts. 1x, 1 st. 7x, 2 sts. 3x). After Row 164 (174), bind off the remaining sts.

DK 901

WOMAN'S JACKET

SIZES: Fits sizes 10 to 16

YARN: Amore

GRAMS:

color 1 100
color 2 100
color 3 100
color 4 50
color 5 50

TENSION: 7 to 9

GAUGE: 10 sts. 12 rows = 5 cm (2")

The Jacket is knitted sideways on the machine in stripes and a Norwegian Design. Punch your own Card. All bands are K1, P1 Ribbing.

FINISHING: See General Instructions.

NOTE: When working the Punch Card, you must remove the 2nd color from the Feeder when knitting plain rows

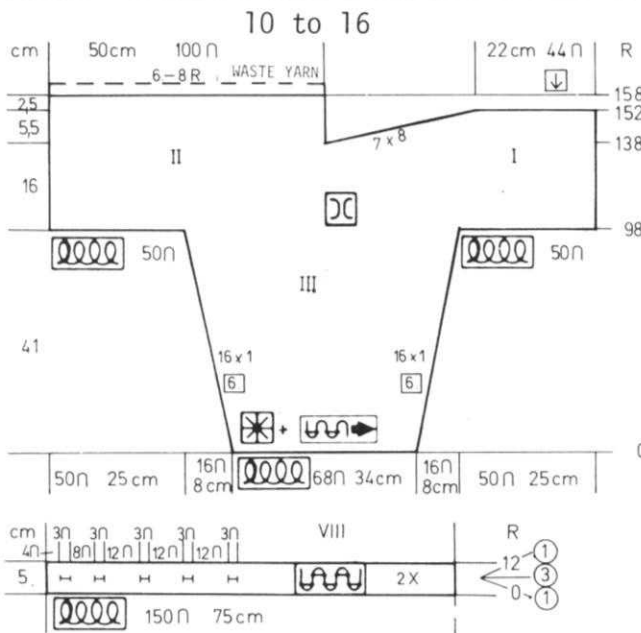

BEGIN AT SLEEVE EDGE.

Cast on 68 sts. with color 1 and work 4 rows Stockinette stitch then CONTINUE IN PATTERN. ON EACH SIDE, increase 1 st. every 6th row 16x. After Row 98, ON EACH SIDE, cast on 50 sts. (200 sts.) After Row 138, put half the sts. on the left into holding position and complete the right side first. ON NECK SIDE, bind off 8 sts. 7x. After Row 152, bind off the remaining sts. Bring the needles on the left into working position, knit 1 row to the left side, turn the Row Counter back to 138 and complete the left side. Knit in Pattern to Row 158, then remove the sts. onto contrast waste yarn. WORK THE 2nd HALF with REVERSE shaping. Remove the sts. onto waste yarn (or you can use your reversing bar) then hang them back onto the machine with knit side facing you then hang the first section onto these same needles with pur1 side facing you. Bind off the sts. together for center back seam.

FRONT & NECKBANDS: Make 2, 1 without Buttonholes.

Cast on 150 sts. with color 1 and work in Ribbing, 5 rows color 1, 2 rows color 2, 5 rows color 1 AND AT THE SAME TIME, after Row 6, make buttonholes counting from the left edge over needles 5 to 7, leave 8, buttonhole over the next 3 *leave 12, buttonhole over the next 3 and REPEAT FROM * until there are 5 buttonholes in all. After Row 12, bind off or remove onto waste yarn.

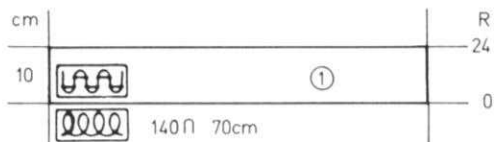

WAISTBAND:

Cast on 140 sts. with color 1 and work 24 rows Ribbing. Bind off or remove onto contrast waste yarn.

HP 903

MAN'S PULLOVER

SIZES: 38 (40)
YARN: Fortissima

GRAMS:
color 1 300 350
color 2 150 150
color 3 50 50

TENSION:
Stock: 6 to 8
Pat. 7 to 9

GAUGE:
Stock: 13 sts. 20 rows = 5 cm (2")
Pat: 14 sts. 25 rows = 5 cm (2")

A simulated Seed Stitch with color stripes as shown on the Chart. Bands are K2, P2 Ribbing as is the Collar. Punch your own Card and push in ONLY ONE TUCK BUTTON for Pattern.

FINISHING: See General Instructions.

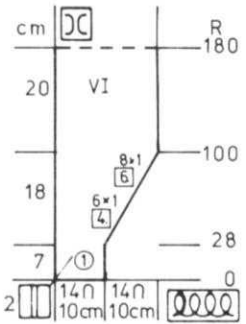
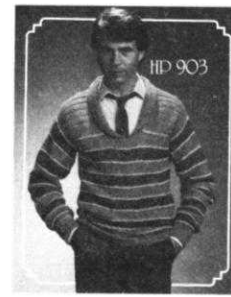
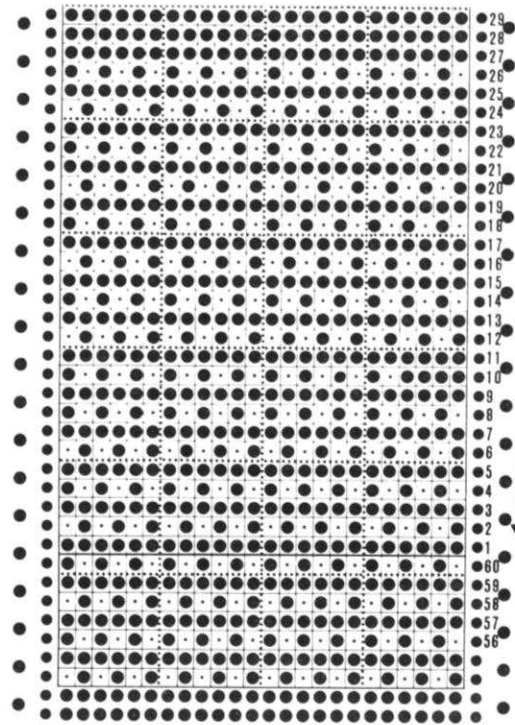

COLLAR: 2 [K2, P2] 14n 14n 0

Cast on 14 sts. and work K2, P2 Ribbing.
After Row 28, ON THE RIGHT, increase 1 st. every 4th row 6x, every 6th row 8x.
Knit to Row 180 and mark for center collar.
Now work backwards to complete the 2nd half. Bind off the remaining 14 sts.

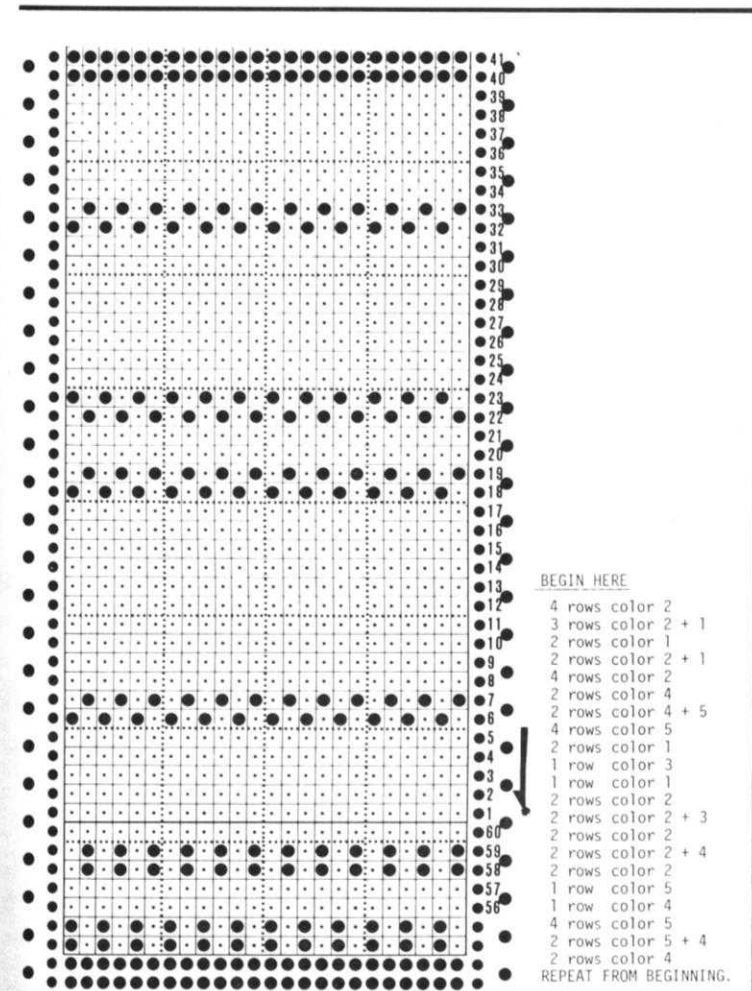

BEGIN HERE

4 rows color 2
3 rows color 2 + 1
2 rows color 1
2 rows color 2 + 1
4 rows color 2
2 rows color 4
2 rows color 4 + 5
4 rows color 5
2 rows color 1
1 row color 3
1 row color 1
2 rows color 2
2 rows color 2 + 3
2 rows color 2 + 4
2 rows color 2
1 row color 5
1 row color 4
4 rows color 5
2 rows color 5 + 4
2 rows color 4

REPEAT FROM BEGINNING.

CUFF BANDS: Make 2

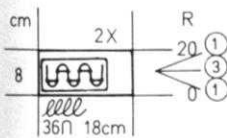

Cast on 36 sts. with color 1 and work in Ribbing.
Knit 14 rows color 1, 2 rows color 3, 4 rows color 1.
Bind off or remove onto contrast waste yarn.

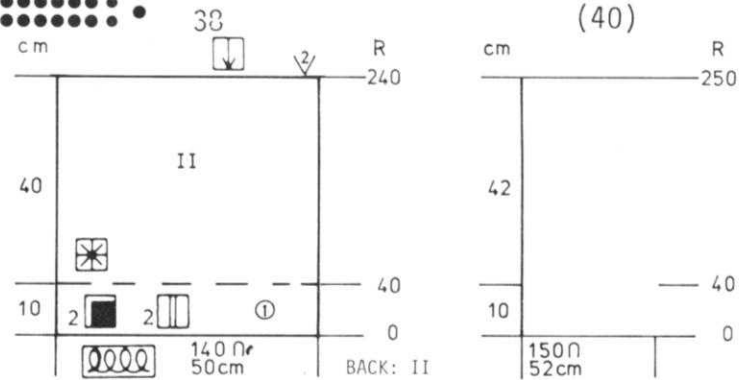

Work the back the same as the front but omit the neck opening.
After Row 240 (250), bind off all sts.

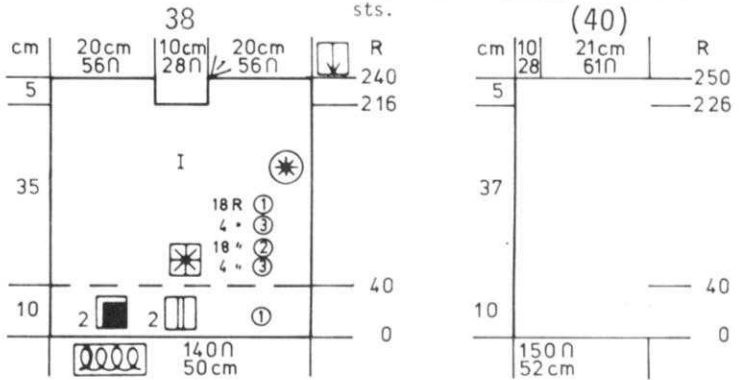

FRONT: I

Cast on 140 (150) sts. with color 1 and work 40 rows Ribbing.
Continue in Pattern with color stripes as shown on the Chart.
After Row 216 (226), bind off the center 28 sts., put the needles on the left into holding position and complete the right side first.
*After Row 240 (250), bind off the remaining sts.
Bring the needles on the left into working position, knit 1 row in Pattern to the left side, turn the Row Counter back to 216 (226) and complete the left half. Follow the instructions from *.



HP 903

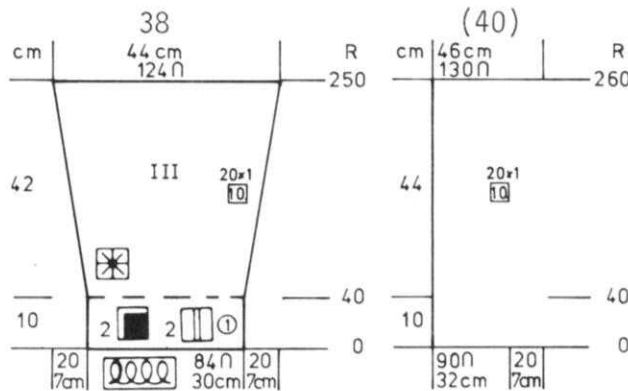

SLEEVES: III

Cast on 84 (90) sts. with color 1 and work 40 rows K2, P2 Ribbing. Continue in Pattern same as front and back.
ON EACH SIDE, increase 1 st. every 10th row 20x for both sizes.
After Row 250 (260), bind off.

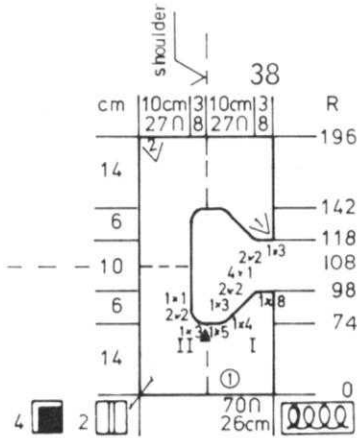

YOKE:

Cast on 70 sts. with color 1 and work in K4, P2 Ribbing. After Row 74 (84) counting from the center, bind off 3 sts. on the left and 5 sts. on the right. Put all the remaining sts. on the right into holding position and the left side first.
ON NECK SIDE, bind off 2 sts. 2x, then 1 st. 1x.
Knit to Row 108 (114) and mark the left side for center, then knit to Row 136 (142).

ON NECK SIDE, cast on 1 st. 1x, then 2 sts. 2x.
After Row 142 (148), put these sts. into holding position.
Bring the needles on the right into working position, turn the Row Counter back to 74 (84) and ON NECK SIDE, on every every 2nd row, bind off 4 sts. 1x, 3 sts. 1x, 2 sts. 2x, 1 st. 4x, 2 sts. 2x, 3 sts. 1x, then 8 sts. 1x.
Over the same needles where you bound off the last 8 sts. immediately cast on 8 sts. Put Row Counter at 118 (124) and work backwards, casting on the sts. instead of binding off.
After Row 142 (148), cast on 8 sts. in the center and bring all needles into working position.
Knit to Row 196 (208) then bind off.

DK 904

WOMAN'S SHAWL

SIZES: to fit all.
YARN: Vienna
GRAMS: 100 grams for each of 6 colors.
TENSION: 8 to 9
GAUGE: 23 sts. 30 rows = 5 cm (2")

The Shawl is knitted in Stockinette stitch in 2 sections. Use BOTH needlebeds so that you will have 400 sts.

FINISHING: Sew the two sections together. Single crochet around then make fringe. See Picture.

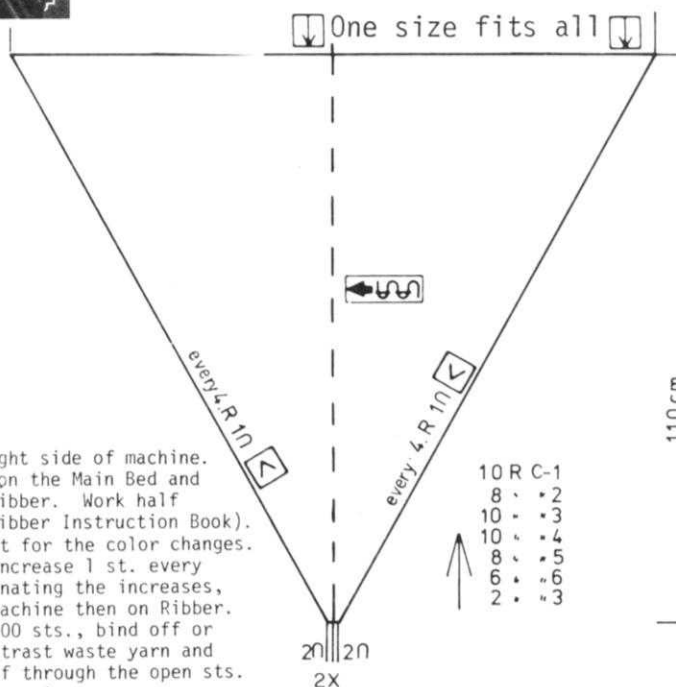

Begin at the right side of machine. Cast on 2 sts. on the Main Bed and 2 sts. on the Ribber. Work half circular. (See Ribber Instruction Book). Follow the Chart for the color changes. ON EACH SIDE, increase 1 st. every 2nd row - alternating the increases, first on main machine then on Ribber. When you have 400 sts., bind off or remove onto contrast waste yarn and crochet bind off through the open sts. then remove the waste yarn. Make another section the same way.

10 R C-1
8 . *2
10 . *3
10 . *4
8 . *5
6 . *6
2 . *3

DK 906

WOMAN'S PULLOVER

SIZES: 12 (14)
YARN: Vienna
GRAMS: color 1 400 450
Few yards of 5 other colors for Motif.
TENSION: 5 to 7
GAUGE: 12 sts. 15 rows = 5 cm (2")

Stockinette stitch with a Motif on the front section. Bands are K2, P2 (or K1, P1) Ribbing.

FINISHING: See General Instructions. Sew Motif in place.

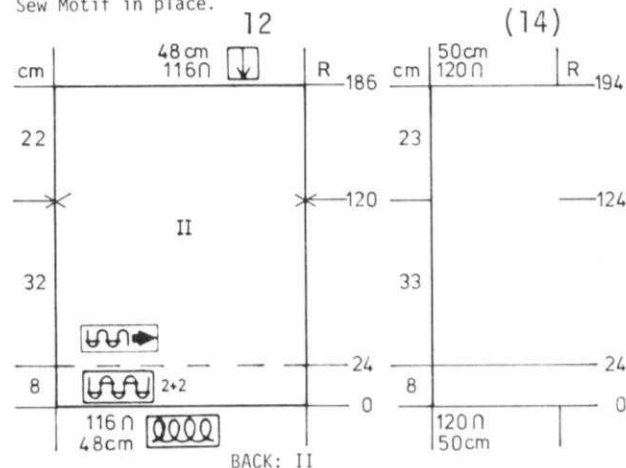

BACK: II

Cast on 116 (120) sts. and work 24 rows Ribbing. Continue in Stockinette stitch. Knit to Row 120 (124). Mark each side with a bit of contrast yarn for setting in sleeves. Knit to Row 186 (194). Bind off.

DK 905

WOMAN'S PULLOVER

SIZES: 10/12 (14/16)
 YARN: Vienna
 GRAMS:
 color 1 350 400
 color 2 50 50
 colors 3, 4, 5 - a few yards
 TENSION 5 to 7
 GAUGE: 12 sts. 16 1/2 rows = 5 cm (2")

Stockinette stitch with Norwegian Design on sleeves and embroidery on front. Bands are K1, P1 Ribbing.

FINISHING: See General Instructions. Work the embroidery on front section and use double yarn for the stem.

BEGIN HERE

- 4 rows colors 2 + 1
- 2 rows color 2
- 10 rows colors 2 + 4
- 2 rows color 2
- 6 rows colors 2 + 5
- 2 rows color 2
- 2 rows color 4
- 6 rows colors 1 + 3

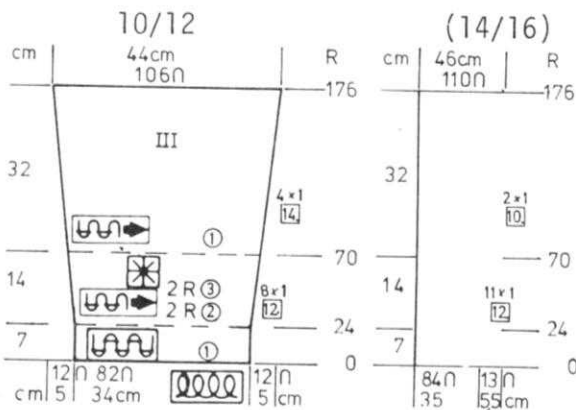

SLEEVES:

Cast on 82 (84) sts. with color 1 and work 24 rows Ribbing. Continue in Stockinette stitch and work 2 rows color 2, 2 rows color 3, then begin the Norwegian Design. ON EACH SIDE, increase 1 st. every 14th row 4x. (every 12th row 11x, every 10th row 2x) AT THE SAME TIME, after Row 70, continue in Stockinette stitch with color 1. After Row 176, bind off.

BACK & FRONT: Two sections the same.

Cast on 116 (120) sts. with color 1 and work 24 rows Ribbing. Continue in Stockinette stitch. Knit to Row 140 (144). SHAPE ARMHOLE: ON EACH SIDE, bind off 10 sts., then knit to Row 188 (194). Continue in Ribbing to Row 212 (218). Bind off.

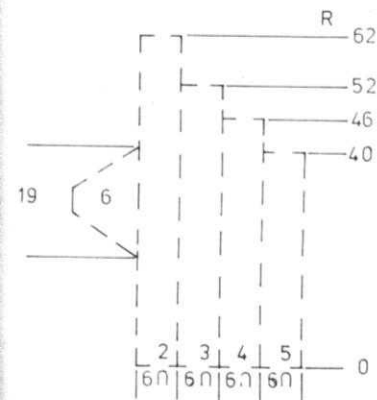
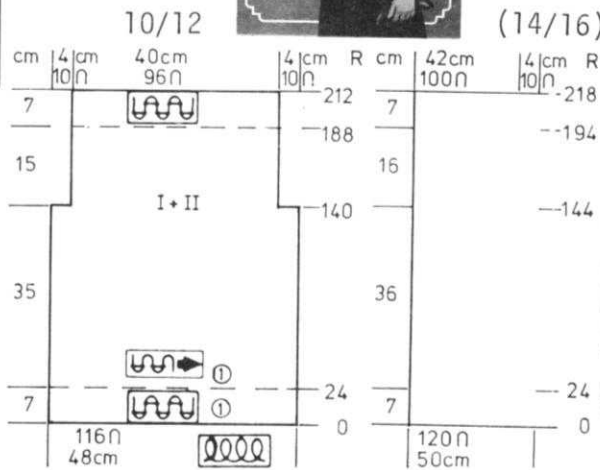
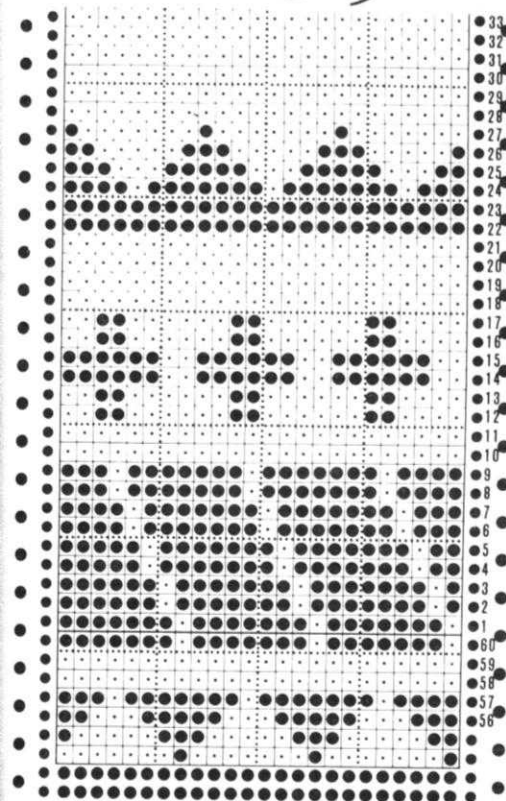

MOTIF TURN WORK UPSIDE DOWN

When you have completed the front section, work the Motif as follows: With right side facing you, pick up 6 sts. from the center of the waistband top edge - toward the LEFT. With color 2, knit 62 rows. Remove onto waste yarn. Pick up the next 6 sts. on the left and knit 52 rows with color 3 AND AT THE SAME TIME, hang the edge st. from the first stripe on every 2nd row (you are seaming the strips as you knit). See Picture. Pick up 6 more sts. on the left and with color 4, knit 46 rows, seaming as you go along on every 2nd row. Remove onto waste yarn. Pick up the next 6 sts. to the left and with color 5, knit 40 rows, seaming as you go along same as before. Remove onto waste yarn.

TRIANGLE: Use open cast on with waste yarn. Cast on 3 sts. and with color 6 work Stockinette stitch. ON THE RIGHT SIDE, ON EVERY ROW, increase 1 st. until you have 19 sts. ON THE RIGHT SIDE, ON EVERY ROW, decrease 1 st. until 3 sts. remain. Remove onto contrast waste yarn. Sew the triangle in place (see picture).

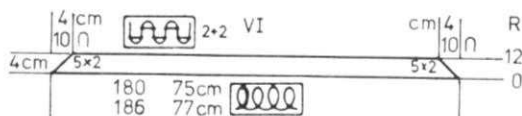
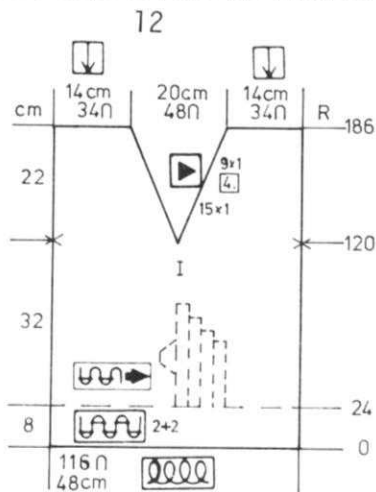

NECKBAND: VI

Cast on 180 (186) sts. and work in Ribbing. ON EACH SIDE, ON EVERY 2nd ROW, decrease 2 sts. 5x. After Row 12, bind off or remove onto waste yarn.

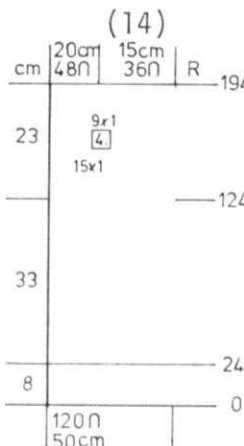

FRONT: I

Work the front the same as the back to Row 120 (124). Mark each side as you did for the back and divide in the center. Put the needles on the left into holding position and complete the right side first. *ON NECK SIDE, decrease 1 st. every 2nd row 15x, every 4th row 9x. After Row 186 (194), bind off. Bring the needles on the left into working position, knit 1 row to the left side, turn the Row Counter back to 120 (124) and complete the left half. Follow the instructions from *.

DK 906

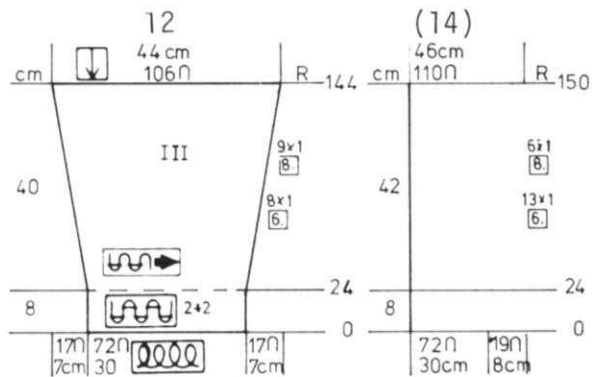

SLEEVES: III

Cast on 72 sts. and work 24 rows Ribbing.
Continue in Stockinette stitch.
ON EACH SIDE, increase 1 st. every 6th row 8x, every 8th row 9x. (every 6th row 13x, every 8th row 6x). After Row 144 (150), bind off.

DK 907

WOMAN'S PULLOVER

SIZES:	12	(14)	[16]
YARN:	Amore		
GRAMS:			
color 1	100	100	150
color 2	100	100	150
color 3	100	100	150
color 4	100	100	150
TENSION:	5 to 7		
GAUGE:	12 sts. 18 rows = 5 cm (2")		

Stockinette stitch with color stripes as shown on the Chart.
Bands are K1, P1 Ribbing.

FINISHING: See General Instructions.

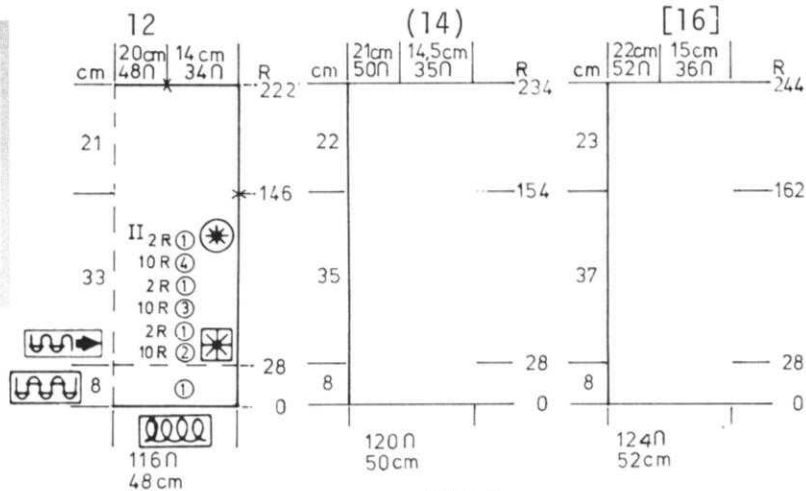

BACK: I

Cast on 116 (120) [124] sts. with color 1 and work 28 rows Ribbing. Continue in Stockinette stitch with color stripes as shown on the Chart. After Row 146 (154) [162], mark each side with bit of waste yarn for setting in the sleeves. After Row 222 (234) [244], remove each shoulder - 34 (35) [36] sts. onto contrast waste yarn, then remove the neck sts. onto waste yarn.

FRONT: I

Work the front the same as the back to Row 136 (148) [158]. Divide in the center and put the needles on the left into holding position and complete the right side first. *Mark edge after Row 146 (154) [162]. ON NECK SIDE, decrease 1 st. every 2nd row 5x, every 4th row 19x. (every 2nd row 7x, every 4th row 18x). [every 2nd row 9x, every 4th row 17x]. After Row 222 (234) [244], remove the sts. onto waste yarn. Bring the needles on the left into working position, knit 1 row to the left side, (watch stripes), turn the Row Counter back to 136 (148) [158] and complete the left half. Follow the instructions from *.

SLEEVES: III

Cast on 62 (67) [72] sts. with color 1 and work 28 rows Ribbing. Continue in Stockinette stitch with color stripes same as back and front. ON EACH SIDE, increase 1 st. every 8th row 11x, every 6th row 8x. (Same as first size). [every 8th row 15x, every 6th row 4x]. After Row 164 (168) [172], bind off or remove onto waste yarn.

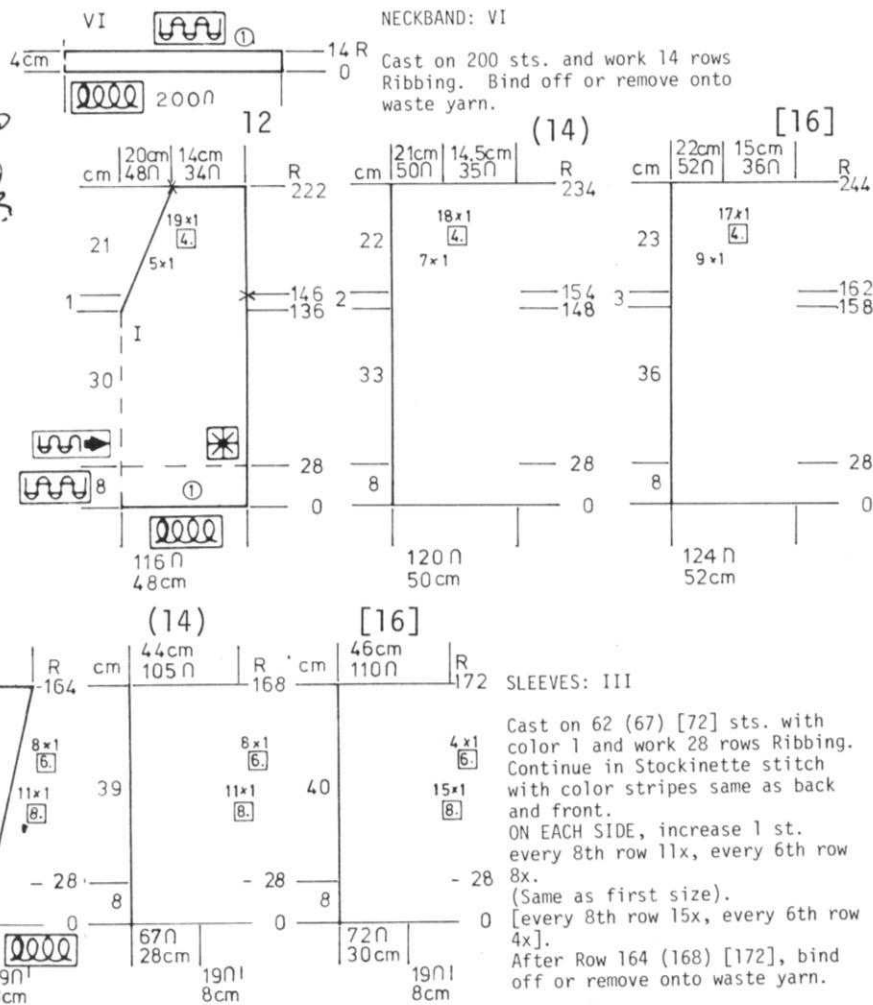

KK 908

CHILD'S DRESS

SIZES: 4 (6/8)
 YARN: Amore
 GRAMS:
 color 1 300 350
 color 2 50 50
 color 3 50 50
 TENSION: 5 to 7
 GAUGE: 14 sts. 20 rows = 5 cm (2")

Stockinette stitch and a Norwegian Design. Punch your own Card. The Design on sleeve is isolated. Bands are Stockinette stitch.

FINISHING: Sew all seams, leave Cuff open. Work 2 rows single crochet down back and sleeve openings, making buttonholes on 2nd row. Sew buttons in place. Make a cord with color 2 over 3 needles and sew at waist. Make tassels for ends of cord. Sew on sequins as shown in picture if you like them.



COLLAR:

Cast on 72 sts. with color 2. Work Stockinette stitch, changing the Tensions every 2 rows - from tension 5 to 3 then 3 to 5. After Row 12, remove onto contrast waste yarn.

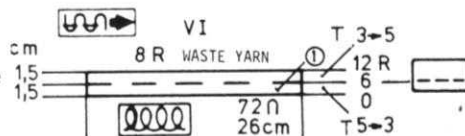

FRONT BODICE: I

Work the front the same as the back to Row 32 (36). Bind off the center 14 sts., put the needles on the left into holding position and complete the right side first.
 *ON NECK SIDE, bind off 7 sts. 1x, 3 sts. 1x. (Same as first size). After Row 56 (60), SHAPE SHOULDER same as the back. Bring the needles on the left into working position, knit 1 row to the left side, turn the Row Counter back to 32 (36) and complete the left half. Follow the instructions from *

BACK BODICE: II

Hang 1 section of skirt back onto the machine, doubling the sts. across - 82 (90) sts. Work the Norwegian Design with colors 1 and 2. AT THE SAME TIME, after Row 8, SHAPE ARMHOLE: ON EACH SIDE, bind off 5 sts. 1x, 2 sts. 1x, 1 st. 1x for both sizes. When Norwegian Design is completed continue with Stockinette stitch and color 1. After Row 32 (36), divide in the center, put the needles on the left into holding position and complete the right side first.
 Knit to Row 56 (60). SHAPE NECK AND SHOULDER: Bind off 17 sts. for NECK and for SHOULDER, bind off 4 sts. 4x. (5 sts. 4x). Bring the needles on the left into working position, knit 1 row to the left side, turn the Row Counter back to 32 (36) and complete the left half. Follow the instructions from.

SKIRT: Make 2 sections the same.

Cast on 164 (180) sts. with color 1 and with lower tension, knit 24 rows Stockinette stitch. Hang the hem. Work the Norwegian Design to Row 64 with colors 2 & 3. Continue in Stockinette stitch with color 1 to Row 152 (192). Remove the sts. onto contrast waste yarn.

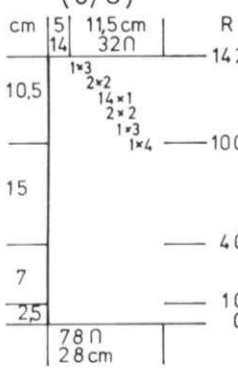
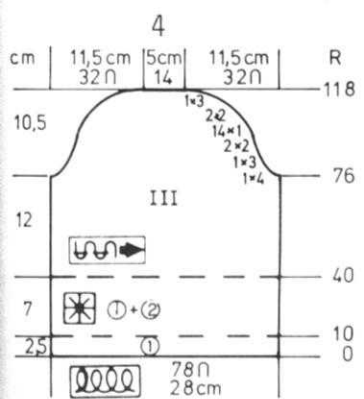
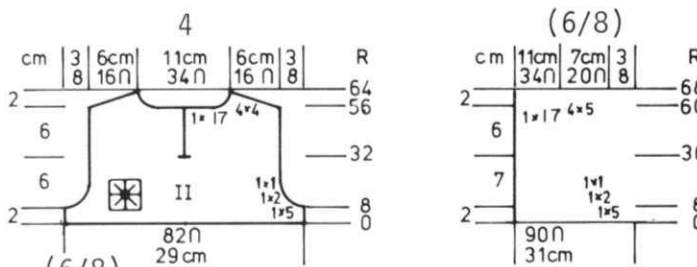
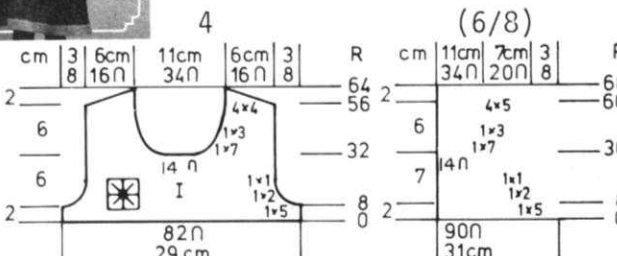

SLEEVES: III

With contrast waste yarn, cast on 78 sts. After knitting 8 to 10 rows, change to color 1 and put Counter at 0. Work Stockinette stitch. After Row 10, continue in the Norwegian Design - ISOLATED in the center of sleeve - or you can simply knit the design across. Use Colors 1 and 2. After Row 40, continue in Stockinette stitch with color 1. Knit to Row 76 (100). SHAPE CAP: For BOTH sizes, ON EACH SIDE, bind off 4 sts. 1x, 3 sts. 1x, 2 sts. 2x, 1 st. 14x, 2 sts. 2x, 3 sts. 1. Bind off the remaining sts.

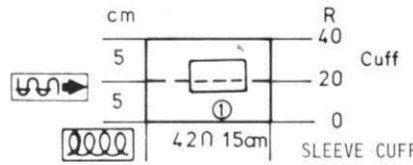

Hang the open sts. of the sleeve back onto the machine, decreasing to 42 sts. (2 sts. on each needle). With color 1, work Stockinette stitch to Row 40, hang the hem and bind off.

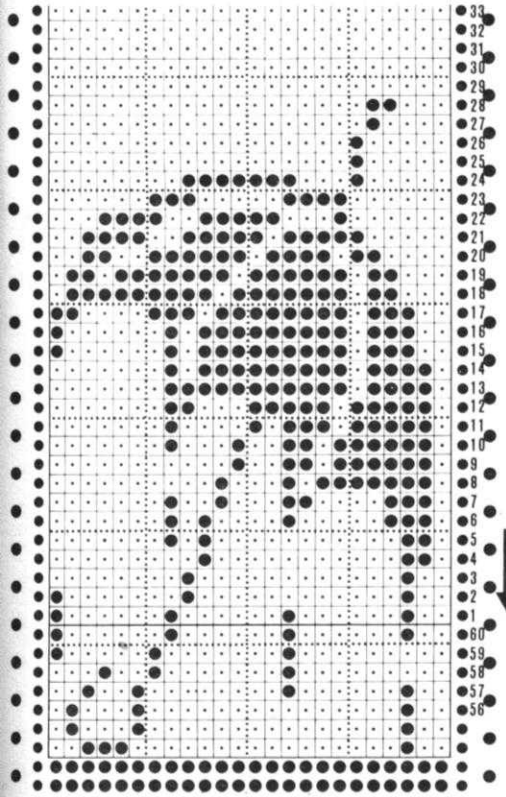
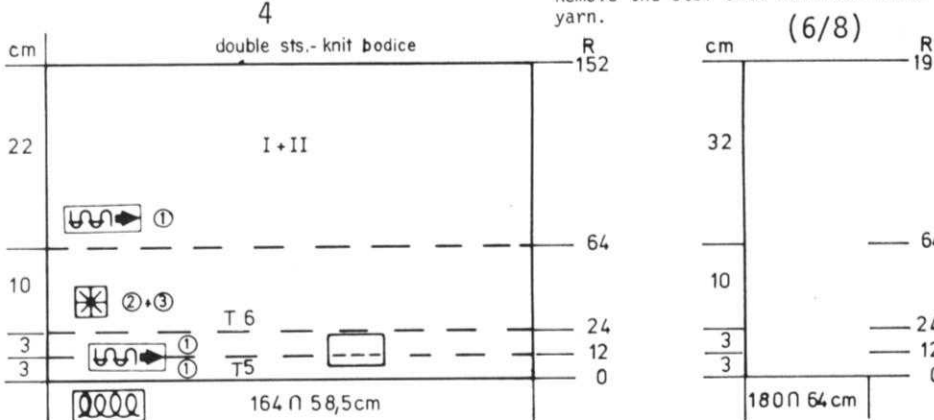

DK 909



WOMAN'S PULLOVER

SIZES: 8/10 (12/14)

YARN: Micaela

GRAMS:
color 1 300 350
color 2 300 350

Small amounts of colors 3 & 4

TENSION: 6 or 7

GAUGE: 16 sts. 19 rows = 5 cm (2")

Norwegian Designs with color stripes.
You will need to punch Card A and use
Card No. 1 (840, 830, 820 machine
owners) for PATTERN B.

Bands are K2, P2 (or K1, P1) Ribbing.

FINISHING: See General Instructions.

FRONT: I

The front is worked the same as
the back to Row 164 (170).
ON THE LEFT, bind off 105 (111) sts.
then ON THE LEFT, decrease 1 st.
ALTERNATELY every 2nd row then every
4th row 15x in all.
After Row 240 (246) work the color
stripes in Stockinette stitch same
as the back section.
After Row 254 (260), bind off.

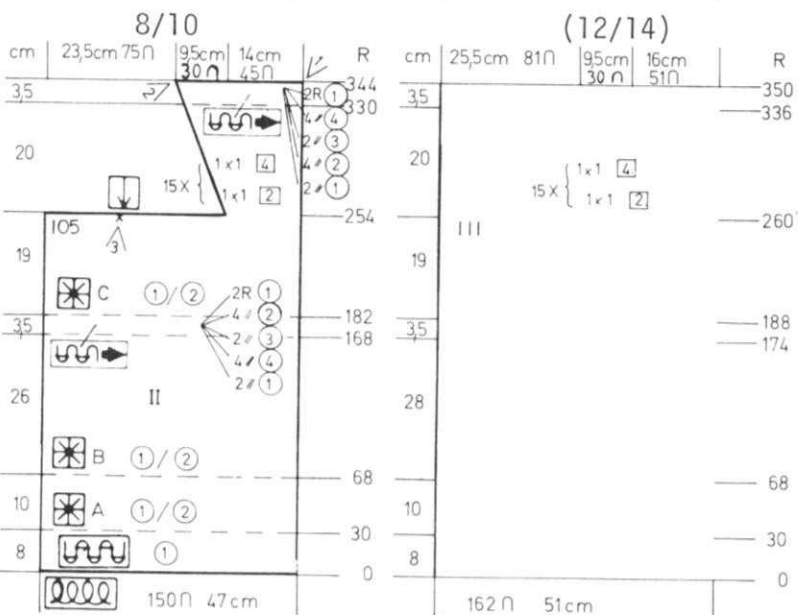
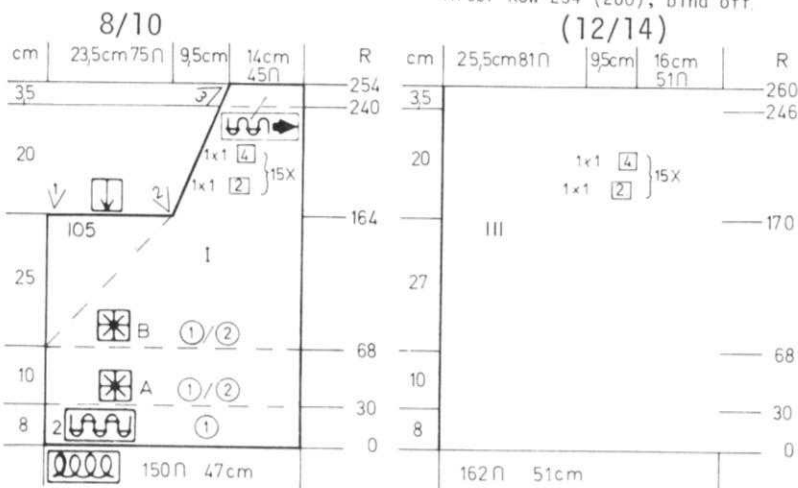

CUFF:

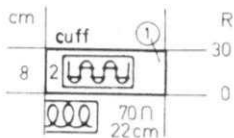

Hang the open sts. of the sleeve
back onto machine, decreasing to
70 sts. (2 sts. on each needle).
With color 1, knit 1 row then
transfer the sts. to Ribber and
work 30 rows Ribbing.
Bind off.

BACK and LEFT FRONT: II

Cast on 150 (162) sts. with color 1
and work 30 rows Ribbing.
Transfer the ribber sts. to main
machine and work PATTERN A with
color 1 & 2, to Row 68, then continue
with Pattern B with color 1 & 2 to
Row 168 (174).
Continue with Stockinette stitch and
color stripes of
2 rows color 1, 4 rows color 4,
2 rows color 3, 4 rows color 2
2 rows color 1.
After Row 182 (188), continue with
Pattern C using colors 1 & 2.
After Row 254 (260), ON THE LEFT,
bind off 105 (111) sts. then increase
1 st. ALTERNATELY every 2nd row then
every 4th row 15x in all.
After Row 330 (336) Continue in
Color stripes and Stockinette st.
of 2 rows color 1, 4 rows color 2,
2 rows color 3, 4 rows color 4,
2 rows color 1.
After Row 344 (350), bind off.

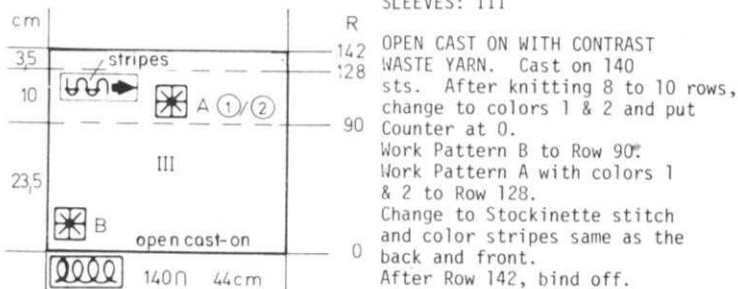

SLEEVES: III

OPEN CAST ON WITH CONTRAST
WASTE YARN. Cast on 140
sts. After knitting 8 to 10 rows,
change to colors 1 & 2 and put
Counter at 0.
Work Pattern B to Row 90.
Work Pattern A with colors 1
& 2 to Row 128.
Change to Stockinette stitch
and color stripes same as the
back and front.
After Row 142, bind off.

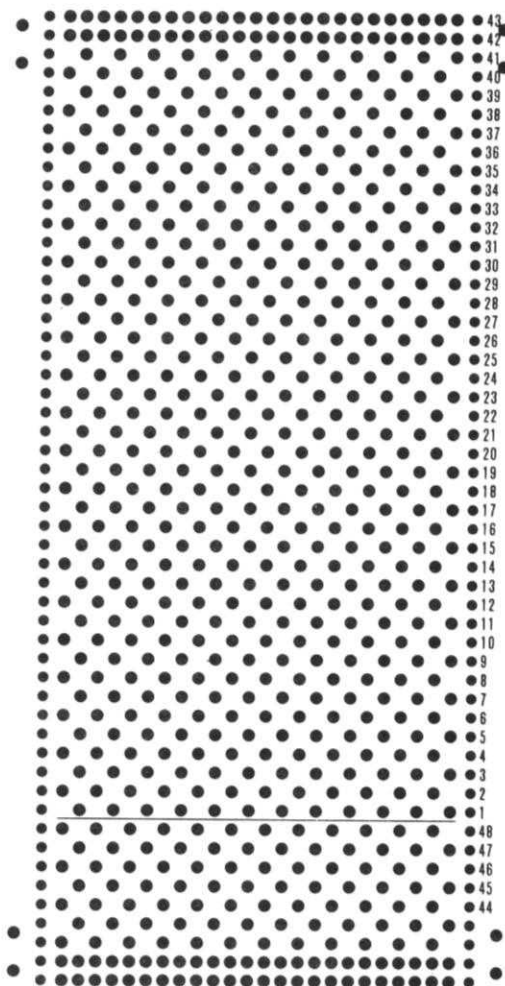

B



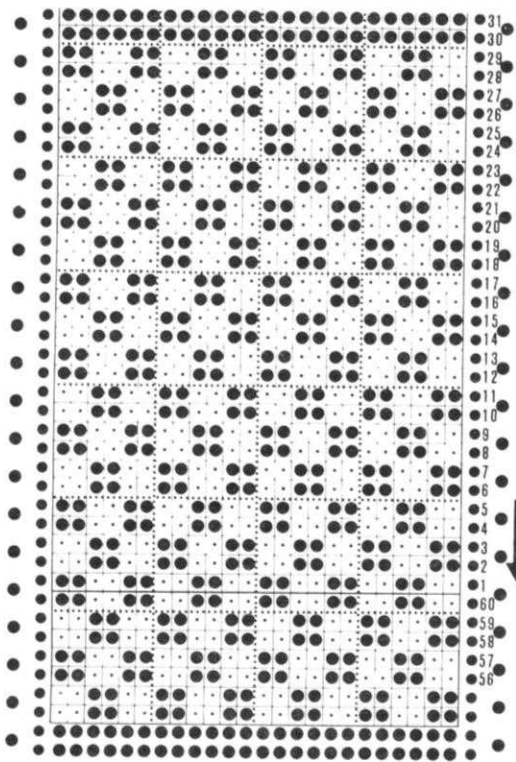

C



MASON JAR CAP COVERS

YARN: Amore
 GRAMS: 50 White (Will make 18
 50 Red to 20)

TENSION: 3
 GAUGE: Not important

PATTERN: Norwegian (Fairisle) technique.

FINISHING:

Purchase Mason Jars in 1/2 pint size for small candies or gifts - or you can use pint size or quart size for larger gifts.
 Cut 2 very small Holly leaves out of green felt and attach anywhere on the knitted cover, anchoring the leaves with a red sequin and bead.
 Mark a circle around a Mason Jar seal on a 3x5 card (or any very thin cardboard). Cut around the circle.
 Cut off one of the knitted squares.
 Put a wad of cotton in the center of the card and cover with the knitted square then staple closely around.
 Cut off the excess knitting around the circle. Set into outer ring of jar and cover the bottom with the seal.
 You can put a bit of rubber cement around the edges of the seal to make it stay put.

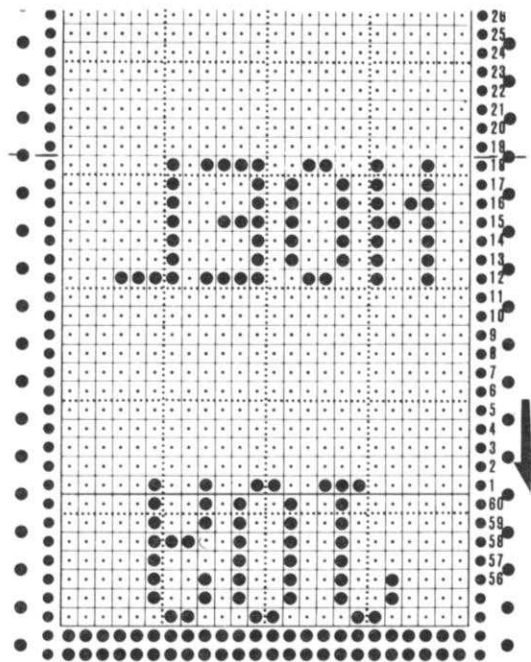

With contrast waste yarn, cast on 30 sts. over needles 14 on the left of 0 through 15 on the right of 0. Knit 10 rows waste yarn, then change to white and put Counter at 0.

Knit 13 rows ending with Carriage on the left side. Insert Card, set on STOP: Set Cam to KC, knit 1 row to right (to set the needles) Put Card on GO and push in MC Button. Attach red yarn and knit the word JOY.

When completed and the needles are all in work, stop Card, remove red yarn and with white only knit 14 rows Stockinette stitch.

With contrast waste yarn, knit 10 rows.

NOEL: Knit in the same manner as JOY. (You can make the covers in strips then cut them apart).

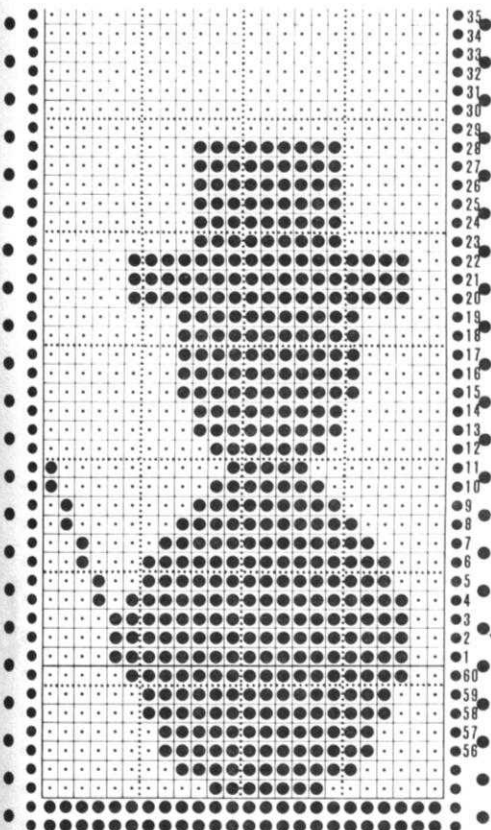

A



PILLOW

YARN: Euro Sport
GRAMS:
 color 1 100 - Red
 color 2 100 - White
TENSION: 8 or 9
GAUGE: 14 sts. 18 rows = 5 cm (2")

A Norwegian Design. Punch your own Card.

FINISHING: Press gently and smooth edges. Slip Stitch crochet the open sts. together on the wrong side then remove waste yarn. Cut eyes, nose and mouth from black felt (or you can embroider the face). Sew 1 side then stuff with polyester fiber fill and close opening. Make trims as follows: Use a 10 inch box top and wind yarn around it 30 times. Cut only 1 end. Fold in half and tie in the center then sew onto pillow. Make 4 in red and 2 in white. Sew one red one to each side of top of pillow and one red one to each side of lower ends of pillow then sew then white ones in center of the lower edge. Braid the two white ones and two lower red ones and tie and trim. Puff up the upper red ones and tie then trim.

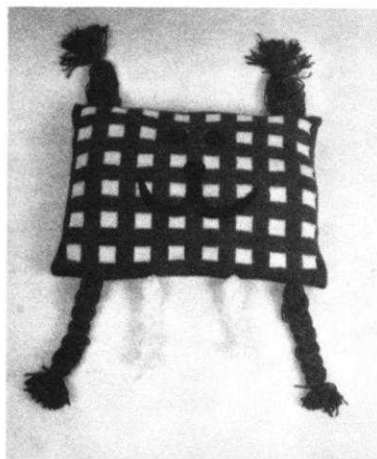

For correct Pattern set-up, cast on from needle 48 on the left through 54 on the right. (102 sts.). Begin and end with contrast waste yarn.

*Start with 8 rows red but set Card on STOP, machine on KC BEFORE knitting the 8th row from left to right. Put Card on GO, push in MC Button and work card with red and white. Each time you come to the plain red rows, it is a good idea to remove the white from B Feeder.

Knit 104 rows (ending with plain red rows). STOP CARD. Set Row Counter to 0 and REPEAT from * for second half. Remove onto contrast waste yarn.

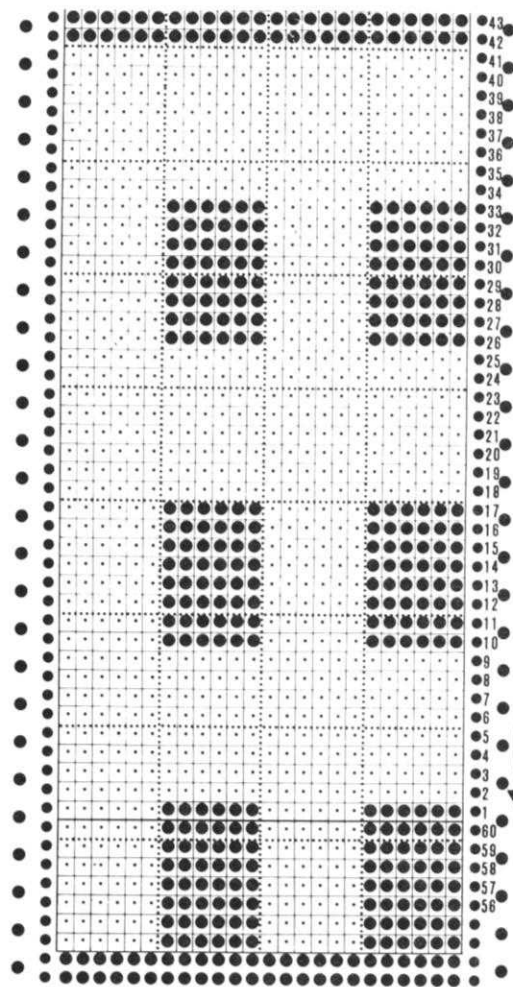

DRESSY SCARF

YARN: Micaela
GRAMS: 100 (approx.)
TENSION: 9 or 10
GAUGE: Not important

An Eyelet Design with needles out of work. Punch your own Card.

FINISHING: Slip stitch crochet through the open stitches at each end, working a chain stitch between each space. Remove the waste yarn. Wind yarn around a 6 inch cardboard then cut only one end. Use 3 or 4 strands, fold in half to make fringe. Put fringe into every large space.

Bring into working position, needle 27 on the LEFT of 0, then all needles to the right through needle 32 on the right of 0.

Beginning with the first needle to the RIGHT of 0, put this then every 3rd needle back to the out of work position all the way across on each side.

With contrast waste yarn, cast on over the remaining 40 needles. Knit 10 rows, then change to Venetia and put Counter at 0.

Work in Lace Pattern (knit 2 rows before using Lace Carriage) to Row 500 (or for as long as you wish). Work 10 rows Stockinette stitch with waste yarn. Remove the work from the machine.

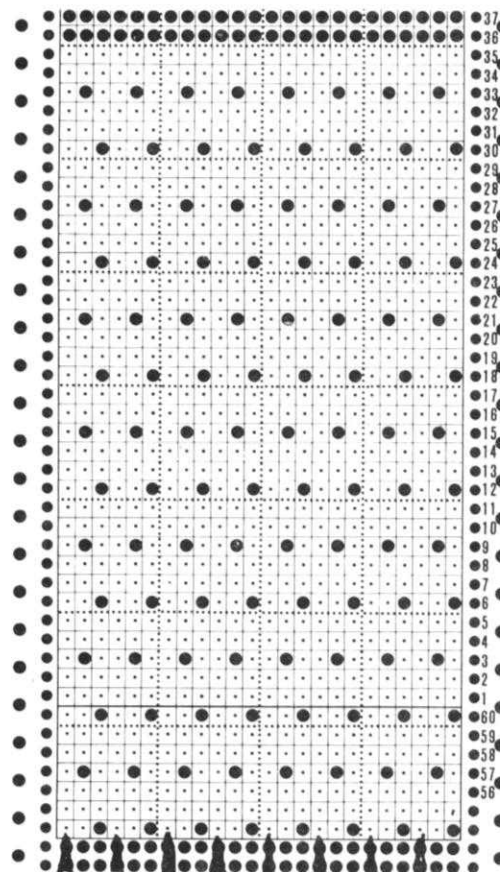

KNITTING NEWS

PRACTICAL KNITTING HINTS

HANG OPEN STITCHES OF SHOULDERS AND BIND OFF

The Pullover DK 907, tells you to remove the shoulder sts. onto waste yarn. An easy way to seam the shoulder is to hang the open stitches onto the machine and then bind them off in this manner.

Hang the back shoulder with knit side (OR RIGHT SIDE) facing you onto the machine, then push the sts. so that they go behind the latches.

Now hang the front shoulder sts. with purl side (OR WRONG SIDE) facing you onto these same needles and leave them in the hooks of the needles.

Pull each front shoulder stitch through the back shoulder stitches, then bind off the crochet method.

COMPUKNIT KH 910 ELECTRONIC KNITTING MACHINE

Simply stated... the COMPUKNIT KH 910 is the most advanced Home Knitting Machine on the face of the earth...

Three years in the designing stage and more than a year of exhaustive prototype testing before proceeding with production... Now each and every single machine undergoes several hours of testing before receiving a stamp of approval.

When you take delivery of a KH 910 COMPUKNIT, you can be sure of its efficiency and the greatest versatility of any home knitting machine ever made. Your machine will carry the approval of the Underwriters Laboratory... Its computer will not cease to function when an aircraft flies over your house or a diesel truck passes your door... A built in noise barrier eliminates those possibilities.

When you program your design on a COMPUKNIT, it is not cancelled out if there is a power cut or if you pull the plug from your 110 volt electricity outlet... Your COMPUKNIT has a memory unit that will retain the program for many months, even without a power supply... There are no unsightly cables attached to the carriage of the KH 910 and its transformer (it reduces 110 volts to 12 volts) is built in.

The more we use the COMPUKNIT, the more we are amazed at its capabilities. We have been importing knitting machines for more than a quarter of a century. During that time we have seen the introduction of many brands and styles but never have we seen one such giant step forward as is made with the COMPUKNIT KH 910. Never have we been so excited over any single knitting machine... Would you believe we are producing single motif designs over the full width (200 needles) of the COMPUKNIT needle bed...? and every newspaper and every magazine we look at becomes a source for pictures and designs that can be reproduced on the incredible COMPUKNIT KH 910.

As a reader of KNITTING MAGAZINE, you are almost certain to own a brand name knitting machine and like most knitting machine owners, you see no point in trading up unless there is some revolutionary change in knitting machine function and design. Well, this is it....!! The all new fantastic, versatile yet easy to use COMPUKNIT KH 910 is here and we are offering tremendous trade-ins.

Tell us the brand, model and condition of your present machine and you will be amazed at our generous trade-in offer... and when you use your own COMPUKNIT, you will agree... There is no other knitting machine in the world to compare with it.

**two new
books**

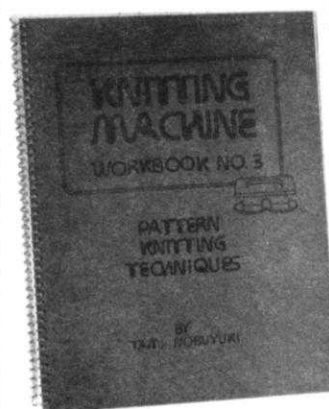

NEW BOOK FROM TAMI NOBUYUKI

Here's No. 3 in the excellent series of books written by Tami... No. 1 is her Basic Knitting Techniques book... No. 2 is Ribbing Techniques... and the new No. 3 is Pattern Knitting Techniques. We highly recommend this new book. It covers Pattern Stitch work with Punch Card machines, with Push Button machines and with machines that require manual selection. It covers the punching of your own cards including lace cards. It has a very detailed chapter on the preparation and shaping of a garment, and another on the new and fascinating picture weaving technique that Tami has developed. There are lots of worthwhile Tips and Techniques. The book is well worth its price of \$16.95. You can order direct from KNITTING, 1128 Crenshaw Blvd, Los Angeles, Calif. 90019. California residents add \$1.02 Sales Tax. The mailing costs are \$1.50.

NEW BOOK OF LACE TOPS AND SKIRTS

Here's a marvelous new book with 8 gorgeous lace outfits, all with stunning permanently pleated skirts. Although instructions are in Japanese, all measurements are in centimeters and all punch cards are illustrated so that you can punch your own. The garments can all be made on KH 840, KH 830 and KH 820 knitting machines. The low price of the book is \$3.95 (Order direct from KNITTING) California residents add 24 cents Sales Tax. Mailing costs are 40 cents.

DISCOUNTED YARN KITS FOR THIS ISSUE

The Yarn Kits for this issue of KNITTING MAGAZINE are available at special discounts to our subscribers and the prices are only good until the next issue of the magazine. Be sure to check the colors available listed at the end of this NEWS LETTER and make certain to give alternate colors.

DK 889 - Yarn: Vienna
 SIZES: 10 (12) [14]
 Regular Price \$59.40 \$67.50 \$70.30
 Sale Price 47.52 54.00 56.24
 Shipping costs 2.50 2.50 2.50

DK 890 - Yarn: Vienna
 SIZES: 10/12 (14/16)
 Regular Price \$21.60 \$24.30
 Sale Price 17.28 19.44
 Shipping costs 1.85 1.85

DK 891 - Yarn: Fortissima
 SIZES: 12 (16)
 Regular Price \$30.96 \$33.54
 Sale Price 24.77 26.83
 Shipping costs 1.85 1.85

DK 892 - Yarn: Boucle
 No. Kit Available

HP 893 - Yarn: Fortissima
 SIZES: 38/40
 Regular Price \$28.38
 Sale Price 22.70
 Shipping costs 1.85

HP 894 - Yarn: Fortissima
 SIZES: 38 (40)
 Regular Price \$28.38 \$30.96
 Sale Price 22.70 24.77
 Shipping costs 1.85 1.85

HP 895 - Yarn: Fortissima
 SIZES: 36/38 (40/42)
 Regular Price \$30.96 \$33.54
 Sale Price 24.77 26.83
 Shipping costs 1.85 1.85

DK 896 - Yarn: Micaela
 SIZES: 8/10 (12/14) [16/18]
 Regular Price \$25.19 \$27.49 \$27.49
 Sale Price 20.15 21.99 21.99
 Shipping costs 1.85 1.85 1.85

DK 897 - Yarn: Amore
 SIZES: 10.12 (14/16) [18/20]
 Regular Price \$16.73 \$16.73 \$19.12
 Sale Price 13.38 13.38 15.30
 Shipping costs 1.85 1.85 1.85

KK 898 - Yarn: Pingouin Oued
 SIZES: 3 Mo. (6 Mo.) [9 Mo.]
 No Kit Available

KK 899 - Yarn: Fortissima
 SIZES: 12 Mo. (18 Mo.)
 Regular Price \$10.32 \$10.32
 Sale Price 8.26 8.26
 Shipping costs 1.85 1.85

KK 900 - Yarn: Pingouin Oued
 No Kit Available

DK 901 - Yarn: Amore
 SIZES: 10 to 16
 Regular Price \$19.12
 Sale Price 15.30
 Shipping costs 1.85

DK 902 - Yarn: Pingouin Oued
 No Kit Available

HP 903 - Yarn: Fortissima
 SIZES: 38 (40)
 Regular Price \$25.80 \$28.38
 Sale Price 20.64 22.70
 Shipping costs 1.85 1.85

DK 904 - Yarn: Vienna
 SIZES: 1 Size to fit all
 Regular Price \$32.40
 Sale Price \$25.92
 Shipping costs 1.85

DK 905 - Yarn: Vienna
 SIZES: 10/12 (14/16)
 Regular Price \$21.60 \$24.30
 Sale Price 17.28 19.44
 Shipping costs 1.85 1.85

DK 906 - Yarn: Vienna
 SIZES: 12 (14)
 Regular Price \$21.60 \$21.60
 Sale Price 17.28 17.28
 Shipping costs 1.85 1.85

DK 907 - Yarn: Amore
 SIZES: 12 (14) [16]
 Regular Price \$19.12 \$19.12 \$28.69
 Sale Price 15.30 15.30 22.95
 Shipping costs 1.85 1.85 1.85

KK 908 - Yarn - Amore
 SIZES: 4 (6/8)
 Regular Price \$19.12 \$21.51
 Sale Price 15.30 17.21
 Shipping costs 1.85 1.85

DK 909 - Yarn - Micaela
 SIZES: 8/10 (12/14)
 Regular Price \$27.48 \$32.06
 Sale Price 21.98 25.65
 Shipping costs 1.85 1.85

Mason Jar Covers - Yarn: Amore
 Regular Price \$ 4.79
 Sale Price 3.83
 Shipping costs 1.00

Pillow - Yarn: Euro Sport
 Regular Price \$ 7.00
 Sale Price 5.60
 Shipping costs 1.25

Dressy Scarf - Yarn: Vienna
 Regular Price \$ 5.40
 Sale Price 4.32
 Shipping costs 1.00

CHOOSE YOUR YARN KITS FROM THE FOLLOWING COLORS

AMORE . . . White, Dark Green, Pink, Rust, Red, Coral, Yellow, Rose, Beige, Med.Blue, Navy, Turquoise, Jade Green, Plum, Lilac, Dk.Grey, Med.Grey, Orange Tweed, Beige Tweed, Ivory, Brown, Wine Red

FORTISSIMA . . White, Black, Tan, Dk.Green, Grey, Beige Tweed, Green Tweed, Blue Tweed, Turquoise

MICAELA . . . White, Black, Turquoise, Tan Brown, Orange, Peach, Sea Green, Grass Green, Yellow

VIENNA . . . White, Black, Lt. Green, Lilac, Ice Blue, Peach, Coral, Yellow, Brown, Moss, Beige, Rust, Med. Blue, Teal Blue, Red, Burgundy, Plum, Gold, Aqua, Peacock Blue



HP 893

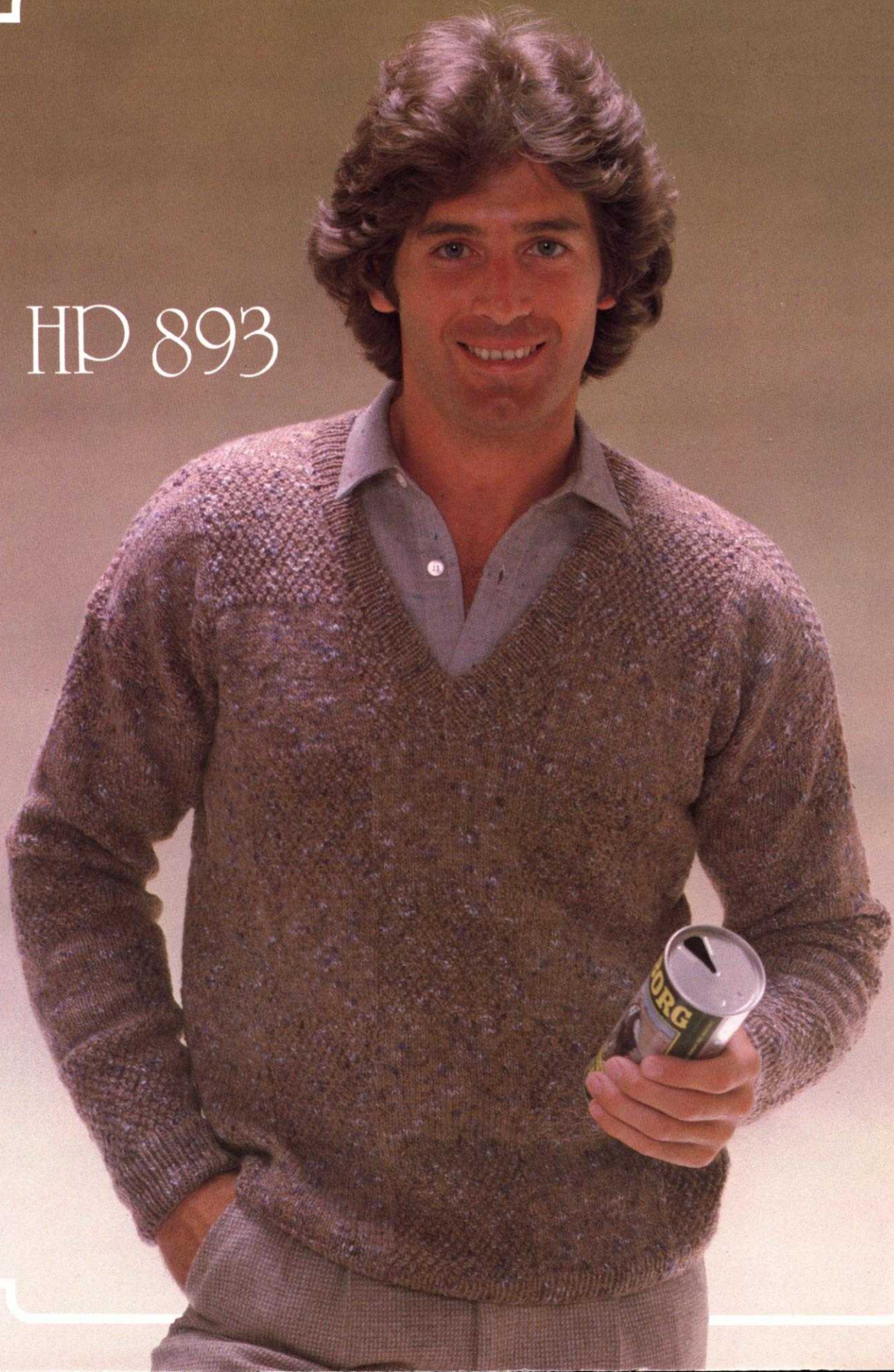

DK 907

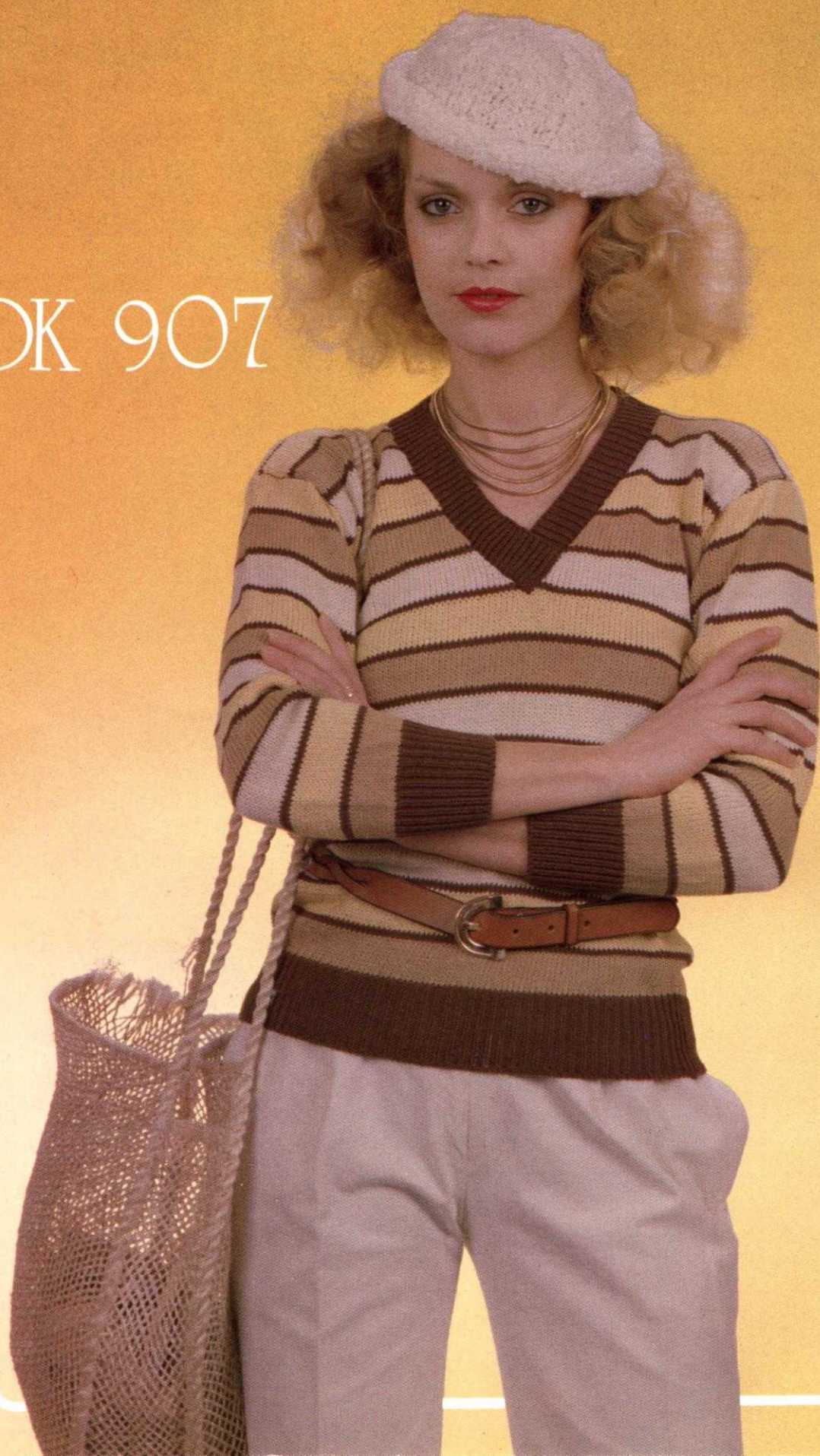

DK 906



HP 903



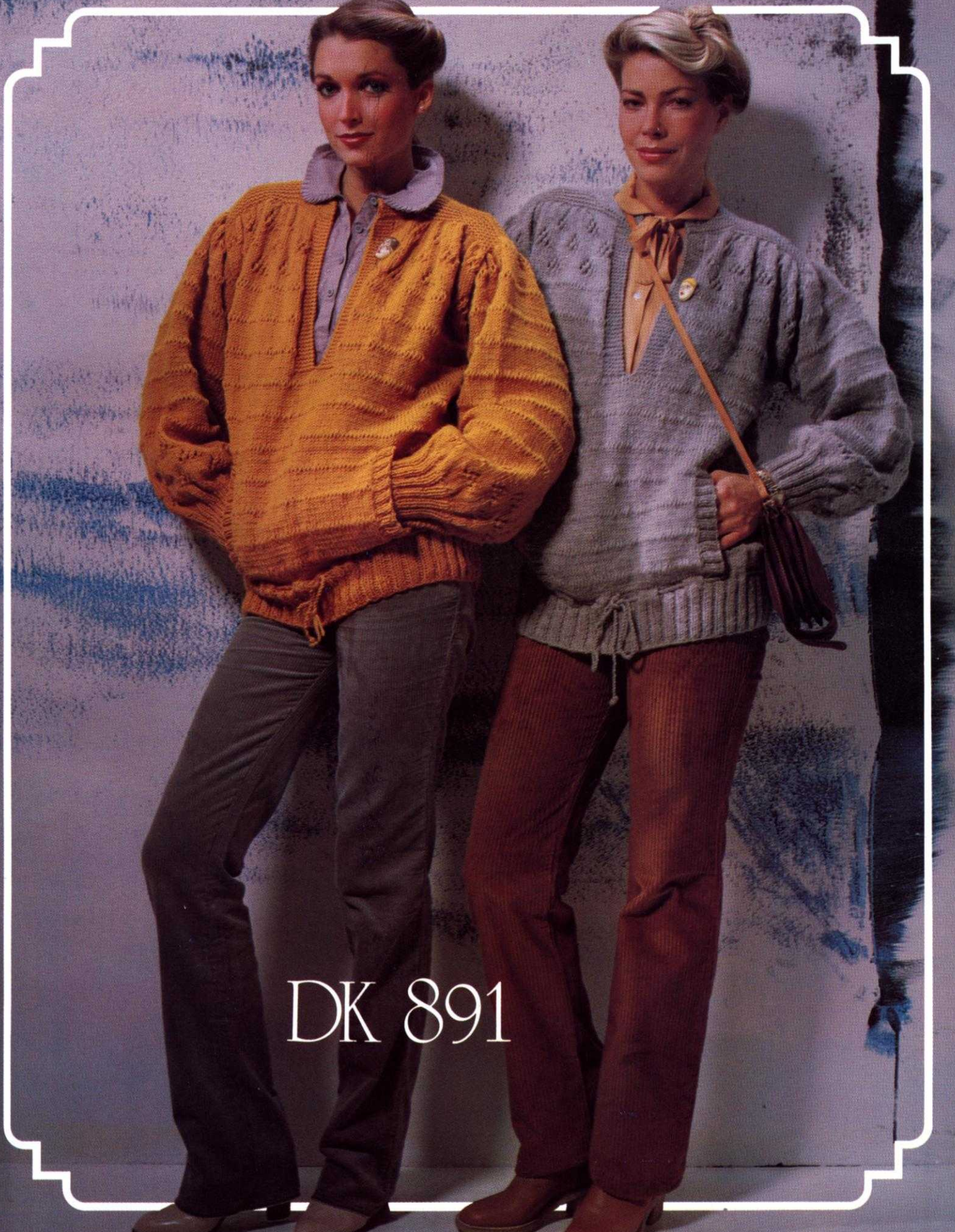

DK 891

HP 895



KK 908



KK 899



KK 898



HP 894

