

16-3

knitking

magazine

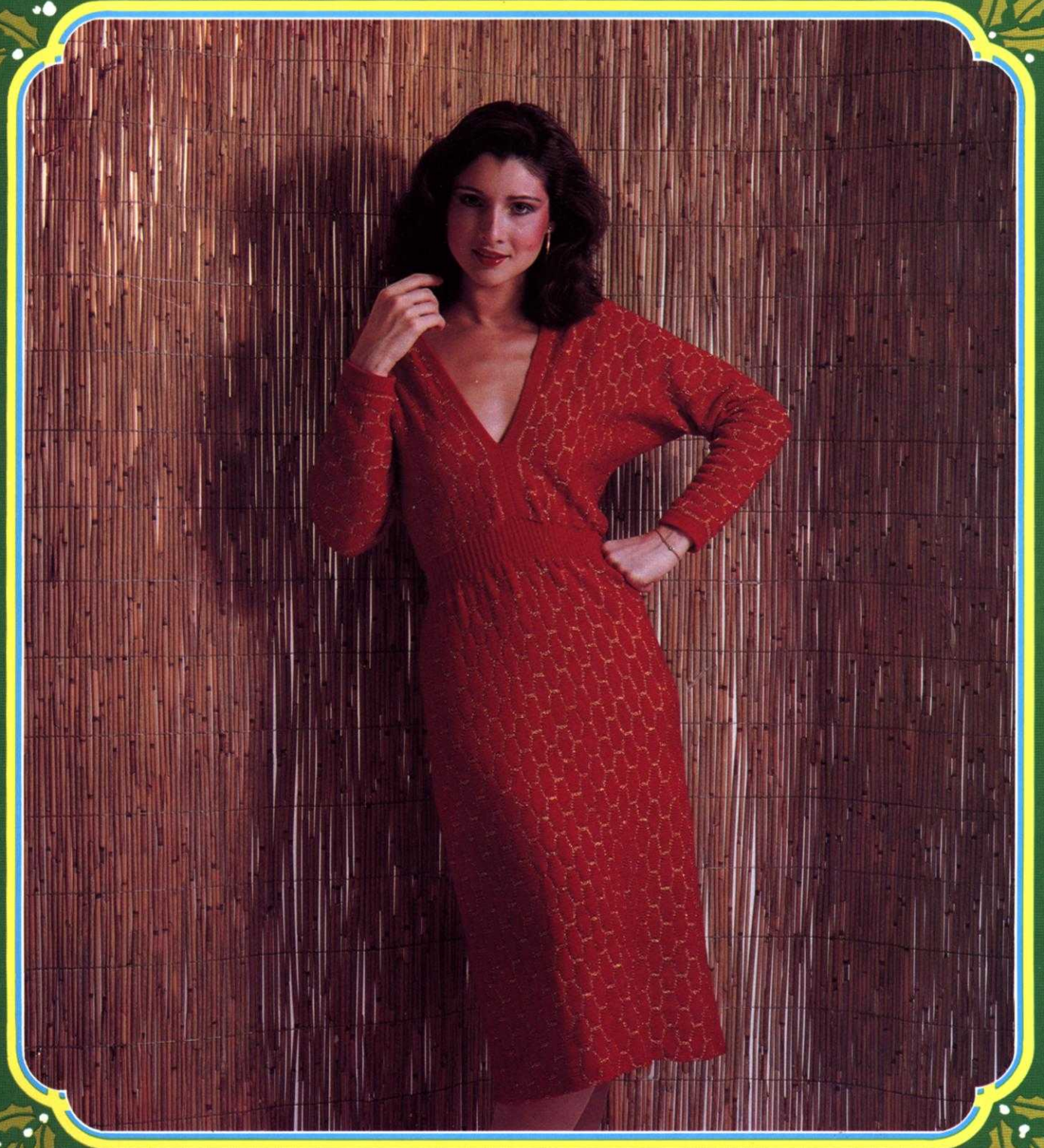

A woman with her hair in a braid, wearing a pink scarf and a dark purple and pink striped sweater with a diamond pattern on the chest. She is holding a glass of fruit. The background is a blurred outdoor setting. The image is framed by a white decorative border with floral motifs at the corners.

DK935

DK923

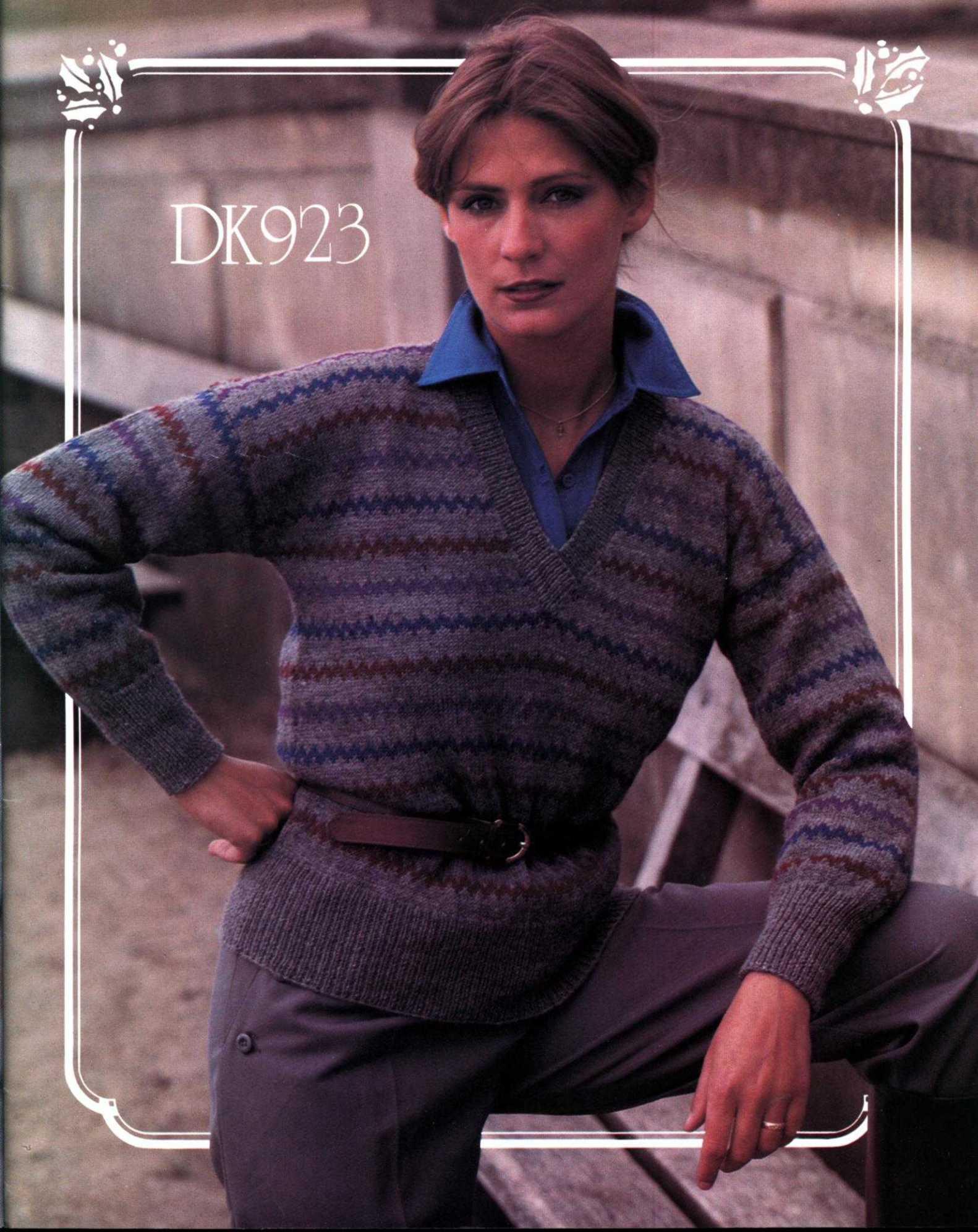



DK 916



DK 918

A woman with long blonde hair styled in a thick braid is smiling and looking to her right. She is wearing a dark brown knit vest over a long-sleeved top with a white lace-like pattern. The vest has a ruffled edge on the right side. She is also wearing brown pants. The background consists of white curtains with dark vertical stripes. The entire image is framed by a white decorative border with floral motifs at the corners.

DK 912

A woman with her hair in a braid is sitting on a window ledge. She is wearing a maroon knit sweater with a teal and maroon patterned design and matching maroon pants. She is holding a teal and maroon bag. The background shows a window with a view of a building.

DK 934

DK919



DK924





DK 915

DK 914

VOLUME 16, NO. 3

knitking

magazine

TABLE OF CONTENTS - VOLUME 16, NO. 3

KK 910	Child's Pullover	14
DK 911	Woman's Coat	15
DK 912	Woman's Pullover	15
DK 913	Woman's 2-Piece Suit	16
DK 914	Woman's 3-Piece Suit	19
DK 915	Woman's Dress	20
DK 916	Woman's Pullover with Round Yoke	21
DK 919	Woman's Twinset	24
DK 920	Woman's Jogging Suit	26
HP 921	Man's Jacket	27
KK 922	Child's Pullover	28
DK 923	Woman's Pullover	29
DK 924	Teenager's Pullover	30
DK 925	Woman's Skirt & Pullover	32
HP 926	Man's Pullover	33
DK 931	Woman's Pullover	34
DK 932	Woman's Pullover	35
DK 933	Woman's Pullover	36
DK 934	Woman's Pullover	37
DK 935	Woman's Pullover	38
KK 936	Child's Pullover	39
KK 937	Child's Cardigan	40
	Lace Collar & Cuffs	41
	Slippers	42

Publisher: KNITKING CORPORATION, 1128 Crenshaw Blvd., Los Angeles, Calif. 90019. Telephone: (213) 938-2079. Published bi-monthly. Subscriptions: USA — \$15.00 annually, single copies \$4.00; Canada — \$18.00; other parts of the world — \$20.00. The entire contents of KNITKING MAGAZINE are copyright and must not be reproduced in any shape or form without the express permission, in writing of the publisher. ©COPYRIGHT 1980 by KNITKING CORPORATION.

editorial

As we write this Editorial, 1980 is speedily drawing to a close... It has been an eventful and exciting year for KNITKING... and, we take the opportunity to thank our loyal readers and machine customers for their continued support... You are again largely responsible for the fact that KNITKING set a new all time sales record in 1980... Our long established reputation for complete and speedy customer service is still maintained and is, in fact, growing as more and more customers, dissatisfied with the services provided by other knitting machine companies, are switching to KNITKING.

Our truly competitive prices for knitting machines, accessories and yarns are resulting in much word of mouth advertising and we especially thank the many customers who tell their knitting friends about KNITKING. The major event of 1980 was, without a doubt, the introduction of the fantastic 'State of the Art' KH 910 COMPUKNIT electronic knitting machine...the computerized knitter that is in a class of its own... We hope that everyone of our knitting machine owners will be fortunate enough to step up to a COMPUKNIT in 1981.

Another event of great importance is the printing of a special edition of KNITKING MAGAZINE for the United Kingdom... We are receiving numerous letters from readers there, telling us how much they love KNITKING MAGAZINE and how superior it is to anything else available.

Regular readers will notice some small changes in the format of KNITKING MAGAZINE, this issue... There will be more forthcoming in future editions as we continue to improve our format.

















Be sure to watch out for the next edition... we think its cover picture is the finest we have ever had... the patterns in the issue for men, women and children are designed to satisfy all tastes.



Everybody at KNITKING joins in wishing all of our friends a happy and prosperous 1981.





Pattern Symbols

Knitting – Chart Symbols

- () Size Symbols (2nd Size)
- < > 3rd Size
- ① Color Number
-  Cast on
-  Stitch
-  Row
-  Hem
-  Bind off
-  Stockinette stitch – worn on the Knit side.
-  Stockinette stitch – worn on the Purl side.
-  Knit 1, Purl 1 Ribbing
-  Ribbing Pattern – worn on the Knit side.
-  Ribbing Pattern – worn on the Purl side.
-  Closed Dart
-  Open Dart
-  Put on a stitch holder
-  Reverse 1 section
-  On every other needle
-  Number of Rows between Shapings. Make increase (or decrease) FIRST, then knit 4 rows. For example: 3 x 1  means decrease (or increase) 1 st., knit 4 rows; decrease 1 st., knit 4 rows; decrease 1 st., knit 4 rows; decrease 1 st., knit 4 rows. All decreasing (or increasing) without row numbers as shown must be shaped on every 2nd row.

-  Increase
-  Increase 2 sts. With a transfer tool, move the sts. over the left (or right) leaving 2 empty needles at the point of increase. At the increase point, move 1 st. to the left, (or right) so that there is an empty needles on each side of a stitch. On each side of the center stitch, pick up a stitch from the row below and hang it onto the empty needle.





-  3 stitches on 1 needle. The 1st and 3rd stitch in a group of 3 has been hung on the 2nd or center needle.
-  Short Row increase or decrease; for instance on a flared skirt knitted sideways.

-  Pattern Stitch
-  Pattern Stitch – worn on the Knit side.
-  Pattern Stitch – worn on the Purl side.









-  Repeat

- I = Front
- II = Back
- III = Sleeve
- IV = Skirt Front
- V = Skirt Back
- VI = Collar
- VII = Pocket
- VIII = Band
- IX = Belt
- X = Cuff
- XI = Pants Front
- XII = Pants Back

Finishing – Chart Symbols

-  Match numbers on section for assembling.
-  Ease
-  Fold Line
-  Turn to the wrong side and hem.

Stitch Symbols

-  Needles in holding position
-  Needles back into working position.
-  Empty needle (leave in working position)
-  Needle not used (in the out of work position).
-  Two stitches on 1 needle, either transferred from the right side or the left side, then put into holding position.
-  Needle holding 2 stitches. Stitch has been transferred from the RIGHT.
-  Needle holding 2 stitches. Stitch has been transferred from the LEFT.
-  Center of garment section



General Instructions

HOW TO READ THE CHARTS AND INSTRUCTIONS

There are 3 sizes given for each Pattern in KNITTING MAGAZINE. Above each Chart for the different sizes, you will see that the first and smaller sizes might be shown as 8/10, the second size as [12/14] and the third as [16/18]. Check the measurements at the bustline and hips on the Charts to be certain that you will knit the correct size, remembering these are ACTUAL measurements of the completed section and that there must be a bigger allowance at the bustline and hipline for a Jacket or a Coat than there would be for a fitted dress or a fitted blouse or pullover. The question in your mind should be "How do I want this garment to fit...?"

When you have chosen the size you need, you can follow the Charts as shown. You will notice that where the shapings are the same FOR ALL SIZES, only 1 set of shapings will be shown on the first Chart and if you are knitting the 2nd or 3rd size, you simply follow the shapings as given for the first size. If the shapings are different, this will be shown on the Charts and you should follow them as given.

On the Charts, increases and decreases will be shown as follows

5x1

6 The number in the box means number of ROWS between the shapings, while the 5x1 above the box means - 1 st. 5x... so you will increase or decrease 1 st. every 6th row 5x.

ARMHOLE SHAPINGS - NECK SHAPINGS - SHOULDER SHAPINGS - are made on every 2nd row UNLESS there is a number in a box along side or below the shapings. The rule is... where there is no box with a number, the shaping is made on every 2nd row.

THE PRINTED INSTRUCTIONS

You can follow the printed instructions or use them in combination with the Charts. Where there is any question in the printed instructions, you have the Charts to show you how the section will look.

The 3 sizes, with the different amounts of cast on stitches and the different shapings will look like this...

Cast on 124 (136) [148] sts. You will
Cast on 124 sts. for the first size.
Cast on 136 sts. for the 2nd size.
Cast on 148 sts. for the 3rd size.

The important thing to remember is that you MUST READ AHEAD so that you KNOW what to do for the size you are knitting. Sometimes where the number of stitches are the same but the number of times different, you will find shapings like this...
3 sts. 1x (2x) [3x], 2 sts. 1x (2x) [3x], 1 st. 3x (4x) [5x].
As you see, you MUST read ahead in order to follow the instructions as given for YOUR SIZE. The rows will be different for the different sizes in some cases... Shoulder and Neck shapings usually are worked at the SAME TIME for the back section - so watch for the words AT THE SAME TIME.

HOLDING STITCHES ON THE LEFT SIDE WHILE SHAPING THE RIGHT SIDE

When knitting a section of garment in stockinette stitch, it is easy to hold the stitches on the left side while knitting the right half, but when knitting a Pattern Stitch such as a Norwegian Design, a Holding Position Design, Weaving, etc., you should use the following method. For the NECK SHAPING, we tell you to bind off the center sts., put the needles on the left into holding position and complete the right half first... so with a strand of contrast yarn, knit ALL of the left side stitches manually by hand, pulling each stitch back against the needle bed to the OUT OF WORK position. When the right side is completed, carefully pull the stitches held on contrast, forward into working position and as you do so, undo the contrast yarn, line up the needles (KNITTING AM 3 machine owners, put the stitches under the sinkers) and complete the left half.

If you own a Japanese machine, you may find that when knitting the right half with the left side held in this way, the sinker plate will mark the left side while you are knitting the right half. To prevent this marking, you can tape a piece of paper over the knitting, underneath the sinkers, or if you own a Reversing Bar, you can hang this onto the Sinkers while you are knitting the right half. When hanging the Reversing Bar, be sure the eyes of the bar go BETWEEN the Sinker Posts on the upper part of the bar so that the tips of the bar only - show above the needle bed.

FULL FASHION DECREASING OR INCREASING

For Stockinette stitch, always use the Full Fashion method for increasing or decreasing.

TO DECREASE: Hang the 3rd stitch onto the 2nd stitch then move the stitches in to fill the empty needle.

TO INCREASE: Move the 2 end stitches 1 needle outward, then pick up the 3rd stitch from the row below and hang it onto the empty needle.

FINISHING: Block all sections. For PULLOVERS, JACKETS, and DRESSES: Join front to back at sides and shoulders. Sew sleeves together and set in. Hem lower edge and sleeve edges if needed. For a double neckband or armhole band, sew 1 edge to the inside and 1 to the outside of neck or armhole. For a single ribbed band, sew 1 edge to the outside of neck or armhole edge. For a cardigan or jacket with buttonholes, finish buttonholes and sew on buttons.

PANTS: Join front to back at sides. Sew inside leg seams, then join center front and back. Make hem at waistline and insert elastic. Hem lower edge of pants legs.

THE SAMPLE SWATCH

Before you begin to knit any garment, you will need to knit a sample piece using the yarn you have chosen for your garment, so that you can check the stitch and row gauge which must measure the correct number of stitches and rows in 5 cm (2 inches).

For each Pattern in KNITTING MAGAZINE, we give you 3 tension numbers to work from and if you use the specified yarn for the garment, you should be able to get the correct stitch and row gauge using one of these numbers. Here is a very easy way to make your sample swatch and count the stitches and rows without actually counting, by using our KNITTING Converta Tape.

Supposing the Tension Numbers for the Stitch and Row Gauge are given as 5 to 7. Set the Tension Dial to the first number which is 5. With contrast waste yarn, and using the quick cast on method, cast on 60 stitches and knit 10 rows. Change to garment yarn and turn the Row Counter to 0. Knit 30 rows. Counting from each end, knit the 10th stitch on each side by hand with a small piece of contrast yarn. Leave the needles in working position and knit 30 rows (Row 60), then knit 4 rows with contrast waste yarn. Turn the Row Counter to 0 and the Tension Dial to 6 and with garment yarn, knit 30 rows. Mark the 10th stitch on each side as you did before, knit 30 rows, then 4 rows with contrast waste yarn. Turn the Row Counter to 0 and with Tension 7, repeat the above once more, ending with 10 rows of contrast waste yarn. Remove the work from the machine by passing the Slide across the needles without yarn (sometimes called 'dropping'). Pull and stretch the sample piece both lengthwise and diagonally from corner to corner, then lengthwise again. Do not count the stitches and rows immediately, but allow the sample to rest for several hours or even overnight. This will allow the stitches and rows to return to their basic form.

When your sample has rested and you are ready to count the stitches and rows, the KNITTING CONVERTA TAPE will do the counting for you without any counting on your part. Use the Tape as follows:

Measure the stitches with the TAPE, BETWEEN the 40 stitches marked with contrast waste yarn. Push the SLIDE so that the LEFT EDGE lines up to this exact measurement. Now look down along side the SLIDE and find the number 40 on the TAPE. The number directly opposite on the SLIDE will be your Stitch Gauge to 5 cm (2"). To find the number of rows in 5 cm (2"), place the TAPE to measure over the 60 rows, push the SLIDE to this number with the left edge lined up, the look for the number 60 on the TAPE and directly opposite this will be the number of rows to 5 cm (2")

If you do not own a KNITTING CONVERTA TAPE, you must mark a 5 cm (2 inch) square in the center of the knitting, then count the number of stitches and rows within the square.

KK 910

CHILD'S PULLOVER

SIZE 2 to 4
 YARN: Amore
 GRAMS: color 1 100
 colors 2, 3, 4, 5, 6 -50 gr. each color.
 TENSION: 4 to 6
 GAUGE: 16 sts. 30 rows = 5 cm (2")

A Norwegian Design and color stripes as shown on the Charts.
 Bands are striped with K1, P1 Ribbing.

FINISHING: See General Instructions.

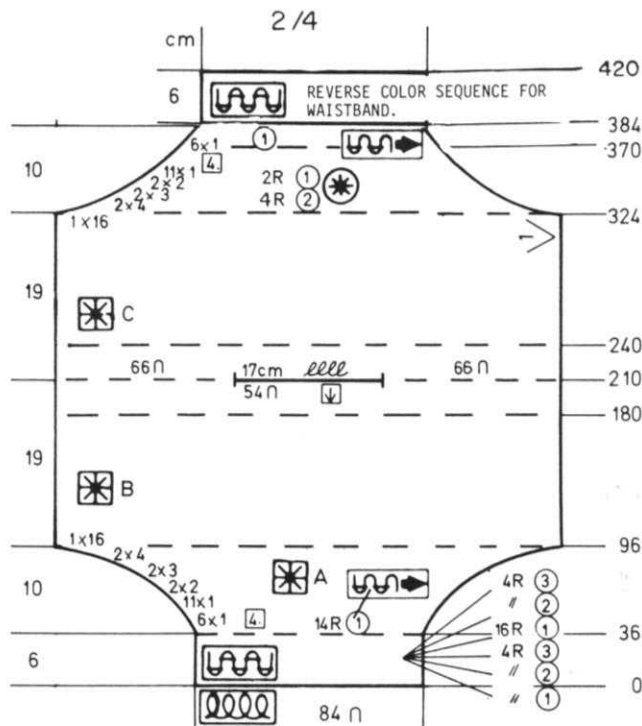
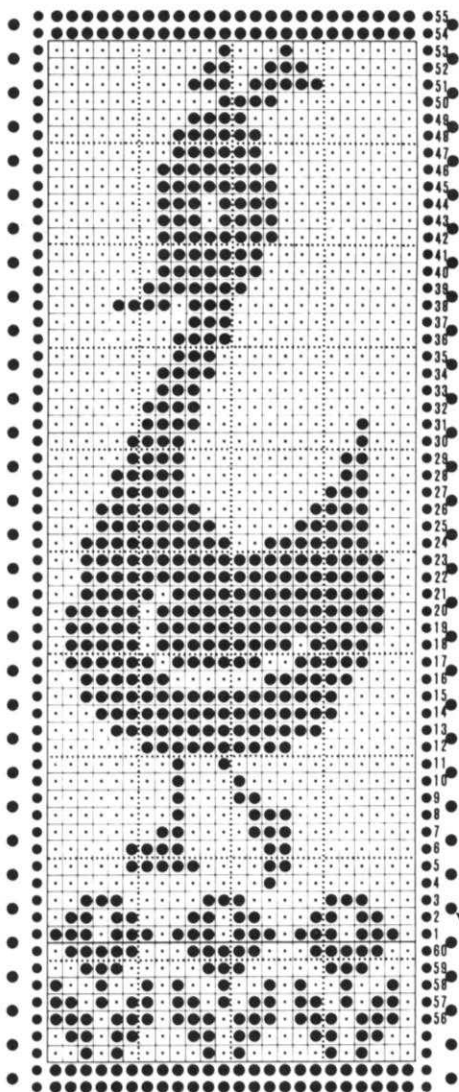

ROWS 180 to 210

4 rows color 2
 2 rows color 3
 4 rows color 4
 2 rows color 3
 4 rows color 5
 2 rows color 3
 4 rows color 4
 2 rows color 3
 6 rows color 2

Reverse color sequence at neckline for stripes.

PATTERN A = FLOWERS
 PATTERN B = DUCK
 PATTERN C = DOTS

Knitted in one piece. Begin at lower edge. Cast on 84 sts. with color 1 and work 16 rows Ribbing with color stripes as shown on the Chart.
 Transfer the Ribber sts. and work 14 rows color 1 in Stockinette st., then continue in PATTERN A (Flowers) AND AT THE SAME TIME, ON EACH SIDE, ON EVERY 4th ROW, increase 1 st. 6x then on every 2nd row, increase 1 st. 11x, 2 sts. 2x, 3 sts. 2x, 4 sts. 2x, 16 sts. 1x and after Row 96, continue in PATTERN B (Duck). After Row 180, continue in Stockinette stitch with color stripes as shown on the Chart.
 After Row 210, bind off the center 54 sts. then IMMEDIATELY CAST on over these same needles. Continue in the Color stripes to Row 240 then work PATTERN C (Dots). After Row 324, work the color stripes as shown on the Chart AND AT THE SAME TIME, ON EACH SIDE, bind off 16 sts. 1x, 4 sts. 2x, 3 sts. 2x, 2 sts. 2x, 1 st. 11x, then ON EVERY 4th row decrease 1 st. 6x. After Row 370, work Stockinette stitch with color 1 to row 384. Transfer the sts. to Ribber and work 16 rows Ribbing with color stripes in REVERSE. After Row 420, bind off.

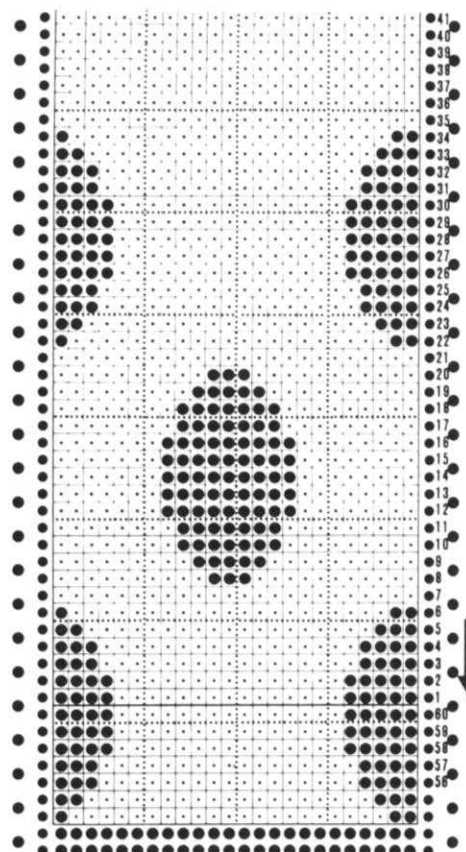

CUFFS:

Cast on 32 sts. (or you can hang the sleeve onto machine, decreasing to 32 sts. Work 12 rows each of 5 different colors in K1, P1 Ribbing. (See Picture). Bind off.

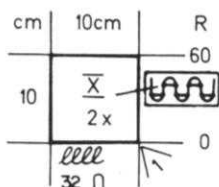

DK 911

WOMAN'S COAT

SIZES: 8/10

YARN: Knitting worsted weight + Novelty yarn + thin yarn for attaching Yoke to lower section.

GRAMS: color 1 1100 (Knitting worsted weight)
color 2 100 (Novelty yarn)

color 3 50 (thin strong yarn)

TENSION: 6 to 8

GAUGE: 8 sts. 10 rows = 5 cm (2")

MADE ON THE JUMBO MACHINE.

Stockinette stitch with eyelets (for pulling color 2 through holes).

FINISHING: Put the Skirt sections together. Hang the back from the center to end - then front onto machine.

With color 2, knit 1 row, then work eyelet row, knit 1 row then hang the yoke to these stitches and bind off. REPEAT for other side.

Pull the heavy novelty yarn through the eyelets (see picture). Work 2 rows single crochet around neck and front edges.

FRONT & BACK:

Make 4 sections the same - two for back and 2 sections for fronts.

Cast on 95 sts. with color 1 and knit 2 rows. *Color 2, knit 1 row. Transfer every 2nd st. to next needle and leave empty needles in working position (eyelet row). Knit 1 row. With color 1, knit 12 rows, then REPEAT from * 3x more. (4x in all). After Row 46, ON EACH SIDE, decrease 1 st. every 30th row 5x. After Row 170, remove onto waste yarn.

YOKE & SLEEVES:

Begin at sleeve edge. Cast on 48 sts. and work in Pattern same as the Front and Back BUT WORK ONLY 10 ROWS BETWEEN THE EYELETS. Continue in Stockinette stitch with color 1. After Row 100, ON EACH SIDE, cast on 19 sts. After Row 118, work the EYELET PATTERN same as fronts and back with ONLY 10 ROWS BETWEEN THE EYELETS.

After Row 147, ON THE LEFT, bind off (or remove onto waste yarn) 46 sts.

Continue in Pattern to Row 167 then cast on 46 sts.

Knit in Pattern to Row 188.

Continue in Stockinette stitch to Row 206.

ON EACH SIDE, bind off 19 sts. Knit to Row 278.

Work the Pattern same as for other sleeve.

After Row 306, bind off.

8/10

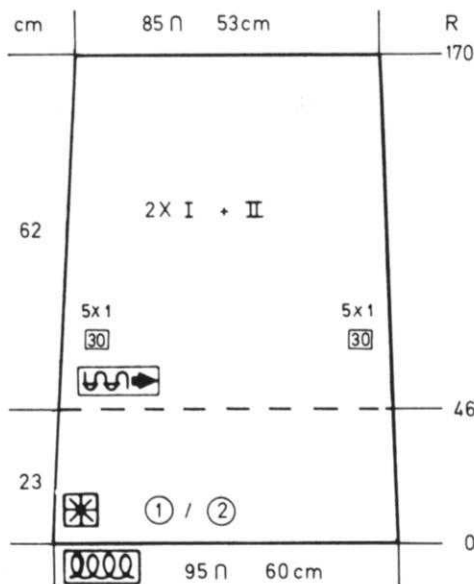

8/10

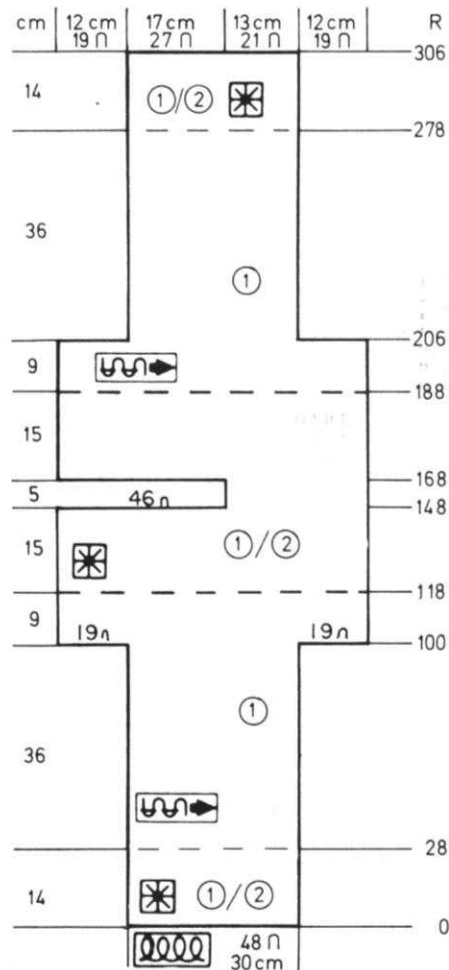

DK 912

WOMAN'S PULLOVER

SIZES: 8/10 (12/14)

YARN: Alpacryl

GRAMS: color 1 150 150
color 2 50 50
color 3 200 200

TENSION: 8 or 9

GAUGE: 11 1/2 sts. 28 rows = 5 cm (2") in Pattern.

A slip stitch pattern for the body and sleeves of Pullover. Punch your own Card and push in BOTH PART BUTTONS. The purl side of pattern is the right side and garment MUST BE REVERSED before knitting the Picot Trims (see picture and watch instructions). Bands for waist and sleeves are K2, P2, Ribbing.

FINISHING: See General Instructions.

WAISTBAND: Make 2.

Cast on 106 (114) sts. with color 3 and work 30 (36) rows Ribbing. Transfer the ribber sts. to main machine, then hang the waist onto these same needles and bind off. REPEAT for other half.

NECKBAND: Make 2.

Cast on 46 sts. with color 3 and work Stockinette stitch. Knit 15 rows, 1 row with tension 10 then knit 15 rows. Hang hem and bind off.

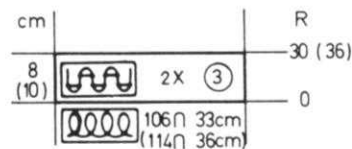
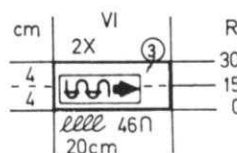

DK 912

BEGIN AT SLEEVE EDGE.

Cast on 50 (55) sts. with color 1 and work 30 rows Ribbing.

Transfer the Ribber sts. to main machine and with color 1 continue in the slip stitch pattern.

ON EACH SIDE, increase 1 st.

every 30th row 6x.

After Row 230 ON EACH SIDE, ON EVERY 4th ROW, cast on

1 st. 2x, 2 sts. 2x, 3 sts. 1x.

After Row 252, ON EACH SIDE, cast on ALL STS. (200 needles in work).

Knit to Row 258.

REVERSE KNITTING.

Knit 1 row Tension 10.

After Row 266, transfer every 2nd st. to neighboring needle and leave empty needles in working position.

Knit to Row 276 then hang the hem (pick up the tension 10 row).

Change to color 2. Knit to Row 286.

Knit 1 row Tension 10.

After Row 294, Make picot row same as before and after Row 304, hang the hem as before.

Change to color 3 and knit to Row 314. Knit 1 row Tension 10 then

knit to Row 322. Make Picot Row as before and after Row 332, hang the hem as before. REVERSE KNITTING.

Work in Pattern to Row 354 (360)

Bind off the center 18 sts., put the needles on the left into holding position and work the right side first.

Continue in Pattern to Row 466 (472)

Put these needles into holding position and bring the needles on the left into working position to work the left side.

Counter at 354 (360).

Knit in Pattern to Row 466 (472).

Cast on the center 18 sts., bring all the needles into working position and put Counter at 466 (472).

Knit in Pattern to Row 488 (500) then remove the sts. onto contrast waste yarn.

Work the 2nd section with reverse shaping up to Row 332. Leave the sts. on the needles and hang the first section onto these same needles then bind off.

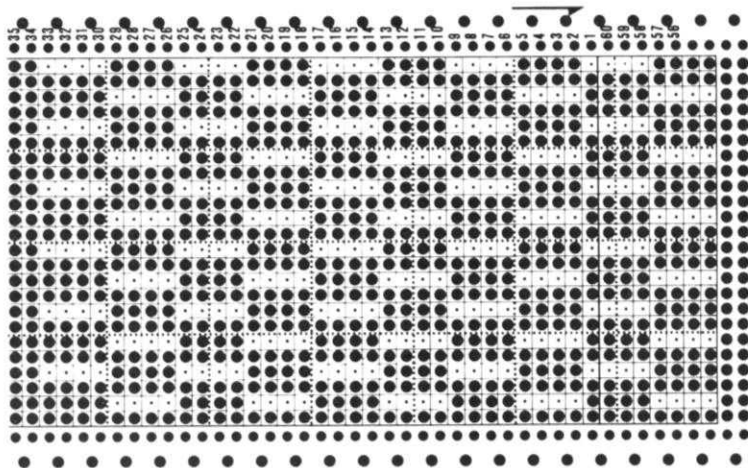
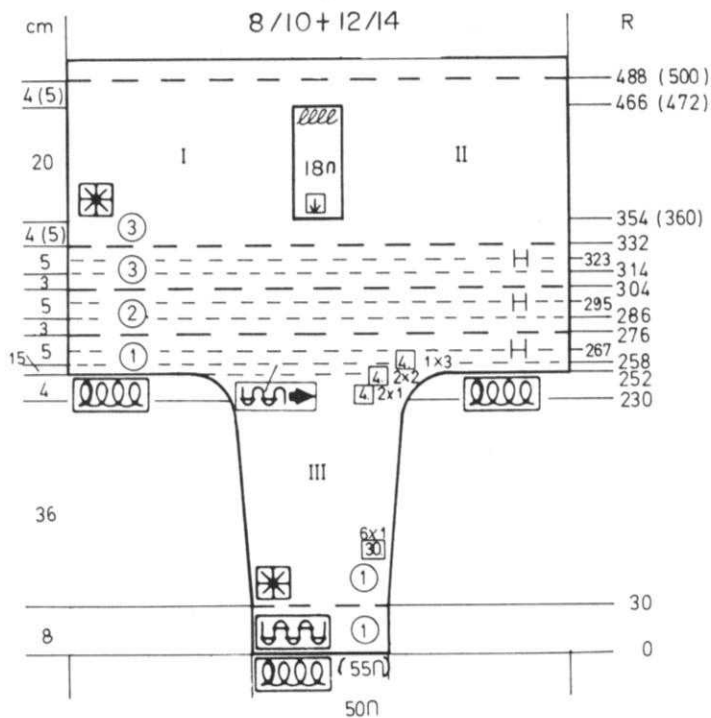

KK 913

CHILD'S 2-PIECE SUIT

SIZES: 4 (6) [8]
 YARN: Mohair
 color 1 400 400 450
 color 2 50 50 50
 color 3 50 50 50
 TENSION: 6 or 7
 GAUGE: 14 sts. 21 rows = 5 cm (2")

Use the Ribber with 830 Color Changer for the design on top of Jacket. Punch your own Card.

FINISHING: See General Instructions.

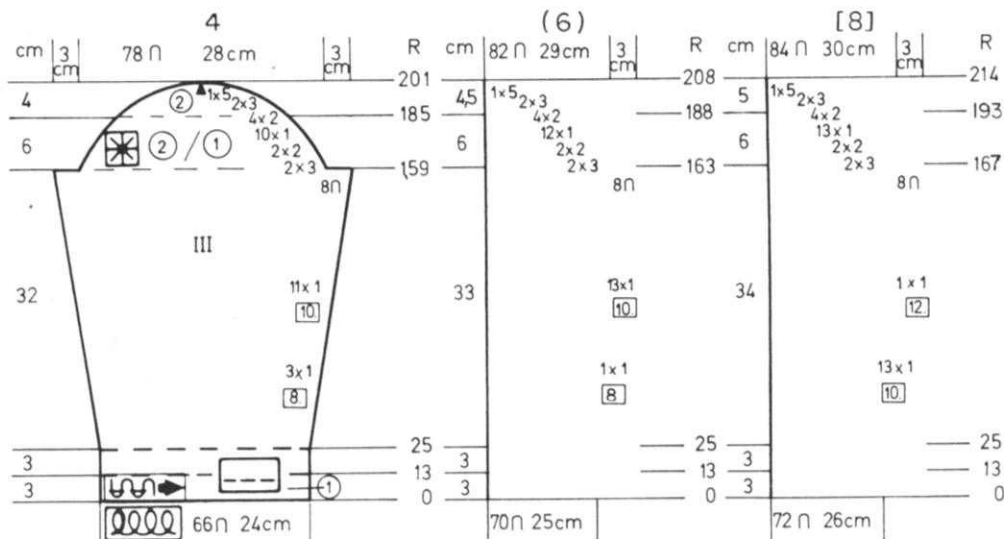

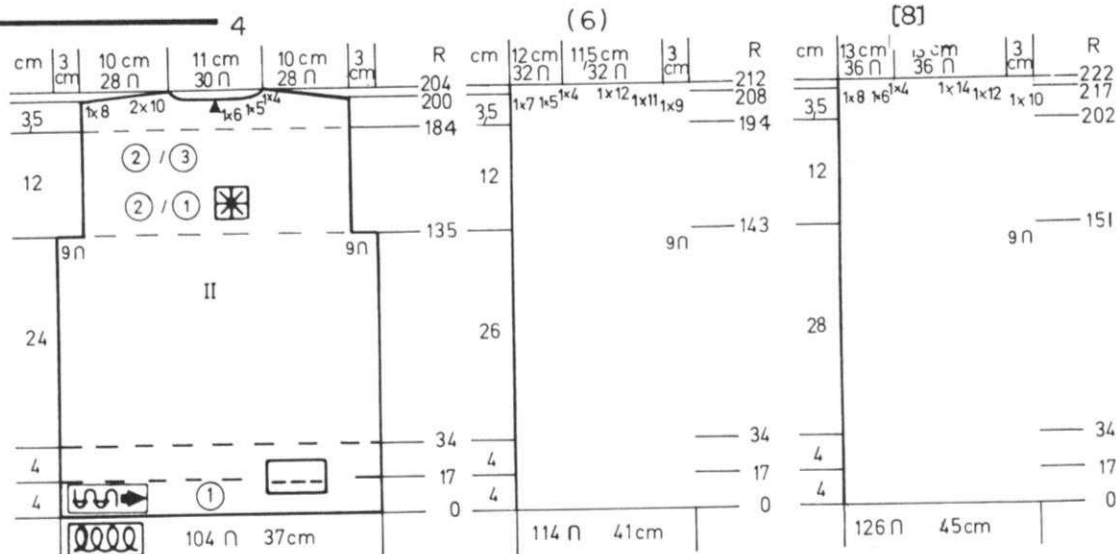

JACKET BACK: II

Cast on 104 (114) [126] sts. with color 1 and work with 1 strand of yarn to Row 17. Knit 1 row Tension 9 or 10 then continue with double yarn.

After Row 34, hang the hem. Knit to Row 135 (143) [151]. ON EACH SIDE, bind off 9 sts. Set the Pattern on the next row from left to right and continue in Pattern as shown on the Chart, using 1 strand color 1 & 2 then 2 & 3 till Pattern is completed at Row 184 (194) [202]. Continue with 1 strand color 2 to Row 200 (208) [218].

SHAPE SHOULDER AND NECK AT THE SAME TIME.

Bind off the center 12 (14) [16] sts., put the needles on the left into holding position and complete the right side first.

*FOR SHOULDER, bind off 8 sts. 1x, 10 sts. 2x (9 sts. 1x, 11 sts. 1x, 12 sts. 1x) [10 sts. 1x, 12 sts. 1x, 14 sts. 1x] FOR NECK, bind off for all sizes 5 (5) [6] sts. 1x, 4 sts. 1x. Bring the needles on the left into working position, knit 1 row to the left side, turn the Row Counter back to 200 (208) [218] and complete the left half. Follow the instructions from *.

SLEEVES: III

Cast on 66 (70) [72] sts. with single strand of color 1 and work Stockinette stitch.

After Row 13, continue with double yarn.

After Row 25, hang the hem. ON EACH SIDE, increase

1 st. every 8th row 3x, every 10th row 11x. (every 8th row 1x, every 10th row 13x).

[every 10th row 13x, every 12th row 1x].

After Row 159 (163) [167] Begin Pattern with color 2 and 1 and ON EACH SIDE, bind off 8 sts.

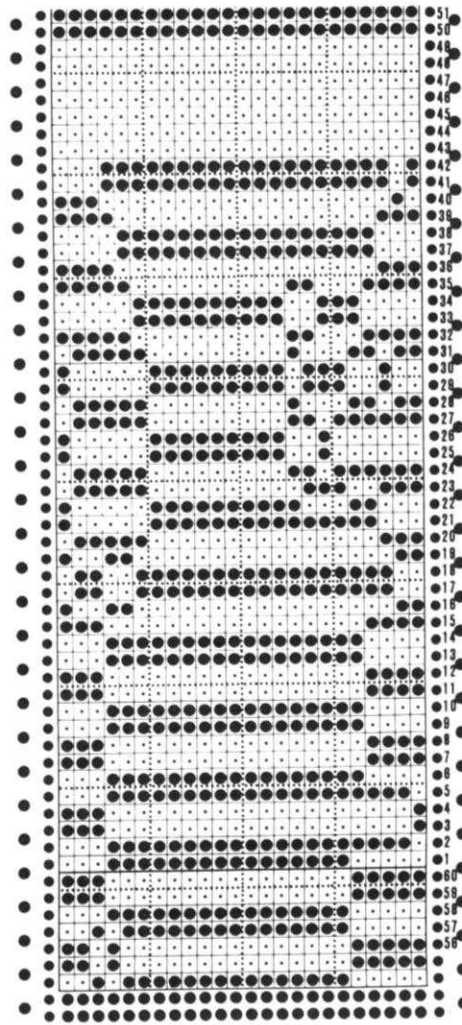
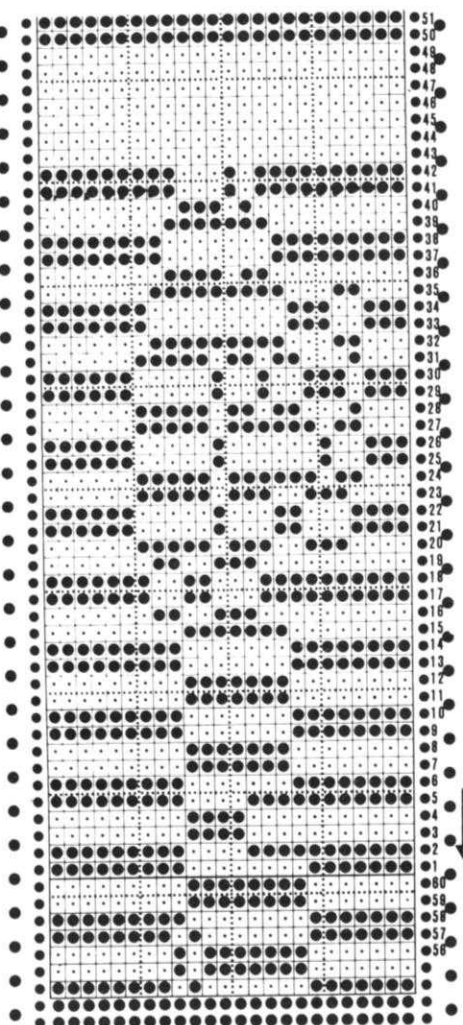

SHAPE CAP: ON EACH SIDE, bind off 3 sts. 2x, 2 sts. 2x, 1 st. 10x, 2 sts. 4x, 3 sts. 2x 5 sts. 1x. (3 sts. 2x, 2 sts. 2x, 1 st. 12x, 2 sts. 4x, 3 sts. 2x, 5 sts. 1x). [3 sts. 2x, 2 sts. 2x, 1 st. 13x, 2 sts. 4x, 3 sts. 2x, 1 st. 5x] BUT AT THE SAME TIME, change to Stockinette stitch with color 2 after Row 185 (188) [193].

When working the Pattern, leave the KC on at all times. The plain rows are knitted with the main color and you must RELEASE the PART BUTTONS. When the needles set into pattern, push both PART BUTTONS IN. Remember that the second set of elephants are knitted in another color.



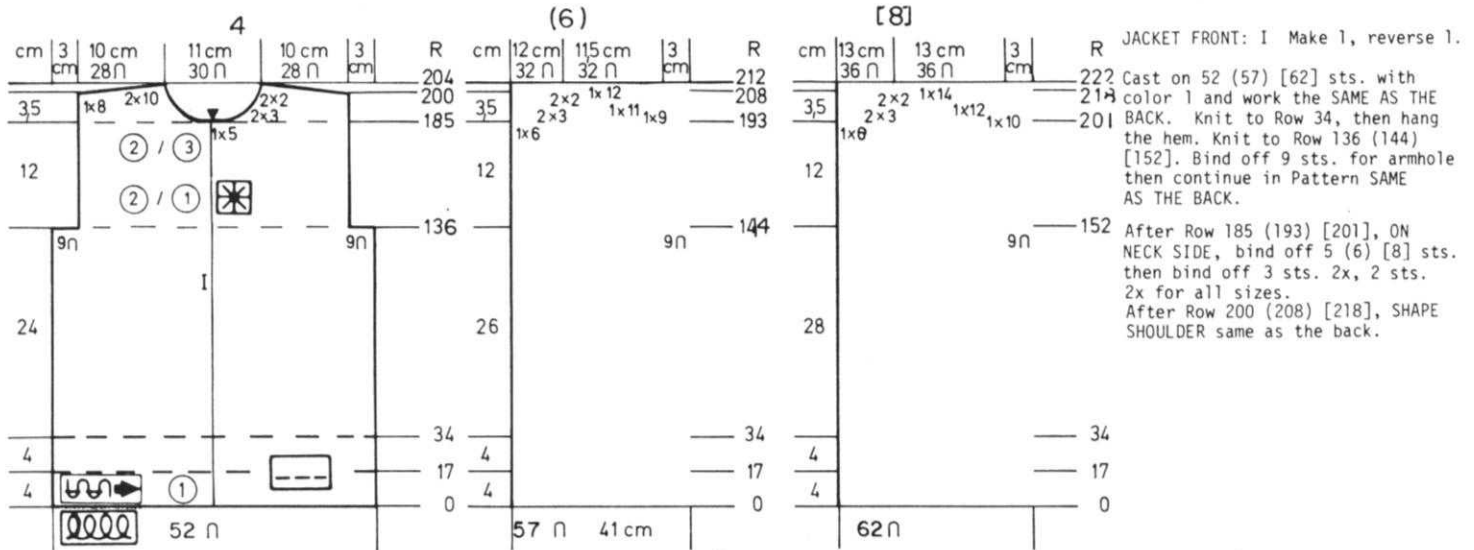

FRONT BANDS:

Hang right front edge of Jacket onto machine on 106 (112) [118] needles. With 1 strand color 1, knit 16 rows Stockinette stitch BUT AT THE SAME TIME, at left edge increase 1 st. every 4th row 3x. After Row 17, use 2 strands of yarn and tension 10 and increase 1 st. every 4th row 3x. Remove onto waste yarn. Work the left front band with reverse shapings.
 (IF YOU WANT BUTTONHOLES ON THE RIGHT FRONT BAND, work them in and space them as desired).

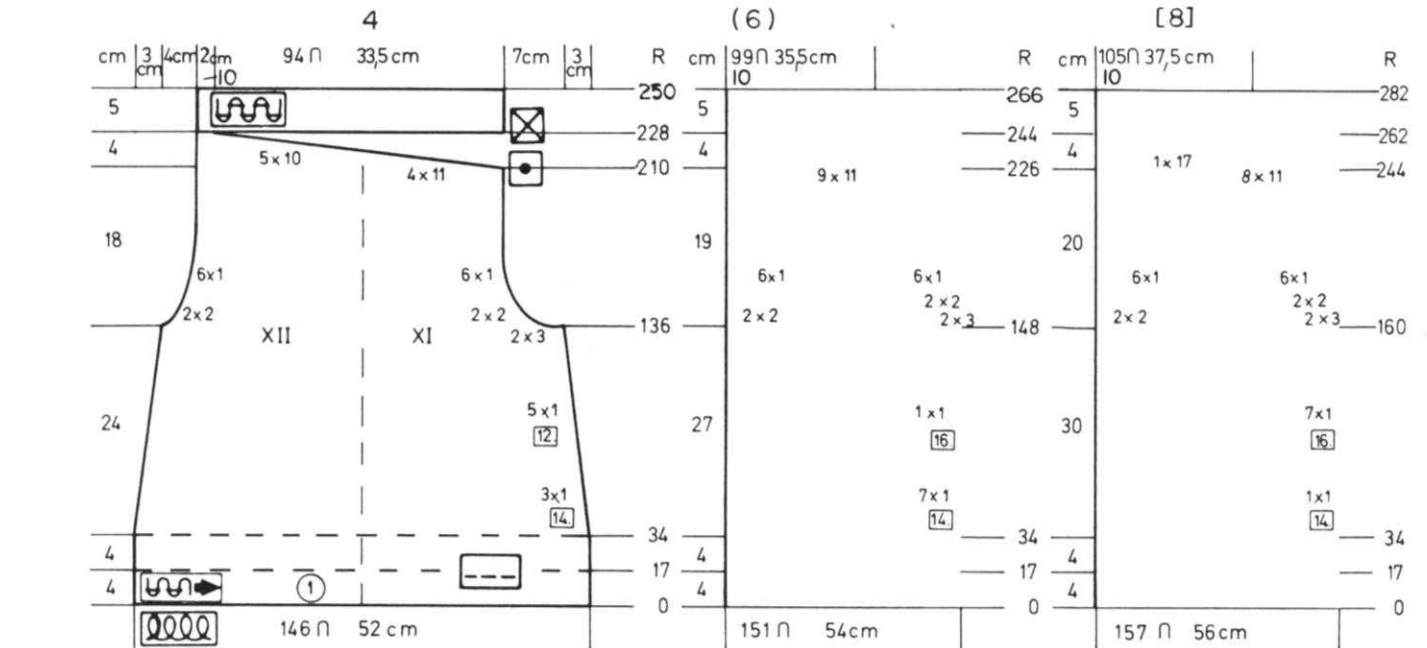
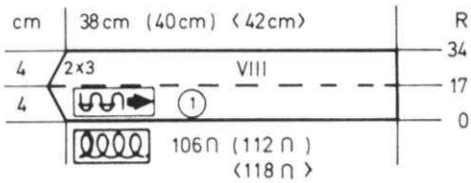

DK 914

WOMAN'S 3-PIECE SUIT

SIZES: 8/10 (12/14)
 YARN: Pingouin Pescadou
 GRAMS: color 1 700 750
 color 2 400 450
 color 3 250 300
 TENSION: 8 to 9 - Jacket
 7 to 8 - Pullover & Skirt
 GAUGE: 13 sts. 25 rows = Pull. & Skirt
 15 sts. 20 rows = Jacket = 5cm

The Jacket is knitted in Norwegian technique. 840 Machine owners use Card No. 1 - or punch your own Card. The purl side is the right side. The Pullover is striped in color 1 & 2. The skirt is Stockinette stitch using color 1.

FINISHING: See General Instructions. Work Double Crochet using 2 strands of yarn around all edges of Jacket.

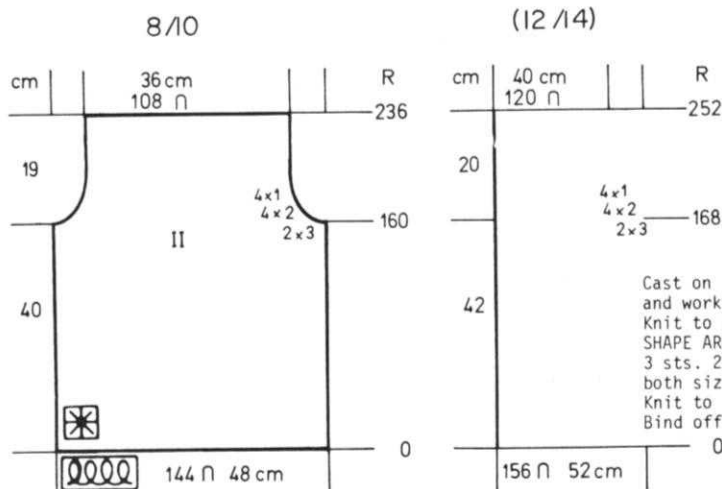

JACKET BACK: II

Cast on 144 (156) sts. with color 2 and work in Pattern. (color 2 & 3) Knit to Row 160 (168).
 SHAPE ARMHOLE: ON EACH SIDE, bind off 3 sts. 2x, 2 sts. 4x, 1 st. 4x. for both sizes.
 Knit to Row 236 (252).
 Bind off.

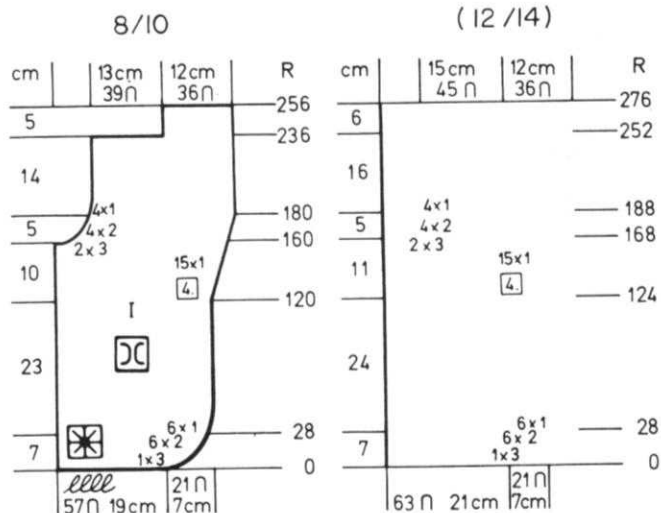
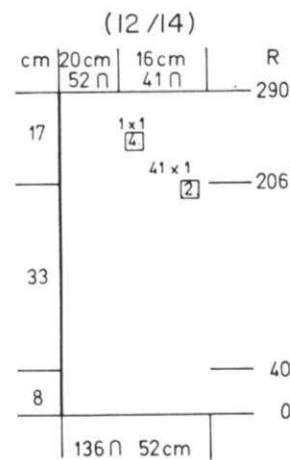
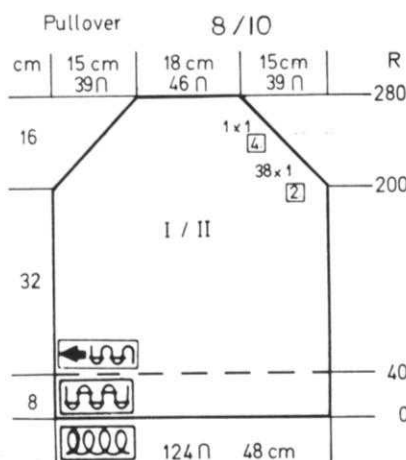

PULLOVER BACK & FRONT I/II

Both Front and Back are the same. Worn on the Purl Side. Work in color stripes of 2 rows color 1, 2 rows color 2 after the Ribbing.
 Cast on 124 (136) sts. with color 1 and work 40 rows Ribbing. Continue in Stripe Pattern. Knit to Row 200 (206).
 SHAPE RAGLAN:
 ON EACH SIDE, BIND OFF
 1 st. every 2nd row 38x, 1 st. every 4th row 1x.
 (1 st. every 2nd row 41x, 1 st. every 4th row 1x).
 After Row 280 (290), bind off the remaining sts.

JACKET FRONT: I Make 1, reverse 1.

Cast on 57 (63) sts. with color 2 and work in Pattern. (color 2 & 3)
 ON THE RIGHT (left for 2nd section) cast on 3 sts. 1x, 2 sts. 6x, 1 st. 6x for both sizes.
 Knit to Row 120 (124).
 ON THE RIGHT, (left) increase 1 st. every 4th row 15x for both sizes and after Row 161 (167),
 SHAPE ARMHOLE: Bind off 3 sts. 2x, 2 sts. 4x, 1 st. 4x for both sizes.
 After Row 237 (253) Bind off 39 (45) sts.
 Knit to Row 256 (276) then bind off the remaining sts.

JACKET SLEEVES III

Cast on 72 (78) sts. with color 2 and work in Pattern. ON EACH SIDE, increase 1 st. every 8th row 12x, every 10th row 6x. (every 8th row 17x, every 6th row 4x).
 After Row 156 (160), SHAPE CAP:
 ON EACH SIDE, bind off
 4 sts. 1x, 2 sts. 5x, 1 st. 20x, 2 sts. 4x, 4 sts. 1x, 8 sts. 1x. (5 sts. 1x, 3 sts. 1x, 2 sts. 4x, 1 st. 22x, 2 sts. 4x, 5 sts. 1x, 9 sts. 1x).

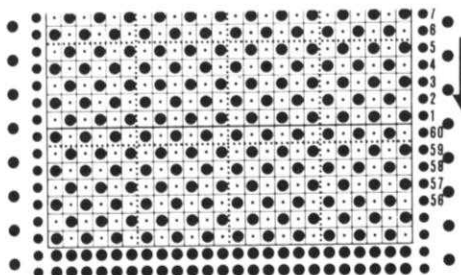
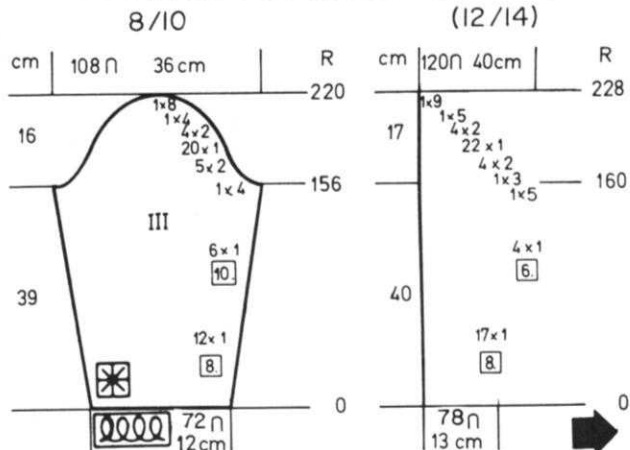

DK 914

PULLOVER SLEEVES: III

Cast on 56 (62) sts. with color 1 and work 40 rows ribbing. Continue in Stripe Pattern. ON EACH SIDE, increase 1 st. every 8th row 15x, every 10th row 5x. (every 6th row 2x, every 8th row 21x). After Row 210 (220), SHAPE RAGLAN: ON EACH SIDE, bind off 1 st. every 2nd row 13x, every 4th row 15x. (1 st. every 2nd row 17x, every 4th row 14x). After Row 296 (310), bind off the remaining sts.

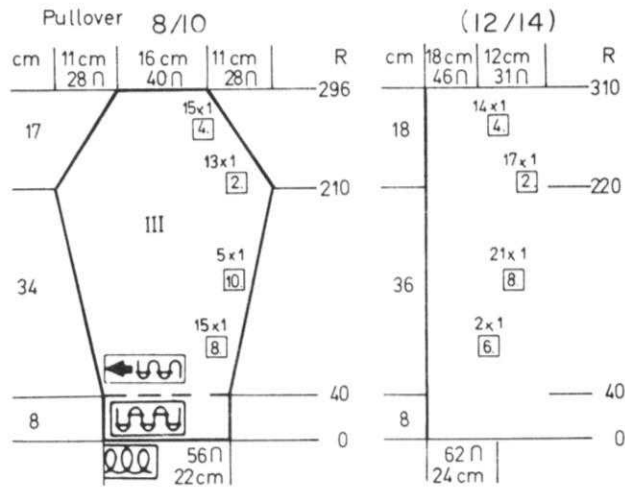

SKIRT: IV/V - Two sections the same.

Cast on 130 (150) sts. with color 1 and work Stockinette stitch. Knit to Row 260. ON EACH SIDE, decrease 1 st. every 8th row 10x, every 2nd row 5x for both sizes. After Row 350, bind off the remaining stitches.

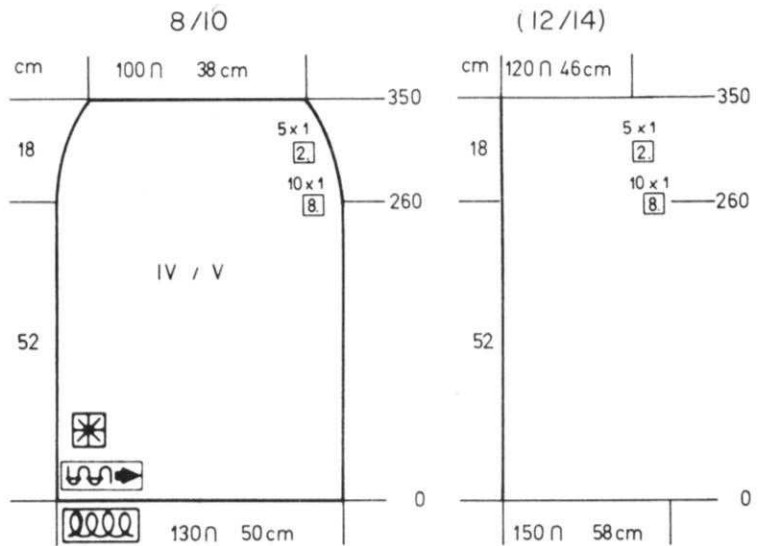

DK 915

WOMAN'S DRESS

SIZES: 7/8 (10/12)
YARN: Pingouin Pescadour
GRAMS:
color 1 400 450
color 2 150 200
color 3 100 150
TENSION: 7 or 8
GAUGE: 13 sts. 25 rows = 5 cm (2")

Stockinette stitch using 3 colors on both front and back. Sleeves and Neck Bands are ribbed.

FINISHING: See General Instructions. Sew sections together on front and back before putting garment together.

SLEEVES: III

Cast on 52 sts. with color 1 and work 50 rows Ribbing. Continue in Stockinette stitch with color 1. ON EACH SIDE, increase 1 st. every 6th row 4x, every 8th row 17x. (every 6th row 3x, every 8th row 19x). After Row 210 (220), SHAPE CAP: ON EACH SIDE, bind off 3 (4) sts. 1x, 2 sts. 2x, 1 st. 8x, 1 st. every 4th row 13x, 1 st. every 2nd row 8x, 2 sts. 1x, 3 sts. 1x, 6 sts. 1x.

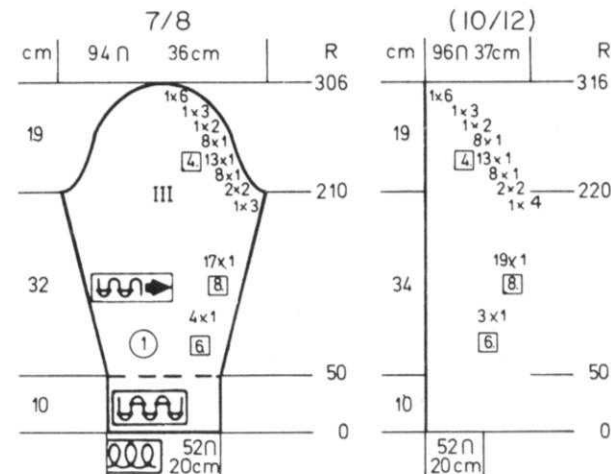
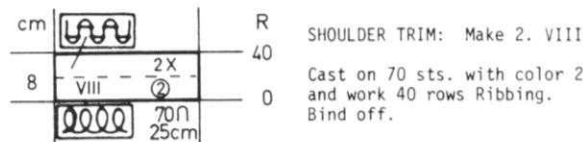

NECKBAND: VI

Cast on 96 sts. with color 2 and work in Ribbing. ON EACH SIDE, on every 2nd row, decrease 1 st. 4x. After Row 20, ON EACH SIDE, increase 1 st. 4x. After Row 40, bind off.

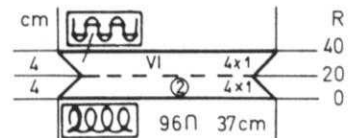

DK 915

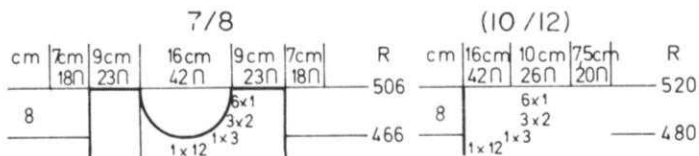

Work the front the same as the back EXCEPT for the CENTER SECTION FOR SHAPING THE NECKLINE.

Knit the center section as given to Row 466 (480) then SHAPE NECK. Bind off the center 12 sts., put the needles on the left into holding position and work the right side first. *ON NECK SIDE, bind off 3 sts. 1x, 2 sts. 3x, 1 st. 6x. After Row 506 (520) bind off the remaining sts. Bring the remaining center sts. into working position, turn the Row Counter to 466 (480) and complete the left side. Follow the instructions from *. Work the remaining section same as back.

BACK: II

Cast on 124 (134) sts. with color 1 and work Stockinette stitch. Knit to Row 190 (200). Put all but 41 (46) sts. on the right

into holding position and work over these 41 (46) sts. only. Knit to Row 410 (420).

SHAPE ARMHOLE: Bind off 3 sts. 2x, 2 sts. 4x, 1 st. 4x. (3 sts. 2x, 2 sts. 4x, 1 st. 6x). After Row 506 (520), bind off.

Bring the remaining sts. into working position and put Counter at 190 (200). With color 2 continue to Row 290 (300). Put 41 (46) sts. on the left into holding position and work over the center 42 sts. to Row 506 (520). Bind off.

Bring the remaining 41 (46) sts. into working position. Row Counter 290 (300).

With color 3 knit to Row 411 (421). Turn Row Counter back to 410 (420) SHAPE ARMHOLE same as you did for right side then knit to Row 506 (520) and bind off.

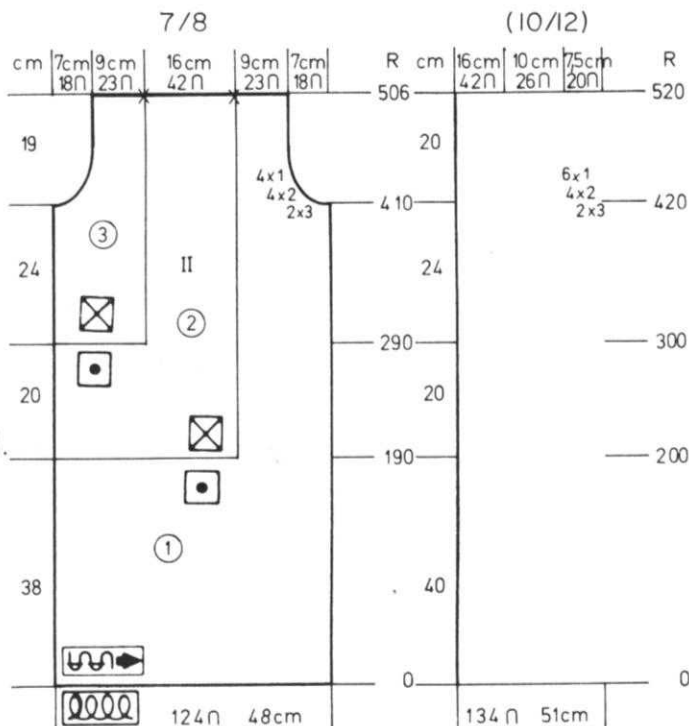

DK 916

WOMAN'S PULLOVER WITH ROUND YOKE

SIZES: 10 (12)
YARN: Pingouin Pescadore

GRAMS: color 1 500 500
color 2 50 50

TENSION: 10
GAUGE: 1 1/2 sts. 18 rows = 5 cm (2")
= Stockinette stitch
15 sts. 18 rows = 5 cm (2")
= Pattern for Yoke.

Stockinette stitch with Norwegian Technique for the Yoke. Punch your own Card. Bands and Collar are K1, P1 Ribbing.

FINISHING: Leave space at front of Yoke when sewing on Collar. See Picture. Single crochet around edges.

COLLAR:

Cast on 88 sts. with color 1 and work 27 rows Ribbing. Bind off.

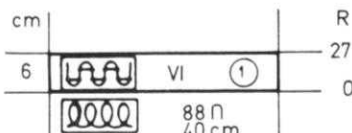

BACK: II

Cast on 106 (110) sts. with color 1 and work 36 rows Ribbing. Continue in Stockinette stitch. Knit to Row 130 (134). SHAPE ARMHOLE: ON EACH SIDE, bind off for both sizes 3 sts. 2x, 2 sts. 2x, 1 st. 4x. Knit to Row 162 (170). Bind off the center 22 (26) sts.

put the needles on the left into holding position and complete the right side first. *ON NECK SIDE, bind off 6 sts. 2x, 4 sts. 4x. Bring the needles on the left into working position, knit 1 row to the left side, turn the Row Counter back to 162 (170) and complete the left half. Follow the instructions from *.

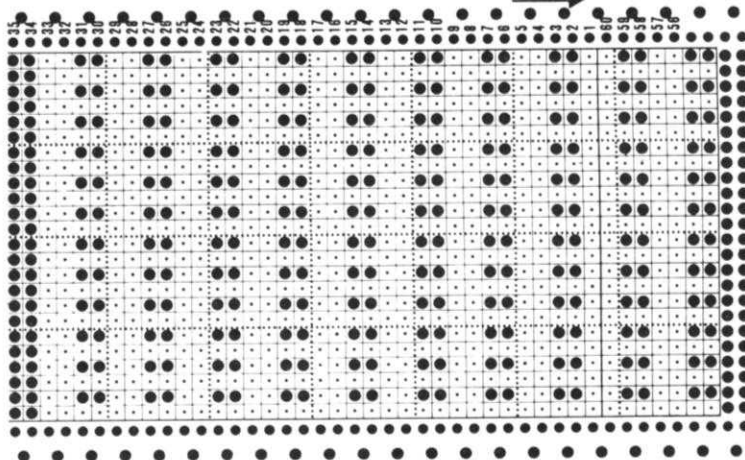
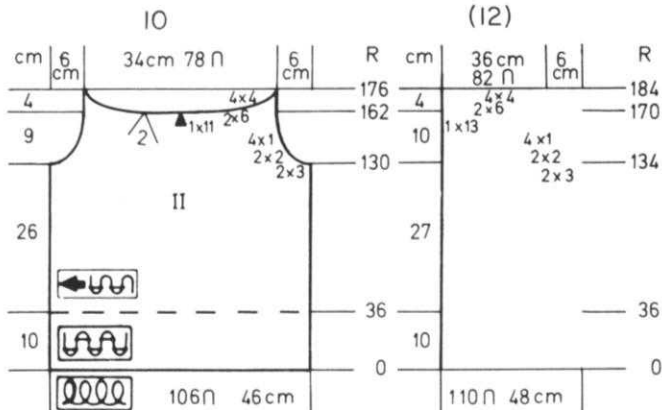

DK 916

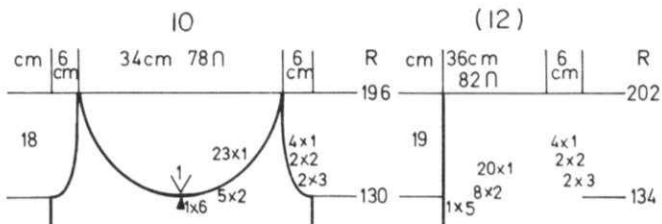
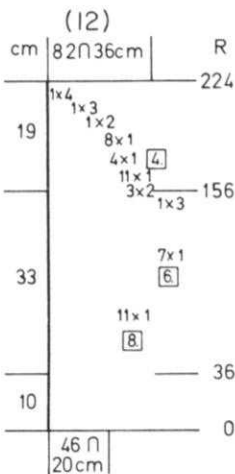
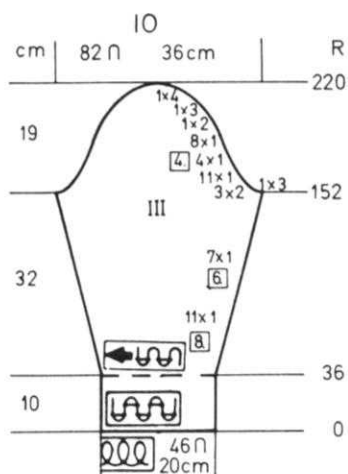

FRONT: I

The front is worked the same as the back to Row 130 (134). Bind off the center 12 (10) sts., put the needles on the left into holding position and complete the right side first.

*SHAPE ARMHOLE same as the back and AT THE SAME TIME, ON NECK

SIDE, bind off 2 sts. 5x, 1 st. 23x.

(2 sts. 8x, 1 st. 20x) Bring the needles on the left into working position, knit 1 row to the left side, turn the Row Counter back to 130 (134) and complete the left half. Follow the instructions from *.

SLEEVES: III

Cast on 46 sts. with color 1 and work 36 rows Ribbing. Continue in Stockinette stitch. ON EACH SIDE, increase 1 st. every 8th row 11x, every 6th row 7x for both sizes. After Row 152 (156), SHAPE CAP: ON EACH SIDE, bind off for both sizes 3 sts. 1x, 2 sts. 3x, 1 st. 11x, 1 st. every 4th row 4x, then 1 st. every 2nd row 8x, 2 sts. 1x, 3 sts. 1x, 4 sts. 1x.

BACK YOKE:

Cast on 34 (36) sts. with color 1 and work in Norwegian Pattern. ON EACH SIDE, ON EVERY 2nd row, cast on 7 (8) sts. 2x, 5 sts. 4x. After Row 32, bind off.

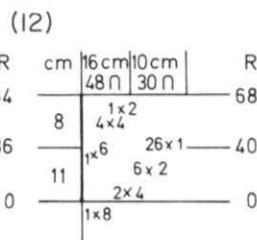
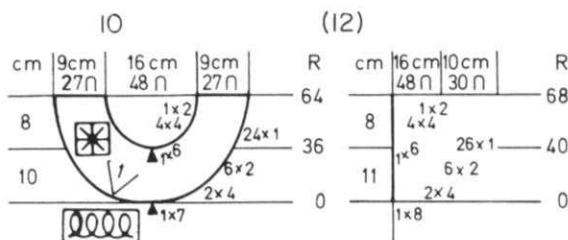

FRONT YOKE:

Cast on 14 (16) sts. with color 1 and work in Norwegian Pattern. ON EACH SIDE, on every 2nd row, cast on 4 sts. 2x, 2 sts. 6x for both sizes. After Row 36 (40), bind off the center 12 sts., put the needles on the left into holding position and complete the right side first.

*ON OUTER EDGE, INCREASE 1 st. every 2nd row 24x (26x) AND AT THE SAME TIME, ON NECK SIDE, bind off 4 sts. 4x, 2 sts. 1x. After Row 64 (68), bind off the remaining sts. Bring the needles on the left into working position, knit 1 row to the left side, turn the Row Counter back to 36 (40) and complete the left half. Follow the instructions from *.

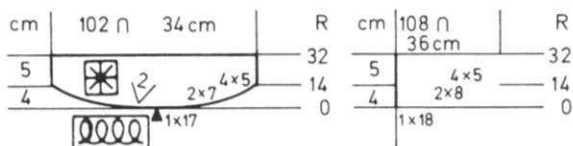

DK 917

WOMAN'S DRESS

SIZES: 5/6 (8/10)
YARN: Vienna & Mami Rex
GRAMS: color 1 400 450
color 2 1 Spool for both sizes
TENSION: 4 or 5
GAUGE: 14 1/2 sts. 25 rows = 5 cm (2")

A Tuck Stitch Pattern. Punch your own Card and push in BOTH TUCK BUTTONS. The Pattern is 8 rows Tuck with color 1 and two rows Stockinette stitch with color 2. Knitted sideways.

FINISHING: See General Instructions. Close back seam, close upper part of back for 16 cm and 9 cm for front.

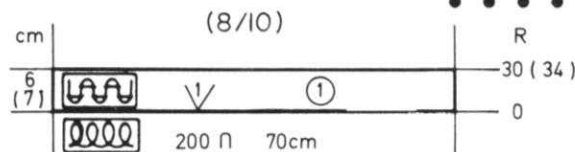

WAISTBAND

Pick up sts. from the skirt (decreasing where necessary) and place on 200 needles. Knit 1 row Stockinette stitch,

transfer to the Ribber and work 30 (34) rows Ribbing. Transfer the ribber sts. to main machine then hang the bodice to these sts. and bind off.



DK 917

BODICE: III Make 2 sections the same.

Begin at Sleeve edge.

Cast on 50 (68) sts. with color 1 and work 15 rows Stockinette stitch then hang the hem.

Continue in Pattern.

ON EACH SIDE, increase 1 st.

every 6th row 1x, every 8th row 1x for both sizes.

After Row 150 (154) ON EACH SIDE,

increase 1 st.

every 2nd row 12x, then cast on 2 sts. 6x, 4 sts. 2x.

After Row 220 (224) ON EACH SIDE, cast on 26 sts.

Continue in Pattern to Row 325 (335). (mark this row for hem)

Continue in Stockinette to Row

340 (350) then hang the marked

row and bind off.

SKIRT: IV/V

Begin and end with waste yarn.

Using Waste Yarn, cast on 200 sts.

After knitting 8 to 10 rows,

change to color 1 and work in Pattern.

Counter at 0. Knit to Row 500 (520).

Remove onto contrast waste yarn.

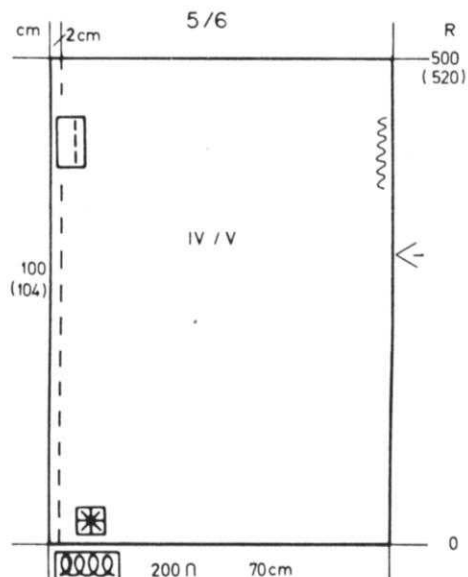
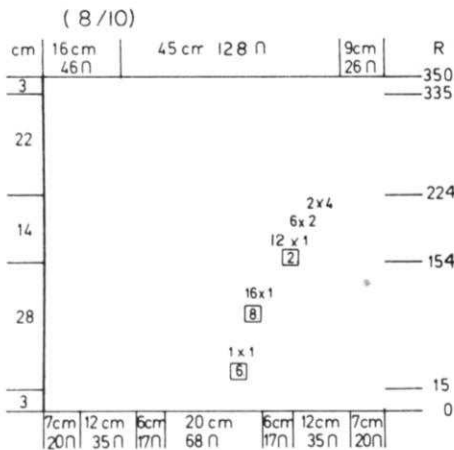
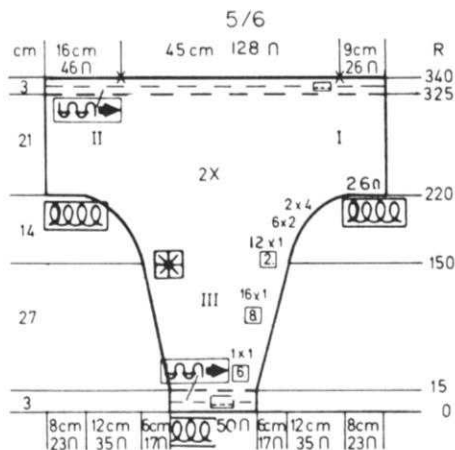

DK 918

WOMAN'S CLASSIC PULLOVER
IN 4 SIZES.

SIZES: 7/8 (10/12) [14/16] /18/20/

YARN: Pingouin Oued

GRAMS: 300 300 350 350

TENSION: 8 to 9

GAUGE: 12 sts. 17 rows = 5 cm (2")

Stockinette stitch with K1, P1 Ribbing
for Bands.

FINISHING: See General Instructions.

BACK: II

Cast on 112 (120) [136] /156/ sts. and
work 20 rows Ribbing.

Continue in Stockinette stitch.

Knit to Row 122 (126) [126] /130/

SHAPE ARMHOLE: ON EACH SIDE bind off

3 sts. 2x, 2 sts. 2x, 1 st. 1x.

(3 sts. 2x, 2 sts. 2x, 1 st. 2x).

[3 sts. 2x, 2 sts. 2x, 1 st. 4x].

/3 sts. 2x, 2 sts. 6x, 1 st. 4x/.

Knit to Row 190 (196) [200] /208/.

Bind off the center 20 (20) [26]

/26/ sts. and put the needles on

the left into holding position.

Complete the right side first.

*SHAPE SHOULDER AND NECK AT THE

SAME TIME.

FOR SHOULDER, bind off

5 sts. 4x, 6 sts. 1x,

(6 sts. 4x, 5 sts. 1x),

[6 sts. 4x, 8 sts. 1x],

/5 sts. 6x, 4 sts. 1x/.

FOR NECK, bind off

5 sts. 1x, 4 sts. 1x for all

sizes.

Bring the needles on the left into
working position, knit 1 row to the
left side, turn the Row Counter
back to 190 (196) [200] [208] and
complete the left half. Follow the
instructions from *.

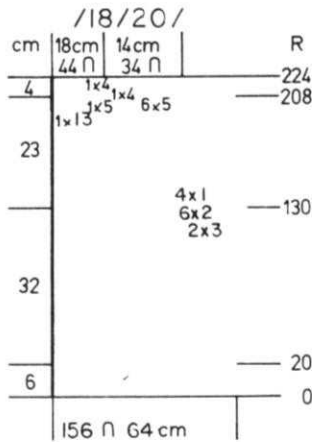
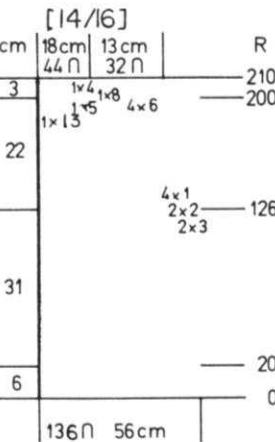
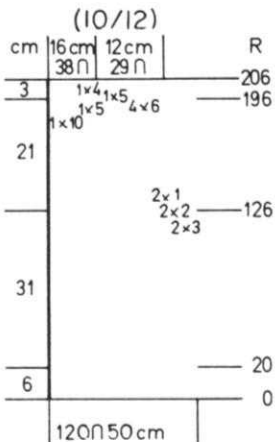
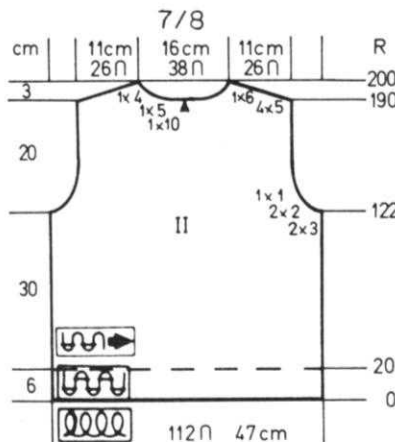

DK 918

SLEEVES: III

Cast on 52 (58) [58] /64/ sts. and work 20 rows Ribbing. Continue in Stockinette stitch. **ON EACH SIDE, increase 1 st. every 12th row 10x.** (every 12th row 6x, every 10th row 5x).
 [every 10th row 7x, every 8th row 7x].
 /every 8th row 14x, every 6th row 2x/.
 After Row 140 (142) [146] /146/
SHAPE CAP:
 PLEASE FOLLOW THE INSTRUCTIONS FOR CAP SHAPING ON EACH SIDE BY FOLLOWING THE CHART for YOUR SIZE.

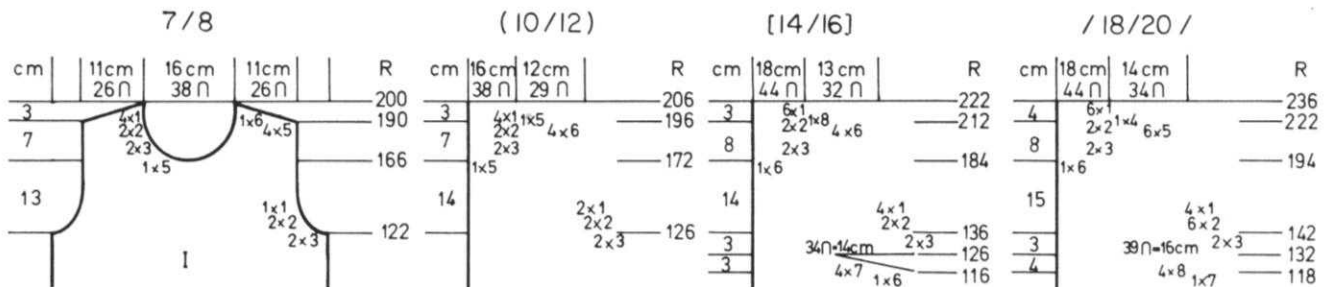
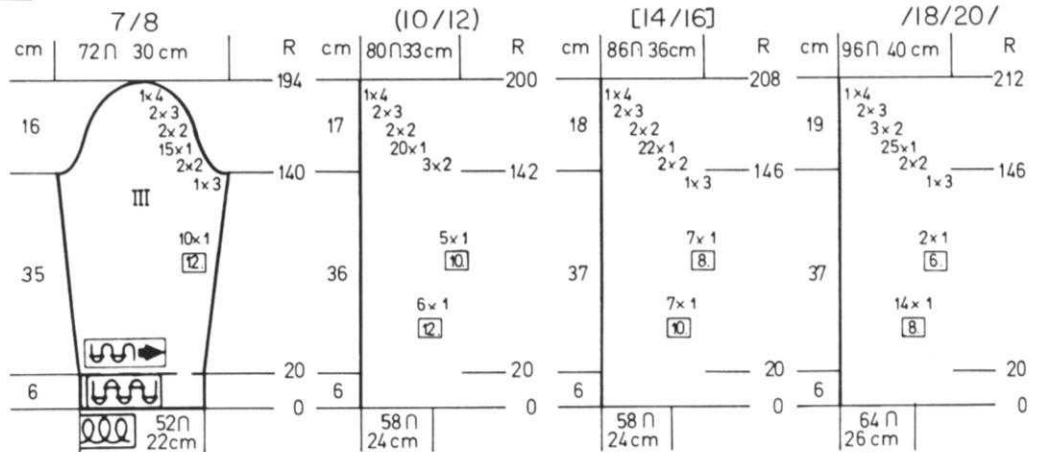

FRONT: I

Work the front the same as the back to Row 122 (126) [116] /118/. FOR THE LAST 2 SIZES ONLY, WORK BUST DARTS ON EACH SIDE. ON OPPOSITE SIDE OF SLIDE, put into holding position [6] /7/ sts. 1x, [7] /8/ sts. 4x ON EACH SIDE. Bring all the needles back into working position before knitting the next 2 rows.
 AFTER ROW 122 (126) [136] /142/
 SHAPE ARMHOLE SAME AS THE BACK.
 After Row 166 (172) [184] /194/
 Bind off the center 10 (10) [12] /12/ sts., put the needles on the left into holding position and complete

the right side first.
 *ON NECK SIDE, bind off 3 sts. 2x, 2 sts. 2x, 1 st. 4x. (Same as first size).
 [3 sts. 2x, 2 sts. 2x, 1 st. 6x]. /Same as 3rd size/.
 After Row 190 (196) [212] /222/, SHAPE SHOULDER same as back. Bring the needles on the left into working position, knit 1 row to the left side, turn the Row Counter back to 166 (172) [184] /194/ and complete the left half. Follow the instructions from *.

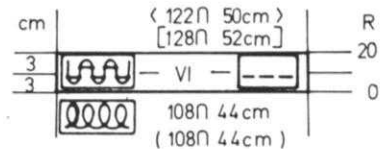

NECKBAND: VI

Cast on 108 (108) [122] /128/ sts. and work 20 rows Ribbing. Bind off. (Or you can remove onto waste yarn and sew to neckline, fold to the wrong side and sew in place.

DK 919

WOMAN'S TWINSET

SIZES: 7/8 (10/12) [14/16] /18/20/
 YARN: Pingouin Qued
 GRAMS: 550 550 650 650
 TENSION: 8 or 9
 GAUGE: 12 sts. 17 rows = 5 cm (2")

FINISHING: See General Instructions.

PULLOVER FRONT & BACK: See Instructions for DK 918.

PULLOVER SLEEVES: III

Cast on 62 (72) [84] /96/ sts. and work 20 rows Ribbing. Continue in Stockinette stitch. **ON EACH SIDE, increase 1 st.**

every 4th row 4x, every 2nd row 1x for all sizes. After Row 32, SHAPE CAP: PLEASE FOLLOW THE INSTRUCTIONS FOR CAP SHAPING ON EACH SIDE BY FOLLOWING THE CHART FOR YOUR SIZE. Make NECKBAND for Pullover same as DK 918.



The Pullover for this Twin Set is the same one as DK 918. Follow the instructions for the Back and Front and use the Short Sleeves given here in place of the long sleeves. All stockinette stitch with K1, P1 Ribbing for the Bands.

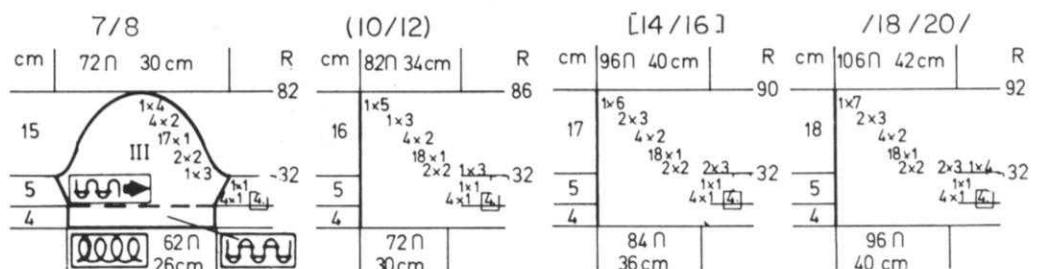

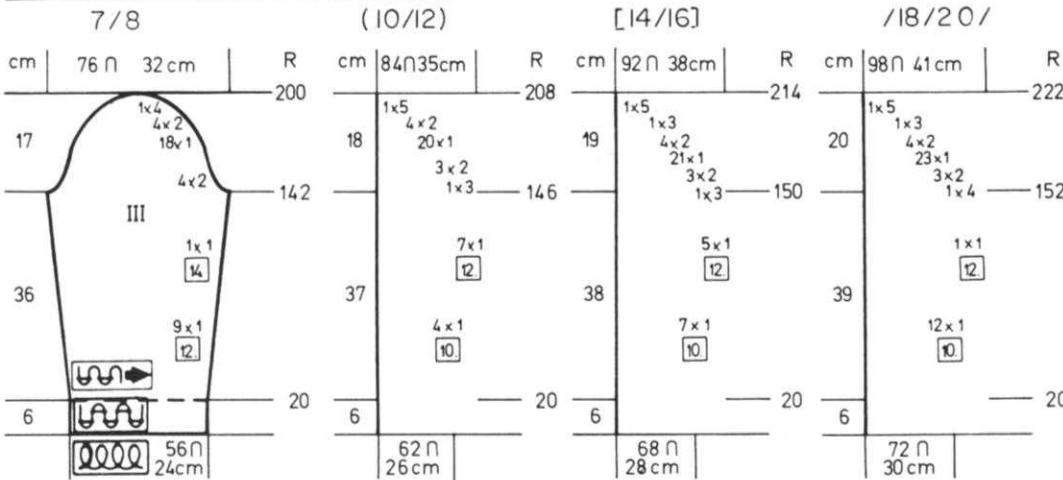

Cast on 56 (62) [68] /72/ sts. and work 20 rows Ribbing. Continue in Stockinette stitch. ON EACH SIDE, increase 1 st. every 12th row 9x, every 14th row 1x. (every 10th row 4x, every 12th row 7x). [every 10th row 7x, every 12th row 5x]. /every 10th row 12x, every 12th row 1x/. After Row 142 (146) [150] /152/ SHAPE CAP: Please FOLLOW THE INSTRUCTIONS FOR SHAPING THE CAP ON EACH SIDE by FOLLOWING THE INSTRUCTIONS ON THE CHART FOR YOUR SIZE.

CARDIGAN FRONT: I Make 1, reverse 1.

Cast on 59 (62) [68] /76/ sts. and work 20 rows Ribbing. Continue in Stockinette stitch. Knit to Row 128 (132) [136] /140/.

SHAPE ARMHOLE SAME AS THE BACK then knit to Row 177 (183) [191] /197/. SHAPE NECK: Bind off 6 sts. 1x, 2 sts. 4x, 1 st. 4x. (7 sts. 1x, 2 sts. 4x, 1 st. 4x).

[6 sts. 1x, 2 sts. 4x, 1 st. 6x]. /7 sts. 1x, 2 sts. 6x, 1 st. 4x/. After Row 200 (208) [214] /222/ SHAPE SHOULDER same as the back.

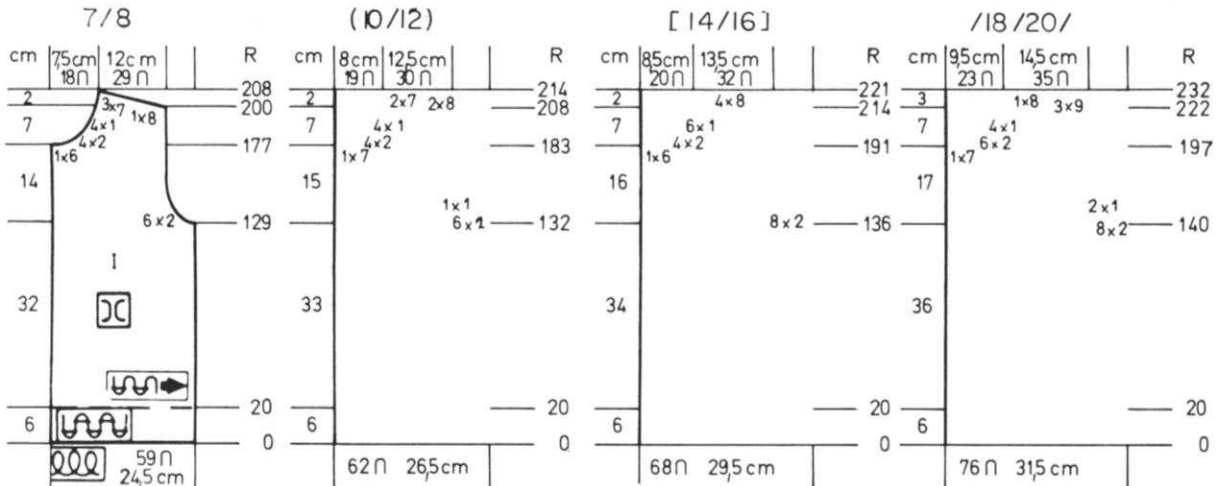

CARDIGAN BACK: II

Cast on 118 (124) [136] /152/ sts. and work 20 rows Ribbing. Continue in Stockinette stitch. Knit to Row 129 (132) [136] /140/. SHAPE ARMHOLE: ON EACH SIDE, bind off

2 sts. 6x. (2 sts. 6x, 1 st. 1x). [2 sts. 8x]. /2 sts. 8x, 1 st. 2x/. Knit to Row 200 (208) [214] /222/. SHAPE SHOULDER: ON EACH SIDE, bind off

8 sts. 1x, 7 sts. 3x. (8 sts. 2x, 7 sts. 2x). [8 sts. 4x]. /9 sts. 3x, 8 sts. 1x/. After Row 208 (214) [221] /232/ bind off the remaining sts.

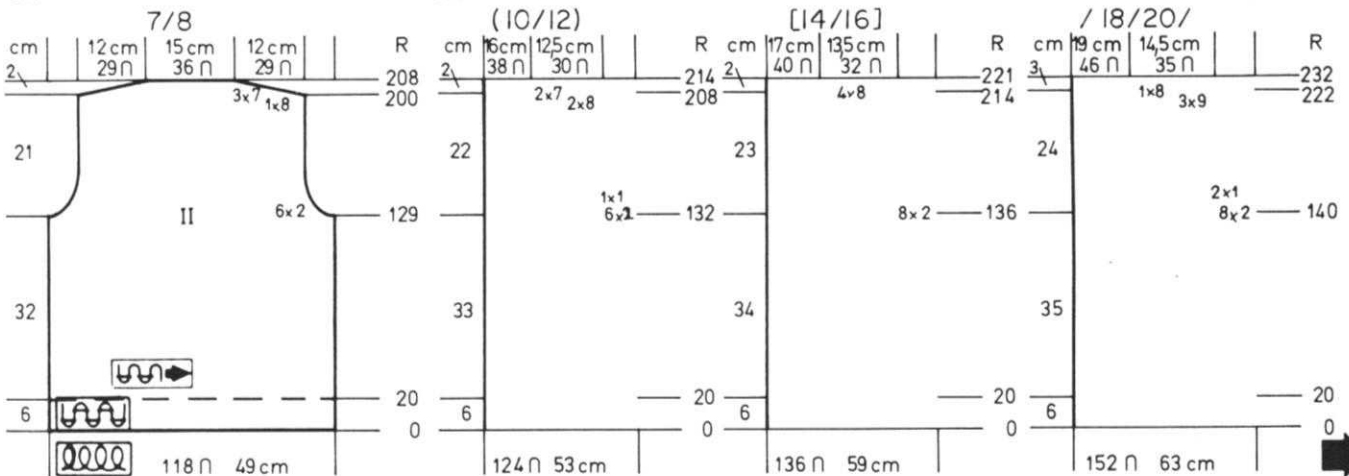

DK 919

CARDIGAN NECKBAND:

Cast on 86 (91) [96] /100/ sts. and work 20 rows Ribbing. Sew Shoulders of front and back first, then pick up the sts. around neck edge and bind off.

CARDIGAN FRONT BANDS.

MAKE BUTTON BAND FIRST, MARK FOR BUTTONHOLES, then knit the BUTTONHOLE BAND.
Cast on 137 (142) [146] /153/ sts. and work 9 rows Ribbing. Work 1 row Tension 10 then work 10 rows more of Ribbing. Pick up the sts. along front edge and bind off.
REPEAT for BUTTONHOLE BAND but make buttonholes 3 sts. wide spaced evenly across after Row 5, 15.

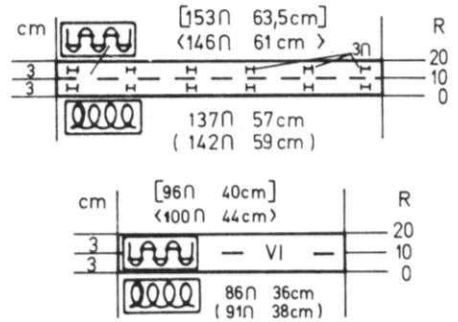

DK 920

WOMAN'S JOGGING SUIT

SIZES: 8/10 (12/14)
YARN: Amore
GRAMS: color 1 550 600, color 2 50 50
TENSION: 7 to 9
GAUGE: 14 sts. 18 rows = 5 cm (2")

Stockinette stitch with K2, P2
Ribbing in color 2 for the Bands.

FINISHING: See General Instructions.

PANTS BACK: XII Make 1, reverse 1.
FOR BOTH SIZES.

Cast on 76 sts. with waste yarn and work Stockinette stitch. After knitting 8 to 10 rows, change to garment yarn and put Counter at 0.
ON SIDE EDGE, increase 1 st. every 40th row 5x and AT THE SAME TIME, ON INNER EDGE, after Row 130, increase 1 st. every 40th row 2x, every 20th row 2x, every 4th row 5x.
After Row 233, SHAPE CROTCH. Bind off 3 sts. 2x, 2 sts. 4x, 1 st. 6x.
After Row 346, change to Ribbing and work to Row 358. Bind off.

PANTS FRONT: XI Make 1, reverse 1.

Cast on 70 sts. with Waste yarn as you did for the back and work Stockinette stitch. Work same as the back to Row 234.
SHAPE CROTCH: Bind off 3 sts. 2x, 2 sts. 2x, 1 st. 4x. Knit to Row 346, change to Ribbing and work to Row 358. Bind off.

PULLOVER BACK:

Cast on 140 (150) sts. with color 2 and work 22 rows Ribbing. Continue in Stockinette stitch with color 1.
Knit to Row 148.
SHAPE ARMHOLE: ON EACH SIDE, bind off 3 sts. 1x, 2 sts. 6x. (2 sts. 9x).
Knit to Row 202 (206).
Bind off the 24 (22) sts., put the needles on the left into holding position and complete the right side first.
*SHAPE SHOULDER AND NECK AT THE SAME TIME.
FOR SHOULDER, bind off 9 sts. 3x, 8 sts. 1x, (7 sts. 2x, 8 sts. 3x),

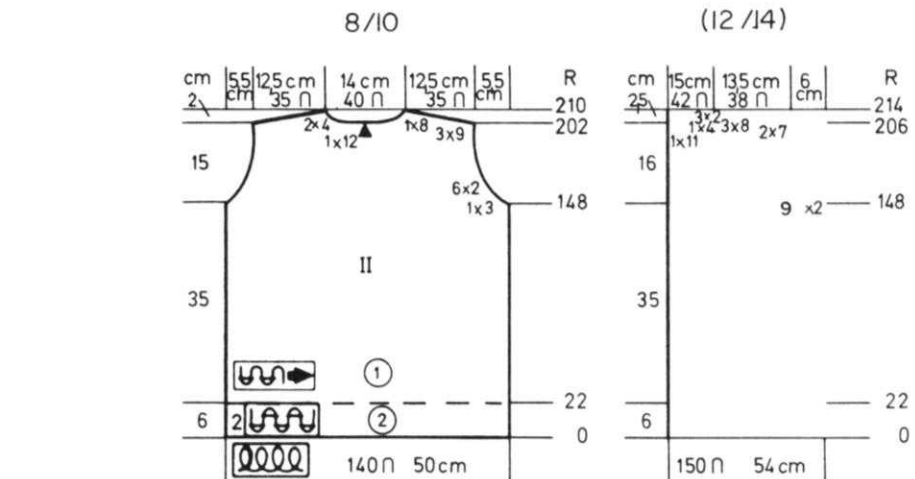
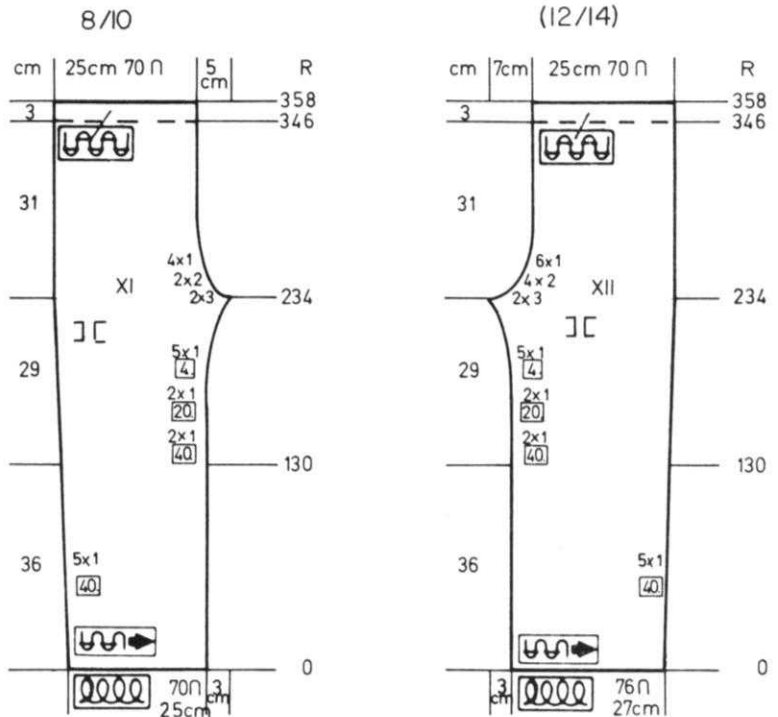

FOR NECK, bind off 4 sts. 2x. (4 sts. 1x, 2 sts. 3x).
Bring the needles on the left into working position, knit 1 row to

the left side, turn the Row Counter back to 202 (206) and complete the left half. Follow the instructions from *.

DK 920

LEG BANDS: VIII

Hang the open sts. of the Legs of Pants back onto the machine decreasing to 70 sts. With color 2, work 12 rows Ribbing. Bind off.

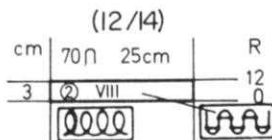

PULLOVER NECKBAND: VI-VIII

Cast on 112 (118) sts. with color 2 and work 16 rows Ribbing. Remove onto contrast waste yarn.

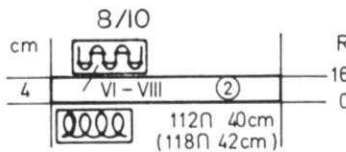

SLEEVES: III Make 1, reverse 1.

Cast on 86 (90) sts. with color 2 and work 16 rows Ribbing. Continue in Stockinette stitch with color 1. ON EACH SIDE, increase 1 st. every 20th row 7x for both sizes. After Row 164, SHAPE CAP: PLEASE FOLLOW THE DIFFERENT BIND-OFFS ON EACH SIDE by following the Chart for your size. After Row 206 (210) Knit even to Row 245 (253) then work SHORT ROWS: ON OPPOSITE SIDE OF SLIDE, put into holding position 7 sts. 2x, 8 sts. 1x. Bring all the needles back into working position and bind off.

8/10

(12/14)

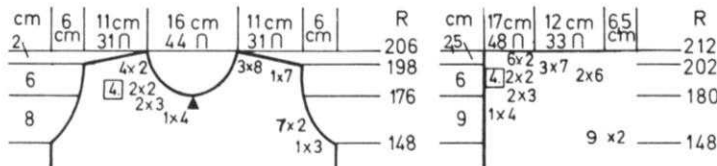

PULLOVER FRONT: I

Work the front the same as the back to Row 148. SHAPE ARMHOLE: ON EACH SIDE, bind off 3 sts. 1x, 2 sts. 7x. (2 sts. 9x). Knit to Row 176 (180). Bind off the center 8 sts., put the needles on the left into holding position and complete the right side first. *ON NECK SIDE, bind off 3 sts. 2x, 2 sts. every 4th row 2x, 2 sts. every 2nd row 4x. (3 sts. 2x, 2 sts. every 4th row 2x, 2 sts. every 2nd row 6x). After Row 198 (202), SHAPE SHOULDER: Bind off 7 sts. 1x, 8 sts. 3x. (6 sts. 2x, 7 sts. 3x). Bring the needles on the left into working position, knit 1 row to the left side, turn the Row Counter back to 176 (180) and complete the left half. Follow the instructions from *.

8/10

(12/14)

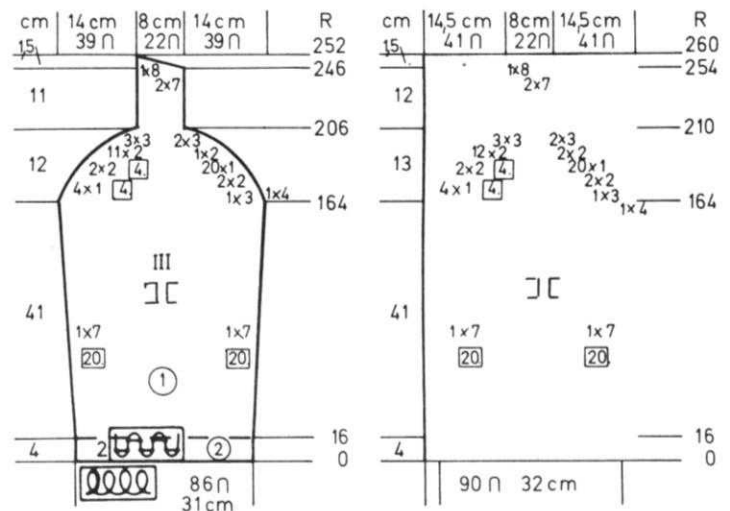

HP 921

MAN'S JACKET

SIZES: 38 (40/42)
YARN: Amore
GRAMS: 900 950
TENSION: Pat. 9 K1, P1 Rib. 5/5
GAUGE: Pat. 13 sts. 26 rows = 5 cm (2")
K1, P1 Rib. 19 sts. 21 1/2 rows "

Half Fisherman's Rib is used for this Jacket with K1, P1 Ribbing for the Bands. See your Ribber Instruction Manual for Half Fisherman's Rib (or English Rib).

FINISHING: See General Instructions.

BACK: II

Cast on 136 (144) sts. and work 6 rows Ribbing. Continue in HALF FISHERMAN'S RIB (ENGLISH RIB). Knit to Row 202 (208). SHAPE RAGLAN: ON EACH SIDE, bind off Every 2nd row 1 st. 28x, then every 4th row 1 st. 25x. (Every 2nd row 1 st. 36x, then every 4th row 1 st. 21x. After Row 358 (364), bind off the remaining sts.

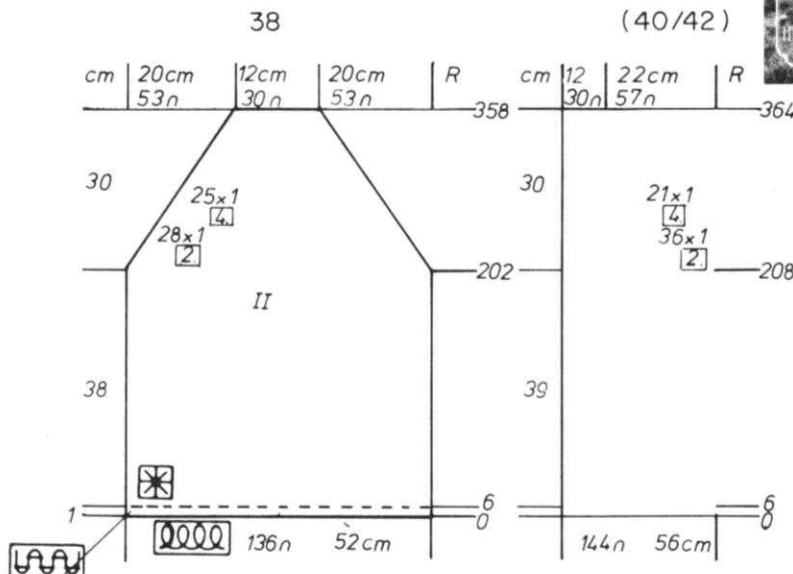

HP 921

FRONT: I Make 1, reverse 1.

Cast on 52 (58) sts. and work 6 rows K1, P1 Ribbing. Continue in Half Fisherman's Rib (English Rib).

Knit to Row 202 (208). SHAPE NECK AND RAGLAN AT THE SAME TIME.

FOR NECK, decrease 1 st. every 30th row 5x for both sizes.

FOR RAGLAN, decrease 1 st. every 2nd row 19x, every 4th row 28x. (every 2nd row 33x, every 4th row 20x).

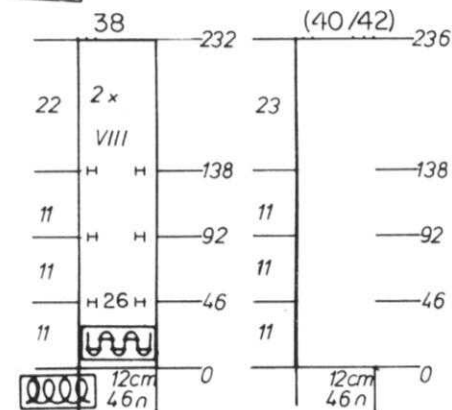
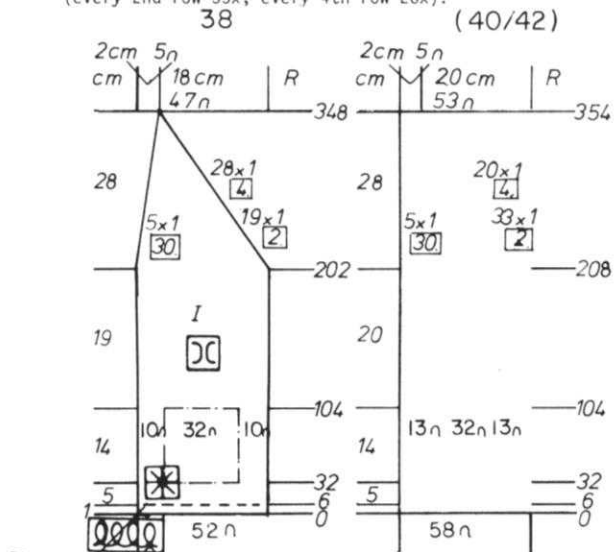

SLEEVES: III Make 1, reverse 1.

Cast on 75 (81) sts. and work 6 rows K1, P1 Ribbing. Continue in Rib Pattern same as front and back.

ON EACH SIDE, increase 1 st. every 12th row 8x (9x), then every 14th row 8x (8x).

After Row 224, SHAPE RAGLAN:

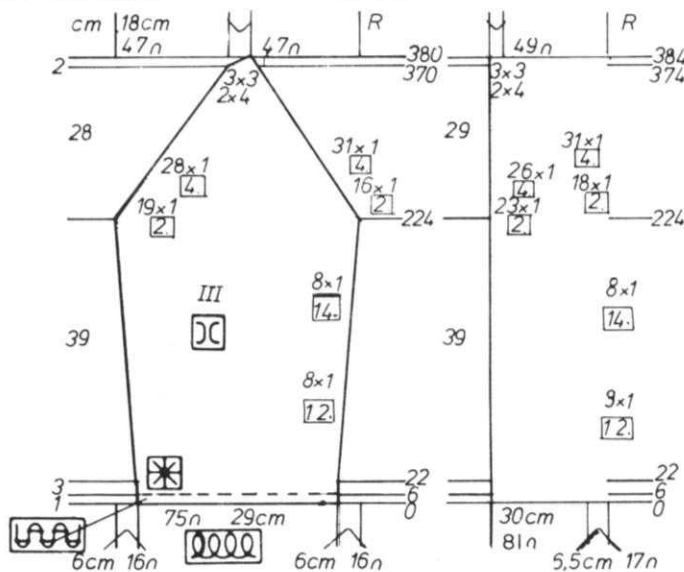

FRONT BANDS: Make 1 with and 1 without BUTTONHOLES.

Cast on 46 sts and work K1, P1 Ribbing. MAKE BUTTONHOLES ON THE ROWS SHOWN ON CHART - Skip 5 sts. on each side, and make buttonholes over the next 5 sts. (26 left in middle). After Row 232 (236), bind off.

POCKET: Make 2.

Cast on 32 sts. and work in Rib Pattern same as front and back. After Row 72, bind off or remove onto waste yarn. When garment is completed, sew pockets in place as shown on the Chart.

PLEASE FOLLOW THE DIFFERENT BIND-OFFS ON EACH SIDE as shown on the Chart for your size.

After Row 370 (374) Work SHORT ROWS. ON OPPOSITE SIDE OF SLIDE, put into holding position, 4 sts. 2x, 3 sts. 3x for both sizes. After Row 380 (384), bring all the needles into working position and bind off.

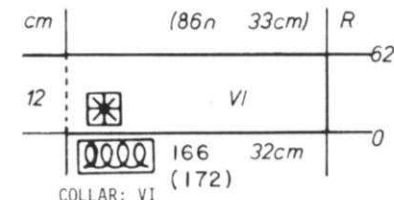

COLLAR: VI

Cast on 166 (172) sts. and work in Pattern same as front and back. After Row 62, bind off, or remove onto waste yarn.

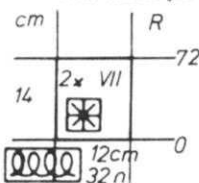

KK 922

CHILD'S PULLOVER

SIZES: 4/6 (8) [10/12]

YARN: Fortissima

GRAMS:

color 1 150 200 250

color 2 100 150 200

TENSION: 7 to 8

GAUGE: 14 sts. 18 rows = 5 cm (2")

The Pattern is a Rib of P2, K3 with 2 rows color 1, 2 rows color 2. Bands are K1, P1 Ribbing.

FINISHING: See General Instructions.

NECKBAND:

Cast on 120 (140) [150] sts. with color 1 and work 10 rows K1, P1 Ribbing. Bind off or remove onto waste yarn.

FRONT: I

Work the front the same as the back to Row 94 (112) [122]. Put half the sts. on the left into holding position and complete the right side first.

*ON NECK SIDE, decrease 1 st. every 2nd row 1x, every 4th row 15x, (every 4th row 12x, every 5th row 6x), [every 4th row 20x], AT THE SAME TIME, after Row 102 (120)



KK 922

[130], SHAPE ARMHOLE SAME AS THE BACK.
After Row 148 (182) [194], SHAPE SHOULDER same as the back.
Bring the needles on the left into working position, knit 1 row to the left side, turn the Row Counter back to 94 (112) [122] and complete the left half. Follow the instructions from *.

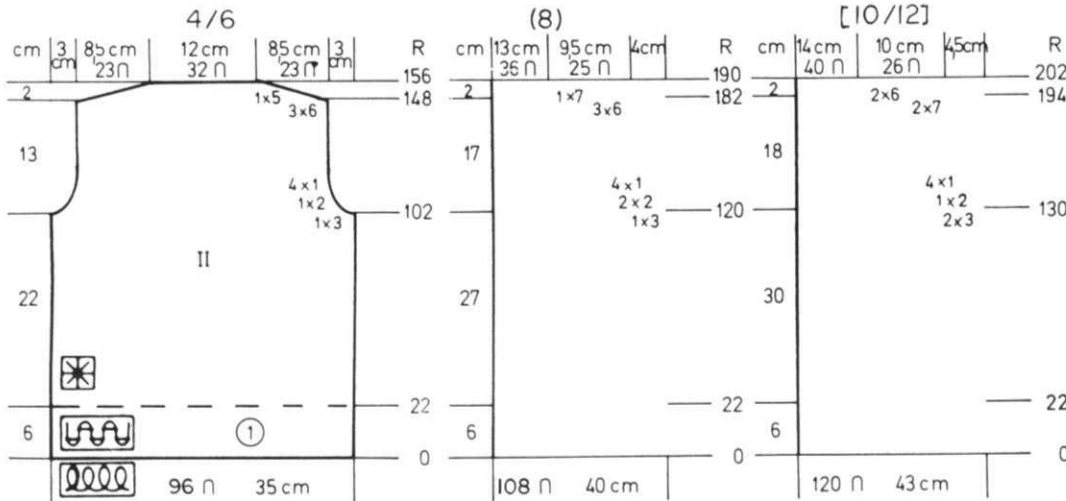
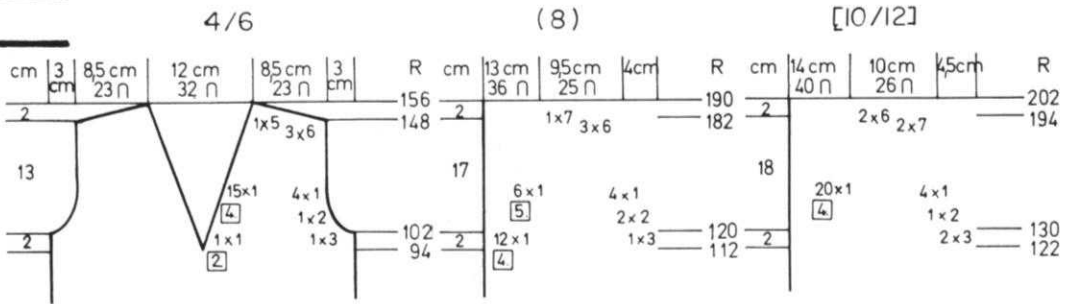

BACK: II
Cast on 96 (108) [120] sts. with color 1 and work 22 rows K1, P1 Ribbing.
Set up the needles for Pattern of P2, K3 and change color every 2 rows.
Knit in Pattern to Row 102 (120) [130].
SHAPE ARMHOLE: ON EACH SIDE, bind off 3 sts. 1x, 2 sts. 1x, 1 st. 4x. (3 sts. 1x, 2 sts. 2x, 1 st. 4x). [3 sts. 2x, 2 sts. 1x, 1 st. 4x]. Knit to Row 148 (182) [194].
SHAPE SHOULDER: ON EACH SIDE, bind off 6 sts. 3x, 5 sts. 1x. (6 sts. 3x, 7 sts. 1x). [7 sts. 2x, 6 sts. 2x].
After Row 156 (172) [202], bind off the remaining sts.

SLEEVES: III

Cast on 58 (64) [68] sts. with color 1 and work 22 rows Ribbing.
Set into Pattern same as front and back and continue in 2 rows color 1, 2 rows color 2.
ON EACH SIDE, increase 1 st. every 16th row 5x, every 14th row 2x. (every 8th row 7x, every 10th row 6x). [every 8th row 7x, every 10th row 6x].
Knit to Row 130 (138) [138].
SHAPE CAP: PLEASE FOLLOW THE BIND OFFS ON EACH SIDE as shown on the CHART FOR YOUR SIZE. Sleeve is completed after Row 162 (182) [186].

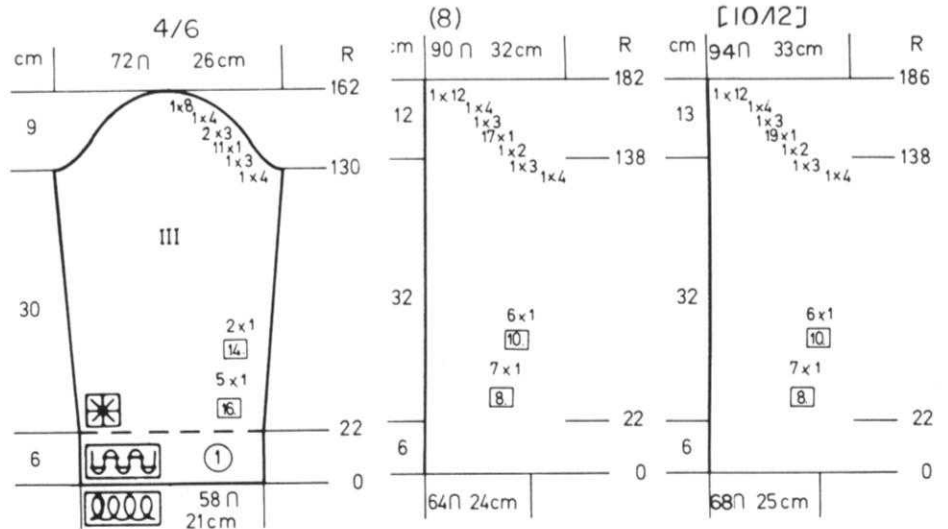

DK 923

WOMAN'S PULLOVER

SIZES: 8 (10) [12]
YARN: Amore
GRAMS:
color 1 400 450 450
color 2 100 100 100
color 3 100 100 100
color 4 100 100 100
TENSION: 10

GAUGE: 13 sts. 20 rows = 5 cm (2")
IMPORTANT: - Card is punched for 4-Color Changer. When doing 6 plain rows in main color, you must cancel the Color Changer. (Little Button on side of Color Changer).
Norwegian Technique is used.
Bands are K1, P1 Ribbing.

FRONT: I

The front is worked the same as the back to Row 140 (144) [148].
Divide in the center. Put the needles on the left into holding

position and complete the right side first.

*ON NECK SIDE (don't forget to mark row 160 (164) [168] for setting in sleeves) decrease 1 st. every 4th row 10x, every 6th row 10x.

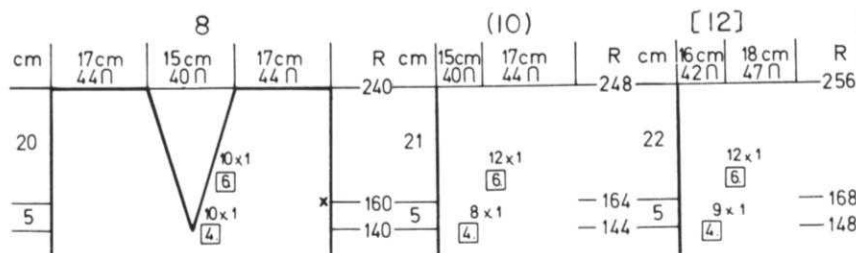

DK 923

(every 4th row 8x, every 6th row 12x).
 [every 4th row 9x, every 6th row 12x].
 After Row 240 (248) [256], bind off
 the remaining sts.
 Bring the needles on the left into
 working position, knit 1 row in
 Pattern to the left side, turn the
 Row Counter back to 140 (144) [148]
 and complete the left half. Follow
 the instructions from *.

BACK: II

Cast on 128 (128) [136] sts. with
 color 1 and work 36 (40) [40] rows
 Ribbing.
 Continue in Pattern.
 Knit to Row 160 (164) [168].
 Mark each side with bit of yarn
 for setting in sleeves.
 Knit to Row 240 (248) [256].
 Bind off.

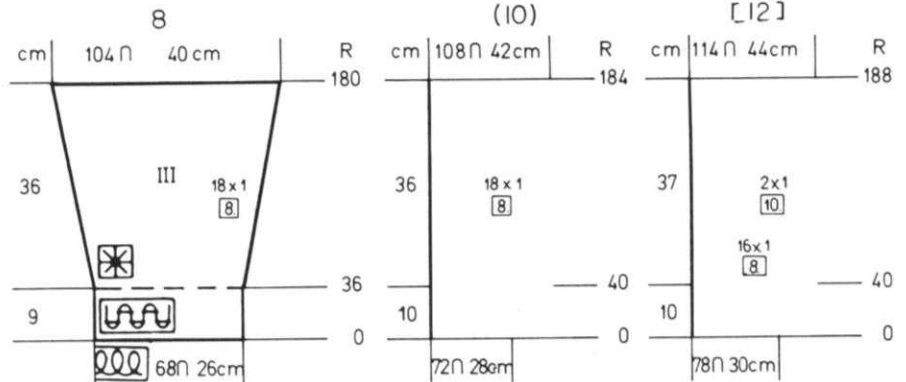
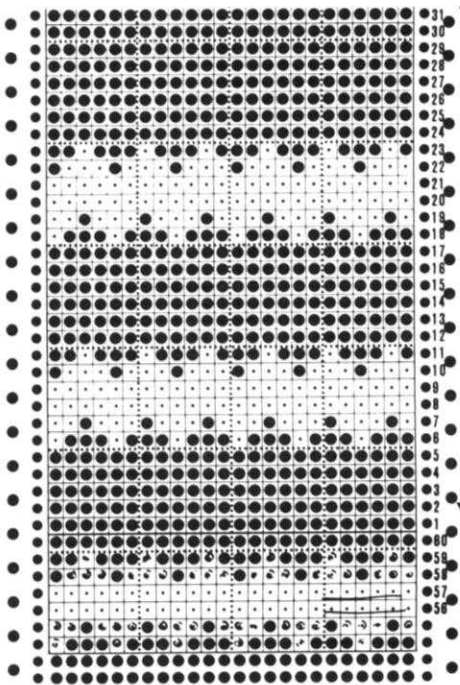
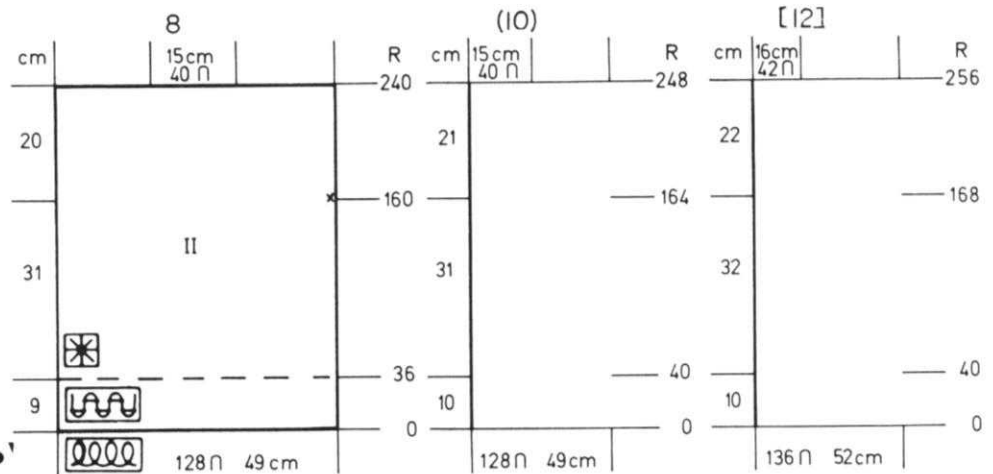

SLEEVES: III

Cast on 68 (72) [78] sts. with
 color 1 and work 36 (40) [40] rows
 Ribbing.
 Continue in Pattern.
 ON EACH SIDE, increase 1 st.
 every 8th row 18x.
 (every 8th row 18x).

[every 8th row 16x, every 10th
 row 2x].
 After Row 180 (184) [188], bind off.

NECKBAND:

Cast on 200 sts. and work 12 rows
 Ribbing. Bind off or remove onto
 waste yarn.

DK 924

TEENAGER PULLOVER

SIZES: 5/6 (7/8) [10/12]

YARN: Amore

GRAMS:

color 1	450	450	500
color 2	50	50	50
color 3	50	50	50
color 4	50	50	50

TENSION: 8 to 10

GAUGE: 13 sts. 18 rows = 5 cm (2")

Stockinette stitch with a Norwegian
 Design. Bands are K1, P1 Ribbing.

FINISHING: See General Instructions.

NOTE: When working the Norwegian
 Design, cut the yarn each time
 because of the wide spacing in
 changes of color.

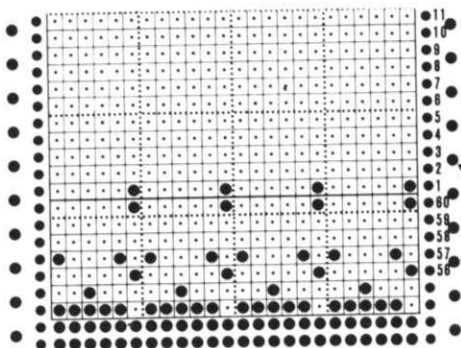

BEGIN HERE

- 2 rows color 1 + 2
- 2 rows Color 1 + 3
- 2 rows color 1
- 2 rows color 1 + 4



BACK: II

Cast on 112 (122) [130] sts. with color 1 and work 36 rows Ribbing. Continue in Stockinette stitch with Norwegian Design as in the instructions.

Work the Norwegian Design AFTER ROWS 54, 116, 170.

After Row 151 (155) [158], SHAPE ARMHOLE. ON EACH SIDE, bind off 3 sts. 1x, 2 sts. 1x, 1 st. 2x. (3 sts. 1x, 2 sts. 2x, 1 st. 2x). [3 sts. 1x, 2 sts. 2x, 1 st. 2x]. After Row 218 (226) [234], bind off the center 32 sts., put the needles on the left into holding position and complete the right side first.

*SHAPE SHOULDER AND NECK AT THE SAME TIME.

FOR SHOULDER, bind off 4 sts. 2x, 5 sts. 4x, (6 sts. 1x, 5 sts. 5x), [5 sts. 1x, 6 sts. 5x],

FOR NECK, bind off 3 sts. 1x, 2 sts. 1x, for all sizes.

Bring the needles on the left into working position, knit 1 row to the left side, turn the Row Counter back to 218 (226) [234] and complete the left half. Follow the instructions from *.

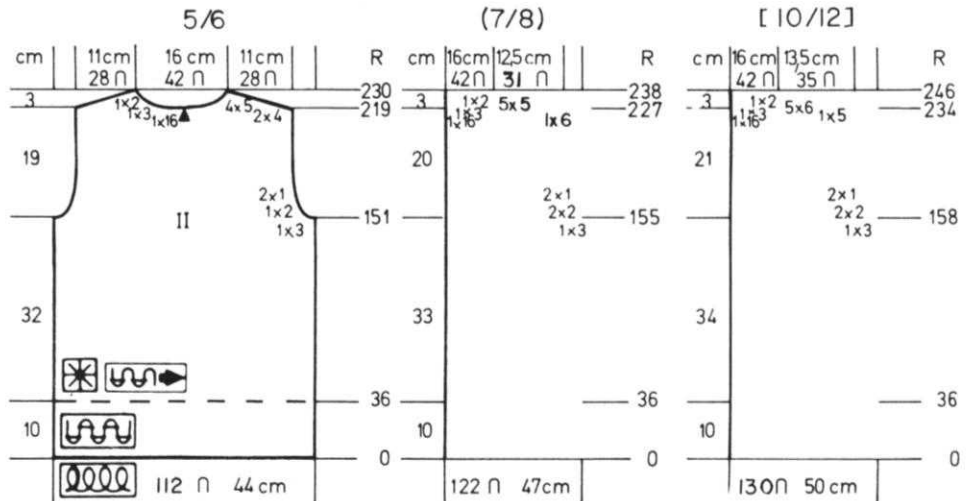

SLEEVES: III

NOTE: Work the Norwegian Design after Rows 76, 130, 184. Cast on 76 (78) [80] sts. with color 1 and work 36 rows Ribbing. Continue in Stockinette stitch with Norwegian Design after the given rows.

ON EACH SIDE, increase 1 st. every 16th row 7x, every 18th row 1x. (every 16th row 5x, every 18th row 3x). [every 16th row 3x, every 18th row 5x].

After Row 166 (170) [174], SHAPE CAP.

PLEASE FOLLOW THE INSTRUCTIONS FOR SHAPING THE CAP ON EACH SIDE, using the CHART FOR YOUR SIZE.

FRONT: I

Work the front the same as the back to Row 136 (140) [144].

Divide in the center, put the needles on the left into holding position and complete the right side first.

*ON NECK SIDE, decrease 1 st. every 4th row 16x, every 6th row 5x. (every 4th row 15x, every 6th row 6x). [every 4th row 14x, every 6th row 7x].

AT THE SAME TIME, after Row 150 (154) [158], SHAPE ARMHOLE SAME AS THE BACK.

After Row 218 (226) [234], SHAPE SHOULDER same as the back.

Bring the needles on the left into working position, knit 1 row to the left side, turn the Row Counter back to 136 (140) [144] and complete the left half. Follow the instructions from *.

NECKBAND: VI

Cast on 200 sts. and work in Ribbing. ON EACH SIDE, on every 2nd row, decrease 2 sts. 6x. After Row 14, bind off or remove onto contrast waste yarn.

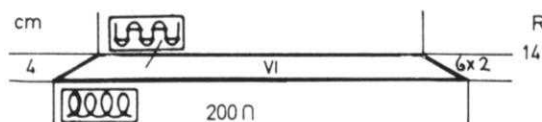
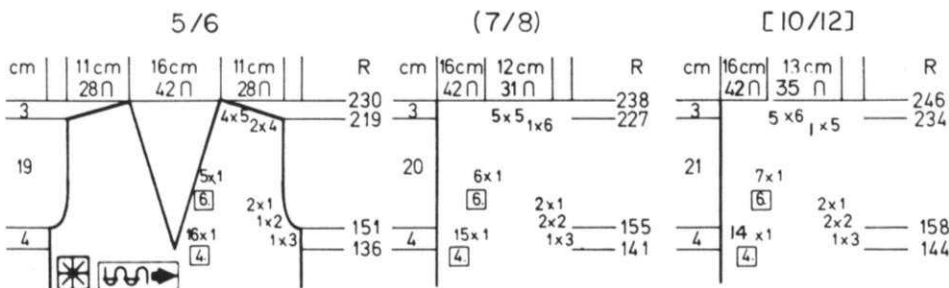
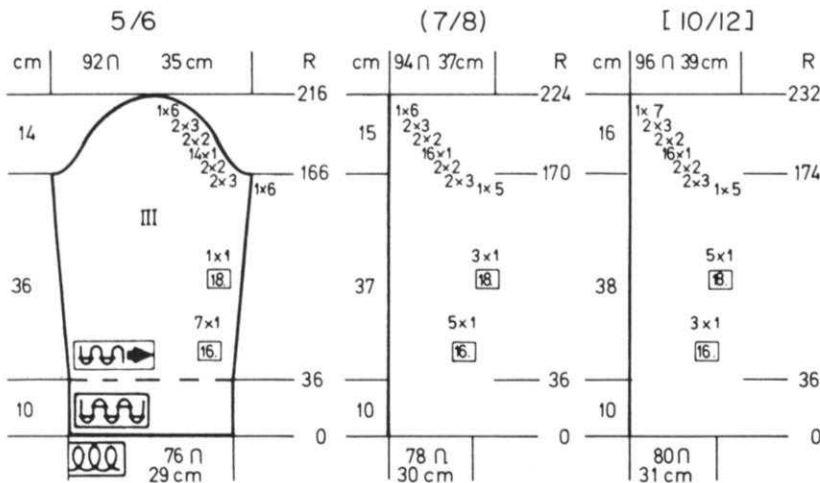

DK 925



WOMAN'S SKIRT & PULLOVER

SIZES: 7/8 (10/12 [14/16])
YARN: Amore

GRAMS:
color 1 750 800 850
color 2 250 250 300

PLUS 1 Spool of Sewing Thread
TENSION: 8 to 9 for Skirt

$\frac{7}{7}$ = Pullover

GAUGE: 13 sts. 20 rows = 5 cm (2")
= Skirt
17 sts. 25 rows = 5 cm (2")
= Pullover

The Skirt is Stockinette stitch with color 1. The Pullover is HALF FISHERMAN'S (English) RIB. See your Ribber Instruction Manual. Bands are K1, P1 Ribbing.

FINISHING: See General Instructions.

FRONT: I

Work the front the same as the back to Row 192 (204) [214]. Divide in the center, put the needles on the left into holding position and complete the right side first. *SHAPE ARMHOLE AND NECK AT THE SAME TIME.

FOR NECK, decrease

1 st. every 2nd row 28x, every 4th row 10x.

(1 st. every 2nd row 36x, every 4th row 7x).

[1 st. every 2nd row 33x, every 4th row 11x].

FOR ARMHOLE, bind off 4 sts. for all sizes, then decrease 1 st.

every 2nd row 18x, every 4th row 15x. (every 2nd row 28x, every 4th row 10x).

[every 2nd row 33x, every 4th row 11x].

Bring the needles on the left into working position, knit 1 row to the left side, turn the Row Counter back to 192 (204) [214] and complete the left half. Follow the instructions from *.

SKIRT FRONT & BACK: 2 sections the same.

Cast on 130 (138) [148] sts. with color 1 AND SEWING THREAD TOGETHER. Work Stockinette stitch.

You may hang the hem after Row 24 and ON EACH SIDE, decrease 1 st. every 34th row 8x for all sizes.

After Row 292 (308) [324], mark the next row then knit to Row 316 (332) [348]. Hang the hem using the marked row as guide then bind off.

PULLOVER BACK:

Cast on 150 (170) [184] sts. with color 1 and work 48 rows Ribbing. Continue in Half Fisherman's Rib. Change colors as shown on the Chart.

After Row 192 (204) [214], SHAPE RAGLAN: ON EACH SIDE, bind off 4 (3) [5] sts. then decrease 1 st. every 2nd row 39x, then every 4th row 8x.

(every 2nd row 58x).

[every 2nd row 63x].

After Row 302 (320) [340], bind off the remaining sts.

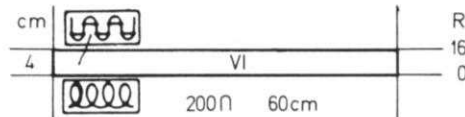

NECKBAND: VI

Cast on 200 sts. and work 16 rows Ribbing. Bind off or remove onto contrast waste yarn.

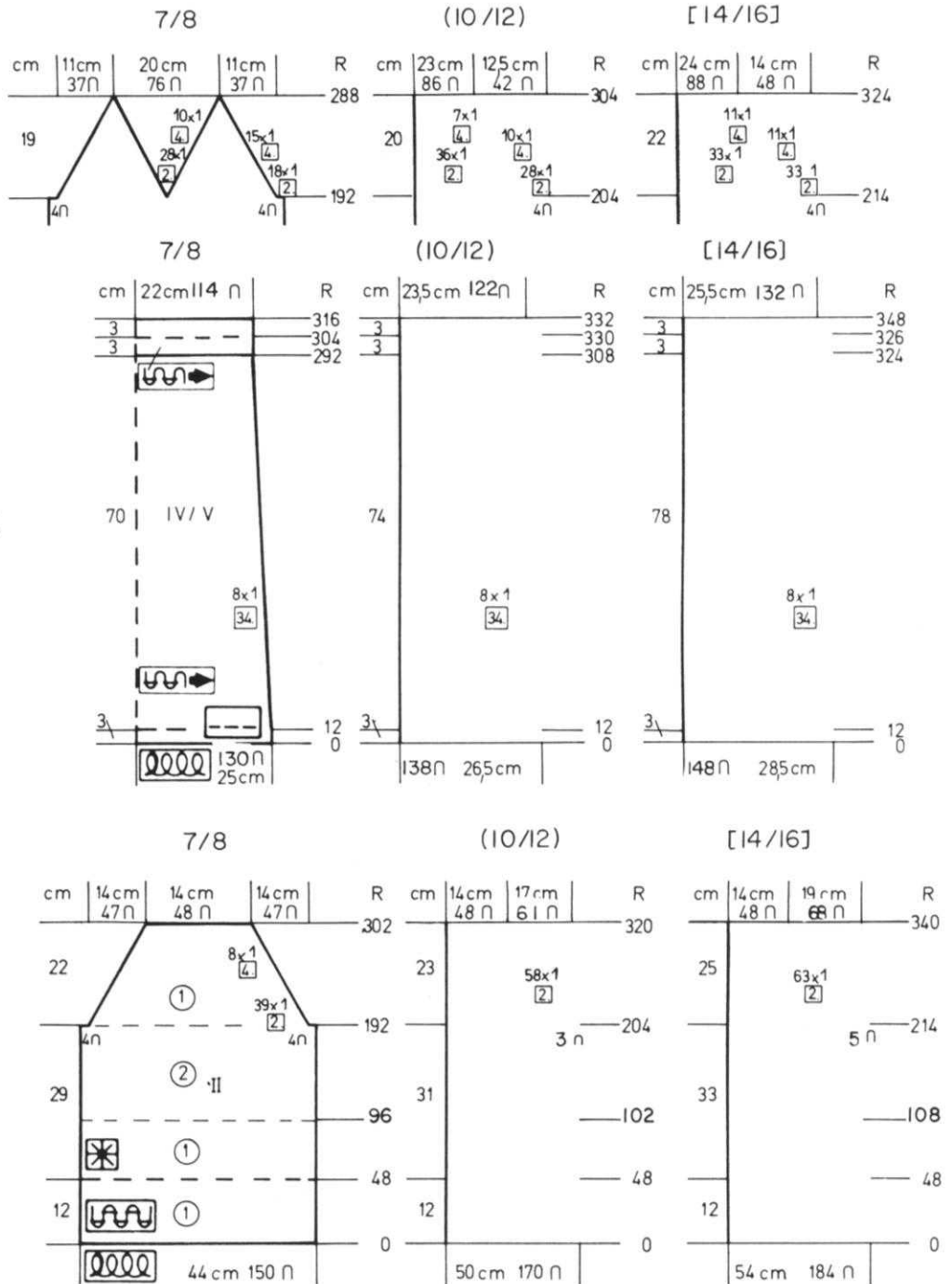

DK 925

7/8

(10/12)

[14/16]

SLEEVES: III Make 1, reverse 1.

Cast on 96 (104) [110] sts. and work 48 rows Ribbing. Continue in Pattern. ON EACH SIDE increase 1 st. every 10th row 14x. [every 10th row 16x]. [every 8th row 19x]. After Row 192 (204) [214], SHAPE RAGLAN. PLEASE FOLLOW THE INSTRUCTIONS FOR THE DIFFERENT BIND-OFFS ON EACH SIDE AS SHOWN ON THE CHART FOR YOUR SIZE. After Row 287 (303) [323], work SHORT ROWS. ON OPPOSITE SIDE OF SLIDE, put into holding position, 5 sts. 3x, 4 sts. 5x for all sizes. Bring all the needles back into working position and bind off.

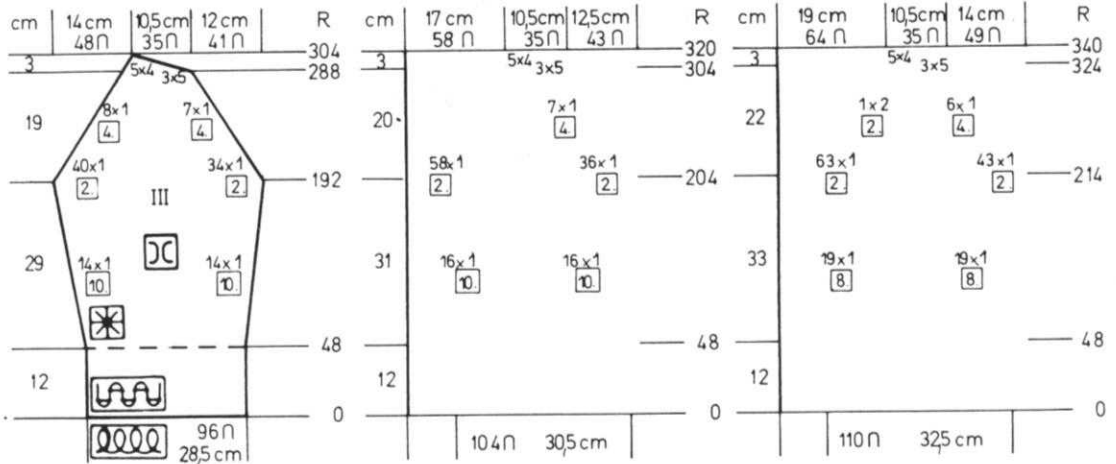

HP 926

MAN'S PULLOVER

SIZES: 34/36 (38/40) [42/44]

YARN:

GRAMS:

color 1 550 600 650
color 2 150 200 200

TENSION: 7 to 9

GAUGE: 13 sts. 18 rows = 5 cm (2")

Stockinette stitch and SHORT ROWS for the design in different colors. Bands are K1, P1 Ribbing.

FINISHING: See General Instructions.

IMPORTANT NOTE:

Diagonal Stripes using SHORT ROW METHOD.

Begin at Row 80 (84) [88]. Put left half of the garment into holding position, plus 1 st. Of the remaining sts., ON EVERY 2nd ROW, put into holding position on the LEFT, 2 sts. until all are in holding. REPEAT for the left half, putting the sts. on the RIGHT into holding. Put 2 needles in the center into

working position and with color 2, then ON BOTH SIDES bring back into working position 2 needles until Row 40. Put the stitches on the left into holding position and continue SHORT ROWS on the RIGHT. See Chart and don't forget the Armhole Raglan Shaping. REPEAT on the left side, then start again in the center with color 1 and REPEAT the SHORT ROWS.

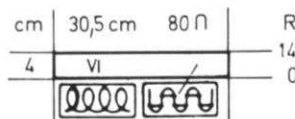

NECKBAND: VI

Cast on 80 sts. and work 14 rows Ribbing. Bind off or remove onto contrast waste yarn.

SLEEVES: IIII

Cast on 82 (84) [88] sts. with color 1 and work 28 rows Ribbing. Continue in Stockinette stitch with color stripe as shown on the Chart.

ON EACH SIDE, increase 1 st. every 4th row 9x, every 6th row 17x. (every 4th row 18x, every 6th row 12x). [every 4th row 23x, every 6th row 10x]. After Row 166 (172) [180], SHAPE RAGLAN: PLEASE FOLLOW THE INSTRUCTIONS FOR THE DIFFERENT BIND-OFFS

ON EACH SIDE AS PER THE CHART IN YOUR SIZE. After Row 233 (247) [261], work SHORT ROWS. On OPPOSITE SIDE OF SLIDE, put into holding position 9 sts. 2x, 10 sts. 2x for all sizes. Bring all the needles back into working position and bind off.

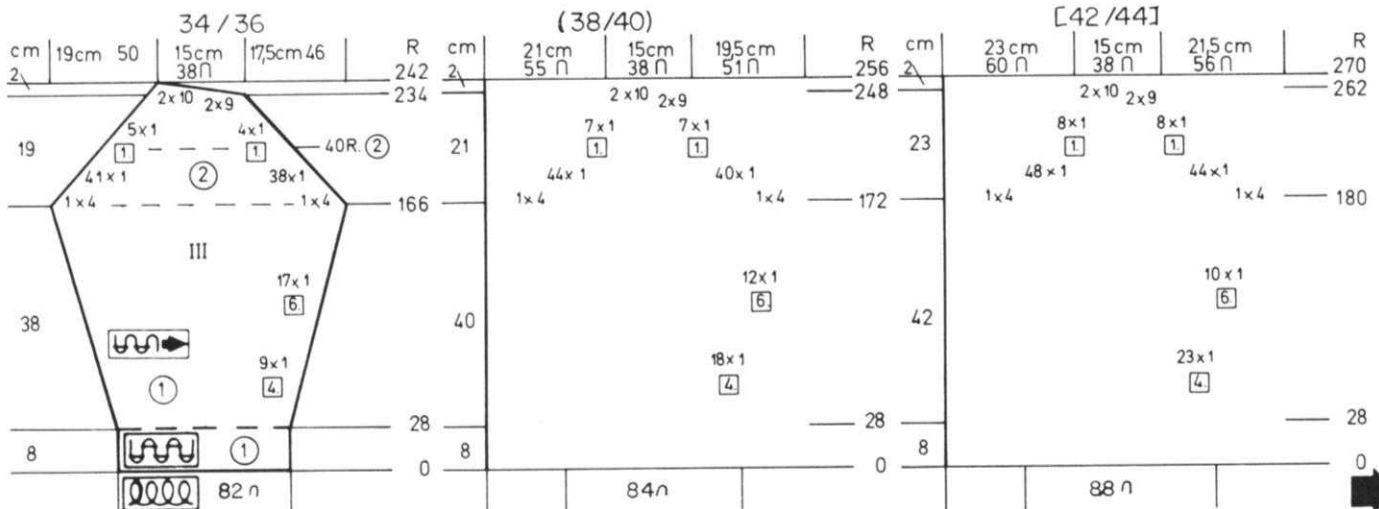

HP 926

FRONT: I

The front is worked the same as the back to Row 144 (152) [162].
SHAPE ARMHOLE: ON EACH SIDE, bind off 4 sts. for all sizes, then ON EACH SIDE, decrease 1 st. every 2nd row 38x (40x) [44x] and ON EVERY ROW, decrease 1 st. 4x (7x) [8x].
 AT THE SAME TIME, after Row 202 (216) [234], bind off the center 10 sts., put the needles on the left into holding position and complete the right side first.

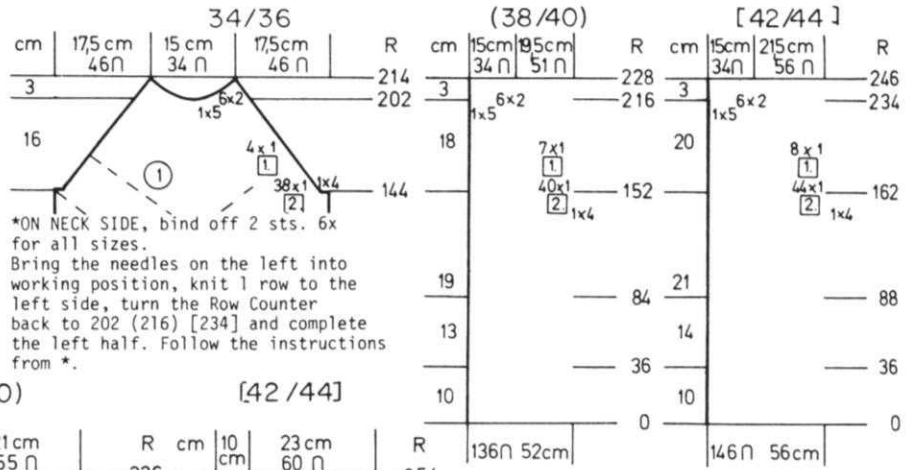

34/36

(38/40)

[42/44]

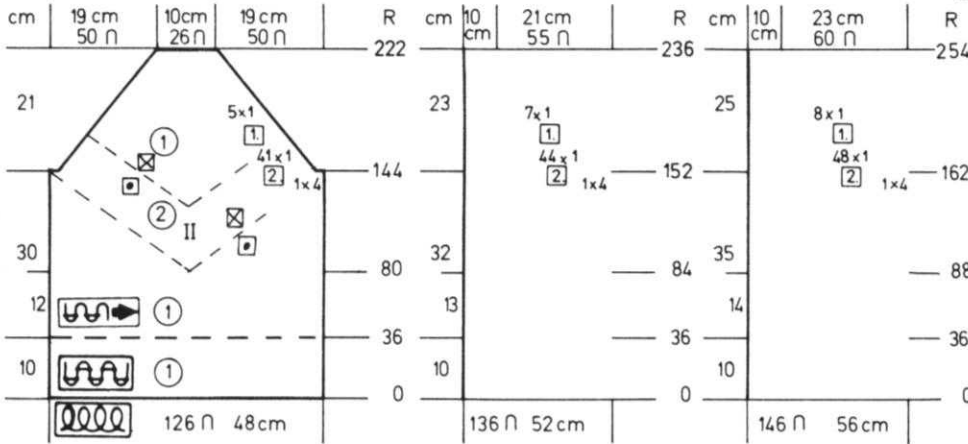

BACK: II

Cast on 126 (136) [146] sts. with color 1 and work 36 rows Ribbing. Continue in Stockinette stitch. After Row 80 (84) [88] Begin the SHORT ROWS (SEE IMPORTANT NOTE). After Row 144 (152) [162], SHAPE RAGLAN: ON EACH SIDE, bind off 4 sts. for all sizes, then ON EACH SIDE, decrease 1 st. every 2nd row 41x (44x) [48x] then ON EVERY ROW, decrease 1 st. 5x (7x) [8x]. After Row 222 (236) [254], bind off the remaining sts.

DK 931

WOMAN'S PULLOVER

SIZE: 10 to 14
 YARN: Pingouin Oued (Mohair)
 GRAMS:
 color 1 150
 color 2 100
 color 3 150
 color 4 50
 color 5 50
 TENSION: 7 to 9
 GAUGE: 12 sts. 15 rows = 5 cm (2")

Stockinette stitch using SHORT ROWS for the DESIGN. Bands are K2, P2 Ribbing.

FINISHING: See General Instructions.

IMPORTANT: BE SURE TO READ THE PRINTED INSTRUCTIONS.

MAKE SLEEVES FIRST: III

LEFT SLEEVE:

Cast on 80 sts. with color 1 and work in Ribbing to Row 24. Continue in Stockinette stitch AND ON EACH SIDE, increase 1 st. every 20th row 6x and CHANGE COLORS AS SHOWN ON THE CHART.

After Row 146, SHAPE ARMHOLE: ON EACH SIDE, bind off 2 sts. 6x. After Row 162, remove the sts. onto contrast waste yarn.

RIGHT SLEEVE:

Work the same as the left sleeve but change the colors as shown on the RIGHT SLEEVE CHART.

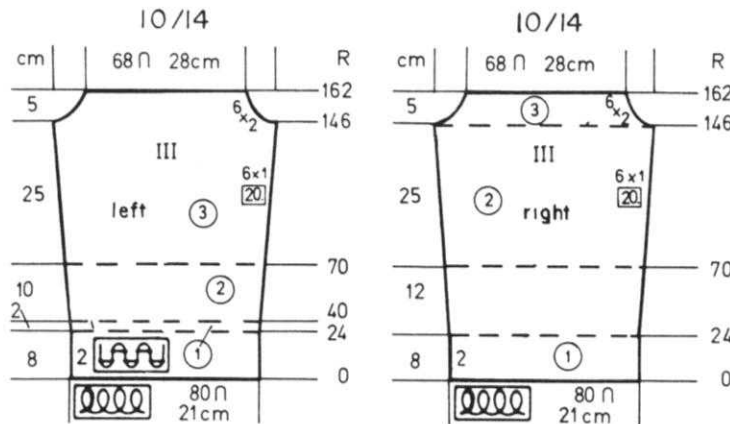

FRONT & BACK: 2 Sections the same.

Cast on 120 sts. with color 1 and work 24 rows Ribbing. Continue in Stockinette stitch changing the colors as shown on the Chart.
 After Row 134, put the center 26 sts. and all sts. to the left of these into holding position. Work SHORT ROWS over the remaining sts. AND AT THE SAME TIME SHAPE ARMHOLE same as the sleeve.
 FOR NECK, Put into holding position 5 sts. 7x.
 Put all these sts. into holding position. Bring 35 sts. on the left into working position, knit 1 row across, turn the Row Counter to 134 and work the SHORT ROWS same as on the right side. After Row 150, begin the Yoke.

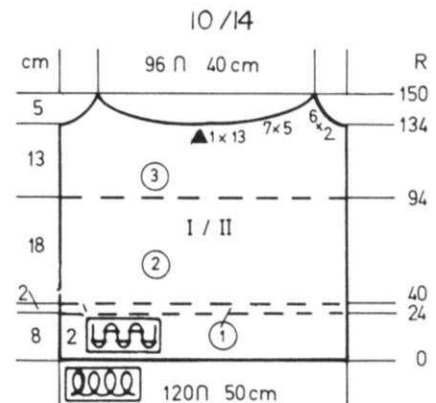

DK 931

YOKE:

ON EACH SIDE, hang HALF the sleeve sts. onto the machine (34 sts. for each sleeve. Work with color 3. Put all but 16 sts. on the right into holding position. Over the 16 sts. in work, make the point, using SHORT ROWS until 1 st. remains. Put all these sts. into holding position then bring the next 32 sts. into working position and work SHORT ROWS ON EACH SIDE until 2 sts.

remain. Put all these sts. into holding position. Continue in this way across the knitting until all the points are completed. (SEE CHART). Now go back and begin from the right side. Leave 16 sts. in holding 1 st. in knitting position and the rest in holding. Color 5. Bring back into working position 1 st. ON EACH SIDE until there are 10 sts. in work. Put these into holding position and work the next point. Work each point in the same way, following the Chart. When all is completed, remove the sts.

way, onto waste yarn. Hang the sts. back onto the machine, decreasing to 148 sts. following the Chart and color changes as given. After Row 57. Remove the sts. onto waste yarn. Hang the sts. back, decreasing to 128 sts. With color 4 continue to knit in Stockinette stitch. ON EACH SIDE, decrease 1 st. every 2nd row 4x. After Row 66, Decrease 11 sts. evenly across then work K1, P1 Ribbing for 10 rows. Bind off. Work other section of back (front) in the same way.

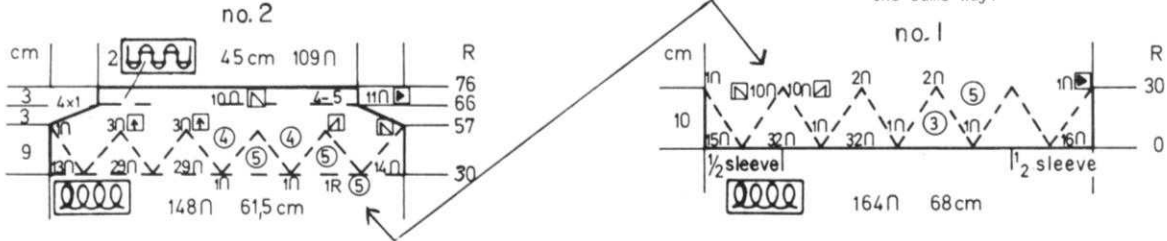

DK 932

WOMAN'S PULLOVER

SIZES: 10 (12) [14]
YARN: Pinquoin Oued (Mohair)
GRAMS:
 color 1 100 100 150
 color 2 50 50 100
 color 3 100 100 150
 color 4 100 100 150
TENSION: 8 to 10
GAUGE: 12 sts. 15 rows = 5 cm (2")

Stockinette stitch with color stripes using SHORT ROWS. Bands are K2, P2 Ribbing.

FINISHING: See General Instructions.

BACK & FRONT:

Cast on 110 (115) [120] sts. with color 1 and work 24 rows Ribbing. Continue in Stockinette stitch. After Row 40, BEGIN THE SHORT ROW STRIPES as shown on the Chart - working in Alphabetical order and changing the colors as shown. After Row 102 (102) [108] SHAPE SLEEVE on (a) section (and when you reach (e) section. INCREASE 1 st. every 4th row 2x, then every 2nd row 1 st. 4x, 2 sts. 4x, 3 sts. 1x, 4 sts. 1x, 8 sts. 1x.

After Row 178 (182) [186] SHAPE NECK in the proper sections following the Chart as given. After Row 200 (204) [208], Cast on the neck sts. in the proper sections as shown on the Chart. Continue to work the diagonal stripes as shown on the Chart SHAPING THE ARMHOLES in REVERSE after Row 268 (272) [278]. After Row 376 (384) [392], work Ribbing with color 1 to Row 400 (408) [416]. Bind off.

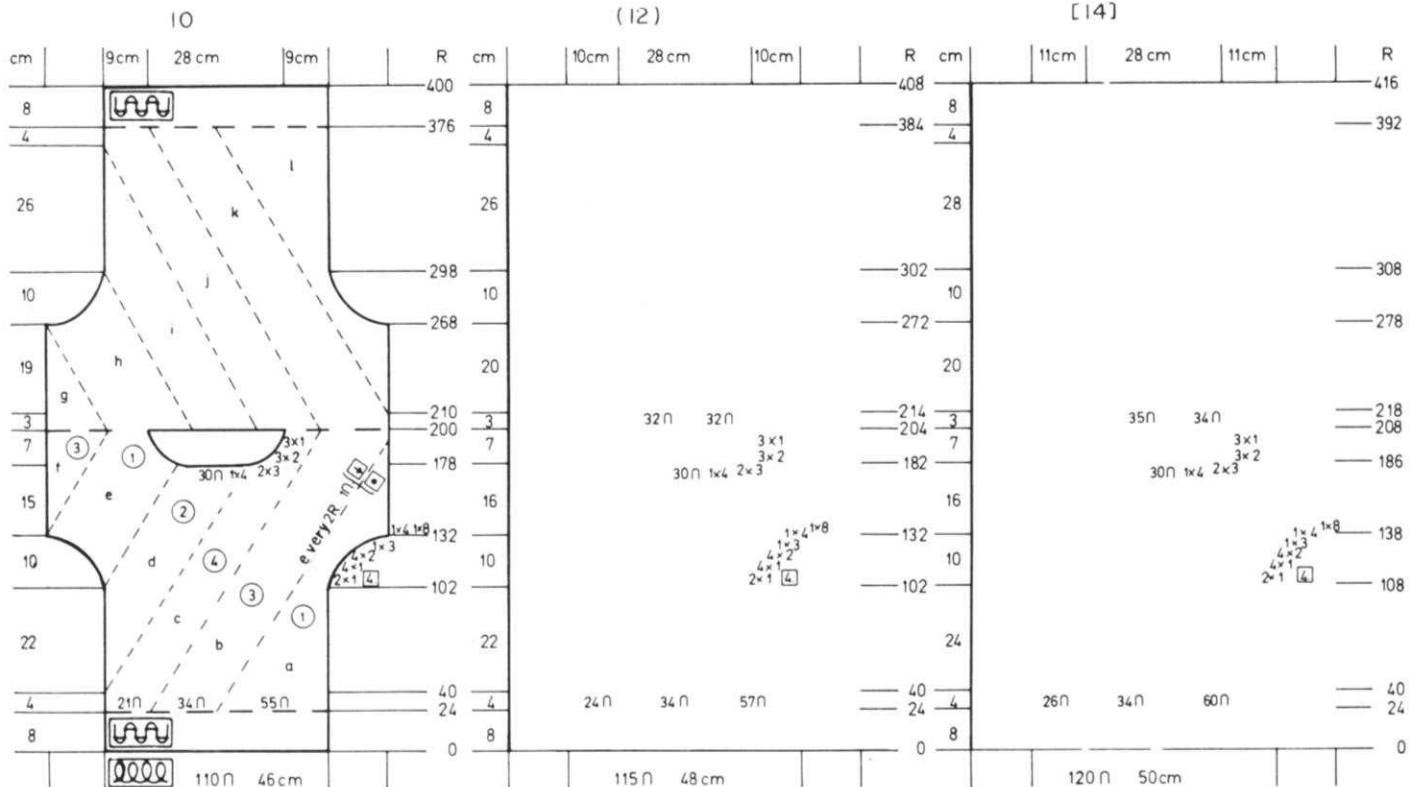

DK 934

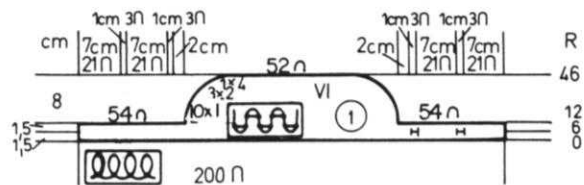

R COLLAR AND FRONT BAND:

Cast on 200 sts. and work in Ribbing. After Row 6, make **BUTTON-HOLES** on the right. Leave 21 sts. and make buttonhole over next 3 sts. Leave 21 and work buttonhole over the next 3 sts.

After Row 12, bind off 54 sts. **ON EACH SIDE.** SHAPE COLLAR after Row 18. **ON EACH SIDE,** bind off 1 st. 10x, 2 sts. 3x, 4 sts. 1x. After Row 46, bind off the remaining sts.

DK 935

WOMAN'S PULLOVER

SIZES: 7/8 (10/12)

YARN: Amore

GRAMS:
color 1 300 350
color 2 150 150
color 3 150 150

TENSION:
Stock. = 7 to 9
Nor. = 7 to 9
Slip = 9 or 10

GAUGE:
Stock: 11 sts. 17 rows = 5 cm (2")
Nor. & Slip: 11 sts. 13 rows = "

Stockinette stitch, a Norwegian Design plus Slip stitch and color stripes. Punch your own Card and follow the color changes and Pattern as shown along side the Punch Card. Bands are K1, P1 Ribbing.

FINISHING: See General Instructions.

BACK: II

Cast on 98 (104) sts. with color 1 and work 18 rows Ribbing. Continue in Stockinette stitch to Row 72. Continue in Pattern to Row 92, following the Punch Card with color changes. Continue in color stripes as shown on the Chart. After Row 126, **SHAPE ARMHOLE:** **ON EACH SIDE,** bind off for both sizes.

The first color given is ALWAYS in FEEDER "A" BEGIN HERE.

NORWEGIAN = 2 rows color 2 + 1

SLIP ST. = 1 row color 2
1 row color 3
1 row color 1
1 row color 2
1 row color 3
2 rows color 1
1 row color 3
2 rows color 1
1 row color 3
1 row color 2

NORWEGIAN = 7 rows color 2 + 1

SLIP ST. = 1 row color 2
1 row color 3
1 row color 1
1 row color 2
1 row color 3
2 rows color 1
1 row color 3
2 rows color 1
1 row color 3
1 row color 2

NORWEGIAN = 2 rows color 2 + 1

3 sts. 1x, 2 sts. 4x. Knit to Row 190 (194). **SHAPE SHOULDER AND WATCH FOR NECK SHAPING.** **FOR SHOULDER,** **ON EACH SIDE,** bind off 4 sts. 2x, 5 sts. 2x, (5 sts. 4x, 2 sts. 2x). After Row 194 (198), bind off the center 20 sts., put the needles on the left into holding position and complete the right side first. ***ON NECK SIDE,** bind off 6 (7) sts. 1x, 2 sts. 2x. Bring the needles on the left into working position, knit 1 row to the left side, turn the Row Counter back to 194 (198) and complete the left half. Follow the instructions from * and don't forget to complete the shoulder shaping.



7/8

(10/12)

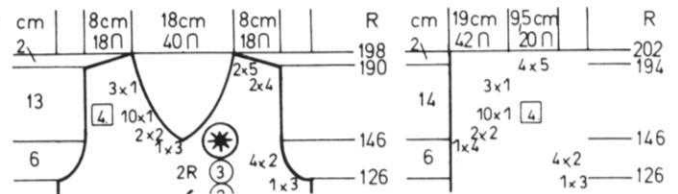

7/8

(10/12)

FRONT: I

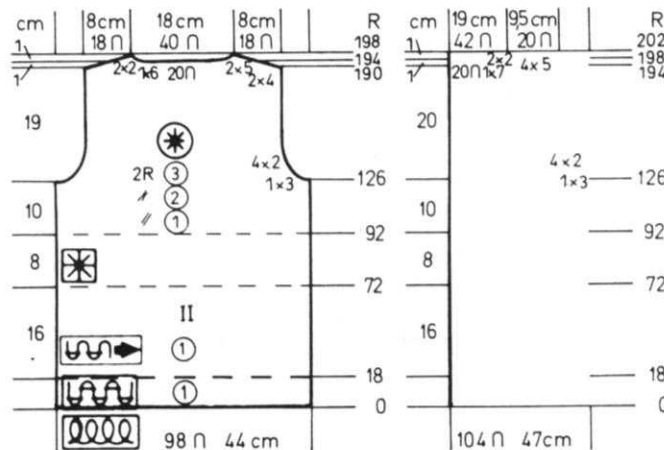

Work the front the same as the back to Row 126. **SHAPE ARMHOLE** same as the back then after Row 146, divide in the center. Put the needles on the left into holding position and complete the right side first. ***ON NECK SIDE,** bind off 3 (4) sts. 1x, then 2 sts. 2x, 1 st. every 4th row 10x, then 1 st. every 2nd row 3x. After Row 190 (194) **SHAPE SHOULDER** same as the back. Bring the needles on the left into working position, knit 1 row to the left side, turn the Row Counter back to 146 and complete the left half. Follow the instructions from *.

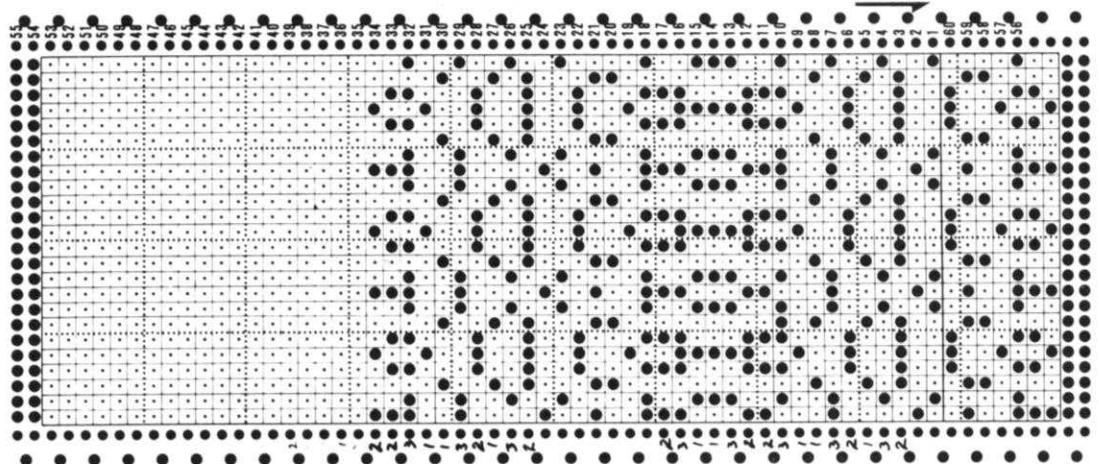

DK 935

SLEEVES: III

Cast on 52 sts. with color 1 and work 20 rows Ribbing. Continue in Stockinette stitch with color stripes. ON EACH SIDE, increase 1 st. every 10th row 13x. (every 10th row 5x, every 8th row 10x).

After Row 150, SHAPE CAP: ON EACH SIDE, bind off
2 sts. 4x, 3 sts. 2x, 1st. 8x,
3 sts. 1x, 2 sts. 2x, 6 sts. 1x.
(4 sts. 1x, 2 sts. 4x, 3 sts. 2x,
1 st. 8x, 3 sts. 2x, 2 sts. 2x,
5 sts. 1x.

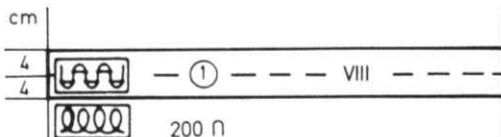

R NECKBAND: VIII

28 Cast on 200 sts. and work 28 rows Ribbing. Bind off 14 or remove onto contrast waste yarn.

7/8

(10/12)

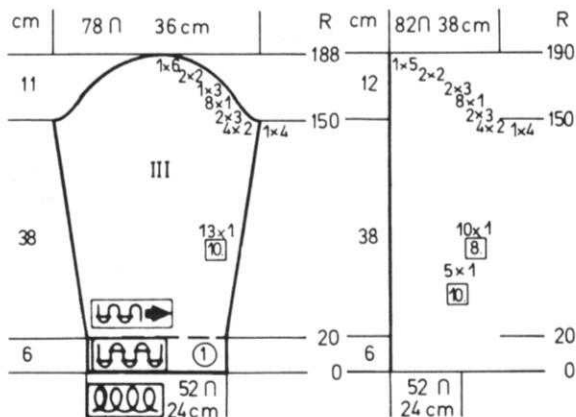

KK 936

CHILD'S PULLOVER

SIZES: 4 to 6
YARN: Euro Sport
GRAMS: color 1 250, color 2 50
TENSION: 8 to 10
GAUGE: 12 sts. 16 rows = 5 cm (2")

Stockinette stitch with a Norwegian Design. Bands are K1, P1 Ribbing.

FINISHING: See General Instructions.

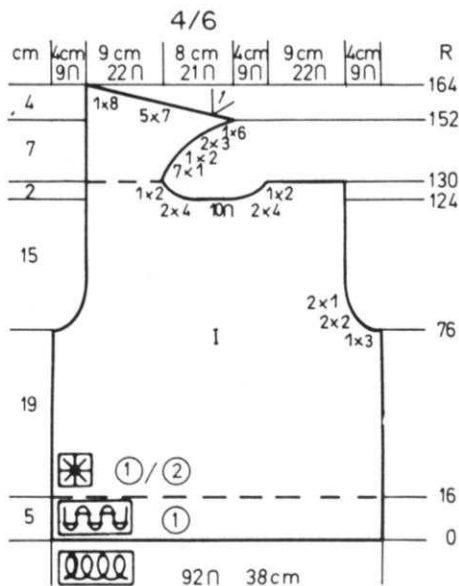

BACK: I

Cast on 92 sts. with color 1 and work 16 rows Ribbing. Continue in Norwegian Design working the Punch Card 1x only then continue in Stockinette stitch. After Row 76, SHAPE ARMHOLE: ON EACH SIDE, bind off 3 sts. 1x, 2 sts. 2x, 1 st. 2x. Knit to Row 124. Bind off the center 10 sts., put the needles on the left into holding position and complete the right side first. ON NECK SIDE, bind off 4 sts. 2x, 2 sts. 1x.

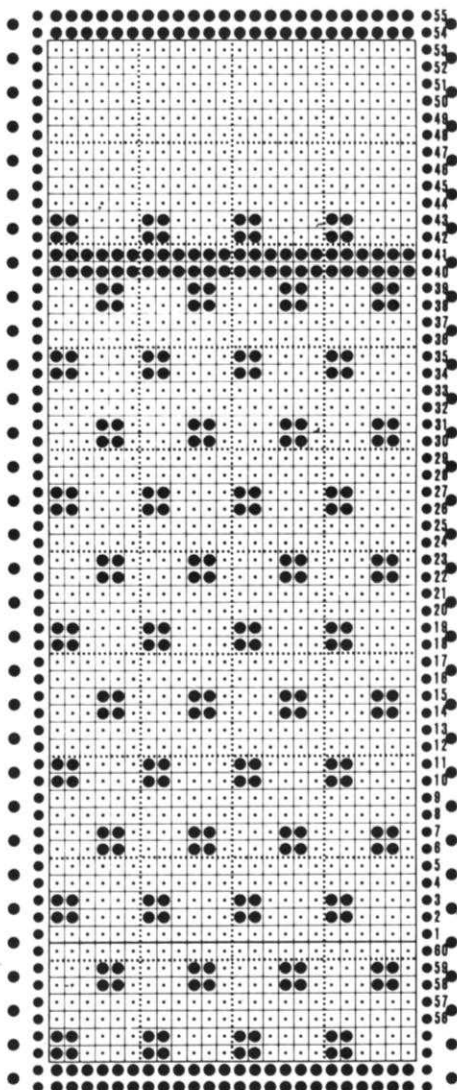

After Row 130, bind off the remaining sts. Bring the needles on the left into working position, knit 1 row to the left side, turn the Row Counter back to 124 and complete the left half. ON NECK SIDE, bind off 4 sts. 2x, 2 sts. 1x. After Row 129, ON NECK SIDE, increase 1 st. 7x, 2 sts. 1x, 3 sts. 2x, 6 sts. 1x. After Row 152, bind off 7 sts. 5x, 8 sts. 1x.

FRONT: II

Work the front the same as the back to Row 76. SHAPE ARMHOLE ON EACH SIDE, same as the back, and after Row 96, bind off 8 sts. 1x, 7 sts. 5x, and after Row 108, bind off 2 sts. 1x, 1 st. 7x. After Row 130, bind off the remaining sts.

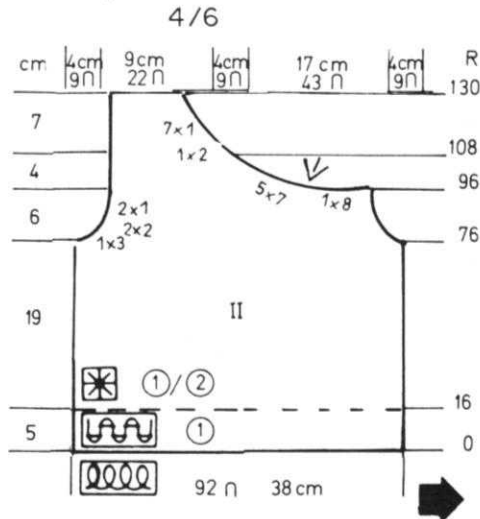

KK 936

NECKBAND: VIII

Cast on 112 sts. with color 2 and work in Ribbing. After Row 4, counting from the LEFT, make the first BUTTONHOLE over needles 4 and 5. Make the following buttonholes over 2 needles with 10 sts. between each one. A total of 5 buttonholes. After Row 10, bind off or remove onto contrast waste yarn.

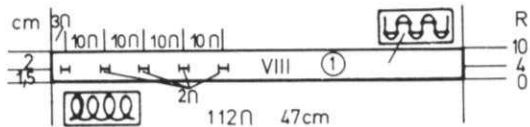

SLEEVES: III

Cast on 42 sts. with color 1 and work 16 rows Ribbing. Continue in Stockinette stitch. ON EACH SIDE, increase 1 st. every 8th row 7x, every 6th row 6x. After Row 108, SHAPE CAP: ON EACH SIDE, bind off 3 sts. 1x, 2 sts. 4x, 1 st. 10x, 2 sts. 5x, 3 sts. 1x.

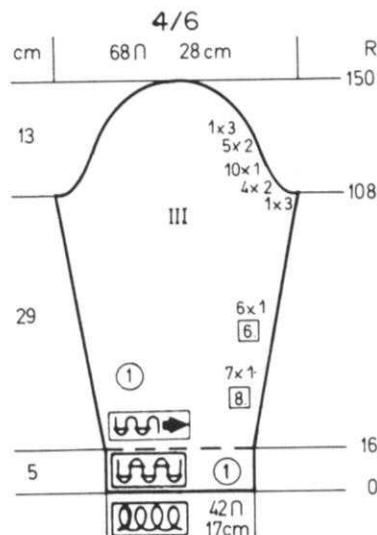

KK 937

CHILD'S CARDIGAN

SIZES: 6 to 8
YARN: Euro Sport
GRAMS:
color 1 300
color 2 50
color 3 100
TENSION: 8 to 10
GAUGE: 12 sts. 16 rows = 5 cm (2")

A Norwegian Design. Punch your own Card and follow the color changes given along side the Card. Bands are K1, P1 Ribbing.

FINISHING: See General Instructions.

BACK: II

Cast on 96 sts. with color 1 and work 12 rows Ribbing. Continue in the Norwegian Design. After Row 82, SHAPE ARMHOLE: ON EACH SIDE, bind off 3 sts. 1x, 2 sts. 4x, 1 st. 2x. After Row 136, bind off the center 14 sts., put the needles on the left into holding position and complete the right side first. *ON NECK SIDE, bind off 3 sts. 2x. Bring the needles on the left into working position, knit 1 row to the left side, turn the Row Counter back to 136 and complete the left half. Follow the instructions from *.

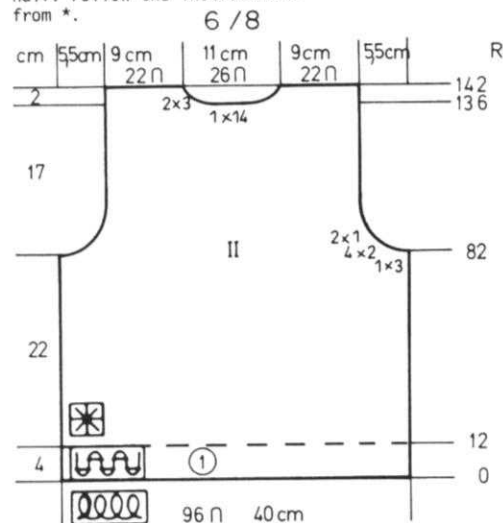

POCKET: Make 2.

Cast on 25 sts. with waste yarn and work in Ribbing. Knit 10 rows, then change to color 1 and put Counter at 0. Knit to Row 20. Work 2 rows color 3, 2 rows color 2. After Row 24, bind off.

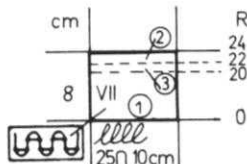

THE SLEEVES ARE A REPEAT FROM * TO * ONLY.

BEGIN HERE...

- * 2 rows color 1
- 2 rows color 1 + 2
- 2 rows color 1
- 2 rows color 1 + 2
- 2 rows color 1
- 2 rows color 1 + 2
- 2 rows color 1
- * 2 rows color 1 + 2
- 2 rows color 1
- 2 rows color 3
- 2 rows color 2
- 2 rows color 1
- 2 rows color 1 + 3
- 2 rows color 1
- 2 rows color 1 + 3
- 2 rows color 1
- 2 rows color 1 + 3
- 2 rows color 1
- 2 rows color 1 + 3
- 2 rows color 1
- 2 rows color 2
- 2 rows color 3

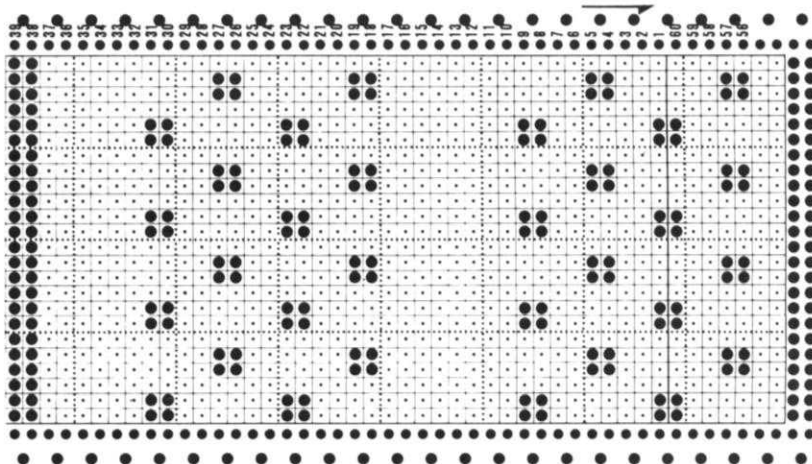

FRONT: I (Make Pockets first). Make 1, reverse 1.

Cast on 44 sts. with color 1 and work 12 rows Ribbing. Transfer the ribber sts. to main machine. Leave 10 sts. on the left (right) and 9 on the right. Remove the 25 sts onto a stitch holder then hang the open pocket sts. with right side facing you onto the empty needles and hang the sts. from the stitch holder onto the same needles. Continue in Pattern. After Row 82, SHAPE ARMHOLE same as the back, then knit to Row 119. SHAPE NECK: Bind off 3 sts. 1x, 2 sts. 2x, 1 st. 2x. After Row 142, bind off the remaining sts.

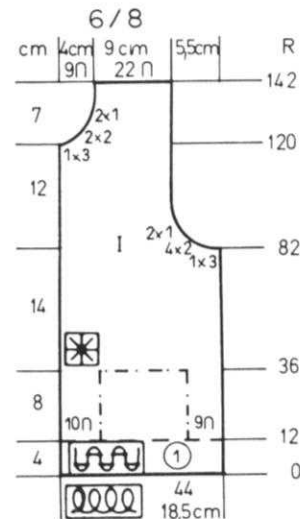

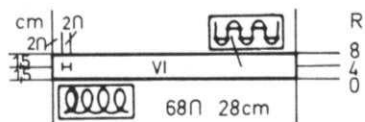

FRONT BANDS: Make 1 with and 1 without BUTTONHOLES.

Cast on 92 sts. with color 1 and work in Ribbing.
After Row 4, make BUTTONHOLES. Leave 6 sts. on the left and work buttonhole over the next 2 sts. Leave 16 sts. between and work buttonhole over the following 2 sts. etc. etc. for a total of 5 buttonholes. After Row 8, bind off or remove onto waste yarn.

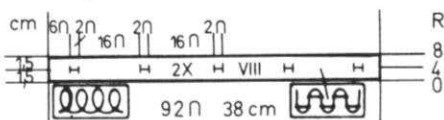

NECKBAND: VI

Cast on 68 sts. with color 1 and work in Ribbing.
After Row 4, on the left, leave 2 sts. and make one buttonhole over the next 2 sts.
After Row 8, bind off or remove onto contrast waste yarn.

SLEEVES: III

Cast on 44 sts. with color 1 and work 12 rows Ribbing.
Continue in Pattern.
ON EACH SIDE, increase 1 st. every 8th row 3x, every 6th row 1x.
After Row 108, SHAPE CAP:
ON EACH SIDE, bind off 4 sts. 1x, 2 sts. 4x, 1 st. 13x, 3 sts. 1x, 2 sts. 2x, 4 sts. 1x.

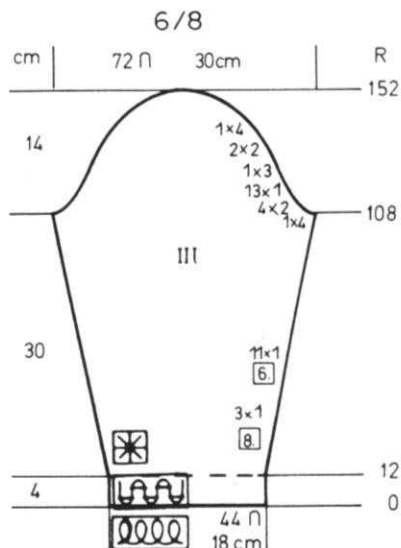

Lace Collar & Cuffs

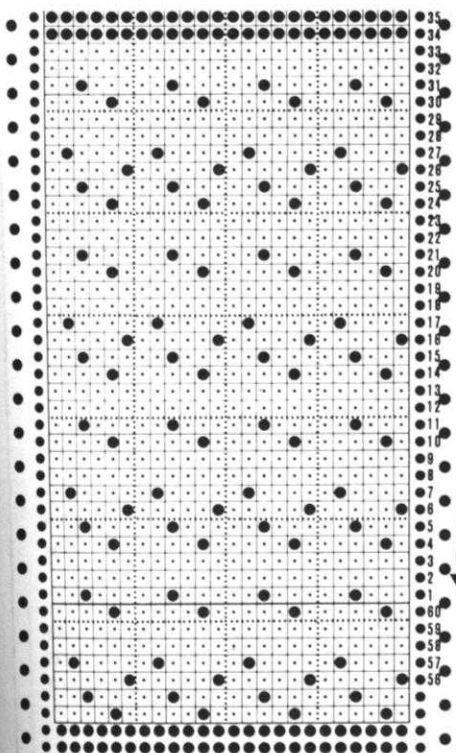

YARN: Vienna
GRAMS: 50
TENSION: 5 or 6
GAUGE: 15 sts. 23 rows = 5 cm
measured over pattern st.

A Lace Pattern with changes in Tensions and Stockinette stitch.
Punch Card.
FINISHING: Press carefully then remove the waste yarn. Hide ends. Fold on the large tension row and press. Sew to dress or blouse with folded edge to inside, or you can sew small button on the left edge, make crochet loop for buttonhole. Tack on the underside to dress or blouse.

BEGIN ALL SECTIONS WITH CONTRAST WASTE YARN AND RAVEL CORD.
WORK "e" (permanent) cast on over the Ravel Cord.

COLLAR: Make 2 sections.

Bring needle 48 on the left and needle 45 on the right into working position., then all needles in between. 93 sts. Cast on over the 93 sts. with waste yarn. After knitting 9 to 11 rows, work 1 row Ravel Cord, then 'e' cast on. Knit 2 rows and begin lace Pattern with Tension 5.



Knit to Row 10.
Change Tension to 4.2, knit to Row 18.
Change to Tension 3 and Stockinette stitch.
Knit to Row 28.
Knit 1 row Tension 6 or 7. Turn Tension back to 3 and knit to Row 38. Bind off the crochet method - loosely.

CUFFS: Make 2.

Use the same method for casting on as you did for the Collar.
Cast on 66 sts. and with tension 4, knit in Pattern same as Collar to Row 14.
Change to Stockinette stitch and tension 3. Knit to Row 20.
Work 1 row Tension 6 or 7.
Change tension back to 3 and knit to Row 30. Bind off the crochet method - loosely.

Slippers

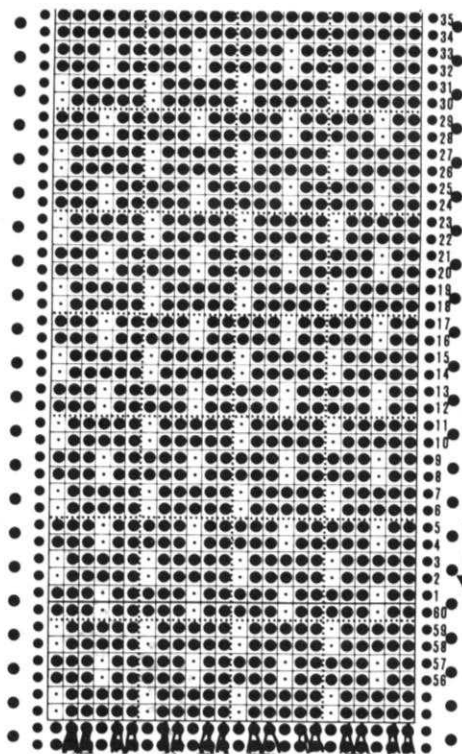

SIZES: Small Medium Large
 YARN: Euro Sport
 GRAMS: 100 100 100
 TENSION: 9 or 10 over EVERY 3rd NEEDLE
 GAUGE: 8 sts. 22 rows = 5 cm (2")

A Tuck Stitch Pattern using every 3rd needle. Punch your own Card and push in BOTH TUCK Buttons. Worn on purl side.

FINISHING: Sew up front to end of decreases. Pull up the cast on edge firmly then sew up back seam (Remove waste yarn first). Work 1 row single crochet around top edge, going into every other stitch on edge, then work 1 row reverse single crochet. Trim front with pom-poms or flowers. You can use contrast color for the crochet and trim if you wish.

NOTE: WAX YARN for easier knitting in Pattern. Use plenty of weights so the doubled stitches will knit off.

Cast on 25 (27) [27] sts. in the following way. Bring the first needle to the right of 0 into working position then bring every 3rd needle into work on each side. You will end with needle 36 on the left, 38 on the right for small size - needle 39 on the left and needle 40 on the right for medium and large sizes.

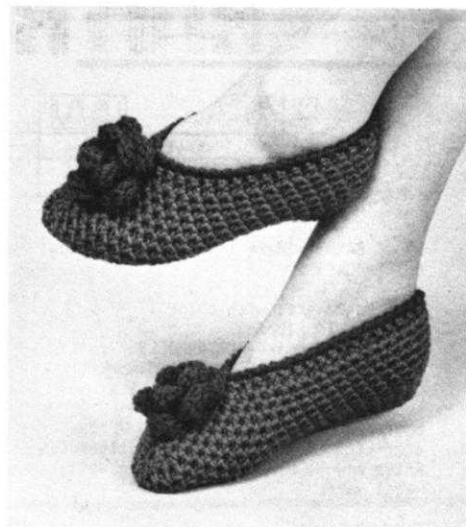

Cast on with contrast waste yarn and after knitting 8 to 10 rows 'e' cast on over the waste yarn (closed cast on). Hang plenty of weights. Counter at 0. Knit 1 row to the left side, Set Card on Stop, push in KC and knit 1 row to the right side. Push in BOTH TUCK BUTTONS and knit in Pattern to Row 70 (78) [88]. ON EACH SIDE, decrease 1 st. every 2nd row until 11 (13) [13] stitches remain. Knit 1 row over all needles then remove the sts. onto end of yarn. Pull up and tie tightly.

KNITTING MACHINE WORKBOOKS

By Tami Nobuyuki

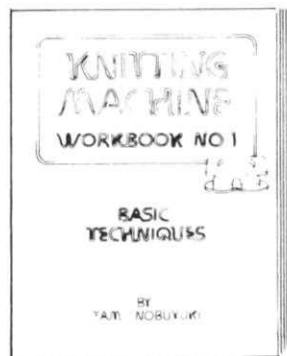

BOOK 1. BASIC TECHNIQUES is a complete instruction course for all makes of single bed machines - including tips and techniques - all clearly illustrated - enabling the reader to become fully skilled and knowledgeable on her own machine.

BOOK 2. BASIC RIBBER TECHNIQUES is a comprehensive instruction guide for all makes of ribbing attachments - packed full of tips and illustrations showing how to get the most from your ribber.

BOOK 3. PATTERN KNITTING TECHNIQUES which includes instructions for patterning on push button & manual machines as well as automatic punchcard machine - designing and punching your own pattern cards including lace and ideas for creative knitting.

PRICES

Workbook 1	\$13.95
Workbook 2	\$15.95
Workbook 3	\$16.95

Available from your local dealer or send to KNITKING: 1128 Crenshaw Blvd., Los Angeles, Calif. 90019.

I enclose payment for _____ Shipping costs \$1.25 ea.
 Workbook 1 — 2 — 3 — (Canada) \$2.75 ea.
 Calif. residents add Sales Tax.

Name

Address

ZIP



KNITTING NEWS

PRACTICAL KNITTING HINTS

ADD A STITCH FOR SEAMING

When you need to work a front or back of a garment in sections (for a specific Design such as in DK 915 in this issue), it will be easier for you to put the parts together if you will add 1 stitch for seaming when you knit each section.

DK 915 in this issue is an example where you need to add the extra stitches as follows:
After Row 190 (200), put all but 23 sts. on the right into holding position. You need an extra stitch on the left of the 23 sts. in working position - so, remove 2 or 3 of the holding stitches directly next to the 23 sts. in work and put them on a pin or strand of yarn (to be picked up later) Although you only need 1 empty needle to add the extra stitch, it makes knitting easier for you when you remove the 2 or 3 sts. Add the extra stitch and you now have 24 sts. Continue knitting this section and follow the instructions as given. When you have completed the armhole shaping, knit to row 506 (520) then bind off.

Put the Row Counter to 190, bring all the needles into working position and hang the 2 or 3 sts. held on the pin back onto the machine, then add 1 extra stitch for seaming. Knit to Row 290 (300) then put 23 sts. on the left into holding position Remove 2 or 3 sts. onto a pin from the holding needles on the right, add 1 extra stitch for seaming to the left side of the 42 needles in work and continue to knit this section.

When you have completed this section, bring the remaining needles into working position, hang the 2 or 3 sts. held on pin back onto the machine, add 1 extra stitch and complete this section as given in the instructions.

When you are ready to put your garment together, you will find that seaming 1 stitch in on all parts will give you the perfect professional finish.

CANADIANS PLEASE NOTE

KNITTING has appointed NAN LYNCH Distributing of 2180 Yonge Street (Box 43) TORONTO, ONTARIO, CANADA M4S 2B9 as exclusive distributors for CANADA.

Please contact NAN LYNCH direct for all of your knitting machine needs. The phone number is 416 487 5914.

BONUS PUNCH CARDS

Here are 2 Fair Isle (Norwegian) designs for you to punch and knit something special. Use the airplane card for knitting son's or grandson's pull-over (be sure to change color for the clouds), then knit something for yourself with the other lovely card.

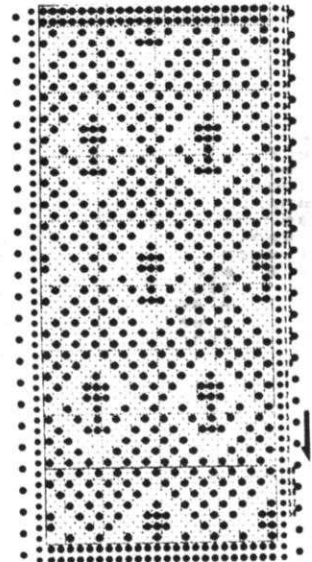
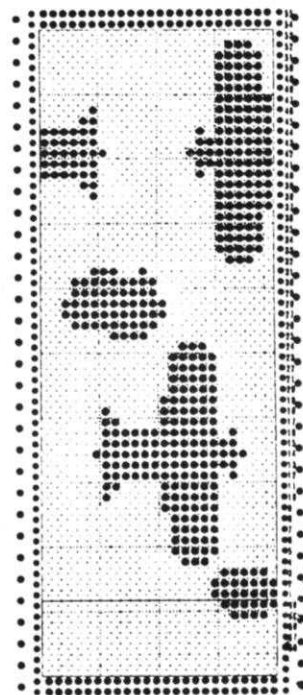

KNITTING BINDERS — Holds One Complete Year's Copies

Keep all your KnitKing Magazines together and build a beautiful library of patterns

\$5.95 ea. Available from KNITTING: 1128 Crenshaw Blvd.
Los Angeles, Calif. 90019

I enclose \$ for Binders (Calif. residents
add Sales Tax) plus \$1.25 Shipping costs.(Canada \$2.75)

Name

Address

ZIP

DISCOUNTED YARN KITS FOR THIS ISSUE

The Yarn Kits for this issue of KNITTING MAGAZINE are available at special discounts to our subscribers and the prices are only good until the next issue of the magazine. Be sure to check the colors available listed at the end of this NEWSLETTER and make certain to give alternate colors.

KK 910 - Yarn: Amore
 SIZES: 2 to 4
 Regular Price \$16.73
 Sale Price 14.18
 Shipping costs 1.85

DK 911 - Yarn: Knitting Worsted 4-ply plus a Novelty Yarn and thin Yarn for hanging Yoke.

NO KIT AVAILABLE.

DK 912 - Yarn: Pingouin Oued
 SIZES: 8/10 (12/14)
 Regular Price \$29.50 \$29.50
 Sale Price 23.60 23.60
 Shipping costs 1.85 1.85

KK 913 - Yarn: Pingouin Oued
 SIZES: 4 (6) [8]
 Regular Price \$29.50 \$29.50 \$32.45
 Sale Price 23.60 23.60 25.95
 Shipping costs 1.85 1.85 1.85

DK 914 - Yarn: Pingouin Pescadou
 SIZES: 8/10 (12/14)
 Regular Price \$94.50 \$105.00
 Sale Price 75.60 84.00
 Shipping costs 1.85 1.85

DK 915 - Yarn: Pingouin Pescadou
 SIZES: 7/8 (10/12)
 Regular Price \$45.50 \$56.00
 Sale Price 36.40 44.80
 Shipping costs 1.85 1.85

DK 916 - Yarn: Pingouin Pescadou
 SIZES: 10 (12)
 Regular Price \$38.50 \$38.50
 Sale Price 30.80 30.80
 Shipping costs 1.85 1.85

DK 917 - Yarn: Vienna
 SIZES: 5/6 (8/10)
 Regular Price \$27.35 \$30.05
 Sale Price 21.88 24.04
 Shipping costs 1.85 1.85

DK 918 - Yarn: Pingouin Oued
 SIZES: 7/8 (10/12) [14/16] /18/20/
 Regular Price \$17.70 \$20.65
 Sale Price 14.16 16.52
 Shipping costs 1.85 1.85

DK 919 - Yarn: Pingouin Oued
 SIZES: 7/8 (10/12) [14/16] /18/20/
 Regular Price \$32.45 \$38.35
 Sale Price 25.96 30.68
 Shipping costs 1.85 1.85

DK 920 - Yarn: Amore
 SIZES: 8/10 (12/14)
 Regular Price \$28.68 \$31.07
 Sale Price 22.94 24.86
 Shipping costs 1.85 1.85

HP 921 - Yarn: Amore
 SIZES: 38 (40.42)
 Regular Price: \$43.02 \$45.41
 Sale Price 34.42 36.33
 Shipping costs 1.85 1.85

KK 922 - Yarn: Fortissima
 SIZES: 4/6 (8) [10/12]
 Regular Price \$12.90 \$18.06 \$23.22
 Sale Price 10.32 14.45 18.58
 Shipping costs 1.85 1.85 1.85

DK 923 - Yarn: Amore
 SIZES: 8 (10) [12]
 Regular Price \$33.46 \$35.85 \$35.85
 Sale Price 26.77 28.68 28.68
 Shipping costs 1.85 1.85 1.85

DK 924 - Yarn: Amore
 SIZES: 5/6 (7/8) [10/12]
 Regular Price \$28.68 \$28.68 \$31.07
 Sale Price 22.94 22.94 24.86
 Shipping costs 1.85 1.85 1.85

DK 925 - Yarn: Amore
 SIZES: 7/8 (10/12) [14/16]
 Regular Price \$47.80 \$50.19 \$54.97
 Sale Price 38.24 40.15 43.98
 Shipping costs 1.85 1.85 1.85

HP 926 - Yarn: Pingouin Type Shetland
 SIZES: 34/36 (38/40) [42/44]
 Regular Price \$38.50 \$41.25 \$44.00
 Sale Price 30.80 33.00 35.20
 Shipping costs 1.85 1.85 1.85

DK 931 - Yarn: Pingouin Oued
 SIZES: 10 to 14
 Regular Price \$29.50
 Sale Price 23.60
 Shipping costs 1.85

DK 932 - Yarn: Pingouin Oued
 SIZES: 10 (12) [14]
 Regular Price \$20.65 \$20.65 \$32.45
 Sale Price 16.52 16.52 25.96
 Shipping costs 1.85 1.85 1.85

DK 933 - Yarn: Amore
 SIZES: 8/10 (12/14)
 Regular Price \$21.51 \$23.90
 Sale Price 17.21 19.12
 Shipping costs 1.85 1.85

DK 934 - Yarn: Amore
 SIZES: 12 (14)
 Regular Price \$23.90 \$28.68
 Sale Price 19.12 22.94
 Shipping costs 1.85 1.85

DK 935 - Yarn: Amore
 SIZES: 7/8 (10/12)
 Regular Price \$28.68 \$31.07
 Sale Price 22.94 24.86
 Shipping costs 1.85 1.85

KK 936 - Yarn: Euro Sport
 SIZES: 4 to 6
 Regular Price \$10.50
 Sale Price 8.40
 Shipping costs 1.85

KK 937 - Yarn: Euro Sport
 SIZES: 6 to 8
 Regular Price \$15.75
 Sale Price 12.60
 Shipping costs 1.85

CHOOSE YOUR YARN KITS FROM THE FOLLOWING COLORS

AMORE: White, Dark Green, Pink, Rust, Red, Coral
 Yellow, Rsoe, Beige, Med. Blue, Navy,
 Turquoise, Jade Green, Plum, Lilac, Dk.Grey,
 Med.Grey, Orange Tweed, Beige Tweed, Ivory,
 Brown, Wine Red.

FORTISSIMA: . . White, Black, Tan, Dk.Green, Beige Tweed,
 Green Tweed, Blue Tweed, Turquoise

MICAELA: . . . White, Black, Turquoise, Tan Brown, Orange,
 Peach, Sea Green, Grass Green, Yellow

VIENNA: . . . White, Black, Lt.Green, Lilan, Peach, Coral,
 Yellow, Brown, Moss, Beige, Med. Blue, Red,
 Plum, Gold, Aqua, Peacock Blue

EURO SPORT: . . Black, White, Green Moss, Green Tweed,
 Yellow, Marine Blue

PINGOUIN YARNS . . Your choice of colors as shown in pictures
 of KNITTING MAGAZINE this issue.

...it's new from Knitking
The KH-120/258
fine needle
knitter

Especially for
fine yarn...
(from crochet thread to
to sport yarn)

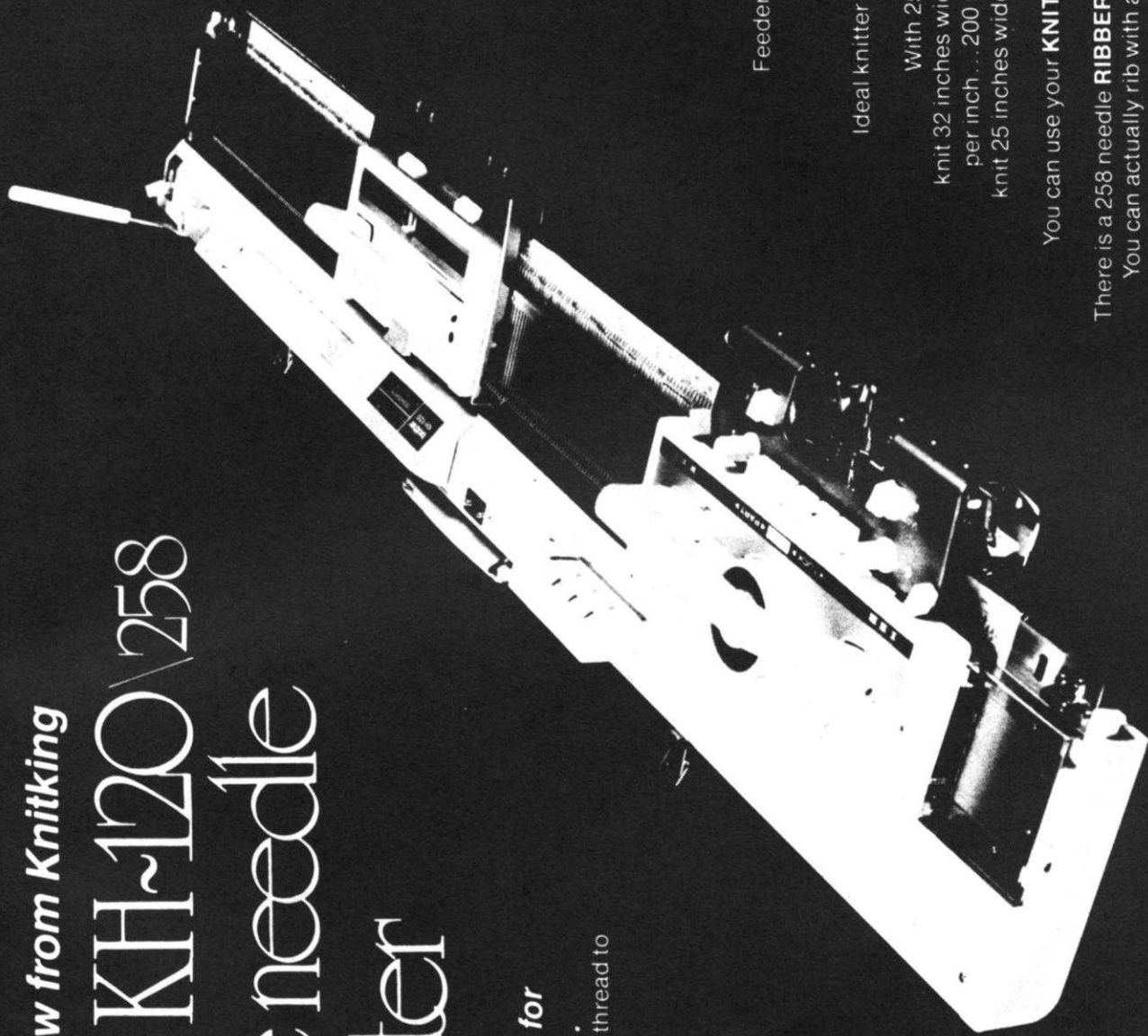

With the new
LACEMAKER that makes
exquisite fine lace as
well as
standard lace.

The **KH-120** has Twin Yarn
Feeders and Push Button Pattern
Selection for an unlimited
number of fancy stitches.

Ideal knitter for large people.

With 258 needles, the **KH-120** will
knit 32 inches wide when knitting 8 stitches
per inch... 200 needle machines can only
knit 25 inches wide at the same stitch gauge.

You can use your **KNITLEADER** with the **KH-120**.

There is a 258 needle **RIBBER ATTACHMENT** available.
You can actually rib with a fine yarn over as many as
516 needles for a superfine rib knit. You can also knit
tubular using 516 needles.

JUMBO *winds an eight oz. ball* YARN WINDER



NEW AND
REVOLUTIONARY DESIGN

Winds yarn without
twisting it. The Cone
lifts off and stands
behind your machine... or
you can remove the ball and
pull yarn from its center.

price

\$19.95

Calif. residents add Sales Tax
Order from your dealer or direct from KNITKING

A woman with her hair in a bun, smiling, wearing a light purple ribbed knit sweater and matching wide-leg pants. She is holding a red ball in her right hand. The entire scene is set against a black background and enclosed in a white decorative border with floral motifs at the corners.

DK920



DK 911

DK 932

DK 931



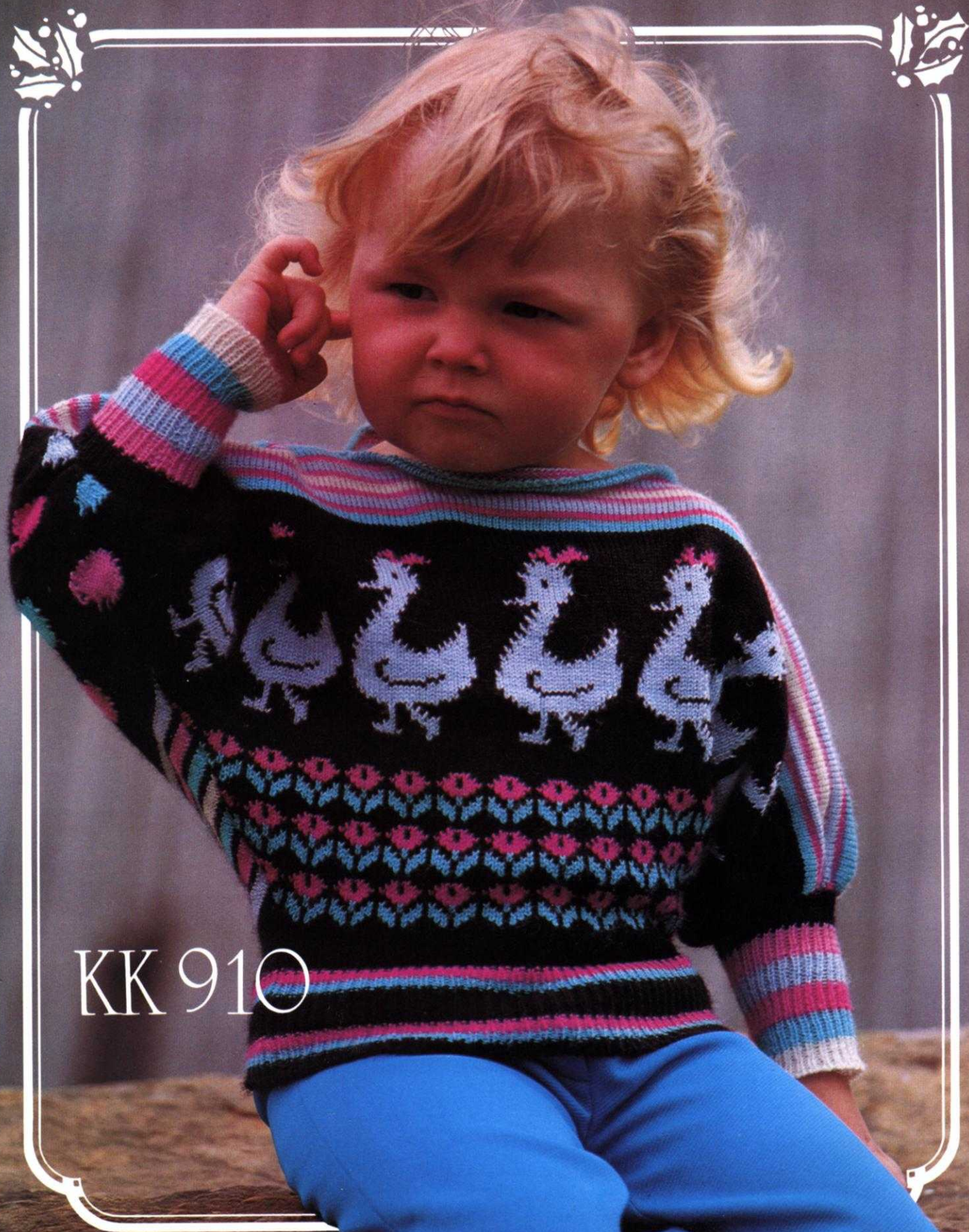

KK 910



DK 925

A man with light brown hair is sitting on a stack of wooden planks. He is wearing a grey and white striped sweater with a white chevron pattern on the chest and white trousers. The sweater has a ribbed crew neck, cuffs, and hem. The background is a warm, golden-brown wooden wall. The entire image is framed by a white decorative border with floral motifs at the corners.

HP926



KK922

HP921



KK 913



KK 937

KK 936

A woman with short brown hair is smiling and sitting on a pile of grey rocks. She is wearing a vibrant turtleneck sweater with a complex geometric pattern in shades of blue, green, and black, accented with thin red lines. Her pants are a solid, bright red. The entire scene is framed by a decorative white border with ornate corner pieces.

DK933