

# knitking

*magazine*





DK970

X 1/2-81



DK974

A woman with blonde hair is smiling broadly, wearing a purple and green patterned sweater with a white lace collar and a frog applique. The sweater features a repeating pattern of green fish-like shapes on a purple background. The frog applique is green with blue eyes and is positioned at the bottom center of the sweater. The woman is also wearing white pants. The background is dark with a white border and decorative corner elements.

DK969

DK977



DK972

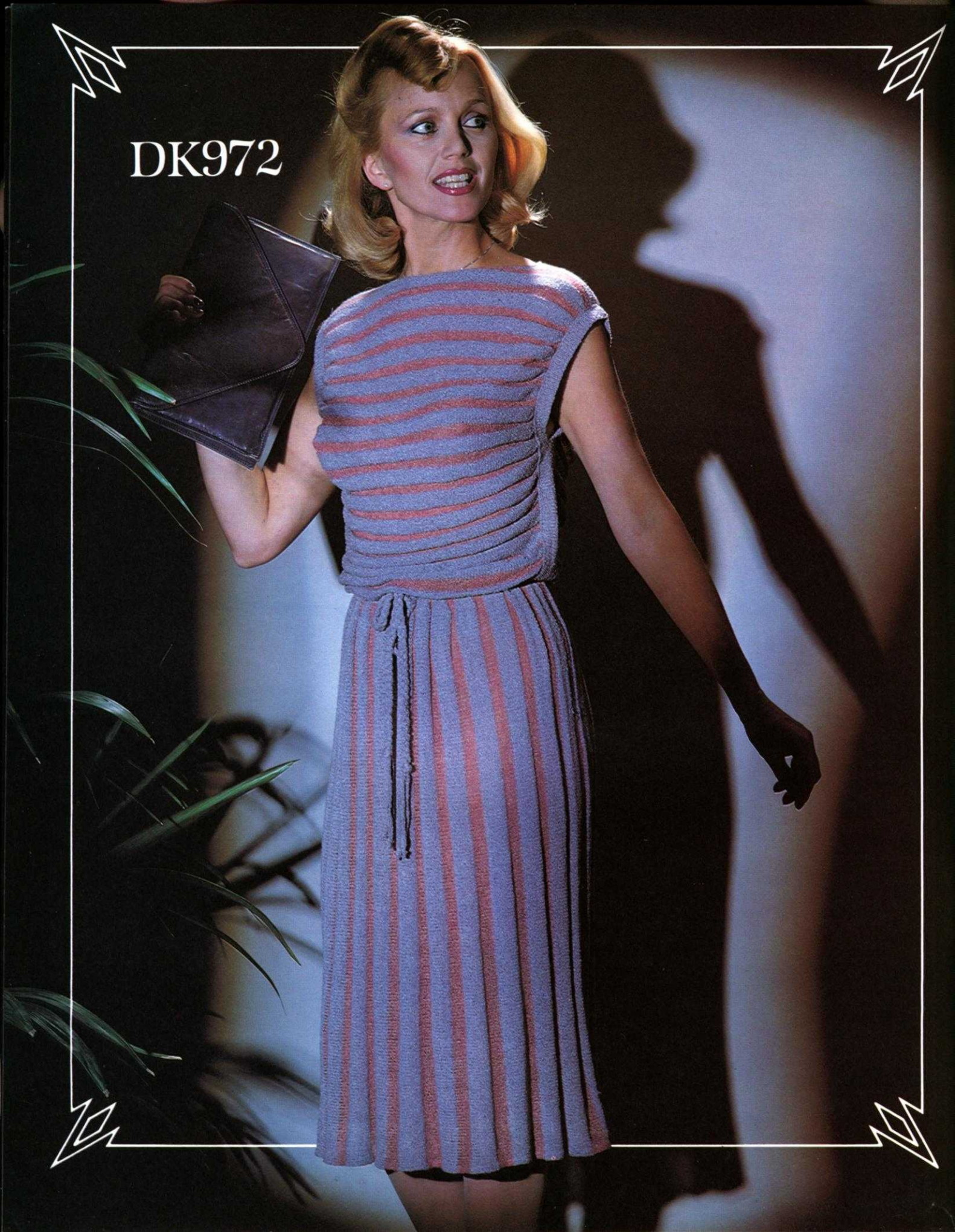

DK973



DK976

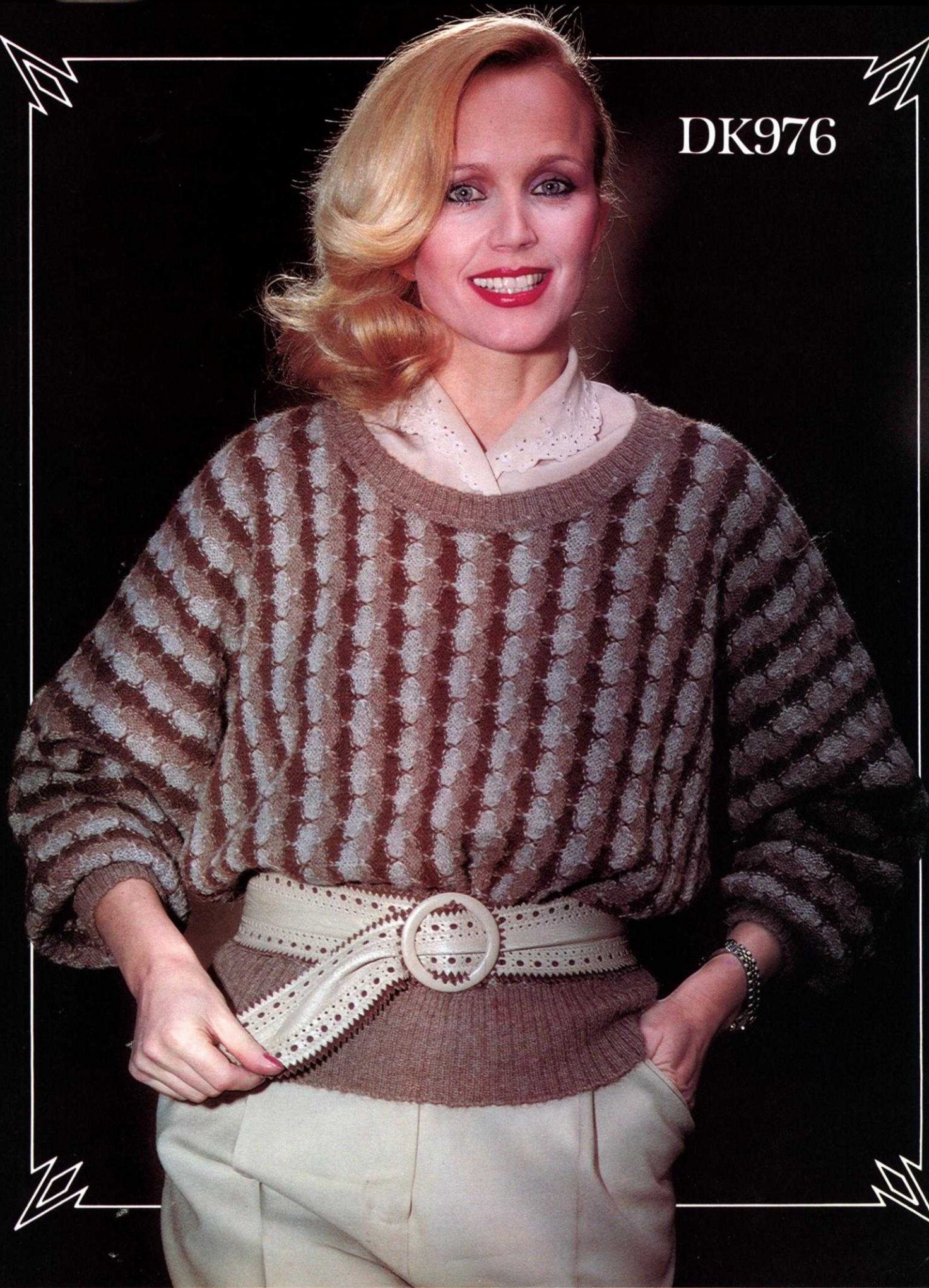





DK975

DK978

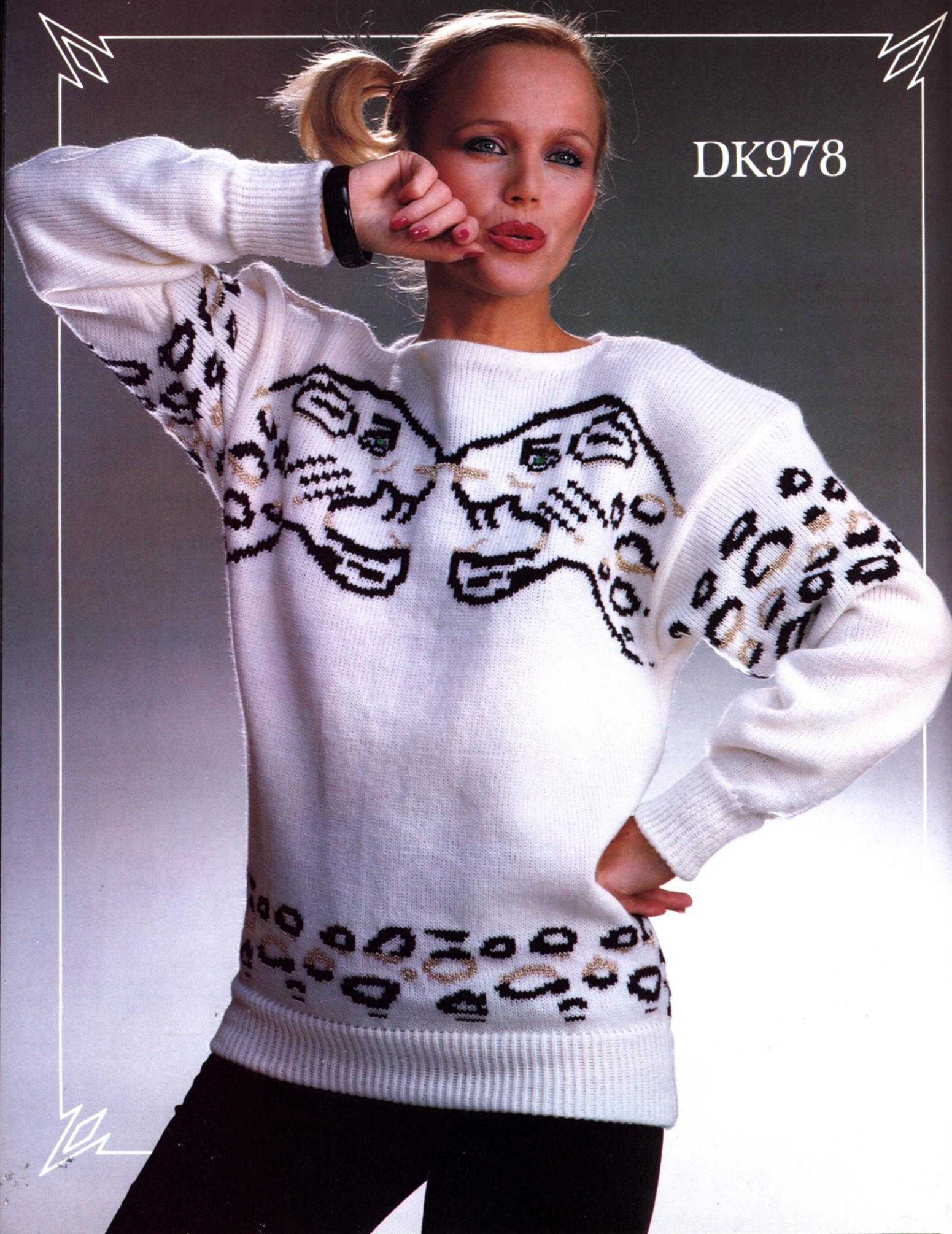

# knitking

magazine

TABLE OF CONTENTS	PAGE NO.
KK 959 - Girl's Jumper & Knee Socks . . . . .	14
KK 960 - Girl's Skirt & Jacket Vest . . . . .	15
KK 961 - Child's Pullover & Socks . . . . .	16
HP 962 - Man's Pullover . . . . .	18
DK 963 - Woman's Pullover . . . . .	19
HP 964 - Man's Pullover . . . . .	21
DK 965 - Woman's Cardigan . . . . .	22
DK 966 - Woman's Sleeveless Pullover . . . . .	23
DK 967 - Woman's Pullover . . . . .	24
DK 968 - Woman's Pullover . . . . .	25
DK 969 - Woman's Pullover . . . . .	25
DK 970 - Woman's Dress . . . . .	26
DK 971 - Woman's Two Piece Dress . . . . .	27
DK 972 - Woman's Dress . . . . .	28
DK 973 - Woman's Dress . . . . .	29
DK 974 - Woman's Dress . . . . .	30
DK 975 - Woman's Bedjacket . . . . .	30
DK 976 - Woman's Pullover . . . . .	31
DK 977 - Woman's Jacket & Skirt . . . . .	32
DK 978 - Woman's Pullover . . . . .	34
DK 979 - Woman's Pullover . . . . .	35
DK 980 - Woman's Pullover . . . . .	35
HP 981 - Man's Pullover . . . . .	36
HP 982 - Man's Vest . . . . .	37
DK 983 - Woman's Jacket . . . . .	38

## editorial

A visitor to our Seminar last year said, and we quote: "I have always insisted that if you have seen one knitting machine Seminar, you have seen them all, but my visit to your Seminar has certainly changed my opinion... Your Seminar is truly different and much more educational..."

The statement is not an isolated one... similar comments have been made by many of our visitors... We do endeavour to make our Seminars more interesting, more exciting and more educational than run of the mill knitting machine Seminars. KNITKING Seminars are also famous for the wonderful display of stylish garments, many from KNITKING MAGAZINE. In addition to the permanent display, every member of our staff wears something new every Seminar day, the yarns and Patterns for which are available at substantially discounted prices.

















In addition to the team of experts that work at KNITKING, producing this magazine, designing garments for it, teaching in our School, running our Yarn Department etc., we bring in experts and personalities from outside. Internationally famous Designers like Carlos Arias... authorities and authors like Tami Nobuyuki, professional Pattern Makers like Rita Kooistra plus talented customers like Eve Eisenstein and Emma Kassel.



For our Seminar this year we have been promised the lady who is considered the top authority in the world on the 910, the 840, the 710, and the 120 plus all of the Accessories. Her name is Yukiko Mitsumata and she will be coming to us from the factory in Japan that produces these excellent machines for KNITKING. Yukiko will be here to demonstrate, teach and answer all of your questions... so start listing them and have them all ready for the KNITKING ANNUAL SEMINAR and OPEN HOUSE October 12th through October 17th... Be sure to also bring your address book as you will meet and make new friends from all over the U.S. and many other countries throughout the world.



Another reminder... this one for residents of California... KNITKING has a permanent Booth at the Los Angeles County Fair... This will be our 28th year of continuous exhibition. We always have a wonderful display of garments... all of our Machines and most of the Accessories will be available at the exhibit, but although our space is large - four booths in one area - we have no room for yarns. We are in the HOME BUILDING No. 6 and the Fair runs from September 10th through September 27th... Please stop by and say "Hello"...

# Pattern Symbols

## Knitting – Chart Symbols

- ( ) Size Symbols (2nd Size)
- < > 3rd Size
- ① Color Number
-  Cast on
-  Stitch
-  Row
-  Hem
-  Bind off
-  Stockinette stitch – worn on the Knit side.
-  Stockinette stitch – worn on the Purl side.
-  Knit 1, Purl 1 Ribbing
-  Ribbing Pattern – worn on the Knit side.
-  Ribbing Pattern – worn on the Purl side.
-  Closed Dart
-  Open Dart
-  Put on a stitch holder
-  Reverse 1 section
-  On every other needle
-  Number of Rows between Shapings. Make increase (or decrease) FIRST, then knit 4 rows. For example: 3 x 1  means decrease (or increase) 1 st., knit 4 rows; decrease 1 st., knit 4 rows; decrease 1 st., knit 4 rows; decrease 1 st., knit 4 rows. All decreasing (or increasing) without row numbers as shown must be shaped on every 2nd row.





-  Increase
-  Increase 2 sts. With a transfer tool, move the sts. over the left (or right) leaving 2 empty needles at the point of increase. At the increase point, move 1 st. to the left, (or right) so that there is an empty needles on each side of a stitch. On each side of the center stitch, pick up a stitch from the row below and hang it onto the empty needle.

-  3 stitches on 1 needle. The 1st and 3rd stitch in a group of 3 has been hung on the 2nd or center needle.
-  Short Row increase or decrease; for instance on a flared skirt knitted sideways.









-  Pattern Stitch
-  Pattern Stitch – worn on the Knit side.
-  Pattern Stitch – worn on the Purl side.

-  Repeat
- I = Front
- II = Back
- III = Sleeve
- IV = Skirt Front
- V = Skirt Back
- VI = Collar
- VII = Pocket
- VIII = Band
- IX = Belt
- X = Cuff
- XI = Pants Front
- XII = Pants Back

## Finishing – Chart Symbols

-  Match numbers on section for assembling.
-  Ease
-  Fold Line
-  Turn to the wrong side and hem.

## Stitch Symbols

-  Needles in holding position
-  Needles back into working position.
-  Empty needle (leave in working position)
-  Needle not used (in the out of work position).
-  Two stitches on 1 needle, either transferred from the right side or the left side, then put into holding position.
-  Needle holding 2 stitches. Stitch has been transferred from the RIGHT.
-  Needle holding 2 stitches. Stitch has been transferred from the LEFT.
-  Center of garment section



# General Instructions

## HOW TO READ THE CHARTS AND INSTRUCTIONS

There are 3 sizes given for each Pattern in KNITKING MAGAZINE. Above each Chart for the different sizes, you will see that the first and smaller sizes might be shown as 8/10, the second size as (12/14) and the third as [16/18]. Check the measurements at the bustline and hips on the Charts to be certain that you will knit the correct size, remembering these are ACTUAL measurements of the completed section and that there must be a bigger allowance at the bustline and hipline for a Jacket or a Coat than there would be for a fitted dress or a fitted blouse or pullover. The question in your mind should be "How do I want this garment to fit...?"

When you have chosen the size you need, you can follow the Charts as shown. You will notice that where the shapings are the same FOR ALL SIZES, only 1 set of shapings will be shown on the first Chart and if you are knitting the 2nd or 3rd size, you simply follow the shapings as given for the first size. If the shapings are different, this will be shown on the Charts and you should follow them as given.

On the Charts, increases and decreases will be shown as follows

5x1  
6 The number in the box means number of ROWS between the shapings, while the 5x1 above the box means - 1 st. 5x... so you will increase or decrease 1 st. every 6th row 5x.

ARMHOLE SHAPINGS - NECK SHAPINGS - SHOULDER SHAPINGS - are made on every 2nd row UNLESS there is a number in a box along side or below the shapings. The rule is... where there is no box with a number, the shaping is made on every 2nd row.

## THE PRINTED INSTRUCTIONS

You can follow the printed instructions or use them in combination with the Charts. Where there is any question in the printed instructions, you have the Charts to show you how the section will look.

The 3 sizes, with the different amounts of cast on stitches and the different shapings will look like this...

Cast on 124 (136) [148] sts. You will  
Cast on 124 sts. for the first size.  
Cast on 136 sts. for the 2nd size.  
Cast on 148 sts. for the 3rd size.

The important thing to remember is that you MUST READ AHEAD so that you KNOW what to do for the size you are knitting. Sometimes where the number of stitches are the same but the number of times different, you will find shapings like this... 3 sts. 1x (2x) [3x], 2 sts. 1x (2x) [3x], 1 st. 3x (4x) [5x]. As you see, you MUST read ahead in order to follow the instructions as given for YOUR SIZE. The rows will be different for the different sizes in some cases... Shoulder and Neck shapings usually are worked at the SAME TIME for the back section - so watch for the words AT THE SAME TIME.

## HOLDING STITCHES ON THE LEFT SIDE WHILE SHAPING THE RIGHT SIDE

When knitting a section of garment in stockinette stitch, it is easy to hold the stitches on the left side while knitting the right half, but when knitting a Pattern Stitch such as a Norwegian Design, a Holding Position Design, Weaving, etc., you should use the following method. For the NECK SHAPING, we tell you to bind off the center sts., put the needles on the left into holding position and complete the right half first... so with a strand of contrast yarn, knit ALL of the left side stitches manually by hand, pulling each stitch back against the needle bed to the OUT OF WORK position. When the right side is completed, carefully pull the stitches held on contrast, forward into working position and as you do so, undo the contrast yarn, line up the needles (KNITKING AM 3 machine owners, put the stitches under the sinkers) and complete the left half.

If you own a Japanese machine, you may find that when knitting the right half with the left side held in this way, the sinker plate will mark the left side while you are knitting the right half. To prevent this marking, you can tape a piece of paper over the knitting, underneath the sinkers, or if you own a Reversing Bar, you can hang this onto the Sinkers while you are knitting the right half. When hanging the Reversing Bar, be sure the eyes of the bar go BETWEEN the Sinker Posts on the upper part of the bar so that the tips of the bar only - show above the needle bed.

## FULL FASHION DECREASING OR INCREASING

For Stockinette stitch, always use the Full Fashion method for increasing or decreasing.

TO DECREASE: Hang the 3rd stitch onto the 2nd stitch then move the stitches in to fill the empty needle.

TO INCREASE: Move the 2 end stitches 1 needle outward, then pick up the 3rd stitch from the row below and hang it onto the empty needle.

FINISHING: Block all sections. For PULLOVERS, JACKETS, and DRESSES: Join front to back at sides and shoulders. Sew sleeves together and set in. Hem lower edge and sleeve edges if needed. For a double neckband or armhole band, sew 1 edge to the inside and 1 to the outside of neck or armhole. For a single ribbed band, sew 1 edge to the outside of neck or armhole edge. For a cardigan or jacket with buttonholes, finish buttonholes and sew on buttons.

PANTS: Join front to back at sides. Sew inside leg seams, then join center front and back. Make hem at waistline and insert elastic. Hem lower edge of pants legs.

## THE SAMPLE SWATCH

Before you begin to knit any garment, you will need to knit a sample piece using the yarn you have chosen for your garment, so that you can check the stitch and row gauge which must measure the correct number of stitches and rows in 5 cm (2 inches).

For each Pattern in KNITKING MAGAZINE, we give you 3 tension numbers to work from and if you use the specified yarn for the garment, you should be able to get the correct stitch and row gauge using one of these numbers. Here is a very easy way to make your sample swatch and count the stitches and rows without actually counting, by using our KNITKING Converta Tape.

Supposing the Tension Numbers for the Stitch and Row Gauge are given as 5 to 7. Set the Tension Dial to the first number which is 5. With contrast waste yarn, and using the quick cast on method, cast on 60 stitches and knit 10 rows. Change to garment yarn and turn the Row Counter to 0. Knit 30 rows. Counting from each end, knit the 10th stitch on each side by hand with a small piece of contrast yarn. Leave the needles in working position and knit 30 rows (Row 60), then knit 4 rows with contrast waste yarn. Turn the Row Counter to 0 and the Tension Dial to 6 and with garment yarn, knit 30 rows. Mark the 10th stitch on each side as you did before, knit 30 rows, then 4 rows with contrast waste yarn. Turn the Row Counter to 0 and with Tension 7, repeat the above once more, ending with 10 rows of contrast waste yarn. Remove the work from the machine by passing the Slide across the needles without yarn (sometimes called 'dropping').

Pull and stretch the sample piece both lengthwise and diagonally from corner to corner, then lengthwise again. Do not count the stitches and rows immediately, but allow the sample to rest for several hours or even over night. This will allow the stitches and rows to return to their basic form.

When your sample has rested and you are ready to count the stitches and rows, the KNITKING CONVERTA TAPE will do the counting for you without any counting on your part. Use the Tape as follows:

Measure the stitches with the TAPE, BETWEEN the 40 stitches marked with contrast waste yarn. Push the SLIDE so that the LEFT EDGE lines up to this exact measurement. Now look down along side the SLIDE and find the number 40 on the TAPE. The number directly opposite on the SLIDE will be your Stitch Gauge to 5 cm (2"). To find the number of rows in 5 cm (2"), place the TAPE to measure over the 60 rows, push the SLIDE to this number with the left edge lined up, the look for the number 60 on the TAPE and directly opposite this will be the number of rows to 5 cm (2")

If you do not own a KNITKING CONVERTA TAPE, you must mark a 5 cm (2 inch) square in the center of the knitting, then count the number of stitches and rows within the square.

# KK959

## GIRL'S JUMPER & KNEE SOCKS

**SIZES:** 4 (6)  
**YARN:** Amore  
**GRAMS:**  
 color 1 250 250  
 color 2 50 50  
 color 3 50 50  
 color 4 50 50  
**TENSION:** 6 to 8  
**GAUGE:** 13 1/2 sts. 19 rows = 5 cm (2")

Stockinette stitch with a Norwegian Border Design. Yoke is striped.

**FINISHING:** See General Instructions. Work 1 row single crochet around neck and armholes then 1 row reverse single crochet.

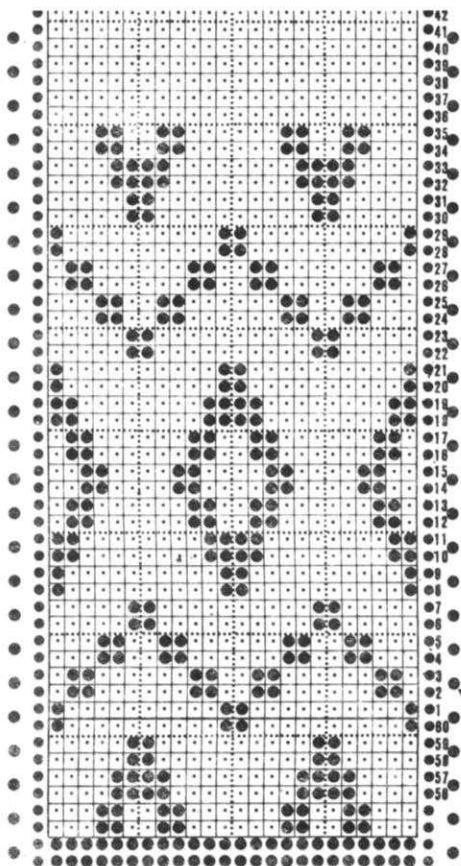

### BEGIN HERE

- 6 Rows colors 1 & 2
- 8 Rows colors 1 & 3
- 14 Rows colors 1 & 4
- 8 Rows colors 1 & 3
- 6 Rows colors 1 & 2

### YOKE:

Cast on 150 sts. with color 1 and work Stockinette stitch with color stripes, changing the tensions as follows: 12 rows Tension 10, 6 rows Tension 9, 6 rows Tension 8 and 12 rows Tension 5 and at the same time working 4 rows color 1, 2 rows color 4, 2 rows color 3, 2 rows color 2, 4 rows color 1, 2 rows color 2, 2 rows color 4, 2 rows color 3, 4 rows color 1, 2 rows color 2, 2 rows color 3, 2 rows color 4, 6 rows color 1. Bind off.

### SOCKS:

Cast on 48 sts. with color 1 and work Stockinette stitch. After Row 8, make a picot - transfer every 2nd st. to neighboring needle and leave empty needle in work. Knit to Row 18 then hang the hem. Continue in the Norwegian Design to Row 64. Continue in Stockinette stitch with color 1. After Row 104, ON EACH SIDE, remove 12 sts. onto a stitch holder. Knit to Row 156. \*WORK SHORT ROWS: Put into holding position 1 st. 7x ON EACH SIDE, After Row 170, bring back into working position 1 st. 7x.\* Knit to Row 224. Work the SHORT ROWS same as before from \* to \*. Knit to Row 268 and remove the sts. onto a stitch holder. Weave the heel sts. to the leg sts. and sew up back seam. Sew sides of foot.

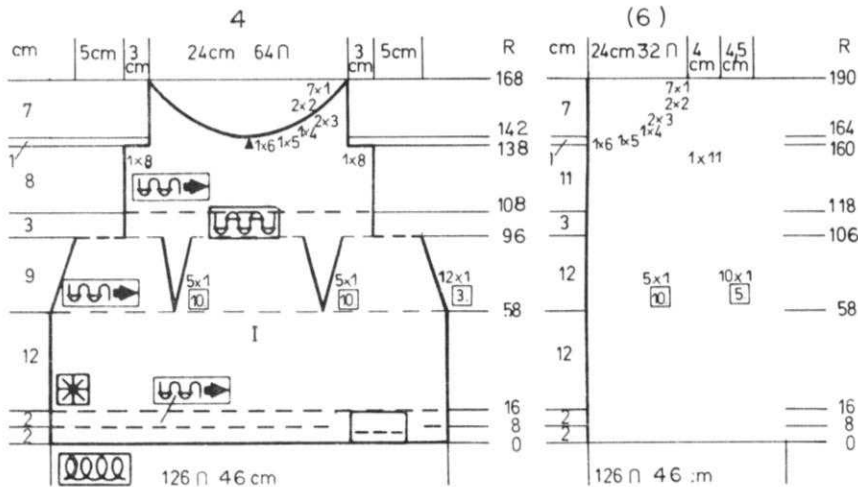
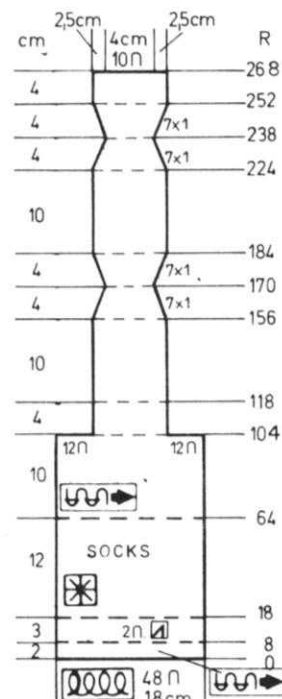

### FRONT: I

Work the front the same as the back to Row 108 (118). Knit to Row 138 (160). ON EACH SIDE, bind off 8 (11) sts. then knit to Row 142 (164). Put half the sts. on the left into holding position and complete the right side first. \*ON NECK SIDE, bind off 6 sts. 1x, 5 sts. 1x, 4 sts. 1x, 3 sts. 2x, 2 sts. 2x, 1 st. 2x for both sizes. Bring the needles on the left into working position and complete the left half. Follow the instructions from \*.

BACK: II

Cast on 126 (126) sts. with color 1 and work Stockinette stitch. With lower tension knit 8 rows, work 1 row with larger tension then with garment tension knit to Row 18 and hang the hem. Continue in the Norwegian Design to Row 58, then continue in Stockinette stitch with color 1. Divide into 3rds and work 1 section at a time, following the chart for the decreases on each side. Remove each section onto waste yarn and remember to turn the Row Counter back to 58 each time you knit a section. Hang the sts. together back onto the machine and work 12 rows K1, P1 Ribbing. Transfer the Ribber sts. to main machine and continue in Stockinette stitch with color 1. Counter at 108 (118). Knit to Row 138 (160). ON EACH SIDE, bind off 8 (11) sts. then knit to Row 160 (182). SHAPE NECK: Put half the sts. on the left into holding position and complete the right side first. \*ON NECK SIDE, bind off 11 sts. 1x, 6 sts. 1x, 5 sts. 1x, 4 sts. 1x, 2 sts. 3x for both sizes. Bring the needles on the left into working position and complete the left half. Follow the instructions from \*.

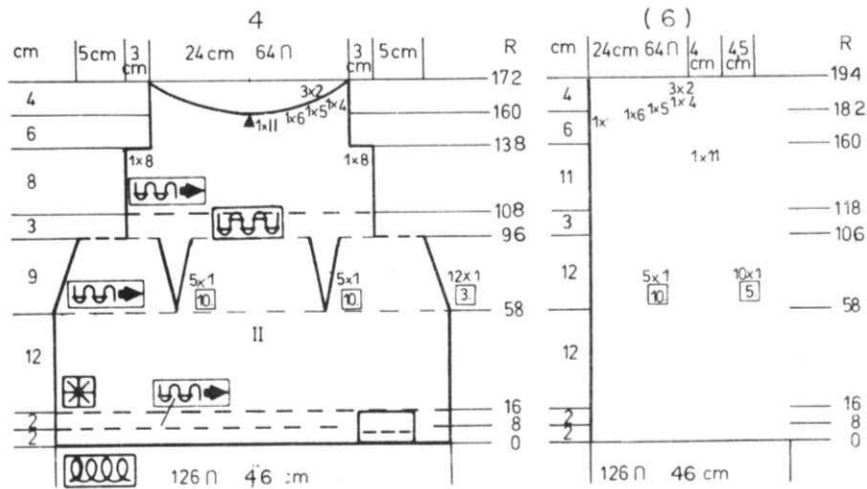

# KK960

## GIRL'S SKIRT & JACKET VEST

SIZES: 4 (6)  
 YARN: Amore  
 GRAMS: 400 450  
 TENSION: 6 to 8  
 GAUGE: 13 1/2 sts. 19 rows = 5 cm (2")

The sleeves of Jacket and the Skirt are made using the Ribber. There are 7 sts. on main machine and 1 st. on Ribber. The main section of Jacket is in Stockinette stitch. The purl side is the right side.

FINISHING: See General instructions. Turn front bands over to the inside and sew in place. Sew on Waistband, fold to the inside and sew in place. Finish Buttonholes and sew on Buttons.

FRONT: I Make 1, reverse 1.

Cast on 67 (69) sts. and work Stockinette stitch. ON FRONT EDGE, cast on 3 sts. 1x, 2 sts. 1x and ON EVERY 3rd row decrease 1 st. FULL FASHION method 42 (45)x and AT THE SAME TIME, after Row 50 (54) SHAPE ARMHOLE same as the back. After Row 100 (106) SHAPE SHOULDER: Bind off 5 sts. 3x, 6 sts. 1x. Continue with band to Row 136 (136) then bind off 3 sts. 1x, 2 sts. 1x.



### JACKET WAISTBAND:

Cast on 18 sts. and work Stockinette stitch. After Row 8, make 2 buttonholes over needles 4 and 5 counting from each end. REPEAT the buttonholes after Row 53 (57). Knit to Row 266 (281) then bind off.

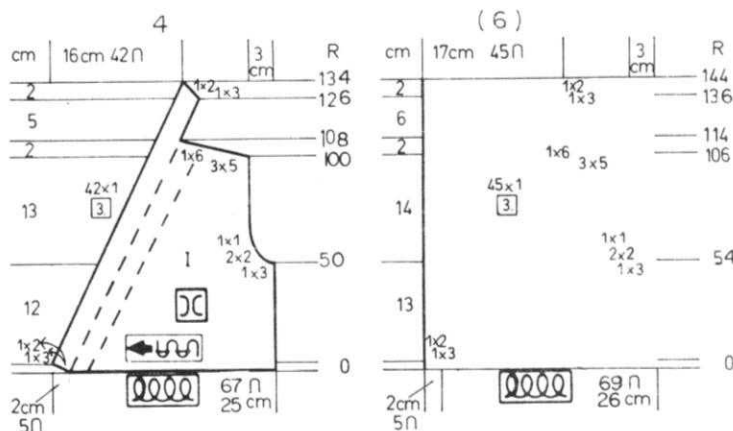

# KK960

BACK: II

Cast on 86 (90) sta. and work Stockinette stitch.

Knit to Row 50 (54).

SHAPE ARMHOLE: ON EACH SIDE, bind off 3 sts. 1x, 2 sts. 2x, 1 st. 1x for both sizes.

Knit to Row 104 (110).

Bind off the center 20 sts., put the needles on the left into holding position and complete the right side first.

\*SHAPE SHOULDER AND NECK AT THE SAME TIME.

FOR SHOULDER, bind off for both sizes, 5 sts. 3x, 6 sts. 1x.

FOR NECK, bind off 2 sts. 2x (3x).

Bring the needles on the left into working position, knit 1 row to the left side, turn the Row Counter back to 104 (110) and complete the left half. Follow the instructions from \*.

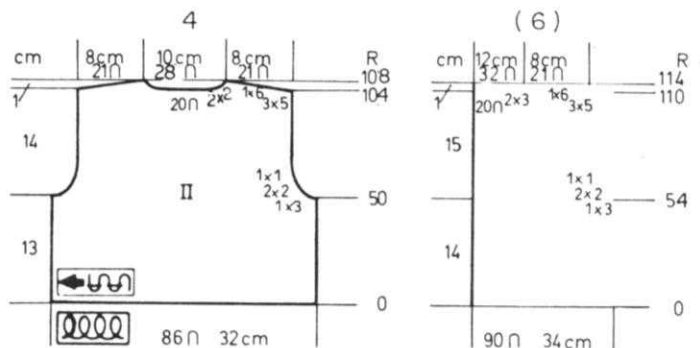

SLEEVES: III

Cast on 54 (58) sts. and work 20 rows Ribbing.

Continue in Pattern with 7 sts. on main machine and 1 st. on the Ribber.

ON EACH SIDE, increase 1 st. every 12th row 8x.

After Row 114 (118) SHAPE CAP: Please follow the Chart in your size for the bind-offs on each side.

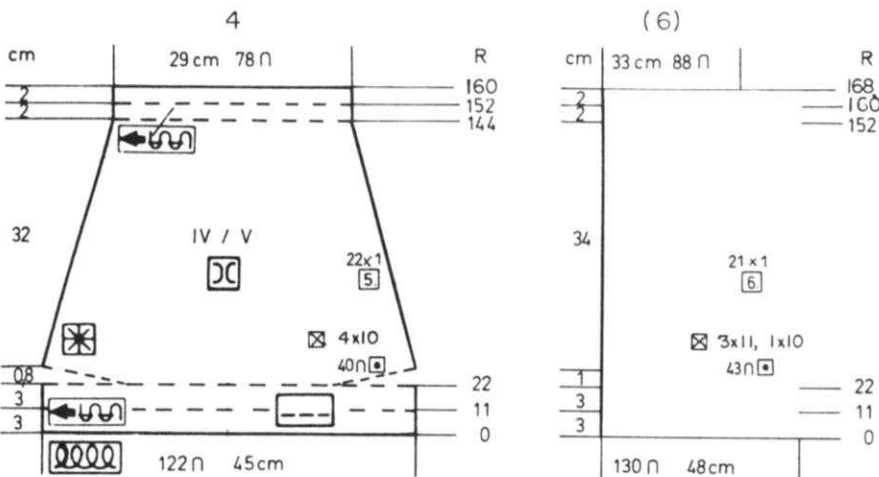
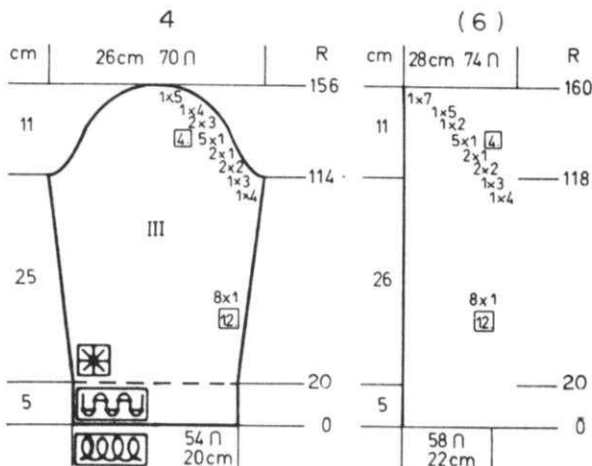

SKIRT: IV/V Two sections the same.

Cast on 122 (130) sts. and work 11 rows Stockinette stitch then set up the needles same as sleeve pattern with 7 sts. on main machine, 1 st. on the Ribber.

After Row 22, work SHORT ROWS.

ON OPPOSITE SIDE OF SLIDE, put into holding position 40 (43) sts. before knitting the next two rows.

ON OPPOSITE SIDE OF SLIDE, bring back into working position 10 sts. 4x.

(11 sts. 3x, 10 sts. 1x).

ON EACH SIDE, decrease 1 st. every 5th row 22x.

(every 6th row 21x).

After Row 144 (152) continue in Stockinette stitch to Row 160 (168). Bind off loosely.

# KK961

CHILD'S PULLOVER & SOCKS

SIZES: 6/8 (10)

YARN: Amore

GRAMS:

color 1 250 300

color 2 50 50

color 3 50 50

color 4 50 50

TENSION: Pattern A - 5 to 7

Pattern B - 7 or 8

Bands - 6 or 7

GAUGE: 14 1/2 sts. 22 1/2 rows = 5 cm

for Pattern A

14 1/2 sts. 19 1/2 rows = 5 cm

for Norwegian (B)



A Norwegian Design plus a Tuck Stitch Pattern. If you want to use the Tuck Stitch on the Purl side, you must reverse the knitting after working the Norwegian Design and for the color stripes on the Sleeves. Punch your own Cards.

FINISHING: See General Instructions. Sew on Bands on front and neck edge of Pullover. Socks: Weave the heel sts. to leg section then sew up back seam and foot seams.



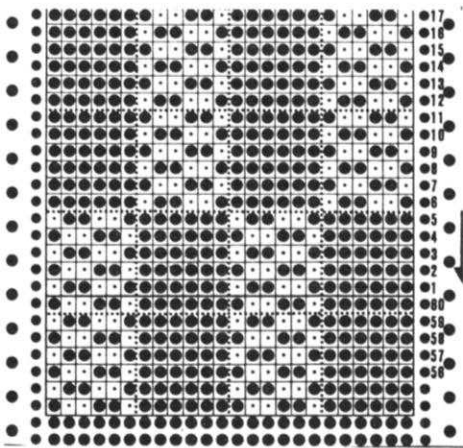

**PATTERN A**

REPEAT PUNCH CARD THROUGH ROW 41 then Punch 2 rows of holes for connecting Card.

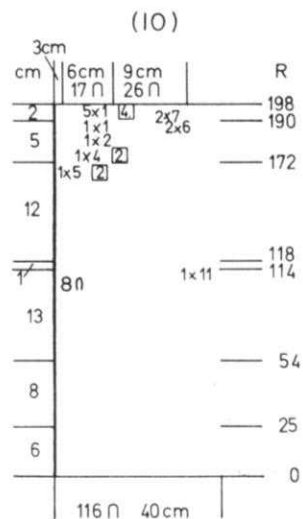
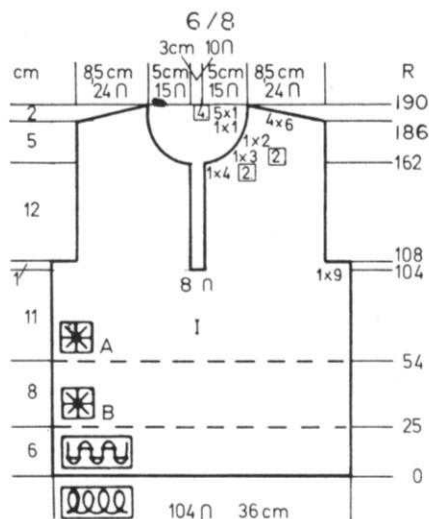

**PULLOVER FRONT: I**

Work the front the same as the back to Row 104 (114). Bind off the center 8 sts., put the needles on the left into holding position and complete the right side first.

\* After Row 108 (118), bind off 9 (11) sts. then knit to Row 161 (171).

ON NECK SIDE, bind off 4 sts. 1x, 3 sts. 1x, 2 sts. 1x, 1 st. 1x, then 1 st. every 4th row 5x AND AT THE SAME TIME, after Row 182, SHAPE SHOULDER same as the back. (5 sts. 1x, 4 sts. 1x, 2 sts. 1x, 1 st. 1x, 1 st. every 4th row 5x AND AT THE SAME TIME, after Row 190 SHAPE SHOULDER same as the back. Bring the needles on the left into working position, knit 1 row in Pattern to the left side, turn the Row Counter back to 104 (114) and complete the left half. Follow the instructions from \*.

6 / 8

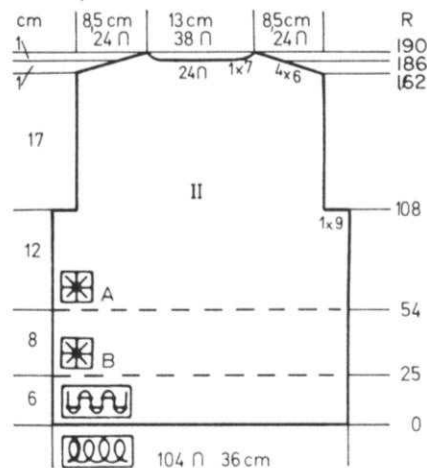

(10)

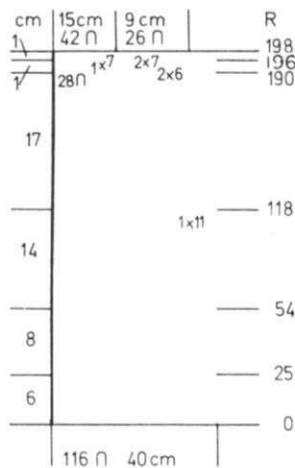

**PULLOVER BACK: II**

Cast on 104 (116) sts. with color 1 and work 25 rows Ribbing. Continue in Pattern B to Row 54. Continue in Pattern A.

After Row 108 (118), SHAPE ARMHOLE: ON EACH SIDE, bind off 9 (11) sts. then knit to Row 182 (190).

SHAPE SHOULDER and Watch for NECK SHAPING.

FOR SHOULDER, on each side, bind off 6 sts. 4x

(6 sts. 2x, 7 sts. 2x)

FOR NECK: After Row 186 (196) bind off the center 24 (28) sts. put the needles on the left into holding position and complete the right side first.

\*ON NECK SIDE, bind off

7 sts. 1x for both sizes.

Bring the needles on the left into working position and complete the left half. Follow the instructions from \* and don't forget to complete the shoulder shaping (Row Counter 186 (196)).

(10)

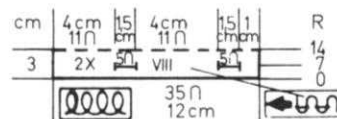

GR I / (II)

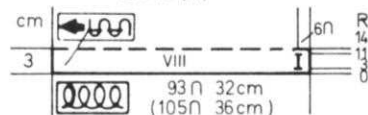

**NECKBAND: VIII**

Cast on 93 (105) sts. with color 1 and work Stockinette stitch - 4 rows color 1, 2 rows color 4, 2 rows color 3, 2 rows color 2, 2 rows color 1. Bind off

**PATTERN B BEGIN HERE**

- 6 rows colors 1 & 2
- 6 rows colors 1 & 3
- 10 rows colors 1 & 4
- 6 rows colors 1 & 3
- 6 rows colors 1 & 2

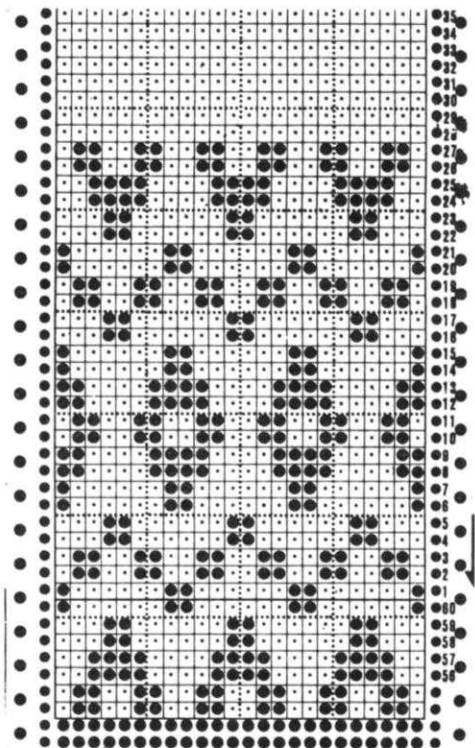

# KK961

## SOCKS:

Cast on 85 sts. with color 1 and work K2, P2 Ribbing with color stripes as follows:  
 4 rows color 1, 2 rows color 4,  
 2 rows color 3, 2 rows color 2,  
 4 rows color 1, 2 rows color 4,  
 2 rows color 3, 2 rows color 2  
 4 rows color 1.

After Row 24, continue in Pattern B AND AT THE SAME TIME, ON EACH SIDE, decrease 1 st. every 3rd row 16x (17x).

Knit to Row 110 (137).

ON EACH SIDE, remove 13 (15) sts. onto a stitch holder then continue in Stockinette stitch.

After Row 83 (225), work SHORT ROWS.

\*ON OPPOSITE SIDE OF CARRIAGE, put into holding position 2 sts. 4x, 1 st 1x ON EACH SIDE. ON OPPOSITE SIDE OF CARRIAGE, bring back into working position 1 st. 1x, 2 sts. 4x.\*\*

Knit to Row 273 (330) and REPEAT the Short Rows from \* to \*\*. Knit to Row 321 (378) then remove the sts. onto a stitch holder.

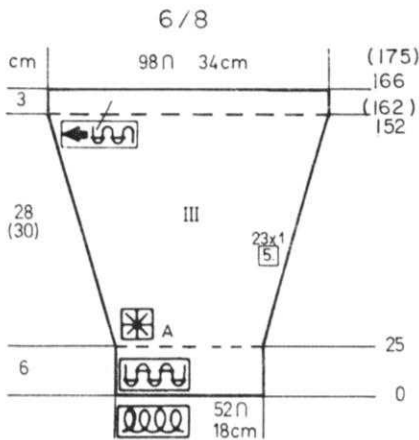
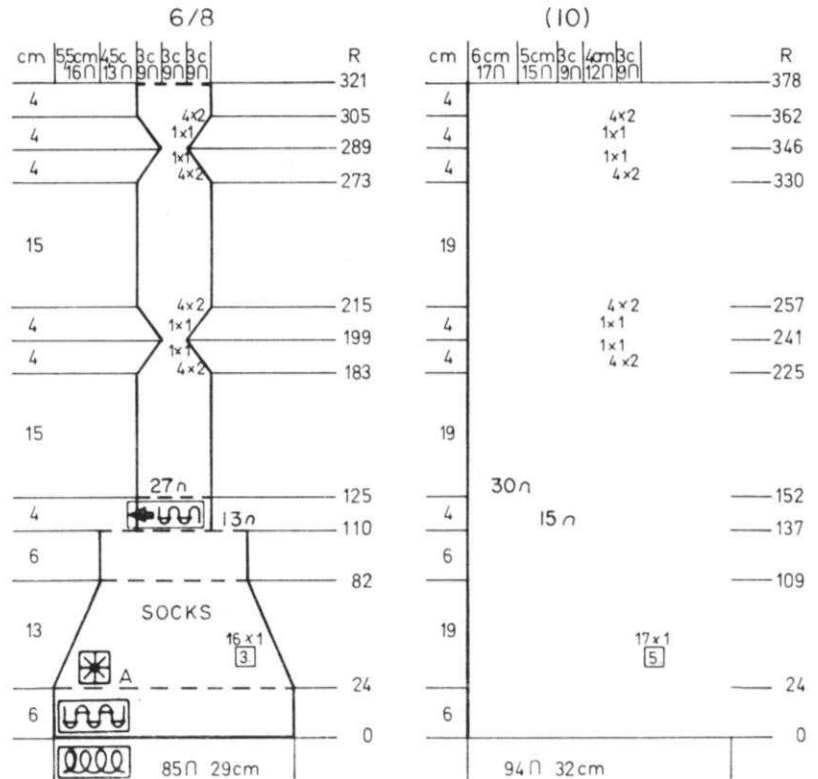

## SLEEVES: III

Cast on 52 sts. with color 1 and work 25 Rows Ribbing. Continue in Pattern A. ON EACH SIDE, increase 1 st. every 5th row 23x. Knit to Row 152 (162), then work the color stripes same as for front and neck bands. After Row 166 (176), bind off.

## FRONT BANDS: Make 2.

Cast on 35 sts. with color 1 and work Stockinette stitch with color stripes same as Neckband. After Row 14, bind off. Make 2nd band with BUTTONHOLES, spacing 2 as shown on the Chart.

# HP962

## MAN'S PULLOVER

SIZES: 34/36 (40/42)  
 YARN: Fortissima  
 GRAMS: color 1 150 150  
 color 2 150 150  
 color 3 100 100  
 TENSION: 6 to 8  
 GAUGE: 15 1/2 sts. 21 rows = 5 cm (2")

Stockinette stitch with color stripes as shown on the Chart. Bands are K1, P1 Ribbing.

FINISHING: See General Instructions.



## SLEEVES: III

Cast on 74 (80) sts. with color 1 and work 37 rows Ribbing. Continue with Stockinette stitch and color stripes same as the front and back after the rows as shown on the chart. AT THE SAME TIME, ON EACH SIDE, increase 1 st. every 8th row 28x (29x). After Row 235 (243), bind off.

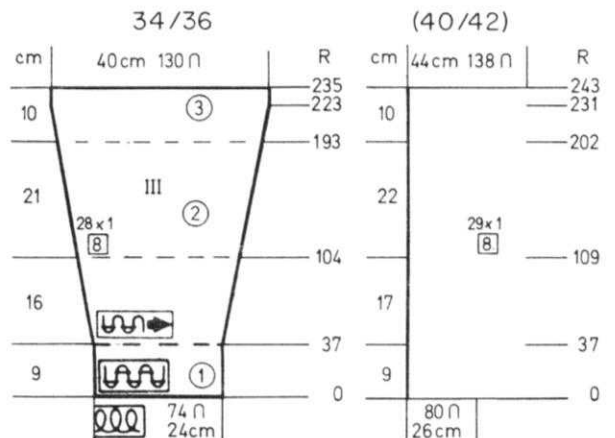

FRONT: I

Work the front the same as the back except for neck shaping. After Row 236 (252), bind off the center 8 (10) sts., put the needles on the left into holding position and complete the right side first.

\*ON NECK SIDE, bind off 4 sts. 1x, 3 sts. 2x, 2 sts. 3x, 1 st. 7x. (3 sts. 3x, 2 sts. 5x, 1 st. 7x). After Row 252 (274), SHAPE SHOULDER same as the back. Bring the needles on the left into working position, knit 1 row to the left side, turn the Row Counter back to 236 (252) and complete the left half. Follow the instructions from \*.

34/36

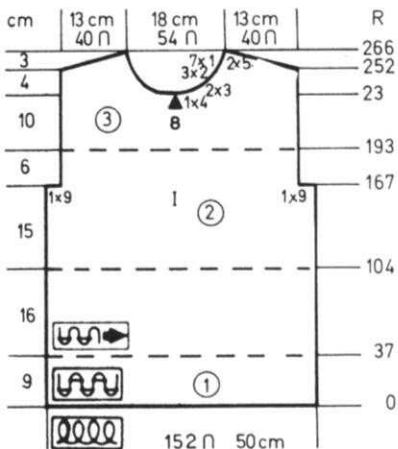

(40/42)

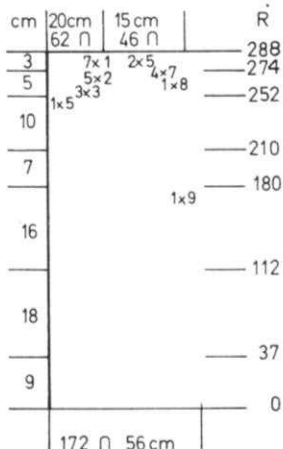

NECKBAND: VI

Cast on 154 (172) sts. with color 3 and work 38 rows Ribbing. Bind off.

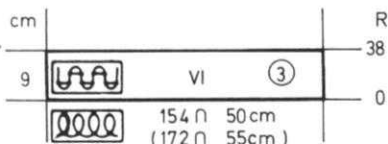

34/36

(40/42)

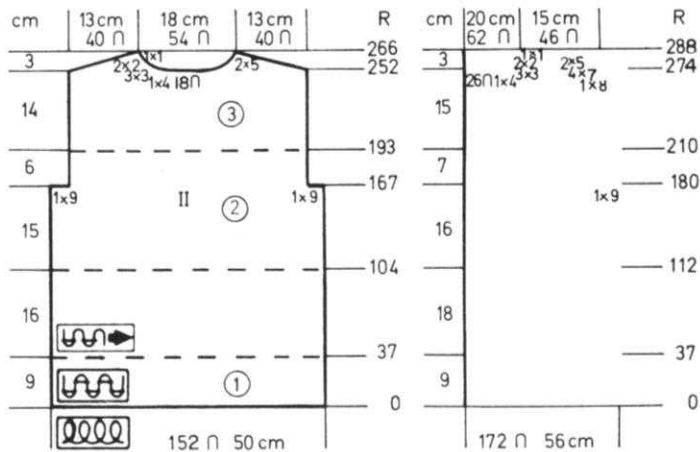

BACK: II

Cast on 152 (172) sts. with color 1 and work 37 Rows Ribbing. Continue in Stockinette stitch. After Row 104 (112), work color stripes of 2 rows color 2, 2 rows color 1, 2 rows color 2, 2 rows color 1. Continue with color 2. After Row 167 (180), SHAPE ARMHOLE: ON EACH SIDE, bind off 9 sts. after Row 193 (210), work the color stripes as follows: 2 rows color 3, 2 rows color 2, 2 rows color 1, 2 rows color 2. Continue with color 3. After Row 252 (274), bind off the center 18 (26) sts., put the needles on the left into holding position and complete the right side first. \*SHAPE SHOULDER AND NECK AT THE SAME TIME. FOR SHOULDER, bind off 6 sts. 5x, 5 sts. 2x. (8 sts. 1x, 7 sts. 1x, 5 sts. 2x). FOR NECK, bind off for both sizes 4 sts. 1x, 3 sts. 3x, 2 sts. 2x, 1 st. 1x. Bring the needles on the left into working position, knit 1 row to the left side, turn the Row Counter back to 252 (274) and complete the left half. Follow the instructions from \*.

DK963

WOMAN'S PULLOVER

SIZES: 10/12 (14)  
 YARN: Amore  
 GRAMS: color 1 300 350, color 2 100 100, color 3 100 100, color 4 100 100  
 TENSION: 5 to 7  
 GAUGE: 15 sts. 21 rows = 5 cm (2")



A Norwegian Design is used for the top part of Pullover and Stockinette stitch for the lower section. Bands are K1, P1 Ribbing. Punch your own Card.

FINISHING: See General Instructions.

\*8 Rows colors 1 & 2  
 7 Rows colors 3 & 2  
 8 Rows colors 3 & 4  
 7 Rows colors 1 & 4  
 REPEAT FROM \* for color changes.

REPEAT THE PUNCH CARD through Row 53 then punch 2 rows of holes for connecting card.

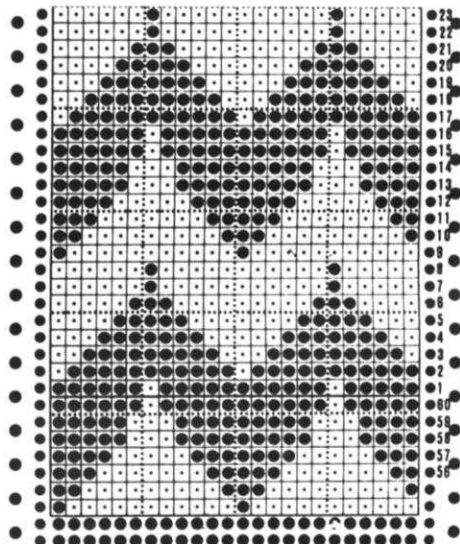

FRONT: I

Work the front the same as the back to Row 244 (248). Bind off the center 16 sts., put the needles on the left into the holding position and complete the right side first.  
 \*ON NECK SIDE, bind off 4 sts. 1x, 3 sts. 1x, 2 sts. 2x, 1 st. 5x for both sizes, then after Row 256 (260), SHAPE SHOULDER same as the back.  
 Bring the needles on the left into working position, knit 1 row in Pattern to the left side, turn the Row Counter back to 244 (248) and complete the left half. Follow the instructions from \*.

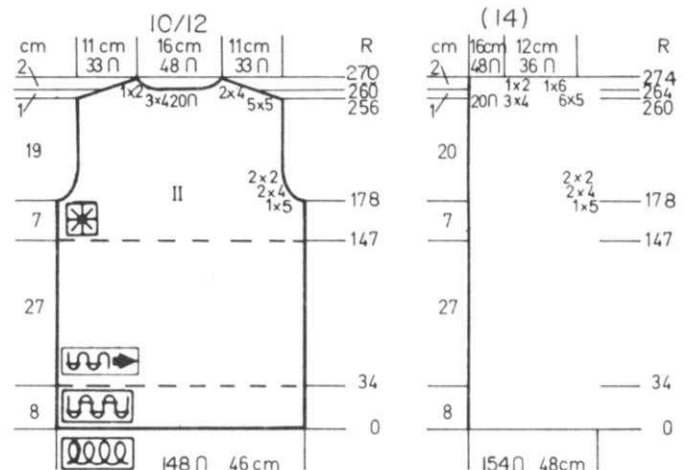
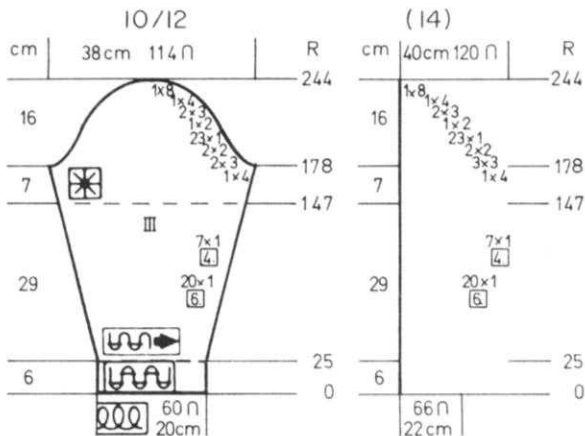
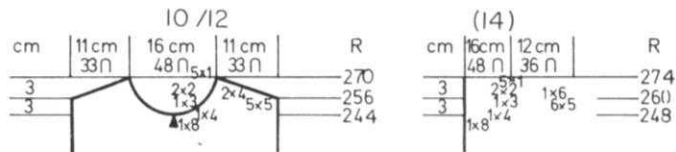

BACK: II

Cast on 148 (154) sts. with color 1 and work 34 rows Ribbing. Continue in Stockinette stitch to Row 147 then set Punch Card from left to right and continue in Norwegian Design following the color changes as shown along side the Card.  
 After Row 178 SHAPE ARMHOLE: ON EACH SIDE, bind off 5 sts. 1x, 4 sts. 2x, 2 sts. 2x for both sizes.  
 Knit to Row 256 (260).  
 SHAPE SHOULDER and watch for Neck Shaping.

FOR SHOULDER, ON EACH SIDE, bind off 5 sts. 5x, 4 sts. 2x. (5 sts. 6x, 6 sts. 1x).  
 FOR NECK, after Row 260 (264), bind off the center 20 sts., put the needles on the left into holding position and complete the right side first.

\*ON NECK SIDE, bind off 4 sts. 3x, 2 sts. 1x, for both sizes.  
 Bring the needles on the left into working position, knit 1 row in Pattern to the left side, turn the Row Counter back to 260 (264) and complete the left half. Follow the instructions from \* and don't forget to complete the shoulder shaping.

SLEEVES: III

Cast on 60 (66) sts. with color 1 and work 25 rows Ribbing. Continue in Stockinette stitch. ON EACH SIDE, increase 1 st. every 6th row 20x, every 4th row 7x for both sizes.  
 After Row 147 - Set Punch Card from left to right then continue in Pattern.  
 After Row 178, SHAPE CAP: ON EACH SIDE, bind off - Please follow the Chart in your size for the bind-offs on each side.

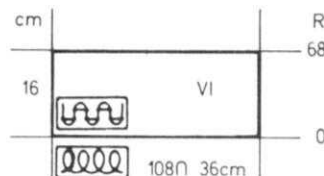

COLLAR: VI

Cast on 108 sts. and work 68 rows Ribbing. Bind off or remove onto waste yarn.

# HP964



## MAN'S PULLOVER

SIZES: 34/36 (38/40)  
YARN: Amore

GRAMS:  
color 1 350 400  
color 2 100 100  
color 3 100 100  
color 4 100 100

TENSION: 5 to 7  
GAUGE: 15 sts. 21 rows = 5 cm (2")

A Norwegian Design on the top section and top of sleeves with stockinette stitch for the lower section. Bands are K1, P1 Ribbing. Punch your own card and follow the color changes along side of Punch Card illustration.

FINISHING: See General Instructions.

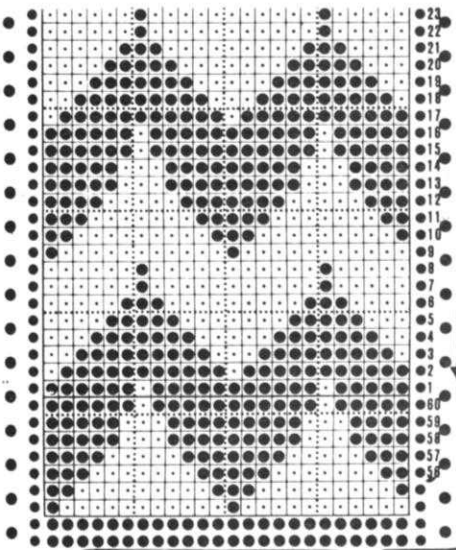

REPEAT THE PUNCH CARD through Row 53 then punch 2 rows of holes for connecting card.

\* 8 Rows colors 1 & 2  
7 Rows colors 3 & 2  
8 Rows colors 3 & 4  
7 Rows colors 1 & 4  
REPEAT FROM \*.

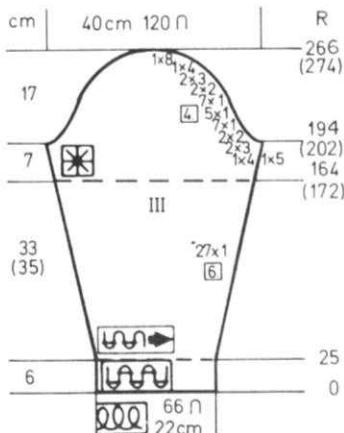

### SLEEVES: III

Cast on 66 sts. with color 1 and work 25 rows Ribbing. Transfer the Ribber sts. and continue in Stockinette stitch. ON EACH SIDE, increase 1 st. every 6th row 27x. Knit to Row 163 (171). Set Punch Card from left to Right and continue in Norwegian Design. After Row 194 (202) SHAPE CAP: Please follow the bind-offs ON EACH SIDE as shown on the Chart.

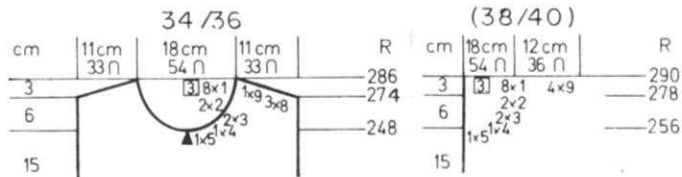

### FRONT: I

Work the front the same as the back to Row 248 (256). Put half the sts. on the left into holding position and complete the right side first. \*ON NECK SIDE, bind off 5 sts. 1x, 4 sts. 1x, 3 sts. 2x, 2 sts. 2x, 1 st. every 3rd row 8x for both sizes. AT THE SAME TIME, after Row 274 (278) SHAPE SHOULDER same as the back. Bring the needles on the left into working position, knit 1 row in Pattern to the left side, turn the Row Counter back to 248 (256) and complete the left half. Follow the instructions from \*.

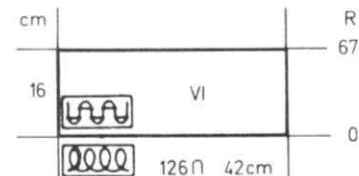

### COLLAR: VI

Cast on 126 sts. with color 1 and work 67 rows Ribbing. Bind off or remove onto waste yarn.

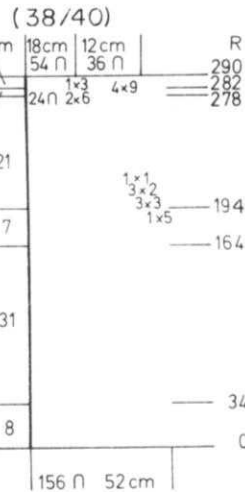
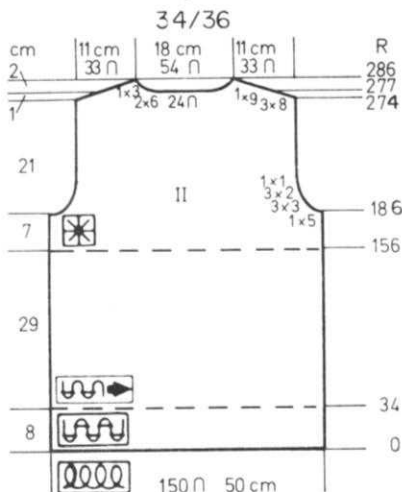

### BACK: II

Cast on 150 (156) sts. with color 1 and work 34 rows Ribbing. Continue in Stockinette stitch. Knit to Row 155 (163) then set Punch Card from left to right and continue in Norwegian Design. After Row 186 (194) SHAPE ARMHOLE: ON EACH SIDE, bind off 8 sts. 3x, 9 sts. 1x (watch for neck shaping). (9 sts. 4x) Watch for neck shaping. After Row 278 (282) SHAPE NECK: Bind off the center 24 sts., put the needles on the left into holding position and complete the right side first. \*ON NECK SIDE, bind off 6 sts. 2x, 3 sts. 1x for both sizes. Bring the needles on the left into working position, knit 1 row in Pattern to the left side, turn the Row Counter back to 278 (282) and complete the left half. Follow the instructions from \* and don't forget to complete the shoulder shaping.

# DK965

## WOMAN'S CARDIGAN

SIZES: 7/8 (10)  
 YARN: Amore  
 GRAMS:  
 color 1 300 350  
 color 2 50 50  
 color 3 50 50  
 color 4 50 50 4  
 TENSION: 5 to 6 Ribbing 4  
 GAUGE: 17 sts. 24 rows = 5 cm (2")



A Norwegian Design combined with Stockinette stitch. The bands are K1, P1 Ribbing. Punch your own Card.

FINISHING: See General Instructions Sew front bands in place and sew up back seam of band.

NOTE: Punch card and stop KC & MC when knitting stockinette stitch. There are 4 rows of design each time \*then knit 29 rows of Stockinette and THEN set Punch Card from left to right (Row 30 of Stockinette stitch) Work the 4 rows of design following the colors as shown on the Chart. Turn off KC and MC and continue from \* throughout.

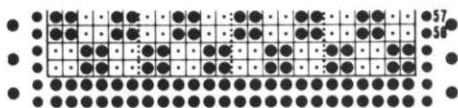

REPEAT THE PUNCH CARD THROUGH ROW 37 then punch 2 rows of holes for connecting Card.

FRONT: Make 1, reverse 1 and omit Buttonholes in left section.

Cast on 78 (84) sts. with color 1 and work 48 rows Ribbing, making Buttonhole after Row 12 over needles 3,4,5, 6 counting from the left edge. Transfer the Ribber sts. to main machine then remove 10 sts. on the left (right) onto a stitch holder for the band.

Work 8 (12) rows color 1 then work in Pattern to Row 144 (149).

After Row 144 (149) ON FRONT EDGE decrease 1 st. every 7th row 19x for both sizes and AT THE SAME TIME, after Row 178 (182) SHAPE ARMHOLE same as the back.

After Row 274 (284) SHAPE SHOULDER same as the back.

Pick up the sts. held on stitch holder then transfer the proper sts. to the Ribber and work in Ribbing. Counter 48. Make BUTTONHOLES over same needles as you did before after Rows 48 (49) 84 (86) 120 (123) 144 (149) Continue in Ribbing long enough to go around front edge and to the center of back neck. Remove onto waste yarn so you can weave the center of band.

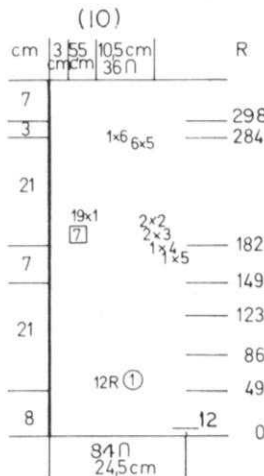
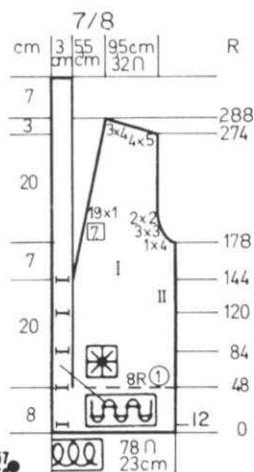

BACK: II

Cast on 144 (156) sts. with color 1 and work 48 rows Ribbing. Transfer the Ribber sts. to main machine.

and with color 1 begin with 8 (12) rows Stockinette stitch (Set Card after the 7th row) and continue in Pattern with color changes as shown on the Chart. After Row 178 (184), SHAPE ARMHOLE:

ON EACH SIDE, bind off 4 sts. 1x, 3 sts. 3x, 2 sts. 2x. (5 sts. 1x, 4 sts. 1x, 3 sts. 2x, 2 sts. 2x).

After Row 274 (284) SHAPE SHOULDER and WATCH FOR NECK SHAPING.

FOR SHOULDER, ON EACH SIDE, bind off 5 sts. 4x, 4 sts. 3x.

(5 sts. 6x, 6 sts. 1x).

FOR NECK, after Row 284 (294) bind off the center 20 sts., put the needles on the left into holding position and complete the right side first.

\*ON NECK SIDE, bind off 5 sts. 2x, 3 sts. 1x for both sizes.

Bring the needles on the left into working position, knit 1 row to the left side, turn the Row Counter back to 284 (294) and complete the left half. Follow the instructions from \* and don't forget to complete the shoulder shaping.

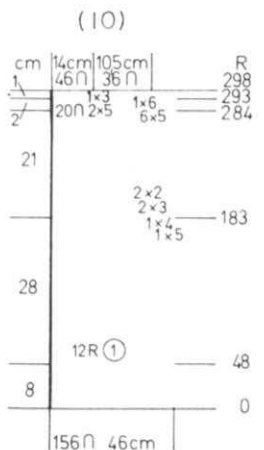
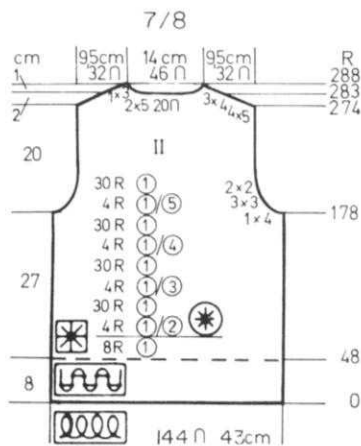

## SLEEVES: III

Cast on 68 (74) sts. with color 1 and work 48 rows Ribbing. Transfer the Ribber sts. to main machine and work 36 rows Stockinette stitch with color 1 then begin Pattern BUT AT THE SAME TIME, ON EACH SIDE, increase 1 st. every 6th row 27x for both sizes. after Row 208, SHAPE CAP. Please follow the cap shaping ON EACH SIDE as shown on the Chart for your size.

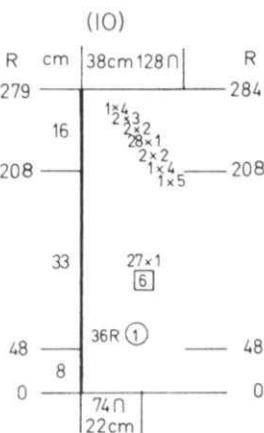
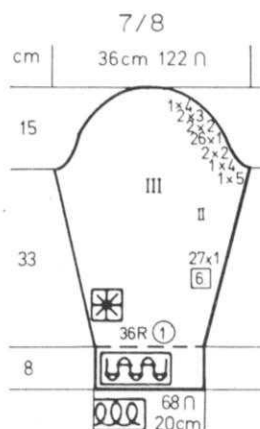

# DK966



## WOMAN'S SLEEVELESS PULLOVER

SIZES: 8/10 (12)

YARN: Amore

GRAMS: 200 200

Small amounts of different colors for embroidery - not included in Kit. (You can use leftovers from DK 965).

TENSION: 5 to 7

GAUGE: 17 sts. 24 rows = 5 cm (2")

Stockinette stitch with embroidered dots (see Picture) using different colors. Armhole and Neckbands are Stockinette stitch. Waistband is Mock Ribbing over every 2nd needle.

**FINISHING:** See General Instructions. Weave neck and arm bands to Pullover on the right side, then fold to the inside and sew in place. Remove the waste yarn. On the front, embroider dots in selection of colors. Every dot is 2 rows high and 2 sts. wide (see picture).

### BACK: II

Cast on 75 (80) sts. over EVERY 2nd NEEDLE and work Stockinette stitch to Row 20. Hang the hem and bring empty needles into working position (Mock Ribbing) You should now have 150 (160) sts. Continue in Stockinette stitch to Row 174 (178). **SHAPE ARMHOLE:** ON EACH SIDE bind off 5 sts. 1x, 3 sts. 1x, 2 sts. 2x, 1 st. 7x. (6 sts. 1x, 3 sts. 1x, 2 sts. 2x, 1 st. 8x. Knit to Row 270 (280). **SHAPE SHOULDER and WATCH FOR NECK SHAPING.** FOR SHOULDER, ON EACH SIDE, bind off 5 sts. 2x, 6 sts. 2x. (6 sts. 3x, 7 sts. 1x). AT THE SAME TIME, after Row 272 (282), bind off the center 40 sts. put the needles on the left into holding position and complete the right side first.

\*ON NECK SIDE, bind off 7 sts. 2x for both sizes. Bring the needles on the left into working position, knit 1 row to the left side, turn the Row Counter back to 272 (282) and complete the left half. Follow the instructions from \* and don't forget to complete the shoulder shaping.

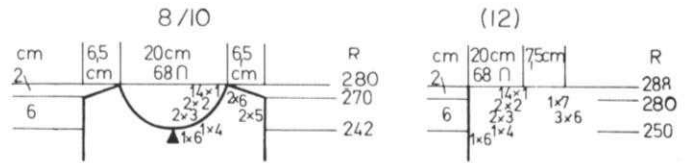

### FRONT: I

Work the front the same as the back to Row 242 (250). Put half the sts. on the left into holding position and complete the right side first.

\*ON NECK SIDE, bind off 6 sts. 1x, 4 sts. 1x, 3 sts. 2x, 2 sts. 2x, 1 st. 14x for both sizes and after Row 270 (280) **SHAPE SHOULDER SAME AS THE BACK.** Bring the needles on the left into working position, knit 1 row to the left side, turn the Row Counter back to 242 (250) and complete the left half. Follow the instructions from \*.

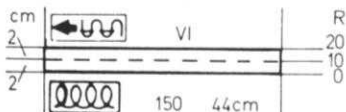
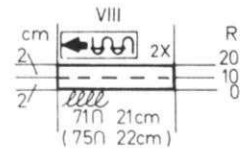
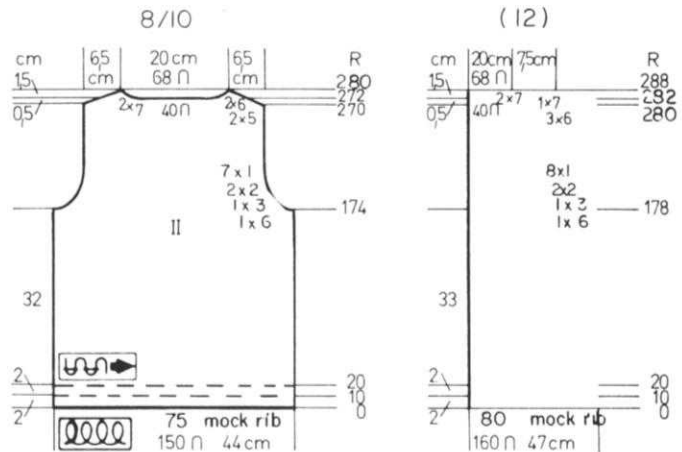

ARMHOLE BANDS: VI Make 2.

**OPEN CAST ON.** Work the open cast on same as for the Neckband. Cast on 71 (75) sts. and work same as Neckband. Remove onto waste yarn.

### NECKBAND: VI

**OPEN CAST ON.** With contrast waste yarn cast on 150 sts. and work stockinette stitch. After knitting 6 to 8 rows, change to garment yarn and put Counter at 0. Work 10 rows Tension 3 or 4, 1 row Tension 6 or 7, 9 rows Tension 3 or 4. Knit 6 to 8 rows contrast waste yarn and remove work from machine.

# DK967



## WOMAN'S PULLOVER

SIZES: 8/10 (12)  
 YARN: Amore  
 GRAMS:  
 color 1 250 250  
 color 2 150 200  
 color 3 50 50  
 TENSION: 5 to 7 - Ribbing  $\frac{4}{4}$   
 GAUGE: 17 sts. 24 rows = 5 cm (2")  
 Ribbing: 17 sts. 30 rows "

Stockinette stitch with Intarsia Design using Short Rows or you can knit the sections using the true Intarsia method, changing the colors as shown on the Chart. Bands are K1, P1 Ribbing.

FINISHING: See General Instructions. Close shoulder seams on each side 1/4 shoulder width or as much as you need.

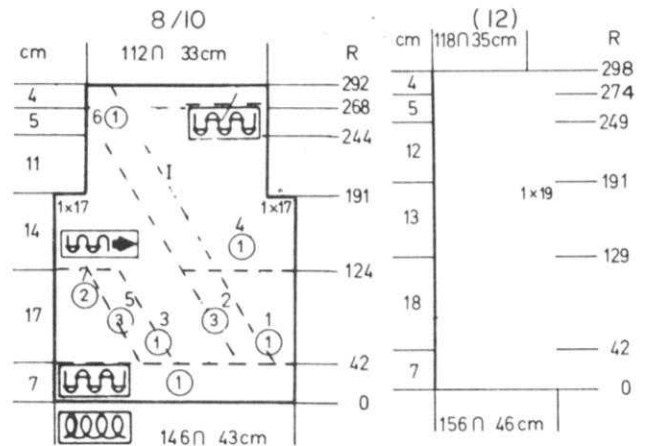

FRONT: I

NOTE: Begin the right hand side to work the Intarsia Design and change colors as shown on the Chart. Every 2nd row, move the sts. over 1 stitch. The stitches to use for the sections are as follows:  
 Beginning on the right side  
 20 - 12 - 50 - 12 - 52  
 (26 - 12 - 52 - 12 - 54)  
 Cast on 146 (156) sts. and work 42 rows Ribbing same as the back. Transfer the ribber sts. and continue in the Intarsia Design. Follow the Chart for the color changes and work one section at a time using Short Rows - or you can work with Bobbins holding the different colors and be sure to twist the yarn when changing color to prevent a hole.  
 After Row 191 SHAPE ARMHOLE same as the back and after Row 268 (274) work in Ribbing to Row 292 (298). Bind off loosely.

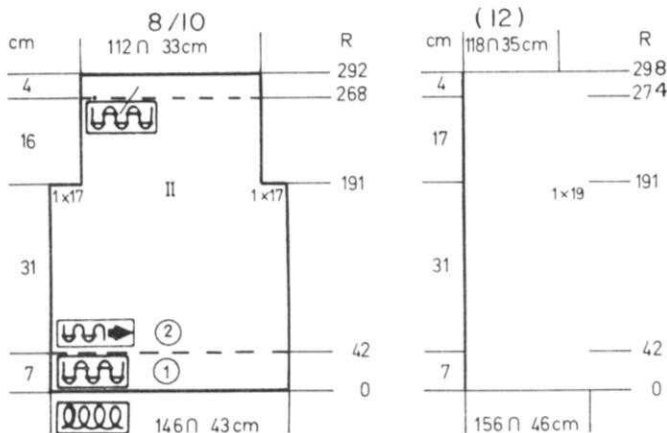

BACK: II

Cast on 146 (156) sts. with color 1 and work 42 rows Ribbing. Continue in Stockinette stitch with color 2.  
 After Row 191, SHAPE ARMHOLE: ON EACH SIDE, bind off 17 sts. then knit to Row 268 (274). Continue in Ribbing to Row 292 (298). Bind off loosely.

SLEEVES: III

Cast on 64 (72) sts. with color 1 (2nd sleeve is made with color 2) and work 48 rows Ribbing. Transfer the Ribber sts. and continue in Stockinette stitch. ON EACH SIDE, increase 1 st. every 6th row 36x for both sizes. After Row 290 (294), bind off.

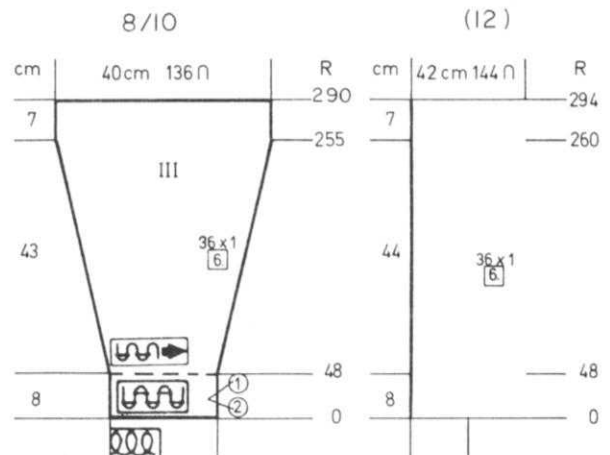



# DK968



## WOMAN'S PULLOVER

SIZES: 8/10 (12/14)  
 YARN: Any yarn to give stitch and row gauge.  
 GRAMS: APPROXIMATELY  
 color 1 200 250 -Grey Blue  
 color 2 100 100 -Navy  
 color 3 100 100 -Lt. Blue  
 color 4 40 40 -Angora  
 color 5 1 spool - Lurex  
 TENSION: 9 or 10 - Ribber 7  
 GAUGE: 15 sts. 14 rows = 5 cm (2")  
 Ribbing - 15 sts. 20 rows = 5 cm (2")

This Pullover with Cat designs as shown was made on the Electronic machine. Other machine owners can substitute any design of your choice. If you own a Computer machine and want a photostat of the original drawings, send 50¢ and a self addressed postage paid envelope.

FINISHING: See General Instructions. Embroider the 'v's above the Cats as well as all outlines and whiskers on Cats as shown in picture.

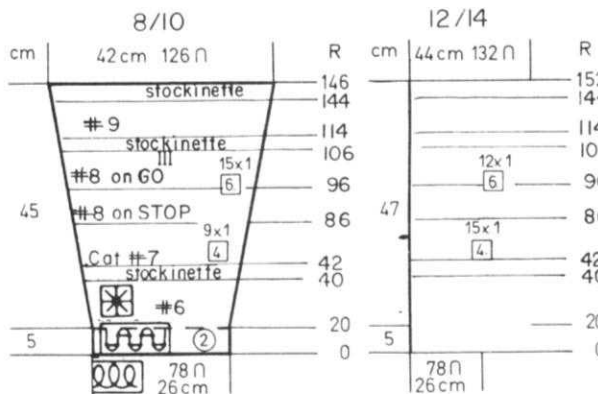

Cast on 78 sts. with color 2 and work 20 rows K2, P2 Ribbing. Continue in Pattern and AT THE SAME TIME, ON EACH SIDE, increase 1 st. every 4th row 9x (15x) every 6th row 15x (12x).  
 Work 20 rows Pattern #6.  
 2 rows Stockinette stitch.  
 42 rows Cat Pattern #7.  
 10 rows Pattern #8 - ON STOP.  
 10 rows Pattern #8 - ON GO.  
 8 rows Stockinette stitch.  
 30 rows Pattern #9.  
 Work Stockinette stitch to Row 206 then bind off.

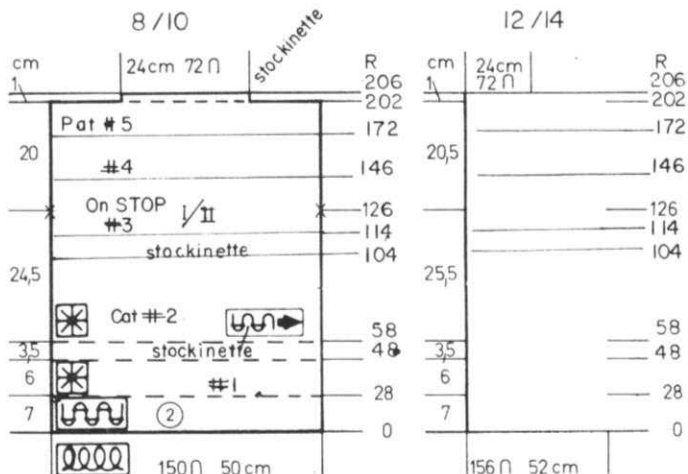

FRONT & BACK I/II Both sections the same.

Cast on 150 (156) sts. with color 2 and work 28 rows K2, P2 Ribbing. NOTE: If you want the Pullover shorter, knit less rows below and above the Cat design. Continue in Pattern #1 to Row 48. Work 10 rows Stockinette stitch (Row 58). Continue in Cat Design (Pattern #2). After Row 104, work 10 rows Stockinette stitch. Work 10 rows Pattern #3. 45 rows Pattern #4 and after Row 146, mark each side for setting in sleeve. 30 rows Pattern #5. After Row 202, ON EACH SIDE, bind off 39 (42) sts. Continue in Stockinette stitch to Row 206. Bind off.

# DK969



## WOMAN'S PULLOVER

SIZES: 10/12 (14)  
 YARN: Any yarn to give Gauge.  
 GRAMS: NO KIT AVAILABLE.  
 color 1 400 450  
 color 2 150 150  
 TENSION: 9 or 10 - 5 = Ribber  
 GAUGE: 12 sts. 14 rows = 5 cm (2")  
 12 sts. 28 rows = Ribbing "

Stockinette stitch and a Norwegian Design. Bands are K2, P2 Ribbing. Punch Your own Card.

FINISHING: See General Instructions. Make narrow hem around neckine of Pullover. TRIM: Sew head and legs to conform to shapes of pattern. Embroider the legs and toes as shown in Picture. Embroider eyes and beak in color 2. Sew beads on toes and beak. Sew pieces in place according to picture.

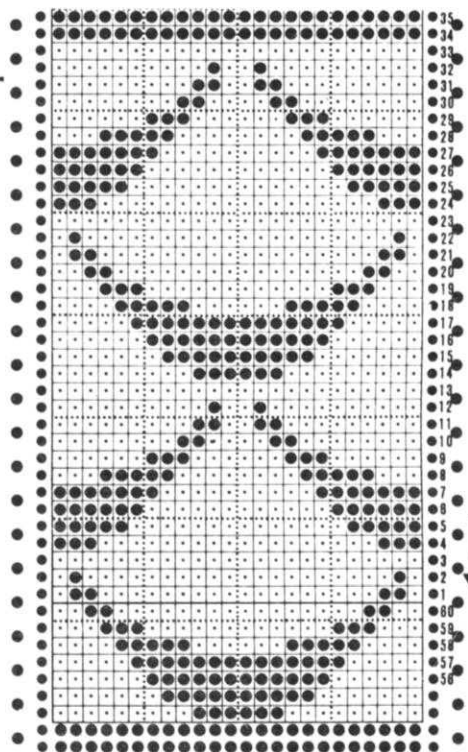

# DK969

FRONT & BACK: Two section the same I/II

Cast on 116 (120) sts. with color 1 and work 16 rows Ribbing. Continue in Stockinette stitch. Knit to Row 100 (104). Continue PATTERN. SHAPE ARMHOLE: ON EACH SIDE, bind off 3 sts. 1x, 2 sts. 2x, 1 st. 3x for both sizes. Knit to Row 154 (160). Bind off.

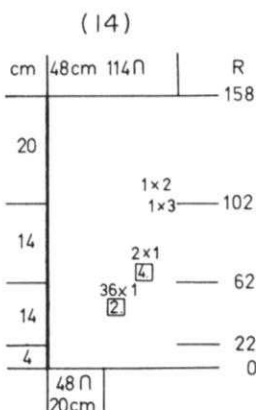
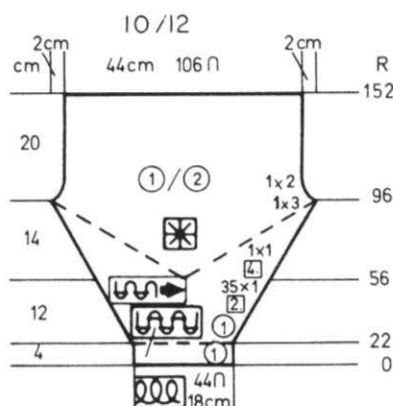
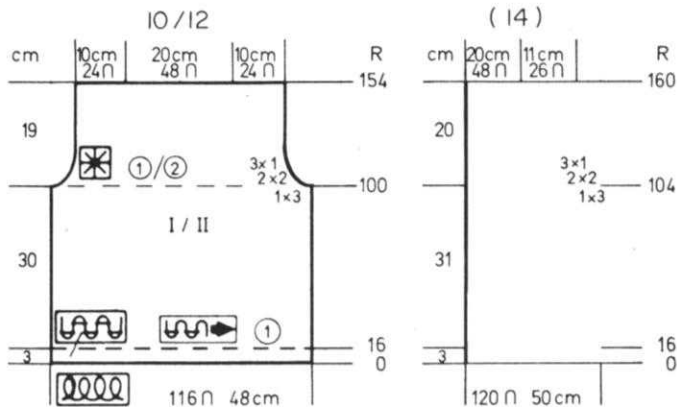

SLEEVES: III

Cast on 44 (48) sts. with color 1 and work 22 rows Ribbing. Continue in Stockinette stitch to Row 56 (62) BUT AT THE SAME TIME ON EACH SIDE, INCREASE 1 st. every 2nd row 35x (36x) AND AT THE SAME TIME, after Row 56 (62) ISOLATE THE PATTERN - 1 Pattern in center, then increase 1 pattern on each side until the whole section is in Pattern and AT THE SAME TIME ON EACH SIDE, increase 1 st. every 4th row 1x (2x). After Row 96 (102) ON EACH SIDE, bind off 3 sts. 1x, 2 sts. 1x, for both sizes. After Row 152 (158) bind off the remaining sts.

LEGS: Make 2.

Cast on 14 sts. with color 2 and work Stockinette stitch. Knit to Row 62. ON EACH SIDE, bind off 2 sts. 1x, 1 st. 5x.

TOES: Make 4.

Cast on 14 sts. with color 2 and work Stockinette stitch. After Row 4, ON EACH SIDE, bind off 2 sts. 1x, 1 st. 5x.

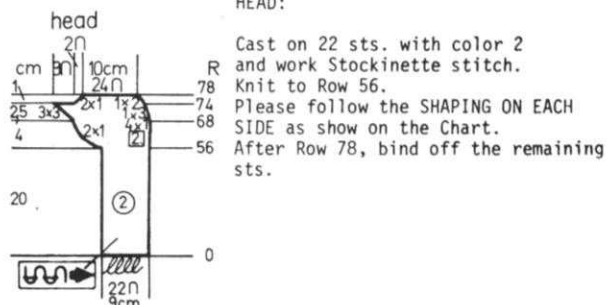
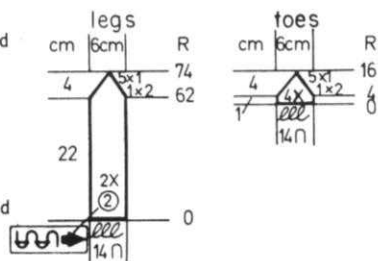

# DK970

WOMAN'S DRESS

SIZE: 8/10  
YARN: Venetia  
GRAMS: 1 Cone plus 4 extra colors (See KNITKING NEWS).  
TENSION: 4 to 6  
GAUGE: 16 sts. 24 rows = 5 cm (2")

Make up your own Intarsia Design or you can make the dress in plain Stockinette stitch.

FINISHING: See General Instructions. Turn Neckband to the inside and sew in place after sewing shoulder seam.

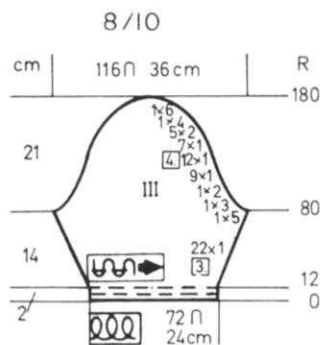

SLEEVES: III

Cast on 72 sts. with color 1 and work Stockinette stitch. Knit 12 rows with a lower tension then hang the hem. ON EACH SIDE, increase 1 st. every 3rd row 22x. After Row 80, SHAPE CAP: Please follow the bind-offs on each side as shown on the Chart. Work the 2nd sleeve in color to match design on front as shown in picture.

## DK970

**FRONT & BACK:** Two sections the same. If you work the Intarsia Design on the front section, knit the back in plain Stockinette stitch.

Cast on 166 sts. with color 1 and work 12 rows with a LOWER TENSION. Hang the hem then continue in Stockinette stitch with color 1.

Knit to Row 254.  
ON EACH SIDE, decrease 1 st. every 10th row 12 x.  
After Row 374, SHAPE ARMHOLE:  
ON EACH SIDE, bind off  
4 sts. 2x, 2 sts. 2x, 1 st. 2x.  
Knit to Row 502 and mark for hem.  
Knit to Row 514 then bind off.

Work the FRONT the same as the back inserting the Intarsia Design wherever you wish. Draw a design on graph paper and work from that.

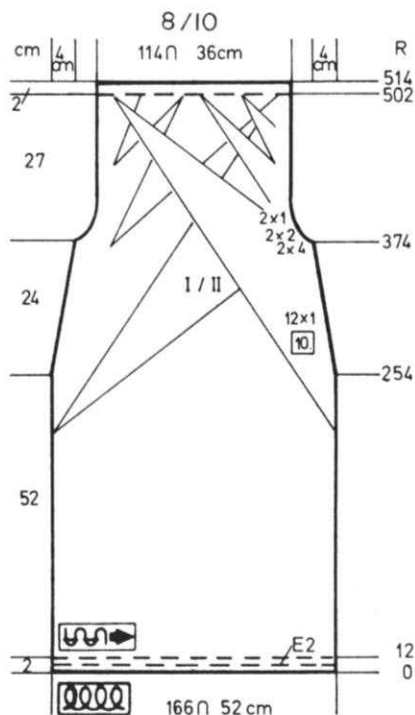

## DK971

### WOMAN'S TWO PIECE DRESS

**SIZES:** 10/12  
**YARN:** Any fine yarn to give gauge.  
**GRAMS:** 750 grams total weight.  
color 1 = Black (See KNITTING NEWS)  
color 2 = White  
color 3 = Violet  
color 4 = Orange  
color 5 = Blue  
**TENSION:** 2 to 4  
**GAUGE:** 16 sts. 24 rows = 5 cm (2")



Stockinette stitch with Short Rows and changes in color are used for the skirt and front of Top. Lower the Tension for all bands.

**FINISHING:** TOP: Sews side seams and set in sleeves. Fold neckband to the inside (half) and sew shoulder seams on each side, leaving the neck open for as wide as you wish.  
SKIRT: Weave or slip stitch the open sts. together and remove waste yarn. You can also hang the sts. back onto the machine and bind them off together if you prefer. Finish waistband and pull elastic through casing. Make hem at lower edge.

### WAISTBAND:

Divide the skirt in half then with wrong side facing you, pick up half the waist - 120 to 128 sts. Add 1 extra stitch on each side for sewing bands together. With black and using a lower tension knit 26 rows stockinette stitch. Hang the hem and bind off. REPEAT for other half of waist.

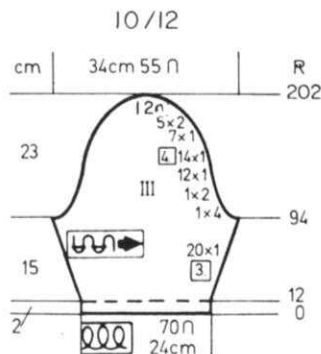

### 10/12

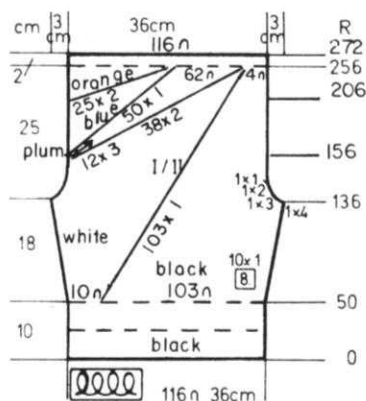

### FRONT:

Work the front the same as the back but WORK SHORT ROWS FOR THE DESIGN, following the CHART for the color changes and short Rows.

### BACK: II

Cast on 116 sts. with color 1 (black) and with lower tension, knit 50 rows then hang the hem. Change to garment tension. ON EACH SIDE, increase 1 st. every 8th row 10x.  
After Row 136, SHAPE ARMHOLE:  
ON EACH SIDE, bind off  
4 sts. 1x, 3 sts. 1x, 2 sts. 1x, 1 st. 1x.  
Knit to Row 256 then change to lower tension and with White (color 2) knit to Row 272 Bind off loosely.

### SLEEVES: III One White, one Black.

Cast on 70 st. with Orange and work with lower tension to Row 12. Hang the hem, and continue with Black (White).  
ON EACH SIDE, increase 1 st. every 3rd row 20x.  
After Row 94, SHAPE CAP.  
ON EACH SIDE, bind off  
4 sts. 1x, 2 sts. 1x, 1 st. 12x, then every 4th row 1 st. 14x, every 2nd row 1 st. 7x, 2 sts. 5x. Bind off 12 sts.  
Work the second sleeve with Black for band and white for sleeve.

## DK971

SKIRT: Begin and end with Waste yarn.

Cast on 200 sts. with waste yarn and after knitting 13 rows, knit 1 row with Ravel Cord to the right side. \*COUNTER AT 0.

With BLACK, work 36 rows over all needles then work SHORT ROWS.

Put into holding position  
2 sts. 20x Black (color 1)  
2 sts. 5x Orange (color 4)  
2 sts. 30x Black (color 1)  
2 sts. 26x Blue (color 5)

Bring all the needles into working position and work

24 rows Black (color 1)  
10 rows Blue (color 5)

Carriage on the right - Row Counter at 232. Change to WHITE YARN. (color 2)

Put all but 38 sts. on the right into HOLDING position, knit 2 rows over the 38 sts. then Bring back into working position

2 sts. 30x White (color 2)  
2 sts. 21x Black (color 1)  
2 sts. 30x White (color 2)  
ALL NEEDLES IN WORK and with White, (color 2) knit 36 rows. - Row Counter 432.

SHORT ROWS. Put into holding position

2 sts. 10x White (color 2)  
2 sts. 5x Black (color 1)  
2 sts. 30x White (color 2)  
2 sts. 3 6x Orange (color 4)

ALL NEEDLES IN WORK, and knit 10 rows with Orange (color 4). Row Counter 604.

Put all but 38 needles on the right into holding position, with Blue, knit 2 rows over the 38 needles then bring back into working position,

2 sts. 49x Blue (color 5)  
2 sts. 23x Black (color 1)

ALL NEEDLES IN WORK and with White knit 36 rows. Row Counter 786.  
SHORT ROWS. Put into holding position

2 sts. 36x Black (color 1)  
2 sts. 45x Orange (color 4)

ALL NEEDLES IN WORK, knit 24 rows White (color 2)

10 rows Black (color 1).

Row Counter 982. Put all but 38 needles on the right into HOLDING position, with Black, knit 2 rows over the 38 needles then bring back into working position

2 sts. 31x Black (color 1)  
2 sts. 5x Orange (color 4)  
2 sts. 45x White (color 2).

Counter should say 146 - you have actually knitted 1146 rows. One half the skirt is completed... Go back and REPEAT for 2nd half.

## DK972



### WOMAN'S DRESS

SIZE: 8/10  
YARN: Fine yarn such as 2/24 or any yarn that will give gauge.

GRAMS:  
color 1 350  
color 2 350

TENSION: Top = Tension 2 for color 1  
Tension 0 for color 2  
Skirt = Tension 2 for color 1  
Tension 1 for color 2

GAUGE:  
Top - 15 1/2 sts. 32 rows = 5 cm (2")  
Skirt - 15 sts. 29 rows = 5 cm (2")

NO KIT AVAILABLE

Changes in Tensions plus Short Rows are used for knitting this garment.

FINISHING: Weave the open sts. of the skirt together or you can hang the stitches of both sections onto machine and bind them off after removing the waste yarn. Sew sides of top section approximately 21 cm (check your own measurements for arm opening).

Attach top sections to skirt. Sew shoulders and turn in neck opening and sew in place. Make hem in skirt. Make belt carriers 5 cm long and attach to sides. Make Belt - 3 strips of 5 sts and knit for as long as you wish in Stockinette stitch. Braid the 3 strips together (See picture) and pull through belt carriers on sides of dress.

SIDE BANDS: Make 4.

Cast on 138 sts. with color 1 and work Stockinette stitch with tension 2. Hang the hem then hang one side of top onto same needles and bind off. REPEAT for 3 other sides of top.

TOP SECTION: Make 2 the same.

Cast on 130 sts. with color 1 and with tension 1, knit 2 rows. Put Counter at 0.

\*WORK SHORT ROWS ON EACH SIDE.  
1 st. 6x. Bring all needles into working position beginning next 2 rows. (Row 14).

Change to color 2 and TENSION 0. WORK SHORT ROWS ON EACH SIDE.  
1 st. 4x. Bring all needles into working position beginning next 2 rows. (Row 24).

Change to color 1 and TENSION 1. REPEAT FROM \* until there are 18 sections in color 1 and 17 sections in color 2. Be sure to read PRACTICAL KNITTING HINTS THIS ISSUE. Bind off.

8 / 10

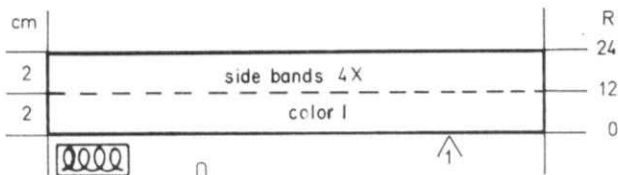
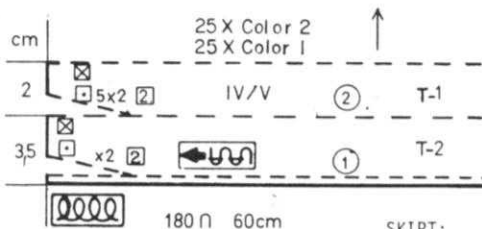

SKIRT:

USE OPEN CAST ON WITH WASTE YARN. Cast on 180 sts. After Knitting 10 or 12 rows, change to color 1 and put Counter at 0. \*TENSION 2 - color 1. Work SHORT ROWS: ON OPPOSITE SIDE OF SLIDE put into holding position 2 sts. 9x. Bring all the needles into working position and knit 2 rows. (Row 20) TENSION 1 - Color 2. Work SHORT ROWS: ON OPPOSITE SIDE OF SLIDE put into holding position 2 sts. 5x. Bring all the needles into working position and knit 2 rows. (Row 32). REPEAT FROM \* until there are 25 sections color 1 and 25 sections color 2. Remove the sts. onto contrast waste yarn. Weave the open sts. together or you can hang the sts. back onto the machine and bind them off together.

8 / 10

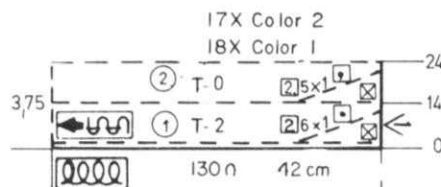

# DK973



## WOMAN'S DRESS

SIZE: 8/10  
 YARN: Any fine two-ply yarn to give gauge.  
 GRAMS:  
 color 1 300  
 color 2 200  
 TENSION: 3 or 4  
 GAUGE: 15 1/2 sts. 27 1/2 rows = 5 cm (2")

The Skirt and sleeves are knitted using Short Rows with changes in color. Work in Stockinette stitch.

**FINISHING:** Close side seams and shoulders of top. Work 2 rows single crochet around neckline tightly. Make loop of 12 chains on right side for buttonhole. Make narrow hem to the inside of sleeves. Sew in sleeves. Attach one half circle to each side of bodice. Join top to Skirt. Crochet 2 belt carriers to sides (5 cm). Pull belt through carriers.  
**SKIRT:** Press, then weave the open sts. together and remove the waste yarn.

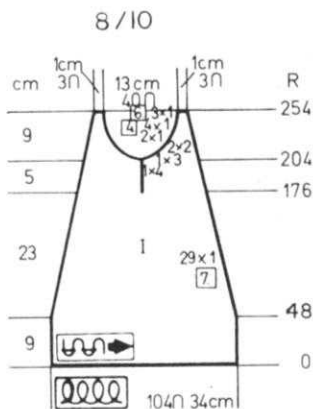

### TOP FRONT: I

Cast on 104 sts. with color 1 and work Stockinette stitch. After Row 48, ON EACH SIDE, decrease 1 st. every 7th row 29x. AT THE SAME TIME, after Row 176, divide in the center. Put the needles on the left into holding position and complete the right side first.  
 \*ON NECK SIDE, bind off 4 sts. 1x, 3 sts. 1x, 2 sts. 2x, 1 st. 2x, then every 4th row decrease 1 st. 4x, and every 6th row decrease 1 st. 3x. After Row 254, bind off the remaining 3 sts. Bring the needles on the left into working position, knit 1 row to the left side, turn the Row Counter back to 176 and complete the left half. Follow the instructions from \* and don't forget the side shaping.

### 8/10

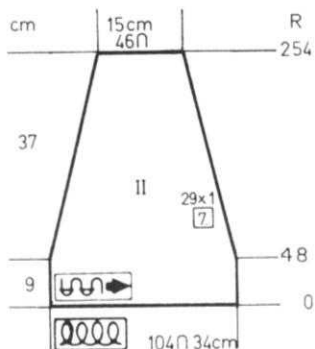

### TOP BACK: II

Cast on 104 sts. with color 1 and work Stockinette stitch. After Row 48, ON EACH SIDE, decrease 1 st. every 7th row 29x. After Row 254, bind off the remaining sts.

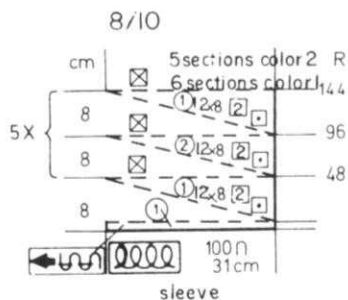

### SLEEVES:

Cast on 100 sts. with color 1 and knit 2 rows then work SHORT ROWS: Counter at 0.  
 \*ON OPPOSITE SIDE OF SLIDE, put into holding position 8 sts. 12 x. ON OPPOSITE OF SLIDE, bring back into working position 8 sts. 12x.\*\*  
 CHANGE TO COLOR 2 and REPEAT the SHORT ROWS from \* to \*\*. CHANGE TO COLOR 1.  
 Continue to work the Short Rows changing color each time a wedge is completed until there are 6 sections color 1 and 5 sections of color 2. Bind off.

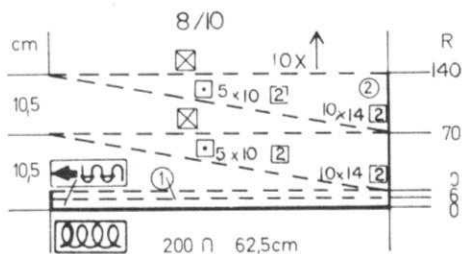

### SKIRT:

NOTE: If you need a waist measurement larger than 24", add 2 panels - one of each color.

With contrast waste yarn, cast on 200 sts. After knitting 10 to 12 rows, change to color 1. One Panel is 70 rows and to begin you will knit only half or part of a panel and will complete it at the other end. This will make it easier for you to weave the seam. With color 1, knit 6 rows. Begin the SHORT ROWS. Bring all the needles into holding position except for the 10 last needles on the right side. Knit 2 rows. Bring back into working position

14 sts. 10x, then 10 sts. 5x. (half section completed). PUT COUNTER AT 0 and begin the full panels. COLOR 2 - \*ON OPPOSITE SIDE OF SLIDE, put into holding position 10 sts. 5x, 14 sts. 10x. Put ALL NEEDLES INTO WORKING POSITION and knit 10 rows. BRING ALL THE NEEDLES INTO HOLDING position except for the last 10 needles on the right side. Knit 2 rows. Bring back into working position, 14 sts. 10x, then 10 sts. 5x. (One full section completed)\*\*.  
 Change to COLOR 1 and REPEAT from \* to \*\* until there are 14 sections of each color (the last section will be the first half of the short rows plus 4 rows over all needles). Remove the sts. onto contrast waste yarn.

# DK974

## WOMAN'S DRESS

SIZE 10/12  
 YARN: Linena (See KNITTING NEWS).  
 GRAMS: 1 Cone  
 TENSION: 2 to 3  
 GAUGE: 14 sts. 35 rows = 5 cm (2")  
 In Tuck Pattern



A Tuck stitch Pattern. Punch your own Card. Worn on Purl side.

FINISHING: See General Instructions. Make a Cord for Belt over 5 sts. Put bead on each end and tie (See Picture). Make belt carriers on sides of dress and pull cord through. Hem lower edge of dress. Work 5 rows single crochet around neckline (or you can pick up the neck sts. of front then back and work 20 rows Stockinette stitch then hang hem). Make hem at wrist and pull elastic through.

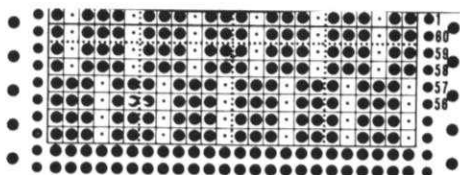

REPEAT PUNCH CARD THROUGH ROW 41 then punch 2 rows of holes for connecting card.

## FRONT: I

Work the front the same as the back to Row 744. Put half the sts. on the left into holding position and complete the right side first.  
 \*ON NECK SIDE, bind off 13 sts. 1x, 3 sts. 2x, 2 sts. 4x, 1 st. 4x and after Row 780, SHAPE SHOULDER same as the back. Bring the needles on the left into working position, knit 1 row in Pattern to the left side, turn the Row Counter back to 744 and complete the left half. Follow the instructions from \*.

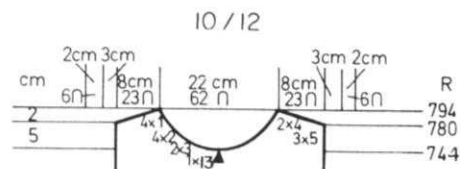
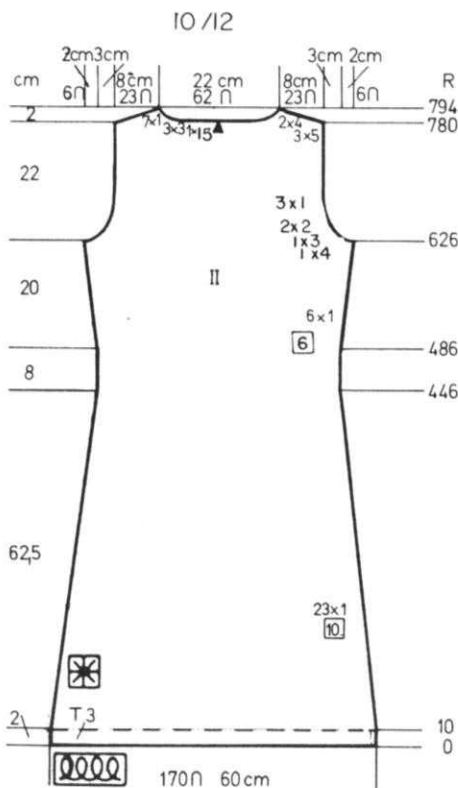

## BACK: II

Cast on 170 sts. and work in Pattern. After Row 10, ON EACH SIDE, decrease 1 st. every 10th row 29x. After Row 486, ON EACH SIDE, increase 1 st. every 6th row 6x. Knit to Row 626. SHAPE ARMHOLE: ON EACH SIDE, bind off 4 sts 1x, 3 sts. 1x, 2 sts. 2x, 1 st. 3x. After Row 780, put half the sts. on the left into holding position and complete the right side first. \*SHAPE SHOULDER AND NECK AT THE SAME TIME. FOR SHOULDER, bind off 5 sts. 3x, 4 sts. 2x and FOR NECK, bind off 15 sts. 1x, 3 sts. 3x, 1 st. 7x. Bring the needles on the left into working position, knit 1 row to the left side in Pattern, turn the Row Counter back to 780 and complete the left half. Follow the instructions from \*.

## SLEEVES: III

Cast on 120 sts. and work in Pattern. Knit to Row 314. SHAPE CAP: ON EACH SIDE, bind off 4 sts. 1x, 3 sts. 1x, 2 sts. 2x, 1 st. 25x, 2 sts. 2x, 3 sts. 2x, 4 sts. 1x, then bind off the the remaining sts.

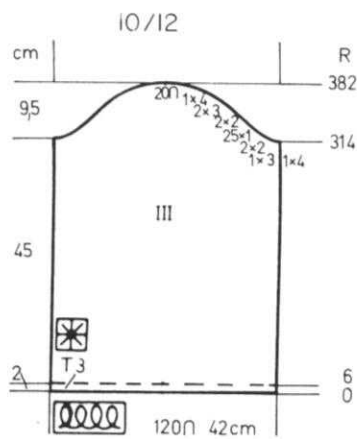

# DK975

## WOMAN'S BEDJACKET

SIZE Medium  
 YARN: Micaela  
 GRAMS: 300  
 TENSION: 4 to 6  $\frac{3}{3}$  = Ribber  
 GAUGE: 13 sts. 30 rows = 5 cm (2")  
 in Pattern.  
 22 sts. 29 rows = 5 cm (2")  
 in Ribbing.



FINISHING: See General Instructions. Remove contrast yarn. Join back of neckband. Turn band toward the inside and sew in place. Attach button loops to the right side and sew on 8 buttons. (See Picture).

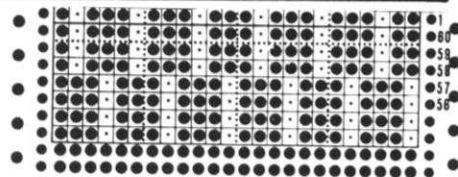

REPEAT PUNCH CARD THROUGH ROW 41 then punch 2 rows of holes for connecting card.

# DK975

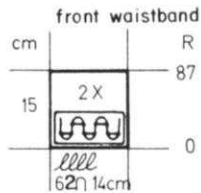

FRONT WAISTBAND: Make 2.

Cast on 62 sts. and work K1, P1 Ribbing to Row 87. Transfer the ribber sts. to main machine then hang one front to these needles and knit 1 row then bind off.

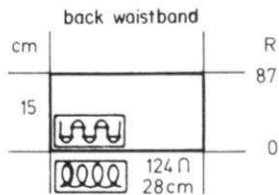

BACK WAISTBAND:

Cast on 124 sts. and work the same as front waistband. After Row 87, hang the sts. of the back (transfer ribber sts. first) to these needles, knit 1 row then bind off.

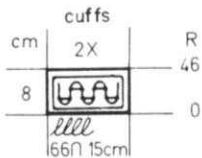

CUFFS: Make 2.

Cast on 66 sts. and work 46 rows K1, P1 Ribbing. Transfer Rib Sts. Hang edge of sleeve onto these needles, knit 1 row and bind off loosely. Repeat for other sleeve.

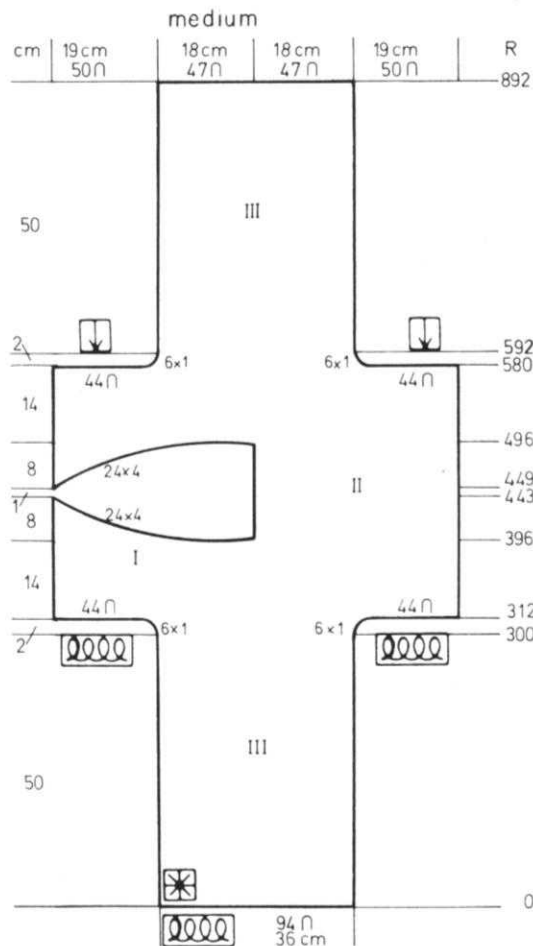

FRONT & BACK AND SLEEVES (knitted in one piece).

Cast on 94 sts. and work in Pattern.  
 Knit to Row 300. ON EACH SIDE on every 2nd row cast on 1 st. 6x.  
 After Row 312, ON EACH SIDE, cast on 44 sts.  
 Knit to Row 396.  
 Put 97 sts. on the left into holding position and knit over the right 97 sts. to Row 496. Put these needles into holding position.  
 Put Row Counter back to 396 and work the front.  
 Bring 4 sts. back into working position 24x (increases).  
 Bind off remaining st.  
 Cast on 1 st. on needle 97 then increase 4 sts. 24x.  
 Counter at 496 -Bring all needles into working position and knit to Row 580.  
 ON EACH SIDE, bind off 44 sts. ON EACH SIDE, decrease 1 st. 6x.  
 Continue in Pattern to Row 892. Bind off.

FRONT AND NECK BANDS:

With contrast waste yarn, cast on 160 sts. and work Stockinette stitch. After knitting 8 to 10 rows, change to garment yarn and put counter at 0. Knit 6 rows, 1 row with larger tension, then knit to row 12. With purl side facing you hang 1 front to center back neck onto these needles and knit 1 row. Bind off. REPEAT for 2nd half.

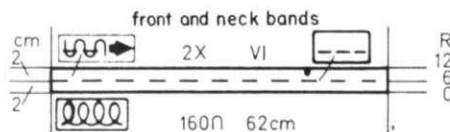

# DK976



WOMAN'S PULLOVER

SIZE: 12/14  
 YARN: Vienna  
 GRAMS: color 1 250, color 2 100, color 3 100, 4 = Ribber  
 TENSION: 6 to 8 4 = Ribber  
 GAUGE: 13 1/2 sts. 22 rows = 5 cm (2") in Pattern.

A Tuck stitch Pattern. Punch your own Card. Bands are K2, P2 Ribbing.

FINISHING: See General Instructions. To finishing Neckline, put neck edge inside tubular band and weave the outside, then inside edge of band. Close neckband sides & sleeve band seams.

\*4 ROWS Color 1  
 4 ROWS Color 2  
 4 ROWS Color 3  
 REPEAT FROM \*.

REPEAT PUNCH CARD THROUGH ROW 41 then punch 2 rows of holes for connecting Card.

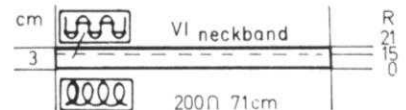
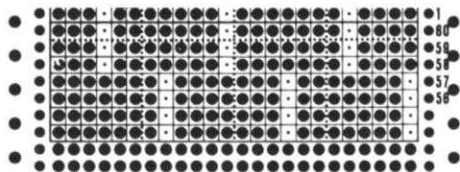

NECKBAND: Color 1.

Cast on 200 sts. and work 15 rows K2, P2 Ribbing then work 6 rows TUBULAR. Remove onto contrast waste yarn.

# DK976

FRONT: I

Cast on 42 sts. with color 1 and work Stockinette stitch to Row 4 then continue in Pattern.

After Row 5, increase 1 st. then every 4th row increase 1 st. 28x in all.

After Row 123, cast on 2 sts. 2x, 4 sts. 5x, 6 sts. 2x, 8 sts. 3x.

After Row 206, ON NECK EDGE bind off

3 sts. every 2nd row 3x, 2 sts. 4x, 1 st. 7x, then every 4th row 1 st. 6x.

Mark each edge after Row 255 for center, then increase 1 st. every 4th row 6x, then every 2nd row 7x, 2 sts. 4x, 3 sts. 3x.

After Row 347, Bind off 8 sts 3x, 6 sts. 2x, 4 sts. 5x, 2 sts. 2x, then on every 4th row decrease 1 st. 28x.

After Row 507, continue in Stockinette stitch to Row 512 then bind off.

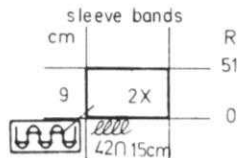

SLEEVE BANDS: Color 1.

Join shoulders first, then cast on 42 sts. and work in K2, P2 Ribbing to Row 51. Transfer the ribber sts. to main machine, Hang edge of sleeve onto needles and knit 1 row, then bind off loosely. Make 2nd sleeve band the same.

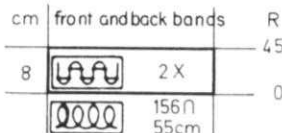
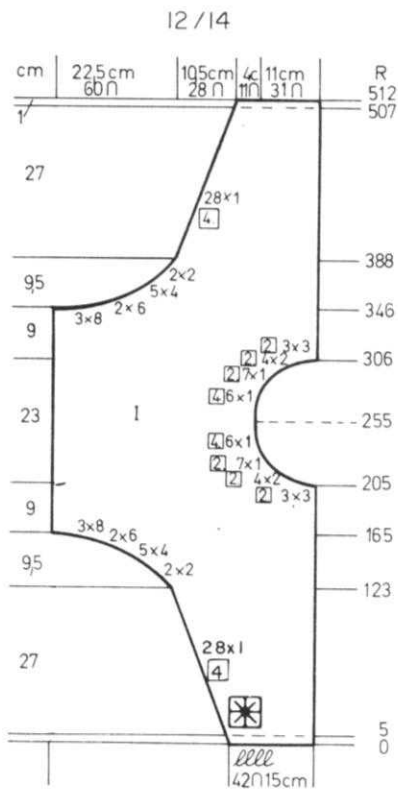

FRONT & BACK BANDS: Color 1.

Cast on 156 sts. and work 45 rows K2, P2 Ribbing. Transfer the Ribber sts. to main machine then hang bottom of front onto needles. Knit 1 row then bind off loosely. Repeat for back band.

12/14

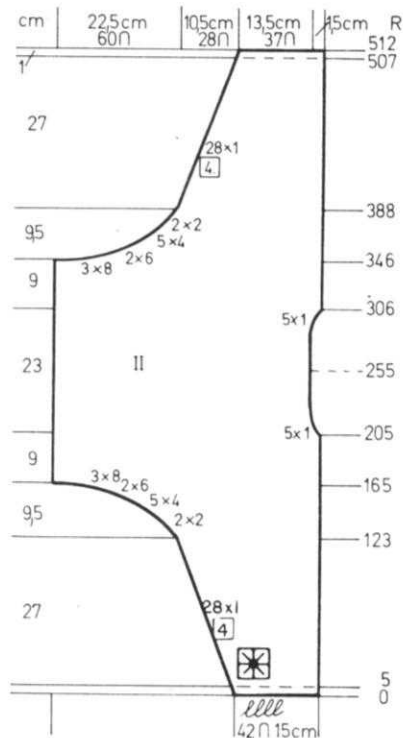

BACK: II

Work the back the same as the front except for the NECK SHAPING. After Row 205, ON NECK EDGE, decrease 1 st. every 2nd row 5x. Mark Row 255 as you did for FRONT. After Row 296, ON NECK EDGE, increase 1 st. every 2nd row 5x. After Row 347, Bind off same as you did for front.

# DK977

WOMAN'S JACKET & SKIRT

SIZE: 8/10

YARN: Fine two-ply yarn or any yarn to give gauge. NO KIT AVAILABLE.

GRAMS: color 1 Approx. 1 1/2 lbs.  
color 2 Approx. 1 1/2 lbs.

TENSION: Skirt = 8 or 9 with double yarn.  $\frac{2}{2}$  = Rib - 4 = Pattern

GAUGE: Skirt: 13 1/2 st. 23 rows = 5 cm (2")  
Jacket - Pattern 15 1/2 sts. 32 rows = 5 cm (2")  
1x1 Rib = 16 sts. 36 rows = 5 cm (2")

The Skirt is stockinette stitch using doubled yarn and is made with Short Rows. The Jacket is a Ribbing Pattern stitch - Punch your own Card. The same number of needles are used on both needle beds. Bands and Collar and full needle 1 x 1 Rib.



FINISHING: See General Instructions. Skirt. Weave the open sts. together and remove waste yarn. Make hem at waist and pull elastic through casing. Jacket: Sew Collar and bands in place.

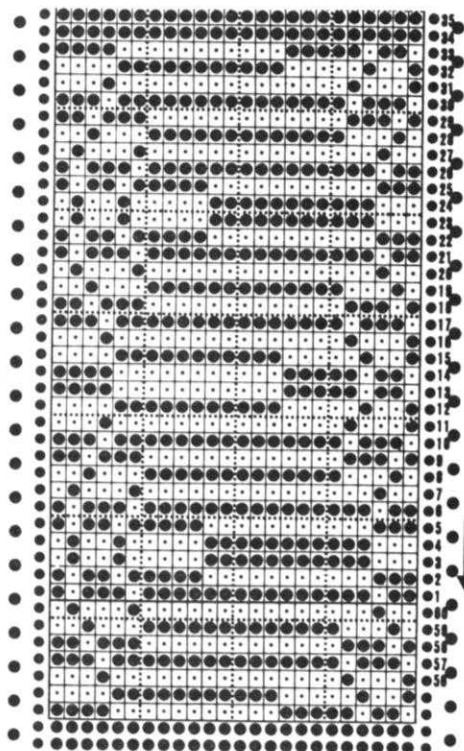



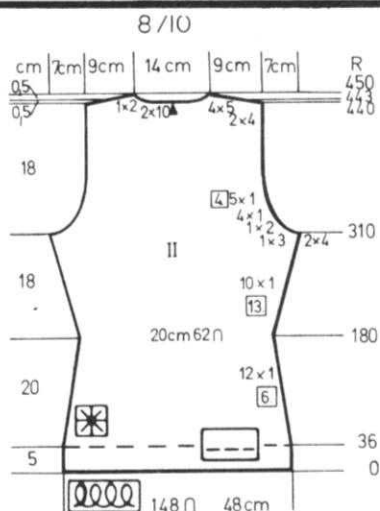

BACK: II

Cast on 148 sts. (both needle beds) with color 2 and work in Ribbing to Row 36. Continue in Pattern. ON EACH SIDE, decrease 1 st. every 6th row 12x. After Row 180, ON EACH SIDE, increase 1 st. every 13th row 10x. After Row 310, SHAPE ARMHOLE: ON EACH SIDE bind off 4 sts. 2x, 3 sts. 1x, 2 sts. 1x, 1 st. 4x, then every 4th row 1 st. 5x. After Row 440, SHAPE SHOULDER and watch for NECK SHAPING. FOR SHOULDER, bind off 4 sts. 2x, 5 sts. 4x. FOR NECK: After Row 442, put half the sts. on the left into holding position and complete the right side first. \*ON NECK SIDE, bind off 10 sts. 1x, 2 sts. 1x. Bring the needles on the left into working position, knit 1 row in Pattern to the left side, turn the Row Counter back to 442 and complete the left half. Follow the instructions from \* and don't forget to complete the shoulder shaping.

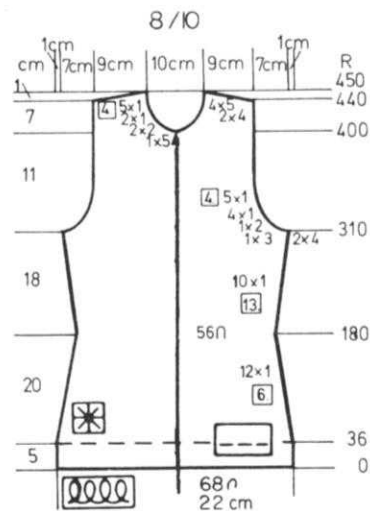

FRONT: I Make 1, reverse 1.

Cast on 68 sts. same as back and work in 1 x 1 ribbing to Row 36. Continue in Pattern. ON THE RIGHT (left for 2nd section), decrease 1 st. every 6th row 12x. After Row 180, on side edge increase 1 st. every 13th row 10x. After Row 310, SHAPE ARMHOLE same as the back then knit to Row 400. ON NECK SIDE bind off 5 sts. 1x, 2 sts. 2x, 1 st. 2x, 1 st. every 4th row 5x AND AT THE SAME TIME- after Row 440, SHAPE SHOULDER same as the back.

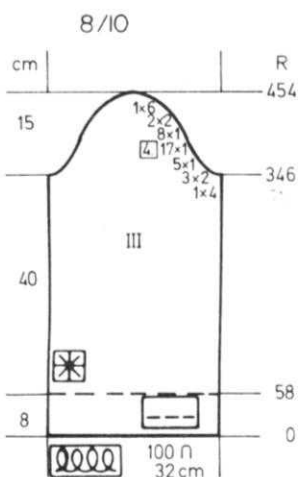

SLEEVES: III

Cast on 100 sts. (full needle rib) with color 2 and work in Ribbing to Row 58. Continue in Pattern. Knit to Row 346. SHAPE CAP: ON EACH SIDE, bind off 4 sts. 1x, 2 sts. 3x, 1 st. 5x, 1 st. every 4th row 17x, 1 st. 8x, 2 sts. 2x, 6 sts. 1x.

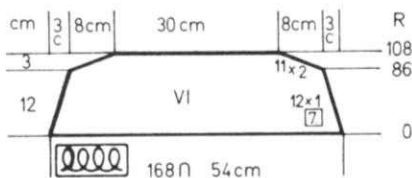

COLLAR: VI

Cast on 168 sts. with color 2 and work in Full Needle 1 x 1 Ribbing. ON EACH SIDE, decrease 1 st. every 7th row 12x then ON EACH SIDE after Row 86, bind off 2 sts. 11x. After Row 108, bind off the remaining sts.

BELT:

Cast on 16 sts. with color 2 and work in Full Needle 1 x 1 Ribbing to Row 432. Bind off.

SKIRT:

OPEN CAST ON WITH CONTRAST WASTE YARN. Cast on 200 sts. and work Stockinette stitch. After knitting 9 to 11 rows, work 1 row with ravel cord then continue with DOUBLED garment yarn - color 1. Put Counter at 0. \*Knit 40 rows then work SHORT ROWS. ON OPPOSITE SIDE OF SLIDE, put into holding position 12 sts. 15x. ON OPPOSITE SIDE OF SLIDE, bring back into working position, 12 sts. 15x. All needles in working position, REPEAT from \* until there are 10 sections in all. Remove onto contrast waste yarn.

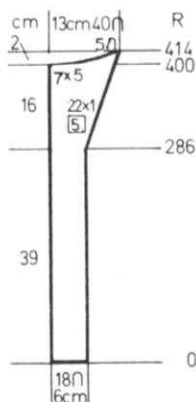

FRONT BAND: Make 1, reverse 1.

Cast on 18 sts. (full needle Rib) with color 2 and work in Ribbing. After Row 286, on the RIGHT (left for 2nd section), increase 1 st. every 5th row 22x and after Row 401 Bind off 5 sts. 7x. then bind off the remaining sts.

# DK978

## WOMAN'S PULLOVER

SIZES: 8/10 (12)

### YARN:

Color 1 = Venetia  
Color 2 = Micaela  
Color 3 = Capriccio

### GRAMS:

color 1 300 350  
color 2 100 100  
color 3 1 Ball for both sizes.

TENSION: 5 or 6 Rib 4 or 5

GAUGE: 14 sts. 20 rows = 5 cm (2")

Rib: 16 sts. 22 rows = 5 cm (2")

Made on the Compuknit Machine. If you own an Electronic machine and want a photostat of the original drawings, send 50¢ and a self addressed postage paid envelope. Mock Ribbing is used for the waist and sleeve bands.

FINISHING: See General Instructions. Fold neckband to the inside and sew in place. For eyes, sew on 2 glass beads.

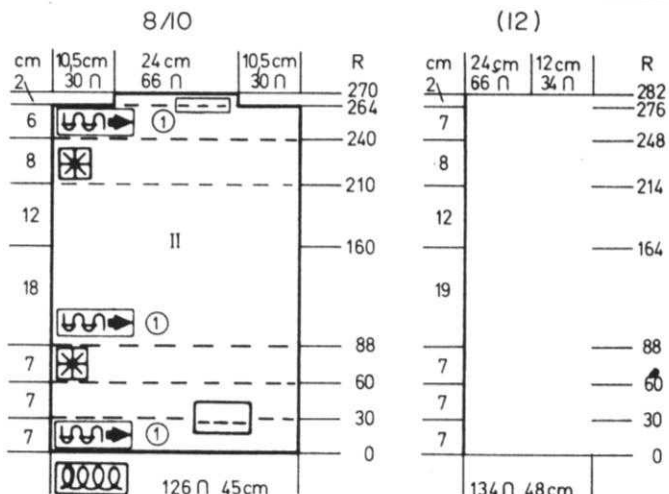

BACK: II

Bring 126 (134) needles into working position then push back to the out of work position, every 2nd needle. With contrast waste yarn, cast on over the remaining sts. in work. After knitting 8 to 10 rows, change to garment yarn - color 1 and work stockinette stitch to Row 60. Pick up the first row of main knitting and hang the sts. onto empty needles (hem). Continue over all needles. Work 28 rows Norwegian Design - 12 rows colors 1 & 2 8 rows colors 1 & 3 8 rows colors 1 & 2 Continue in Stockinette stitch with color 1 to Row 210 (214). REPEAT the same Norwegian Design as before then continue in Stockinette stitch with color 1 to Row 264 (276). ON EACH SIDE, bind off 30 (34) sts. then knit to Row 270 (282). Bind off loosely.

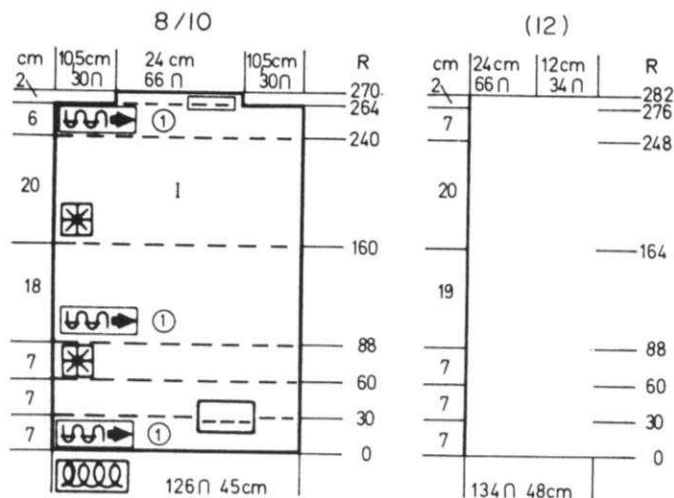

FRONT: I

Work the front the same as the back to Row 160 (164) then work the Tiger Head Design to Row 240 (248). Complete the front the same as the back.

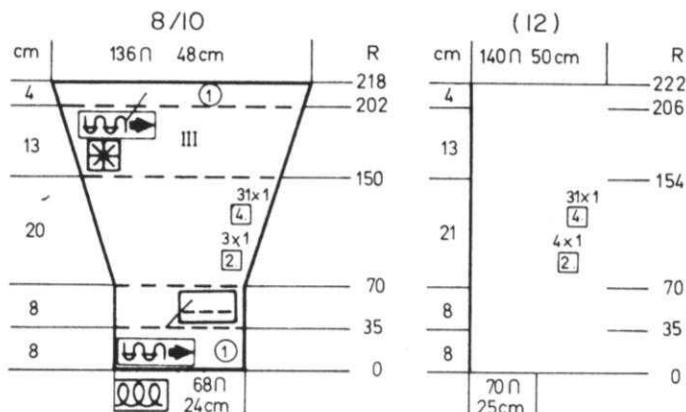

SLEEVES: III

Bring 68 (70) needles into working position and set up for Mock Ribbing by pushing every other needle back to the out of work position. Cast on with waste yarn over the remaining needles and work the Mock Ribbing same as you did for back and front. After Row 70, bring all needles into working position and hang the hem as you did before. Continue working over all needles. ON EACH SIDE, increase 1 st. every 2nd row 3x (4x) then every 4th row 1 st. 31x. After Row 150 (154). Work the Norwegian Design to Row 202 (206) then continue with Stockinette stitch and color 1 to Row 218 (222). Bind off.

# DK979



## WOMAN'S PULLOVER

SIZES: 8 (10)  
 YARN: Crocus  
 GRAMS:  
 color 1 250 250  
 color 2 50 50  
 color 3 50 50 4  
 TENSION: 6 to 8 Ribbing 7  
 GAUGE: 15 sts. 19 rows = 5 cm (2")

NOTE: We have not included the instructions for the Intarsia. Use any Design or stripes of your choice. Knitted sideways on the machine in Stockinette stitch. All Bands are K1, P1 Ribbing.

FINISHING: See General Instructions.

## BACK: II

To the extreme right of machine cast on 63 sts. with color 1 and work 20 rows K1, P1 Ribbing. Continue in Stockinette stitch. After Row 71, cast on 2 sts. 5x then cast on 105 (111) sts. After Row 138 (146), SHAPE NECK: Decrease 1 st. every 2nd row 3x. After row 166 (174), mark for center of garment then work in REVERSE. (10)

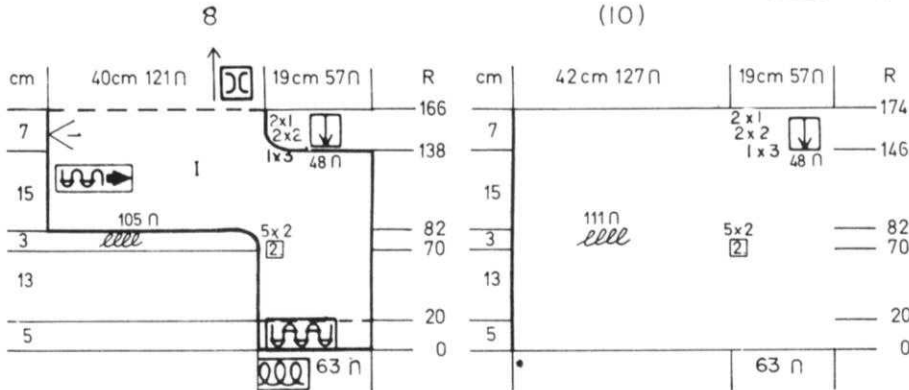
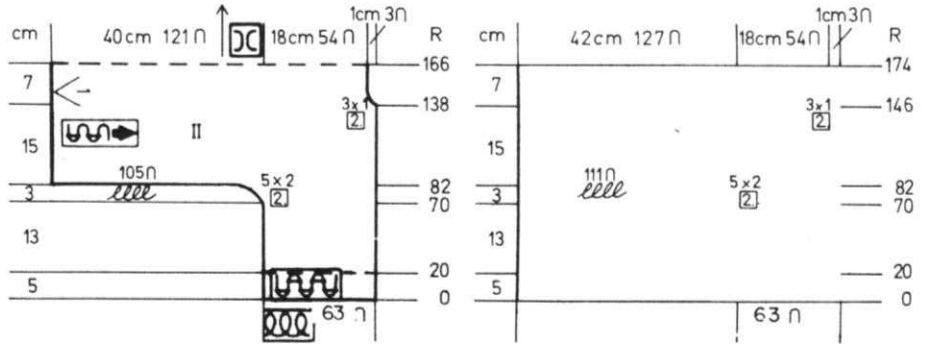

## FRONT: I

Work the front the same as the back EXCEPT FOR THE NECK SHAPING. After Row 138 (146), bind off 48 sts. then bind off 3 sts. 1x, 2 sts. 2x, 1 st. 2x for both sizes. After Row 166 (174) mark for center of garment then work in REVERSE.

## LOWER BANDS: Make 2.

Cast on 130 sts. and work 20 rows Ribbing. Bind off or remove onto waste yarn - or if you prefer, you can pick up the sts. on lower edge then work the Ribbing.

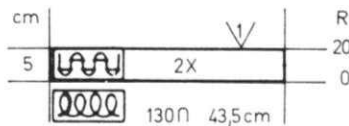

NECKBAND: Pick up the sts. around neck after sewing up one shoulder then work 20 rows Ribbing. Bind off.

# DK980

## WOMAN'S PULLOVER

SIZES: 10 (12) [14/16]  
 YARN: Nomotta Viola  
 (See KNITTING NEWS).  
 GRAMS:  
 color 1 250 300 350  
 color 2 200 250 300  
 TENSION: 8 or 9  
 GAUGE: 12 sts. 19 rows = 5 cm (2")



Stockinette stitch with Intarsia on front and back sections. Bands are K1, P1 Ribbing.

FINISHING: See General Instructions. Work 2 rows single crochet around neckline.

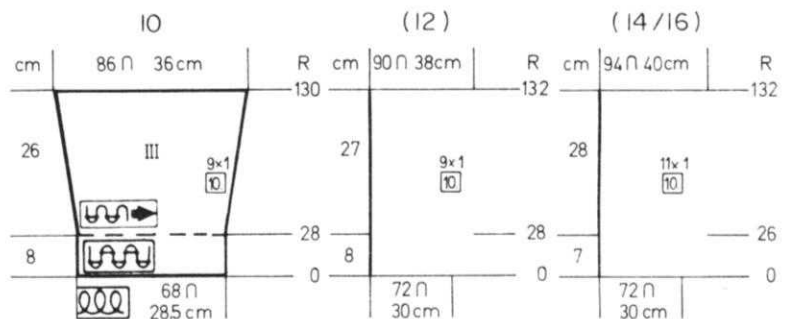

## SLEEVES: III

Cast on 68 (72) [72] sts. with color 1 and work 28 rows Ribbing. Transfer the Ribber sts. to main machine and continue in stockinette stitch.

ON EACH SIDE, increase 1 st. every 10th row 9x (9x) [11x]. After Row 130 (132) [132], bind off. Make second sleeve with COLOR 2.

# DK980

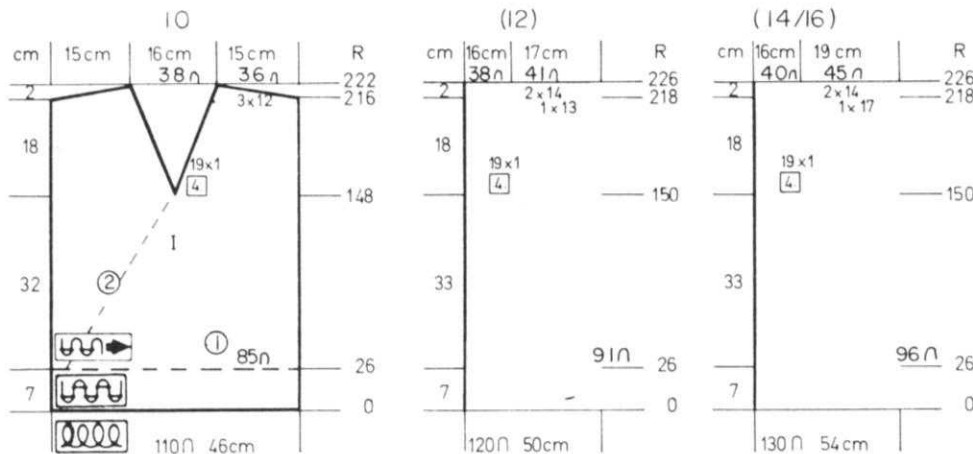

FRONT: I

Cast on 110 (120) [130] sts. with color 1 and work 26 rows Ribbing. Transfer the Ribber sts. to main machine and continue Stockinette stitch with Intarsia Design. Begin with 85 (91) [96] sts. on the right in color 1 and 25 (31) [34] sts. on the left in color 2. Work the Intarsia Design. ON EVERY 4th row DECREASE 1 st. on the right section and INCREASE 1 st. on the left section to Row 148 (150) [150]. Divide in the center, put the needles on the left into holding position and complete the right side first. \*SHAPE NECK: ON NECK SIDE, decrease 1 st. every 4th row 19x for all sizes and after Row 216 (218) [218] SHAPE SHOULDER same as the back. Bring the needles on the left into working position, Put the Row Counter back to 148 (150) [150] and complete the left half. Follow the instructions from \*.

BACK: II

Cast on 110 (120) [130] sts. with color 1 and work 26 rows Ribbing. Transfer the Ribber sts. and continue with Intarsia Design. Begin with 102 (108) [113] sts on right in color 1 and 8 (12) [17] sts. on left in color 2. ON EVERY 4th row, decrease 1 st. on the RIGHT section and INCREASE 1 st. on the LEFT section to Row 216 (218) [218] BUT AT THE SAME TIME, after Row 148 (150) [150], mark each side with contrast yarn for setting in sleeves. After Row 216 (218) [218], bind off the center 28 sts., put the needles on the left into holding position and complete the right side first. \*SHAPE SHOULDER AND NECK at the same time. \*FOR SHOULDER, bind off 12 sts. 3x (13 sts. 1x, 14 sts. 2x) [17 sts. 1x, 14 sts. 2x] FOR NECK, bind off 2 sts. 1 x, 3 sts. 1x for all sizes. Bring the needles on the left into working position, knit 1 row to the left side, turn the Row Counter back to 216 (218) [218] and complete the left half. Follow the instructions from \*.

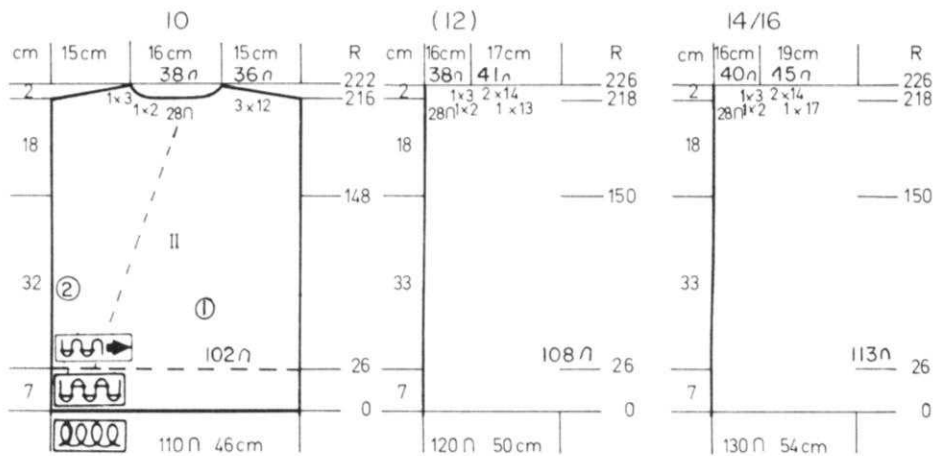

# HP981

MAN'S PULLOVER

SIZES: 40/42 (44/46)  
 YARN: Nomotta Viola  
 GRAMS: (See KNITTING NEWS)  
 color 1 300 350  
 color 2 200 250  
 TENSION: 8 or 9  
 GAUGE: 12 sts. 19 rows = 5 cm (2")

Stockinette stitch with stripes with bands in K1, P1 Ribbing. The purl side is the right side.

FINISHING: See General Instructions. Work several rows single crochet around neckline and front opening. Finish Buttonholes and sew on Buttons.



BACK: II

Cast on 132 (138) sts. with color 2 and wprl 22 rpw Ribbing. Continue in Stockinette stitch beginning with 4 rows color 1 then 4 rows color 2 and REPEAT these stripes to Row 148 then continue in Color 1 Knit to Row 226 (234). SHAPE SHOULDER: ON EACH SIDE, bind off 12 sts. 4x. (12 sts. 1x, 13 sts. 3x). Bind off the remaining sts.

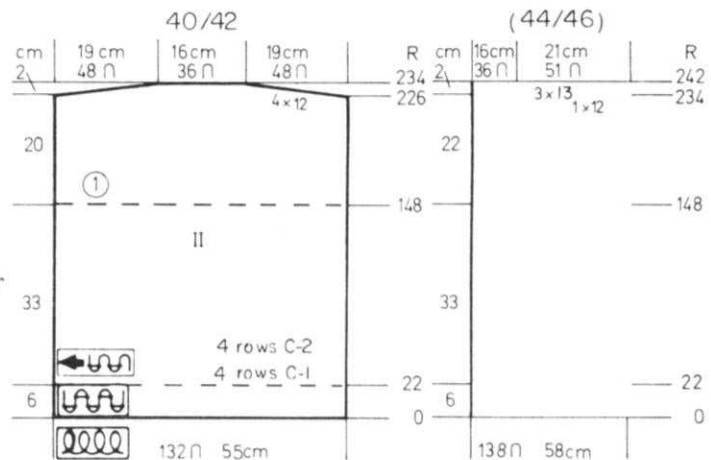

# HP981

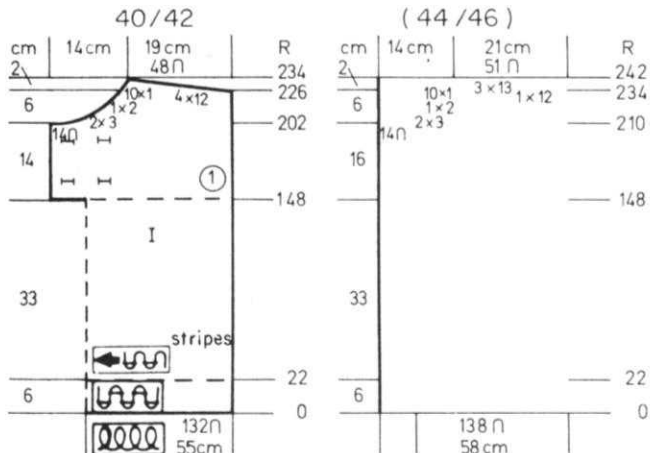

## LEFT FRONT: I

Cast on 132 (138) sts. with color 2 and work 22 rows Ribbing. Continue in Stockinette stitch with color stripes of 4 rows color 1 and 4 rows color 2 to Row 148. ON THE LEFT SIDE, cast on 14 sts. and continue in color 1. After Row 172, make Buttonholes over needles 5, 6, 7 and 22, 23, 24 counting from the left edge. REPEAT the buttonholes over same needles after Row 198. After Row 203, bind off the 14 sts. on the left then ON EVERY 2nd row, at neck edge, bind off 3 sts. 2x, 2 sts. 1x, 1 st. 10x and at the same time, after Row 226, (234) SHAPE SHOULDER same as the back. REVERSE SHAPING for the RIGHT front and omit the Buttonholes.

## SLEEVES: III

Cast on 60 sts. with color 2 and work 12 rows Ribbing. Continue in Stockinette stitch of 4 rows color 1, 4 rows color 2 to Row 96 (96) then continue in color 1. ON EACH SIDE, bind off 7 sts. 6x (8 sts. 6x) After Row 182 (190), bind off the remaining sts.

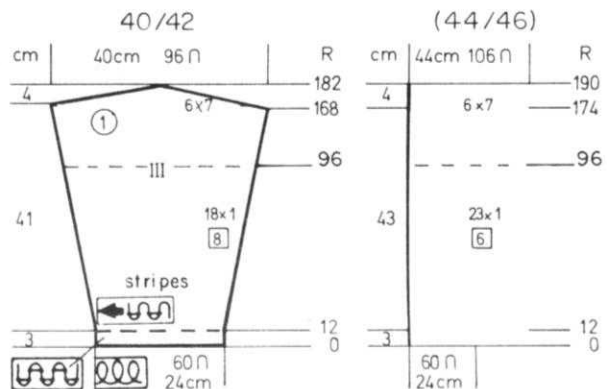

# HP982



## MAN'S VEST

SIZES: 36/38 (40/42) [44]  
YARN: Vienna

GRAMS:  
color 1 150 150 200  
color 2 50 100 100  
color 3 50 100 100  
color 4 50 100 100  
color 5 50 50 50

TENSION: 5 to 7  
GAUGE: 14 sts. 20 rows = 5 cm (2")

A Norwegian Design. Punch your own Card. The bands are K1, P1 Ribbing.

FINISHING: See General Instructions. Turn bands to the inside and sew in place. Sew 1 edge of Collar to the outside and 1 to the inside of neckline. Sew in a zipper down the front.

## FRONT BANDS:

With purl side facing you, pick up the sts. along front edge and with color 1, work 16 rows K1, P1 Ribbing. Transfer the Ribber sts. to main machine and bind off. Turn bands to the inside and sew in place.

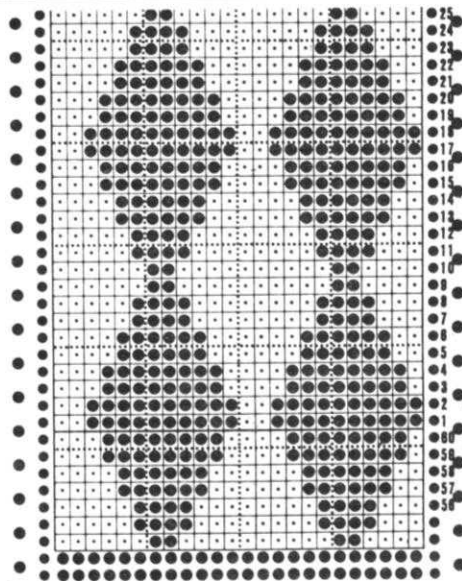

## BEGIN HERE:

\*8 Rows colors 1 & 3  
O 8 Rows colors 2 & 4  
□ 8 Rows colors 1 & 5  
△ 8 Rows colors 2 & 3  
REPEAT FROM \*.

REPEAT PUNCH CARD THROUGH ROW 41 then punch 2 rows of holes for connecting Card.



# HP982

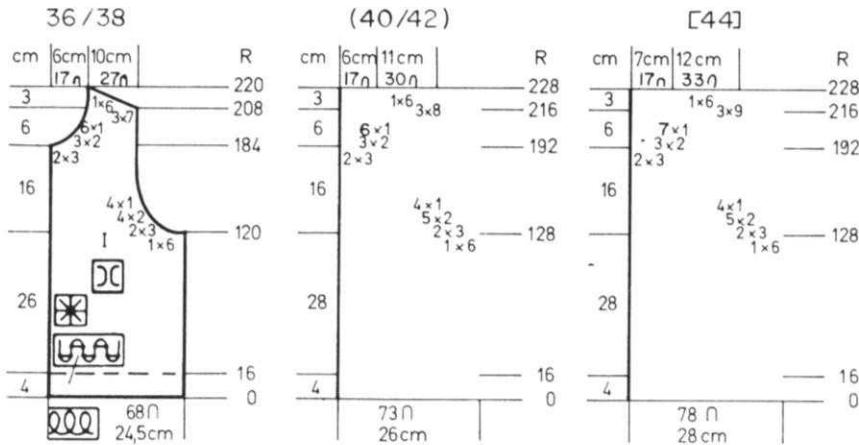

FRONT: I Make 1, reverse 1.

Cast on 68 (73) [78] sts. with color 1 and work 16 rows Ribbing. Continue in Pattern. Knit to Row 120 (128) [128]. SHAPE ARMHOLE same as the back then knit to Row 183 (191) [191]. SHAPE NECK: Bind off 3 sts. 2x, 2 sts. 3x, 1 st. 5x (5x) [6x] and adfter Row 208 (216) [216], SHAPE SHOULDER same as the back.

BACK: II

Cast on 142 (152) [162] sts. with color 1 and work 16 rows Ribbing. Continue in Pattern. Knit to Row 120 (128) [128]. SHAPE ARMHOLE: ON EACH SIDE bind off 6 sts. 1x, 3 sts. 2x, 2 sts. 4x, 1 st. 4x. (6 sts. 1x, 3 sts. 2x, 2 sts. 5x, 1 st. 4x). [Same as 2nd size]. Knit to Row 208 (216) [216]. SHAPE SHOULDER and watch for NECK SHAPING. FOR SHOULDER, ON EACH SIDE bind off 7 sts. 3x, 6 sts. 1x. (8 sts. 3x, 6 sts. 1x). [9 sts. 3x, 6 sts. 1x]. FOR NECK, after Row 212 (220) [220], bind off the center 30 (30) [34] sts., put the needles on the left into holding position and complete the right side first. \*ON NECK SIDE, bind off 3 sts. 1x, 2 sts. 1x for all sizes. Bring the needles on the left into working position, knit 1 row in Pattern to the left side, turn the Row Counter back to 212 (220) [220] and complete the left half. Follow the instructions from \* and don't forget to complete the shoulder shaping.

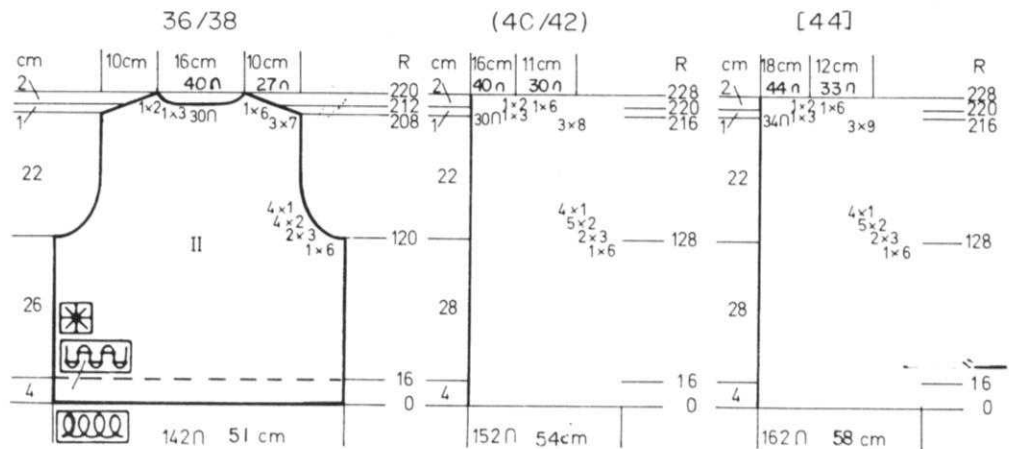

COLLAR:

Cast on 118 (118) [124] sts. with color 1 and work K1, P1 Ribbing. WORK SHORT ROWS: Put 30 sts. OPPOSITE Carriage into holding position before knitting the next 2 rows. ON OPPOSITE SIDE OF CARRIAGE, bring back into working position 3 sts. 10x ON EACH SIDE. (Row 22)

ON OPPOSITE SIDE OF CARRIAGE, put into holding position 3 sts. 10x ON EACH SIDE. ON OPPOSITE SIDE OF CARRIAGE, bring back all needles before knitting the next 2 rows. Transfer the Ribber sts. to main machine and bind off.

# DK983

WOMAN'S JACKET

SIZES: 8/10 (12) [14]  
 YARN: Vienna  
 GRAMS:  
 color 1 150 150 200  
 color 2 50 100 100  
 color 3 50 100 100  
 color 4 50 100 100  
 color 5 50 50 50  
 TENSION: 5 to 7  
 GAUGE: 14 sts. 20 rows = 5 cm (2")

A Norwegian Design. Punch your own Card. The bands are K1, P1 Ribbing.

FINISHING: See General Instructions.



BEGIN HERE:

\*8 Rows Colors 2 & 3  
 8 Rows Colors 1 & 4  
 8 rows Colors 2 & 5  
 REPEAT FROM \*

REPEAT PUNCH CARD THROUGH ROW 41 then punch 2 rows of holes for connecting Card.

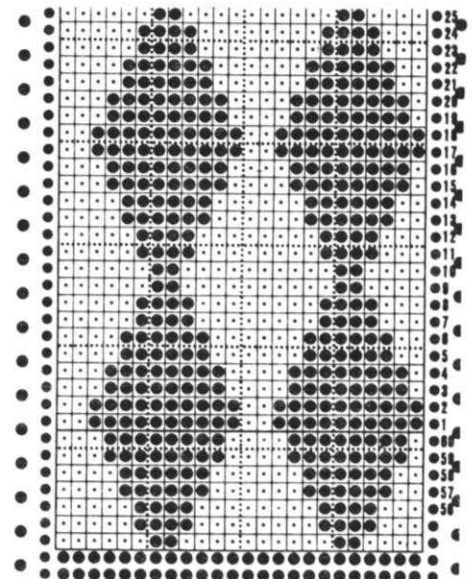

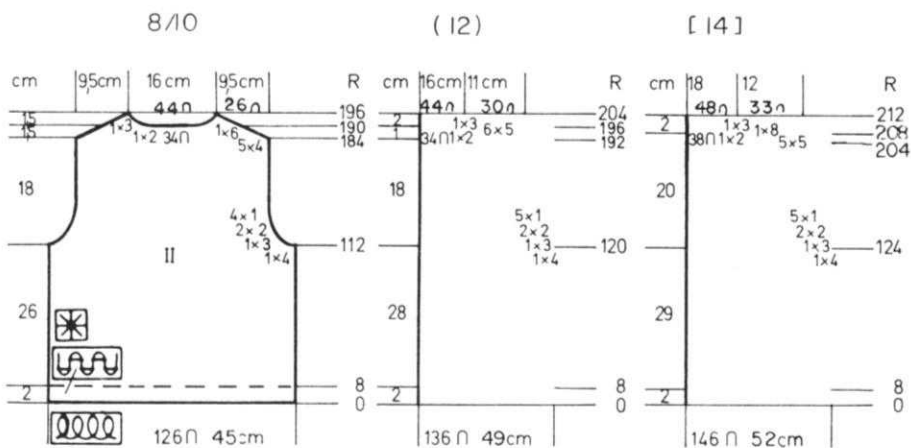

Cast on 126 [136 [146] sts. with color 1 and work 8 rows Ribbing. Knit 1 row 2 tensions higher, then with original tension, knit 8 rows and hang the hem. Continue in Pattern. Knit to Row 112 (120) [124]. SHAPE ARMHOLE: ON EACH SIDE, bind off 4 sts. 1x, 3 sts. 1x, 2 sts. 2x, 1 st. 4x. (4 sts. 1x, 3 sts. 1x, 2 sts. 2x, 1 st. 5x). [4 sts. 1x, 3 sts. 1x, 2 sts. 2x, 1 st. 5x]. Knit to Row 184 (192) [204]. SHAPE SHOULDER and watch for NECK SHAPING. For Shoulder, bind off 4 sts. 5x, 6 sts. 1x, (5 sts. 6x, 3 sts. 1x). [5 sts. 5x, 8 sts. 1x]. AT THE SAME TIME, after Row 190 (196) [208], bind off the center 34 (34) [38] sts., put the needles on the left into holding position and complete the right side first. \*ON NECK SIDE, bind off 2 sts. 1x, 3 sts. 1x for all sizes. Bring the needles on the left into working position, knit 1 row in Pattern to the left side, turn the Row Counter back to 190 (196) [208] and complete the left half. Follow the instructions from \* and don't forget to complete the shoulder shaping.

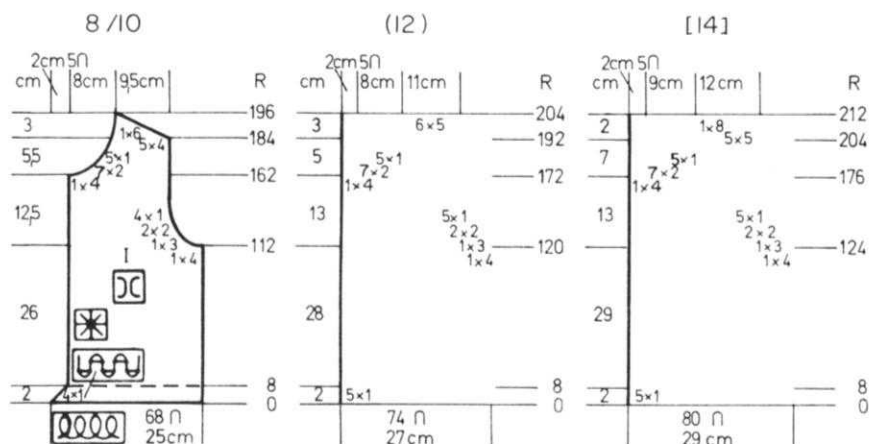

FRONT: I Make i, reverse l.

Cast on 68 (74) [80] sts. with color 1 and work the ribbing same as Back. Continue in Pattern. Knit to Row 112 (120) [124]. SHAPE ARMHOLE same as the back and after Row 161 (171) [175], ON NECK SIDE, bind off 4 sts. 1x, 2 sts. 7x, 1 st. 5x for all sizes. After Row 184 (192) [204], SHAPE SHOULDER same as the back.

FRONT BANDS:

Pick up the sts. along front edge and with color 1 work in Ribbing with hem same as front and back. After you hang the hem, bind off.

NECKBAND:

Sew shoulder seam first then pick up the sts. along neck edge and with color 1 work in Ribbing with hem same as front bands. Bind off.

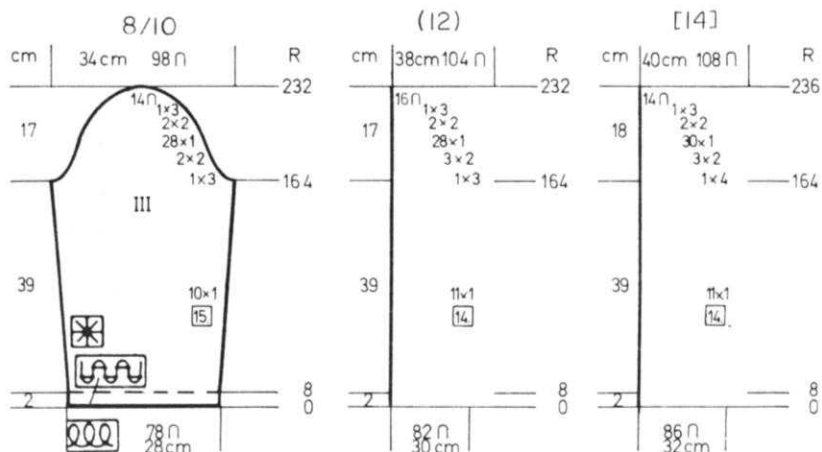

SLEEVES: III

Cast on 78 (82) [86] sts. with color 1 and work in Ribbing same as back then continue in Pattern. ON EACH SIDE, increase 1 st. every 15th row 10x. (every 14th row 11x). [every 14th row 11x]. After Row 164, SHAPE CAP: Please follow the Chart in your size for the CAP bind-offs on each side.

# New! New! New! from KNITKING

## intarsia pattern charts AND CHARTING ACCESSORY

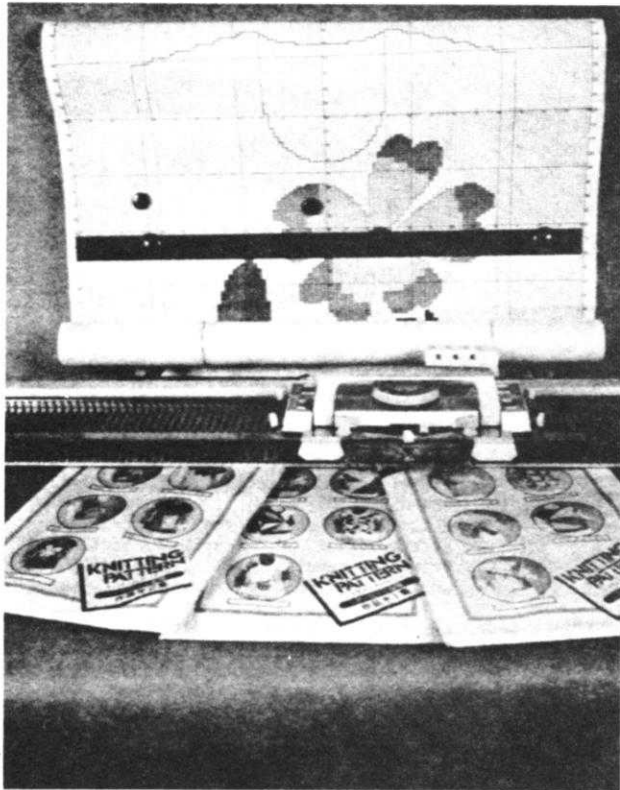

Made specifically for the JUMBO Knitter, these new Charts can also be transferred to your Knitleader and reproduced with the new INTARSIA FEEDER on the KH 840...

The CHARTING ACCESSORY fits the JUMBO Knitter... It is simple and efficient to use... The plastic row Ruler is held in place with Magnetic Buttons so that you always know exactly where you are.

There are three sets of Patterns with five to a set. Every Pattern is a Pullover but you can use the wonderful selection of Intarsia Designs on any garment...Skirts, Dresses, Coats, etc... Also included in our package deal is a packet of blank Charts so that you can draw your own patterns.

SPECIAL INTRODUCTORY PRICE  
FOR EVERYTHING... \$49.95

Calif. residents add Sales Tax.  
Shipping costs \$2.25

## knitking *announces their*

# SEMINAR

## *and open house*

# 1981



On the premises at 1128 Crenshaw Blvd., Los Angeles, Calif. 90019. Commencing-Monday, October 12th and running through Saturday, the 17th. During the five weekdays the Seminar will operate from 10 a.m. until 4 p.m., and on Saturday from 10 a.m until 1 p.m.

Admission will be FREE - Coffee and Doughnuts will be available at 9:30 a.m. daily. Plan to be with us and to meet the knitting experts at KNITKING. Classes and Lectures on all phases of machine knitting - Measuring - Charting, etc., will continue throughout every day.





# KNITTING NEWS

## PRACTICAL KNITTING HINTS

### SHORT ROW KNITTING FOR GARMENTS IN THIS ISSUE

There are several garments in this issue of KNITTING MAGAZINE knitted with SHORT ROWS. From time to time, we include an article on short row knitting in our Magazine and you should refer to them when you need a brush up on this procedure. In the meantime, we will explain our COVER GARMENT DK 971.

**SKIRT:** Use a lower tension when knitting the Skirt because of the fullness which causes a drop in the length.

Begin and end with waste yarn as stated in the instructions. After you have knitted 36 rows over all needles with Black - begin the SHORT ROWS. Set your machine for HOLDING NEEDLES.

\*ON OPPOSITE SIDE OF CARRIAGE, put into holding position 1 st. Knit across to the left side and bring 1 MORE needle into holding position and knit back to the right side (2 sts. in holding position) REPEAT FROM \* 19x more. You should have 40 sts. in holding position and you have AUTOMATICALLY wrapped a needle to prevent a hole by putting 1 needle (instead of 2) into holding then bringing the 2nd needle into holding after you have knitted across. Change to ORANGE and continue the short row knitting - REPEATING FROM \* as before until you have the 10 Orange rows. Change to Black and work the Short Rows the same way until 60 Black are in holding, change to Blue and work the same way till 52 Blue are in holding.

SET YOUR MACHINE FOR KNITTING ALL NEEDLES. With Black, knit 24 rows then with Blue knit 10 rows over all needles. Carriage on the right - Row Counter at 232. Change to White yarn.

Set your machine for HOLDING POSITION. Put all but 38 sts. on the right side into holding position. When pushing the needles into working position from holding, you must PUSH BACK 1 MORE than the instructions say - so put the 39th needle into working position and knit across, then bring the 39th needle BACK INTO HOLDING POSITION (automatic wrap).

\*\*Now push back into working position 3 sts., knit across and bring the 3rd (last needle in work) back into holding position, and knit back to the right side. You are actually returning 2 sts. to the knitting position by automatically wrapping the 3rd. REPEAT from\*\* until you have 60 sts in knitting position with White yarn. Work in the same way with 2 sts. 21x, pushing into work 3 sts., knit across and bringing 1 back into holding position - 42 sts. working in Black. Do the same for 2 sts. 30x with white yarn. Row Counter 432.

You can now continue to follow the Skirt Pattern instructions as given.

**TOP:** - When you have completed the 50 rows of Stockinette stitch and hung the hem, put 10 sts. on the LEFT into holding position and set your machine for HOLDING. With Black, knit 1 row to the left side. You do not need to wrap the one stitch you will put into holding position - so put 1 needle into holding every 2nd row 103x and remember to increase 1 st. on side edge every 8th row 10x and also to SHAPE THE ARMHOLE on the right after Row 136 as shown on the Chart. When you reach Row 256, you should have 4 sts. left. Put the 4 sts. into holding position and break the yarn. You should have 107 sts. in holding position. Take the Carriage off the machine and put it back on the left side. Turn the Row Counter back to 50 and push the 10 sts. PLUS 2 more (12) into working position. With White, knit across to the right and bring 1 needle back into holding position and knit back to the left side. Now continue to ALWAYS push 1 MORE (2) NEEDLE than called for into working position on the right, knit across and bring 1 back into holding position and knit back. You actually are bringing back 1 needle at a time but are using the 2nd one for the automatic wrapping. Don't forget to in-

crease 1 st. on side edge every 8th row 10x and after Row 136 SHAPE ARMHOLE same as you did before. When you reach Row 156 - you must continue to bring back the 1 st. on the right but you must ALSO begin SHORT ROWS on the left AT THE SAME TIME - so as before, bring 1 LESS stitch into holding position on the left (when Carriage is on the right) - Bring 2 sts. on the left into holding position, knit across to the left, then bring the 3rd into holding AND AT THE SAME TIME, continue to push back 2 sts. on the right (when Carriage is on the left) knit across and bring back 1 st. into holding for the automatic wrap. Continue the 2 plus 1 till the 3 sts. 12x is completed then you will work 1 plus 1, 38x to Row 256.

You are now ready to start the VIOLET color. Carriage on the left, Row Counter 156. ON THE LEFT, (work with Violet yarn) you must now put into holding position, 1 st. on the left and bring back 3 sts. 12x (remember push back 4 and then bring up 1 into holding) on the right. When 36 sts. are back into working position, then you bring back 2 sts. 38x (push back 3, bring up 1 etc.). You now must leave 66 sts. on the right in holding position when you work the VIOLET color, then the ORANGE color in the same way. When you have completed all colors to Row 256, take the Carriage to the right side, turn the Row Counter to 256 and with lower tension and white yarn, knit to Row 272. Bind off loosely. The back of the Top is Stockinette stitch using Black yarn and so is the right sleeve with an Orange band. The left sleeve is white with a Black band.

### YARNS FOR PATTERNS

When we knit garments for KNITTING MAGAZINE, we frequently knit them with cone yarns. Obviously it's faster and easier to knit directly from cones rather than going to the trouble of rewinding 50 gram balls into center pull balls... Sometimes however, it can be expensive to purchase 5 or 6 cones of yarns just to make up one garment... In this issue the Cover Garment DK 971 and DK 970 are modern multi-color garments that you can knit up in any yarn that will produce the stitch gauge called for. If you are like most machine knitters you will have stocks of yarns over from previously knitted garments in sufficient quantities to produce either of these outfits.

We knitted the striking Cover Garment in LINENA, the special purchase yarn we have made available to all subscribers in our SUMMER SALE mailing. DK 970 knits up beautifully in the Venetia we offered at a very low price during our Pre-Inventory Sale. You can make it in any good quality fingering weight wool or synthetic yarn.

DK 972 and DK 973 and DK 974 can also be made with LINENA or with the light weight low priced MOSSAIR also featured in our SUMMER SALE.

DK 977 can be knitted in a fine two-ply yarn. We tested a yarn called Souffle on it. We did not take delivery of the yarn in sufficient time for this issue but we will offer it before or in our next issue...

A new Nomotta yarn from Germany called Viola was used for DK 980 and HP 981. We have not yet decided to stock it, so you can use any yarn you choose or our SUMMER SALE Yarns WILLOW or POODLE knitted double will give you the stitch gauge... and a handy hint for when you knit with doubled or heavy yarns in stockinette stitch... Set your Change Knob (on 820/830/840) to KC and remove the two inside rotating brushes from the Sinker Plate Assembly.

### YARN KITS FOR THIS ISSUE OF KNITTING MAGAZINE

Be sure to take advantage of the specially discounted prices on Yarn Kits for the garments in this issue of KNITTING MAGAZINE. Please remember

that the special discounts are for subscribers only and are good until the next issue of the Magazine.

DISCOUNTS ON YARN KITS FOR THIS ISSUE

KK 959 - Yarn: Amore  
 SIZES: 4 (6)  
 Regular Price \$19.12 \$19.12  
 Sale Price 15.30 15.30  
 Shipping Costs 1.85 1.85

KK 960 - Yarn: Amore  
 SIZES: 4 (6)  
 Regular Price \$19.12 \$21.51  
 Sale Price 15.30 17.21  
 Shipping Costs 1.85 1.85

KK 961 - Yarn: Amore  
 SIZES: 6/8 (10)  
 Regular Price \$19.12 \$21.51  
 Sale Price 15.30 17.21  
 Shipping Costs 1.85 1.85

HP 962 - Yarn: Fortissima  
 SIZES: 34/36 (40/42)  
 Regular Price \$20.64 \$28.38  
 Sale Price 16.51 22.70  
 Shipping Costs 1.85 1.85

DK 963 - Yarn: Amore  
 SIZES: 10/12 (14)  
 Regular Price \$28.68 \$31.07  
 Sale Price 22.94 24.85  
 Shipping Costs 1.85 1.85

HP 964 - Yarn: Amore  
 SIZES: 34/36 (38/40)  
 Regular Price \$31.07 \$33.46  
 Sale Price 24.86 26.77  
 Shipping Costs 1.85 1.85

DK 965 - Yarn: Amore  
 SIZES: 7/8 (10)  
 Regular Price \$23.90 \$26.29  
 Sale Price 19.12 21.03  
 Shipping Costs 1.85 1.85

DK 966 - Yarn: Amore  
 SIZES: 8/10 (12)  
 Regular Price \$ 9.56 \$ 9.56  
 Sale Price 7.65 7.65  
 Shipping Costs 1.85 1.85

DK 967 - Yarn: Amore  
 SIZES: 8/10 (12)  
 Regular Price \$21.51 \$23.90  
 Sale Price 17.21 19.12  
 Shipping Costs 1.85 1.85

DK 968 - Yarn: Any yarn to give stitch and row Gauge. NO KIT AVAILABLE  
 SIZES: 8/10 (12/14)

DK 969 - Yarn: Any yarn to give stitch and row Gauge. NO KIT AVAILABLE  
 SIZES: 10/12 (14)

DK 970 - Yarn: Venetia - See KNITKING NEWS  
 SIZE: 8/10

DK 971 - Yarn: Linena - SEE KNITKING NEWS  
 SIZES: 10/12

DK 972 - Any fine yarn to give stitch & row gauge.  
 SIZES: 8/10 NO KIT AVAILABLE

DK 973 - Yarn: Any fine yarn to give stitch and row Gauge. NO KIT AVAILABLE

DK 974 - Yarn: Linena - SEE KNITKING NEWS  
 SIZES: 10/12

DK 975 - Yarn: Micaela  
 SIZE: Medium  
 Regular Price \$13.74  
 Sale Price 10.99  
 Shipping Costs 1.85

DK 976 - Yarn: Vienna  
 SIZES: 12/14  
 Regular Price \$24.30  
 Sale Price 19.44  
 Shipping Costs 1.85

DK 977 - Yarn: Any fine yarn to give stitch and row Gauge. Yarn used double for Skirt. NO KIT AVAILABLE  
 SIZES: 8/10

DK 978 - Yarn: Venetia - SEE KNITKING NEWS  
 SIZES: 8/10 (12)

DK 979 - Yarn: Crocus  
 SIZES: 8 (10)  
 Regular Price \$22.05 \$22.05  
 Sale Price 17.64 17.64  
 Shipping Costs 1.85 1.85

DK 980 - Yarn: Nomotta Viola - or any yarn to give stitch and row gauge.  
 NO KIT AVAILABLE  
 SIZES: 10 (12) [14/16]

HP 981 - Yarn: Nomotta Viola - or any yarn to give stitch and row gauge.  
 NO KIT AVAILABLE  
 SIZES: 40/42 (44/46)

HP 982 - Yarn: Vienna  
 SIZES: 36/38 (40/42) [44]  
 Regular Price \$18.90 \$27.00 \$29.70  
 Sale Price 15.12 21.60 23.76  
 Shipping Costs 1.85 1.85 1.85

DK 983 - Yarn: Vienna  
 SIZES: 8/10 (12) [14]  
 Regular Price \$18.90 \$27.00 \$29.70  
 Sale Price 15.12 21.60 23.76  
 Shipping Costs 1.85 1.85 1.85

DK968

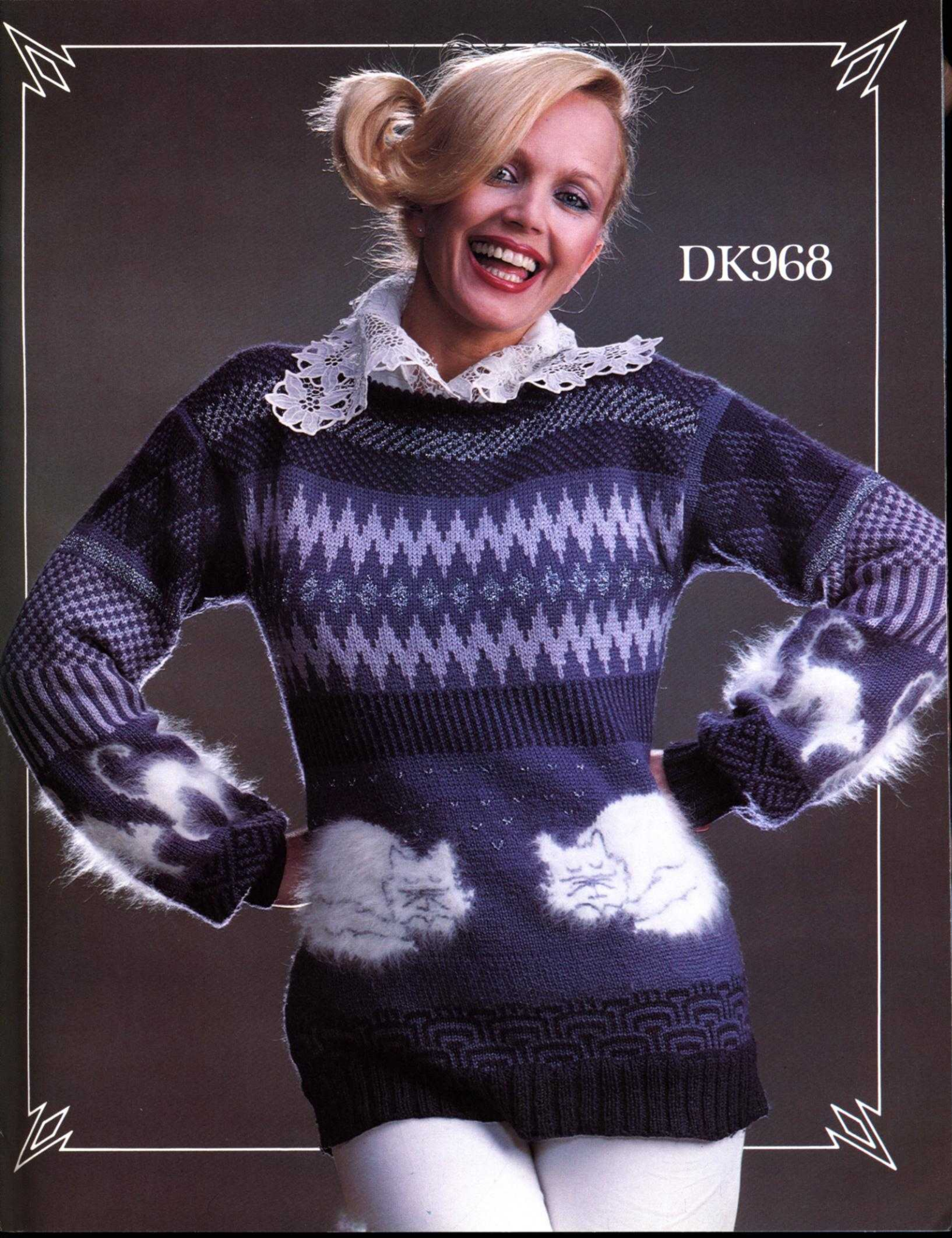



DK963

HP964

DK980

HP981

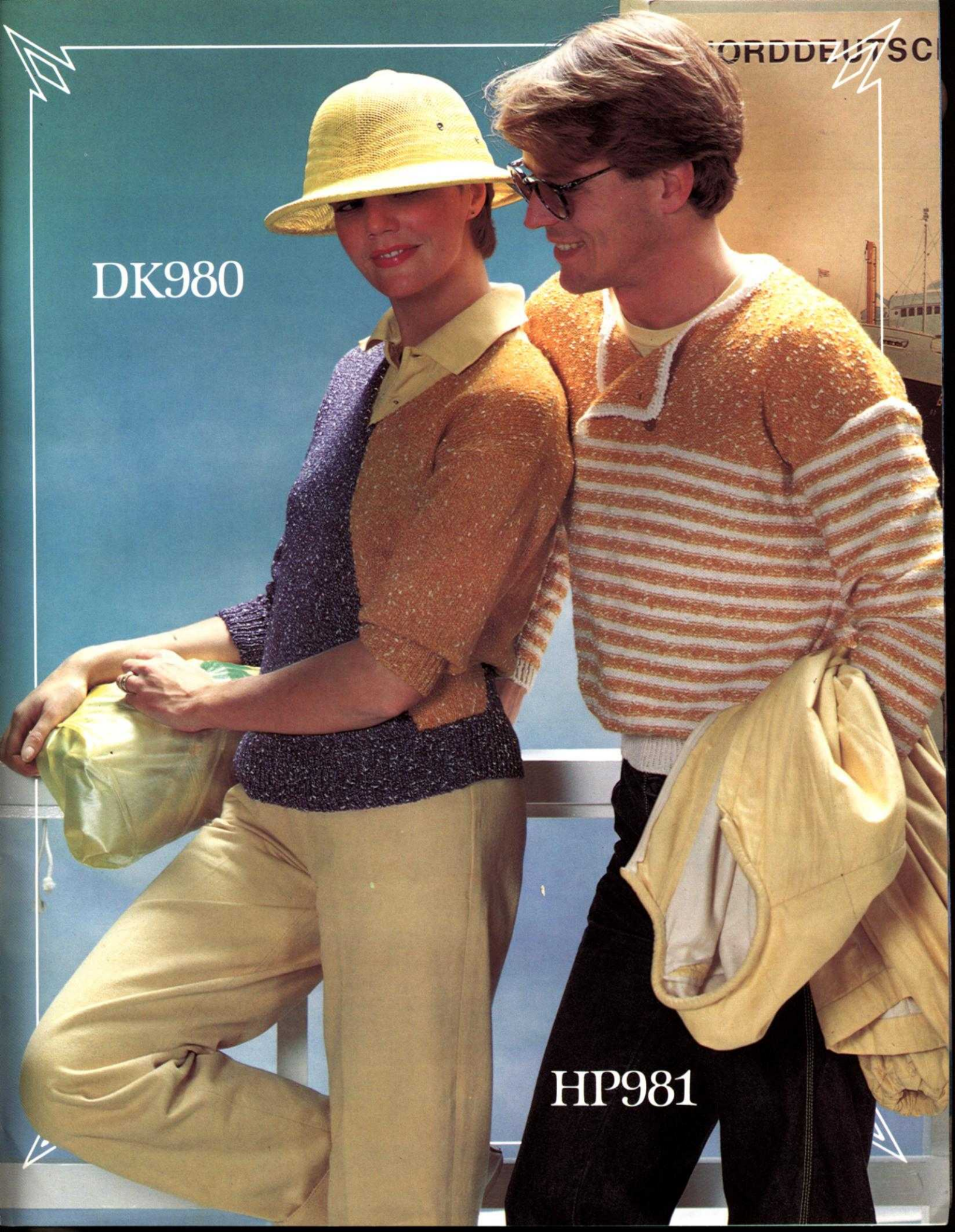



DK966



DK965



DK967



TOV  
TEM  
**NO PARKING**  
**6 A.M. TO 6 P.M.**  
L.A. TRAFFIC DEPT.



DK979

DK983

HP982





KK961

KK960

KK959

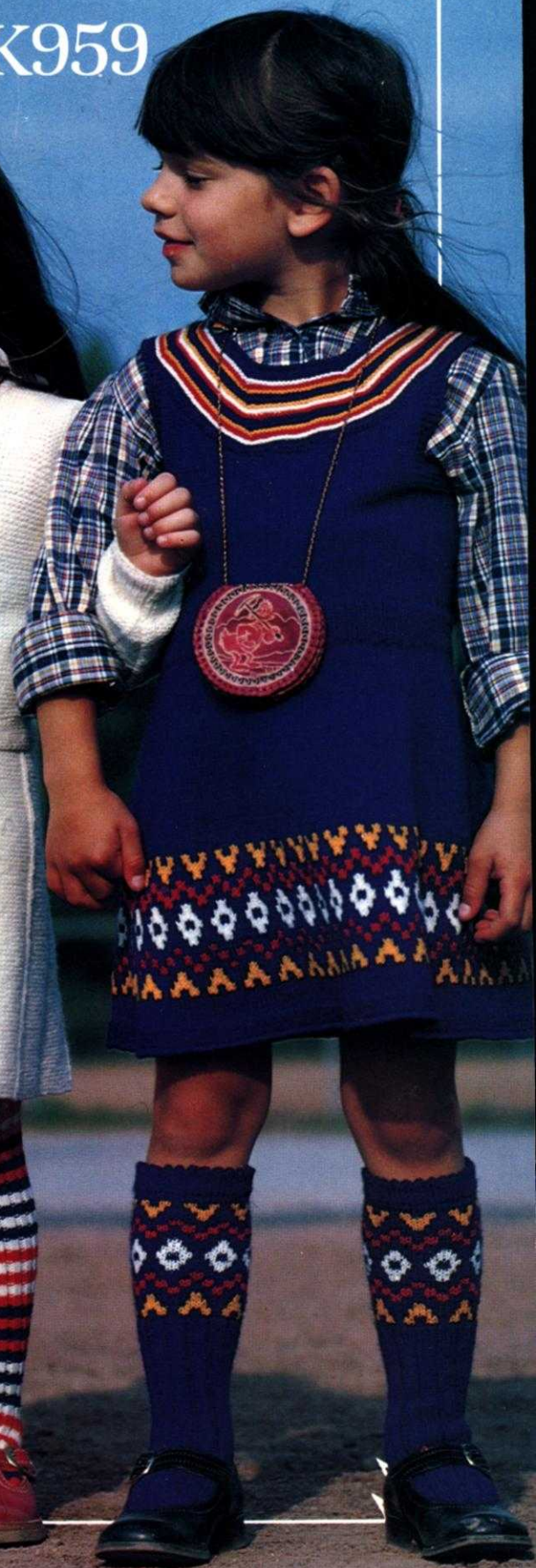

HP962

