

knitking
magazine



Show-Off Knits!

411

Town and Country Look

Another perfect ensemble for all seasons. Knit the Skirt using Pattern 410, then whip up the matching Vest with a colorful trim. All K1, P3 Ribbing. Sizes 6 to 16.

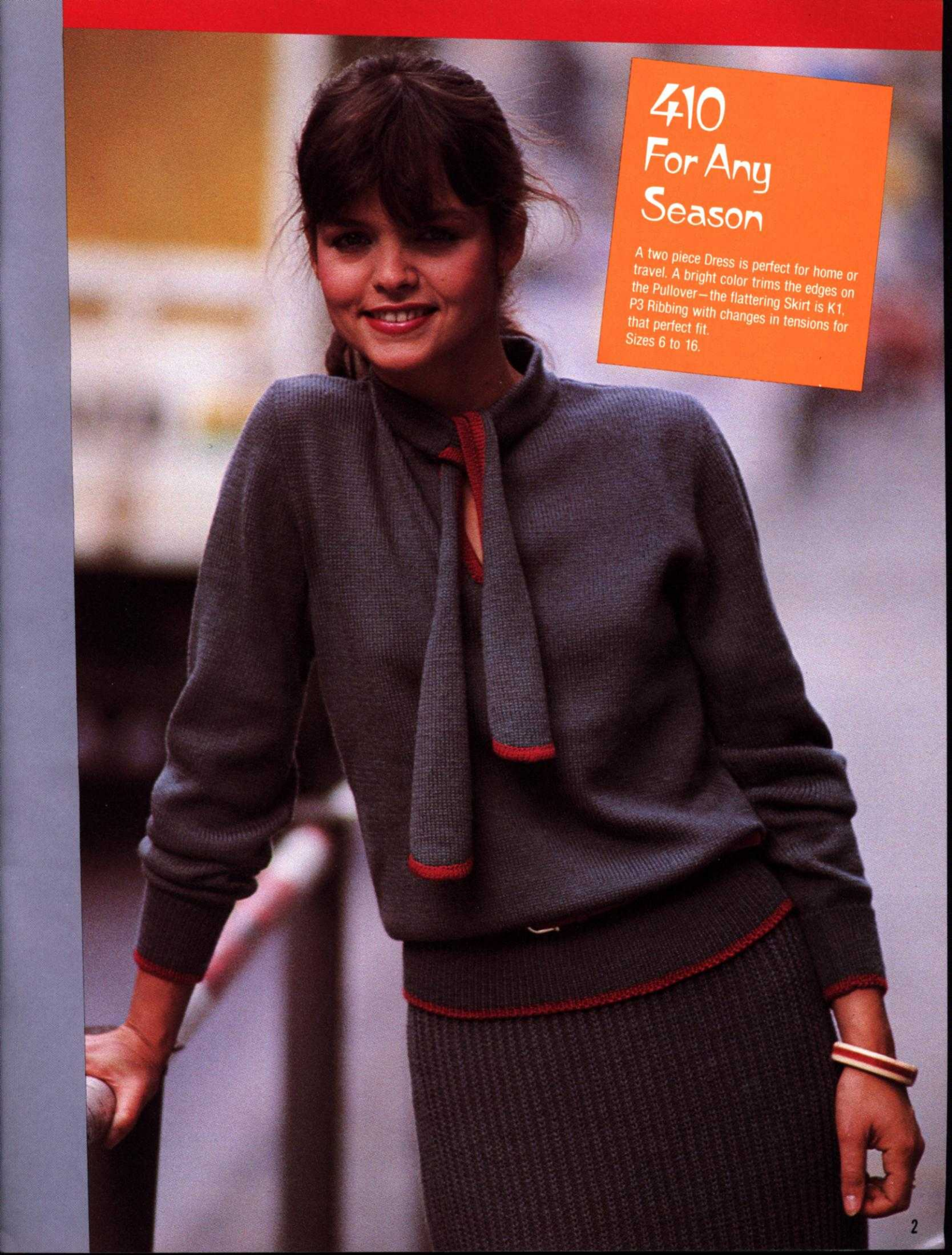

A woman with dark hair and bangs is smiling and looking towards the camera. She is wearing a grey, textured knit two-piece dress. The top is a long-sleeved pullover with a high collar and a large, vertical tie detail at the center. The skirt is a matching length, also with a textured knit pattern. Red trim is visible at the collar, cuffs, hem, and the ends of the tie. She is wearing a gold and red bangle on her left wrist. The background is a blurred indoor setting.

410 For Any Season

A two piece Dress is perfect for home or travel. A bright color trims the edges on the Pullover—the flattering Skirt is K1, P3 Ribbing with changes in tensions for that perfect fit.
Sizes 6 to 16.

Table of Contents

	PAGE NO.
400—Man's Argyle Pullover	13
401—Woman's Argyle Pullover	13
402—Woman's Pullover	15
403—Woman's Pullover	16
404—Woman's Striped Pullover	17
405—Man's Fairisle Pullover	18
406—Woman's Striped Jacket & Top	19
407—Girl's Pullover	21
408—Woman's Long Pullover or Mini Dress	22
409—Woman's Pullover	23
410—Woman's Two Piece Dress	24
411—Woman's Vest and Skirt	26
412—Man's Pullover	27
413—Woman's Pullover	28
414—Woman's Striped Pullover	30
415—Woman's Pullover, Shawl & Leg Warmers	31
416—Woman's Pullover	32
417—Woman's Pullover	33
418—Woman's Summer Top	34
419—Man's Fisherman's Rib Pullover	35
420—Woman's Cardigan	36
KNITKING NEWS	38

Editorial

Just when we thought there was very little that could be done to improve the efficiency of the KH 881 Punch Card KNITKING, the brilliant engineers whose job it is to strive to stay ahead of competition with innovations and improvements, produced a marvel of engineering skill and at the same time solved a previously insurmountable problem: How to knit Garter Stitch and Garter Stitch Designs on a basic knitting machine without completely reversing the knitting manually row by row or without using a Ribbing Attachment. We refer of course to the KG 88 and KG 89 Electric Carriages—now abbreviated to Garter Carriages—revolutionary design additions to home knitting machine equipment.

We first heard of the KG 88 for use with the KH 881 and the KH 860 Punch Card knitting machines plus the KH 910 Electronic. Our immediate reaction was disbelief. We had to see one in action to believe it...One was flown over and it has been in almost continual operation (incidentally without the slightest problem) for 5 months. We have produced two garments for this (No's. 406 and 412) issue and several garments for future issues of KNITKING MAGAZINE and experimented with many standard punch cards to produce some outstanding Garter Stitch Designs.

Now we introduce the new KH 891 KNITKING with the KG 89 Carriage, illustrated on page 46. The KH 891 functions similarly to the KH 881 except that the track on which the Garter Carriage runs is built in. This means that the Lace Carriage and the Main Carriage of the 891 operates over the built in track whereas the track for the KG 88 that fits the KH 910, the KH 881 and the KH 860 needs to be removed before their corresponding Lace and Main Carriage can be used. It also means that Garter Stitch and Lace Designs can easily be included in the same garment when knitted on the KH 891 with the KG 89 Carriage and that extra rows of colors or Tuck Stitch or Fairisle can be knitted into a garment without the removal of a track.

The new Garter Carriages are indeed the greatest innovation for home knitters since the introduction of the KH 910 Electronic CompuKnit and we feel sure that they will rapidly become a standard part of home knitting machine equipment.

We will be demonstrating and showing them at our annual Seminar (from October 8th to October 13th) in our Los Angeles Center. They will also be demonstrated at the Los Angeles County Fair running from September 13th through the 30th, at the Fair Grounds in Pomona. Readers living in Southern California can get a preview at our Booth in the Home Building, Building 6.

414

Especially Yours



Make your entrance count...in any of our beautiful garments. All are designed for 'best of show.' Knit our Cover Model in your favorite color combination. For beginners and experts.
Sizes 6 to 16.

Publisher: KNITKING CORPORATION, 1128 Crenshaw Blvd., Los Angeles, Calif. 90019. Telephone: (213) 938-2079. Published quarterly. Subscriptions: USA — \$18.00 annually, single copies \$5.00. \$21.00 all other countries. The entire contents of KNITKING MAGAZINE are copyright and must not be reproduced in any shape or form without the express permission, in writing, of the publisher.
©COPYRIGHT 1984 by KNITKING CORPORATION.

400-401

Argyle Brights....

Eye catching Pullovers for her and for him are a challenge in short row knitting—for the front section only.—Stripe the back and sleeves and Rib the bands. Sizes 10/12 for her—42/44 for him.



402 Classy!

A classy Pullover becomes a feminine beauty with a diagonal Eyelet Design. Embroider the large french knots for the bobbles. The bands are K1, P1 Ribbing. It's easy and quick to knit.
Sizes 6 to 16.





415 Ski Togs

Take to the slopes in a complete ensemble...A warm Pullover, Leg Warmers and Hooded Scarf. Can be made on any Bulky machine with Ribber. Use the Intarsia method or Short Row knitting. Sizes Small, Medium/Large.



417 Mix and Match

This colorful designer Pullover has a bit of everything. Not for beginners, it's a challenge in knitting and you can wear it with pride.
Sizes Medium and Large.



418 Tops for Summer

Knit a really sumptuous Top in pastel colors. Practice using your garter (reversing) bar for the purl stitch outlines. It's made on the diagonal so do follow the explicit instructions. Sizes 6 to 16.

413 High Style

Colorful Intarsia knitting is on the front and back of an interesting Pullover. You should use your Intarsia Carriage. The Sleeves are striped with bands in K1, P1 Ribbing. Sizes 6 to 16.

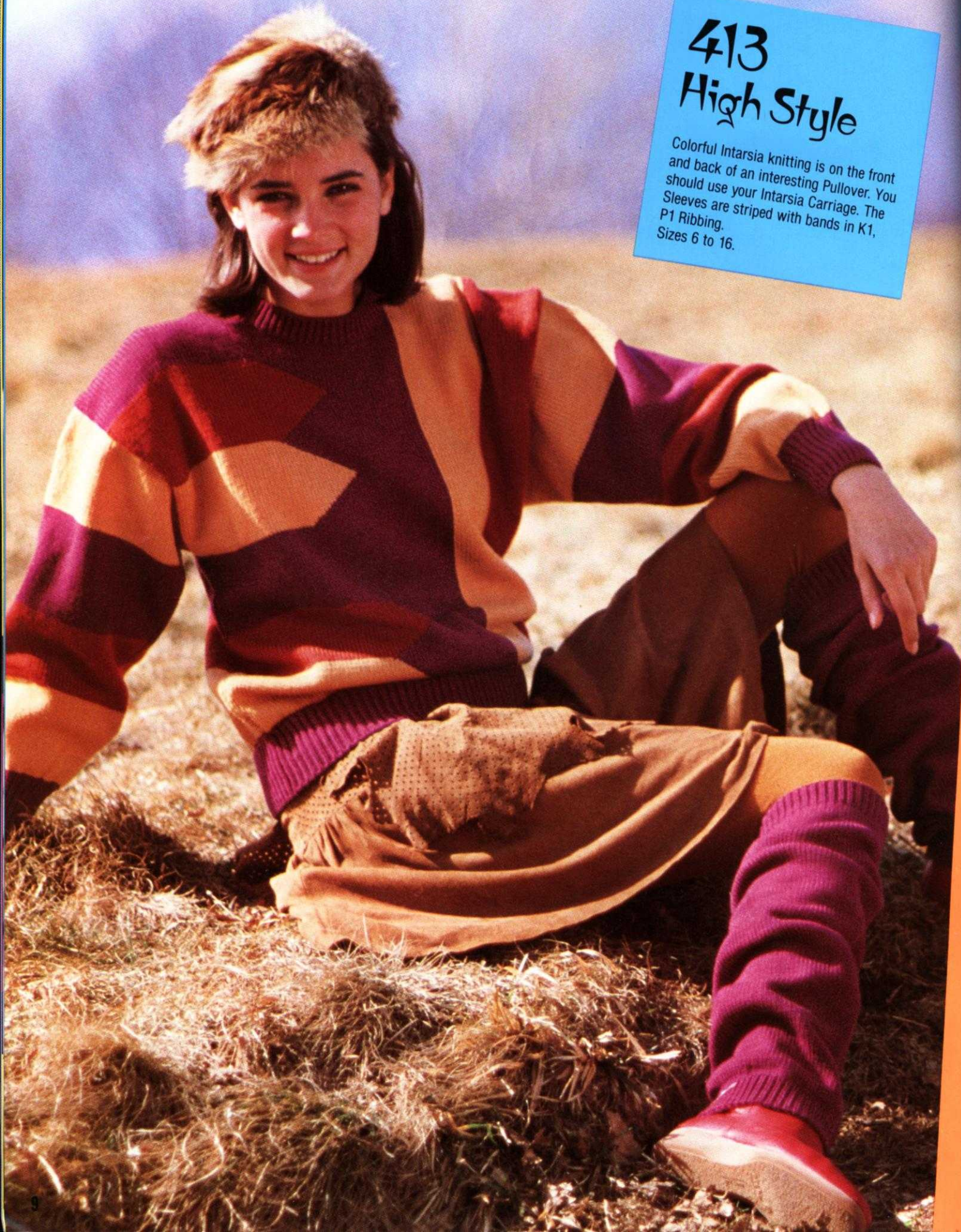

416 Pretty and Practical

A sideways knitted Pullover was made on the KH 230 Bulky machine with Ribber (Can be made on any Bulky machine). Get acquainted with Intarsia knitting and you will be surprised how easy it is...and fun too.
Sizes 6 to 16.





403-404
Bulky is In....

Knit either or both of these sweaters with our beautiful Multi-Show yarn. Stripe one, knit the other plain. Fast and easy knitting on any bulky machine. Sizes 6 to 16.

General Instructions

THE PRINTED INSTRUCTIONS

Follow the printed instructions or use them in combination with the Charts. Where there is any question in the instructions, you have the Charts to show you how the section will look.

Be sure to READ AHEAD so that you KNOW what to do for the size you are knitting. In the shapings, where the number of stitches are the same but the number of times different, you might find shapings like this...3 sts. 1 x (2x) [3x]—so that for the first size you will bind off 3 sts. 1x, 2nd size 3 sts. 2x, 3rd size 3 sts. 3x. Sometimes the ROWS will be different for each size—so you must watch out for different row numbers.

Shoulder and neck shapings for the back section of a garment usually are shaped at the same time—so ALWAYS WATCH for the words AT THE SAME TIME.

HOLDING STITCHES ON THE LEFT SIDE WHILE SHAPING THE RIGHT SIDE

There are different ways to hold stitches on one side while completing the other side. Usually, we tell you to bind off the center sts. for neck and put the left side into holding position while completing the right side. The easiest way and really the best way for beginners is to take a piece of RAVEL CORD and hand knit the center neck stitches, pulling them back against the needle bed of machine to the "A" or out of work position. The stitches remain in the HOOKS of the needles so you are really only knitting them HALF WAY. With another color of Ravel Cord, knit the remaining sts. on the left side in the SAME WAY.

It is important to protect these held stitches in some way—so you can either hang a REVERSING BAR so that the EYES of the Bar go BETWEEN the Gate Pegs on the machine and that the UPPER TIPS of Bar only—show above the needle bed...OR the simplest way is to use a piece of 1 inch masking tape and GENTLY place it beneath the knitting—right below the gate pegs. Do NOT press the tape—only enough pressure to hold it in place. This will prevent the Carriage (or Slide) from marking the held section.

It is VERY IMPORTANT that you mark the PATTERN ROW where you divide for the split for NECK (or SHOULDER) shaping....If you are using a PUNCH CARD—MARK THE CARD—if you are using an ELECTRONIC machine, MARK THE DESIGN WINDOW. Also take note of the Row number for the division. When you are ready to work the left section, bring the HELD stitches back to B (working) position by pulling each end of the Ravel Cord GENTLY and rip it off—be sure to align all needles straight in the B or knitting position.

Now you are ready to REFER TO YOUR OWN INSTRUCTION MANUAL for your machine—to set the controls to begin knitting the left half. The neck stitches can be bound off after completing the right side or you can leave them in hold until each side is finished, then bind them off or remove them onto contrast waste yarn ready to be picked up for knitting a neckband or for other finishing.

FULL FASHION DECREASING OR INCREASING

For Stockinette stitch, use the Full Fashion method for decreasing or increasing (except for regular cap shaping on sleeves where you decrease the edge stitch).

TO DECREASE: Hang the 3rd stitch onto the 2nd stitch then move the end stitches in to fill the empty needle.

TO INCREASE: Move the 2nd end stitches 1 needle outward, then pick up the 3rd stitch from the row below and hang it onto empty needle.

PATTERN SYMBOLS

() Symbol for 2nd size.

[] Symbol for 3rd size.

There are up to 3 sizes given for Patterns in KNITTING MAGAZINE. For example, the Charts and printed instructions will show the cast-on as...124—First size. (132)—Second size. [140]—Third size.

R= ROW

☐ Needles in holding position.

☒ Needles back into working position.

For Short Row Knitting

THE SAMPLE SWATCH

Before you knit any garment, you must knit a sample swatch using the yarn you have chosen for your garment. If you do not get the correct Stitch and Row Gauge as given for a Pattern in KNITTING MAGAZINE—try different tensions. If you are using the specified yarn, you should be able to get the correct gauge using one of the tensions shown. If you are using other yarns, you may have to make several swatches—but the gauge is very important.

To make a sample swatch—Cast on 60 stitches with waste yarn and knit 6 rows. Mark the tension number for your sample swatch by making holes (you can do this with a Lace Carriage or by hand), 4 transfers for Tension 4, 6 transfers for Tension 6, etc. Knit 6 more rows.

Change to garment yarn and set Counter at 0. Knit 30 rows (in Stockinette stitch or Pattern stitch—according to the garment). With contrast waste yarn knit the 10th stitch FROM EACH SIDE—by hand. Knit 30 rows. Change to waste yarn and knit 12 rows. Remove the sts. from the machine by pushing the Carriage (or Slide) across without yarn.

Pull and stretch the sample swatch both lengthwise and diagonally from corner to corner, then lengthwise again. Gently block the swatch (KNITTING PRESSING CLOTHS are great for this)—or you can allow the sample to rest several hours or even over night so that the stitches can return to their basic form. USE KNITTING CONVERTA TAPE for MEASURING YOUR SAMPLE (or the KNITTING INSTANT STITCH AND ROW GAUGE MEASURE).

If you use the Converta Tape, pull out the Tape to measure BETWEEN the 40 marked stitches in the center of your swatch. Move the red marker on the Tape so that it points to 40 stitches on the TAPE. Your stitch gauge to 2" (5 cm) will show in the RED WINDOW. To find the number of rows in 2" (5 cm), place the Tape to measure over the 60 rows, push the red marker to 60 on the Tape and your row gauge for 2" (5 cm) will show in the red window.

If you do not own a KNITTING CONVERTA TAPE or a Stitch and Row Measure, you must count the number of stitches and rows to 2" (5 cm) after marking a 2-inch square in the center of your knitting.

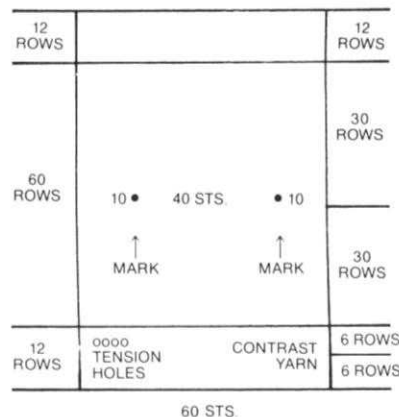

FINISHING

Gently block all sections—For PULLOVERS, JACKETS and DRESSES: Join the front to back at shoulders and sides. Sew sleeves together and set in. Hem lower edge and sleeve edges if needed. For a double neckband or armhole, band sew 1 edge to inside and 1 to the outside of neck or armhole. For a single ribbed band, sew 1 edge to the outside of neck or armhole edge. For a cardigan or jacket with buttonholes, finish buttonholes and sew on buttons.

PANTS: Join front to back at sides. Sew inside leg seams, then join to center front and back. Make hem at waistline and insert elastic. Hem lower edge of pants' legs.

☐ Needle not used—in out of work position.

3x1

☐ The number in the box is the number of Rows between shapings. The 3 x 1 above the box gives you the sts. and number of times to make the decreases (or increases)—FOR EXAMPLE: 3 x 1 over the box with 4 means—At the given Row number, *decrease 1 st. knit 4 rows* and REPEAT from * to * 2 times more for a total of 3 times in all. All decreasing (or increasing) WITHOUT ROW NUMBER IN BOX must be made on EVERY 2nd ROW.



400 - MAN'S ARGYLE PULLOVER
401 - WOMAN'S ARGYLE PULLOVER

SIZES:

MAN'S - 42/44
WOMAN'S - 10/12

YARN: Venetia

AMOUNT:

color 1 5 oz.
color 2 2 oz.
color 3 2 oz.
color 4 4 oz.
color 5 2 oz.
color 6 2 oz.
color 7 1 oz.

TENSION - 6.1 for Man's-Rib 3/2 II
4.1 for Woman's-Rib 1/0.2 II

GAUGE:

MAN'S - 15 sts. 23 rows = 2" (5 cm)
WOMAN'S - 17 sts. 25 rows = 2" (5 cm)

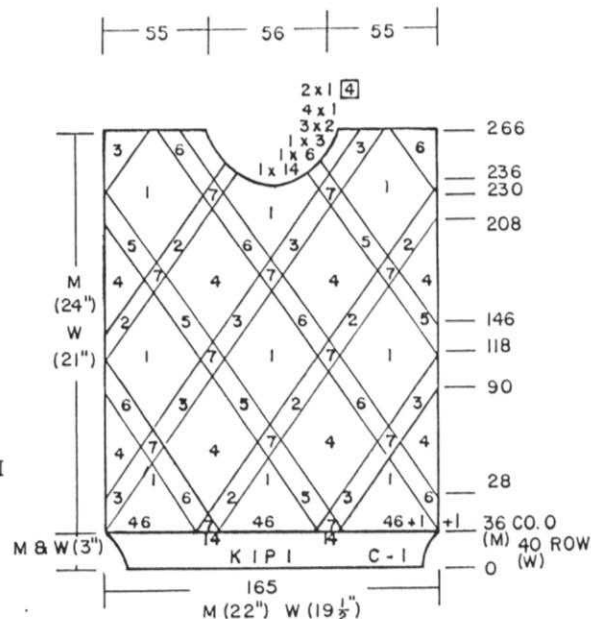

BACK:

Cast on 165 sts. with color 1 and work K1, P1 Ribbing - 36 rows for Man's and 40 rows for Woman's. Transfer the Ribber sts. to main machine, increase 1 st. on the right side and PUT COUNTER AT 0. Continue in Stockinette stitch with color stripes as follows. AT THE SAME TIME, watch for Neck Shaping. Use Garment Tension.

- 10 rows color 2
- 22 rows color 1
- 10 rows color 3
- 26 rows color 4
- 10 rows color 5
- 22 rows color 1
- 10 rows color 2
- 26 rows color 4
- 10 rows color 6
- 22 rows color 1
- 10 rows color 3
- 26 rows color 4
- 10 rows color 5
- 22 rows color 1
- 10 rows color 2
- 20 rows color 4 (TOTAL 266 rows)

BE SURE TO MARK EACH SIDE AFTER ROW 118 for Setting in sleeves.

After row 260, bind off the center 46 sts. for neck. Put the needles on the left into holding position and complete the the right side first.

*ON NECK SIDE, bind off 2 sts. 2x, 1 st. 1x. After Row 266, bind off. Bring the needles on the left into working position, knit 1 row to the left, turn the Row Counter Counter back to 260 and complete the left half. Follow the instructions from *.

The Instructions for the Man's and Woman's Argyle Pullovers are EXACTLY THE SAME. Only the Tensions used are different and this changes the sizes. You can use SHORT ROWS or INTARSIA for the Design. The Back and Sleeves are striped. Follow the Instructions for all Color Changes and for knitting the Argyle Design using Short Rows. Bands are K1, P1 Ribbing.

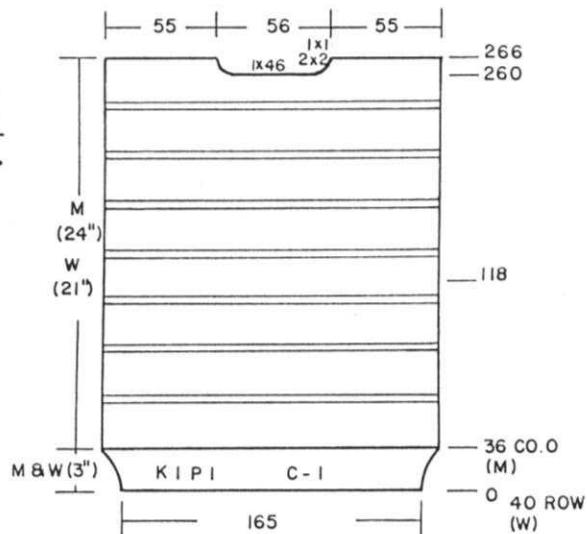

FRONT:

Cast on 165 sts. with color 1 and work K1, P1 Ribbing - 36 rows for Man's, 40 rows for Woman's. Transfer the ribber sts. to main machine and increase 1 st. on the right side.

Counter at 0. Change to garment Tension.

Begin the Argyle Design, using Short Rows (or Intarsia). If working Short Rows, BE SURE TO ALWAYS WRAP THE INSIDE NEEDLE IN HOLDING POSITION.

Follow LINE DRAWING No. 1, then No. 2, then No. 3 and follow the CHART for the color changes.

After Row 236, bind off the center 14 sts. for neck, and continue on the right side only.

The right side is completed after Row 266.

Work the left half with reverse shaping.

SLEEVES:

Cast on 75 sts. with color 1 and work 36 rows K1, P1 Ribbing. Transfer the ribber sts. to main machine and increase 1 st. on the right side.

Put Counter at 0 and continue in Stockinette stitch with color stripes as given below and AT THE SAME TIME ON EACH SIDE, increase 1 st. every 7th row 32x.

- 16 rows color 1
 - 10 rows color 3
 - 26 rows color 4
 - 10 rows color 5
 - 22 rows color 1
 - 10 rows color 2
 - 26 rows color 4
 - 10 rows color 6
 - 22 rows color 1
 - 10 rows color 3
 - 26 rows color 4
 - 10 rows color 5
 - 22 rows color 1
 - 10 rows color 2 (TOTAL 230 rows)
- After Row 230, remove the sts. onto contrast waste yarn.

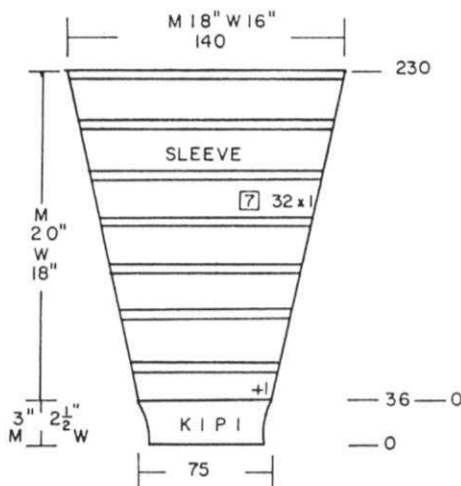

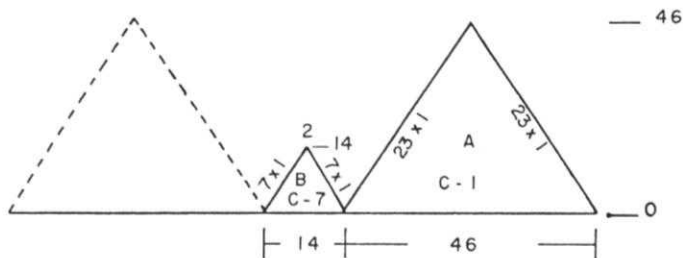

#1



NECKBAND: Sew 1 shoulder first.

Cast on 171 sts. with color 1 and work 12 rows K1, P1 Ribbing. Transfer the ribber sts. to main machine. Pick up the sts. around the neck and hang them onto these sts. Knit 1 LOOSE ROW then bind off.

FINISHING: See General Instructions. Weave the open sts. of sleeves to front and back first, then close side seams.

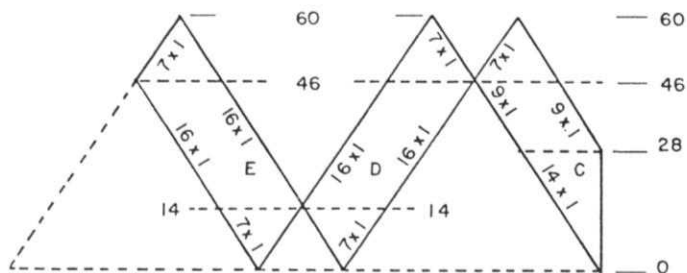

#2

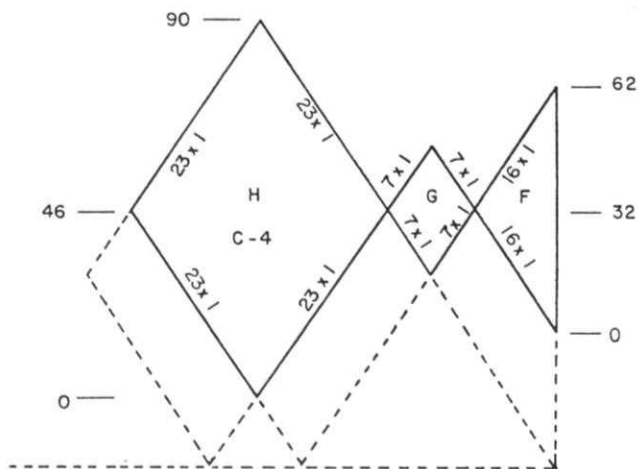

#3



IT'S READY NOW!

KNITKING MAGAZINE
BOUND VOLUME NO. 18

- HARD BOARD COVER
- COMPLETE INSTRUCTIONS
- WILL HOLD ANOTHER COMPLETE VOLUME

PRICE \$23.95
Shipping Costs \$3.25



SLEEVE BANDS:

Cast on 41 (43) [47] sts. and work 20 rows K1, P1 Ribbing. Transfer the ribber sts. to main machine then hang the open sts. from sleeve onto the machine, doubling every 2nd stitch (approximately). Knit 1 row FROM LEFT TO RIGHT, then bind off the crochet method, holding yarn BEHIND the gate pegs.

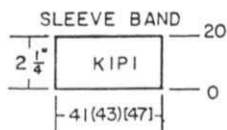
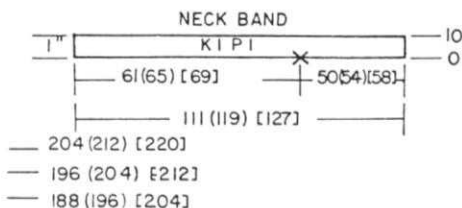

NECKBAND:

Close left shoulder first. Cast on 111 (119) [127] sts. and work 10 rows K1, P1 Ribbing. Transfer the ribber sts. to main machine and with purl side facing you, hang the neckline onto machine have 61 (65) [69] sts. across the front neck and 50 (54) [58] sts. across the back neck. Knit 1 row from LEFT to right then bind off the same as you did for sleeves.

FINISHING: See General Instructions. Make French Knots for Bobbles, using 4 strands of yarn, wrap 3 or 4 times around large needle. Place bobbles between eyelets as shown in picture.

403



WOMAN'S PULLOVER

SIZES: 6/8 (10/12) [14/16]
YARN: Multi-Show
GRAMS: 450 500 500
TENSION: 7.1 to 8
GAUGE: 7 1/2 sts. 10 1/2 rows = 2" (5 cm)

Made on the 230 BULKY machine or any BULKY machine. Stockinette stitch with bands in K1, P1 Ribbing using Tension 4/3.

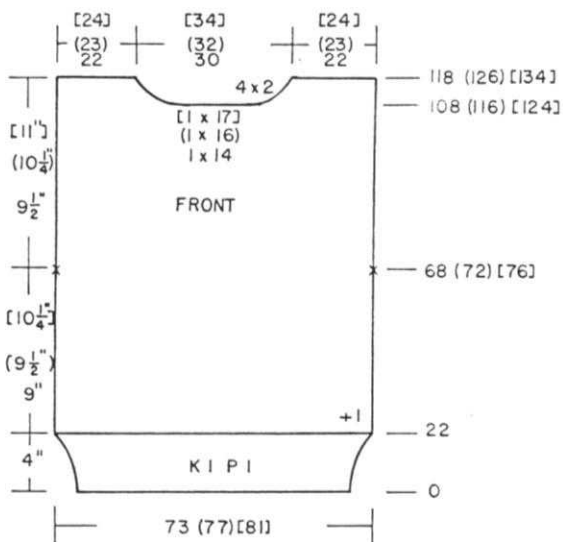
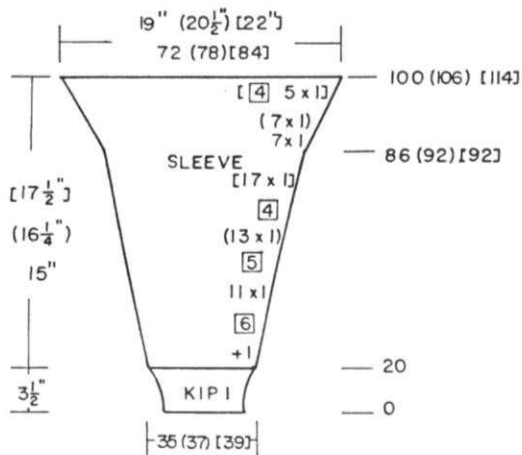

FRONT:

Cast on 73 (77) [81] sts. and work 22 rows K1, P1 Ribbing. Transfer the ribber sts. to main machine and increase 1 st. on the right side. Continue in Stockinette stitch. After Row 68 (72) [76], mark each side with bit of contrast yarn for setting in sleeves. After Row 108 (116) [124], bind off the center 14 (16) [17] sts. put the needles on the left into holding position and complete the right side first. *ON NECK SIDE, bind off 2 sts. 4x then knit to Row 118 (126) [134] and bind off the remaining sts. (or remove the sts. onto waste yarn. Bring the needles on the left into working position, knit 1 row to the left side, turn the Row Counter back to 108 (116) [124] and complete the left half. Follow the instructions from *.

BACK:

Work the back the same as the front BUT OMIT THE NECK SHAPING. Be sure to mark each side after Row 68 (72) [76] for setting in sleeves. After Row 118 (126) [134], bind off each section separately for shoulders and neck (or you can remove them onto waste yarn).

SLEEVES:

Cast on 35 (37) [39] sts and work 20 rows K1, P1 Ribbing. Transfer the ribber sts. to main machine and increase 1 st. on the right side. ON EACH SIDE, increase 1 st. every 6th row 11x. (every 5th row 13x) [every 4th row 17x]. After Row 86 (92) [92], increase 1 st. every 2nd row 7x (7x) [1 st. every 4th row 7x].

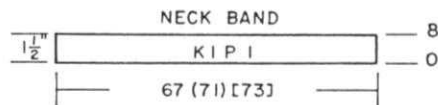

NECKBAND:

Sew 1 shoulder first. Cast on 67 (71) [73] sts. and work 8 rows K1, P1 Ribbing. Transfer the ribber sts. to main machine then hang the neck onto these needles, spacing them evenly around. Knit 1 row from left to right then bind off the crochet method holding the yarn in back of the gate pegs.

FINISHING: See General Instructions. Sew sleeves in place to the marked edges of front and back.



WOMAN'S STRIPED PULLOVER

SIZES: 6/8 (10/12) [14/16]
YARN: Multi-Show
GRAMS:
 color 1 250 300 350
 color 2 200 250 300
TENSION: 7.1
GAUGE: 7 1/2 sts. 10 1/2 rows =
 2" (5 cm)

Make on the 230 BULKY or any Bulky machine.
 Stockinette stitch with color stripes. Bands are K1, P1 Ribbing with tension 4/3.

FRONT:

Cast on 73 (77) [81] sts. with color 1 and work 22 rows K1, P1 Ribbing. Transfer the ribber sts. to main machine and increase 1 st. on the right side. Continue in Stockinette stitch with color stripes of 16 (18) [18] rows of each color as shown on the chart. After Row 68 (72) [76], mark each side for setting in sleeves. Knit to Row 108 (116) [124]. Bind off the center 14 (16) [17] sts., put the needles on the left into holding position and complete the right side first.
 *ON NECK SIDE, bind off 2 sts. 4x. After Row 118 (126) [134] bind off the remaining sts. Bring the needles on the left into working position, knit 1 row to the left side, turn the Row Counter back to 108 (116) [124] and complete the left half. Follow the instructions from *.

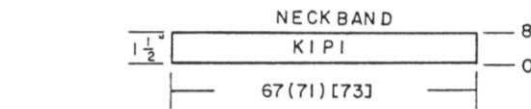

NECKBAND:

Sew 1 shoulder first. Cast on 67 (71) [73] sts. with color 1 and work 8 rows K1, P1 Ribbing. Transfer the ribber sts. to main machine then hang the neck with wrong side facing you onto the machine. Knit 1 row left to right then bind off the crochet method with yarn held in back of the gate pegs.

SLEEVES:

With color 1, cast on 35 (37) [39] sts. and work 20 rows K1, P1 Ribbing. Transfer the ribber sts. to machine and increase 1 st. on the right side. Continue in Color stripes and stockinette stitch same as for front and back and AT THE SAME TIME, ON EACH SIDE, increase 1 st. every 6th row 11x (every 5th row 13x) [every 4th row 17x]. After Row 86 (92) [92] ON EACH SIDE, increase 1 st. every 2nd row 7x. (every 2nd row 7x). [every 4th row 5x]. After Row 100 (106) [114] bind off LOOSELY.

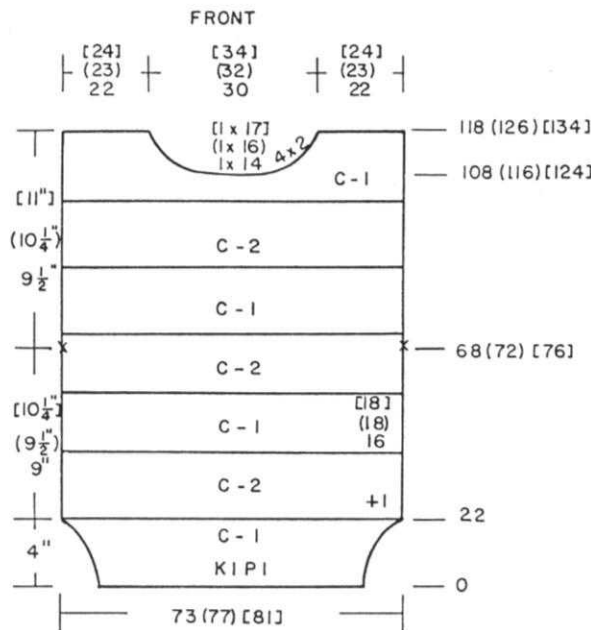

BACK:

Work the back the same as the front (Omit the neck shaping) and after Row 118 (126) [134] Bind off each section separately. 22 (23) [24] sts. for each shoulder and 30 (32) [34] sts. for neck.

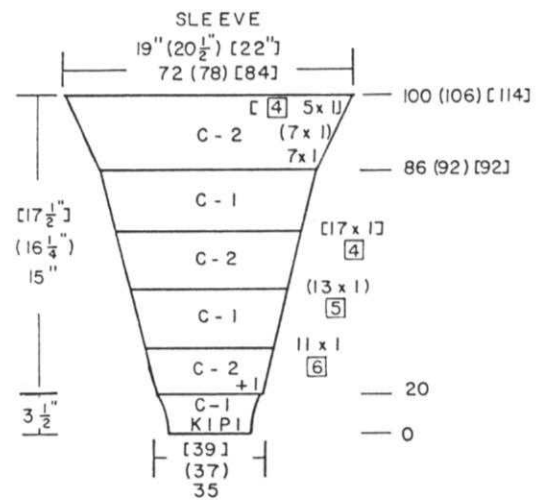
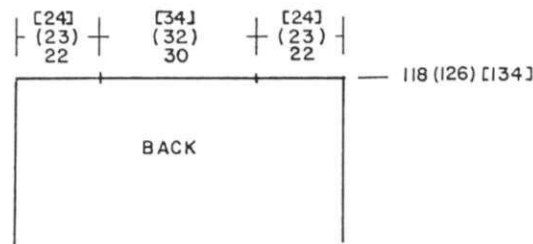

FINISHING: See General Instructions. Sew sleeves in place at marked edges of front and back.



MAN'S FAIR ISLE PULLOVER

SIZES: 36/38 (40/42)
 YARN: Vienna
 GRAMS:
 color 1 500 550
 color 2 100 100
 TENSION: 5.1 to 6
 GAUGE: 16 sts, 22 rows = 2" (5 cm)

Stockinette stitch with Fair Isle
 Design. Punch Card. Bands are
 K1, P1 Ribbing with Tension
 3/3 II

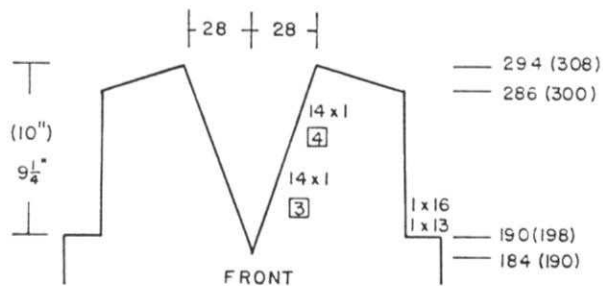
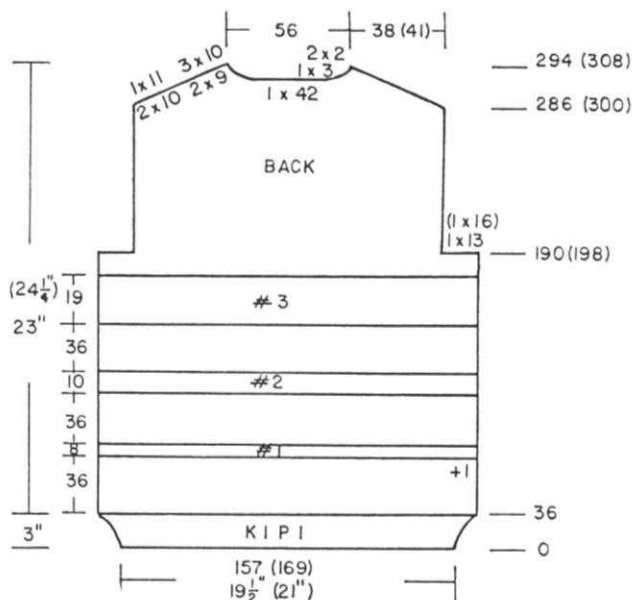

FRONT:

Work the front the same as the back to Row 184 (190). Divide in the center, put the needles on the left into holding position and complete the right side first. *ON NECK SIDE, using the FULL FASHION METHOD, decrease 1 st. every 3rd row 14x, then 1 st. every 4th row 1 st. 14x AND AT THE SAME TIME, after Row 286 (300), SHAPE SHOULDER same as the back. Bring the needles on the left into working position, knit 1 row to the left side, turn the Row Counter back to 184 (190) and complete the left half. Follow the instructions from *.

BACK:

With color 1, cast on 157 (169) sts. and work 36 rows K1, P1 Ribbing. Transfer the ribber sts. to main machine and increase 1 st. on the right side. Continue in Stockinette stitch to Row 72, setting Pattern 1 after Row 71. Continue in Pattern as follows:
 8 Rows Pattern 1.
 35 rows Stockinette stitch then set Pattern 2 on Next Row. Work 10 rows in Pattern. Work 35 rows Stockinette stitch then Set Pattern No. 3 on next Knit as follows:

3 rows color 1 and color 2
 Release color 2 from feeder but do not cut yarn.
 4 rows color 1
 5 rows color 1 and color 2
 Release color 2 as before.
 4 rows color 1
 3 rows color 1 and color 2
 Release color 2 and break yarn. (Total 19 rows in Pattern)
 Continue in Stockinette stitch with color 1.
 After Row 190 (198) SHAPE ARMHOLE: ON EACH SIDE, bind off 13 sts. 1x, (16 sts. 1x).
 After Row 286 (300), SHAPE SHOULDER: Bind off 10 sts. 2x, 9 sts. 2x (11 sts. 1x, 10 sts. 3x).
 After Row 294 (308), bind off the remaining sts.

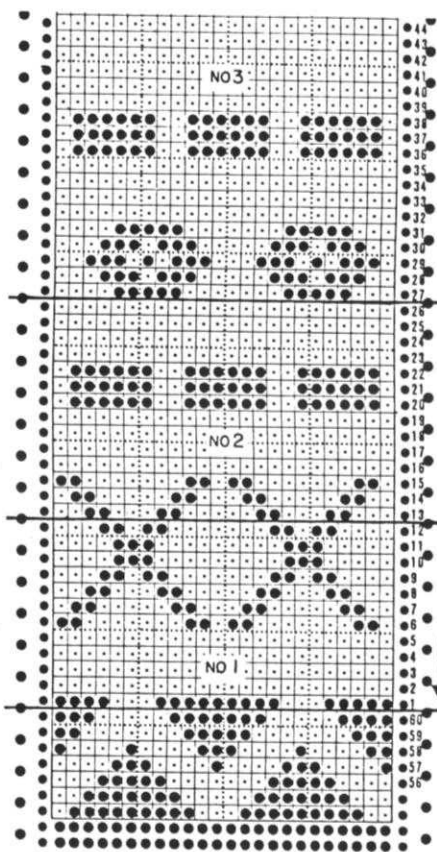
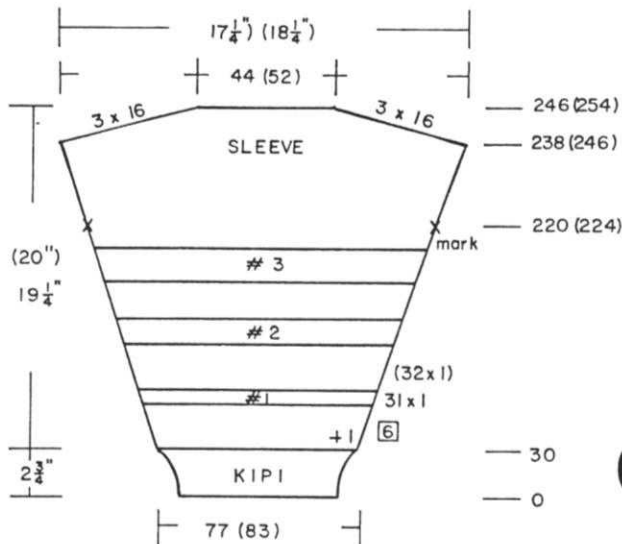

SLEEVES: Make 2.

Cast on 77 (83) sts. and work K1, P1 Ribbing. Transfer the ribber sts. to main machine and work in Pattern same as the back. Inc. 1 st. AT THE SAME TIME, increase 1 st. every 6th row 31x (32x) ON EACH SIDE, AND AT THE SAME TIME, mark EACH EDGE after Row 220 (224). After Row 238 (246), ON EACH SIDE, bind off (or you can use Short Rows) 16 sts. 3x. After Row 246 (254), bind off (or remove onto waste yarn) the remaining sts.

Continued

NECKBANDS:

Close left shoulder first. Cast on 135 (141) sts. with color 1 and work K1, P1 Ribbing, Tension 3/3 II.

Work 6 rows Tension 3.1 II for both beds.

Work 6 rows 3.2 both beds.
8 rows 4 both beds.

AT THE SAME TIME, ON THE RIGHT, increase 1 st. EVERY ROW 18x. Transfer the ribber sts. to main machine. With wrong side facing you, hang 56 sts. from back neck and the remaining sts. from front neck edge onto sts. on machine. Knit 1 row from left to right then bind off the crochet method using yarn held behind the gate pegs.

LEFT NECK BAND

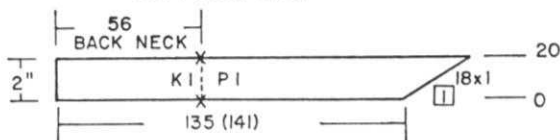

Work the right neckband in the same way over 79 (85) sts. but increase on the LEFT side.

RIGHT NECK BAND

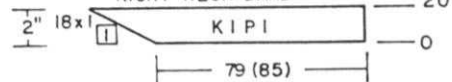

FINISHING: See General Instructions.

406



WOMAN'S STRIPED JACKET & TOP

SIZES: 6/8 (10/12) [14/16]
YARN: Cordella
GRAMS:
color 1 300 350 350
color 2 200 250 250
TENSION: 7 to 8 - Rib. 5/5 II
GAUGE: 14 sts. 20 rows = 2" (5 cm)

The Top is Stockinette stitch with color stripes. Waistband is K1, P1 Ribbing. Crochet around armholes and neckline.

The Jacket is knitted on the KII 881 using the KG 88 ELECTRIC CARRIAGE. It is in GARTER STITCH with COLOR STRIPES. Punch Card.

SLEEVELESS TOP BACK:

With color 1, cast on 123 (133) [145] sts. and work 32 rows K1, P1 Ribbing. Transfer the ribber sts. to main machine and increase 1 st. on the right side.

Continue in Stockinette stitch with color stripes of 6 rows color 2, 6 rows color 1.

After Row 144 (152) [160], SHAPE ARMHOLE: ON EACH SIDE, bind off 2 sts. 1x, 1 st. 4x.

Knit to Row 216 (228) [240]. Bind off the center 46 (48) [50] sts., put the needles on the left into holding position and complete the right side first.

*SHAPE SHOULDER: Bind off 9 sts. 2x, 8 sts. 2x (10 sts. 2x, 9 sts. 2x) [11 sts. 2x, 10 sts. 2x].

Bring the needles on the left into working position, knit 1 row to the left side, turn the Row Counter back to 216 (228) [240] and complete the left half. Follow the instructions from *.

SLEEVELESS TOP FRONT:

Work the front the same as the back to Row 170 (182) [194]. Bind off the center 40 (42) [44] sts., put the needles on the left into holding position and complete the right side first.

*ON NECK SIDE, decrease 1 st. every 18th row 3x.

After Row 224 (236) [248], SHAPE SHOULDER same as the back.

Bring the needles on the left into working position, knit 1 row to the left side, turn the Row Counter back to 170 (182) [194] and complete the left half. Follow the instructions from *.

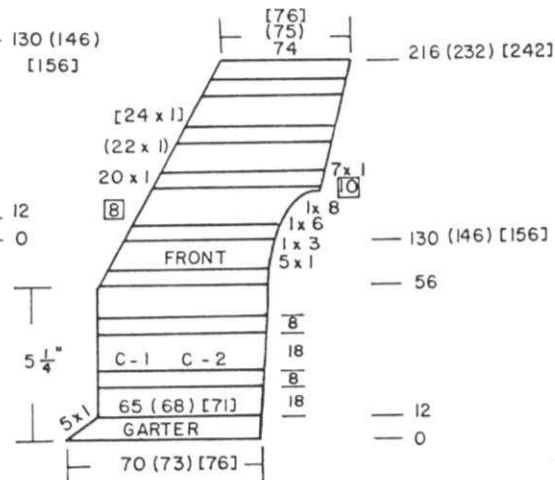
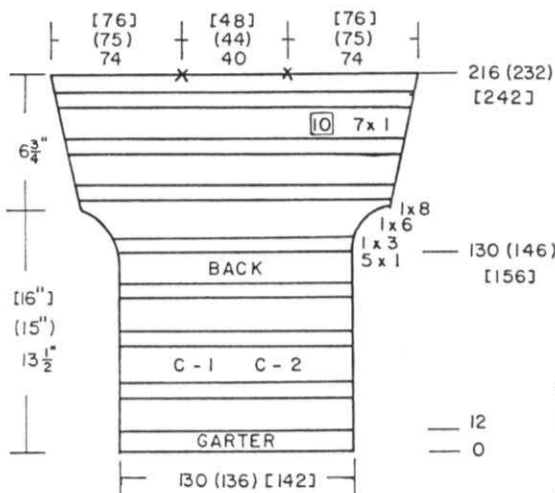

JACKET BACK:

Punch Card for Pattern and use Card No. 2 (comes with Carriage) for GARTER STITCH.

With color 1, 'e' cast on LOOSELY in the hooks of needles - 130 (136) [142] sts. Set KG 88 CARRIAGE (See Instruction Manual).

Set Punch Card No. 2. Knit 12 rows GARTER STITCH. Set Card for Pattern (card you punched).

* Knit 2 rows color 2
2 rows color 1

REPEAT 3 times.

Knit 2 rows color 2
8 rows color 1 *

REPEAT FROM * TO *.
After Row 130 (146) [156], ON EACH SIDE, increase 1 st. 5x, 3 sts. 1x, 6 sts. 1x, 8 sts. 1x.

ON EACH SIDE, increase 1 st. every 10th row 7x.

After Row 216 (232) [244]

Remove the KG 88 Carriage from the machine and put regular carriage onto machine.

With contrast waste yarn, knit over the 74 sts. for each shoulder and use a separate waste yarn for the 40 (44) [48] sts. for neck. Knit at least 2" of waste knitting for each section. Remove from machine.

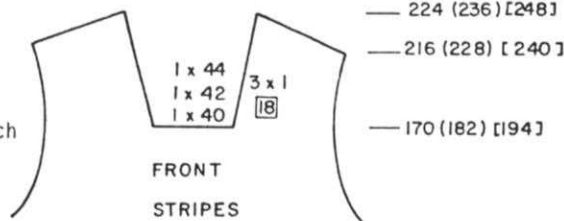
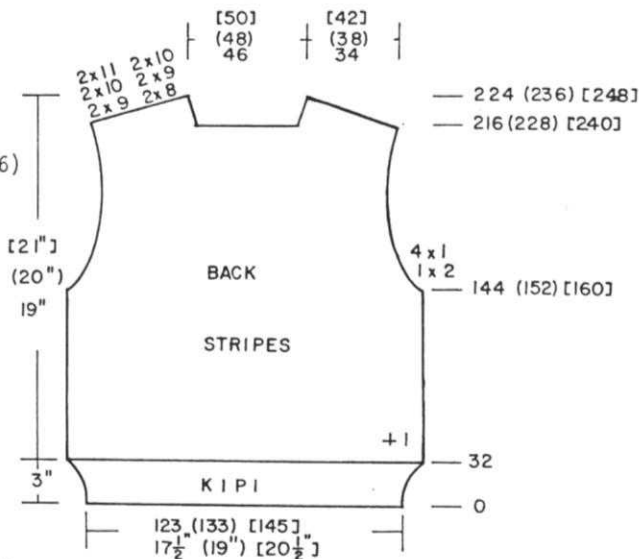

JACKET FRONT: Make 1, reverse 1.

Cast on for GARTER STITCH same as you did for back. 70 (73) [76] sts. Work 12 rows GARTER STITCH AND AT THE SAME TIME, on the LEFT (right for 2nd section) decrease 1 st. every 2nd row 5x.

SET PUNCH CARD NO. 1 and work in color stripes same as for back. After Row 56, SHAPE NECK ON THE LEFT (right). Decrease 1 st. every 8th row 20x (22x) [24x] AND AT THE SAME TIME, after Row 130 (146) [156], SHAPE ARM-HOLE AND SLEEVE same as the back. After Row 216 (232) [242], remove KG 88 Carriage from machine and replace with regular carriage. With contrast waste yarn, knit 10 or 12 rows stockinette stitch then remove the work from the machine.

BEFORE KNITTING THE BANDS, CLOSE SHOULDERS as follows: Hang one back shoulder with right side facing you onto machine, then hang front shoulder with wrong side facing you onto same needles with the stitches IN THE HOOKS of needles (back shoulder sts. in back of latches). Pull the front stitches through the back stitches. Knit 1 loose row then bind off the crochet method. REPEAT for other side.

SLEEVE BANDS: Make 2.

With KG 88 CARRIAGE on machine, 'e' cast on 100 sts. Knit 12 rows GARTER STITCH. Replace KG Carriage with regular carriage. Hang the sleeve edge evenly onto these needles, knit 1 loose row then bind off.

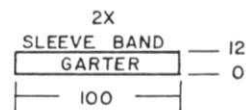

FRONT AND BACK NECK BANDS Make 2.

With KG 88 CARRIAGE on machine, 'e' cast on 144 (150) 156] sts. Knit 12 rows GARTER STITCH AND AT THE SAME TIME, on the RIGHT (left) decrease 1 st. every 2nd row 5x.

Replace KG 88 Carriage with regular Carriage.

With wrong side facing you, hang front of garment onto these needle having 20 (22) [24] sts. from shoulder to center back. Knit 1 loose row then bind off.

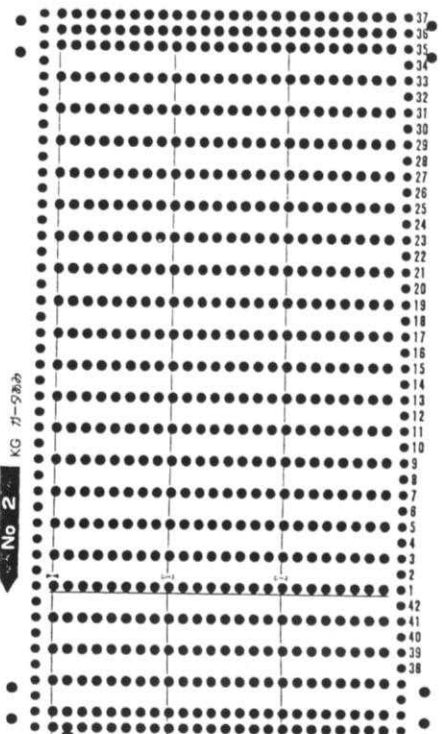
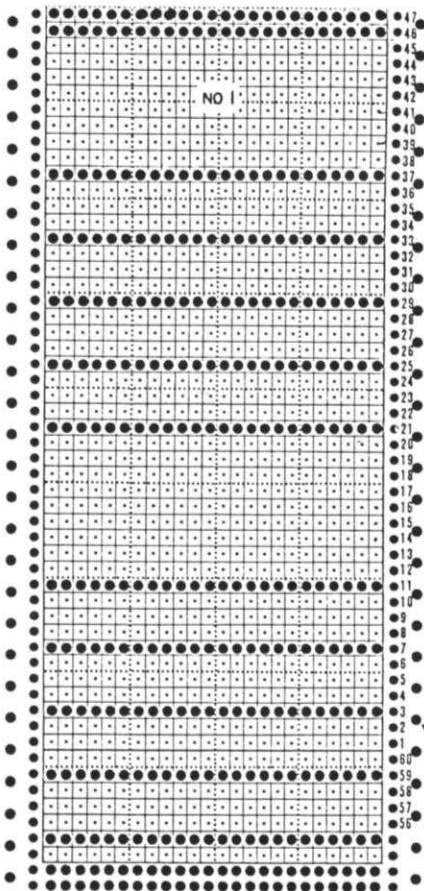
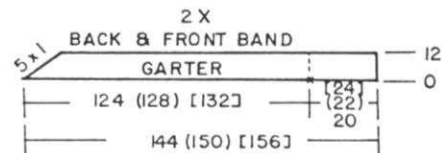

FINISHING: See General Instructions. For Sleeveless Top, work 1 row single crochet then 1 row reverse single crochet working backwards around neck and armhole edges.

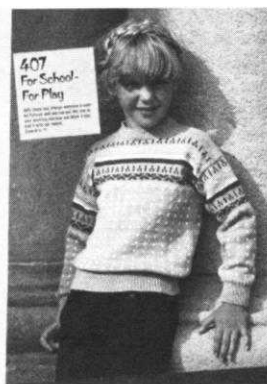

GIRL'S PULLOVER

SIZES: 8/9 (10/11)
YARN: Amore
GRAMS:
 color 1 250 300
 color 2 50 50
 color 3 50 50
 color 4 50 50
 color 5 50 50
TENSION: 7
GAUGE: 16 sts. 20 rows = 2" (5 cm)

Stockinette stitch with Norwegian Designs. Punch Cards. Bands are K1, P1 Ribbing with Tension 3/3 II.

BACK:

Cast on 115 (127) sts. with color 1 and work 20 rows K1, P1 Ribbing with Tension as given above.
 Transfer the ribber sts. to main machine and continue with CARD #1. Increase 1 st. on the right side. After Row 114 (132), Work CARD #2 and after Row 120 (132) mark each side with bit of contrast yarn for setting in sleeves.
 After Row 176 (192), SHAPE SHOULDER: ON EACH SIDE, bind off 12 sts. 3x (13 sts. 3x)
 After Row 180 (198) bind off (or remove onto contrast waste yarn) the remaining sts.

FRONT:

Work the front the same as the back to Row 162 (180). Bind off the center 22 (28) sts. for neck. Put the needles on the left into holding position and complete the right side first.
 *ON NECK SIDE, bind off 2 sts. 3x, 1 st. 5x.
 After Row 176 (192) SHAPE SHOULDER: Bind off 12 sts. 3x (13 sts. 3x).
 Bring the needles on the left into working position, Knit in Pattern to the left side, turn the Row Counter back to 162 (180) and complete the left half. Follow the instructions from *.

FINISHING: See General Instructions. Sew sleeves in place at marked edges.

SLEEVES:

Cast on 71 sts. with color 1 and work 20 rows K1, P1 Ribbing. Transfer the ribber sts. to main machine and increase 1 st. on the right side.
 Continue with CARD #1.
 ON EACH SIDE, increase 1 st. every 12th row 9x (every 10th row 12x)
 BUT AT THE SAME TIME, after Row 76 (88) Work CARD #2.
 After Row 124 (136), bind off (or remove onto waste yarn) the remaining sts.

NECKBAND:

Close 1 shoulder first. Cast on 143 (161) sts. with color 1 and work 10 rows K1, P1 Ribbing. Transfer the ribber sts. to main machine, then pick up the sts. around neck and hang them onto same needles.
 Knit 1 row from left to right then bind off the crochet method with yarn held behind the gate pegs.

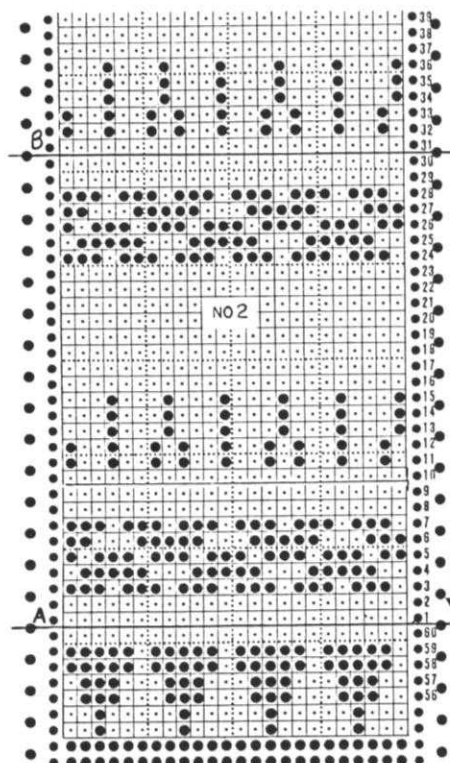
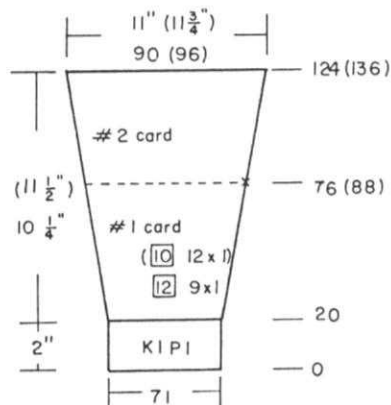
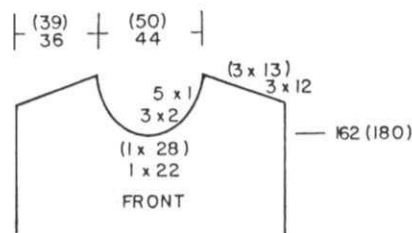
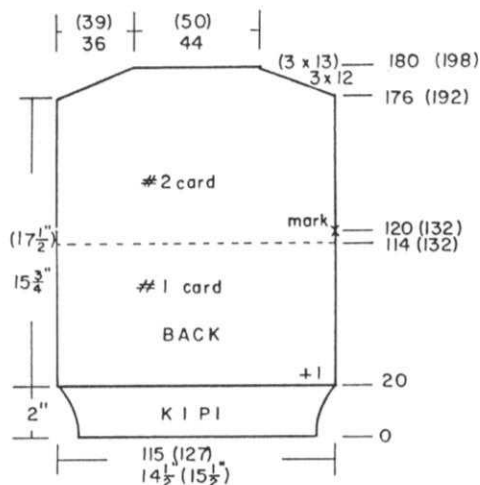
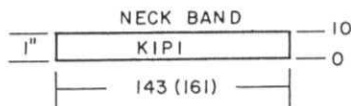

SET PATTERN A

CARD # 2	A FEEDER	B FEEDER
6 Rows	Color 1 -	Color 3
3 "	" 1	" 4
5 "	" 1	" 5
3 "	" 1	" 5
5 "	" 1	" 5
2 "	" 1	" 5

RELEASE KC

2 Rows EACH COLORS 5, 4, 3, 2, 1

SET PATTERN B

5 Rows	Color 1	Color 3
3 "	" 1	" 4
5 "	" 1	" 4

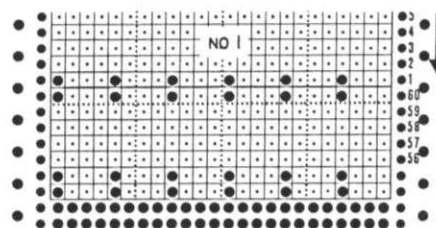

*2 Rows Color 1 - Color 2
 4 " " 1
 REPEAT FROM *.



WOMAN'S LONG PULLOVER (or Mini Dress)

SIZES: 6/8 (10/12) [14/16]
 YARN: Vienna
 GRAMS: 550 600 650
 TENSION: 5/5 II - Fishermans Rib
 GAUGE: 16 sts.30 rows = 2" (5 cm)

Fishermans Rib with bands in K1,
 P1 Ribbing with Tension 4/3 II.

BACK:

Cast on 147 (157) [169] sts.
 and work K1, P1 Ribbing to
 Row 16.

Set your machine for Fishermans
 Rib with Tension 5/5 II.

Knit to Row 328 (342) [356].
 SHAPE ARMHOLE: ON EACH SIDE,
 bind off 4 (5) [6] sts. 1x,
 2 sts. 3x, 1 st. 5x.

After Row 456 (474) [492],
 transfer the ribber sts. to
 main machine, then separately
 bind off 38 (41) [45] sts. for
 each shoulder and 41 (43) [45]
 sts. for neck.

FRONT:

Work the front the same as the
 back to Row 328 (342) [356].
 Divide in the center. Put
 the needles on the left into
 holding position and complete
 the right side first.

*SHAPE ARMHOLE SAME AS THE

BACK AND ON NECK SIDE,
 Decrease 1 st. every 6th row
 21x (22x) [23x].

After Row 456 (474) [492],
 transfer the ribber sts. to
 main machine then bind off.
 Bring the needles on the left
 into working position AND BE
 SURE TO PLACE THE STS. IN
 THE HOOKS OF THE NEEDLES.

Knit 1 row to the left, turn
 the Row Counter back to 328
 (342) [356] and complete the
 left half. Follow instructions
 from * BUT CHANGE THE NECK
 SHAPING TO - decrease 1
 st. on neck side every 6th
 row 20x (21x) [22x].

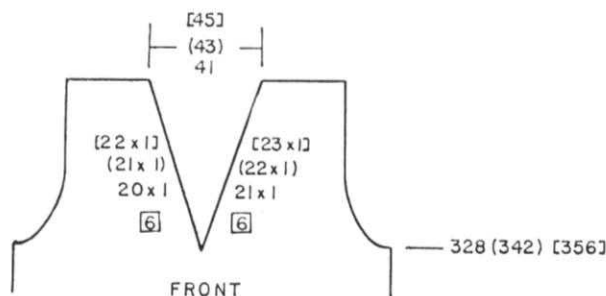
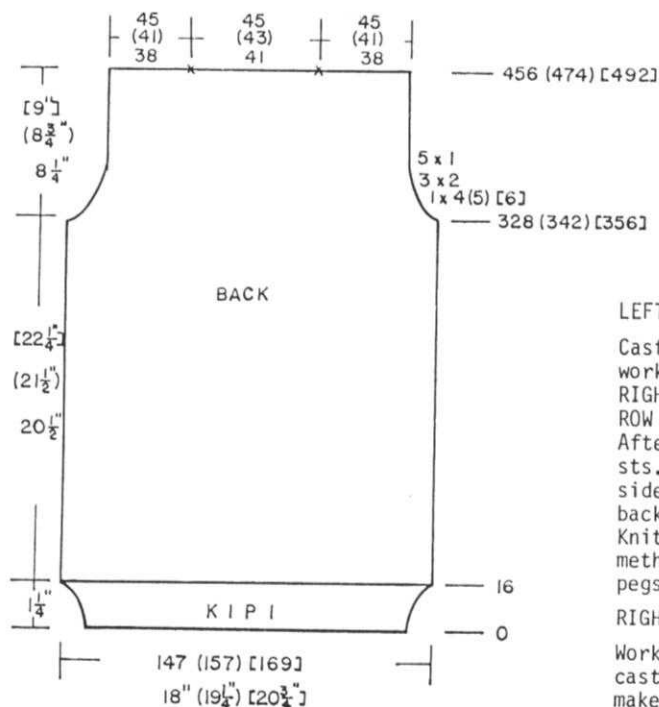

SLEEVES: Make 1, reverse 1.

Cast on 65 (69) [73] sts. and
 work 24 rows K1, P1 Ribbing. Ten.4/3 II.

Set machine for Fishermans Rib and
 be sure to change tension to 5/5 II.
 ON EACH SIDE, increase 1 st. every
 10th row 18x (19x) [20x].

After Row 216 (226) [236] SHAPE CAP:
 ON EACH SIDE, make the bind offs
 and decreases as shown on the Chart
 following the instructions for YOUR
 SIZE.

After Row 306 (324) [342], knit to
 Row 378 (400) [426] ON THE RIGHT SIDE
 ONLY (left for 2nd sleeve) bind off
 5 sts. 1x, 2 sts. 3x, 1 st. 4x.

After Row 418 (442) [470], transfer
 the ribber sts. to main machine and
 bind off.

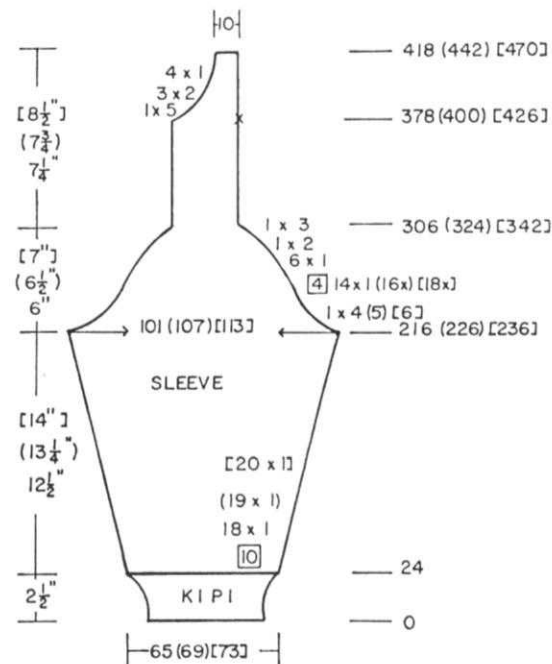

LEFT NECKBAND: Close left shoulder.

Cast on 145 (151) [157] sts. and
 work K1, P1 Ribbing and ON THE
 RIGHT SIDE, increase 1 st. EVERY
 ROW 16x.

After Row 18, transfer the ribber
 sts. to main machine then with wrong
 side facing you, pick up sts. across
 back neck then down front (evenly).
 Knit 1 row then bind off the crochet
 method with yarn held behind the gate
 pegs.

RIGHT NECKBAND:

Work the same as the left band but
 cast on 75 (79) [83] sts. and
 make the increases on the LEFT.

FINISHING: See General Instructions.

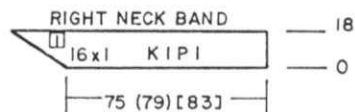
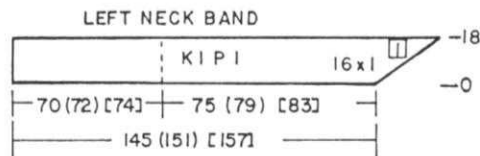



WOMAN'S PULLOVER

SIZES: 6/8 (10/12) [14/16]
YARN: Cordella
GRAMS: 250 300 350
TENSION: 7 to 8
GAUGE: 13 sts. 19 rows = 2" (5 cm)

Stockinette stitch with an EYELET DESIGN for Ribbon insertion. Punch Card. You will need 3 yds each of 3 colors of Ribbon in 1/4" OR 3/8" width, plus matching Embroidery Floss to make circles (see picture). Bands are K1, P1 Ribbing with Tension 5/4 II.

FRONT:

Cast on 111 (121) [131] sts. and work 42 rows K1, P1 Ribbing. Transfer the ribber sts. to main machine and increase 1 st. on the right side. Continue in Stockinette stitch to Row 102 (112) [122]. Begin the Eyelet Design, following the instructions as given along side the Punch Card drawing. After Row 132 (138) [144], SHAPE ARMHOLE: ON EACH SIDE, bind off 5 sts. 1x, 3 sts. 2x, 2 sts. 1x, 1 st. 5x. After Row 188 (198) [208] SHPE NECK: Bind off the center 14 (16) [18] sts. Put the left side needles into A Position with a Ravel Cord and complete the right side first. MARK CARD. *ON NECK SIDE, bind off 4 sts. 1x, 3 sts. 1x, 2 sts. 3x, 1 st. 2x (3x) [4x] AND AT THE SAME TIME, after Row 204 (214) [224], SHAPE SHOULDER: Bind off 5 sts. 3x, 6 sts. 1x. (6 sts. 4x) [6 sts. 1x, 7 sts. 3x]. Bring the needles on the left back to working position and complete the left half. Follow the instructions from *. Set Card back to marked row.

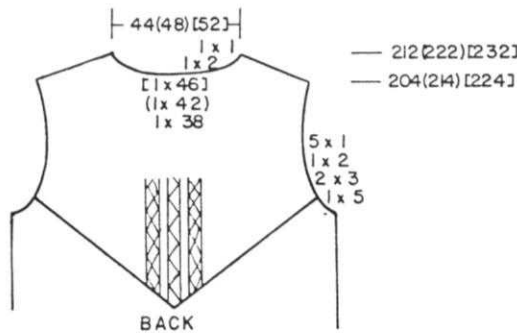
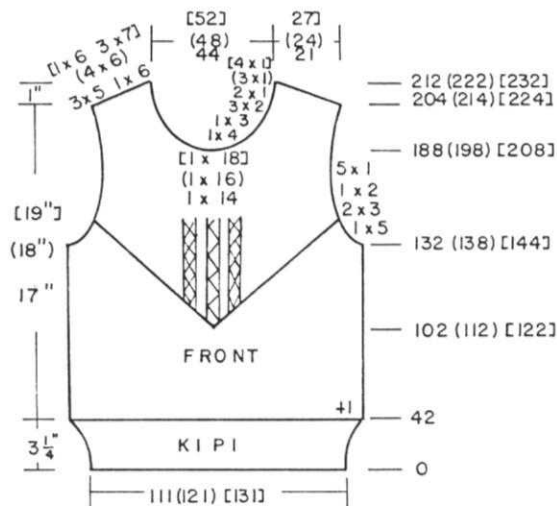
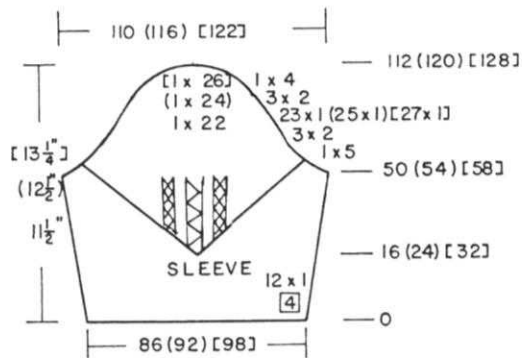

BACK:

Work the back the same as the front to Row 204 (214) [224]. MARK CARD. Bind off the center 38 (42) [46] sts. put the needles on the left into holding position and complete the right side first. (same as before). *SHAPE NECK AND SHOULDER AT THE SAME TIME. ON NECK SIDE, bind off 2 sts. 1x, 1 st. 1x. FOR SHOULDER, bind off same as you did for front. Bring the needles on the left into working position and complete the left half. Set Card back to marked row and follow the instructions from *.

SLEEVES:

OPEN CAST ON with waste yarn 86 (92) [98] sts. Knit 9 to 11 rows, then 1 row Ravel cord to the right side. Counter at 0, change to garment yarn and continue in Stockinette stitch to Row 16 (24) [32] but AT THE SAME TIME, ON EACH SIDE, increase 1 st. every 4th row 12x and begin EYELET DESIGN same as the front and back after Row 16 (24) [32]. After Row 50 (54) [58], continue in Eyelet Design, SHAPE ARMHOLE: ON EACH SIDE, bind off 5 sts. 1x, 2 sts. 3x, 1 st. 23x (25x) [27x], then bind off 2 sts. 3x, 4 sts. 1x. After Row 112 (120) [128], bind off the remaining sts.

SLEEVE BANDS.

Cast on 63 (67) [73] sts. and work 16 rows K1, P1 Ribbing. Transfer the ribber sts. to main machine, then hang the open sts. from sleeve edge onto these needles DOUBLING EVERY 3rd stitch (3rd and 4th sts. on one needle). Bring all the needles into holding position (to make it easy for you to knit the next row) Knit 1 row then bind off the crochet method holding yarn behind the gate pegs.

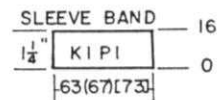

FINISHING: See General Instructions. With right side facing you, work slip stitch crochet around neckline, then with wrong side facing you, work 3 to 5 more rows slip stitch crochet going into back of stitch only. Work embroidery in a circle around lower edge of eyelets in same colors as ribbons as shown in picture. Insert ribbons as shown.

Continued

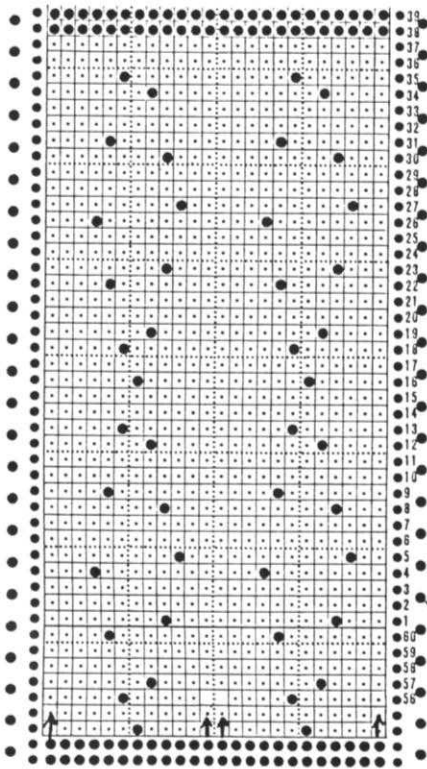

Mark the needlebed with a China marking pencil or crayon as follows:
 Mark 2 needles each side of 0.
 *Skip 10 needles then mark next 2 needles ON EACH SIDE.
 REPEAT FROM * across.

SINGLE EYELET WITH NEEDLE OUT OF WORK

Transfer st. on left of 0 to the left.
 Transfer st. on right of 0 to the same needle on the left (3 sts. on 1 needle). 2 empty needles. Bring empty needle on the left into working position, empty needle on the right to A (out of work) position.

** Lace Carriage left to right. Leave only 2 center selected needles in Pattern. Return all other selected needles to working position.
 Lace Carriage to the left. Knit 2 rows.
 *Lace Carriage 4x. Leave only 2 center selected needles in Pattern, return all others to working position. Knit 2 rows.

Continue in this way 1 more time. (6 rows of actual knitting). Transfer stitch on the left of empty needle to the next working needle on the right. Bring empty needle on the right into working position. REPEAT FROM * 3x.
 Transfer st. on the right of empty needle to the next working needle on the left. Bring left empty needle into working position..
 ON EACH SIDE, make next SINGLE EYELETS over marked needles as you did in FIRST PARAGRAPH. REPEAT FROM ** TO ** 6x.
 Add 1 more Pattern on each side. REPEAT FROM BEGINNING (4 Patterns across center).

Continue in Pattern as established but after EACH 12 ROWS of actual knitting, you must add another SINGLE EYELET ON EACH SIDE and on the following 12 rows, begin another DIAMOND ON EACH SIDE.

410



PULLOVER BACK

With color 2, cast on 127 (139) [153] sts. Work K1, P1 Ribbing. Knit 4 rows color 2, 28 rows color 1. Transfer the ribber sts. to main machine and continue in Stockinette stitch. Increase 1 st. on the right side. Knit to Row 144 (150) [156].
SHAPE ARMHOLE: ON EACH SIDE, bind off
 4 sts. 1x, 2 sts. 3x.
 1 st. every 4th row 4x (2x) [4x].
 After Row 220 (230) [240], bind off the center 34 (36) [40] sts. put the needles on the left into holding position and complete the right side first.
 *SHAPE SHOULDER AND NECK AT THE SAME TIME.

ON NECK SIDE, bind off 3 sts. 1x, 2 sts. 1x.
 FOR SHOULDER, bind off 7 sts. 4x (8 sts. 3x, 7 sts. 1x) [9 sts. 2x, 8 sts. 2x].
 Bring the needles on the left into working position, knit 1 row to the left side, turn the Row Counter back to 220 (230) [240] and complete the left half. Follow the instructions from *.

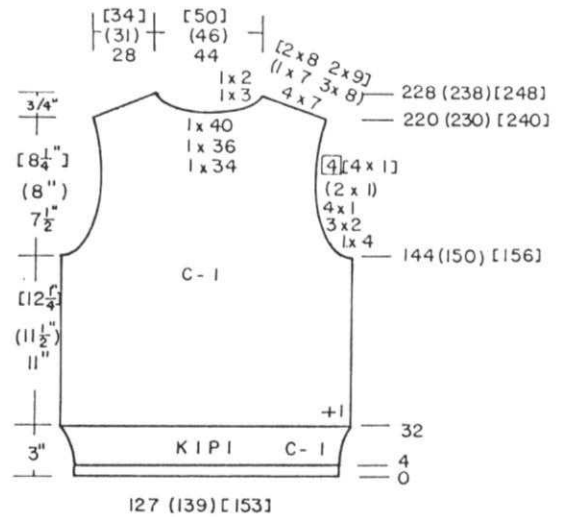
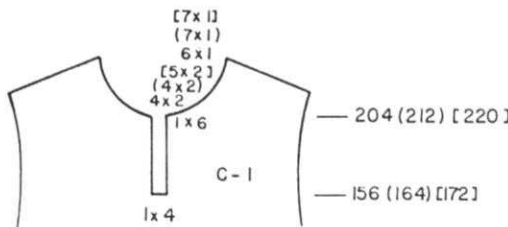

WOMAN'S TWO PIECE DRESS

SIZES: 6/8 (10/12) [14/16]
YARN: Vienna
GRAMS:
 color 1 650 700 800
 color 2 50 50 50
TENSION: 6 to 7 (Stockinette)
GAUGE: 14 sts. 20 rows = 2" (5 cm)
 in Stockinette stitch
SKIRT: Watch for changes in Tensions.

The top is Stockinette stitch with sleeve and lower band in K1, P1 Ribbing. Tie is Stockinette stitch. The skirt is K1, P3 with changes in Tension as given in Instructions. Skirt band is knitted over every other needle.

FRONT:

Work the front the same as the back to Row 156 (164) [172].
 Remove the center 4 sts onto a stitch holder. Put the needles on the left into holding position and complete the right side first.
 *Knit to Row 204 (212) [220].
 ON NECK SIDE, bind off 6 sts. 1x for all sizes, then bind off 2 sts. 4x (4x) [5x] then 1 st. 6x (7x) [7x].
 AT THE SAME TIME, after Row 220 (230) [240], SHAPE SHOULDER SAME AS THE BACK.
 Bring the needles on the left into working position, knit 1 row to the left side, turn the Row Counter back to 156 (164) [172] and complete the left half. Follow the instructions from *.

Continued

SLEEVES:

With color 2, cast on 73 (77) [81] sts. and work K1, P1 Ribbing. 4 rows with color 2 then change to color 1 to Row 24. Transfer the ribber sts. to main machine and increase 1 st. on the right side. Continue in Stockinette stitch with color 1. ON EACH SIDE, increase 1 st. every 12th row 13x (14x) [15x]. After Row 166 (176) [182], SHAPE CAP: ON EACH SIDE, bind off 5 sts. 1x, 3 sts. 2x, 2 sts. 3x then decrease 1 st. ON EACH SIDE, very 2nd row 14x (15x) [16x], then ON EACH SIDE, bind off 2 sts. 3x (4x) [3x] then 3 sts. 2x (4 sts. 1x) [3 sts. 1x] then for last size only, 4 sts. 1x. After Row 216 (228) [236], bind off the remaining sts.

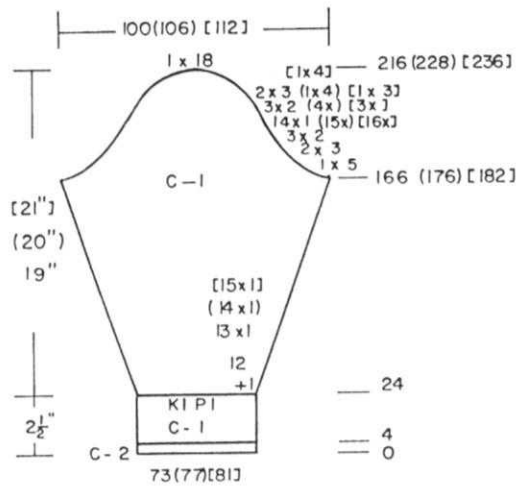

TIE: Make 2.

With contrast waste yarn, cast on 10 sts. Knit in Stockinette stitch. After knitting 9 to 11 rows, knit 1 row to the right with a Ravel Cord. Change to garment yarn, color 1 and put Counter at 0. After Row 48, ON EACH SIDE, increase 1 st. every 4th row 8x, every 6th row 6x. After Row 124, WORK SHORT ROWS: Bring into holding position, 2 sts. 7x ON EACH SIDE. Bring all the needles back into working position before knitting the next 2 rows. Change to color 2 and knit 10 rows over all needles. Pick up the first row of color 2 and hang hem then bind off LOOSELY.

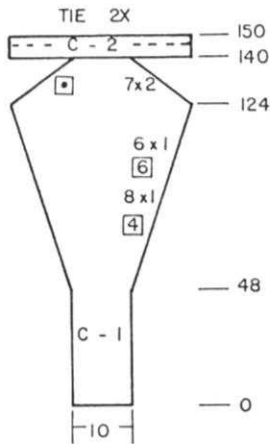

TIE EDGE BAND: Make 4x.

With wrong side facing you, pick up 90 sts. from edge of tie and with color 2, knit 10 rows Stockinette stitch. Hang the hem and bind off. Make another band for this side, then 2 bands of other side of Tie.

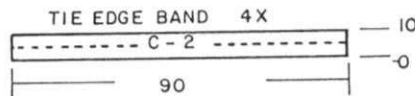

FRONT OPENING BAND;

With wrong side facing you, pick up 72 sts. around the front neck opening. With color 2, knit 10 rows. Hang hem and bind off.

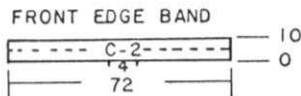

NECK BAND:

Close both shoulders first. With contrast waste yarn, cast on 100 (106) [112] sts. After knitting 9 to 11 rows, knit 1 row with ravel cord to the right side. Change to color 1 and put Counter at 0. Work Stockinette stitch. 6 rows Tension 7, 6 rows Tension 6, 8 rows Tension 5, 6 rows Tension 6, 6 Rows Tension 7, Remove onto waste yarn and sew in place, 1 edge to the inside, 1 to the outside of neck edge.

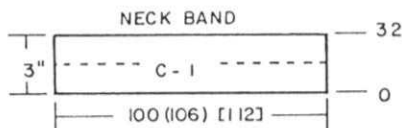

SKIRT: Make 2 sections the same.

Cast on 197 sts. for K1, P1 Ribbing. Tension 0/0 II. After the 3 circular rows, transfer the main machine sts. as shown on the Chart. 3 sts. on the Ribber, 1 st. on the knitter. Set main machine Carriage for Slip (or Skip) stitch in ONE DIRECTION ONLY. KNITTING machines, push in the LEFT PART BUTTON. Tension 8/8 I - Knit to Row 130 (140) [150]. Tension 7/7 I - 20 Rows, Tension 6/6 I - 20 Rows, Tension 5/5 I - 20 Rows, Tension 4/4 I - 20 Rows. After Row 210 (220) [230] Transfer all Ribber sts. to the main machine. Transfer every other st. to the neighboring needles (you can use your Lace Carriage if you like). Leave empty needles OUT OF WORK. RELEASE CONTROL FOR SLIP (or Skip). With Tension 4, knit 12 rows. Bring empty needles into working position, knit 1 row over all needles, then bind off LOOSELY.

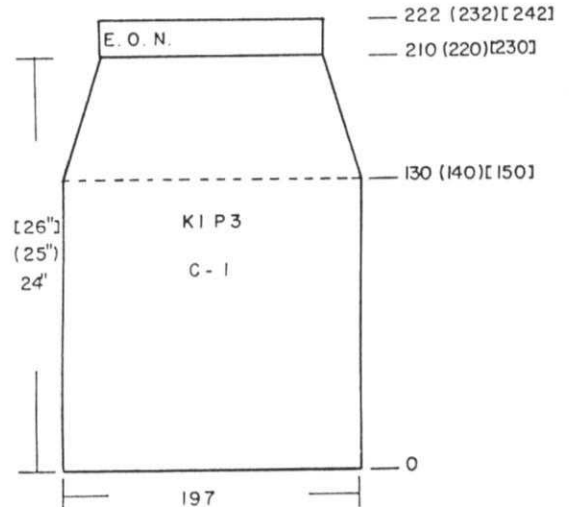

FINISHING: See General Instructions. Turn skirt waistband over to the wrong side and sew down in place. Close back seam of Tie with overcast stitch, keeping seam as flat as possible. Sew Tie to front edges of Neckband.

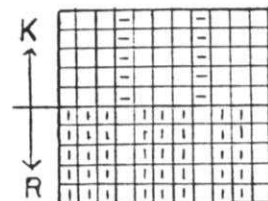



FRONT BANDS: Make 2.

Make FRONT BANDS the same as Neckband, casting on 187 (193) [199] sts.

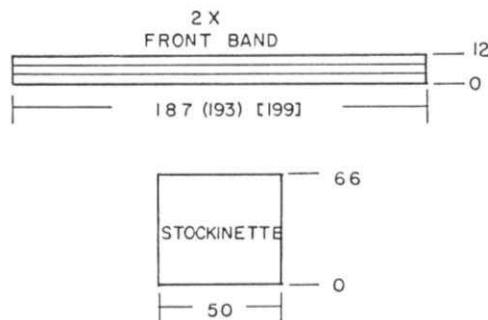

FRONT: Make 1, reverse 1.

MAKE POCKET LININGS FIRST. Make 2.

Cast on 50 sts. with color 1 and work Stockinette stitch with Tension 5, Knit to Row 66 then remove the sts. onto contrast waste yarn.

LEFT FRONT: With color 1, cast on 83 (89) [95] sts. and work in Rib Pattern same as Back.

After Row 60, leave 12 (16) [20] sts. on the LEFT (right for second section) then transfer the following Ribber sts. (TO MAKE UP 50 STS.) to the main machine. Remove the 50 sts. onto contrast waste yarn. With knit side facing you, hang the pocket lining onto the empty needles. Remove waste yarn then transfer the required sts. for Pattern onto the Ribber needles.

Continue in Pattern to Row 145 (151) [159].

SHAPE ARMHOLE: Bind off 6 sts. 1x, 4 sts. 1x, 3 sts. 1x, 1 st. 10x.

After Row 208 (214) [222], SHAPE

NECK: Bind off

4 (5) [6] sts. 1x, 3 sts. 1x,

2 sts. 4x, 1 sts. 6x (9x) [12x].

After Row 233 (243) [255], SHAPE

SHOULDER same as the back.

MAKE RIGHT FRONT WITH REVERSE

SHAPING.

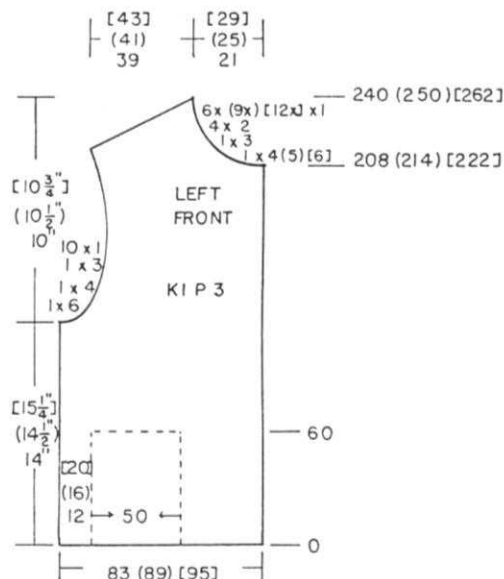
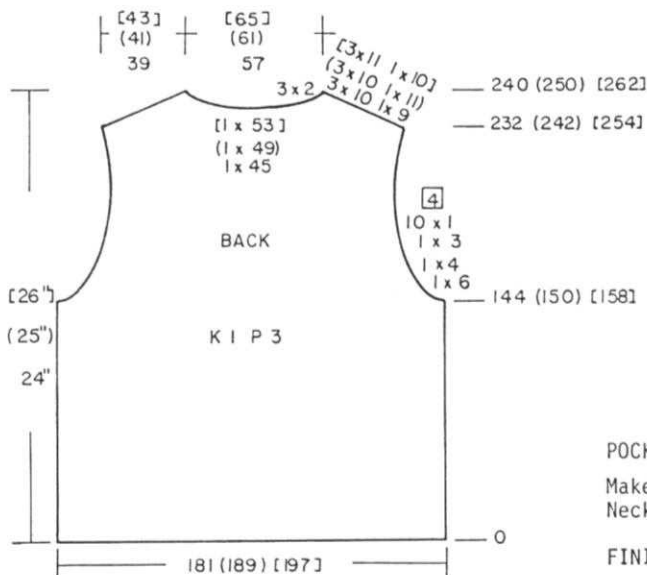

NECKBAND: Sew shoulders first.

With color 1, cast on 139 (149) [159] sts. and work K1, P1 Ribbing with color changes as follows:

Use Tension 1/1 II for the 3 circular cast on rows and set machine for knitting 1 row on the main machine and 2 on the Ribber.

After the cast on rows, change to Tension 5/4 II and work

2 rows color 1

2 rows color 2

2 rows color 1

2 rows color 2

4 rows color 1

Transfer the ribber sts. to main machine then with wrong side facing you, hang the neck edge onto the needles. Knit 1 row LOOSE TENSION then bind off.

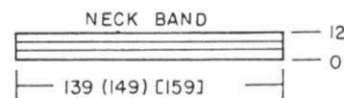

ARMHOLE BAND: Make 2.

Make ARMHOLE BANDS the same as Neckband, casting on 173 (181) [191] sts.

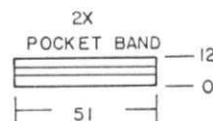
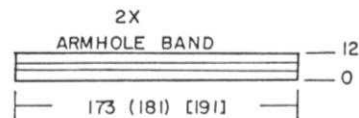

POCKET BANDS: Make 2.

Make POCKET BANDS the same as Neckband, casting on 51 sts.

FINISHING: See General Instructions.

WOMAN'S VEST AND SKIRT

SIZES: 6/8 (10/12) [14/16]

YARN: Vienna

GRAMS for VEST

color 1 300 300 350

color 2 50 50 50

GRAMS for SKIRT

color 1 350 400 450

RIBBER TENSION for K1/P3 6/6 I

RIBBER TENSION for K1, P1 BANDS 5/4 II

THE VEST INSTRUCTIONS are given. Please use the SKIRT INSTRUCTIONS from PATTERN No. 410.

BACK:

With color 1, cast on 181, (189) [197] sts. and work the 3 rows of circular knitting the same as you did for SKIRT PATTERN No. 410.

SET INTO PATTERN same as for Skirt, K1/P3 and Tension 6/6 I-Knit in Pattern to Row 144 (150) [158].

SHAPE ARMHOLE: ON EACH SIDE, bind off

6 sts. 1x, 4 sts. 1x, 3 sts. 1x,

1 st. every 4th row 10x.

Knit to Row 232 (242) [254].

Bind off the center 45 (49) [53]

sts for neck. Put the

needles on the left into holding

position and complete the right

side first.

*SHAPE SHOULDER AND NECK AT

THE SAME TIME.

FOR NECK, bind off 2 sts. 3x.

FOR SHOULDER, bind off

9 sts. 1x, 10 sts. 3x.

(11 sts. 1x, 10 sts. 3x).

[10 sts. 1x, 11 sts. 3x].

Bring the needles on the left

into working position, (BE SURE

THEY ARE SET CORRECTLY IN PATTERN)

knit 1 row to the left side, turn

the Row Counter back to 232 (242)

[254] and complete the left half.

Follow the instructions from * ,



MAN'S PULLOVER

SIZES: 36/38 (40/42)
YARN: Extra

GRAMS:
color 1 600 600
color 2 200 200
color 3 50 50
color 4 50 50

TENSION: 10+ Rib. 9 or 10

GAUGE: 12 sts. 16 rows = 2" (5 cm)

This is a Special Pullover made on the KH 881 using the KG 88 ELECTRIC CARRIAGE. It is a true SEED STITCH Pattern and if you want to make the Pullover without the ELECTRIC CARRIAGE, you will need to use a simulated Seed Stitch to show on the knit side. Punch Card or use similar card from the original set that came with your machine. Bands are K1, P1 Ribbing.

NOTE: - After the Ribbing, ALL COLOR 1 sections as shown on the Charts for FRONT AND BACK are SEED STITCH. For the SLEEVES, ALL COLOR 1 and 2 are SEED STITCH. The other colors are all Stockinette stitch.

FRONT:

Make Waistband first. Cast on 124 (136) sts. with color 1 and work 30 rows K1, P1 Ribbing. Knit 1 row Stockinette stitch then remove the sts. onto contrast waste yarn.

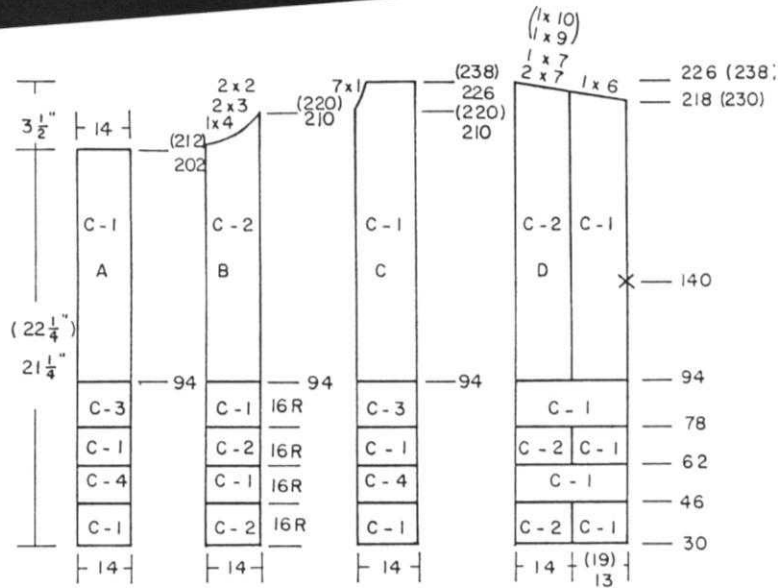
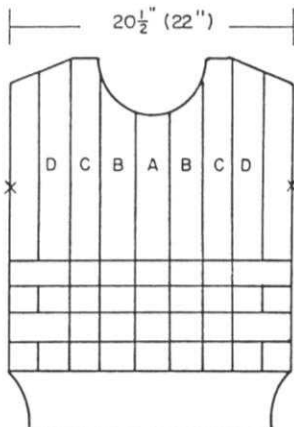

SECTION - D

Hang 13 (19) sts. on the right of band back onto the machine. Counter at 30. Color 1 Knit 16 rows Seed Stitch. Remove onto contrast waste yarn. Hang the next 14 sts. onto the machine. Counter at 30.

With color 2, knit 16 rows Stockinette stitch. Leave the sts. on the machine and hang the 13 (19) sts. (held on waste) back onto the machine to the RIGHT of those already there. With color 1, work 16 rows Seed Stitch. Remove 14 sts. on the left onto waste yarn. Counter at 62. work 16 rows Seed Stitch with color 1 then remove the sts. onto waste yarn.

Pick up the left 14 sts. and hang them back onto machine. Counter 62. Work 16 rows Stockinette stitch with color 2. Hang the right 13 (19) sts. back onto machine, Counter 78 and work 16 rows Seed Stitch with color 1.

Remove the left 14 sts. onto waste yarn and work Seed Stitch with color 1 over the right 13 (19) sts. (Counter 94).

Work in Seed Stitch to Row 140 then mark edge with bit of contrast yarn. Continue in Seed Stitch to Row 218 (230). Bind off 6 sts. 1x, 7 sts. 1x. (9 sts. 1x, 10 sts. 1x). Pick up the 14 sts. on left. Counter at 94. Knit in Stockinette stitch with color 2 to Row 222 (234) then bind off 7 sts. 2x.

FRONT - C - B - A

C - Pick up the next 14 sts. from waistband - to the left of Section D. FOLLOW THE CHART and complete C Section. Pick up the next 14 sts. and complete B section as shown. Pick up the next 14 sts. for A Section and complete as shown. NOW WORK BACKWARDS. Pick up 14 sts. and work B section and be sure to REVERSE the shaping at neck edge. Pick up 14 sts. and work C section with reverse shaping. WORK D SECTION as you did before BUT BE SURE TO REVERSE THE COLORS AND THE SHOULDER SHAPING.

BACK:

Work the back the same as the front EXCEPT FOR NECK SHAPING. Follow the Chart.

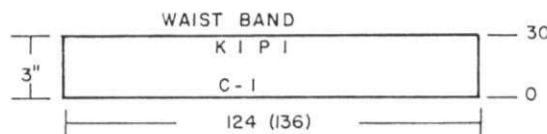
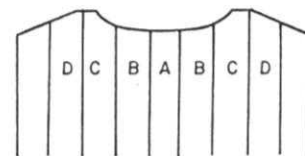
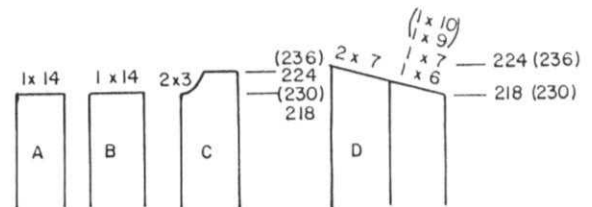

SLEEVES:

OPEN CAST ON with contrast waste yarn - 76 sts. After knitting 9 to 11 rows, knit 1 row with Ravel Cord to the right side. Put Counter at 0 and with color 1, knit Seed Stitch. ON EACH SIDE, increase 1 st. every 4th row 25x. After Row 102, remove the sts. onto waste yarn. Hang the first 14 sts. on the right, that are held on waste yarn back onto the machine. With color 2, work 16 rows Seed Stitch. Remove onto waste yarn. Continue in this way, each time picking up 14 sts. and knitting 16 rows (SEE CHART). Remember that all color 1 and 2 are Seed Stitch). When you have completed the sections across, hang ALL SECTIONS back onto the machine as shown on the Chart. Put Counter at 118. With color 1, knit to Row 128. ON EACH SIDE, BIND OFF 8 sts 6x. After Row 140, bind off the remaining sts.

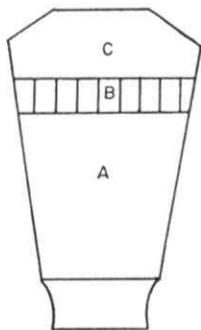
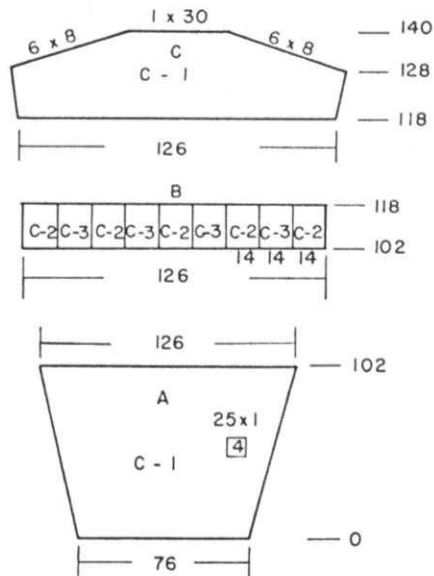

NECKBAND:

Close right shoulder first. Cast on 130 sts. with color 1 and work 50 rows K1, P1 Ribbing. Hang the sts. from neck edge evenly across. Knit 1 loose row then bind off.

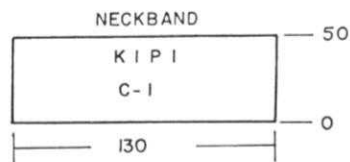

SLEEVE BAND:

Cast on 56 sts. with color 1 and work 26 rows K1, P1 Ribbing. Hang the sts. from sleeve that are held on waste yarn, doubling up every 3rd and 4th st. together. Knit 1 LOOSE ROW, then bind off.

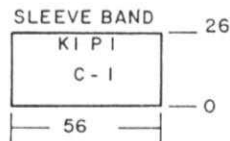

FINISHING: See General Instructions. Sew all loose sections together. You may carefully overcast the edges, or you can weave them from the right side, picking up the very edge stitch.

413



Stockinette stitch with an INTARSIA DESIGN. Use INTARSIA CARRIAGE and be sure to practice on a sample first to be certain that you are holding the yarn so that the stitch and row gauge agrees with the stitch and row gauge when the yarn is fed through the feeder. Bands are K1, P1 Ribbing using Tension 6/6 I

WOMAN'S PULLOVER

SIZES: 6/8 (10/12) [14/16]
 YARN: Alanda
 GRAMS:
 color 1 250 250 300
 color 2 200 200 200
 color 3 100 100 100
 TENSION: 9 to 10
 GAUGE: 12 sts. 19 rows = 2" (5 cm)

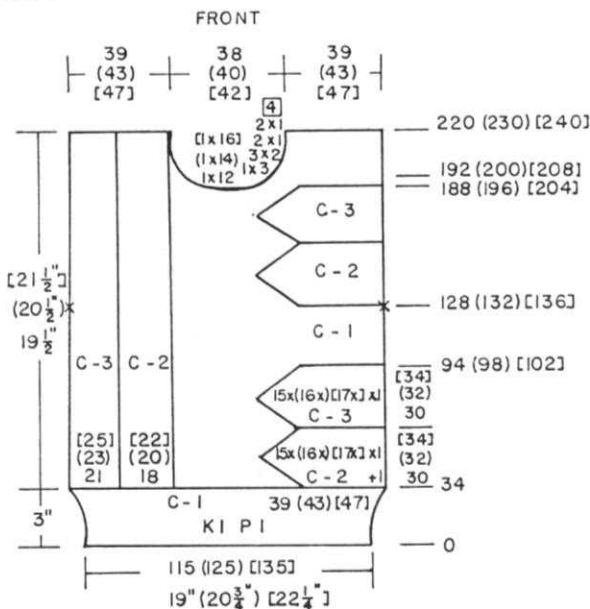

FRONT:

Cast on 115 (125) [135] sts. with color 1 and work 34 rows K1, P1 Ribbing (see tension above). Transfer the ribber sts. to main machine and begin the INTARSIA DESIGN. Follow the Line Drawing for changes in color and the shaping. Increase 1 st. on the right. After Row 128 (132) [136], mark each side with a bit of contrast yarn for setting in sleeves. Continue with the Intarsia Design. After Row 192 (200) [232] bind off the center 12 (14) [16] sts. for neck, put the needles on the left into holding position and complete the right side first. *ON NECK SIDE, bind off 3 sts. 1x, 2 sts. 3x, 1 st. 2x, 1 st. every 4th row 2x. After Row 220 (230) [240], bind off the remaining sts. Bring the needles on the left into working position, knit 1 row to the left, then turn the Row Counter back to 192 (200) [204] and complete the left half. Follow the instructions from *.

Continued

BACK:

Work the back the same as the front BUT REVERSE THE SIDES FOR THE INTARSIA DESIGN. After Row 212 (222) [232], bind off the center 20 (22) [24] sts. for neck. Put the needles on the left into holding position and complete the right side first. *ON NECK SIDE, bind off 3 sts. 3x. After Row 220 (230) [240], bind off the remaining sts. Bring the needles on the left into working position, knit 1 row to the left side, turn the Row Counter back to 212 (222) [232] and complete the left half. Follow the instructions from *.

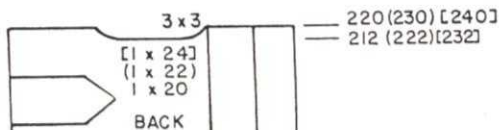

NECKBAND: Sew 1 shoulder first.

Cast on 113 (119) [125] sts. with color 1 and work 12 rows K1, P1 Ribbing. Transfer the ribber sts. to main machine, then pick up the sts. around neckline EVENLY. Knit 1 row then bind off the crochet method holding yarn in back of gate pegs.

FINISHING: See General Instructions.

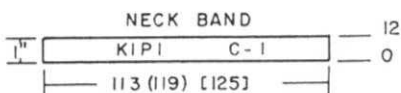

SLEEVES:

OPEN CAST ON with contrast waste yarn. 74 (80) [86] sts. Knit 9 to 11 rows then 1 row with Ravel Cord to the right side. Counter at 0, change to Color 2. Work Stockinette stitch with color stripes. There are 32 (34) [36] rows each of color 2, color 3, color 1 then 38 (40) [42] rows color 2 (see chart BUT AT THE SAME TIME, ON EACH SIDE, increase 1 st. every 8th row 4x, every 5th row 19x. After Row 134 (142) [150], bind off the remaining sts.

SLEEVE BANDS:

Cast on 49 (53) [57] sts. with color 1 and work 34 rows K1, P1 Ribbing. Transfer the ribber sts. to main machine, then hang the open sts. of sleeve held on waste yarn onto these sts., doubling up every 2nd stitch.

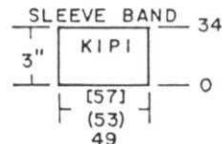
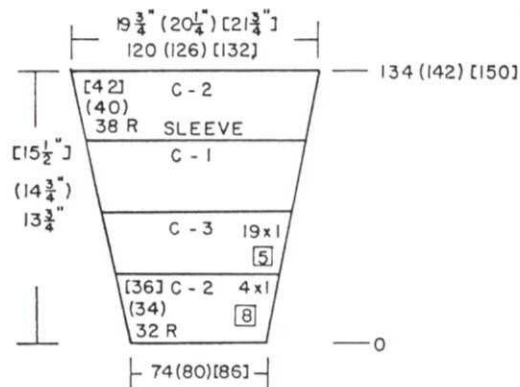

LEGWARMERS - Color 1

You will need 150 grams extra of Alanda to knit the Legwarmers.

Cast on 67 sts. with color 1 and work 16 rows K1, P1 Ribbing with same tension as garment. Transfer the ribber sts. to main machine and continue in Stockinette stitch. ON EACH SIDE, increase 1 st. every 30th row 6x. After Row 206, transfer every other stitch to the Ribber and work K1, P1 Ribbing to Row 218. Knit 1 row with Ravel Cord then 12 rows waste knitting. Move the carriage across without yarn to drop the sts. from the machine. To bind off the open sts. use a strand of yarn and work as follows with a crochet hook. Work a slip stitch through the open sts. going into a knit stitch (as it faces you) from the front and going into a purl stitch from the BACK. Close back seam.

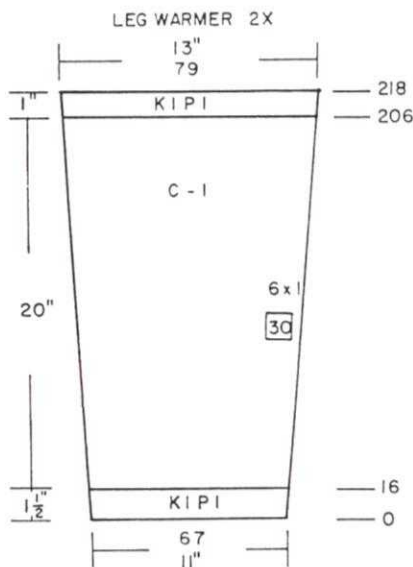

KNITTING BINDERS

Holds Two Complete Volumes

Keep all your KNITTING Magazines together and build a beautiful library of Patterns.

● **PRICE: \$6.95**

California residents please add Sales Tax.

Shipping costs \$1.25 (Canada and all other countries \$2.75)

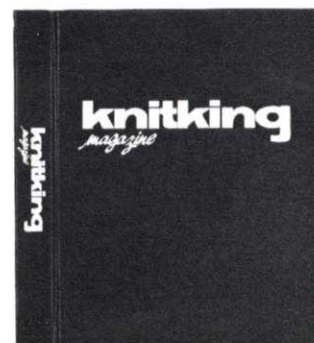



WOMAN'S STRIPED PULLOVER

SIZES: 6/8 (10/12) [14/16]

YARN: See Below

COLORS & GRAMS:

Color 1 - Regia	200	250	250
Color 2 - Regia	200	250	250
Color 3 - Show	50	50	50
Color 4 - Beatrice Silver	50	50	50

TENSION: 7 to 8 - Rib 5/4 II

GAUGE: 14 sts., 20 rows = 2" (5 cm)

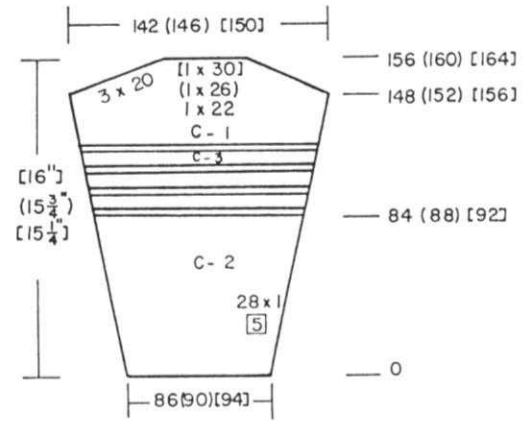

SLEEVES:

OPEN CAST ON with waste yarn. 86 (90) [94] sts. After knitting 9 to 11 rows, knit 1 row with Ravel Cord to the right side. Counter at 0, and continue Stockinette stitch with color 2. ON EACH SIDE, increase 1 st. every 5th row 28x. After Row 84 (88) [92], work the color stripes same as you did before and when completed, continue with color 1. After Row 148 (152) [156] ON EACH SIDE, bind off 20 sts. 3x then bind off the remaining sts.

SLEEVE BAND: Make 2.

Cast on 65 (67) [71] sts. with color 1 and work 34 rows K1, P1 Ribbing. Transfer the ribber sts. to main machine, then hang the sts. from sleeve (held on waste yarn) onto these sts. Hang 2 sts. on every 3rd stitch. Knit 1 very loose row, then bind off.

SLEEVE BAND

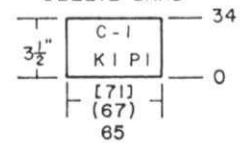

NECKBAND: - Sew center sections and 1 shoulder together.

Bring 110 (114) [118] needles into working position. With RIGHT SIDE FACING YOU, hang neck edge onto these needles, spacing sts. evenly across. Knit 24 rows with color 1 then bind off LOOSELY. Fold band and sew in place.

FINISHING: See General Instructions.

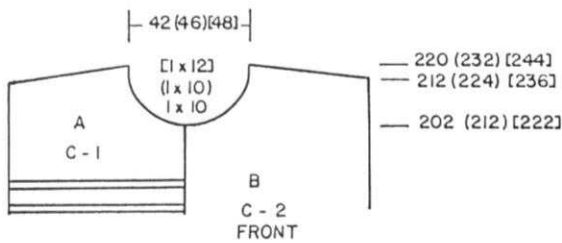
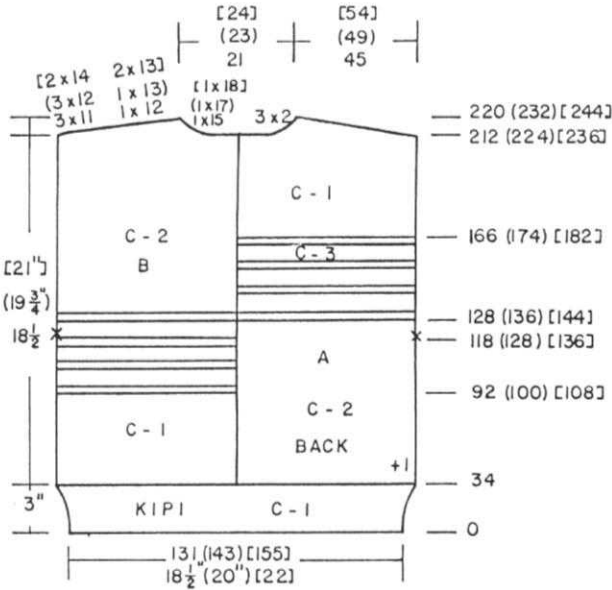
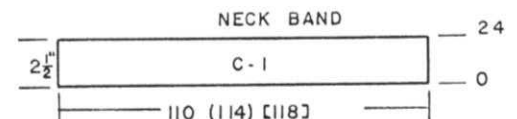

FRONT:

Work the front sections the same as back sections, MATCHING COLOR STRIPES for B FRONT to B BACK section and A to A as shown on the Charts. Mark the rows for setting in Sleeve and SHAPE NECK after Row 202 (212) [222] ON NECK SIDE, bind off 10 (10) [12] sts. 1x, then bind off 3 sts. 1x, 2 sts. 4x (5x) [5x] then 1 st. 5x. AT THE SAME TIME, SHAPE SHOULDER same as the back after Row 212 (224) [236].

The front and back are each made in two sections then put together down the center. Stripes are staggered to form design. Knitted in Stockinette stitch with color stripes as shown. Bands are K1, P1 Ribbing.

BACK:

Cast on 131 (143) [155] with color 1 and work 34 rows K1, P1 Ribbing. Transfer the Ribber sts. to main machine, increase 1 st. on the right side then remove HALF the sts. on the LEFT onto contrast waste yarn. With color 2, continue knitting BACK A SECTION in Stockinette stitch. After Row 118 (128) [136], mark the right edge with bit of yarn for setting in sleeve. After Row 128 (136) [144] work the color stripes of *2 Rows color 4, 10 rows color 3. REPEAT FROM * 2 times more then knit 2 rows color 4. Continue with color 1. After Row 212 (224) [236] SHAPE SHOULDER AND NECK AT THE SAME TIME. FOR SHOULDER, bind off 11 sts. 3x, 12 sts. 1x (12 sts. 3x, 13 sts. 1x) [14 sts. 2x, 13 sts. 2x] FOR NECK, bind off 15 (17) [18] sts. 1x then 2 sts. 3x.

PICK UP THE STS. of band that are held on Waste yarn. Counter 34. BACK SECTION B. With color 1 knit to Row 92 (100) [108]. Work the color stripes same as you did before and mark side edge for sleeve after Row 118 (128) [136]. After the color stripes, continue with color 2. Work the same as for section A, reversing the sides for neck and shoulder shaping.



BACK:

Work the back the same as the front with exception of Neck Shaping. After Row 152, bind off the center 19 (21) sts., put the needles on the left into holding position and complete the right side first. *ON NECK SIDE bind off 3 sts. 2x AND SHAPE SHOULDER AT THE SAME TIME the same as the front. Bring the needles on the left into working position, knit 1 row to the left side, turn the Row Counter back to 152 and complete the left half. Follow the instructions from *.

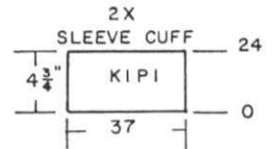
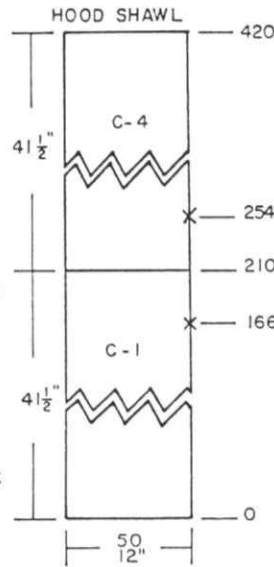
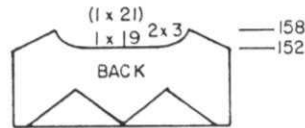

SLEEVE CUFFS: Make 2.

Cast on 37 sts. with color 1 and work 24 rows K1, P1 Ribbing. Transfer the ribber sts. to main machine. Hang the sts. of the sleeve onto these needles with 1 st. on first needle, 2 sts. on next, 1 st. on next, etc. across. Bring all the needles to holding position (be sure holding Cam is set to knit) and knit 1 row. Bind off the crochet method holding the yarn in back of gate pegs to make a loose bind off.

HOODED SHAWL: USE 'e' CAST ON

Cast on 50 sts. with color 1 and work Stockinette stitch to Row 166. Mark edge with bit of contrast yarn. Knit to Row 210. Change to Color 4. Knit to Row 254 and mark edge again. Knit to Row 420. Bind off the crochet method.

WOMAN'S PULLOVER -SHAWL & LEG WARMERS

SIZES: Small Medium/Large
YARN: Multi-Show
GRAMS:
 color 1 400 400
 color 2 150 150
 color 3 100 100
 color 4 100 100
 color 5 100 100

Leg Warmers - Color 2 - 250 gr.
 Hooded Shawl- Color 1 - 200 gr.
 Color 4 - 200 gr.

TENSION: 7 -RIBBER- 3/2
GAUGE: 8 sts. 10 rows = 2" (5 cm)

Made on the KNITKING 230 BULKY machine but can be made on any Bulky machine. Bands are K1, P1 Ribbing. **NOTE:** USE THE INTRASIA METHOD for knitting the ARGYLE DESIGN. You will always decrease (or increase) 1 st. EVERY ROW to form the Design.

FRONT:

Cast on 81 (87) sts. with color 1 and work 12 rows K1, P1 Ribbing (Ten. 3/2). Transfer the ribber sts. to main machine. Change Tension to 7 and work the Argyle Design FOLLOWING THE CHART for changes in color. After Row 108, mark each side with bit of contrast yarn for setting in sleeves. Continue in Argyle Design as shown on the Chart. After Row 142, bind off the center 13 (15) sts. Put the needles on the left into holding position and complete the right side first. *ON NECK SIDE, bind off 3 sts. 1x, 2 sts. 1x, 1 st. 4x AND AFTER ROW 152, SHAPE SHOULDER: Bind off 8 sts. 2x, 9 sts. 1x (9 sts. 3x) Bring the needles on the left into working position, knit 1 row to the left side, turn the Row Counter back to 142 and complete the left half. Follow the instructions from *.

SLEEVES: Make 2.
OPEN CAST ON with contrast waste yarn. 55 sts. After knitting 9 to 11 row, knit 1 row with Ravel Cord to the right side. Put Counter at 0 and follow the Chart for the Argyle Design. ON EACH SIDE, increase 1 st. every 5th row 13x. After Row 62 (66) ON EACH SIDE, bind off 6 sts. 5x. After Row 72 (76), bind off the remaining sts.

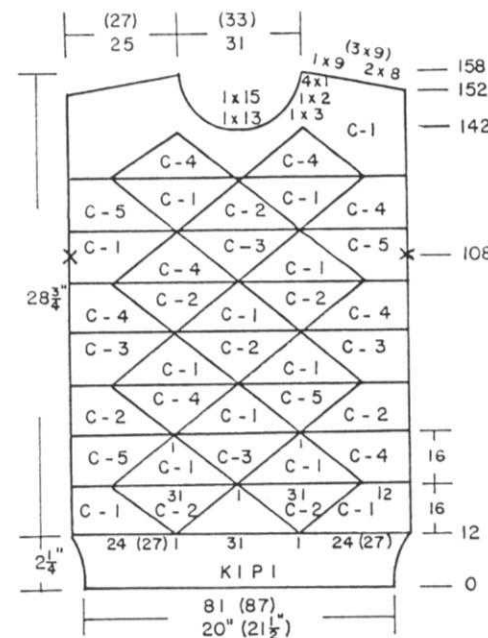
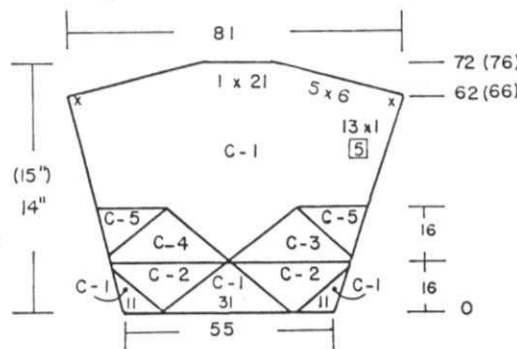

LEG WARMERS

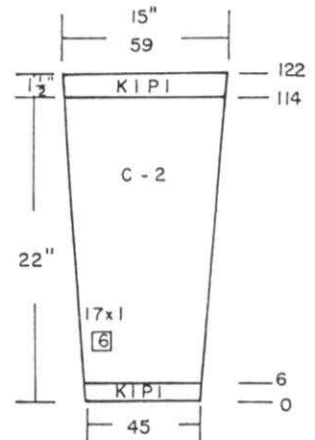

LEG WARMERS: Make 2.

Cast on 45 sts. with color 2 and work 6 row K1, P1 Ribbing. Transfer the ribber sts. to main machine and continue in Stockinette stitch. ON EACH SIDE, increase 1 st. every 6th row 17x. After Row 114, transfer every other stitch to the Ribber and work K1, P1 Ribbing to Row 122. Transfer the ribber sts. to main machine and bind off.

FINISHING: See General Instructions. **HOOD:** Fold hood in center and sew 1 edge from center to marked rows. **LEG WARMERS:** Sew back seams.

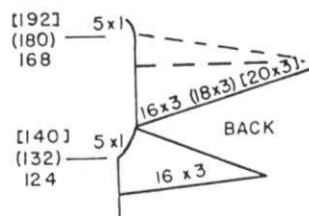

BACK: REVERSE SHAPING.

Work the back the same as the front with reverse shaping, casting on to the LEFT of 0. Work the sleeve increases on the RIGHT and the Intarsia Design and neck shaping on the LEFT.

NECKBAND:

Sew 1 shoulder first. Bring 78 (82) [86] needles into working position. With RIGHT SIDE FACING YOU, hang neck edge onto these needles, spacing sts. evenly across. With color 2, knit 22 rows Stockinette stitch. Bind off LOOSELY. Fold band and sew in place.

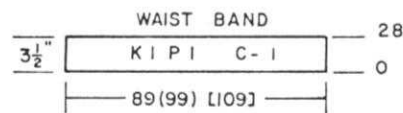
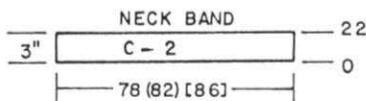

WAISTBAND: Make 2 - Ten. 1/1

Cast on 89 (99) [109] sts. with color 1 and work 28 rows K1, P1 Ribbing (Hold elastic thread by hand in feeder - gently pulling as you knit).

Transfer the ribber sts. to main machine then with wrong side facing you, pick up sts. from waist and hang onto these needles. Knit 1 very LOOSE ROW then bind off loosely.

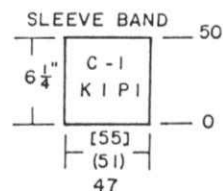

SLEEVE BANDS: Make 2 - Ten 1/1

Cast on 47 (51) [55] sts. with color 1 and work 50 rows K1, P1 Ribbing with elastic as you did for waistband. Transfer the ribber sts. to main machine then with wrong side facing you, hang the open sts. from sleeve onto these needles, doubling the sts. as needed.

Knit 1 very LOOSE row then bind off LOOSELY.

FINISHING: See General Instructions.

WOMAN'S PULLOVER

SIZES: 6/8 (10/12) [14/16]
YARN: SHOW = color 1 (2 strands)
CAPRICCIO = color 2 (2 strands)

GRAMS:
color 1 350 350 400
color 2 80 80 80
TENSION: 0 to 1 -Rib 1/1 (use elastic thread with Ribbing.)
GAUGE: 10 sts. 14 rows = 2" (5 cm)

MADE ON THE KH 230 BULKY or any BULKY MACHINE with Ribber. INTARSIA METHOD using 2 strands of each yarn. Knitted sideways on the machine. Waistband is K1, P1 Ribbing. Neckband is Stockinette stitch worn on the PURL side. K1, P1 Ribbing for Sleeve Bands.

FRONT:

To the extreme RIGHT of machine, use OPEN CAST ON WITH WASTE YARN 36 (39) [42] sts. After knitting 9 to 11 rows, knit 1 row with Ravel Cord to the right side. Turn Counter to 0 and change to color 1. ON THE LEFT SIDE, increase 1 st. every 6th row 7x (8x) [9x] then increase 1 st. every 4th row 7x, 1 st. every 2nd row 3x then 2 sts. 2x, BUT AT THE SAME TIME, BEGIN THE INTARSIA DESIGN ON THE RIGHT after Row 48 (52) [56]. FOLLOW THE CHART for the INTARSIA DESIGN. After Row 80 (86) [92], ON THE LEFT, cast on 40 (42) [44] sts. (use separate yarn to cast on). Continue working the Intarsia Design as shown on the Chart. After Row 124 (132) [140], SHAPE NECK: Bind off 3 sts. 1x, 2 sts. 3x, 1 st. 4x. Continue in Design and after Row 150 (160) [170], mark the right side for the center of Front. After Row 162 (174) [184] on the right INCREASE 1 st. 4x, 2 sts. 3x, 3 sts. 1x. Work BACKWARDS, following the Chart from Row 124 (132) [140]. Front should be completed after Row 300 (320)[340].

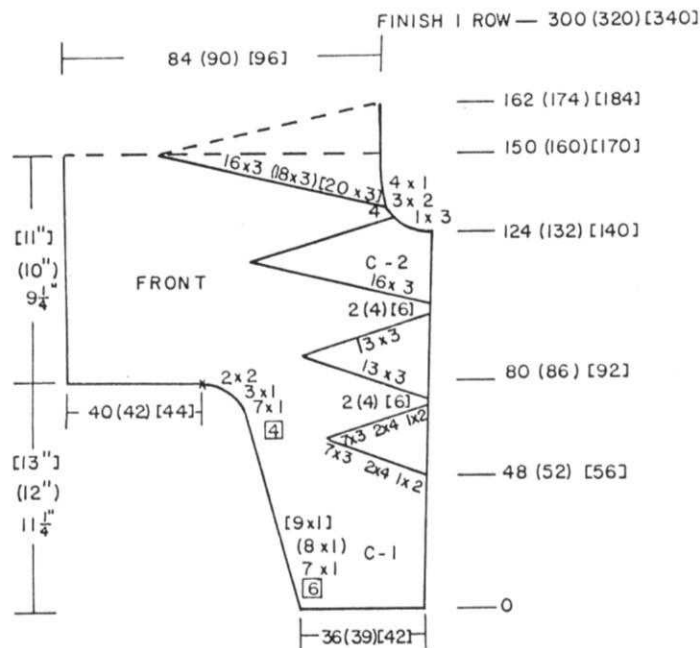

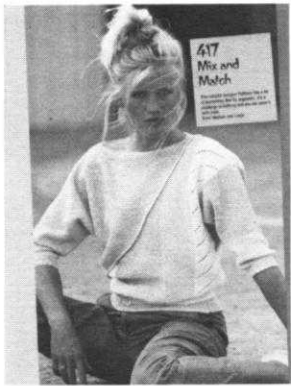

WOMAN'S PULLOVER

SIZES: Medium/Large
YARN: Viola

color 1 250
color 2 150
color 3 100
color 4 100

TENSION: 9 to 10 - Rib. 7/6 II
GAUGE: 12 sts. 18 rows = 2" (5 cm)

Knitted sideways on the machine with color stripes and an Eyelet Design. Punch Cards No. 1 and No. 2. Bands are K1, P1 Ribbing.

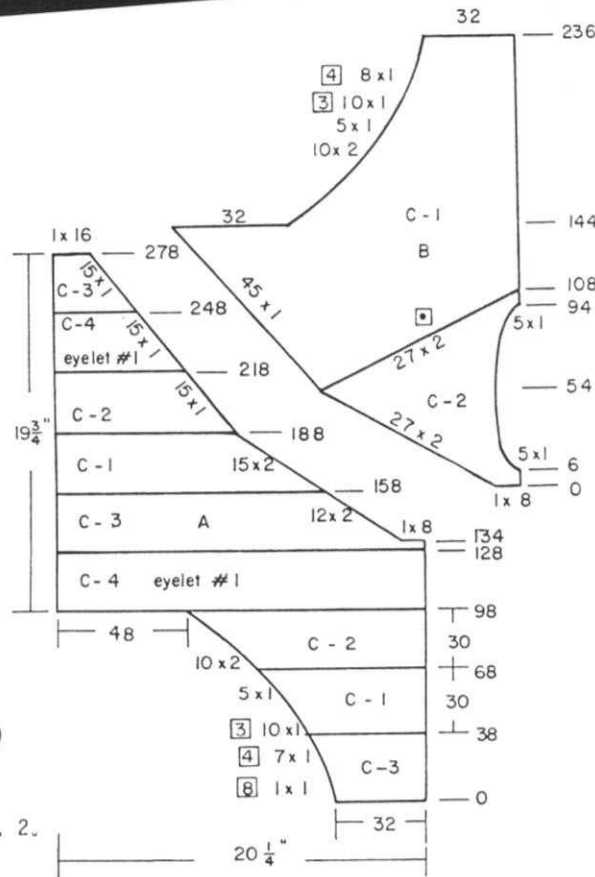

BACK: B

To the right of 0, cast on 8 sts. with color 2 and work Stockinette stitch.

ON THE LEFT, cast on 2 sts. 27x and after Row 6, DECREASE 1 st. 5x.

After Row 54, work SHORT ROWS.

ON OPPOSITE SIDE OF CARRIAGE, put into holding position 2 sts. 27x.

After Row 94, on the RIGHT, increase 1 st. 5x.

After Row 108, bring Carriage to the left side, turn Row Counter back to 54 and work INCREASE SHORT ROWS with color 1. ON OPPOSITE SIDE OF CARRIAGE, bring back into working position 2 sts. 27x. AND AT THE SAME TIME, on

on the LEFT, INCREASE 1 st. every 2nd row 45x.

After Row 144, on the LEFT, bind off 32 sts. then bind off 2 sts. 10x, 1 st. 5x, then 1 st. every 3rd row 10x and 1 st. every 4th row 8x.

After Row 236, remove the remaining 36 sts. onto contrast waste yarn.

FRONT:

Work the FRONT the same as the back WITH REVERSE SHAPING, casting on to the LEFT of 0 and reading right for left and left for right.

BACK: A

To the RIGHT OF 0, open cast on 32 sts. with contrast waste yarn. After knitting 9 to 11 rows, knit 1 row with Ravel Cord to the right side. Turn Counter to 0 and work Stockinette stitch with color 3.

ON THE LEFT SIDE, increase 1 st. every 8th row 1x, then 1 st. every 4th row 7x, 1 st. every 3rd row 10x. Continue to increase on the LEFT every 2nd row 5x, then 2 sts. 10x AND AT THE SAME TIME, change to color 1 after Row 38, to color 2 after Row 68.

After Row 98, cast on 48 sts. on the left, change to color 4 and WORK PUNCH CARD EYELET DESIGN No. 1.

After Row 128, change to color 3 and work Stockinette stitch.

After Row 134, bind off 8 sts. 1x on the right then DECREASE 2 sts. 12x on the right.

After Row 158, change to color 1, and decrease 2 sts. 15x on the right and change to color 2 after Row 188.

On the RIGHT, decrease 1 st. 15x.

After Row 218, change to color 4 and work EYELET PUNCH CARD No. 1 and decrease 1 st. 15x.

After Row 248, change to color 3 and Stockinette stitch and continue to decrease 1 st. 15x on the right. After Row 278, bind off the remaining 16 sts.

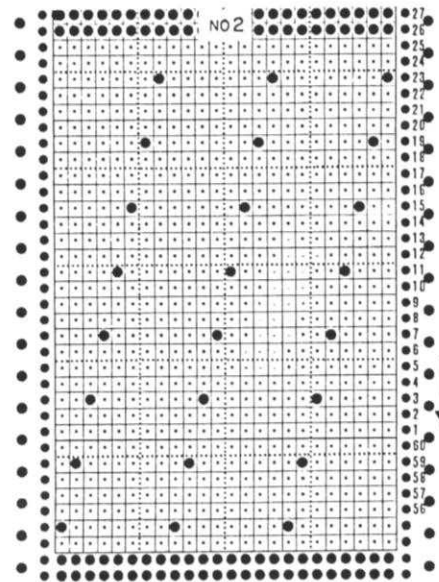
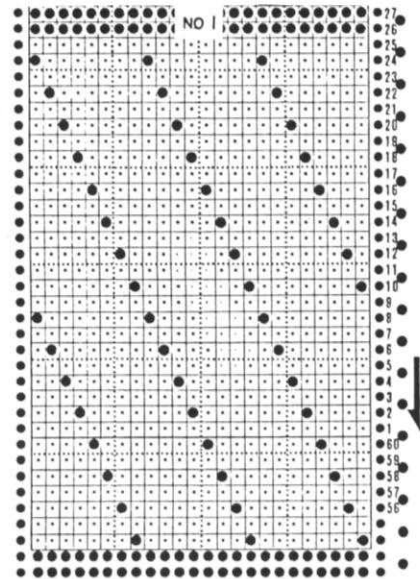
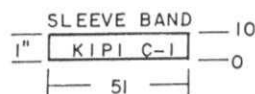
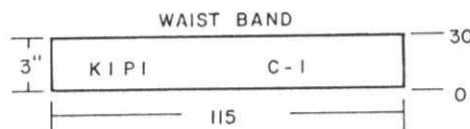

WAISTBAND: Make 2

Before making bands, single crochet A and B sections together from the RIGHT SIDE using color 3. (See Picture) With color 1, cast on 115 sts. and work 30 rows K1, P1 Ribbing. Transfer the ribber sts. to main machine, then pick up sts. from waist and hang onto these needles. Knit 1 very loose row then bind off the crochet method. REPEAT for other band.

SLEEVE BANDS: Make 1 color 1 and 1 color 3.

Close shoulders first. Cast on 51 sts. and work 10 rows K1, P1 Ribbing. Transfer the ribber sts. to main machine then hang open sts. of sleeve onto these needles as follows - 1-1-1-1-2 and REPEAT across. Knit 1 very loose row then bind off same as for waist band.

FINISHING: See General Instructions. With color 2, work 1 row single crochet then 1 row reverse single crochet around neckline.



WOMAN'S SUMMER TOP

SIZES: 6/8 (10/12) [14/16]

YARN: Viola

GRAMS:

color 1	150	200	200
color 2	50	50	50
color 3	50	50	50
color 4	50	50	50

TENSION: 8 or 9

GAUGE: 12 sts. 19 rows = 2" (5 cm)

Stockinette stitch, an Eyelet Design and Garter stitch (Use Garter Bar to reverse the knitting). Bands are K1, P1 Ribbing. Make 3 cords in different colors for the Spagetti Straps. KH 910 machine.

WAISTBAND: Make 2.

Cast on 103 (113) [123] sts. with color 1 and with Tension 6/6 II work 20 rows K1, P1 Ribbing. Transfer the ribber sts. to main machine. Pick up the sts. from waist and hang onto these needles. Knit 1 very LOOSE ROW then bind off the crochet method.

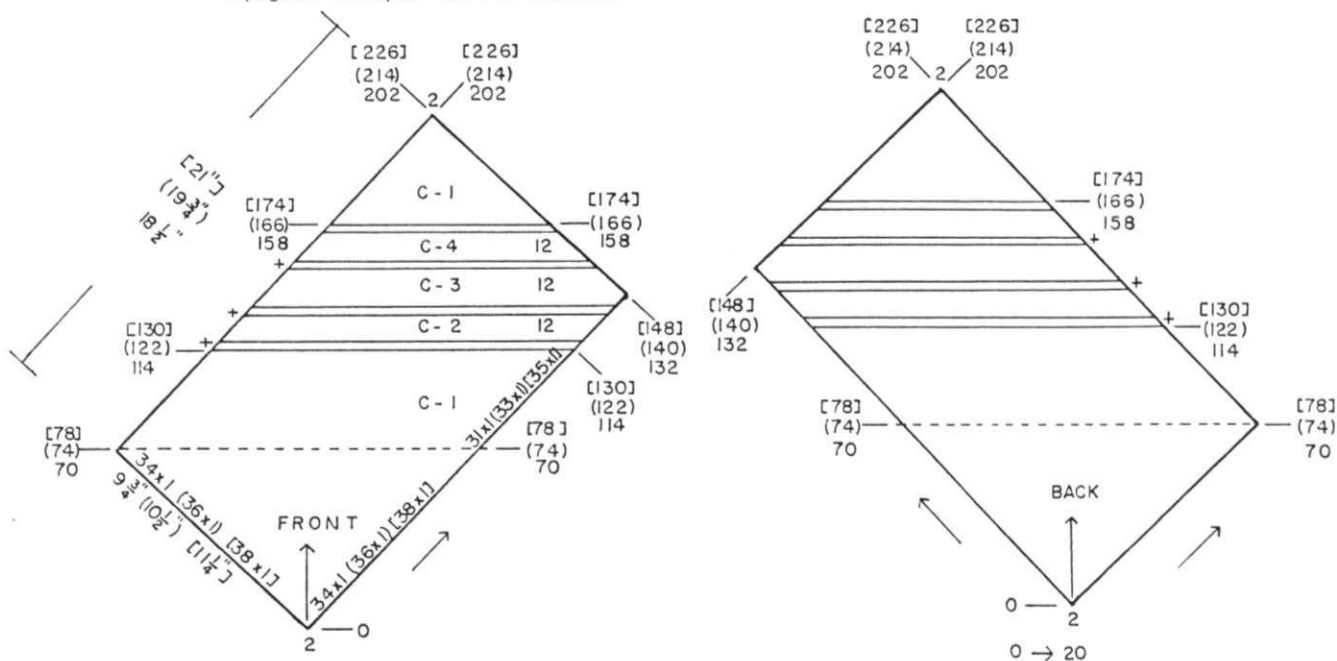

FRONT:

At needle 20 to the LEFT of 0, 'e' cast on 2 sts. with color 1. ON EACH SIDE, increase 1 st. every 2nd row 34x (36x) [38x]. After Row 70 (74) [78], ON THE LEFT SIDE, decrease 1 st. every other row 65x (69x) [73x] BUT AT THE SAME TIME, ON THE RIGHT continue to INCREASE 1 st. every 2nd row as shown on the Chart to Row 132 (140) [148] BUT AFTER ROW 114 (122) [130], REVERSE THE KNITTING and knit 2 rows, then REVERSE the knitting again. Set 910 Eyelet Design and Change to color 2. (See instructions along side Line Drawing for eyelet design). Knit 12 rows Lace Pattern. Reverse the knitting and knit 2 rows Stockinette stitch same as you did before. Reverse the knitting but BEFORE you reverse the sts., MARK needles ORANGE 6 and GREEN 8 and also mark the knitting with a strand of contrast yarn so as to make it easy for you to hang the sts. back onto the machine so that pattern will match.

Continue to follow the Line Drawing for color changes and reverse for the 2 rows of Stockinette stitch. AT THE SAME TIME, after Row 132 (140) [148], ON THE RIGHT SIDE ONLY, DECREASE 1 st. every 2nd row 34x (36x) [38x]. After Row 202 (214) [226], bind off the remaining 2 sts.

BACK:

FOLLOW THE CHART but cast on 2 sts. at needle 20 to the RIGHT of 0. and reverse the sides for the shapings.

STRAPS: Make 3 cords over 4 sts. using Tension 5 or 6. Use a different color for each strap. Set machine for making a cord and work approximately 20 inches long.

FINISHING:

Close side seams. Work 1 row single crochet around neck edge then 1 row REVERSE single crochet. Sew on straps.

- 2 rows color 1
- 12 rows color 2 - Pattern
- 2 rows color 2 - Stockinette
- 12 rows color 3 - Pattern
- 2 rows color 3 - Stockinette
- 12 rows color 4 - Pattern
- 2 rows color 4 - Stockinette

BE SURE TO REVERSE THE KNITTING BOTH BEFORE AND AFTER THE 2 ROWS STOCKINETTE STITCH.

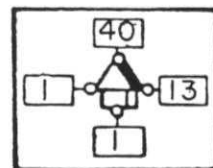
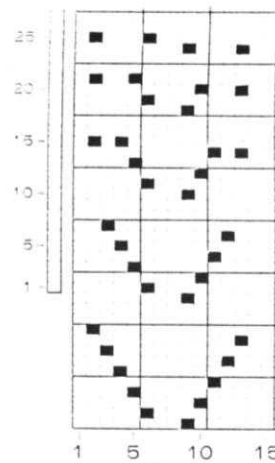

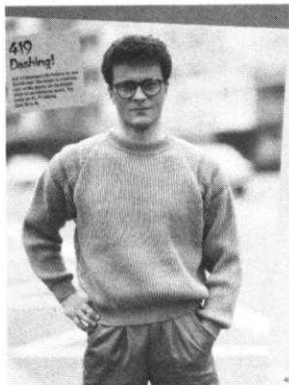

MAN'S FISHERMAN'S RIB PULLOVER

SIZES: 40/42 (44/46]

YARN: Regia

GRAMS:

color 1 700 750
color 2 50 50

TENSION: 5/5 II

GAUGE: 14 sts. 34 rows 2" (5 cm)

FISHERMAN'S RIB with color stripes in Stockinette stitch with color 2. Bands are K1, P1 Ribbing with Tension 4/4 II

BACK:

Cast on 151 (161) sts. with color 1 and work 26 rows K1, P1 Ribbing. Set machine for FISHERMAN'S RIB. Knit to Row 216 (230)
SHAPE RAGLAN:
ON EACH SIDE, decrease 1 st. every 3rd row 3x (6x) then ON EACH SIDE,*decrease 1 st. every 5th row, then every 4th row 21x in all REPEATING the decreases from *.
After Row 413 (436), bind off loosely.

FRONT:

Work the front the same as the back to Row 216 (230). ON EACH SIDE, decrease 1 st. every 3rd row 3x (6x) then ON EACH SIDE, decrease 1 st. every 5th, then every 4th row 20x in all, BUT AT THE SAME TIME, after Row 372 (395), bind off the center 23 (27) sts., transfer the left side ribber sts. to main machine and with a Ravel Cord, knit them back to A position to hold them while you complete the right side first.
*ON NECK SIDE, bind off 3 sts. 1x, 2 sts. 3x, 1 st. 12x. After Row 406 (428), bind off the last stitch. Bring the needles on the left into working position, by pulling on the Ravel Cord gently so that the sts. go into the latches of needles. Transfer the Proper sts to the Ribber. Knit 1 row to the left and turn Row Counter to 372 (395) and complete the left half. Follow the instructions from *.

SLEEVES: Make 1, reverse 1.

Cast on 71 sts. with color 1 and work 26 rows K1, P1 Ribbing. Change to FISHERMAN'S RIB and ON EACH SIDE, increase 1 st. every 16th (6th) row 1x, then every 12th row 10x (every 10th row 13x). After Row 158, ON EACH SIDE, increase 1 st. every 9th row 1x, then every 5th row 34x. The increases are completed after Row 340 BUT AT THE SAME TIME, after Row 338, transfer the ribber sts. to main machine and with color 2, work the 6 rows of Stockinette stitch, and BEGIN THE INCREASES ON EACH SIDE, after Row 340. Continue to FOLLOW THE CHART for the decreases ON EACH SIDE and FISHERMAN'S RIB with color 1 changing to 6 rows of stockinette stitch with color 2. After Row 436 (444) ON THE LEFT, (right for 2nd sleeve), bind off 4 sts. 2x.

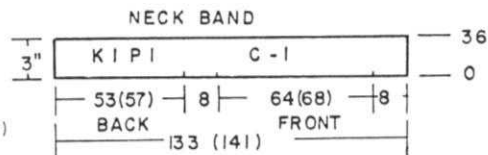
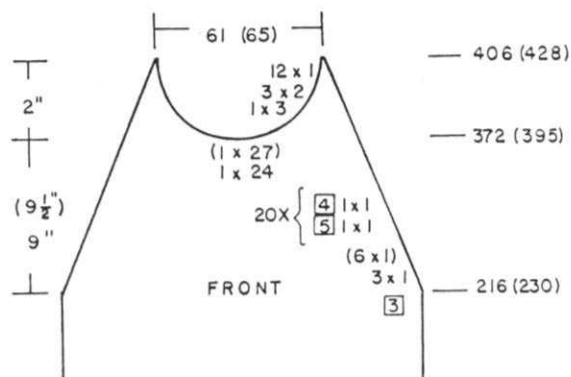
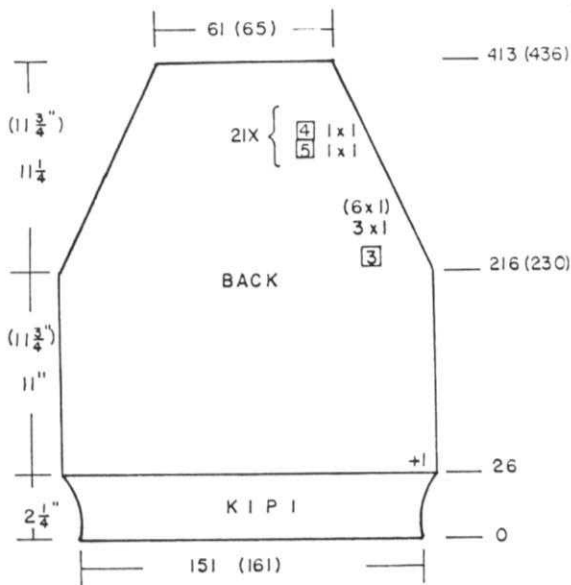
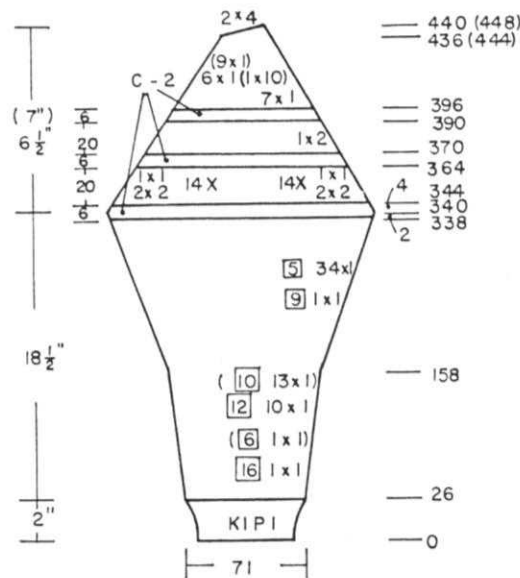

NECKBAND:

Set the sleeves in FIRST with exception of RIGHT BACK seam open so that you will be able to hang neckline back onto machine. Cast on 133 (141) sts. with color 1 and work 36 rows K1, P1 Ribbing. Transfer the ribber sts. to main machine. With wrong side facing you, pick up sts. around the neckline with 53 (57) sts. for back, 8 sts. for each sleeve, 64 (68) sts. for front. Knit 1 row Stockinette stitch, then remove the sts. onto contrast waste yarn. Close back seam then fold band in half to the inside and sew in place going through the open sts.

FINISHING: See General Instructions.



WOMAN'S CARDIGAN

SIZES: 6/8 (10/12) [14/16]
YARN: Multi-Show
GRAMS: 600 650 750
TENSION: 7 to 8 Rib, 3/3
GAUGE: 8 sts, 11 rows = 2" (5 cm)
 8 Buttons.

Made on the KH 230 Bulky machine and can be made on any Bulky machine.

A Cable Stitch Pattern.
 Bands are K1, P1 Ribbing.

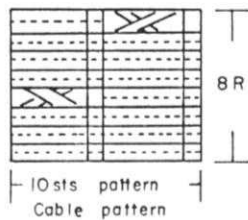

CABLE STITCH PATTERN:

Mark needle bed ON EACH SIDE of 0 beginning with needle 5 on each side, then every 10th on each side. Use DIFFERENT COLOR MARKINGS for every 5th stitch. This makes it easier for you to make the cables. SEE CABLE CHART. 4 sts. are used for cables - 2 and 2 are crossed as shown. The cables are alternated as shown with 4 rows between each cable.

MAKE POCKETS FIRST.

Cast on 21 sts. and work 22 rows Stockinette stitch. Remove the sts. onto contrast waste yarn. Make 2.

FRONT: Make 1, reverse 1.

Cast on 35 (39) [43] sts. and work 12 rows K1, P1 Ribbing. Transfer the ribber sts. to main machine and continue in Stockinette stitch with CABLE DESIGN.

Knit 4 rows, then begin the Cables throughout. See Chart and explanation.

After Row 34, leave 6 sts. on RIGHT (left for 2nd section) then remove the next 21 sts. onto contrast waste yarn.

Hang the open sts. of POCKET with wrong side facing you onto the empty needles then continue in Pattern.

After Row 94 (98) [102], SHAPE ARMHOLE: Bind off 3 (3) [4] sts. 1x, then 2 sts. 1x (2x) [2x] then 1 sts. 3x (2x) [2x].

After Row 121 (127) [133], SHAPE NECK: Bind off 3 (4) [5] sts. 1x, 3 sts. 1x, 1 sts. 4x (5x) [6x].

After Row 140 (146) [154], remove the sts. onto contrast waste yarn. Make left front with reverse shapings.

BACK:

Cast on 77 (83) [89] sts. and work 12 rows K1, P1 Ribbing. Transfer the ribber sts. to main machine.

Knit 4 rows Stockinette stitch then begin the CABLE DESIGN same as for front.

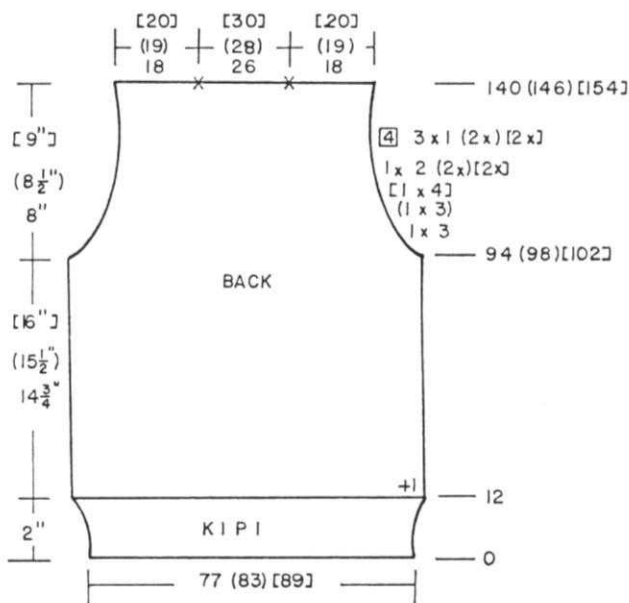

After Row 94 (98) [102] SHAPE ARMHOLE: ON EACH SIDE, bind off 3 (3) [4] sts. 1x, then 2 sts. 1x (2x) [2x], then every 4th row 1 sts. 3x (2x) [2x]. After Row 140 (146) [154] remove 18 (19) [20] sts. for EACH shoulder and 26 (28) [30] sts. for neck onto contrast waste yarn.

SLEEVES:

Cast on 41 (43) [45] sts. and work 12 rows K1, P1 Ribbing.

Transfer the ribber sts. to main machine and increase 1 st. on the right side.

Knit 4 rows, then begin the CABLE DESIGN as you did before.

ON EACH SIDE, increase 1 st. every 8th row 9x (10x) [11x].

After Row 94 (98) [102] SHAPE CAP:

ON EACH SIDE, bind off 4 sts. 1x, 3 sts. 1x, 2 sts. 2x, 1 sts. 5x (6x) [8x], 2 sts. 3x. After Row 118 (124) [132], bind off the remaining sts.

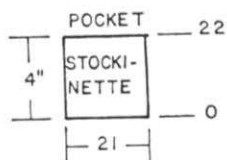
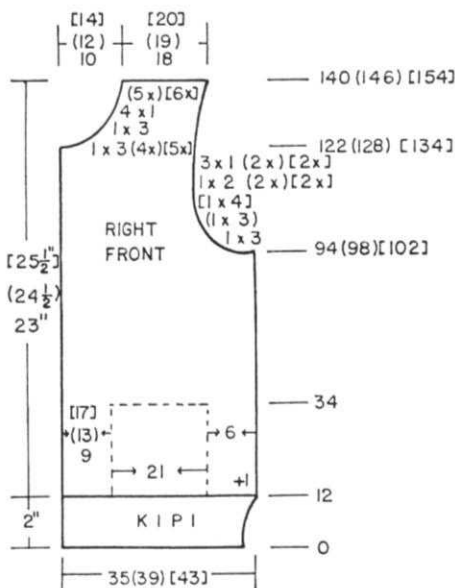
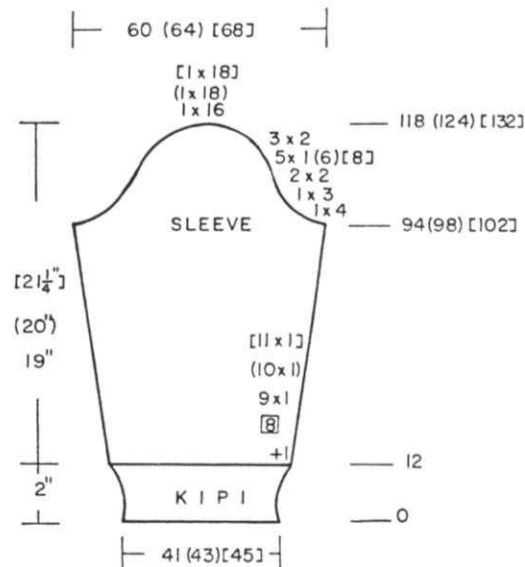

Continued

NECKBAND: (Knit BEFORE front bands)

Close shoulders first. Hang the back neck open sts. onto the machine and put the sts. behind the latches. (right side facing you)
Hang shoulder sts. with wrong side facing you onto these needles and leave sts. in the latches. Pull the front sts. through the back sts. Knit 1 VERY LOOSE ROW then bind off the crochet method.
Cast on 63 (67) [71] sts. and work 8 rows K1, P1 Ribbing. Transfer the ribber sts. to main machine, then pick up the sts. around neck. Knit 1 very loose row then bind off the crochet method.

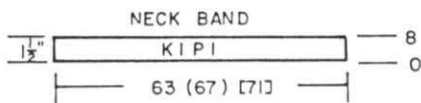

FRONT BANDS:

Make LEFT front band without button-holes.
Cast on 92 (99) [106] sts. and work 8 rows K1, P1 Ribbing. Transfer the ribber sts. to main machine and with wrong side facing you, pick up sts. down left front and hang onto these needles (See Picture). Knit 1 very loose row then bind off the crochet method.
FOR RIGHT FRONT BAND, work the same as left front EXCEPT after Row 4, MAKE BUTTONHOLES as follows. Leave 3 sts. on the left, then bring the NEXT and EVERY 11th (12th) [13th] needle to 'D' position. Transfer these selected sts. to neighboring needle and leave empty needles in working position. Knit 4 rows (to Row 8) then transfer the ribber sts. to main machine and finish same as for left band.

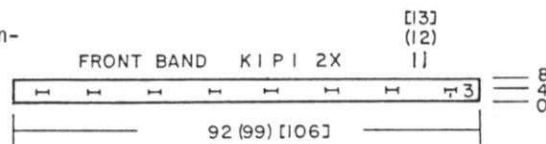

FINISHING: See General Instructions.



knitking SEMINAR & OPEN HOUSE 1984

It will run from October 8th through the 13th and will be held as usual on our premises at **1128 Crenshaw Blvd., Los Angeles, Calif. 90019.**

All experts at KNITKING will be in attendance plus many **acknowledged guest authorities**... We will repeat our very successful daily Fashion Show and Contest with daily prizes and the daily winners will be eligible for the finals and a **GRAND PRIZE** at the end of the Seminar. All types of garments and household items will be eligible. So, start preparing now. Knitting machine dealers and KNITKING employees will not be eligible for the contests.

You will be seeing the **NEW KNITKING KNITTING COMPUTER** and the **NEW ELECTRIC CARRIAGE KG 88.**

Admission to KNITKING Seminars is **FREE.** Coffee and doughnuts are available all day every day free of charge.

Regular Seminar visitors will tell you that ours are the best... So, enter the dates in your diary now... **October 8th through the 13th** and plan to be with us.

BRING NEEDLES FROM HOLDING POSITION E BACK TO B (KNITTING) POSITION - SUCH AS WHEN SHAPING A NECK ETC....

When you shape one side of a garment, you are holding needles on the opposite side in E or holding position. This is the usual procedure while you complete the neck shaping on the right side. When the right side is completed, you must bring the left side needles from holding to knitting position and the stitches must be put into the HOOKS of the needles. Here is a very easy way to do this without transferring each stitch into the latch with a transfer tool. When you have completed the right side, use a RAVEL CORD to knit 1 row over all the needles on the left. Be sure your carriage is set to knit all needles. The stitches will now be in the hooks of the needles. Gently pull out the Ravel Cord and the stitches will all be in the hooks of the needles. Be sure to turn the Row Counter back to the correct row and if your carriage is on the wrong side, bring it to the correct side by pushing in the Part Buttons before changing the Row Counter.

BIND OFF IN RIBBING

In most cases, when waistbands, neck or armbands are made in ribbing and are knitted separately, we transfer the ribbers stitches to the main machine, hang the garment edge onto the needles, knit 1 loose row and then bind off loosely. Always make sure that after you hang the garment onto the machine, that you bring ALL NEEDLES to E (holding) position, set your Carriage for knitting all needles and then knit 1 very loose row and bind off.

There is however a way to bind off in RIBBING if you want to hang the garment onto the machine first, then work the ribbing. Of course you will need to transfer every other stitch to the Ribber first (for K1, P1). Work the required amount of rows in ribbing. Do not transfer the sts. back to the main machine. Knit 1 row with a Ravel Cord and then about 6 or 8 rows with waste yarn. Remove the sts. from the machine by running the carriage across without yarn. To bind off the stitches, hold the knitting with right side facing and with a crochet hook and garment yarn, work a slip stitch crochet - go into the knit stitch facing you, from the front then go into purl stitch from the back. You control the tension so that you will have an even bind off that resembles a hand knit bind off. Remove the ravel cord and waste knitting will fall away. Try it.

YARN KITS FOR GARMENTS IN THIS ISSUE

Most of the garments in this issue of KNITKING MAGAZINE were knitted with yarns from our YARN CATALOGUE which illustrates the full range of colors available and includes actual yarn samples. If you do not have our Catalogue, please send \$3.00 and we will mail you one immediately and you will be able to choose your own colors.

VENETIA, our best selling yarn is not shown in the Catalogue. We have 20 colors available and if you tell us the color or colors you want, we will select a color as close as possible to your selection.

No. 400 - Yarn: Venetia
 SIZE: 44
 Price: \$16.02
 Shipping: 1.85

No: 401 - Yarn: Venetia
 SIZE: 12/14
 Price: \$16.02
 Shipping: 1.85

No. 402 - Yarn: Alanda	SIZES: 6/8 (10/12) [14/16]		
	Price: \$14.40 \$14.40 \$16.00		
	Shipping: 1.85 1.85 1.85		
No. 403 - Yarn: Multi-Show	SIZES: 6/8 (10/12) [14/16]		
	Price: \$26.55 \$29.50 \$32.45		
	Shipping: 1.85 1.85 1.85		
No. 404 - Yarn: Multi-Show	SIZES: 6/8 (10/12) [14/16]		
	Price: \$26.55 \$32.45 \$38.35		
	Shipping: 1.85 1.85 1.85		
No: 405 - Yarn: Vienna	SIZES: 36/38 (40/42)		
	PRICE: \$32.40 \$35.10		
	Shipping: 1.85 1.85		
NO. 406 - Yarn: Cordella	SIZES: 6/8 (10/12) [14/16]		
	Price: \$19.90 \$23.88 \$23.88		
	Shipping: 1.85 1.85 1.85		
No. 407 - Yarn: Amore	SIZES: 8/9 (10/11)		
	Price: \$21.51 \$23.90		
	Shipping: 1.85 1.85		
No. 408 - Yarn: Vienna	SIZES: 6/8 (10/12) [14/16]		
	Price: \$29.70 \$32.40 \$35.10		
	Shipping: 1.85 1.85 1.85		
No. 409 - Yarn: Cordella	SIZES: 6/8 (10/12) [14/16]		
	Price: \$ 9.95 \$11.94 \$13.93		
	Shipping: 1.85 1.85 1.85		
No. 410 - Yarn: Vienna	SIZES: 6/8 (10/12) [14/16]		
	Price: \$37.80 \$40.50 \$45.90		
	Shipping: 1.85 1.85 1.85		
No. 411 - Yarn: Vienna	SIZES: 6/8 (10/12) [14/16]		
	Price: \$37.80 \$40.50 \$45.90		
	Shipping: 1.85 1.85 1.85		
No. 412 - Yarn: Extra	SIZES: 36/38 (40/42)		
	Price: \$39.60 \$39.60		
	Shipping: 1.85 1.85		
No. 413 - Yarn: Alanda	SIZES: 6/8 (10/12) [14/16]		
	Price: \$17.60 \$17.60 \$19.20		
	Shipping: 1.85 1.85 1.85		
Leg Warmers -			
	Price: \$4.80 \$4.80 \$4.80		
	Shipping: 1.85 1.85 1.85		
No. 414 - Yarn: Regia	SIZES: 6/8 (10/12) [14/16]		
	Price: \$23.43 \$27.83 \$27.83		
	Shipping: 1.85 1.85 1.85		
No. 415 - Yarn: Multi-Show	SIZES: Small Medium/Large		
	Price: \$50.15 \$50.15		
	Shipping: 1.85 1.85		
No. 416 - Yarn: Show and Capriccio	SIZES: 6/8 (10/12) [14/16]		
	Price: \$27.75 \$27.75 \$30.20		
	Shipping: 1.85 1.85 1.85		
No. 417 - Yarn: Viola	SIZES: Medium/Large		
	Price: \$25.80		
	Shipping: 1.85		
No. 418 - Yarn: Viola	SIZES: 6/8 (10/12) [14/16]		
	Price: \$12.90 \$15.05 \$15.05		
	Shipping: 1.85 1.85 1.85		
No. 419 - Yarn: Regia	SIZES: 40/42 (44/46)		
	Price: \$33.00 \$35.20		
	Shipping: 1.85 1.85		
No. 420 - Yarn: Multi-Show	SIZES: 6/8 (10/12) [14/16]		
	Price: \$35.40 \$38.35 \$44.25		
	Shipping: 1.85 1.85 1.85		

knitking KNITTING COMPUTER

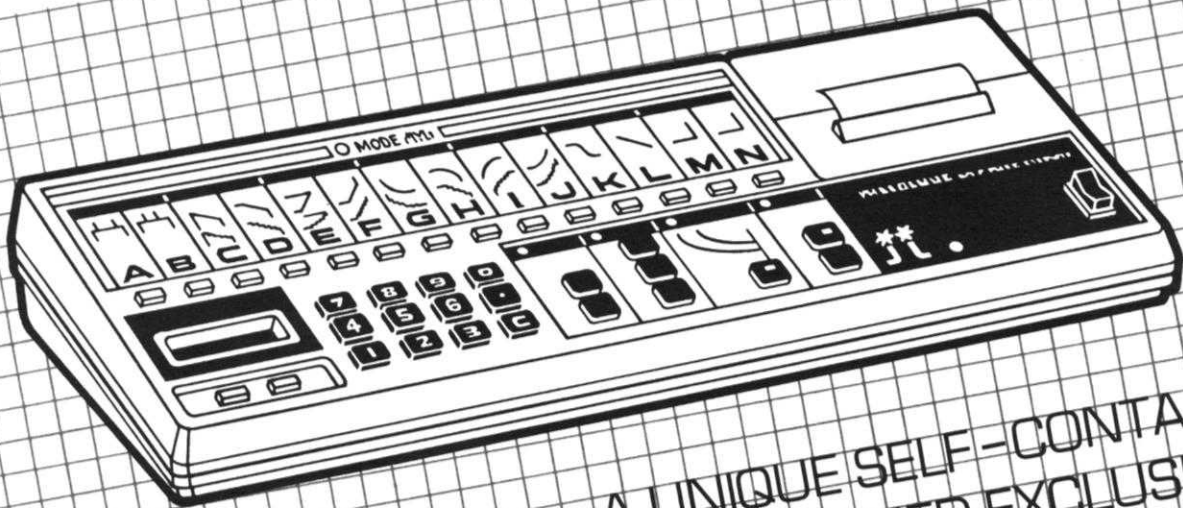

A UNIQUE SELF-CONTAINED
COMPUTER DESIGNED EXCLUSIVELY
FOR HAND AND MACHINE KNITTERS.

Every shape of garment sections, necklines, armholes, etc., is represented by a 'MODE' button. Push a Mode Button, program in your Stitch and Row Gauge, follow it with the Width and Length of the garment section, then watch the printer print out complete knitting instructions.

The Computing of knitting patterns can be done with standard computers plus expensive software, and you can easily spend thousands of dollars to obtain the same results as produced by the KNITKING Knitting Computer at a fraction of the price.

The KNITKING Knitting Computer operates with built in re-chargeable Nickel Cadmium Batteries... A charger is standard equipment as is a detailed Instruction Manual and some spare rolls of print out tape.

Price: \$499.00 (California residents add Sales Tax)
Order from your local dealer or direct from

**KNITKING — 1128 Crenshaw Blvd.,
Los Angeles, CA 90019**

420

Bulky Beauty

Want a warm Cardigan? then knit this one on your Bulky machine. The Cables are not difficult and well worth the extra time involved. Be sure to use our Multi-Show yarn. Bands are K1, P1 Ribbing. Sizes 6 to 16.



409 Ribbon Magic

Keep your eye on ribbon for a designer's touch. Thread it through a Lace pattern and embroider the circles in matching colors.
Sizes 6 to 16.



419 Dashing!

Knit a Fisherman's Rib Pullover for your favorite man. The stripes in a contrast color on the sleeves are Stockinette stitch for an interesting accent. The bands are K1, P1 Ribbing. Sizes 40 to 46.





408 Repeat Performance

The short Mini Dress or Long Pullover has its place in today's fashion. It's knitted in Fisherman's Rib. Bands are K1, P1 Ribbing.
Sizes 6 to 16.

412 Special.....

The KG 88 Electric Carriage was used for knitting the Man's special Pullover. A true Seed Stitch is combined with Stockinette Stitch...or you can make it on any Punch Card or Electronic machine using a simulated Seed Stitch. All bands are K1, P1 Ribbing. Sizes 38 to 42.



406
Two for One-
KG 88
Electric
Carriage

A sleeveless Shell has its own cover up. The Shell is Stockinette Stitch with color stripes and can be made on any knitting machine. The Jacket is Garter Stitch and was knitted on the KH 881 using the KG 88 Electric Carriage. Sizes 6 to 16.



KNITKING KH 891 WITH KG 89 ELECTRIC CARRIAGE

Feed in a pattern stitch card. Set the row counter to a specific number of rows, then push the start button and you can leave to watch T.V. or cook the dinner, read a book, etc., while your knitter knits merrily along. When it has knitted the preset number of rows, it will switch itself off. If it runs out of yarn, it will switch itself off. The KG 89 Electric Carriage will knit an unlimited variety of fancy Garter Stitch designs in addition to standard ribs.

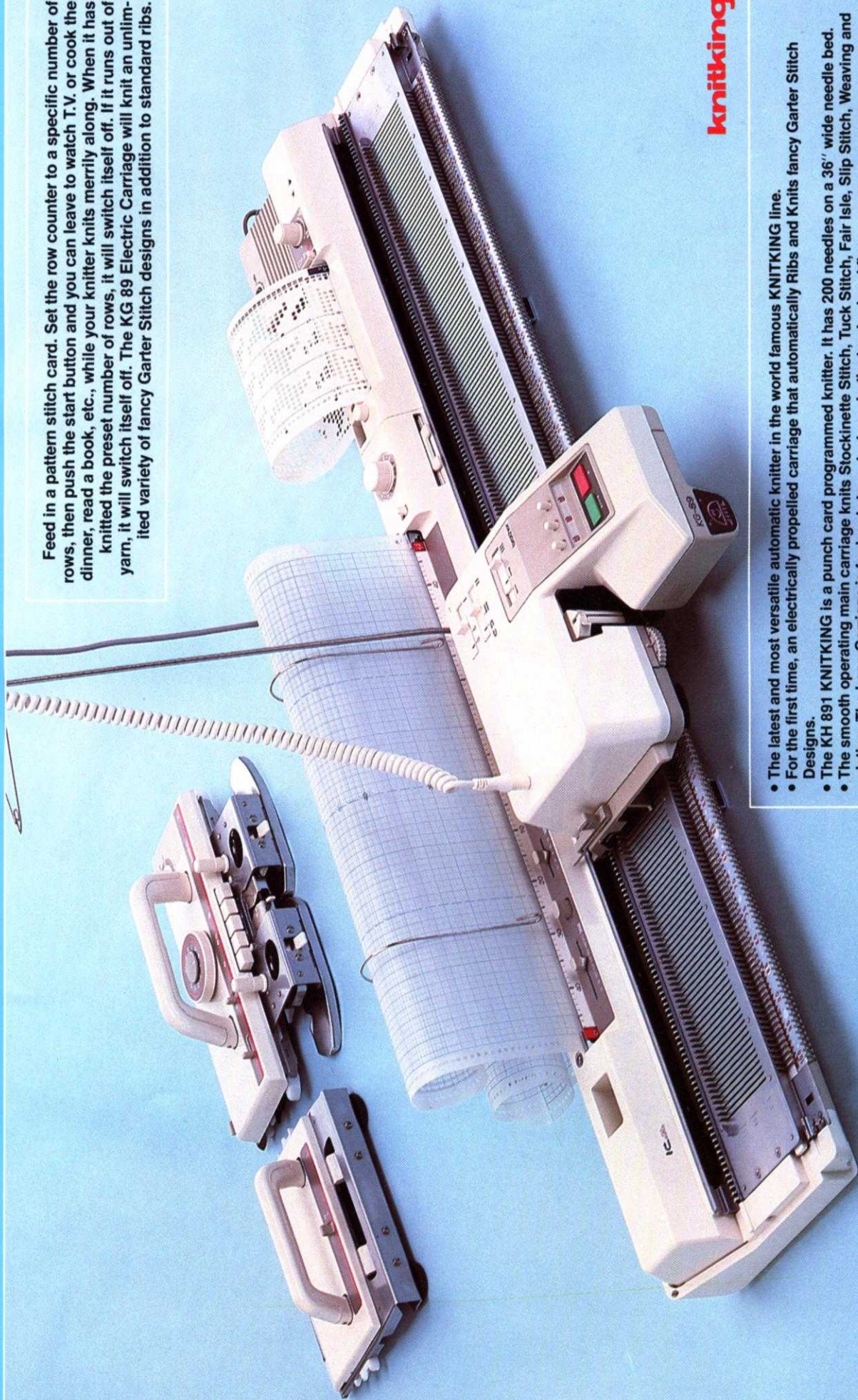

knitking

- The latest and most versatile automatic knitter in the world famous KNITKING line.
- For the first time, an electrically propelled carriage that automatically Knits and Knits fancy Garter Stitch Designs.
- The KH 891 KNITKING is a punch card programmed knitter. It has 200 needles on a 36" wide needle bed.
- The smooth operating main carriage knits Stockinette Stitch, Tuck Stitch, Fair Isle, Slip Stitch, Weaving and plating. The Lace Carriage is for lovely lace designs, both standard and fine.
- 20 Pre-Punched Pattern Cards for all types of pattern knitting are included with every machine. The built-in Knitleader Charting accessory tells you on a row by row basis when to increase and when to decrease. Simplifies the knitting of garments to accurate size.
- A complete kit of Tools, spare needles, cabling tools, lubricating oil and two, step by step Instruction Manuals with over 400 illustrations are included and there is a one year warranty on parts and service.

Order from your local dealer or direct from **KNITKING** — 1128 Crenshaw Blvd.
Los Angeles, CA 90019

Essentials.....

Order from your local Dealer or direct from
KNITKING—1128 Crenshaw Blvd.,
Los Angeles, California 90019

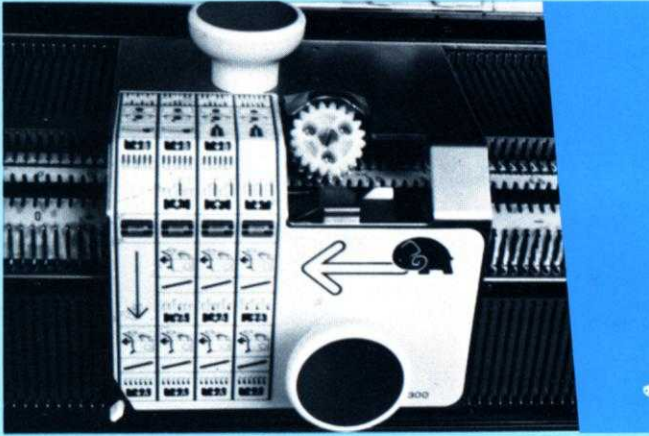

For fast and accurate transfer of stitches from Ribber to Knitter, the Automatic Transfer Carriage is ESSENTIAL.

Model 8300 is for Ribbers KR 900, KR 880, KR 850 and KR 830 and machine models KH 910, KH 891, KH 881, KH 860, KH 840 and KH 830.

The PM 10 Automatic Punch Card puncher is essential for speedy punching of all your punch card designs. It's O.K. for all KNITKING, Singer, Studio and Toyota punch card machines except the Singer/Studio F-370 machine which uses the PM 70 Automatic Puncher.

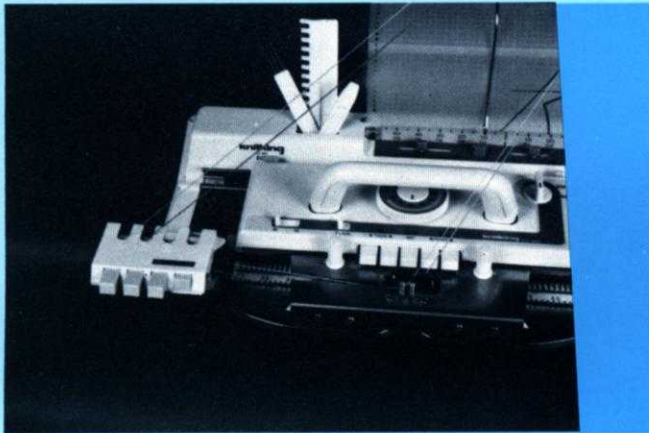
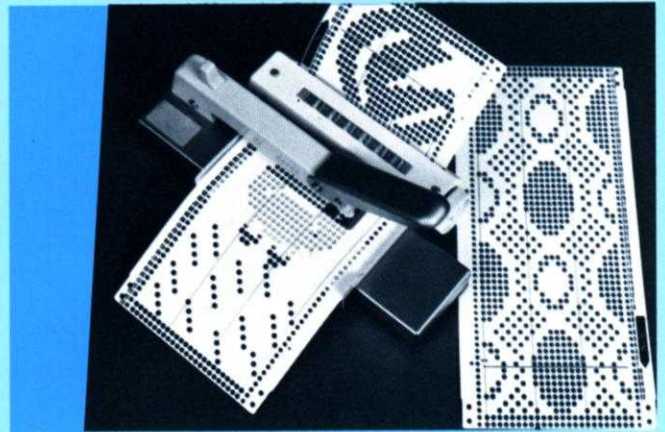

The KHC 820 Color Changer is essential for automatic changing of colors when knitting on KNITKING machines Models KH 820, KH 830, KH 840, KH 860, KH 881 and KH 910.

The KRC 830 Color Changer is essential for automatic color changing and the knitting of four color designs when using a Knitter and Ribber combination. It operates on Models KH 820, KH 830, KH 840, KH 860, KH 881 and KH 910 with Ribbing Attachment.

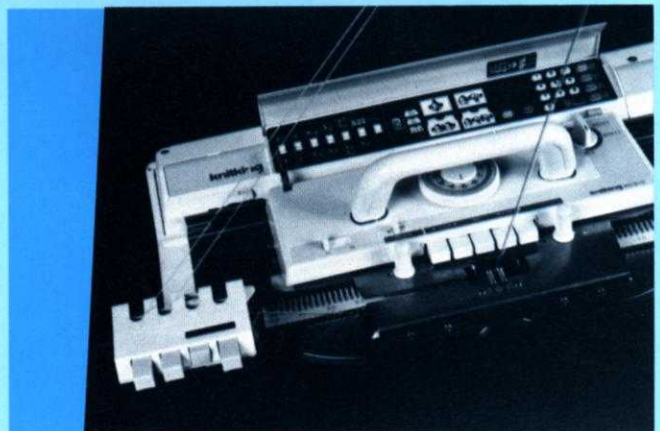

405

Casually Comfortable

A handsome Pullover in two colors. Fair Isle Border Designs are separated by Stockinette stitch for a standout pattern. Use Ribbing for the bands. A great beginner's pattern.
Sizes 36 to 42.

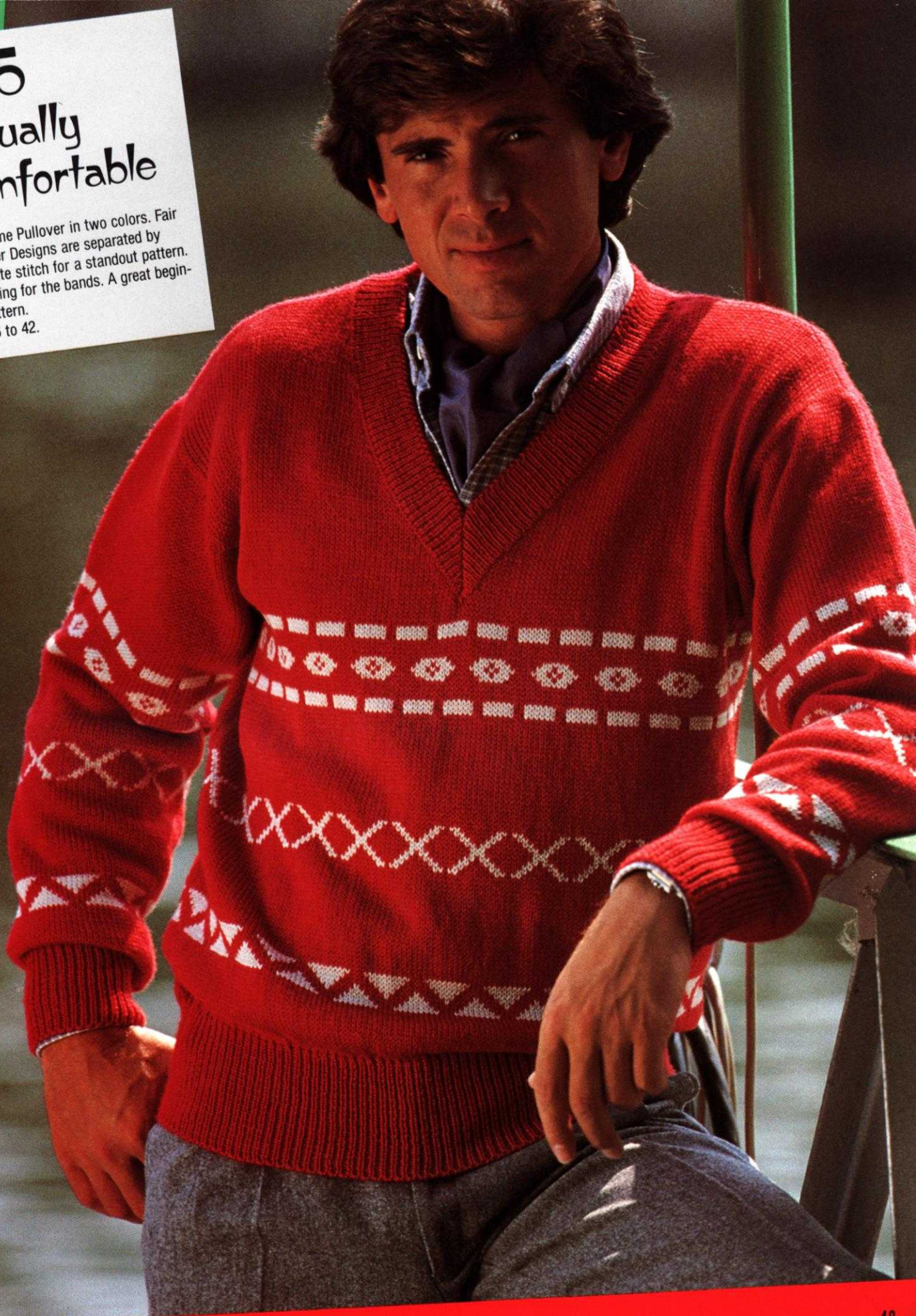

407 For School- For Play

Girls (Boys too) always welcome a colorful Pullover and you can put this one in your washing machine and dryer if you knit it with our Amore.
Sizes 8 to 11.



BULKY
KH 230
by
KNITKING

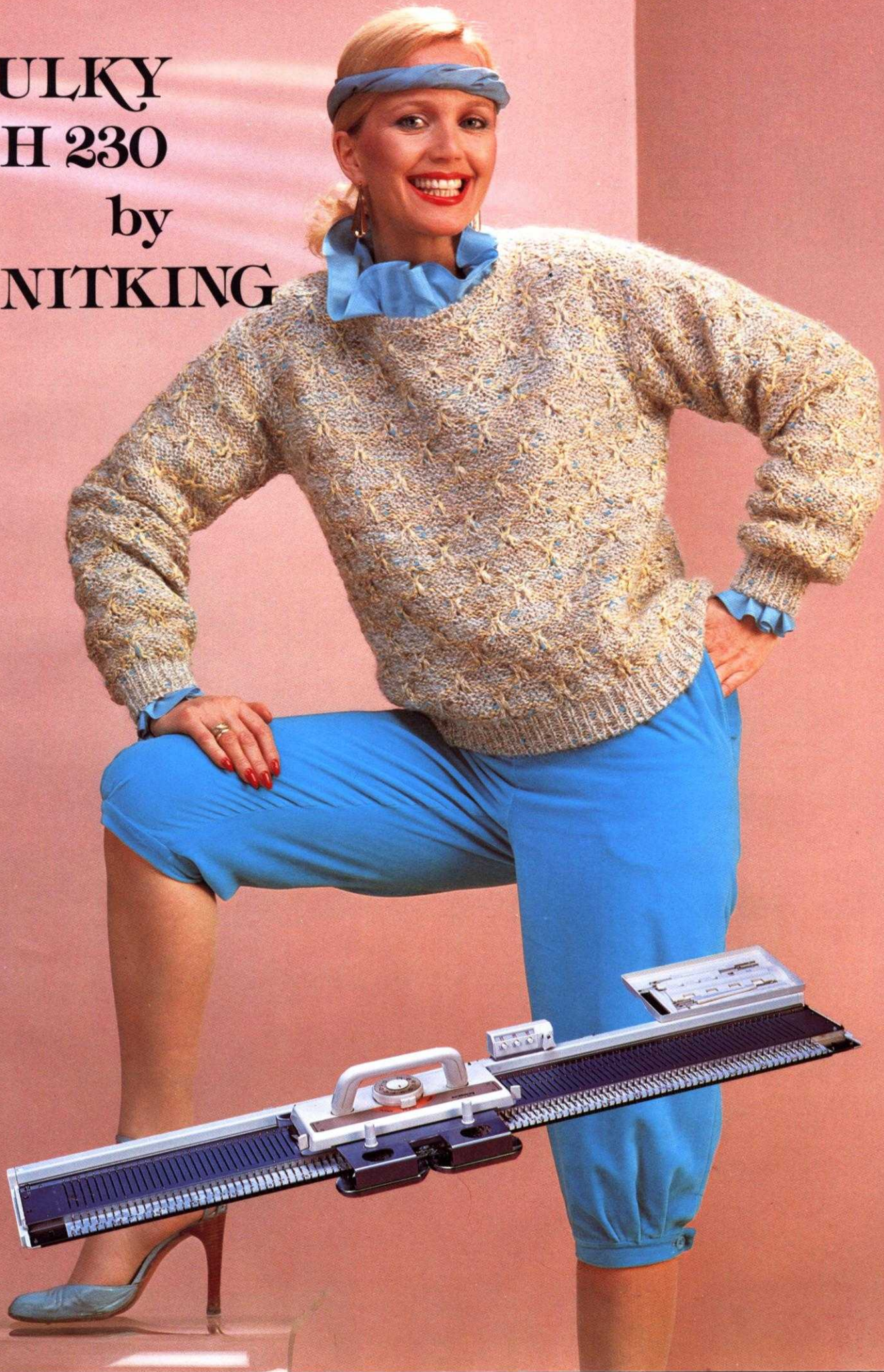

COMPUKNIT KH 910

'the world's finest knitting machine'

- Incredibly versatile... Anything you can trace or draw is automatically reproduced in your knitting in the colors and yarns of your choice.
- Simple to program and easy to operate, the COMPUKNIT KH 910 is the 'State of the Art' in home knitting machines. It is the only knitter made that has a memory unit to retain your program if you suffer a power outage or wish to move your knitter from one place to another.
- The maximum width of motif or pattern design possible on any punch card machine is 30 stitches (the standard is 24). The COMPUKNIT has no limit. It is possible to knit a single picture or lace design over the full width (200) needles of the needle bed. It will, in fact, do everything that's possible on a punch card machine and much much more.
- If you already own a knitting machine, you must consider trading up to a fantastic COMPUKNIT 910. If you have never owned a knitter before, start at the top and save money and save all the intermediate steps.



Order from your local Dealer or direct from
VISA and MASTERCARD accepted

KNITTING

1128 Crenshaw Blvd.
Los Angeles, CA 90019
Telephone: (213) 938-2077