

Neuma

Vol 19 # 2
knitking
magazine

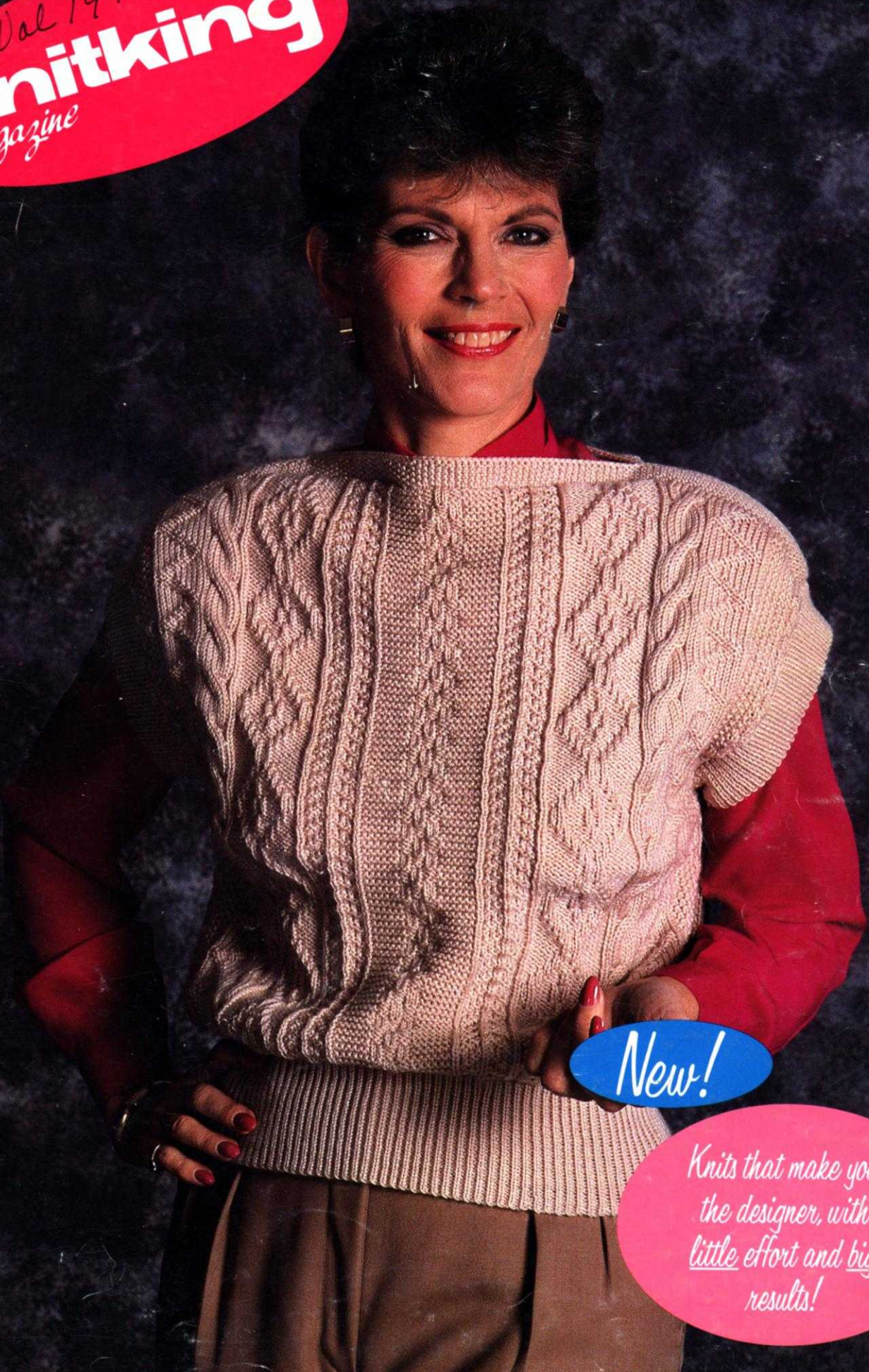

New!

*Knits that make you
the designer, with
little effort and big
results!*



434
Success

A Hounds Tooth Fair Isle Design for a dress that goes everywhere. It's smart and casually elegant. Use our lovely Venetia and knit it in sizes 6 to 16.

438 Perfection

One of the most popular designs of the day... A two piece dress has a soft flare at lower part of skirt. The Top is Short Row Knitting for the two color design on front section and the sleeves. Use Venetia Yarn. Sizes 6 to 16.



Table of Contents

PAGE NO.

421—Man's Pullover	13
422—Woman's Pullover	14
423—Woman's Top & Skirt	14
424—Woman's Pant Suit	17
425—Boy's Pullover	19
426—Woman's Pullover	21
427—Man's Pullover	22
428—Woman's Cover-Up & Pullover	23
429—Woman's Dolman Sleeve Pullover	25
430—Woman's Pullover	27
431—Woman's Two-Piece Suit	28
432—Woman's Two-Piece Suit	30
433—Girl's Lace Jacket	31
434—Woman's Hounds Tooth Dress	32
435—Girl's Dress	33
436—Woman's Pullover	34
437—Man's Cardigan	35
438—Woman's Top	37
439—Table or Buffet Runner	38
440—Baby Hang-Up	39

426 Aran Isle



KNITKING continues its tradition of beautiful knitted garments that are made with spectacular yarns and styled with the best of fashion in mind. You'll love our COVER MODEL. An Electric Carriage is needed to make this authentic Aran Isle sleeveless Pullover. It's knitted on the KH 910 for a widely spaced design plus cables. Use Alanda and knit it in sizes 6 to 16.

Publisher: KNITKING CORPORATION, 1128 Crenshaw Blvd., Los Angeles, Calif. 90019. Telephone: (213) 938-2079. Published quarterly. Subscriptions: USA—\$18.00 annually, single copies \$5.00; \$21.00 all other countries. The entire contents of KNITKING MAGAZINE are copyright and must not be reproduced in any shape or form without the express permission, in writing, of the publisher.
© COPYRIGHT 1985 by KNITKING CORPORATION.

Editorial

KNITKING had its biggest year ever in 1984...We sold more machines, yarns, books and accessories than even we predicted...In fact our sales volume in 1984 was more than double that of 1982...A 100% increase over 2 years is really something to brag about...We could not have achieved such remarkable growth however without the continued loyal support of our many thousands of customers and our almost 2,000 registered dealers. We thank you all for that support and we look forward with great confidence to an even bigger year in 1985.

GENIE is a division of KNITKING CORPORATION and for more than 20 years, GENIE has offered top quality machines at mail order prices. GENIE machines generally are not sold through dealers because of their relatively small profit margin, but their reputation for quality and value for money has increased over the years and more and more dealers are accepting them because customers are asking for them. The standard KH 710 GENIE has 200 needles, pushbutton Pattern Selection and a Lace Carriage all for a low price of \$289.50. Compare it yourself with any machines selling for under \$300.00 and you will easily see what excellent value it is.

We introduce in this issue of KNITKING MAGAZINE two new JUMBO GENIE Knitting Machines and one JUMBO Ribbing Attachment. The 120 needle JUMBO GENIE has a Carriage with Intarsia capability built in the needle bed, which is all steel. We are featuring it in our current subscriber sale for \$199.95 or complete with 120 needle Ribber for \$399.90. Compare it with the Bond knitter or any other machine in its price range and you will see what excellent value the JUMBO GENIE is. The widest Bulky made is the SUPER JUMBO GENIE 140 needle machine. Its needle bed is over 44" which means that your knitting width with a bulky yarn can be up to 44" wide enough for an Afghan without seams. This excellent machine is offered in our subscriber sale for a low \$279.95...a truly amazing value.

The most newsworthy product we introduced during 1984 was without a doubt the sensational Electric GARTER CARRIAGE (Models KG 88 and KG 89) and although our suppliers were not able to achieve their promised delivery date of October, we were able to thoroughly test the product and produce some outstanding garments for KNITKING MAGAZINE. The Cover garment of this issue is one of them and it emphasizes the ability of Electric Garter Carriages to knit stitches and designs hitherto impossible on home knitting machines....Watch out for more lovely knits made with these unique tools.

Many readers took the time to write praising the last issue of KNITKING MAGAZINE stating they thought it the best ever. We like it too but think this edition is even better. If you think you have seen the ladies modeling the garments before, you most likely have. They are top rated models featured in several T.V. commercials. Incidentally, they love our knits and we know that you will too.

436
Exciting!

A soft, warm and very easy to knit Pullover. The design is made by latching Angora through out of work needle spaces then accented with Tassels. Use your Bulky Machine and knit it with Multi-Show. Sizes Small, Medium, Large.



428

Perfect Duo





Two for one... A beautiful Pullover with separate Cover-Up. Both are knitted sideways on the machine with the Cover-up in a Tuck Stitch, the Pullover a combination of Tuck, Lace and Stockinette stitch. Venetia, Angora and Multi-Show are the yarns to use. Sizes Small, Medium and Large.

424
*Classy and
Classic*

Focus on our special Pant Suit. The pants are beautifully shaped for a smooth and flattering fit, the top has an Argyle border design knitted with easy 'Short Rows' or you can use the Intarsia method. Venetia Yarn.
Sizes 6 to 16.



423
*Tuck It—
Pleat It...*

Knit a swinging pleated Skirt and top it with a great Tuck Stitch Pullover. It is made with our popular Venetia yarn in sizes 6 to 16.



431
Dramatic

Weave your way to an elegant Suit. The Jacket is knitted over every other needle in a Weaving pattern that is worn on the purl side. The Skirt is pleated. Use Venetia with Multi-Show for weaving. Sizes 6 to 16.



432
Contemporary

Perfect for travel or special occasions.
The Skirt is the same as for 431 and
the Weaving Design is the same but
this time the knit side is the right
side. Venetia with Wool Tweed for
weaving. Sizes 10 to 16.





430
Short Row
Fun

Arty and unique is this artistic Design knitted on a BULKY machine. It's quick to knit and gorgeous to look at. Sizes small, medium and large. Use Venetia, Multi-Show and Angora.

General Instructions

THE PRINTED INSTRUCTIONS

Follow the printed instructions or use them in combination with the Charts. Where there is any question in the instructions, you have the Charts to show you how the section will look.

Be sure to READ AHEAD so that you KNOW what to do for the size you are knitting. In the shapings, where the number of stitches are the same but the number of times different, you might find shapings like this...3 sts. 1 x (2x) (3x)—so that for the first size you will bind off 3 sts. 1x, 2nd size 3 sts. 2x, 3rd size 3 sts. 3x. Sometimes the ROWS will be different for each size—so you must watch out for different row numbers.

Shoulder and neck shapings for the back section of a garment usually are shaped at the same time—so ALWAYS WATCH for the words AT THE SAME TIME.

HOLDING STITCHES ON THE LEFT SIDE WHILE SHAPING THE RIGHT SIDE

There are different ways to hold stitches on one side while completing the other side. Usually, we tell you to bind off the center sts. for neck and put the left side into holding position while completing the right side. The easiest way and really the best way for beginners is to take a piece of RAVEL CORD and hand knit the center neck stitches, pulling them back against the needle bed of machine to the "A" or out of work position. The stitches remain in the HOOKS of the needles so you are really only knitting them HALF WAY. With another color of Ravel Cord, knit the remaining sts. on the left side in the SAME WAY.

It is important to protect these held stitches in some way—so you can either hang a REVERSING BAR so that the EYES of the Bar go BETWEEN the Gate Pegs on the machine and that the UPPER TIPS of Bar only—show above the needle bed...OR the simplest way is to use a piece of 1 inch masking tape and GENTLY place it beneath the knitting—right below the gate pegs. Do NOT press the tape—only enough pressure to hold it in place. This will prevent the Carriage (or Slide) from marking the held section.

It is VERY IMPORTANT that you mark the PATTERN ROW where you divide for the split for NECK (or SHOULDER) shaping....If you are using a PUNCH CARD—MARK THE CARD—if you are using an ELECTRONIC machine, MARK THE DESIGN WINDOW. Also take note of the Row number for the division. When you are ready to work the left section, bring the HELD stitches back to B (working) position by pulling each end of the Ravel Cord GENTLY and rip it off—be sure to align all needles straight in the B or knitting position.

Now you are ready to REFER TO YOUR OWN INSTRUCTION MANUAL for your machine—to set the controls to begin knitting the left half. The neck stitches can be bound off after completing the right side or you can leave them in hold until each side is finished, then bind them off or remove them onto contrast waste yarn ready to be picked up for knitting a neckband or for other finishing.

FULL FASHION DECREASING OR INCREASING

For Stockinette stitch, use the Full Fashion method for decreasing or increasing (except for regular cap shaping on sleeves where you decrease the edge stitch).

TO DECREASE: Hang the 3rd stitch onto the 2nd stitch then move the end stitches in to fill the empty needle.

TO INCREASE: Move the 2nd end stitches 1 needle outward, then pick up the 3rd stitch from the row below and hang it onto empty needle.

PATTERN SYMBOLS

() Symbol for 2nd size.

[] Symbol for 3rd size.

There are up to 3 sizes given for Patterns in KNITTING MAGAZINE. For example, the Charts and printed instructions will show the cast-on as...124—First size. (132)—Second size. [140]—Third size.

R = ROW

◻ Needles in holding position.

⊗ Needles back into working position.

< For Short Row Knitting

THE SAMPLE SWATCH

Before you knit any garment, you must knit a sample swatch using the yarn you have chosen for your garment. If you do not get the correct Stitch and Row Gauge as given for a Pattern in KNITTING MAGAZINE—try different tensions. If you are using the specified yarn, you should be able to get the correct gauge using one of the tensions shown. If you are using other yarns, you may have to make several swatches—but the gauge is very important.

To make a sample swatch—Cast on 60 stitches with waste yarn and knit 6 rows. Mark the tension number for your sample swatch by making holes (you can do this with a Lace Carriage or by hand), 4 transfers for Tension 4, 6 transfers for Tension 6, etc. Knit 6 more rows.

Change to garment yarn and set Counter at 0. Knit 30 rows (in Stockinette stitch or Pattern stitch—according to the garment). With contrast waste yarn knit the 10th stitch FROM EACH SIDE—by hand. Knit 30 rows. Change to waste yarn and knit 12 rows. Remove the sts. from the machine by pushing the Carriage (or Slide) across without yarn.

Pull and stretch the sample swatch both lengthwise and diagonally from corner to corner, then lengthwise again. Gently block the swatch (KNITTING PRESSING CLOTHS are great for this)—or you can allow the sample to rest several hours or even over night so that the stitches can return to their basic form. USE KNITTING CONVERTA TAPE for MEASURING YOUR SAMPLE (or the KNITTING INSTANT STITCH AND ROW GAUGE MEASURE).

If you use the Converta Tape, pull out the Tape to measure BETWEEN the 40 marked stitches in the center of your swatch. Move the red marker on the Tape so that it points to 40 stitches on the TAPE. Your stitch gauge to 2" (5 cm) will show in the RED WINDOW. To find the number of rows in 2" (5 cm), place the Tape to measure over the 60 rows, push the red marker to 60 on the Tape and your row gauge for 2" (5 cm) will show in the red window.

If you do not own a KNITTING CONVERTA TAPE or a Stitch and Row Measure, you must count the number of stitches and rows to 2" (5 cm) after marking a 2-inch square in the center of your knitting.

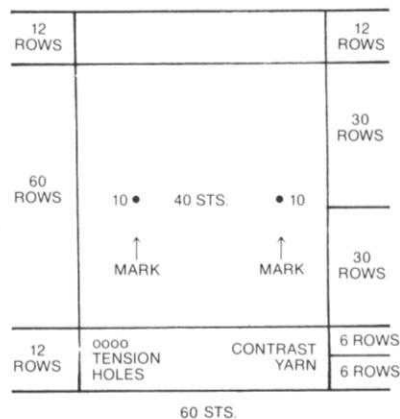

FINISHING

Gently block all sections—For PULLOVERS, JACKETS and DRESSES: Join the front to back at shoulders and sides. Sew sleeves together and set in. Hem lower edge and sleeve edges if needed. For a double neckband or armhole, band sew 1 edge to inside and 1 to the outside of neck or armhole. For a single ribbed band, sew 1 edge to the outside of neck or armhole edge. For a cardigan or jacket with buttonholes, finish buttonholes and sew on buttons.

PANTS: Join front to back at sides. Sew inside leg seams, then join to center front and back. Make hem at waistline and insert elastic. Hem lower edge of pants' legs.

◻ Needle not used—in out of work position.

3x1

4

The number in the box is the number of Rows between shapings. The 3 x 1 above the box gives you the sts. and number of times to make the decreases (or increases)—FOR EXAMPLE: 3 x 1 over the box with 4 means—At the given Row number, *decrease 1 st. knit 4 rows* and REPEAT from * to * 2 times more for a total of 3 times in all. All decreasing (or increasing) WITHOUT ROW NUMBER IN BOX must be made on EVERY 2nd ROW.

421



SLEEVES:

Cast on 80 (90) sts. and work 18 rows K1, P1 Ribbing. Transfer the ribber sts. to main machine and continue in PATTERN with Tension 8. ON EACH SIDE, increase 1 st. every 10th row 7x. After Row 74 (78) ON EACH SIDE leave 6 sts. in Stockinette stitch and continue in Pattern as you did for back and front. After Row 90 (98), STOP PATTERN. Work Stockinette stitch to Row 100 (108) then bind off LOOSELY.

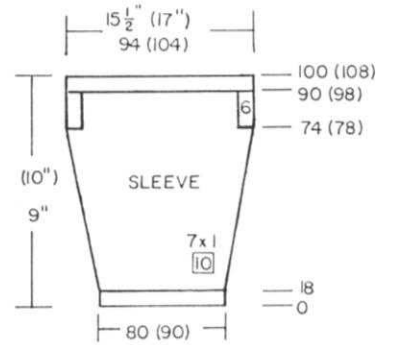

MAN'S PULLOVER

SIZES: 40/42 (44/46)
 YARN: Amore
 AMOUNT: 6 7 balls
 TENSION: 8 Rib. 2.1/2.1 II
 GAUGE: 12 sts. 20 rows = 2" (5 cm)

A Zig-Zag Eyelet Design. Punch Card. Bands are K1, P1 Ribbing.

BACK & FRONT - the same.

Cast on 123 (135) sts. and work 18 rows K1, P1 Ribbing. Transfer the ribber sts. to main machine and continue in Eyelet Design with Tension 8. Knit to Row 160 (170). Continue in Eyelet Design BUT AT THE SAME TIME, ON EACH SIDE, keep the 21 (23) sts. in Stockinette stitch. After Row 168 (178), bind off 15 (17) sts. Keeping 6 sts. ON EACH SIDE in Stockinette stitch, continue in Pattern to Row 232 (248). STOP PATTERN. Change Tension to 6 and work 10 rows Stockinette stitch. After Row 242 (258), ON EACH SIDE, bind off k4 (16) sts. Change Tension to 5 and ON EACH SIDE, increase 1 st. EVERY ROW 9x to Row 252 (268). Knit 1 row Tension 8 then remove the sts. onto contrast waste yarn. Make second section the same.

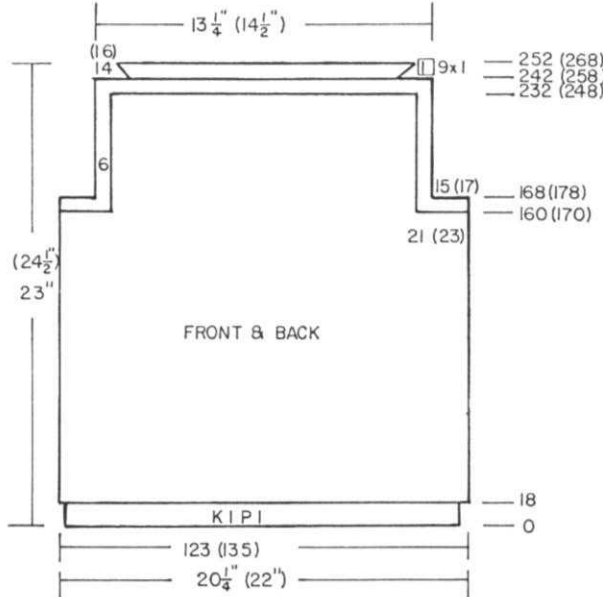

ALWAYS knit 2 rows Stockinette stitch before beginning Lace Pattern.

PATTERN:

*LACE CARRIAGE 2 times.
 Knit 2 rows.
 REPEAT FROM * 4 times more.
 ** LACE CARRIAGE 4 times.
 Knit 2 rows.
 REPEAT FROM ** 4 times more.
 REPEAT FROM BEGINNING throughout.

FINISHING: See General Instructions. Fold neckband to the inside and sew down in place through the open sts. Remove waste yarn.

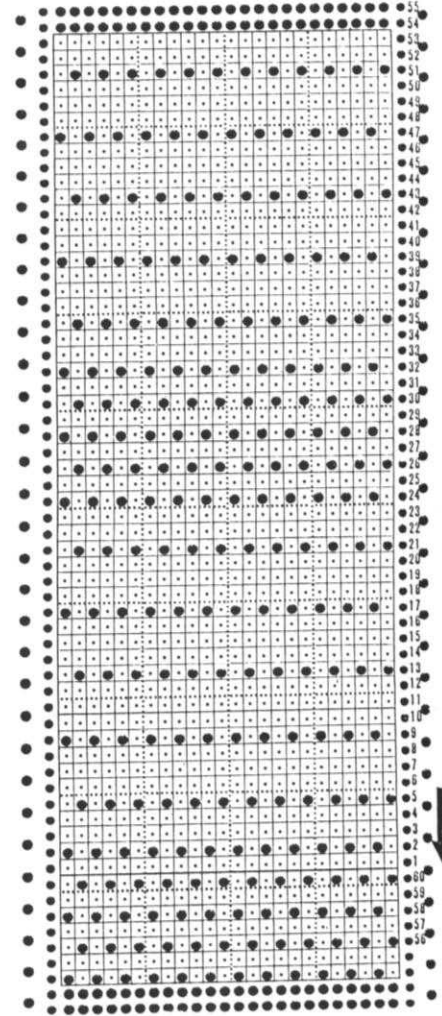

knitking SEMINAR & OPEN HOUSE 1985

It will run from Sept. 16th through the 21st and will be held as usual on our premises at 1128 Crenshaw Blvd., Los Angeles, Calif. 90019.

422



WOMAN'S PULLOVER

SIZES: Medium (Large)
 YARN: Amore
 AMOUNT: 5 6 balls
 TENSION: 8 - Rib. 2/2 II
 GAUGE: 12 sts. 20 rows = 2" (5 cm)

A Zig-Zag Eyelet Design. USE SAME PUNCH CARD AS Man's Pullover No. 421. Bands are K1, P1 Ribbing.

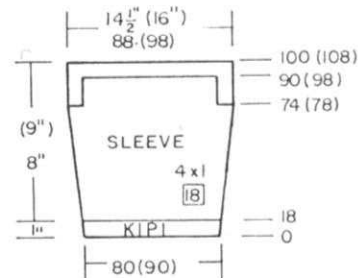

BACK & FRONT - the same.

Cast on 123 (135) sts. and work 18 rows K1, P1 Ribbing. Transfer the Ribber sts. to main machine and continue in Eyelet Design with Tension 8. Knit to Row 136 (144) Continue in the Eyelet Design but AT THE SAME TIME, ON EACH SIDE, keep the 21 (23) sts. in Stockinette stitch. After Row 144 (152), ON EACH SIDE, bind off 15 (17) sts. Keeping 6 sts. ON EACH SIDE in Stockinette stitch, continue in Pattern to Row 204 (218). STOP PATTERN. Change tension to 6 and work 10 rows Stockinette stitch. After Row 214 (228) ON EACH SIDE, bind off 14 (16) sts. Change Tension to 5 and ON EACH SIDE, increase 1 st. EVERY ROW 9x to Row 224 (238). Knit 1 row Tension 8 then remove the sts. onto contrast waste yarn. Make second section the same.

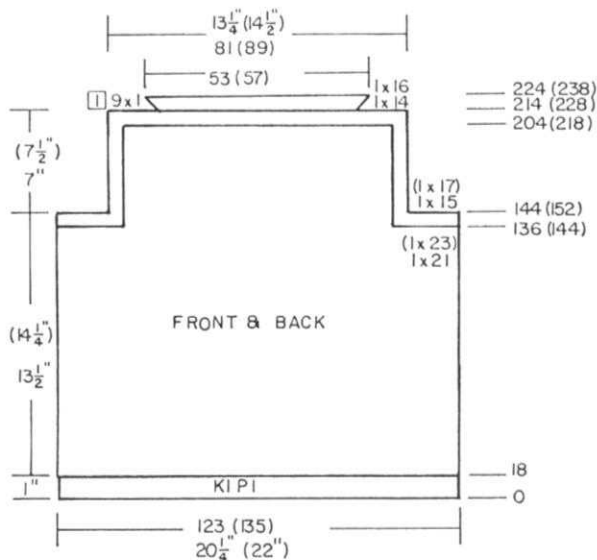

SLEEVES:

Cast on 80 (90) sts. and work 18 rows K1, P1 Ribbing. Transfer the ribber sts. to main machine and continue in Pattern with Tension 8. ON EACH SIDE, increase 1 st. every 18th row 4x. After Row 74 (78) ON EACH SIDE, leave 6 stitches in Stockinette stitch and continue in Pattern as you did for the back and front. After Row 90 (98), STOP PATTERN. Work Stockinette stitch to Row 100 (108). Bind off LOOSELY.

FINISHING:

See General Instructions. Fold neckband to the inside and sew down in place through the open sts. then remove waste yarn.

423



WOMAN'S TOP & SKIRT

SIZES: 6/8 (10/12) [14/16]
 YARN: Venetia
 AMOUNT: 2 1/2 lbs. for all sizes.
 TENSION: 5 to 6 Rib. 1/1 II
 GAUGE: 14 sts. 34 rows = 2" (5 cm)

A Tuck Stitch Pattern for the top. Punch Card. Bands are K1, P1 Ribbing. Shoulder bands and shoulder pads and neckbands are Stockinette stitch using Tension 3.

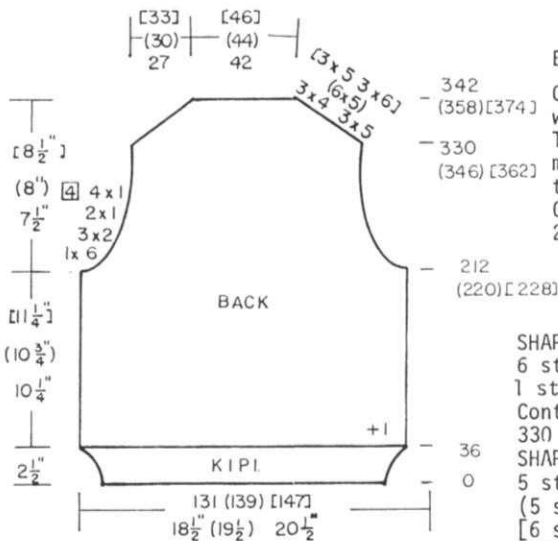

BACK:

Cast on 131 (139) [147] sts. and work 36 rows K1, P1 Ribbing. Transfer the ribber sts. to main machine and increase 1 st. on the right side. Continue in Tuck Pattern to Row 212 (220) [228].

SHAPE ARMHOLE: ON EACH SIDE bind off 6 sts. 1x, 2 sts. 3x, 1 st. 2x, 1 st. every 4th row 4x. Continue in Pattern to Row 330 (346) [362].
 SHAPE SHOULDER: ON EACH SIDE bind off 5 sts. 3x, 4 sts. 3x (5 sts. 6x) [6 sts. 3x, 5 sts. 3x]. After Row 342 (358) [374], bind off the remaining sts.

FOR SKIRT, use Skirt Pattern No. 431 in this issue of KNITTING MAGAZINE.

Continued

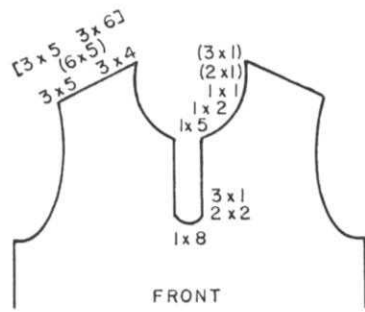

- 342 (358) [374]
- 330 (346) [362]
- 294 (306) [318]
- 222 (230) [238]
- 212 (220) [228]

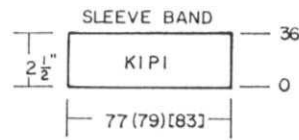

SLEEVE BANDS:

Cast on 77 (79) [83] sts. and work 36 rows K1, P1 Ribbing. Transfer the ribber sts. to main machine then hang the open sts. of sleeve onto these needles, doubling every 3rd stitch. Knit 1 loose row then bind off the crochet method.

ARMHOLE BAND

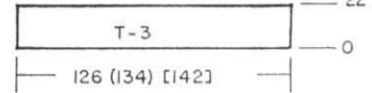

SEW UP SHOULDER SEAMS BEFORE MAKING THE FOLLOWING BANDS.
ARMHOLE BAND:

Cast on 126 (134) [142] sts. and work 22 rows Stockinette stitch with Tension 3. Hang the hem, then with knit (wrong) side facing you, hang the edge of armhole onto these needles and bind off LOOSELY. Repeat for other armhole.

LEFT SIDE NECKBAND:

Cast on 30 (32) [34] sts. and work 22 rows Stockinette stitch with Tension 3. Hang hem then with knit (wrong side facing you, hang the neck edge from shoulder to front neck onto these needles then bind off LOOSELY.

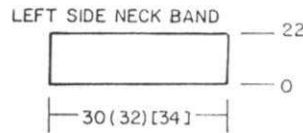

RIGHT SIDE & BACK NECK BAND:

Cast on 68 (72) [76] sts. and work same as for left side neckband. Hang hem then hang the back neck and right neck edge onto these needles. Bind off LOOSELY.

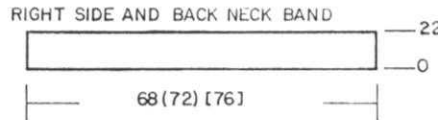

FRONT OPENING BAND:

Cast on 76 (78) [80] sts. and work same as other bands.

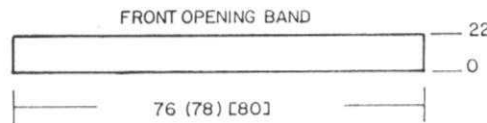

FRONT:

Work the front the same as the back to Row 212 (220) [228]. Begin to SHAPE ARMHOLE ON EACH SIDE same as the back BUT AT THE SAME TIME, after Row 222 (230) [238], bind off the center 8 sts., put the needles on the left into holding position and complete the right side first. *ON NECK SIDE bind off 2 sts. 2x, 1 st. 3x CONTINUING THE ARMHOLE SHAPING on the right (left for other side). After Row 293 (305) [317], SHAPE NECK: Bind off 5 sts. 1x, 2 sts. 1x, 1 st. 1x (2x) [3x]. After Row 330 (346) [362], SHAPE SHOULDER same as the back. Bring the needles on the left into working position, knit 1 row to the left side (WATCH PATTERN) and complete the left half. Follow the instructions from *.

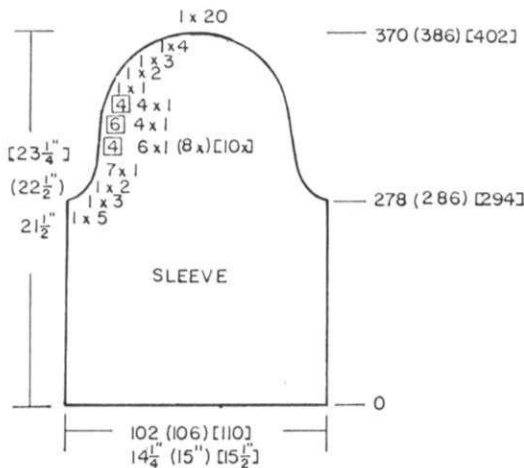

SLEEVES:

OPEN CAST ON with contrast waste yarn - 102 (106) [110] sts. Knit 9 to 11 rows then 1 row with Ravel Cord to the RIGHT then change to garment yarn and Counter at 0. Knit in Pattern to Row 278 (286) [294]. SHAPE CAP: ON EACH SIDE bind off 5 sts. 1x, 3 sts. 1x, 2 sts. 1x, 1 st. 7x then 1 st. every 4th row 6x (8x) [10x] then 1 st. every 6th row 4x, 1 st. every 4th row 4x, 1 st. 1x, 2 sts. 1x, 3 sts. 1x, 4 sts. 1x. After Row 370 (386) [402], bind off the remaining sts.

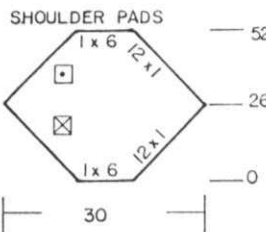

SHOULDER PADS:

Cast on 30 sts. and work Stockinette stitch with SHORT ROWS. ON OPPOSITE SIDE OF CARRIAGE, put into holding position 12 sts. before knitting the next 2 rows. ON OPPOSITE SIDE OF CARRIAGE, bring back into working position 1 st. 12x ON EACH SIDE. After Row 26, ON OPPOSITE SIDE OF CARRIAGE, put into holding position 1 st. 12x ON EACH SIDE. After Row 52, ON OPPOSITE SIDE OF CARRIAGE, bring all the needles back into working position on the next 2 rows then bind off all sts.

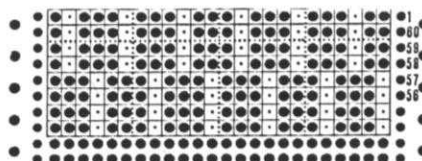

REPEAT THE PUNCH CARD THROUGH ROW 41 then punch 2 rows of holes for connecting card.

FINISHING:

Close side and sleeve seams. Set in Sleeves, gathering a bit at top. (See Picture). Make 2 twisted cords using 8 strands of yarn then attach at each front as shown. Close all hem openings. Fold shoulder pads in half and sew to inside shoulders.

Continued

KNITKING introduces

The Twister

A two-way Winder.

Twist your way to multi-color garments... Create your own original yarns by twisting your own selection of colors and textures. It will also wind a single strand of yarn into a ball.

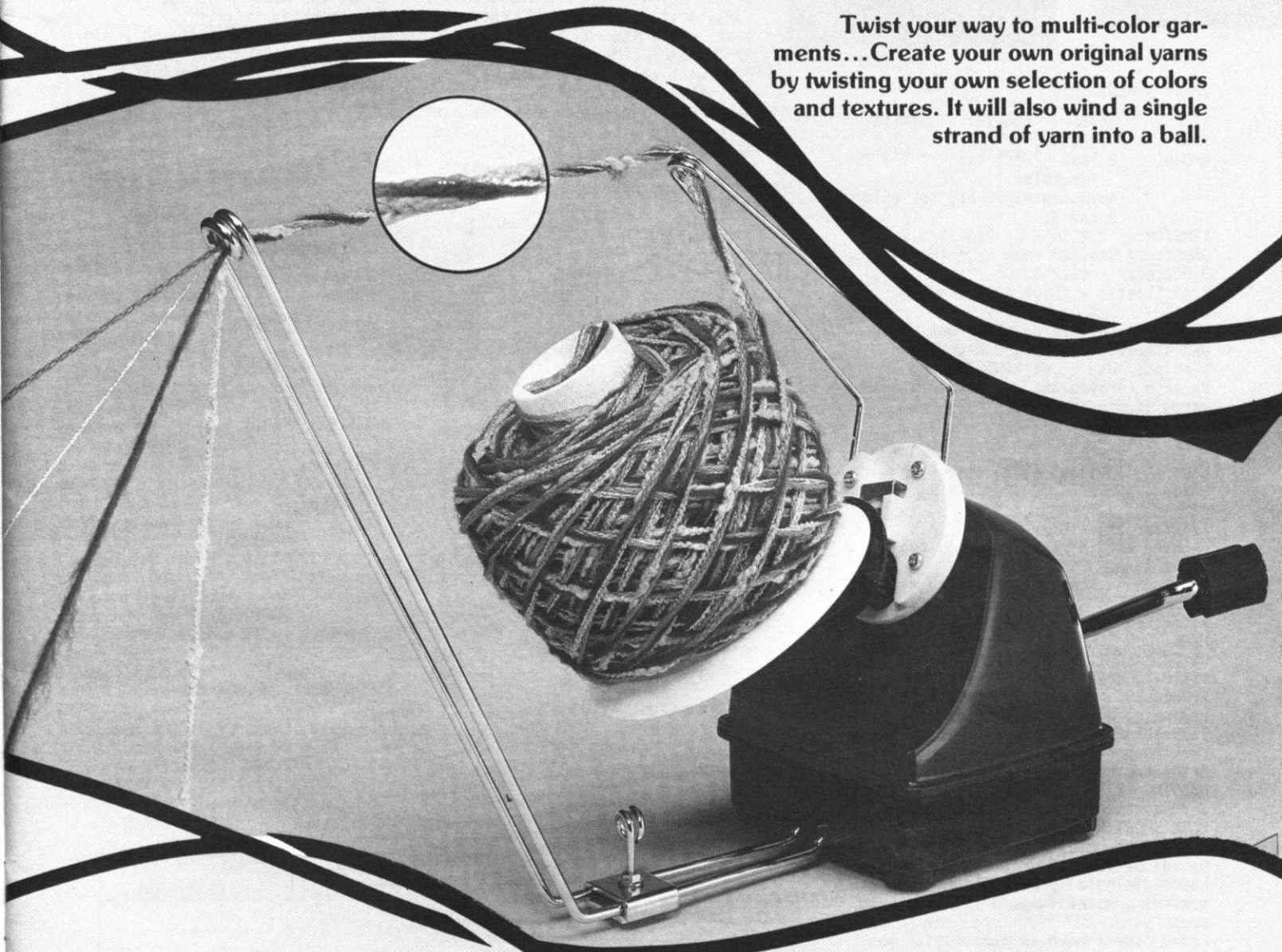

with Twister

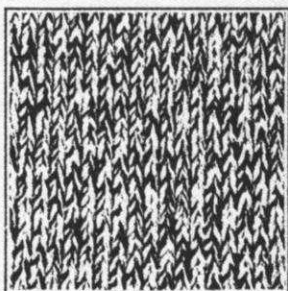

without Twister

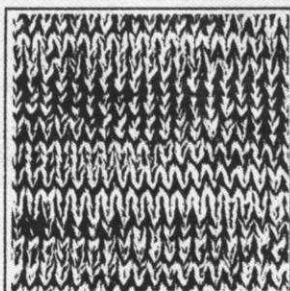

PRICE: \$27.95—California residents add
Sales Tax.
SHIPPING costs—\$2.50

Order direct from your dealer or from:
KNITKING, 1128 Crenshaw Blvd., Los Angeles, Calif. 90019

424

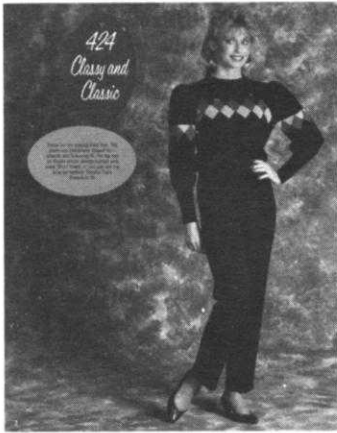

WOMAN'S PANT SUIT

SIZES: 6/8 (10/12) [14/16]
YARN: Venetia
AMOUNT 2 lbs. 2 1/2 lbs. 2 1/2 lbs.
 for color 1
 Approximately 2 oz. for color 2 and 3.

TENSION: 3.2 to 4.2 Rib. 1/0.2 II
GAUGE: 17 sts. 26 rows = 2" (5 cm)
 3 Buttons (1/2")
 3/4" Elastic - about 40" long.

An Argyle Pattern on the front, back and sleeves. Bands are K1, P1 Ribbing. Use SHORT ROWS for the Pattern (or you can use the Intarsia method if you prefer).

BACK:

Cast on 153 (165) [177] sts. with color 1 and work 40 rows K1, P1 Ribbing. Transfer the ribber sts. to main machine and increase 1 st. on the right side. Continue in Stockinette stitch with color 1.

After Row 152 (162) [168] MARK YOUR NEEDLE BED AS FOLLOWS: ON THE RIGHT, MARK NEEDLES 55 and 56, *SKIP 20 needles and mark the NEXT 2 NEEDLES. REPEAT FROM * 4x more. Beginning on the RIGHT SIDE, leave 21 (27) [33] needles in working position.

Bring the remaining needles into HOLDING (E) position. Set machine for holding needles. WORK SHORT ROWS on the left. Bring into holding position 1 st. 9x and be sure to wrap the inside needle in holding position to prevent a hole. Break yarn.

Leave these needles plus the all needles on the right and the 2 marked needles in holding position. *Bring the next 20 needles into working position and with color 1, WORK SHORT ROWS. ON EACH SIDE, bring into holding position 1 st. 9x. Break yarn, leave these in holding position plus the NEXT 2 marked needles. REPEAT FROM * 4x MORE. Bring the remaining needles to work and with color 1, work the Short Rows on the RIGHT only. Bring the Carriage to the right side.

ALL NEEDLES IN HOLDING POSITION with the exception of the first 2 MARKED NEEDLES on the right. With color 2, work SHORT ROWS. Bring back into working position (color 2) 1 needle OPPOSITE CARRIAGE 9x ON EACH SIDE, then work the holding short rows 1 needle 9x ON EACH SIDE. Break Yarn. REPEAT across the row in the same way, following the CHART BUT AT THE SAME TIME, after Row 172 (178) [184] SHAPE ARMHOLE: ON EACH SIDE, bind off 5 sts. 1x, 3 sts. 1x, 2 sts. 2x (3x) [3x], 1 st. 7x (7x) [9x], then 1 st. every 4th row 2x. AT THE SAME TIME, WORK THE SHORT ROWS with color 3 the same way as you did with color 2. When color 3 diamonds are completed. to back and with color 1, complete each section across filling in with INCREASE SHORT ROWS across in the same way.

Continue with color 1 when each section is completed. After Row 242 (254) [266], divide in the center, put the needles on the left into holding position and complete the right side first. *Knit to Row 266 (270) [290]. SHAPE NECK AND SHOULDER AT THE SAME TIME. FOR SHOULDER, bind off 5 sts. 5x 7 sts. 1x (6 sts. 5x, 4 sts. 1x) [6 sts. 6x,] FOR NECK, bind off 20 (22) [24] sts. then bind off 2 sts. 2x. Bring the needles on the left into working position. Knit 1 row to the left side, turn the Row Counter back to 242 (254) [266] and complete the left half. Follow the instructions from *.

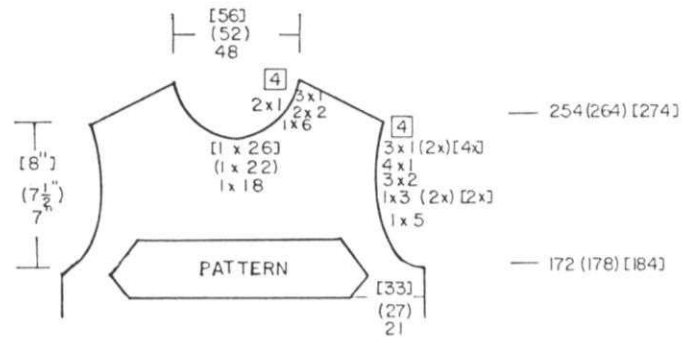
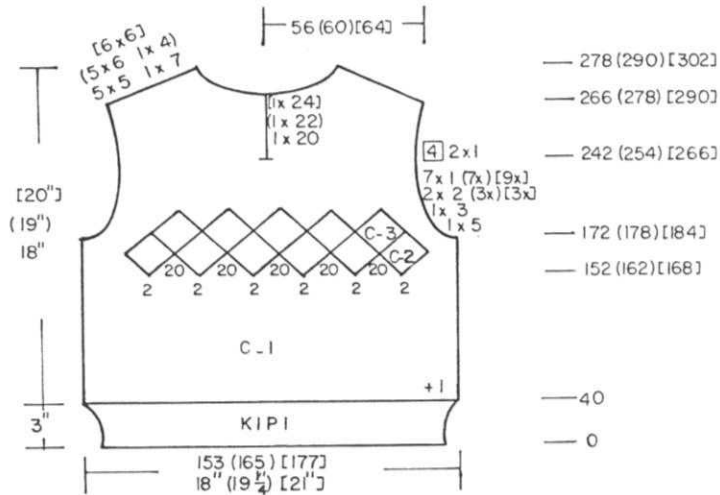

FRONT:

Work the front the same as the back with the exception of ARMHOLE SHAPING and NECK SHAPING. FOR ARMHOLE, after Row 172 (178) [184], ON EACH SIDE, bind off 5 sts. 1x, 3 sts. 1x (2x) [2x], 2 sts. 3x, 1 st. 4x, 1 st. every 4th row 3x (2x) [4x]. After Row 254 (264) [274], bind off the center 18 (22) [26] sts. put the needles on the left into holding position and complete the right side first.

*ON NECK SIDE, bind off 6 sts. 1x, 2 sts. 2x, 1 st. 3x, 1 st. every 4th row 2x, BUT AT THE SAME TIME, after Row 266 (278) [290] SHAPE SHOULDER SAME AS THE BACK. Bring the needles on the left into working position, knit 1 row to the left side, turn the Row Counter back to 254 (264) [274] and complete the left half. Follow the instructions from *.

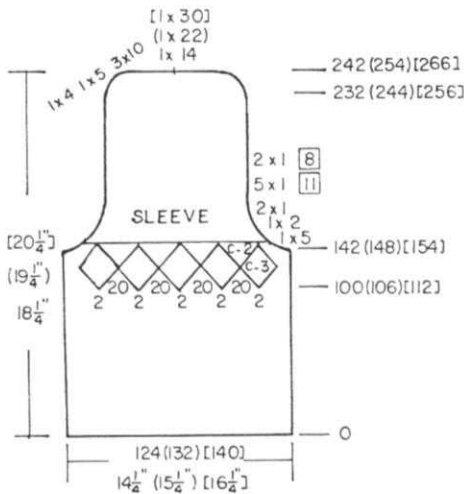

SLEEVES:

Cast on 124 (132) [140] sts. with contrast waste yarn. Knit 9 to 11 rows, 1 row with Ravel Cord to the right side. Counter at 0. With color 1, knit to Row 100 (106) [112]. Erase the markings you used on machine for front and back and replace them as follows. Mark needles 44 and 45 on the right side, *skip 20 needles and mark the next 2 needles and REPEAT from * across needle bed. Work the Argyle Pattern the same way as you did on front and back, but color 3 will have only half a pattern. See Chart. After Row 142 (148) [154] SHAPE CAP: ON EACH SIDE, bind off 5 sts. 1x, 2 sts. 1x, 1 st. 2x, 1 st. every 11th row 5x, 1 st. every 8th row 2x. After Row 232 (244) [256], bind off or work Short Rows ON EACH SIDE - 4 sts. 1x, 5 sts. 1x, 10 sts. 3x. After Row 242 (254) [266] bind off the remaining sts.

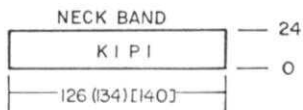

NECKBAND: Make 1 only.

Cast on 126 (134) [140] sts. with color 1 and work 24 rows K1, P1 Ribbing. Transfer the ribber sts. to main machine then with wrong side facing you and beginning at back neck opening, pick up sts. around neckline and hang onto these needles. Knit 1 row then bind off LOOSELY.

WRIST BANDS

Cast on 83 (89) [93] sts. with color 1 and work 90 rows K1, P1 Ribbing beginning with Tension 1/0.2 and INCREASING THE TENSION 1 notch every 12 rows ending with Tension 3/2.2. Transfer the ribber sts. to main machine then pick up the sts. of sleeve held on waste yarn with 1-2-1-2 sts. onto needles across. Knit 1 row, then bind off loosely.

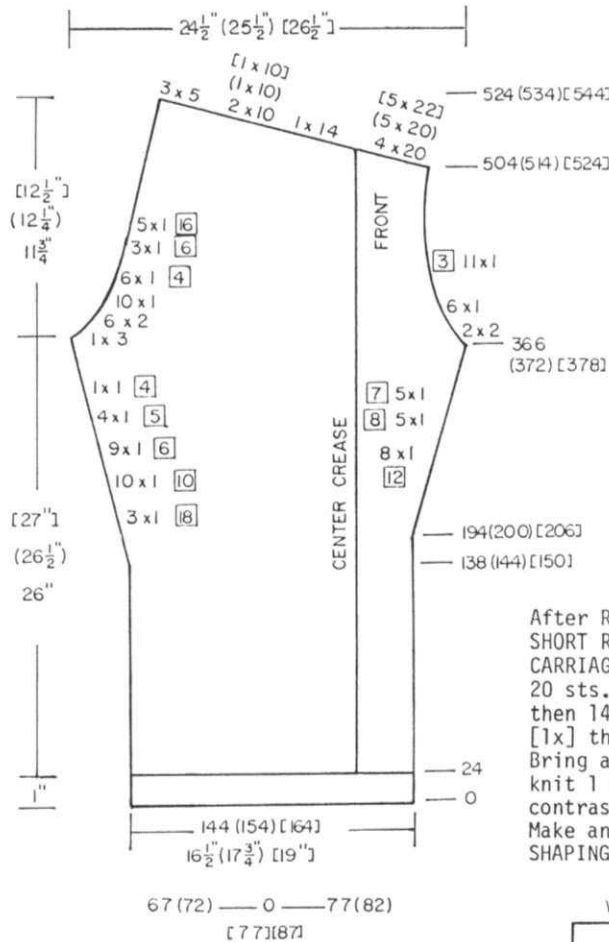
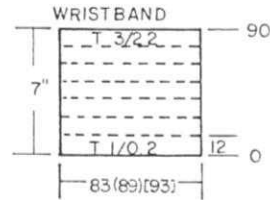

PANTS: MAKE 1, REVERSE 1

The Pants are knitted in two sections for the first two sizes. The LARGE SIZE MUST BE KNITTED IN FOUR PIECES because of limited number of needles. Divide the number of stitches in half and work separately. Cast on 144 (154) (164) sts. with color 1. Work Stockinette stitch. After Row 24, hang the hem. Knit to Row 138 (144) [150]. Begin the SHAPING on the LEFT followed by SHAPING on the RIGHT after Row 194 (200) [206]. Please follow the different shapings ON EACH SIDE as shown on the Chart. After Row 366 (372) [378], SHAPE CROTCH following the different shapings on each side as shown on the Chart.

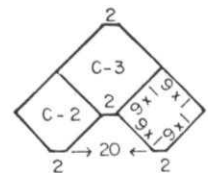

After Row 503 (513) [523], work SHORT ROWS: ON OPPOSITE SIDE OF CARRIAGE, put into holding position 20 sts. 4x (5x) [22 sts. 5x] then 14 sts. 1x, 10 sts. 2x (1x) [1x] then 5 sts. 3x. Bring all the needles into work, knit 1 row then remove the sts. onto contrast waste yarn. Make another section with REVERSE SHAPING.

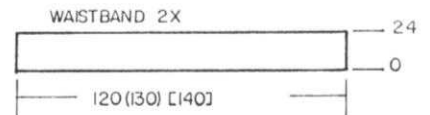

PANTS WAISTBAND: Make 2.

Cast on 120 (130) [140] sts. and work 24 rows Stockinette stitch. Hang the hem, then with wrong side facing you, hang half the sts. from waist onto these needles, knit 1 row then bind off loosely. Repeat for other half.

FINISHING: See General Instructions. **PANTS:** Sew crotch seams first then leg seams. Close waistband openings leaving 1 part open. Pull elastic through casing then close last seam. Work 1 row SLIP STITCH CROCHET down the center of each FRONT leg for crease. **PULLOVER:** Work single crochet around back neck opening making 3 loop buttonholes on the right edge then sew buttons to left side.

425



BOY'S PULLOVER

SIZES: 2/4 (6/8) [10/12]

YARN: Cordella & Mami Rex

AMOUNT:

color 1 3 4 4 balls
 color 2 1 ball for all sizes.
 color 3 1 ball for all size
 color 4 1 cone Mami Rex -USED DOUBLE.

TENSION 6 Rib. 1/1 II

GAUGE: 15 sts. 21 rows = 2" (5 cm)

Stockinette stitch with Fair Isle Designs. MADE ON THE KH 910 machine but can be made on any Electronic machine. Bands at waist and sleeve edges are K1, P1 Ribbing. Neckband is MOCK RIBBING with every 3rd needle out of work. Mark Designs on Mylar Sheet - Patterns A, B, C, D, E.

BACK:

Cast on 104 (112) [120] sts. with color 1 and work 32 rows K1, P1 Ribbing. Transfer the ribber sts. to main machine and knit 4 rows Stockinette stitch then continue in Fair Isle Patterns A, B, A. (See Chart). Continue in Stockinette stitch with color 1 to Row 126 (136) [146]. MARK EACH SIDE for setting in sleeves.

Knit in Patterns A, B, C, D, C then work Stockinette stitch with color 1

After Row 178 (188) [198], bind off the center 18 (22) [26] sts., put the needles on the left into holding position and complete the right side first.

*ON NECK SIDE, bind off 5 sts. 2x, 2 sts. 1x.

After Row 188 (198) [208], bind off the remaining sts. or remove them onto waste yarn.

Bring the needles on the left into working position, knit 1 row to the left side, turn the Row Counter back to 178 (188) [198] and complete the left half. Follow the instructions from *.

FRONT:

Work the front the same as the back to Row 36. Work Pattern A then 4 rows Stockinette stitch with color 1.

After Row 44, Work Pattern E then continue in Stockinette stitch to Row 126 (136) [146] with color 1.

Mark each side for setting in sleeves same as you did for back. Work Pattern A and after Row 138 (144) [150], divide in the center. Put the needles on the left into holding position and complete the right side first.

* Continue with Patterns B, C, D, C same as for back: BUT AT THE SAME TIME, ON NECK SIDE, decrease 1 st. every 2nd row 21x (23x) [25x].

After Row 188 (198) [208], bind off the remaining sts. or remove them onto waste yarn.

Bring the needles on the left into working position, knit in Pattern to the left side, turn the Row Counter back to 138 (144) [146] and complete the left half. Follow the instructions from *.

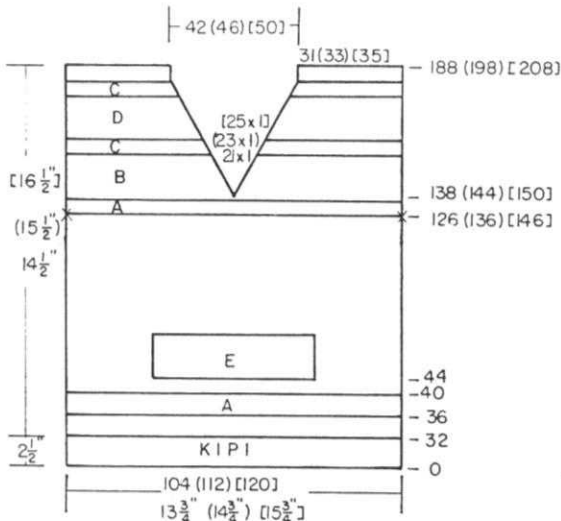
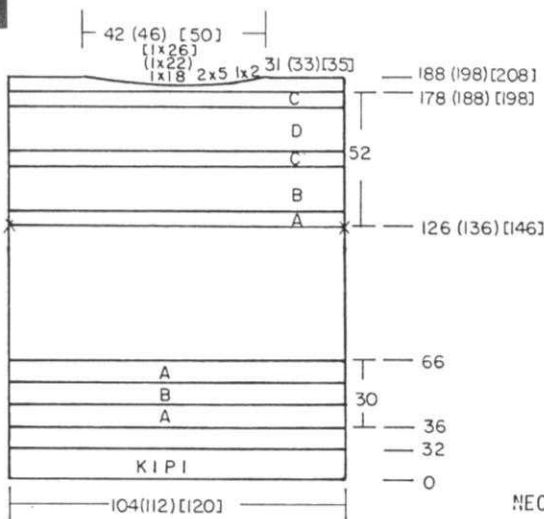

SLEEVES:

Cast on 53 (59) [67] sts. with color 1 and work 32 rows K1, P1 Ribbing. Transfer the ribber sts. to main machine and increase 1 st. on the right.

Knit 4 rows Stockinette stitch then work Patterns A, B, A BUT AT THE SAME TIME, ON EACH SIDE, increase 1 st. every 8th row 16x (17x) [18x] and when Patterns are completed continue in Stockinette stitch with color 1.

After Row 136 (140) [146], work Patterns A, B, A.

After Row 168 (172) [178], bind off.

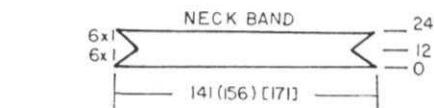

NECKBAND:

Bring 141 (156) [171] needles into working position, then push back to the out of work position (A) EVERY 3rd NEEDLE. Work in Mock Ribbing and ON EACH SIDE, DECREASE 1 st. every 2nd row 6x and CHANGE THE TENSIONS as follows: 4 rows tension 6, 4 rows tension 5, 4 rows tension 4. After Row 12, ON EACH SIDE, INCREASE 1 st. every 2nd row 6x, changing the tensions - 4 rows Tension 4, 4 rows tension 5, 4 rows tension 6. Hang the hem. After closing the shoulders, Pick up half the sts. from neck edge working from center V to center back. Knit 1 row then bind off. Pick up other half and knit 1 row then bind off.

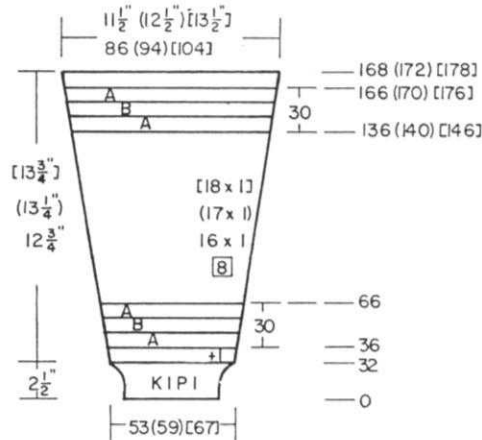

LOWER BACK AND SLEEVE PATTERN

PATTERN A - 4 Rows Color 1 & 4

4 Rows Color 1

PATTERN B 14 Rows Color 1 & 2

4 Rows Color 1

PATTERN A - 4 Rows Color 1 & 4

UPPER BACK & FRONT PATTERN

PATTERN A - 4 Rows Color 1 & 4

4 Rows Color 1

PATTERN B 14 Rows Color 1 & 2

4 Rows Color 1

PATTERN C - 4 Rows Color 1 & 4

4 Rows Color 1

PATTERN D 10 Rows Color 1 & 3

4 Rows Color 1

PATTERN C - 4 Rows Color 1 & 4

LOWER FRONT PATTERN

PATTERN A - 4 Rows Color 1 & 4

4 Rows Color 1

PATTERN E 25 Rows Color 1 & 4

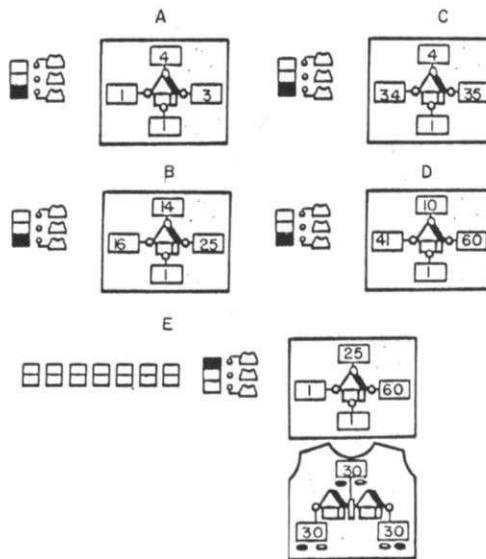

FINISHING: See General Instructions. Weave the sts. together at front V of Neckband.

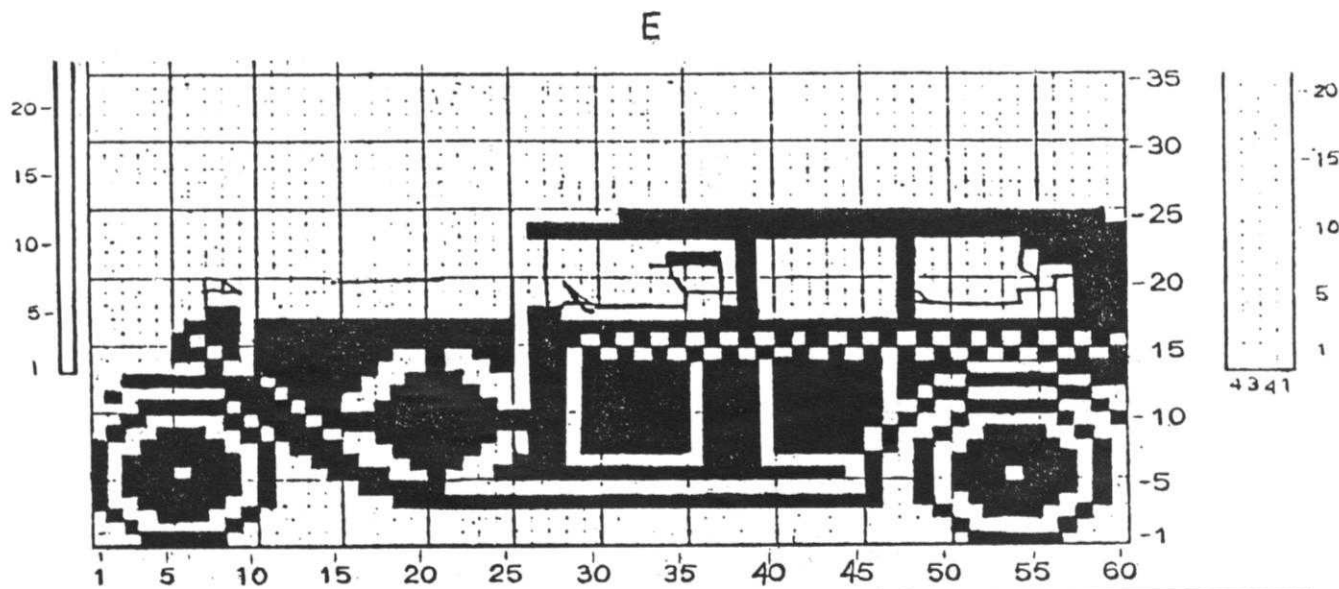
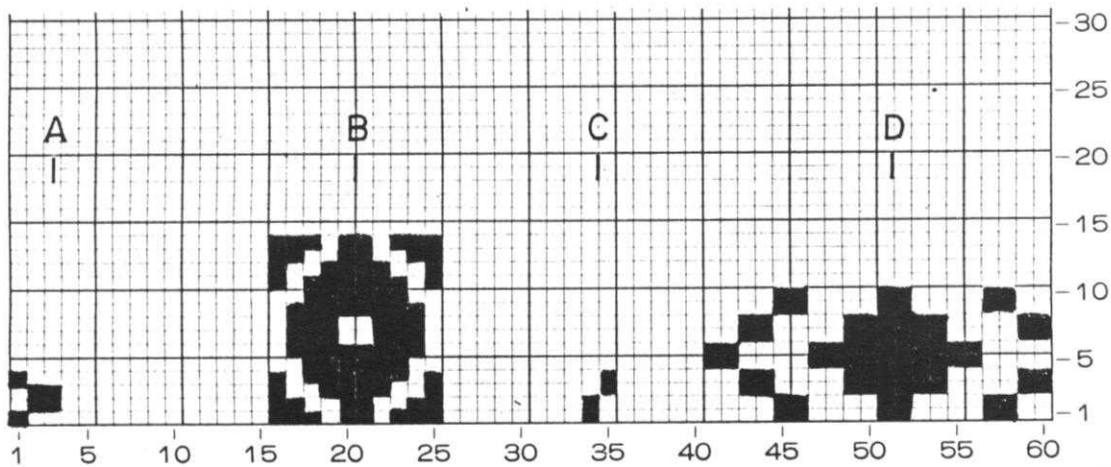

426

2 1/2 Cotton



WOMAN'S PULLOVER

SIZES: 6/8 (10/12) [14/16]
 YARN: Alanda
 AMOUNT: 7 8 8 balls
 TENSION: 9 to 10 - Rib. ten. 7
 GAUGE: 13 sts. 18 rows = 2" (5 cm)

MADE ON THE KH 910 machine using KG 88 ELECTRIC CARRIAGE.

BACK & FRONT THE SAME.

IMPORTANT INSTRUCTIONS.

Each time we tell you to RESET ROW COUNTER, you must set the Counter on the KG 88 Electric Carriage. When Counter reaches 0 (it goes backwards) the Carriage STOPS and you will then follow specific instructions and set the KG 88 Counter again.

'e' cast on 120 (128) [136] sts. Set KG 88 Carriage to 36 and Main machine Counter to 0. Work 36 rows K1, P1 Ribbing (See Practical Knitting Hints). Set KG Carriage to 2 and work Stockinette stitch (See Chart). Continue in Aran Isle Pattern (See Chart). Set KG Carriage for 6 rows. ON BOTH ORANGE AND GREEN SIDES OF MAIN MACHINE, mark needles 38 to 43 for CABLES.

After the 6 rows of Pattern, make the CABLES, crossing 3 and 3 marked stitches. ON THE LEFT side, cross right sts. first to the left needles, left sts. to the right. ON THE RIGHT cross the LEFT sts. first to the left, then right sts. to the left. Continue to make CABLES in the same way every 12 rows (Set KG Carriage each time). BUT AT THE SAME TIME, watch for Row 106 (114) [122] on MAIN MACHINE. Mark each side with bit of yarn for ARMBANDS. After Row 180 (192) [204], work SHORT ROWS for SHOULDER SHAPING. You MUST use a ravel cord for working short rows and knit the sts. with cord pulling them back to A (out of work position). ON OPPOSITE SIDE OF CARRIAGE, put 4 sts. 5x, 3 sts. 4x ON EACH SIDE onto Ravel Cord.

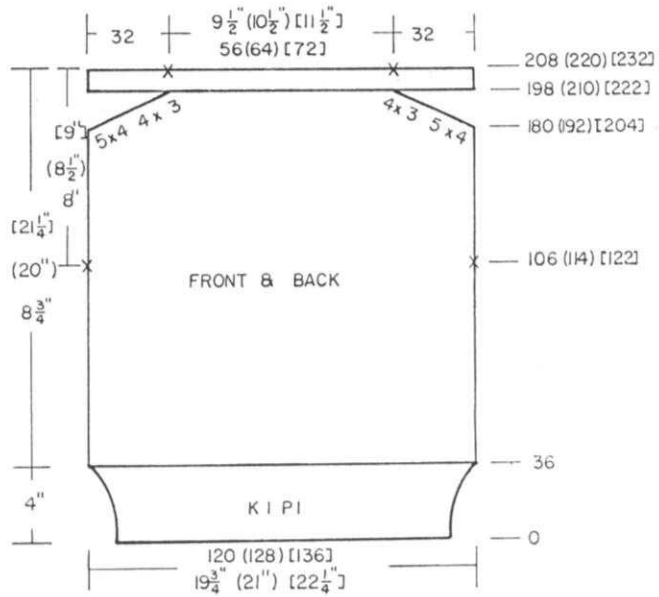

After Row 198 (210) [222] ON OPPOSITE SIDE OF CARRIAGE, pull on Ravel Cord to bring the needles back into working position. Pick up a stitch on edge below where holes would be (because of short rows) and hang it onto needle above to prevent a hole. Set Stockinette st. and knit across over all sts. to the left side. Bring the right side held needles into working position in the same way and stockinette st. to the right side. Mark the shoulder sts. on each side. Work 8 rows SEED STITCH (see Chart). Bind off shoulder and neck sts. separately. Make 2nd section the same.

ARMBANDS:

Sew up shoulders first. 'e' cast on 120 (128) [136] sts. Work 16 rows K1, P1 Ribbing, Ten. 6. Pick up sts. along marked edge of front and back then bind off loosely. REPEAT for other side.

FINISHING: See General Instructions.

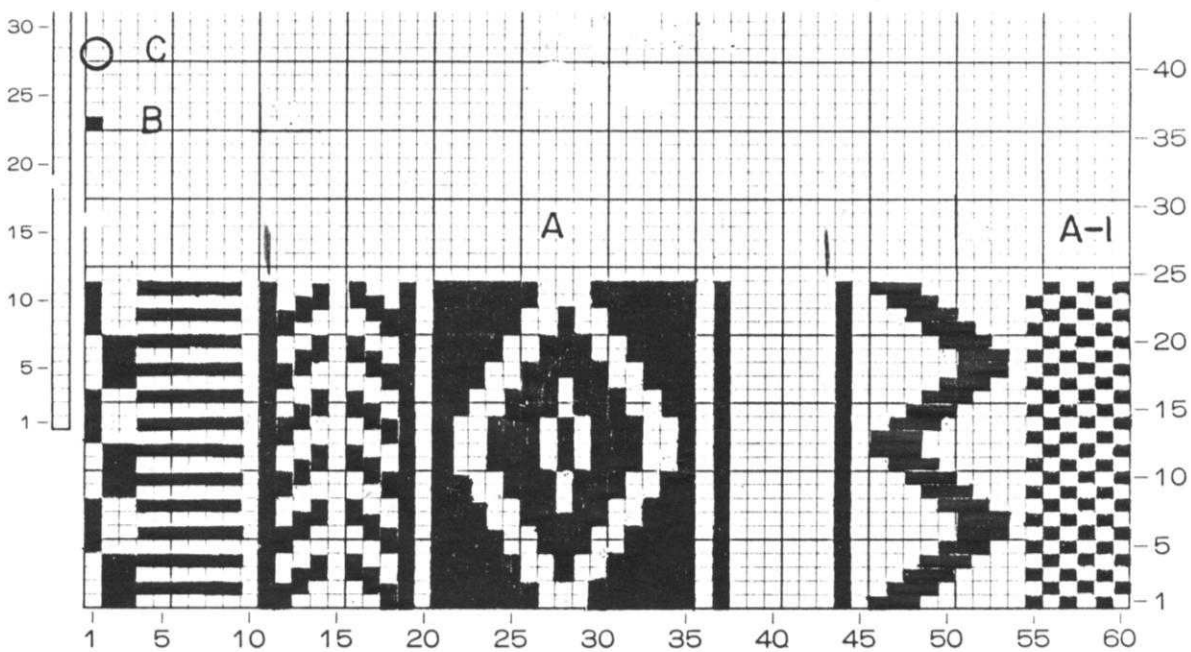

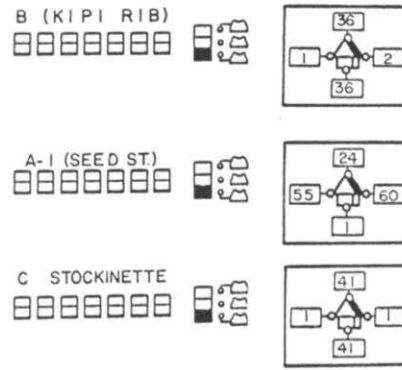
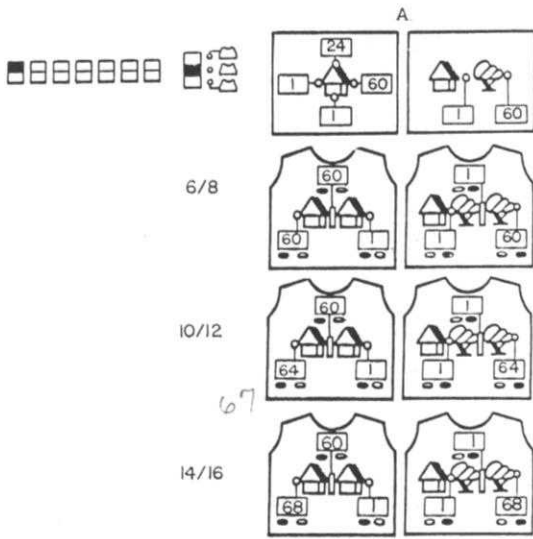

427

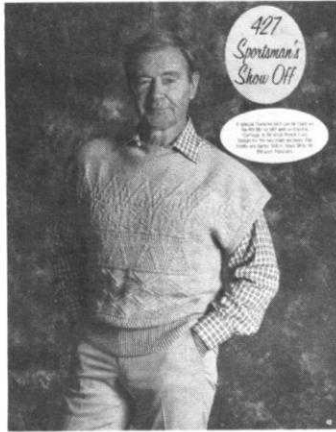

MAN'S SLEEVELESS PULLOVER

SIZES: 34/36 (38/40) [42/44]
 YARN: Alpacana
 GRAMS: 350 400 400
 TENSION: 8 - Ribbing 6
 GAUGE: 14 sts. 21 rows = 2" (5 cm)

Knitted on the KH 891 with Electric Carriage KG 89 or the KH 881 with KG 88 Electric Carriage.
 Punch Cards for Pattern No's 1, 2, 3. No 5 Pattern GARTER STITCH Card (No. 2) which is part of set for Electric Carriage.
 No. 4 Pattern is Seed Stitch and you should have a Card for this in your original set of Cards that came with your machine.

SPECIAL INSTRUCTIONS: - ON THE DRAWN CHARTS, the LEFT SIDE will show the actual number of rows to set on the Electric Carriage each time there is a Pattern change. The RIGHT SIDE OF CHART give you the ROW COUNTER NUMBERS for the MAIN MACHINE.

BACK AND FRONT: 2 sections the same.

Set KG 88 (89) Carriage onto machine. Insert and set K1, P1 Card. Bring 140 (150) [160] needles into working 'D' position then 'e' cast on into the HOOKS OF THE NEEDLES, each time bringing the needles back to 'B' (working) position. Line them up perfectly in 'B' position or Carriage will not work. Do not make the cast on too tight.

Set Row Counter of Electric Carriage to 32. Tension 6. Work: K1, P1 Ribbing.

When ribbing is completed, put Row Counter of main machine to 0. Connect Patterns 1 and 2. Set into machine and connect to revolve. Set KG Carriage Counter to Row 104. After Row 104, mark each side for setting in sleeves.
 Set KG Carriage Counter to 26. After Row 134, continue with the 60 rows of PATTERN 3 in the same way as you did before.
 After Row 194, continue with Pattern 4 for 26 (36) [46] rows. Machine Counter should say 220 (230) [240]. Work Pattern 5 for 16 rows.
 After Row 236 (246) [256], mark each shoulder as shown on the Chart. Bind off neck and EACH SHOULDER separately, making a LOOSE bind off.
 Make 2nd section the same.

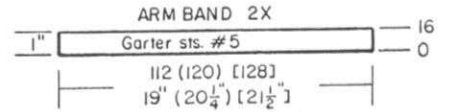

ARMBANDS: Make 2.

The Armbands are GARTER STITCH. Use Garter Stitch Card - Pattern 5. Work Garter stitch for 16 rows, casting on 112 (120) [128] sts. in the same way as you did for front and back.
 When band is completed, sew up shoulders first then hang onto machine with shoulder on center needle and EASE the sts. on each side from MARK TO MARK. Knit 1 row with loose tension then bind off.

FINISHING: Sew up side seams.

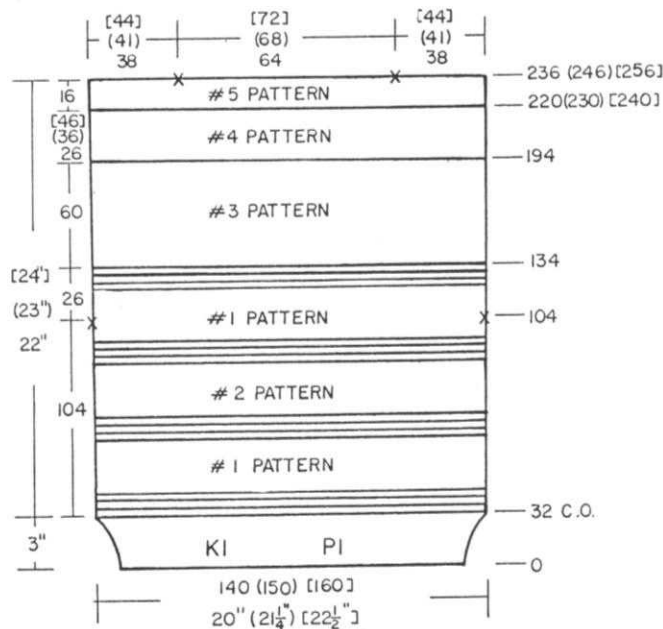

Continued

NO. 1

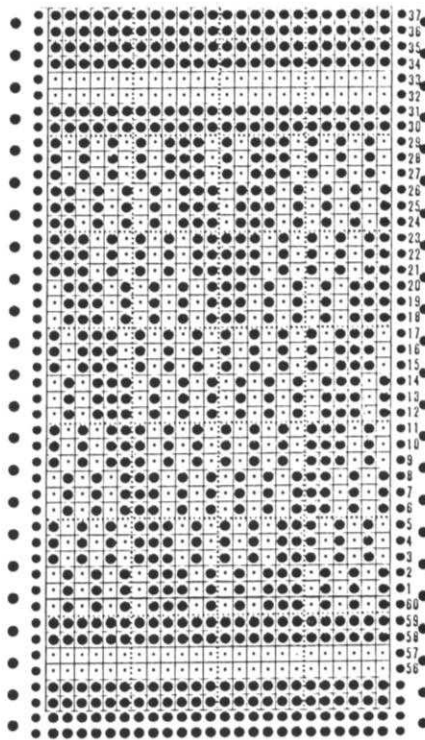

NO. 2

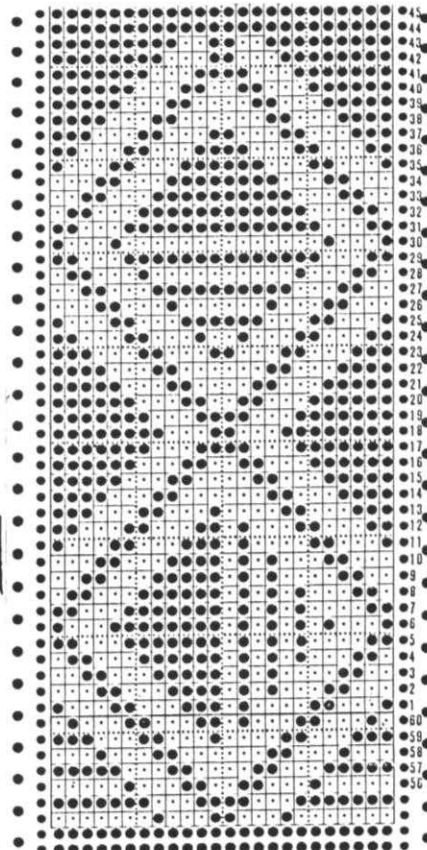

NO. 4

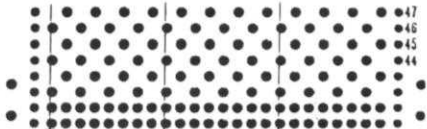

NO. 3

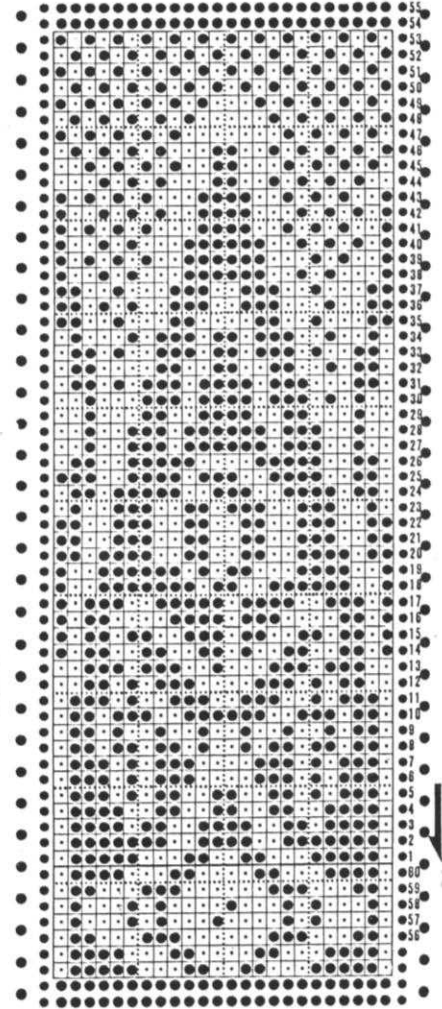

428



WOMAN'S COVER UP & PULLOVER

SIZES: Pullover = Small (Medium) [Large]
 Cover Up = Small/Medium [Large]

YARN: Venetia (thin) = color 1
 Venetia (thin) = color 2
 Angora = color 3
 Multi-Show = color 4

AMOUNT:

color 1	1 1/2	1 3/4	2 lbs.
color 2	3 oz.	4 oz.	5 oz.

Use left overs for color 2

color 3	6	6	7 balls
color 4	1	1	1 ball

TENSION: 4. for Tuck stitch & Lace
 6 for Angora
 Ribbing - 0/0 II

GAUGE: Tuck Stitch - 14 sts. 32 rows
 = 2" (5 cm)

If you wish to make a matching color skirt, order EXTRA Yarn (1 lb.) Venetia and make any Skirt from a KNITTING MAGAZINE.

The PURL side is the right side. Both Cover Up and Pullover has SPECIAL PATTERN INSTRUCTIONS. Be sure to watch the changes in Tension.

PULLOVER BACK:

With contrast waste yarn, cast on 68 (72) [76] sts. Knit 9 to 11 rows then 1 row with Ravel Cord to the right side. COUNTER AT 0 - change to color 1.

Knit 1 row to the LEFT then SET TUCK PATTERN.

Continue in Tuck Pattern to Row 38 (44) [50]. RELEASE TUCK BUTTONS. Knit 1 row Stockinette st. to the left. Hang some waste knitting (sometimes called cast-on Rag) onto 56 (59) [62] empty needles on the left. 'e' cast on over these new sts. and knit 1 row to the right.

Hang weights onto these new sts. * WORK THE 32 ROWS OF THE SPECIAL INSTRUCTIONS (the 1 row of hand knitting does not count).

Knit 2 rows Stockinette stitch, setting the TUCK PATTERN on the 2nd row. 36 (42) [48] rows of Tuck. Knit 2 rows Stockinette stitch. SEE PATTERN LINE DRAWINGS. AT THE SAME TIME, after Row 73 (79) [85] SHAPE NECK: Bind off 2 sts. 1x, 1 st. 3x. Continue in Pattern to Row 179 (197) [215]. ON NECK SIDE, increase 1 st. 3x, 2 sts. 1x. Continue in Pattern to Row 217 (235) [253]. Bind off 56 (59) [62] sts. Continue in Pattern to Row 258 (282) [306]- Remove onto contrast waste yarn.

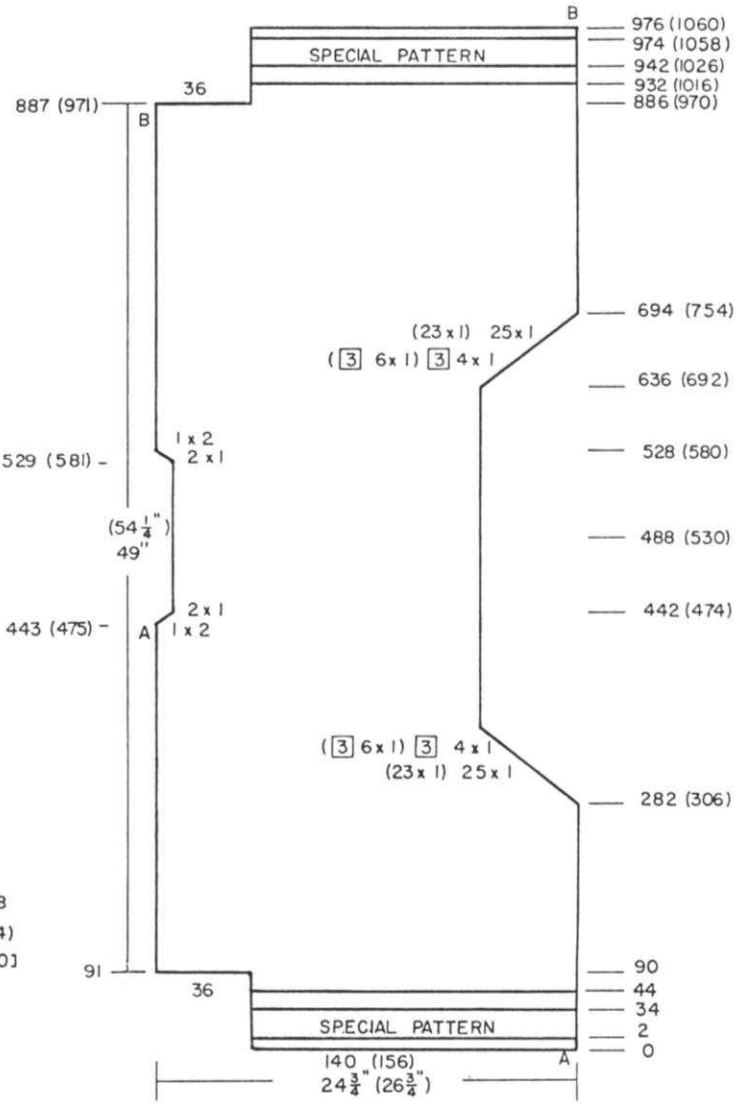
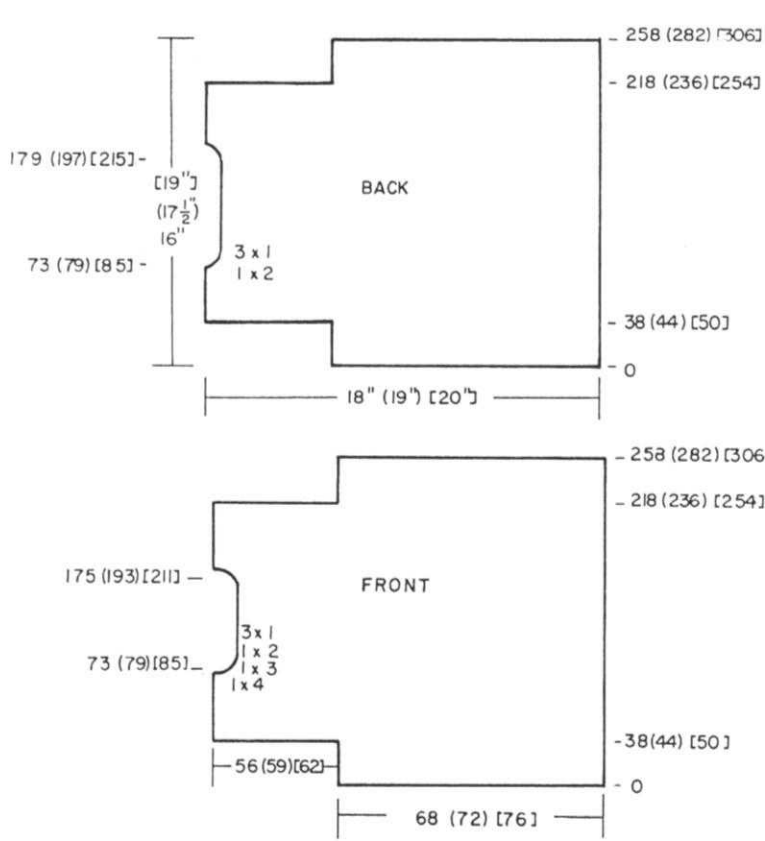

PULLOVER FRONT:

Work the front the same as the back with exception of NECK SHAPING: After Row 73 (79) [85] SHAPE NECK: Bind off 4 sts. 1x, 3 sts. 1x, 2 sts. 1x, 1 st. 3x. After Row 175 (193) [211] ON NECK SIDE, cast on 1 st. 3x, 2 sts. 1x, 3 sts. 1x, 4 sts. 1x. Continue same as the back and after Row 258 (282) [306], remove the sts. onto contrast waste yarn.

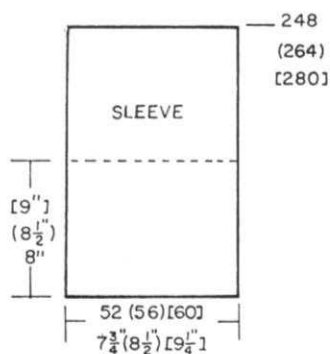

SLEEVE PATTERN

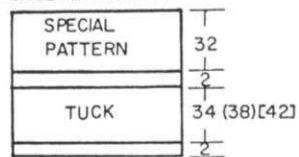

SLEEVE BANDS (make 2).

Cast on 90 (100) [110] sts. with color 1 and work 24 rows K1, P1 Ribbing. Transfer the ribber sts. to main machine then pick up sts. along lower sleeve edge and hang onto these needles. Bind off.

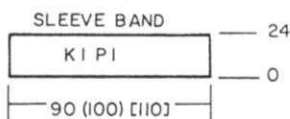

SLEEVES:

OPEN CAST ON SAME AS FOR BACK AND FRONT. 52 (56) [60] sts. Counter at 0 and change to color 1. Knit 1 row then set TUCK PATTERN from left to right. Work 34 (38) [42] rows of Tuck. Release Tuck buttons then work 2 rows Stockinette stitch. Work the SPECIAL INSTRUCTIONS. Knit 2 rows Stockinette stitch, setting the Tuck Pattern on the 2nd row. Continue in Pattern as shown on PATTERN CHART FOR SLEEVE to Row 248 (264) [280]. Remove the sts. onto contrast waste yarn.

WAIST BAND - Make 2.

Cast on 140 (150) [160] sts. with color 1 and work 32 rows K1, P1 Ribbing. Transfer the ribber sts. to main machine then pick up the sts. along back at waist and hang onto these needles. Bind off. REPEAT for front.

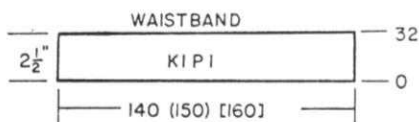

BODICE PATTERN

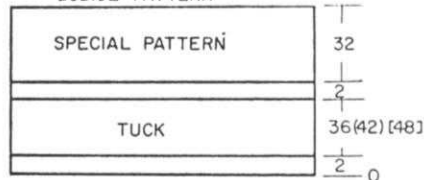

COVER UP:

With contrast waste yarn, cast on 140 (156) sts. After knitting 9 to 11 rows, knit 1 row with ravel cord to the right side. Change to color 1 and COUNTER AT 0. Knit 2 rows Stockinette st. WORK THE 32 ROWS OF SPECIAL PATTERN then work 10 rows Stockinette stitch, setting the TUCK PATTERN from left to right after the 9th row. Continue in Pattern. After Row 91, cast on 36 sts. on the LEFT SIDE. After Row 282 (306) increase 1 st. every 2nd row 25x (23x) then 1 st. every 3rd row 4x (6x). After Row 443 (475) SHAPE NECK: Bind off 2 sts. 1x, 1 st. 2x. Mark center of garment after Row 488 (530). After Row 529 (580) ON NECK SIDE, cast on 1 st. 2x, 2 sts. 1x.

CARD NO. 1 - LACE

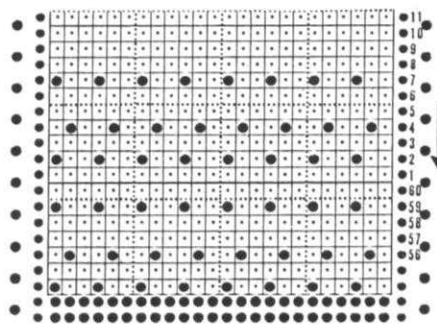

CARD NO. 2 - TUCK

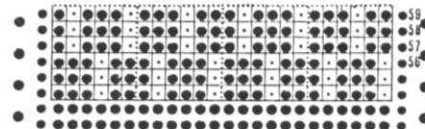

REPEAT the Punch Card through Row 53.

After Row 636 (692), increase 1 st. every 3rd row 4x (6x) then 1 st. every 2nd row 25x (23x). After Row 887 (971), bind off 36 sts (or remove onto waste yarn). After Row 932 (1016) STOP TUCK PATTERN. Work 10 rows Stockinette stitch then work the SPECIAL PATTERN INSTRUCTIONS. After Row 974 (1058), work 2 rows Stockinette stitch. After Row 976 (1060), remove the sts. onto contrast waste yarn.

SPECIAL PATTERN INSTRUCTIONS

- 4 Rows Angora with TENSION 6.
- 4 Rows Stockinette stitch color 3 - Tension 4.
- *Lace Carriage 2x, knit 2 rows.
- Lace Carriage 2x, knit 2 rows.
- Lace Carriage 4x, Knit 4 rows.*

With color 4, knit each stitch by hand, pulling the stitch back to A position. Carefully pull down on the knitting to bring the needles into B position (hang weights to prevent stitches from floating off). 4 rows Stockinette stitch color 3 REPEAT THE LACE FROM * TO *. 4 Rows Angora with TENSION 6.

FINISHING:

PULLOVER: - Sew shoulders and side seams. Sew in sleeves. With double color 2, work 1 row single crochet around neck then using Angora, work 1 row single crochet. COVER UP: Fold cast on edge A to A shoulder mark and bind off edge B to B shoulder mark then sew or slip stitch together. With double strand of color 1 work 2 rows single crochet around all edges and sleeve edges.



Change to color 1. WORK THE COLOR STRIPES WITH CHANGES IN TENSION AS GIVEN ABOVE, BUT AT THE SAME TIME, ON EACH SIDE increase 1 st. every 6th row 24x, every 3rd row 6x, then increase 1 st. every 2nd row 3x and cast on 3 sts. 1x.

After Row 170, MARK THE CENTER STITCH. Remove the sts. onto contrast waste yarn.

WOMAN'S DOLMAN SLEEVE PULLOVER

- SIZE: Medium
 YARN: Venetia = color 1
 Angora = color 2
 Capriccio = color 3
 AMOUNT: 1 lb. Color 1
 4 balls Color 2
 1 ball Color 3
 TENSION: 5.2 - Venetia - color 1
 7 - Angora - color 2
 4 - Capriccio - color 3
 GAUGE: 16 sts. 24 rows = 2" (5 cm) with Venetia

Stockinette stitch with color stripes. Bands are K1, P1 Ribbing. Knitted sideways on the machine, The knit side is the right side.

BEGIN AT SLEEVE EDGE.

COLOR STRIPES FOR SLEEVES.

- * 20 Rows color 1 Ten. 5.2
 - 2 Rows color 2 Ten. 7)
 - 2 Rows color 3 Ten. 4) PATTERN STRIPES
 - 2 Rows color 2 Ten. 7)
- REPEAT FROM * 5x.
 14 Rows Color 1 Ten. 5.2

With contrast waste yarn, cast on 84 sts. Knit 9 to 11 rows, then 1 row with Ravel Cord to the right side.

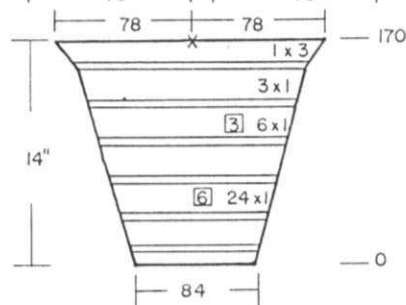
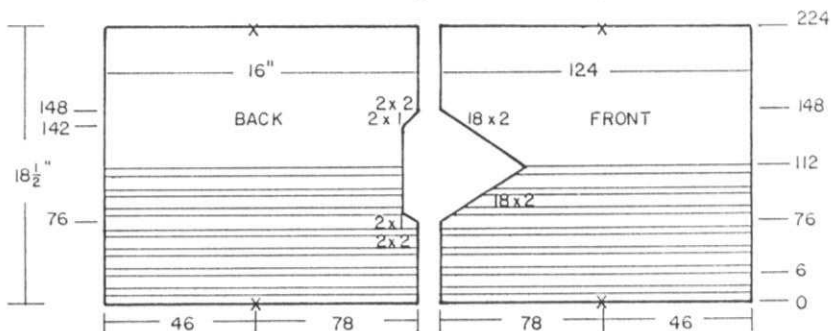
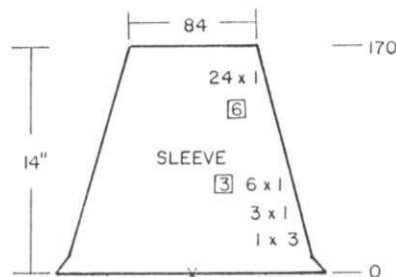

FRONT: - Bring 124 sts. into working position. Cast on 46 sts. on the right, then hang HALF THE SLEEVE STS. from mark on sleeve on the remaining 78 sts. (See Chart).
Work COLOR STRIPES as follows changing the Tensions as you did for sleeve.

6 Rows color 1
6 Rows PATTERN STRIPES
20 Rows color 1
6 Rows PATTERN STRIPES
14 Rows color 1
6 Rows PATTERN STRIPES
10 Rows color 1
6 Rows PATTERN STRIPES
6 Rows color 1
6 Rows PATTERN STRIPES
4 Rows color 1
*6 Rows PATTERN STRIPES
2 Rows color 1

REPEAT FROM * 2 time MORE
There should be 8 sets of Pattern Stripes - BUT AT THE SAME TIME after Row 75, SHAPE NECK.
Bind off 2 sts. 18x.

After Row 112 continue in Stock-inette stitch and ON NECK EDGE
After Row 112, continue with color 1 and on NECK EDGE, cast on 2 sts. 18x.
After Row 224, bind off 46 sts. on the right then remove the remaining 78 sts. onto contrast waste yarn.

BACK:

Bring 124 needles into working position, and with color 1, cast on over the 46 needles on the LEFT, from LEFT TO RIGHT. (Have Counter at 0 on the left to make it easier for you). Hang the 78 sts. from other half of sleeve onto the 78 needles.

Work the SAME PATTERN STRIPES as you did for the FRONT and be sure to change tensions.

AT THE SAME TIME, after Row 75 (neck side), bind off 2 sts. 2x, 1 st. 2x and after Row 141 ON NECK EDGE, cast on 1 st. 2x, 2 sts. 2x.

After Row 224, bind off 46 sts. then continue Sleeve over 156 sts. ON EACH SIDE, bind off 3 sts. COUNTER AT 0, THEN ON EACH SIDE decrease 1 st. 3x, then 1 st. every 3rd row 6x, then every 6th row 24x. After Row 170, remove the sts. onto contrast waste yarn.

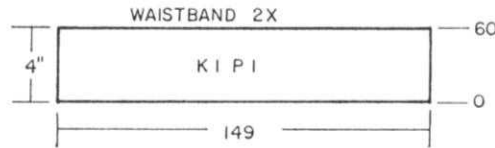

WAIST BAND: - Make 2.

Cast on 149 sts. with color 1 and work 60 rows K1, P1 Ribbing. Transfer the ribber sts. to main machine then hang waist edge of one section onto these needles. Knit 1 row and bind off loosely. Repeat for other half.

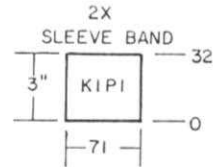

SLEEVE BANDS:- Make 2.

Cast on 71 sts. with color 1 and work 32 rows K1, P1 Ribbing. Transfer the ribber sts. to main machine then hang the open sts. of sleeve onto these needles. Knit 1 row and bind off loosely.

FINISHING:

Close shoulder, sleeve and side seams. Work single crochet around neckline using color 1 over color 1 and color 2 over color 2 edges.

**IT'S
READY
NOW...**

The new **KNITTING YARN CATALOGUE** with actual samples of all the gorgeous imported yarns we use for patterns in **KNITTING MAGAZINE**.

The colors are all new for 1984 and prepared for **KNITTING** by one of Europe's foremost yarn spinners.

For catalogue and price list send \$3.00 to:

KNITTING - 1128 Crenshaw Blvd.,
Los Angeles,
California 90019

**yarns by
KNITTING**

KNITTING - 1128 Crenshaw Blvd., Los Angeles, California 90019

430



Knit 2 rows with color 3 (Angora).
 For D Section, REPEAT A Short Rows with color 1.
 End with Carriage on the Left.
 Row 213 (223) [237].
 Knit 2 rows color 3 (Angora).
 For E Section, REPEAT A Short Rows with color 2 BUT AT THE SAME TIME, on the LEFT, mark Row 221 (233) [245] with a bit of contrast yarn for neck opening.
 End with Carriage on the Right side.
 Row 258 (272) [286].

Knit 2 rows with color 3 (Angora).
 For F section; REPEAT B Short Rows with color 1, ending with Carriage on the Right. Row 302 (318) [334].
 Remove 50 sts. on the right side onto contrast waste yarn.
 Knit 2 rows with color 3 (Angora).
 SHAPE SLEEVE with color 2.
 ON THE RIGHT, decrease 1 st. every 7th row 4x (every 6th row 5x) [every 6th row 6x].
 After Row 334 (354) [374], bind off the remaining sts.

WORK THE SECOND SECTION WITH REVERSE SHAPING, CASTING ON TO THE EXTREME RIGHT SIDE OF MACHINE.

WOMAN'S PULLOVER

SIZES: Small (Medium) [Large]
YARN: Venetia = color 1
 Multi-Show = color 2
 Angora = color 3

AMOUNT:
 color 1 1 lb. - USE 3 STRANDS
 color 2 4 balls for all sizes
 color 3 2 balls for all sizes
TENSION: 4 to 4.1 for Stockinette
 0/0 for Ribbing
GAUGE: 8 sts. 14 rows = 2" (5 cm)
 in Stockinette stitch.

Made on the KII 230 BULKY Machine but can be made on any Bulky machine. Knitted sideways on the machine using SHORT ROWS as shown on the Chart.

BACK & FRONT.- REVERSE 1.

To the EXTREME LEFT OF MACHINE, cast on 30 (33) [36] sts. with color 1. ON THE RIGHT SIDE, increase 1 st. every 7th row 4x (every 6th row 5x) [every 6th row 6x].
 Knit 2 rows with color 3 (Angora)
 Using WASTE KNITTING, cast on 50 sts. on the RIGHT (See Practical Knitting Hints this issue).
 With color 2, knit 1 row to the LEFT SIDE then work A section.
 Bring all the needles into holding (E) position.
 PUSH BACK INTO WORKING POSITION
 4 sts. 19x, 8 sts. 1x.
 (4 sts. 20x, 8 sts. 1x)
 [4 sts. 21x, 8 sts. 1x]
 BUT AT THE SAME TIME, mark Row 71 (77) [83] with a bit of yarn for neck opening.
 End with Carriage on the right side. Row Counter 76 (82) [88].
 Knit 2 rows with color 3 (Angora).
 Bring ALL needles into holding (E) position then work B section with color 1.
 Push back into working (B) position
 4 sts. 19x (8 sts. 1x
 (4 sts. 20x, 8 sts. 1x)
 [4 sts. 21x, 8 sts. 1x]
 Row 122 (130) [138]. Knit 2 rows Color 3. For C section, REPEAT B Short rows with color 2.
 End with Carriage on the Left side. Row 167 (177) [187].

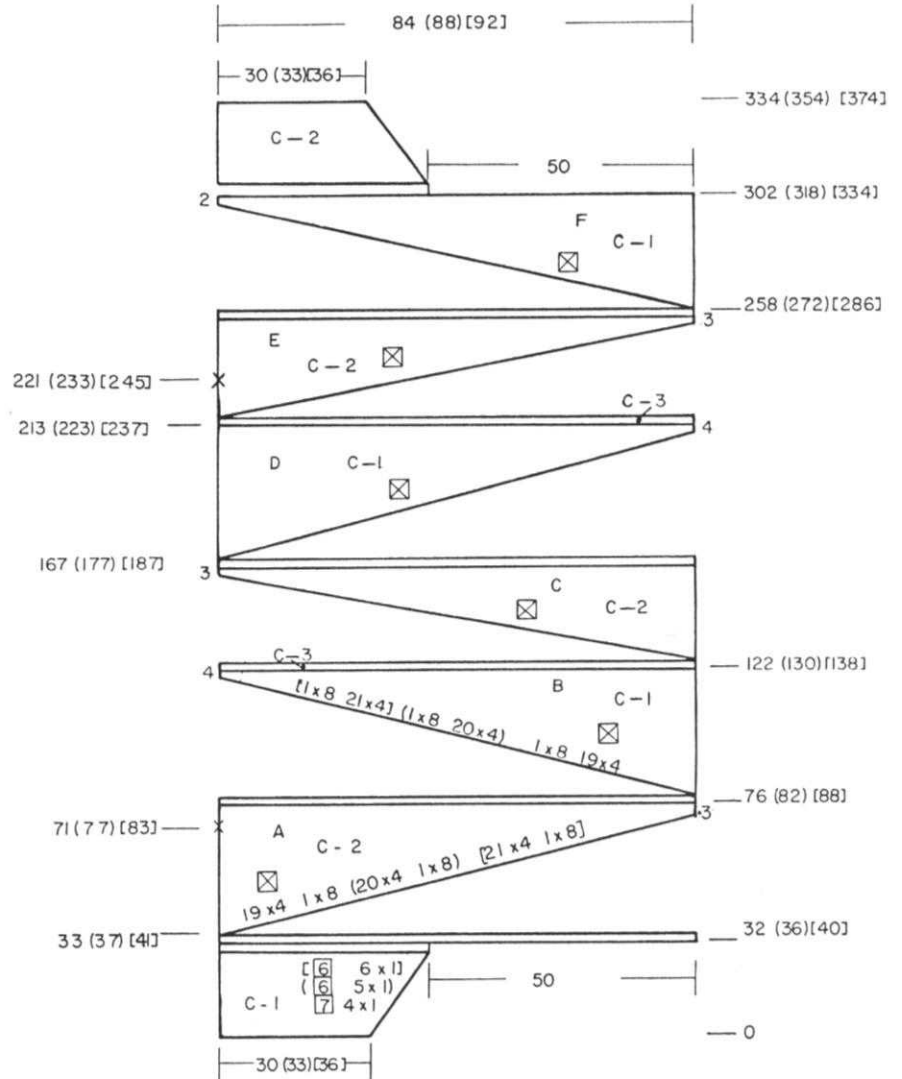

COLLAR - K1, P1 Ribbing.

Cast on 85 (89) [93] sts. with color 3 (Angora) and work 3 rows K1, P1 Ribbing Ten. 0/0. Change to color 1 and work
 10 Rows Tension 6
 10 Rows Tension 5
 10 Rows Tension 4
 10 Rows Tension 2.
 Knit 1 row with Ravel Cord and remove the sts. onto contrast waste yarn.

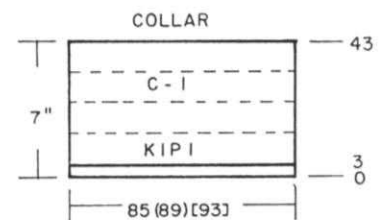

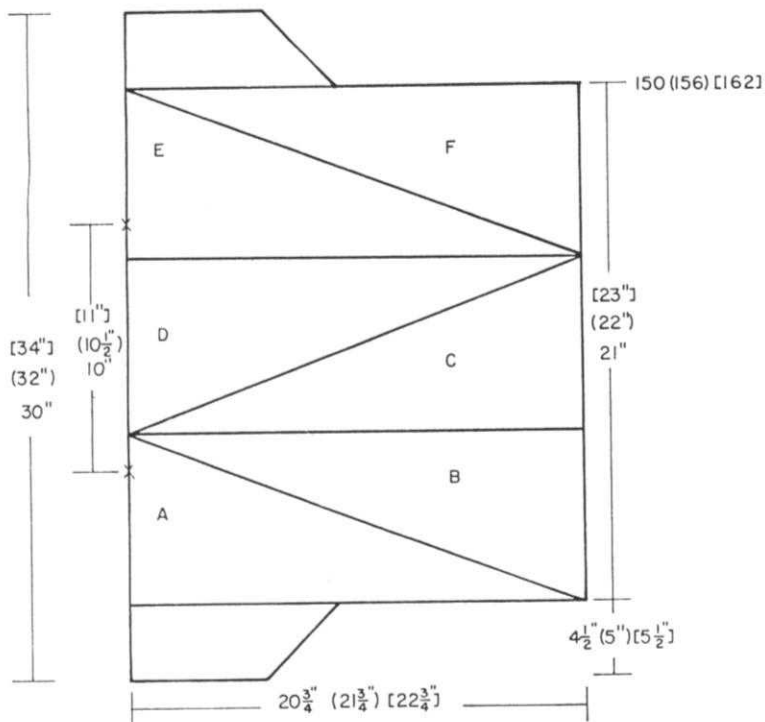

WAISTBAND - Make 2.

With color 1, cast on 69 (73) [77] sts. and work 30 rows K1, P1 Ribbing. Knit 1 row with Ravel Cord and remove the sts. onto contrast waste yarn.

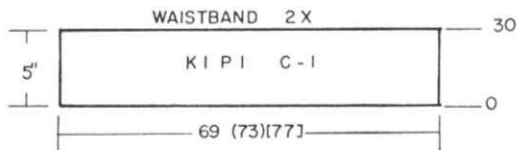

FINISHING:

Weave underarm seams. Single Crochet around sleeve edges. Fold Collar in half and pin to neck edge leaving mark to mark open for neck. Slip stitch crochet collar to neckline through the open stitches. Slip stitch waistband to lower edge in the same way.

431



WOMAN'S TWO PIECE SUIT

SIZES: 6/8 (10/12) [14/16]
YARN: Venetia (fine) = color 1
Multi-Show = color 2

AMOUNT:
color 1 2 1/2 lbs. for all sizes.
color 2 7 8 8 balls
TENSION: 3 to 4 -Rib. 0/0 II - 1/1 II
GAUGE: 17 sts. 21 rows = 2" (5 cm)
for Weaving Pattern.
TENSION 3.2 for SKIRT in Stockinette stitch.

The Skirt is knitted sideways on the machine with SHORT ROWS. The Jacket is a Weaving Pattern knitted OVER EVERY OTHER NEEDLE and worn on the PURL SIDE. EMPTY NEEDLES ARE COUNTED when increasing, or decreasing. Waistband of Jacket K1, P1 Ribbing. Punch Card.

IMPORTANT: Punch only 1 row of holes on Punch Card and leave Card on STOP. The Weaving Design is 2 rows Weaving, 2 rows Stockinette stitch. Even though needles are selected at all times, always knit 2 rows Stockinette stitch after 2 rows Weaving. Be sure to make a

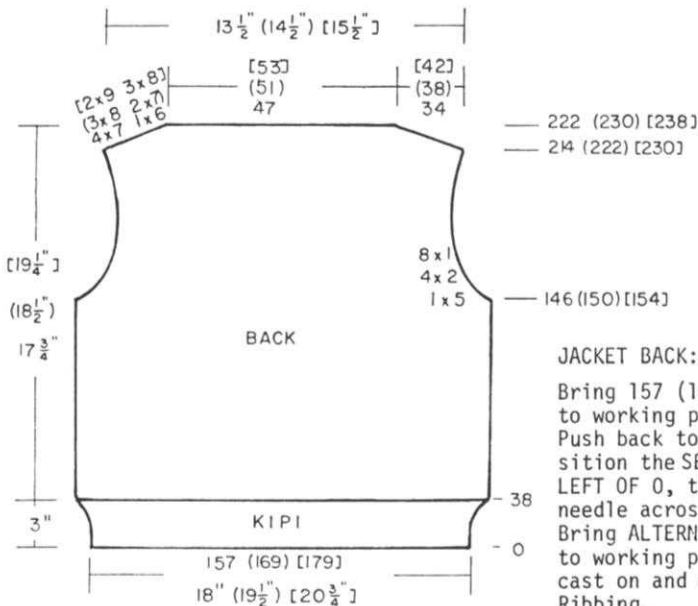

JACKET BACK:

Bring 157 (169) [179] needles into working position. Push back to out of work (A) position the SECOND needle to the LEFT OF 0, then every other needle across the needle bed. Bring ALTERNATE RIBBER NEEDLES to working position, then cast on and work 38 rows K1, P1 Ribbing.

sample first. Remember that the Pattern is knitted over EVERY OTHER NEEDLE. When increasing a stitch on the Jacket edges, bring NEXT empty needle into working position. You will have 2 stitches side by side on the edge then when making the NEXT increase, move that edge stitch over to next needle and push empty needle to A (out of work) position. When decreasing an edge stitch, move the edge stitch in to EMPTY NEEDLE (2 sts. side by side) push empty needle back to A position then the next decrease will be the edge st. to next st. and the following decrease to empty needle. Continue in this manner.

Transfer each Ribber stitch to the WORKING NEEDLES ON MAIN MACHINE (2 sts. on each needle). Knit 1 row to the left, then set Pattern before knitting 2nd row. Leave Card on Stop and work in Pattern. After Row 146 (150) [154], SHAPE ARMHOLES: ON EACH SIDE bind off 5 sts. 1x, 2 sts. 4x, 1 st. 8x. Knit to Row 214 (222) [230]. SHAPE SHOULDER: ON EACH SIDE bind off 7 sts. 4x, 6 sts. 1x. (8 sts. 3x, 7 sts. 2x). [9 sts. 2x, 8 sts. 3x]. After Row 222 (230) [238], bind off the remaining sts.

JACKET FRONT:

Bring 77 (83) [89] needles into working position then push back to the OUT OF WORK POSITION (A) the SECOND needle to the LEFT of 0 then every other needle across. Bring the alternate needles on Ribber to working position, then cast on and work 38 rows K1, P1 Ribbing. Transfer the Ribber sts. same as for back (to working needles) and continue in Weaving Pattern same as for BACK. After Row 147 (151) [155], SHAPE ARMHOLE: Bind off 5 sts. 1x, 3 sts. 1x, 2 sts. 4x, 1 st. 6x. After Row 196 (202) [208], SHAPE NECK: Bind off 8 (9) [10] sts. 1x, 5 sts. 1x, 3 sts. 1x, 2 sts. 1x, then every 4th row 1 st. 1x (2x) [3x]. After Row 215 (223) [231], SHAPE SHOULDER same as the back.

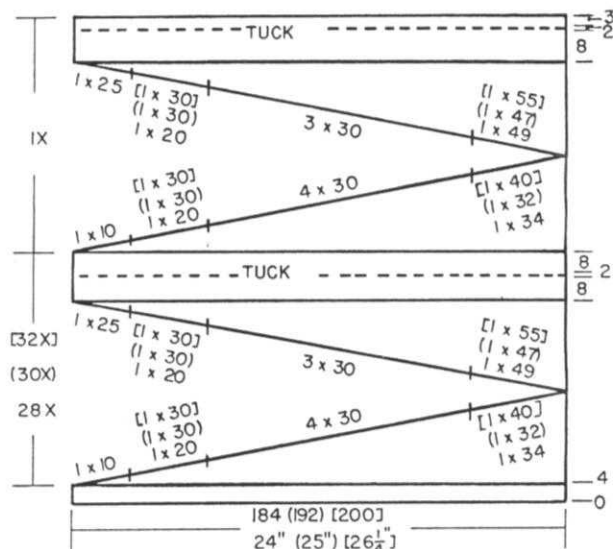
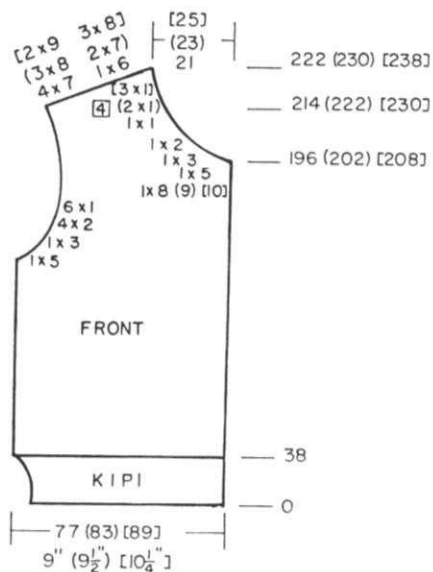

SLEEVES:

Bring 69 (75) [81] needles into working position then push back to the OUT OF WORK POSITION (A) the SECOND needle to the LEFT of 0 then every other needle across. Bring the alternate needles on Ribber to working position, then cast on and work 40 rows K1, P1 Ribbing. Transfer the Ribber sts. same as for back (to working needles) and continue in Weaving Pattern same as for BACK. ON EACH SIDE, increase 1 st. every 6th row 21x. After Row 172 (178) [184], SHAPE CAP: ON EACH SIDE, bind off 5 sts. 1x, 2 sts. 2x (3x) [4x], 1 st. 6x then every 4th row 1 st. 9x. ON EVERY 2nd row, decrease 1 st. 3x (4x) [5x], then bind off 2 sts. 2x, 3 sts. 1x, 4 sts. 1x, 5 sts. 1x. After Row 242 (252) [262], bind off the remaining sts.

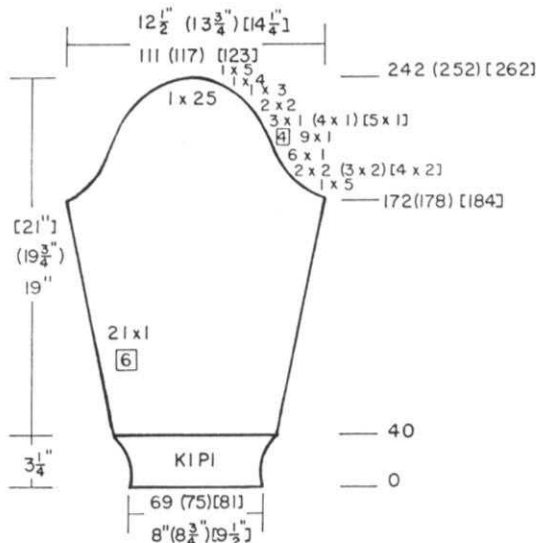

FINISHING: See General Instructions. With 2 strands of Venetia, work 4 rows single crochet around neck and front edges, working on the RIGHT SIDE and on the 3rd Row, make 11 BUTTONHOLES on the right front spacing them evenly. To make buttonholes, chain 2, skip 2 sts. On 4th row, single crochet into the chain sts.

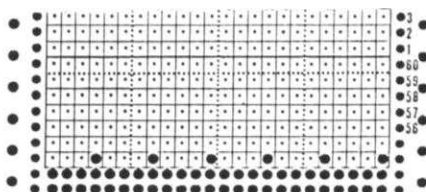
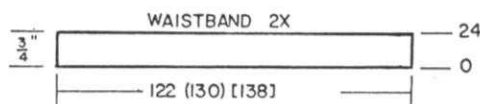

SKIRT: Ten. 3.2

With contrast waste yarn, cast on 184 (192) [200] sts. Knit 9 to 11 rows then 1 row with Ravel Cord to the Right side. Put Counter at 0 and continue in Stockinette stitch with SHORT ROWS and 1 Row of Tucking. You can use any every other needle Punch Card for the Tucking Rows. Leave the Card on STOP. Knit 4 rows.

* Work SHORT ROWS: ON OPPOSITE SIDE OF CARRIAGE, bring into holding position 10 needles 1x, then 20 (30) [30] needles 1x, then 30 needles 4x. Be sure to ALWAYS WRAP the inside needle in holding position or use the AUTOMATIC wrap. Bring back into working position 49 (47) [55] needles 1x then 30 needles 3x, then 20 (30) [30] needles 1x. KNIT 8 ROWS. SET TUCKING NEEDLES ON THE NEXT ROW, then work 1 ROW OF TUCKING. RELEASE TUCKING BUTTONS. Knit 8 rows. REPEAT FROM * 27 (29) [31] times more. End with 3 rows Stockinette stitch then remove the sts. onto contrast waste yarn.

WAISTBAND: MAKE 2

Hang HALF the skirt waist with wrong side facing you onto 122 (130) [138] needles and work 24 rows Stockinette stitch with tension 3. Hang first row of band and bind off LOOSELY. Make 2nd band.

FINISHING: Weave open sts. of skirt together then remove the waste knitting. Close opening on one side of band and pull elastic through casing then close band opening. Steam press pleats.

432



After Row 174 (186), SHAPE SHOULDER:
ON EACH SIDE, bind off
7 sts. 5x
(7 sts. 1x, 8 sts. 4x)
After Row 184 (196), bind
off the remaining sts.

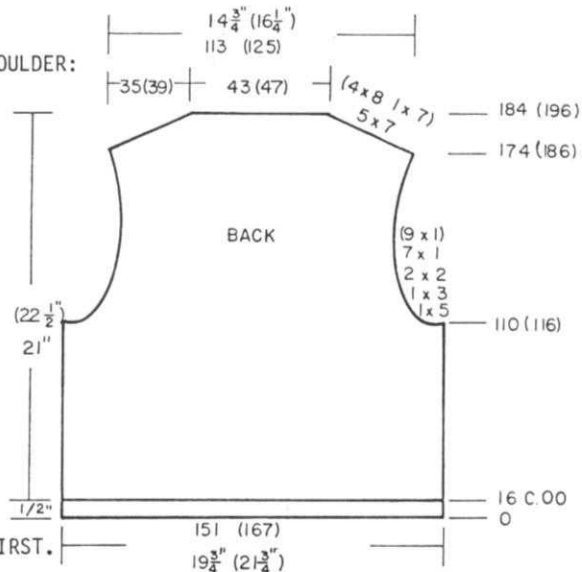
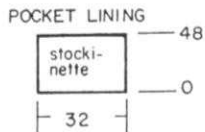

WOMAN'S TWO-PIECE SUIT

SIZES: 10/12 (14/16)
YARN: Venetia and Wool Tweed
AMOUNT: 2 1/2 2 1/2 lbs.
for Color 1 = Venetia
12 12 ozs.
for Color 2 = Wool Tweed
TENSION: 4 to 4.1
GAUGE: 15 sts. 17 rows = 2" (5. cm)

The Skirt Pattern is the same as Skirt No. 431.
For JACKET, use same Punch Card as No. 431. The Knit side of Weaving Pattern is the right side. Jacket is knitted over EVERY OTHER NEEDLE and the EMPTY needles ARE COUNTED when increasing or decreasing. Bands are knitted on every needle. Make SHOULDER PADS same as in Pattern No. 423. You will need 4 buttons for Jacket. Leave Punch Card on STOP.

IMPORTANT NOTE: When increasing a stitch on the Jacket edges, bring NEXT empty needle into working position. You will have 2 stitches side by side on the edge then when making the NEXT increase, move that edge stitch over to next needle and push empty needle to A (out of work) position. When decreasing an edge stitch, move the edge stitch in to EMPTY needle (2 sts. side by side) push empty needle back to A position then the next decrease will be the edge st. to next st. and the following decrease to empty needle. Continue in this manner.

BACK:

Cast on 151 (167) sts. with color 1. With Tension 3, knit 8 rows then 8 rows with Tension 3.2.
HANG THE HEM, knit 1 row to LEFT. BEGINNING with first stitch to the RIGHT of 0, hang this stitch onto next stitch then hang EVERY OTHER stitch to its neighboring needle across the machine. PUSH EMPTY NEEDLES BACK TO A (out of work) position. Set Punch Card on STOP - Knit 1 row to the right to SELECT NEEDLES. Counter at 0. WEAVING BRUSHES IN POSITION (down). Continue in WEAVING Pattern. Ten. 4 to 4.1. After Row 110 (116), SHAPE ARMHOLE - ON EACH SIDE, bind off 5 sts. 1x, 3 sts. 1x, 2 sts. 2x, 1 st. 7x (9x).

LEFT FRONT: MAKE POCKET LININGS FIRST.

Cast on 79 (87) sts. the same as you did for the back.
Knit 16 rows Stockinette stitch then hang the hem same as before and transfer the sts. as before so that you will work over every other needle. Set Punch Card from left to right and put Counter at 0. Continue in Pattern. WORK SHORT ROWS. ON OPPOSITE SIDE OF CARRIAGE, bring into HOLDING POSITION, 20 sts. Knit across and be sure to wrap inside needle in holding to prevent a hole. Knit back to the right side (left for 2nd half). ON OPPOSITE SIDE OF CARRIAGE, bring back to working position, 8 sts. 1x, 4 sts. 1x, 2 sts. 4x. After Row 34, skip 22 (26) sts. and remove the next 30 sts. onto waste yarn. Hang the POCKET LINING sts. onto the empty needles, hanging the end st. of lining onto each end st. on machine. Continue in Pattern to Row 103 (109) SHAPE FRONT: Decrease 1 st. every 3rd row 20x (22x), then decrease 1 st. every 4th row 4x. AT THE SAME TIME, After Row 110 (116), SHAPE ARMHOLE: Bind off 5 sts. 1x, 3 sts. 1x, 2 sts. 3x, 1 st. 6x (8x). After Row 174 (182), SHAPE SHOULDER same as the back. REVERSE RIGHT FRONT.

SLEEVES:

Cast on 69 (75) sts. and work the same as you did for back. Work 16 rows Stockinette same as for back then hang the hem and transfer the sts. as before so that you will work over every other needle. Set Punch Card from left to right and put Counter at 0. Continue in Pattern. ON EACH SIDE, increase 2 sts. every 10th row 11x. After Row 126 (132) SHAPE CAP ON EACH SIDE. Please follow the instructions for the bind offs as shown on the Chart. After Row 200 (210), bind off the remaining sts.

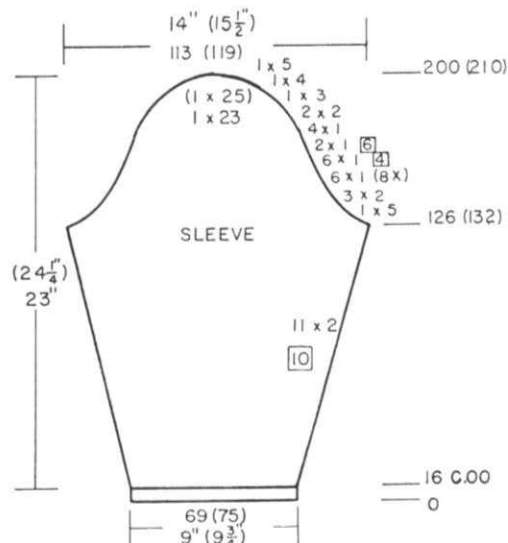
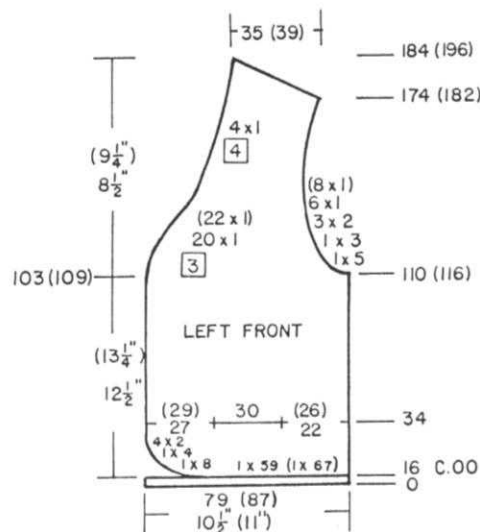

Continued

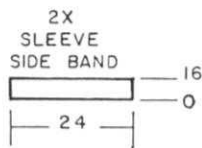

SLEEVE SIDE BANDS: (Make 2)

Cast on 24 sts. and work 16 rows Stockinette stitch same as back and front bands. Hang hem and bind off. Sew these bands to sleeves at wrist edge (for a false slit at outer arm edge) then sew buttons in place (See picture).

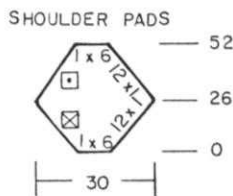
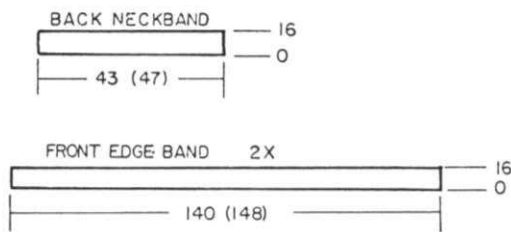

BACK NECK BAND

Cast on 43 (47) sts. and work 16 rows Stockinette stitch using same tension and method as bands for front and back. Hang the hem, then with PURL (wrong) side facing you pick up sts. from back neck of Jacket (3 sts. on each needle). Knit 1 row then bind off.

FRONT EDGE BANDS (Make 2).

Cast on 140 (148) sts. and work bands the same as back neck band.

FINISHING: See General Instructions. Make SHOULDER PADS same as No. 423 and sew in place.

433

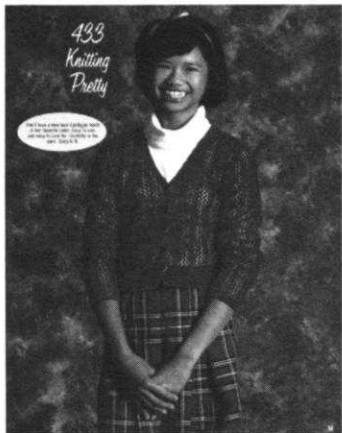

GIRL'S LACE CARDIGAN

SIZE: 6/8
YARN: Cordella
AMOUNT: 3 balls
TENSION: 6
GAUGE: 13 sts. 19 rows = 2" (5 cm)

A Lace Design with crochet edges. Punch Card.

BACK:

Cast on 82 sts. using the LATCH TOOL CAST ON for 3 rows. (SEE PRACTICAL KNITTING HINTS). Counter at 0. Knit in LACE Pattern to Row 90. SHAPE ARMHOLE: ON EACH SIDE, bind off 2 sts. 1x, 1 st. 2x, then 1 st. every 4th row 2x. Continue in Pattern to Row 152. Bind off the center 22 sts., put the needles on the left into holding position (back to A position with Ravel Cord) and complete the right side first. *SHAPE SHOULDER AND NECK AT THE SAME TIME. FOR SHOULDER, bind off 5 sts. 2x, 4 sts. 2x. FOR NECK, bind off 2 sts. 3x. Bring the needles on the left into working position and complete the left half. Counter at 152. Watch Pattern and follow the instructions from *.

FRONT: Make 1, reverse 1.

Cast on 42 sts. using the Latch Tool cast on same as you did for back. Counter at 0 and work LACE PATTERN to Row 90. SHAPE ARMHOLE same as the back BUT AT THE SAME TIME, SHAPE FRONT. ON FRONT EDGE decrease 1 st. every 3rd row 18x. After Row 152, SHAPE SHOULDER same as the back. Work 2nd front with reverse shaping.

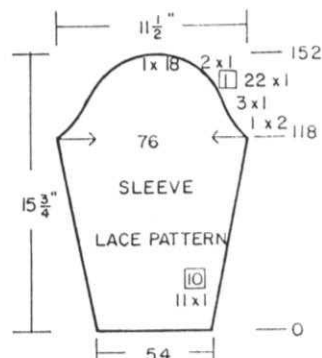

SLEEVES: Make 2.

Cast on 54 sts. using LATCH TOOL CAST ON same as you did for back and front. Counter at 0 and work in LACE Pattern. ON EACH SIDE, increase 1 st. every 10th row 11x. After Row 118, SHAPE CAP: ON EACH SIDE, bind off 2 sts. 1x, 1 st. 3x, 1 st. EVERY ROW 22x then 1 st. every 2nd row 2x. After Row 152, bind off the remaining sts.

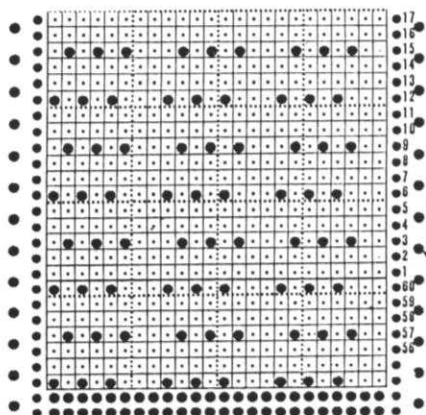
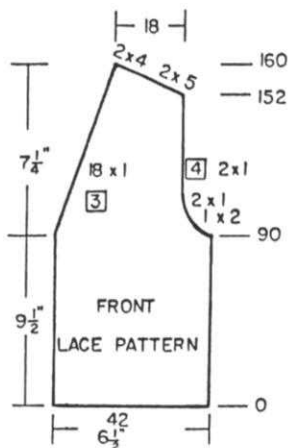
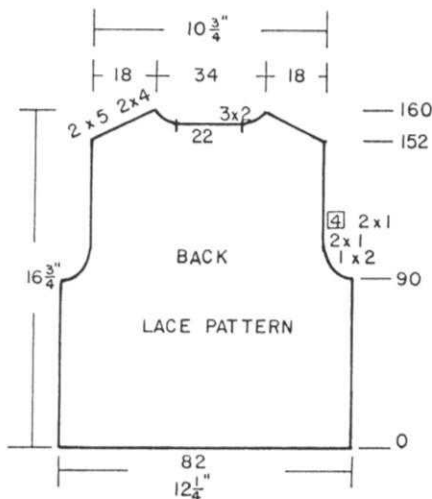

FINISHING: See General Instructions. Work 4 rows single crochet around all edges but on RIGHT FRONT ONLY, on the 3rd row, work 6 buttonholes evenly spaced down front. work 1 more row single crochet.

434



WOMAN'S HOUND'S TOOTH DRESS
SIZES: 6/8 (10/12) [14/16]
YARN: Venetia
AMOUNT:
 color 1 1 1/2 lbs. for all sizes.
 color 2 1 lb. for all sizes.
TENSION: 3.2 to 4 - Full needle
 Ribbing 5.1/5 II
GAUGE: 17 sts. 25 rows = 2" (5 cm).
 2 buttons for Belt
 1/2" Elastic for waist
 Shoulder Pads and 7" Zipper

A Fair Isle Pattern. Full needle Ribbing for bands. Punch Card.

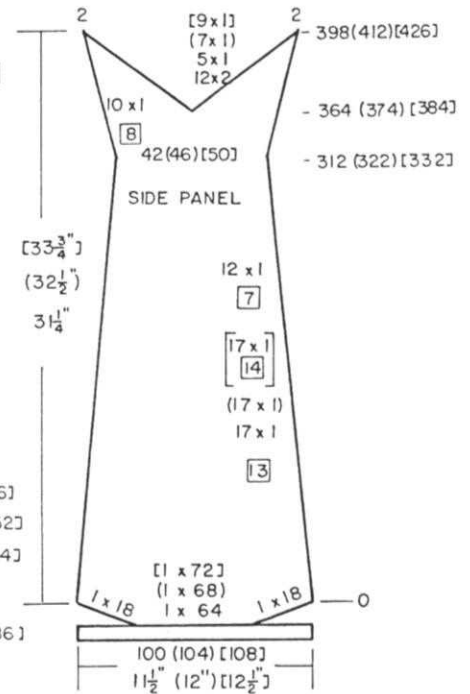

BACK: PANEL:

Cast on 150 (158) [166] with color 1 using RIBBER - FULL NEEDLE RIBBING so use all needles on BOTH BEDS. Knit circular - Move Carriage 9x ending on the right side. Use Tension 3.2/4 II for the circular knitting after the cast on row. Transfer the ribber sts. to main machine. Set Counter at 0. Garment Tension. Knit 1 row to the left. Set Pattern and knit 1 row to the RIGHT. Continue in Pattern and work SHORT ROWS. ON OPPOSITE SIDE OF CARRIAGE put into holding position 44 sts. beginning next 2 rows. Push back into working position 22 sts. 2x ON EACH SIDE.

Continue in Pattern. ON EACH SIDE decrease 1 st. every 13 rows 24x. After Row 312 (322) [332], MARK PUNCH CARD FOR BODICE/SHOULDER FOLD. ON EACH SIDE, increase 1 st. every 14th row 13x and AT THE SAME TIME, after Row 398 (412) [426], MARK EACH SIDE for setting in side Panels.

After Row 450 (468) [486], divide in the center for zipper opening and MARK ROW NUMBER ON CARD. Put the needles on the left into holding position and complete the right side first. Continue in Pattern.

*After Row 508 (526) [544], SHAPE SHOULDER: Bind off 6 (8) [10] sts. 1x, 7 sts. 5x BUT AT THE SAME TIME, after Row 515 (533) [551], SHAPE NECK: Bind off 20 (22) [24] sts. 1x, then 3 sts. 1x.

Bring the needles on the left into working position. Turn Card back to marked row for zipper opening. Card on STOP, Carriage on the LEFT SIDE, PART BUTTONS PUSHED IN. Set Pattern from left to right. Put Card on GO AND RELEASE PART BUTTONS. Knit 1 row in Pattern to the left side then turn the Row Counter back to 450 (468) [486] and continue in Pattern. Knit to Row 508 (526) [544] then complete the left half. Follow the instructions from *.

FRONT PANEL:

The front is worked the same as the back panel except for NECK SHAPING.

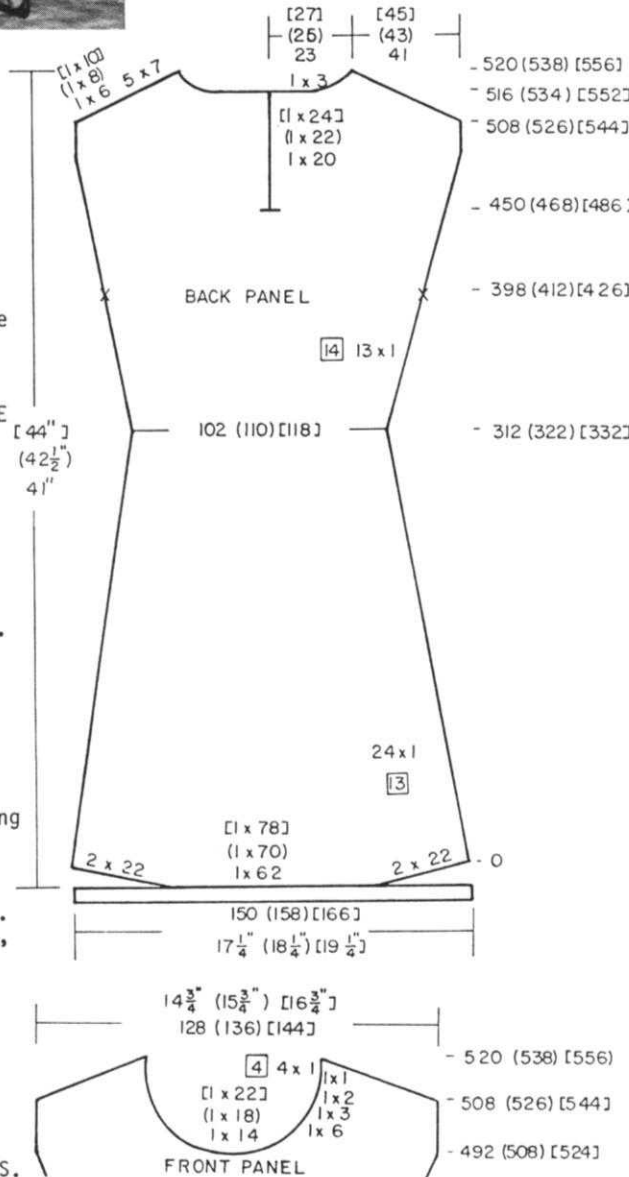

After Row 492 (508) [524], SHAPE NECK: Bind off the center 14 (18) [22] sts., put the needles on the left into holding position and complete the right side first. MARK ROW NUMBER ON PUNCH CARD. *ON NECK SIDE, bind off 6 sts. 1x, 3 sts. 1x, 2 sts. 1x, 1 st. 1x, then 1 st. every 4th row 4x, BUT AT THE SAME TIME, after Row 508 (526) [544] SHAPE SHOULDER same as the back panel.

SIDE PANELS: Make 2

FULL NEEDLE RIB same as back and front panels. Cast on 100 (104) [108] sts. After transferring the ribber sts. to main machine. Set Counter at 0. Knit 2 rows setting Pattern on 2nd row. WORK SHORT ROWS. Bring 18 needles into holding position before knitting the next 2 rows, then bring them back to working position on the next 2 rows. Continuing in Pattern, ON EACH SIDE, decrease 1 st. every 13 rows 17x (17x) [every 14th row 17x]. ON EACH SIDE, decrease 1 st. every 7th row 12x. After Row 312 (322) [332], ON EACH SIDE, increase 1 st. every 8th row 10x BUT AT THE SAME TIME, after Row 364 (374) [384], divide in the center. Put the needles on the left into holding position and complete the right side first. MARK THE ROW NUMBER ON CARD. *ON INNER EDGE, bind off 2 sts. 12x, 1 st. 5x (7x) [9x]. After Row 398 (412) [426], bind off the remaining 2 sts. Bring the needles on the left into working position, set Card and pattern in the same way as you did for front and back panels. Put Row Counter to 364 (374) [384] and complete the left half. Follow the instructions from *.

Bring the needles on the left into working position. Turn Card back to MARKED ROW for neck shaping. Carriage on the LEFT SIDE. Set Card and continue in the same manner as you did for Back Panel. Continue in Pattern following the instructions from *.

Continued

SLEEVES:

With contrast waste yarn, cast on 114 (120) [126] sts. After knitting 9 to 11 rows, knit 1 row with Ravel Cord to the right side, turn Row Counter to 0. With garment yarn, knit in Pattern. ON EACH SIDE, increase 1 st. every 4th row 30x, then 1 st. every 3rd row 7x. After Row 144 (152) [160], ON EACH SIDE, decrease 1 st. every 2nd row 13x (15x) [17x]. Bind off 2 sts. 5x. Bind off the remaining sts.

BELT:

FULL NEEDLE RIBBING with Tension 4.2/4.1. Cast on 22 sts. and work in Ribbing to Row 410 (430) [450]. Transfer the ribber sts. to main machine and bind off.

BODICE/SHOULDER BANDS: Make 4

TO THE LEFT OF 0 bring 6 (10) [14] needles into working position and to the RIGHT OF 0 bring 22 (18) [14] needles into working position. Cast on 28 sts. and work in Pattern. ON THE RIGHT SIDE, DECREASE 1 st. every 14th row 13x AND ON THE LEFT INCREASE 1 st. every 14th row 13x. After Row 198 (206) [214], bind off. Make a second band in the same way, then make 2 more with reverse shapings.

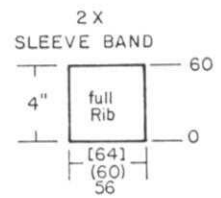
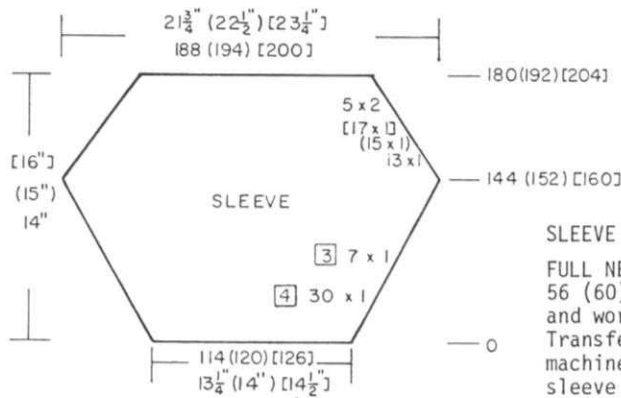

SLEEVE BANDS: Make 2.

FULL NEEDLE RIBBING. Cast on 56 (60) [64] sts. with color 1 and work 60 rows Ribbing. Transfer the ribber sts. to main machine then hang the open sts. of sleeve onto these needles. Knit 1 row then bind off loosely.

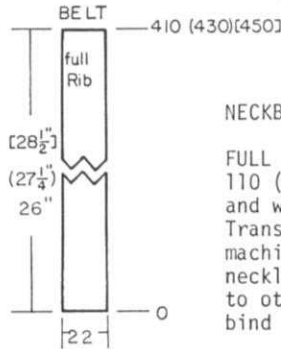

NECKBAND: Sew Shoulders first.

FULL NEEDLE RIBBING, Cast on 110 (120) [130] sts. with color 1 and work 22 rows Ribbing. Transfer the ribber sts. to main machine then pick up sts. around neckline from back neck opening to other side. Knit 1 row then bind off loosely.

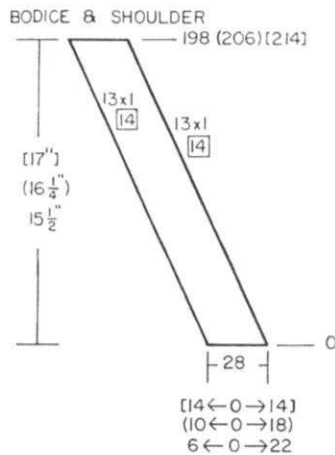
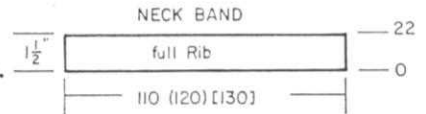

FINISHING: Match up and sew two sections of Bodice/Shoulder bands together. Fold in half and sew to side edges of front and back from waist to waist making sure the pattern matches. Sew on side panels to marked edges. Set in sleeves. Work 1 row single crochet around back neck opening then set in zipper. Make a crochet casing on the inside at waist level then pull elastic through casing. Sew in shoulder pads. Make 2 small buttonholes at 1 edge of belt using sewing machine or you can cut 1 thread, pull out 1 or 2 rows and buttonhole stitch around OR you can crochet loops at edges to fit buttons. Sew buttons to other side.

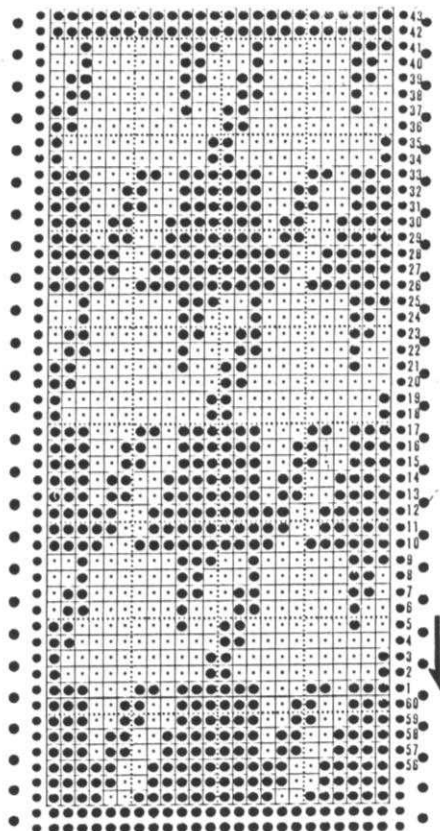

435



GIRL'S DRESS

SIZES: 2 (4) [6] <8>
 YARN: Amore
 AMOUNT: 4 4 5 5 balls
 TENSION: 5
 GAUGE: 14 sts. 24 rows = 2" (5 cm)

The Skirt is knitted in Stockinette stitch with SHORT ROWS. The bodice is a Lace Design. Punch Card.

MAKE SKIRT FIRST.

With contrast waste yarn, cast on 54 (62) [70] <78> sts. After knitting 9 to 11 rows, knit 1 row with Ravel Cord to the right side. Change to garment yarn and knit 4 rows. *WORK SHORT ROWS. ON OPPOSITE SIDE OF CARRIAGE, bring into holding (E) position 5 sts. 8x (6 sts. 8x) [7 sts. 8x] <8 sts. 8x> Then for all sizes 2 sts. 7x. Bring back into working position 2 sts. 7x for all sizes 5 sts. 8x (6 sts. 8x) [7 sts. 8x] <8 sts. 8x> Knit 10 rows.

REPEAT FROM * till 24x (26x) [27x] <28x> ending with only 6 rows stockinette stitch. Remove the sts. onto contrast waste yarn.

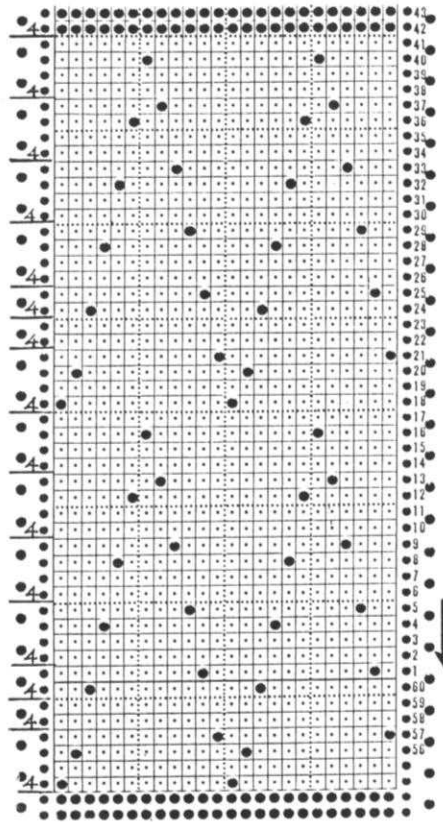

BACK & FRONT BODICE

Bring 66 (72) [78] <84> needles into working (B) position. With wrong side facing you, hang 1/2 Skirt waist onto these needles. Knit 2 rows. Transfer every 3rd st. to neighboring needle and leave empty needles in work. Knit 2 rows. Continue in Lace Pattern to Row 42 (46) [50] <54>. ON EACH SIDE, cast on 25 (27) [29] <31> sts. Continue in Lace Pattern to Row 90 (98) [106] <114>. Remove onto contrast waste yarn. Make 2nd section the same.

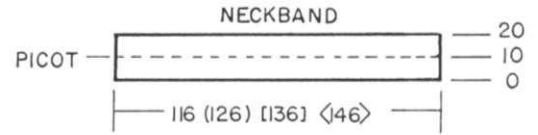
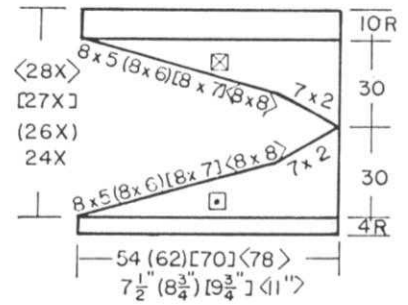

NECKBAND

Bring 116 (126) [136] <146> needles into working (B) position. With wrong side facing you, hang the sts. from front and back sections onto these needles, doubling every stitch. Knit 10 rows. Make Picot across over every 2nd needle. Knit 10 rows. Hang the hem and bind off loosely.

FINISHING:

Weave the open sts. of skirt together and remove waste yarn. Sew up shoulders and neckband. Single crochet around lower edge of skirt, or you can sew lace onto edge. Single crochet through open sts. for armhole and remove waste knitting.

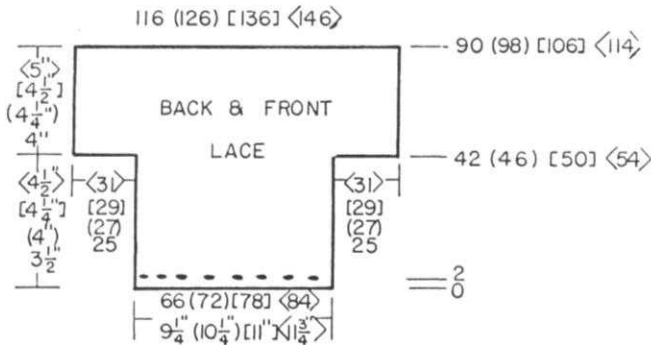

436



WOMAN'S PULLOVER

SIZES: Small (Medium) [Large]
YARN: Multi Show-Color 1
Angora - Color 2

AMOUNT:
color 1 10 11 12 balls
color 2 1 1 1 ball
TENSION: 5 5.2 6.1
Ribber -0 -0 -0
for circular cast-on
2/2 2.1 2.2
2.1 2.2

GAUGE: 8 sts. 12 rows = 2" (5 cm)
for small size.

FRONT and BACK the same EXCEPT for out of work needles on the front.

Cast on 72 sts. and work 20 rows K1, P1 Ribbing. Transfer the Ribber sts. to main machine and continue in Stockinette stitch.

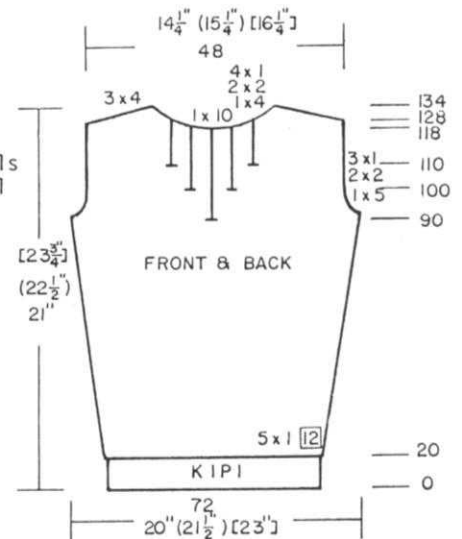

Continued

ON EACH SIDE, increase 1 st. every 12th row 5x.
 After Row 90, SHAPE ARMHOLE and begin the front neck Design. Remove the center stitch onto strand of yarn (tie to hold) and push empty needle back to A (out of work) position.
 AT THE SAME TIME, ON EACH SIDE, bind off
 5 sts. 1x, 2 sts. 2x, 1 st. 3x.
 After Row 100, 110, ON EACH SIDE, leave 3 sts. then REMOVE the 4th st. onto strand of yarn as you did before and put empty needles out of work.
 After Row 118, bind off the center 10 sts., put the needles on the left into holding position and complete the right side first.
 *ON NECK SIDE, bind off 4 sts. 1x, 2 sts. 2x, 1 st. 4x and after Row 128, SHAPE SHOULDER, bind off 4 sts. 3x.
 Bring the needles on the left into working position, knit 1 row to the left side, turn the Row Counter back to 118 and complete the left half. Follow the instructions from *.

Work the BACK the same as the FRONT but OMIT the out of work needles.

SLEEVES:

Cast on 38 sts. and work 20 rows K1, P1 Ribbing.
 Transfer the ribber sts. to main machine and continue in Stockinette stitch.
 ON EACH SIDE, increase 1 st. every 7th row 11x.

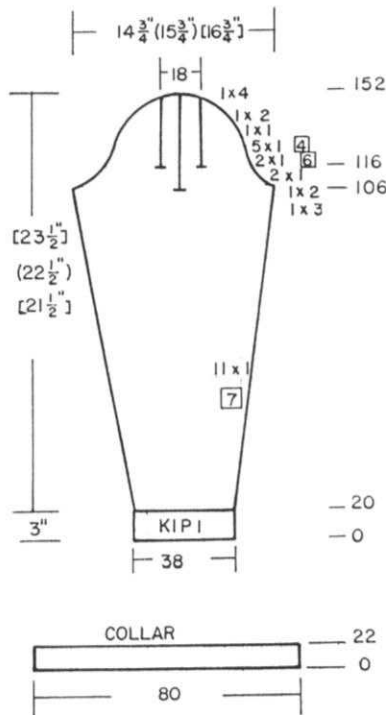

After Row 106, remove the center stitch onto strand of yarn and tie to hold. Push empty needle to out of work position (A)
 SHAPE CAP: ON EACH SIDE, bind off 3 sts. 1x, 2 sts. 1x 1 st. 2x, 1 st. every 6th row 2x BUT AT THE SAME TIME, after Row 116, remove the 4th st. ON EACH SIDE OF CENTER st. onto strand of yarn as you did before and push the empty needles out of work and CONTINUE THE CAP SHAPING ON EACH SIDE.

Decrease 1 st. every 4th row 5x, then 1 st. every 2nd row 1x, 2 sts. 1x, 4 sts. 1x.
 After Row 152, bind off the remaining stitches.

COLLAR:

Sew up 1 shoulder first.
 With wrong side facing you, hang the neck onto 80 needles from OPEN shoulder to shoulder. Knit 22 rows Stockinette stitch. Bind off LOOSELY. Allow the collar to curl to the right side.

TASSELS: Make 3.

Cut 10 strands of Angora 8" in length for each tassel.
 Fold in half and with garment yarn, tie in center of 10 strands then wind yarn about 8x below the fold, approximately 1" down. Knot ends and hide under the winding.
 With Angora and working from the RIGHT SIDE, pick up the stitch held on yarn and with crochet hook or latch tool, crochet over each strand of the open stitches (see picture). Attach 1 tassel to center. REPEAT the Angora crochet for each ladder and attach tassel to each outside trim (see picture).

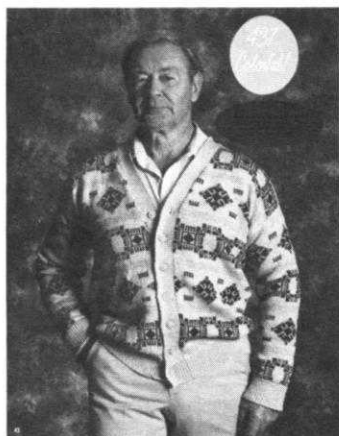

437

MAN'S CARDIGAN

SIZES: 38/40 (42/44)

YARN: Beatrice

color 1 7 balls both sizes.

color 2 5 balls both sizes.

color 3 2 balls both sizes.

TENSION: 6 Rib. 1/1 II

GAUGE: 17 sts, 21 rows = 2" (5 cm)

A Norwegian Design using 3 colors.
 Bands are K1, P1 Ribbing.
 Follow the instructions for Design along side 910 Pattern Sheet. MADE ON THE KH 910 machine.

BACK:

Cast on 172 (180) sts. with color 1 and work 32 rows K1, P1 Ribbing. Transfer the ribber sts. to main machine. Work 4 rows Stockinette stitch with color 1 then continue in Pattern. Knit to Row 260 (268). Bind off the center 30 (32) sts., put the needles on the left into holding position and complete the right side first.
 MARK PATTERN ROW on Pattern Sheet.
 *ON NECK SIDE, bind off
 5 sts. 1x, 4 sts. 1x, 3 sts. 1x, 1 st. 1x.
 After Row 270 (278), bind off the remaining sts.

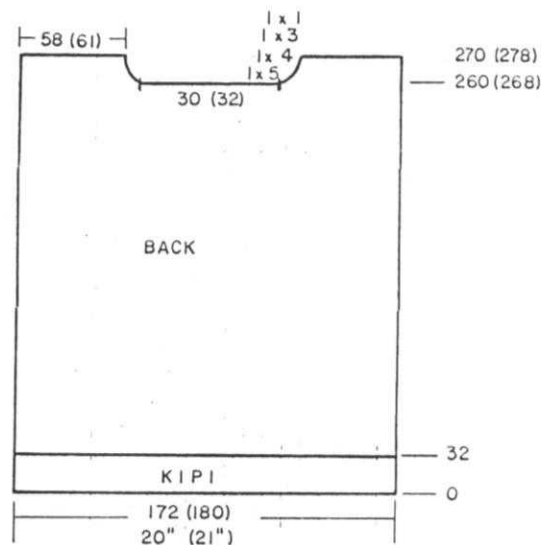

Bring the needles on the left into working position, set Pattern from LEFT TO RIGHT on MARKED ROW and turn Row Counter back to 260 (268) and complete the left side. Follow the instructions from *.

FRONT: Make 1, reverse 1.

Cast on 82 (86) sts. with color 1 and work 32 rows K1, P1 Ribbing. Transfer the ribber sts. to main machine. Work 4 rows Stockinette stitch with color 1 then continue in Pattern same as back.

After Row 170 (174) SHAPE FRONT

NECK: Decrease 1 st. every 4th row 24x (25x).

After Row 270 (278) bind off the remaining sts.

Make 2nd front section with reverse shaping.

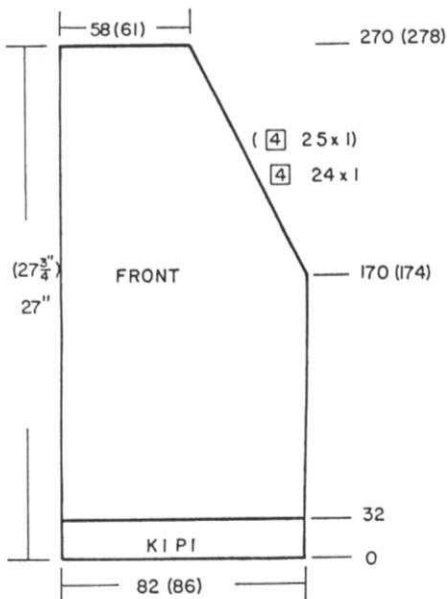

FRONT & NECK BAND

Use tight a tension as possible on BOTH BEDS. With color 1, cast on 24 sts. and work K1, P1 Ribbing. Beginning at Row 12, MAKE BUTTONHOLE by knitting 1 st. in center on both beds with a strand of contrast yarn. Leave sts. in work. Make the following buttonholes after Rows shown on the Chart in the same way (7 buttonholes in all). After Row 720 (740) about 62" (64") remove the sts. onto contrast waste yarn.

FINISHING: See General Instructions. Sew front and neck band in place. Weave the open sts. held on waste yarn (band) to finish band (see Instruction Manual). Finish buttonholes and sew buttons to other side.

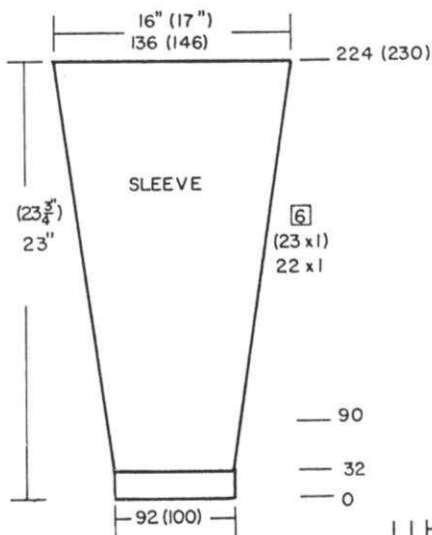

SLEEVES:

Cast on 92 (100) sts. with color 1 and work 32 Rows K1, P1 Ribbing. Transfer the ribber sts. to main machine. Knit 2 (8) rows Stockinette stitch then continue in Pattern. After Row 90, ON EACH SIDE, increase 1 st. every 6th row 22x (23x). After Row 224 (230), bind off the remaining sts.

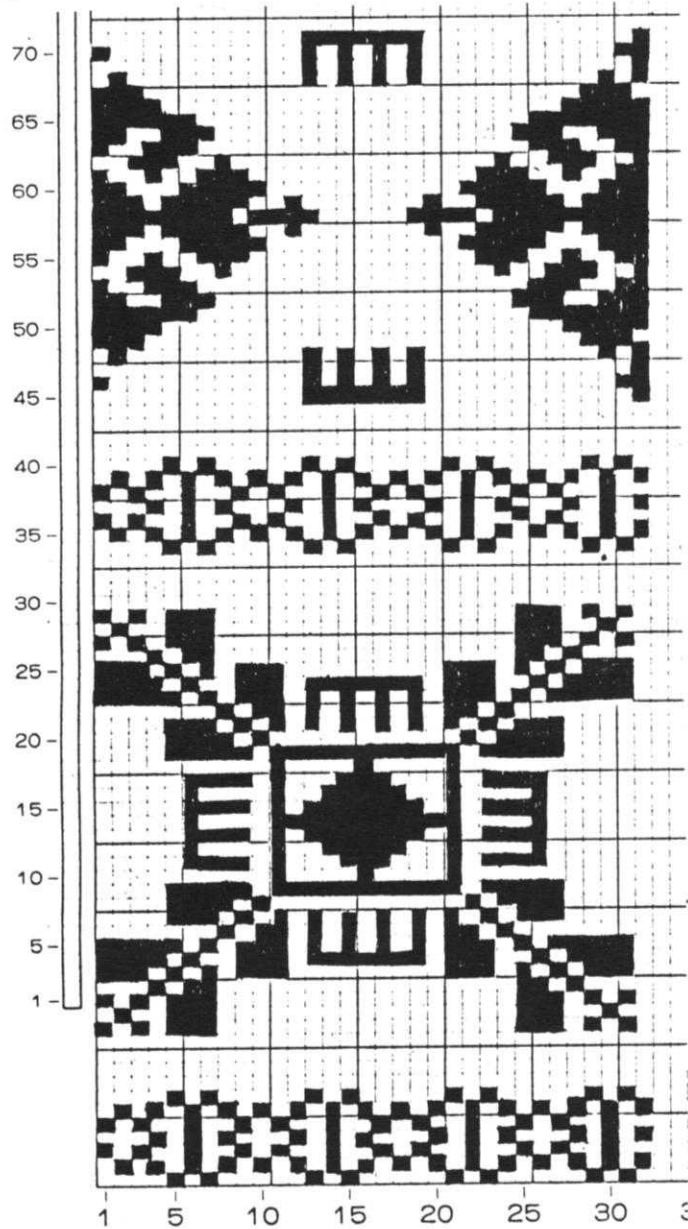
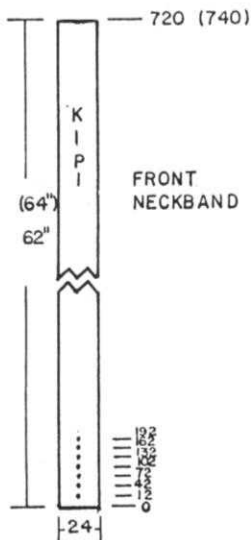

TO GO ALONG SIDE 910 PATTERN SHEET

		FEEDER A	FEEDER B
PATTERN	7 Rows	color 1	- color 2
	4 Rows	color 1	
PATTERN	31 Rows	color 1	- color 3
	4 Rows	color 1	
PATTERN	7 Rows	color 1	- color 2
	4 Rows	color 1	
PATTERN	27 Rows	color 1	- color 3
	4 Rows	color 1	

REPEAT FROM BEGINNING.



WOMAN'S PULLOVER & SKIRT

SIZES: 6/8 (10/12) [14/16]

YARN: Venetia

color 1 1 1/2 lbs. for all sizes.

color 2 8 oz. for all sizes.

TENSION: 5 - Rib. 1/1 II

GAUGE: 16 sts. 24 rows = 2" (5 cm)

Stockinette stitch with Short Rows.
Do not wrap the needles when knitting the Short Rows on the TOP but you MUST WRAP the inside needle in holding position when knitting the SKIRT.
Bands are K1, P1 Ribbing.

BACK:

Work the back the same as the front in plain Stockinette stitch using color 1. Be sure to mark each side after Row 156 (162) [168] for setting in sleeves.

FRONT:

Cast on 153 (165) [177] sts. with color 1 and work 30 rows K1, P1 Ribbing. Transfer the ribber sts. to main machine and increase 1 st. on the right side.

Knit 2 rows then begin the SHORT ROWS. Put 78 (84) [90] sts. on the LEFT SIDE into holding position. Over the remaining 76 sts. knit 4 rows then ON THE LEFT put 1 st. into holding position and again every 4th row 45x (48x) [51x]. DO NOT WRAP as the hole is part of design. AT THE SAME TIME, after Row 156 (162) [168], mark the side edge with a bit of yarn for setting in sleeve.

After Row 212 (224) [236], put the remaining 31 (34) [37] sts. into holding position.

Turn Row Counter back to 32. Leave 78 (84) [90] sts. on the RIGHT in holding position and work the LEFT SIDE same as the right side.

After Row 212 (224) [236], leave ALL BUT THE CENTER 2 sts. in holding position and work PUSH BACK SHORT ROWS with color 2. On every 4th row ON EACH SIDE, bring back 1 st. 45x (48x) [51x]. After Row 212 (224) [236], continue in Stockinette stitch over ALL NEEDLES using color 2.

After Row 258 (272) [286], ON EACH SIDE, remove 40 (42) [44] sts. onto contrast waste yarn. Over the remaining sts. ON EACH SIDE, increase 1 st. every 2nd row 5x. After Row 270 (284) [298], remove the remaining sts. onto waste yarn (or you can bind them off loosely).

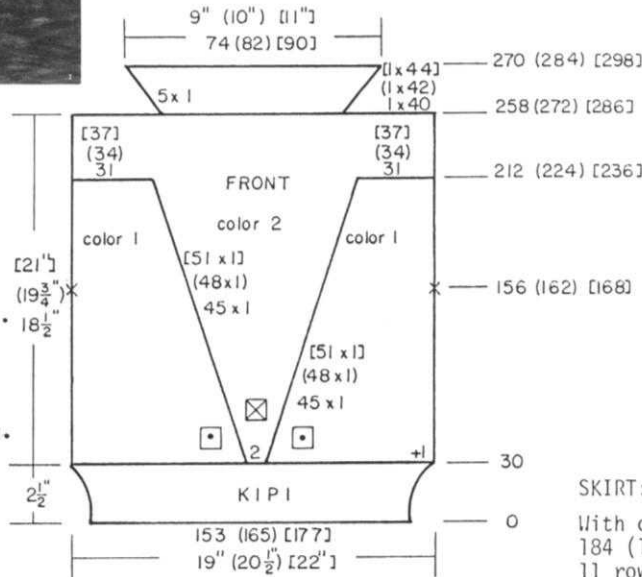

SLEEVES:

Cast on 69 (77) [85] sts. with color 1 and work 36 rows K1, P1 Ribbing. Transfer the ribber sts. to main machine and increase 1 st. on the right side.

ON EACH SIDE, increase 1 st. every 5th row 34x (35x) [36x] BUT AT THE SAME TIME, after Row 94 (98) [102], put the CENTER 2 sts. PLUS the remaining sts. on the LEFT into holding position and complete the right side first. Continue the increasing on the right only and work SHORT ROWS ON THE LEFT. ON EVERY 4th row, put into holding position 1 st. 30x (32) [34x].

After Row 214 (226) [238], put the remaining sts. into holding position. Put Row Counter back to 94 (98) [102].

Leave the 2 center sts. plus all needles on the right in holding position and complete the left side. Work the SHORT ROWS same as before and continue the increases on the left.

After Row 214 (226) [238], put all but the 2 center sts. into holding position. Work the PUSH BACK SHORT ROWS same way as for front. After Row 214 (226) [238], remove all the sts. onto contrast waste yarn or you can bind them off loosely.

FINISHING: See General Instructions. Close shoulders then set in sleeves to marked edges. Turn under facing and sew in place.

SKIRT: Color 1.

With contrast waste yarn, cast on 184 (192) [200] sts. Knit 9 to 11 rows then change to garment yarn and Counter at 0. Work Stockinette stitch with Short Rows and be sure to always wrap the inside needle in holding position to prevent a hole. Knit 10 (12) [14] rows Stockinette st. ON OPPOSITE SIDE OF CARRIAGE, put into holding position 10 sts. 1x (all sizes) then 19 (20) [21] sts. 8x. 22 sts. remain in work. ON OPPOSITE SIDE OF CARRIAGE, push back into working position 10 sts. 1x for all sizes, then 19 (20) [21] sts. 8x. Knit 6 rows for all sizes. *ON OPPOSITE SIDE OF CARRIAGE, put into holding position 102 (110) [118] sts. 1x, then 20 sts. 3x. Push back into working position 10 sts. then 20 sts. 3x. Knit 6 rows over all sts. REPEAT FROM * 3x MORE. Work the A SECTION SHORT ROWS Knit 20 (24) [28] rows over all stitches. ** Work the B SECTION SHORT ROWS. Work the A SECTION SHORT ROWS. Knit 20 (24) [28] rows over all stitches. REPEAT FROM ** 6x MORE. (7x in all) BUT ENDING WITH 10 (12) [14] rows over all stitches. Remove onto contrast waste yarn.

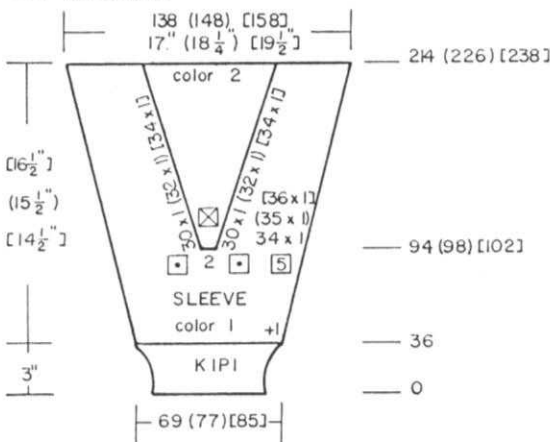

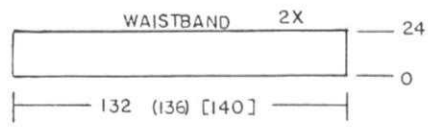
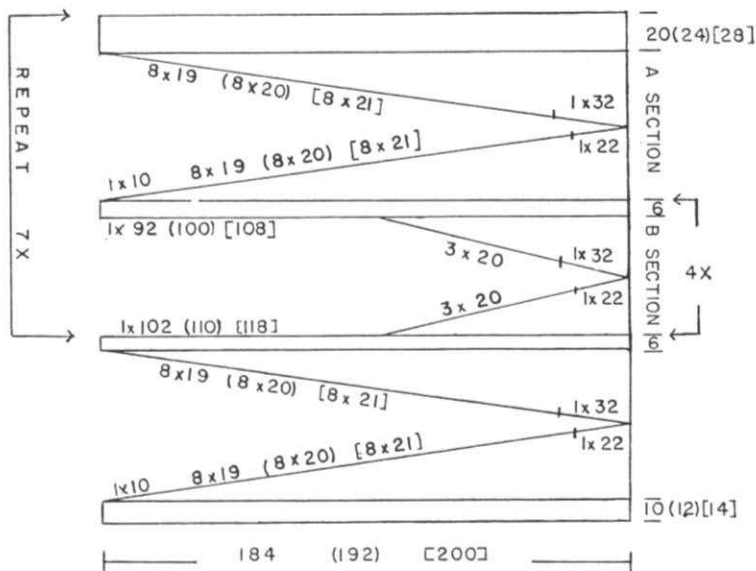

WAISTBAND: Make 2.
 With wrong side facing you, hang half the skirt waist onto 132 (136) [140] needles.
 Work 24 rows Stockinette stitch.
 Hang hem and bind off LOOSELY.

FINISHING: See General Instructions.
 SKIRT: Weave the open sts. and remove waste yarn. Pull elastic through casing at waist then close opening.
 PULLOVER: Close shoulder then set in sleeves to marked edges. Turn under facing and sew in place.

439

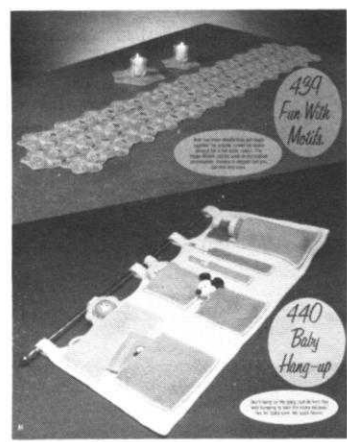

TABLE OR BUFFET RUNNER
 (Can be made into Table Cloth by knitting more Motifs).

YARN: Venetia (fine) Approx. 8 oz.
 TENSION: 3.2 (for fine Venetia)
 GAUGE: Not important.

There are 3 sizes of Punch Cards. Use the SMALL Size for Table or Buffet Runner, the larger sizes as decoration under a flower vase on small tables, etc.

PUNCHCARDS -
 SMALL = 12 sts.
 MEDIUM = 16 sts.
 LARGE = 20 sts.

You can make 6 Motifs at a time by using Crochet Cotton for Ravel Cords between each Motif then after hanging each Motif back onto the machine to bind off, cut the crochet cotton after bind off, pull it out and throw it away.

OPEN CAST ON with Crochet Cotton. 12 (16) [20] sts. Be sure you have 6 (8) [10] sts. each side of 0. Knit at least 10 rows of waste knitting. COUNTER AT 0. Change to Venetia and LEAVE A LONG STRAND OF YARN AT BEGINNING AND END OF MOTIF.

Knit 2 rows Stockinette stitch. Work Lace Pattern, knitting 2 rows between lace transfers except where Card is marked to knit 4 rows. After LAST transfer, knit 2 rows to complete Motif. COUNTER READS 144 (192) [242].

With Crochet Cotton, knit 10 rows. Continue with next Motif - Counter at 0 each time you begin a new Motif.

After making 4 to 6 Motifs, remove strip from machine by knitting 10 rows crochet cotton, then slide carriage across without cotton. For approximately 63" long runner you need 37 Motifs.

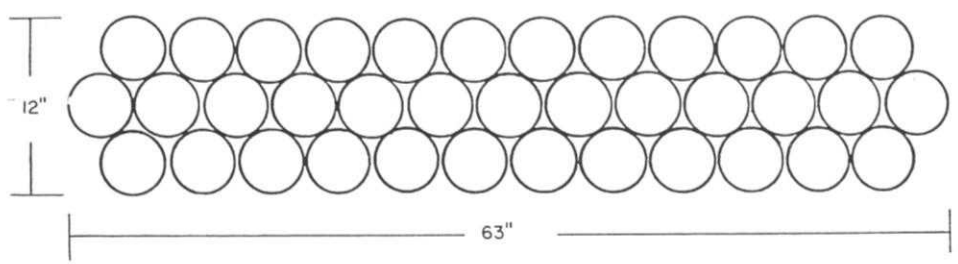
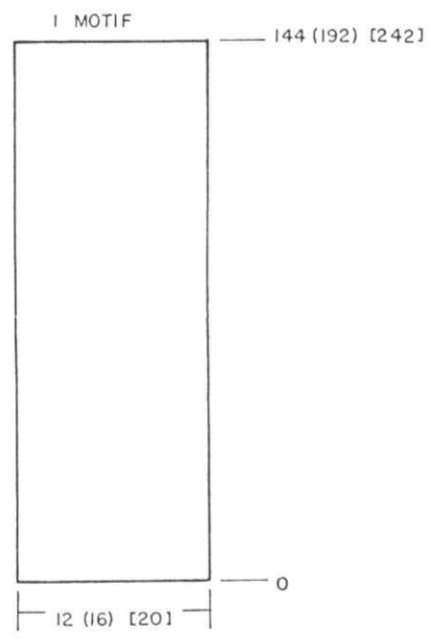
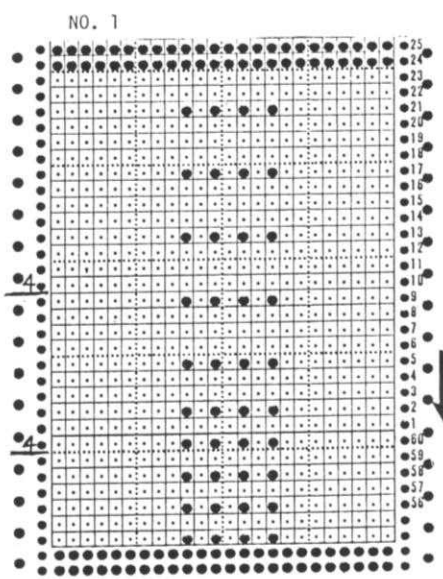

Continued

NO. 3

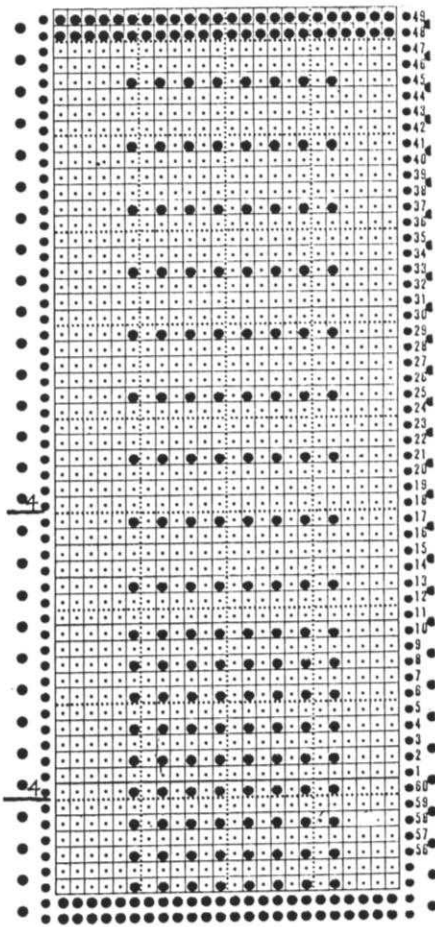

FINISHING:

With right side facing you and LONG STRAND of Yarn on the RIGHT SIDE, hang the open sts. of one end of Motif onto 12 (16) [20] needles and put the sts. BEHIND the latches.

With WRONG side facing you hang the other end of Motif onto the same needles in FRONT of the latches. (Be sure not to twist the Motif). Pull the front sts. through the back sts. With strand of yarn hanging from Motif, Knit 1 very LOOSE ROW (tension 7 or 8) from right to left then crochet bind off - or you can use the LINKER 8310 to bind off the stitches.

Cut waste knitting close to bind-off on all 4 edges then pull out the waste knitting and throw it away. REPEAT for all Motifs. Steam press circle gently. Place 3 motifs together, one point from each Motif touching. With small crochet hook, slip stitch each touching point - going into each point separately using attached yarn. End with slip stitch into first Motif point again. Pull into shape and press again. Add next row of Motifs. If you place all the Motifs on a table you will see how to attach them (See Picture).

NO. 2

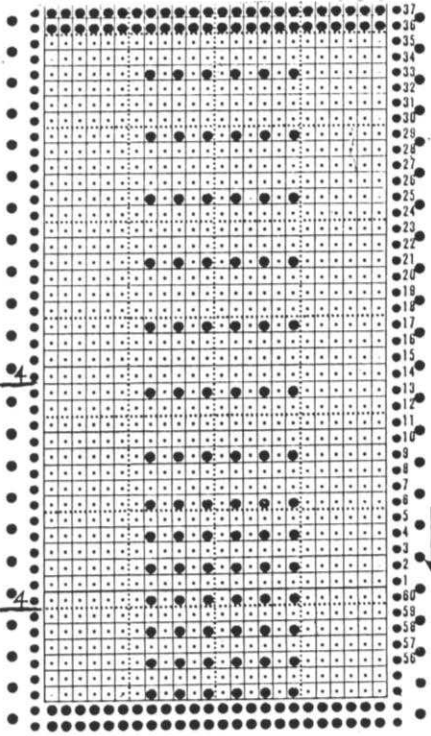

440

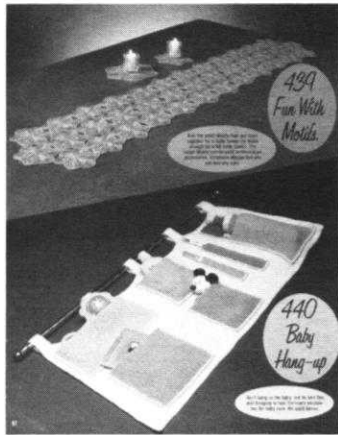

BABY HANG-UP

SIZE: 22 1/2 x 14 1/2"
 YARN: Amore
 AMOUNT: color 1 3 balls
 colors 2 to 7 - small amounts - Use Left over yarn, or you can purchase 1 ball of each color.
 TENSION: 4
 GAUGE: Not important.
 A two row Tuck Pattern.
 Punch Card.
 Purchase toys and different baby needs to put in pockets... See Picture.
 Use alternate colors to make each section. Choose your own colors.
 BACKGROUND:
 Cast on 150 sts. with color 1 and work 252 rows in Tuck Pattern. Bind off loosely.

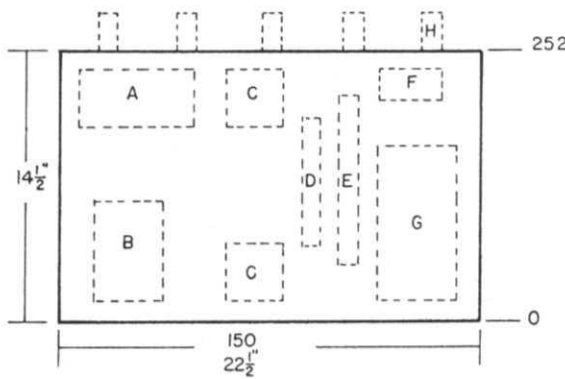
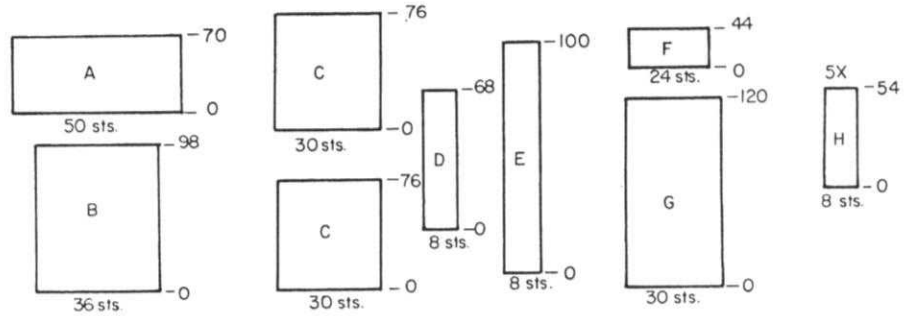

SECTION A:

Cast on 50 sts. and work 70 rows in Pattern. Bind off

Work section B, C, (make 2 of C) D, E, F, G sections in the same way following the Charts for cast on and Row Number.
 For the 5 HANGERS, cast on 8 sts. and work in Pattern to Row 54, Bind off

FINISHING: Work 1 row single crochet around each section except Hangers. Sew in place as shown. Sew the hangers across Top as shown, folding each in half first.

KnitKing News

PRACTICAL KNITTING HINTS

SPECIAL CAST ON EDGE

A beautiful finished cast on edge can be made by casting on with your latch hook tool. It is especially nice if you are using a Lace Design. The method for using this cast-on is in your Instruction Manual. For this particular edge, bring the required needles into 'E' position (holding) and latch tool cast on from LEFT TO RIGHT. Again latch tool cast on over all needles from RIGHT to LEFT and once more from LEFT TO RIGHT. Knit 1 row SLOWLY from right to left. Knit 3 more rows. Carriage is on the RIGHT. Begin any Lace Pattern.

INCREASING OR DECREASING WHEN USING THE RIBBER

1 x 1 INCREASING. - To increase, take the double eyed Ribber Transfer Needle and reach down BELOW the end stitch on the Main Machine, pick up cross thread, skip 1 needle and place onto next empty Ribber needle. For next increase, pick up cross thread below end ribber needle, skip 1 needle and place onto next empty Main Machine needle. Continue in this way, working back and forth from Main Machine to Ribber, then Ribber to Main Machine.

1 x 1 DECREASING. - To decrease, With double eyed Ribber Transfer Needle, remove end st. from Main Machine and transfer it to end Ribber needle. For the next decrease, remove end Ribber stitch and transfer it to end needle on Main Machine.

FULL NEEDLE INCREASING. - Using the Ribber Transfer Tool, work in the same way as above but DO NOT skip an empty needle and you must increase on BOTH BEDS. Pick up a stitch from row below on Main Machine and put it onto next empty needle and pick up a stitch from row below on the Ribber and place onto next empty Ribber needle.

TO DECREASE, always transfer end stitch ON EACH BED and place onto inner needle then put empty needles to 'A' (out of work) position.

IMPORTANT INSTRUCTIONS WHEN USING THE ELECTRIC CARRIAGES - KG 88 or KG 89

STOCKINETTE STITCH: - Normally, when knitting on the machine the PURL SIDE ALWAYS FACES YOU. However, when using the Electric Carriages - for the KH 910 or the KH 891 WITHOUT a Mylar Sheet or a Punch Card, the KNIT SIDE will ALWAYS FACE YOU.

When you want the PURL SIDE TO FACE YOU (for 910 machine only) read the BLANK SPACES (only 1 spot) on the Mylar sheet. See Pattern No. 426 in this issue. You can also have the PURL SIDE facing you without using the Mylar sheet. The 910 machine must be turned ON then PUSH UP THE NO. 6 BUTTON.

FOR THE KH 891, Set the Punch Card on any BLANK LINE (NO HOLES PUNCHED) then set the CARD ON STOP and leave it there.

K1, P1 RIBBING on the KH 910: - When you want K1, P1 Ribbing, MAKE ONLY 1 DOT on the Mylar Sheet (any place) then READ THE DOT PLUS A BLANK SPACE.

YARN KITS FOR GARMENTS IN THIS ISSUE

Most of the garments in this issue of KNITKING MAGAZINE were knitted with yarns from our YARN CATALOGUE which illustrates the full range of colors available and includes actual yarn samples. If you do not have our Catalogue, please send \$3.00 and we will mail you one immediately and you will be able to choose your own colors.

VENETIA, our best selling yarn is not shown in the Catalogue. We have 20 colors available and if you tell us the color or colors you want, we will select a color as close as possible to your selection.

No. 421 - Yarn: Amore
SIZES: 40/42 (44/46)
Price: \$14.34 \$16.73
Shipping: 1.85 1.85

No. 422 - Yarn: Amore (Medium) [Large]
Price: \$11.95 \$14.34
Shipping: 1.85 1.85

No. 423 - Yarn: Venetia
SIZES: 6/8 (10/12) [14/16]
Price: \$51.60 \$51.60 \$51.60
Shipping: 2.50 2.50 2.50

No. 424 - Yarn: Venetia
SIZES: 6/8 (10/12) [14/16]
Price: \$46.44 \$56.76 \$56.76
Shipping: 2.50 2.50 2.50

No. 425 - Yarn: Cordella
SIZES: 2/4 (6/8) [10/12]
Price: \$11.72 \$13.71 \$13.71
Shipping: 1.85 1.85 1.85

No. 426 - Yarn: Alanda
SIZES: 6/8 (10/12) [14/16]
Price: \$11.20 \$12.80 \$14.40
Shipping: 1.85 1.85 1.85

No. 427 - Yarn: Alpacana
SIZES: 34/36 (38/40) [42/44]
Price: \$18.20 \$20.80 \$20.80
Shipping: 1.85 1.85 1.85

No. 428 - Yarn: Venetia, Angora, Multi-Show
SIZES: Small (Medium) [Large]
Price: \$70.78 \$82.39 \$89.18
Shipping: 3.50 3.50 3.50

No. 429 - Yarn: Venetia, Angora, Capriccio
SIZES: Medium
Price: \$45.29
Shipping: 2.50

No. 430 - Yarn: Multi-Show, Venetia, Angora
SIZES: Small (Medium) [Large]
Price: \$43.44 \$43.44 \$43.44
Shipping: 2.50 2.50 2.50

No. 431 - Yarn: Venetia & Multi-Show
SIZES: 6/8 (10/12) [14/16]
Price: \$72.25 \$75.20 \$75.20
Shipping: 3.50 3.50 3.50

No. 432 - Yarn: Venetia & Wool Tweed
SIZES: 10/12 (14/16)
Price: \$61.08 \$61.08
Shipping: 3.50 3.50

No. 433 - Yarn: Cordella
SIZES: 6/8
Price: \$5.97
Shipping: 1.85

No. 434 - Yarn: Venetia
SIZES: 6/8 (10/12) [14/16]
Price: \$51.60 \$51.60 \$51.60
Shipping: 2.50 2.50 2.50

No. 435 - Yarn: Amore
SIZES: 2 (4) [6] 8
Price: \$9.56 \$9.56 \$11.95 \$11.95
Shipping: 1.85 1.85 1.85 1.85

No. 436 - Yarn: Multi-Show & Angora
SIZES: Small (Medium) [Large]
Price: \$35.00 \$37.95 \$40.90
Shipping: 2.50 2.50 2.50

No. 437 - Yarn: Beatrice
SIZES: 38/40 (42/44)
Price: \$39.90 (39.90)
Shipping: 1.85 1.85

No. 438 - Yarn: Venetia
SIZES: 6/8 (10/12) [14/16]
Price: 41.28 \$41.28 \$51.60
Shipping: 2.50 2.50 3.50

No. 439 - Yarn: Venetia
SIZE: Approximately 63" x 12"
Price: \$10.32
Shipping: 1.85

No. 440 - Yarn: Amore
SIZE: 22 1/2" x 14 1/2"
Price: \$7.17
Shipping: 1.85

Essentials

Order from your local Dealer or direct from
KNITKING—1128 Crenshaw Blvd.,
Los Angeles, California 90019

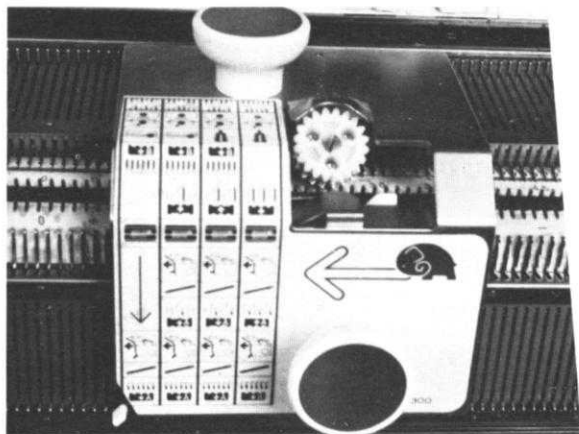

For fast and accurate transfer of stitches from Ribber to Knitter, the Automatic Transfer Carriage is ESSENTIAL.

Model 8300 is for Ribbers KR 900, KR 880, KR 850 and KR 830 and machine Models KR 830 through KH 910.

The PM 10 Automatic Punch Card puncher is essential for speedy punching of all your punch card designs. It's O.K. for all KNITKING, Singer, Studio and Toyota punch card machines except the Singer/Studio F-370 machine which uses the PM 70 Automatic Puncher.

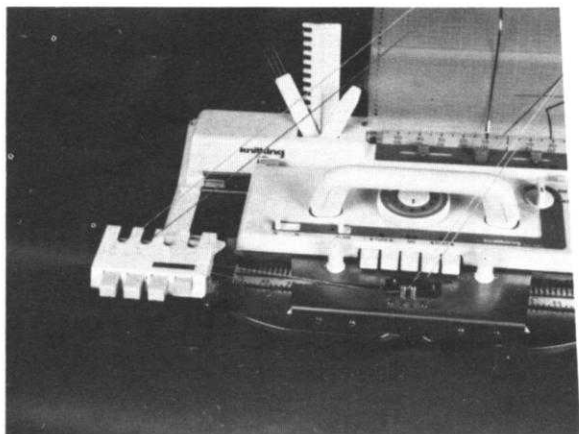
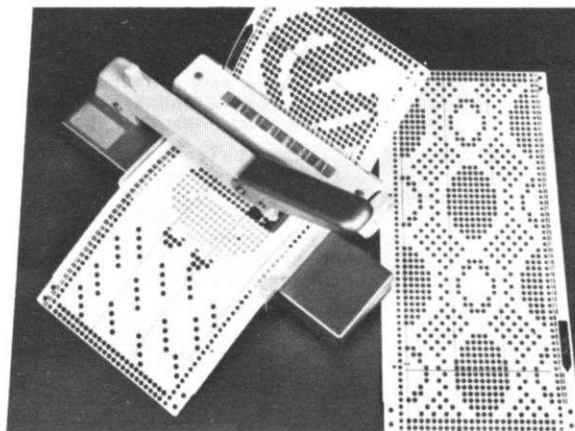

The KHC 820 Color Changer is essential for automatic changing of colors when knitting on KNITKING machine Models KH 820 through KH 910.

The KRC 830 Color Changer is essential for automatic color changing and the knitting of four color designs when using a Knitter and Ribber combination. It operates on Models KH 820 through KH 910 with Ribbing Attachment.

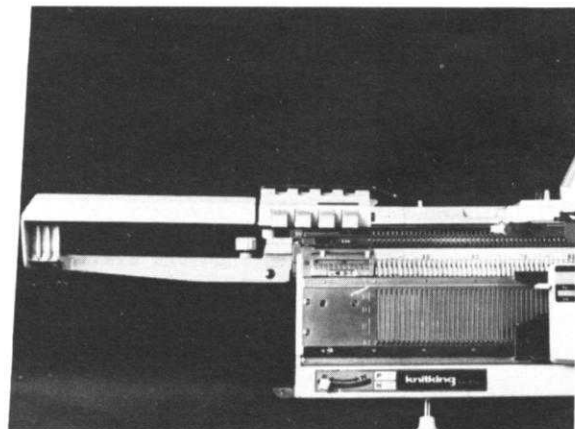

knitking KNITTING COMPUTER

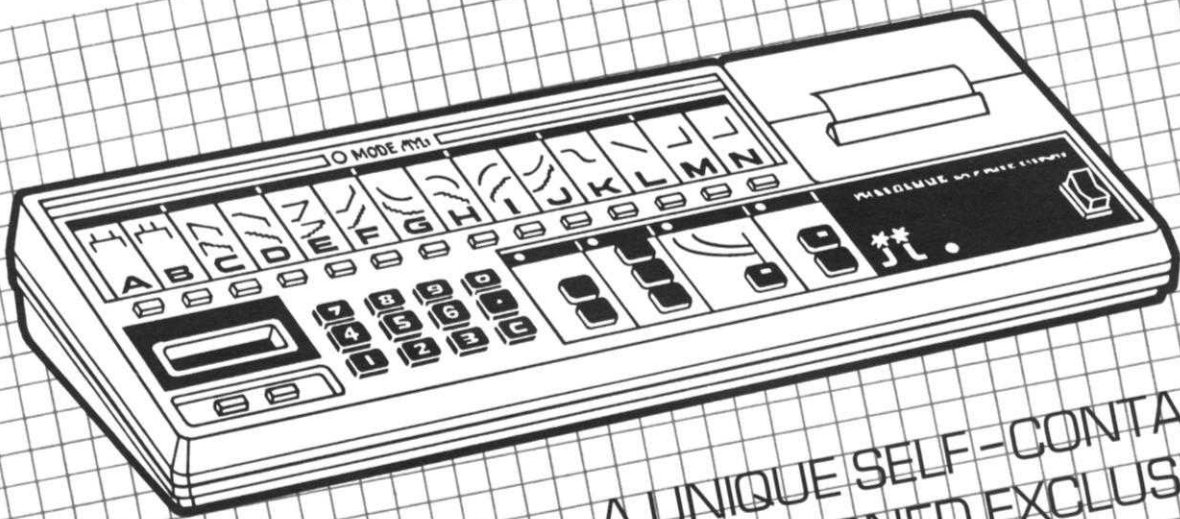

A UNIQUE SELF-CONTAINED
COMPUTER DESIGNED EXCLUSIVELY
FOR HAND AND MACHINE KNITTERS.

Every shape of garment sections, necklines, armholes, etc., is represented by a 'MODE' button. Push a Mode Button, program in your Stitch and Row Gauge, follow it with the Width and Length of the garment section, then watch the printer print out complete knitting instructions.

The Computing of knitting patterns can be done with standard computers plus expensive software, and you can easily spend thousands of dollars to obtain the same results as produced by the KNITTING Knitting Computer at a fraction of the price.

The KNITTING Knitting Computer operates with built in re-chargeable Nickel Cadmium Batteries. A charger is standard equipment as is a detailed Instruction Manual and some spare rolls of print out tape.

Price: \$499.00 (California residents add Sales Tax)
Order from your local dealer or direct from

**KNITTING — 1128 Crenshaw Blvd.,
Los Angeles, CA 90019**



NEW, DEMONSTRATORS AND TRADED MACHINES AT GIVE AWAY PRICES...

Nobody can beat our prices, so if you want a second machine, place your order as fast as possible... Maybe you have a friend who cannot afford a brand new machine... If so, please tell her about our low, low prices... and if you want a machine not listed below, let us know... We have too may to list them all.

ALL PRICES F.O.B. LOS ANGELES - SHIPMENT VIA UPS

		<u>CONDITION</u>	<u>LIST PRICE</u>	<u>SALE PRICE</u>
<u>KNITKING -</u>				
KH 910	COMPUKNIT ELECTRONIC W/Lacemaker OK for use with KG 88 Garter Carriage (Demo - New Machine Guarantee)	Like New	\$949.95	\$699.00
KH 891	Punch Card Knitter W/built in Knitleader and Lacemaker	Like New	599.95	499.95
KH 881	Punch Card Knitter W/built in Knitleader and Lacemaker	Excellent	599.95	399.95
KH 840	Punch Card Knitter W/Lacemaker	Excellent	569.95	299.95
KH 830	Punch Card Knitter W/Lacemaker	Very Good	499.95	249.95
KH 820	Punch Card Knitter W/Lacemaker	Very Good		199.95
KH 230	BULKY (Demo) New machine Guarantee	Like New	379.95	249.95
KH 120	258 needle Knitter - Push Button Pattern Selection and Lacemaker	Excellent	429.95	195.00
KH 341	Folding Knitter W/built in Knitleader and Carrying Case	Like New	249.95	125.00
CN 9N	Jumbo Knitter	Very Good	299.95	95.00
KR 900	RIBBER- (Demo) For 910, 891, 881, 860, 840, 830	Like New	299.95	199.95
KR 830	RIBBER -	Excellent	289.95	149.00
KR 230	Bulky Ribber (Demo)	Like New	299.95	195.00
<u>SINGER</u>				
SK 500	Computerized Electronic	Excellent	950.00	299.00
SK 360	Punch Card Knitter	Excellent	529.95	399.00
MOD 150	Chunky - (Demo)	Like New	337.95	229.00
SRP 50	Ribber - Fits SK 560, 500, 360, 328	Excellent	279.95	195.00
<u>GENIE</u>				
KH 710	Push Button Pattern Selection W/Lacemaker	Like New	289.50	195.00
KR 710	Ribber (Demo)	Like New	269.50	180.00
S 120	Jumbo Genie (Demo)	Like New	279.95	150.00
SR 120	Jumbo Genie Ribber (Demo)	Like New	279.95	130.00
<u>BROTHER</u>				
KH 910	Electronic W/Lacemaker OK for use with KG 88 Garter Carriage	New	949.95	649.00
KH 840	Punch Card Knitter W/Lacemaker	Very Good	569.95	299.95
KH 820	Punch Card Knitter W/Lacemaker	Very Good		199.95
KH 551	Push Button Pattern Selection	Very Good		95.00
<u>STUDIO</u>				
SK 312	Punch Card Knitter	Very Good	349.95	125.00
SK 322	Punch Card Knitter	Very Good	399.95	175.00
SK 303	Knitter and Ribber	Very Good		150.00
SK 101	Knitter and Ribber	Very Good		99.50
<u>TOYOTA</u>				
KS 727	Punch Card Knitter	Excellent		125.00
<u>JUKI</u>				
2400	Punch Card Knitter	Excellent		150.00
<u>PASSAP - Duomatic 80 Complete with Stand - Deco</u>				
	Sold for	Like New	1400.00	795.00
<u>KNITKING LINKERS (Demo)-</u>				
BABY LOCK - 605	- 4 thread Cut/Sew/Overlock	Excellent	429.00	195.00
	606 - Blindstitch (Demo)	Like New	599.00	249.00
TRIMLOCK - 524	- 4 thread Cut/Sew/Overlock (Demo)	Like New	449.00	249.00
	523 - Three thread Cut/Over (Demo)	Like New	449.00	195.00



429
*Fashion
Importance*

Mixing yarns is a designer's joy and the results are spectacular... This Pullover is knitted sideways on the machine with a blend of textures. Use Venetia, Angora and Capriccio. Size Medium.

437
Colorful!

Bring color into his life with a great Norwegian designed Cardigan. Knit it with Beatrice on any Electronic machine. Sizes 38 to 44.

421 & 422

Fly
South...

Comfortably cool, attractive to look at
and so easy to care for... Knit this
pullover for him and for her in a
zig-zag eyelet design and be sure to
use our Amore yarn. Sizes 40 to 46 for
him, Medium to Large for her.

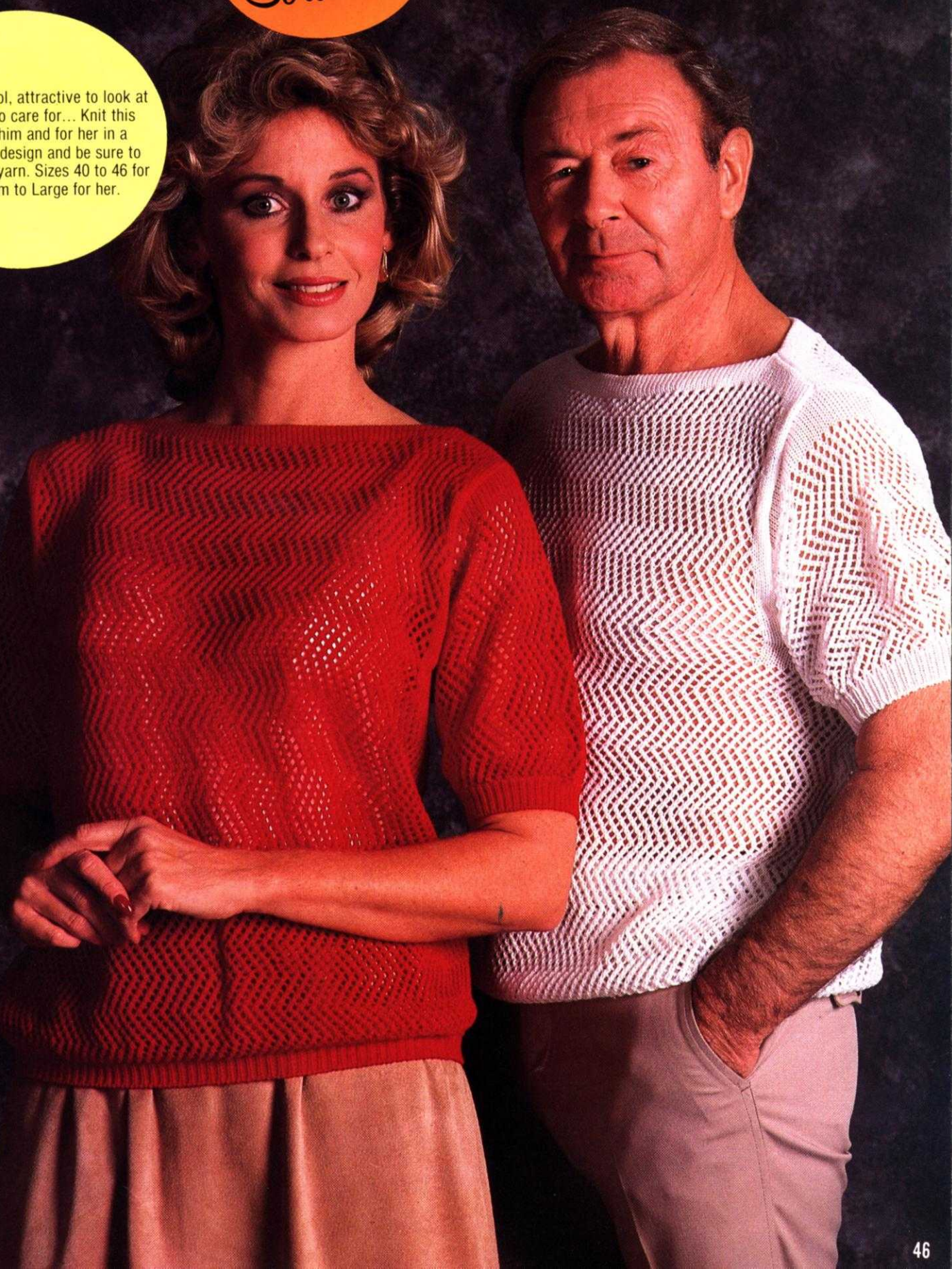

KNITKING KH 891 WITH KG 89 ELECTRIC CARRIAGE

Feed in a pattern stitch card. Set the row counter to a specific number of rows, then push the start button and you can leave to watch T.V. or cook the dinner, read a book, etc., while your knitter knits merrily along. When it has knitted the preset number of rows, it will switch itself off. If it runs out of yarn, it will switch itself off. The KG 89 Electric Carriage will knit an unlimited variety of fancy Garter Stitch designs in addition to standard ribs.

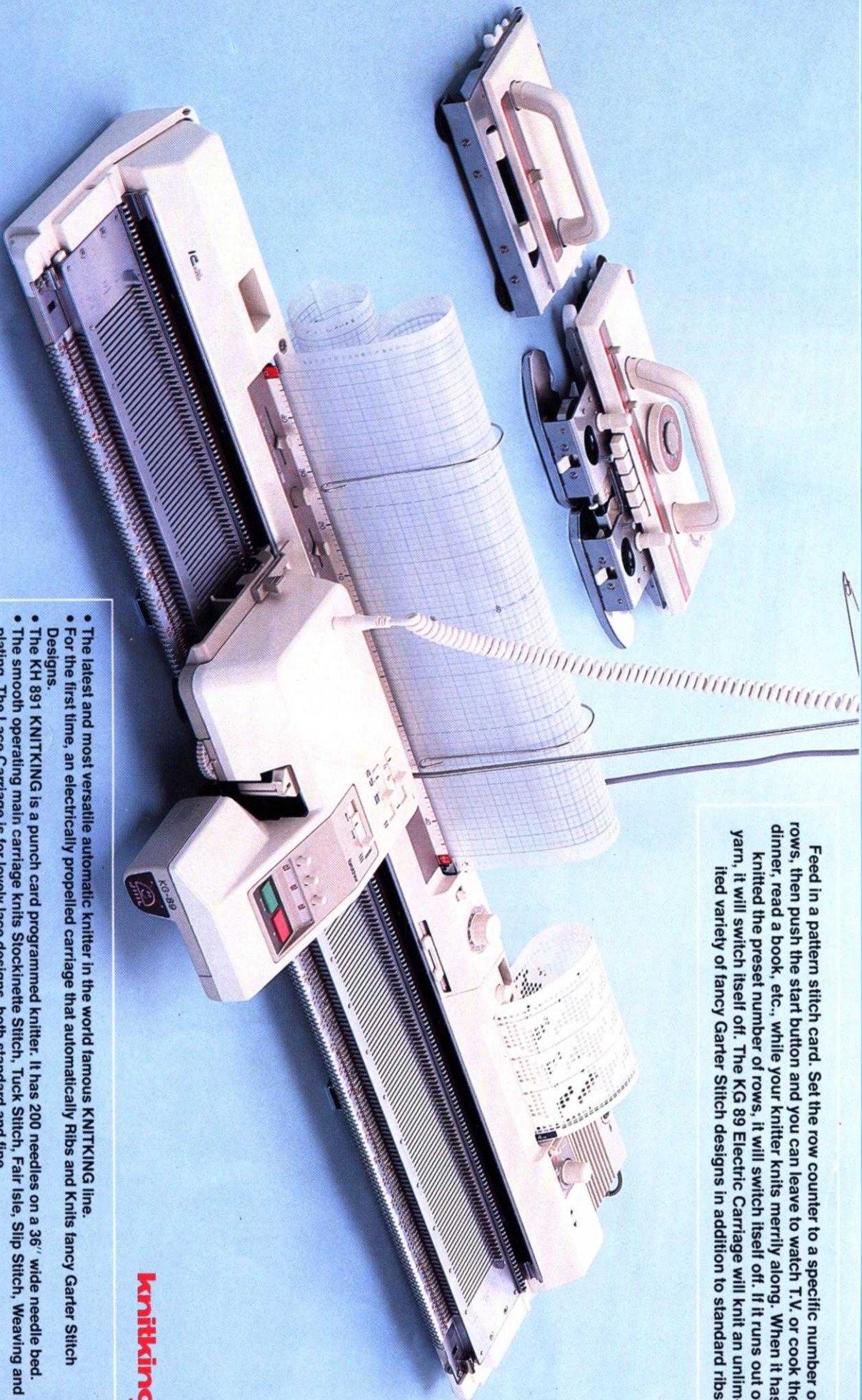

knitking

- The latest and most versatile automatic knitter in the world famous KNITKING line.
- For the first time, an electrically propelled carriage that automatically Ribs and Knits fancy Garter Stitch Designs.
- The KH 891 KNITKING is a punch card programmed knitter. It has 200 needles on a 36" wide needle bed.
- The smooth operating main carriage knits Stockinette Stitch, Tuck Stitch, Fair Isle, Slip Stitch, Weaving and plating. The Lace Carriage is for lovely lace designs, both standard and fine.
- 20 Pre-Punched Pattern Cards for all types of pattern knitting are included with every machine. The built-in Knitleader Charting accessory tells you on a row by row basis when to increase and when to decrease. Simplifies the knitting of garments to accurate size.
- A complete kit of Tools, spare needles, cabling tools, lubricating oil and two, step by step Instruction Manuals with over 400 illustrations are included and there is a one year warranty on parts and service.

Order from your local dealer or direct from **KNITKING** — 1128 Crenshaw Blvd.
Los Angeles, CA 90019

A man with short, graying hair is looking directly at the camera. He is wearing a light-colored, textured knit sweater with a ribbed crew neck and cuffs. Underneath, a plaid shirt with a white, black, and blue pattern is visible. He is also wearing light-colored, possibly khaki, trousers. The background is dark and textured.

427
*Sportsman's
Show Off*

A special Textured knit can be made on the KH 891 or 881 with an Electric Carriage. A 24 stitch Punch Card Design for the two main sections. The bands are Garter Stitch. Sizes 34 to 44, the yarn Alpacana.



435
Pretty...

Any girl will adore a bright new dress. Knit her this one with a lace bodice and full skirt. Do use our easy to care for Amore. Sizes 6 to 8.

433
*Knitting
Pretty*

She'll love a new lace Cardigan made in her favorite color. Easy to knit and easy to care for. Cordella is the yarn. Sizes 6/8.



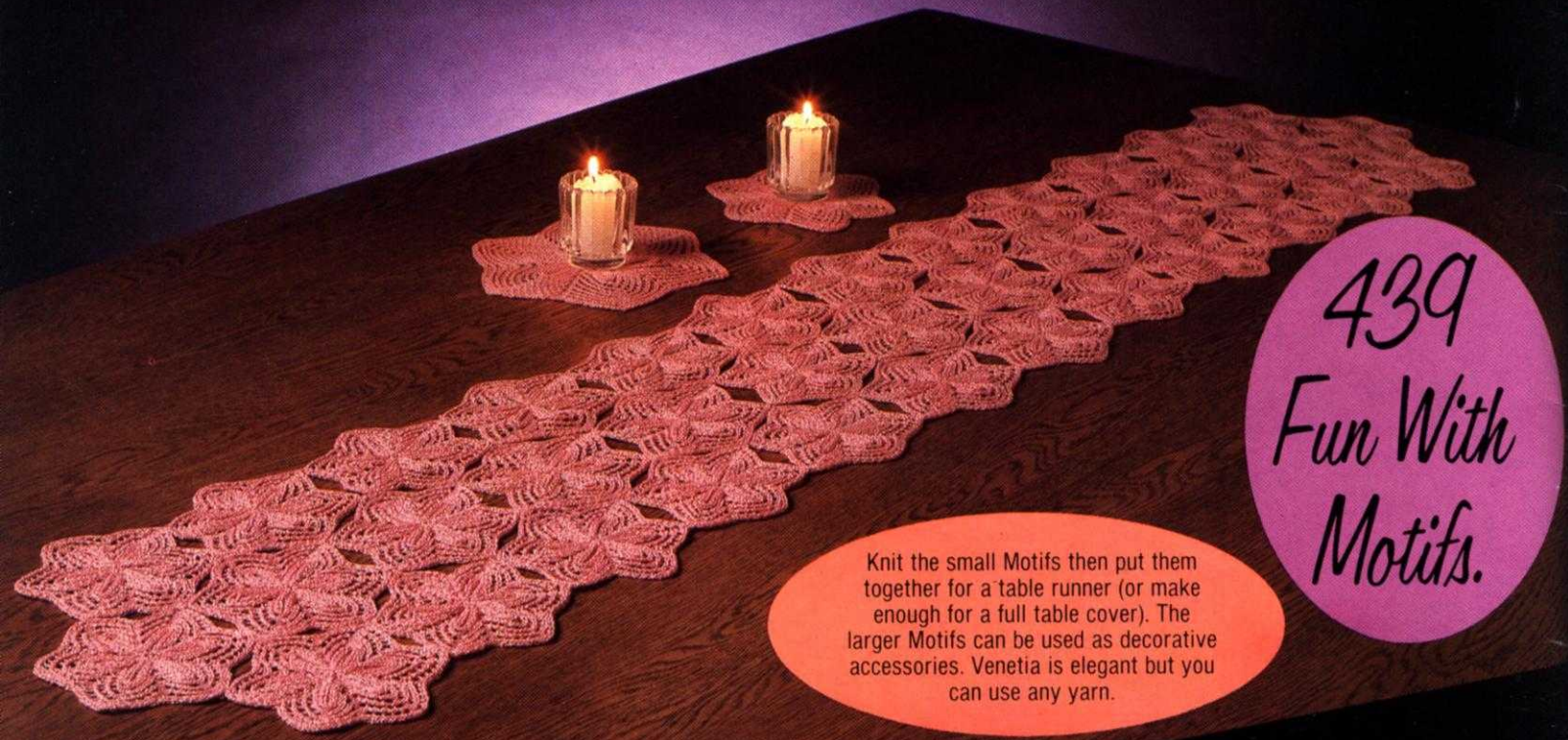

439
Fun With
Motifs.

Knit the small Motifs then put them together for a table runner (or make enough for a full table cover). The larger Motifs can be used as decorative accessories. Venetia is elegant but you can use any yarn.



440
Baby
Hang-up

Don't hang up the baby, but do knit this wall hanging to hold the many necessities for baby care. We used Amore.

425

Handsome...

He'll smile his best if you knit your boy this really super 'V' neck Pullover. Program the Fair Isle Designs on any Electronic machine or you can knit it on a Punch Card machine by choosing a 24 stitch design. Sizes 2 to 12. Cordella is the yarn.



JUMBO GENIE

TOP QUALITY and the lowest price BULKY KNITTER available anywhere. 2 Models, one with 120 needles.

The other, the Super Jumbo Genie, with 140 needles, is the widest BULKY made.



The JUMBO GENIE RIBBING ATTACHMENT (120 needles) fits both models.

JUMBO GENIE is the ideal machine for 4-ply Worsted Weight yarns...It knits Sport Weight yarn, Mohair, Angora, Boucle, Acrylic, etc. You can mix and blend yarns as you knit.

An extra Carriage for INTARSIA knitting is NOT required. INTARSIA (Picture knitting) capability is built into the standard Carriage.

Hardened Steel (not plastic) needle bed insures durability and smooth operation...The needle spacing is 8 mm.

Comes complete with twin overhead yarn feeders that adjust to various thicknesses, a Row Counter and complete kit of tools plus easy to follow Instruction Manual.

JUMBO GENIE

Illustrated is the JUMBO GENIE 120 knitting machine and JUMBO GENIE Ribbing attachment, a combination that allows the knitting of hundreds of fancy rib designs, all the standard ribs plus tubular knitting. There is a total of 240 needles allowing you to make rib knits with standard weight yarns over the 240 needles as well as Bulky yarns over 120 needles.

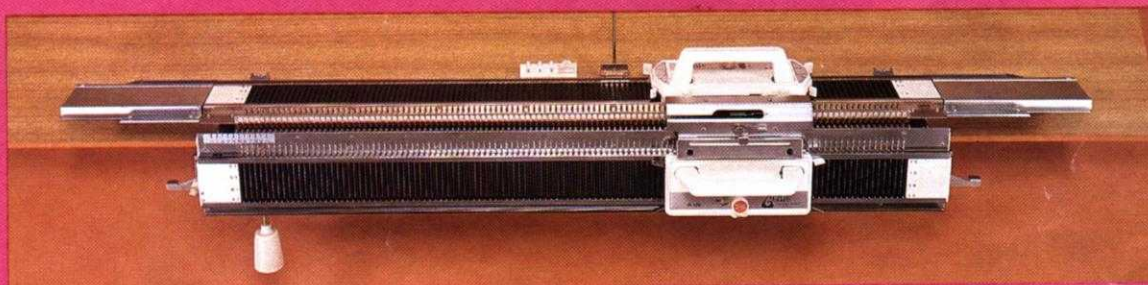
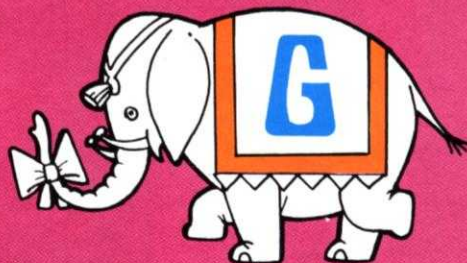

SUPER JUMBO GENIE

The photo shows the SUPER JUMBO GENIE 140 needle knitter with a coordinated JUMBO GENIE 120 Ribber attached. The combination permits the knitting of all the standard ribs, 1 x 1, 2 x 2, 1 x 3, etc.-etc. plus tubular knitting using a total of 240 needles. Racking (for zig-zag rib designs) is over 10 stitches.

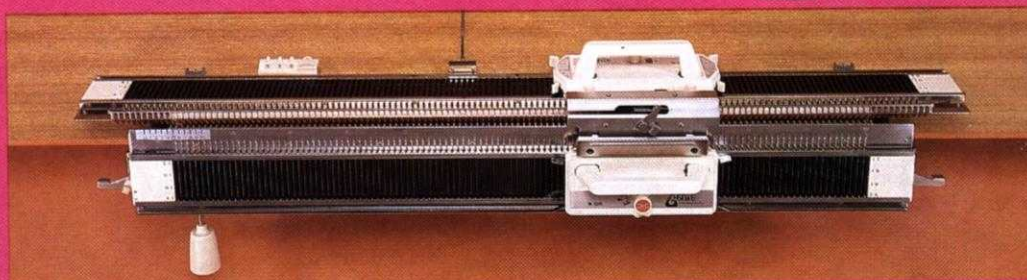
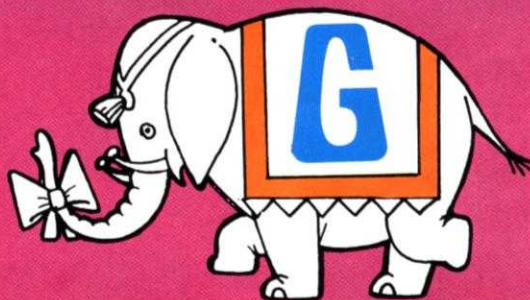

Genie

Order from your local Dealer or direct from **KNITTING**—1128 Crenshaw Blvd.,
Los Angeles, California 90019

COMPUKNIT KH 910

'The world's finest knitting machine'

- Incredibly versatile... Anything you can trace or draw is automatically reproduced in your knitting in the colors and yarns of your choice.
- Simple to program and easy to operate, the COMPUKNIT KH 910 is the 'State of the Art' in home knitting machines. It is the only knitter made that has a memory unit to retain your program if you suffer a power outage or wish to move your knitter from one place to another.
- The maximum width of motif or pattern design possible on any punch card machine is 30 stitches (the standard is 24). The COMPUKNIT has no limit. It is possible to knit a single picture or lace design over the full width (200) needles of the needle bed. It will, in fact, do everything that's possible on a punch card machine and much much more.
- If you already own a knitting machine, you must consider trading up to a fantastic COMPUKNIT 910. If you have never owned a knitter before, start at the top and save money and save all the intermediate steps.



Order from your local Dealer or direct from
VISA and MASTERCARD accepted

KNITTING

1128 Crenshaw Blvd.
Los Angeles, CA 90019
Telephone: (213) 938-2077