

VOL. 19 # 4

knitking

magazine

Norma

❏ A Garden
of Roses!
Knit Our
Flattering
Flowered
Tunic for a
Bouquet of
Compliments.



❏ 469
Stripes
Are
Right...

Vertical stripes on the bodice of this brand new and fashionable Pullover are accented with wide ribbing and horizontal stripes. The horizontal stripes are repeated on the sleeves. It is easy to knit with our Cordella yarn in sizes 8 to 14.



463
Sheer
Elegance...

The KH 260 Punch Card Bulky scores a big hit with a Thread Lace Design for a beautiful Pullover. It is absolutely gorgeous when knitted with Alanda and Mami Rex. Sizes 6 to 16.





Table of Contents



Editorial

VOLUME 19 NUMBER 4 PAGE NO.

461 - Womans Top & Skirt.....	13
462 - Womans Sleeveless Top.....	14
463 - Womans Thread Lace Top.....	16
464 - Womans Blouse & Tunic.....	17
465 - Mans Pullover.....	20
466 - Womans Flower Tunic.....	21
467 - Womans Jacket & Skirt.....	23
468 - Womans Pullover.....	25
469 - Womans Striped Pullover.....	26
470 - Mans Pullover.....	27
471 - Mans Sleeveless Pullover.....	28
472 - Womans Pullover.....	29
473 - Girls Pullover.....	30
474 - Womans Fairisle Pullover.....	31
475 - Womans Sleeveless Pullover.....	33
476 - Womans Large Size Dress.....	35
477 - Katy's Cousin Klara.....	37
479 - Baby Romper.....	39
480 - Baby Blanket & Pillow Cover.....	40
Knitking News.....	41

Goodness knows how old the phrase is - we all must hear it hundreds of times during our lifetimes - yet modern technology, travels into outer space, man made efficiently functioning space satellites plus the incredible computer skills that go into the launching and controlling of them - all these things and more would tend to contradict the claim that "there is nothing new under the sun". Fashion and style are, however, truly repetitious and do lend credibility to the phrase.

As we prepare for our twentieth volume of KNITKING MAGAZINE, we look back on our very first magazine (Sept-Oct 1964) and must say that were we to produce the identical garments today and photograph them on modern models they would be just as fashionable and stylish as they were then.

Skirt lengths get shorter - then they get longer - lapels get wider - then they get narrower - sleeves blouse out - then they fit the figure - the sloppy fit is in - then it's out. All these things go in cycles to conform to what is loosely called FASHION. We are now experiencing a resurgence of the traditional Scottish pattern stitch knitting called Paisley in womens knits and age old Norwegian designs in mens knits. The application of the techniques is different and modern knitting machines certainly make the knitting of such intricate designs easier and faster. It would be difficult to improve upon the beauty of Paisley anyway or upon the robust Norwegian pattern stitches that seem to use the infinite natural designs of snowflakes as their models. These things are certainly not new, but are, in fact, classic and modern at the same time.

We at KNITKING are pleased to observe that thinking in what constitutes fashion is rapidly becoming individualized. People are deciding for themselves just what is right for them as individuals, what colors suit them best and what shape of garment is best for their own physique. There was a time when KNITKING MAGAZINE readers ordering kits for the garments in the magazine insisted only on the colors used for the original garments. We are now seeing a tendency to vary these colors - buyers are selecting the colors they know suit them best. We applaud the trend and encourage its development.

KNITKING MAGAZINE is 21 years old with this issue. There was a time when we worked with a German company in co-producing magazines, but the arrangement was not too satisfactory and we eventually decided to publish our own exclusive magazine. Sometime, long ago, lapses in publication dates created the problem that now numbers our next volume the twentieth. We undoubtedly are the oldest (in terms of years of publication) of any specialized knitting machine magazine in the world and we will continue to endeavor to produce only the best for our readers, many of whom have been subscribers since our very first issue in September of 1964. We thank you all and say 'Please keep looking forward to receiving our next issue'!



Cover



466 Roses... Roses...

Combine three different yarns for this spectacular Tunic and program the isolated designs on your KH 910 (or any Electronic) machine. It really is easier than you think and flattering to any figure. Sizes 10 to 20 and the yarns are Venetia, Beatrice and Amore.

The photos in this issue were taken on location in an estate home at Manhattan Village, Manhattan Beach, California.

Publisher: KNITKING CORPORATION, 1128 Crenshaw Blvd., Los Angeles, Calif. 90019. Telephone: (213) 938-2079. Published quarterly. Subscriptions: USA - \$18.00 annually, single copies \$5.00; \$21.00 all other countries. The entire contents of KNITKING MAGAZINE are copyright and must not be reproduced in any shape or form without the express permission, in writing, of the publisher.

© COPYRIGHT 1985 by KNITKING CORPORATION.



 475
Unique...

Intarsia or Short Row knitting for a lively Pullover, not difficult to make and the end results are worth the effort. Full needle ribbing for the bands. We used a new 100% Swiss Cotton called Marisa. It's in sizes 4 to 14.



464
Casual
Duo...

Two for one...The Striped Pullover can be worn alone or slip the Tunic over it for a layered look. You can wear the Tunic over a different pullover or dress for a change of pace. Knit it with Venetia in sizes 6 to 16.





476 Dramatic

The specially designed dress for a full figure is truly elegant and the easy fit is so flattering, you will certainly want to make several. It is knitted on the KH 910 (or any electronic machine). See our Yarn Kits offer on Practical Knitting Hints page for information on obtaining full size copies of the designs. Sizes 42/44. Venetia with Roma yarn.



❖ 474
Sensational...

Splash colorful Fair Isle Designs on the front of a beautiful Pullover. Program it all on your KH 910 (or any Electronic machine) and watch heads turn when you wear it. Knit it with our newest yarn Roma in sizes 10 to 16.



❁ 461
Sophisticate...

Excellent for travel or out on the town, a two-piece Dress is picture pretty. Intarsia knitting for the front section of Top with Skirt in Stockinette stitch. Knit it in sizes 6 to 16 with Venetia, our most popular yarn.





467
Classical
Suiting...

A two-piece Suit has a Chanel type Jacket in a Fair Isle Design. The Skirt is Stockinette stitch with side slit for easy motion. Tack a perky bow at neckline of Jacket. Knit it in sizes 6 to 16 with Venetia.

 472

Dramatic Elegance

Cris-Cross the ribbed bands on the front of the new Designers Pullover. The bands are knitted separately then sewn in place. It's made on the KH 230 (or any Bulky) with Ribber. It will fit sizes 8 to 14. Alanda is the yarn.



General Instructions

THE PRINTED INSTRUCTIONS

Follow the printed instructions or use them in combination with the Charts. Where there is any question in the instructions, you have the Charts to show you how the section will look.

Be sure to READ AHEAD so that you KNOW what to do for the size you are knitting. In the shapings, where the number of stitches are the same but the number of times different, you might find shapings like this... 3 sts. 1 x (2x) [3x]—so that for the first size you will bind off 3 sts. 1x, 2nd size 3 sts. 2x, 3rd size 3 sts. 3x. Sometimes the ROWS will be different for each size—so you must watch out for different row numbers.

Shoulder and neck shapings for the back section of a garment usually are shaped at the same time—so ALWAYS WATCH for the words AT THE SAME TIME.

HOLDING STITCHES ON THE LEFT SIDE WHILE SHAPING THE RIGHT SIDE

There are different ways to hold stitches on one side while completing the other side. Usually, we tell you to bind off the center sts. for neck and put the left side into holding position while completing the right side. The easiest way and really the best way for beginners is to take a piece of RAVEL CORD and hand knit the center neck stitches, pulling them back against the needle bed of machine to the "A" or out of work position. The stitches remain in the HOOKS of the needles so you are really only knitting them HALF WAY. With another color of Ravel Cord, knit the remaining sts. on the left side in the SAME WAY.

It is important to protect these held stitches in some way—so you can either hang a REVERSING BAR so that the EYES of the Bar go BETWEEN the Gate Pegs on the machine and that the UPPER TIPS of Bar only—show above the needle bed...OR the simplest way is to use a piece of 1 inch masking tape and GENTLY place it beneath the knitting—right below the gate pegs. Do NOT press the tape—only enough pressure to hold it in place. This will prevent the Carriage (or Slide) from marking the held section.

It is VERY IMPORTANT that you mark the PATTERN ROW where you divide for the split for NECK (or SHOULDER) shaping... If you are using a PUNCH CARD—MARK THE CARD—if you are using an ELECTRONIC machine, MARK THE DESIGN WINDOW. Also take note of the Row number for the division. When you are ready to work the left section, bring the HELD stitches back to B (working) position by pulling each end of the Ravel Cord GENTLY and rip it off—be sure to align all needles straight in the B or knitting position.

Now you are ready to REFER TO YOUR OWN INSTRUCTION MANUAL for your machine—to set the controls to begin knitting the left half. The neck stitches can be bound off after completing the right side or you can leave them in hold until each side is finished, then bind them off or remove them onto contrast waste yarn ready to be picked up for knitting a neckband or for other finishing.

FULL FASHION DECREASING OR INCREASING

For Stockinette stitch, use the Full Fashion method for decreasing or increasing (except for regular cap shaping on sleeves where you decrease the edge stitch).

TO DECREASE: Hang the 3rd stitch onto the 2nd stitch then move the end stitches in to fill the empty needle.

TO INCREASE: Move the 2nd end stitches 1 needle outward, then pick up the 3rd stitch from the row below and hang it onto empty needle.

PATTERN SYMBOLS

() Symbol for 2nd size.

[] Symbol for 3rd size.

There are up to 3 sizes given for Patterns in KNITKING MAGAZINE. For example, the Charts and printed instructions will show the cast-on as... 124—First size. (132)—Second size. [140]—Third size.

R = ROW

◻ Needles in holding position.

⊗ Needles back into working position.

< For Short Row Knitting

THE SAMPLE SWATCH

Before you knit any garment, you must knit a sample swatch using the yarn you have chosen for your garment. If you do not get the correct Stitch and Row Gauge as given for a Pattern in KNITKING MAGAZINE—try different tensions. If you are using the specified yarn, you should be able to get the correct gauge using one of the tensions shown. If you are using other yarns, you may have to make several swatches—but the gauge is very important.

To make a sample swatch—Cast on 60 stitches with waste yarn and knit 6 rows. Mark the tension number for your sample swatch by making holes (you can do this with a Lace Carriage or by hand), 4 transfers for Tension 4, 6 transfers for Tension 6, etc. Knit 6 more rows.

Change to garment yarn and set Counter at 0. Knit 30 rows (in Stockinette stitch or Pattern stitch—according to the garment). With contrast waste yarn knit the 10th stitch FROM EACH SIDE—by hand. Knit 30 rows. Change to waste yarn and knit 12 rows. Remove the sts. from the machine by pushing the Carriage (or Slide) across without yarn.

Pull and stretch the sample swatch both lengthwise and diagonally from corner to corner, then lengthwise again. Gently block the swatch (KNITKING PRESSING CLOTHS are great for this)—or you can allow the sample to rest several

hours or even over night so that the stitches can return to their basic form. USE KNITKING CONVERTA TAPE for MEASURING YOUR SAMPLE (or the KNITKING INSTANT STITCH AND ROW GAUGE MEASURE).

If you use the Converta Tape, pull out the Tape to measure BETWEEN the 40 marked stitches in the center of your swatch. Move the red marker on the Tape so that it points to 40 stitches on the TAPE. Your stitch gauge to 2" (5 cm) will show in the RED WINDOW. To find the number of rows in 2" (5 cm), place the Tape to measure over the 60 rows, push the red marker to 60 on the Tape and your row gauge for 2" (5 cm) will show in the red window.

If you do not own a KNITKING CONVERTA TAPE or a Stitch and Row Measure, you must count the number of stitches and rows to 2" (5 cm) after marking a 2-inch square in the center of your knitting.

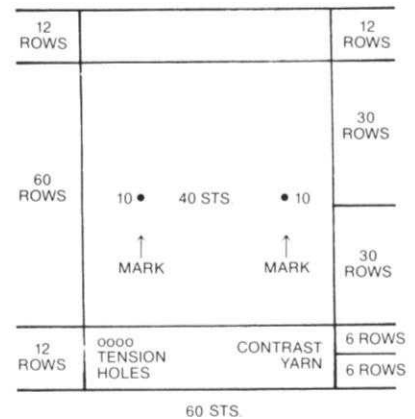

FINISHING

Gently block all sections—For PULLOVERS, JACKETS and DRESSES: Join the front to back at shoulders and sides. Sew sleeves together and set in. Hem lower edge and sleeve edges if needed. For a double neckband or armhole, band sew 1 edge to inside and 1 to the outside of neck or armhole. For a single ribbed band, sew 1 edge to the outside of neck or armhole edge. For a cardigan or jacket with buttonholes, finish buttonholes and sew on buttons.

PANTS: Join front to back at sides. Sew inside leg seams, then join to center front and back. Make hem at waistline and insert elastic. Hem lower edge of pants' legs.

◻ Needle not used—in out of work position.

3x1

4

The number in the box is the number of Rows between shapings. The 3 x 1 above the box gives you the sts. and number of times to make the decreases (or increases)—FOR EXAMPLE: 3 x 1 over the box with 4 means—At the given Row number, *decrease 1 st. knit 4 rows* and REPEAT from * to * 2 times more for a total of 3 times in all. All decreasing (or increasing) WITHOUT ROW NUMBER IN BOX must be made on EVERY 2nd ROW.



461



WOMAN'S TOP AND SKIRT

SIZES: 6/8 (10/12) [14/16]
YARN: Venetia
AMOUNT:
 color 1 1 1/2 1 1/2 2 lbs.
 color 2 8 oz. 8 oz. 8 oz.
TENSION: 4 to 5 Rib. 1.2/1.1 II
GAUGE: 17 sts. 23 rows = 2" (5 cm)

Stockinette stitch with INTARSIA DESIGN with Bands in K2, P2 Ribbing. Use INTARSIA CARRIAGE and hand feed the yarn.

BACK:

Cast on 162 (172) [182] sts. with color 1 and work 28 rows K2, P2 Ribbing. Transfer the ribber sts. to main machine and continue in INTARSIA DESIGN. MARK THE NEEDLE BED COUNTING FROM THE RIGHT SIDE OF KNITTING. 59 (62) [65] - 30, 14, 30, 14 - Work the first 59 (62) [65] sts. with color 1 and the remaining sts. with color 2. CONTINUE TO FOLLOW THE CHART for 16 rows then work 16 rows over ALL NEEDLES with Color 1. Work the first 59 (62) [65] sts. with color 1, then next 30 with color 2, the next 14 with color 1, the next 30 with color 2, the next 14 with color 1, and the remaining sts. with color 2. Continue in the same way for 16 rows. Work the next 16 rows over all needles with color 1. CONTINUE IN THIS WAY, FOLLOWING THE CHART. (See Picture). After Row 172 (174) [176], SHAPE ARMHOLE: ON EACH SIDE, bind off 6 sts. 1x, 2 sts. 3x, 1 st. 9x (10x) [11x]. After Row 254 (260) [266], SHAPE SHOULDER: ON EACH SIDE, bind off 8 sts. 3x, 7 sts. 2x. (8 sts. 5x). [9 sts. 2x, 8 sts. 3x]. After Row 264 (270) [276], bind off the remaining sts. or you can remove them onto contrast waste yarn.

FRONT:

Cast on 162 (172) [182] sts. with color 1 and work 28 rows K2, P2 Ribbing. Transfer the ribber sts. to main machine THEN MARK THE NEEDLE BED COUNTING FROM THE LEFT SIDE OF STS. IN WORK. Work the INTARSIA DESIGN IN REVERSE (SEE CHART). After Row 172 (174) [176], SHAPE ARMHOLE same as the back. After Row 220, divide in the center and complete the right side first. Put the needles on the left into holding position. *After Row 237 (241) [245], ON NECK SIDE, bind off 6 sts. 1x, 4 sts. 1x, 3 sts. 1x, 2 sts. 1x (2x) [3x], 1 st. 7x BUT AT THE SAME TIME, after Row 254 (260) [266], SHAPE SHOULDER same as the back. Bring the needles on the left into working position, knit 1 row to the left side, turn the Row Counter back to 220 and complete the left half. Follow the instructions from *.

SLEEVES:

Cast on 70 (74) [78] sts. with color 1 and work 24 rows K2, P2 Ribbing. Transfer the ribber sts. to main machine and continue in Stockinette stitch. ON EACH SIDE, increase 1 st. every 6th row 23x (24x) [25x]. After Row 182 (188) [194], SHAPE CAP: ON EACH SIDE, bind off 6 sts. 1x, 4 sts. 1x, 3 sts. 1x, 2 sts. 1x (2x) [3x], 1 st. 2x (3x) [4x], 1 st. every 3rd row 12x, 2 sts. 2x, 3 sts. 3x. After Row 242 (252) [262], bind off the remaining sts.

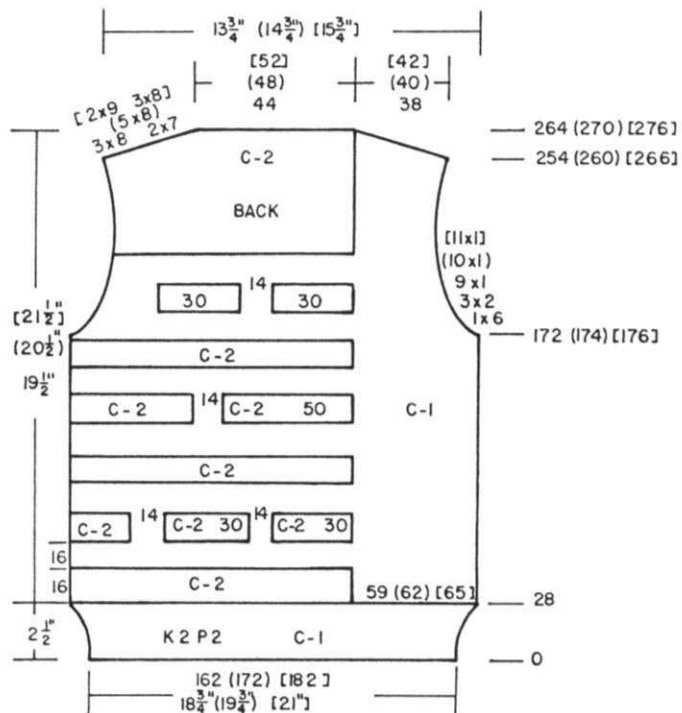
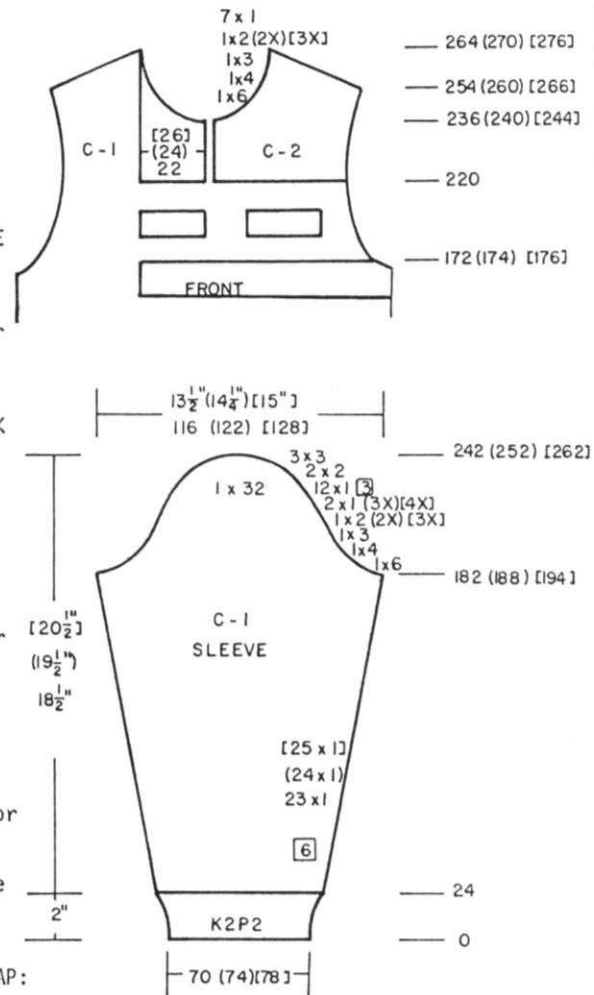

NECKBAND:

With color 2, cast on 122 (130) [138] sts. and work 12 rows K2, P2 Ribbing. Transfer the ribber sts. to main machine. Sew shoulders together then beginning with OPENING at front neck edge, pick up sts. around the neck and bind off LOOSELY. If it is difficult to pick up all the sts. at one time, pick up only half, bind these off then pick up the remaining sts. and bind off.

SKIRT: Make 2 sections.

With color 1, cast on 176 (186) [196] sts. and work Stockinette stitch.

With 1 tension lower than garment tension, knit 20 rows, then hang the hem.

Change to garment tension and WORK SHORT ROWS: ON OPPOSITE SIDE OF CARRIAGE, put into holding position 67 sts. BEFORE KNITTING the next 2 rows.

ON OPPOSITE SIDE OF CARRIAGE, bring back into working position 26 sts. 2x, 15 sts. 1x, ON EACH SIDE. COUNTER AT 0. Knit to Row 70 (80) [90].

ON EACH SIDE, decrease 1 st. every 30th row 4x, then 1 st. every 10th row 9x.

After Row 276 (286) [296], remove onto contrast waste yarn.

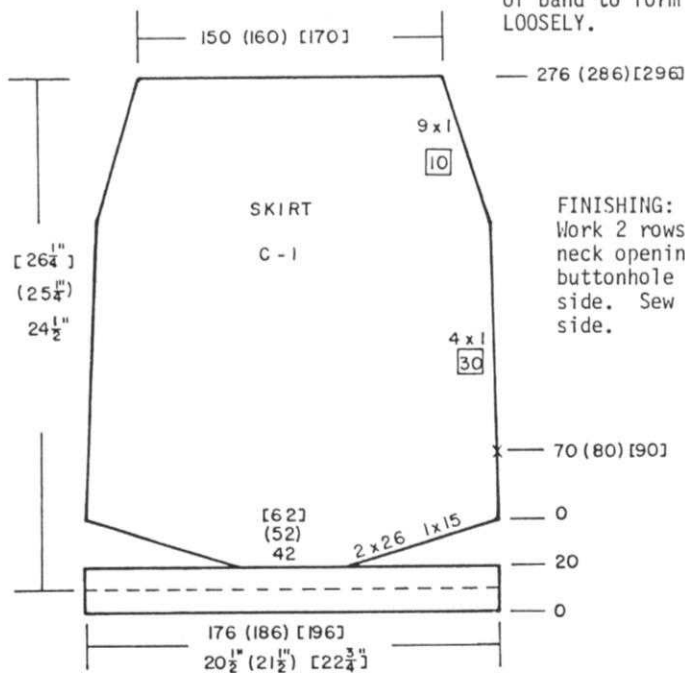
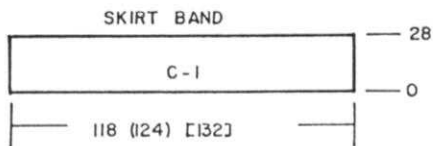
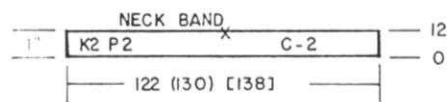

SKIRT WAIST BAND

Bring 118 (124) [132] needles into working position. Color 1. With wrong side facing you, hang Skirt waist onto machine *1 st. on each of 6 needles, then 3 sts. on ONE NEEDLE and REPEAT FROM *. Knit 1 row. Beginning with 2nd needle on the left, bring every other needle into 'D' or 'E' position. Set machine for SKIP or SLIP and knit 1 row. Release Skip or slip and over all needles knit 28 rows. Beginning with the first needle on the left, bring every other needle into selection (D) position then pick up the loops from first row of band to form hem. Bind off LOOSELY.

FINISHING: See General Instructions. Work 2 rows single crochet around neck opening, making a loop for buttonhole at top edge on one side. Sew on button at opposite side.

462



SLEEVELESS TOP WITH SINGLE MOTIF BUTTERFLY

SIZES: 6/8 (10/12) [14/16]

YARN: Color 1 = Roma
Color 2 = Angora

AMOUNT:
color 1 1/2 1/2 1/2 lb.
color 2 1 1 1 ball

TENSION: 4 Ribbing 0.1/0.1 for
Waist Bands II
1/1 for Neck and Sleeve
Bands II

GAUGE: 17 sts. 25 rows = 2" (5 cm)

BACK:

With color 1, cast on 149 (169) [187] sts. and work 38 rows K1, P1 Ribbing. Transfer the ribber sts. to main machine and increase 1 st. on the right side.

Continue in Stockinette stitch. Knit to Row 174 (178) [182].

ON EACH SIDE, bind off 10 sts. Knit to Row 274 (288) [302].

SHAPE SHOULDER: ON EACH SIDE, bind off

11 sts. 2x, 10 sts. 2x.
(12 sts. 4x)
(13 sts. 4x).

Bind off (or remove onto contrast waste yarn) the remaining sts.

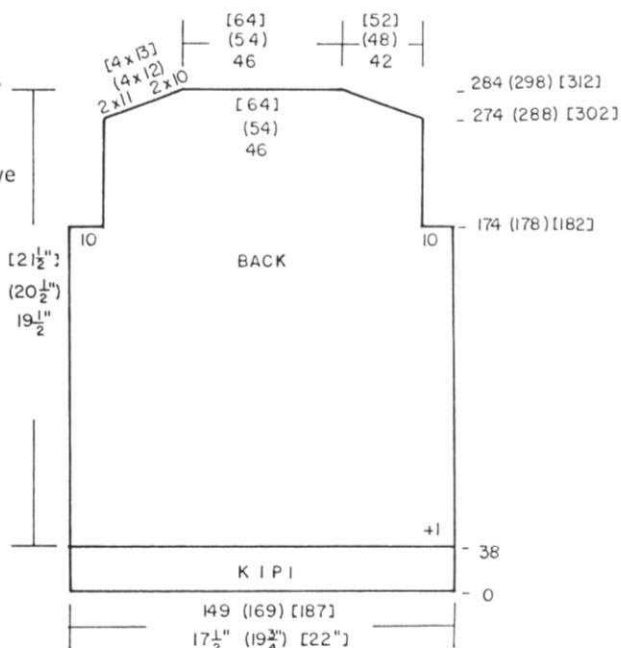

Made on the KH 910 machine. Stockinette stitch with a Single Motif Fair Isle design on the front section. Bands are K1, P1 Ribbing.

FRONT:

Work the front the same as the back to Row 134 (144) [154]. Center the single motif for Butterfly as shown on the mylar sheet and follow the chart to program the pattern. Work the Pattern but AT THE SAME TIME, after Row 174 (178) [182], ON EACH SIDE, bind off 10 sts.

When pattern is completed continue in Stockinette stitch to Row 224 (234) [244].

Bind off the center 16 (24) [34] sts., put the needles on the left into holding position and complete the right side first.

*ON NECK SIDE, bind off 5 sts. 1x, 4 sts. 1x, 3 sts. 1x, 2 sts. 1x, 1 st. 1x AND AT THE SAME TIME, After Row 274 (288) [302], SHAPE SHOULDER same as the back. Bring the needles on the left into working position, knit 1 row to the left side, turn the Row Counter back to 224 (234) [244] and complete the left half. Follow the instructions from *.

NECK BAND:

Cast on 136 (158) [180] with color 1 and work 24 rows K1, P1 Ribbing. Transfer the ribber sts. to main machine. Close one shoulder first, then pick up sts. around neckline from open shoulder to shoulder. Pick up 46 (54) [62] sts. across the back neck and 90 (104) [118] across the front neck. Knit 1 row then bind off LOOSELY.

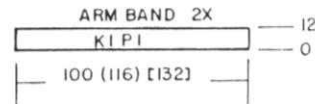
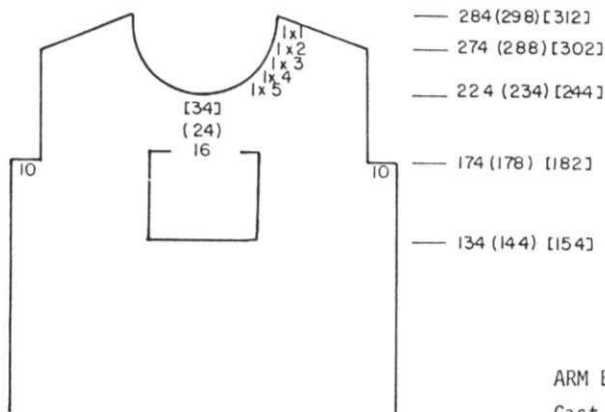

ARM BANDS:

Cast on 100 (116) [132] sts. and work 12 rows K1, P1 Ribbing. Transfer the ribber sts. to main machine, knit 1 row stockinette stitch then remove the sts. onto waste yarn. Both shoulders closed. Weave the open sts. into armhole leaving the 10 sts. at underarm free, then sew the edges of band into the 10 bound off sts. at underarm.

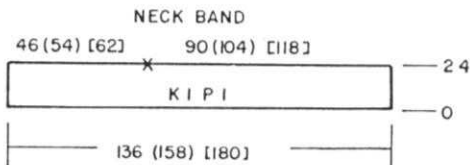

FINISHING:

See General Instructions.

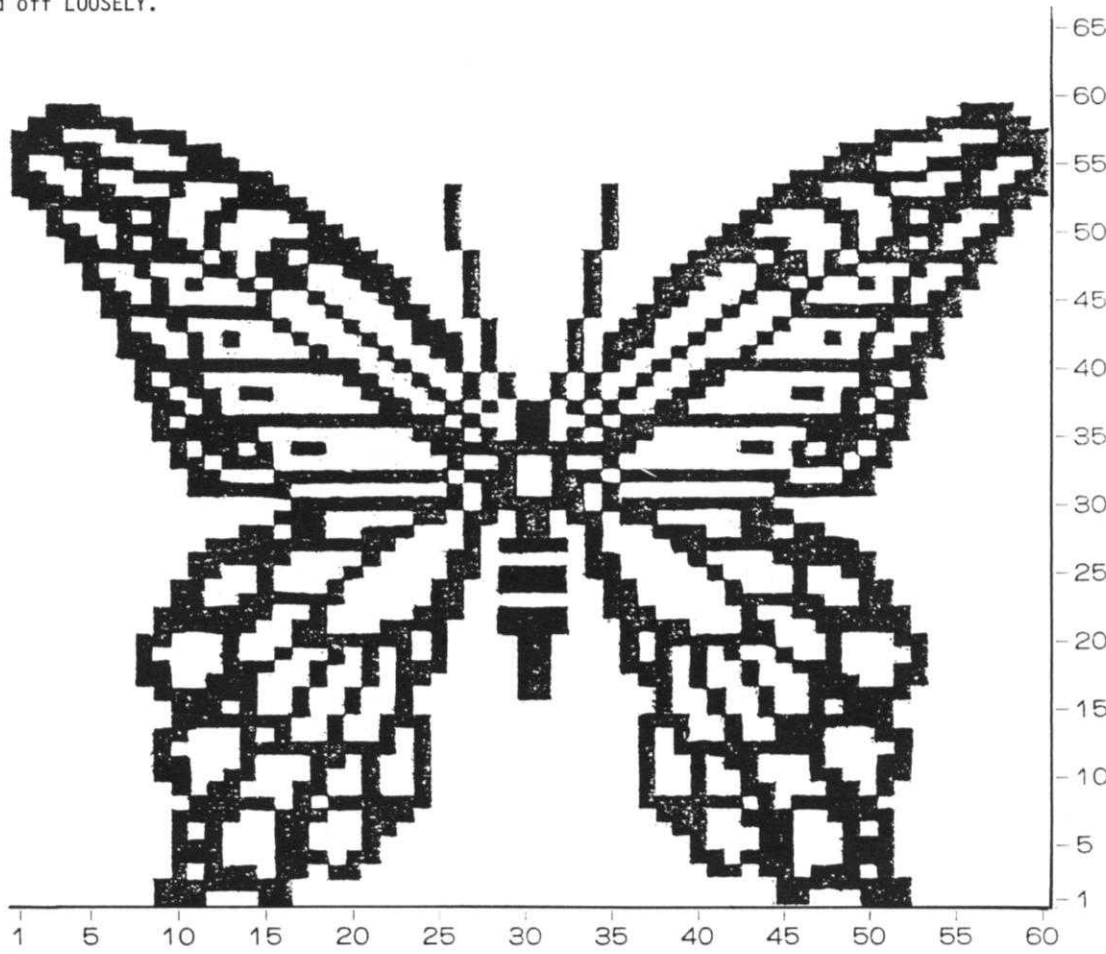
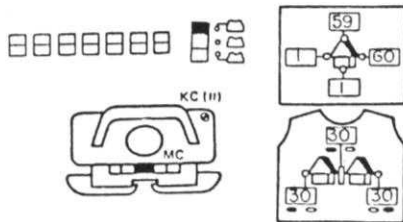



463



THREAD LACE TOP

SIZES: 6/8 (10/12) [14/16]
 YARN: Alanda= color 1, Mami-Rex= (fine) color 2.

AMOUNT:
 color 1 7 8 9 balls
 color 2 2 spools for all sizes.
 TENSION: 3 - Ribber -0/-0
 GAUGE: 8.5 sts. 13 rows = 2" (5 cm)

THREAD LACE KNITTING. Punch Card.
 Made on the KH 260 machine but the Ribbing is made on the KH 230. If you do not own a 230 ribber, you can latch up every other stitch into a knit stitch for the 1 x 1 ribbing.

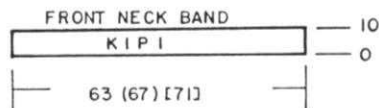
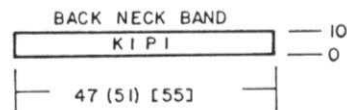

BACK NECK BAND:

Cast on 47 (51) [55] sts. with color 1 and work 10 rows K1, P1 Ribbing. Transfer the ribber sts. to main machine then pick up sts. across the back neck. Knit 1 row then bind off loosely.

FRONT NECK BAND:

Cast on 63 (67) [71] sts. with color 1 and work the same as for back neck band.

BACK:

With contrast waste yarn, cast on 82 (92) [98] sts. After knitting 9 to 11 rows, knit 1 row with Ravel Cord to the right side. Change to color 1 and Counter at 0. Knit 4 rows Stockinette stitch, SETTING THE PATTERN before knitting the 4th row. Continue in Pattern but REMEMBER to push back the 2 end needles on every row to working (A) position if they are selected. After Row 58 (62) [66], mark each side with a bit of contrast yarn for setting in sleeves. Continue in Pattern to Row 112 (120) [128]. Mark Row on Card. Bind off the center 32 (36) [40] sts. put the left into holding position by knitting each stitch by hand with a ravel cord and pull each stitch back to A position. Cover the left side sts. in hold with a small piece of masking tape to prevent carriage from marking or catching the sts. *ON NECK SIDE, bind off 3 sts. 1x, 2 sts. 1x, 1 st. 1x. After Row 118 (126) [134], stop pattern and knit 2 rows stockinette stitch with color 1. Remove the sts. onto contrast waste yarn. Bring the needles on the left into working position, remove waste yarn. Set Pattern to marked row on card and complete the left half. Follow the instructions from *.

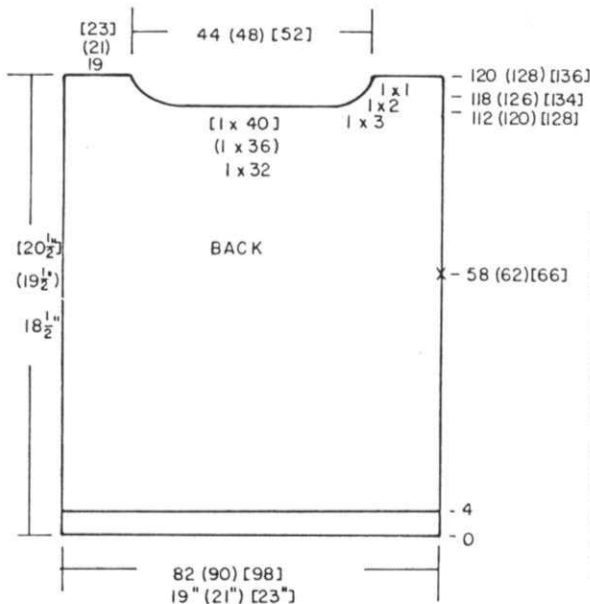

FRONT:

The front is worked the same as the back to Row 94 (102) [110]. Bind off the center 10 (14) [18] sts. for neck. Put the needles on the left into holding (A) position same as you did for the back and complete the right side first. Mark Row on Card. *ON NECK SIDE, bind off 4 sts. 1x, 3 sts. 1x, 2 sts. 3x, 1 st. 3x, 1 st. every 4th row 1x. After Row 118 (126) [134], stop Pattern and knit 2 rows Stockinette stitch with color 1. After Row 120 (128) [136], remove the sts. onto contrast waste yarn. Bring the needles on the left into working position. Set Pattern to marked row and complete the left half. Follow the instructions from *.

SLEEVES:

Begin and end with contrast waste yarn same as you did for back and front. Cast on 72 (80) [88] sts. and after the waste knitting, change to color 1 and counter at 0. Knit 4 rows Stockinette stitch then continue in Pattern same as you did before. After Row 88 (94) [100], stop Pattern and knit 2 rows Stockinette stitch with color 1. Remove the sts. onto contrast waste yarn.

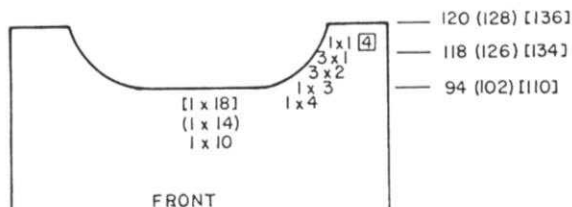
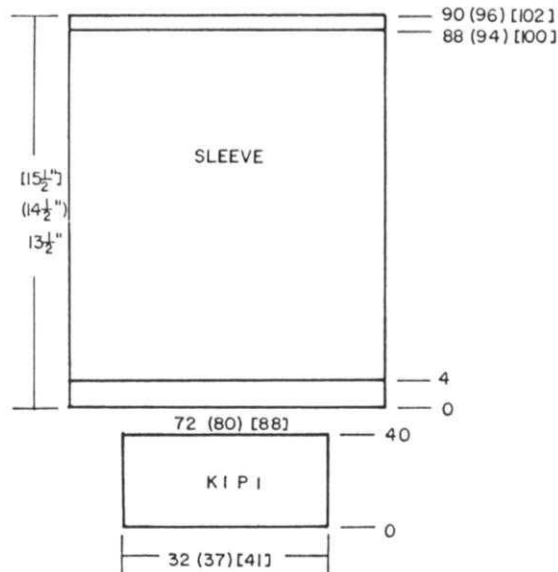

SLEEVE BANDS: Make 2.

With color 1, cast on 33 (37) [41] sts. and work 40 rows K1, P1 Ribbing. Transfer the ribber sts. to main machine and take the open sts. with 4 rows Stockinette stitch and hang them onto these needles decreasing evenly across. Knit 1 row then bind off loosely.

WAIST BAND: Make 2.
Cast on 75 (81) [87] sts. with color 1 and work 30 rows K1, P1 Ribbing. Transfer the ribber sts. to main machine then hang the sts. from waste yarn onto these needles decreasing evenly across. Knit 1 row then bind off loosely.

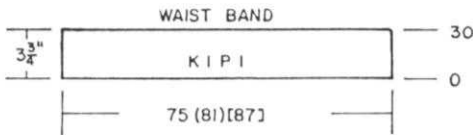

FINISHING:

See General Instructions.
Close shoulders and neck bands.
Sew up side seams. Match sleeves to marked edges then weave the open stitches to opening. Remove the waste knitting.

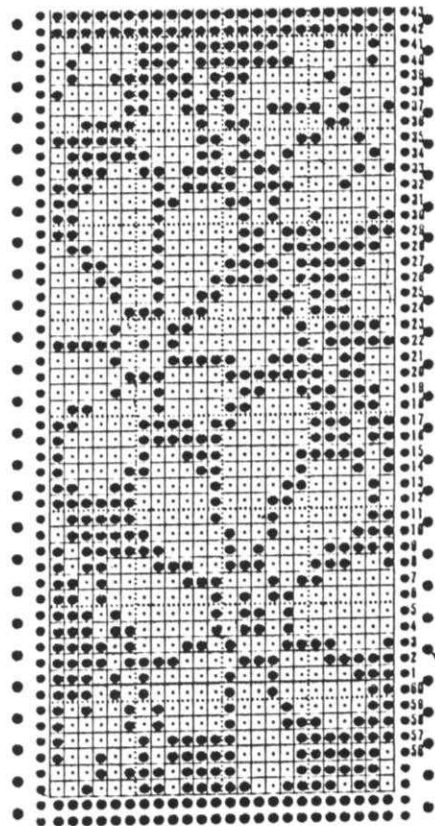

BLOUSE BACK:

With color 2, cast on 156 (170) [182] sts. and work the circular ribbing (or stockinette stitch - see Important Instructions) for 8 rows. Tension 3/3 II.
Change to Stockinette stitch, color 1 and continue in the color stripes as shown on color chart. After Row 142 (150) [158], ON EACH SIDE, increase 1 st. every 3rd row 9x.
Continue in color stripes. After Row 262 (278) [294], bind off the center 50 (54) [58] sts. for neck, put the needles on the left into holding position and complete the right side first.
*SHAPE SHOULDER AND NECK AT THE SAME TIME.
FOR SHOULDER, bind off 7 sts. 5x, 6 sts. 2x (8 sts. 3x, 7 sts. 4x) [8 sts. 7x]
FOR NECK, bind off 3 sts. 5x for all sizes.
Bring the needles on the left into working position, knit 1 row to the left (watch stripe) turn the Row Counter back to 262 (278) [294] and complete the left half. Follow the instructions from *.

464



WOMANS BLOUSE AND TUNIC

SIZES: 6/8 (10/12) [14/16]
YARN: Venetia
AMOUNT:
color 1 1 1/2 2 2 lbs.
color 2 1/2 1/2 1/2 1/2 lb.
TENSION: 4 to 5 Rib. 5/4 II
GAUGE: 17 sts. 25 rows = 5 cm (2")

Blouse is Stockinette stitch with color stripes. The Tunic is Stockinette stitch. All bands are full needle ribbing. You will need 3/4" rings to make the crochet buttons.

IMPORTANT INSTRUCTIONS.

FOR TUNIC: - The bands are full needle rib made circular for required number of rows as given. Be sure to follow the instructions from your Ribber Manual for making full needle ribbing and transferring the stitches to the main machine. If you do not own a ribber, you can make the bands in Stockinette stitch using a lower tension for the bands and then hang the hem.

FOR BLOUSE: - Follow the same instructions for the bands as given for the Tunic.

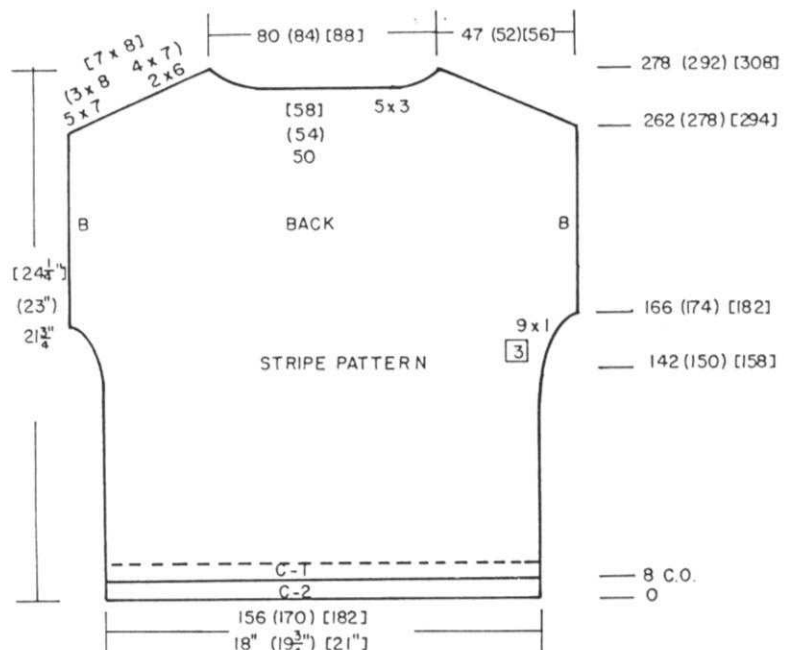

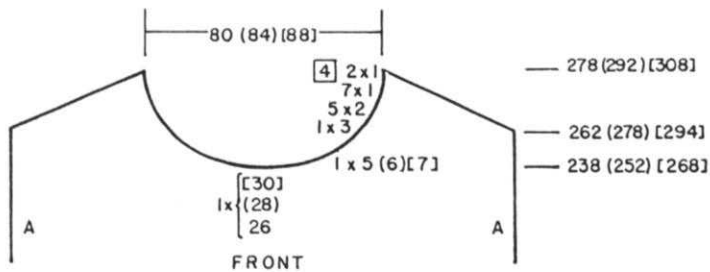

BLOUSE FRONT:

Work the front the same as the back to Row 238 (252) [268]. Bind off the center 26 (28) [30] sts., put the needles on the left into holding position and complete the right side first.
 *ON NECK SIDE, bind off 5 (6) [7] sts. 1x, 3 sts. 1x, 2 sts. 5x, 1 st. 7x, 1 st. every 4th row 2x AND AFTER ROW 262 (278) [294], SHAPE SHOULDER same as the back.
 Bring the needles on the left into working position, knit 1 row to the left, (watch stripe) turn the Row Counter back to 238 (252) [268] and complete the left half. Follow the instructions from *.

TUNIC BACK:

Please read the IMPORTANT INSTRUCTIONS before you knit this garment.
 Cast on 176 (188) [200] sts. and work the full needle circular ribbing to Row 12 Tension 3/3 II. Transfer the sts. from ribber to main machine then continue in Stockinette stitch.
 After Row 244 (252) [258] SHAPE ARMHOLE AND RAGLAN.
 FOR ALL DECREASES YOU WILL USE THE FULL FASHION METHOD AND YOU MUST TRANSFER THE 5th and 6th STITCH to the 7th and 8th NEEDLE. Use an adjustable 7 needle transfer tool to make it easy for you.
 ON EACH SIDE, transfer the 5th and 6th sts. to the 7th and 8th needle and move the edge sts. in to fill the empty needles.
 Decrease 2 sts. 3x, then 2 sts. every 3rd row 3x, 2 sts. every 4th row 19x (20x) [21x] then every 5th row decrease 2 sts. 7x and every 3rd row 2 sts. 2x. After Row 376 (388) [398] remove the remaining sts. onto contrast waste yarn.

TUNIC FRONT:

Work the front the same as the back to Row 244 (252) [258]. Work the armhole and raglan shaping in the same way as you did for the back as follows:
 ON EACH SIDE, decrease 2 sts. 3x then every 3rd row decrease 2 sts. 3x.
 After Row 272 (278) [282], divide in the center. Put the needles on the left into holding position and complete the right side first.

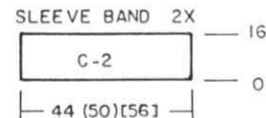
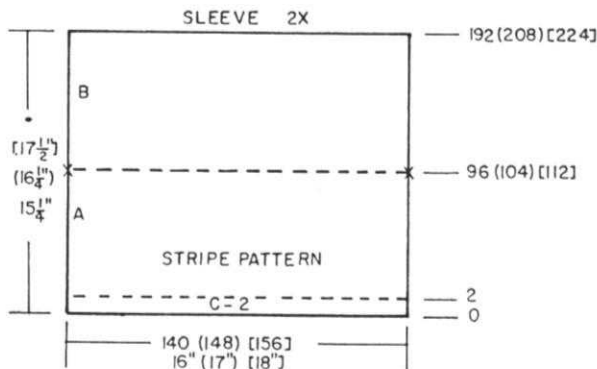

SLEEVE:

OPEN CAST ON with waste yarn. 140 (148) [156] sts. Knit 9 to 11 rows then 1 row with Ravel Cord to the right side. Change to color 2 and put Counter at 0.
 Knit 2 rows color 2 then continue in color stripes as shown on the Chart.
 After Row 96 (104) [112], mark each side with a bit of contrast yarn. then continue in stripes to Row 192 (208) [224]. Remove the sts. onto contrast waste yarn.

SLEEVE BANDS: Make 2

Cast on 44 (50) [56] sts. with color 2 and work 16 rows full needle rib (or Stockinette stitch) same as you did for the edge of front and back.
 With wrong side facing you, hang the center of sleeve edge marked X on the center needle then hang the remaining edge of sleeve on each side, dividing equally across. Knit 1 loose row then bind off.

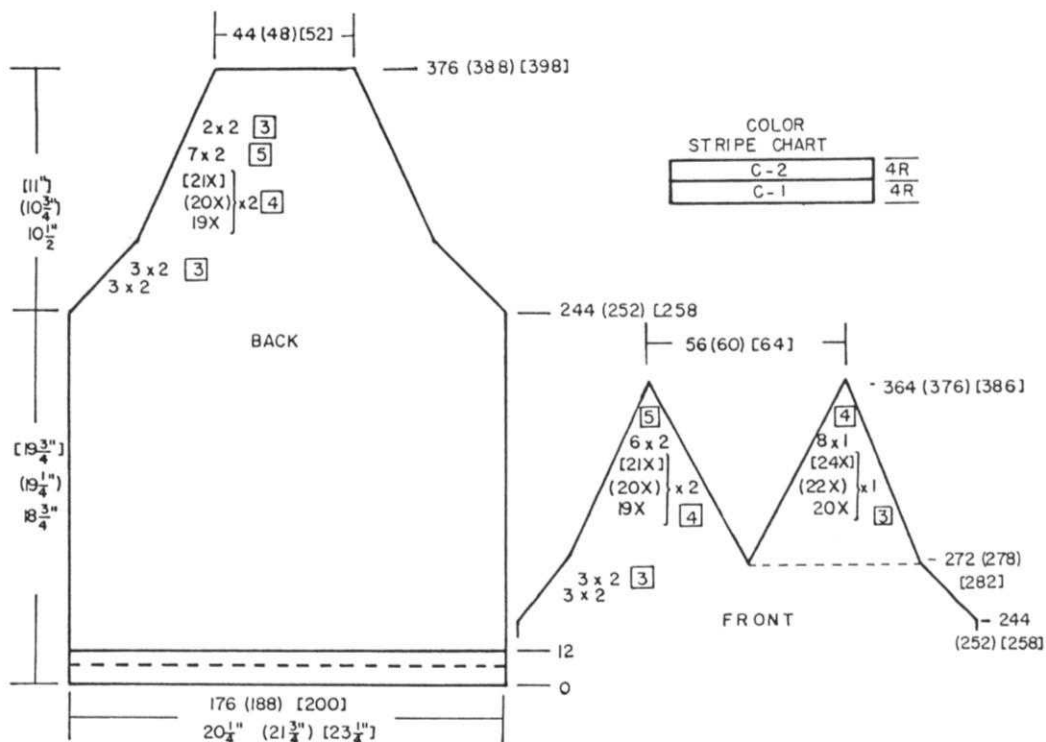

*Continue to shape raglan AS SHOWN ON THE CHART, and AT THE SAME TIME, SHAPE NECK as shown on the chart.
 After Row 364 (376) [386], bind off the remaining stitch.

Bring the needles on the left into working position, knit 1 row to the left side, turn the Row Counter back to 272 (278) [282] and complete left half. Follow the instructions from *.

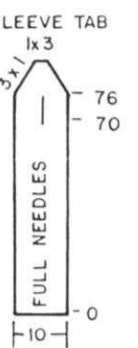
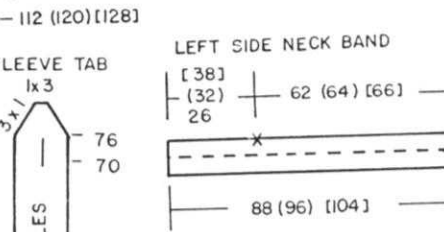
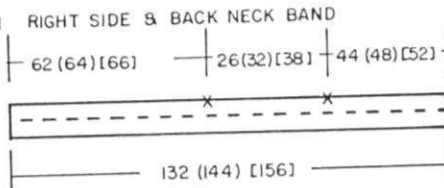
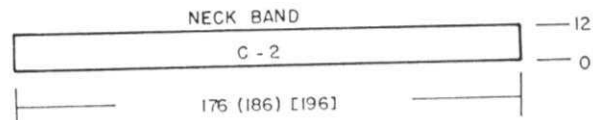
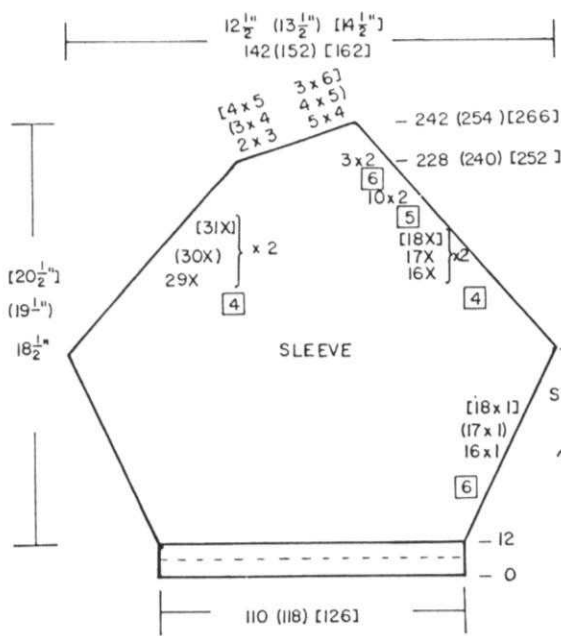

RIGHT SIDE & BACK NECK BAND
 Cast on 132 (144) [156] sts. and work 12 rows full needle circular ribbing same as you did before.
 12
 0 Transfer the ribber sts.
 Sew sleeves into garment first then with wrong side facing you, hang the neckline onto the machine as shown for your size on the chart. Knit 1 row then bind off loosely.

LEFT SIDE NECK BAND
 Cast on 88 [96] [104] sts. and work the same as the back neck band.

NECKBAND:
 With color 2, cast on 176 (186) [196] sts. and work 12 rows circular knitting (or Stockinette stitch) same as you did for other edges. Sew up one shoulder first, then pick up sts. around neckline from shoulder to shoulder with wrong side facing you (See Chart). Knit 1 loose row then bind off.

FINISHING: See General Instructions. Pull 1/4" elastic through sleeve band.

FINISHING: See General Instructions. Make 2 buttons by working double crochet over a 3/4" plastic ring until it is filled completely. Turn to the center and gather tightly. Sew button on sleeves approximately 8" (9") [10"] down from the neck opening on the right side of sleeve. Sew Tab on the wrong side approximately 10" (11") [12"] down from neck opening. Fold sleeve edge to the right side to form cuff and button it with Tab buttonhole. (See Picture).

SLEEVES: Make 1, reverse 1.
 Cast on 110 (118) [126] sts. and work the full needle circular ribbing same as you did before. Transfer the ribber sts. to main machine and continue in Stockinette stitch.
 ON EACH SIDE, increase 1 st. every 6th row 16x (17x) [18x]. After Row 112 (120) [128], work the DIFFERENT decreases ON EACH SIDE as shown on the chart for YOUR SIZE.
 After Row 228 (240) [252], work SHORT ROWS.
 ON OPPOSITE SIDE OF CARRIAGE, put into holding position
 3 sts. 2x, 4 sts. 5x
 (4 sts. 3x, 5 sts. 4x)
 [5 sts. 4x, 6 sts. 3x].
 Bring all the needles into working position, knit 1 row then bind off loosely.

SLEEVE TAB: Make 2.
 Cast on 10 sts. and work full needle ribbing with tension 5/4 II to Row 70. Divide in the center and work Buttonhole. Put the needles on the left into holding position and knit 6 rows then put these needles into holding position and work 6 rows over the left side. Counter at 76.
 WORK SHORT ROWS: *ON OPPOSITE SIDE OF CARRIAGE, transfer 1 st. from ribber to main machine then put this stitch into holding position. REPEAT FROM * until you have transferred 3 sts. ON EACH SIDE. Transfer the remaining sts. from ribber to main machine. Push needles OPPOSITE CARRIAGE back into working position before knitting the next 2 rows. Bind off loosely.

IT'S READY NOW!

KNITTING MAGAZINE BOUND VOLUME 19

- HARD BOARD COVER
- COMPLETE INSTRUCTIONS
- WILL HOLD ANOTHER COMPLETE VOLUME

PRICE \$23.95
 Shipping Costs \$3.25





465

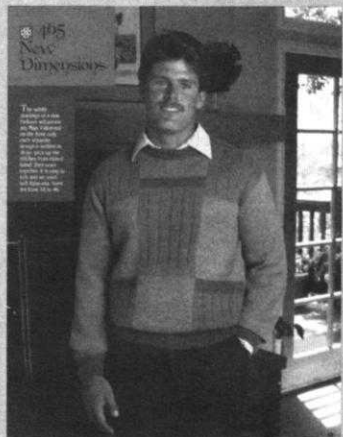

MENS PULLOVER

SIZES: 38/40 (42/44) [46]

YARN: Alpaca

AMOUNT:

color 1	10	10	10 balls
color 2	2	2	2 balls
color 3	2	2	2 balls
color 4	1	1	1 balls

TENSION: 8 Ribber 8/7 II

GAUGE: 14 sts. 18 rows = 2" (2")

The back and the sleeves are Stockinette stitch. The front has boxed pattern and is knitted in strips after the ribbing band at lower edge. Change colors and set up pattern following the Charts. All bands are K1, P1 Ribbing.

FRONT:

SPECIAL INSTRUCTIONS:

The front section is made in 3 separate sections after ribbed waistband. The Ribber is used for the pattern and there are 2 sts. on the Ribber with specified sts. in between on the main machine as SHOWN ON THE CHARTS. The instructions for setting the ribber needles is as follows.

HALF PITCH LEVER ON P

Transfer every 7th needle (or whatever is shown on Chart) to the Ribber. Push empty needle out of work (A position).

Move half pitch lever to H.

Pick up next stitch FROM ROW BELOW ON THE RIGHT SIDE OF EMPTY NEEDLE on main machine and place it onto the next right needle of Ribber. There are now 2 sts. side by side on the ribber.

When you have completed a section of Ribbing Pattern, transfer both Ribber stitches to the empty needle on the main machine to work the Stockinette part.

Cast on 137 (147) [161] sts. with color 2 and work 32 rows K1, P1 Ribbing. Transfer the ribber sts. to main machine and knit 1 row. REMOVE EACH SECTION ONTO CONTRAST WASTE YARN - 48 (52) [57] sts. on the right side, then the center 41 (43) [47] sts. in the center and then the remaining sts. on the left. Use a different color waste yarn for each section to make it easy for you to pick up the sts.

RIGHT FRONT: Watch the color changes. Pick up the right side of band (48 (52) [57] sts.).

FOLLOW THE CHART FOR THE RIGHT FRONT. When completed, pick up the center 41 (43) [47] sts. from the band and work in the same way, following the Chart.

When completed, pick up the remaining sts. and follow the Chart for the right front BUT REVERSE THE SHAPINGS.

BACK:

With color 2, cast on 137 (147) [161] sts. and work 32 rows K1, P1 Ribbing. Transfer the ribber sts. to main machine and work Stockinette stitch. Counter at 0.

After Row 122 (128) [134], SHAPE ARM-HOLE: ON EACH SIDE, work FULL FASHION DECREASES - 2 sts. every 4th row 6x (7x) [8x]. Continue knitting to Row 194 (204) [214].

Bind off the center 25 (27) [31] sts., put the needles on the left into holding position and complete the right side first.

*ON NECK SIDE, bind off 2 sts. 4x and AT THE SAME TIME FOR SHOULDER, bind off 8 sts. 1x, 7 sts. 4x (8 sts. 3x, 7 sts. 2x) [9 sts. 1x, 8 sts. 4x]. Bring the needles on the left into working position, knit 1 row to the left side, turn the Row Counter back to 194 (204) [214] and complete the left half. Follow the instructions from *.

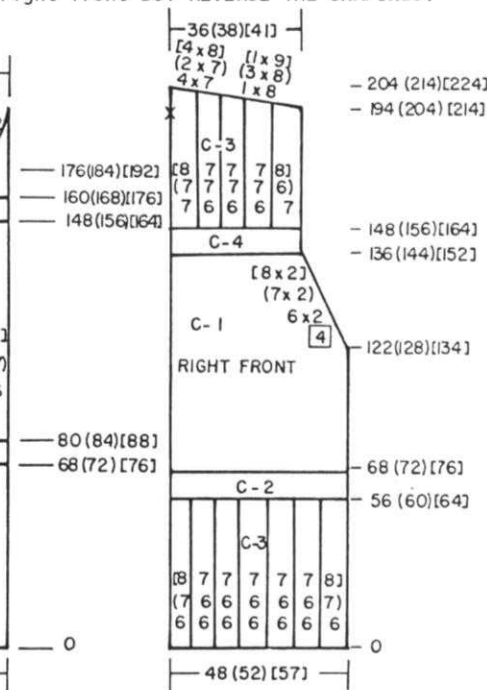
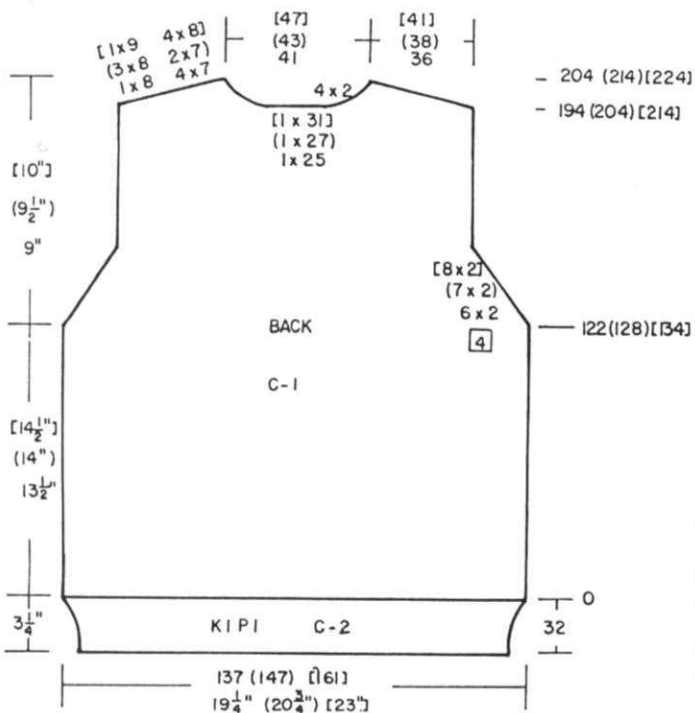

SLEEVES:

Cast on 73 (77) [81] sts. with color 2 and work 28 rows K1, P1 Ribbing. Transfer the ribber sts. to main machine and increase 1 st. on the right edge. Change to color 1. Continue in Stockinette stitch. ON EACH SIDE, decrease 1 st. (FULL FASHION METHOD) every 8th row 15x (16x) [17x].

After Row 154 (164) [172] ON EACH SIDE, decrease 2 sts. by transferring the 2nd and 3rd sts. to the 4th and 5th needles. Work the decreases every 4th row 12x (13x) [14x]. After Row 202 (216) [228], bind off the remaining sts. or you can remove them onto waste yarn.

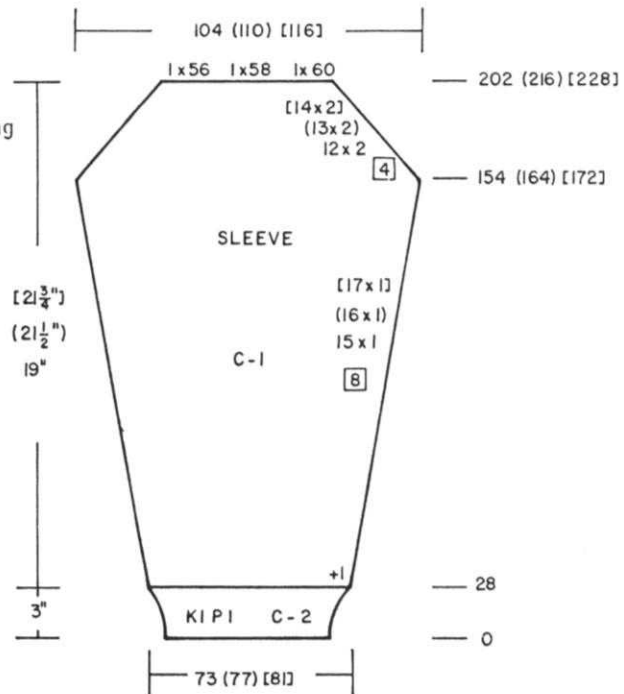
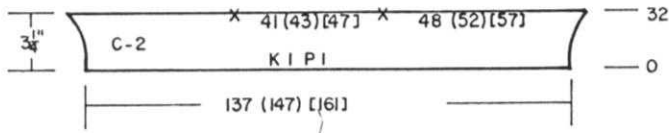

NECKBAND: WEAWE FRONT SECTIONS TOGETHER.

With color 2, cast on 117 (125) [133] sts. and work 14 rows K1, P1 Ribbing. Transfer the ribber sts. to main machine. SEW UP 1 SHOULDER FIRST then with wrong side facing you pick up 46 (48) [52] sts. along back neck and the remaining sts. for front neck and hang onto band. Knit 1 row then bind off LOOSELY.

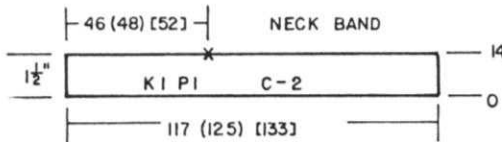

FINISHING: See General Instructions.

466



WOMENS FLOWER TUNIC

SIZES: 10/12 (14/16) [18/20]
YARN: Venetia, Beatrice, Angora
AMOUNT:
 color 1 1 lb. 3 oz. - Venetia
 color 2 1 ball - Beatrice-Leaves
 color 3 1 ball - Angora- Flower
 color 4 1 ball - Angora- Flower
 color 5 1 ball - Angora- Flower
 color 6 1 ball - Angora- Flower
TENSION: 6 - Garter St. T-5
GAUGE: 15 sts. 23 rows = 2" (5 cm)

Made on the KH 910 with Electric Carriage for Garter Stitch. Draw Design on Mylar Sheet and follow the Charts for setting and placement of Designs.

GARTER STITCH: Use Pattern No. 1-1 that is part of Set of Sheets the come with your 910 machine. See your Instruction Manual for KG 88 for setting Pattern for Garter Stitch.

BACK:

LATCH TOOL CAST ON - 148 (164) [180] sts. with color 1 (see your Instruction Manual for making the Latch Tool Cast on). Knit 1 row stockinette stitch then set **ELECTRIC CARRIAGE** for **GARTER STITCH**. With Tension 5, work to Row 22 in **GARTER** Stitch. Change to regular Carriage and continue in Stockinette stitch with Tension 6. After Row 94, ON EACH SIDE, cast on 5 sts. After Row 258 (262) [266], mark each side with bit of contrast yarn for setting in sleeves. After Row 290 (294) [298] divide in the center. Put the needles on the left into holding position and complete the right side first. *ON NECK SIDE, decrease 1 st. every 2nd row 13x (16x) [19x] then 1 st. every 3rd row 20x for all sizes. After Row 378 (388) [398], bind off (or remove onto waste yarn) the remaining sts.

Bring the needles on the left into working position, knit 1 row to the left side, turn the Row Counter back to 290 (294) [298] and complete the left half. Follow the instructions from *.

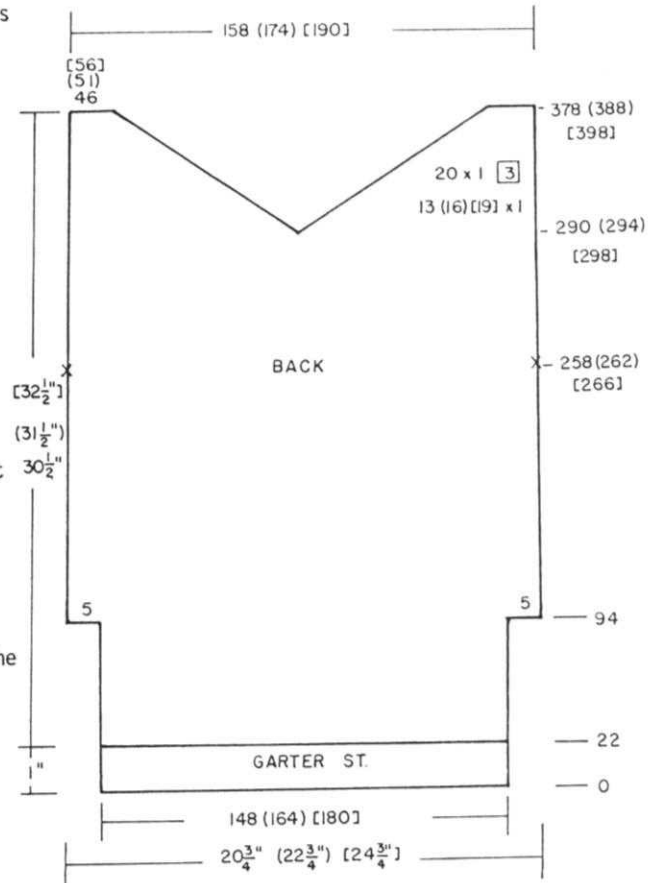

FRONT:

Work the front the same as the back to Row 24.
 Work Pattern No. 1 as shown on the Chart.
 After Row 94, ON EACH SIDE, cast on 5 sts. After Row 106, work Pattern No. 2 according to Chart.
 Work Pattern No. 3 after Row 188.
 After Row 258 (262) [266], mark each side with bit of yarn as you did before.

Work Pattern No. 4 after Row 270.
 After Row 344 (352) [358], divide in the center.
 Put the needles on the left into holding position and complete the right side first.
 *ON NECK SIDE, decrease 1 st. EVERY ROW 33x (36x) [39x].
 After Row 378 (388) [398], bind off (or remove onto waste yarn) the remaining sts.

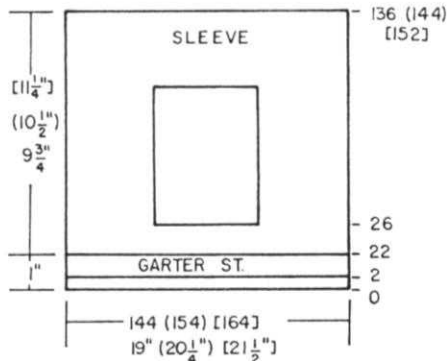
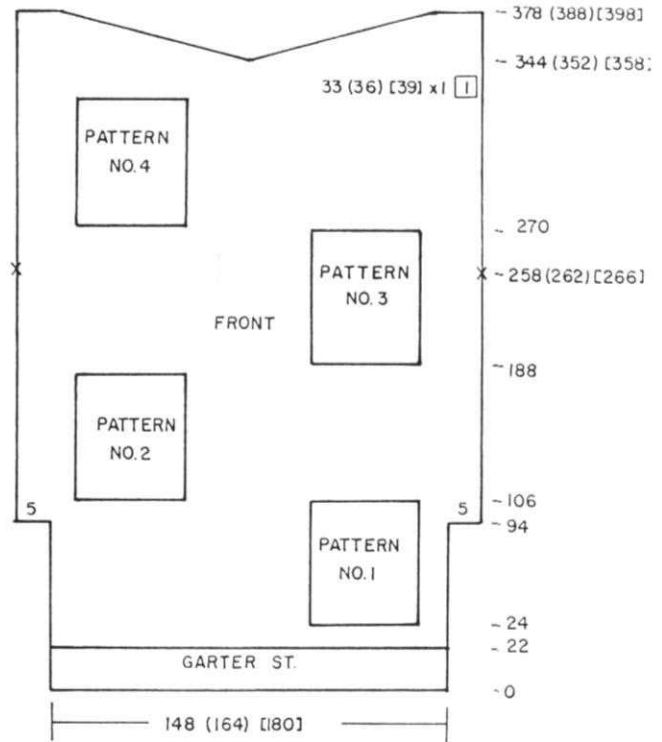

RIGHT SLEEVE:

With color 1, cast on 144 (154) [164] using the Crochet cast on same as you did for front and back. Knit 1 row Stockinette stitch then continue in Garter Stitch with Tension 5 to Row 22. Change to regular Carriage. Continue in Stockinette stitch with Tension 6.
 After Row 26, work the RIGHT SLEEVE PATTERN as shown on the Chart.
 After Row 136 (144) [152], bind off or remove the sts. onto contrast waste yarn.
 WORK THE LEFT SLEEVE THE SAME EXCEPT BUTTON NO. 1 must be in the DOWN position.

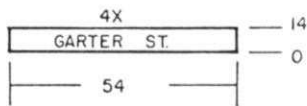

BANDS FOR SIDE SLITS: Make 4.

With color 1, cast on 54 sts. and with Tension 5, work in GARTER STITCH same as you did before to Row 14.
 With wrong side of garment facing you, hang 1 side opening onto this sts. then bind off LOOSELY. REPEAT for other three openings.

FINISHING:

See General Instructions.
 Close shoulders and work 2 rows single crochet around neckline.

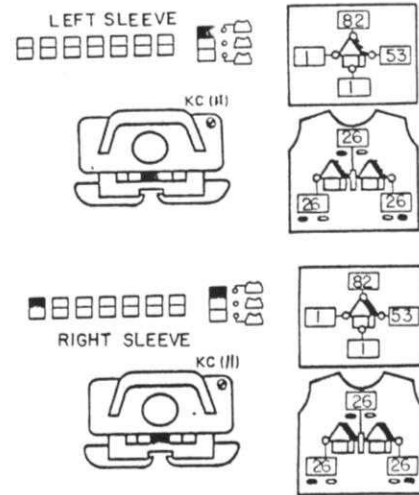
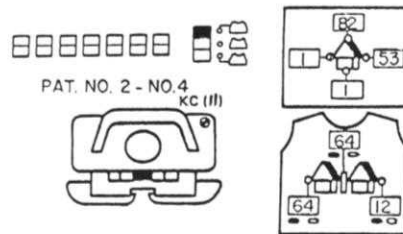
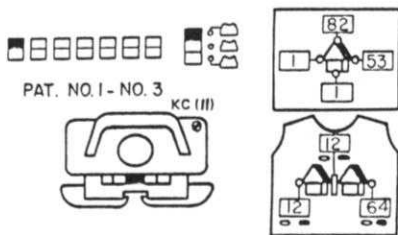

Continued

MACHINE KNITTING **FASHION**

The leading knitting publication from England. It contains 36 complete and outstanding patterns for women, men and children. Illustrated in full color this edition (8 1/2"x11") has a special group of patterns using the Garter Carriage.

Garments are knitted with Punch Card, Electronic and Bulky machines. At \$6.95 postpaid anywhere in the world, its definitely a 'Best Buy'.

Order direct from KNITKING
 1128 Crenshaw Blvd., Los Angeles CA 90019



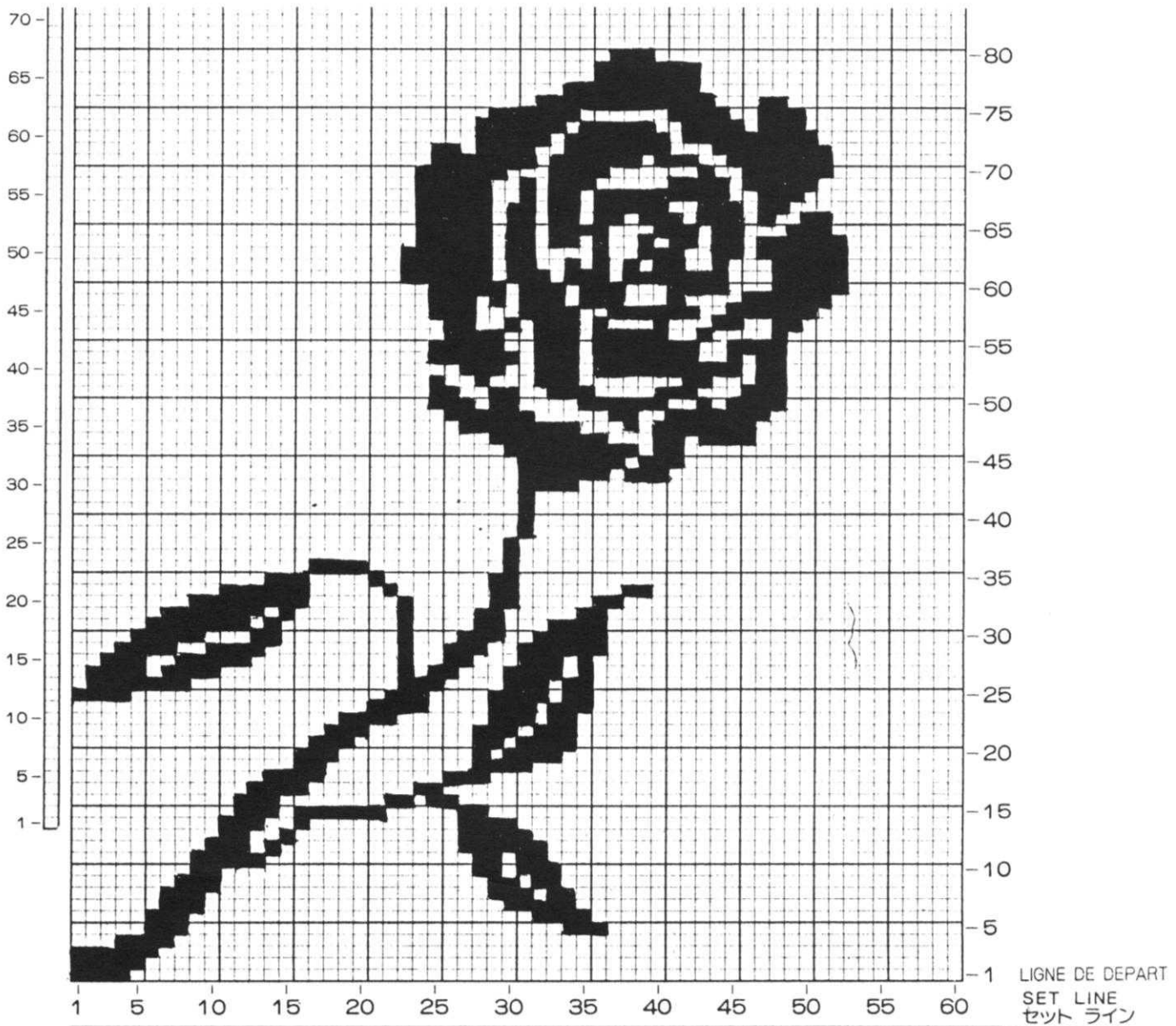

467



WOMENS JACKET & SKIRT

SIZES: 6/8 (10/12) [14/16]

YARN: Venetia

AMOUNT:

color 1 1 1/2 lbs. for all sizes.

color 2 1/2 lb. for all sizes.

TENSION: 6 for Jacket

5.1 for Skirt

3/3 II for slit back band

5.1 for slit front band

GAUGE: -17 sts., 23 rows = 2" (5 cm)

Jacket.

16 sts. 25 rows = 2" (5 cm)

Skirt

The Jacket is knitted with a Fair Isle Design. Punch Card. The Skirt is Stockinette stitch. Bands on Jacket are Stockinette stitch with Stripes. Front band slit on skirt is Stockinette stitch. Back band slit on skirt is full needle ribbing. Skirt lower edge is full needle ribbing.

JACKET BACK:

With color 1, cast on 152 (162) [172] sts. TENSION 4. Work 16 rows color 1

4 rows color 2, 4 rows color 1.

Hang the hem then continue in Pattern using TENSION 5.1.

Knit in Pattern to Row 182 (190)

[198].

SHAPE ARMHOLE: ON EACH SIDE, bind off

5 sts. 1x, 4 sts. 1x, 2 sts. 2x,

1 st. every 3rd row 6x.

Knit to Row 268 (280) [292].

SHAPE SHOULDER: ON EACH SIDE, bind off

10 sts. 2x, 9 sts. 2x.

(10 sts. 4x)

[11 sts. 2x, 10 sts. 2x].

After Row 276 (288) [300], bind off the remaining sts.

LEFT FRONT:

Cast on 75 (80) [85] sts. with color 1 and work the first 24 rows same as you did for the back EXCEPT ON THE RIGHT SIDE, INCREASE 1 st. every 3rd row 3x, knit 6 rows then DECREASE 1 st. every 3rd row 3x. After Row 24, hang the hem and CONTINUE IN PATTERN with Tension 5. After Row 182 (190) [198], SHAPE ARMHOLE same as you did for the back. After Row 230 (240) [250], SHAPE NECK: Bind off 4 (6) [8] sts. then bind off 4 (5) [6] sts. then 3 sts. 1x, 2 sts. 1x, 1 st. 5x AND AFTER ROW 267 (279)[291], SHAPE SHOULDER same as the back. WORK THE RIGHT FRONT WITH REVERSE SHAPING.

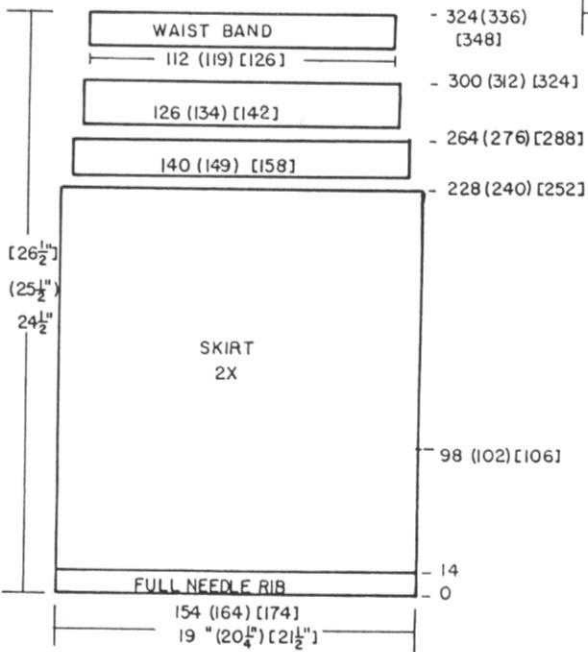
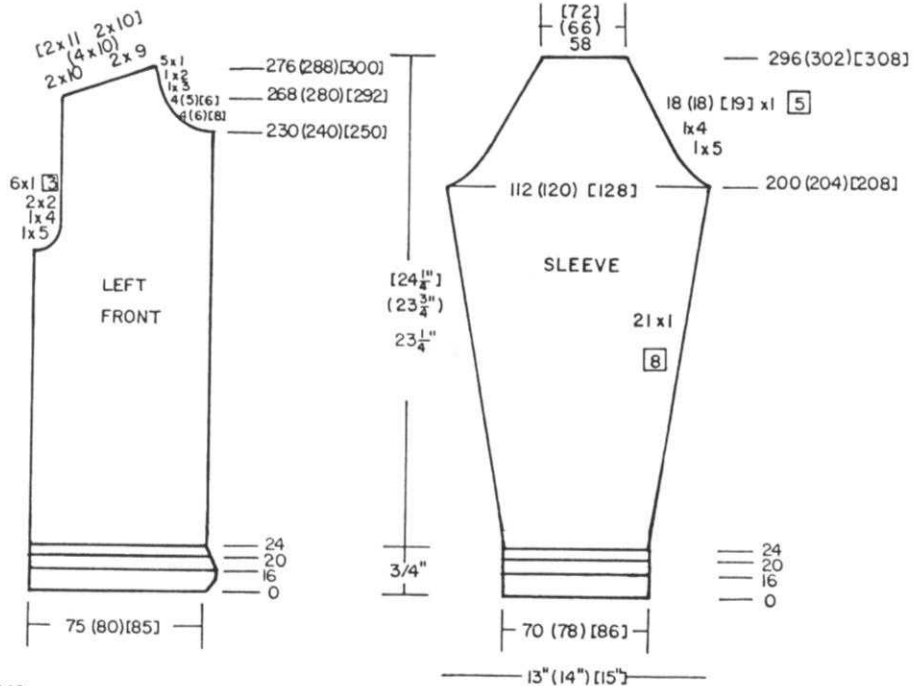

SKIRT: Make 2 sections.

With color 1, cast on 154 (164) [174] sts. FULL NEEDLE RIB for 14 rows with Tension 3/3 II. Transfer the ribber sts. to main machine (2 sts. each needle). Change to Tension 5.1 and continue in Stockinette stitch. Mark Row 98 (102) [106] on the RIGHT EDGE (left edge for second section) for slit. After Row 228 (240) [252], remove the sts. onto contrast waste yarn. Hang the sts. back onto the machine, decreasing across - 1 st. 14x (15x) [16x]. Remove the waste yarn. Counter 228 (240) [252]. Knit to Row 264 (276) [288]. Remove the sts. onto waste yarn same as before and hang back onto machine decreasing across same as before. Remove waste yarn and counter should read 264 (276) [288]. Knit to Row 300 (312) [324]. Remove the sts. onto waste yarn and hang them back the same as before. Remove the waste yarn. Counter 300 (312) [324]. MARK NEXT ROW. Change Tension to 4 and knit to Row 324 (336) [348]. Hang the marked row then bind off LOOSELY.

SLEEVES:

Cast on 70 (78) [86] sts. with color 1 and work the first 24 rows same as for the back. After Row 24, hang the hem same as the back then continue in Pattern. ON EACH SIDE, increase 1 st. every 3th row 21x. After Row 200 (204) [208] SHAPE CAP: ON EACH SIDE, bind off 5 sts. 1x, 4 sts. 1x, 1 st. every 5th row 18x (18x) [19x]. After Row 296 (302) [308], bind off the remaining sts.

BANDS FOR THE SLIT

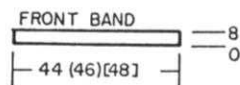

FRONT SLIT BAND: Stockinette stitch.

With wrong side facing you, pick up the LOOPS from front slit 44 (46) [48] sts. With TENSION 5.1, knit 8 rows. Remove the sts. onto contrast waste yarn. Fold band to the inside and hem in place going through the open sts. Remove waste yarn.

BACK SLIT BAND:

With color 1, cast on 57 (60) [63] sts. FULL NEEDLE RIB. Tension 3/3 II. Knit 14 rows. Transfer the ribber sts. to main machine, knit 1 row then with wrong side facing you, hang the back edge of slit onto these needles then bind off.

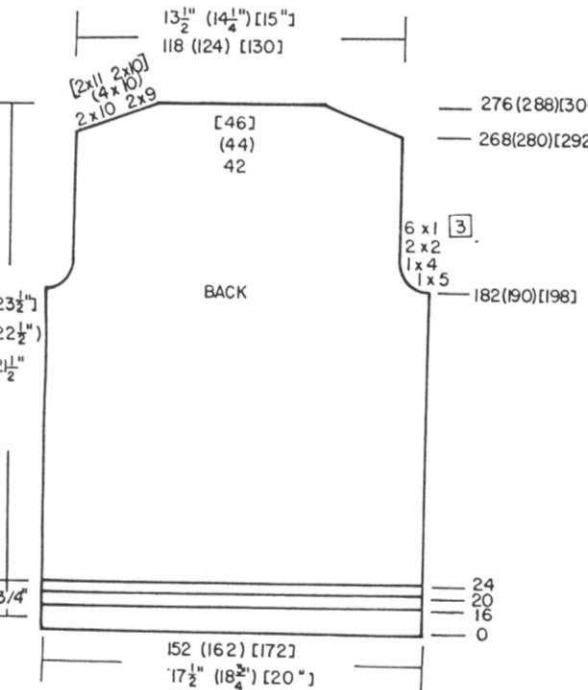
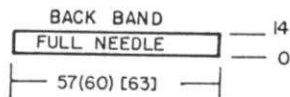

FRONT BANDS: Make 2

With color 1, cast on 109 (114) [119] sts. and work Stockinette stitch WITH TENSION 6. Knit 4 rows color 1, 4 rows color 2, then continue with color 1 BUT AT THE SAME TIME, ON EACH SIDE, increase 1 st. every 3rd row 3x. Knit 6 rows then ON EACH side decrease 1 st. every 3rd row 3x. After Row 24, hang the hem. With wrong side facing you, pick up sts. along front edge and bind off loosely.

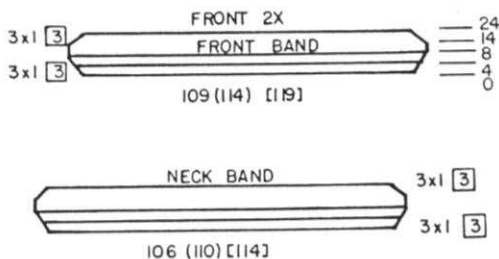

BOW: FULL NEEDLE RIB -TEN: 5/5 II

Cast on 25 sts. with color 1. Work full needle ribbing to Row 400. Transfer the ribber sts. to main machine and bind off.

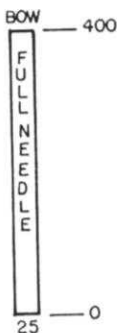

NECKBAND: TENSION 5.

With color 1, cast on 106 (110) [114] sts. and work Stockinette stitch. Make the color stripes same as for front bands and AT THE SAME TIME, ON EACH SIDE, increase 1 st. every 3rd row 3x, knit 6 rows then decrease 1 st. every 3rd row 3x. After Row 24, hang the hem. Pick up sts. around the neckline and bind off loosely.

FINISHING: See General Instructions.

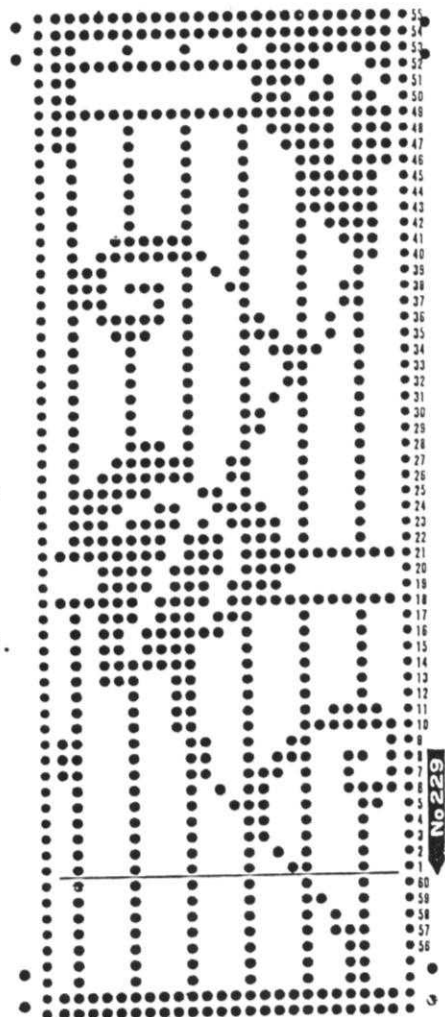

468



BACK and FRONT: The same but omit the boat on the back-section.

Cast on 69 (75) [81] sts. with color 1 and work 16 rows K1, P1 Ribbing.

Transfer the ribber sts. to main machine and continue in Stockinette stitch.

Knit to Row 84 (88) [92]. **SHAPE ARMHOLE: ON EACH SIDE, bind off 3 sts. 2x, 1 st. 2x, then every 4th row 1 st. 2 (3) [4]x BE SURE TO USE THE FULL FASHION METHOD for the decreasing of 1 st. by hanging the 2nd st. on the 3rd needle and move the end st. in to fill empty needle.**

Knit to Row 124 (130) [136]. Transfer every other stitch to the ribber and work K1, P1 Ribbing to Row 132 (138) [144]. Transfer the ribber sts. to main machine and bind off LOOSELY.

FRONT:

The front is worked the same as the back but after Row 54 (58) [62] Work the INTARSIA DESIGN in the Center.

3 rows Color 1 and color 2
25 rows Color 1 and color 3
7 rows Color 1 and color 4

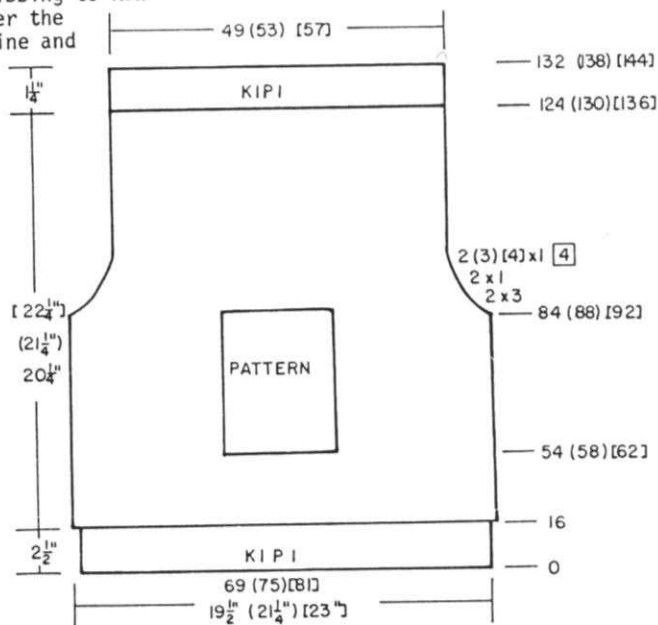

WOMENS PULLOVER

SIZES: 8/10 (12/14) [16/18]
YARN: BRAVO

AMOUNT:
color 1 10 10 11 balls
color 2 small amount - Blue
color 3 small amount - Red
color 4 small amount - Yellow
TENSION: 8 Ribber 3/3
GAUGE: 7 sts. 10.5 rows = 5 cm (2")

Made on the KH 230 Machine with Ribber. Use the INTARSIA method for knitting the Boat Motif on the front section. Bands are K1, P1 Ribbing.

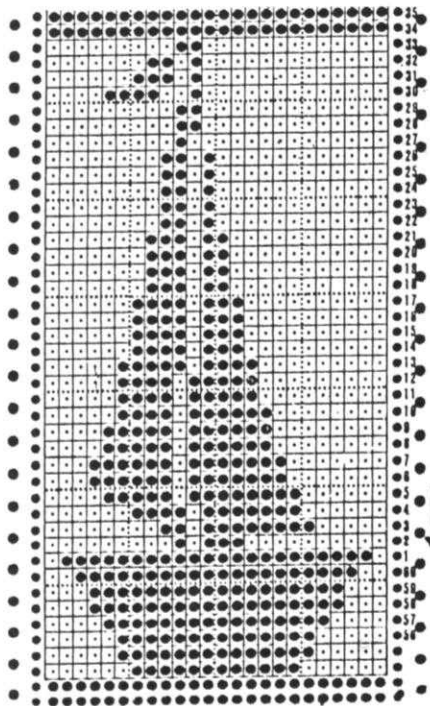

SLEEVES:

Cast on 31 (37) [43] sts. with color 1 and work 16 rows K1, P1 Ribbing.
 Transfer the ribber sts. to main machine and continue in Stockinette stitch.
WORK FULL FASHION INCREASES ON EACH SIDE. Move the 2 end sts. 1 needle out then pick up a stitch from row below and hang onto empty needle.
ON EACH SIDE, increase 1 st. every 10th row 8x.
 After Row 100 (102) [104], **SHAPE CAP:** ON EACH SIDE, bind off 4 sts. 1x, 3 sts. 1x, FULL FASHION - 1 st. every 4th row 7x, then every 2nd row 1 st. 1x, (1 st. 2x) [1 st. 2x].
 After Row 134 (138) [142], bind off the remaining sts.

FINISHING: See General Instructions.

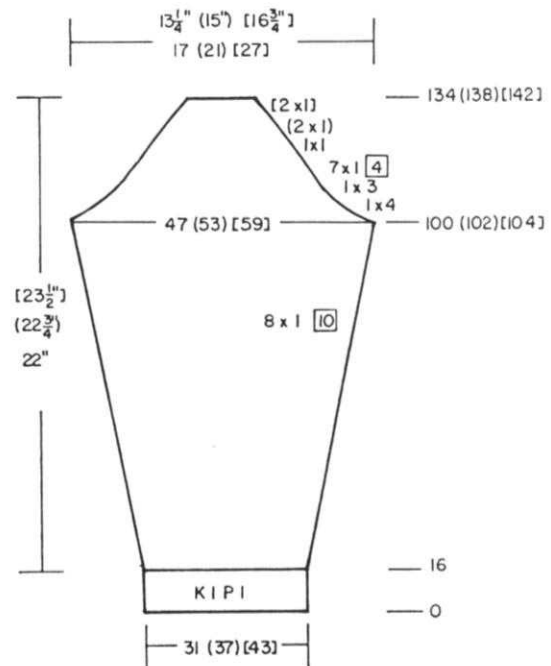

469



WOMENS STRIPED PULLOVER

SIZES: 8/10 (12/14)
YARN: Cordella
AMOUNT:
 color 1 4 balls - Black
 color 2 4 balls - White
TENSION: 8 - Ribber 4/4 I
GAUGE: 12.5 sts. 21 rows = 2" (5 cm)

Stockinette stitch with stripes.
 Bands are K1, P1 Ribbing

BACK & FRONT - The Same.

OPEN CAST ON with contrast waste yarn - 160 (172) sts.
 Knit 9 to 11 rows then 1 row with Ravel Cord to the right side.
 Counter at 0 and change to color 1.

Work **REPEATED COLOR STRIPES** of 12 (14) rows color 1
 14 rows color 2.
 After Row 56 (62), mark each side with bit of contrast yarn for setting in sleeves.
 After Row 156 (168) **TURN ROW COUNTER OFF** and knit 1 row with a Ravel Cord to the **LEFT SIDE.**
 Push in **BOTH PART BUTTONS** (machine owners other than **KNITTING** or **BROTHER**, set your controls for slip or skip) and bring Carriage across to the right side with **NO YARN.**
 Leave 39 (42) needles on the right (front) in work and leave 40 (49) needles on the **LEFT (back)** in working position. Bring the remaining needles into holding position.
 Carefully release and rip out the Ravel Cord **ON EACH SIDE** up to the needles in holding position.
 Anchor the ends of Ravel Cord so they won't get in your way. Attach color 2 and work **BACKWARDS OVER ALL NEEDLES** (you will pull out the Ravel Cord later for your neck opening).
 Turn Counter on and 14 rows color 2,
 12 (14) rows color 1.
 After Row 256 (274), mark each side for setting in sleeve.
 Continue in the color stripes to Row 312 (336) then remove the sts. onto contrast waste yarn.

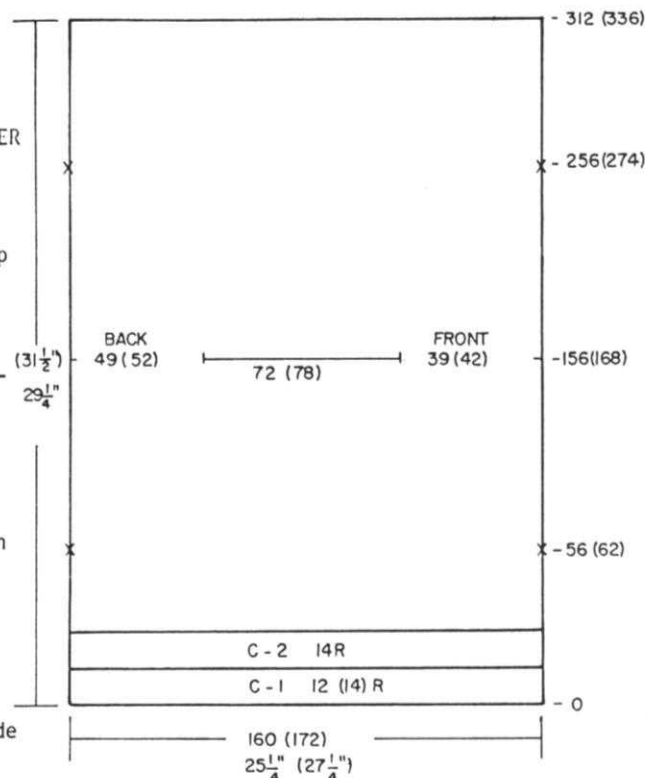

WAISTBAND: Make 2

Cast on 129 (139) sts. with color 1 and work K1, P1 Ribbing with color changes as **SHOWN ON THE CHART.**
 After Row 103, transfer the ribber sts. to main machine then pick up the sts. along one edge of waist.
 Knit 1 loose row then bind off loosely.
 Repeat for other edge of waist.

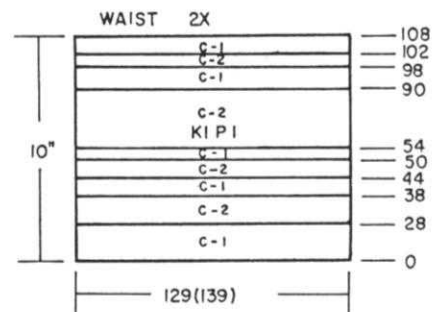

SLEEVE BANDS:

Cast on 73 (83) sts. with color 1 and work K1, P1 Ribbing with color changes as SHOWN ON THE CHART. After Row 122, transfer the ribber sts. to main machine then hang the open sts. of one edge that are held on waste yarn onto these needles, with 2 sts. on each needle except 3 sts. every 6th (14th) needle. Knit 1 loose row then bind off loosely. Repeat for second sleeve.

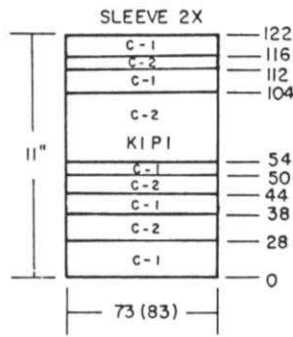

FINISHING: See General Instructions. Carefully press the neck opening sts. held on Ravel Cord. From the wrong side with color 1, work 1 row single crochet into lower half of neck opening and continue across upper half, releasing the Ravel Cord as you work the second half to be certain that the neck will be OPEN. Work 1 row slip stitch crochet around neck.

470

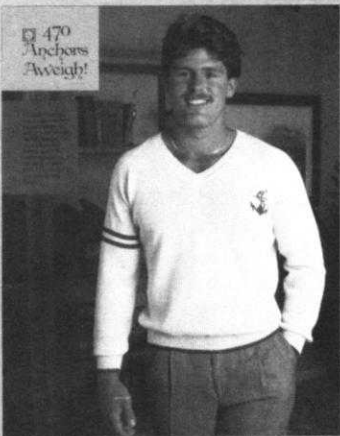

MANS PULLOVER

SIZES: 38/40 (42/44) [46]
YARN: Venetia = color 1
 Regia = color 2
AMOUNT:
 color 1 1 lb. 1 lb.4 oz. 1 1/2 lbs.
 color 2 1 ball 1 ball 1 ball
TENSION: 4.1 -Rib. 1.2/1.2 II
GAUGE: 17 sts.24 rows = 2" (5 cm)

Stockinette stitch with isolated Fair Isle Design on left Front and stripes on right Sleeve. Bands are K1, P1 Ribbing. Punch Card. (See Alternate crochet for Neckband in Finishing Instructions).

BACK:

Cast on 163 (175) [187] sts. with color 2. Work K1, P1 Ribbing. 4 Rows color 2, then continue with color 1 to Row 30. Transfer the ribber sts. to main machine and continue in Stockinette stitch with color 1. Increase 1 sts. on the right side. After Row 100, ON EACH SIDE, increase 1 st. every 30 rows 3x. After Row 188 (194) [200], SHAPE RAGLAN: ON EACH SIDE, decrease 1 st. FULL FASHION METHOD - Use 3 needle transfer tool and transfer the 3rd st. to 4th needle put the end needle out of work. Decrease 1 st. every 2nd row 59x (63x) [67x]. After Row 304 (318) [332] remove the remaining sts. onto contrast waste yarn.

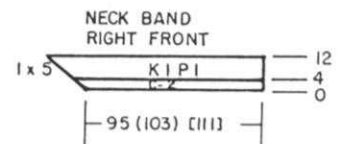
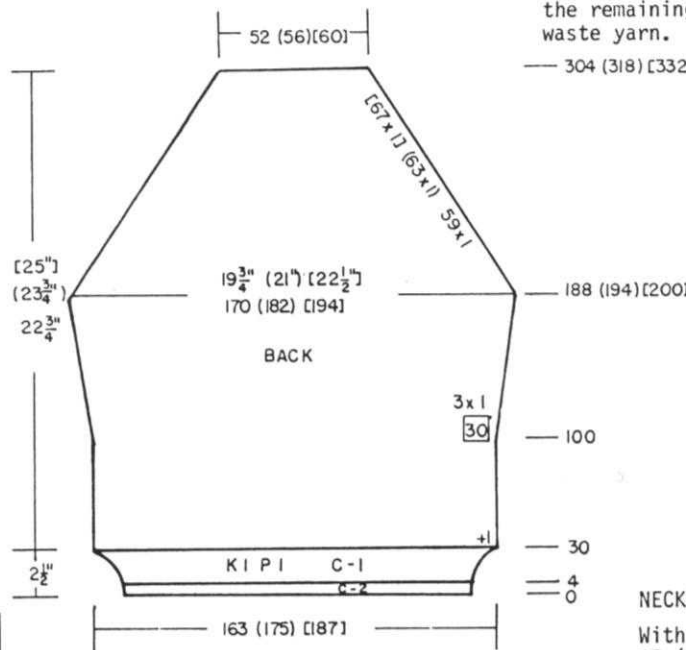
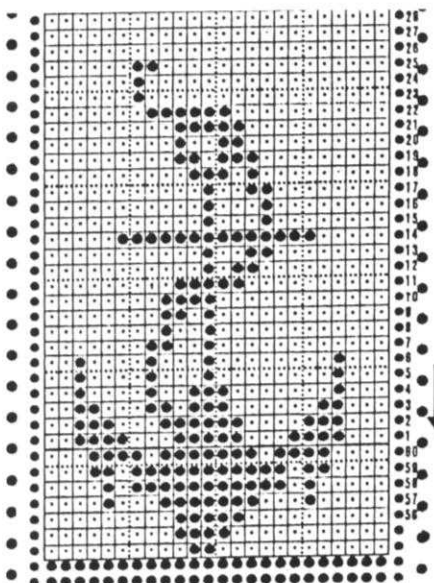

NECKBAND: Right Front.

With color 2, cast on 95 (103) [111] sts. and work K1, P1 Ribbing. 4 rows with color 1 then continue with color 1 BUT AT THE SAME TIME, ON THE LEFT EDGE, increase 1 st. every 2nd row 5x. (full fashion). After Row 12, transfer the ribber sts. to main machine and with WRONG side facing you, hang the right edge of neck onto these needles with shoulder at straight edge and center front at SHAPED edge. Knit 1 very loose row over the doubled sts. then bind off loosely.

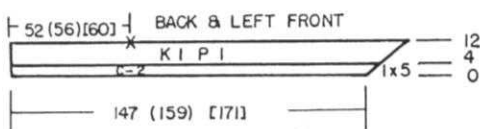

NECKBAND: Left Front and back Neck.

Cast on 147 (159) [171] sts. and work the same as front neckband but make the increases on the RIGHT side. After Row 12, transfer the ribber sts. to main machine then hang the back edge onto 52 (56) [60] needles and the remaining front onto remaining needles. Knit 1 very loose row then bind off loosely. Weave the center front of band.

FRONT:

Work the front the same as the back to Row 188 (194) [200]. SHAPE RAGLAN same as the back BUT AT THE SAME TIME, after Row 198 (204) [210], divide in the center. VERY IMPORTANT - MARK the CENTER 2 STS. ON THE LEFT HALF WITH A BIT OF CONTRAST YARN. then REMOVE ALL THE LEFT SIDE STS. ONTO CONTRAST WASTE YARN. Continue to shape the armhole and SHAPE NECK AT THE SAME TIME over the right half of front. ON NECK SIDE, decrease 1 st. every 4th row 26x (28x) [30x] After Row 304 (318) [332], bind off the remaining stitch. Hang the left half of front back onto the machine with the 2 CENTER MARKED STITCHES - 1 st. on each side of 0, then the remaining sts. on each side of these stitches. (This is to CENTER the isolated design). Knit 1 row from right to left. Turn the Row Counter back to 198 (204) [210]. ISOLATE THE DESIGN - SET PATTERN FROM LEFT TO RIGHT then continue with color 1 and color 2. AT THE SAME TIME, be sure to continue shaping raglan and neck the same as before. Work the design only 1 time then continue in Stockinette stitch with color 1. After Row 304 (318) [332], bind off the remaining stitch.

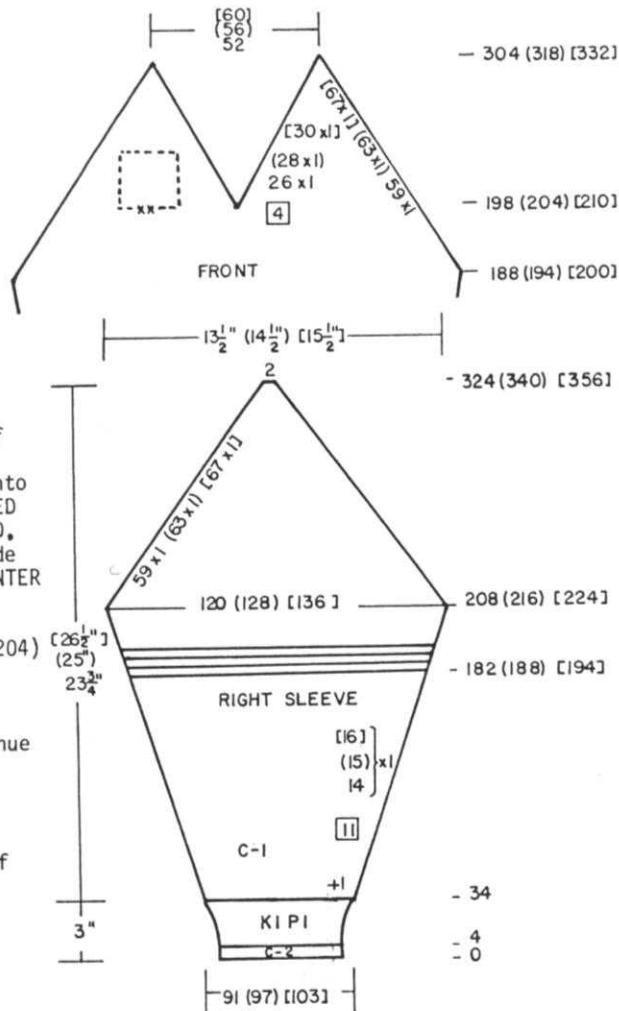

RIGHT SLEEVE

Cast on 91 (97) [103] sts. with color 2. Work K1, P1 Ribbing. Knit 4 rows with color 2, then continue with color 1 to Row 34. Transfer the ribber sts. to main machine and increase 1 st. on the right side. Continue with Stockinette st. and color 1. ON EACH SIDE, increase 1 st. every 11th row 14x (15x) [16x] BUT AT THE SAME TIME, after Row 182 (188) [194], work the color stripes of 6 rows color 2, 6 rows color 1, 6 rows color 2 then continue with color 1 After Row 208 (216) [224], SHAPE RAGLAN: ON EACH SIDE, decrease 1 st. (FULL FASHION same as front and back) every 2nd row 59x (63x) [67x]. After Row 324 (340) [356], bind off the remaining stitch.

WORK THE LEFT SLEEVE THE SAME BUT OMIT THE STRIPES.

FINISHING: See General Instructions. Work 1 row single crochet around neck edge then 3 rows double crochet (use No. 3 crochet hook), pulling in back neck by decreasing about 6 sts. across on the first double crochet row. and be sure to mitre the center front. Work 1 row single crochet to finish. Alternate neckband is given for K1, P1 Ribbing. See Chart and Instructions.

471



MENS SLEEVELESS PULLOVER

SIZES: 40/42 (44/46)
 YARN: Bravo
 AMOUNT: 11 Balls for both sizes.
 TENSION: 5.2 for Size 40/42
 6 for Size 44/46
 GAUGE: 7.5 sts. 14 rows = 5 cm (2")
 7 sts. 14 rows = 5 cm (2")
 for size 44/46

Made on the KJI 260 machine. Use the KR 230 Ribber for K1, P1 Ribbing. Punch 2 cards. The Pattern is a TUCK stitch.

BACK & FRONT the same.

Cast on 81 sts. and work 16 rows K1, P1 Ribbing, Tension 1/1. Transfer the Ribber sts. to the KH 260 machine. Knit 2 rows Stockinette st. setting PATTERN NO. 1 before knitting the 2nd row. Continue in Pattern 1 to Row 124 then mark each side with bit of yarn for putting in bands. Stop Pattern 1 after Row 153 and work 2 rows Stockinette stitch, setting Pattern 2 after Row 159. Continue in Pattern 2 to Row 204 then knit 2 rows Stockinette stitch. After Row 206, remove 19 sts. ON EACH SIDE onto waste yarn then remove the center 43 sts. onto waste yarn. Make 2nd section the same.

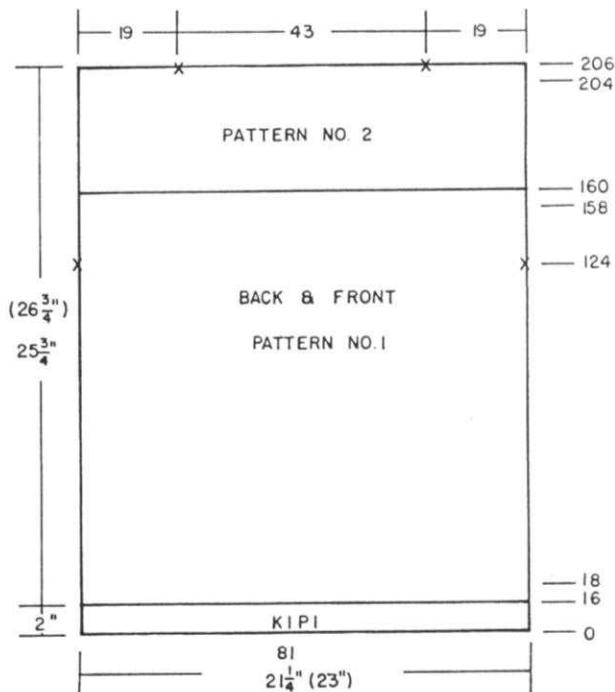

NECKBANDS: Make 2

Use KR 230 Ribber. Tension 1/1
Cast on 32 (35) sts. and work
K1, P1 Ribbing. ON EACH SIDE,
increase 1 st. every 2nd row 4x.
After Row 10, transfer the ribber
sts. to main machine then pick up
sts. on neck and bind off loosely.

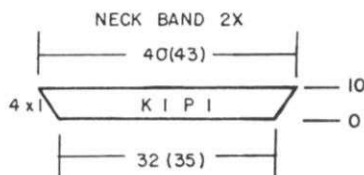

ARMHOLE BANDS:

Close shoulders first.
Use KR 230 Ribber, Tension 0.2.
Cast on 75 (81) sts. and work
12 rows K1, P1 Ribbing.
Transfer the ribber sts. to main
machine then pick up sts. along
armhole. Bind off loosely.

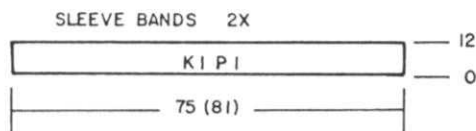

FINISHING: See General Instructions

NO. 1

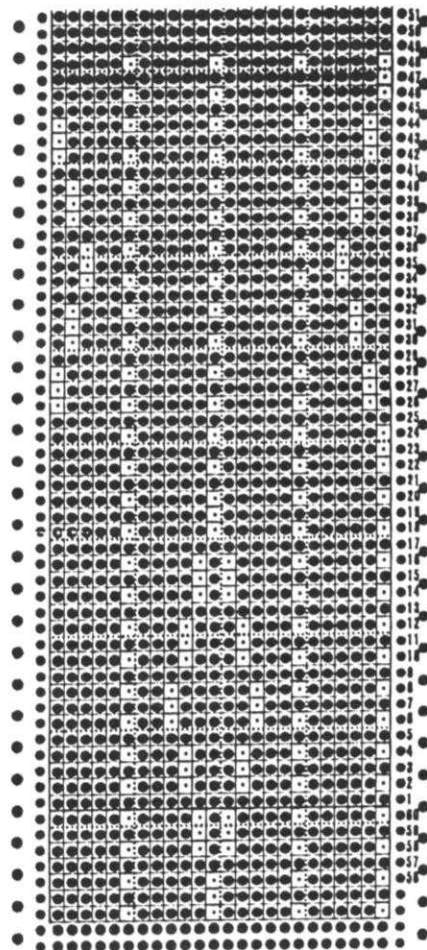

NO. 2

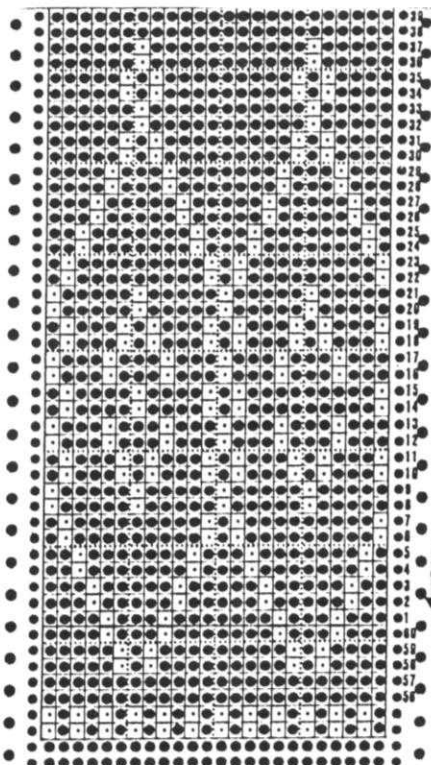

 472



WOMENS PULLOVER

SIZES: 8 to 14
YARN: Alanda
AMOUNT: 15 balls
TENSION: 4.2 - Ribber 0/0
GAUGE: 9 sts. 12 rows = 2" (5 cm)

Made on the KH 230 with KR 230
Ribber. Stockinette stitch with
Ribbed Bands. The 6 decorative
bands are ribbed separately then
sewn in place as shown on the
Chart.

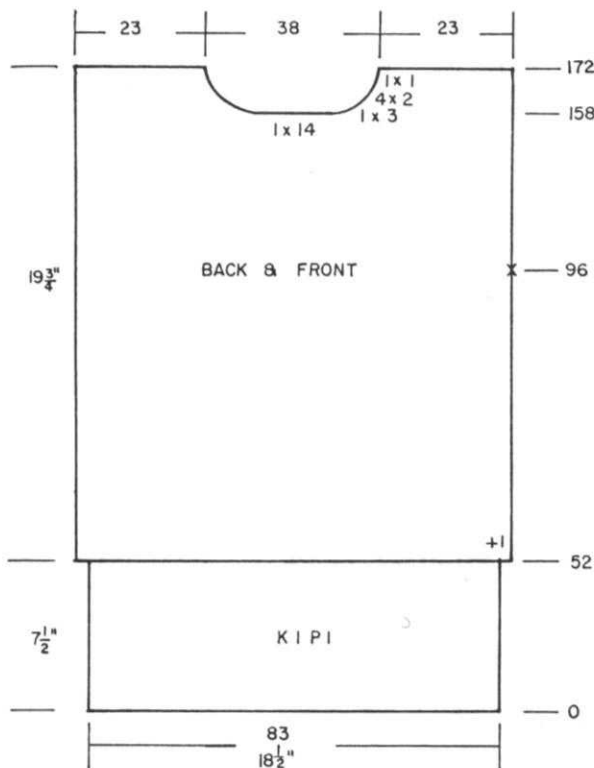

BACK & FRONT THE SAME.

Cast on 83 sts. and work 52 rows
K1, P1 Ribbing.

Transfer the ribber sts. to main
machine and increase 1 st. on the
right side.

Continue in Stockinette stitch.
After Row 96, ON EACH SIDE, mark
the edge with a bit of contrast
yarn for setting in sleeve.
Knit to Row 158.

Bind off the center 14 sts., put
the needles on the left into hold-
ing position and complete the right
side first.

*ON NECK SIDE, bind off
3 sts. 1x, 2 sts. 4x, 1 st. 1x.
After Row 172, bind off (or
remove onto waste yarn) the remaining
sts.

Bring the needles on the left into
working position, knit 1 row to
the left side, turn the Row Counter
back to 158 and complete the left
half. Follow the instructions from *.
Make second section the same.

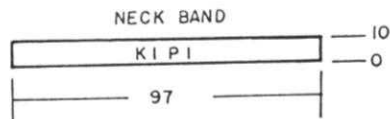

NECKBAND:

Cast on 97 sts. and work 10 rows K1, P1 Ribbing. Transfer the ribber sts. to main machine. Knit 1 row Stockinette stitch then remove the sts. onto contrast waste yarn.

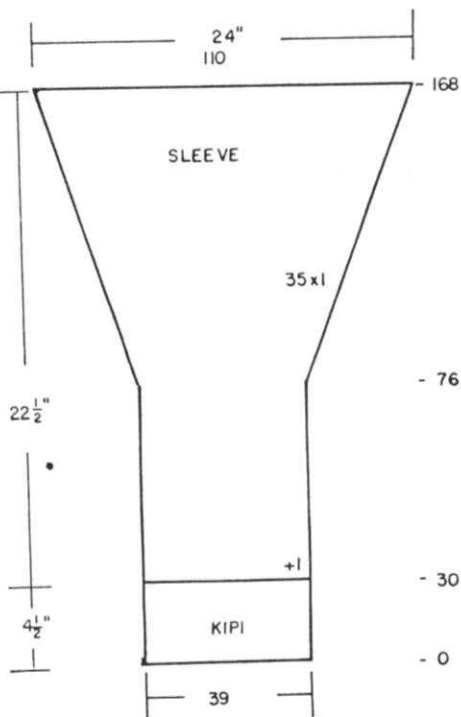

DECORATIVE FRONT BANDS: Make 6.
Cast on 19 sts. and work 130 rows K1, P1 Ribbing. Bind off.

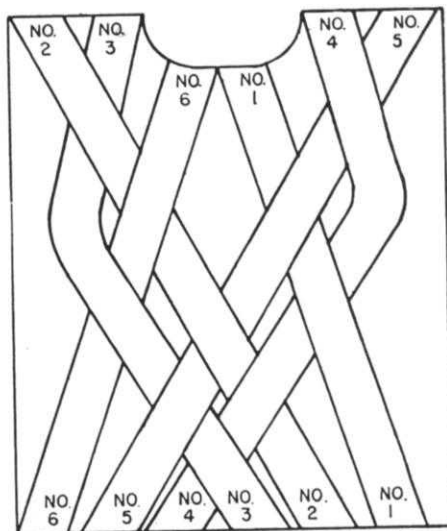

PLACEMENT FOR DECORATIVE BANDS 14

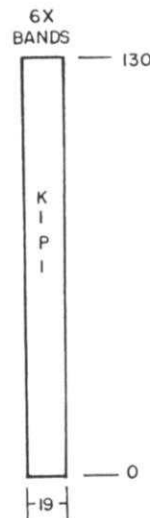

FINISHING: See General Instructions. Attach ribbed bands on front at top of Ribbing (See Chart for placement) Weave the bands as shown on the Chart and attach as shown at shoulder edge. Close shoulders and set in sleeves to marked edges. Close short edge of neckband then pin to neckline with 1/2" more of band on the front. Weave the band (or slip stitch crochet) to neckline through the open sts. Remove waste yarn.

SLEEVES:

Cast on 39 sts. and work K1, P1 Ribbing to Row 30. Transfer the ribber sts. to main machine and increase 1 st. on the right side. Continue in Stockinette stitch. After Row 76, ON EACH SIDE, increase 1 st. every 2nd row 35x. After Row 168, bind off (or remove onto contrast waste yarn) the remaining 110 sts.

GIRLS PULLOVER

SIZES: 1 year to 18 Months
YARN: Cordella
AMOUNT:
color 1 2 balls
color 2 1 ball
color 3 1 ball
TENSION: 6 Ribber 4/4 II
GAUGE: 15 sts. 20 rows = 2" (5 cm)

Fair Isle Design with bands in K1, P1 Ribbing. Punch 2 Cards.

BACK:

Cast on 91 sts. with color 1 and work 20 rows K1, P1 Ribbing. Transfer the ribber sts. to main machine and increase 1 st. on the right side. Knit 2 rows setting Pattern 1 before knitting the 2nd row. Continue in Pattern 1 with colors 1 and 2. Knit in Pattern to Row 86. SHAPE ARMHOLE and begin Pattern 2 with colors 1 and 3 after Row 88. ON EACH SIDE, bind off 4 sts. 1x, 2 sts. 1x, 1 st. 4x. When Pattern 2 is completed, continue in stockinette stitch with color 1.

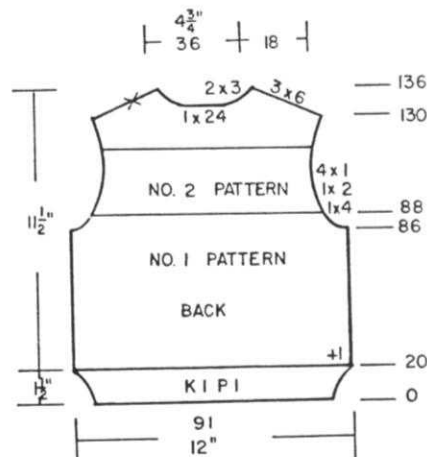

After Row 130, SHAPE SHOULDER and NECK AT THE SAME TIME. FOR NECK, bind off the center 24 sts., put the needles on the left into holding position and complete the right side first. *FOR SHOULDER, bind off 6 sts. 3x and ON NECK SIDE, bind off 3 sts. 2x. Bring the needles on the left into working position, knit 1 row to the left side, turn the Row Counter back to 130 and complete the left half. Follow the instructions from *.



473



TO GO ALONGSIDE PUNCH CARDS

PATTERN No. 1 A Feeder B Feeder
 2 Rows C-1 C-2
 4 Rows C-1

PATTERN No. 2 A Feeder B Feeder
 3 Rows C-1 C-3
 4 Rows C-1 C-3
 6 Rows C-1 C-2
 4 Rows C-1 C-2
 3 Rows C-1 C-3

FRONT:

Work the front the same as the back to Row 116. Bind off the center 10 sts., put the needles on the left into holding position and complete the right side first.

*ON NECK SIDE, bind off 3 sts. 1x, 2 sts. 3x, 1 st. 4x and SHAPE SHOULDER same as the back after Row 130.

Bring the needles on the left into working position, knit 1 row to the left side, turn the Row Counter back to 116 and complete the left half. Follow the instructions from *.

SLEEVES:

Cast on 49 sts. with color 1 and work 30 rows K1, P1 Ribbing. Transfer the ribber sts. to main machine and increase 1 st. on the right side.

Continue in Pattern 1 same as front and back and ON EACH SIDE increase 1 st. every 4th row 3x, every 6th row 8x.

After Row 96, SHAPE CAP and continue in Pattern 2 with colors 1 and 3 after Row 98.

ON EACH SIDE, bind off 4 sts. 1x, 2 sts. 2x, 1 st. 11x, 2 sts. 2x, 4 sts. 1x. Bind off the remaining sts.

NO. 1

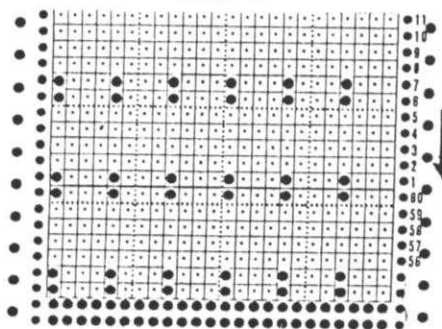

CONTINUE TO PUNCH CARD TO THE TOP OF CARD.

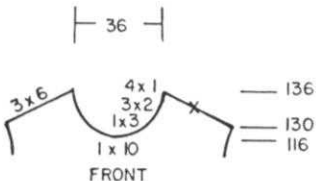

NO. 2

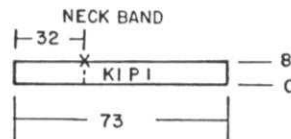
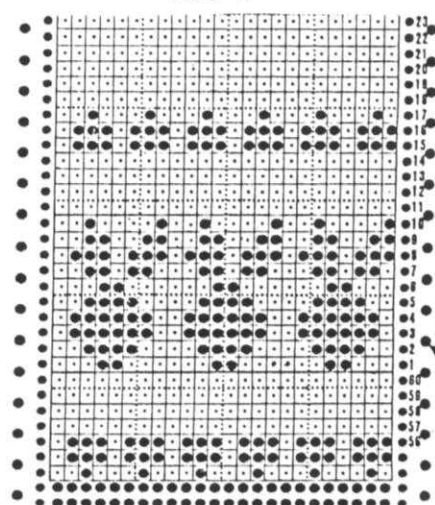

NECKBAND:

Close left shoulder first. Cast on 73 sts. with color 1 and work 8 rows K1, P1 Ribbing. Transfer the ribber sts. to main machine and with wrong side facing you, pick up 32 sts. across back neck and the remaining sts. across front neck and hang onto the machine. Knit 1 loose row then bind off loosely.

FINISHING: See General Instructions. Close right shoulder approximately 1" open at neck edge. Work single crochet across shoulder opening then make 2 loops with chain stitch for buttons. Sew buttons to back edge.

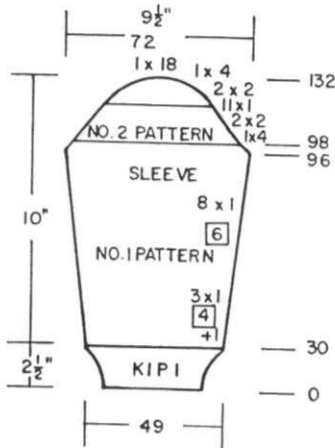

474



WOMAN'S FAIR ISLE PULLOVER

SIZES: 10/12 (14/16)

YARN: Roma

AMOUNT:

color 1 13 14 oz.
 color 2, 3, 4, 5, 6 - 1 oz.
 of each color for all sizes.

TENSION: 4 - Ribber -1/1

GAUGE: 17 sts. 23 rows = 2" (5 cm)

Made on the KH 910 COMPUKNIT machine. Draw Design on Mylar Sheet. Waist and sleeve bands K1, P1 Ribbing. Neckband is Stockinette stitch.

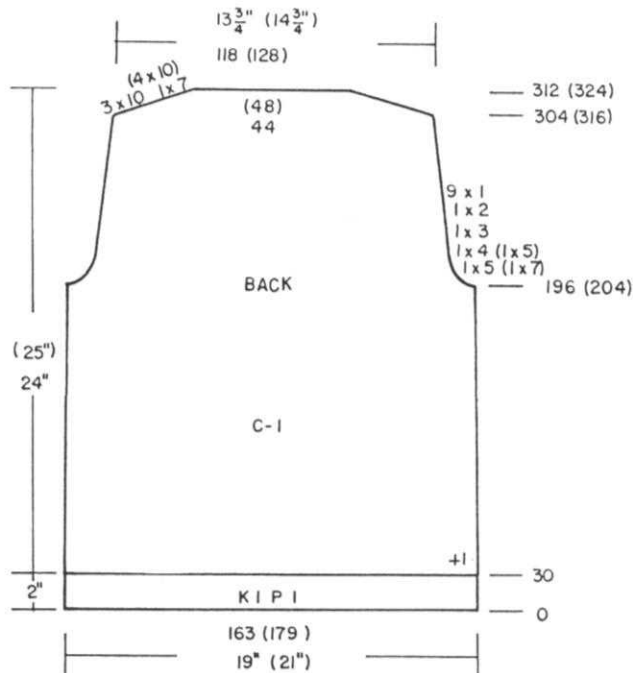

FRONT:

Work the front the same as the back EXCEPT FOR DESIGNS AND NECK SHAPING.

ALWAYS SET THE DESIGN THE ROW BEFORE THE GIVEN ROW NUMBER TO BEGIN THE DESIGN.

Work the FAIR ISLE DESIGNS AS FOLLOWS: COLOR 1 is always in A Feeder.

After Row 32 - Design No. 1 with color 2 in B Feeder (remember to SET the Design after Row 31).

Row 58 - Design No. 2 with color 3 in B Feeder.

Row 96 - Design No. 3 with color 4 in B Feeder.

Row 146 - Design No. 4 with color 5 in B Feeder, and REMEMBER TO SHAPE ARMHOLE same as back after Row 196 (204) AND AT THE SAME TIME, begin Design No. 5 with color 6 in B Feeder.

After Row 270 (278) bind off the center 14 (10) sts., put the needles on the left into holding position and complete the right side first.

*ON NECK SIDE, bind off 5 sts. 1x, 4 sts. 1x, 3 sts. 1x, 2 sts. 1x, 1 st. 1x.

After Row 304 (316) SHAPE SHOULDER SAME AS THE BACK.

Bring the needles on the left into working position, knit 1 row to the left side, turn the Row Counter back to 270 (278) and complete the left half. Follow the instructions from *.

SLEEVES:

Cast on 85 (97) sts. with color 1 and work 30 rows K1, P1 Ribbing. Transfer the ribber sts. to main machine and increase 1 st. on the right side.

ON EACH SIDE, increase 1 st. every 10th row 19x.

After Row 226 (230) SHAPE ARMHOLE and begin Design No. 6 after Row 236 (240) Remember to set Design the row before)

FOR ARMHOLE, ON EACH SIDE, bind off 5 (7) sts. 1x,

4 (5) sts. 1x, 1 st. every 5th row 16x then 1 st. every 2nd row 13x.

After Row 340 (346), bind off the remaining sts.

NECKBAND:

Cast on 124 (138) sts. with color 1 and work 20 rows Stockinette stitch. Hang the hem. Close 1 shoulder first, then pick up 40 (46) sts. across the back neck (wrong side facing you) then pick up 84 (92) sts. across the front neck. Knit 1 loose row then bind off the crochet method loosely.

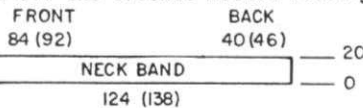

FINISHING: See General Instructions.

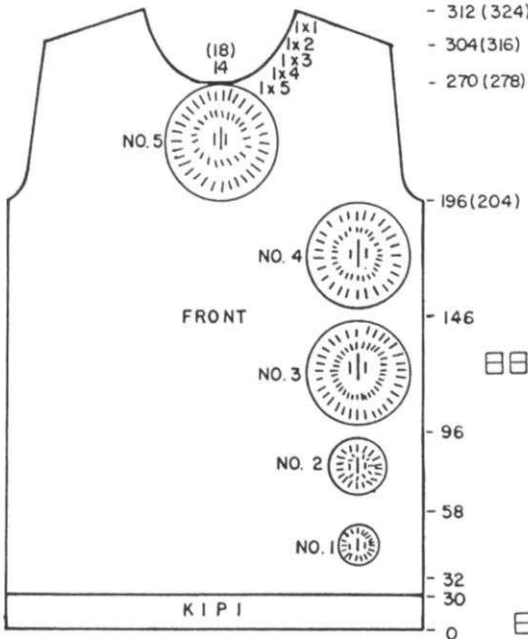

BACK:

Cast on 163 (179) sts. with color 1 and work 30 rows K1, P1 Ribbing. Transfer the ribber sts. to main machine and increase 1 st. on the right side.

Continue in Stockinette stitch. Knit to Row 196 (204).

SHAPE ARMHOLE: ON EACH SIDE, bind off

5 (7) sts. 1x, 4 (5) sts. 1x, 3 sts. 1x, 2 sts. 1x, 1 st. 9x. Knit to Row 304 (316).

SHAPE SHOULDERS: ON EACH SIDE, bind off

10 sts. 3x, 7 sts. 1x. (10 sts. 4x)

After Row 312 (324), bind off the remaining sts. or remove them onto contrast waste yarn.

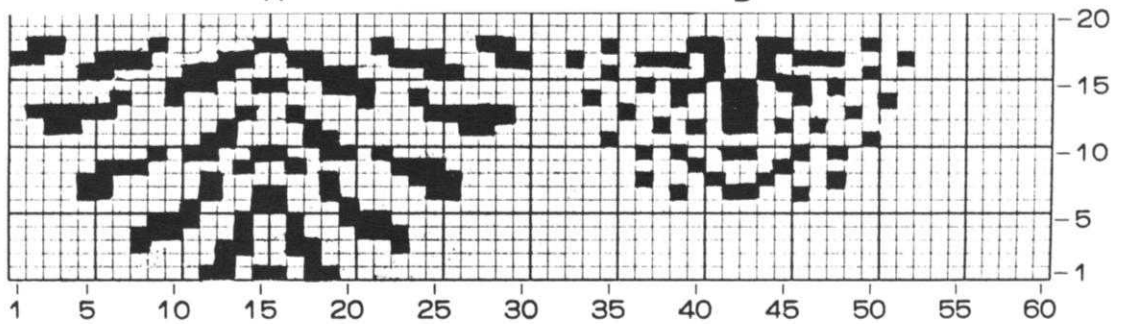
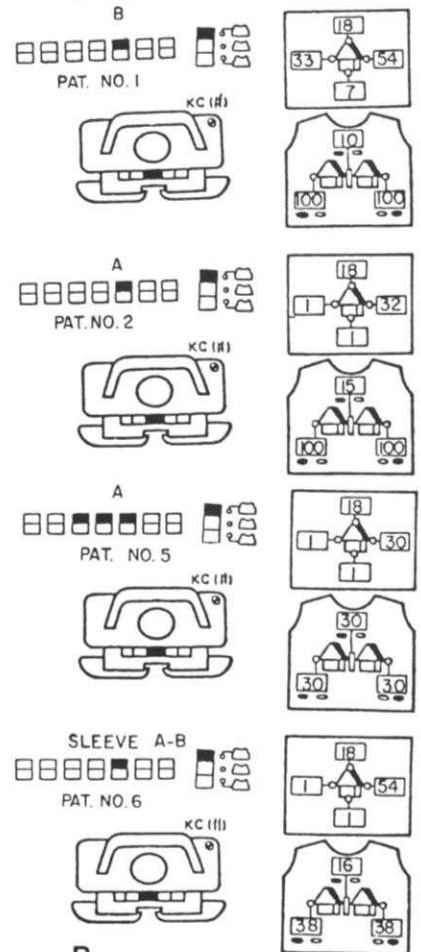
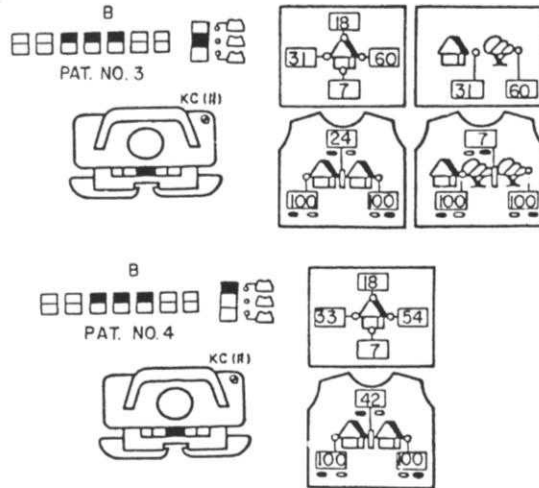
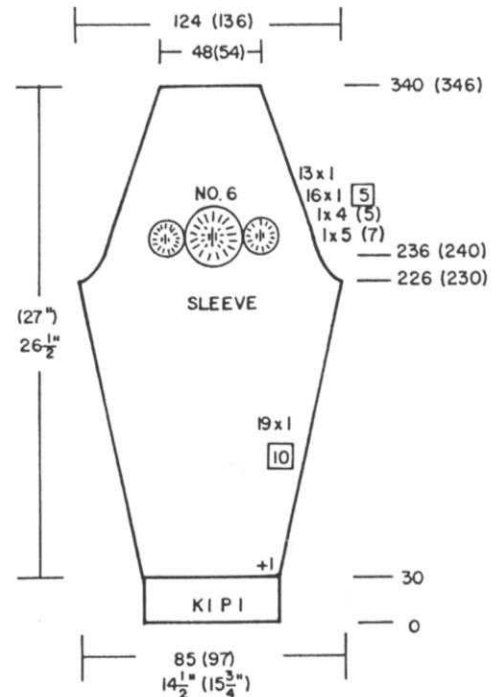



WOMANS SLEEVELESS PULLOVER

SIZES: 4/6 (8/10) [12/14]

YARN: Marisa - 100% Cotton

AMOUNT:

color 1 3/4 lb. 1 lb. 1 lb.

color 2 2 oz. 2 oz. 2 oz.

TENSION: Intarsia Carriage - 3.2 to 4

Regular Carriage - 4 to 4.1

Ribber - 0/0 II

GAUGE: 17 sts. 24 rows = 2" (5 cm)

Stockinette stitch combined with Intarsia (or Short Row) for design. Neck & Sleeve bands FULL NEEDLE RIB, Waistband K1, P1 Ribbing.

BACK:

With color 1, cast on 155 (167) [179] sts. and work 30 rows K1, P1 Ribbing.

Transfer the ribber sts. to main machine and continue in Stockinette stitch.

Knit to Row 124 (130) [136]. **SHAPE UNDERARM:** ON EACH SIDE, increase 1 st. every 2nd row 10x.

Knit even to Row 226 (238) [250]. **SHAPE SHOULDER AND WATCH FOR NECK SHAPING.**

FOR SHOULDER, bind off 7 sts. 8x (8 sts. 2x, 7 sts. 6x) [8 sts. 4x, 7 sts. 4x]

BUT AT THE SAME TIME, after Row 236 (248) [260], bind off the center 54 (62) [70] sts., put the needles on the left into holding position and complete the right side first.

***ON NECK SIDE,** bind off 2 sts. 2x, 1 st. 1x.

Bring the needles on the left into working position, knit 1 row to the left side, turn the Row Counter back to 236 (248) [260] and complete the left half. Follow the instructions from * and don't forget to complete the shoulder shaping.

FRONT:

With color 1, cast on 155 (167) [179] sts. and work 30 rows K1, P1 Ribbing.

Transfer the ribber sts. to main machine and continue in stockinette stitch with INTARSIA (or you can use SHORT ROWS) following the Line Drawings No. 1, No. 2, No. 3 with the color changes as shown. **AT THE SAME TIME,** after Row 124 (130) [136], work the increases ON EACH SIDE for sleeve shaping same as you did for the back.

Continuing in Design SHAPE NECK after Row 216 (228) [240]. Bind off the center 16 (20) [24] sts. and put the needles on the left into holding position and complete the right side first.

***ON NECK SIDE,** bind off 6 sts. 1x, 5 sts. 1x, 4 sts. 1x, 2 sts. 2x (3x) [4x], 1st. 5x **AND AT THE SAME TIME,** after Row 226 (238) [250], **SHAPE SHOULDER.**

DIVIDE THE FIRST SHOULDER STS.

OF COLOR 1. into 3 sections - and bind them off within 6 rows and while continuing the Design, make the remaining bind offs for shoulder as shown on the Line Drawing No. 3.

Bring the needles on the left into working position and complete the left half, following the instructions from *.

NECK BAND

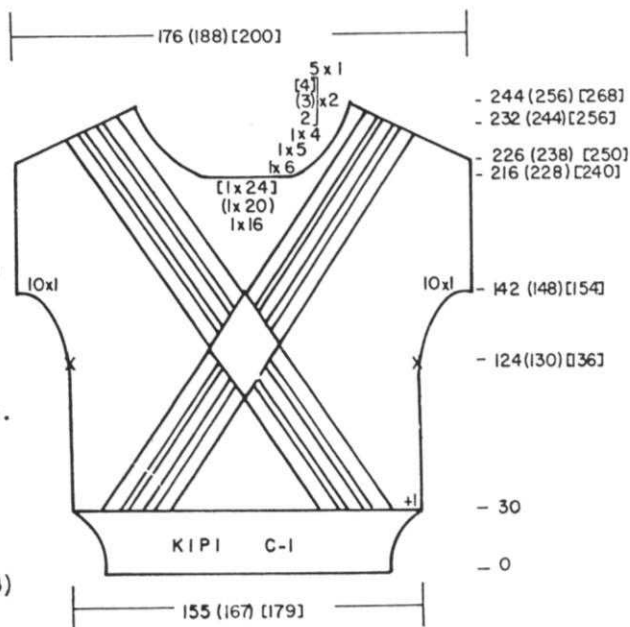
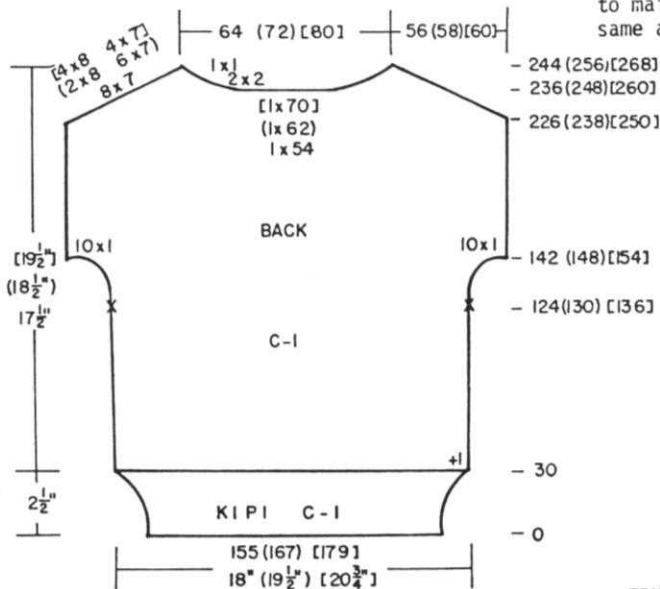
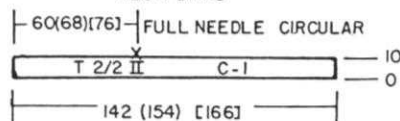

NECKBAND: Make neckband before sleeve bands. Close right shoulder first.

Cast on 142 (154) [166] sts. with color 1 and work FULL NEEDLE CIRCULAR RIBBING TO ROW 10, Tension 2/2 II. Transfer the ribber sts. to main machine (double sts. will be on each needle). Knit 1 row over the doubled sts. then hang the neck with wrong side facing you picking up 60 (68) [76] sts. across back neck and divide the remaining evenly across front. Bind off the doubled sts. loosely using the crochet method with yarn held around the gate pegs.

ARMBANDS: Make 2

Both shoulders must be closed. Cast on 96 (104) [112] sts. with color 1 and work FULL NEEDLE RIBBING for 10 rows same as you did for the NECKBAND. Transfer the ribber sts. to main machine and complete the same as you did for the neckband.

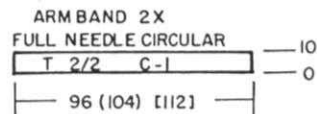

FINISHING: See General Instructions.

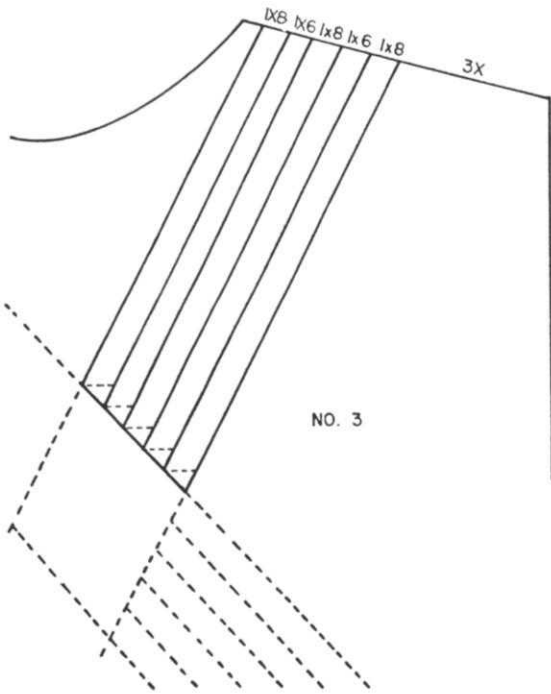
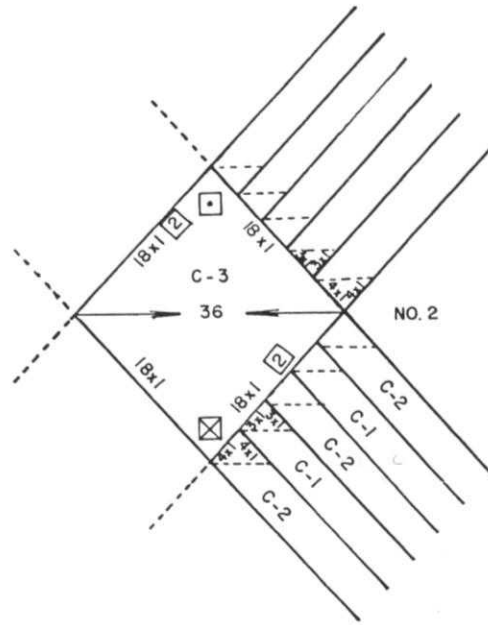
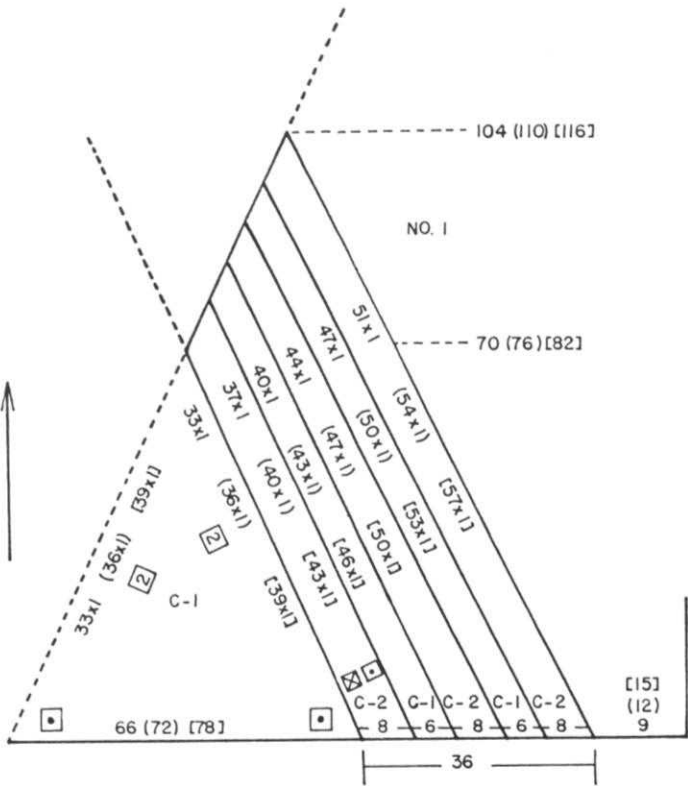

KNITKING introduces

The Twister

A two-way Winder.

Twist your way to multi-color garments... Create your own original yarns by twisting your own selection of colors and textures. It will also wind a single strand of yarn into a ball.

with Twister **without Twister**

PRICE: \$27.95—California residents add Sales Tax.
SHIPPING costs—\$2.50

Order direct from your dealer or from:
KNITKING, 1128 Crenshaw Blvd., Los Angeles, Calif. 90019



476



WOMENS LARGE SIZE DRESS

SIZES: 42/44
YARN: Venetia
AMOUNT:
 color 1 1 lb. 11 oz.
 color 2 3 oz.
TENSION: 5
GAUGE: 16 sts. 23 rows = 2" (5 cm)

Stockinette stitch with ISOLATED Fair Isle Design on Front and one Sleeve. Made on the KH 910 but can be knitted on any Electronic machine. Bands are Stockinette stitch.

NOTE: On every 100 rows, mark each side with a bit of contrast yarn to make it easy for you to put together.

BACK:

Cast on 200 sts. with color 1. You can use cast on comb method if you like. With 1 tension LOWER than garment tension, knit 16 rows. Change to garment tension and knit to Row 32. HANG HEM, and knit doubled sts. together with 1 tension LARGER than garment tension. Change to garment tension and continue in Stockinette.
 After Row 380, ON EACH SIDE, bind off 6 sts. then work FULL FASHION DECREASES using a triple transfer tool and placing the 3rd st. on 4th needle. Put empty needle out of work. Decrease 1 st. every 2nd row 27x then 1 st. every 3rd row 26x.
 After Row 512, bind off the remaining sts.

FRONT:

The front is made the same as the back to Row 100.
 ISOLATE THE DESIGN as shown on the Mylar Chart, working PATTERN A to Row 250. Knit 2 rows Stockinette stitch with color 1 then work PATTERN B as shown on the Mylar Chart. Continue in Stockinette stitch. After Row 380, ON EACH SIDE, bind off 6 sts. then work FULL FASHION DECREASES same as you did for the back. ON EACH SIDE, decrease 1 st. every 2nd row 17x, then 1 st. every 3rd row 22x BUT AT THE SAME TIME, after Row 466, bind off the center 52 sts., put the needles on the left into holding position and complete the right side first.
 *ON NECK SIDE, bind off 7 sts. 2x, 5 sts. 1x, 3 sts. 1x, 2 sts. 1x, 1 st. 2x being sure to continue the raglan shaping. Bring the needles on the left into working position, knit 1 row to left side, turn the Row Counter back to 466 and complete the left half. Follow the instructions from *

LEFT SLEEVE:

Cast on 142 sts. with contrast waste yarn. Knit 9 to 11 rows then 1 row with ravel cord to the right side. Change to Garment yarn and put Counter at 0.
 ON EACH SIDE, increase 1 st. every 8th row 12x BUT AT THE SAME TIME, after Row 44, WORK PATTERN B as shown on the Mylar Chart. AT THE SAME TIME, after Row 100, ON EACH SIDE, bind off 6 sts. then continue with the FULL FASHION DECREASING FOR FRONT AND BACK SIDES OF SLEEVE AS SHOWN ON THE CHART. After Row 186, bind off 19 sts. to the RIGHT of 0, put the needles on the left into holding position and complete the right side first.

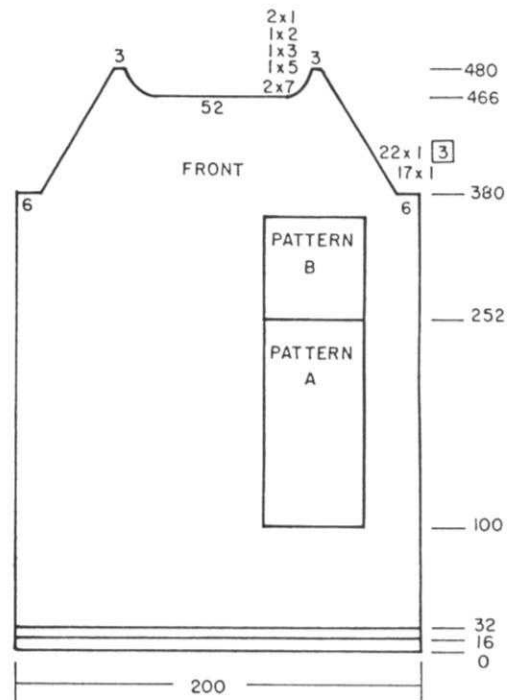

Work the NECK shaping as shown on the Chart and continue the raglan shaping. After Row 200, bind off the remaining sts. Bring the needles on the left into working position, knit 1 row to the left side, turn the Row Counter back to 186. Continue the raglan shaping and neck shaping as shown on the Chart. After Row 232, bind off the remaining sts.

Work the RIGHT SLEEVE with REVERSE SHAPING, BUT OMIT THE DESIGN and follow the Chart for the LEFT SLEEVE.

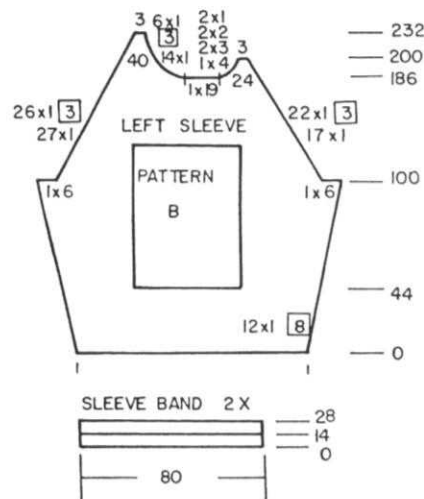

SLEEVE BANDS - Make 2

Use OPEN CAST ON with waste yarn or you can use cast on comb.
 Cast on 80 sts. and work Stockinette stitch. 14 rows with Tension 4, 14 rows with Tension 3.
 Hang hem. With wrong side facing you, hang the open sts. of sleeve onto these needles, 1 st. on first 9 needles and 2 sts. across until last 9 needles where you will hang 1 st.
 Knit 1 LOOSE row then bind off loosely.

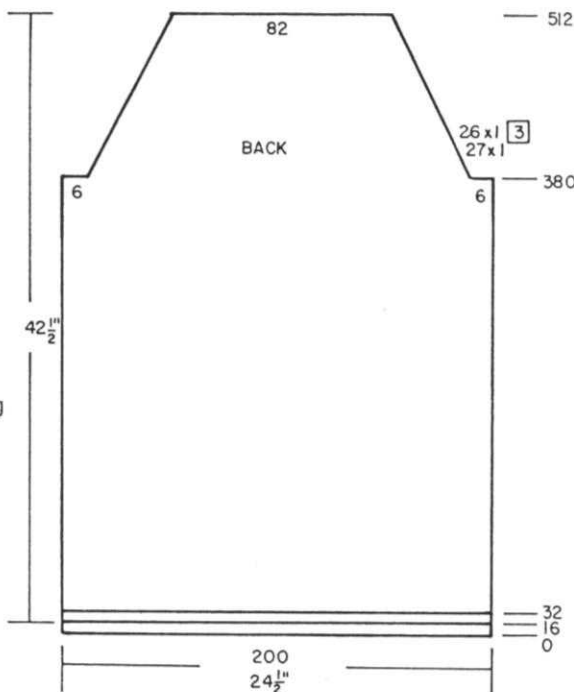

NECK BANDS: Sew in sleeves first.

FRONT: Cast on 137 sts. with waste yarn SAME AS YOU DID FOR SLEEVE BANDS.

Knit Stockinette stitch the same as you did for the sleeve bands, changing tensions as before.

Hang the hem. Pick up the sts. as shown on the Chart, knit 1 loose row then bind off loosely.

BACK Cast on 106 sts. and work the same as front neckband.

FINISHING: See General Instructions. Thread elastic through casing at neckline. Approximately 30" of fine elastic depending on desired drape at neck.

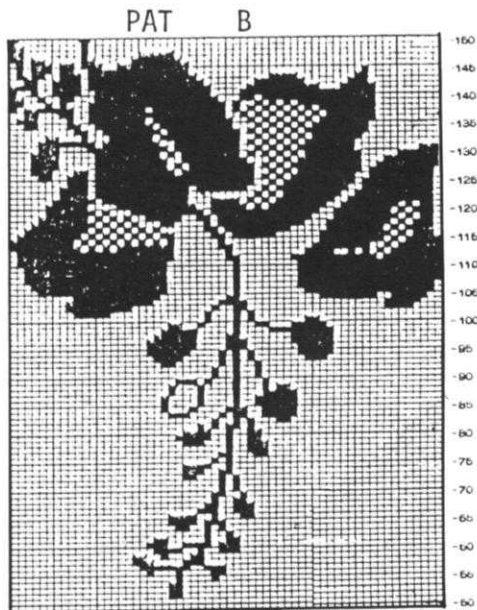
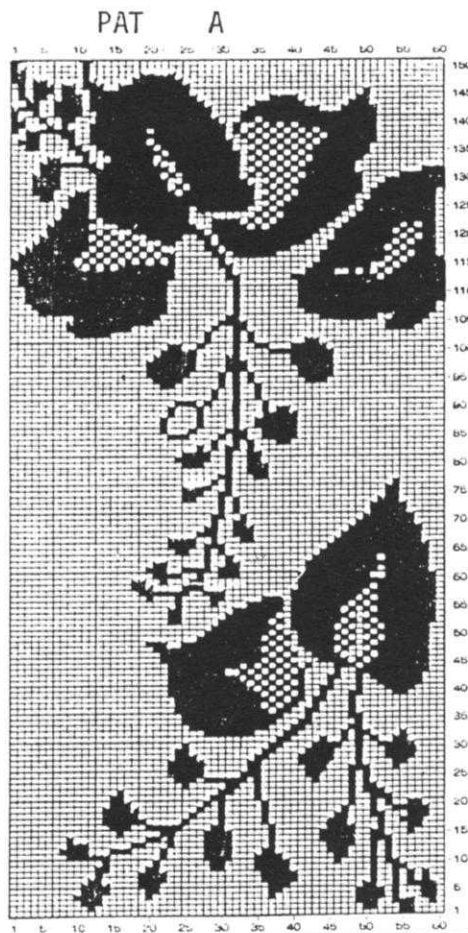
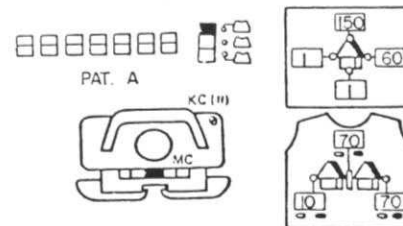
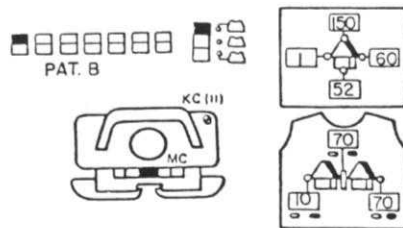
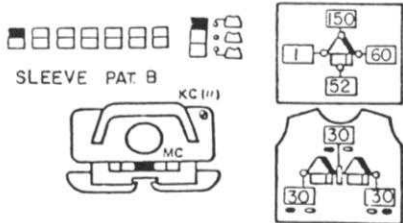
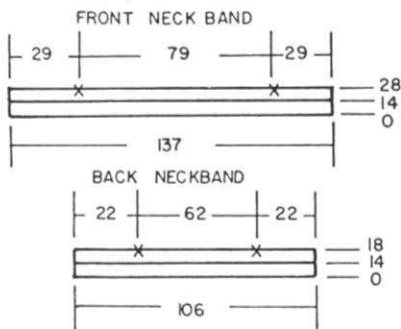

INTARSIA CARRIAGE KA 2600 (ready end of October, 1985)

The new KA 2600 INTARSIA CARRIAGE is made only for the KH 260 Punch Card Bulky knitter. With it, you can knit large pictures, argyle designs or random blocks of different textures in as many colors as you wish without strands of yarn (floats) carried over the purl side of your knitting. When knitting Intarsia designs, the Intarsia Carriage replaces the main carriage of your knitter. It has a tension control dial to match the dial on your machine and it comes complete with a detailed instruction manual in English, Spanish, German, French and Italian.

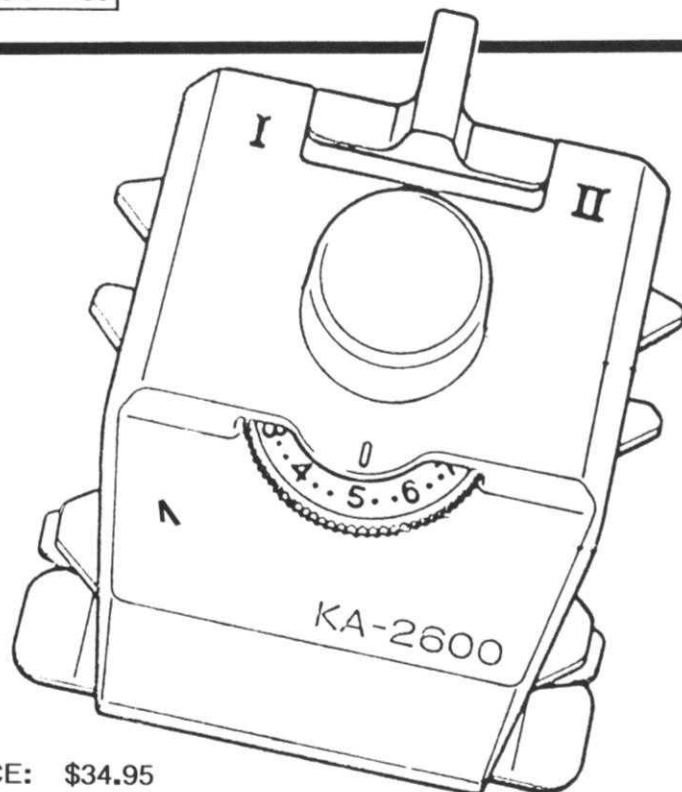

Order from your local dealer or direct from:
KNITTING, 1128 Crenshaw Blvd., L.A.CA 90016

PRICE: \$34.95
(plus \$2.50 shipping costs)



KATYS COUSIN KLARA

SIZE: Approximately 19" to 20" from top of head to toes.
YARN: Alanda (Wax the yarn) for doll. Amore for clothing
AMOUNT: Alanda - flesh color - 3 balls Amore - color 1 Blue - 2 balls Small amounts of Amore for colors 2, 3, 4, 5 NOT INCLUDED IN KIT.
 4-ply worsted - 2 oz. for hair - not included in Kit. Brown or Yellow.
AMORE COLORS ARE: color 1, blue; color 2, white; color 3, green; color 4, Red; color 5, Black.
TENSION: 7 for Doll = 14 sts. 21 rows = 2" (5 cm).
 TENSION 5 for clothing = 17 sts. 21 rows = 2" (5 cm)
 Stockinette stitch with Fair Isle Border Design on Skirt and Sleeves. Holding position for picot on hem of Skirt and Sleeves.

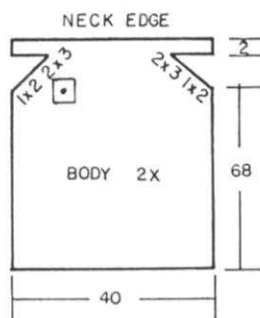

BODY: Make 2 sections.

'e' cast on 40 sts. with flesh color same way as you did for head. Work Stockinette stitch to Row 68.
SHAPE SHOULDERS: Work SHORT ROWS: Put into holding position same way as you did for the head - 2 sts. then 3 sts. 2x ON EACH SIDE. Bring all needles OPPOSITE CARRIAGE into working position before knitting the next 2 rows. Bind off.

HEAD:

Cast on 44 sts. with contrast waste yarn. Knit 7 to 9 rows. 1 Row Ravel Cord.
 With flesh color yarn, 'e' cast on over the ravel cord. Counter at 0. Knit 6 rows.
WORK SHORT ROWS:
 ON OPPOSITE SIDE OF CARRIAGE, put into holding position 9 sts. before knitting the next 2 rows. (Be sure to always wrap the inside needle to prevent a hole).
 ON OPPOSITE SIDE OF CARRIAGE, ALTERNATELY bring back 1 needle then 2 needles until all are in work.
 Knit 26 rows.
WORK SHORT ROWS EACH SIDE - bring into holding position ALTERNATELY 1 needle then 2 needles each side till 9 are in holding on each side. Alternately, bring back 1 needle then 2 needles till all are in work.
 Knit 26 rows.
WORK SHORT ROWS EACH SIDE. Bring into holding position ALTERNATELY 1 needle then 2 needles till 9 are in holding on each side. Bring all the needles into working position opposite carriage before knitting the next 2 rows. Knit 6 rows then bind off.

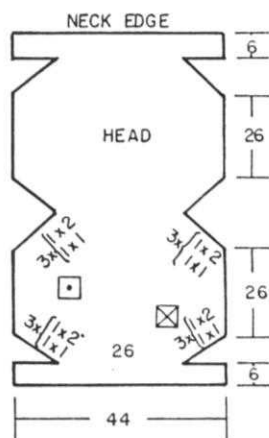

ARMS: Make 1, reverse 1.

'e' cast on with flesh color 36 sts. Knit to Row 50. Remove 18 sts. on the left (right for second arm) onto contrast waste yarn. Put the next 13 sts. into holding position. Over the remaining 5 needles, knit 2 rows, then work SHORT ROWS following the Chart for the thumb. Remove the sts. onto waste yarn. Bring the 13 sts. onto working position. Knit 6 rows. **WORK SHORT ROWS** as shown on the Chart for the HAND. When short rows are completed, knit 6 rows. Remove the sts. onto contrast waste yarn. Fold over the 18 sts. held on waste yarn and weave the 5 sts. of thumb to 5 edge sts. then weave the 13 sts. of hand to the remaining sts. at wrist. Sew all seams leaving end open. Stuff firmly with fibre fill Polyester. Close top of arm. Reverse 2nd arm.

LEGS: Make 1, reverse 1.

With flesh color, 'e' cast on same way as before. Knit to Row 76. Remove 20 sts. on the left (right for 2nd leg) onto waste yarn. **WORK SHORT ROWS** same way as you did before - following the Chart. When all needles are back in work, knit 6 rows. Remove onto waste yarn. Weave the open sts. of foot to the open sts. of leg. Sew seams then stuff with Polyester. Close top of leg. Reverse shaping for second leg.

HAIR: EVERY OTHER NEEDLE

With brown knitting worsted, cast on 60 sts. over every other needle. Tension 4 or 5 (needs to be firm knitting). Knit 60 rows. Steam piece and allow to dry overnight.

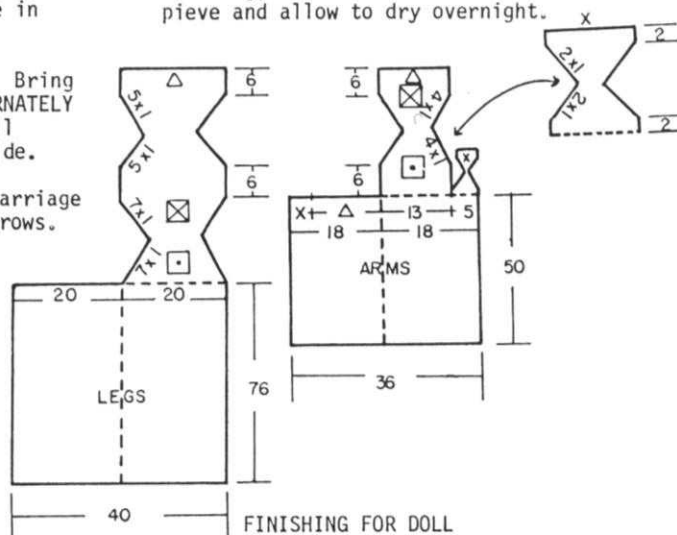

FINISHING FOR DOLL

Sew or weave head seams, leaving neck edge open. Stuff firmly, then close neck. Sew or weave seams of body leaving neck edge open. Sew arms and legs to body. If you know how to work soft sculpter, work the nose 3/4" down from top of stuffed head and the mouth 3/4" from lower edge of nose. Put in dimples on each side of mouth. Embroider eyes making them approximately 5/8" in diameter and place them so that the inner edge is 1/2" from nose (SEE PICTURE). Sculpt the fingers and toes. Make dimples on knees in center of legs approximately 4" down from top of leg for outer dimple and 3 1/2" down for inner dimple. Unravel knitting worsted hair as you loosely wrap the hair around a 1 1/2" cardboard. Sew along 1 long edge with yarn then remove from cardboard. You will need 3 pieces. One to go around face, the other two to fill in over and around head. Sew in place here and there with doubled matching thread. Arrange curl to please you then spray lightly with hair spray and allow to dry. Dust powder rough on cheeks and chin and also on knees. If you do not know how to work soft sculpture, it is OK just to embroider the face (see picture).

CLOTHING: - Amore Yarn.

DRESS: SKIRT - With color 1, 'e' cast on 200 sts. (Use cast-on-comb method if you like). TENSION 4.1, knit 4 rows. TENSION 7 Bring every 2nd needle into holding position and with color 2 Knit 2 rows. Release Holding Cam. TENSION 4.2. All needles in working position and with color 1, knit 4 rows. TENSION 6 - Hang hem and knit 1 row. TENSION 5 for remainder of skirt. With color 1, knit 3 rows, setting Pattern before knitting 3rd row. Work 6 rows Fair Isle with colors 1 and 3.

4 rows color 1 and 4. Continue in Stockinette stitch with color 1. After Row 64, remove the sts. SEPARATELY - 50 sts. on the right, 50 sts. on the left and 100 in the middle using contrast waste yarn (use different colors to make it easy to pick up later).

DRESS BODICE:

With wrong side facing you, hang the skirt sts. onto the machine DOUBLING the sts. across (see Chart). With color 1, work Stockinette stitch. Knit 8 rows.

Leave 19 sts. in working position on the right side. Put the remaining sts. into holding position and complete the right back first. Knit to Row 38. Remove 12 sts. on the right onto waste yarn (or bind them off) then knit 2 rows over the remaining 7 sts. Remove onto waste yarn.

Turn the Row Counter back to 8 and work the left back with reverse shaping. Bring the remaining sts. for front into working position. Turn Row Counter to 8. Bind off 8 sts. beginning next 2 rows. Knit to Row 30. Bind off the center 20 sts. put the needles on the left into holding position and complete the right side first.

*ON NECK SIDE, bind off 3 sts. 1x, 2 sts. 1x, 1 st. 1x. After Row 40, bind off the remaining sts.

Bring the left side needles into working position, Counter at 30 and complete the left half. Follow the instructions from *.

With RIGHT SIDE facing you, hang the 7 sts. of back shoulder onto machine in back of the latches then with wrong side facing you, hang the 7 sts. of front in the hooks of the needles. Pull front sts. through the back sts. then bind off.

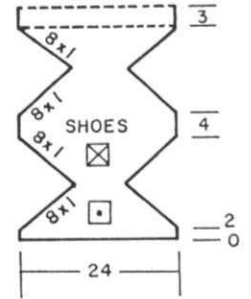
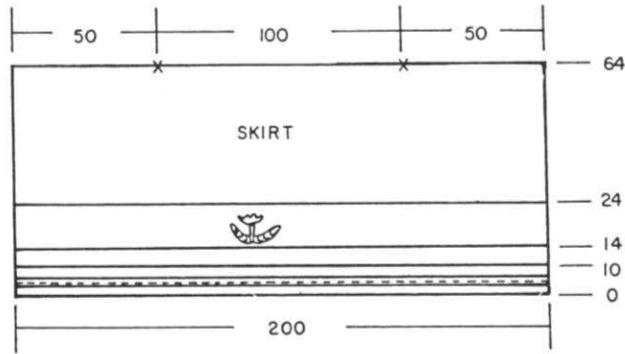

SLEEVES:

'e' cast on with color 1 same method as for skirt. Work the first 24 rows same as for Skirt (see picture). Continue with stockinette stitch and color 1 to Row 48. Mark each side with bit of yarn for setting sleeves into armhole. Knit to Row 54 then bind off.

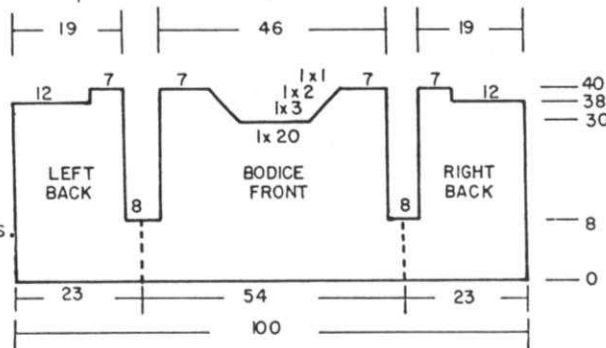
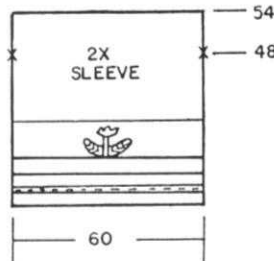

PANTS: Make 2 sections.

'e' cast on with color 1 = 94 sts, same way as you did before. Work the first 10 rows the same as you did for Skirt. After hanging the hem, continue in Stockinette stitch with color 1. Knit to Row 32. ON EACH SIDE, bind off 4 sts. 1x, 3 sts. 1x, 2 sts, 1x then 1 st. every 2nd row 6x. After Row 66. mark the next row by knitting 1 row over every other needle. Knit to Row 74, pick up the sts. from marked row (hem) then bind off. Close leg seams then crotch seams. Thread narrow elastic through at waist and leg hems (cut elastic to fit waist and legs of doll).

SHOES:

With color 5 (black), cast on 24 sts. using the closed or e cast on method. Knit 2 rows then work SHORT ROWS. Put into holding position, 1 st. 8x ON EACH SIDE. Bring back 1 needle until all are in work. Knit 4 rows. REPEAT THE SAME SHORT ROWS. Transfer every other st. to next needle. Leave empty needles in work. Knit 3 rows. Bind off 2 sts. together tightly.

Work single crochet around shoe except on side edges, work double crochet (about 4 sts.). Put shoe on doll and with doubled yarn, make chain to fit across ankle (about 19 or 20 chains). Sew to each side of shoe to fit rather snugly. Purchase newborn stretch socks with lace trim.

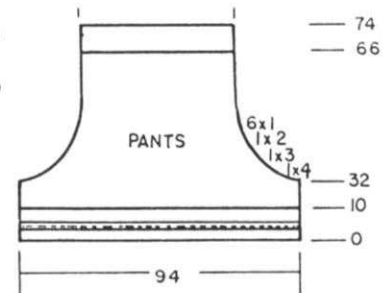

FINISHING:

Close seams of sleeves then set into armhole, adjusting to fit with marked edge of sleeve to fit space at underarm. Thread elastic through sleeve hem. Close skirt to about 1 inch below waist then work single crochet around opening for 2 rows. Fold right edge to the inside. Work 1 row single crochet around neckline then with white work single crochet then chain 2, slip st. into first chain, skip 1 st. on neck single crochet into next stitch and repeat around. Sew small pieces of velcro or sew snaps onto opening.

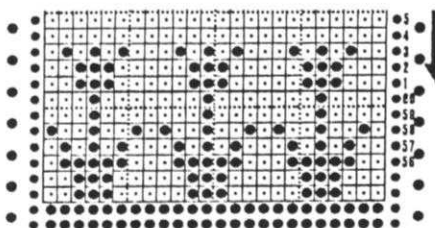



BABY ROMPER

SIZE: Newborn to 6 Months
 YARN: Amore
 AMOUNT: 2 balls
 TENSION: 5 - Mock Rib, Ten, 4
 GAUGE: 16 sts. 26 rows = 2" (5 cm)

Stockinette stitch with isolated Lace Design on the front section. See your own Instruction Manual for punching Lace Cards and isolating designs for machines other than KNITKING and BROTHER. Neck, Sleeve and Leg bands are Mock Ribbing. Punch Card.

BACK:

OPEN CAST ON 22 sts. with waste yarn. Knit 9 to 11 rows then 1 row with ravel cord to the right.

Counter at 0, and change to garment yarn. Stockinette st. After Row 8, ON EACH SIDE, increase 1 st. (FULL FASHION) every 2nd row 27x.

Knit to Row 144. SHAPE RAGLAN FULL FASHION: ON EACH SIDE, decrease 2 sts. 11x BUT AT THE SAME TIME, after Row 168, bind off the center 6 sts., put the needles on the left into holding position and complete the right side first.

*continue the raglan decreases to row 208. Remove the remaining sts. onto contrast waste yarn.

Bring the needles on the left into working position, knit 1 row to the left side, turn the Row Counter back to 168 and complete the left half. Follow the instructions from *.

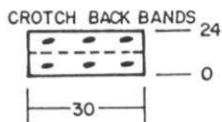

CROTCH BACK BAND: - leg bands must be completed first.

Cast on 30 sts. and work Stockinette stitch. After Row 6, MAKE BUTTONHOLES. Transfer the 5th stitch ON EACH SIDE to a neighboring needle (toward the center) and transfer the center stitch to neighboring needle. Leave empty needles in work. Knit 12 rows then REPEAT THE BUTTONHOLES. After Row 24, Hang the hem then pick up open sts. plus leg band sts. Knit 1 loose row then bind off. Make FRONT crotch band the same way but OMIT BUTTONHOLES.

FRONT:

OPEN CAST ON 22 sts. same as you did for back. After Ravel Cord row, change to garment yarn and put Counter at 0. ON EACH SIDE, increase 1 st. FULL FASHION - every 2nd row 27x. Knit to Row 70. BEGIN LACE PATTERN OVER THE CENTER 24 stitches ONLY.

After Row 138, SHAPE RAGLAN same as before, ON EACH SIDE, decrease 2 sts. every 6th row 10x and AT THE SAME TIME, after Row 172, bind off the center 24 sts., put the needles on the left into holding position and complete the right side first. *Continue to shape raglan and ON NECK SIDE, decrease 1 st. every 3rd row 6x. After Row 194 bind off. Bring the needles on the left into working position, knit 1 row to the left side, turn the Row Counter back to 172 and complete the left half. Follow the instructions from *.

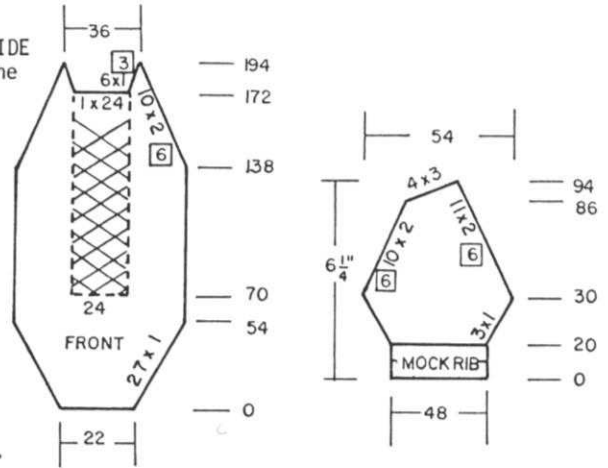

SLEEVES: Make 1, reverse 1.

Bring 48 needles into working position then push back every other needle to 'A' out of work position. With Tension 4, knit 20 rows Mock Ribbing. Hang the hem on the empty needles.

ON EACH SIDE, FULL FASHION INCREASE same as back and front, 1 st. every 2nd row 3x.

After Row 30, SHAPE RAGLAN same as before - 2 sts. every 6th row 11x on the RIGHT, 10x on the LEFT (reverse sides for 2nd sleeve).

After Row 86, work SHORT ROWS. on the LEFT, put into holding position 3 sts. 4x.

After Row 94, remove the sts. onto contrast waste yarn.

LEG BANDS; Sew sides of back and front together FIRST.

Bring 80 needles into working position then push back every 2nd needle to 'A' out of work position. With Tension 4, Knit 16 rows, Hang hem onto empty needles. Pick up sts. around the leg, knit 1 loose row then bind off. Make 2nd leg band.

NECKBAND: - Sew in sleeves FIRST.

Bring 92 needles into working position then push back to the out of work position every other needle same as you did before. Work 16 rows MOCK RIBBING with TENSION 4. Hang hem on the empty needles then pick up sts. around neck (wrong side facing you). Knit 1 loose row then bind off.

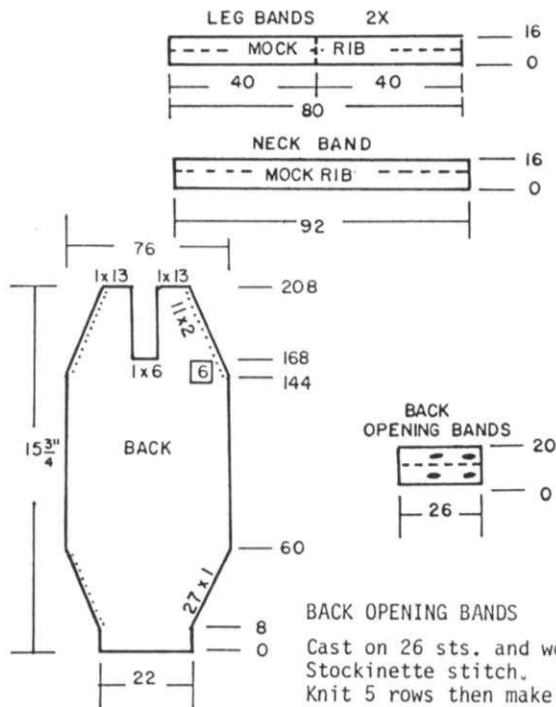

BACK OPENING BANDS

Cast on 26 sts. and work Stockinette stitch. Knit 5 rows then make 2 Buttonholes. Counting from the right, transfer the 5th st. to the 6th needle and the 15th st. to the 16th needle. Leave empty needles in work. Knit to Row 15 and REPEAT the buttonholes over the same needles.

Knit to Row 20. Hang the hem then pick up sts. along right back opening. Knit 1 loose row then bind off. Make a second band the same but omit the buttonholes and hang other side of opening onto the same needles, knit 1 loose row and bind off. Place the back buttonhole band on top of button band and sew in place. Sew on buttons.

FINISHING: See General Instructions.

**
* Lace Carriage - 4x
Knit 2 rows.
REPEAT FROM * 3x.
Lace Carriage 4x
Knit 4 rows **
REPEAT FROM **

 480



BABY BLANKET & PILLOW COVER

SIZE:
Blanket: 34" x 40 3/4"
Pillow: 15 1/2" x 9 1/2"
YARN: Daisy
AMOUNT: 7 balls for both
TENSION: 10+ (as loose as possible)
GAUGE: 11 sts.17 rows = 2" (5 cm)

Lace and Stockinette stitch with
crochet border.
Punch Card.

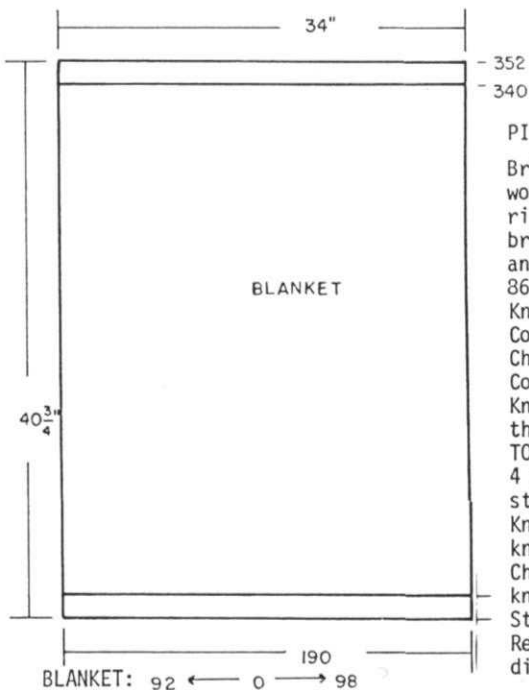
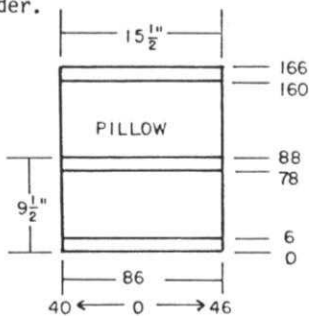

PILLOW:

Bring needle 40 on the left into working position and needle 46 on right into working position then bring all needles between into work and with contrast waste yarn, cast on 86 sts.

Knit 11 rows then 1 row with Ravel Cord to the right side. Change to garment yarn and put Counter at 0.

Knit 6 rows Stockinette stitch then BEGIN LACE PATTERN. BE SURE TO USE THE L POINT CAMS for 4 needles at EACH END to keep these stitches in Stockinette stitch.

Knit in Pattern to Row 78 then knit 10 rows Stockinette stitch. Change back to Pattern and knit to Row 160. Change to Stockinette stitch to Row 166.

Remove onto waste yarn same as you did for blanket.

FINISHING:

Blanket: - Work 1 row single crochet around all edges and remove waste knitting.

Begin at one corner and attach yarn. In next stitch, *MAKE POPCORN. Yarn over hook and pull up loop 3 times. Yarn over hook and pull through all loops on hook.Chain 1 to lock. Chain 2, single crochet into first chain. Chain 1, MAKE POPCORN in same space as first popcorn. Skip 2 on edge of blanket and REPEAT FROM * making 3 chains in each corner. If you like, you can make any edging of your choice.
Pillow Cover: - Purchase or make a baby pillow.

Bring needle 92 on the left into working position and needle 98 on the right into working position then bring all needles between into work and with contrast waste yarn, cast on 190 sts. Knit 11 rows then 1 row with Ravel Cord to the right side. Change to garment yarn and put Counter at 0. Knit 12 rows Stockinette stitch then begin LACE PATTERN. BE SURE TO USE THE L POINT CAMS for 8 needles at EACH END to keep these stitches in Stockinette stitch. Knit in Pattern to Row 340. Change to Stockinette stitch and knit to Row 352. Knit 10 or 12 rows with waste yarn and remove the sts. from the machine.

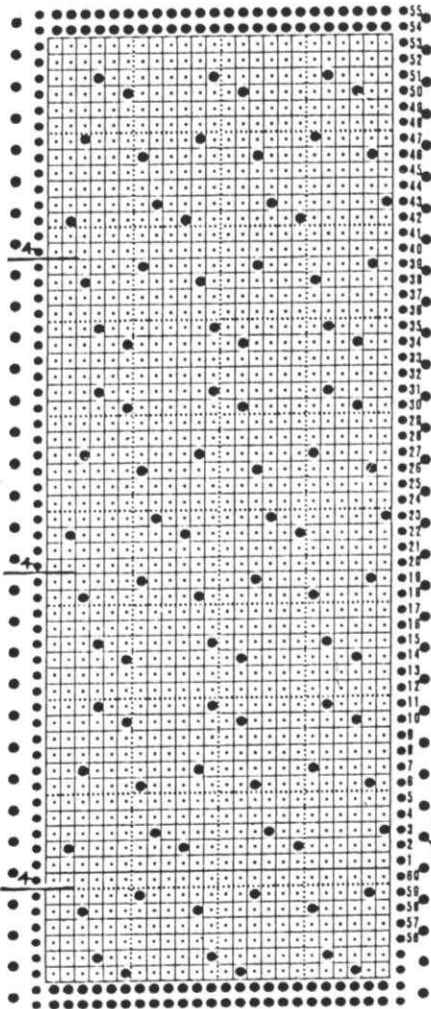

Fold Cover in half and sew up long end and 1 short end. Make same edging as blanket around all edges. Insert Pillow.

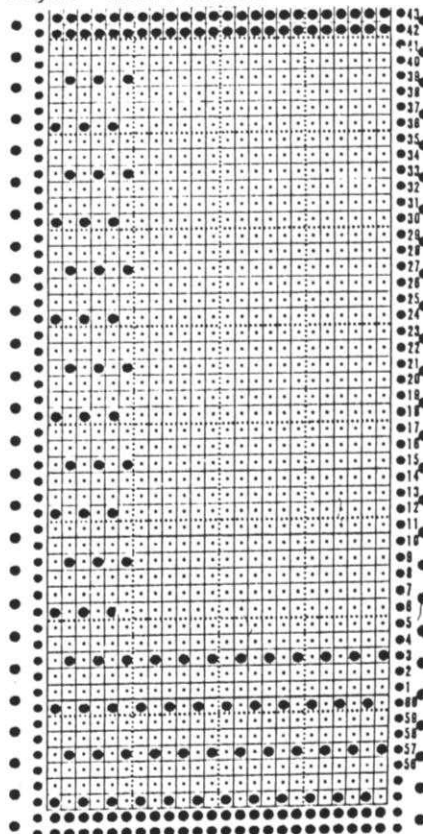



HOW TO SELECT NEEDLES TO USE FOR A PATTERN STITCH, THAT MUST HAVE OUT OF WORK NEEDLES.

Bring the required number of needles into working position (B position) DO NOT SKIP or leave any needles out of work. You must have ALL NEEDLES.

If there are two different sets of needles to be selected within the Pattern, you must set the Pattern needles two times.

Put Control on KC - Set Card on first pattern set row. Move the Carriage across. Some needles will be selected. Bring these selected needles into HOLDING POSITION and put Holding Cam on H (to hold the needles).

Set the Card on next set of needles to be selected for Pattern - Move the Carriage across. Bring these selected needles into holding position.

NOW PUSH ALL the remaining needles that are left in work (B) position to the OUT OF WORK (A) position.

You now have the proper needles needed for your Pattern Stitch - These are the needles that are still in holding position. Push the needles back to working position and release holding Cam. Cast on and you are ready to knit - BUT FIRST you must turn the Carriage over and move the end needle selecting Cams on each side of Carriage to the HORIZONTAL position. Remember to turn the Cams back to the vertical position when you complete knitting with out of work needles.

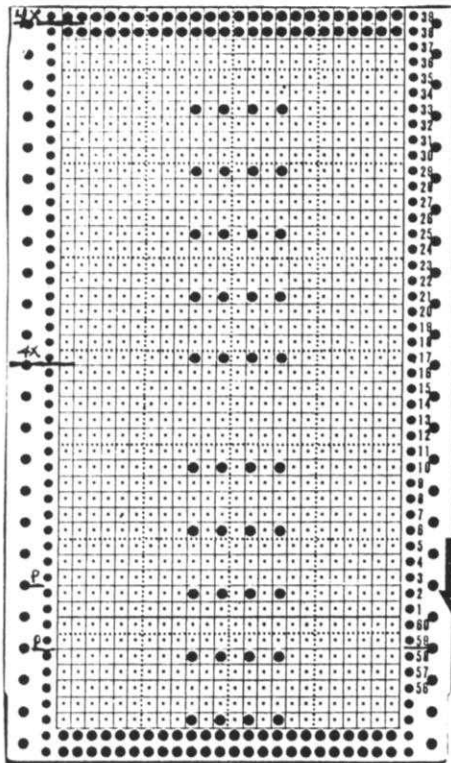

LACE PUNCH CARDS FOR SINGER/STUDIO MACHINES

The Lace Motif shown here is for the SINGER/STUDIO machines. The original card for KNITTING machines was printed in our KNITTING MAGAZINE, Volume 19 No. 2 - Pattern No. 439. It is a small size motif for making a table runner.

The SINGER/STUDIO Lace Carriage transfers and knits at the SAME TIME. In order for you to knit lace patterns as shown for the KNITTING Punch Card machines, the Cards must be punched a bit differently to obtain the same results in Lace. We are showing you this one example for changing a Punch Card. You may find two or three other ways that could make other Lace Designs easier. Just remember that you must begin punching design on the FIRST ROW of Card no matter what number shows on the right side. For the SINGER/STUDIO, the card is set 5 rows up (The 6th row begins the pattern marked on the first row of card). If there is a blank space on first row of card, leave it blank, if there are punched holes for first row, you must punch the line as shown.

After punching the design, follow the instructions below.

LEAVE LACE CARRIAGE CONTROL ON TRIANGLE.

*Control on P - NO YARN IN FEEDER.

(At setting P - the carriage will only set the needles or transfer stitches - it WILL NOT knit).

Move the Lace Carriage 2x.

RELEASE P - PUT YARN IN FEEDER - KNIT 2 ROWS.

REMOVE YARN FROM FEEDER.

REPEAT FROM *.

(Be sure to KNIT THE 4 ROWS between as shown on the Card).

YARN KITS FOR GARMENTS IN THIS ISSUE

Most of the garments in this issue of KNITTING MAGAZINE were knitted with yarns from our YARN CATALOGUE which illustrates the full range of colors available and includes actual yarn samples. If you do not have our Catalogue, please send \$3.00 and we will mail you one immediately. You will then be able to choose your own colors.

VENETIA, our best selling yarn is not shown in the catalogue. We have the following colors available and you should always give two alternate colors. PINK, WHITE, BLACK, LIGHT BLUE, NEW LILAC, CONCORD GRAPE, OFF WHITE, DARK NAVY, CHAMPAGNE TWEED, LIGHT GREY, RED.

THIN VENETIA (also called FINE VENETIA) is available in the following colors. (Please give two alternate colors). CHOCOLATE BROWN, WINE RED, TAUPE, DARK TURQUOISE, BRIGHT YELLOW, OLIVE GREEN.

No. 461 - Yarn:	Venetia		
SIZES:	6/8	(10/12)	[14/16]
Price:	\$44.48	\$44.48	\$55.60
Shipping:	2.50	2.50	2.50
No. 462 Yarn:	Roma and Angora		
SIZES:	6/8	(10/12)	[14/16]
Price:	\$11.02	\$11.02	\$11.02
Shipping:	1.85	1.85	1.85
No. 463 - Yarn:	Alanda		
SIZES:	6/8	(10/12)	[14/16]
Price:	\$22.70	\$24.30	\$25.90
Shipping:	1.85	1.85	1.85
No. 464 - Yarn:	Venetia		
SIZES:	6/8	(10/12)	[14/16]
Price:	\$44.48	\$55.60	\$55.60
Shipping:	2.50	2.50	2.50
No. 465 - Yarn:	Alpacana		
SIZES:	38/40	(42/44)	[46]
Price:	\$39.00	\$39.00	\$39.00
Shipping:	1.85	1.85	1.85

- No. 466 - Yarn: Venetia, Beatrice, Angora
 SIZES: 10/12 (14/16) [18/20]
 Price: \$51.26 \$51.26 \$51.26
 Shipping 2.50 2.50 2.50
- No. 467 - Yarn: Venetia
 SIZES: 6/8 (10/12) [14/16]
 Price: \$44.48 \$44.48 \$44.48
 Shipping: 2.50 2.50 2.50
- No. 468 - Yarn: Bravo and Extra
 SIZES: 8/10 (12/14) [16/18]
 Price: \$22.10 \$22.10 \$23.65
 Shipping: 1.85 1.85 1.85
- No. 469 - Yarn: Cordella
 SIZES: 8/10 (12/14)
 Price: \$15.92 \$15.92
 Shipping: 1.85 1.85
- No. 470 - Yarn: Venetia and Regia
 SIZES: 38/40 (42/44) [46]
 Price: \$24.44 \$35.56 \$35.56
 Shipping: 2.50 2.50 2.50
- No. 471 - Yarn: Bravo
 SIZES: 40/42 (44/46)
 Price: \$17.05 \$17.05
 Shipping: 1.85 1.85
- No. 472 - Yarn: Alanda
 SIZES: 8 to 14
 Price: \$24.00
 Shipping: 1.85
- No. 473 - Yarn: Cordella
 SIZES: 1 year to 18 months
 Price: \$7.96
 Shipping: 1.85

- No. 474 - Yarn: Roma
 SIZES: 10/12 (14/16)
 Price: \$12.42 \$13.00
 Shipping 1.85 1.85
- No. 475 - Yarn: Marisa 100% Cotton
 SIZES: 4/6 (8/10) [12/14]
 Price: \$22.24 \$27.80 \$27.80
 Shipping 2.50 2.50 2.50
- No. 476 - Yarn: Venetia
 SIZES: Large - 42/44
 Price: \$41.70
 Shipping: 2.50
- IMPORTANT: - We will supply full size copies of original drawings (2) for an additional \$1.00 and include it with your kit - or you can purchase the SINGER/STUDIO BOOK - Pattern Collection No. 4 on sale for \$18.95 plus \$1.50 shipping costs.
- No. 477 - Yarn: Alanda and Amore
 Price: \$9.58
 Shipping: 1.85
 Colors 2, 3, 4, 5, 6 uses very small amount of Amore (you can use any similar weight yarn) and is NOT INCLUDED IN KIT. The knitting worsted needed for hair is NOT included in Kit.
- No. 479 - Yarn: Amore
 SIZES: Newborn to 6 months
 Price: \$4.79
 Shipping: 1.85
- No. 480 - Yarn: Daisy
 Price: \$11.20

Join the Club!
 The KNITKING Knitting Club...

Our good looking light weight 50% Cotton, 50% Acrylic Sweat-shirt (Made in the U.S. by Hanes) is the first in a line of merchandise designed especially for knitting machine knitters. It will be followed by a specially designed Apron and a heavy canvas Bag for carrying your knitting or anything else you desire. All merchandise will bear the KNITKING CLUB Emblem.

Wear the Shirt on the street and to the stores, other knitters will introduce themselves to you, you will make new friends and you will help make machine knitting more and more popular.

Available now in Medium 38/40 or Large 42/44. If there is a demand for small and extra large, we will make them.

Shirts are White with Red or Blue lettering.

Join today by sending \$19.95 plus mailing costs \$1.50 (Calif. residents add Sales Tax) to

**KNITKING - 1128 Crenshaw Blvd.,
 Los Angeles, CA 90019**

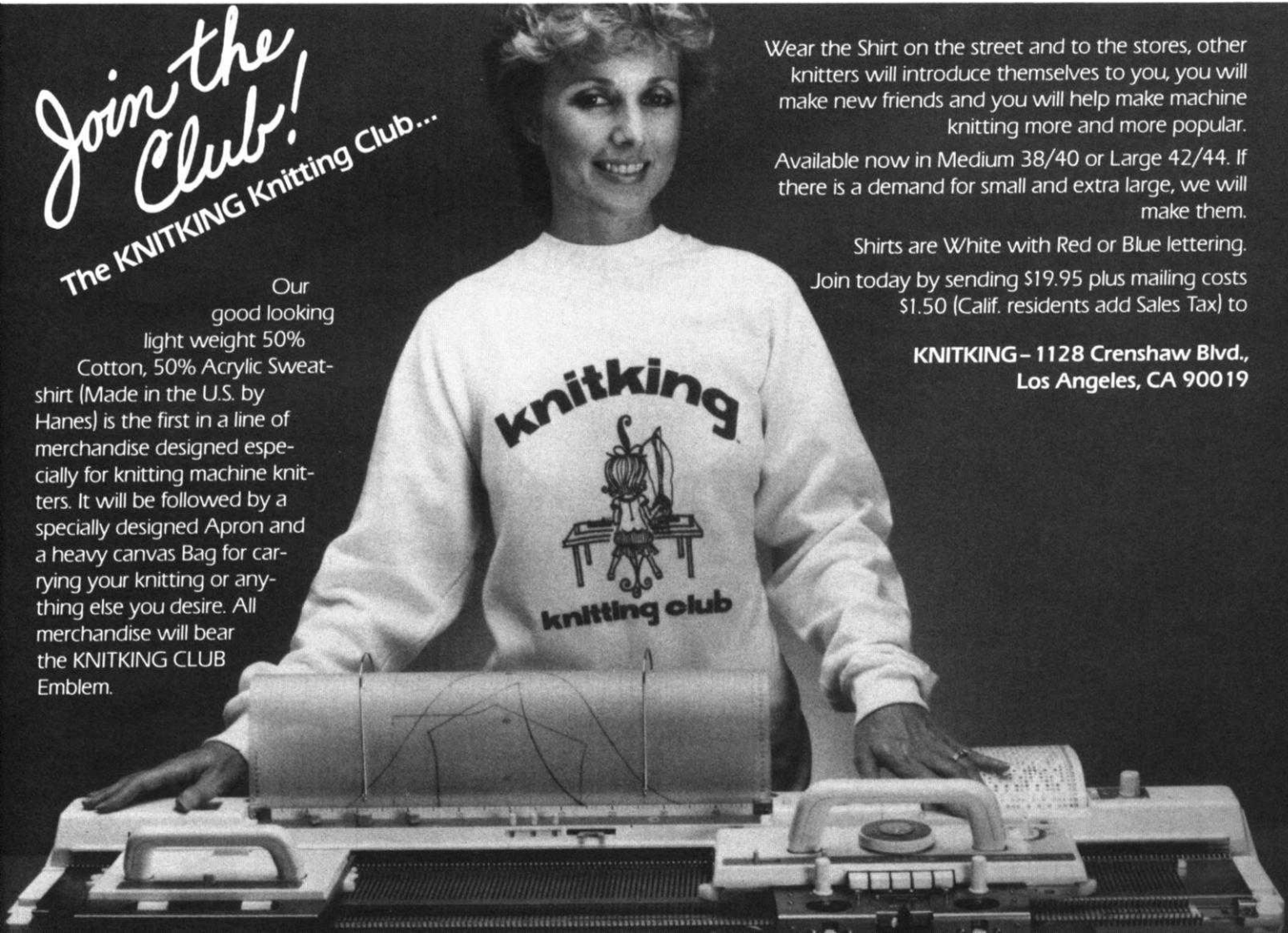

knitking

KNITTING COMPUTER

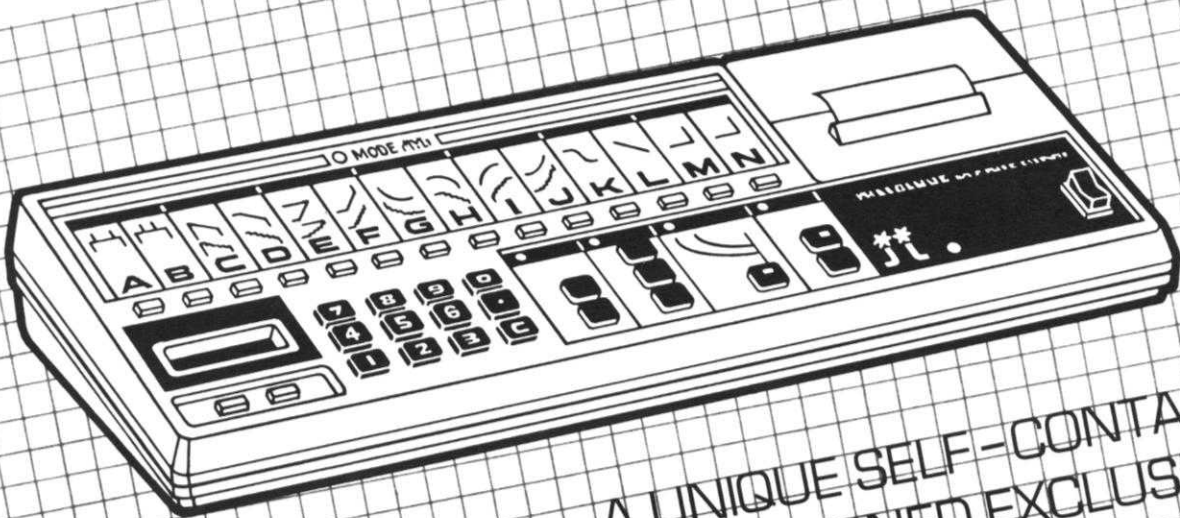

A UNIQUE SELF-CONTAINED
COMPUTER DESIGNED EXCLUSIVELY
FOR HAND AND MACHINE KNITTERS.

Every shape of garment sections, necklines, armholes, etc., is represented by a 'MODE' button. Push a Mode Button, program in your Stitch and Row Gauge, follow it with the Width and Length of the garment section, then watch the printer print out complete knitting instructions.

The Computing of knitting patterns can be done with standard computers plus expensive software, and you can easily spend thousands of dollars to obtain the same results as produced by the KNITTING Knitting Computer at a fraction of the price.

The KNITTING Knitting Computer operates with built in re-chargeable Nickel Cadmium Batteries. A charger is standard equipment as is a detailed Instruction Manual and some spare rolls of print out tape.

Price: \$499.00 (California residents add Sales Tax)
Order from your local dealer or direct from

**KNITTING — 1128 Crenshaw Blvd.,
Los Angeles, CA 90019**

 462
Quick
Knit

A single motif Butterfly adorns the front of an easy to knit sleeveless Pullover. It's programmed on the KH 910 (or any Electronic machine). Knit it with our brand new Roma with Angora for the Butterfly. Sizes 6 to 16.



COMPUKNIT KH 910

'the world's finest knitting machine'

- Incredibly versatile... Anything you can trace or draw is automatically reproduced in your knitting in the colors and yarns of your choice.
- Simple to program and easy to operate, the COMPUKNIT KH 910 is the 'state of the Art' in home knitting machines. It is the only knitter made that has a memory unit to retain your program if you suffer a power outage or wish to move your knitter from one place to another.
- The maximum width of motif or pattern design possible on any punch card machine is 30 stitches (the standard is 24). The COMPUKNIT has no limit. It is possible to knit a single picture or lace design over the full width (200) needles of the needle bed. It will, in fact, do everything that's possible on a punch card machine and much much more.
- If you already own a knitting machine, you must consider trading up to a fantastic COMPUKNIT 910. If you have never owned a knitter before, start at the top and save money and save all the intermediate steps.



Order from your local Dealer or direct from
VISA and MASTERCARD accepted

KNITTING

1128 Crenshaw Blvd.
Los Angeles, CA 90019
Telephone: (213) 938-2077

465
New
Dimensions

The subtle shadings of a new Pullover will please any Man. Patterned on the front only, each separate design is knitted in strips (pick up the stitches from ribbed band) then sewn together. It is easy to knit and we used soft Alpacana. Sizes are from 38 to 46.



KNITKING KH 891 WITH KG 89 ELECTRIC CARRIAGE

Feed in a pattern stitch card. Set the row counter to a specific number of rows, then push the start button and you can leave to watch T.V. or cook the dinner, read a book, etc., while your knitter knits merrily along. When it has knitted the preset number of rows, it will switch itself off. If it runs out of yarn, it will switch itself off. The KG 89 Electric Carriage will knit an unlimited variety of fancy Garter Stitch designs in addition to standard ribs.

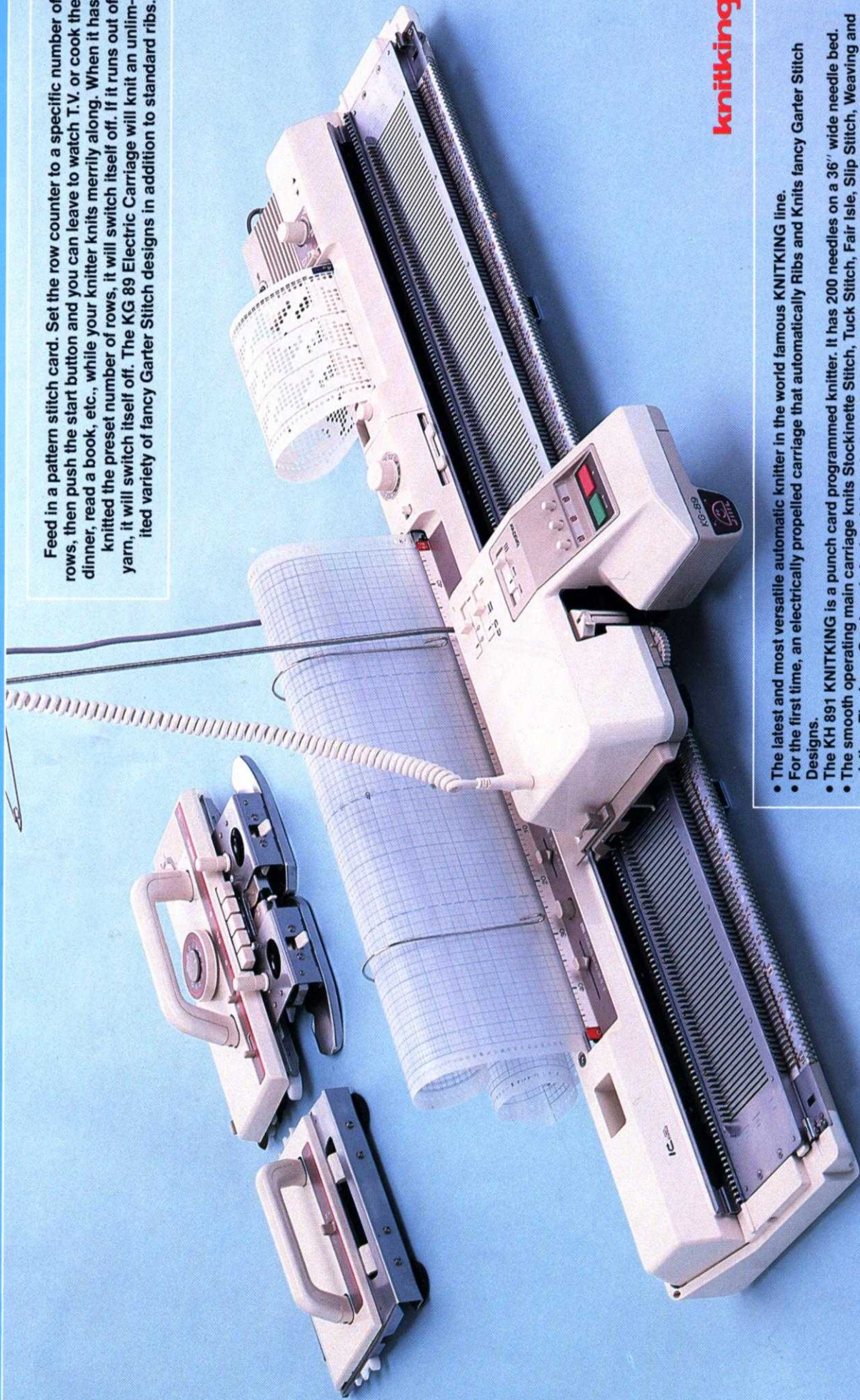

knitking

- The latest and most versatile automatic knitter in the world famous KNITKING line.
- For the first time, an electrically propelled carriage that automatically Knits fancy Garter Stitch Designs.
- The KH 891 KNITKING is a punch card programmed knitter. It has 200 needles on a 36" wide needle bed.
- The smooth operating main carriage knits Stockinette Stitch, Tuck Stitch, Fair Isle, Slip Stitch, Weaving and plying. The Lace Carriage is for lovely lace designs, both standard and fine.
- 20 Pre-Punched Pattern Cards for all types of pattern knitting are included with every machine. The built-in Knitleader Charting accessory tells you on a row by row basis when to increase and when to decrease. Simplifies the knitting of garments to accurate size.
- A complete kit of Tools, spare needles, cabling tools, lubricating oil and two, step by step Instruction Manuals with over 400 illustrations are included and there is a one year warranty on parts and service.

Order from your local dealer or direct from **KNITKING**—1128 Crenshaw Blvd.
Los Angeles, CA 90019



471

Easy

Fit

Sportswear

A Tuck stitch using heavy weight yarn for a Pullover Vest will give plenty of wear for your special Man. Knit it on the KH 260 Punch Card Bulky using our Bravo yarn. Sizes 40 to 46.

473
Play
Time

She will be warm and happy wearing a new Pullover made with several colorful Fair Isle Designs. Use our wash and wear Cordella and knit it in sizes 1 year to 18 months.



 477
Katys
Cousin
Klara...

She's cute and cuddly and she does not mind if you skip the soft sculpture- Just embroider her face and knit her Dress, Panties and Shoes to make any little girl happy. Alanda and Amore yarn. See Instructions for small amounts not included in Kit.



☒ 480
Sleepy
Time...

Cover your baby or newest grandchild with a lovely lace Blanket. It has a matching Pillow Cover, is easy to knit and super soft to the touch when made with our Daisy yarn.



479
Romper
Room
Set...

Baby can play in comfort in a soft Romper that has an isolated lace pattern down the front. Easy wash and wear. Amore is the yarn and sizes are newborn to 13 months.

 470
Anchors
Aweigh!

A boating buff will surely enjoy wearing a great Pullover. An anchor in an isolated Fair Isle design is on the left front and narrow stripes are on the right sleeve. A big range of sizes from 38 to 46. Knit it with Venetia and Regia.



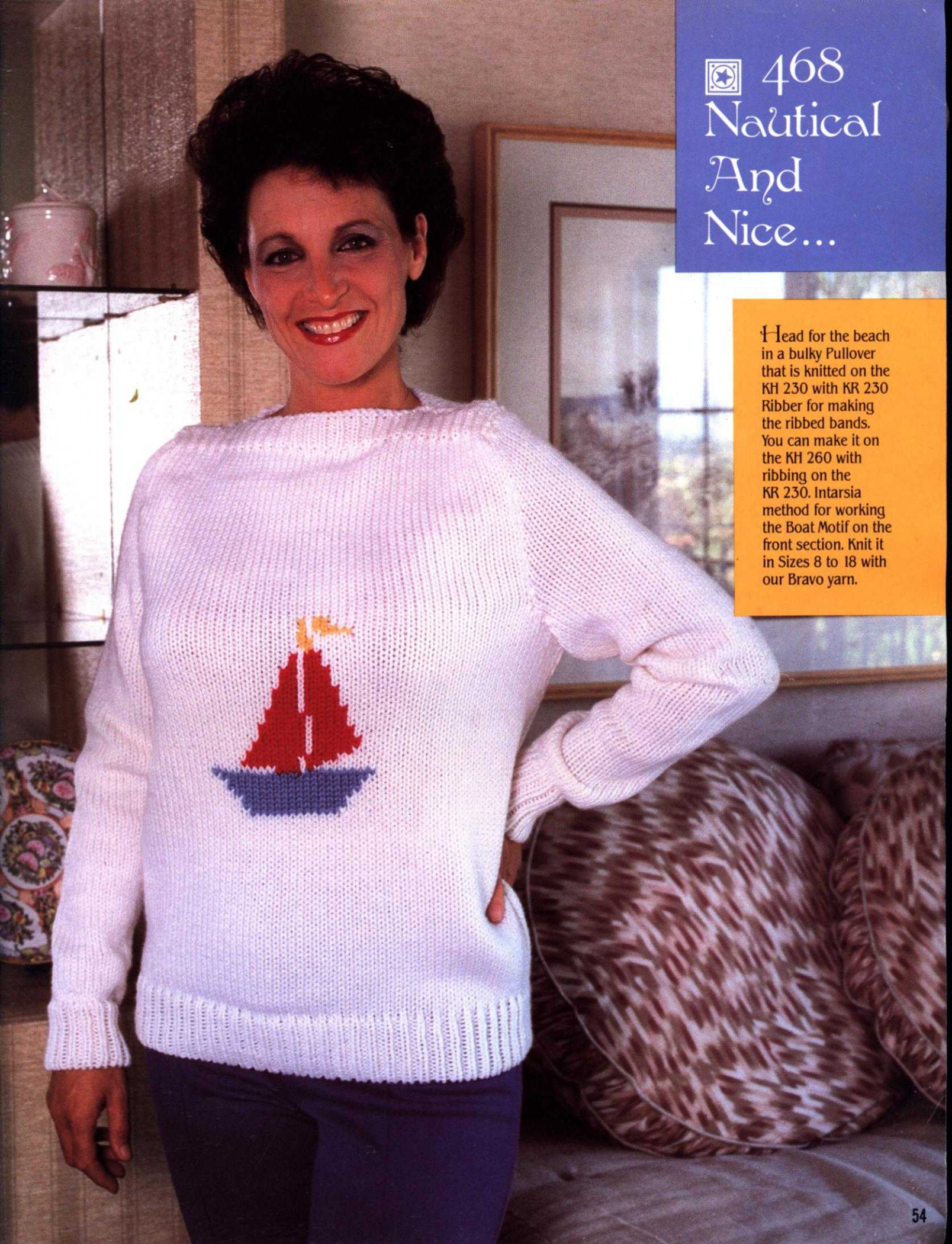

468
Nautical
And
Nice...

Head for the beach in a bulky Pullover that is knitted on the KH 230 with KR 230 Ribber for making the ribbed bands. You can make it on the KH 260 with ribbing on the KR 230. Intarsia method for working the Boat Motif on the front section. Knit it in Sizes 8 to 18 with our Bravo yarn.

JUMBO Genie

"The magic knitter"

JUMBO GENIE IS A
BULKY BEST BUY...check
its price and versatility
against other brand
bulky knitters.

It's a full size, 120 plated steel needles (8mm spacing) knitter that is just perfect for knitting 4 ply worsted weight yarn. Its range is from sport weight to jumbo yarn...Mohair, Angora, Nubby, Boucle, etc., etc....it knits them all.

The JUMBO GENIE has Intarsia and Tuck Knitting Controls built into the carriage. You pay extra for Intarsia knitting on some other machines. A row counter, kit of tools and instruction manual is standard with every machine and the JUMBO GENIE knitter weighs 20 lbs.

The JUMBO GENIE has an all hardened steel (not plastic) needle bed for continuous smooth operation. Twin overhead adjustable yarn feeders and easily adjusted tension control for different weights of yarn.



KNITTING Discount price for S-120 Knitter \$199.95
KNITTING Discount price for R-120 Ribber 199.95
Combination Price \$399.90

Order from your local Dealer or direct from

KNITTING
1128 Crenshaw Blvd.
Los Angeles, CA 90019
(213) 938-2077

The JUMBO GENIE Ribbing Attachment converts the JUMBO GENIE knitter into a Double Bed machine with a total of 240 needles...you can actually knit rib design garments with dress yarns using all of the needles and you can knit zig zag rib designs with the built in racking device.
After knitting ribbing for a garment, the ribber drops down and allows you to continue knitting on the main machine.



VISA and MASTERCARD accepted