

VOL. 20th 4

knitking

magazine



Rich and

Elegant...
Our latest
fashions
will make
you look like
a million!

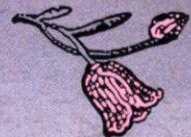



546
Pink
Sherbet

For all romantics, a soft, flowing feminine dress to wear to a candle lit dinner or a special outing. The delicate lace Pattern on the bodice is repeated at hemline and sleeve cuffs. It's knitted with Roma

545 Dress & Topper

Gracious lines, big pockets, and easy knitting make up this full length Coat. It's knitted in full needle Ribbing as is the slinky long sleeve Dress underneath. A perfect combination for casual or dressy wear. Knit it with our Venetia.



Table of Contents

Editorial

VOLUME 20, NO. 4

TABLE OF CONTENTS	PAGE NO.
541 - Womens Butterfly Top	13
542 - Womens Dolman Sleeve Blouse & Skirt	15
543 - Womens Tunic	17
544 - Womens Dress & Jacket	18
545 - Womens Dress	20
545B Womens Coat	21
546 - Womens Dress	22
547 - Womens 2-Piece Dress & Lace Petticoat	23
548 - Womens Feather & Fan Top & Skirt	24
549 - Womens Dress	26
550 - Womens Tunic	28
551 - Womens Dress	29
552 - Womens Dress	31
553 - Womens Cardigan	32
554 - Womens 2-Piece Suit	33
555 - Womens 3-Piece Ensemble	35
556 - Womens & Child's Intarsia Cardigan	37
557 - Womens Evening Jacket & Skirt	39
558 - Womens Skirt & Top	41
559 - Womens Garter Stitch Dress	43
560 - Mens Sweater	44
561 - Mens Striped Sweater	46

Only when it is your business that suffers from a fire, do you realize how devastating and far reaching its affect can be. The fire at KNITKING on Sunday, June 22nd ruined the Shipping and Receiving Department and our major warehouse plus the KNITKING MAGAZINE Design and Production Department. Many garments planned for future editions were destroyed and have to be re-made. Much of the written material suffered water damage and is no longer legible.

Fortunately, the color photos for this issue were at the Color Litho house and escaped damage but we are behind schedule in the magazine production department which is now sharing space normally allocated entirely for teaching purposes. We are rapidly rebuilding the burned out structure and by the time you receive this magazine, we will have resumed our normal hectic pace. In the meantime...we apologize for the delay in getting this Edition to you. Incidentally, we hope you will agree that it is truly outstanding.

Our last issue, Volume 20 #3, should have been delivered to us by the printer on June 20th...this was one occasion when we did not complain about its late arrival. Had it been on our premises on the 22nd, it would definitely have been burned to a crisp in our Shipping Department. It arrived two days after the fire and was on its way to you a day later.

COMPUKNIT III

Our first shipment of these remarkable machines arrived a month after the fire...We unloaded them on to our parking lot where previously prepared labels were attached and where U.P.S. trucks arrived at pre-arranged intervals to haul them off to ecstatic customers, many of whom have since communicated their excitement and enthusiasm directly to us.

There is no doubt about it...the COMPUKNIT III is *the* machine of today. Its versatility and simplicity of operation is beyond compare. Couple the COMPUKNIT III with the KG 93 Garter Carriage and you have a reasonably priced combination that already promises to be a runaway best seller. Incidentally, customers tell us they use the KG 93 for automatically casting on all of their knitting. It gives a perfect cast on edge as well as a beautiful automatic bind off...

Many readers have been asking for an Automatic Color Changer for the KH 260 and we are happy to tell them that the KRC 900 4 Color Changer is available. It functions on all KNITKING machines with Ribbers from the KH 830 through the COMPUKNIT III including, of course, the KH 260 with KR 260 Ribber.

557 Gracious

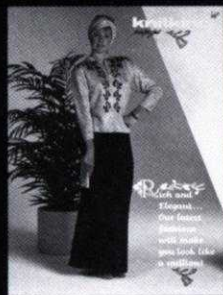

Knit our beautiful Cover Model Dress and make your presence known. A worthwhile challenge for using your Electronic machine and Ribber with Color Changer. A single Motif Fair Isle Design is on the front of Jacket and there are no floats on the back. A special knitting technique automatically makes the lining. The Skirt is 2X2 ribbing. Fine Venetia and Silver Blue Capriccio.







544 S hades of the Mikado

Knit a cool simple Dress without sleeves then top it with a Lace Jacket (Pattern Stitch 637 from our Pattern Stitch Book) with bands of color at shoulders that are held perfectly in place with shoulder pads. Venetia is the yarn.

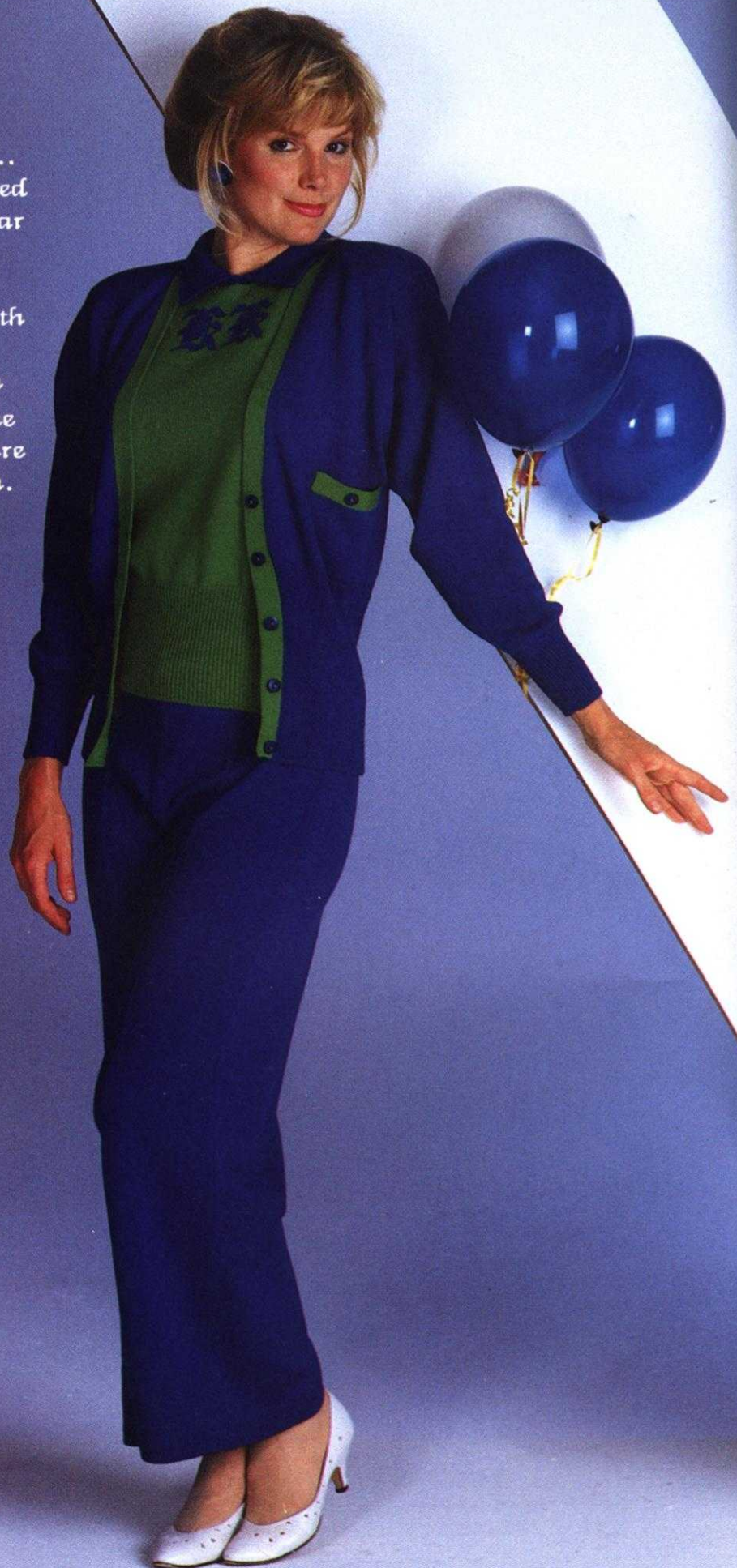

555 Ensemble

Don't pass this one up...
A completely coordinated
three piece outfit to wear
and wear. Make it on
any standard machine
in Stockinette stitch with
Ribber. The pants are
straight legged. Knit in
your own initials on the
front of pullover. Be sure
to use our Venetia yarn.





554

Important Fashion Scoop

Knit this stunning two piece Dress in Stockinette stitch. It is beautifully designed and has the softness women love. Pleats at shoulder and perky bows for a designer touch. Venetia is the yarn.



559 Pink Ice

Turn on your Garter Carriage for this one and you can take off for the day. You will be delighted with a soft and flattering Dress that is very easy to knit. The yarn is called ICE CREAM and it is soft and smooth.



558

Delightful Duo

A two piece Dress to brighten your wardrobe has single Motif Flowers on the pretty Top. Knit it on your Electronic machine. The ribbed Skirt is made using the Garter Carriage. Venetia and Angora with a small amount of Isabella for the leaves.



548 Feather & Fan

Everyone loves the Feather and Fan Lace Design and this elegant two piece Dress should be a part of every wardrobe. The slightly flared Skirt is Stockinette stitch and is knitted sideways on the machine.



552



ashion

Wherever you go, eyes will turn when you are wearing this Smart Dress. The surplice front bodice, the shoulder pleats lifted softly with pads make for gracious dressing. It is knitted in Stockinette stitch with Venetia.



541 Tiffany

Brilliant stain glass colors are selected for knitting a glorious Butterfly Motif for this special Pullover. You can make it on any Electronic Machine with Venetia and Isabella.



General Instructions

THE PRINTED INSTRUCTIONS

Follow the printed instructions or use them in combination with the Charts. Where there is any question in the instructions, you have the Charts to show you how the section will look.

Be sure to READ AHEAD so that you KNOW what to do for the size you are knitting. In the shapings, where the number of stitches are the same but the number of times different, you might find shapings like this... 3 sts. 1x (2x) [3x]—so that for the first size you will bind off 3 sts. 1x, 2nd size 3 sts. 2x, 3rd size 3 sts. 3x. Sometimes the ROWS will be different for each size—so you must watch out for different row numbers.

Shoulder and neck shapings for the back section of a garment usually are shaped at the same time—so ALWAYS WATCH for the words AT THE SAME TIME.

HOLDING STITCHES ON THE LEFT SIDE WHILE SHAPING THE RIGHT SIDE

There are different ways to hold stitches on one side while completing the other side. Usually, we tell you to bind off the center sts. for neck and put the left side into holding position while completing the right side. The easiest way and really the best way for beginners is to take a piece of RAVEL CORD and hand knit the center neck stitches, pulling them back against the needle bed of machine to the "A" or out of work position. The stitches remain in the HOOKS of the needles so you are really only knitting them HALF WAY. With another color of Ravel Cord, knit the remaining sts. on the left side in the SAME WAY.

It is important to protect these held stitches in some way—so you can either hang a REVERSING BAR so that the EYES of the Bar go BETWEEN the Gate Pegs on the machine and that the UPPER TIPS of Bar only—show above the needle bed...OR the simplest way is to use a piece of 1 inch masking tape and GENTLY place it beneath the knitting—right below the gate pegs. Do NOT press the tape—only enough pressure to hold it in place. This will prevent the Carriage (or Slide) from marking the held section.

It is VERY IMPORTANT that you mark the PATTERN ROW where you divide for the split for NECK (or SHOULDER) shaping... If you are using a PUNCH CARD—MARK THE CARD—if you are using an ELECTRONIC machine, MARK THE DESIGN WINDOW. Also take note of the Row number for the division. When you are ready to work the left section, bring the HELD stitches back to B (working) position by pulling each end of the Ravel Cord GENTLY and rip it off—be sure to align all needles straight in the B or knitting position.

Now you are ready to REFER TO YOUR OWN INSTRUCTION MANUAL for your machine—to set the controls to begin knitting the left half. The neck stitches can be bound off after completing the right side or you can leave them in hold until each side is finished, then bind them off or remove them onto contrast waste yarn ready to be picked up for knitting a neckband or for other finishing.

FULL FASHION DECREASING OR INCREASING

For Stockinette stitch, use the Full Fashion method for decreasing or increasing (except for regular cap shaping on sleeves where you decrease the edge stitch).

TO DECREASE: Hang the 3rd stitch onto the 2nd stitch then move the end stitches in to fill the empty needle.

TO INCREASE: Move the 2nd end stitches 1 needle outward, then pick up the 3rd stitch from the row below and hang it onto empty needle.

PATTERN SYMBOLS (Code for Symbols on page 13.)

() Symbol for 2nd size.

[] Symbol for 3rd size.

There are up to 3 sizes given for Patterns in KNITTING MAGAZINE. For example, the Charts and printed instructions will show the cast-on as... 124—First size. (132)—Second size. [140]—Third size.

R = ROW

• Needles in holding position.

⊗ Needles back into working position.

< For Short Row Knitting

THE SAMPLE SWATCH

Before you knit any garment, you must knit a sample swatch using the yarn you have chosen for your garment. If you do not get the correct Stitch and Row Gauge as given for a Pattern in KNITTING MAGAZINE—try different tensions. If you are using the specified yarn, you should be able to get the correct gauge using a smaller or larger tension. If you are using a different yarn, you may have to make several swatches—but the gauge is very important.

To make a sample swatch—Cast on 60 stitches with waste yarn and knit 6 rows. Mark the tension number for your sample swatch by making holes (you can do this with a Lace Carriage or by hand), 4 transfers for Tension 4, 6 transfers for Tension 6, etc. Knit 6 more rows.

Change to garment yarn and set Counter at 0. Knit 30 rows (in Stockinette stitch or Pattern stitch—according to the garment). With Contrast waste yarn knit the 10th stitch FROM EACH SIDE—by hand. Knit 30 rows. Change to waste yarn and knit 12 rows. Remove the sts. from the machine by pushing the Carriage (or Slide) across without yarn.

Pull and stretch the sample swatch both lengthwise and diagonally from corner to corner, then lengthwise again. Gently block the swatch (KNITTING PRESSING CLOTHS are great for this)—or you can allow the sample to rest several hours or even over night so that the stitches can return to their basic form.

THE KNITTING STITCH/ROW GAUGE and STITCH/ROW CALCULATOR can be used to find the NUMBER OF STITCHES or ROWS TO 1 INCH.

The KNITTING STITCH/ROW GAUGE will give you the NUMBER OF STITCHES or ROWS to 1 inch. After knitting a sample swatch by following our instructions, place the STITCH/ROW GAUGE horizontally with the START LINE on the INSIDE of LEFT stitch mark on sample.

Keep it straight then read the number on the Gauge directly below the inside RIGHT mark on Gauge. This will give you the STITCH GAUGE TO 1 INCH. For instance, if the number is 8, then you have 8 stitches to 1 INCH. To find the ROWS TO 1 INCH, measure from the first row of garment yarn, VERTICALLY to the last row. Read the NUMBER from the LOWER EDGE of GAUGE same as you did for stitches and if the number should be 14, you have 14 rows to 1 inch.

The STITCH/ROW CALCULATOR will now give you the number of sts. or rows needed for a specific measurement. Line the ARROW to the number 8 (8 sts. to 1 inch) and should you need 20 inches of stitches, find the number 20 below and right above the 20 the Calculator shows 160 sts. It works the same way for rows using the Row Gauge.

12 ROWS		12 ROWS
60 ROWS	10 • 40 STS • 10 ↑ MARK ↑ MARK	30 ROWS 30 ROWS
12 ROWS	0000 TENSION HOLES	CONTRAST YARN
	60 STS	
		6 ROWS 6 ROWS

FINISHING

Gently block all sections—For PULLOVERS, JACKETS and DRESSES: Join the front to back at shoulders and sides. Sew sleeves together and set in. Hem lower edge and sleeve edges if needed. For a double neckband or armhole, band sew 1 edge to inside and 1 to the outside of neck or armhole. For a single ribbed band, sew 1 edge to the outside of neck or armhole edge. For a cardigan or jacket with buttonholes, finish buttonholes and sew on buttons.

PANTS: Join front to back at sides. Sew inside leg seams, then join to center front and back. Make hem at waistline and insert elastic. Hem lower edge of pants' legs.

∇ Needle not used—in out of work position.

3x1

4

The number in the box is the number of Rows between shapings. The 3 x 1 above the box gives you the sts. and number of times to make the decreases (or increases)—FOR EXAMPLE: 3 x 1 over the box with 4 means—At the given Row number, "decrease 1 st. knit 4 rows" and REPEAT from " to " 2 times more for a total of 3 times in all. All decreasing (or increasing) WITHOUT ROW NUMBER IN BOX must be made on EVERY 2nd ROW.

CODE FOR SYMBOLS

Carr.	Carriage
CO	Cast on
BO	Bind off
Col.	Color
Dec.	Decrease
Inc.	Increase
EON	Every Other Needle
EOR	Every Other Row
FNR	Full Needle Rib
HP	Holding Position
MB	Main Bed
RB	Ribber Bed
K	Knit
P	Purl
Pat.	Pattern
Ndls.	Needles
St.	Stitch
St. st.	Stockinette Stitch
T	Tension
WP	Working Position
L.C.	Lace Carriage
G.C.	Garter Carriage
G.S.	Garter Stitch
I.C.	Intarsia Carriage
W.Y.	Waste Yarn
Strd.	Strand

BACK:

With W.Y. cast on 140 (148) sts. Knit several rows ending 1 row Ravel Cord to the right. With Col. 1 knit 4 (6) rows, setting Pattern on last row. With Col. 1 and Col. 2, begin Pat. 1. After R 74 (76), with Col. 1, knit 6 (8) R. After R 80 (84) bring all Ndls. to HP. Begin Short Row increases. ON THE RIGHT, push back into working position, 4 sts. 35 (37)x. ALWAYS wrap inside needle to prevent holes. AT THE SAME TIME, after Row 130 (134), mark for neck opening. After R 210 (218) begin Short Row Decreases. ON OPPOSITE SIDE of Carr. bring to HP 4 sts. EOR 35 (37)x. AT THE SAME TIME, after R 230 (242), mark for Neck Opening. After R 285 (299) set for Pat. 1. (Note that Reflection Switch has different setting. TRUE REFLECTION: On 910 Machine Switch is in UPPER position. After READY LIGHT appears, PRESS ORANGE CE BUTTON then enter the last row number of Pat. on the Mylar Sheet (In this Case 70). PRESS CF BUTTON. After Row 356 (370), change to Col. 1 only and knit 4 (6) rows. Remove onto W.Y.

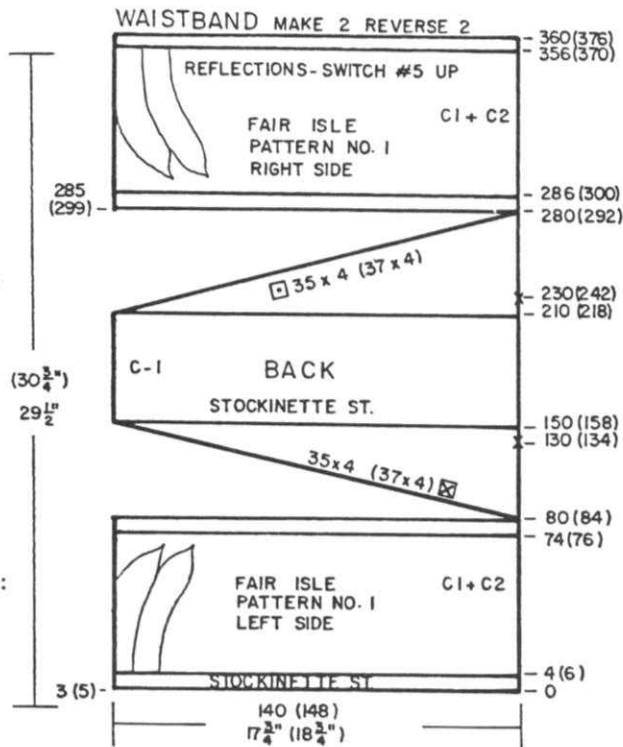

541



WOMANS BUTTERFLY TOP

SIZES: 10/12 (14/16)
 YARN: Venetia = Col. 1 & 2
 Isabella = Col. 3

AMOUNT:
 Col. 1 10 oz. Both Sizes
 Col. 2 8 oz. Both Sizes
 Col. 3 2 Balls Both Sizes
 TENSION: 5
 GAUGE: 15 1/2 Sts. 24 R = 2"

Make on any Electronic Machine. The borders are Fair Isle Design. The Butterfly is a Single Motif and is made in two sections. Follow Charts for pattern placement and setting.

FRONT PANEL: Right Side.

With W.Y. cast on 140 (148) sts. Work the waste knitting with 1 Row Ravel Cord to the right same as you did for the back. Knit in Pat. 1 with color 1 & 2 same as you did for the BACK. to R 80 (84). BIND OFF LOOSELY.

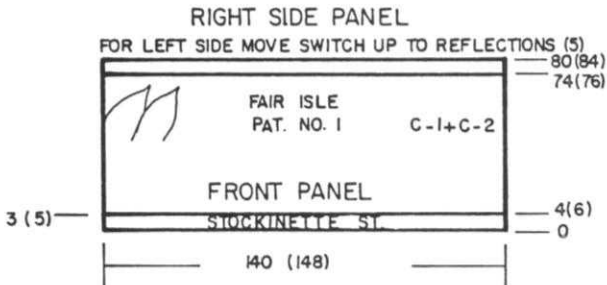

FRONT PANEL: Left Side

With W.Y. cast on 140 (148) sts. Work the waste knitting same as Back ending 1 row Ravel Cord to the right. Bring all Ndls. to HP. Using 'e' method, cast on over these Ndles. with color 1. Knit 4 (6) rows setting Pat. on last row. Using TRUE REFLECTION SETTING same as BACK. With col. 1 & 2, knit to Row 80 (84). REMOVE ON WASTE YARN.

BUTTERFLY: Front Right Side.

USE NDLS. 1 to 28 (30) to the RIGHT OF 0. With W.Y. cast on 28 (30)sts. Work the waste knitting same as before ending with 1 row Ravel Cord to the right. With Col. 1, knit to Row 36 (42) setting Pat. 2 on last row. With Col.1 & 3, knit in Pattern. AT THE SAME TIME, on the RIGHT SIDE, increase 1 st. every 6th row 36 (38)x. After R 124 (130), begin Neck decreases. Dec. 1 st. every 3rd Row 34 (36)x. After Row 226 (238), bind off the remaining sts.

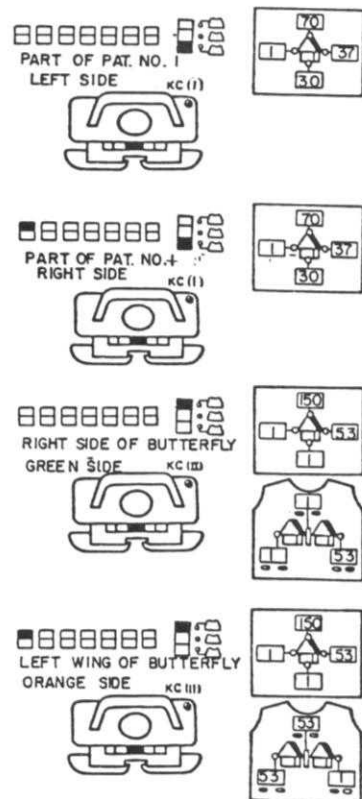

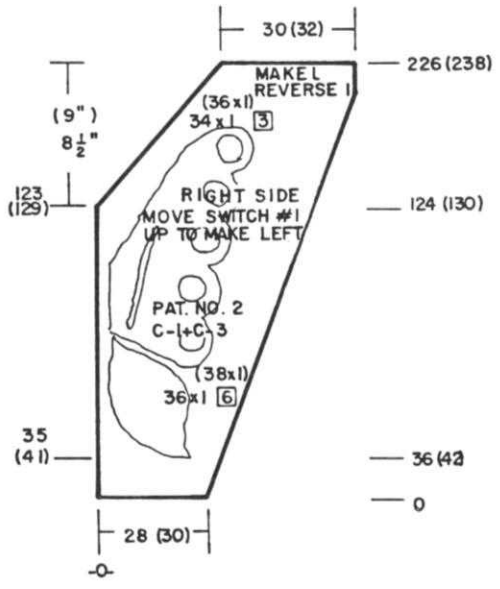
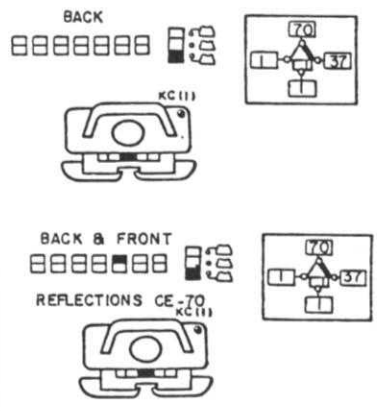

FINISHING:

Join Waistbands A & B together following diagram. Join the 2 sections of Butterfly down the center. Join Front Side Panels to sides of Butterfly.
Bring to WP 160 (180) Ndl. With right side facing, pick up open sts. of Waistband. With wrong side facing, hang lower edge of Front/Back onto these Ndl. Bind off. Close side seams. With 1 strand Col. 1, work 1 row slip stitch Crochet around neck edge then work 1 row with 1 strand Col. 3. With Col. 1, work 2 rows slip st. Crochet around lower edge. Make a small chain for Butterfly Antenna with color 3 and sew in place (see Picture).

BUTTERFLY: Front Left Side.

Using Ndl. 28 (30) to the LEFT of 0, make same as right side, being sure to follow Chart and REVERSE ALL SHAPINGS.

WAISTBAND: Make 2, REVERSE 2.

With W.Y. cast on 80 (90) sts. Work the waste knitting same as before ending with 1 row Ravel Cord to the right.
With Col. 1, knit 4 Rows, setting Fair Isle Pattern 1 on last row AND BE SURE TO NOTE THE SET LINE FOR THIS SECTION IS ON Row 30. SEE CHART. After Row 48, remove onto W.Y.
Make 1 more band the same as above, then make 2 reversing the Pattern (SEE CHART).

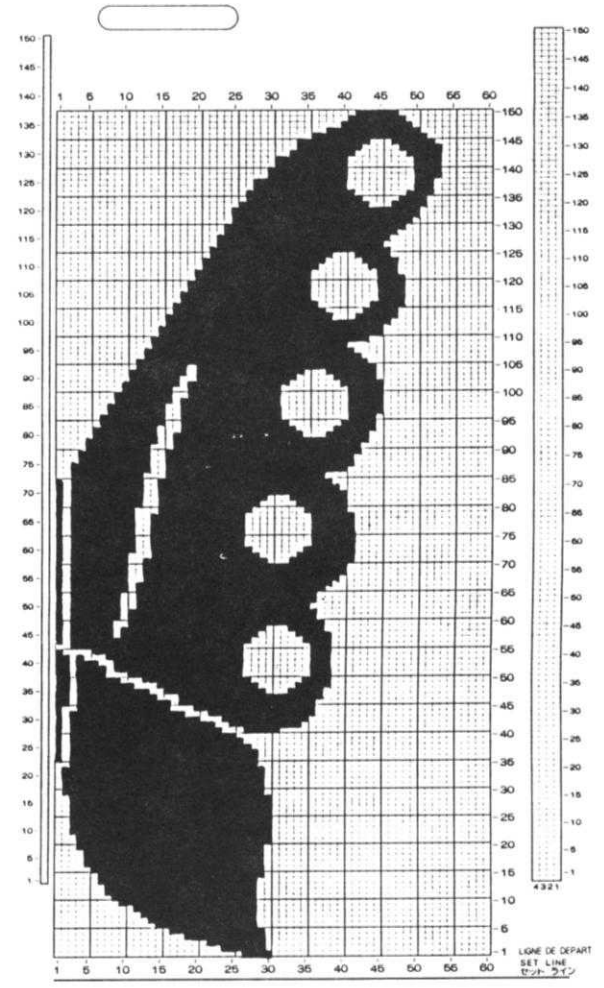
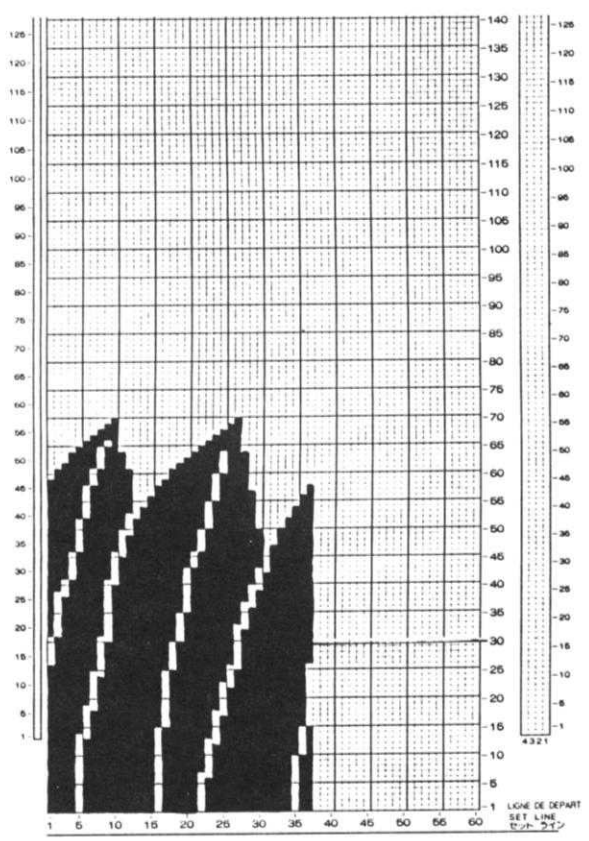
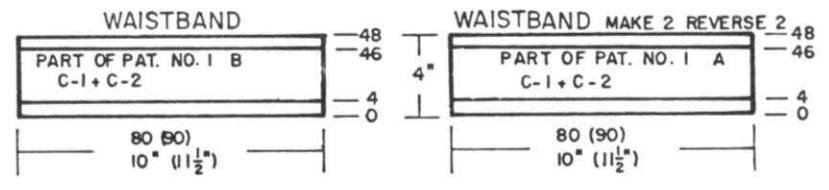

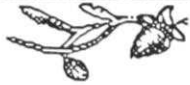

WOMENS DOLMAN SLEEVE BLOUSE and SKIRT with Kick Pleat.

SIZES: 8/10 (12/14) [16/18]

YARN: Fine Venetia = Col. 1

Acrylic Mohair = Co. 2, 3, 4

AMOUNT: Col. 1 2 lbs. all sizes

Col. 2, 3, 4, 2 oz. each for all sizes.

TENSION:

Blouse: T 4, Rib 0/0 I

Skirt: T 3

GAUGE: St. st. 17 sts. 26 Rows=2"

Tuck Pat. 16 sts. 39 Rows = 2"

Blouse is Stockinette st. Can be made on any Standard Machine. Skirt is TUCK PAT. Make it on any Punch Card machine. The Skirt is knitted sideways on machine using Color Changer. The Purl side of Skirt is the right side. Punch Card. 9 Covered Buttons. Elastic for Skirt waist.

SKIRT: Knitted Sideways.

With W.Y. cast on 188 (194) [200] sts. Knit several rows ending with 1 row Ravel Cord to the right. Counter 0, change to Col. 1. Knit St. st. After R 100, Set TUCK PAT and knit to R 496 (538) [582] being sure to NOT COLOR CHANGES AS SHOWN ON LEFT SIDE OF PUNCH CARD AND AT THE SAME TIME, on the LEFT EDGE, mark for waist after Rows 297 (319) [341]. Change to Col. 1 and continue in St. st. After R 596 (638) [682] Set Punch Card on 1 and continue in TUCK PAT. After R 992 (1076) [1164], pick up first row of St. held on W.Y. Knit 1 row the color 1 across all Ndl. Bind off.

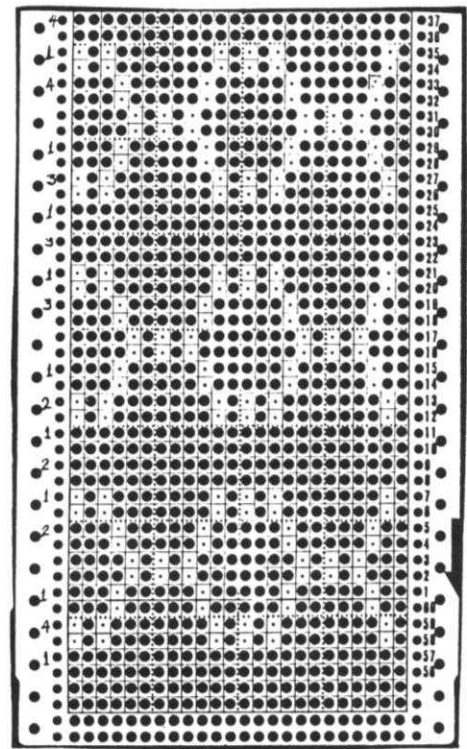

SKIRT WAISTBAND (Knit side) Make 2.

Bring to WP 148 (160) [172] Ndl. Using markers on Chart as guide, and with knit side facing you, hang the TUCK STITCH PORTIONS of 1/2. Skirt waist onto these Ndl. (DO NOT HANG the Stockinette section (this is for pleat). When the Tuck sections are on machine, make INVERTED PLEAT on stockinette section (to the right side) and hang the sts. onto the Ndl. Bring all Ndl. to HP. With Col. 1, 'e' cast on behind the latches. Carefully knit 1 row over all Ndl. Continue in St. st. BUT AT THE SAME TIME, ON EACH SIDE, decrease 1 st. every 8th row 8x. After R 63 (Carr on left), knit 1 Row T 10 to the right. Continue in St. St. (T 3) to Row 100. Pick up the sts. from loose row (T 10) to form hem. Bind off LOOSELY. REPEAT FOR SECOND HALF OF SKIRT.

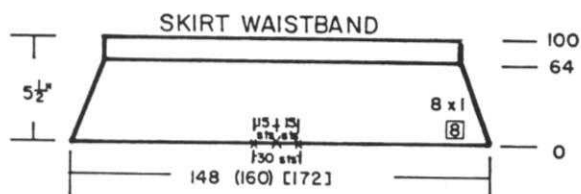
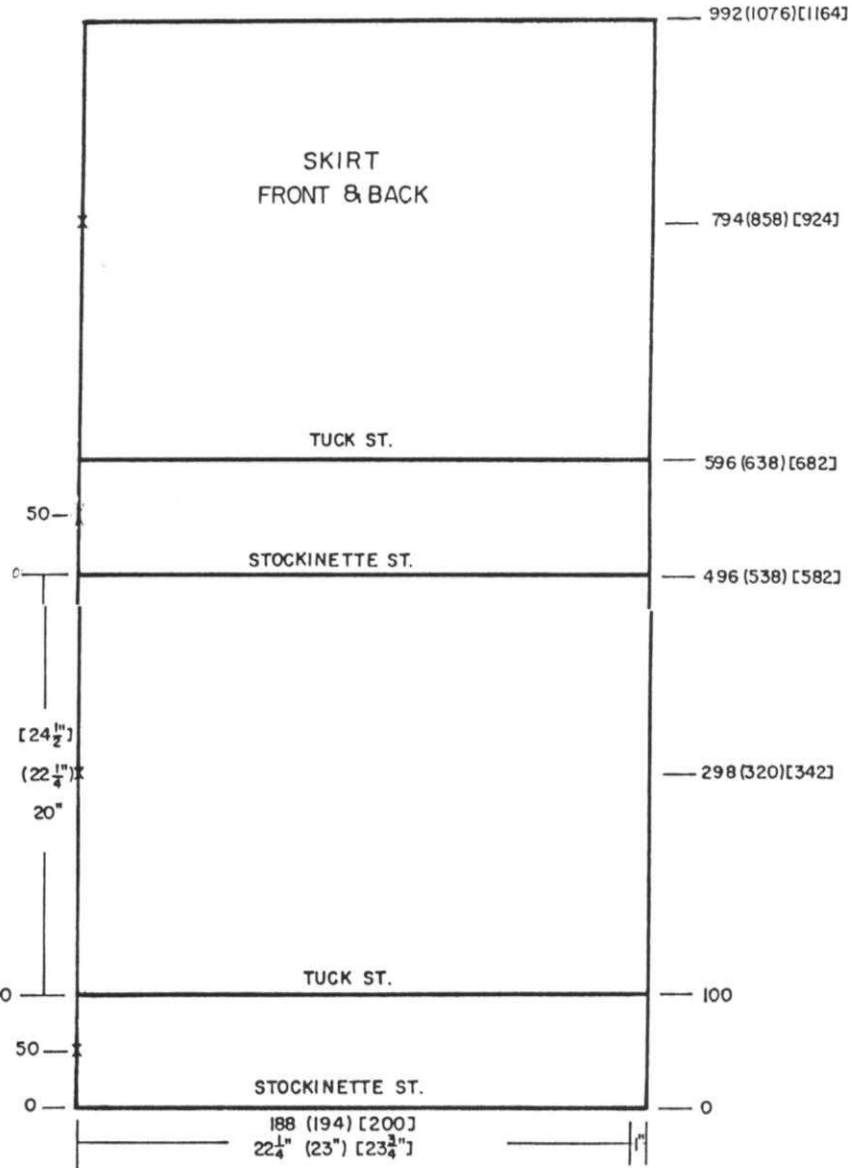

BLOUSE FRONT:

With W.Y. cast on 98 (100) [102] sts.
 After several rows end with 1 row
 Ravel Cord to the right. Change to
 Col. 1. Counter 0.
 Continue St. st. BUT AT THE SAME TIME,
 ON THE LEFT, inc. 1 st. EOR 49 (50)
 [51]x. After R 99 (101) [103], ON
 THE LEFT, cast on 39 (43) [47] sts.
 (See Chart). After R 196 (200) [208]
 ON NECK SIDE, dec. 1 st. EOR 19 (20)
 [21]x. After R 262 (270) [280], mark
 both ends for center of garment.
 After R 292 (300) [312], ON NECK SIDE,
 inc. 1 st. EOR 19 (20) [21]x.
 After R 425 (441) [457], ON LEFT
 SIDE, bind off 39 (43) [47] sts.
 then on EOR dec. 1 st. 49 (50) [51]x.
 After R 524 (542) [560], bind off.

BLOUSE BACK: Make 1, reverse 1

Cast on same as front and knit to
 R 196 (200) [208].
 SHAPE NECK: Dec. 1 st. EVERY ROW
 62 (66) [70]x.
 After R 260 (268) [280], bind off
 remaining sts.

SLEEVE BANDS: Make 2.

CLOSE BOTH SHOULDERS FIRST
 K1, P1 Rib: With Col. 1, cast on
 97 (99) [101] sts.
 Knit 36 rows. Transfer Rib sts. to
 MB. Pick up sts. of first row to
 form hem. With WRONG SIDE FACING,
 hang open sts. of sleeve, doubling
 sts. across. Bind off LOOSELY.
 REPEAT for other sleeve.

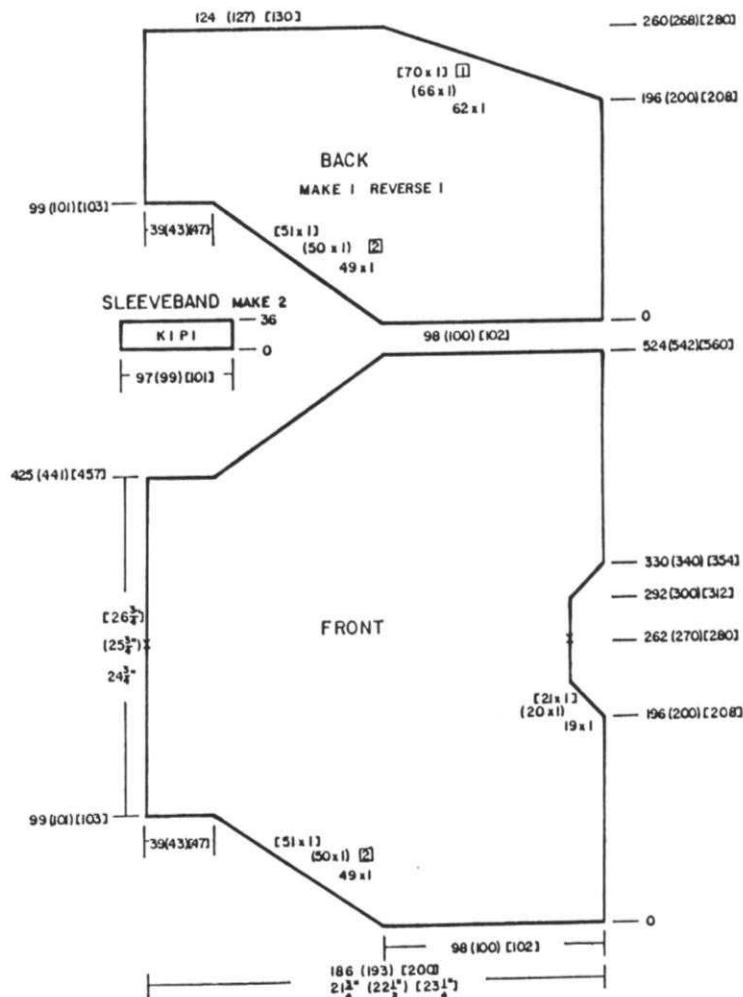

BLOUSE WAIST BAND: Make 2.

K1, P1 Rib: Cast on 151 (159) [167]
 sts. Knit 100 rows. Transfer Rib
 sts. to MB. Pick up first row to
 form hem (same as sleeve band).
 Close side seams of Blouse.
 With wrong side facing, hang 1/2
 of waist edge onto these Ndls.
 (Waistbands join at center front).
 REPEAT for second band.

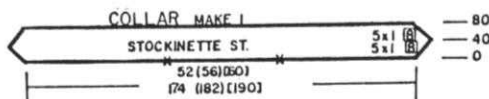
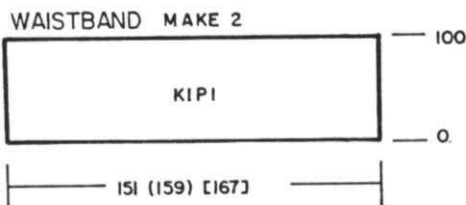

COLLAR: Make 1

W.Y. cast on 174 (182) [190] sts.
 After several rows end with 1 row
 Ravel Cord to the right.
 Counter 0, change to Col. 1.
 Knit St. st. AND ON EACH SIDE,
 inc. 1 st. every 8th row 5x.
 After R 40, ON EACH SIDE, dec.
 1 st. every 8th row 5x. After
 R 80, pick up first row to
 form hem. Mark the center
 52 (56) [60] sts. with W.Y.
 (See Chart). With wrong side
 facing, hang neck edge of Blouse
 onto these Ndls. Be sure the
 marked sts. meet at the shoulder
 seam. Bind off.

**BACK BANDS: Make 2, one without
 Buttonholes.**

W.Y. Cast on 147 (150) [153] sts.
 After several rows, end with 1 row
 Ravel Cord to the right.
 Change to Col. 1. Counter 0.
 Knit St. st. to R 10. Make BUTTON-
 HOLES (See Chart for Needle selection
 and distance between buttonholes).
 Knit to R 30. REPEAT BUTTONHOLES
 over same Ndls as before. After
 R 40, hang hem.
 With Wrong side Facing hang lower
 section of back opening onto these
 Ndls. Plus the edge of the Waist
 Band. (On chart this is section
 Marked 124 (127) [130]).
 Bind off loosely.
 Repeat for other side of back
 opening.

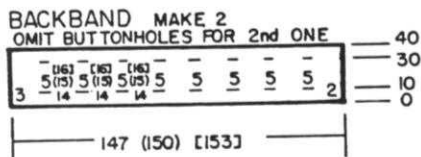

FINISHING:

See General Instructions.
 Insert Elastic thru casing
 at skirt waist. Make
 hem at lower edge of Skirt.
 On the right side, close
 inverted pleats to approxi-
 mately 9 inches from lower
 edge. Sew on Buttons and
 finish buttonholes.

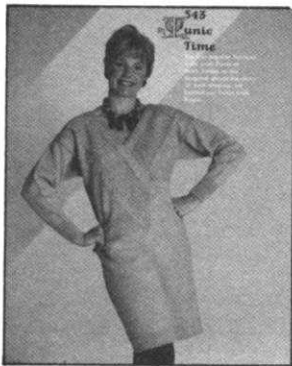

WOMENS TUNIC

SIZES: 8/10 (12/14)
 YARN: Regia
 AMOUNT: 13 14 Balls
 TENSION: 7 Rib 3/3 I
 GAUGE: 15 sts. 20 R = 2" (5 cm)

Knit on any Standard Machine with Ribber. The front neckline is filled in with special bands that include Cables. Waistbands and Neckbands are K2, P1 Ribbing. Sleeve bands are K1, P1 Ribbing.

BACK:

K2, P1 Rib: Cast on 194 (200) sts. Knit 23 rows. Transfer Rib sts. to MB. Knit 1 row to the right then remove on W.Y. Bring into WP 146 (154) Ndl. Hang the ribbing onto these Ndl. decreasing evenly across. COUNTER AT 0. Continue in St. st. to R 268 (272). Mark each side with W.Y. After R 360 (370), ON EACH SIDE, bind off 46 (48) sts. Knit to R 374 (384) BUT AT THE SAME TIME, increase 1 st. EACH SIDE EVERY ROW 12x. After R 374 (384), bind off.

FRONT:

Work same as Back to R 140 (150). Divide in center, put Ndl. on the left into HP and complete right side first. *ON NECK SIDE, decrease 1 st. every 3rd row 73x. After Row 268 (272), mark with waste yarn. After R 360 (370), bind off. Bring the Ndl. on left into WP, COUNTER 140 (150) and complete left half. Follow instructions from *.

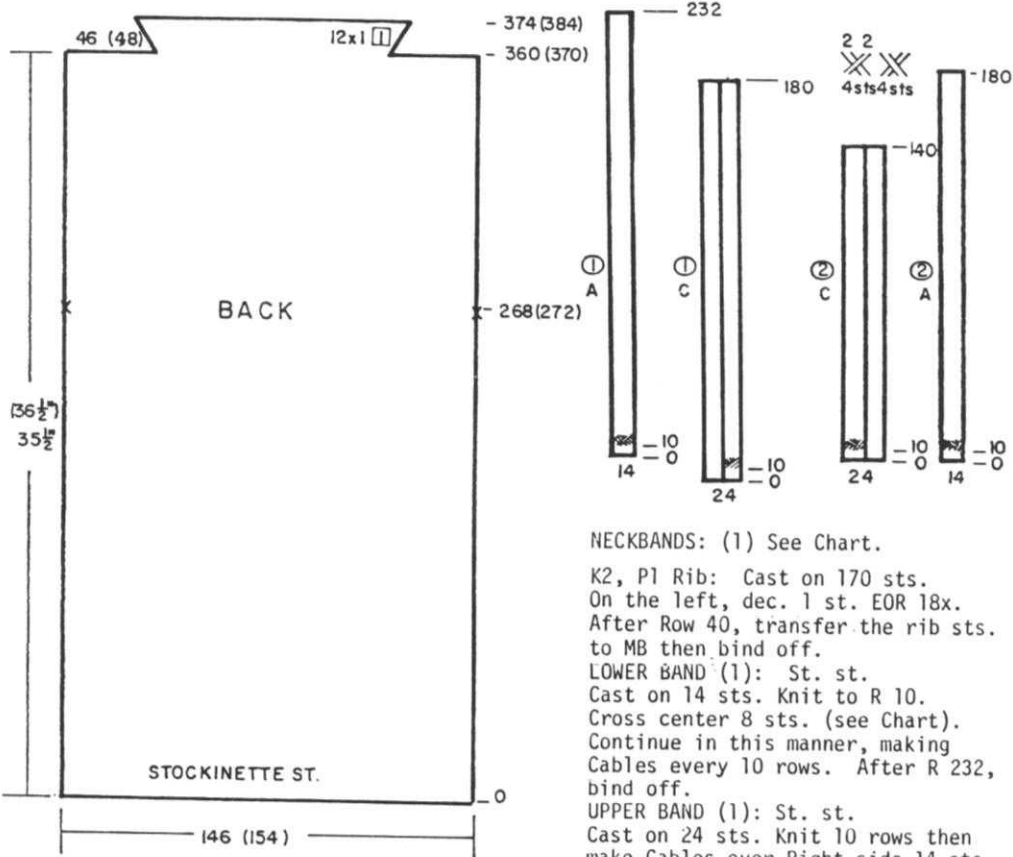

NECKBANDS: (1) See Chart.

K2, P1 Rib: Cast on 170 sts. On the left, dec. 1 st. EOR 18x. After Row 40, transfer the rib sts. to MB then bind off.

LOWER BAND (1): St. st. Cast on 14 sts. Knit to R 10. Cross center 8 sts. (see Chart). Continue in this manner, making Cables every 10 rows. After R 232, bind off.

UPPER BAND (1): St. st. Cast on 24 sts. Knit 10 rows then make Cables over Right side 14 sts. Cross the center 8 sts. same as lower band. Continue making Cables every 10 rows. After R 180, bind off.

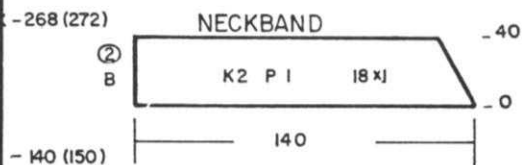
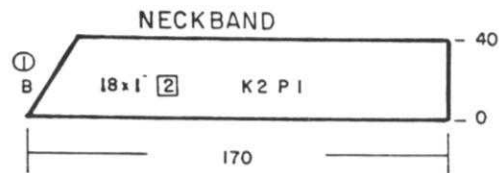
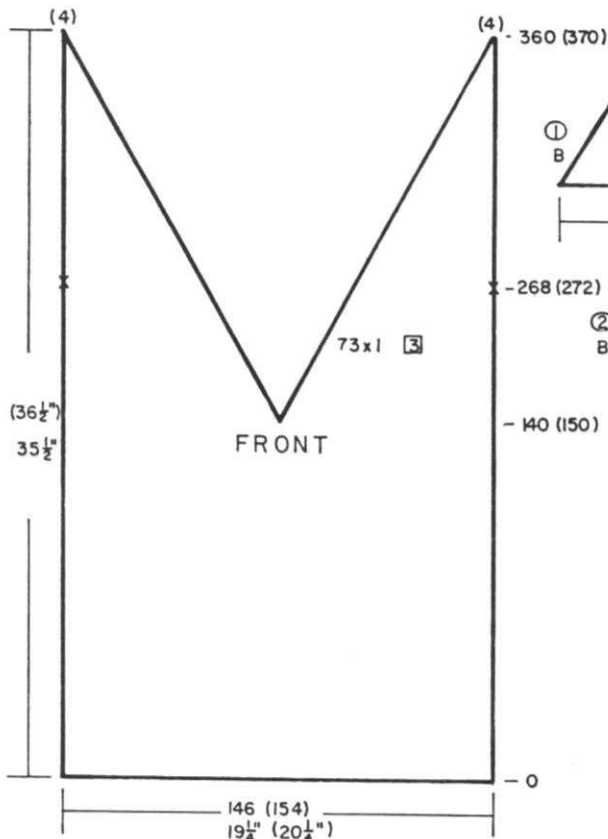
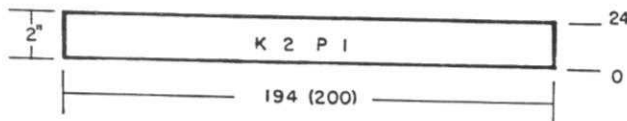

NECKBANDS: (2) See Chart.

K2 P1 Rib. Cast on 140 sts. ON RIGHT SIDE, dec. 1 st. EOR 18x. After R 40, bind off. LOWER BAND (2) St. st. Cast on 14 sts. Knit 10 rows. Cross Cables over center 8 sts. same as lower band (1). Continue in St. st. making Cables every 10 rows. After R 180, bind off. UPPER BAND (2): St. st. Cast on 24 sts. Knit 10 rows. Make Cables over LEFT 14 sts. (cross center 8 sts.). Continue making Cables every 10 rows. After R 140, bind off.

SLEEVES:

K1, P1 Rib: Cast on 71 (77) sts. After R 44, transfer Rib sts. to MB. Add 1 st. on right. ON EACH SIDE, increase 1 st. every 4th row 37 (38)x. After R 196 (200) mark center with W.Y. and bind off.

FINISHING:

Join bands marked (1) on Charts together. Join bands marked (2) on Charts together (SEE PICTURE). Fold 10 sts. from 24 st. strip to the inside to form hem. After joining pieces, attach longer section to the right side of V Neckline. Attach the SHORTER section to the LEFT side of V Neckline. Join shoulders. Fold Neck Facing to the inside and secure. Join sleeves. Close side seams. Insert thread through neck opening for a firm edge and to prevent sag.

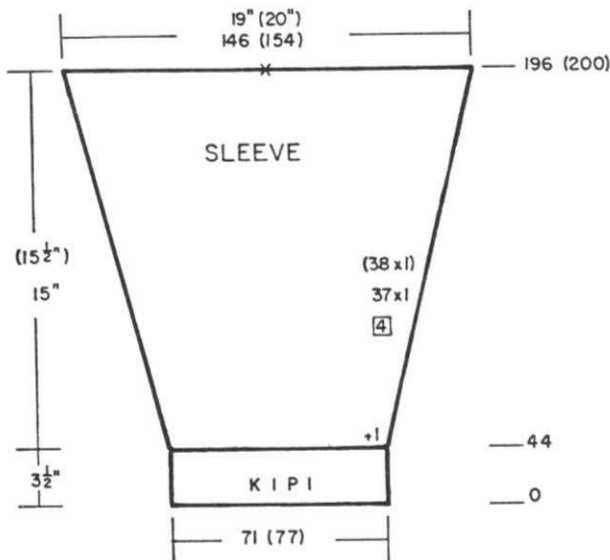

544



WOMENS DRESS & JACKET

SIZES: 6/8 (10/12)

YARN: Venetia

AMOUNT:

- Col. 1 1 lb. 2 oz. 1 lb. 4 oz.
- Col. 2 1 lb. 10 oz. 1 lb. 12 oz.
- Col. 3 Small amount (1 oz)
- Col. 4 Small amount (1 oz)

TENSION: St. st. 4, FNR 2/2 I

K1, P1 Rib. 4/4 II

GAUGE: St. st. 17 sts. 28 Rows = 2"

Lace 17 sts. 27 Rows = 2"

Make on any Standard Machine with Ribber. Punch Card for Lace Pattern.

DRESS BACK:

FNR: With color 1, cast on 160 (170) sts. Knit 12 rows. Transfer Rib sts. to MB.

Change Tension and continue in St. st. to R 300 ON EACH SIDE, decrease 1 st. every 10th row 9 (10)x.

After R 400 (410), transfer every other st. to Ribber for K1, P1. Add weights, change Tension. ON EACH SIDE, increase 1 st. every 10th row 9 (10)x.

After R 510 (526), transfer rib sts. to MB. Bind off.

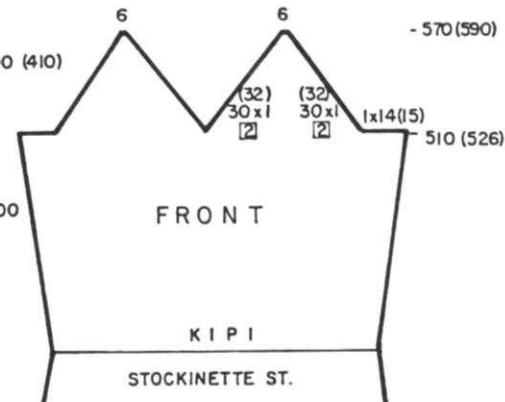
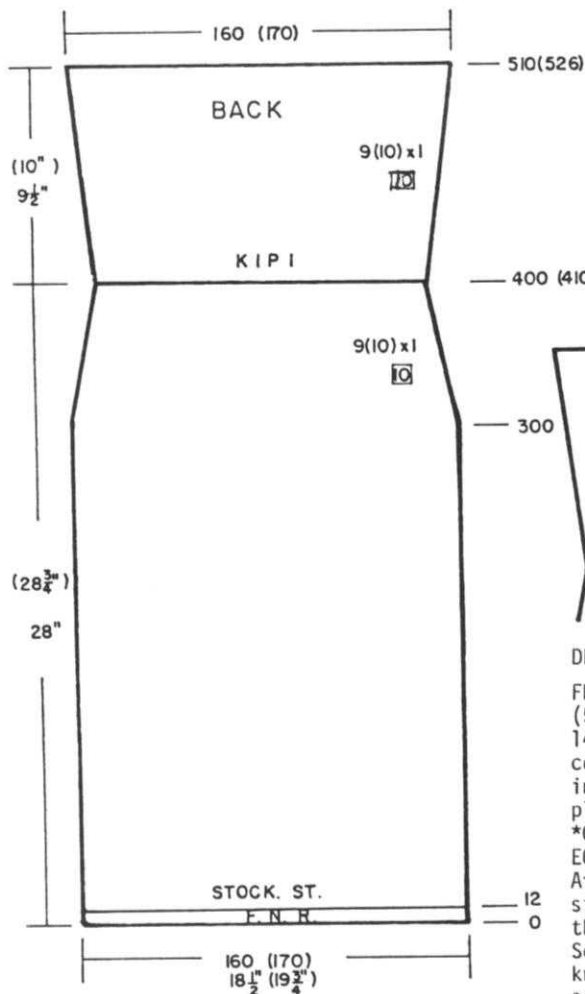

DRESS FRONT: - Col. 1

FNR: same as Back to R 510 (526). ON EACH SIDE, bind off 14 (15) sts. Divide work in center. Put the Ndl's. on left into holding position and complete the right side first. *ON EACH SIDE, decrease 1 st. EOR 30 (32)x.

After R 570 (590), transfer rib sts. to MB. Knit 1 row over the sts. Reduce to 4 sts. Set machine for knitting a cord and knit approximately 11" to be used as shoulder strap. Bind off. Bring sts. on left back to WP. Turn Row Counter to 510 (526) and complete left half. Follow instructions from *.

FINISHING:

Weave or sew side seams. Anchor shoulder strap on back.



CONTINUED NEXT PAGE

SPECIAL INSTRUCTIONS FOR LACE JACKET

One complete Pattern ends on R 60 of the Card - so STOP the Card. Then completes 20 (22) rows of St. st. Before starting next Lace Pattern, manually advance Card to Line 1. REPEAT THROUGHOUT.

LACE JACKET - Make 1, reverse 1.

Knitted sideways on the machine. With W.Y. cast on 179 (185) sts. After several rows end with 1 row Ravel Cord to the RIGHT. Counter 0, change to Col. 2. Knit 10 (12) rows St. st. then continue in Lace Pattern. After R 20 (22), SHAPE NECK ON THE RIGHT. Inc. 1 st. EOR 15 (16)x. Continue in Lace Pattern. After R 118 (126), ON THE RIGHT LOOSELY BIND OFF 95 (100) sts. then from LEFT to RIGHT 'e' cast on over the same empty Ndl's. the 95 (100) sts. Bring these Ndl's. to E position and CAREFULLY knit the next row. Hang a cast on Comb or some type of weight on these new sts and continue in Lace Pat. After R 186 (198), ON THE RIGHT, DECREASE 2 STS. EVERY ROW 50 (54)x. After R 236 (252), bind off LOOSELY. Make 2nd section with REVERSE SHAPING.

SLEEVES:

With W.Y. cast on 190 (200) sts. After several rows end with 1 row Ravel Cord to the right. Counter 0, change to Col. 2. Knit 2 rows then begin Lace Pat. Knit to R 184 (190). MARK CENTER OF SLEEVE, then remove onto W.Y.

SLEEVE TRIM: MAKE 2 COL. 4

With W.Y. cast on 190 (200) sts. same as you did for sleeves. After Ravel Cord row, change to Col 4. Counter 0. Continue in St. st. to R 40. Pick up the first row to form hem. Carefully remove W.Y. Knit 1 row over doubled sts. Bind off LOOSELY BEHIND THE GATE PEGS. (MARK CENTER)

SLEEVE TRIM: MAKE 2 Col. 3

With W.Y. cast on 170 (180) sts. same as you did for Col. 4 trim. Change to Col. 3 and knit 80 rows St. st. Pick up first row to form hem and complete same as for Col. 4 Trim.

SLEEVE TRIM: Make 2 Col. 1

With W.Y. cast on 150 (160) sts. same as other trims. With Col 1, Knit to R 120. Pick up first row to form Hem and complete same as other trims.

SLEEVE TRIM MAKE 2

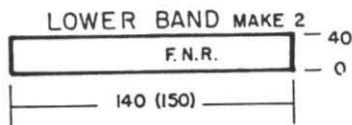
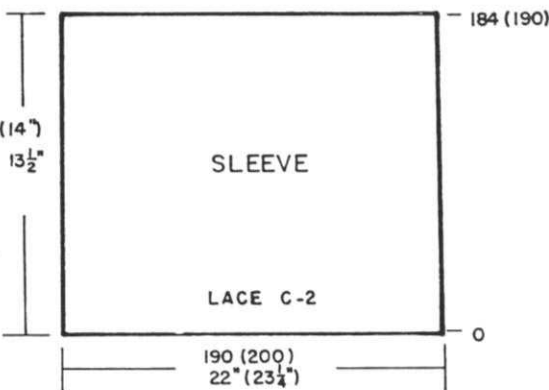
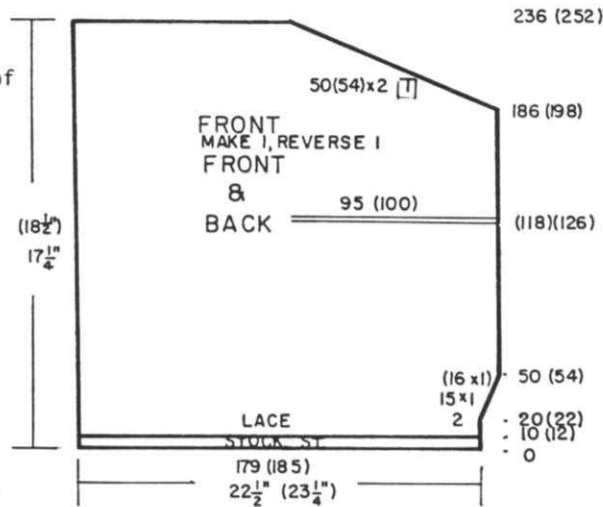
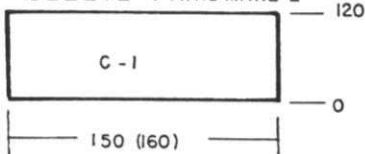

LOWER BANDS FOR JACKET: Make 2.

FNR: Cast on 140 (150) sts. with Col. 2. Knit 40 rows. Transfer Rib sts. to MB. With wrong side facing, hang lower edge of 1 section of Jacket onto these Ndl's. (Jacket is joined at center back). Bind off. REPEAT for 2nd section).

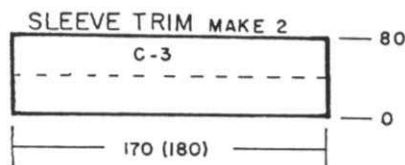
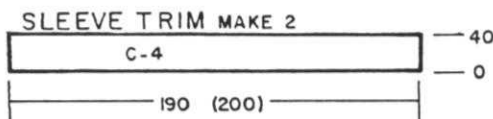

236 (252)

186 (198)

(118)(126)

50 (54)

20 (22)

10 (12)

0

184 (190)

0

40

0

40

0

126 (134)

20

0

186 (200)

0

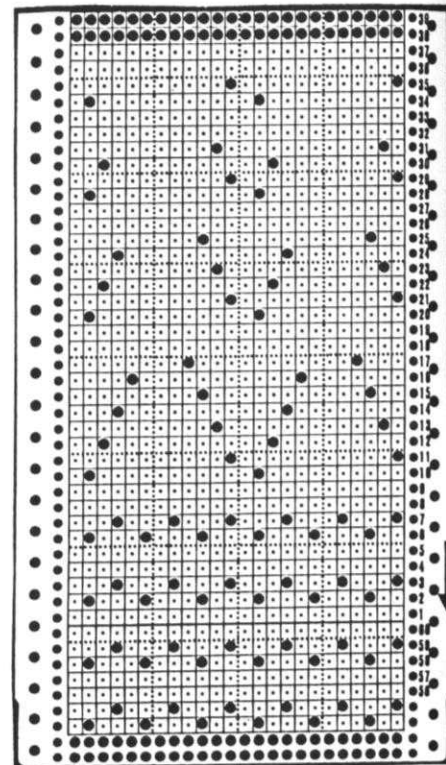

CHART

ST. ST.	20(22)R
LACE	16R
	0

SLEEVE BANDS: Make 2.

With W.Y. cast on 126 (134) sts. After several rows, end with 1 row Ravel Cord to the right. Counter U, change to Col. 1. Knit St. st. to R 40. Pick up first row to form hem. Carefully remove waste yarn. With wrong side facing, hang lower edge of sleeve onto these Ndl's. decreasing evenly across. Carefully bind off.

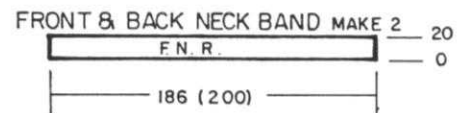
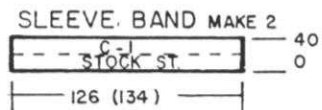

FRONT and 1/2 of BACK, NECKBAND: MAKE 2.

FNR: With Col. 2, cast on 186 (200) sts. After selvedge, knit to R 20. Transfer Rib sts. to MB. Remove on W.Y.

FINISHING:

Weave the 2 sections of Jacket down the center back. Close both shoulders.
 With **RIGHT SIDE FACING**, start at shoulder seam and hang 1/2 of sleeve opening onto 95 (100) Ndl. then hang 1/2 of Col 4 Sleeve Trim onto these same Ndl. Take Col 3 Sleeve Trim, locate center and again starting at Shoulder, hang the sts. onto Ndl in the same way.

Take Col. 1 Sleeve trim and locate the center and hang onto Ndl same as before. You now have several layers of knitting ALL on the same Ndl. The Carriage WILL NOT BE ABLE to knit across, SO CAREFULLY knit 1 row manually. (Bring Ndl. to E position, hook yarn over needle hook and push back to B position - Knit each st. in

this way After knitting the row manually. With **WRONG SIDE FACING**, hang 1/2 of TOP EDGE of Sleeve onto the same Ndl. Bind off LOOSELY. Bring 95 (100) Ndl. to WP and REPEAT ENTIRE PROCEDURE to attach second half of sleeve trim and sleeve. Follow General Instructions for the remainder of the finishing.

545



WOMENS DRESS

SIZES: 8/10 (12/14) [16]
YARN: Venetia
AMOUNT: 2 lbs. 2 lbs. 2 lbs.6 oz.
TENSION: 3/3 I for Dress
 4/4 II for bottom of Dress, Sleeves, and Collar.
GAUGE: 14 sts. 22 rows = 2" (5 cm)
 Make on any standard Machine with Ribber. Entire Dress is knitted in FULL NEEDLE RIBBING.

FRONT:

Work the front same as back to R 430 (440) [450]. Bind off the center 38 (42) [46] sts. (Transfer to MB first, then bind off). Put Ndl. on left into HP and complete the right side first.
 *Knit to R458 (470) [482]. Transfer the Ribber sts. to MB and bind off.
 Bring Ndl. on left to WP Turn Row Counter back to 430 (440) [450] and complete left half. Follow Instructions from *.

BACK:

FNR: Cast on 142 (150) [158] sts. After completing selvedge with T 4/4 II knit 10 rows. Change to T 3/3 I. ON EACH SIDE, decrease 1 st. every 50 rows 3x. After R 240 (246) [252], ON EACH SIDE, decrease 1 st. every 6th row 5x.

After R 276 (282) [288], ON EACH SIDE, INCREASE 1 st. every 6th row 5x. After R 364 (370) [376], mark each side with W.Y. for setting in sleeves.. After R 458 (470) [482] transfer the Ribber sts. to MB. Mark each side for Neck then bind off.

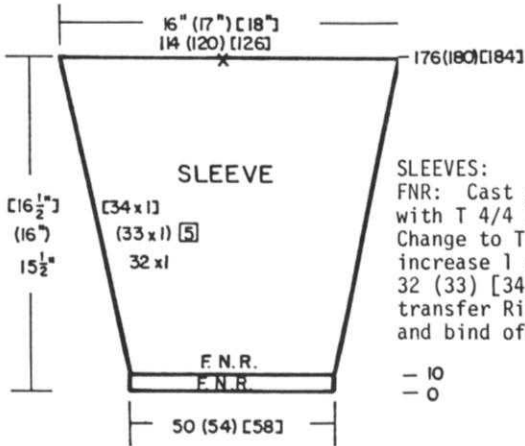

SLEEVES:
 FNR: Cast on 50 (54) [58] sts. with T 4/4 II, knit to Row 10. Change to T 3/3 I. ON EACH SIDE, increase 1 st. every 5th row 32 (33) [34]x. After R 176 (180) [184] transfer Ribber sts. to MB and bind off.

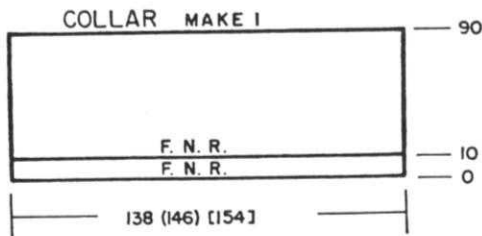

COLLAR: Make 1

FNR: Cast on 138 (146) [154] sts. With T 4/4 II, knit 10 rows. Change to T 3/3 I and knit to R 90. Transfer Ribber sts. to MB and bind off.

FINISHING:

See General Instructions.

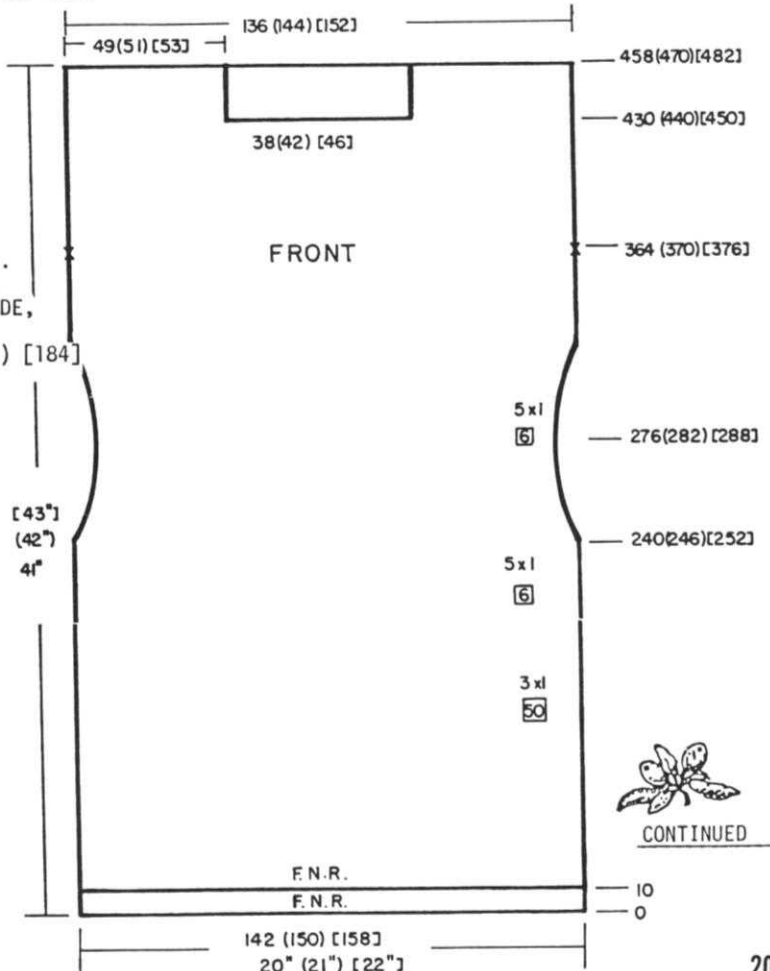

CONTINUED

WOMENS COAT

SIZES: 8/10 (12/14) [16]
 YARN: Venetia
 AMOUNT: 1 3/4 lbs. 2 lbs. 2 lbs.6 oz.
 TENSION: 3/3 I - Rib. Trim 4/3 II
 GAUGE: 14 sts. 21 1/2 Rows = 2"

Knit on any Standard Machine with Ribber. Entire garment is FULL NEEDLE RIBBING.

BACK:

FNR: Cast on 140 (150) [160] sts. After knitting selvedge, change to Ten. 3/3 I and knit to R 100. ON EACH SIDE, dec. 1 st. and mark each side with W.Y. Knit to R 200. ON EACH SIDE, dec. 1 st. After Row 316 (322) [328], mark each side with W.Y. for setting in sleeves. Knit to R 418 (430) [442]. ON EACH SIDE, mark the center neck opening with W.Y. as shown on Chart. Trans. Rib sts. to MB. Bind off.

FRONT: Make 1, reverse 1.

FNR: Cast on 70 (75) [80] sts. After selvedge, change tension and knit to R 100. ON THE RIGHT (left) dec. 1 st. Knit to R 190. Mark each side with W.Y. for placement of Pocket (see Chart). Knit to R 200. ON THE RIGHT (left) dec. 1 st. Knit to R 316 (322) [328]. Mark RIGHT (left) edge for setting in sleeve. Knit to R 358 (364) [370]. SHAPE FRONT: ON LEFT (right) dec. 1 st. every 3rd row 20 (22) [24]x. Knit to R 418 (430) [442]. Trans. Rib sts. to MB. Bind off.

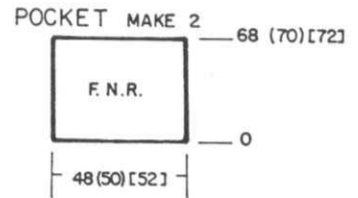
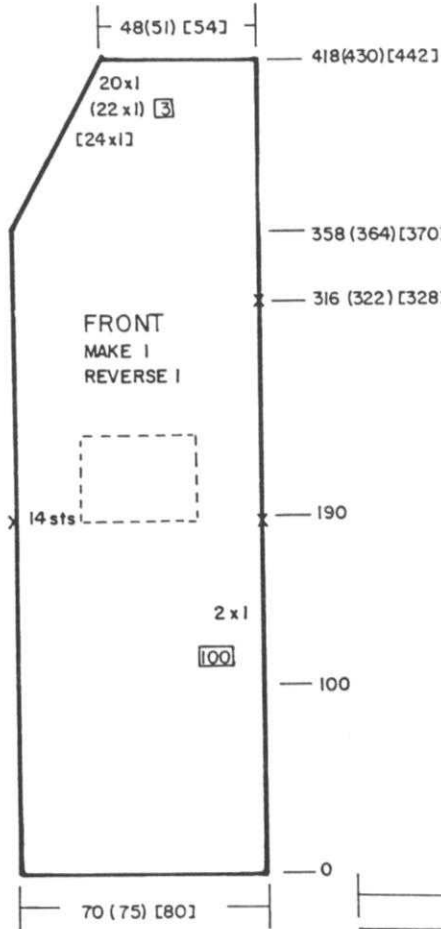

POCKETS: Make 2

FNR: Cast on 48 (50) [52] sts. With Tension 3/3 I, knit to R 68 (70) [72]. Transfer Rib sts. to MB. Bind off.

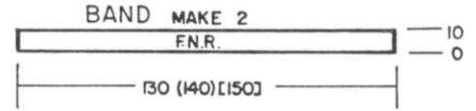

LOWER BANDS: Make 2

FNR: Cast on 130 (140) [150] sts. Work the same as UPPER BANDS.

SLEEVES:

FNR: Cast on 92 (98) [104] sts. After selvedge, change tension. ON EACH SIDE, increase 1 st. every 6th row 20 (21) [22]x. After R 126 (132) [138], transfer Rib sts. to MB. Bind off.

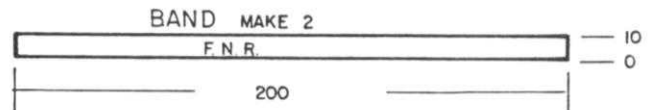
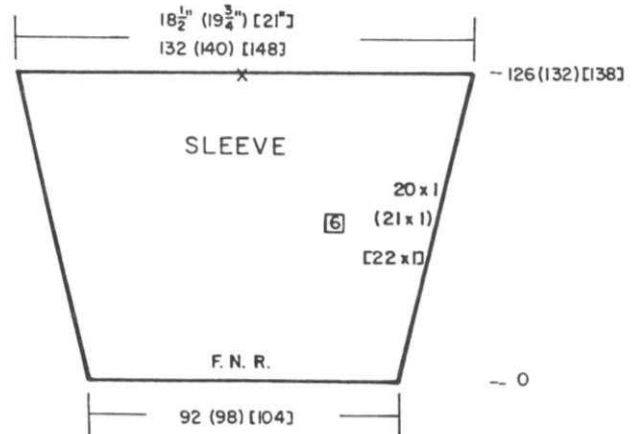

FRONT & NECK BANDS:
 UPPER BANDS: Make 2

FNR: Cast on 200 sts. With Tension 4/3 II, knit 10 rows. Transfer Rib sts. to MB. Knit 1 row St. st. over all sts. to the left. Remove on W.Y.

FINISHING: See General Instructions. Join bands and attach to front and neck edge with seam at center back. Work 1 row single crochet around slit opening. Sew pockets in place.

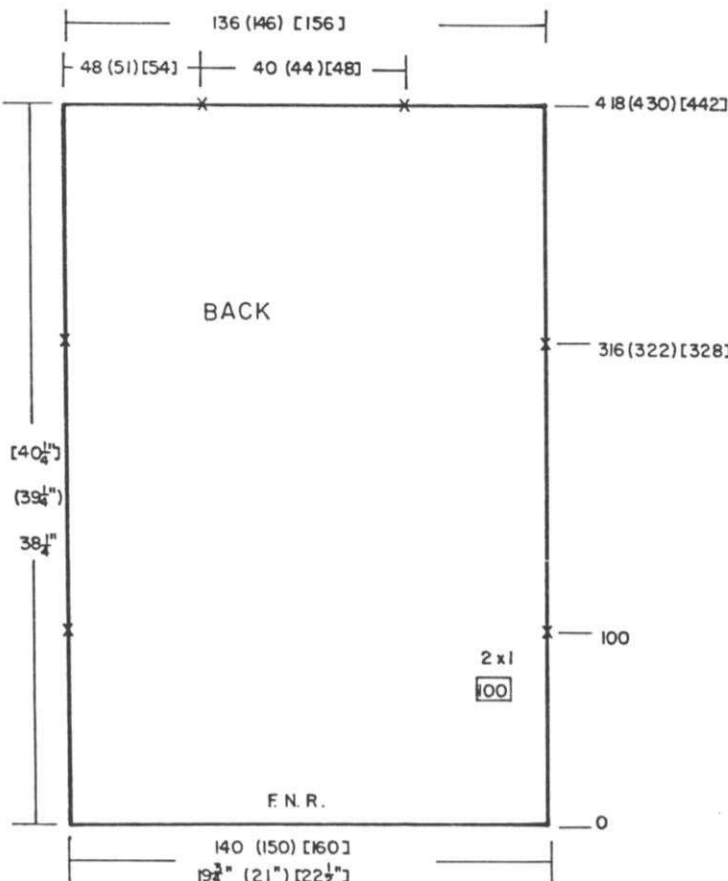



WOMENS DRESS

SIZES: 6/8 (10/12) [14/16]
YARN: Roma
AMOUNT: 2 lbs. all sizes.
TENSION: 4 St. st. - 5 Lace
 5/5 II Ribbing
GAUGE: 16 sts. 21 rows = 2"

Can be made on any Electronic Machine with Ribber. Bottom of Skirt, Shawl Collar and Sleeve Cuffs are Lace. Draw on Mylar Sheet.

TOP: MAKE TOP FIRST. BACK & FRONT.

With W.Y. cast on 180 (190) [200] sts. Knit several rows ending with 1 row Ravel Cord to the right. Change to garment yarn. Counter 0. Continue in St. st.. ON EACH SIDE, decrease 1 st. every 6th Row 15x. After R 126 (130) [134], SHAPE ARMHOLE: SEE CHART FOR DECREASES. After Row 196 (200) [204], SHAPE NECK: Bind off center 60 (62) [64] sts. put the needles on the left into HP and complete right side first.
 *ON NECK EDGE, dec. 1 st. every 2nd Row 4 (5) [6]x. After R 208 (214) [220]. Bind off. Bring the needles on left into WP, Row Counter 196 (200) [204] and complete left half. Follow instructions from *.

SKIRT: Make 4 Panels.

W.Y. cast on same way as you did for Top. After Ravel Cord Row, change to garment yarn and crochet cast on over these needles BEHIND THE LATCHES (bring needles to HP first to make it easy for you). Counter 0. Knit 2 rows then begin LACE PATTERN.

After R 40, continue in St. St. After R 294 (300) [306] remove on W.Y. Join 2 Panels for Front/Back.

WAISTBAND: Make 2

FNR: CO 110 (120) 130] Sts. Knit 20 rows. Transfer Rib sts. to MB. With wrong side facing, hang the lower edge of TOP onto these Ndl's. Decrease across by doubling the center 28 sts. then ON EACH SIDE, decrease evenly (approx. 2 sts. every 2nd needle). Bind off. Bring into W.P. 120 Ndl's. Hang the BOTTOM SIDE OF WAISTBAND onto these Ndl's, then hang top edge of Skirt onto same Ndl's., decreasing evenly across. Bind off.

SHAWL COLLAR: Make 2.

Cast on same as Skirt bottom, 134 (142) [150] sts. Knit in Lace Pattern. ON EACH SIDE, decrease 1 st. EOR 15x. After R 30, change to St. st. Knit to R 96. SHAPE NECK SAME as TOP (See Chart). After R 108 (110) [112], bind off.

SIDE PANELS FOR COLLAR: Make 2.

Cast on same as Skirt bottom, 167 (170) [173] sts. Knit in Lace Pattern. ON EACH SIDE, dec. 1 st. EOR 15x. After R 30, knit 2 rows St. st. then bind off or remove onto W.Y.

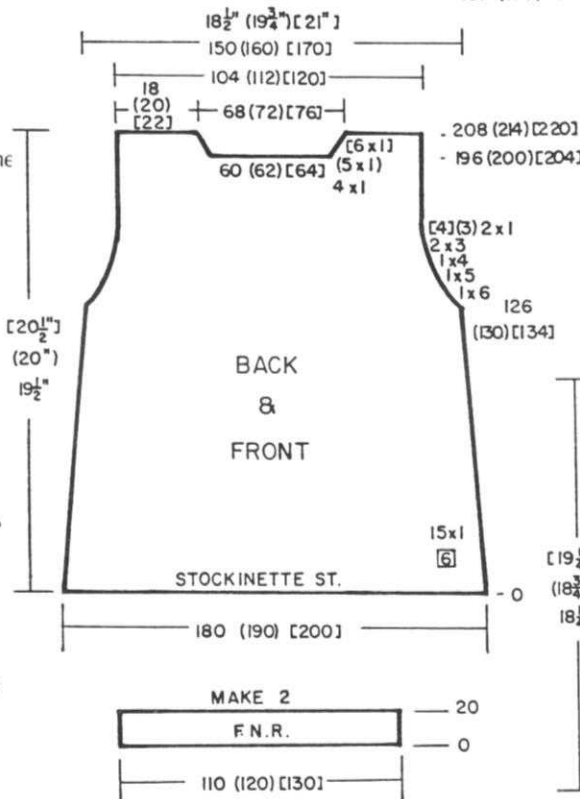
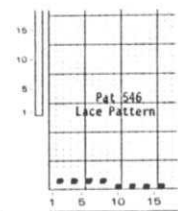
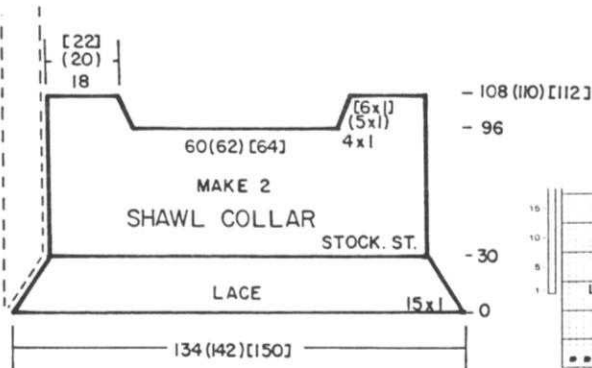

SLEEVES:

With W.Y. cast on 140 (150) [160] sts. same as you did for Top. After Ravel Cord row, continue in St. st. to Row 112 (114) [116]. Begin decreases ON EACH SIDE for Cap Shaping. (SEE CHART). After Row 194 (200) [206], bind off the remaining sts.

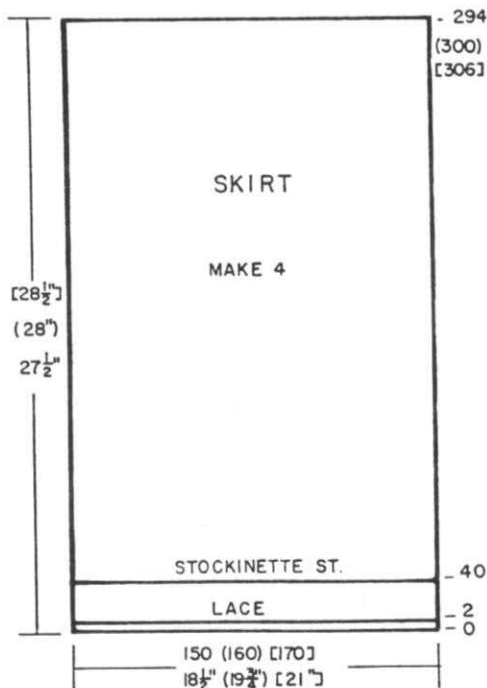
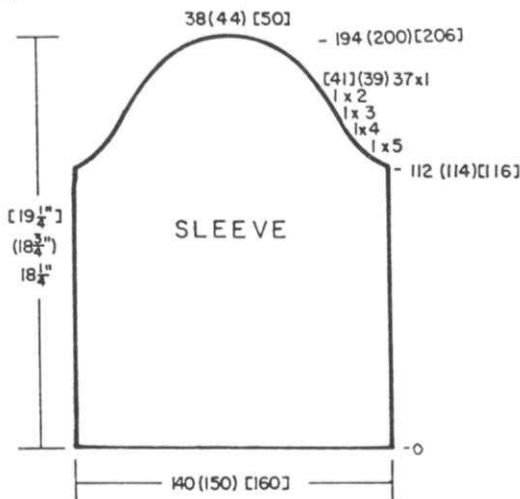

SLEEVE CUFF:

Use same method as for Skirt and cast on 72 (79) [86] sts. Knit in Lace to Row 30. Change to St. st. and knit to R 50. Remove onto W.Y. Bring 72 (79) [86] Ndl's. to W.P. With RIGHT SIDE FACING, hang bottom of Sleeve onto same Ndl's. Bind off.

FINISHING:

See General Instructions. Close shoulders of Top. Close both shoulder seams of Shawl Collar. Place Collar over top, Matching neck opening. Attach Collar to Top with 2 rows single crochet. Join side seams. Set in Sleeves Baste Elastic around inside on Sleeve cuff and waist.



WOMENS 2 PIECE DRESS WITH LACE PETTICOAT.

SIZES: 6/8 (10/12) [14/16]

YARN: Venetia = Color 1
Roma = Color 2

AMOUNT:

Col. 1 2 lbs. for all sizes.
Col. 2 1 lb. Cone

TENSION: See Instructions.

GAUGE: Venetia - 15 sts. 25 Rows = 2"
Roma - 13 sts. 23 Rows = 2"

3 Buttons - Approx. 2 cm (Optional)
Large Sequins (Optional)

Make on any Standard Punch Card or Electronic machine with Ribber. Stockinette stitch and Lace. Knitted sideways on the machine. Bands are FULL NEEDLE RIBBING.

TOP BACK: Tension 4.2

With W.Y. cast on 33 (36) [39] sts. Knit several rows ending with 1 row Ravel Cord to the right. Counter 0, change to Col. 1 and continue in St. st. AT THE SAME TIME, on the RIGHT, inc. 1 st. every 10th row 25 (26) [27] x AND ON THE LEFT, inc. 1 st. every 10th row 17 (18) [19]x. After R 180 (186) [193], on the LEFT, inc. 2 sts. 4x. EOR. After R 190 (196) [202], ON THE LEFT, cast on 91 (92) [93] sts. Continue in St. st. remembering to continue the increases on the right. After R 260 (270) [280] SHAPE NECK: Dec. 1 st. EOR 10x. Mark R 314 (330) [342] for center of garment. FOLLOW CHART for 2nd half, REVERSING SHAPING. After R 630 (658) [686], remove on W.Y.

FRONT: Tension 4.2

Work same as back to R 260 (270) [280]. SHAPE FRONT NECK: Dec. 1 st. EOR 15x. After R 340 (358) [376], INCREASE 1 st. EOR 15x. Continue same as Back. After R 630 (658) [686] remove on W.Y.

NECKBAND: Tension 4/4 II

FNR: Cast on 140 (150) [160] sts. Knit 10 rows. Transfer Rib sts. to MB. Bind off or remove on W.Y.

WAISTBANDS: Make 2. Ten. 4/4 II

FNR: Cast on 132 (142) [152] sts. Knit 10 rows. Transfer Rib. sts. to MB. Bind off or remove on W.Y.

SLEEVE BANDS: Make 2, Ten. 4/4 II

FNR: Cast on 54 (60) [66] sts. Knit 10 rows. Transfer Rib sts. to MB. Bind off or remove on W.Y.

SLEEVE BAND

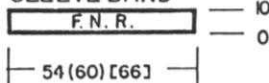

SKIRT:

FNR: Cast on 182 (190) [198] sts. Ten. 4/4 II. Knit 10 rows. Transfer Rib sts. to MB. Set Counter at 0. Begin following Chart for Skirt in Stockinette st. with Ten. 4.2. Knit 10 rows. Carriage on the right. ON THE LEFT side, bring to HP 32 (40) [48] sts. Knit 2 rows. (ALWAYS WRAP INSIDE NEEDLE TO PREVENT HOLE WHEN KNITTING SHORT ROWS).

CHART FOR SKIRT

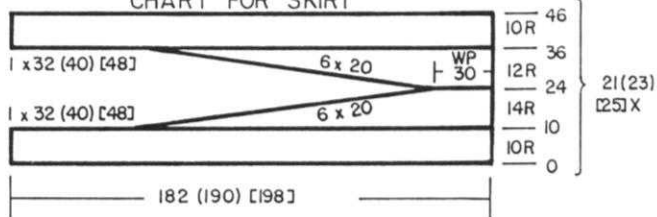

Bring to HP 20 sts. 6x on every 2nd row.

After R 24, on the RIGHT, push back to WP 20 sts. 6x then push back to WP 32 (40) [48] sts. 1x. Knit 2 rows.

One Pattern is completed after R 46.

REPEAT PATTERN CHART 21 (23) [25]x. Remove onto W.Y.

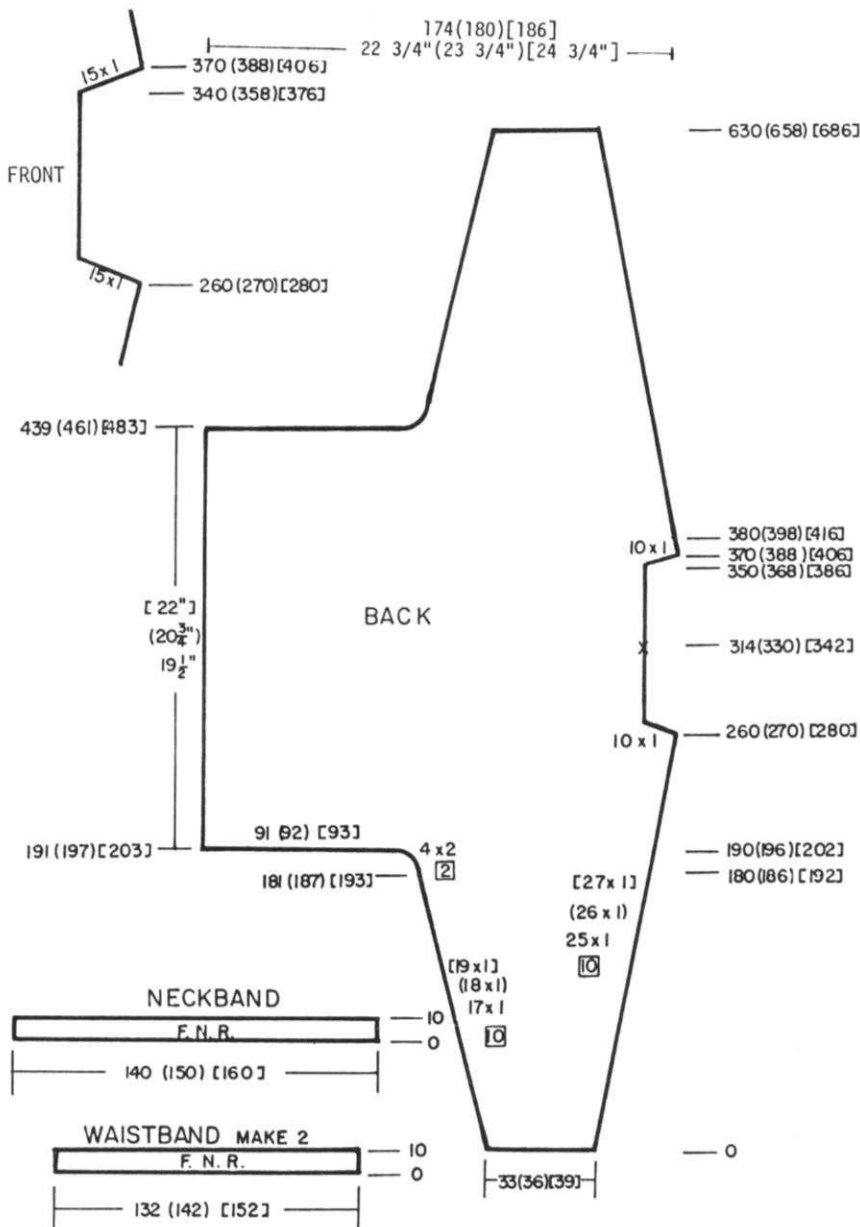
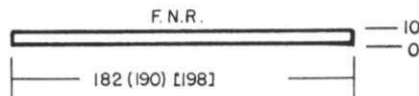

WAISTBAND: Make 2 - Ten 4.2

Bring to WP 120 (132) [144] Ndl's. With wrong side facing, hang 1/2 of skirt top edge onto these Ndl's. Knit 36 rows St. st. Hang first row of band onto machine to form hem. Bind off loosely.

LACE PETTICOAT: Tension 5- Col. 2

With W.Y. cast on 184 (192) [200] sts. Knit approx. 2" ending with 1 row Ravel Cord. Change to garment yarn and from LEFT to RIGHT, crochet cast on over these sts. behind the latches. You can use latch tool. Counter at 0. Knit 2 rows St. st. then begin Lace Pattern. Knit to Row 174 (178) [182]. Remove onto W.Y. Bring 136 (144) [152] Ndl's. to WP. Hang open sts. of Lace onto these Ndl's. decreasing evenly across St. st. Knit 2 rows. Work Short Rows: ON OPPOSITE SIDE OF CARRIAGE, bring into HP 10 sts. 4x ON EACH SIDE. Bring all Ndl's. to WP before knitting next 2 rows and continue in St. st. to Row 94 (98) [102]. Remove on W.Y.

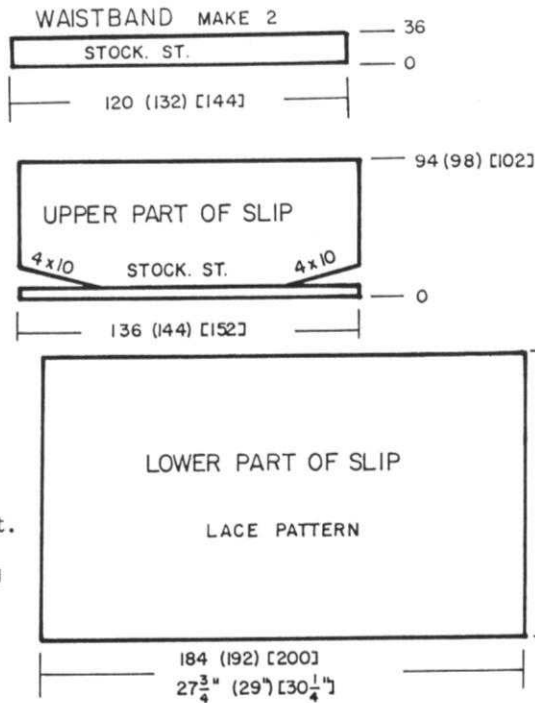

WAISTBAND: Make 2 Ten. 4

Bring to WP 122 (130) [138] Ndl's. Hang open sts. of Skirt edge onto these Ndl's. decreasing evenly across. Knit 12 rows St. st. Hang the first row of band onto the Ndl's. to form hem. Bind off loosely.

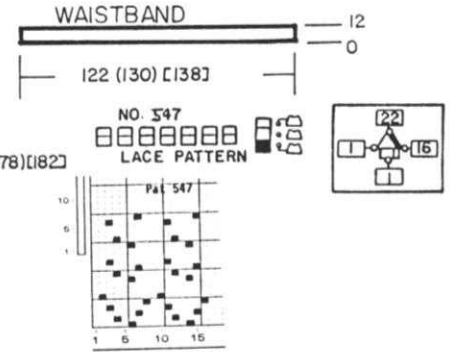

FINISHING: See General Instructions. Work 2 rows slip st. crochet around lower edge of skirt. Sew Buttons for trim on Skirt and Sequins to top. (See Picture).

548



WOMENS FEATHER & FAN TOP & SKIRT

SIZES: 8/10 (12/14)
 YARN: Venetia
 AMOUNT: 1 lb. 9 oz. 1 lb. 12 oz.
 TENSION: 5.1 Top, 5 for Skirt
 GAUGE: Top 16 sts. 23 Rows = 2"
 Skirt 15 sts. 21 Rows = 2"

Make on any Electronic or Standard Punch Card Machine with Lace Carriage.

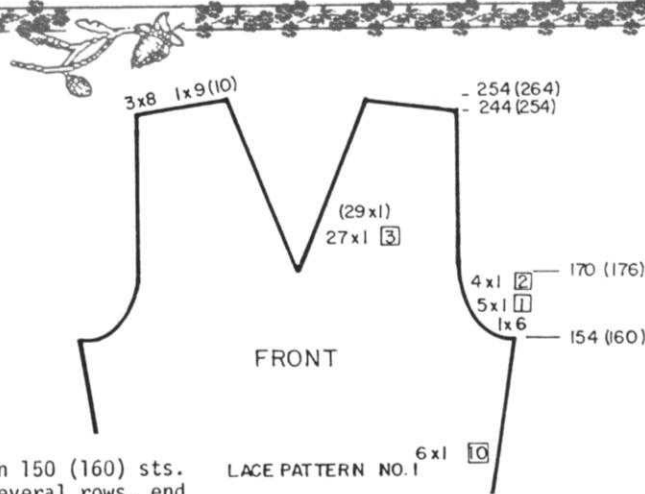

BACK:

With W.Y. cast on 150 (160) sts. After knitting several rows, end with 1 row Ravel Cord to the right. Change to garment yarn, Counter 0. Knit 2 rows. Set Program and begin Lace Pattern 1. After R 30 ON EACH SIDE, dec. 1 st. every 10 rows 6x. NOTE: While working in the Lace Pattern you must watch for the end stitches. PUSH THEM BACK MANUALLY TO B POSITION in order to avoid dropping sts. BEGIN INCREASES: ON EACH SIDE, inc. 1 st. every 10 rows 6x.

After R 154 (160) SHAPE ARMHOLE: ON EACH SIDE, dec. 1 st. EVERY ROW 9 (10)x, 1 st. EOR 4 (5)x, 1 st. every 4th row 2x. After R 244 (254), SHAPE NECK: Bind off the center 20 (24) sts. With a Ravel Cord, knit the sts. on the left back to NWP (A) position and complete the right side first. *ON NECK EDGE, bind off 6 sts. 2x, 5 sts. 1x, BUT AT THE SAME TIME, SHAPE SHOULDER: Bind off 8 sts. 3x, 9 (10) sts. 1x. Bring the sts. on the left to WP, Row Counter back to 244 (254) and complete left half. Follow instructions from *.

FRONT:

Knit same as back to R 154 (160). SHAPE ARMHOLE: ON EACH SIDE, bind off 6 sts. 1x, dec. 1 st. EVERY ROW 5x, 1 st. EOR 4x. After R 170 (176), divide in center for V neck shaping. Place sts. on left in NWP same as you did for back) and complete the right side first. *ON NECK SIDE, dec. 1 st. every 3rd row 27 (29)x. After R 244 (254), SHAPE SHOULDER: Bind off 8 sts. 3x, 9 sts. 1x. Bring Ndl's. on left back to WP Counter 170 (176) and complete left half. Follow instructions from *.

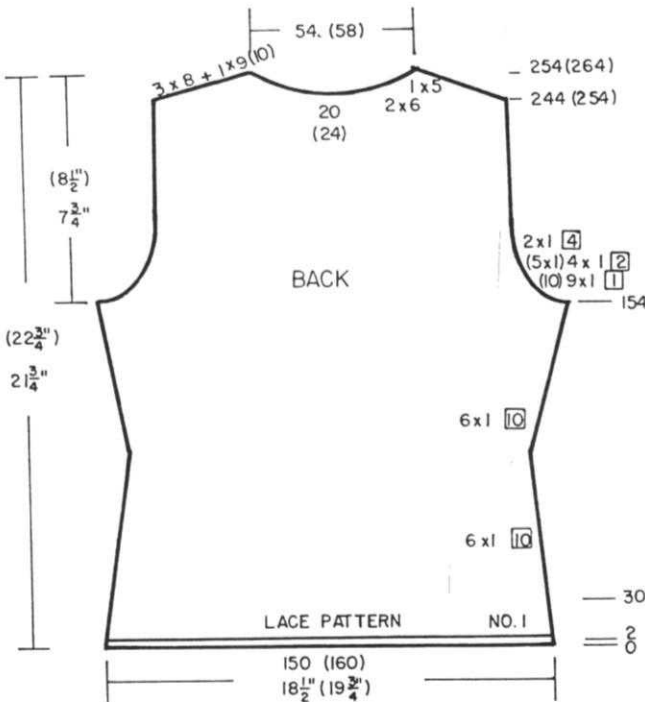

CONTINUED

SLEEVES: Gauge 14 STs 22 R=2"

With W.Y. cast on 100 (108) sts. the same as for front/back. After Ravel Cord row, change to garment yarn. Counter 0. Knit 2 rows, then begin Pattern 2. ON EACH SIDE, inc. 1 st. every 20 rows 7x.

After R 150 (154) SHAPE CAP: SEE CHART FOR DECREASES IN YOUR SIZE.

NOTE: also that right side differs from left.

After R 220 (228), bind off remaining sts.

CUFF: Make 2.

With W.Y. cast on 56 (62) sts. the same as for front/back. After Ravel Cord row, change to garment yarn. Counter 0. Knit 2 rows, then begin Pattern 1. After R 20, with wrong side facing, hang the open sts. of sleeve onto these Ndl. decreasing evenly across. Knit 1 row then bind off.

SKIRT: Knitted Sideways.

With W.Y. cast on 185 (192) sts. Knit several rows ending with 1 Row Ravel Cord to the right. Change to garment yarn. Counter 0. Knit 6 rows. Carriage on right.

*WORK SHORT ROWS:

ON OPPOSITE SIDE OF CARR. Bring to HP 10 (17) sts. Knit 2 rows (remember to always wrap inside Ndl. to prevent a hole when working Short Rows).

ON EVERY 2nd ROW, bring to HP, 20 sts. 5x, 30 sts. 2x. 15 sts. 1x. Bring all Ndl. to working position and knit 14 rows.

REPEAT FROM * 25 (26)x MORE

AND END WITH 7 rows Stockinette st. over all Ndl.

Remove onto W.Y.

Steam the edges of waste knitting carefully, then weave the open sts. together.

WAIST BAND: Make 2. T3

Cast on 120 (128) sts. (Use Cast on Comb if you have one) or W.Y.

With garment yarn, knit 32 rows St. st. Hang hem. With wrong side facing, hang HALF OF SKIRT WAIST onto these needle decreasing evenly across. Bind off LOOSELY. Repeat for 2nd half of skirt.

FINISHING:

See General Instructions.

Crochet around Neck opening and bottom edge of Top.

Crochet around Skirt bottom edge and lower edge of Top.

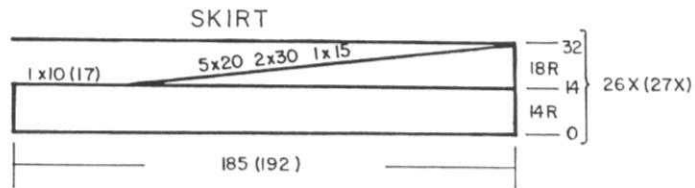
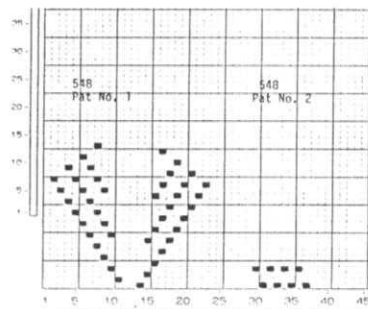
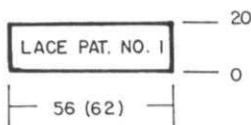
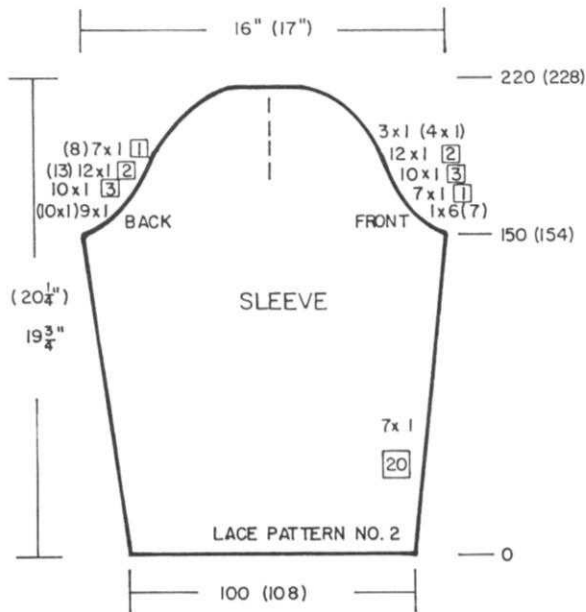

WAISTBAND MAKE 2

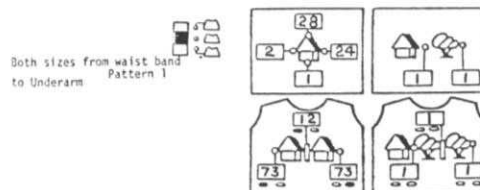
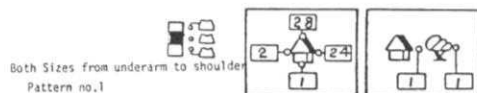
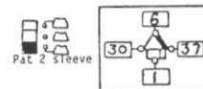
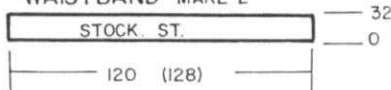

CROCHET TRIM

Work the crochet trim around lower edge of Skirt, Sleeves and Neckline.

R 1 - Single Crochet

R 2 - Ch 3, *Y0, insert hook into same st. REPEAT FROM * 4x MORE.

Skip 1 st., Y0, insert hook into next st. Y0 pull thru 2 loops on hook, Y0 pull thru remaining loops.

**Ch 3, Y0, insert hook into space made by skipped st. Y0 insert hook in same space, Y0 insert hook in same space, 4x MORE, Y0, skip next st. insert hook into next st. Y0 pull thru 2 loops on hook, Y0, pull thru remaining loops. REPEAT FROM **.



WOMENS DRESS

SIZES: 6/8 (10/12) [14/16]
 YARN: Marisa - 100% Cotton
 AMOUNT: 2 lbs. for all sizes.
 TENSION: KH 910 - T 4.2. KG 88 - T 6.
 Seed St. T 1.1
 K1, P1 Rib. T 1.1
 GAUGE: 16 sts. 22 rows = 2" (5 cm)

Made on the KH 910 with Garter Carriage KG 88. You can use your REGULAR CARRIAGE for ALL STOCKINETTE STITCH. Waistband K1, P1 Ribbing. Lower edge, neck and sleeve bands are all Seed Stitch using KG 88.

IMPORTANT: There are two sets of numbers shown on the Charts. The INSIDE NUMBERS are for setting the GARTER CARRIAGE and the OUTSIDE NUMBERS for the number of rows SHOWN ON THE MACHINE ROW COUNTER.

SKIRT BACK:

'e' cast on 168 (178) [184] sts. Knit 2 rows Stockinette stitch with Tension 3. With KG 88 Garter Carriage and Ten. 1.1, work 16 rows SEED ST. With REGULAR CARRIAGE, continue in Stockinette st - Ten. 4.2. After Row 270 (280) [290] remove onto W.Y.

SKIRT FRONT:

Work the FRONT the same as the back, completing the 16 rows SEED ST. (Row 18). Begin PATTERN. WORK 42 ROWS PATTERN 1. Ten. 6
 108 ROWS PATTERN 2.
 96 ROWS PATTERN 3.
 After R 264 - continue in St. st. to Row 270 (280) [290]. Remove the sts. onto W.Y.

BELT:

'e' cast on 5 sts. Set machine for knitting a cord - Ten. 5. Knit a cord approximately 60" long then bind off. Make TASSEL by winding yarn around 6" cardboard then cut 1 end and tie at other end. (See Picture). Make a 2nd cord and tie tassel at each end of cord.

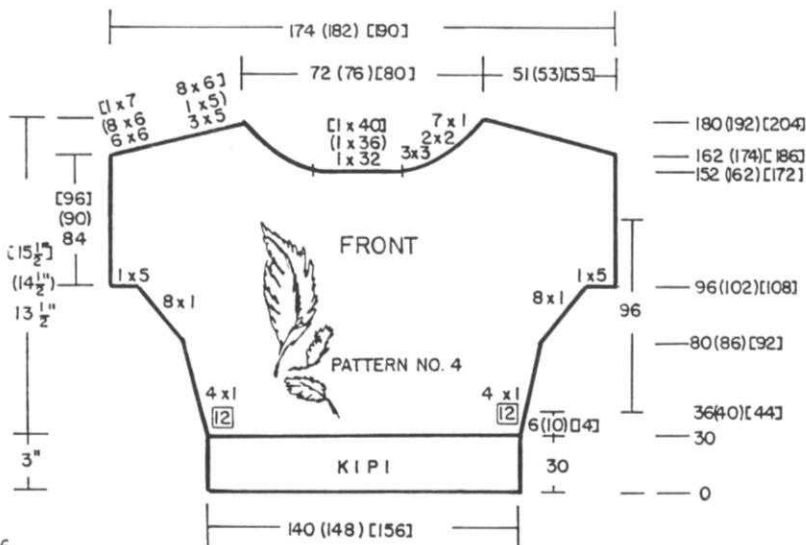

FRONT BODICE:

Bring 140 (148) [156] Ndl. into B (working) position. Hang the FRONT SKIRT onto these Ndl. DOUBLING every 5th & 6th st. on one Ndl. Knit 1 row LEFT TO RIGHT in Stockinette st. THEN SET G CARRIAGE COUNTER for 30 rows K1, P1 Ribbing Tension 1.1. Change to Ten. 6 and work 6 (10) [14] rows Stockinette st. AT THE SAME TIME, WORK THE INCREASES ON EACH SIDE AS SHOWN ON THE CHART. After Row 36 (40 [44]), BEGIN PATTERN 4 for 96 rows.

When Pattern is completed, change to Regular Carriage and Ten. 4.2 and continue in Stockinette st. After R 152 (162) [172], SHAPE NECK: USE SHORT ROWS FOR SHAPING NECK AND SHOULDERS.

Put the center 32 (36) [40] sts. and all sts. on the left of these into holding position and complete the right side first.

*ON NECK SIDE, SHORT ROW 3 sts. 3x, 2 sts. 2x, 1 st. 7x AND AT THE SAME TIME after R 161 (173) [185] SHORT ROW SHOULDER by holding the sts. for YOUR SIZE as shown on the Chart. After R 180 (192) [204], knit 1 row OVER THE SHOULDER STS. ONLY then remove them onto W.Y. LEAVE THE CENTER NECK PLUS ALL STS. ON THE RIGHT IN HP. Attach yarn on the right of remaining sts. Knit 1 row to the left then turn the Row Counter back to 152 (172) [182] and complete the left half following the instructions from *

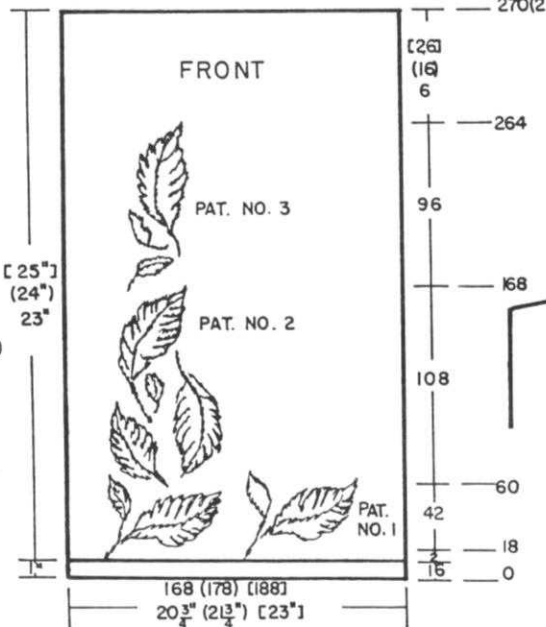

BACK BODICE:

Work the back the same as the front OMITTING THE DESIGN. After R 162 (174) [186], SHAPE SHOULDER ON EACH SIDE using SHORT ROWS same as you did for the front BUT AT THE SAME TIME, after R 168 (180) [192], work the NECK SHAPING USING SHORT ROWS as you did for the front by following the Chart shaping for your size.

BACK NECKBAND:

Bring 72 (76) [80] Ndl. to WP. Pick up the open sts. held on waste yarn across the neck with wrong side facing you. Remove the waste yarn. Work SEED STITCH changing the tensions every 2 rows as follows and AT THE SAME TIME, ON EACH SIDE, decrease 1 st. every 2nd row 5x. Work 2 rows each - Ten. 3.1, 3, 2.2, 2.1, then 4 rows Ten. 2. After Row 12, use the GARTER CARRIAGE with Tension 10 and bind off.

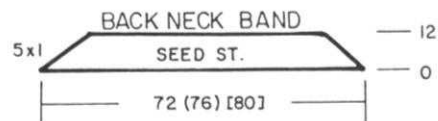

CONTINUED

SLEEVE BANDS: Make 2

CLOSE SHOULDERS FIRST.

Bring 92 (100) [108] Ndl.s. to WP. Pick up the edge of sleeve and hang onto these Ndl.s. Knit 1 row STOCKINETTE STITCH FROM LEFT TO RIGHT, then set Garter Carriage and work the Seed St. for 12 rows. Bind off with Garter Carriage with Tension 10.

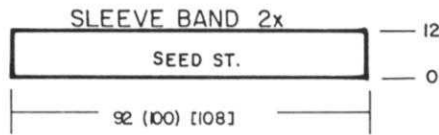

FRONT NECKBAND:

Bring 82 (86) [90] Ndl.s. to WP. Hang the open sts. of front neck onto these Ndl.s. increasing 5 sts. ON EACH SIDE along the neck shaping. Remove the waste knitting then complete same as for back neckband. Dec. on each side 1 St EOR 5x. FINISHING: See General Instructions.

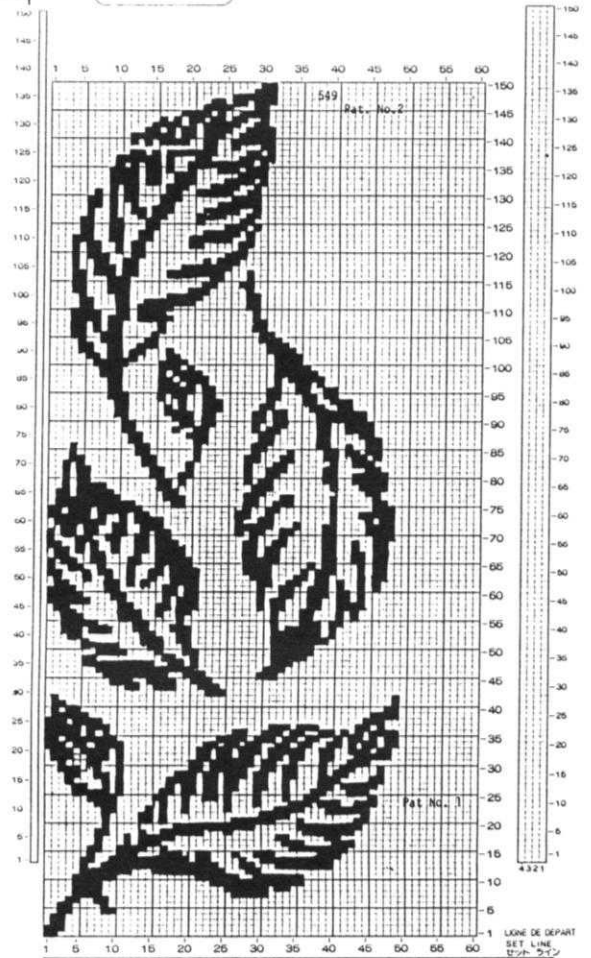
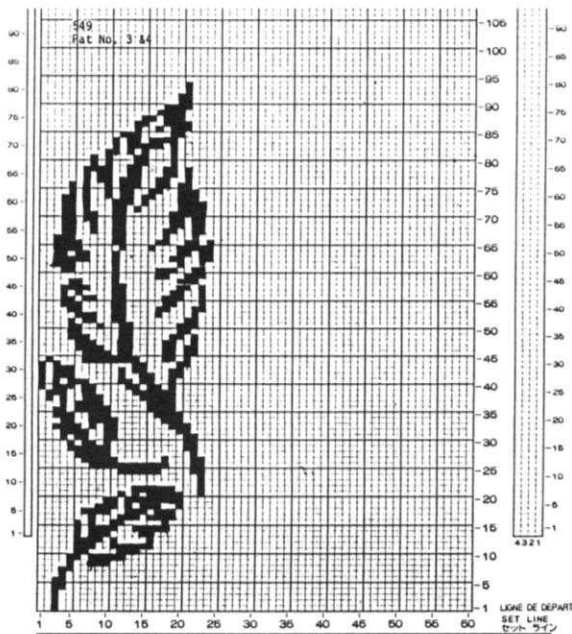
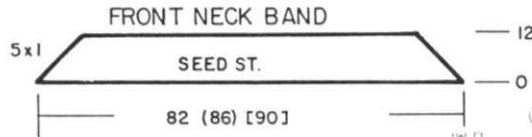

NO 549
SKIRT PAT. NO. 1

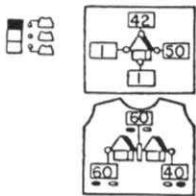

NO 549
SKIRT PAT. NO. 2

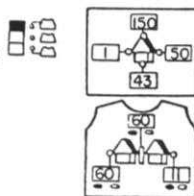

NO. 549
SKIRT PAT. NO. 3

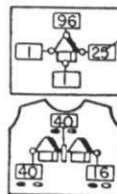

NO. 549
SKIRT PAT. NO. 4

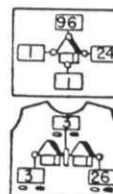



WOMENS TUNIC

SIZES: 8/10 (14/16)

YARN: Venetia

AMOUNT:

Col. 1 1 lb. 4 oz.

Col. 2 1 lb. 4 oz.

TENSION: Fair Isle 5, Rib. 2/2 II

GAUGE: 18 sts. 21 Rows = 2" (5 cm)

Make on any Standard or Electronic machine with Ribber. Fair Isle Design. Punch Card or draw on Mylar Sheet.

BACK:

With W.Y. Cast on 180 (200) sts. After several rows, end with 1 row Ravel Cord to the right. Change to Color 1, knit 2 rows St. st., setting Pattern on 2nd row. Insert Color 2 in B Feeder and continue in Fair Isle Design. After R 202 (220), ON EACH SIDE bind off 23 (27) sts. After R 300 (330), SHAPE NECK. Bind off the center 40 (50) sts. Put the sts. on left into HP or NWP with Ravel Cord and complete the right side first. *ON NECK SIDE, dec. 1 st. EOR 5x. Bind off remaining sts. Bring Ndls. on left to WP and complete left half. Follow instructions from *.

LOWER BAND: for Back.

With Col. 2, cast on 154 (170) sts. Knit 32 rows St. st. Hang hem. With wrong side facing, hang the open sts. of back onto these Ndls. decreasing evenly across. Bind off. When front is completed, knit another band the same way.

FRONT:

KNIT the front the same as back to R 100 (110). Bind off the center 10 sts., put the Ndls. on left into HP (same as you did for back) and complete the right side first. *Knit to R 284 (310). ON NECK EDGE, bind off 7 (10) sts. then on every 2nd row, dec. 1 st. 13 (15)x. After R 310 (340), bind off the remaining sts. Bring the Ndls. on left to WP. Turn Row Counter back to 284 (310) and complete left half. Follow instructions from *. Make band for lower edge same as back band.

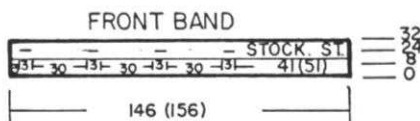

FRONT BANDS: Make 2, omitting buttonholes in 1 section. With W.Y. cast on 146 (156) sts. After several rows end 1 row Ravel Cord to the right. Change to Color 2. Knit 8 rows. Make BUTTONHOLES as shown on the Chart. Knit to R 24. REPEAT BUTTONHOLES over same Ndls. Knit to R 32. Hang hem by picking up first row of Col. 2. Knit 1 row then remove onto W.Y.

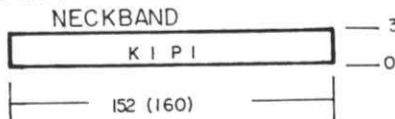

NECKBAND: K1 P1 Rib. With Col. 1, cast on 152 (160) sts. Knit to R 34. Transfer Rib. sts. to MB. Knit 1 row St. st. Remove onto W.Y.

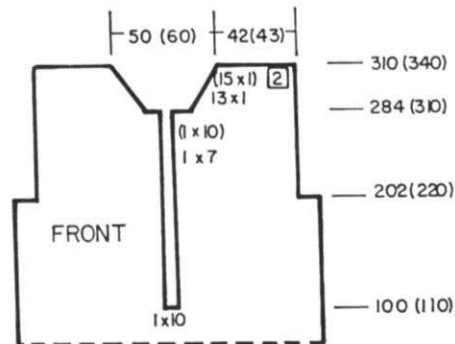
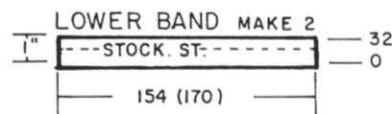
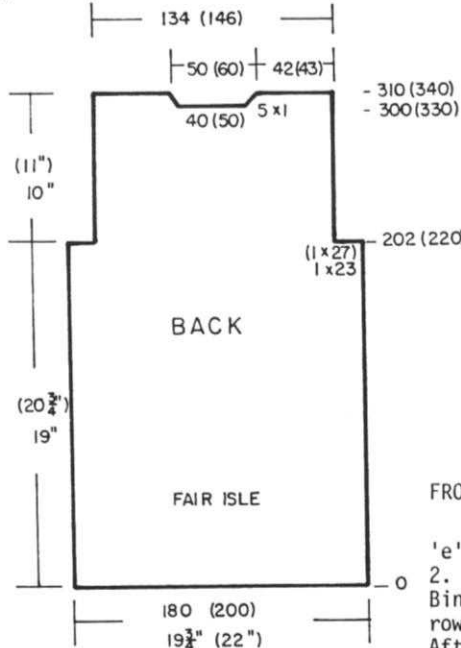

FINISHING:
See General Instructions.

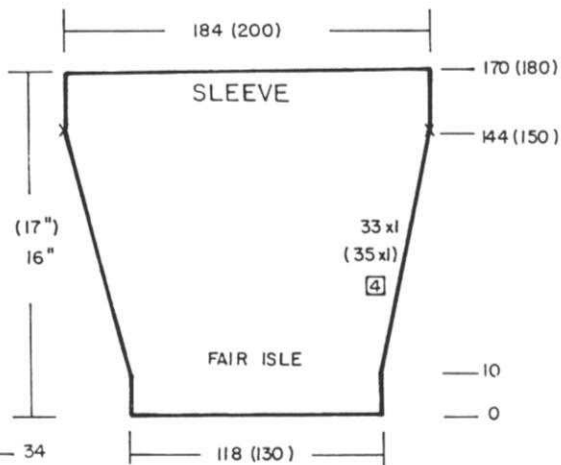

SLEEVES:

With Col. 1, 'e' cast on 118 (130) sts. Knit 2 rows setting Fair Isle Pattern on 2nd Row. Knit in Pattern to R 10. ON EACH SIDE, inc. 1 st. every 4th Row 33 (35)x. Mark R 144 (150) for setting sleeve into armhole. After R 170 (180) bind off.

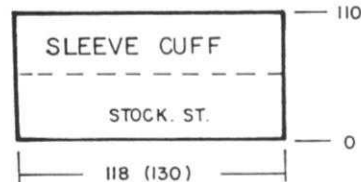

SLEEVE CUFFS:

With Col. 2, cast on 118 (130) sts. Knit 110 rows. Pick up the first row to form hem. With wrong side facing, hang Sleeve edge onto these Ndls. Bind off LOOSELY.

FRONT FACING (Optional) Make 1, reverse 1.

'e' cast on 62 (68) sts. with color 2. Knit St. st. to R 83 (89). Bind off 7 (10) sts. then every 2nd row, dec. 1 st. 13 (15)x. After R 110 (120) bind off remaining sts.

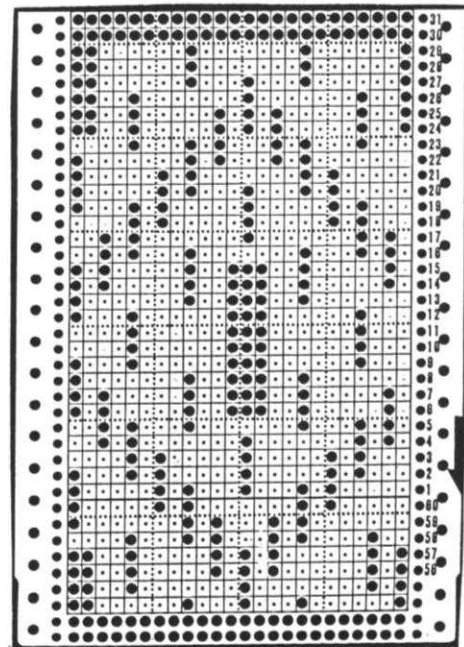
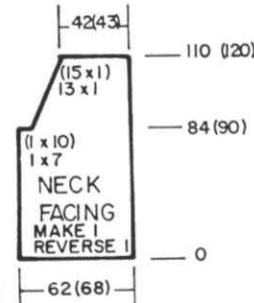

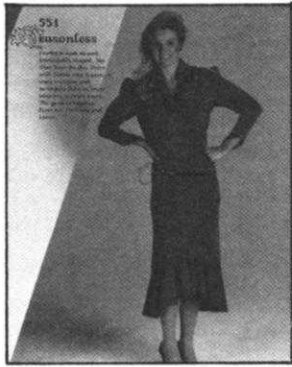

Womens Dress

SIZES: 10/12 (14/16)
 YARN: Venetia
 AMOUNT: 2 Lbs. all Sizes
 TENSION: 4
 GAUGE : 16 Sts. 26 R = 2" (5cm)

Can be made on any Standard Machine. All Stockinette St.

BACK:

'e' cast on 168 (180) sts. Knit in St. st. to R 196 (200).
 ON EACH SIDE, dec. 1 st. every 10 rows 9x. After R 296 (300), ON EACH SIDE, inc. 1 st. every 10th Row 9x.
 After R 402 (410) SHAPE ARMHOLE: ON EACH SIDE, bind off 8 (10) sts. then dec. 1 st. EOR 20x.
 After R 496 (510) SHAPE NECK: BO the center 66 (70) sts. put the Ndl. on left in holding position (or NWP) and complete the right side first.
 *ON NECK EDGE, Dec. 1 St. EOR 5x. AT THE SAME TIME, SHAPE SHOULDER. Bind off (or use Short Row method) 4 sts. 3x, 3 sts. 2x. (4 sts. 5x).
 Bring the Ndl. on left to WP, turn Row Counter back to 496 (510) and complete the left half. Follow Instructions from *.

FRONT:

To the right of 0 and beginning with Nd1. 73, 'e' cast on 12 (18) sts. (See Chart). Work St. st. Knit 2 rows. On the LEFT, inc. 1 st. EVERY ROW 72x. After R 74, put these sts. into HP (or NWP with Ravel Cord). Drop yarn.
 ON THE LEFT of 0, using another ball of yarn, 'e' cast on beginning with Nd1. 84 (90) 12 (18) sts. Knit 2 rows then on the RIGHT inc. 1 st. EVERY ROW 72x. After R 74, bring all Ndl. on right to WP and continue in St. st. over ALL NDLS.
 After R 296 (300) ON EACH SIDE, inc. 1 st. every 10th row 9x. After R 402 (410), divide in center. Put the sts. on the left into HP or remove on waste yarn. Complete right side first.
 *ON ARMHOLE SIDE, BO 8 (10) sts. then dec. 1 st. EVERY ROW 20x. AT THE SAME TIME, ON NECK EDGE, dec. 1 st. every 3rd row 19 (20)x, then 1 st. EOR 18 (20)x. After R 496 (510), SHAPE SHOULDER same as back.
 Bring Ndl. on left into working position, turn Counter back to 402 (410) and complete left half. Follow the instructions from *.

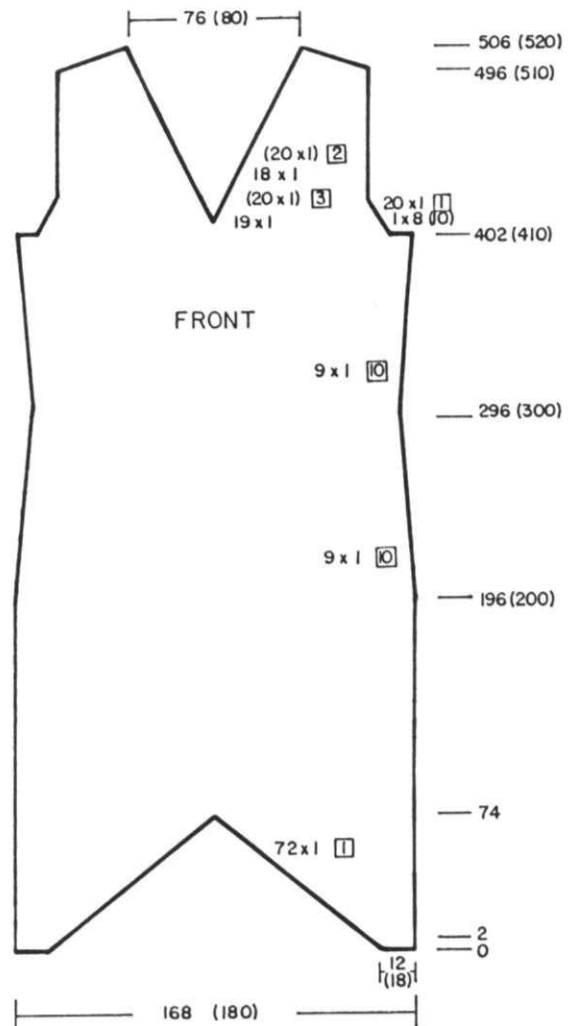
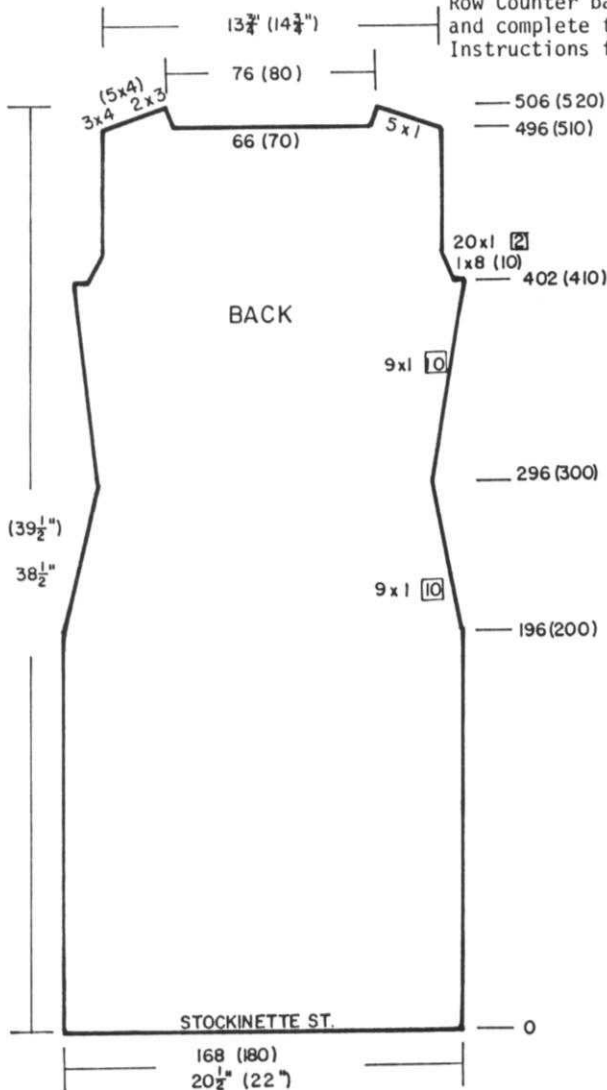

SLEEVES:

To the right of 0, beginning with Nd1. 24, 'e' cast on 7 (10) sts. (See Chart). ON THE LEFT, inc. 1 st. EOR 23x. After R 48, put these sts. into HP.

TO THE LEFT OF 0, 'e' cast on beginning with Nd1. 30 (33) 7 (10) sts. and work same as right side, increasing 1 st. EOR 23x on the Right.

After R 48, continue working over all 60 (66) sts. BUT AT THE SAME TIME, ON EACH SIDE, inc. 1 st. every 5th row 31 (32)x.

After R 220 (224) SHAPE CAP: ON EACH SIDE, BO 8 (10) sts. then dec. 1 st. every 3rd R 13 (20)x, 1 st. EOR 20x. After R 316 (326) bind off remaining sts.

SKIRT RUFFLE:

'e' cast on 64 (70) sts. Knit 4 rows. ON LEFT, begin Short Row decreases.*Bring into HP 6 sts. 8 (9)x (See Chart).

ALL NDLS. IN WORK, knit 6 rows. REPEAT FROM * 73 (79)x in ALL, ending with only 4 rows over all Ndls. Bind off.

COLLAR: Make 2 Different Pieces.

'e' cast on 190 (200) sts. Knit St. st. to R 180 (200). Hang hem. BO.

'e' cast on 25 sts. Knit to R 180 (200). Bind off. (after forming hem)

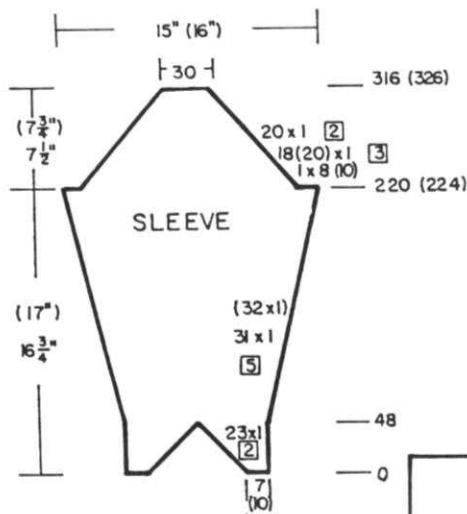

FINISHING:

Join side seams. Join both shoulders. Beginning at center of back, join Ruffle to lower edge of Dress. Seam underside of sleeves. Set in Sleeves, gathering top to form puff. Join ends of Collar to form a circle and attach to neck opening. Optional: We used snap fasteners for the collar so that it can be removed for additional styling possibilities. Single crochet around sleeve cuff and around neck if collar is detachable.

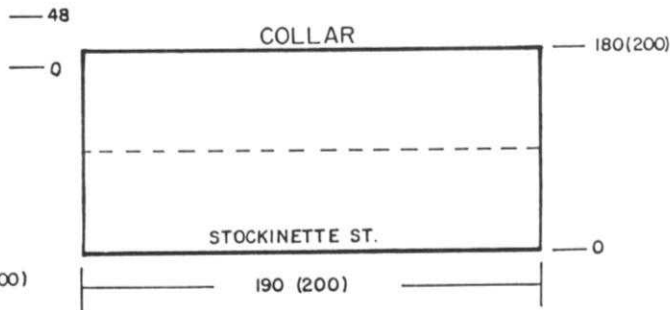
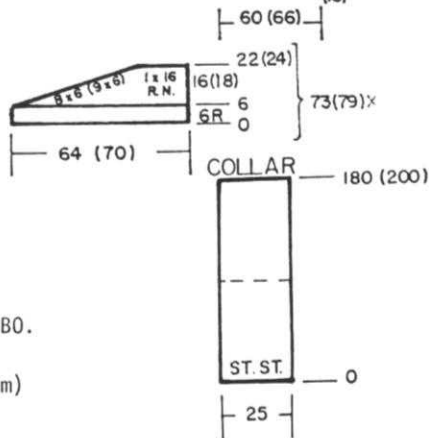

Let's start
MACHINE KNITTING

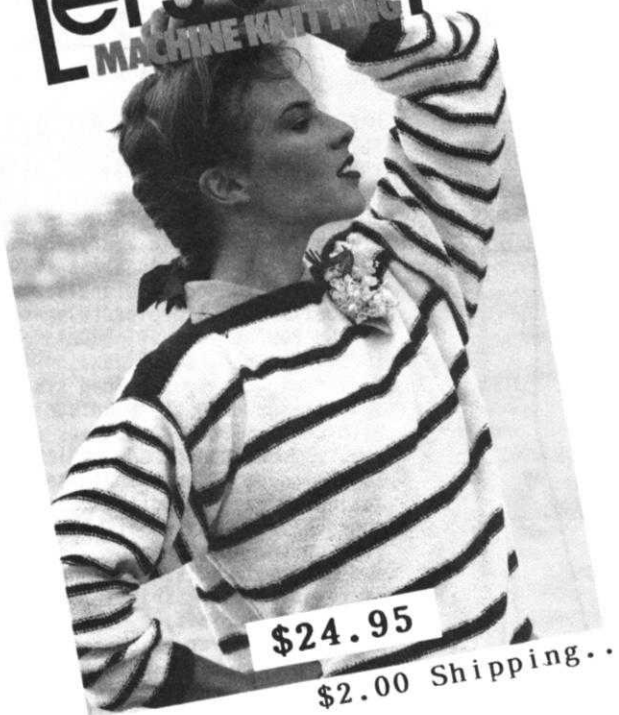

\$24.95

\$2.00 Shipping..

LETS START MACHINE KNITTING....

This is the book we have all been waiting for.. A step by step volume of instructions... profusely illustrated with hundreds of line drawings, caricatures of people mouthing instructions and humorous comments.. It's a large book 8-3/4 x 11-3/4" and 158 pages... packed full of good easy to understand information embracing practically everything one needs to know about knitting, blocking, finishing, etc... It's so complete it even tells you when to take a coffee break! Six full size Knitleader sheets are included with instructions for twelve garments....All illustrated in full color...

It's the best practical machine knitting instruction book yet and it's excellent for all Japanese made knitting machines.

Order from your local dealer or direct from KNITKING at 1128 Crenshaw Blvd., Los Angeles, California 90019.



SLEEVE BANDS: Make 2

SEE FINISHING & Close shoulders first.

FNR: Cast on 125 (130) sts. Knit 10 rows. Transfer Rib sts. to MB, knit 1 row. With wrong side facing, pick up sts. along armhole and hang onto these Ndl. Bind off.



BELT:

With garment yarn, 'e' cast on 34 sts. Knit approximately 444 (450) rows St. st. (or to your size). Remove on W.Y.

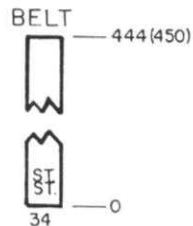

WOMENS DRESS

SIZES: 6/8 (10/12)
 YARN: Venetia
 AMOUNT: 1 lb. 6 oz. 1 lb. 8 oz.
 TENSION: St. st. 4.1 Rib. 5/5 II
 GAUGE: 16 sts. 23 rows = 2" (5 cm)
 1 Belt Buckle and small amount fine elastic.

Make on any standard Machine with Ribber.

BACK:

Cast on 160 (170) sts. Knit 10 rows. Transfer Rib sts. to MB. Knit 2 rows T 4.1 over all sts. Work Short Rows. On OPPOSITE SIDE OF CARR. bring to HP, 10 sts. 4x ON EACH SIDE. After R 20 continue in St. st. to R 288 (294). ON EACH SIDE, increase 1 st. every 8th row 3x, then 1 st. every 5th row 11 (12)x. After R 368 (378) mark each side with W.Y for setting in sleeves. After R 468 (482), work Short Rows. for shoulder. ON OPPOSITE SIDE OF CARR. Bring to HP 7 sts. 10x ON EACH SIDE. After R 488 (502), bring Ndl. opposite Carr. into working position before knitting the next 2 rows. Mark for neck. Bind off shoulder and neck sts. separately.

FRONT SKIRT SECTION:

Cast on same as Back and knit to R 288 (294). Remove on W.Y.

FRONT BODICE: Make 1, reverse 1

With W.Y. cast on 159 (165) sts. Knit several rows ending 1 row Ravel Cord to the right. Change to garment yarn. Counter 0. Counting from the right (left for second half), mark st. 21 (24) then mark every 12th st. 5x MORE. (Use W.Y. for markings for pleats). Knit 10 rows. ON THE LEFT, dec. 1 st. every 3rd row 67 (70)x AT THE SAME TIME, on the RIGHT, inc. 1 st. every 8th row 3x, 1 st. every 5th row 11 (12)x. After R 189 (197), work Short Rows same as back for shoulder (see Chart). After R 209 (217) bring all Ndl. to WP and knit 2 rows. Counting from the RIGHT (left) mark sts. 33 (39) then every 12th st. 5x more same as before.

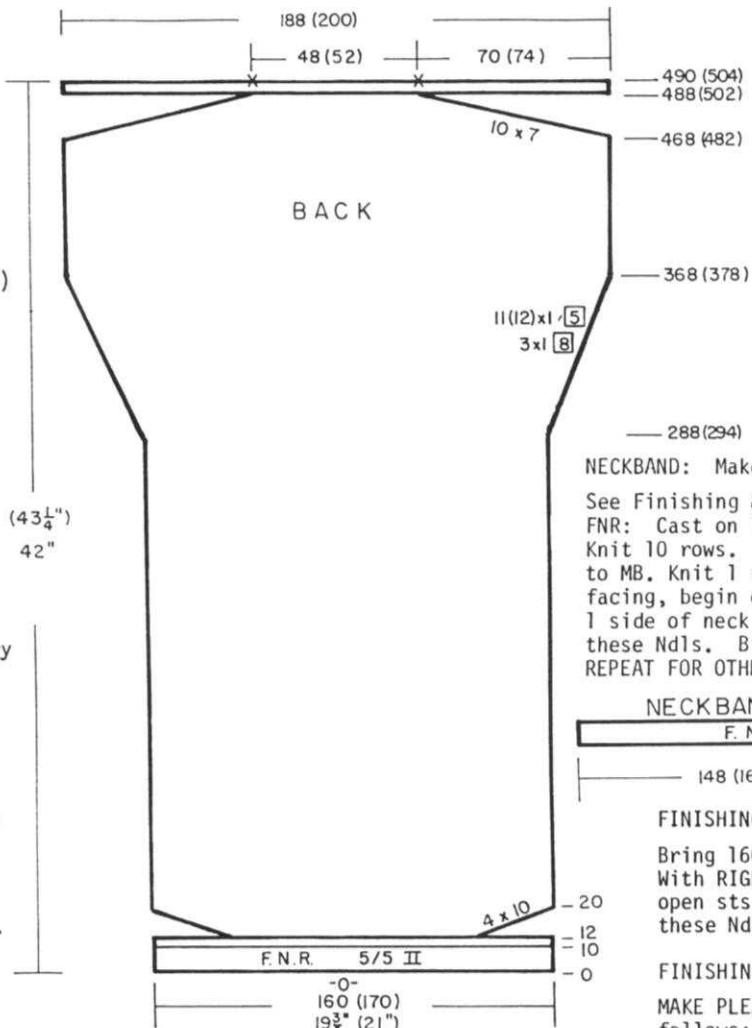

NECKBAND: Make 2.

See Finishing & close Shoulders first. FNR: Cast on 148 (160) sts. Knit 10 rows. Transfer Rib sts. to MB. Knit 1 row. With wrong side facing, begin center back and pick up 1 side of neck edge and hang onto these Ndl. Bind off. REPEAT FOR OTHER BAND

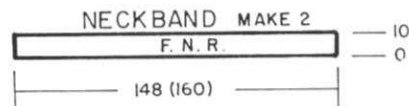

FINISHING:

Bring 160 (170) Ndl. to WP. With RIGHT SIDE FACING, hang the open sts. of SKIRT FRONT onto these Ndl. With WRONG side facing,

FINISHING:

MAKE PLEATS IN BODICE FIRST as follows: ON THE RIGHT SIDE, at WAIST EDGE. Make 3 pleats using the marked sts. as a guide. Fold toward the OUTSIDE. ON THE WRONG SIDE, sew pleats down approx 2 1/2". Make pleats at shoulder in the same way, folding to the outside and sew down on the inside (See picture). ATTACH BODICE TO SKIRT FRONT: Bring 160 (170) Ndl. to WP. With RIGHT side facing, hang the open sts. of Skirt front onto these Ndl. WITH WRONG SIDE FACING, pick up open sts. of RIGHT BODICE and beginning at LEFT edge, hang onto these Ndl. making sure you hang the pleats correctly. Beginning at LEFT EDGE, pick up the open sts. of LEFT Bodice and hang onto Ndl. overlapping part of right bodice. Knit 1 row over all sts. Bind off. Work a casing for elastic on the inside at waist. Ch 5, skip 5 sts. slip st. into next st. and repeat making the chains in a zig zag. Thread elastic through.

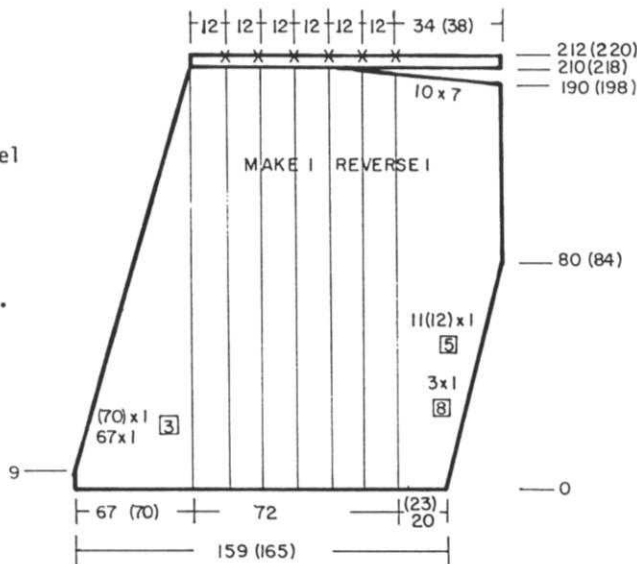



WOMENS CARDIGAN

SIZES: Medium Large
YARN: Cordella = Col. 1
 Alpaca = Col. 2, 3, 4
AMOUNT:
 COL. 1 4 Balls both Sizes
 COL. 2 6 Balls 6 Balls
 COL. 3 6 Balls 6 Balls
 COL. 4 3 Balls 3 Balls
TENSION: See Instructions.
GAUGE: 14 Sts. 24 R. = 2"

Make on any Standard Machine with Ribber. Use KRC COLOR CHANGER for easier knitting.

PATTERN:

You must change tensions when knitting English Rib and K1 Ribbing. The Pattern is worked in the following Color sequence throughout.

- 16 Rows English Rib.- Col. 2 - T 8/6 I
- 4 Rows K1, P1 Rib. - Col. 1 - T 2/2
- 16 Rows English Rib.- Col. 3
- 4 Rows K1, P1 Rib. - Col. 1
- 16 Rows English Rib.- Col. 2
- 4 Rows K1, P1 Rib. - Col. 1
- 16 Rows English Rib.- Col. 4
- 4 Rows K1, P1 Rib. - Col. 1
- 16 Rows English Rib.- Col. 4
- 4 Rows K1, P1 Rib. - Col. 1

BACK: Ribbing Pattern.

Set Color Changer. Thread Colors 2, 3, 4, into Color Changer. Leave Button 1 for Color 1.

With Col. 1, Tension 3/3 II, cast on 157 (167) sts. After 4 rows circular, change tension 3/3 I and knit K1, P1 Rib. After R 12, change Ribber setting for English Rib and continue following Pattern sequence as listed. After R 200 (210), SHAPE ARMHOLE: ON EACH SIDE, BO 21 (22) sts. Continue in Pattern. After R 312 (332) SHAPE SHOULDER: ON EACH SIDE, bind off (or use short row method) 7 (7) sts. 4x, 6 (8) sts. 1x. Transfer Rib sts. to MB and bind off or remove onto W.Y.

FRONT: Make 1, reverse 1.

With Col. 1, cast on same as Back 81 (87) sts. Knit same as back to R 200 (210). ON NECK EDGE, every 4th dec. 1 st. 26 (29)x AND AT THE SAME TIME SHAPE ARMHOLE same as back. After R 312 (332) SHAPE SHOULDER same as back. Knit 2nd half of front with reverse shapings.

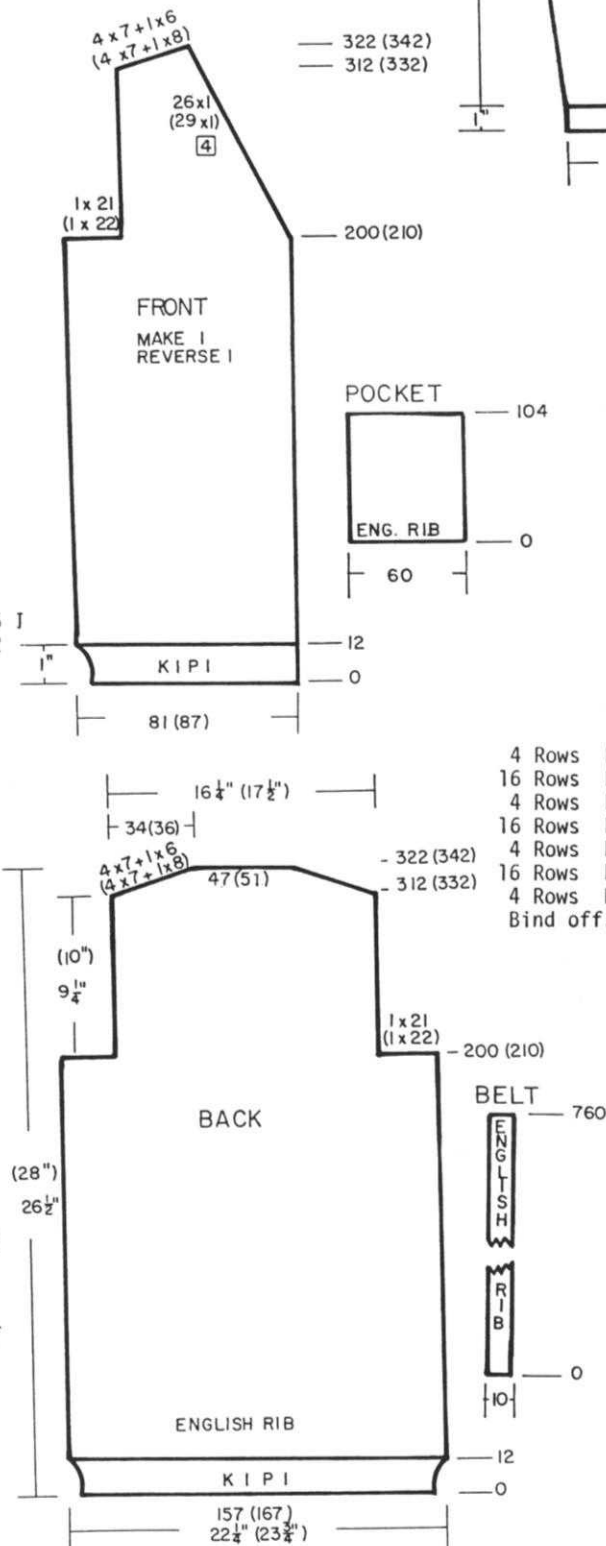

PATTERN CHART

C-1	4
C-4	16
C-1	4
C-4	16
C-1	4
C-2	16
C-1	4
C-3	16
K1 P1 C-1	4
C-2	16
ENGLISH RIB	16

SLEEVES:

With Col. 1 cast on same as Front and Back 65 (75) sts. After R 12, continue in stripe Pattern and ON EACH SIDE, inc. 1 st. every 4th row 44 (45)x. After R 202 (216), mark each side with W.Y. for setting sleeve into armhole. After R 236 (252), transfer Rib sts. to MB and bind off or remove onto W.Y.

POCKET:

K1, P1 Rib: Cast on 60 sts.. Make 2 rows selvedge ending with Carr. on the left. Change to Col. 2. Knit 16 rows English Rib. Change to Col. 1, knit 4 rows K1, P1. Change to Col. 4, knit 16 rows English Rib. 4 Rows K1, P1 Rib - Col. 1. 16 Rows English Rib - Col. 4. 4 Rows K1, P1 Rib - Col. 1. 16 Rows English Rib - Col. 2. 4 Rows K1, P1 Rib - Col. 1. 16 Rows English Rib Col. 3. 4 Rows K1, P1 Rib Col. 1. Bind off.

FRONT & NECK BAND

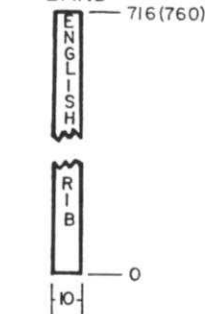

FRONT BANDS: - Color 1
 ENGLISH RIB: Cast on 10 sts. Knit to R 716 (760) (approximately). Transfer Rib sts. to MB and remove onto W.Y. If Band is too long, unravel end to desired length. If too short, rehang on machine and make additional rows.

BELT: - Color 1
 ENGLISH RIB: Cast on 10 sts. and knit to R 760, Transfer Rib sts. to MB and BO.

FINISHING:

See General Instructions.



WOMENS 2 PIECE SUIT

SIZES: 10/12 (14/16)
 YARN: Venetia
 AMOUNT: 2 1/2 lbs. for all sizes.
 TENSION: St. st. 4.2
 Rib Tensions - See Instructions.
 GAUGE: 17 sts. 24 Rows = 2" (5 cm)
 NOTIONS: Elastic for Skirt Band & Jacket Waist. Snap fasteners, Hook & Eye, Shoulder Pads, 7" Zipper for Jacket Front.

Make on any standard machine with Ribber. Stockinette stitch and FNR for casings and Bows.

JACKET BACK:

With W.Y. cast on 172 (182) sts. After several rows, knit 1 row Ravel Cord to the right. Counter 0. Change to garment yarn. Work St. st. ON EACH SIDE, inc. 1 st. every 10th row 6 (7)x. After R 100 (106), ON EACH SIDE, bind off 9 (10) sts. then EOR dec. 1 st. 12 (13)x, 1 st. every 4th row 2x. After R 196 (206), SHAPE SHOULDERS: ON EACH SIDE, bind off (or use Short Rows) 8 sts. 4x, 11 sts. 1x (9 sts. 5x). After R 206 (216), bind off (or remove on W.Y.) the remaining sts.

PEPLUM FOR BACK:

Bring 122 (132) Ndl. to WP. With wrong side facing, hang open sts. of lower back onto these Ndl. decreasing evenly across. Push Ribber up to WP. Pitch to H. *Bring to WP required Ndl. on Ribber for FNR. Knit 1 row (tight tension) right to left. Hang RIBBER Cast on Comb. Hang weights. Set Carriages for knitting the following. (See Practical Knitting Hints this issue). Knit 4 rows MAIN BED ONLY - T 4. Push in Both Part Buttons on MB. Knit 4 rows RIBBER BED ONLY T 3.1 Release Part Buttons on MB. Change Rib setting back to P. Transfer Rib sts. to MB. (This is casing for elastic for the band). ON MAIN BED, continue in St. st, ON EACH SIDE, inc. 1 st. every 11th row 5 (6)x. Knit 9 rows straight, then ON EACH SIDE

DECREASE 1 st. every 11th row 5 (6)x. After R 130 (138), pick up sts. from first row of St. st. to form hem. Bind off*.

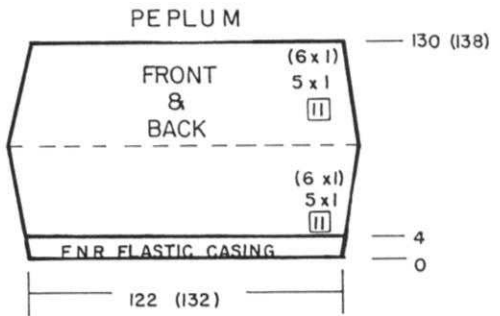

PEPLUM FOR FRONT:

Bring to WP 122 (132) Ndl. With wrong side facing, hang the open sts. of the bottom edge of BOTH FRONT SECTIONS onto these Ndl. NOTE: Begin from the center and hang the edge trim just finished onto center Ndl. so they DO NOT overlap, then work towards the outside edges and make decreases evenly across. Bring Ribber to WP, Pitch to H and complete same as BACK PEPLUM from * to *. See Chart.

MAKE FRONT EDGE TRIM FOR JACKET NEXT. Make 2.

Bring to WP 84 (88) Ndl. With WRONG SIDE FACING, take 1 front section and hang the front edge onto these Ndl. With T 4.2, knit 16 rows. Pick up the first row of knitting and hang onto these Ndl. to form hem. Bind off. REPEAT FOR 2nd FRONT.

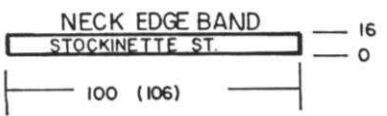
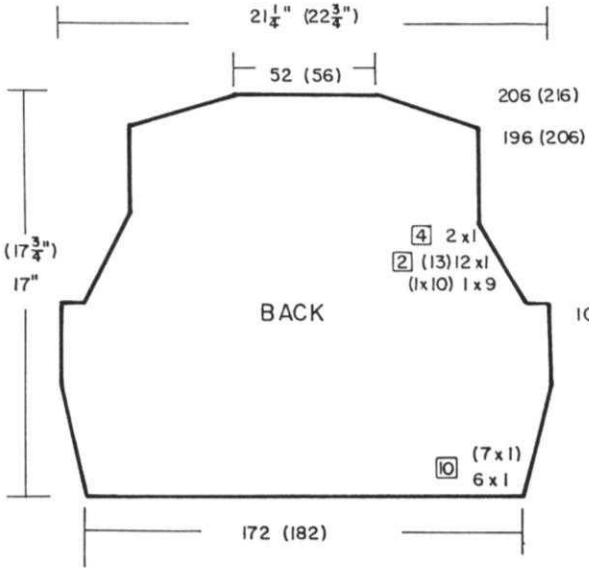
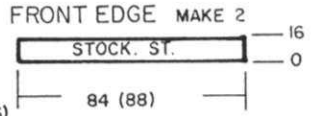

NECKBAND:

Bring 100 (106) Ndl. to WP. With wrong side facing, hang the neck edge onto these Ndl (Be sure to include front Neck Trim). Knit 16 rows St. st. Pick up first row of knitting to form hem. Bind off.

SLEEVES:

With W.Y. cast on 124 (132) sts. same as you did before. After Ravel Cord row, change to garment yarn. Counter 0. Knit St. st. to R 180 (184). SHAPE CAP: ON EACH SIDE, bind off 9 (10) sts. 1x then dec. 1 st. every 12th row 5x, 1 st. every 4th row 6 (7)x. After R 240 (246), ON EACH SIDE, dec. 1 st. EOR 7x. After R 280 (288) ON EACH SIDE, bind off 16 sts. then remove the remaining sts. on W.Y.

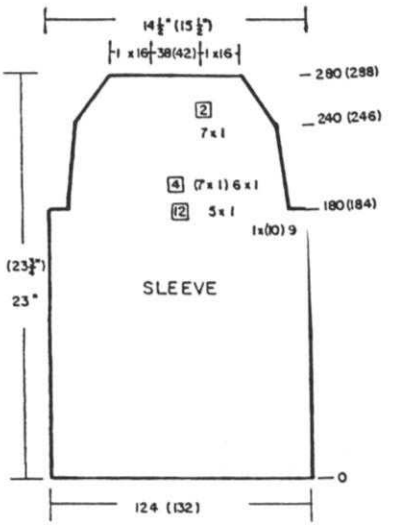

JACKET FRONT:

With W.Y. cast on same as Back 100 (106) sts. After Ravel Cord Row, change to garment yarn. Counter 0. ON SIDE EDGE, inc. 1 st. every 10th row 6 (7)x. After R 100 (106), ON ARMHOLE SIDE, bind off 10 (11) sts. then bind off 4 sts. 1x, dec. 1 st. EOR 7 (8)x. After R 176 (182) SHAPE NECK: Bind off 8 (9) sts. 1x, 4 sts. 2x, 1 st. EOR 7 (9)x. After R 206 (216), bind off the remaining sts. or remove on W.Y.

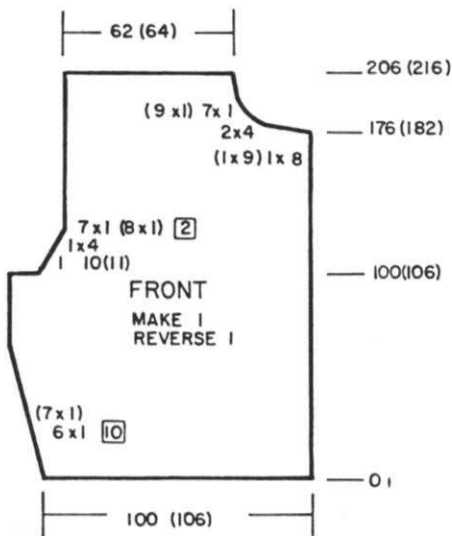

SLEEVE CUFFS

Bring to WP 52 (56) Ndl. Hang the open sts. of sleeve onto these Ndl. decreasing evenly across. Continue St. st. to R 46. Pick up the first row to form hem and bind off.

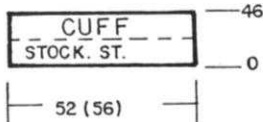

BOWS: Make 3

FNR: T 3/2.1 I - Cast on 11 st. Set Carriages for Circular knitting. Knit 300 rows. Remove on W.Y.. Close tube ends.

BOW MAKE 3

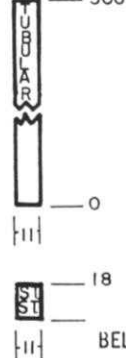

CENTER KNOT FOR BOWS Make 3

St. st. T 4.2. Cast on 11 st. NOTE: cast on by bringing EO Ndl. to E position (as for hem cast on). Push in BOTH PART BUTTONS. Knit 1 row. Release Part Buttons (this prevents sts. from running). Knit 18 rows. DO NOT BIND OFF. Break yarn and thread into tapestry needle. Take the sts. off onto this strand of yarn. Wrap this strip around center of Bow, join ends and pull tight.

BELT:

FNR: T 2/2 I. Cast on 5 sts. Knit to desired length. Bind off.

SLEEVE PUFF: Make 2.

St. st. T 10. Cast on 70 sts. Knit first row over EO Ndl. same as you did for center Knot. Knit 50 rows. Leave long end and break yarn. Thread into Tapestry Needle and remove the sts. onto strand of yarn. Pull up the sts. on this end and also the cast on end. Form a soft semi circle roll. Secure each end.

SKIRT BACK:

Begin with Ndl. 5 on the RIGHT of 0 and with W.Y. cast on 78 (83) sts. same as you did for back. End with Ravel Cord to the LEFT. Work the SHORT ROWS ON THE RIGHT SIDE ONLY same as front and work the increases on the RIGHT. After R 93, Put these sts. into HP (or remove them onto W.Y. if you prefer). Leave 4 empty Ndl. to the LEFT of 0 and with W.Y. cast on 78 (83) sts. to the left of the empty Ndl. After waste knitting end with 1 row Ravel Cord to the RIGHT. Work the SHORT ROWS ON THE LEFT SIDE ONLY same as front and work the increases on the LEFT. After R 93, 'e' cast on over the center 8 empty needles. Bring all needles to WP (or if you removed the right section on W.Y. hang the sts. back onto the machine. You can use an 8 st. cast on rag for the 8 center sts. or if you cast them on, be sure to bring them to E position for several rows so they will knit off. Hang a small weight in the center of knitting. Counter 93, Carriage on left. Work over all sts. and complete same as the front. After R 300 (312), remove onto W.Y. (MARK CENTER).

SKIRT FRONT: Omit Slit.

With W.Y. cast on 164 (174) sts. Knit several rows ending with 1 row Ravel Cord to the right. Change to Garment yarn. Counter 0. Work St. st. and Short Rows. ON OPPOSITE SIDE OF CARR. bring to HP 48 sts. before knitting next 2 rows (be sure to always wrap inside Ndl. to prevent hole when knitting short rows). ON OPPOSITE SIDE OF CARR. push back to WP 16 sts. then 32 sts. ON EACH SIDE. Continue over all Ndl. in St.st. ON EACH SIDE, increase 1 st. every 10th row 10x. After R 260 (272), ON EACH SIDE, dec. 1 st. every 8th row 5x. After R 300, (312), remove on W.Y.

SKIRT FRONT LOWER BAND:

Bring to WP 131 (141) Ndl. With wrong side facing, hang the open sts. of Skirt bottom onto these Ndl. as follows: ON EACH SIDE, hang 2 sts. together 4x. then hang every 5th & 6th st. together on 1 Ndl. Knit 16 rows St. st. Pick up the first row of band to form hem. Bind off.

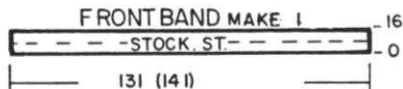

NEXT - Make Edging for slit in back of Skirt. - Make 2. Bring 52 Ndl. to WP. With wrong side facing, hang one edge of slit onto these Ndl. Knit 16 rows St. st. Pick up the first row of band to form hem. Bind off. REPEAT for other side of slit.

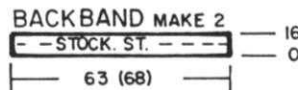
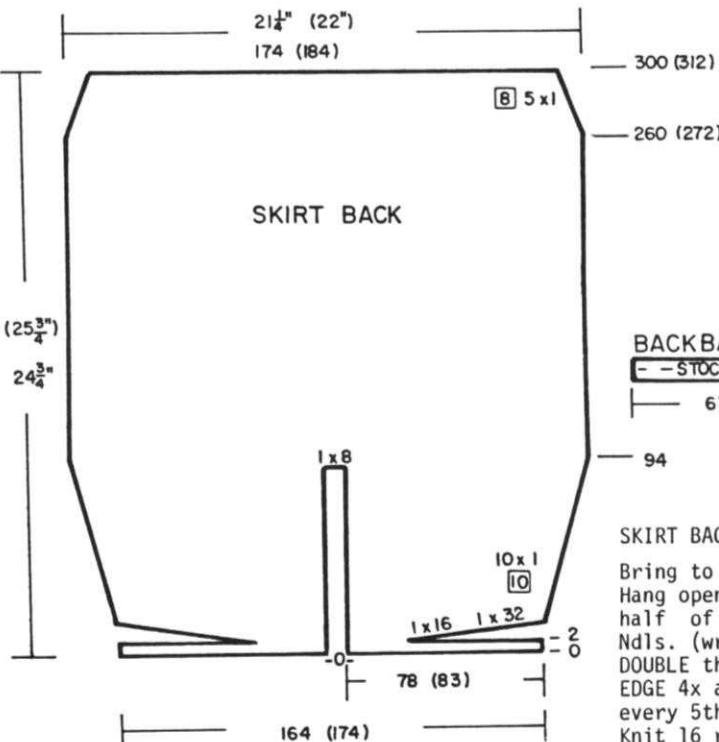

SKIRT BACK LOWER BAND:

Bring to WP 63 (68) Ndl. Hang open stitches from one half of back onto these Ndl. (wrong side facing). DOUBLE the sts. on SIDE EDGE 4x as before, then every 5th & 6th st. together. Knit 16 rows St. st. Pick up the first row to form hem. Bind off.

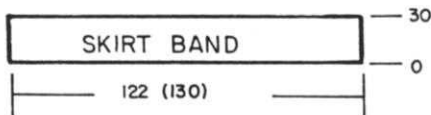

WAISTBAND: Make 2.

Bring to WP 122 (130) Ndl. With wrong side facing, hang 1 skirt section as follows: Beginning on right edge, hang first 15 (16) sts. *Skip next st. hang next st, on next Ndl. Hang the next 2 sts. on SAME NDL. Hang the SKIPPED ST. on SAME NDL. (4 sts. on 1 Ndl.).** REPEAT FROM * 2x MORE. Hang the next 12 sts. REPEAT FROM * to ** 3x. Pick up the next 12 sts. REPEAT FROM * to ** 3x. Pick up the next 26 sts. REPEAT FROM * to ** 3x. Pick up next 12 sts. REPEAT FROM * to ** 3x. Pick up next 12 sts. REPEAT FROM * to ** 3x. Pick up the last 15 (16) sts. Knit 30 rows Stockinette st. Pick up the first row of band to form hem. Bind off.



CONTINUED

FINISHING: See General Instructions. Make Bows and attach (See Photo for placement). The front section of Jacket is pleated at shoulders (make 2 pleats on each side, evenly spaced). The sleeves are puffed at top. Attach separate sleeve Puffs to inside at shoulder. Insert shoulder pads. Sew in zipper by hand above the front peplum (See picture).

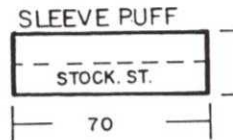
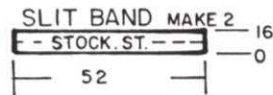

555

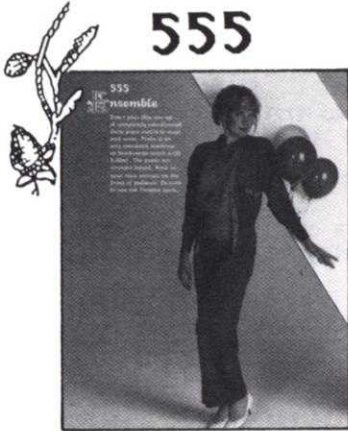

WOMENS 3 PIECE ENSEMBLE

SIZES: 6/8 (10/12) [14/16]
YARN: Venetia
AMOUNT:
 Col. 1 2 lbs. 8 oz. all sizes.
 Col. 2 1 lb. for all sizes.
TENSION: St. st. 4.2 Rib 2/1.1 II
GAUGE: 17 sts. 24 rows = 2"
NOTIONS: Shoulder Pads, 7 Buttons
 5/8" for Jacket and 1 Button
 1/2" for back neck of Top.
 1" Elastic for waist of Slacks.

Make on any standard Machine with Ribber. Optional Logo on sleeveless Top was made with Duplicate St.

JACKET FRONT BAND: Made in 1 continuous strip.

FNR: With Col. 2, cast on 11 sts. (MB 11 st. Rib. Bed 10 sts.) T 5/4.2 II After Selvedge. Put Counter to 0 and knit 4 rows. Follow Chart for placement of VERTICAL BUTTONHOLE over the next 5 rows. See your Instruction Manual for knitting vertical buttonholes. Make 4 MORE buttonholes in the same way after the rows shown on Chart. After R 323 (336) [349] mark edge with bit of W.Y. and after R 387 (400) [413], mark edge again. The marks are for placement of band across back of neck. After R 710 (736) [762], transfer Rib sts. to MB and bind off

JACKET FRONT BAND

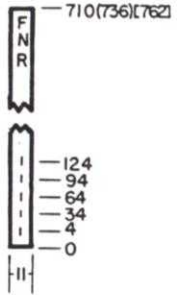

POCKET EDGE



POCKET TRIM: Make 2

FNR: With Col. 2, cast on 9 sts. on MB, 8 sts. on Rib. T 5/4.2 II. Knit 50 rows. Transfer Rib sts. to MB and bind off.

JACKET BACK:

K1, P1 Rib: With color 1, cast on 169 (179) [189] sts. Knit 112 (116) [120] rows. Transfer Rib sts. to MB. Add 1 st. on the right. Continue in St. st. After R 214 (216) [218], ON EACH SIDE, mark with W.Y. for setting in sleeves. After R 324 (332) [340] SHAPE SHOULDER: ON EACH SIDE, bind off (or use Short Rows) 6 sts. 3x. Mark with W.Y. for neck opening and bind off or remove onto W.Y.

FRONT: Make 1, reverse 1.

Make 2 Pocket Linings FIRST. With W.Y. cast on 34 sts. Knit several rows ending with 1 row Ravel Cord to the right. Change to Col. 1 and work 46 rows St. st. Remove onto W.Y. Make another Pocket Lining the same.

K1, P1 Rib: With Col. 1, cast on 85 (89) [95] sts. Knit to R 112 (116) [120]. Transfer Rib sts. to MB and add 1 st. on the right. Continue in St. st. Knit to R 158 (162) [166]. SEE CHART FOR PLACEMENT OF POCKET and bind off or remove onto W.Y. 34 sts. Hang open sts. from top edge of Pocket Lining onto these empty Nds. AT THE SAME TIME SHAPE NECK: ON NECK SIDE, dec. 1 st. every 6th row 23 (24) [26]x. After R 324 (332) [340] SHAPE SHOULDER same as Back. After R 330 (338) [346], bind off remaining sts.

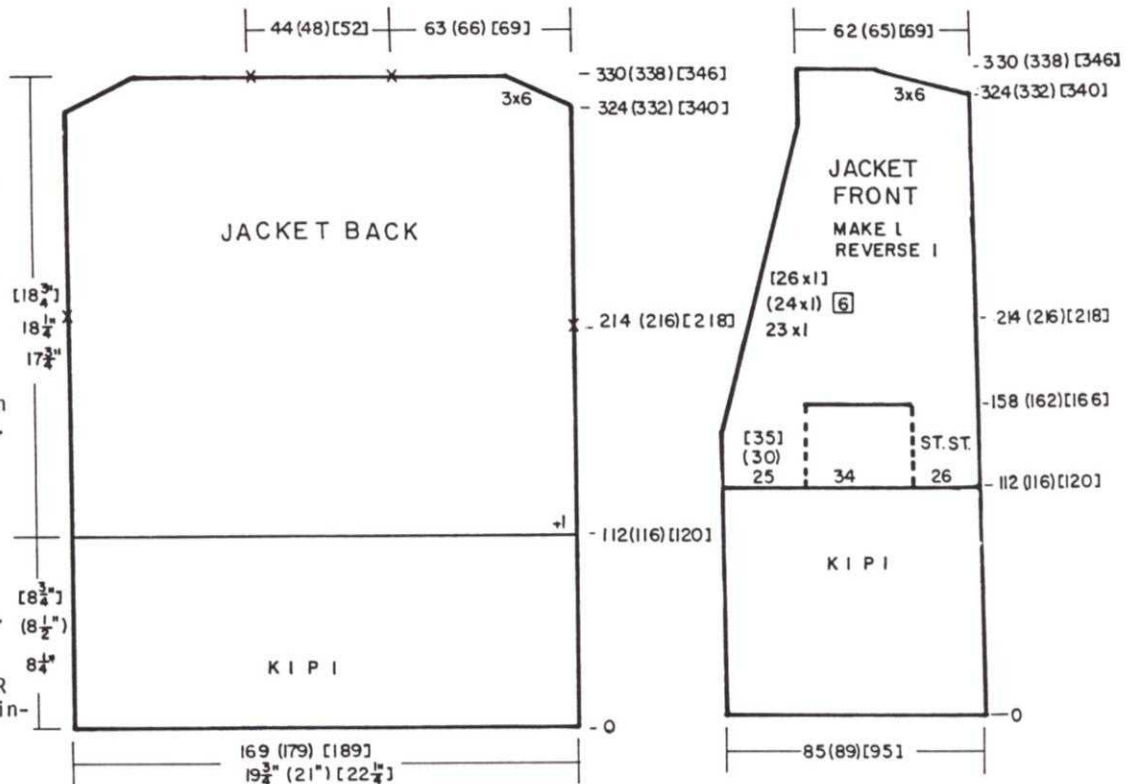

SLEEVES:

With W.Y. cast on 92 (98) [104] sts. After several rows, end with 1 row Ravel Cord to the right. Counter 0. Change to Color 1 and continue in St. st. ON EACH SIDE, increase 1 st. every 5th row 31 (33) [35]x. After R 168 (174) [180], bind off or remove onto W.Y.

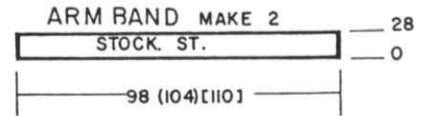
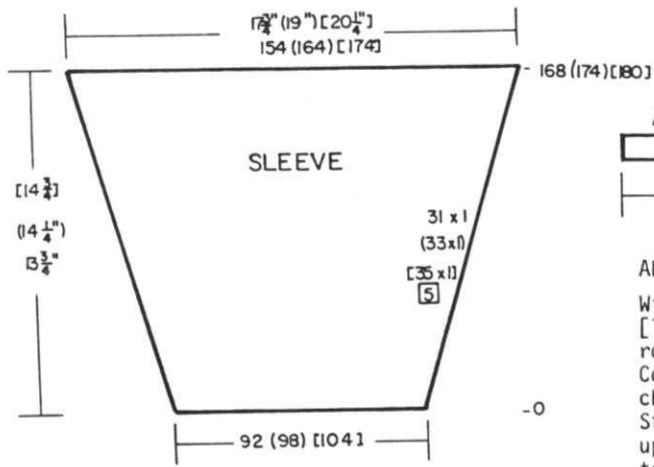

ARMBANDS:

With W.Y. cast on 98 (104) [110] sts. After several rows end with 1 row Ravel Cord to the right. Counter 0, change to Col. 2. and knit St. st. Knit to R 28. Pick up the first row of knitting to form hem. Knit 1 row and remove onto W.Y.

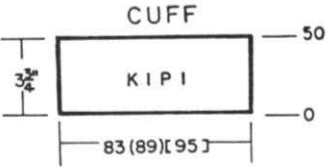

SLEEVE CUFFS:

K1, P1 Rib: With Col. 1, cast on 83 (89) [95] sts. Knit 50 rows. Transfer Rib sts. to MB. Hang open sts. of lower sleeve edge onto these Ndl., decreasing evenly across. Bind off.

SLEEVELESS TOP: BACK:

K1, P1 Rib: With color 1, cast on 153 (163) [173] sts. Knit to R 74 (78) [82]. Transfer Rib sts. to MB. Add 1 st. on right side. Continue St. st. Knit to R 184 (188) [192]. ON EACH SIDE, inc. 1 st. EOR 3x. After R 262 (266) [270], divide in center. Put sts. on the left into HP and complete the right side first. *Knit to R 272 (280) [288]. SHAPE SHOULDER: Bind off 6 sts. 9x, 3 sts. 1x (6 sts. 10x) [6 sts. 9x, 9 sts. 1x]. Bind off the remaining sts. Bring the Ndl. on the left back to WP. Turn Row Counter back to 262 (266) [270] and complete the left half. Follow instructions from *.

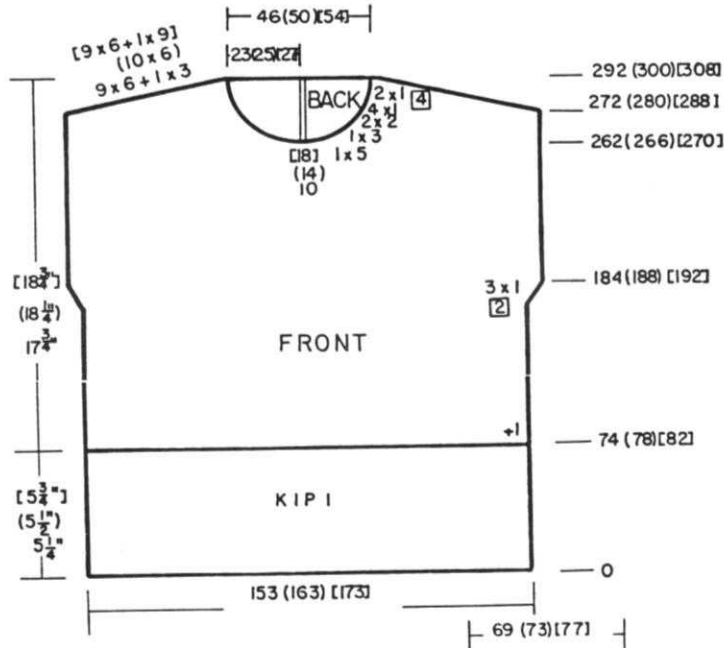

SLEEVELESS TOP: Front:

K1, P1 Rib. With Col. 1, cast on and knit same as back to R 262 (266) [270]. Bind off the center 10 (14) [18] sts. for neck. Put the Ndl. on the left into HP and complete the right side first. *Follow Chart for front neck bind offs AND AT THE SAME TIME after R 272 (280) [288], SHAPE SHOULDER same as the back. Bring the Ndl. on the left to WP, Counter back to 262 (266) [270] and complete the left half. Follow instructions from *.

SLACKS BACK. Make 1. reverse 1.

With W.Y. cast on 94 (100) [106] sts. After several rows end with 1 row Ravel Cord to the right. Counter 0. Change to Col. 1 and knit St. st. After R 270 (276) [282], ON THE RIGHT, increase 1 st. every 4th row 9 (10) [11]x. After Row 306 (316) [326] ON THE RIGHT, bind off 3 (3) [5] sts. 1x PLEASE FOLLOW THE DIFFERENT SHAPINGS ON EACH SIDE AS SHOWN ON THE CHART. After R 432 (450) [468], SHAPE TOP using Short Rows. ON OPPOSITE SIDE OF CARR. bring to HP 30 sts. 1x, then on EOR, 20 sts. 1x, 12 sts. 1x. (See Chart). Push all the sts. back to WP and knit 2 rows. Bind off or remove on W.Y. Make second half of back with reverse shaping and to make it easy for you, have the EVEN NUMBERS on COUNTER on the LEFT SIDE instead of right.

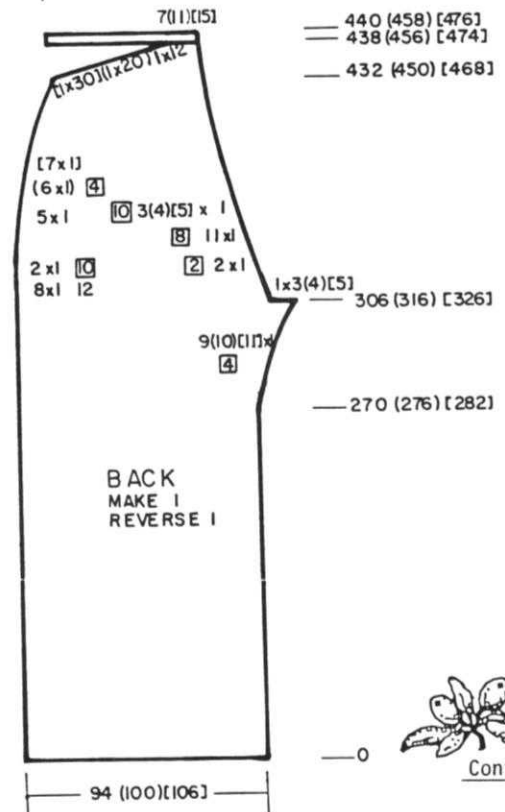

COLLAR: Make 2

FNR: With Col. 2, cast on 60 sts. T 4.1/3.2 II. Make 9 rows circular knitting. Change Tension to 5/4.1 II and knit to R 49. Transfer Rib sts. to MB. Knit 1 row T 3 over all sts. Change Tension to 2/1.1 II and with transfer tool, transfer every other st. to the Ribber for K1, P1 Ribbing. Knit 5 rows. Transfer Rib sts. to MB and remove on W.Y. REPEAT FOR SECOND HALF OF COLLAR.

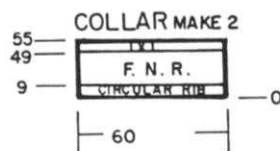

Continued

SLACKS FRONT: Make 1, reverse 1.

Cast on same as Back and follow the Chart for the shapings on each side. After R 434 (452) [470], bind off or remove onto W.Y.

Join the 2 sections of back together from waist to crotch. Join the front sections in the same way. Join the INNER seams of slack legs, leaving the sides open so you can make the Cuffs and Waistbands.

CUFFS: Make 2.

Bring 148 (160) [172] Ndl. to WP. With wrong side facing, hang the open sts. of leg onto these Ndl. decreasing evenly across.

With Color 1, knit 28 rows St. st. Pick up the first row to form hem and bind off.

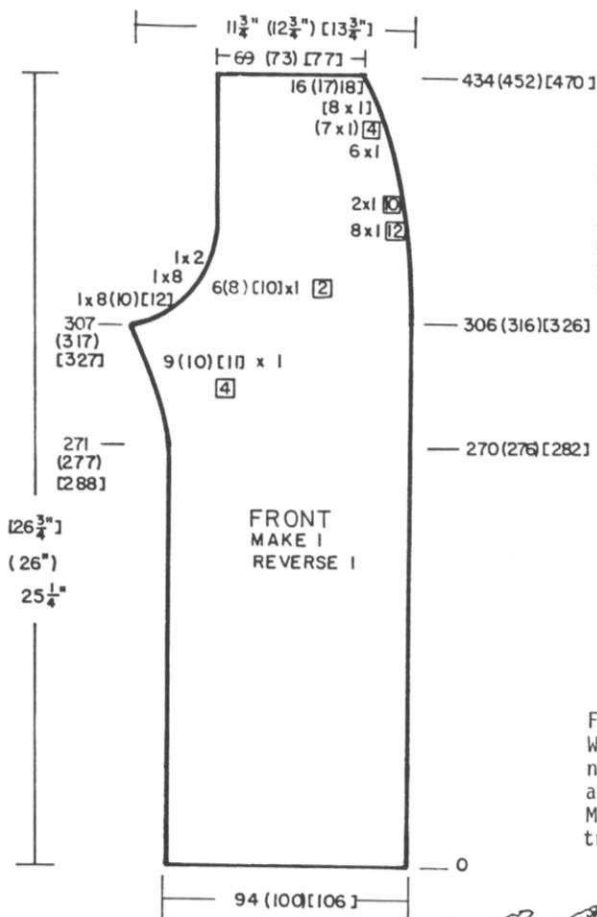
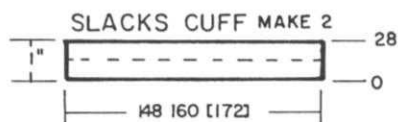

WAISTBAND: Make 2.

Bring 116 (122) [128] Ndl. to WP. With wrong side facing, hang the front waist edge onto these Ndl. decreasing evenly across. With Col. 1, knit 30 rows St. st. Pick up first row to form hem. Bind off loosely. REPEAT FOR BACK BAND.

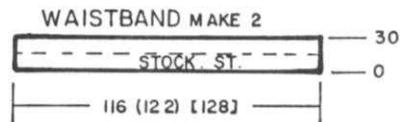

FINISHING: See General Instructions. Weave the Collar sections of Top to neck edge. Work 1 row single crochet around Collar and back neck opening. Make 1 loop for button. Attach pocket trim to top of pockets.

556



BACK:

K1, P1 Rib: With Col. 1, cast on 85 (97) sts. Knit 30 rows. Transfer Rib. sts. to MB. Add 1 st. on the right side.

Begin the INTARSIA DESIGN.

After R 114 (120), SHAPE ARMHOLE: ON EACH SIDE, Make FULL FASHION DECREASES. 1 st. 1x, then every 6th row, 2 sts. 5 (6)x.

After R 180 (192) SHAPE SHOULDERS: ON EACH SIDE, bind off or use Short Rows, 6 sts. 3x (6 sts. 2x, 8 sts. 1x).

After R 186 (198), bind off or remove onto W.Y. the remaining sts.

CHILDS INTARSIA CARDIGAN

SIZES: 3/4 (5/6)

YARN: Amore

AMOUNT:

Col. 1 4 5 balls

Col. 2, 3, 4, 5, 6 - 1 ball each

If knitting the set, there is sufficient yarn left from the Mother's Cardigan to cover the multiple colors.

TENSION: 6 St. st. Rib. 4/3.1 II

GAUGE: 14 sts. 28 rows = 2" (5 cm)

Make on any standard Machine with Ribber. Use INTARSIA CARRIAGE for Design. Bands are K1, P1 Ribbing. For a full size Chart of the Intarsia Designs, send \$1.00 and a self addressed, stamped envelope.

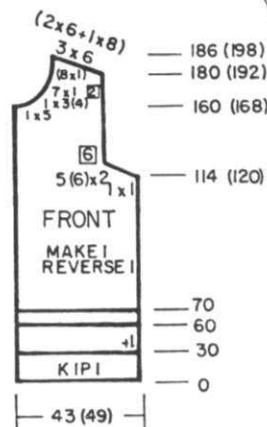

FRONT: Make 1, reverse 1.

K1, P1 Rib: With Col. 1, cast on 43 (49) sts. Continue same as Back to R 30 then begin the INTARSIA DESIGN for Front. After R 114 (120) SHAPE ARMHOLE same as Back. After R 161 (169) bind off 5 sts. 1x for Neck then follow Chart for decreases in the size you need. After R 180 (192) SHAPE SHOULDER same as Back.

FRONT BANDS; Make 2, 1 without Buttonholes.

K1, P1 Rib: With col. 1 cast on 105 (111) sts. Knit 6 rows. Make 5 Buttonholes over 2 Ndl. (both beds) as shown on the Chart. After R 22, REPEAT BUTTONHOLES over same Ndl. After R 28, transfer Rib sts. to MB. Knit 1 row St. st. With wrong side facing, pick up sts. along front edge (Buttonhole band on right front) and bind off.

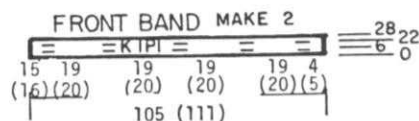
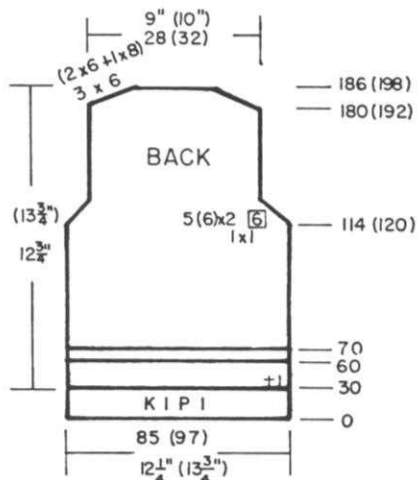

SLEEVES:

K1, P1 Rib: With Col. 1 cast on 55 (66) sts. After R 30, transfer Rib sts. to MB. Add 1 st. on the right. Follow the INTARSIA DESIGN. After R 70, ON EACH SIDE, increase 1 st. every 10th row 5x (every 9th row 6x). After R 114 (118), SHAPE CAP: ON EACH SIDE, Full Fashion Decreases, 2 sts. every 8th row 7x, 1 st. every 4th row 1x (2x). After R 176 (184), ON EACH SIDE, work Short Rows 4 sts. 3x on each side. Knit 2 rows over all sts. then bind off.

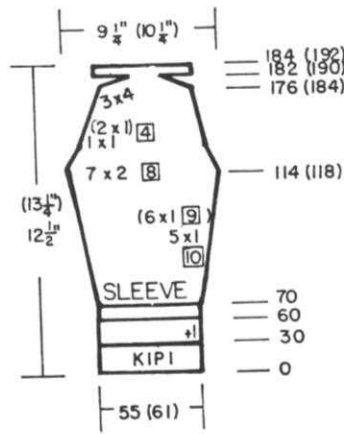

NECKBAND:

Join shoulders first. K1, P1 Rib: With Col. 1, cast on 85 (91) sts. Knit 6 rows. Starting 4 sts. from LEFT end, make 1 BUTTONHOLE over 2 Ndl's. (each bed). Knit to R 22. REPEAT BUTTONHOLE over same Ndl's. After R 28, transfer the Rib sts. to MB. Pick up first row to form hem. Knit 1 row, then with wrong side facing you, pick up sts. around neckline evenly placed and bind off.

FINISHING: See General Instructions.

WOMENS INTARSIA CARDIGAN

SIZES: 38/40 (44/46)
YARN: Amore

AMOUNT:
Col. 1 5 6 balls
Col. 2, 3, 4, 5, 6 - 1 ball each
TENSION: 6 St. st. Rib 4/3.1 II
GAUGE: 14 sts. 24 Rows = 2" (5 cm)

Make on any Standard Machine. Use INTARSIA CARRIAGE for the Designs. Bands are K1, P1 Ribbing. For a full size Chart of the Intarsia Designs, send \$1.00 and a Self addressed, stamped envelope.

BACK:

K1, P1 Rib: With Col. 1, cast on 145 (163) sts. Knit to R 36. Transfer Rib sts. to MB. Add 1 st. on the right. Follow the Chart for INTARSIA DESIGN. After R 192 (198) SHAPE ARMHOLE: ON EACH SIDE, Full Fashion decreases, 2 sts. every 4th row 10 (11)x. After R 292 (306) SHAPE SHOULDER: ON EACH SIDE, bind off 6 sts. 4x, 7 sts. 1x (7 sts. 3x). After R 302 (316), bind off remaining sts.

FRONT: Make 1, reverse 1

K1, P1 Rib: With Col. 1, cast on 73 (81) sts. After R 36, transfer Rib sts. to MB. Add(1)st. on right. Follow Chart for INTARSIA DESIGN. After R 270 (278), SHAPE NECK: Follow the neck bind offs for your size as shown on Chart. After R 292 (306), SHAPE SHOULDER same as back.

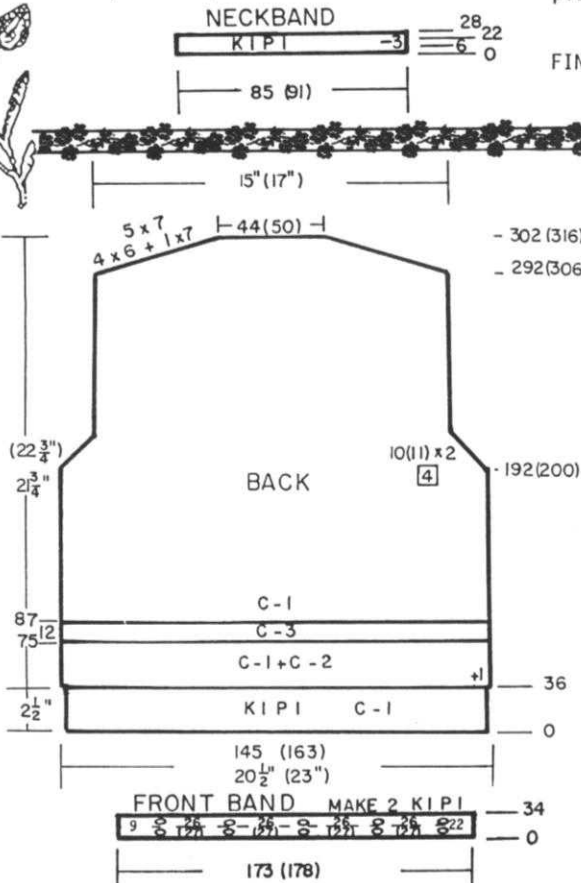

FRONT BANDS: Make 2, 1 without Buttonholes.

K1, P1 Rib: With Col. 1, cast on 173 (178) sts. Knit 8 rows. MAKE BUTTONHOLES over 2 Ndl's. (both beds). See Chart for placement of Buttonholes. Knit to R 26 and REPEAT BUTTONHOLES. After R 34, transfer Rib sts. to MB. Pick up first row of knitting to form hem, knit 1 row. With wrong side facing, pick up sts. along front edge (be sure buttonhole band is on right front). Bind off.

NECKBAND: Make 1.

Close shoulders first. K1, P1 Rib: With Col. 1, cast on 119 (131) sts. Knit to R 8. Make single Buttonhole on left (both beds). After R 26, REPEAT BUTTONHOLE over same Ndl's. After R 34, transfer Rib sts. to MB. Pick up first row of knitting to form hem, knit 1 row. With wrong side facing, pick up sts. along neckline (evenly). Bind off.

SLEEVES:

K1, P1 Rib: With Col. 1 cast on 71 (75) sts. After R 36, transfer Rib sts. to MB. Add 1 st. on right. Follow the Chart for INTARSIA DESIGN and AT THE SAME TIME, ON EACH SIDE, inc. 1 st. every 9th row 15 (17)x. After R 186 (192) SHAPE CAP: ON EACH SIDE, make Full Fashion Decreases. Dec. 2 sts. then 2 sts. every 4th row 1 (2)x more then every 8th row, dec. 2 sts. 10x. After R 274 (286) Work Short Rows ON EACH SIDE, 2 sts. 1x, 4 sts. 1x, 8 Sts. 1x. After R 280 (292) Knit 2 rows over all sts. then bind off.

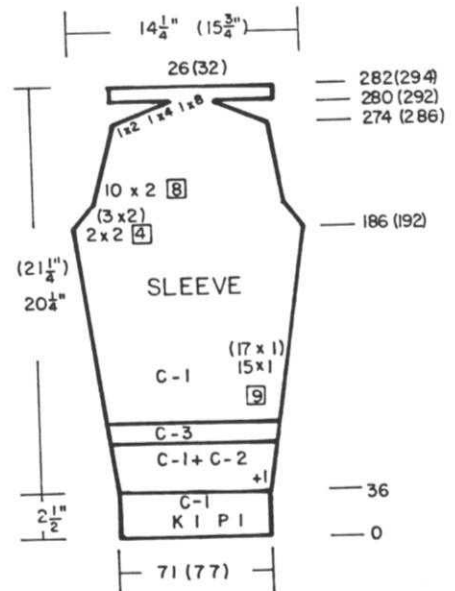

NECKBAND



FINISHING:

See General Instructions. Finish Buttonholes and sew on Buttons. Fold Sleeve Cuff to the inside and sew in place.

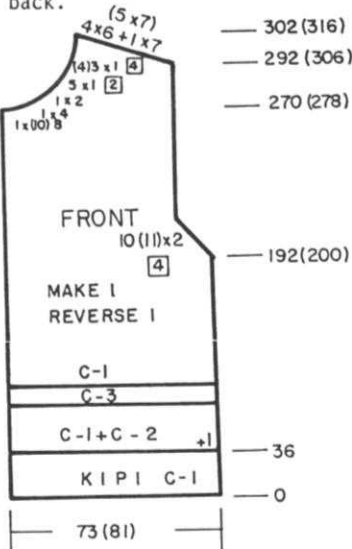



WOMENS EVENING JACKET & SKIRT

SIZES: 8/10 (12/14)
YARN: Venetia = Col. 2
 Capriccio = Col. 1

AMOUNT:
 Col. 1 11 balls for all sizes.
 Col. 2 3 lbs. for all sizes.

TENSION: Jacket - 5/4 I
 Skirt - 7.2/5.2 I

GAUGE: Jacket - 15 sts. 48 R = 2"
 Skirt - 18 sts. 16.5 R = 2"

Make on any Electronic Machine with Ribber and KRC COLOR CHANGER. Jacket front has isolated Fair Isle Design. Skirt is a variation of K 2, P 2 Rib.

Set COLOR CHANGER (KRC) to Machine. Thread Col. 2 (Venetia) into Button 2 of KRC. Add Fine Knitting Bar to main bed.

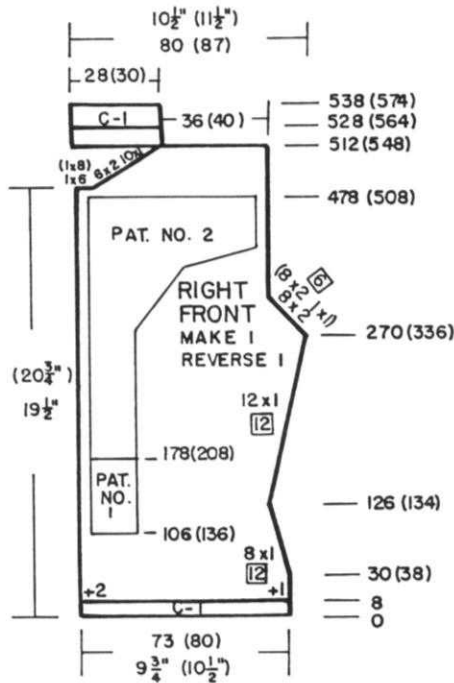

RIGHT 38 ← 0 → 35
 FRONT (38) ← → (42)

LEFT 35 ← 0 → 38
 FRONT (42) ← → (38)

JACKET FRONT: Make 1, Reverse 1.

With Col. 1 and using placement according to diagram below Chart, Cast on FNR 73 (80) sts. Tension 0/0 I. After perfect selvedge, inc. 2 sts. on LEFT SIDE, 1 st. on RIGHT SIDE. (Reverse for other side). ON MB ONLY, change Tension to 1/1 II. Continue with Col. 1 and knit 4 rows circular. Set Counter to 0. With T 1/1 I, Col. 1, knit 6 rows FNR. End with Carr. on Far LEFT. SET MAIN MACHINE TO KC II. SET RIBBER WITH BOTH PR BUTTONS UP. With T 5/4 I, knit 1 R from LEFT TO RIGHT. PUSH IN BOTH PART BUTTONS. Knit 1 row RIGHT to LEFT. CHANGE TO COL. 2. Release PR Buttons on Ribber (Push down to bottom position). Knit 2 rows. Change to Col. 1, Push BOTH PR BUTTONS UP. Knit 2 rows. REPEAT this throughout - 2 ROWS COL. 1, BOTH PR BUTTONS UP. 2 ROWS COL. 2, BOTH PR BUTTONS DOWN.

PART BUTTONS ON MAIN MACHINE REMAIN PUSHED IN THROUGHOUT. ALSO: When knitting with KC II, end needles are NOT selected, therefore, ON EVERY ROW, bring the end needles to 'E' Continue in this way to R 30. ON SIDE EDGE, dec. 1 st. every 12 rows 8x. (See Chart). After R 106 (136), Begin Pat. 1 and AT THE SAME TIME, after R 126 (134) ON SIDE EDGE, increase 1 st. every 12th row 12x. After R 178 (208) begin Pat 2 BUT AT THE SAME TIME, after R 270 (336) SHAPE ARMHOLE: ON ARMHOLE SIDE, dec. 2 sts. every 6th row 8x, (8 x 2 + 1 x 1).

After completing Pat. 2 after Row 478 (508), start NECK SHAPING. DO NOT BIND OFF STS. FOR NECK DECREASES. Use Ravel Cord. Example: We say Dec. 8 sts. on Neck edge. This means to knit back to 'A' position 8 sts. on MAIN BED AND 8 sts. on RIBBER BED.

Begin decreases on NECK EDGE: 6 (8) sts. 1x, 2 sts. EOR 6x, 1 st. EOR 10x. After R 512 (548) transfer the 36 (40) RIBBER shoulder sts. (See Chart) to MB and bind off. Now bring the Neck edge sts. held on Ravel Cord back to WP. Make sure MB and Ribber Carriages are set and continue with 2 rows Col. 1, 2 rows Col. 2 (same as before). After R 528 (564) change to Col. 1 ONLY and knit to R 538 (574). Transfer the Ribber sts. to MB and bind off.

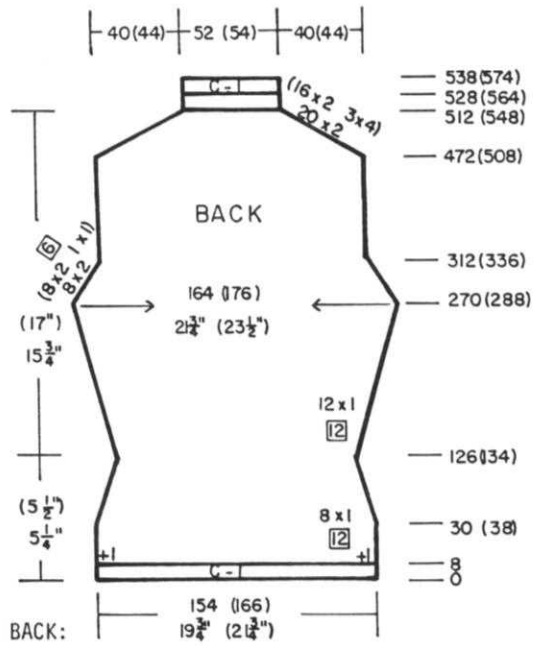

BACK: Cast on same as FRONT but inc. 1 st. only on each side on the MB only. When you set MB Carriage, use KC I as there is no Fair Isle Pat. See Chart for decreases and increases. Knit in same technique as Front (2 rows Col. 1, 2 rows Col. 2 with PR Buttons up and down. After R 472 (508) SHAPE SHOULDER: ON EACH SIDE bind off 2 sts. EOR 20x (4 sts. 3x, 2 sts. 16x). BE SURE TO TRANSFER THE RIBBER STS. FIRST, then make the bind offs. After R 512 (548) continue with Col. 1 and Col. 2 to R 528 (564). Change to Col. 1 ONLY and knit to R 538 (574). Transfer Ribber sts. to MB. Bind off.

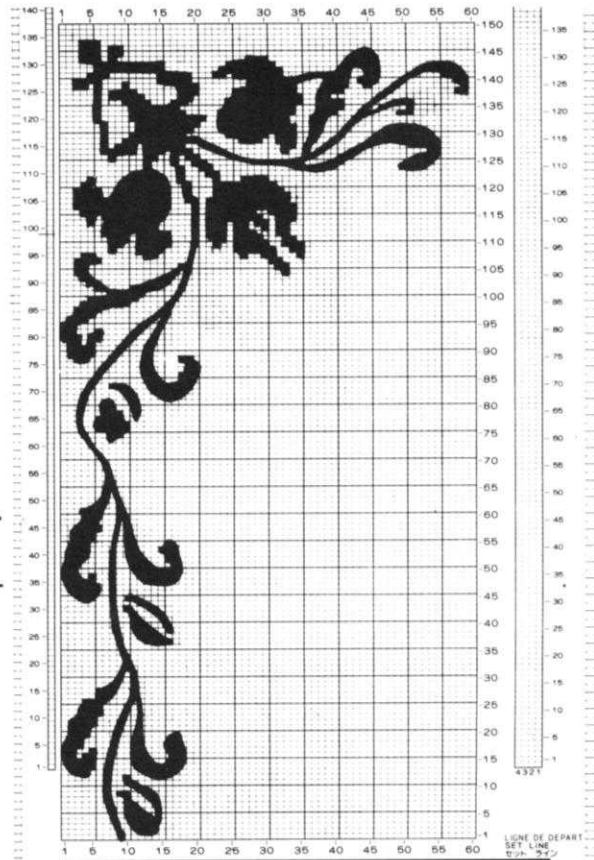

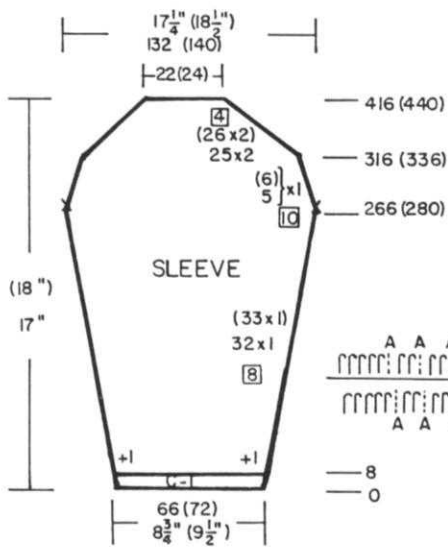

SLEEVES:

FNR: With Col. 1 cast on 66 (72) sts. same as you did for Front and Back. ON EACH SIDE, inc. 1 st. on MB ONLY.
 Set to KC I on Main Machine and knit same as before.
 ON EACH SIDE, increase 1 st. every 8th row 32 (33)x.
 After R 266 (280), mark each side with W.Y. SHAPE CAP: ON EACH SIDE (transfer Ribber sts. to MB before binding off) decrease 1 st. every 10th row 5 (6)x then 2 sts. every 4th row 25 (26)x (See Chart). After R 416 (440), bind off the remaining sts.

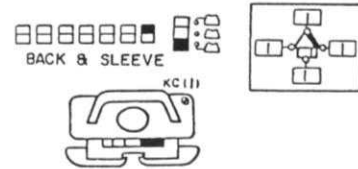
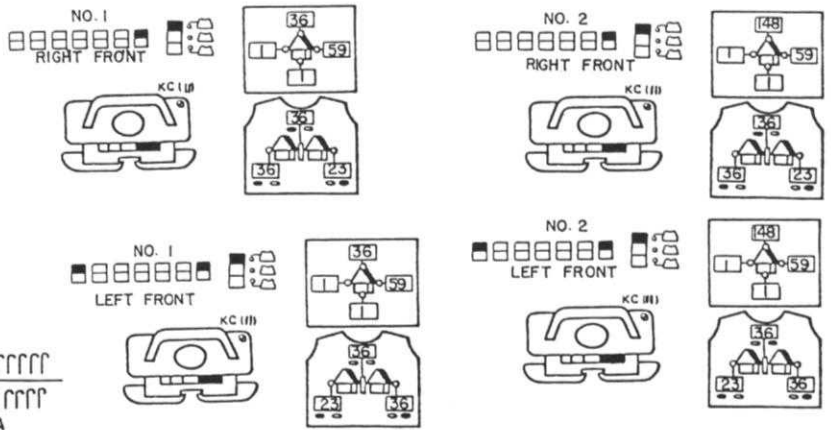

* FOR FULL SIZE COPY OF DESIGN, SEND \$1.00 plus self addressed stamped envelope.

SKIRT: Make 2 Panels

FNR: Cast on 184 (196) sts. With T 3/3 I knit 5 rows circular. Transfer MB sts. and Ribber sts. to form needle arrangement as per Chart.
 Knit to R 392 (410) following Tension changes as shown on Chart. Remove onto W.Y.

WAISTBAND:

Bring to WP 124 (132) Ndls. Hang the open sts. of Skirt Waist onto these Ndls. doubling every 2nd & 3rd st.
 Knit 24 rows St. st. Hang the hem and bind off.

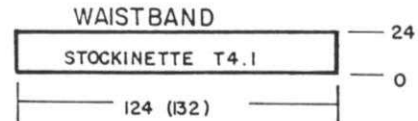

FINISHING:

See General Instructions.

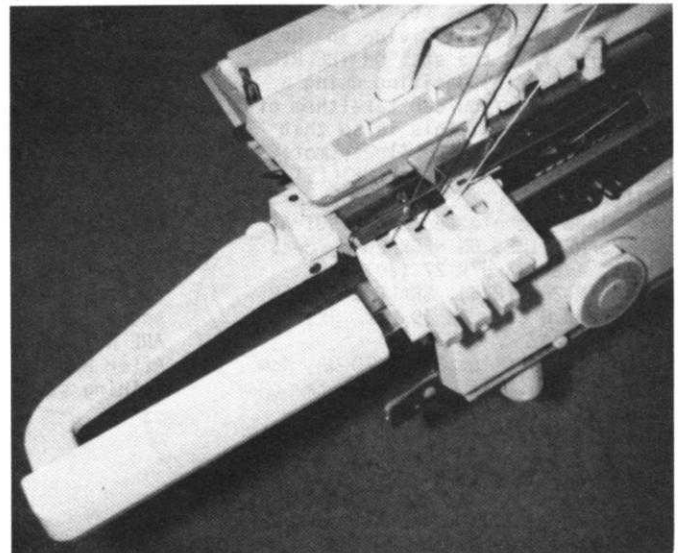
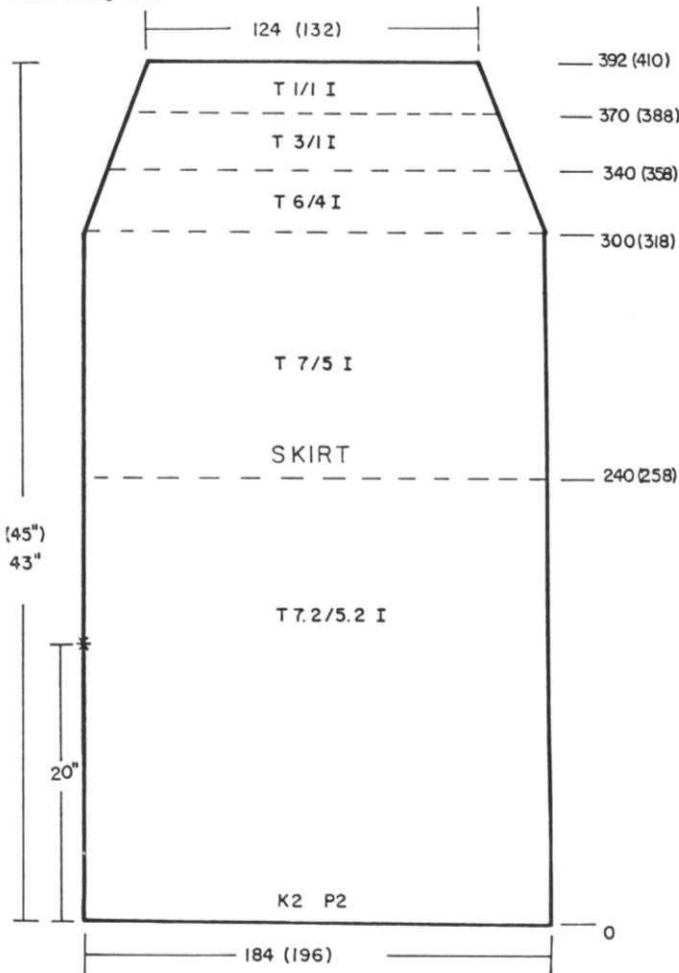

NEW KRC 900 COLOR CHANGER....
 Suitable for all machines from the KH 830 through the COMPUKNIT III (KH 930) plus the KH 260 BULKY... all with Ribber.
 PRICE \$109.95 - F.O.B. Los Angeles...



BACK: Col. 1

K1, P1 Rib: Cast on 149 (159) sts. Knit 40 Rows. Transfer Rib sts. to MB. Add 1 st. on right side. Continue St. st. to R 176 (182). SHAPE ARMHOLE: ON EACH SIDE, dec. 1 st. EVERY ROW 9 (10)x, 1 st. EOR 4x, 1 st. EVERY 4th R 3x. After R 266 (276), SHAPE NECK: Bind off the center 30 (34) sts. Place sts. on LEFT into HP. and complete the right side first. *ON NECK EDGE, bind off 6 sts. 1x, 4 sts. 1x, 2 sts. 1x, but AT THE SAME TIME, SHAPE SHOULDER: Bind off 8 sts. 4x (9 sts. 3x, 7 sts. 1x). Bring the sts. on left to WP. Turn Counter back to 266 (276) and complete left half following the instructions from *.

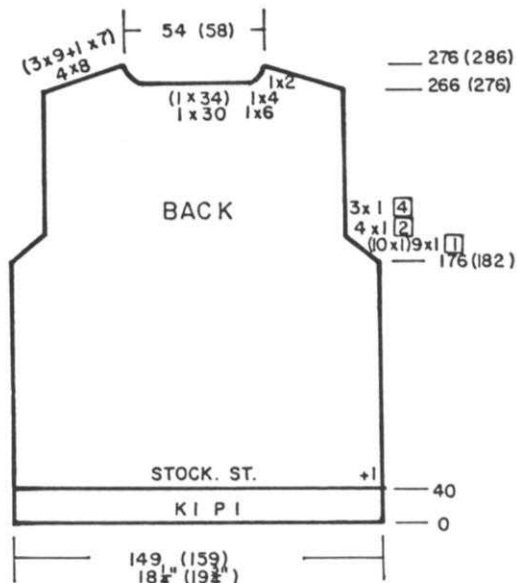

WOMENS SKIRT & TOP

SIZES: 10/12 (14/16)
 YARN: Venetia = Col. 1
 Isabella = Col. 2
 Angora = Col. 3

AMOUNT:
 Col. 1 2 lbs. all Sizes
 Col. 2 1 ball all Sizes
 Col. 3 1 ball all Sizes
 TENSION: St. st. 5.2 Rib. 0/0 I
 GAUGE: 16 sts. 24 R = 2" (5 cm)
 14 sts. 20 R for Lace = 2"
 21 sts. 23 R for Skirt "

Make on any Electronic Machine with GARTER CARRIAGE and Lace Carriage. Flowers are Single Motif.

TOP FRONT:

K1, P1 Rib. With Col. 1 cast on 157 (167) sts. Knit 40 rows. Transfer Rib sts. to MB. Add 1 st. on Right. Continue in St. st. After R 61 (67) Set Program for Pattern No. 1. After R 131 (137) Set Program for 2nd Motif. Cont. in Pat. After R 176 (182), SHAPE ARMHOLE: ON EACH SIDE, bind off 6 (7) sts. 1x, then EVERY ROW, dec. 1 st. 7x and EVERY 2nd R dec. 1 st. 7x. After R 190 (196), divide in the center. Knit the sts. ON THE RIGHT BACK TO NWP (A) position using a Ravel Cord or you can take them off onto waste yarn. This is so that you can complete the flower motif on the LEFT. COMPLETE THE LEFT SIDE FIRST. Continue armhole decreases BUT AT THE SAME TIME, ON NECK EDGE, dec. 1 st. every 3rd R 27 (29)x. After R 265 (275), SHAPE SHOULDER: Bind off 8 sts. 4x (9 sts. 3x, 7 sts. 1x). Bring the sts. on RIGHT TO WP, Row Counter 190 (196) and complete same as left side, omitting Flower and reversing all shapings.

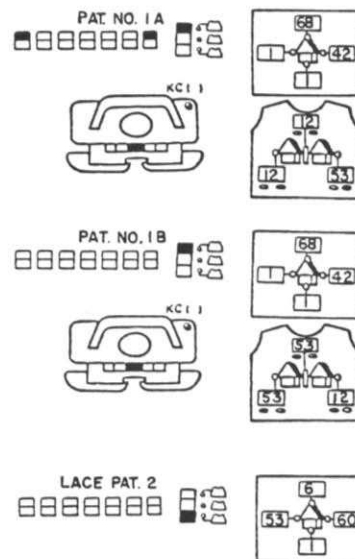
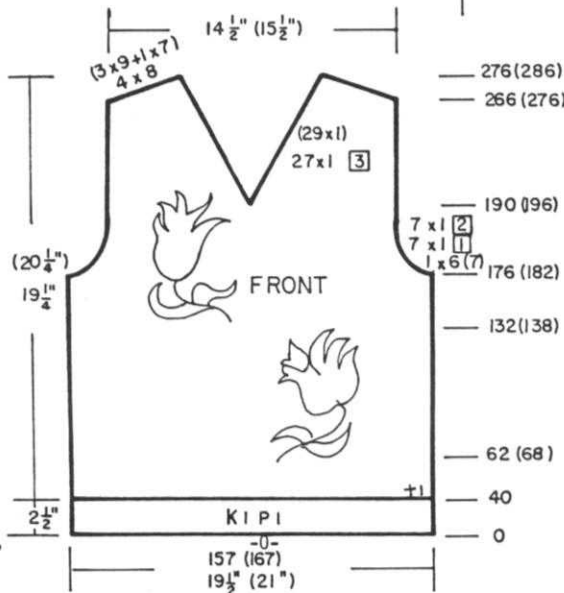

SLEEVES: Tension 5.1

With W.Y. cast on 100 (108) sts. Knit several rows ending with 1 row Ravel Cord to the right. Change to Col. 1, Counter 0. Knit 2 rows. Begin LACE PAT. ON EACH SIDE, inc. 1 st. every 20 rows 7x. After R 150 (154), SHAPE CAP: FOLLOW CHART for decreases in your size and please NOTE DECREASES ARE NOT THE SAME FOR BOTH SIDES After R 220 (228), bind off remaining sts.

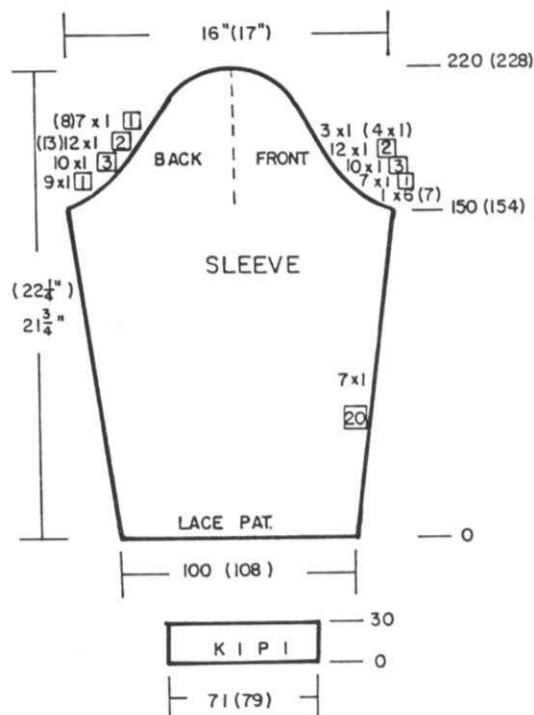

SLEEVE CUFFS:

K1, P1 Rib: Cast on 71 (79) sts. Knit 30 rows. Transfer Rib. sts. to MB. Hang the open sts. of sleeve onto these Hdl's., decreasing evenly across. Knit 1 loose row then crochet bind off.

SKIRT MAKE 3 PANELS

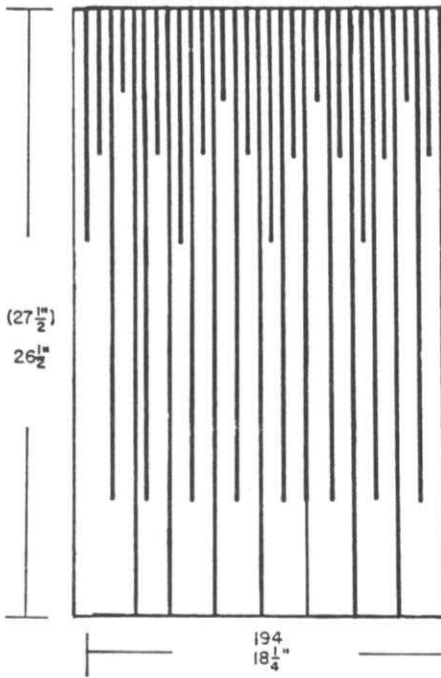

310 (320)

70 (80) R.

240

30 R

210

130 R

80

80 R

0

Skirt Band Make 2

142 (148)

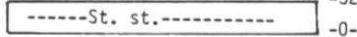

SKIRT BANDS: Make 2.

With color 1, CO as for a Hem 142 (148) sts. Knit St. st. to R 32. Hang first row knitted onto these Ndl's. to form hem. Knit 1 row across all sts. JOIN SKIRT PANELS TOGETHER FIRST, then pick up 1/2 of skirt waist onto waistband, decreasing evenly across. Bind off loosely. REPEAT for 2nd band.

SKIRT: MAKE 3 PANELS USING THE GARTER CARRIAGE.

With Col. 1 and T 5, cast on 194 sts. Set SKIRT PROGRAM NO. 1, G Carriage Counter to 80. Knit 80 rows. Set SKIRT PROGRAM NO. 2, G Carriage Counter 130. Knit 130 rows. Set SKIRT PROGRAM NO. 3, G Carriage Counter 30. Knit 30 rows. After R 240 (Reg. Counter). SET SKIRT PROGRAM NO. 4, G Carriage Counter 70. Knit 70 rows. (80 Rows) After R 310 (320) on regular Counter, remove onto W.Y. Make 2 more sections the same.

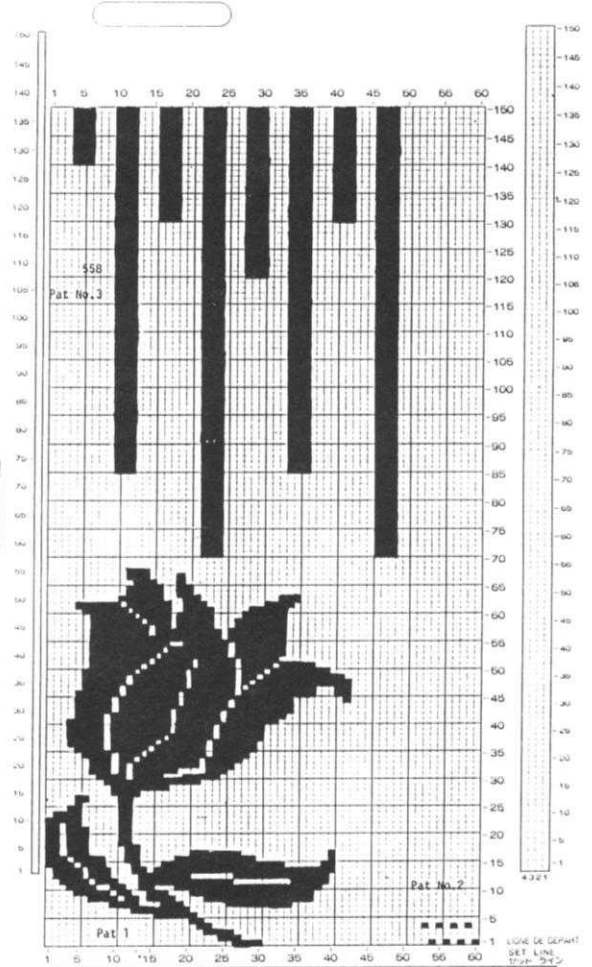
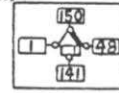
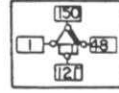
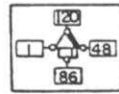
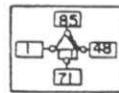

FINISHING:

See General Instructions.

INTARSIA CARRIAGE KA 2600

The new KA 2600 INTARSIA CARRIAGE is made only for the KH 260 Punch Card Bulky knitter. With it, you can knit large pictures, argyle designs or random blocks of different textures in as many colors as you wish without strands of yarn (floats) carried over the purl side of your knitting. When knitting Intarsia designs, the Intarsia Carriage replaces the main carriage of your knitter. It has a tension control dial to match the dial on your machine and it comes complete with a detailed instruction manual in English, Spanish, German, French and Italian.

PRICE: \$44.95 plus \$2.50 shipping...

Order from your local dealer or direct from: KNITKING, 1128 Crenshaw Blvd., L.A.CA 90019

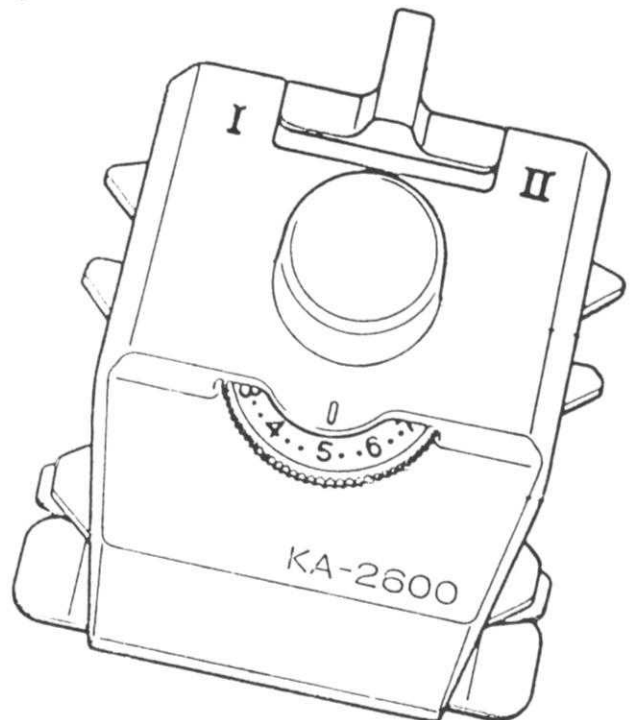



BACK:

Work the same as Front to R 372 (392). Bind off the center 42 (48) sts. With Ravel Cord, knit the sts. on the left back to 'A' position and complete same as Front. After R 380 (400), bind off. Continue same as front.

NECK BANDS: Make 2 Garter Stitch. T 5. With wrong side facing, pick up 42 (48) sts. along front neck. (Be sure to pick up the WHOLE bind off st). Knit 12 rows Garter Stitch. Bind off. REPEAT FOR BACK NECK EDGE.

SIDE NECK BANDS: Make 2 Garter Stitch. T 5. Bring 42 Ndl. to WP. Pick up sts. along side neck edge. Knit 12 rows Garter St. Bind off

BELT: Make 2. Garter St. T 5.

Bring 94 Ndl. to holding position and with garment yarn, CROCHET CAST ON BEHIND THE LATCHES. Push the Ndl. carefully into working position. Knit 12 rows Garter St. Bind off. Sew 2 short ends together. Fold other ends over to form point and slip stitch in place.

WOMENS GARTER STITCH DRESS

SIZES: 6/8 (10/12)
YARN: Icecream
AMOUNT: 2 lbs. 4 oz. 6/8
2 lbs. 8 oz. 10/12
TENSION: See Chart
GAUGE: 16 Sts 19 R=2" Tension 6

Make on any Standard Punch Card Machine with GARTER CARRIAGE.

For the Garter Stitch bands and lower edge of dress, use Punch Card 2B from original set of standard Cards. For Pat. 2, punch card.

NOTE: Please look at Chart so you understand that the figures closest to the Chart are settings for the G Carriage. The figures farther to the right are continuous rows counted by the regular Counter.

FRONT:

Select needle placement from Diagram. 'e' cast on 160 (172) sts. PROGRAM FOR GARTER STITCH. Set G.C. Counter to 10 Ten.6 Begin with G.C. on the RIGHT side. Press Green start on G.C. and knit 10 rows. G.C. will automatically stop. Change to Pattern 2. Set G.C. Counter to 48, regular Counter 0. DO NOT CHANGE REGULAR COUNTER FOR BALANCE OF DRESS. Follow Tension changes as shown on Chart. Pattern is repeated throughout entire dress. START G.C. and knit 48 rows. At Row 52, change Tension. Set G.C. to 52 and continue to FOLLOW CHART for balance of front. but AT THE SAME TIME, after R 230 (240) (regular Counter), mark EACH SIDE with W.Y. for waist. After R 308 (322), ON EACH SIDE bind off 26 sts for armhole. After R 338 (358) bind off the center 42 (48) sts. With a RAVEL CORD, knit the sts. on LEFT back to 'A' position, then complete the right side first. After R 380 (400), bind off. Carefully bring Ndl. on left back to WP and remove Ravel Cord. Turn Row Counter back to 338 (358) and complete left half.

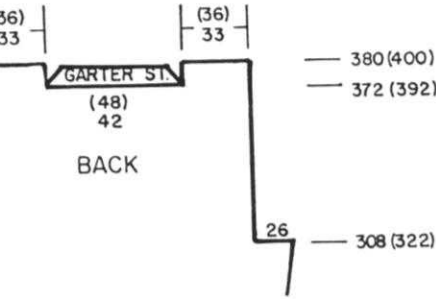

SLEEVES:

'e' cast on 104 (112) sts. Follow the Chart for Tension changes and after R 148 (162) remove on W.Y. Bring 88 (94) Ndl. to WP. Hang open sts. of sleeve onto these Ndl. decreasing evenly across. Knit 1 row over all Ndl. (with Regular Carriage if desired.) With T 5 and G.C. knit 10 rows Garter Stitch. Bind off.

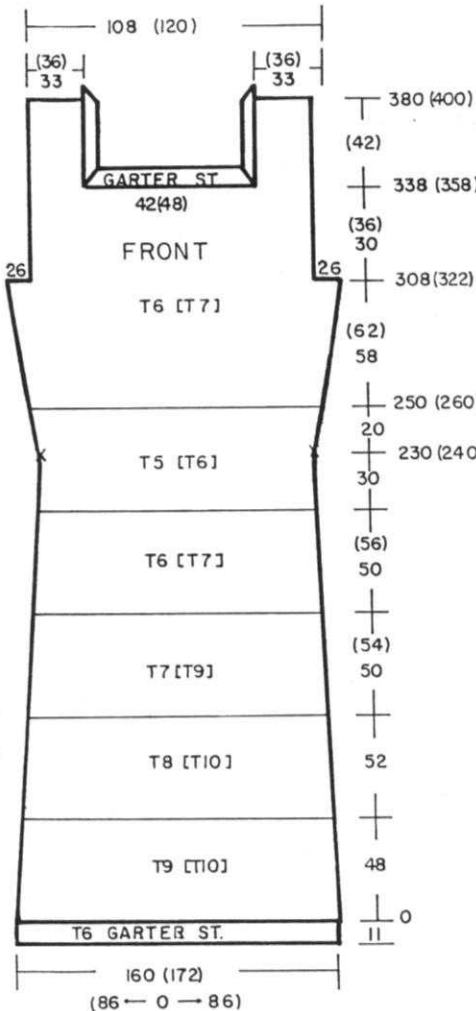
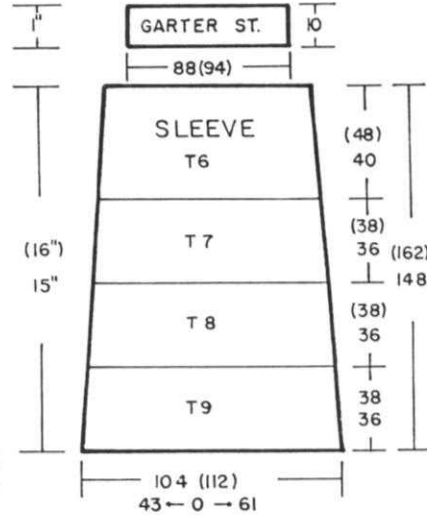

FINISHING:

See General Instructions. To finish Neckbands, Mitre each corner on the wrong side and sew with matching thread. Open the seam and press flat.

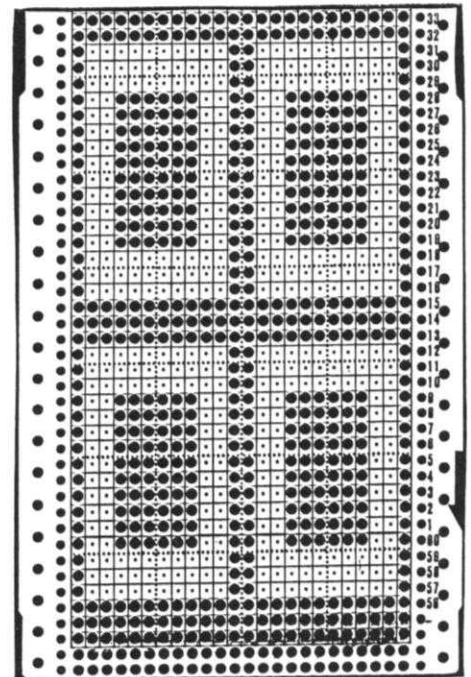

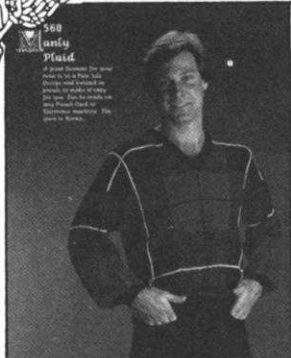

MENS SWEATER

SIZES: 38/40 (42/44)
 YARN: Roma
 AMOUNT:
 Col. 1 10 oz. 11 oz.
 Col. 2 10 oz. 11 oz.
 Col. 3 Very small amount

TENSION: St. st. 3.2 Rib 0.1/0 II
 GAUGE: 19 sts. 22.5 rows = 2" (5 cm)
 Make on any Standard or Electronic Machine. Fair Isle & Stock. stitch
 K1, P1 Ribbing. Punch Card.

BACK: Make 2 Side Panels
 With W.Y. cast on 65 (70) sts.
 After several rows end with 1 row Ravel Cord to the right.
 Counter 0, change to Col. 1
 Knit St. st. to Row 40 (42)
 Change to Col. 3. Knit 2 rows.
 Change to Col. 1 and continue in St. st. to Row 82 (86) setting Fair Isle Pattern before knitting last row.
 Knit to R 122 (128). Stop Fair Isle Pat. With Col 1, knit 2 rows St. st, setting Pat on 2nd row. Continue in Pattern changing colors as shown on Chart.
 AT THE SAME TIME, after R 138 (142) mark each side for setting in sleeves.
 After R 164 (172), cancel Pattern and with Col. 1, knit to R 202 (214). Change to Col. 3, knit 2 rows. Continue to follow Chart to Row 246 (258). Bind off or remove on W.Y.

BACK: Center Panel- Make 1
 With W.Y. cast on 66 (70) sts. same as for side Panels. After Ravel Cord row, change to Col. 1. Counter 0. Knit 2 rows, setting Pattern on second row same as before. Continue to follow Chart changing colors as shown.
 After R 246 (258), bind off or remove on W.Y.

FRONT: Make 2 Side Panels .
 Knit the same as the 2 back Panels.

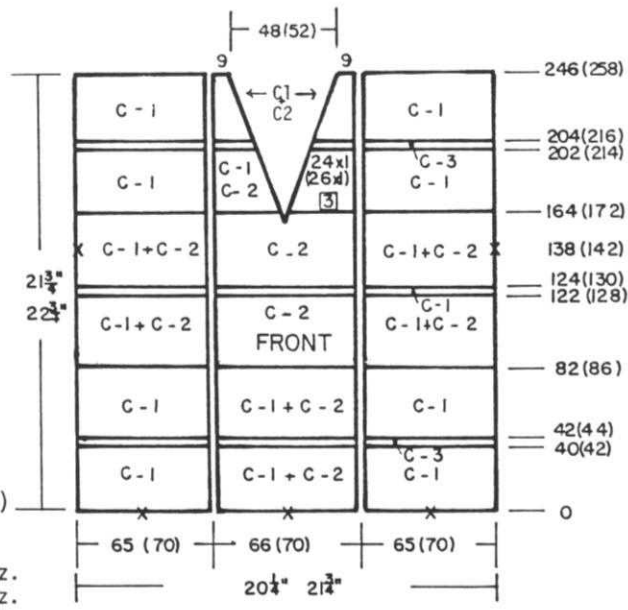

FRONT: Center Panel - Make 1
 Cast on same as center Panel for back. Follow the Chart in the same way and after R 164 (172) divide in the center for 'V' neck. Place sts. on left into HP (or knit them back to A position (NWP) with Ravel Cord. Complete the right side first.
 *ON NECK SIDE, decrease 1 st. every 3rd row 24 (26)x. Continuing in Fair Isle Pat. following Chart.. After R 246 (258) bind off remaining 9 sts.
 Bring the Ndl. on left to WP Turn Row Counter back to 164 (172) and complete the left half. Follow instructions from *.

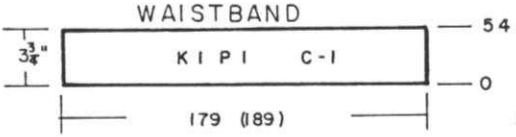

WAISTBAND: Make 2
 Join Panels of front and panels of back first.
 K1, P1 Rib.: With Col. 1, cast on 179 (189) sts. Knit 54 rows. Transfer Rib sts. to MB. Hang the open sts. of front onto these Ndl. Bind off. Repeat for Back.

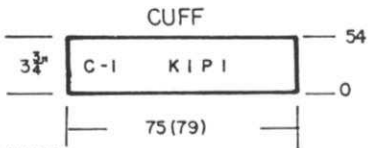
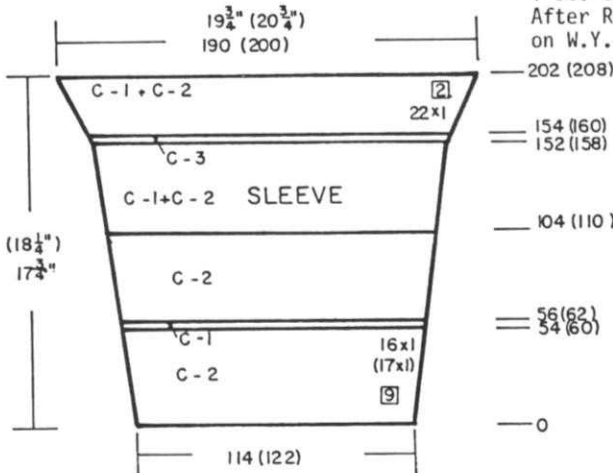

CUFFS:
 K1, P1 Rib: With Col. 1, cast on 75 (79) sts. Knit 54 rows. Transfer Rib sts. to MB. With wrong side facing, hang open sts. from lower edge of Sleeve onto these Ndl. decreasing evenly across. Bind off.

NECKBAND: Long Band
 K1, P1 Rib: Cast on 129 (135) sts. with Col. 1. ON THE RIGHT, decrease 1 st. EOR 8x, then Increase 1 st. EOR 8x.
 After Row 32, transfer Rib sts. to MB. Hang hem. With wrong side facing, pick up 79 (83) sts. along V and the remaining across back neck (SEW SHOULDER FIRST). Bind off.

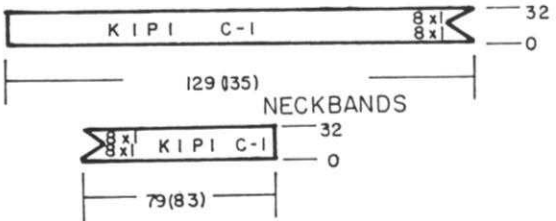

NECKBAND: Short Band
 K1, P1 Rib. With Col. 1, cast on 79 (83) sts. Work same as longer band but make the decreases and increases ON THE LEFT. After R 32, transfer Rib sts. to MB. With wrong side facing, pick up 79 (83) sts. along V then bind off.

SLEEVES:
 With W.Y. cast on 114 (122) sts. After several rows end with 1 row Ravel Cord to the right. Change to Col. 2 and continue St. st. ON EACH SIDE, increase 1 st. every 9th row 16 (17)x AND AT THE SAME TIME, FOLLOW THE CHART for the changes in Color and Pattern changes. After R 154 (160) ON EACH SIDE, inc. 1 st. every 2 rows 22x.
 After R 202 (208) bind off or remove on W.Y.

FINISHING:
 See General Instructions. To make the stripes down the center of Panels, use a latch tool or crochet hook and DOUBLE STRAND OF YARN and work a CHAIN ST. over two Rows using colors as shown (See Picture).



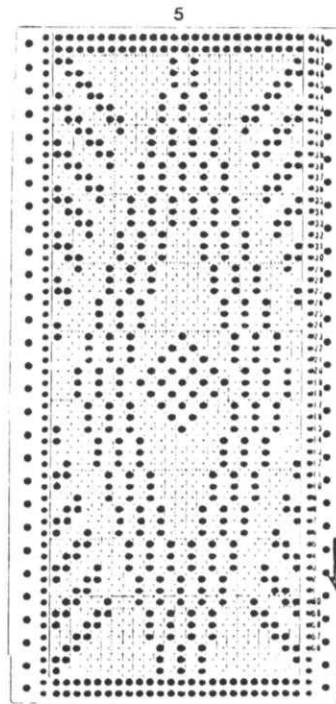
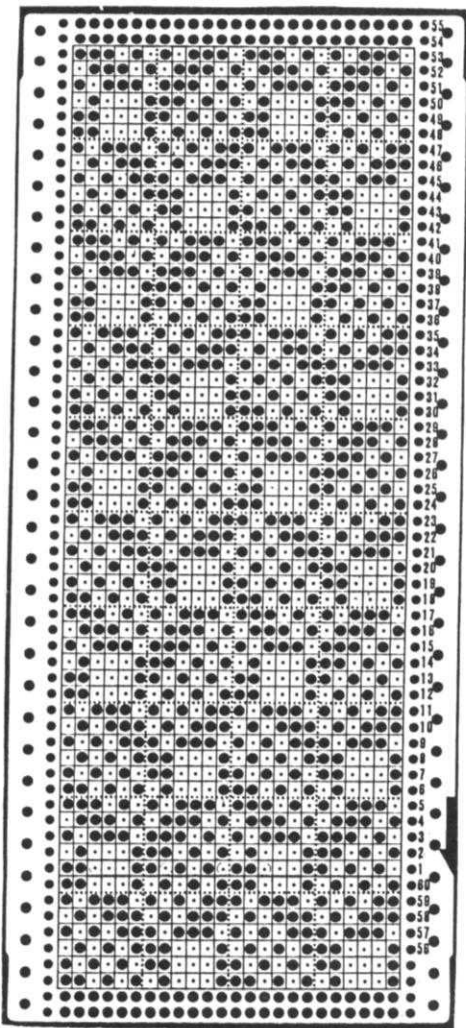

Pat.
525

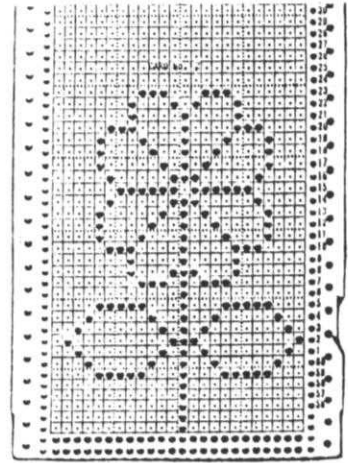

Pat.
526

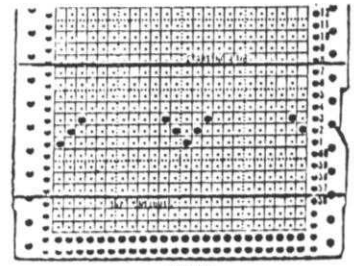

Pat.
526

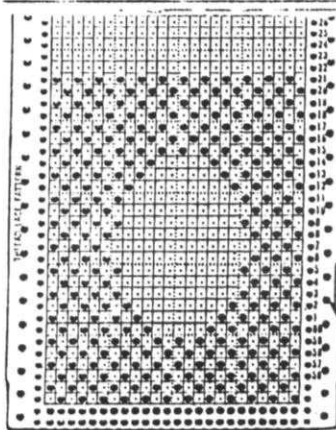

Pat.
522

We regret that the above Punch Cards were omitted from our last issue - Vol. 20 No. 3.

IT'S READY NOW!

KNITTING MAGAZINE BOUND VOLUME 20

- HARD BOARD COVER
- COMPLETE INSTRUCTIONS
- WILL HOLD ANOTHER COMPLETE VOLUME

Price: \$24.95
Shipping Costs - \$3.25





MENS STRIPED SWEATER

SIZES: 40/42 (44/46)

YARN: BULKY Venetia

AMOUNT:

- Col. 1 White = 14 oz. all sizes.
- Col. 2 Red = 10 oz.
- Col. 3 Yellow = 2 oz.
- Col. 4 Blue = 1 oz.

TENSION: St. st. 2 FNR 2/1 II

GAUGE: 10 sts. 13 rows = 2" (5 cm)

Make on any BULKY Machine with Ribber. St. st. with Color Stripes. Bands are Full Needle Ribbing (FNR).

SLEEVES:

With W.Y. cast on 64 (70) sts. After several rows end with 1 row Ravel Cord to the right. Change to Col. 1. Counter 0. Knit to R 22 (24) then begin following Color stripes 30 rows Red, 16 rows White, etc. BUT AT THE SAME TIME, ON EACH SIDE, inc. 1 st. every 6th row 17x. After R 104 (106), FOLLOW CHART FOR RAGLAN DECREASES (full fashion) and PLEASE NOTE THAT EACH SIDE HAS DIFFERENT SHAPINGS. After R170 (176) ON RIGHT SIDE, bind off or use Short Rows, 6 sts. 2x, 5 sts. 1x.

STRIPED PATTERN

COLOR	BACK ROWS	FRONT ROWS
WHITE	12 (16)	8 (12)
RED	8	8
WHITE	16	16
RED	2	2
YELLOW	4	4
RED	8	8
BLUE	8	8
RED	8	8
YELLOW	4	4
RED	2	2
WHITE	4	4
YELLOW	8	8
WHITE	16	16
RED	8	8
WHITE	16	16
RED	30	30
WHITE	6 (8)	6 (8) BE-

GINNING COLOR AFTER WAIST-BAND.

BACK:

FNR: With Col. 1, cast on 106 (114) sts. Knit to R 28. Transfer Rib sts. to MB. Continue in St. st. and begin stripe Pat. Start with 6 (8) rows Col. 1 then 30 rows RED, etc. following the color Chart UP. After R 118 (120) SHAPE RAGLAN: ON EACH SIDE, using FULL FASHION METHOD, decrease 1 st. 1x, 2 sts. EOR 2 (3)x, 2 sts. every 3rd row 2, 2 sts. every 4th row 14x and 2 sts. EOR 1 (2)x. After R 188 (194) bind off or remove on W.Y.

FRONT:

Knit the same as Back to R 118 (120). SHAPE RAGLAN: Full Fashion Method. 2 sts. 1x, 2 sts. EOR 3 (4)x, 2 sts. every 3rd row 10x, 2 sts. every 6th row 4x., 2 sts. 2x (1 st. 1x) BUT AT THE SAME TIME, after R 134 (140), divide in the Center. Place sts. on left into HP (or knit them back to NWP (A) position with Ravel Cord and complete the right side first. *ON NECK SIDE, dec. 1 st. every 3rd row 7 (8)x, 1 st. every 4th row 6x. Be sure to continue raglan shaping. All decreasing is completed at R 184 (190). Bring the Ndl. on left to WP, Turn Row Counter back to 134 (140) and complete left half. Follow instructions from *.

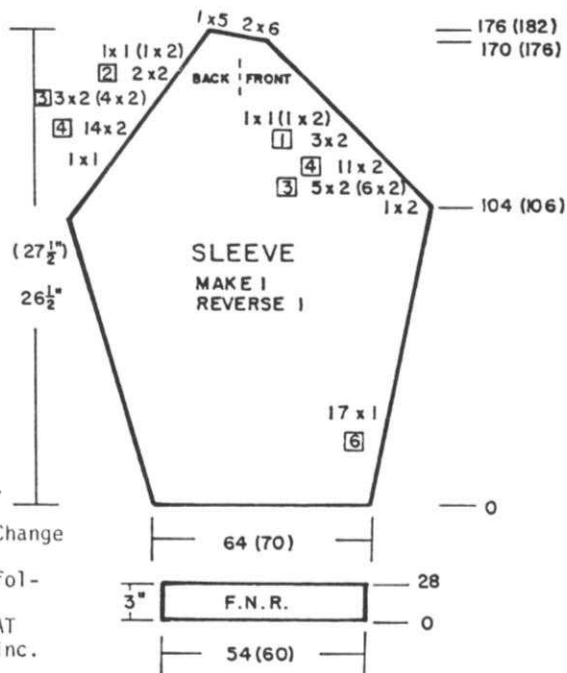

CUFF:

FNR: With Col. 1, cast on 54 (60) sts. After Row 28, transfer Rib sts. to MB. With wrong side facing, hang the open sts. of sleeve edge onto these Ndl. decreasing evenly across. Knit 1 row. Bind off.

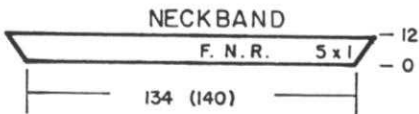
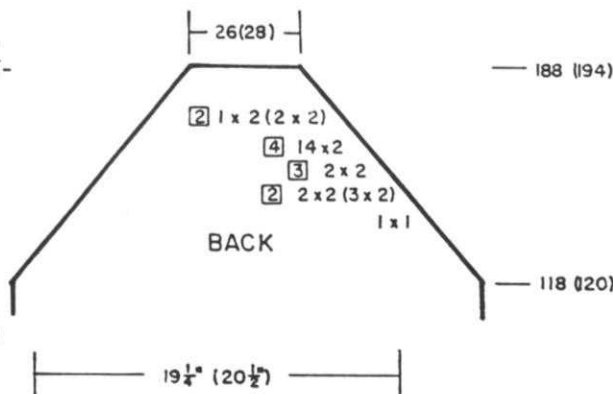

NECKBAND: Close Raglan Seams first.

FNR: T 1.2/1 II. With Col. 1, cast on 134 (140) sts. ON EACH SIDE, increase 1 st. EOR 5x. After R 12, transfer Rib sts. to MB. Knit 1 row over the doubled sts. then remove on W.Y. Sew or weave the 2 ends of band together, then weave to Neckline with V at front.

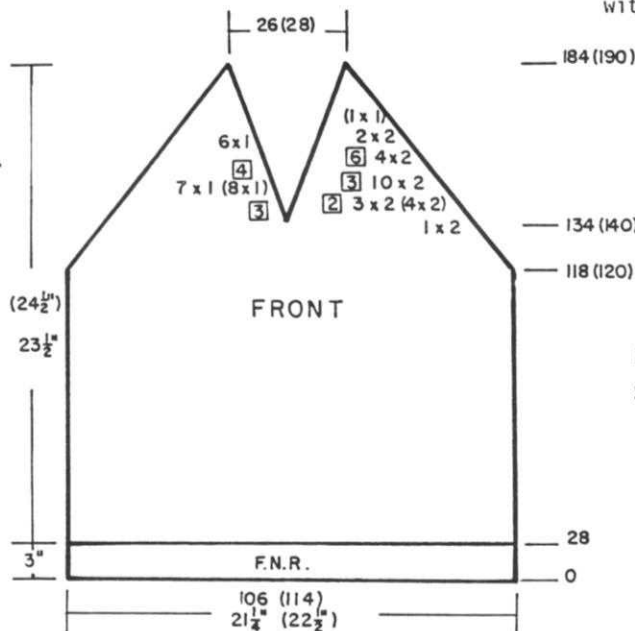

FINISHING:

See General Instructions.

PRACTICAL KNITTING HINTS

DOUBLE BUTTONHOLES IN A STOCKINETTE STITCH BAND

When you are making a double band in Stockinette stitch and you need to make Buttonholes spaced across the band, there is a way to completely finish the buttonholes as you are knitting the band.

For our SAMPLE, cast on 60 sts. We will make 3 buttonholes and the band is 20 rows completed. Cast on with waste yarn (ordinarily you would pick up sts. along the edge where you want a band). After knitting about 1" with waste yarn, change to main or garment yarn and 'e' cast on over all sts. behind the latches. Counting from the left edge, skip 5 sts. Mark the next 5 needles on the needlebed with a pencil. *Skip 15 sts. and mark the next 5 needles. REPEAT FROM * 1x more. You have marked the needlebed for 3 buttonholes in our sample. With garment yarn, knit 5 rows. With a long strand of waste yarn (same weight), knit the MARKED STS. BY HAND LOOSELY then bring them to holding position (so they will knit on the next row). With garment yarn, knit 10 rows. Bring the marked needles to selecting position. Pick up the TOP ROW of the buttonhole sts. held on waste yarn and hang them onto marked needles. With garment yarn, knit these sts. by hand (use separate strand for each buttonhole) loosely. Bring the needles to HP again and with latch tool bind off the 5 sts. pulling 2nd st. through first, 3rd through 2nd, etc. Hang the last loop on adjacent needle. Pick up the sts. from LOWER ROW held on waste yarn and hang them onto empty needles. Bring these Ndl's. to HP so they will knit. Knit 5 rows. PICK UP THE 'e' CAST ON ROW to form hem. Bind off.

CASING FOR PEPLUM - PATTERN 554

This is just a reminder for CARRIAGE SETTINGS on MAIN BED and RIBBER.
When knitting on BOTH BEDS, PR BUTTONS on RIBBER are DOWN.
When knitting on MAIN BED ONLY, PR BUTTONS on RIBBER must be UP.
When knitting on RIBBER ONLY, BOTH PART BUTTONS on MAIN BED must be PUSHED IN.

YARN KITS FOR GARMENTS IN THIS ISSUE

American Yarn Spinners are truly expert in the production of Cone Yarns generally used for the manufacture of mass produced knitted garments. Quality hand knitting yarns in balls and skeins have traditionally been imported mainly from Europe and Australia. A demand on the part of Manufacturers of high priced garments such as St. John, Adolfo, Miss Jo Ann, Jessica Knits and many more resulted in the production of higher priced, quality dress yarns such as Wool/Rayon mixtures sold under various name brand names (ours is Venetia). Roma is another cone yarn that has gained tremendously in popularity and we recently introduced another modern yarn under the GLACE name.

The big reduction in the value of the American dollar against other currencies over the past year, has caused a substantial increase in the price of imported yarns. In many cases prices have doubled. This fact coupled with lengthy delivery problems and the increasing need for cone yarns to satisfy the demand of the rapidly growing numbers of home knitting machine owners, has encouraged several U.S. spinning companies to develop fancy yarns and supply them on cones at very competitive prices.

KNITTING intends to phase out the imported yarns as shown in our current Catalog, so if you need any Kits from this or earlier issues, please place your orders right away and avoid disappointment. We will introduce new cone yarns on a continuing basis and produce single sample cards of each yarn and available colors at the time of introduction. Cards for Venetia, Roma and Glace are available for \$1.00 each, postpaid.

No. 541 - Yarn:	Venetia		
SIZES:	10/12	(14/16)	
Price:	\$19.82	\$19.82	
Shipping:	1.85	1.85	
No. 542 - Yarn:	Fine Venetia & Fine Mohair		
SIZES:	8/10	(12/14)	[16/18]
Price:	\$34.68	\$34.68	\$34.68
Shipping:	1.85	1.85	1.85
No. 543 - Yarn:	Regia		
SIZES:	8/10	(12/14)	
Price:	\$28.60	\$30.80	
Shipping:	1.85	1.85	
No. 544 - Yarn:	Venetia		
SIZES:	6/8	10/12	
Price:	\$45.54	\$49.50	
Shipping:	3.50	3.50	
No. 545 - Yarn:	Venetia		
SIZES:	8/10	(12/14)	[16]
Price:	\$31.68	\$31.68	\$37.62
Shipping:	2.50	2.50	2.50
No. 546 - Yarn:	Roma		
SIZES:	6/8	(10/12)	[14/16]
Price:	\$22.08	\$22.08	\$22.08
Shipping:	3.50	3.50	3.50
No. 547 - Yarn:	Venetia & Roma		
SIZES:	6/8	(10/12)	[14/16]
Price:	\$42.72	\$42.72	\$42.72
Shipping:	3.50	3.50	3.50
No. 548 - Yarn:	Venetia		
SIZES:	8/10	(12/14)	
Price:	\$24.75	\$27.72	
Shipping:	3.50	3.50	
No. 549 - Yarn:	Marisa 100% Cotton		
SIZES:	6/8	(10/12)	[14/16]
Price:	\$88.00	\$88.00	\$88.00
Shipping:	4.00	4.00	4.00
No. 550 - Yarn:	Venetia		
SIZES:	8/10	(14/16)	
Price:	\$31.68	\$31.68	
Shipping:	3.50	3.50	
No. 551 - Yarn:	Venetia		
SIZES:	10/12	(14/16)	
Price:	\$31.68	\$31.68	
Shipping:	3.50	3.50	
No. 552 - Yarn:	Venetia		
SIZES:	6/8	(10/12)	
Price:	\$31.68	\$31.68	
Shipping:	3.50	3.50	
No. 553 - Yarn:	Cordella & Alpaca		
SIZES:	Medium	(Large)	
Price:	\$46.96	\$46.96	
Shipping:	3.50	3.50	
No. 554 - Yarn:	Venetia		
SIZES:	10/12	(14/16)	
Price:	\$39.60	\$39.60	
Shipping:	3.50	3.50	
No. 555 - Yarn:	Venetia		
SIZES:	6/8	(10/12)	[14/16]
Price:	\$55.44	\$55.44	\$55.44
Shipping:	4.00	4.00	4.00
No. 556 - Yarn:	Amore		
Womens	38/40	(44/46)	
Price:	\$26.29	\$28.68	
Shipping:	2.50	2.50	
No. 556 - Yarn:	Amore		
Childs	3	(4)	**
Price:	\$ 7.17	\$ 7.17	
Shipping:	1.85	1.85	
No. 557 - Yarn:	Capriccio & Venetia		
SIZES:	8/10	(12/14)	
Price:	\$76.67	\$76.67	
Shipping:	4.00	4.00	

- | | | |
|-----------------|---------------------------------|---------|
| No. 558 - Yarn: | Venetia, Isabella, Angora | |
| SIZES: | 10/12 | 14/16 |
| Price: | \$38.18 | \$38.18 |
| Shipping: | 3.00 | 3.00 |
| No. 559 - Yarn: | Ice Cream 62% Cotton, 38% Rayon | |
| SIZES: | 6/8 | (10/12) |
| Price: | \$70.20 | \$78.00 |
| Shipping: | 4.50 | 4.50 |
| No. 560 - Yarn: | Roma | |
| SIZES: | 38/40 | (42/44) |
| Price: | \$15.18 | \$16.56 |
| Shipping: | 2.50 | 2.50 |
| No. 561 - Yarn: | Bulky Venetia | |
| SIZES: | 40/42 | (44/46) |
| Price: | \$26.73 | \$26.73 |
| Shipping: | 3.50 | 3.50 |

** - The Kit for the Child's size allows only for the Main Color yarn. If you knit the Womens size, you will have enough yarn (6 additional colors) to use for the Child's sweater. If you are making the child's garment only, please add the additional 6 balls. The kit will then cost \$21.51.



SALE OF PRE-OWNED COMPUKNIT II (KH 910) KNITTING MACHINES

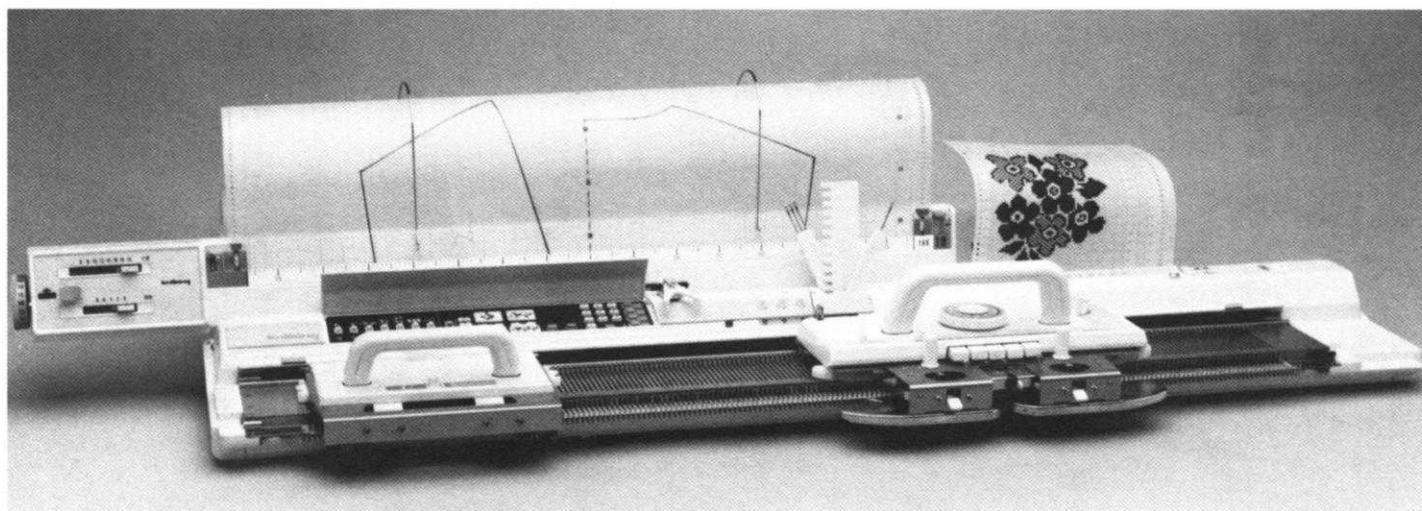

We have taken a quantity of these fine knitting machines in trade.. We re-build them and check them thoroughly to see that they are in **excellent working condition....** The KH 910 accepts the **KG 88** and the **KG 88-II Garter Carriages... and Ribbing Attachments** from the KR 830 through KR 900. All re-built machines are guaranteed for 90 days. The retail price of the KH 910 is \$999.95.... **Our price for a re-built KH 910 is ONLY \$499.95..** VISA or MASTERCARD accepted.

Order direct from KNITTING, 1128 Crenshaw Boulevard, Los Angeles, CA 90019

The Knitleader is not included in the price.

KNITKING introduces

The Twister

A two-way Winder.

Twist your way to multi-color garments... Create your own original yarns by twisting your own selection of colors and textures. It will also wind a single strand of yarn into a ball.



with Twister

without Twister

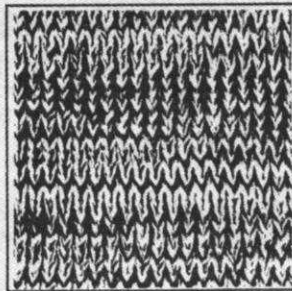
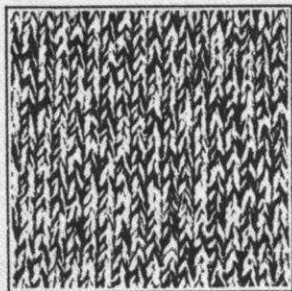

PRICE: \$29.95 -California residents add
Sales Tax.
SHIPPING costs—\$2.50

Order direct from your dealer or from:
KNITKING, 1128 Crenshaw Blvd., Los Angeles, Calif. 90019

knitking

KNITTING COMPUTER

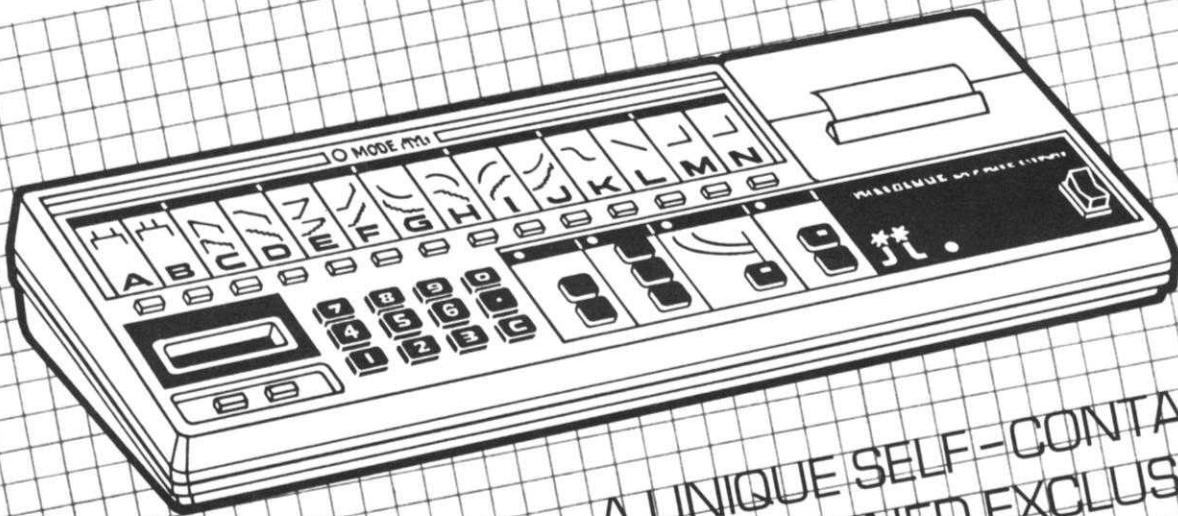

A UNIQUE SELF-CONTAINED
COMPUTER DESIGNED EXCLUSIVELY
FOR HAND AND MACHINE KNITTERS.

Every shape of garment sections, necklines, armholes, etc., is represented by a 'MODE' button. Push a Mode Button, program in your Stitch and Row Gauge, follow it with the Width and Length of the garment section, then watch the printer print out complete knitting instructions.

The Computing of knitting patterns can be done with standard computers plus expensive software, and you can easily spend thousands of dollars to obtain the same results as produced by the KNITKING Knitting Computer at a fraction of the price.

The KNITKING Knitting Computer operates with built in re-chargeable Nickel Cadmium Batteries. A charger is standard equipment as is a detailed Instruction Manual and some spare rolls of print out tape.

Price: \$499.00 (California residents add Sales Tax)
Order from your local dealer or direct from

**KNITKING — 1128 Crenshaw Blvd.,
Los Angeles, CA 90019**

Essentials...

Order from your local Dealer or direct from
KNITKING—1128 Crenshaw Blvd.,
 Los Angeles, California 90019

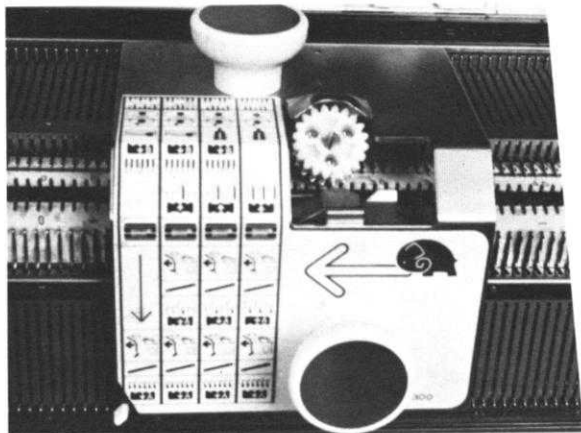

For fast and accurate transfer of stitches from Ribber to Knitter, the Automatic Transfer Carriage is ESSENTIAL.

Model 8300 is for Ribbers KR 900, KR 880, KR 850 and KR 830 and machine Models KR 830 through KH 910.

The PM 10 Automatic Punch Card puncher is essential for speedy punching of all your punch card designs. It's O.K. for all KNITKING, Singer, Studio and Toyota punch card machines except the Singer/Studio F-370 machine which uses the PM 70 Automatic Puncher.

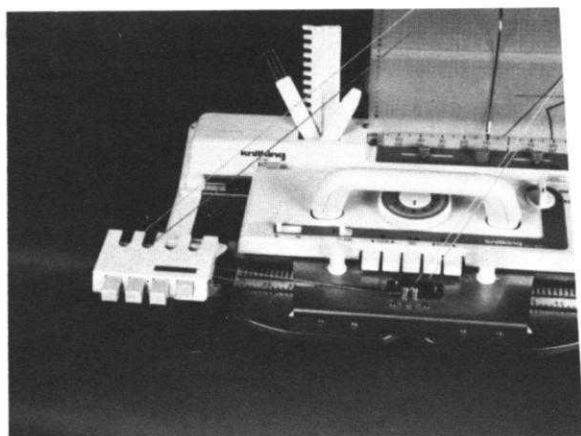
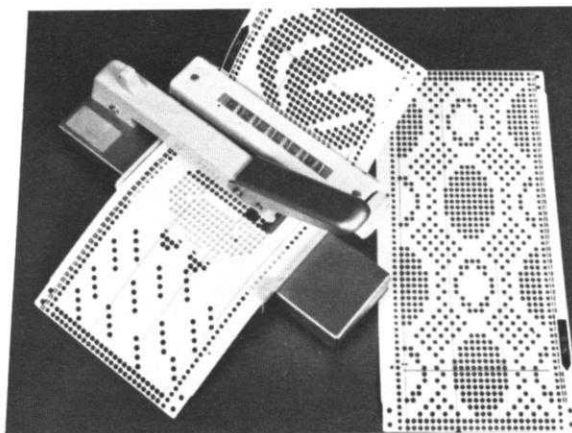

The KHC 820 Color Changer is essential for automatic changing of colors when knitting on KNITKING machine Models KH 820 through KH 910.

The KRC 830 Color Changer is essential for automatic color changing and the knitting of four color designs when using a Knitter and Ribber combination. It operates on Models KH 820 through KH 910 with Ribbing Attachment.

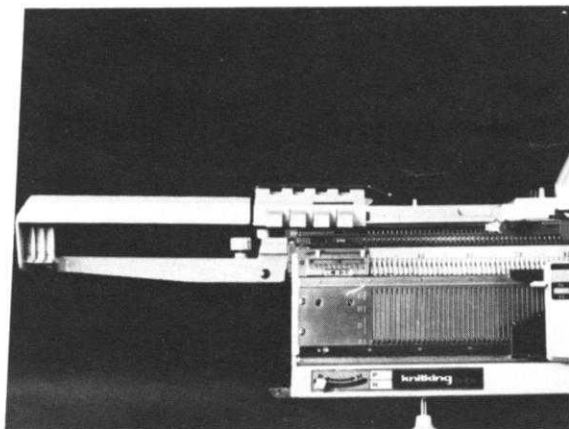



556

Special

Moments

Mother and Daughter look alike... Each beautiful Cardigan is Stockinette stitch with Intarsia Designs that are fun to knit. Practice on a sample first and you will be an expert. Amore is the yarn.



542 Sunshine Bright

A colorful slim Skirt in a Tuck Stitch Pattern is topped with a Stockinette Stitch Dolman sleeve Pullover. Turn the Sweater around and it has a deep 'V' neckline. Venetia is the yarn.



547 *S*parkling

Attend a special party wearing this lovely Dress with spangles on the bodice. The delicate lace peeping through the slit on front is actually a separate Skirt. We've used Venetia for the Dress, Roma for the Underskirt.



543 Tunic Time

The ever popular Tunic to wear with Pants or Skirt. Cables on the diagonal accent the clever 'V' neck shaping. We knitted our Tunic with Regia.



551

Seasonless

Lovely to look at and beautifully shaped, the slim lines on this Dress will flatter any figure. A cowl neckline and swinging flare at lower edge are fashion news. The yarn is Venetia. Sizes are Medium and Large.



561 Spaced Out

A Mens striped Pullover is knitted in Stockinette stitch using four colors and the color stripes are most unusual with different spacings. It is knitted on the Bulky with Bulky Venetia.



560 Manly Plaid

A great Sweater for your man is in a Fair Isle Design and knitted in panels to make it easy for you. Can be made on any Punch Card or Electronic machine. The yarn is Roma.

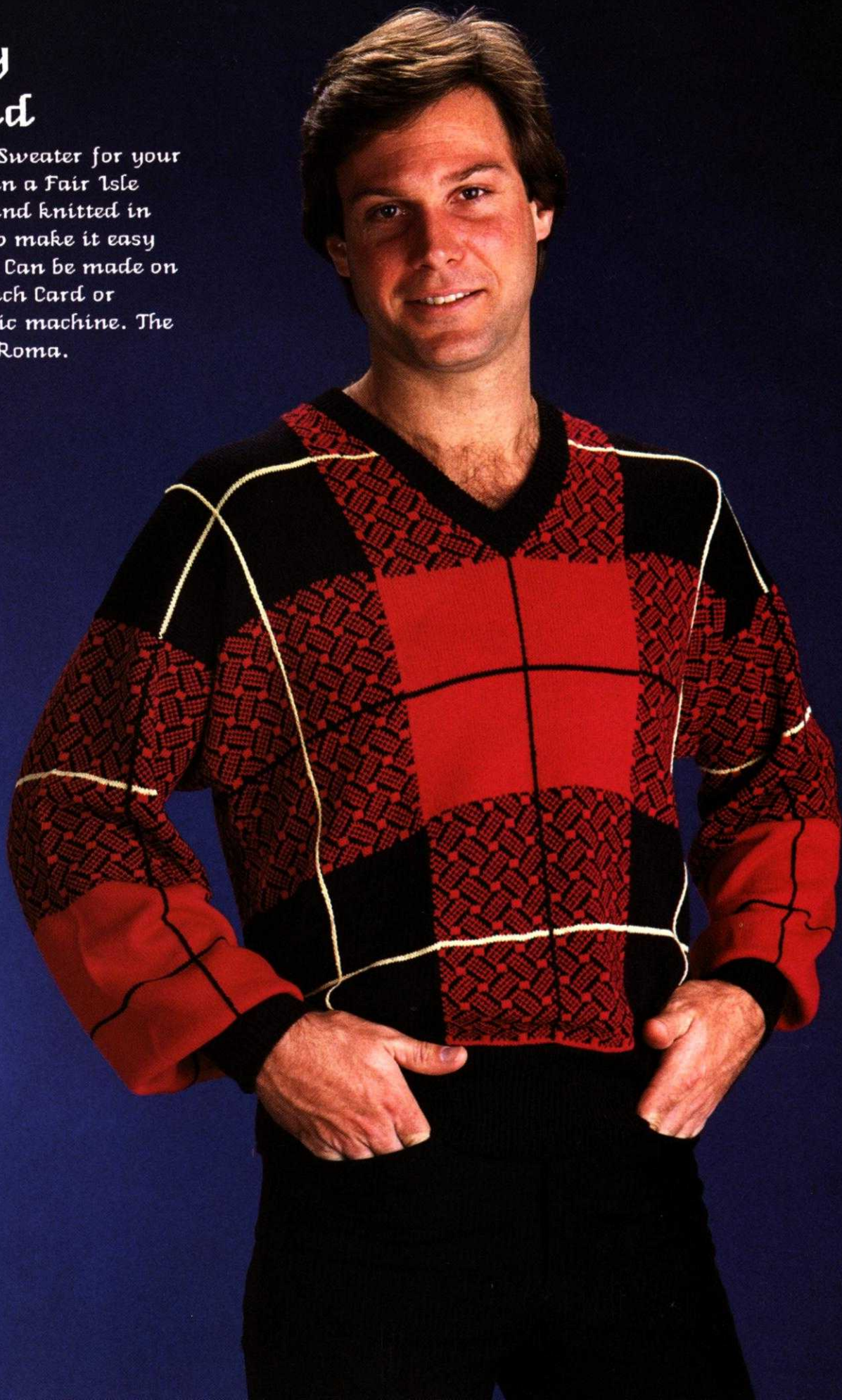

553



ariety

Everyone can use a big, soft colorful Cardigan. It's in English Rib with wide color stripes and large pockets. Knit it with Alpacana.



JUMBO GENIE

"the magic knitter"

JUMBO GENIE IS A
BULKY BEST BUY ...check
 its price and versatility
 against other brand
 bulky knitters.

It's a full size, 120 plated steel needles (8mm spacing) knitter that is just perfect for knitting 4 ply worsted weight yarn. Its range is from sport weight to jumbo yarn...Mohair, Angora, Nubby, Boucle, etc., etc....it knits them all.

The JUMBO GENIE has an all hardened steel (not plastic) needle bed for continuous smooth operation. Twin overhead adjustable yarn feeders and easily adjusted tension control for different weights of yarn.

The JUMBO GENIE has Intarsia and Tuck Knitting Controls built into the carriage. You pay extra for Intarsia knitting on some other machines. A row counter, kit of tools and instruction manual is standard with every machine and the JUMBO GENIE knitter weighs 20 lbs.

The JUMBO GENIE Ribbing Attachment converts the JUMBO GENIE knitter into a Double Bed machine with a total of 240 needles...you can actually knit rib design garments with dress yarns using all of the needles and you can knit zig zag rib designs with the built in racking device.
 After knitting ribbing for a garment, the ribber drops down and allows you to continue knitting on the main machine.



KNITTING Discount price for S-120 Knitter \$219.95
 KNITTING Discount price for R-120 Ribber 219.95
 Combination Price \$439.90

Order from your local Dealer or direct from

KNITKING
 1128 Crenshaw Blvd.
 Los Angeles, CA 90019
 (213) 938-2077



VISA and MASTERCARD accepted

FOR UNLIMITED VERSATILITY

The Sensational COMPUKNIT III



COMPUKNIT III with Lace Carriage and regular Knitting Carriage. Both carriages are standard with the purchase of a COMPUKNIT III. The Lace Carriage knits true Transfer Lace. It automatically knits beautiful yarn-over designs in any combination up to the full 200 needle width of the knitter. It also knits Fine Lace. The Computer permits isolation of Lace designs anywhere you wish in a garment.

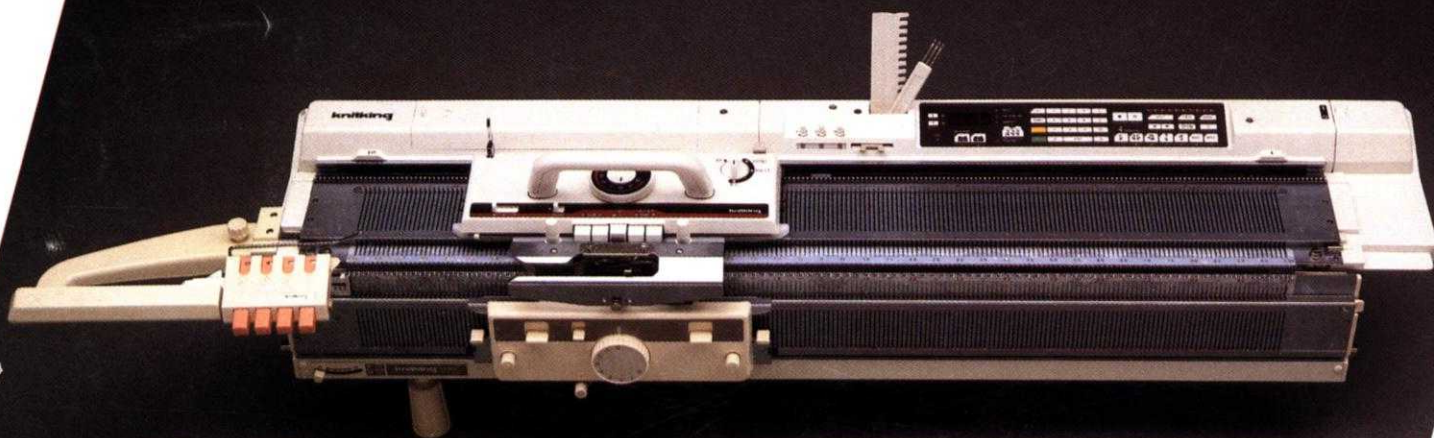

The COMPUKNIT III is illustrated with the KR 900 Ribbing Attachment and the KRC 830 Color Changer (both optional accessories). The Ribbing Attachment knits any combination of knit and purl ribs, racking designs, cable stitches, tubular knitting, etc. Add the KRC 830 Automatic Color Changer and you can knit up to four colors in one row in double knit jacquard. You can also introduce yarns of various textures into a garment. The KHC 820 Color Changer (not shown) operates on the basic machine for the knitting of multi-color designs in Stockinette Stitch.

Order from your local Dealer or direct from **KNITTING CORPORATION**, 1128 Crenshaw Blvd., Los Angeles, California 90019. Tel: 213-938-2077.