

VOL 20 # 2

Norma



knitking
magazine



FIT FOR ROYALTY!
GRAND NEW
FASHIONS
FOR YOU AND
YOUR COURT.





515

ELITE

Delicate Lace combines with Stockinette stitch and Stripes for a lovely Dress. We used Venetia and our newest yarn called Fantasia and it can be knitted on any standard machine. Pearl Buttons trim the front bodice. Sizes 6 to 16.





504

REMINISCENT

of a trip to a Wild Animal Park, our striking Design on this Pullover will catch every eye. It is knitted sideways on any standard machine. Wear it with a plain matching skirt. Beatrice is the yarn and the sizes are 6 to 16.



TABLE OF CONTENTS

VOLUME 20 NO. 2

TABLE OF CONTENTS	PAGE NO.
501—Women's Pullover	13
502—Women's Pullover	14
503—Women's Siesta Tunic	15
504—Women's Top & Skirt	15
505—Women's Two-Piece Dress	17
506—Women's Cardigan	19
507—Women's Feather & Fan Pullover	20
508—Ruana	22
509—Women's Pullover	22
510—Women's Two-Piece Dress	24
511—Men's Zippered Jacket	25
512—Men's Ribbed Pullover	27
513—Women's Vest & Skirt	28
514—Women's Dress	29
515—Women's Dress	31
516—Women's Three-Piece Ensemble	33
517—Women's Pullover	35
518—Women's Aztec Dress	37
519—Women's Two-Piece Dress	39
520—Women's Bulky Jacket	41
KNITKING NEWS	42

knitking

magazine

EDITORIAL

Everybody has some ability to be creative and when you put creativity to work with a knitting machine, you can produce some really unique outfits.

The United States population is a mixture of races from all over the world and at KNITKING we truly have our own League of Nations.... In addition to native born Americans with European and African ancestry, we have Chinese, Japanese, Mexican, Salvadoran, Jamaican, Swiss, Hawaiian, a teacher born in Romania who speaks six languages and your Editor and his Wife who are British. With all of this ethnic talent available, we have decided to produce a garment from time to time using some historic emblem or design peculiar to an ethnic group. We started by asking a designer in our magazine department who was born in Mexico to produce a dress for us that we could call Aztec. Her husband had several illustrated books handed down from his family in Mexico and from them she selected the Motifs shown on our Cover garment. The separate Yoke and decorative front Panel drops over the head on top of a basic garment in the manner illustrated in very old Aztec books. We think it is a unique garment, we think it aptly demonstrates what creativity and a knitting machine can produce.

KNITKING MAGAZINE ART WORK —

We receive many compliments regarding the Art work, the Photography and the layout of KNITKING MAGAZINE and we are sure you can appreciate the amount of planning and work that goes into every issue even after all the garments are designed and knitted. When we first introduced KNITKING MAGAZINE in 1964, the name of our artist and layout man was Tony Salari. Tony was well known in the printing business in Los Angeles and several of the better printers often used his talents. He was responsible for several years of work on KNITKING MAGAZINE; he worked out of his own Studio and made frequent trips to and from our premises. Tony had two young and cute daughters and he would sometimes bring one of them with him to our office. One day he announced that he was past retirement age and would be closing his studio. It was a sad day for KNITKING MAGAZINE. Tony had become a member of the KNITKING family and we understood each other well.

For two to three years after his retirement we switched Art Directors several times, then on one occasion we couldn't find the right person to work with us and in desperation we called Tony and asked him to help us out with one issue. He refused but said, "Why don't you ask my daughter, Rebecca—she has her own Studio and is a better artist than I am."

Rebecca Salari-Taylor, one of the cute youngsters Tony brought with him years ago, is now married to an artist. Between them they have built a reputation for their artistic talent and layout skills and it is Rebecca who is responsible for the excellent art work and layout designs you have seen for the past three years and hopefully will see for many years to come.

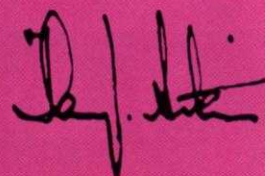

COVER

AZTEC QUEEN

And you certainly will look queenly wearing this beauty. It has a separate Yoke trimmed with long fringe and beads. You must use the KR 900 Ribber and 4-Color Changer to knit the multi-color Fair Isle Design to prevent floats on the back. We knitted it with Venetia plus Isabella for the sparkle. Sizes 10 to 16.



COLOR CODED

You will need a ribber to knit this special Vest with 4 colors in one row. No floats are on the back of the knitting and it can be made on any machine with Ribbing Attachment and 4 Color Changer. Venetia is the yarn and sizes are from 10 to 18.





514

DREAMY

For a special Party or a Prom, this feminine Dress has lace tiers to form the skirt section and the eyelets continue throughout. The Cape Collar with Lace Design covers the shoulders. Tuck a flower or fruit at the hip and neckline. Venetia yarn. Sizes 8 to 14.



510

DRAMATIC

Combine Stockinette stitch and Lace Patterning for a lovely two-piece Dress to wear anytime, anyplace. Make it on any machine using 2 colors of Venetia. The lower part of skirt is knitted sideways on the machine. Sizes 6 to 16.





517

DISTINCTIVE

An outstanding Pullover is knitted sideways on the machine with short row patterning. Knit it on any standard machine. Regia and Show yarn. In sizes 6 to 16.





507

SPECTACULAR

Knit this gorgeous Pullover sideways on a machine with a Garter Carriage. Change to the standard Carriage when knitting the stockinette stitch sections and make it with Cordella, Isabella and Angora in sizes 6 to 16.





ALLURING

A two-piece Dress with an elegant Lace Design that is isolated on the front and the three quarter length sleeves. It's flattering to all figures and you can wear it anytime and anyplace. Knit it in sizes 6 to 16 with Venetia.





516

ENSEMBLE

Three pieces—Pullover and
Pants are Stockinette stitch
with the Vest in an
elongated Tuck Design. The
stripes are formed with a
special technique using four
colors and we tell you how.
Venetia and Viola. Sizes 10
to 16.





509

CLASSIC CABLES

Cables are easy and fun to make on any bulky machine. We used bulky Venetia for this attractive Pullover. The bands are K1, P1 Ribbing. A large range of sizes to fit almost everyone. 6 to 16.

GENERAL INSTRUCTIONS



THE PRINTED INSTRUCTIONS

Follow the printed instructions or use them in combination with the Charts. Where there is any question in the instructions, you have the Charts to show you how the section will look.

Be sure to READ AHEAD so that you KNOW what to do for the size you are knitting. In the shapings, where the number of stitches are the same but the number of times different, you might find shapings like this...3 sts. 1 x (2x) [3x]—so that for the first size you will bind off 3 sts. 1x, 2nd size 3 sts. 2x, 3rd size 3 sts. 3x. Sometimes the ROWS will be different for each size—so you must watch out for different row numbers.

Shoulder and neck shapings for the back section of a garment usually are shaped at the same time—so ALWAYS WATCH for the words AT THE SAME TIME.

HOLDING STITCHES ON THE LEFT SIDE WHILE SHAPING THE RIGHT SIDE

There are different ways to hold stitches on one side while completing the other side. Usually, we tell you to bind off the center sts. for neck and put the left side into holding position while completing the right side. The easiest way and really the best way for beginners is to take a piece of RAVEL CORD and hand knit the center neck stitches, pulling them back against the needle bed of machine to the "A" or out of work position. The stitches remain in the HOOKS of the needles so you are really only knitting them HALF WAY. With another color of Ravel Cord, knit the remaining sts. on the left side in the SAME WAY.

It is important to protect these held stitches in some way—so you can either hang a REVERSING BAR so that the EYES of the Bar go BETWEEN the Gate Pegs on the machine and that the UPPER TIPS of Bar only—show above the needle bed...OR the simplest way is to use a piece of 1 inch masking tape and GENTLY place it beneath the knitting—right below the gate pegs. Do NOT press the tape—only enough pressure to hold it in place. This will prevent the Carriage (or Slide) from marking the held section.

It is VERY IMPORTANT that you mark the PATTERN ROW where you divide for the split for NECK (or SHOULDER) shaping.... If you are using a PUNCH CARD—MARK THE CARD—if you are using an ELECTRONIC machine, MARK THE DESIGN WINDOW. Also take note of the Row number for the division. When you are ready to work the left section, bring the HELD stitches back to B (working) position by pulling each end of the Ravel Cord GENTLY and rip it off—be sure to align all needles straight in the B or knitting position.

Now you are ready to REFER TO YOUR OWN INSTRUCTION MANUAL for your machine—to set the controls to begin knitting the left half. The neck stitches can be bound off after completing the right side or you can leave them in hold until each side is finished, then bind them off or remove them onto contrast waste yarn ready to be picked up for knitting a neckband or for other finishing.

FULL FASHION DECREASING OR INCREASING

For Stockinette stitch, use the Full Fashion method for decreasing or increasing (except for regular cap shaping on sleeves where you decrease the edge stitch).

TO DECREASE: Hang the 3rd stitch onto the 2nd stitch then move the end stitches in to fill the empty needle.

TO INCREASE: Move the 2nd end stitches 1 needle outward, then pick up the 3rd stitch from the row below and hang it onto empty needle.

PATTERN SYMBOLS

() Symbol for 2nd size.

[] Symbol for 3rd size.

There are up to 3 sizes given for Patterns in KNITTING MAGAZINE. For example, the Charts and printed instructions will show the cast-on as...124—First size. [132]—Second size. [140]—Third size.

R = ROW

◻ Needles in holding position.

⊗ Needles back into working position.

< For Short Row Knitting

THE SAMPLE SWATCH

Before you knit any garment, you must knit a sample swatch using the yarn you have chosen for your garment. If you do not get the correct Stitch and Row Gauge as given for a Pattern in KNITTING MAGAZINE—try different tensions. If you are using the specified yarn, you should be able to get the correct gauge using one of the tensions shown. If you are using other yarns, you may have to make several swatches—but the gauge is very important.

To make a sample swatch—Cast on 60 stitches with waste yarn and knit 6 rows. Mark the tension number for your sample swatch by making holes (you can do this with a Lace Carriage or by hand), 4 transfers for Tension 4, 6 transfers for Tension 6, etc. Knit 6 more rows.

Change to garment yarn and set Counter at 0. Knit 30 rows (in Stockinette stitch or Pattern stitch—according to the garment). With contrast waste yarn knit the 10th stitch FROM EACH SIDE—by hand. Knit 30 rows. Change to waste yarn and knit 12 rows. Remove the sts. from the machine by pushing the Carriage (or Slide) across without yarn.

Pull and stretch the sample swatch both lengthwise and diagonally from corner to corner, then lengthwise again. Gently block the swatch (KNITTING PRESSING CLOTHS are great for this)—or you can allow the sample to rest several hours or even over night so that the stitches can return to their basic form. USE KNITTING CONVERTA TAPE for MEASURING YOUR SAMPLE (or the KNITTING INSTANT STITCH AND ROW GAUGE MEASURE).

If you use the Converta Tape, pull out the Tape to measure BETWEEN the 40 marked stitches in the center of your swatch. Move the red marker on the Tape so that it points to 40 stitches on the TAPE. Your stitch gauge to 2" (5 cm) will show in the RED WINDOW. To find the number of rows in 2" (5 cm), place the Tape to measure over the 60 rows, push the red marker to 60 on the Tape and your row gauge for 2" (5 cm) will show in the red window.

If you do not own a KNITTING CONVERTA TAPE or a Stitch and Row Measure, you must count the number of stitches and rows to 2" (5 cm) after marking a 2-inch square in the center of your knitting.

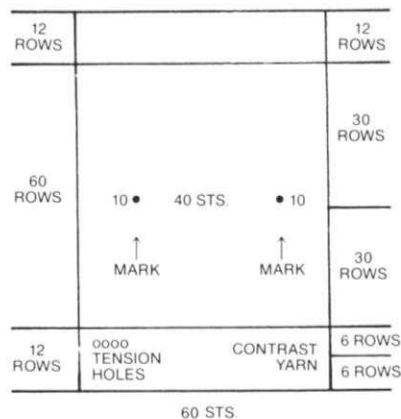

FINISHING

Gently block all sections—For PULLOVERS, JACKETS and DRESSES: Join the front to back at shoulders and sides. Sew sleeves together and set in. Hem lower edge and sleeve edges if needed. For a double neckband or armhole, band sew 1 edge to inside and 1 to the outside of neck or armhole. For a single ribbed band, sew 1 edge to the outside of neck or armhole edge. For a cardigan or jacket with buttonholes, finish buttonholes and sew on buttons.

PANTS: Join front to back at sides. Sew inside leg seams, then join to center front and back. Make hem at waistline and insert elastic. Hem lower edge of pants' legs.

◻ Needle not used—in out of work position.

3x1

◻ The number in the box is the number of Rows between shapings. The 3 x 1 above the box gives you the sts. and number of times to make the decreases (or increases)—FOR EXAMPLE: 3 x 1 over the box with 4 means—At the given Row number, *decrease 1 st. knit 4 rows* and REPEAT from * to * 2 times more for a total of 3 times in all. All decreasing (or increasing) WITHOUT ROW NUMBER IN BOX must be made on EVERY 2nd ROW.



WOMENS PULLOVER

SIZES: 10/12 (14/16)
 YARN: Venetia and Angora
 AMOUNT:
 color 1 1/2 lb. Venetia } all
 color 2 1/2 lb. Venetia } sizes
 color 3 2 balls Angora }
 TENSION: 6 Rib. 2/2 11
 GAUGE: 14 sts. 21 rows = 2" (5 cm)

Stockinette stitch with Short Rows for the Design. Bands are K1, P1 Ribbing.

BACK & FRONT THE SAME.

With color 1, cast on 144 (156) sts. and work 40 rows K1, P1 Ribbing. Transfer the ribber sts. to main machine and with color 2, continue in Stockinette stitch.

Knit to Row 136 (142).

Change to color 1.

Knit to Row 150 (156) then begin the Design.

ON EACH SIDE, put into holding position 41 (47) sts.

Attach Angora and work SHORT ROWS over the center 62 sts.

*ON CARRIAGE SIDE AND ON OPPOSITE SIDE OF CARRIAGE (at the same time) put into holding position 1 needle. Use ANGORA and KNIT 1 ROW. REPEAT FROM * until 4 needles remain in work in the center. (You do not need to wrap). Do not knit over the center 4 needles - bring them into holding position. Break Yarn.

Carriage on the right side.

Attach color 1 and push 41 (47) needles to work. Knit to the left and wrap inside needle in holding, knit to the right.

Push back 3 needles, knit across and bring 1 back to holding position (automatic wrap). Continue in this way, always pushing back 3 needles knit across and bring up 1 till 1 is left in holding to the right of 0.

Break yarn, bring all needles to holding position and move Carriage to the left side.

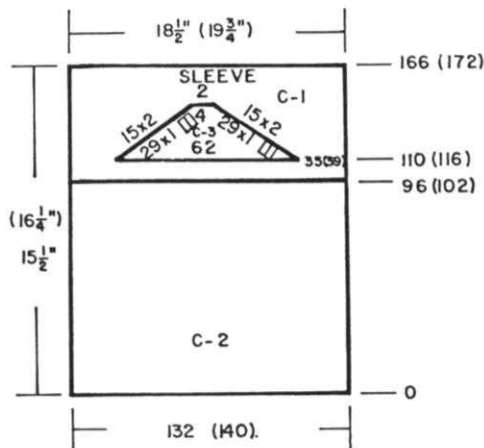

SLEEVES:

OPEN CAST ON with waste yarn, 132 (140) sts. After Knitting 9 to 11 rows, knit 1 row with Ravel Cord to the right side. Change to color 2 and put counter at 0.

Work Stockinette stitch. Knit to Row 96 (102)

Change to color 1 and knit to Row 110 (116).

ON EACH SIDE, put 35 (39) sts. into holding position.

Work the SHORT ROWS over the center 62 sts. the same as you did for FRONT AND BACK. When Design is completed, continue stockinette stitch with color 1 to Row 166 (172)

Remove the sts. onto contrast waste yarn.

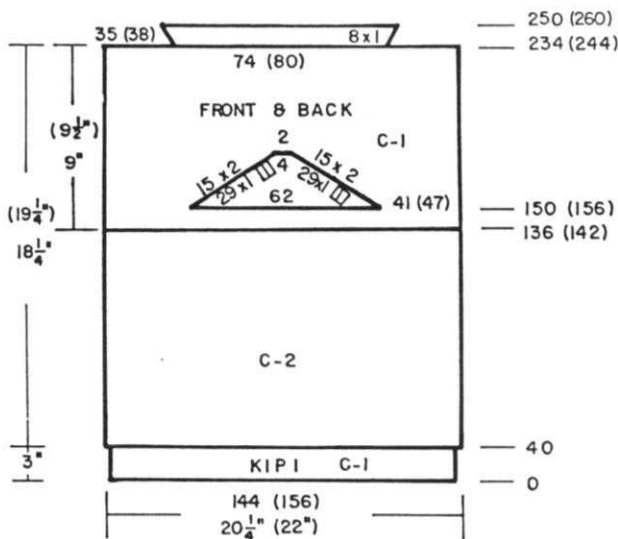

Work the left side same as right side. until 2 needles are left (1 each side of 0) All needles in working position and continue Stockinette stitch to Row 234 (244).

ON EACH SIDE, remove 35 (38) sts. onto waste yarn for shoulder.

Over the remaining sts. make facing. ON EACH SIDE, increase 1 st. every 2nd row 8x.

After Row 250 (260) bind off loosely.

Make 2nd section the same.

CUFF:

With color 1, cast on 65 (69) sts. and work 40 rows K1, P1 Ribbing. Transfer the ribber sts. to main machine.

Hang the open sts. of sleeve onto these needles decreasing evenly across.

Knit 1 very loose row, then bind off the crochet method.

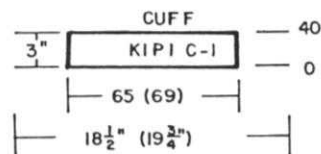

FINISHING:

See General Instructions. Fold neck facing to the inside and sew loosely in place.

Knitting at a different speed can change the tension gauge so try to move the carriage smoothly.





WOMENS PULLOVER

SIZES: 8/10 (12/14)
YARN: BULKY Venetia & Angora
AMOUNT:
 color 1 1 lb. Venetia
 color 2 3 balls Angora
TENSION: 0 for back and sleeves.
 1 for INTARSIA (front)
RIBBING: 6/6 I Standard Ribber
GAUGE: 10.5 sts., 17 rows = 2"

Made on the KH 230 BULKY machine and with STANDARD MACHINE & Ribber. The VERTICAL STRIPES on front and back are a NEEDLE OUT OF WORK and LATCHED UP LATER to form a pur1 side on the knit side. BE SURE TO PLACE A STITCH ON THE EMPTY NEEDLES WHEN WORKING THE ROWS WITH ANGORA, then empty the needles (transfer stitch to neighboring needle) when each Angora section is completed.

BACK:

With color 1, cast on 131 (141) sts. (STANDARD MACHINE & RIBBER). Work 26 rows K1, P1 Ribbing. Transfer the ribber sts. to main machine, knit 1 row then remove the sts. onto contrast waste yarn. ON BULKY MACHINE, bring 98 (106) needles into working position then hang the open sts. of band onto these needles, doubling every 3rd stitch. COUNTER AT 0. Transfer the 21st stitch ON EACH SIDE to neighboring needle and push the needle OUT OF WORK (A) position. Continue in Stockinette stitch. Knit to Row 152 (160). Bind off the center 22 (26) sts. put the needles on the left into holding position and complete the right side first. *ON NECK SIDE, bind off 12 sts. 1x, 1 st. 2x. After Row 160 (168), remove the sts. onto contrast waste yarn. Bring the needles on the left into working position, knit 1 row to the left side, turn the Row Counter back to 152 (160) and complete the left half. Follow the instructions from *. ON THE PURL SIDE, LATCH UP THE EMPTY STITCH INTO A KNIT STITCH ON EACH SIDE.

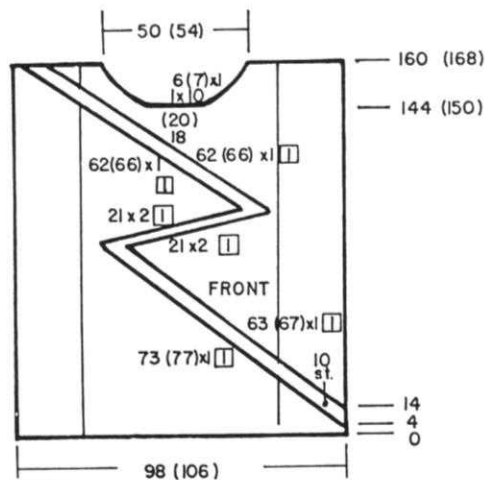

FRONT:

Work the front the same as the back with the EXCEPTION of INTARSIA DESIGN AND NECK SHAPING. When Ribbing is completed, begin the Intarsia Design after Row 4. Begin with 1 st. in Angora and ON EVERY ROW, move the Angora 1 st. to the LEFT until there are 10 sts. in design then continue to move ALL 10 sts. 1 stitch to the LEFT on EVERY ROW (SEE CHART). Continue to FOLLOW CHART but now MOVE DESIGN 2 STITCHES OVER to the RIGHT on every row. (See Chart) When this is completed, go back to moving design 1 st. over on every row. AT THE SAME TIME, after Row 144 (150) Bind off 18 (20) center sts., put the needles on the LEFT into holding position and complete the right side first. *ON NECK SIDE, bind off 10 sts. 1x, 1 st. 6x (7x). After Row 160 (168), remove the sts. onto contrast waste yarn. Bring the needles on the left into working position, knit 1 row to the left side, turn the Row Counter back to 144 (150) and complete the left half. Follow the instructions from * (don't forget to continue design).

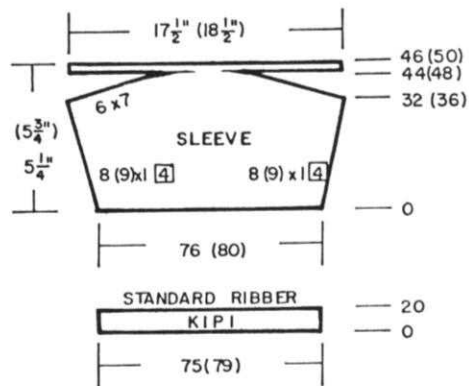
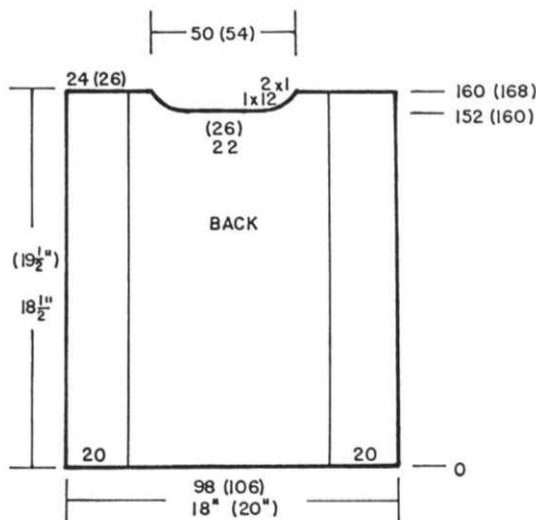
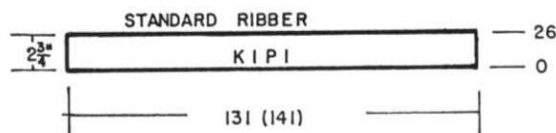

SLEEVES:

Cast on 75 (79) sts. with color 1 and work 20 rows K1, P1 Ribbing SAME AS YOU DID FOR FRONT AND BACK. After transferring to BULKY MACHINE, increase 1 st. on the right side. COUNTER AT 0. ON EACH SIDE, increase 1 st. every 4th row 8x (9x). After Row 32 (36) Work Short Rows. ON OPPOSITE SIDE OF CARRIAGE bring into holding position 7 sts. 6x ON EACH SIDE. After Row 44 (48) bring needles opposite carriage into working position before knitting the next 2 rows. Remove the sts. onto waste yarn (or you can bind off loosely).

FINISHING:

See General Instructions. With a E crochet hook (or whatever is easiest for you) work 1 row of slip stitch crochet using angora around armhole from the RIGHT SIDE. With angora, work 1 row single crochet around neckline. Row 2, single crochet, *chain 3, skip 1, single crochet and repeat from * around. Row 3.*double crochet, ch 3, slip st. into first ch, double crochet - all into same loop. Skip 1 loop and REPEAT FROM *. Sew on approximately 50 beads on the front as shown in picture.



WOMENS SIESTA TUNIC

SIZES: 6/8 (10/12) [14/16]
 YARN: Cordella
 color 1 7 8 8 balls
 color 2 1 ball for all sizes.
 TENSION: 8 Rib. 3/3 I
 GAUGE: 14 sts. 19 rows = 2" (5 cm)

Made on the KH 910 with KR 900 Ribber. Can be made on any Electronic machine with Ribber. Ribbing with color stripes and ISOLATED DESIGN on the Front Section. SPECIAL FULL NEEDLE RIBBING (See KNITTING MAGAZINE Practical Knitting Hints, Volume 20, No. 1 for special ribbing instructions). Send \$1.00 plus self addressed stamped envelope for full size copy of design.

TUNIC FRONT:

With color 1, cast on 128 (142) [156] sts. and work FULL NEEDLE SPECIAL RIBBING. Work 8 rows EACH of colors 1, 2, 1, 2, 1 and after Row 40, transfer the ribber sts. to main machine and continue in Stockinette stitch with color 1 to Row 101 (111) [121] then SET PATTERN from LEFT TO RIGHT.

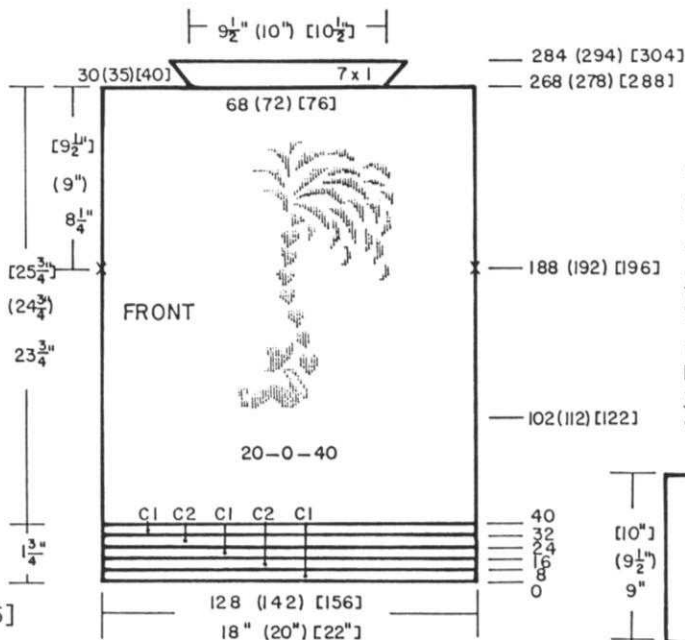

Continue in ISOLATED FAIR ISLE PATTERN. After Row 188 (192) [196], MARK EACH SIDE with a bit of yarn for setting in sleeves. When Pattern is completed, continue in Stockinette stitch with color 1 to Row 268 (278) [288]. ON EACH SIDE, remove 30 (35) [40] sts. onto contrast yarn for shoulder. Make facing over the remaining sts. ON EACH SIDE, increase 1 st. every 2nd row 7x. After Row 284 (294) [304], bind off loosely.

BACK:

Work the BACK the same as the front but OMIT THE DESIGN.

SLEEVES:

With color 1, cast on 124 (132) [140] sts. and work THE SAME FULL NEEDLE RIBBING as you did for front and back. After Row 40, continue in Stockinette stitch with color 1 to Row 128 (132) [136]. Mark the CENTER with bit of contrast yarn, then remove the sts. onto contrast waste yarn.

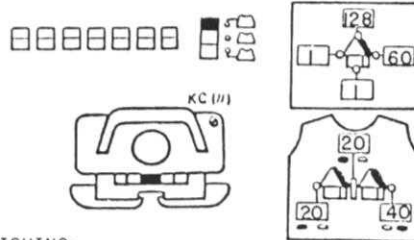
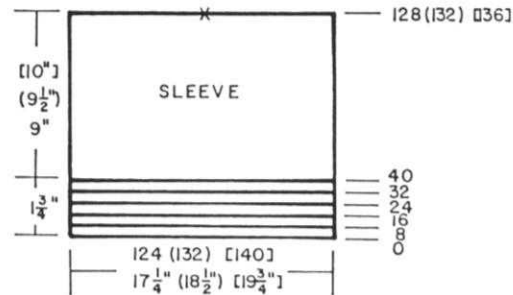

FINISHING:

Close shoulders first, then set in sleeves from mark to mark. You can hang sleeve opening from mark to mark with right side facing you, then hang open sts. of sleeve with WRONG side facing and knit 1 row then bind off - or you can slip stitch the sleeves into place. Close side seams. Turn neck facing to the inside and sew loosely in place.



WOMENS TOP & SKIRT

SIZES: 6/8 (10/12) [14/16]
 YARN: Beatrice
 AMOUNT:
 color 1 6 6 6 balls
 color 2 5 5 5
 TENSION: 6
 TOP - 15 sts. 21 rows = 2"
 RIB: 3/2.2 II
 SKIRT: Ten. 5
 RIB: Full Needle 3/3 I
 GAUGE: 16 sts. 23 rows = 2"

Top is knitted sideways on the machine in a Fair Isle Design with bands in K1, P1 Ribbing. Punch 3 cards and connect them together. Skirt is Stockinette stitch with lower band in full needle ribbing.

SKIRT: Make 2 sections the same.

FULL NEEDLE RIBBING. Cast on 154 (164) [174] sts. and work full needle ribbing to Row 10. COLOR 1. Transfer the ribber sts. to main machine. Continue in Stockinette stitch. After Row 90 (94) [98], Mark right side for side slit. Knit to Row 210 (220) [230]. Remove the sts. onto contrast waste yarn. Bring 140 (149) [158] needles to working position. Pick up the open sts. of skirt and hang onto these needles decreasing by hanging approximately every 10th and 11th st. together. Counter at 210 (220) [230]. Knit to Row 242 (252) [262]. Remove the sts. onto contrast waste yarn. Bring 126 (134) [142] needles to working position then hang the open sts. as you did before. Counter at 242 (252) [262]. Knit to Row 274 (284) [294]. Remove onto waste yarn. Make second section the same.

WAISTBAND: Make 2.

Bring 114 (122) [130] needles to working position. With wrong side facing you, hang the open sts. of skirt onto these needles, decreasing across as you did before. Knit 24 rows, Hang the hem then bind of loosely.

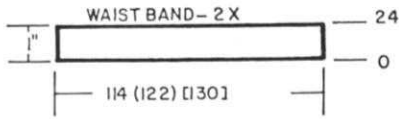

BACK SLIT BAND: FULL NEEDLE RIB.

With color 1, cast on 50 (54) [58] sts. and work full needle ribbing with tension 3/3 I to Row 10. Transfer the ribber sts. to main machine, knit 1 row then with wrong side facing you, hang the back edge of slit onto these needles from lower edge to mark. Bind off.

BANDS FOR THE SLIT

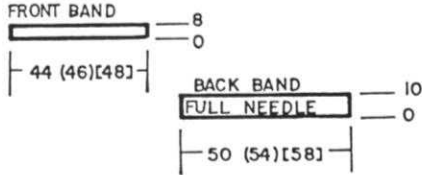

FRONT SLIT BAND: Stockinette st.

With wrong side facing you, pick up the LOOPS from front slit 44 (46) [48] sts. With tension 5.1, knit 8 rows. Remove the sts. onto contrast waste yarn. Fold band to the inside and hem in place going through the open sts. Remove waste yarn.

SKIRT FINISHING: See General Instructions. Fold front slit band over to the inside and hem in place. Sew down top of back band on the inside.

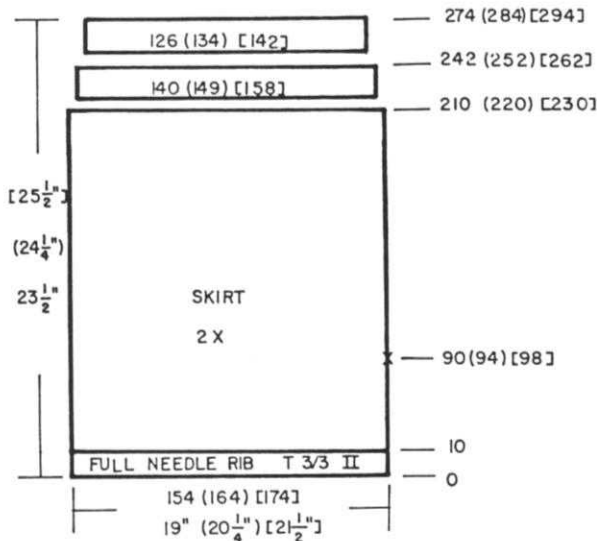

TOP BACK:

With contrast waste yarn, begin with NEEDLE 85 to the LEFT OF 0 and cast on 64 (68) [72] sts. from LEFT TO RIGHT.

Knit 9 to 11 rows then 1 row Ravel Cord to the right. Counter at 0 and change to COLOR 1.

Work Stockinette stitch to Row 70 (74) [78].

ON THE RIGHT, increase 1 st. every 3rd row 30x BUT AT THE SAME TIME, after Row 94 (102) [110], SETTING THE PATTERN A LEFT TO RIGHT BEFORE KNITTING THE LAST ROW. Continue Pattern. After Row 160 (164) [168], ON THE RIGHT, 'e' cast on 6 sts. 4x, 5 sts. 4x (8 sts. 6x) [7 sts. 4x, 6 sts. 4x]

ALL SIZES, cast on 10 sts. 1x. (If you want to, you can use a cast on rag to cast on these sts.)

Continue in Pattern to Row 220 (228) [236]. STOP PATTERN.

Knit 1 row to the left WITH COLOR 2.

Bind off 7 sts. then knit to Row 271 (283) [295]. MARK LEFT EDGE FOR CENTER.

Knit to Row 321 (337) [353]. Cast on 7 sts. with color 2. TURN PUNCH CARD UPSIDE DOWN AND COMPLETELY OVER TO THE OTHER SIDE. Remove clips and attach cards together PROPERLY. Insert into machine and ROLL CARD TO ROW 7 for Pattern B. SET PATTERN FROM LEFT TO RIGHT ON NEXT ROW.

Continue in Pattern B to Row 366 (386) [406].

ON THE RIGHT, bind off 10 sts. then bind off

5 sts. 4x, 6 sts. 4x (8 sts. 6x)

[6 sts. 4x, 7 sts. 4x].

After Row 385 (405) [425]

ON THE RIGHT, decrease 1 st. every 3rd row 30x BUT AT THE SAME TIME, after Row 448 (464) [480], CHANGE TO COLOR 1 and CONTINUE IN STOCKINETTE STITCH.

After Row 542 (566) [590], remove onto contrast waste yarn.

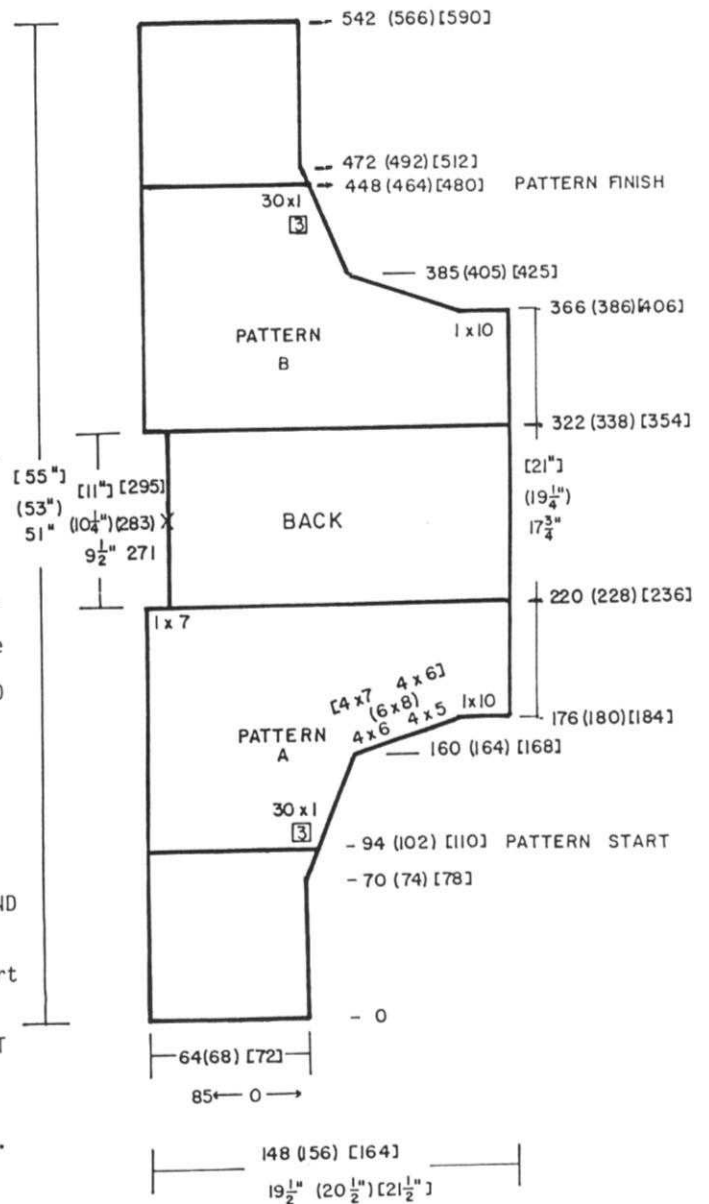

TOP FRONT: MAKE BACK FIRST.

The front is worked the same as the back with exception of NECK SHAPING. After Row 221 (229) [237] bind off 7 sts. 1x, then ON NECK SIDE, bind off 1 st. every 4th row 3x. 1 st. every 8th row 4x. After Row 271 (283) [295], mark edge for center neck. After Row 281 (297) [313], INCREASE 1 st. every 8th row 4x, every 4th row 3x. After Row 321 (337) [353], cast on 7 sts. and complete the front following the Chart.

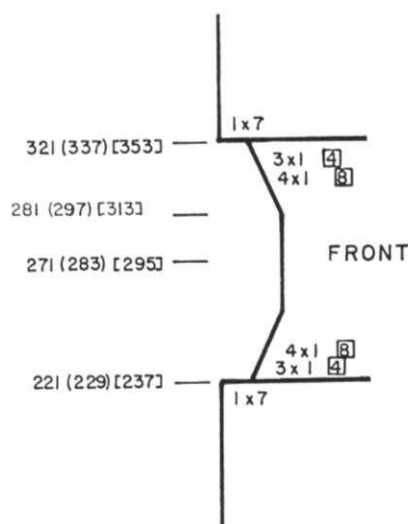

CONTINUED

NECK BANDS: Make 2.

K1, P1 Ribbing.

With color 2, cast on 81 (87) [93] sts. and work 14 rows of ribbing. Transfer the ribber sts. to main machine. With wrong side facing you, pick up sts. along one neck edge and hang onto machine. Bind off through the double sts. LOOSELY.

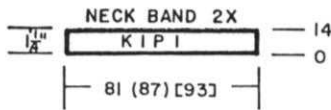

SLEEVE BANDS: Make 2.

K1, P1 Ribbing.

CLOSE TOP EDGES OF SLEEVES AND SHOULDERS FIRST.

With color 1, cast on 69 (73) [77] sts. and work 34 rows of ribbing. Transfer the ribber sts. to main machine. Hang the open sts. of sleeve onto these needles—approximately 2 sts. 5x, 1 st. 1x across. Knit 1 row then bind off LOOSELY.

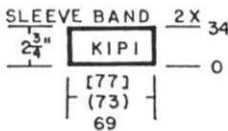

WAISTBAND: Make 2.

K1, P1 Ribbing.

With color 1, cast on 139 (149) [159] sts. and work 36 rows of ribbing. Transfer the ribber sts. to main machine. Pick up sts. of waist edge evenly. Knit 1 row then bind off LOOSELY.

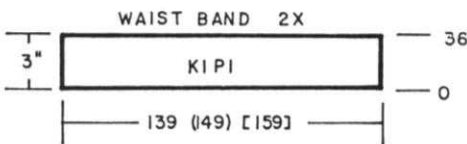

FINISHING: See General instructions. Weave the edges of neckband to sleeve.

PAT. 1

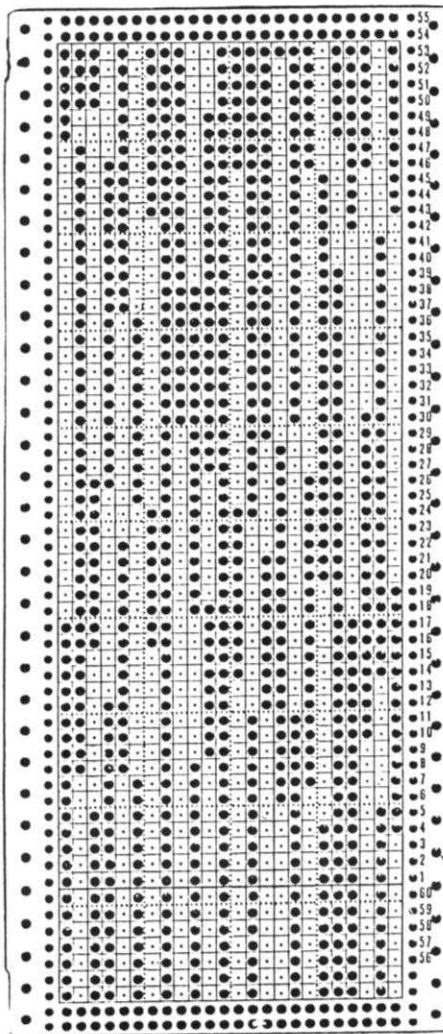

PAT. 2

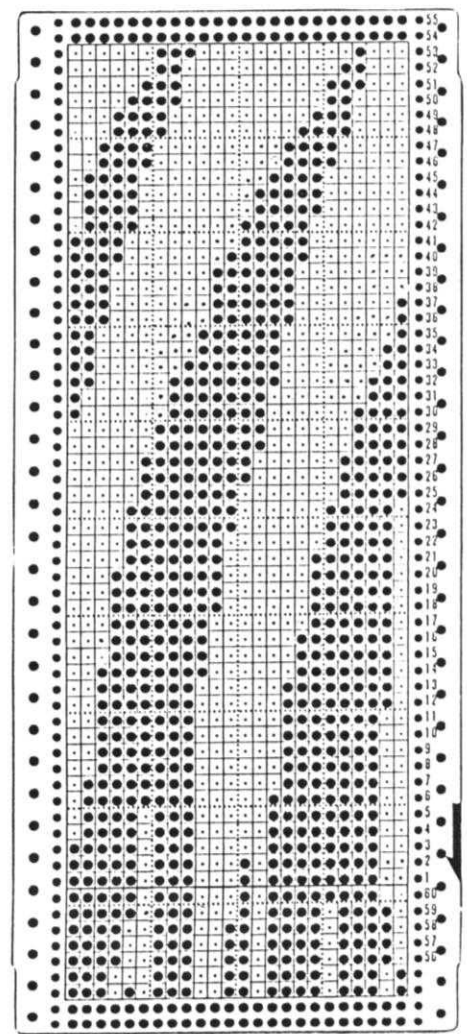

PAT. 3

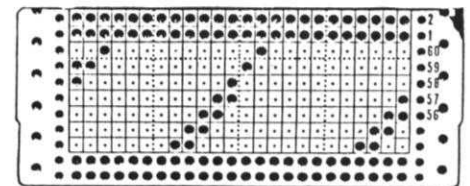

WOMENS TWO-PIECE DRESS

SIZES: 6/8 (10/12) [14/16]
 YARN: Venetia
 AMOUNT: 2 lbs. for all sizes.
 TENSION: 4 Rib. 1/1 II
 GAUGE: 16 sts. 26 rows = 2" (5 cm)

Skirt is Stockinette stitch. The Top is Stockinette stitch with isolated Lace Design. Full needle ribbing for lower edge of skirt. 1 x 1 ribbing for Top bands.

SKIRT: Front and back the same.
 FULL NEEDLE RIBBING, Tension 4/3 II.
 Cast on 158 (172) [186] sts. and work the full needle ribbing to Row 14. Transfer the ribber sts. to main machine and continue in Stockinette stitch with Tension 4. Knit 2 rows then work SHORT ROWS.

ON OPPOSITE SIDE OF CARRIAGE, bring into holding position 50 sts. before knitting the next 2 rows.
 ON OPPOSITE SIDE OF CARRIAGE, push back into working position 10 sts. 5x ON EACH SIDE. (BE SURE TO WRAP the inside needle in holding position to prevent a hole while knitting short rows).
 Continue in Stockinette stitch AND ON EACH SIDE, decrease 1 st. immediately then decrease 1 st. every 48th (50th) [50th] row 5x.
 ON EACH SIDE, decrease 1 st. every 7th (9th) [10th] row 7x.
 After Row 320 (334) [348], remove the remaining sts. onto contrast waste yarn.
 Make 2nd section the same.

SPECIAL LACE INSTRUCTIONS

FRONT DESIGN: The 'V' design on the front is outlined with **HAND TRANSFERS** for the edge eyelets. Follow the **DRAWING** for these hand transfers.

The first transfer for point - transfer the center needle to the left. Knit 2 rows.

Transfer the next 2, right to right, left to left, knit 2 rows and repeat again.

Continue in this way, following the outline drawing to row 76.

Make outline transfers **FIRST**, then program and set Lace Pattern.

***IMPORTANT:** - PUSH BACK TO B POSITION ALL SELECTED NEEDLES THAT ARE OUTSIDE THE HAND TRANSFERS ON EACH SIDE BEFORE USING LACE CARRIAGE TO MAKE THE ACTUAL TRANSFERS IN THE CENTER. Knit 2 rows.

Make the hand transfers then use Lace Carriage to select the needles and continue from *.

FOR THE SLEEVE LACE DESIGN, follow the above instructions using the **SLEEVE DRAWING** for the **OUTLINE TRANSFERS**.

CHART FOR FRONT

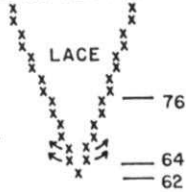
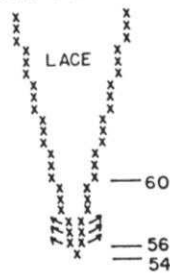

CHART FOR SLEEVES



TOP FRONT:

Cast on 151 (163) [175] sts. and work 40 rows K1, P1 Ribbing. Transfer the ribber sts. to main machine. Increase 1 st. on the right edge.

Continue in Stockinette stitch to Row 62. FOLLOW THE SPECIAL INSTRUCTIONS for the Lace Design making the hand transfers till Row 74 and continuing with the special instructions.

AT THE SAME TIME, after Row 184 (190) [196], **SHAPE ARMHOLE:** ON EACH SIDE, bind off 6 sts. 1x, 5 sts. 1x, 3 sts. 2x (3x) [3x], 1 st. 6x (6x) [8x].

AT THE SAME TIME, after Row 206 (210) [214], put half the sts. on the left to holding (A) position. (To put stitches into 'A' position - knit each st. with ravel cord by hand and push elongated st. back to 'A' position on main bed.)

Complete the right side first. Mark ROW ON PATTERN SHEET.

* ON NECK SIDE, decrease 1 st. every 3rd row 25x (26x) [27x]. After Row 288 (300) [312] put the sts. onto waste yarn or bind them off.

Bring the needles on the left to working (B) position, MAKE SURE ALL STITCHES ARE IN THE HOOKS OF NEEDLES. Return Pattern to correct row number.

Counter back to 206 (210) [214]. Use Lace Carriage first and follow instructions from *.

TOP BACK:

The back is worked the same as the front BUT OMIT THE PATTERN AND SHAPE NECK after Row 276 (288) [300], bind off the center 16 (18) [20] sts. Put the needles on the left into holding position and complete the right side first.

* SHAPE SHOULDER AND NECK AT THE SAME TIME.

FOR SHOULDER, bind off 5 sts. 4x, 4 sts. 2x (5 sts. 6x) [6 sts. 3x, 5 sts. 3x].

FOR NECK, bind off 7 sts. 2x, 1 st. 3x.

Bring the needles on the left into working position, knit 1 row to left side, turn the Row Counter back to 276 (288) [300] and complete the left half. Follow the instructions from *.

SLEEVES:

Cast on 85 (91) [97] sts. and work 36 rows K1, P1 Ribbing. Transfer the ribber sts. to main machine and increase 1 st. on the right side.

Continue in Stockinette stitch. ON EACH SIDE, increase 1 st. every 5th row 14x (15x) [16x], BUT AT THE SAME TIME, after Row 54, begin the outline transfers as shown on the sleeve drawing and follow the special instructions for sleeve transfers. The Lace Carriage will be used after Row 68.

After Row 110 (116) [122] **SHAPE CAP:**

ON EACH SIDE, bind off 4 sts. 1x, 3 sts. 1x, 2 sts. 1x, 1 st. 4x, then 1 st. every 4th row 14x (15x) [16x], then 1 st. EVERY ROW 5x (6x) [7x].

ON EACH SIDE, bind off 2 sts. 6x. Remove the remaining stitches onto contrast waste yarn or bind off.

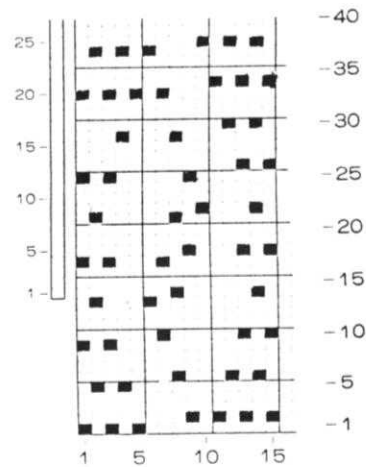
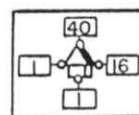
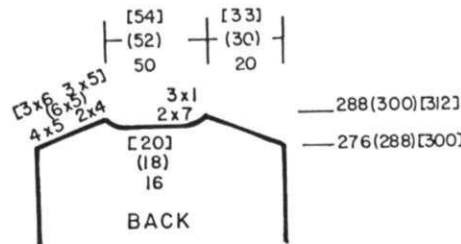
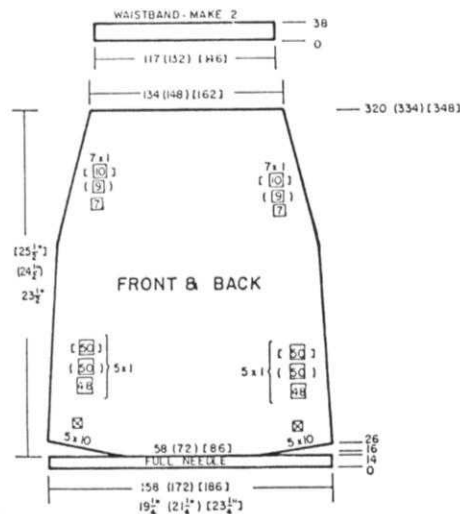
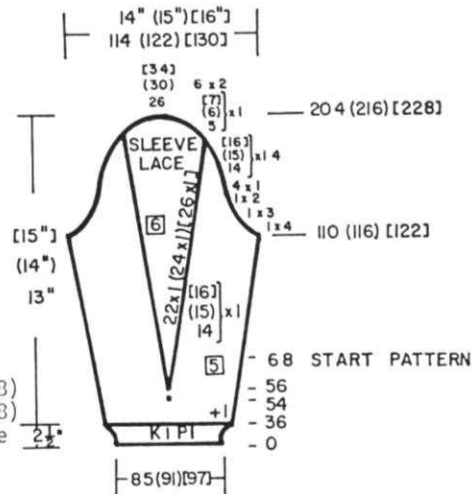
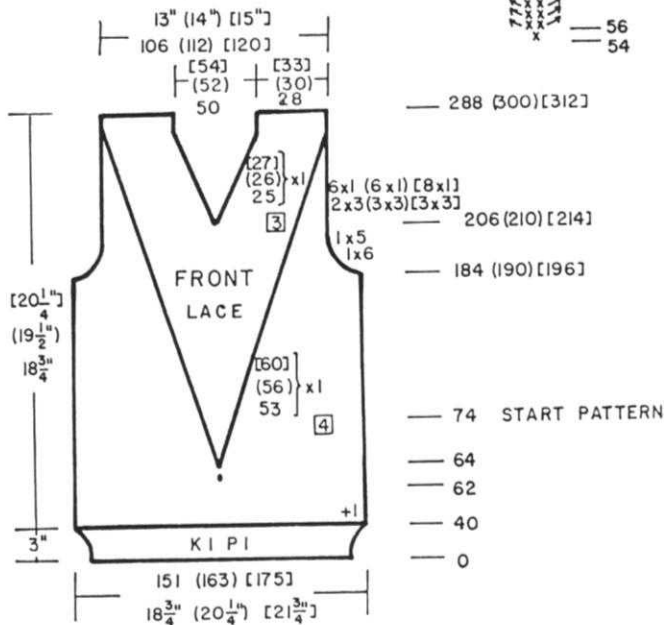



RIGHT FRONT: Reverse for left.
 'e' Cast on 60 (68) sts. with color 1 and work the same as back to Row 212 (222). FRONT NECK SHAPING: ON NECK SIDE, decrease 1 st. every 10th row 17x (every 8th row 20x) but remember to mark side edge for sleeve after Row 266 (274). After Row 392 (408) remove the sts. onto contrast waste yarn. Make LEFT FRONT with Reverse shaping.

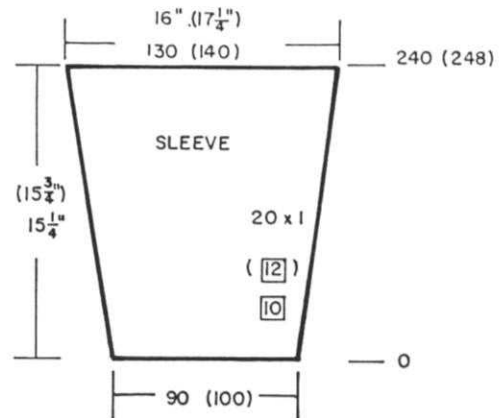

SLEEVES:

With contrast waste yarn, cast on 90 (100) sts. After Knitting 9 to 11 rows, knit 1 row with Ravel Cord to the right side. Change to color 1, counter at 0. Work in Slip Stitch Pattern and ON EACH SIDE, increase 1 st. every 10th (12th) row 20x. After Row 240 (248), remove the sts. onto contrast waste yarn.

CUFFS:

With color 1, cast on 45 (49) sts. and work 30 rows K1, P1 Ribbing. Transfer the ribber sts. to main machine. Hang the lower edge of sleeve held on waste yarn onto these needles, doubling every stitch. Knit 1 row slowly over the doubled sts. (bring the needles to E position first so the stitches will knit off). Bind off loosely.

WOMENS CARDIGAN

SIZES: 8/10 (12/14)
 YARN: Cordella
 AMOUNT:
 color 1 6 6 balls
 color 2 4 4 balls
 color 3 4 4 balls
 TENSION: 6 Rib. 5/5 I
 GAUGE: 16 sts. 31 rows = 2" (5 cm) in SLIP STITCH PATTERN.

A SLIP STITCH PATTERN worn on the PURL SIDE. Bands are K1, P1 Ribbing. Collar is K1, P1 Ribbing with SHORT ROWS. Use COLOR CHANGER FOR PATTERN. Punch Card.

BACK:

'e' Cast on with color 1, 154 (170) sts. and work 20 rows Stockinette stitch. Set PATTERN from RIGHT TO LEFT before knitting the next row. Continue in SLIP STITCH PATTERN beginning with 8 rows color 1, 8 rows color 2, 8 rows color 3 and REPEAT the color changes. After Row 266 (274), mark each side with bit of yarn for setting in sleeves. After Row 380 (396), bind off the center 30 (36) sts., put the needles on the left into holding position and complete the right side first. MARK ROW ON CARD. *ON NECK SIDE, bind off 9 sts. 1x, 6 sts. 1x, 3 sts. 1x, 1 st. 1x. After Row 392 (408), remove the remaining sts. onto contrast waste yarn. Mark row on Punch Card. Bring the needles on the left into working position, Select needles on marked row of card with both PART BUTTONS PUSHED IN and move Carriage from RIGHT TO LEFT with no yarn. Put Card on GO and Row Counter to 380 (396) and complete the left half. Follow the instructions from *.

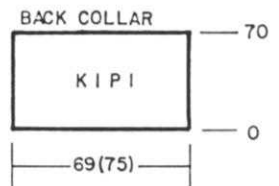
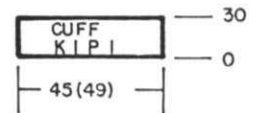
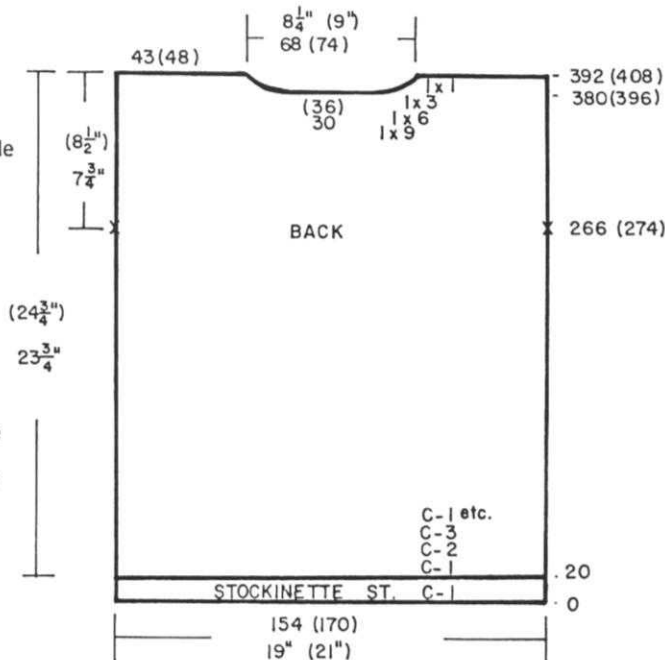
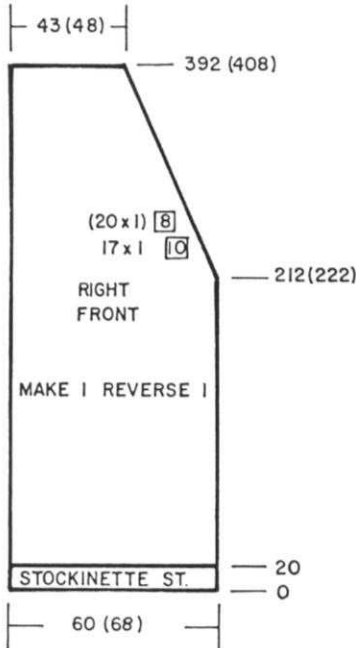

BACK COLLAR:

With color 1, cast on 69 (75) sts. and work 70 rows K1, P1 Ribbing. Transfer the ribber sts. to main machine then with knit side facing you, pick up sts. across the back of neck and hang onto same needles. Knit 1 loose row then bind off.

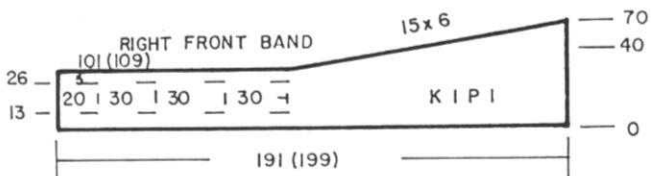

RIGHT FRONT BAND: 1 x 1 Ribbing.

With color 1, cast on 191 (199) sts. and work K1, P1 Ribbing. After Row 13, counting from the LEFT EDGE, MAKE BUTTONHOLES. Leave 20 sts. and with a piece of contrast yarn, knit the next 5 sts. (3 on main bed, 2 on ribber) by hand. Be sure to pull the ends of yarn down between the needle beds so that they won't catch) leave the next 30 sts. and make the next buttonhole over 5 needles same as before and REPEAT 2 times more for a total of 4 buttonholes. AFTER ROW 26, REPEAT the BUTTONHOLES OVER THE SAME NEEDLES in the same way.

After Row 40, WORK SHORT ROWS. (See Practical Knitting Hints this issue). ON OPPOSITE SIDE OF CARRIAGE, put into holding position, 101 (109) sts. then 6 sts. 15x.

After Row 70, all ribber sts. should now be on the main machine. With knit side facing you, pick up sts. along right front edge and hang onto machine. Knit 1 row over the doubled sts. then bind off loosely. MAKE LEFT FRONT BAND WITH REVERSE SHAPING AND OMIT THE BUTTONHOLES.

FINISHING: See General Instructions. Finish Buttonholes and sew on Buttons. Close back band to front bands to form shawl collar.

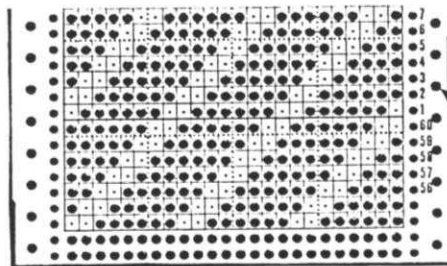

REPEAT the Punch Card through Row 49, then punch 2 rows of holes for connecting Card.

- Pick up the sts. held on waste yarn on opposite side. CARRIAGE ON THE RIGHT. Counter at 0. Knit 2 rows.
- Complete the stockinette stitch with SHORT ROWS same as you did for the other side. SEE CHART.



WOMENS FEATHER & FAN PULLOVER

SIZES: 6/8 (10/12) [14/16]
YARN: Cordella = color 1
Isabella = color 2
Angora = color 3

AMOUNT:
color 1 7 8 9 balls
color 2 2 2 2 balls
color 3 3 3 3 balls

TENSION: Knit Carriage - 8
Garter Carriage - 10

GAUGE: Knit Carriage, 13 sts. 19 rows
Garter Carriage, 13 sts. 18 rows
= 2" (5 cm)

K1, P1 Ribbing - Garter Carriage
Tension 3.

Knitted sideways on the machine in Stockinette stitch and Feather and Fan Design. K1, P1 Ribbing using the Garter Carriage. Punch Card.

For the 4th Pattern, Knit 4 rows Isabella, Make Lace, knit 2 rows Isabella Knit 2 rows Angora Knit 2 rows color 1. REMOVE GARTER CARRIAGE and FOLLOW LEFT FRONT AND BACK CHART and USE KNIT CARRIAGE. PLACE KNIT CARRIAGE ON THE LEFT SIDE. Counter 0. With color 1 knit 2 rows. SEE CHART. All needles in holding position. WORK SHORT ROWS. Push back into working position 14 (12) [18] sts. then 7 sts. 14x (6 sts. 18x) [5 sts. 22x]. Remove the right side 30 (32) [34] sts. onto waste yarn, then remove the remaining sts. onto another waste yarn.

LEFT FRONT & BACK

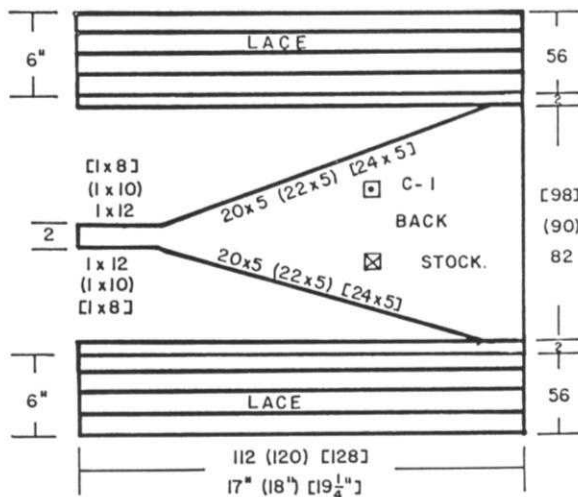
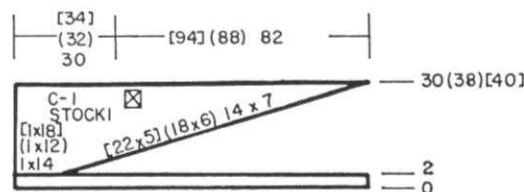

RIGHT FRONT & BACK

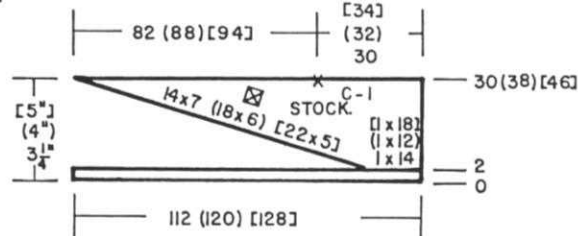

CONTINUED

BACK:

OPEN CAST ON WITH CONTRAST WASTE YARN USING KNIT CARRIAGE. 112 (120) [128] sts. Knit 2 inches ending on the right side. Change to GARTER CARRIAGE and SET PUNCH CARD. BEGIN PATTERN, following the special instructions along side the Punch Card and Pattern Chart. When counter reads 56, change to Knit Carriage and work Stockinette stitch with Short Rows. Knit 2 rows. Bring all the needles into holding position. PUSH BACK INTO WORKING POSITION 5 sts. 20 x (22x) [24x], with 8 (10) [12] sts. remaining. Knit 2 rows over all sts. ON OPPOSITE SIDE OF CARRIAGE, bring into holding position, 8 (10) [12] sts. 1x then 5 sts. 20x (22x) [24x]. Knit 2 rows. CHANGE TO GARTER CARRIAGE. Begin with 2 rows Angora, 2 rows color 1 NOW FOLLOW THE PATTERN INSTRUCTIONS FROM * TO * 3x IN ALL.

FRONT:

The Cast On, Feather and Fan Pattern and the sides are made exactly the same as the back. ONLY THE SHORT ROWS with stockinette stitch in the CENTER are different. Please follow the front Chart for the SHORT ROWS.

SLEEVES: CLOSE SHOULDERS FIRST.

Bring 164 (176) [188] needles into working (B) position. With wrong side facing you, pick up 82 (88) [94] sts. held on waste yarn from front and back sections, work Stockinette stitch. ON EACH SIDE, decrease 1 st. every 2nd row 16x. After Row 32, ON EACH SIDE, Decrease 1 st. every 4th row 22x. After Row 120, ON EACH SIDE, decrease 1 st. every 6th row 4x (5x) [6x]. After Row 164 (172) [180], remove the sts. onto contrast waste yarn.

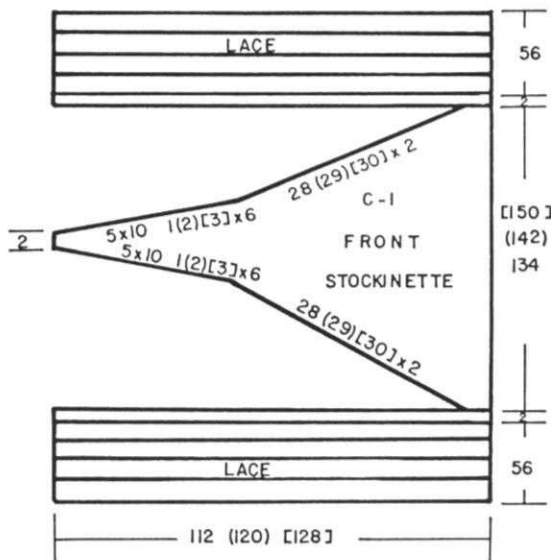

FEATHER AND FAN PATTERN USING THE GARTER CARRIAGE.

Set card on Row 1, card on STOP. IMPORTANT: Each step, requires you to set the counter of Garter Carriage for specified number of rows. Tension 8 - 2 rows color 1. (Remember to set card on GO WHEN CARRIAGE IS HALF WAY ACROSS THE FIRST ROW). Tension 10 - Knit 2 rows Angora * Tension 8 - Knit 4 rows Isabella SET PUNCH CARD ON ROW 9. Move the Lace Carriage 24 times (all needles are now in B position) Tension 10 - Knit 2 rows Isabella. Tension 8 - Knit 4 rows color 1. SET PUNCH CARD ROW 38. Move the Lace Carriage 24 times. (all needles now in B position) Tension 8 - Knit 2 rows color 1 Tension 10 - Knit 2 rows Angora.* REPEAT FROM * to * 2 times MORE (3 times in all). Tension 10 - Knit 4 rows Isabella SET PUNCH CARD ON ROW 9. Move the Lace Carriage 24 times Tension 10 - knit 2 rows Isabella. Tension 8 - Knit 2 rows color 1 Tension 10 - Knit 2 rows Angora. THIS COMPLETES THE PATTERN FOR ONE SIDE.

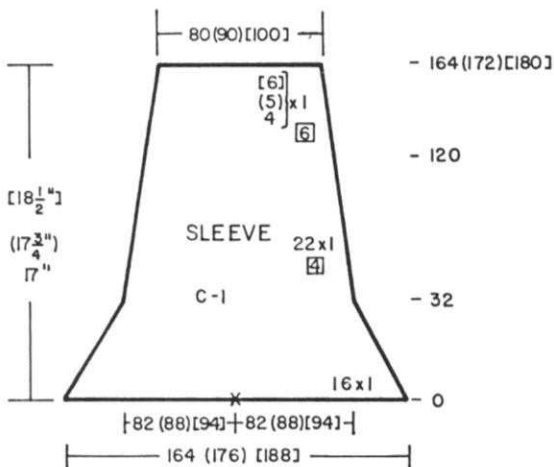

FEATHER & FAN PATTERN CHART

ANGORA	2
C-1	2
LACE ISABELLA	2
ISABELLA	4
ANGORA	2
C-1	2
LACE C-1	4
ISABELLA T8	2
ISABELLA T8	4
ANGORA T10	2
C-1 T8	2

SLEEVE BANDS:

1 x 1 ribbing with GARTER CARRIAGE. Use the 1 x 1 Card included with Garter Carriage. 'e' cast on 55 (61) [67] sts. Knit 29 rows. With wrong side facing you, pick up the open sts. of sleeve and hang onto needles, decreasing evenly across. Knit 1 loose row BY HAND from left to right then use the GARTER CARRIAGE and BIND OFF.

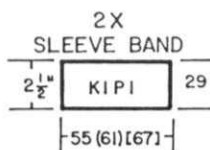

WAISTBAND: Make 2.

1 x 1 ribbing with GARTER CARRIAGE. Work the same way as for sleeve bands. Cast on 132 (142) [152] sts. Knit 39 rows. With wrong side facing you, pick up sts. along waist evenly then complete same as you did for the sleeve bands.

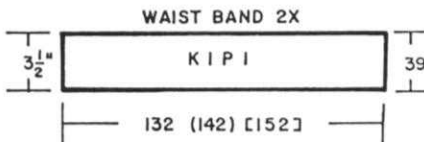

FINISHING:

See General Instructions. BE SURE THE PATTERN IS MATCHED AT SHOULDER. Single crochet 1 row around neckline.

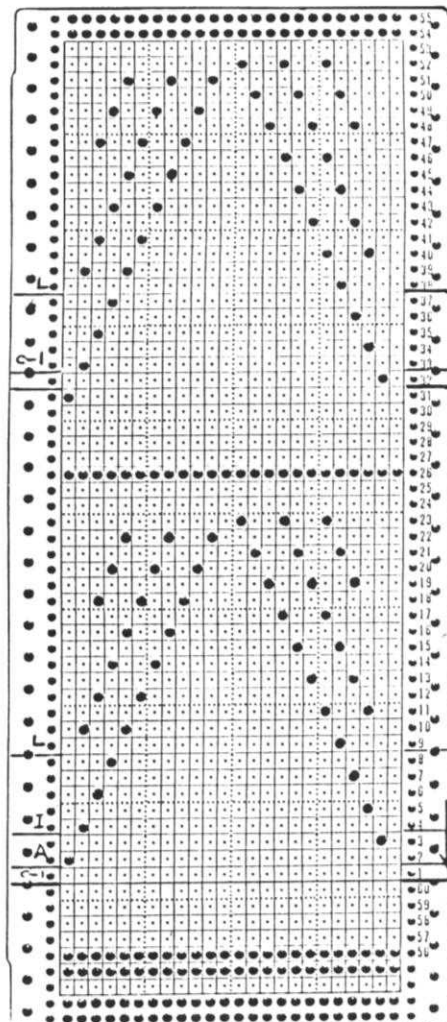



RUANA

SIZE: One size fits all
 YARN: Venetia (fine)
 AMOUNT: 1 1/2 lbs. color 1 Venetia
 1 oz. color 2 Venetia
 1 Spool Mami Rex (soft)
 TENSION: 1
 GAUGE: 24 sts. 20 rows = 2" (5 cm)
 94 BEADS approximately 3/8" diameter with large hole.

MOCK RIBBING - 2 needles in work, 2 needles out of work. Fringe at lower edges. Make 2 panels.

MACRAMÉ TO CLOSE THE SIDES

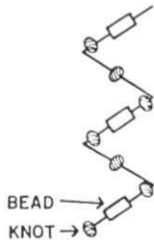

Bring all needles of machine to B position, then with selector, leave 2 in work, and push 2 out of work across needlebed ending with 2 in work. USE CROCHET CAST ON over needles in work (loosely) using color 1. Knit stockinette stitch and ON EACH SIDE, mark Rows 200, 400, 600, then after Row 800, bind off the crochet method making a CHAIN 1 between where empty needle is. Make a 2nd section the same.

MAKE 2 PANELS

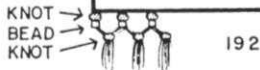
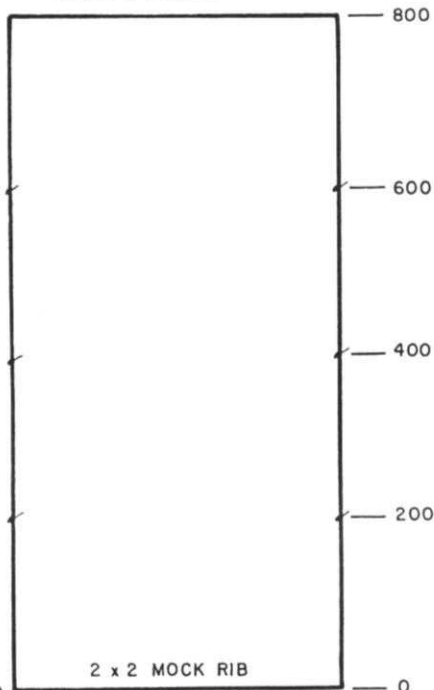

FINISHING:

Seam the two Panels together approximately 36" inches for back (leaving approximately 2" open for back neck. EDGING: With purl side facing and working around all edges a section at a time, hang edge onto machine needles and with 1 strand of color 2 Venetia and 1 strand of Mami Rex, knit 1 row with tension 7 from right to left. Transfer every other st. to needle on the left then bind off the crochet method around the gate pegs. Work Macrame to close sides. Thread large eyed tapestry needle with 2 strands Mami Rex, 4 strands color 1, 2 strands color 2 Venetia work zig-zag closing from 1 side to the other side as follows: Attach at one edge, make a knot before and after each bead (SEE DRAWING). FRINGE: Cut an 8" cardboard and using color 1, wrap yarn around cardboard 6x, 2x with Mami Rex, 1x with color 2. Cut 1 end only. Make 64 sets. Use a latch tool or large crochet hook and knot fringe sets about 1" apart. Thread bead on each set, then divide in half, make knot about 1" down (SEE DRAWING), Trim fringe.



WOMENS PULLOVER

SIZES: 6/8 (10/12) [14/16]
 YARN: BULKY Venetia
 AMOUNT: 1 1/2 lbs. for all sizes.
 TENSION: 2.2 Rib. 0/0
 GAUGE: 11 sts. 15 rows = 2" (5 cm)

Knitted on the KH 230 or KH 260 BULKY machine with Ribber. Stockinette stitch with Cable Design as shown on the Chart. Bands are K1, P1 Ribbing.

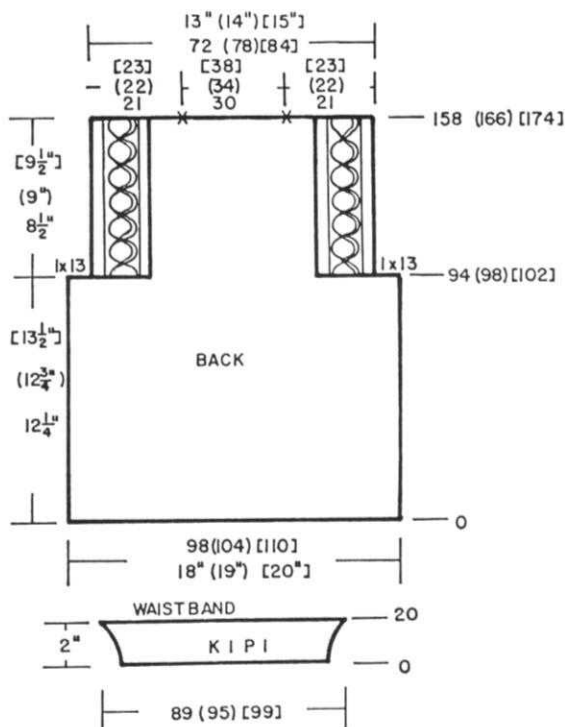

BACK:

Cast on 89 (95) [99] sts. and work 20 rows K1, P1 Ribbing. Transfer the ribber sts. to main machine then knit 2 rows Stockinette stitch and remove the sts. onto contrast waste yarn. Bring 98 (104) [110] needles into work then hang the open sts. of band onto these needles increasing EVENLY across. Continue in Stockinette stitch. Counter at 0. Knit to Row 94 (98) [102]. ON EACH SIDE, remove 13 sts. onto contrast waste yarn. Continue in Stockinette stitch WITH CABLES ON EACH SIDE (SEE SPECIAL INSTRUCTIONS FOR CABLES. After Row 158 (166) [174], remove the neck and each shoulder separately onto contrast waste yarn.

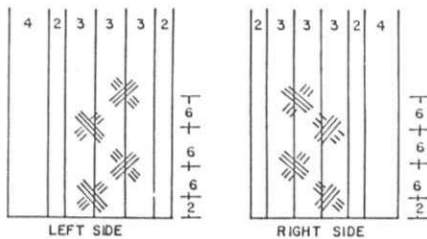

SPECIAL CABLE INSTRUCTIONS.
After the ARMHOLE bind offs, Knit 2 rows, then begin the CABLES on each side as shown on the Charts.

First*cross the OUTSIDE 3 + 3 sts. outside 3 sts. with INSIDE 3 sts. ON TOP. Knit 6 rows. Cross the INSIDE 3 + 3 sts. with the INSIDE 3 on TOP. Knit 6 rows. REPEAT FROM * and REMEMBER, to RAVEL the 2 sts. on each side of cables (SEE CHART) ONE STITCH AT A TIME and latch them up into knit sts. Latch the sts. up between the Cables - approximately every 10 or 14 rows.

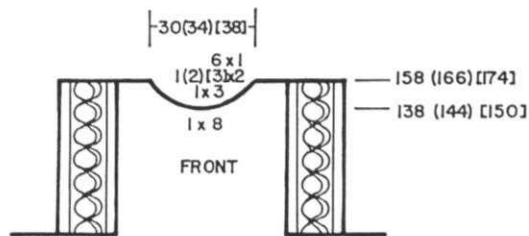

FRONT:

Work the front the same as the back to front neck shaping. After Row 138 (144) [150], bind off (or remove onto waste yarn) the center 8 sts. Put the needles on the left side into holding position and complete the right side first.

* ON NECK SIDE, bind off (or work short rows) 3 sts. 1x, 2 sts. 1x (2x) [3x], the 1 st. 6x. After Row 158 (166) [174], remove the remaining sts. onto waste yarn. Transfer carriage from right to left side. Bring the needles on the left side into working position. Turn Row Counter to 138 (144) [150] and complete the left half. Follow the instructions from *.

SLEEVES:

Cast on 41 (43) [45] sts. and work 20 rows K1, P1 Ribbing. Transfer the ribber sts. to main machine, knit 2 rows Stockinette stitch then remove the sts. onto contrast waste yarn. Hang the sts. back onto the machine increasing to 44 (48) [52] sts. Counter at 0. Work Stockinette stitch. ON EACH SIDE, increase 1 st. every 5th row 23x (24x) [25x]. After Row 120 (128) [136], mark each side with a bit of waste yarn. Knit to Row 138 (146) [154]. Mark center st. with bit of yarn then remove the sts. onto contrast waste yarn.

FINISHING:

Close shoulders first, then hang open sts. of sleeve with right side facing you onto 90 (96) [102] needles. With wrong side facing you, pick up sts. along armhole, knit 1 row then bind off loosely. Weave the OPEN sts. of armhole to marked row on sleeve. Work 1 row single crochet around neckline from the right side.

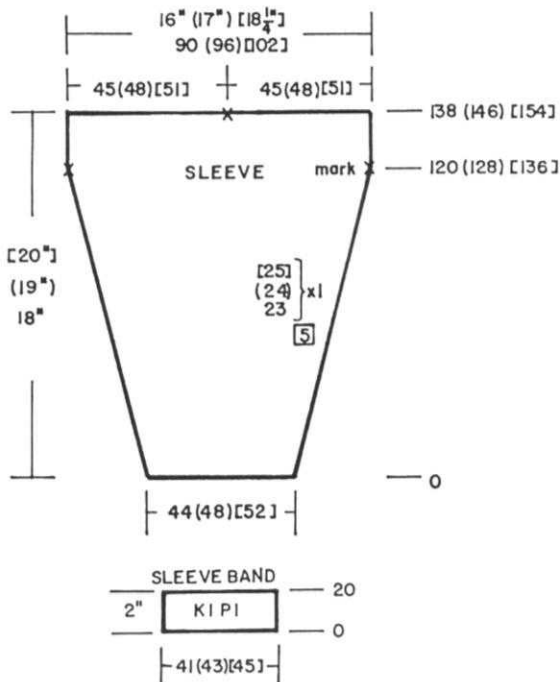

Let's start
MACHINE KNITTING

LETS START MACHINE KNITTING....

This is the book we have all been waiting for.. A step by step volume of instructions... profusely illustrated with hundreds of line drawings, caricatures of people mouthing instructions and humorous comments.. It's a large book 8-3/4 x 11-3/4" and 158 pages... packed full of good easy to understand information embracing practically everything one needs to know about knitting, blocking, finishing, etc... It's so complete it even tells you when to take a coffee break! Six full size Knitleader sheets are included with instructions for twelve garments....All illustrated in full color...

It's the best practical machine knitting instruction book yet and it's excellent for all Japanese made knitting machines.

Order from your local dealer or direct from KNITKING at 1128 Crenshaw Blvd., Los Angeles , California 90019.





WOMENS TWO-PIECE DRESS

SIZES: 6/8 (10/10) [14/16]

YARN: Venetia

AMOUNT:

color 1 1 1/2 1 1/2 2 lbs.

color 2 3 oz. for all sizes.

TENSION: 4 RIB. 4/3/II

GAUGE: 16 sts. 26 rows = 2" (5 cm)

TOP is Stockinette stitch with full needle ribbing at lower edge. Sleeve trim is combination of full needle rib and lace.

SKIRT: Lower section is knitted sideways on the machine in combination of stockinette and lace. Upper section of skirt is also stockinette and lace.

TOP BACK:

BEGIN WITH FULL NEEDLE RIBBING. Cast on 150 (162) [174] sts. with color 1 and work 14 rows full Needle Ribbing.

Transfer the ribber sts. to main machine and increase 1 st. on EACH SIDE.

Continue in Stockinette stitch. After Row 54, ON EACH SIDE, decrease 1 st. every 4th row 4x, knit 4 rows, the ON EACH SIDE, increase 1 st. every 4th row 4x.

After Row 170 (180) [190], ON EACH SIDE, cast on 2 sts. 2x. Knit to Row 268 (282) [296]. Bind off the center 20 (24) [28] sts. put the needles on the left into holding position and complete the right side first.

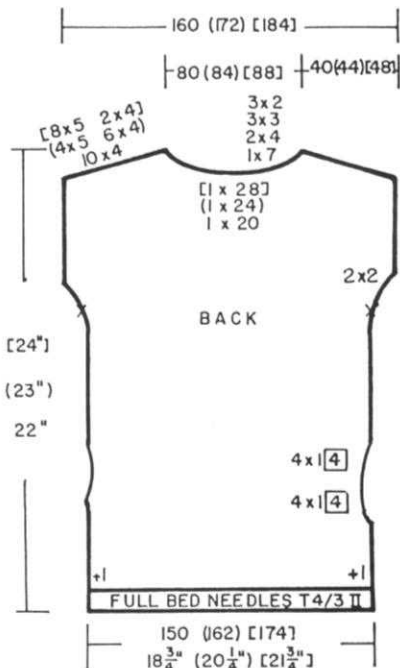

[24"]
[23"]
22"

— 288 (302) [316]
— 268 (282) [296]

— 174 (184) [194]
— 170 (180) [190]

— 82

— 54

— 14

— 0

*SHAPE SHOULDER AND NECK AT THE SAME TIME.
FOR SHOULDER, bind off 4 sts. 10x (5 sts. 4x, 4 sts. 6x) [5 sts. 8x, 4 sts. 2x]
FOR NECK, bind off 7 sts. 1x, 4 sts. 2x, 3 sts. 3x, 2 sts. 3x.
Bring the needles on the left into working position, knit 1 row to the left, turn the Row Counter back to 268 (282) [296] and complete the left half. Follow the instructions from *.

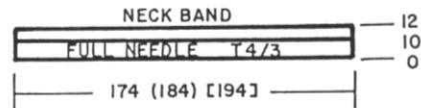

NECKBAND: FULL NEEDLE RIBBING.

Close 1 shoulder first. With color 1, cast on 174 (184) [194] and work full needle ribbing to Row 10. Transfer the ribber sts. to main machine. With wrong side facing you, pick up from shoulder 76 (82) [90] sts. across the back neck, then the remaining sts. across the front. Knit 1 loose row then bind off.

SLEEVE BANDS. FULL NEEDLE RIBBING WITH LACE. READ SPECIAL LACE INSTRUCTIONS FIRST.

With color 1, cast on 102 (110) [118] sts. Work FULL NEEDLE RIBBING to Row 10.

Transfer the ribber sts. to main machine. Knit 2 rows. Work the SPECIAL INSTRUCTIONS FOR LACE to Row 16.

With color 1, work in Stockinette stitch to Row 20.

With wrong side facing you, pick up the stitches around armhole and hang onto machine. Knit 1 row then bind off LOOSELY.

FINISHING: See General Instructions.

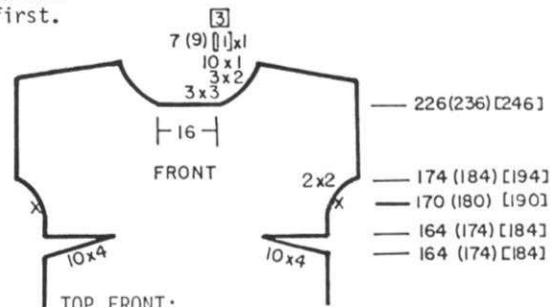

TOP FRONT:

Work the front the same as the back to Row 164 (174) [184]. WORK SHORT ROWS FOR BUST DARTS AND DO NOT COUNT THESE ROWS. ON OPPOSITE SIDE OF CARRIAGE, BRING INTO HOLDING POSITION, 4 sts. 10x ON EACH SIDE. ON OPP. SIDE OF CARRIAGE, bring all the needles back into working position before knitting the next 2 rows.

After Row 170 (180) [190], ON EACH SIDE, cast on 2 sts. 2x. Knit to Row 226 (236) [246]. Bind off the center 16 sts., put the needles on the left into holding position and complete the right side first.

*ON NECK SIDE, bind off 3 sts. 3x, 2 sts. 3x, 1 st. 10x, then 1 st. every 3rd row 7x (9x) [11x] BUT AT THE SAME TIME, After Row 268 (282) [296], SHAPE SHOULDER SAME AS THE BACK.

Bring the needles on the left into working position, knit 1 row to the left side, turn the Row Counter back to 226 (236) [246] and complete the left half. Follow the instructions from *.

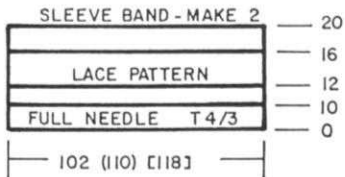

IMPORTANT INSTRUCTIONS FOR LACE STRIPES.

With color 1, knit to the eyelet row.
*MAKE EYELETS ACROSS then change to color 2.
Knit 2 rows.
REPEAT FROM * 1 time MORE.
MAKE EYELETS ACROSS.
Change to color 1 and continue.

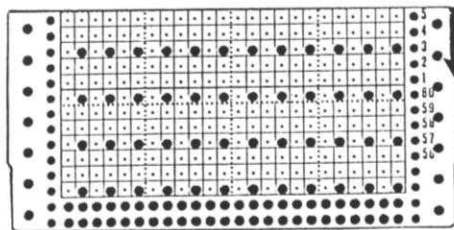

REPEAT the Punch Card through Row 53, then punch 2 rows of holes for connecting Card.

CONTINUED

LOWER SKIRT FOR FRONT AND BACK:

OPEN CAST ON WITH WASTE YARN
96 (100) [104] sts.
After knitting 9 to 11 rows,
knit 1 row with Ravel Cord to
the right side.
Counter at 0, change to color 1.
Knit to Row 4.
*WORK SHORT ROWS:
ON OPPOSITE SIDE OF CARRIAGE,
bring 70 needles into holding
position. Knit 2 rows.
ON OPPOSITE SIDE OF CARRIAGE,
bring back into working position,
20 sts. 3x. (10 sts.
remain).
OVER ALL NEEDLES, knit 5 rows.
Increase 1 st. on the LEFT.
Knit 5 rows.
WORK THE SPECIAL LACE INSTRUCTIONS.
Knit 4 (5) [6] rows.
Increase 1 st. on the LEFT.
Knit 4, (5) [6] rows.
WORK SHORT ROWS: ON OPPOSITE
SIDE OF CARRIAGE, bring into
holding position,
10 sts. 1x, 20 sts. 3x.
Push all the needles to working
position and knit 5 rows.
Increase 1 st. on the LEFT.
Knit 5 rows.
REPEAT FROM * 8 times MORE,
THEN REPEAT FROM * 9 times
more BUT DECREASE 1 st. on
the LEFT EACH TIME instead of
increasing (see Chart) and
END WITH KNITTING 5 rows
instead of 10 rows.
Remove onto contrast waste
yarn.

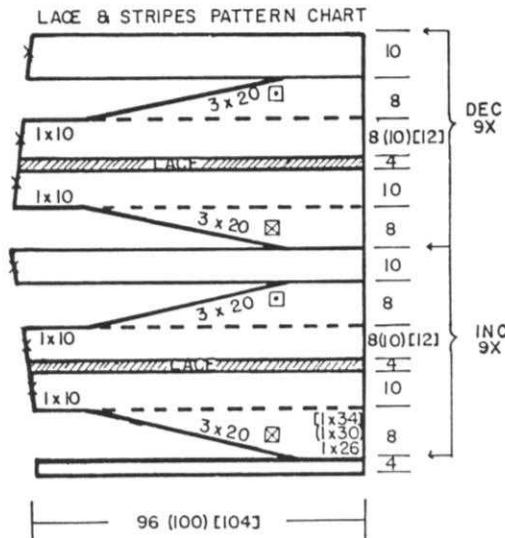

UPPER SKIRT - BACK & FRONT THE SAME.

OPEN CAST ON with waste yarn.
156 (170)[184] sts. After 9 to 11
rows of waste knitting, knit 1 row
with Ravel Cord to the left side.
Change to color 1 and put Counter at
0. Knit 4 rows.
KNIT THE SPECIAL LACE INSTRUCTIONS.
Knit 2 rows. WORK SHORT ROWS.
Bring all the needles into holding
position
ON OPPOSITE SIDE OF CARRIAGE,
Push back into working position,
6 sts. 26x
(3 sts. 3x, 7 sts. 23x)
[7 sts. 24x, 8 sts. 2x].
After Row 62, ON EACH SIDE,
decrease 1 st. every 9th (10th)
[11th] row 9x.
After Row 144 (154) [164], remove
the sts. onto contrast waste yarn.
WORK THE 2ND SECTION WITH THE
SHORT ROWS BEGINNING ON THE LEFT
SIDE (reverse shaping).

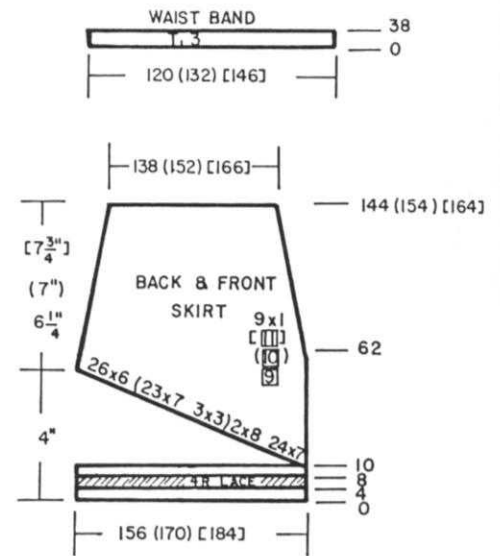

WAISTBAND: Make 2.

With color 1, cast on 120 (132)
[146] sts. and work Stockinette
stitch with Tension 3.
Knit to Row 38. Pick up the cast
on sts. to form hem.
With wrong side facing you, pick
up the open sts. of waist and
hang onto these needles, decreasing
evenly across.
Knit 1 row then bind off LOOSELY.

FINISHING:

Weave the open sts. of lower skirt
together first. Close side seams
of upper skirt. Pin the SHORT SIDE
of LOWER SKIRT to LONG side of
upper skirt matching woven seam to
upper seam. Fold in half and pin
long fold of lower skirt to short
seam of upper skirt.
ON THE WRONG SIDE, slip stitch crochet
the two sections together smoothly.
Insert elastic through waistband then
close band.



MENS ZIPPERED JACKET

SIZES: 40/42 (44/46)
YARN: Extra
AMOUNT:
color 1 8 8 balls
color 2 2 2 balls
color 3 2 2 balls
TENSION: 4.75 1 Rib 0/0 II
GAUGE: 9.5 sts, 14.5 rows = 2" (5 cm)
22" Jacket type zipper 7.25

Can be knitted on any BULKY machine
with Ribber.
Stockinette stitch and Short Rows
changing colors as shown on Chart
and in instructions. Bands are
K1, P1 Ribbing.

BACK:

With color 1, cast on 101 (109) sts.
and work 24 rows K1, P1 Ribbing.
Transfer the ribber sts. to main
machine and increase 1 st. on the
right edge.
ALWAYS WORK THE DECREASE SHORT ROWS
FIRST - so ON EACH SIDE, put
10 (12) sts. into holding position.
Set Carriage for holding position.
Attach color 1 to right edge of
the 82 (86) sts. in work, then with
color 1, work the holding short
rows as follows:
ON OPPOSITE SIDE OF CARRIAGE, put
1 needle into holding position
40 (42) times ON EACH SIDE and be
sure to wrap the inside needle
around holding around holding needle
to prevent a hole. Cut yarn.
Leave the center 82 (86) plus the
10 (12) sts. on the left side in
holding position.
Bring 10 (12) needles on the right
side into working position and
attach color 2. Put Counter Back to
24. Bring back into working position
1 sts. 41x (43x).

Work HOLDING POSITION SHORT ROWS
1 st. 36x (38x) BUT AT THE SAME
TIME, SHAPE ARMHOLE after Row
110 (114).
Bind off 4 sts. 1 x, then full fashion
decreases 2 sts every 4th row 2x.
Continue the short row decreases
to Row 180 (188). Bind off 7 (9)
shoulder stitches.
Bring the carriage to the left side,
turn the Row Counter back to 24 and
with color 3, work the same short
rows as you did on the right side
and don't forget to shape armhold
after Row 110 (114).
When this side is completed, put
the center 2 sts. into working position,
turn Counter to 108 (114).
With color 1, work the INCREASE
SHORT ROWS - 1 st. 35x (37x) ON
EACH SIDE (See Chart).
SHAPE SHOULDER: ON EACH SIDE
bind off 5 sts. 2x, 6 sts. 2x.
Bind off the remaining sts. loosely
or you can remove the neck sts onto
waste yarn.

LEFT FRONT:

With color 1, cast on 51 (55) sts. and work 24 rows k1, P1 Ribbing. Transfer the ribber sts. to main machine and increase 1 st. on the left side.

Put 10 (12) sts. on the LEFT SIDE into holding position and work the DECREASE SHORT ROWS over the right 42 (44) sts. with color 1, same as you did for the back. (See Chart). Bring the 10 (12) sts. on the left into working position, attach color 2 and work the INCREASE SHORT ROWS THEN DECREASE SHORT ROWS BUT AT THE SAME TIME, after Row 110 (114) SHAPE ARMHOLE same as you did for the back. After Row 180 (188) bind off the 7 (9) shoulder sts.

Attach color 1 on the right side and work the INCREASE SHORT ROWS (See Chart). BUT AT THE SAME TIME, AFTER Row 164 (170) SHAPE NECK: Bind off 6 sts. 1x, 3 sts. 1x, 2 sts. 1x, 1 st. 3x (5x). After Row 181 (189) make the shoulder bind offs same as the back.

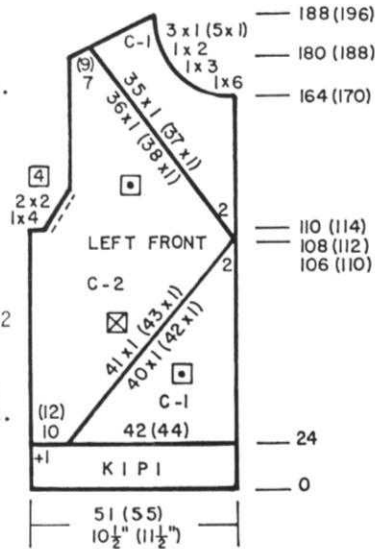

RIGHT FRONT:

Work the right front the same as the left side, but change colors as shown on the Chart and after the ribbing, increase 1 st. on the right side, knit 1 row to the left side and turn the Row Counter to 24, to make it easy for you to follow the left side instructions.

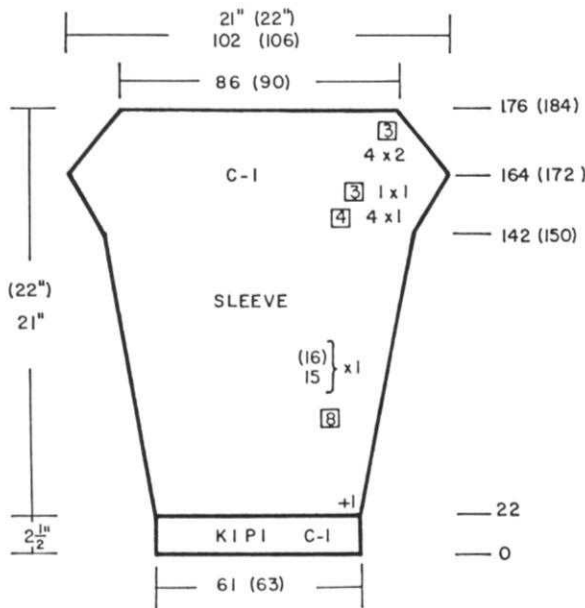
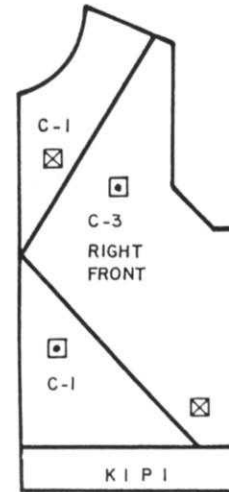

SLEEVES:

MAKE ALL INCREASES AND DECREASES USING THE FULL FASHION METHOD. With color 1, cast on 61 (63) sts. and work 22 rows K1, P1 Ribbing. Transfer the ribber sts. to main machine. Increase 1 st. on the right side. Continue knitting in Stockinette stitch. ON EACH SIDE, increase 1 st. every 8th row 15x (16x). After 142 (150) ON EACH SIDE, Increase 1 st. every 4th row 4x, then 1 st. every 3 row 1x. After Row 164 (172) ON EACH SIDE, decrease 2 sts. every 3rd row 4x. After Row 176 (184), remove the sts. onto contrast waste yarn.

BACK

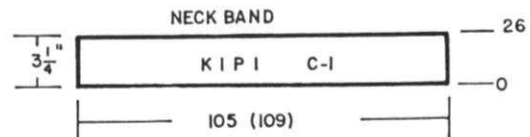
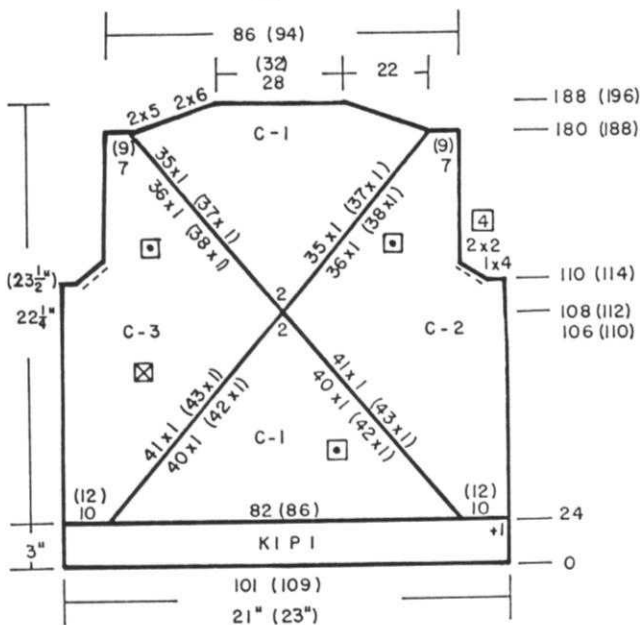

NECKBAND:

With color 1, cast on 105 (109) sts. and work 26 rows K1, P1 Ribbing. Transfer the ribber sts. to main machine then pick up the cast on sts. to form a hem. Knit 1 row over the doubled sts. then remove them onto contrast waste yarn.

FINISHING:

See General Instructions. Weave the open sts. of sleeves into armhole. Slip stitch the open sts. of neckband to neckline. ON THE RIGHT SIDE OF KNITTING, single crochet along both front edges, including neckband. Sew in jacket type (separating) zipper by hand beginning at lower edge up to the bottom of neckband.



MENS RIBBED PULLOVER

SIZES: 38/40 (42/44)
YARN: Regia 3-ply
AMOUNT: 9 10 balls
TENSION: 6/6 I
GAUGE: 16 sts. 21 rows = 2" (5 cm)

A Ribbing Pattern of Knit 5, Pur1 2.
 Bands are full needle ribbing.

BACK:

SEE SPECIAL INSTRUCTIONS FOR CAST ON AND PATTERN.
 Cast on 167 (179) as follows:
 83 (89) sts. to the left of 0 and 84 (90) to the right of 0.
 Knit in Pattern to Row 138 (148).
SHAPE RAGLAN ON EACH SIDE:
 Decrease 2 sts. every 2nd row 7x (9x) then 2 sts. every 4th row 23x (24x) and make the decreases as follows: From the edge, transfer 5 and 6 over to 7 and 8, move the sts. in to fill empty needles.
 When a Ribber needle is involved, transfer the stitch to main machine FIRST, then make the full fashion decrease.
 After Row 246 (264) transfer all ribber sts. to main machine.
 Knit 1 row Stockinette stitch then remove the sts. onto contrast waste yarn.

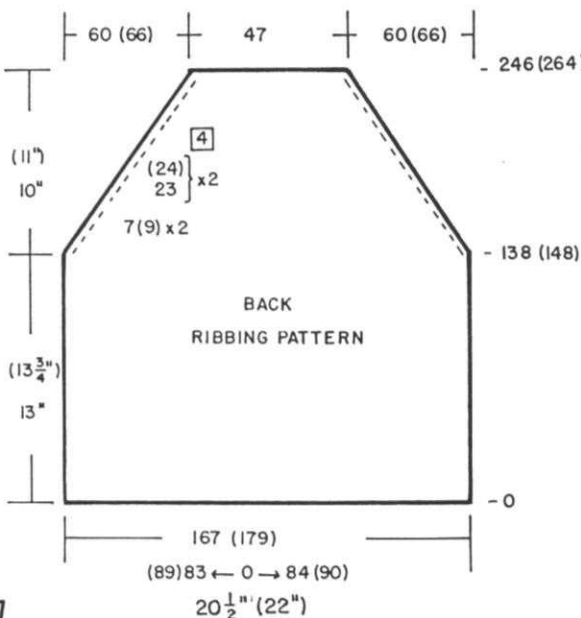

IMPORTANT: SPECIAL RIBBING PATTERN INSTRUCTIONS

The cast-on for body of garment and the sleeves is a special technique and you must follow these instructions.
 ON THE MAIN BED ONLY, cast on with contrast waste yarn. Knit at least 4" of stockinette stitch ending with 1 row Ravel cord to the right side. NOW HANG PLENTY OF WEIGHTS. Change to garment yarn and knit 2 rows Stockinette stitch.
CONNECT RIBBER with ribber Carriage. Now make transfers to the Ribber as follows. FOLLOW the Line Drawing for needle set up but transfer the sts. as follows. Leave Ribber Pitch on P for now. Transfer the first needle to the right of 0 to the adjacent Ribber needle, then PUT THE EMPTY MACHINE NEEDLE OUT OF WORK. To the RIGHT of 0 on main machine, with double eyed transfer tool, pick up the cross thread below this stitch and place it onto adjacent ribber needle. IT IS IMPORTANT THAT THE STITCH REMAINS ON MAIN MACHINE AND YOU HAVE MADE A NEW STITCH TO PLACE ON THE RIBBER. Only 1 needle is out of work on the main machine. MAKE ALL THE TRANSFERS ON EACH SIDE AS SHOWN ON THE LINE DRAWING in this way. When this is completed, MOVE RIBBER PITCH TO H (half pitch).

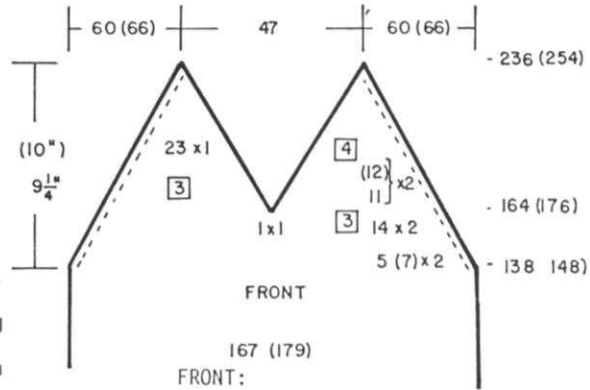

Work the front the same as the back to Row 138 (148).
FULL FASHION DECREASES using the same method as for back. ON EACH SIDE, decrease 2 sts. every 2nd row 5x (7x), 2 sts. every 3rd row 14x, 2 sts. every 4th row 11x (12x) BUT AT THE SAME TIME, after Row 164 (176), **SHAPE NECK:** Transfer the first Ribber stitch on right of 0 to neighboring needle. Put the empty needle out of work. Put all the stitches on the LEFT SIDE INTO HOLDING POSITION. Be sure to set both main machine and Ribber Carriages to hold needles. Work the RIGHT SIDE FIRST.

*ON NECK SIDE, work the decreases on the edge. Decrease 1 st. every 3rd row 23x. **RELEASE HOLDING CAMS ON BOTH CARRIAGES.** Knit 1 row to the left, SLOWLY, turn the Row Counter back to 164 (176) and complete the left half. Follow the instruction from * and don't forget to complete the ARMHOLE SHAPING.

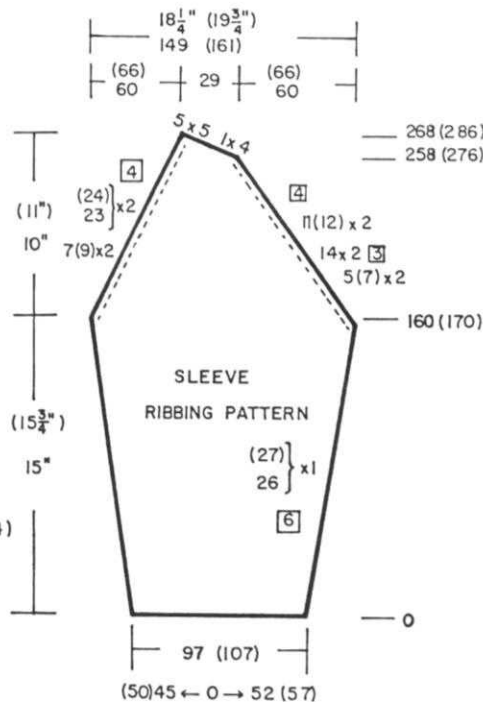

SLEEVES:
IMPORTANT: When making increases on each side, make them on the main machine FIRST. When you have 8 sts. lined up on the main machine, SET INTO PATTERN AND BE SURE TO USE WIRE LOOP TYPE WEIGHT HANGERS ON EACH EDGE TO PREVENT DROPPED STITCHES AND MOVE THEM UP EACH TIME AS EACH NEW PATTERN IS FORMED. Cast on with waste yarn same as you did before using needles 45 (50) to the LEFT of 0 and 52 (57) to the RIGHT of 0. Continue in Pattern. ON EACH SIDE, increase 1 st. every 6th row 26x (27x). After Row 160 (170), **SHAPE RAGLAN:** Use the same method as you did before and follow the CHART FOR THE DIFFERENT DECREASES ON EACH SIDE. After Row 259 (277), work **SHORT ROWS.** When pattern is involved, transfer the ribber sts. to the main machine first. ON OPPOSITE SIDE OF CARRIAGE, 4 sts. 1x, 5 sts. 5x. When completed, all sts. should be on the main machine. Knit 1 row then remove onto contrast waste yarn. Make 2nd sleeve and REVERSE THE SHAPING.

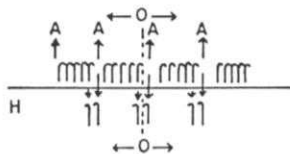

WAISTBAND: Make 2.

FULL NEEDLE RIBBING: Cast on 88 (94) sts. Tension 4/3 I. Knit to Row 46. Transfer the ribber sts. to main machine. Pick up the open sts. of front or back and hang onto these needles, decreasing evenly across - approximately 2 sts. on each needle. Knit 1 row then bind off loosely.

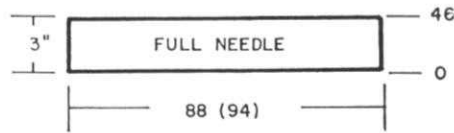

SLEEVE BANDS: Make 2.

FULL NEEDLE RIBBING: Cast on 51 (56) sts. Tension 3/2 I. Knit to Row 40. Transfer the ribber sts. to main machine. Pick up the open sts. of sleeve and hang onto these needles, decreasing evenly across - approximately 2 sts. on each needle. Knit 1 row then bind off loosely.

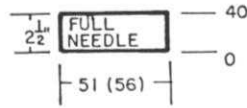

FINISHING: See General instructions. Fold neckband in half to the inside and sew in place and weave the front seam.

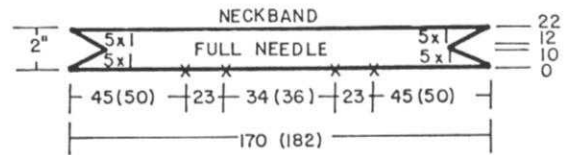

NECKBAND: SET IN SLEEVES FIRST.

FULL NEEDLE RIBBING. Cast on 170 (182) sts. Tension 5/4 I. ON EACH SIDE, decrease 1 st. every 2nd row 5x. After Row 12, ON EACH SIDE, increase 1 st. every 2nd row 5x. After Row 22, transfer the ribber sts. to main machine. With wrong side facing you, pick up sts. around neckline as follows. 45 (50) sts. for front neck, 23 sts. for sleeve, 34 (36) sts. for back neck, 23 sts. for sleeve, 45 (50) sts. for front neck. Knit 1 row then bind off loosely.



WOMENS VEST AND SKIRT

SIZES: 10/14 (16/18)

YARN: Venetia

AMOUNT:

- color 1 6 oz. 8 oz.
- color 2 4 oz. 6 oz.
- color 3 4 oz. 6 oz.
- color 4 4 oz. 6 oz.

TENSION: WITH RIBBER 5/4.2 II
GAUGE: 15 sts. 40 rows = 2" (5 cm)

Use Ribber Color Changer and any standard machine. Fair Isle Pattern with 4 colors in one row. Full needle ribbing throughout.

USE STYLE NO. 505 FOR SKIRT
PATTERN FOUND IN THIS ISSUE.

SPECIAL KNITTING INSTRUCTIONS. You can knit this Vest on a Standard Punch Card machine as well as the Electronic. Simply punch card as shown on drawing for Electronic. Carriage on the RIGHT. Select needles for pattern right to left.

Push in BOTH SKIP BUTTONS on main machine.

* Color 1, knit 2 rows.
Change to color 2, knit 2 rows.
Change to color 3, knit 2 rows.
Change to color 4, knit 2 rows.
REPEAT FROM * FOR PATTERN.

BACK: SEE CHART FOR PROGRAMMING.

With color 1, cast on FULL NEEDLE RIBBING, 162 (186) sts. Knit 2 rows Ten. 1/1 II. Knit 2 rows Ten. 2/2 II. Knit 2 rows Ten. 3/3 II. Carriage is on the RIGHT. CONTINUE WITH SPECIAL PATTERN INSTRUCTIONS.

After Row 290 (328), SHAPE ARMHOLE: ON EACH SIDE, bind off 5 sts 1x, 3 sts. 1x, 1 st. 4x.

After Row 510 (566) transfer the ribber sts. to main machine putting the original sts. behind the latches and the ribber sts. in the needle hooks. Pull the front stitches through the back sts.

Remove the neck and each shoulder sts. separately onto waste yarn.

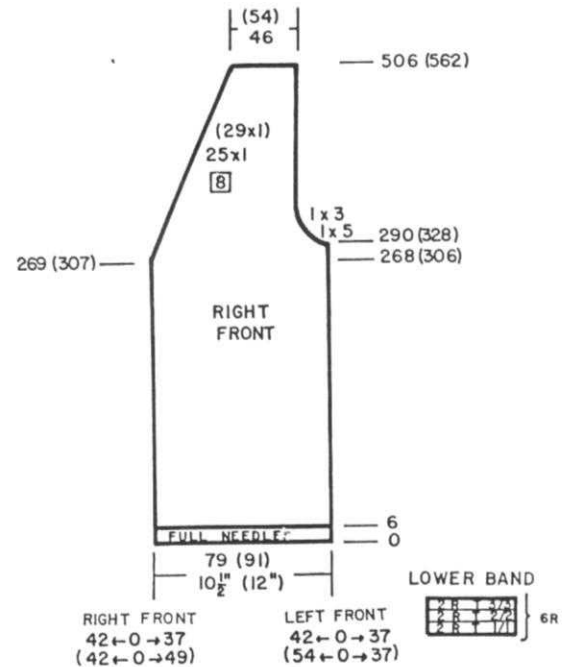

RIGHT FRONT: SEE CHART FOR PROGRAMMING.

FULL NEEDLE RIBBING:

Cast on over needles to 42 (42) on the left of 0 and 37 (49) to the right of 0. Bring to work the appropriate ribber needles. 79 (91) sts. Knit the 6 rows with Tension changes same as the back. Continue in Pattern same as the back. After Row 269 (307) SHAPE FRONT NECK. Decrease 1 st. every 8th row 25x (29x) BUT AT THE SAME TIME, after Row 290 (328) SHAPE ARMHOLE: Bind off 5 sts. 1x, 3 sts. 1x. After Row 506 (562) transfer the ribber sts. same way as you did for back, then remove onto waste yarn.

LEFT FRONT: SEE CHART FOR PROGRAMMING.

Work the left front the same as the right front with the exception of casting on.

Cast on over needles 42 (54) on the LEFT OF 0, and 37 (37) to the RIGHT OF 0.

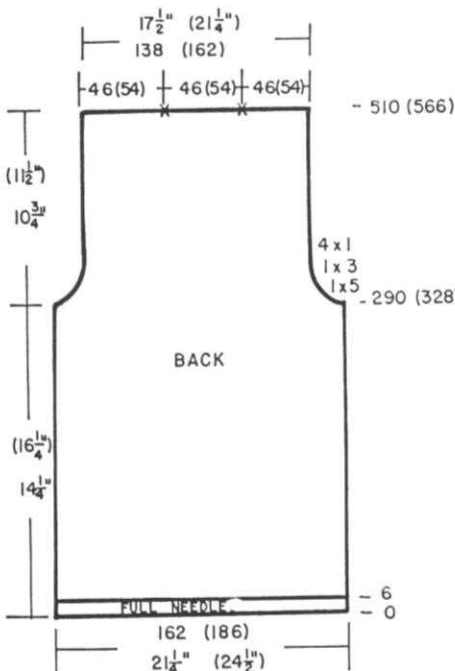

CONTINUED

SLEEVE BANDS: Make 2.

Slip stitch crochet the open sts. of shoulders together or you can hang them onto machine and bind off. FULL NEEDLE RIBBING with color 1. Cast on 160 (180) sts. and work ribbing, 4 rows Tension 0/0, 2 rows Tension 1/1, 2 rows Tension 2/1.2, 2 rows 3/2.2. Transfer the ribber sts. to main machine, then hang the armhole onto these needles. Knit 1 row then bind off loosely.

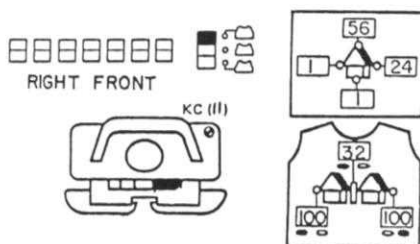
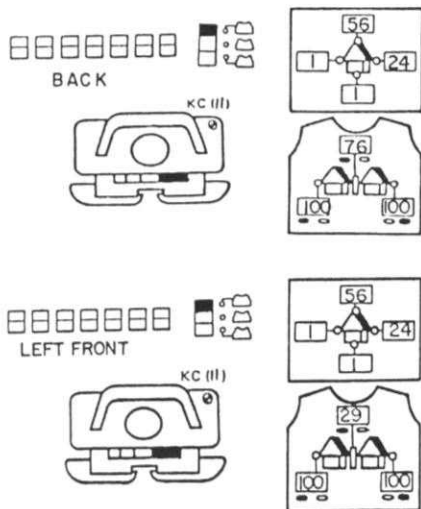
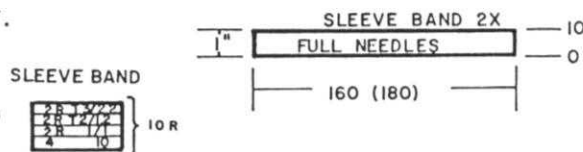

FINISHING:

See General Instructions. With double strand of color 1, work single crochet around neck and down fronts then work 1 row reverse single crochet. (USE CROCHET HOOK NO. 1 or 2). If you want to have a reversible Vest, you can hang the side edges back onto machine with right sides together. Knit 6 rows Stockinette stitch with color 1 then bind off. Fold over and sew down flat.

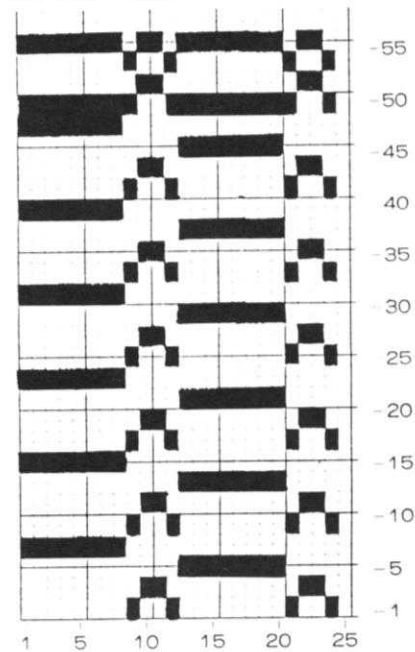

WOMENS DRESS

SIZES: 8/10 (12/14)
YARN: Venetia
AMOUNT: 2 lbs. for all sizes.
TENSION: 4.1 Rib. 4.1/3.1 II
GAUGE: 15 sts. 25 rows = 2" (5 cm)

Knitted on the KH 910 and can be knitted on any Punch Card Machine with Lace Carriage. If you own other than KNITKING or Brother machine, use any similar lace pattern that can be made on your brand of machine. Lower hem is full needle ribbing.

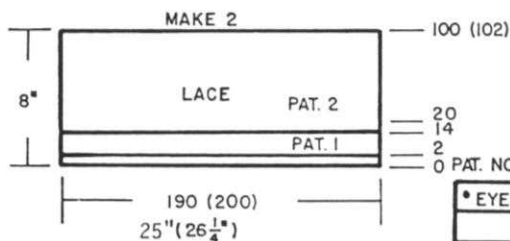
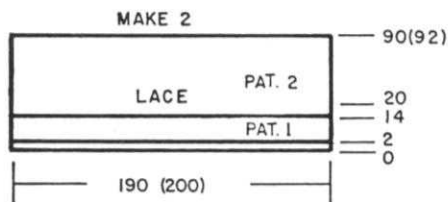
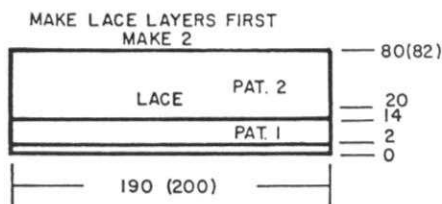
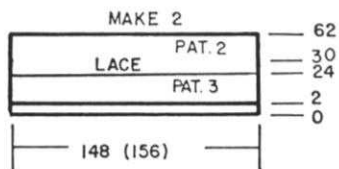

TIERS for SKIRT:

Make the TIERS for Skirt section FIRST.
1. Cast on 190 (200) sts. with contrast waste yarn. Work about 2" of waste knitting then 1 row with Ravel Cord to the right side. Bring the needles to 'E' position (holding) and LATCH TOOL CAST ON with garment yarn. Counter at 0. Knit 2 rows. Work LACE PATTERN 1 to Row 14. Knit to Row 20. Work LACE PATTERN 2 to Row 100 (102). Remove onto contrast waste yarn. MAKE 2. Make Tier 2 in the same way with same number of sts. but knit to Row 90 (92) and remove onto waste yarn. MAKE 2. Make Tier 3 in the same way, same number of sts. but knit to Row 80 (82) and remove onto waste yarn. MAKE 2.

COLLAR: Make 2

Begin with contrast waste yarn and ravel cord same as you did for the Tiers. Latch Tool cast on in the same way. 148 (156) sts. Counter at 0. Knit 2 rows then work PATTERN 3 to Row 24, then knit to Row 30. Work PATTERN 2 to Row 62. Remove onto contrast waste yarn

DRESS (BACK & FRONT THE SAME).

SECTION A:

BEGIN WITH FULL NEEDLE RIBBING. Cast on 148 (158) sts. and work 14 rows full needle ribbing. Transfer the ribber sts. to main machine and continue in Stockinette stitch to Row 90 (92). Remove the sts. onto contrast waste yarn.

Bring 148 (158) needles into working position and with WRONG side facing you, hang the open sts. of TIER 1 onto these needles. If you bring the 3rd and then next 4th and ALTERNATE 3rd and then 4th needles to D position across, it will make it easy for you to hang 2 sts. on each of these marked needles as you pick up the sts. from waste yarn. Hang the open sts. of SECTION A onto these same needles with wrong side facing you. Counter at 90 (92). Continue in Stockinette stitch for section B to Row 170 (174).

sts. onto contrast waste yarn. Hang the sts. from TIER 2 onto the needles same as you did before then Section B in the same way. Knit to Row 240 (246). Remove onto waste yarn again.

Pick up sts. from TIER 3 same as before then pick up SECTION C. Counter at 240 (246). Knit Stockinette stitch to Row 248 (254).

BEGIN LACE PATTERN 2.

ON EACH SIDE, after Row 286 (290) decrease 1 st. every 10th row 2x. After Row 306 (310) ON EACH SIDE, increase 1 st. every 10th row 2x.. After Row 388 (398), SHAPE

ARMHOLE:

ON EACH SIDE, bind off 5 (6) sts. 1x, 4 (5) sts. 1x, 4 sts. 1x, 3 sts. 1x, 2 sts. 1x, 1 st. 5x.

After Row 460 (474), bind off the center 54 (58) sts. Put the needles on the left into holding (A) position and complete the right side first.

* ON NECK SIDE, decrease 1 st. 10x and after Row 476 (488) FOR SHOULDER bind off 5 sts. 2x, 4 sts. 1x (4 sts. 3x, 3 sts. 1x).

Bring the needles on the left into working position and complete the left half. Follow the instructions from *.

FINISHING:

Close 1 shoulder first.

With wrong side facing you, pick up the open sts. of both sections of Collar and hang onto machine DOUBLING the sts.

With wrong side facing you, Pick up sts. across front and back of neck, front neck covering 1 section of collar and neck the other section. Seams should be at shoulder line. Knit 10 rows Stockinette stitch, hang the hem then bind off LOOSELY. Close shoulder and weave collar seams. Close sides of dress and Tiers separately.

Work single crochet around armholes.

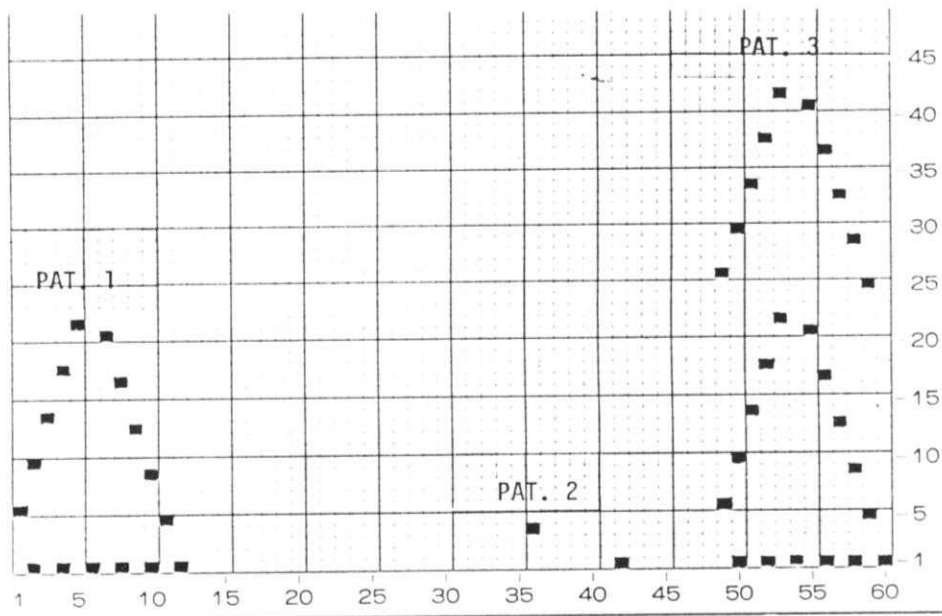
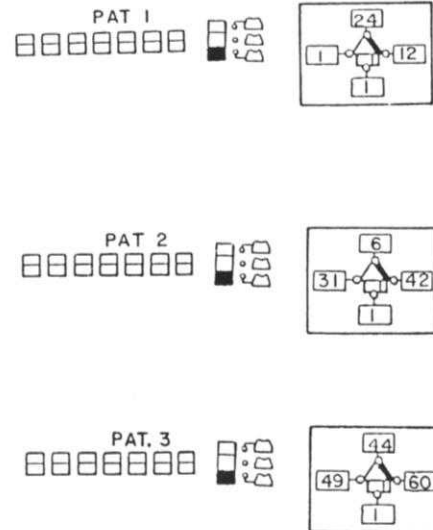
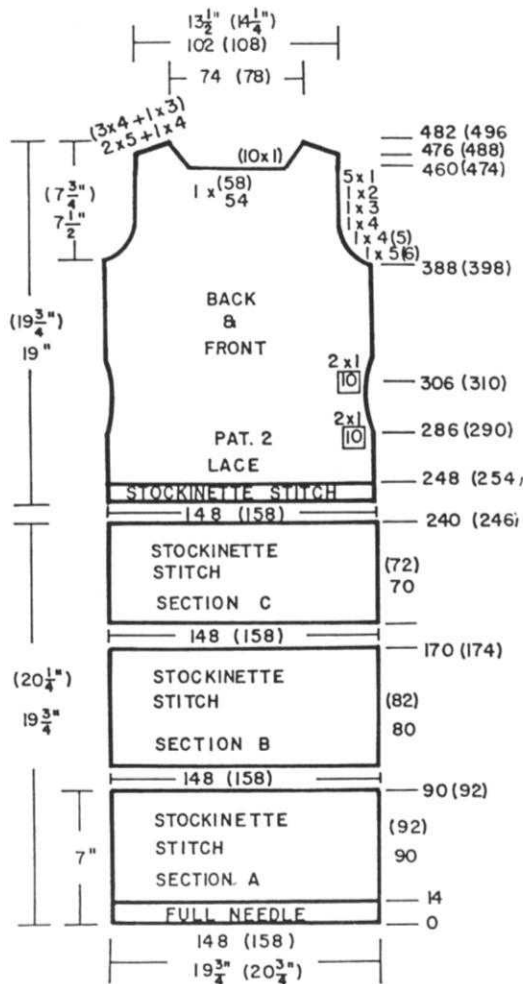



WOMENS DRESS

SIZES: 6/8 (10/12) [14/16]
 YARN: Venetia and Fantacia
 color 1 2 lbs. (all sizes) Venetia
 color 2 1 cone " " Fantacia
 TENSION: 4.2 Stockinette st.
 4 Lace
 GAUGE: Stock. 16 sts. 24 rows = 2"
 Lace 15 sts. 23 rows = 2"

Stockinette stitch with stripes of Fantacia and a Lace Pattern. Punch Card.

SKIRT: Make 6 sections the same.

OPEN CAST ON WITH WASTE YARN AS FOLLOWS:

TO THE LEFT OF 0, bring 41 (44) [42] needles into work (B) position and to the RIGHT OF 0, bring 31 (33) [43] needles to working position. Cast on over these needles with your waste yarn. Knit 9 to 11 rows then 1 row with a Ravel Cord to the right side. Counter at 0
 With color 1, knit 4 rows.
 ** With color 2, knit 4 rows.
 Begin Lace Pattern.
 * Knit 2 rows with Color 1.
 Lace Carriage 4x.
 REPEAT FROM * 3x MORE
 Knit 2 rows with color 1. (total 14 rows).
 REPEAT FROM ** 5 times MORE.
 After Row 88, knit 4 rows color 2.
 Continue with color 1 in Stockinette stitch.
 After Row 100, ON EACH SIDE, decrease 1 st. every 20th row 8 x (8x) [9x], then every 10th row 4x (4x) [5x].
 After Row 288 (300) [314], remove the sts. onto contrast waste yarn. MAKE 5 MORE sections the same. Mark center of 2 sections. Sew 3 sections together with the marked section in the center. Sew other 3 sections together in the same way.

UPPER SLEEVE: Make 2.

OPEN CAST ON SAME AS YOU DID BEFORE. Cast on 129 (137) [145] sts. After the waste knitting put counter at 0 and change to color 1.

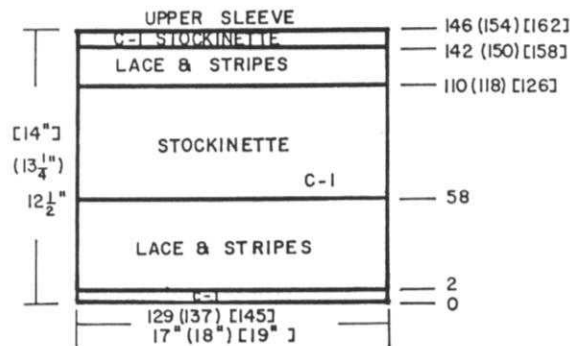
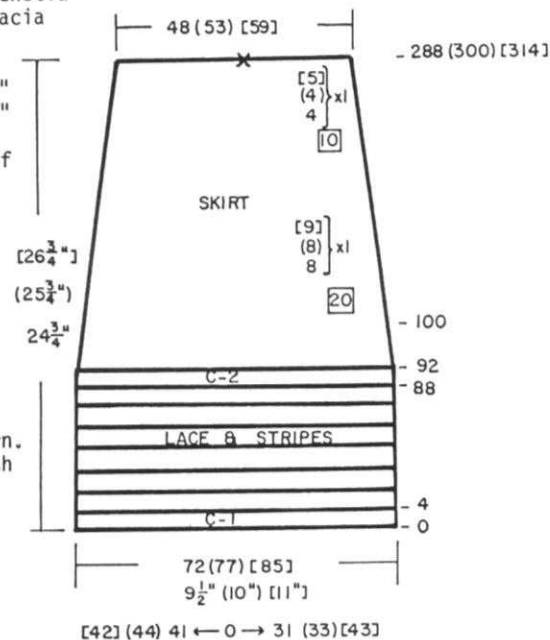
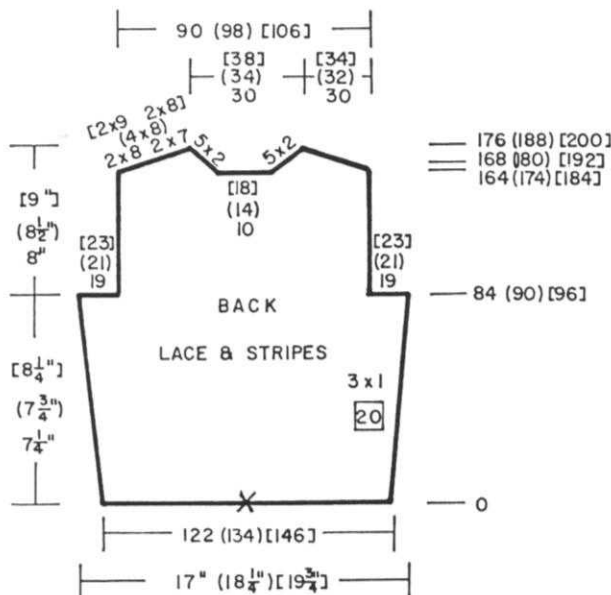

Knit 2 rows, then work LACE PATTERN with stripes same as you did for skirt and bodice to Row 58. Continue in Stockinette stitch with color 1. After Row 110 (118) [126] work Lace and stripes same as before to row 142 (150) [158]. Work stockinette stitch with color 1 to row 146 (154) [162]. Remove onto contrast waste yarn.

BACK BODICE

Make Skirt sections first.

Bring 122 (134) [146] needles to working (B) position. Pick up the open sts. of marked skirt section first, hanging the center onto center 2 needles. Hang the end 2 sts. on each side onto the end 2 needles. Hang the remaining sts. onto machine, doubling evenly across - approxing every 10 or 11th with doubled sts. Counter at 0. Work the LACE PATTERN same as you did for lower edge of skirt. AT THE SAME TIME, increase 1 st. every 20th row 3x ON EACH SIDE. After Row 84 (90) [96], SHAPE ARMHOLE: ON EACH SIDE, bind off 19 (21) [23] sts. Knit to Row 164 (174) [184]. SHAPE NECK: Bind off the center 10 (14) [18] sts. Mark card, then put the needles on the left into holding (A) position using a ravel cord. Complete the right side first. *ON NECK SIDE, bind off 2 sts. 5x AND AT THE SAME TIME, after Row 168 (180) [192], SHAPE SHOULDER: Bind off 8 sts. 2x, 7 sts. 2x (8 sts. 4x) [9 sts. 2x, 8 sts. 2x]. Bring the needles on the left to working position. Turn the Row Counter back to 164 and continue in Lace Pattern from the marked row on Card. FOLLOW THE INSTRUCTIONS FROM *.

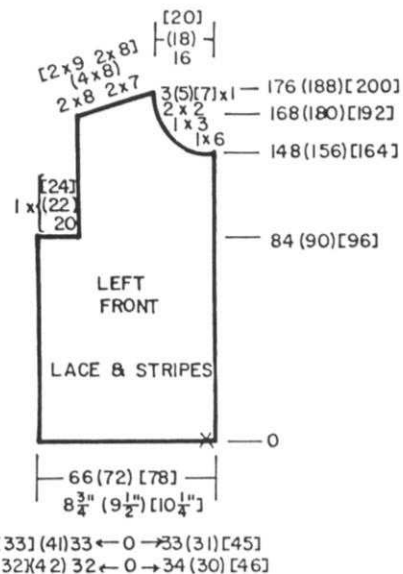

LEFT FRONT BODICE

TO THE LEFT OF 0, bring 33 (41) [33] needles to working position and to the RIGHT OF 0, bring 33 (31) [45] needles to working position. Hang the center of marked skirt onto end needle on the RIGHT side. (wrong side facing you.) Distribute the skirt sts. evenly across to the LEFT DOUBLING THE STS. AS NEEDED. Work the same as you did for the back to the NECK SHAPING at Row 148 (156) [164]. SHAPE NECK: Bind off 6 sts. 1x, 3 sts. 1x, 2 sts. 2x. 1 st. 3x (5x) [7x] AT THE SAME TIME, SHAPE SHOULDER SAME AS THE BACK AFTER ROW 169 (181) [193] same as you did for the back.

LOWER SLEEVE:

Bring 72 (76) [80] needles to working position.
 Hang the open sts. of upper sleeve onto these needles.
 Be sure to hang the wide lace stripe end as shown on the chart doubling the sts. as needed across (approximately 2-2-2-2-1). Work in LACE ONLY (no stripes). Color 1.
 ON EACH SIDE, decrease 1 st. every 6th row 10x (11x) [12x] CHANGING THE TENSIONS AS SHOWN ON THE CHART.

AT ROW 65 (73 [81]) Set machine for SKIP, then bring every second needle to D (select) position and knit 1 row. (this is marking the row for hem). Release Skip Button and continue stockinette st. to Row 86 (94) [102] changing the tensions as shown on Chart. Pick up the loops formed by skip row and hang onto machine. Bind off loosely.

BELT: Make 3.

Cast on 3 sts. with color 1 and set machine for knitting a cord. Work until cord measures approximately 80". Make 2 cords with color 1 and 1 cord with color 2. Braid the center sections and allow ends to hang. Tie knots at loose ends. See Picture.

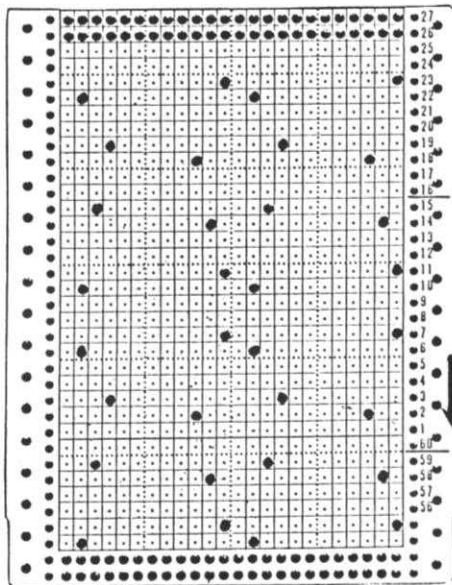
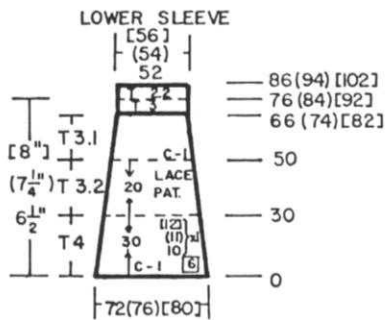

LACE & STRIPES PATTERN

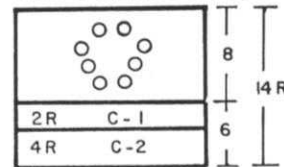

FINISHING:

See General Instructions.
 Work single crochet around neckline then 4 rows double crochet then 1 row picots.
 Work single crochet down open fronts. ON THE RIGHT FRONT, make loops for buttonholes (see picture).
 Work 2 rows single crochet around skirt edges.

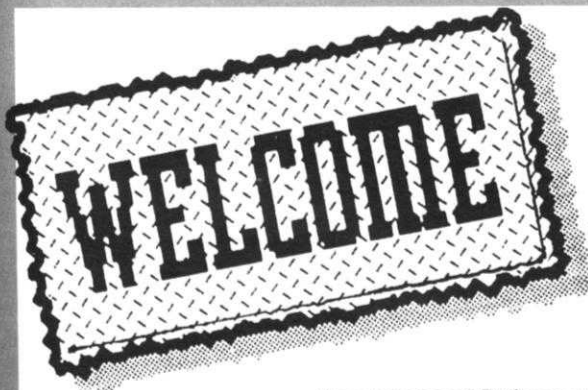

SEMINAR & OPEN HOUSE 1986

knitking

September 15 through 20.

Join us! Our open house runs from September 15 through 20 and will be held at KNITKING, 1128 Crenshaw Blvd, Los Angeles, Calif. 90019.

Come and meet our experts along with many acknowledged guest authorities. You'll get to see great new products too!

Enjoy! You'll love our daily Fashion Show and Contest! Daily winners will receive prizes and are eligible for the finals and a GRAND PRIZE at the close of the seminar.

Win! All types of garments are eligible, so start knitting now! (Sorry, knitting machine dealers and employees of KNITKING not eligible)

It's Free! Just bring yourself and some friends and join us for prizes, events, and free coffee and doughnuts.

Our regular seminar visitors will tell you ours is the best, so remember to come and meet us here at

KNITKING
 September 15 through 20.



WOMENS 3-PIECE ENSEMBLE

SIZES: 10/12 (14/16)
 YARN: Venetia and Viola
 AMOUNT:
 color 1 2 1/2 lbs. Venetia (15 1/2")
 color 2 1 ball Viola
 color 3 1 ball Viola 15"
 color 4 1 ball Viola
 Amount given is for all sizes.
 TENSION: 4 for Stockinette stitch.
 5 for Tuck Pattern
 Full needle Ribbing 4/3 II
 Ribbing 1/1 II
 GAUGE: Stockinette stitch
 16 sts. 26 rows = 2" (5 cm)
 Tuck stitch, Punch card.
 14 sts. 31 rows = 2" (5 cm)

The top is stockinette stitch with Full Needle Ribbing for the neckband. The Pants are Stockinette stitch. The Pullover Vest is a combination of Stockinette, Tuck and special rows of color. The bands are K1, P1 Ribbing. Can also be made on any Electronic machine. Draw Design on Mylar sheet.

TOP BACK:

Before knitting the back and front you will need 2 separate pieces of knitting - sometimes called a cast-on-rag to hang onto the machine at the underarm side edges. You can either knit this with waste yarn or you can use any sample swatch you have available that is made with Venetia or similar weight.
 With contrast waste yarn, cast on 58 (62) sts. After knitting 9 to 11 rows, knit 1 row with Ravel Cord to the right side.
 Change to garment yarn.
 Counter at 0.
 With color 1 continue in Stockinette stitch.
 Knit to Row 39 then knit Row 40 with yarn and thread for a MARKING ROW.
 AT SHOULDER EDGE, increase 1 st. (full fashion) every 10th row 24x (25x) and at UNDERARM EDGE, increase 1 st. (full fashion) every 14th row 11x (12x).
 AT THE SAME TIME, after Row 207 (213) AT UNDERARM, cast on 2 sts. 5x.

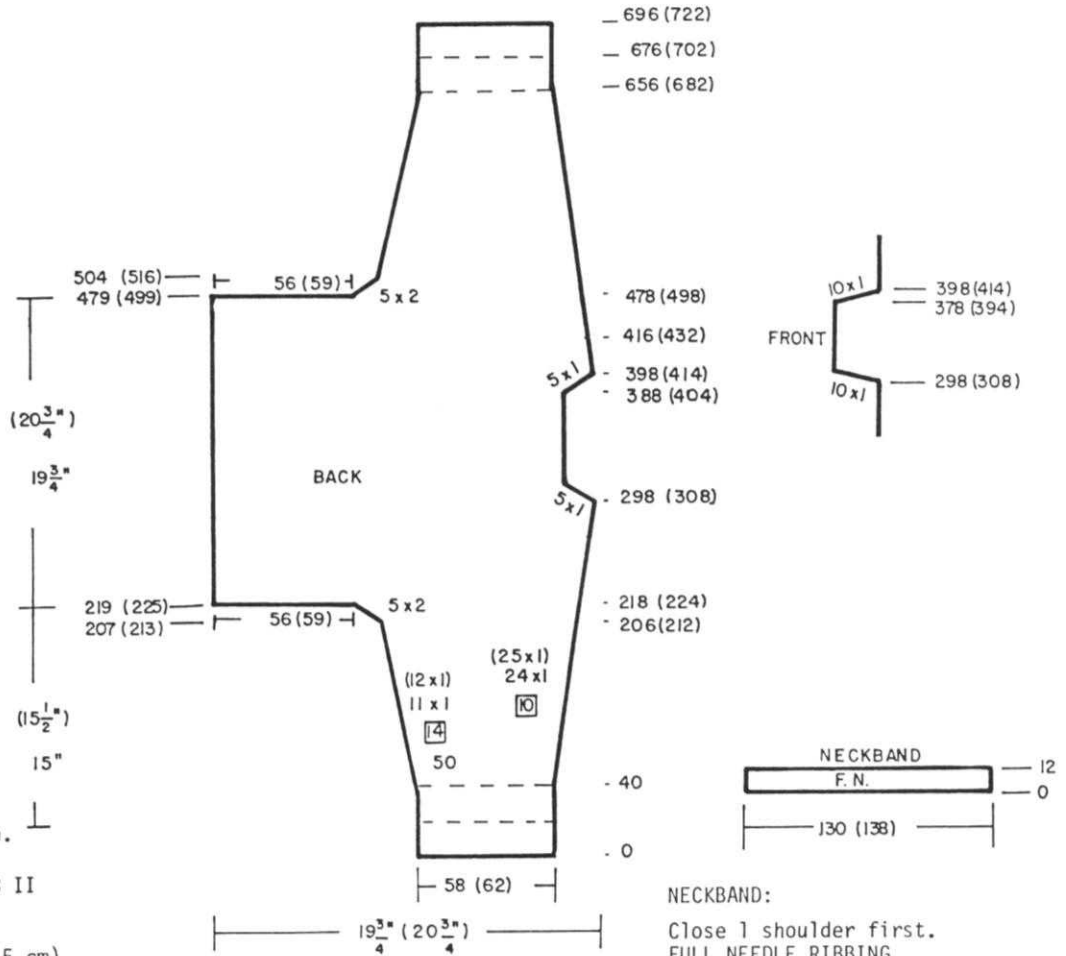

After Row 219 (225) HANG THE CAST ON STRIP at underarm edge over 56 (59) needles.
 Continue the shoulder increasing and after Row 298 (308) SHAPE NECK.
 Decrease 1 st. 5x.
 Knit to Row 388 (404) and ON NECK SIDE, increase 1 st. 5x.
 After Row 416 (432), ON SHOULDER SIDE, begin the FULL FASHION decreases every 10th row 24x (25x) and after Row 479 (499) ON UNDERARM SIDE, remove 56 (59) sts. onto waste yarn.
 AT UNDERARM, decrease 2 sts. 5x, then begin the underarm decreases after Row 504 (516).
 After Row 655 (681) knit next row with yarn and thread for a marking row.
 After Row 696 (822) remove the sts. onto contrast waste yarn.

TOP FRONT:

Work the front the same as the back with exception of NECK SHAPING.
 After Row 298 (308) AND ON NECK SIDE, decrease 1 st. 10x.
 Knit to Row 378 (394) then ON NECK SIDE, INCREASE 1 st. 10x.
 (See Chart).

NECKBAND:

Close 1 shoulder first.
 FULL NEEDLE RIBBING.
 Cast on 130 (138) sts. with color 1 and work 12 rows Ribbing. Transfer the ribber sts. to main machine, then pick up sts. around neck with wrong side facing you and bind off LOOSELY.

WAIST BAND - MAKE 2

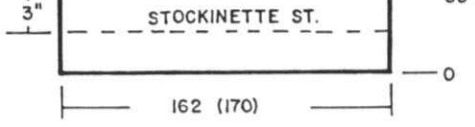

WAISTBAND: Make 2.

With contrast waste yarn, cast on 162 (170) sts. and work Stockinette stitch. After knitting 9 to 11 rows, knit 1 row with Ravel Cord to the left side. Change to color 1 and knit to Row 80.
 Pick up the first row of color 1 knitting and hang onto machine.
 Pick up sts. across front (or back) and hang onto same needles with purl side facing you. Knit 1 loose row then bind off loosely.

FINISHING: See General Instructions. Fold sleeve hem to the inside and using marked row as a guide, sew hem through the open sts. held on waste yarn. Pull out thread markings.

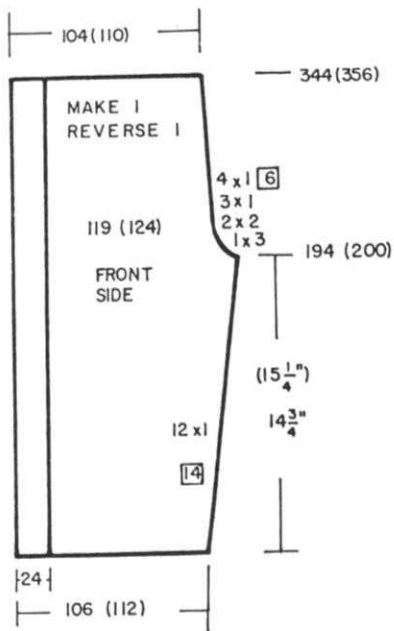

PANTS FRONT: Make 1, reverse 1.

Bring 106 (112) needles to working position, the PUSH BACK TO THE OUT OF WORK POSITION the 24th needle counting from the LEFT (right for second half) end. (You will latch this empty stitch into a knit stitch later).
 OPEN CAST ON same as before. After waste knitting, change to color 1 and continue in stockinette stitch. Put counter at 0.
 ON INSIDE EDGE, increase 1 st. every 14th row 12x.
 After Row 194 (200), SHAPE CROTCH: Bind off 3 sts. 1x, 2 sts. 2x, 1 st. 3x, 1 st. every 6th row 4x.
 After Row 344 (356), remove the knitting onto contrast waste yarn. MAKE SECOND HALF WITH REVERSE SHAPING.

PANTS LEG AND WAIST BANDS:

Before you can make the bands, you must make the pleats. First, working from the PURL side, latch up the spaces left by the out of work needles on the front sections. Using a sewing machine, slip stitch crochet or a back stitch, close side seams of front and back. Fold and press the latched up edge and side seams. Still working on the purl (wrong) side, count 6 sts. from the latched up stitches and fold it to the right over 6 more stitches. Pin or baste in place. ON THE BACK section, count over 6 sts. from the seam and fold it to the right over 6 more stitches. Bast or pin in place. REVERSE the pleats for other side.

PANTS BACK: Make 1, reverse 1.

OPEN CAST ON 88 (94) sts. same as you did for the Top. After waste knitting, change to color 1 and counter at 0.
 ON INSIDE EDGE, increase 1 st. every 14th row 7x, every 8th row 2x, every 6th row 10x, every 4th row 4x, then increase 1 st. 1x.
 After Row 193 (199), SHAPE CROTCH: Bind off 5 sts. 1x, 4 sts. 1x, 3 sts. 1x, 2 sts. 1x, 1 st. 4x, 1 st. every 4th row 2x, 1 st. every 6th row 1x, then 1 st. every 10th row 13x.
 After Row 345 (357) WORK SHORT ROWS: ON OPPOSITE SIDE OF CARRIAGE, put into holding position 13 (14) sts. 6x.
 After Row 357 (369) bring all needles to working position, knit 1 row, then remove the sts. onto contrast waste yarn. REVERSE SHAPING for 2nd section.

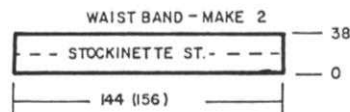
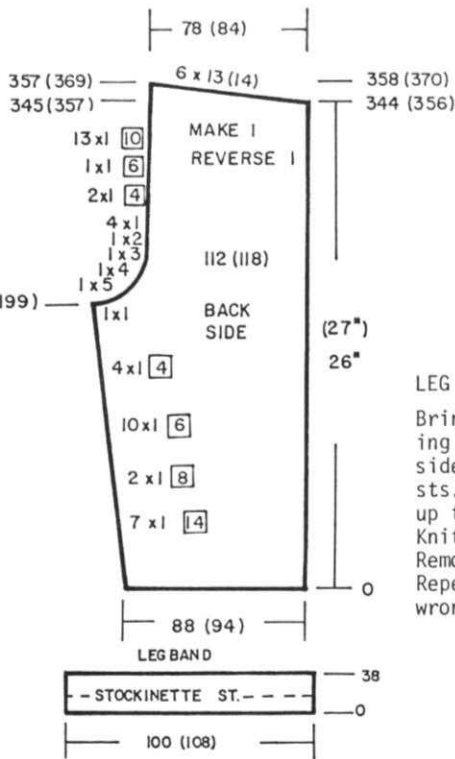

WAISTBAND: Make 2.

Bring 144 (156) needles into working position and work the same as for the leg bands.
 When bands are completed, close center back and front and inner leg seams. Leave opening for elastic at waist, insert elastic then close opening.

LEG BANDS: Make 2

Bring 100 (108) needles into working position and with KNIT (right) side facing you, pick up the open sts. of leg, making sure you pick up the tripled sts. of pleats. Knit 38 rows Stockinette stitch. Remove the sts. onto waste yarn. Repeat for other leg. Fold to the wrong side and sew in place.

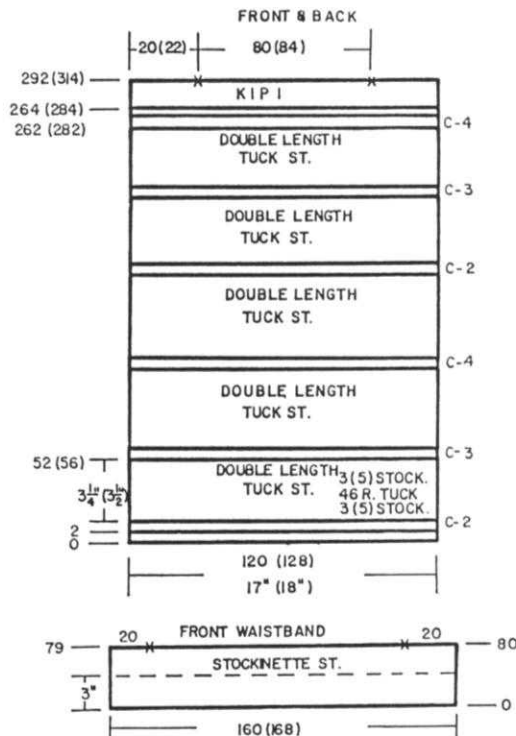

VEST FRONT:

OPEN CAST ON with waste yarn for Waistband FIRST.
 160 (168) sts. Knit 9 to 11 rows then 1 row with Ravel Cord to the RIGHT SIDE.
 Change to color 1 and work 79 rows. Carriage on the LEFT.
 Pick up the first row of garment yarn and hang onto the machine to form a hem. Knit 1 row.
 Carefully remove the waste yarn THEN ON EACH SIDE, REMOVE 20 sts. onto separate contrast waste yarn. CUT YARN AND BRING CARRIAGE TO THE LEFT SIDE. Continue with FRONT (see Chart).
 COUNTER AT 0. With color 1 knit 2 rows.
 With VIOLA (color 2) HAND KNIT the sts. pulling each stitch back to 'A' position. DO NOT COUNT the hand knit rows. Hang weights, are carefully pull the needles to working (B) position.
 Insert Card in machine, locked on Row 1.

*Knit 2 (4) rows. SET PATTERN ON NEXT ROW FROM LEFT TO RIGHT. RELEASE CARD AND ELONGATE PATTERN. SET MACHINE FOR TUCK.
 Work 46 rows TUCK PATTERN. STOP CARD. CARRIAGE ON THE RIGHT. Knit 3 (5) rows. CARRIAGE ON THE LEFT.
 Knit 1 row BY HAND with VIOLA (color 3)
 LOCK CARD ON ROW 1.
 REPEAT FROM *, changing the colors of VIOLA each time you work the hand knit row (SEE CHART).
 After Row 262 (282), work the hand knit row. Knit 2 rows color 1 then transfer every other stitch to the Ribber and work 30 rows K1, P1 Ribbing. Transfer the ribber sts. to main machine then bind off each section separately for neck and shoulders, LOOSELY, IN RIBBING.

CONTINUED

VEST BACK:

MAKE THE BACK THE SAME AS YOU DID THE FRONT EXCEPT FOR THE WAISTBAND.

Cast on 184 (192) sts.

After forming the hem, knit 1 row then ON EACH SIDE, remove 32 sts. onto contrast waste yarn. Cut yarn and bring carriage to the left side. COUNTER AT 0. Continue in the same way as you did for the front.

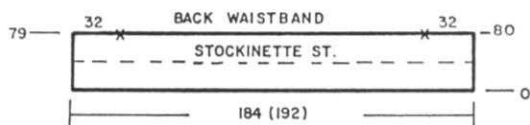

SIDE BANDS: Make 4.

With color 1, cast on 167 (179) sts. and work 30 rows K1, P1 Ribbing. Transfer the ribber sts. to main machine then with KNIT (wrong) side facing you, pick up sts. evenly along side edge from shoulder to lower edge of band. Bind off LOOSELY.

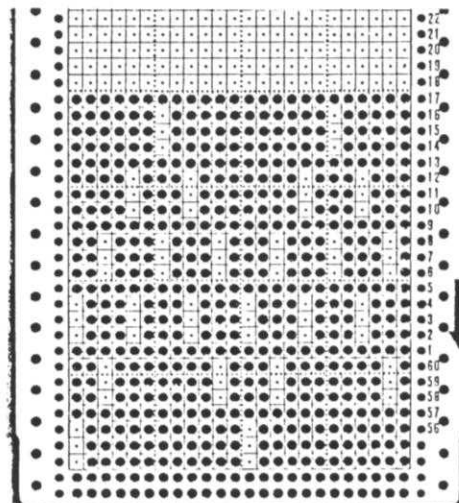
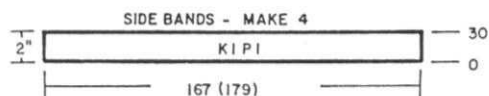

FINISHING:

Close shoulders. Weave side bands to waist bands. Work single crochet through remaining waistband stitches. Remove the waste knitting. Bring back waistband over front band then sew 2 button on each side.



WOMENS PULLOVER

SIZES: 6/8 (10/12) [14/16]

YARN: Regia = color 1 and 2
Show = color 3

AMOUNT:

color 1 5 6 6 balls
color 2 2 balls for all sizes.
color 3 1 ball for all sizes.

TENSION: 6.1 Rib. 5/4 II

GAUGE: 15 sts. 22 rows = 2" (5 cm)

Stockinette stitch with SHORT ROWS for the Design.
Bands K1, P1 Ribbing. Knitted sideways on the machine.

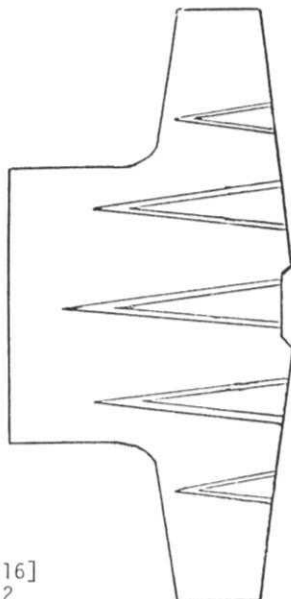

BACK:

With contrast waste yarn, cast on 54 (58) [62] sts.

knitting 9 to 11 rows, knit 1 row with Ravel Cord to the right side. Change to color 1 and put Counter at 0.

ON THE RIGHT, increase 1 st. every 10th row 5x (6x) [6x] AND ON THE LEFT, increase 1 st. every 10th row 7x (8x) [8x].

After Row 53 (61) [69], WORK SHORT ROWS. ON OPPOSITE SIDE OF CARRIAGE, bring into holding position 6 sts. 10x 6 (12) [16] sts. remain. ALL NEEDLES IN WORK, knit 1 row. WORK SHORT ROWS FOR PATTERN (DO NOT COUNT PATTERN SHORT ROWS). ON OPPOSITE SIDE OF CARRIAGE, bring into holding position 6 (12) [16] sts.

With color 2, knit 2 rows. ON OPPOSITE SIDE OF CARRIAGE, bring into holding position 4 sts. 4x.

Bring 4 sts. to holding position 40 sts. are left in work, all others in holding. With color 3, knit 2 rows. Bring into holding position 8 sts. 4x. 8 sts. remain in color 3.

Bring 4 sts. to holding position and knit 2 rows.

Push back into working position 8 sts. 4x (4 sts. remain in color 3).

Change to color 2 and knit 2 rows over 40 sts.

Push back into working position 4 sts. 4x (4 sts. remain in color 2). ROW 74 (82) [90] With color 1, knit 1 row over ALL STS.

Bring 60 sts. on the RIGHT into holding position. Knit 2 rows. Push back into working position 6 sts. 10x BUT AT THE SAME TIME, increase 1 st. on the LEFT every 10th row 5x.

After Row 94 (102) [110] ON THE RIGHT, increase 1 st. every 10th row 3x.

After Row 119 (127) [135] ON THE LEFT, cast on 2 sts. 5x. After Row 130 (138) [146], ON THE LEFT, cast on 52 (54) [58] sts. (USE A CAST ON RAG OR WASTE KNITTING).

After Row 135 (143) [151], ON OPPOSITE SIDE OF CARRIAGE, put into holding position 11 sts. 9x.

All needles in work, knit 1 row to the RIGHT. Continue in this way, follow the CHART for Pattern and changes in color.

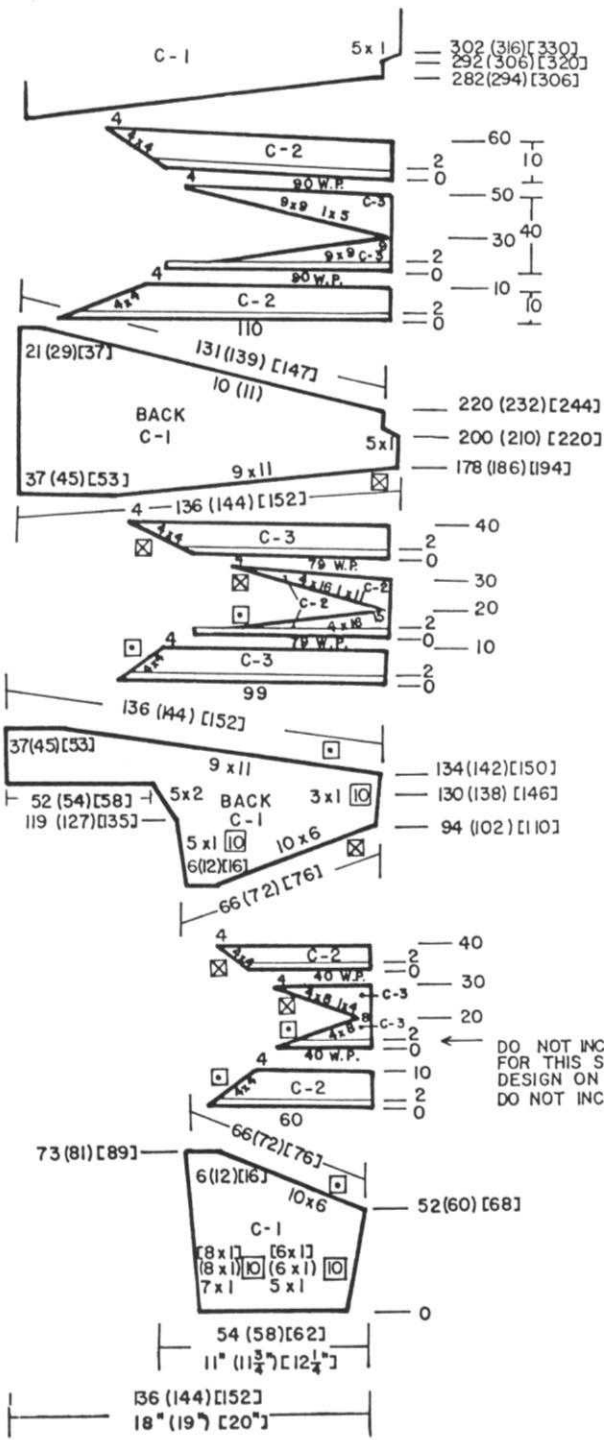

FRONT:
 Work the front the same as back with exception of NECK SHAPING. FOR NECK, after Row 200 (210) [220], decrease 1 st. 10x. After Row 282 (296) [310], increase 1 st. 10x.

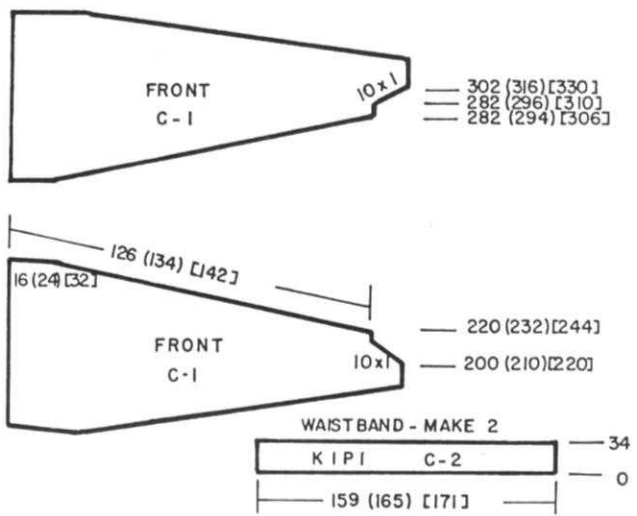

WAISTBAND: Make 2. K1, P1 Ribbing. With color 2, cast on 159 (165) [171] sts. and work 34 rows K1, P1 Ribbing. Transfer the ribber sts. to main machine, then pick up sts. along waist edge and hang onto these needles, spacing them evenly across. Knit 1 row then bind off loosely.

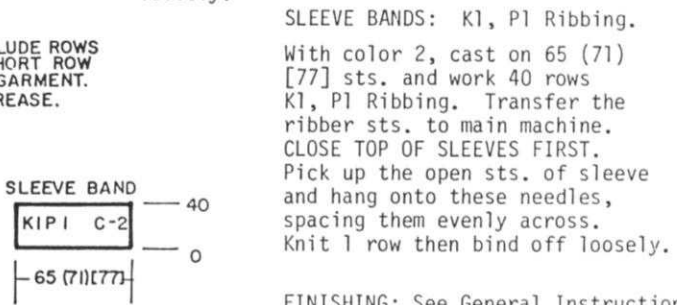

SLEEVE BANDS: K1, P1 Ribbing. With color 2, cast on 65 (71) [77] sts. and work 40 rows K1, P1 Ribbing. Transfer the ribber sts. to main machine. CLOSE TOP OF SLEEVES FIRST. Pick up the open sts. of sleeve and hang onto these needles, spacing them evenly across. Knit 1 row then bind off loosely.

FINISHING: See General Instructions. Work 1 row single crochet around neck edge.

MACHINE KNITTING FASHION

The leading knitting publication from England. It contains 36 complete and outstanding patterns for women, men and children. Illustrated in full color this edition (8 1/2"x11") has a special group of patterns using the Garter Carriage.

Garments are knitted with Punch Card, Electronic and Bulky machines. At \$6.95 postpaid anywhere in the world, its definitely a 'Best Buy'.

Order direct from KNITKING
 1128 Crenshaw Blvd., Los Angeles CA 90019

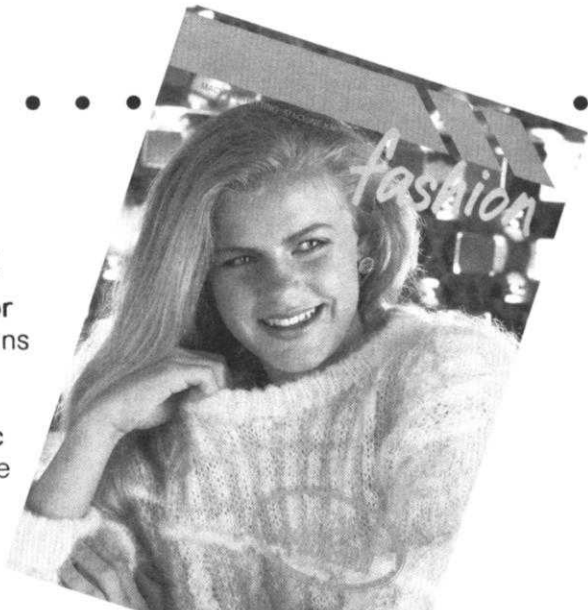



WOMENS AZTEC DRESS

SIZES: 10/12 (14/16)
 YARN: Venetia, Isabella
 AMOUNT:

- color 1 1 lb. Venetia
- color 2 5 balls Isabella
- color 3 15 balls Isabella
- color 4 3 balls Isabella
- color 5 2 balls Isabella
- color 6 1 ball Isabella

FOR ALL SIZES

TENSION: 4 Venetia - Rib. 3/3 I
 GAUGE: 16 sts. 25 rows = 5 cm (2")
 in Stockinette stitch.

You will need 36 1/2" Wooden Beads with large hole. 1 Pair soft shoulder Pads.

Stockinette stitch and FULL NEEDLE ribbing for Pattern using color 1 and contrast colors as shown. USE FINE NEEDLE BAR and Color Changer - with KR 900 RIBBER. IMPORTANT: - FULL NEEDLE RIBBING WITH COLOR CHANGER for KR 900 Ribber - Fine Needle Bar. For FAIR ISLE PATTERN.

In order for the Rib knitting to be correct, you must be sure the end needles on the RIBBER are an ODD NUMBERED NEEDLE. Use the Ribber Selecting strip as a guide - for instance: If you need 60 sts. on the RIBBER, you must NOT USE 30 on each side of 0 but should use needle 29 on one side and needle 31 on the other side of 0 (an ODD NUMBERED NEEDLE) which will give you the 60 sts. The end needles on the machine should always be a KNITTER NEEDLE. Be sure to read pages 38 and 39 of your KR 900 Ribber Manual. PUNCH 5 CARDS.

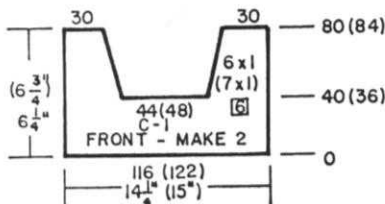

BACK & FRONT:
 Make this first.

FULL NEEDLE RIBBING. Cast on 180 (192) sts. with color 2. Knit 8 rows. Knit 4 rows color 3. Knit 7 rows color 2. Insert Pattern Card 1. Lock Card, knit 1 row to the right to select the needles. RELEASE CARD. Set Main Machine for SKIP. Put BOTH CHANGE KNOBS ON RIBBER to the OUTSIDE and SLIDE LEVER in the CENTER, BOTH Cam Levers UP (SKIP). Knit 1 row to the LEFT. *Change to color 3, knit 2 rows. Change to color 2, knit 2 rows. REPEAT FROM * until Pattern 1 is completed.

Remove Punch Card and put MAIN MACHINE CARRIAGE CONTROLS TO NORMAL. Knit 20 rows color 2. After Row 100, transfer the ribber sts. to main machine and continue in Stockinette stitch with color 1. Knit to Row 260 (264). ON EACH SIDE, FULL FASHION decrease, 1 st. every 14th row 7x. Knit to Row 446 (456). ON EACH SIDE, decrease (FULL FASHION) 1 st. every 2nd row 10x. After Row 466 (476), remove the sts. onto contrast waste yarn. Make 2nd section the same.

BACK BODICE: MAKE 2 (1 is for Lining).

With contrast waste yarn, OPEN CAST ON 116 (122) sts. After knitting 9 to 11 rows, knit 1 row Ravel Cord to the right side. Change to color 1 and continue in Stockinette stitch. After Row 52 (54), bind off the center 44 (48) sts. put the needles on the left into holding position and complete the right side first.

*ON NECK SIDE, decrease 1 st. every 4th row 6x (7x). After Row 80 (84), remove the sts. onto contrast yarn. Bring the needles on the left into working position, knit 1 row to the left side and turn the Row Counter back to 52 (54) and complete the left half. Follow the instructions from *. Make 2nd section.

FRONT BODICE: MAKE 2 (1 is for Lining).

Work the same as the back to Row 40 (36). SHAPE NECK: Bind off the center 44 (48) sts. put the needles on the left into holding position and complete the right side first. *ON NECK SIDE, decrease 1 st. every 6th row 6x (7x). After Row 80 (84), remove the sts. onto contrast yarn. Bring the needles on the left into working position, knit 1 row to the left side, turn the Row Counter back to 40 (36) and complete the left half. Follow the instructions from *. Make 2nd section.

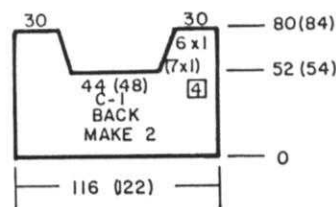
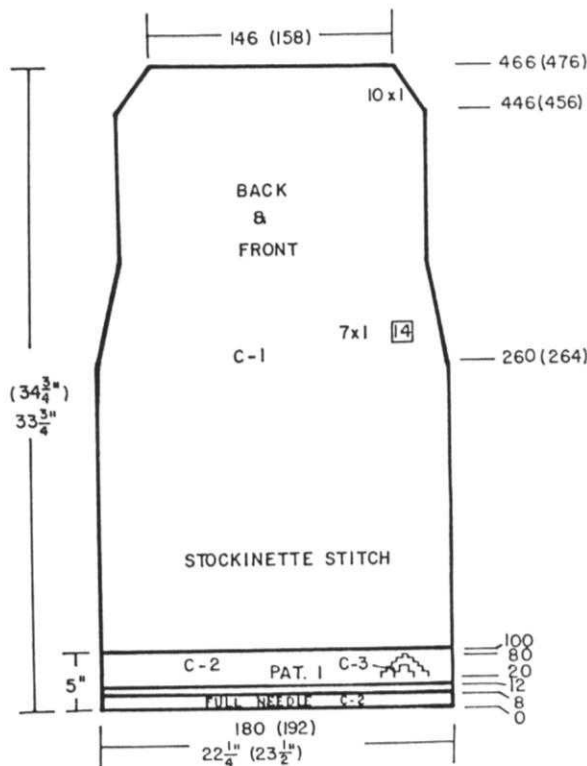

DECORATIVE FRONT PANEL
 Knit FRONT AND BACK FIRST.
 FULL NEEDLE RIBBING. Cast on 72 sts. with color 3. Knit 7 rows. SET PATTERN 5. SEE INSTRUCTIONS FOR FRONT AND BACK FOR SETTING ALL CONTROLS ON MACHINE. When Pattern 5 is completed, RELEASE MAIN CARRIAGE CONTROLS (TO NORMAL). Knit 6 rows color 3. Set the next Pattern in the same way as before, changing colors as shown on the Chart. When the 12th Pattern is completed, RELEASE MAIN CARRIAGE CONTROLS. Knit 20 (30) rows color 3. Transfer the ribber sts. to main machine. Knit 1 row Stockinette stitch then remove the sts. onto contrast waste yarn

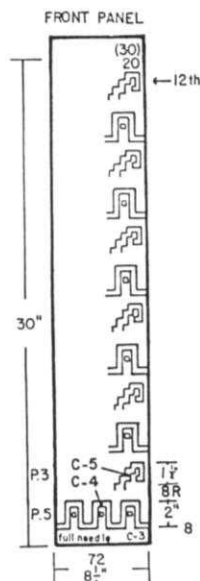

SEPARATE FAIR ISLE YOKE:
with Fringe and Beads.

Please make the Front and Back FIRST so that you will understand the changes in Pattern and colors.

BACK:
FULL NEEDLE RIBBING:
Cast on 98 sts. with color 3.

Follow the SAME INSTRUCTIONS as the FRONT & BACK for setting Patterns and changing colors. AT THE SAME TIME, increase 1 st. ON EACH SIDE every 10th row 18x and continue in Patterns as shown on the Chart to Row 188.

Bind off the center 48 sts. With a Ravel Cord, knit the sts. on each bed, pulling the sts. back to 'A' position (out of work) and complete the right side first.

*ON NECK SIDE, decrease 1 st. every 4th row 7x BUT AT THE SAME TIME, after Row 190, set PATTERN 4.

After Row 228, transfer the ribber sts. to main machine, knit 1 row then remove the sts. onto contrast waste yarn.

Carefully bring the needles of both beds back to working position and remove the Ravel Cord. Go back to Row 188 and complete the left half. Follow the instructions from *.

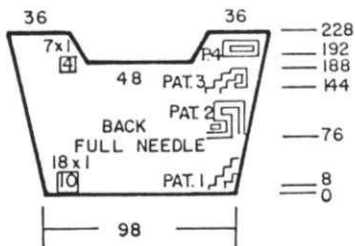

PAT. 1

FINISHING:

FRONT & BACK BODICE:

With right sides together, sew bodice and lining together around the armhole edges and side edges. Be sure to leave SHOULDERS and LOWER EDGES OPEN. You can sew with sewing machine OR slip stitch/crochet the sections together. Turn to the right side.

Bring 116 (122) needles into working position.

With RIGHT SIDE FACING YOU, hang the FRONT BODICE (not lining) held on waste yarn onto these needles. Carefully remove the waste knitting. Check to see that you have not dropped stitches. With WRONG SIDE FACING YOU, hang the Decorative front panel onto the needles, CENTERING the panel.

Remove the waste knitting carefully.

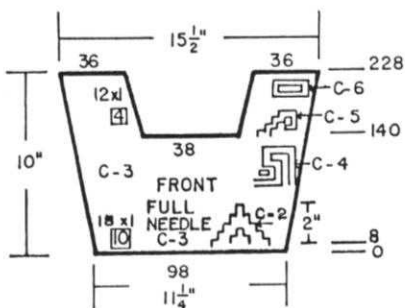
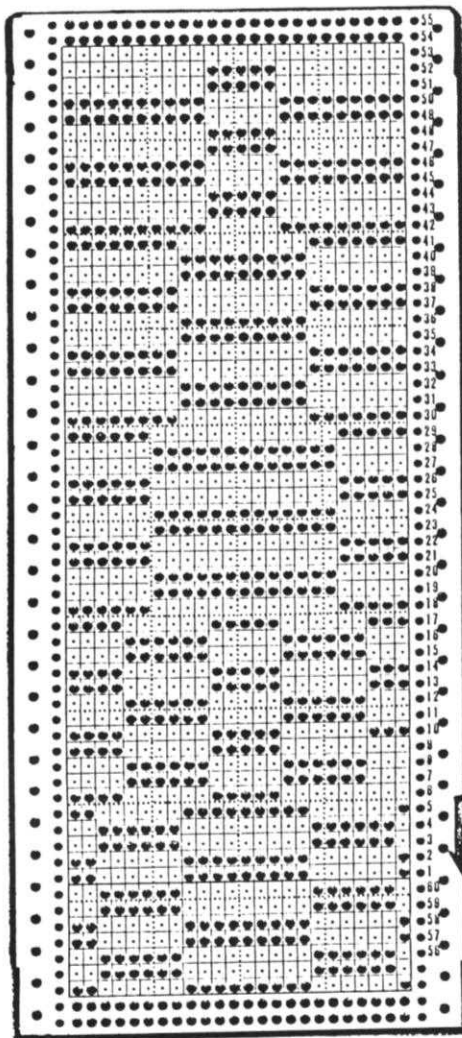

PAT. 2

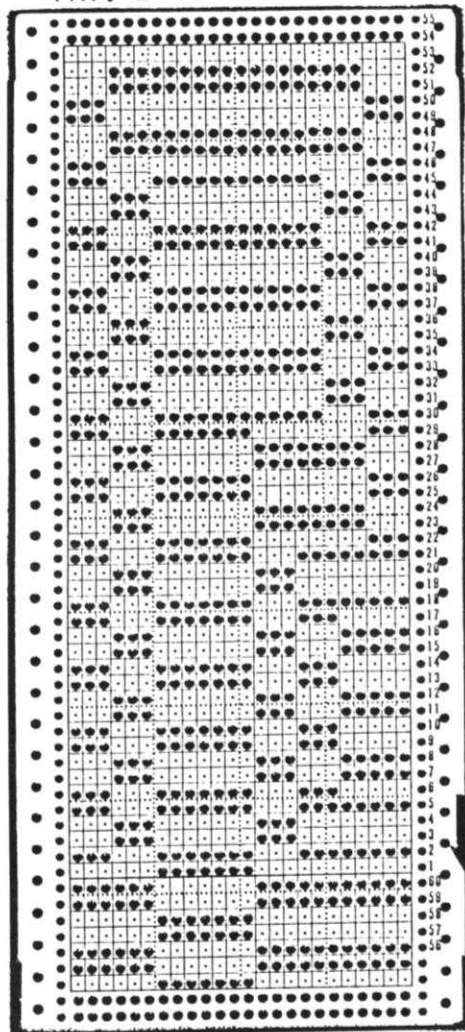

SEPARATE FAIR ISLE YOKE:
FRONT:

Work the front the same as the back with exception of neck shaping. After Row 140, bind off the center 38 sts. Put the needles on the left from both beds onto a Ravel Cord to 'A' position in the same way as you did for the back. Complete the right side first.

*ON NECK SIDE, decrease 1 st. every 4th row 12x, BUT AT THE SAME TIME, after Row 142, set PATTERN 3. After Row 228, transfer the ribber sts. to main machine, knit 1 row then remove the sts. onto contrast waste yarn.

Bring the needles on the left into working position and remove the Ravel Cord.

Go back to Row 140 and complete the left half. Follow the instructions from *.

With WRONG SIDE FACING you, hang the open sts. of FRONT (skirt section) onto the same needles, DECREASING EVENLY ACROSS (approximately every 5th (4th) stitch). Remove the waste knitting. Be sure all needles are now brought to 'E' (holding) position then knit 1 very loose row across slowly. Bind off LOOSELY.

REPEAT THE SAME PROCEDURE FOR THE BACK OMITTING THE FRONT PANEL.

Weave the SHOULDER LINING STS. TOGETHER. Attach shoulder pads to the wrong side of lining then weave the RIGHT SIDE OF BODICE SHOULDER STS. TOGETHER.

Close side seams.

FAIR ISLE YOKE: - Weave the shoulders together. With DOUBLE strand of yarn, work single crochet around neckline. With DOUBLE strand of yarn, work 1 row single crochet across SIDE EDGES, then with SINGLE strand, work slip st, chain 3, skip 2 sts. slip st. into next stitch. and repeat across.

FRINGE: Cut an 11" cardboard then wind around cardboard - 6 strands for each fringe. Cut only 1 end. Fold in half and knot into the ch 3 loops.

Slip bead onto first set of fringe and knot in place approximately 1" from top. On next set, slip bead and knot 1" down from first bead and on 3rd set, knot bead 1" down from 2nd bead. SKIP 10 and knot beads in the same manner on next 3 sets of fringe. REPEAT ACROSS then place beads on other side in the same way. (See Picture).

CONTINUED

PAT. 3

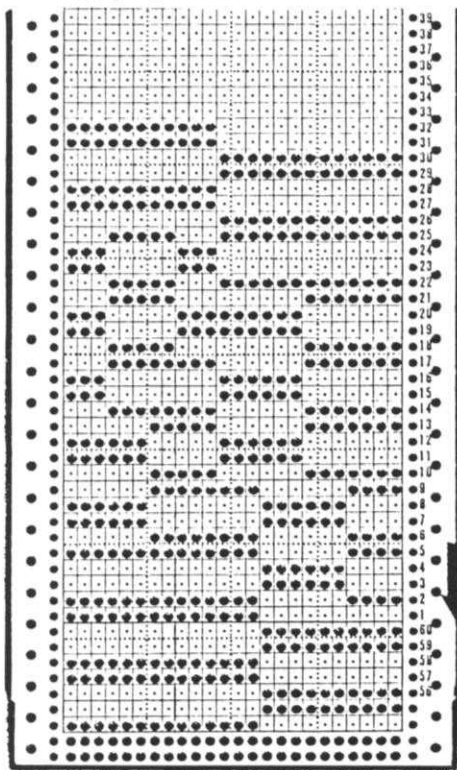

PAT. 4

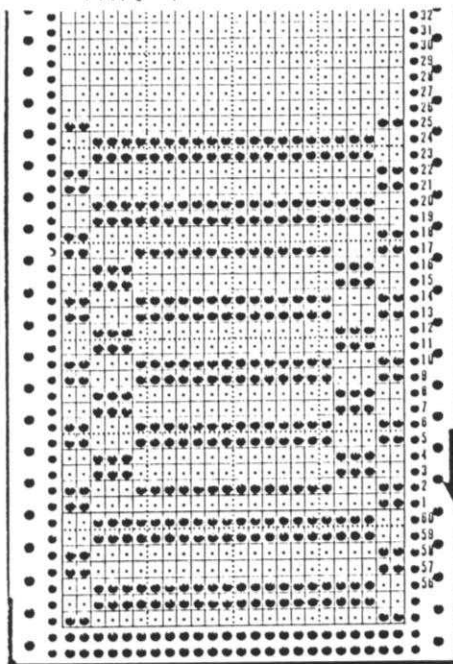

PAT. 5

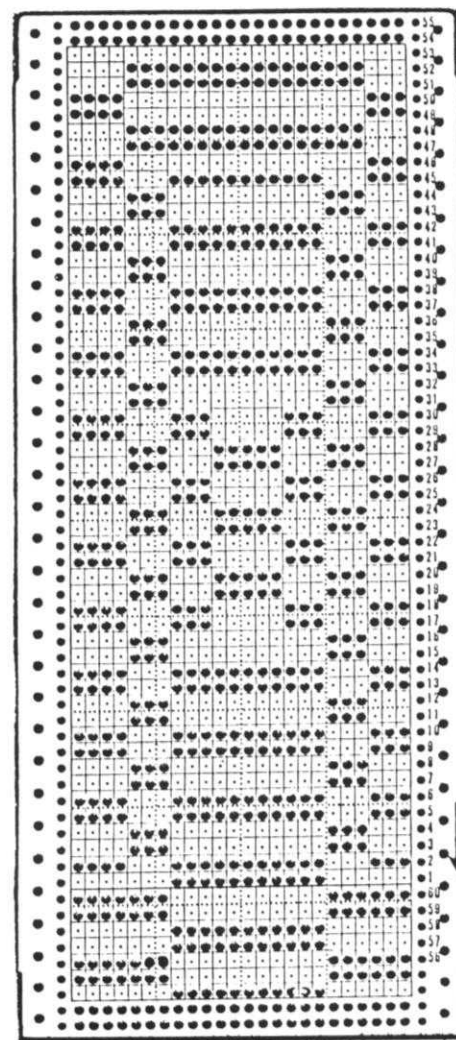

WOMENS TWO-PIECE DRESS

SIZES: 8/10 (12/14)
 YARN: VENETIA
 AMOUNT: 2 lbs. for all sizes.
 TENSION: 4 for Top
 FULL NEEDLE RIBBING 4/4 I
 Bands 3/2 I
 GAUGE: 14 sts. 26 rows = 2" (5 cm)
 for Top.

The Top is an isolated Lace Design, made on the KH 910 machine. Bands are Full Needle Ribbing for sleeve and neck. 1 x 1 ribbing for waist-band.
 The Skirt - Full Needle Ribbing Pattern as shown on the Chart.

The Butterfly design is taken from the Brother set of 4 books, "Lace Pattern Book No. 3".

LACE TOP - BACK:

Use 2 strands of yarn for the 1 x 1 Ribbing. Tension 4/4. Cast on 131 (141) sts. and work 30 rows K1, P1 Ribbing. Transfer the ribber sts. to main machine and increase 1 st. on the right side. CONTINUE LACE PATTERN USING 1 STRAND OF YARN.

IMPORTANT: When working in the Pattern, to avoid having another part of Butterfly show, (besides the two in center) bring every other needle to 'D' (selecting) position (EACH SIDE) BEFORE USING THE LACE CARRIAGE.

This will continue the EYELET LACE to edge of sleeves. After Row 164 (166), ON EACH SIDE, increase 1 st. 14x (16x). Continue in Pattern to Row 296 (308). MARK ROW ON SHEET. Bind off the center 12 (18) sts. Put the needles on the left into holding position (A position with ravel cord) and work the right side first.

*SHAPE SHOULDER AND NECK AT THE SAME TIME.

FOR SHOULDER, bind off 15 sts. 2x, 14 sts. 2x (16 sts. 2x, 15 sts. 2x)
 FOR NECK, bind off 4 sts. 4x. Bring the needles on the left to working position. Set Pattern to correct row, Row Counter back to 296 (308) and complete the left half. Follow the Instructions from *.

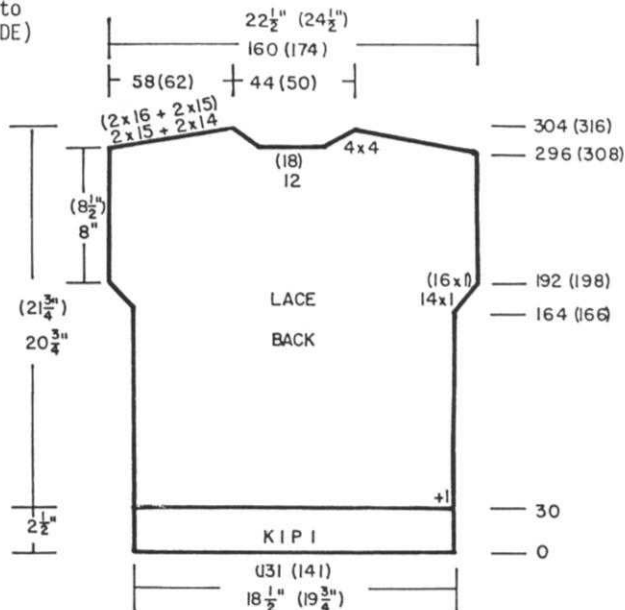

LACE TOP FRONT:

Work the front the same as the back to Row 214 (222). Mark Row on Sheet. Bind off the center 12 (18) sts. and put the needles on the left into holding position (A) position same as you did for the back. Work the right side first.
 *ON NECK SIDE, bind off 4 sts. 1x, 3 sts. 1x, 2 sts. 1x, 1 st. 7x and after Row 296 (308) SHAPE SHOULDER SAME AS THE BACK. Bring the needles on the left into working position, Set Pattern on marked row, turn Row Counter to 214 (222) and complete the left half. Follow the instructions from *.

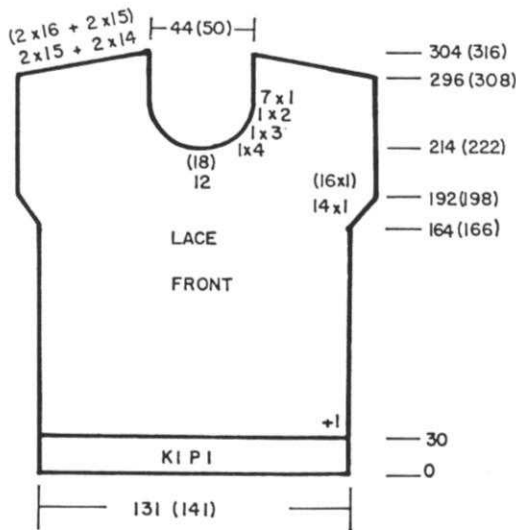

NECKBAND: FULL NEEDLE RIB.

Cast on 174 (190) sts. and work 14 rows full needle ribbing. Transfer the ribber sts. to main machine. Close one shoulder first, then with wrong side facing you, pick up sts. around neckline from shoulder to shoulder AS SHOWN ON THE CHART. Bind off LOOSELY.

SLEEVE BANDS: Make 2. FULL NEEDLE RIBBING.

Cast on 106 (112) sts. and work 14 rows full needle ribbing. Transfer the ribber sts. to main machine then pick up the sts. along sleeve edge. Bind off LOOSELY.

FINISHING: See General Instructions. Close shoulder and neckband.

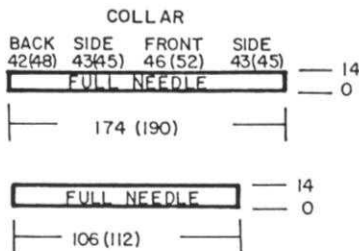

SKIRT: MAKE 3 PANELS FULL NEEDLE RIB.

Cast on 141 sts. MARK THE NEEDLE BED OF MAIN MACHINE AS FOLLOWS: To the LEFT of 0, mark needle 4 then every 5th needle to the left. To the RIGHT OF 0, mark needles 2, 7, then every 5th needle to the right. ON THE RIBBER BED, to the LEFT of 0 mark needles 2, 3, 7, 8, then every 4th and 5th needle to the left. on the RIGHT of 0, mark needles 3, 4, 8, 9 then every 4th and 5th needle to the right. Knit to Row 70 with Tension 3.2/3.2 I. From here on please watch for the changes in Tension as shown on the Chart.

ON THE MAIN MACHINE, transfer the 4th st. to the LEFT of 0 to the next needle on the LEFT. Put empty needle OUT OF WORK (A position). ON THE MAIN MACHINE, transfer needle 67 on the right side of 0 to the next needle on the left. Put empty needle out of work. ON THE RIBBER and in the center of the panel, transfer needle 2 to the right and needle 3 to the left. Put empty needles out of work and on the right, transfer needle 69 to the right and 68 to the left and put empty needles out of work. Now you can follow the CHART for the Design, each time adding the required number of special rib patterns, transferring marked st. on main machine and the marked sts. on the Ribber. Always put the empty needles out of work. WATCH FOR CHANGES IN TENSION. IMPORTANT: ON EACH SIDE OF 0, as you form the design, the stitches on the main machine should always transfer to the INSIDE. After Row 320 (334), transfer the ribber sts. to main machine (SET RIBBER TO *P* to make it easy to transfer the sts.) Knit 1 row Stockinette stitch and remove the sts. onto contrast waste yarn.

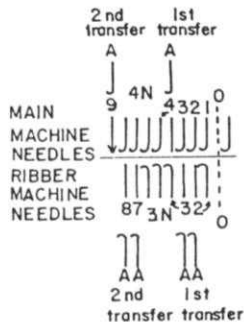

SKIRT - ONE PANEL - MAKE 3 PANELS

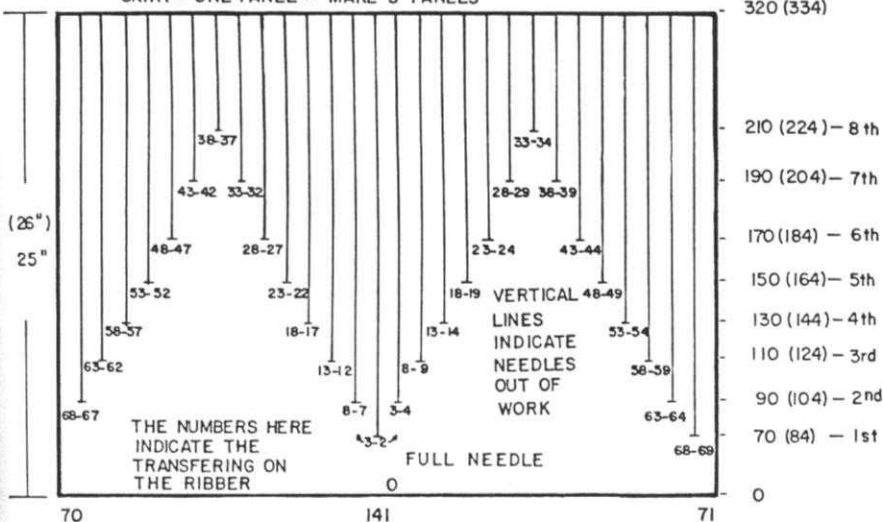

CHANGE TENSIONS AFTER ROWS:

- T 1/1
- R 280
- T 1.1/1.1
- R 240
- T 1.2/1.2
- R 150
- T 2.1/2.1
- R 110
- T 3/3
- R 70
- T 3.2/3.2

WAIST BAND - MAKE 3

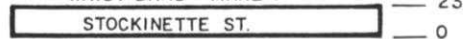

Bring 85 needles into working position. With wrong side facing you. Hang the open sts. of 1 section onto these needles doubling the sts. as follows - 2-2-1 and repeat across. Knit 1 loose row (tension 10). Change to Tension 4 and knit 23 rows. Pick up the sts. from the tension 10 row then bind off loosely. FINISHING: Weave all seams together leaving opening at waist edge for 1 section then insert elastic and close opening.

CONTINUED



LEFT FRONT & POCKET.

Make the 2 pockets first. BEGIN AND END POCKETS with WASTE YARN. Cast on 24 sts. and knit 24 rows stockinette stitch. Remove onto waste yarn and put aside.

FRONT: - Cast on 39 (43) sts. and work 10 rows K1, P Ribbing.

Transfer the ribber sts. to main machine and continue in Stockinette stitch. FIRST, WITH KNIT SIDE FACING YOU, hang pocket beginning with the 5th (7th) needle counting from side edge, leave the pocket hanging. Continue to knit to Row 52. Bind off or remove onto waste yarn, the 24 sts. for pocket opening then hang the other end of pocket lining onto the empty needles. Continue knitting in stockinette stitch.

After Row 80, ON NECK SIDE, FULL FASHION DECREASE, 1 st. every 8th row 11x (1 st. every 7th row 14x), BUT AT THE SAME TIME, after Row 110 SHAPE THE ARMHOLE and BEGIN THE CABLE SAME AS YOU DID FOR THE BACK. After Row 172, remove the sts. onto waste yarn.

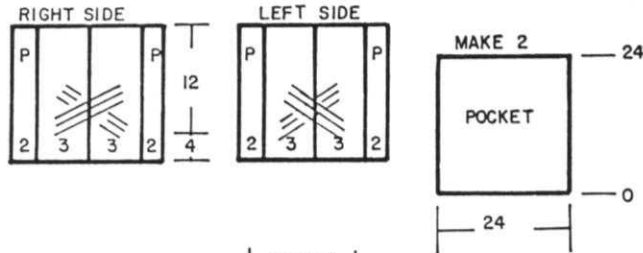

WOMENS BULKY JACKET

SIZES: Medium (Large)
YARN: Special KIT yarn only available in color as shown in Photograph. See Kits.
AMOUNT: 2 1/2 lbs. for both sizes. USE 4 STRANDS.
TENSION: 9.2 Rib. 1.1/1
GAUGE: 7.5 sts. 10 rows = 2" (5 cm)

Knit Jacket on any BULKY MACHINE with Ribber. Cable Design on each side of back and fronts. Bands are K1, P1 Ribbing.

BACK:

Cast on 77 (81) sts. with 4 STRANDS of YARN and work 10 rows K1, P1 Ribbing. Transfer the ribber sts. to main machine and increase 1 st. on the right side.

Continue in Stockinette stitch. After Row 110, SHAPE ARMHOLE and at the same time, you will work the CABLES on each side so mark the NEEDLE BED on each side 7 sts. in to make it easy for you. ARMHOLE SHAPING ON EACH SIDE - decrease 1 st. FULL FASHION METHOD every 2nd row 5x but after the 4th row, make cables on each side as shown on the Chart. Continue making the cables every 12th row and be sure to LATCH UP the 2 sts. on each side of cable into a knit stitch frequently (don't wait till last minute for latching the stitches and be sure to only drop 1 st. at a time).

After Row 166, remove the center 14 (16) sts. onto waste yarn. Put the needles on the left into holding position and complete the right side first. *ON NECK SIDE, bind off 2 sts. 2x. After Row 172, remove the sts. onto waste yarn. Move the Carriage to the left side. Bring the needles into working position, turn the Row Counter back to 166 and complete the left half. Follow the instructions from *.

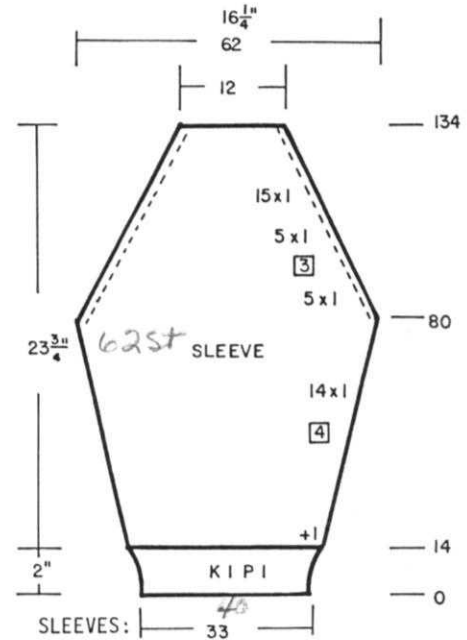
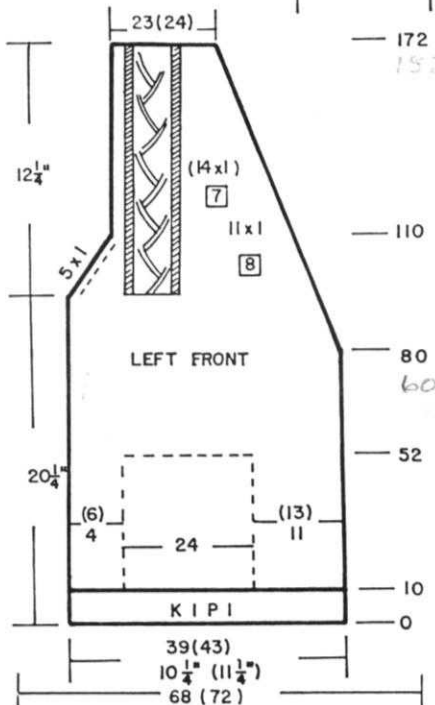

Cast on 33 sts. and work 14 rows K1, P1 Ribbing. Transfer the ribber sts. to main machine and increase 1 st. on the right side. Continue knitting in Stockinette stitch. ON EACH SIDE, FULL FASHION INCREASE, 1 st. every 4th row 14x. After Row 80, ON EACH SIDE, FULL FASHION DECREASE, 1 st. every 2nd row 5x, 1 st. every 3rd row 5x, 1 st. every 2nd row 15x. After Row 134, remove the sts. onto waste yarn.

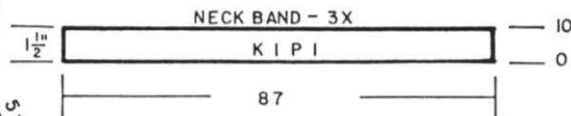

NECKBAND: MAKE 3.

Cast on 87 sts. and work 10 rows K1, P1, Ribbing. Transfer the ribber sts. to main machine, knit 1 row stockinette stitch then remove the sts. onto contrast waste yarn.

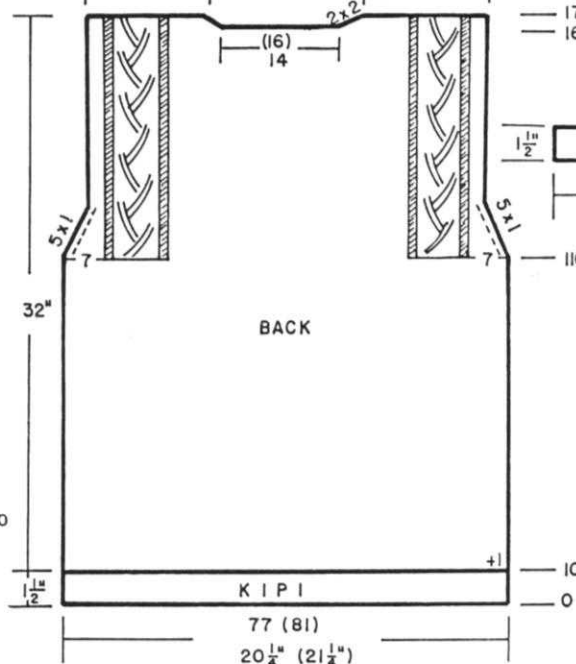

FINISHING: See General Instructions. Sew down pocket lining on the inside. Fold one section of band in half and center it on back of neck and pin in place evenly. Attach one band to one side of Jacket and other band to other side matching the edgws of first band. Weave the open sts. to edges of Jacket.

KNITTING NEWS



VOLUME 20, No. 2

PRACTICAL KNITTING HINTS

MAKING SHORT ROWS WHEN USING THE RIBBER
For example - 506 in this issue.

The front bands for 506 are made using short rows so as to form a SHAWL COLLAR. The following is the way we knitted the bands.

101 (109) stitches are the first to be put into holding position. Transfer the ribber sts. to the main machine. With a Ravel Cord, knit these sts. by hand, pulling the sts. back to 'A' (out of work) position. Put the empty needles of ribber out of work. Be sure to place the long end of Ravel Cord BETWEEN the 2 needle beds so the cord will not catch. Knit to the LEFT side. *Bring end needle of Main Machine and end needle of Ribber to 'E' (holding) position (this is only to prevent end sts. from dropping). Knit to the right side.

Bring the required number of empty needles of main machine to 'B' (working) position to make up a group of 6 in a row. Transfer the ribber sts. to the empty needles in 'B' position and knit these 6 sts. with a Ravel Cord same as you did before, bringing the sts. back against the needle bed to 'A' position. Knit to the left side. Continue in this way, following the instructions from * until the short rows are completed.

BIND OFF IN RIBBING

In order to have an elastic bind off in Ribbing, try this... Transfer the ribber sts. to the main machine. If you are working with fine yarn, knit 1 row Stockinette stitch with Tension 10 to the left. Begin on the right, take first st. off and allow it to go behind the latch of latch tool. Remove the 2nd stitch and pull it through first stitch - however, when removing the sts. go into the knit stitch facing you from the FRONT and through the purl stitch facing you, from the BACK. If yarn you are using is not a fine yarn, work the crochet bind off holding the yarn BEHIND the Gate Pegs as you crochet with end of yarn so that the sts. will be bound off evenly and put latch tool through the FRONT of knit stitches facing you and through the BACK when purl sts. face you.

SPLIT NECKLINE AND KNIT BOTH SIDES AT THE SAME TIME WHEN USING A LACE PATTERN. Example 505 in this issue.

You CAN knit both sides and SHAPE NECK AT THE SAME TIME when knitting a Lace Pattern. Use LACE CARRIAGE FIRST. Push in the MULTI-COLOR BUTTON (MC on KNITTING and Brother machines). You will use TWO YARNS - put 1 in the MAIN ('A') Feeder and one in 'B' Feeder. Carriage is on the right side. Bring the LEFT SIDE NEEDLES for neck, to 'D' (selecting) position and carefully knit across to the left side. Bring the SAME needles (left side on garment) to 'D' (selecting) position again. LIFT THE A FEEDER YARN UP ON TOP of the selected needles. Hold this yarn gently - just enough to keep it from catching and knit to the right side. Each time you are ready to knit a row, the left side needles on machine MUST BE BROUGHT TO 'D' (selecting) position first, then knit the row. As you do this, you will shape BOTH SIDE OF THE NECK, decreasing the sts. ON EACH SIDE as per the instructions. Try it, it's fun...

YARN KITS FOR GARMENTS IN THIS ISSUE

Most of the garments in this issue of KNITTING MAGAZINE were knitted with yarn from our YARN CATALOGUE which illustrates the full range of colors available and includes actual samples. If you do not have our Catalogue, please send \$3.00 and we will mail you one immediately. You will then be able to choose your own colors.

VENETIA, our best selling yarn is not shown in the above Catalogue but we now have a Sample Card showing all the colors available. The same colors shown on the card are available in our Bulky Venetia as well. Please send \$1.00 and we will mail you a Sample Card.

FANTASIA is our newest yarn and was used with Venetia to knit the Womens Dress 501 in this issue. It is available in spools at \$7.50 per spool. A beautiful silky variegated yarn of two colors on a spool. The colors are: White is always the primary color with secondary color Pink, Aqua, Red, Sand, Light Grey, Black, then there is Beige/Light Green, Light Green/Dark Green, Yellow/White.

No. 501 - Yarn:	Venetia		
SIZES:	10/12	(14/16)	
Price:	\$32.60	\$32.60	
Shipping:	2.50	2.50	
No. 502 - Yarn:	Bulky Venetia		
SIZES:	8/10	(12/14)	
Price:	\$38.10	\$38.10	
Shipping:	2.50	2.50	
No. 503 - Yarn:	Cordella		
SIZES:	6/8	(10/12)	[14/16]
Price:	\$15.92	\$17.91	\$17.91
Shipping:	1.85	1.85	1.85
No. 504 - Yarn:	Beatrice		
SIZES:	6/8	(10/12)	[14/16]
Price:	\$31.35	\$31.35	\$37.05
Shipping:	2.50	2.50	2.50
No. 505 - Yarn:	Venetia		
SIZES:	6/8	(10/12)	[14/16]
Price:	\$43.20	\$43.20	\$43.20
Shipping:	2.50	2.50	2.50
No. 506 - Yarn:	Cordella		
SIZES:	8/10	(12/14)	
Price:	\$27.86	\$27.86	
Shipping:	2.50	2.50	
No. 507 - Yarn:	Cordella, Isabella & Angora		
SIZES:	6/8	(10/12)	[14/16]
Price:	\$32.43	\$34.42	\$36.41
Shipping:	2.50	2.50	2.50
No. 508 - Yarn:	Venetia		
SIZES:	One Size Fits All		
Price:	\$36.80		
Shipping:	3.00		
No. 509 - Yarn:	Bulky Venetia		
SIZES:	6/8	(10/12)	[14/16]
Price:	\$32.40	\$32.40	\$32.40
Shipping:	3.00	3.00	3.00
No. 510 - Yarn:	Venetia		
SIZES:	6/8	(10/12)	[14/16]
Price:	\$36.45	\$36.45	\$47.25
Shipping:	3.00	3.00	3.00
No. 511 - Yarn:	Extra		
SIZES:	40/42	(44/46)	
Price:	\$26.40	\$26.40	
Shipping:	2.50	2.50	
No. 512 - Yarn:	Regia - 3-ply		
SIZES:	38/40	(42/44)	
Price:	\$19.80	\$22.00	
Shipping:	2.50	2.50	
No. 513 - Yarn:	Venetia		
SIZES:	10 - 14	(16 - 18)	
Price:	\$24.30	\$35.10	
Shipping:	2.50	3.00	
No. 514 - Yarn:	Venetia		
SIZES:	8/10	(12/14)	
Price:	\$43.20	\$43.20	
Shipping:	3.00	3.00	
No. 515 - Yarn:	Venetia & Fantasia		
SIZES:	6/8	(10/12)	[14/16]
Price:	\$50.70	\$50.70	\$50.70
Shipping:	3.50	3.50	3.50
No. 516 - Yarn:	Venetia & Viola		
SIZES:	10/12	(14/16)	
Price:	\$60.45	\$60.45	
Shipping:	3.50	3.50	
No. 517 - Yarn:	Regia & Show		
SIZES:	6/8	(10/12)	[14/16]
Price:	\$17.85	\$20.05	\$20.05
Shipping:	2.50	2.50	2.50
No. 518 - Yarn:	Venetia & Isabella		
SIZES:	10/12	(14/16)	
Price:	\$47.60	\$47.60	
Shipping:	3.50	3.50	
No. 519 - Yarn:	Venetia		
SIZES:	8/10	(12/14)	
Price:	\$43.20	\$43.20	
Shipping:	3.00	3.00	
No. 520 - Yarn:	SPECIAL KIT YARN		
SIZES:	Medium	(Large)	
Price:	\$45.00	\$45.00	
Shipping:	4.00	4.00	



NEW, DEMONSTRATORS AND TRADED MACHINES AT GIVE AWAY PRICES...

Nobody can beat our prices, so if you want a second machine, place your order as fast as possible... Maybe you have a friend who cannot afford a brand new machine... If so, please tell her about our low, low prices... and if you want a machine not listed below, let us know... We have too many to list them all.

ALL PRICES F.O.B. LOS ANGELES - SHIPMENT VIA UPS

		<u>CONDITION</u>	<u>LIST PRICE</u>	<u>SALE PRICE</u>
<u>KNITKING</u>				
KH 910	COMPUKNIT ELECTRONIC W/Lacemaker OK for use with KG 88 Garter Carriage (Demo - New Machine Guarantee)	Like New	\$ 999.95	\$ 699.00
KH 910	COMPUKNIT ELECTRONIC W/Lacemaker - Same machine as listed above.	Very Good	999.95	599.00
KH 910	COMPUKNIT ELECTRONIC W/Lacemaker and Ribber (Demo - New Machine Guar.)	Like New	1299.90	849.00
KH 891	Punch Card Knitter W/built in Knitleader and Lacemaker. OK for use with KG 89 Garter Carriage (Demo - New Machine Guar.)	Like New	629.95	499.00
KH 891	Punch Card Knitter with Built in Knitleader Lacemaker, and Ribber (Demo - New Machine Guarantee).	Like New	929.90	649.00
KH 881	Punch Card Knitter W/built in Knitleader and Lacemaker.	Excellent	549.95	399.00
KH 881	Punch Card Knitter W/Lacemaker and Ribber	Excellent	849.90	549.00
KH 840	Punch Card Knitter W/Lacemaker	Excellent	499.95	299.00
KH 830	Punch Card Knitter W/Lacemaker	Excellent	449.95	249.00
KH 820	Punch Card Knitter W/Lacemaker	Very Good	399.95	199.00
KH 120	Fine Needle Knitter W/258 Needles and Lacemaker, Push Button Pattern Selection (Demo - New Machine Guarantee)	Like New	399.95	249.00
KH 260	New Model Bulky Punch Card Knitter (Demo - New Machine Guarantee)	Like New	599.95	499.00
KR 260	Bulky Ribber	Like New	329.95	249.95
KH 230	Bulky - (Demo)	Like New	399.95	249.00
KH 230	Bulky - With Ribber	Excellent	699.90	350.00
KH 230	Bulky Ribber	Excellent	299.95	150.00
KH 710	GENIE Push Button Pattern Selection W/Lacemaker (Demo - New Machine Guar.)	Like New	299.50	199.00
KH 710	GENIE Push Button Pattern Selection W/Lacemaker and Ribber (New Machine Guar.)	Like New	579.00	375.00
S 120	JUMBO GENIE with built-in Intarsia (Demo - New Machine Guarantee)	Like New	299.95	175.00
R 120	JUMBO GENIE Ribber (Also fits S 140)	Excellent	279.95	175.00
<u>BROTHER</u>				
KH 910	ELECTROKNIT- With Latest PC Unit	Very Good	995.00	599.00
KH 588	Push Button Pattern Selection W/Lacemaker	Excellent		125.00
KH 800	12 Stitch Punchcard W/Lacemaker	Very Good		125.00
KH 551	Push Button Pattern Selection	Very Good		75.00
<u>GARTER CARRIAGES</u>				
KG 88	Garter Carriage for KH 910, KH 881, 860 (Demo - New Machine Guarantee)	Like New	299.95	249.00
KG 89	Garter Carriage for KH 891, 890 (Demo - New Machine Guarantee)	Like New	289.95	249.00
<u>SINGER/STUDIO</u>				
SK 360	Punch Card Knitter	Excellent	529.95	349.00
SK 500	Computerized Electronic	Excellent	950.00	399.00
Mod 150	Chunky Knitter	Like New	337.95	229.00
SR 150	Chunky Ribber	Like New	319.95	199.00
SRP 50	Ribber - Fits 328/360/500/560	Excellent	279.95	199.00
MK 70	Lecler - Folding Portable Knitter	Excellent	379.95	185.00
SK 312	Punch Card Knitter	Very Good	349.95	125.00
SK 322	Punch Card Knitter	Very Good	399.95	150.00
SK 303	Knitter and Ribber	Very Good		150.00
<u>TOYOTA</u>				
KS 727	Punch Card Knitter	Excellent		125.00
<u>JUKI</u>				
2400	Punch Card Knitter	Excellent		150.00



506

IMPORTANT

Color stripes in a Slip (or Skip) Pattern for a Jacket are quickly knitted if you use your Color Changer. The Jacket has wide front bands that form a Shawl Collar. Use Cordella and knit it in sizes 8 to 14.





502

LIGHTNING

flashes across the front of this lovely Pullover. You can knit it with our bulky Venetia on any bulky machine. The lightning is Angora and the Intarsia Carriage makes knitting a breeze. Sew on beads for additional accent. Sizes 8 to 14.



CREATIVE

Brilliant colors combine with Angora triangles to make up a fun to knit Pullover that you will wear and wear...

It's made using Short Rows with our own Venetia and Angora yarn in sizes 10 to 16.





SPORTY

He'll really go for this great zip Jacket. It is quickly knitted on any bulky machine using the short row method. Three colors of Extra blend to form triangles. Ribbing is used for the bands. Sizes 40 to 46.



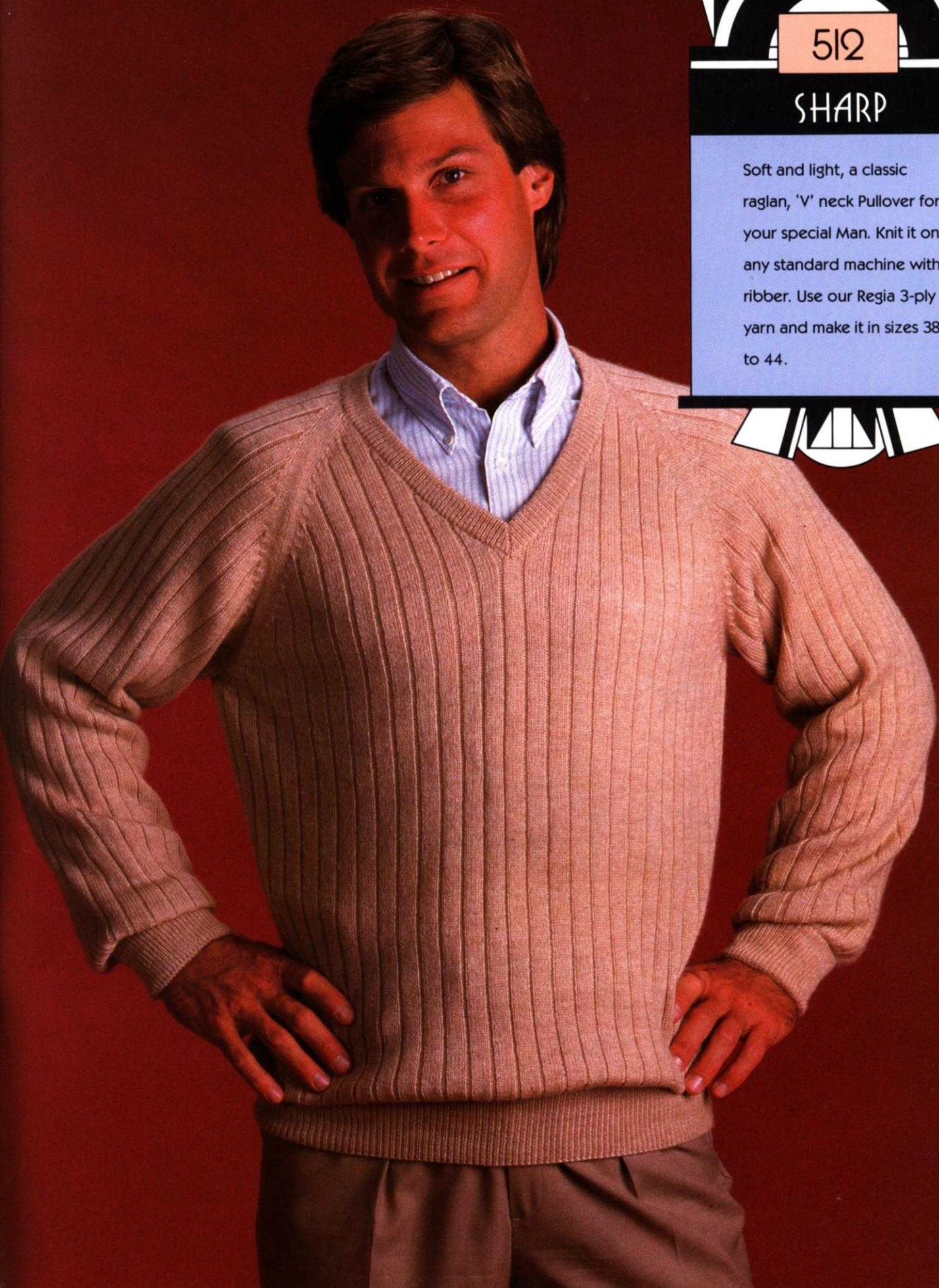

512

SHARP

Soft and light, a classic raglan, 'V' neck Pullover for your special Man. Knit it on any standard machine with ribber. Use our Regia 3-ply yarn and make it in sizes 38 to 44.



519

ARTFUL

A beautiful Lace Top has a scoop neckline and ribbed waistband. The skirt is a full needle ribbing Pattern with tension changes for a perfect fit. Knit it with Venetia in sizes 8 to 14.





508

RUANA

A light and airy Cover Up can be knitted quickly on any machine. Out of work needles form the pattern. The long knotted fringe with beads adds the glamour. One size fits all. Venetia is the yarn.



JUMBO Genie

"the magic knitter"

JUMBO GENIE IS A
BULKY BEST BUY...check
its price and versatility
against other brand
bulky knitters.

It's a full size, 120 plated steel needles (8mm spacing) knitter that is just perfect for knitting 4 ply worsted weight yarn. Its range is from sport weight to jumbo yarn... Mohair, Angora, Nubby, Boucle, etc., etc....it knits them all.

The JUMBO GENIE has Intarsia and Tuck Knitting Controls built into the carriage. You pay extra for Intarsia knitting on some other machines. A row counter, kit of tools and instruction manual is standard with every machine and the JUMBO GENIE knitter weighs 20 lbs.

The JUMBO GENIE has an all hardened steel (not plastic) needle bed for continuous smooth operation. Twin overhead adjustable yarn feeders and easily adjusted tension control for different weights of yarn.

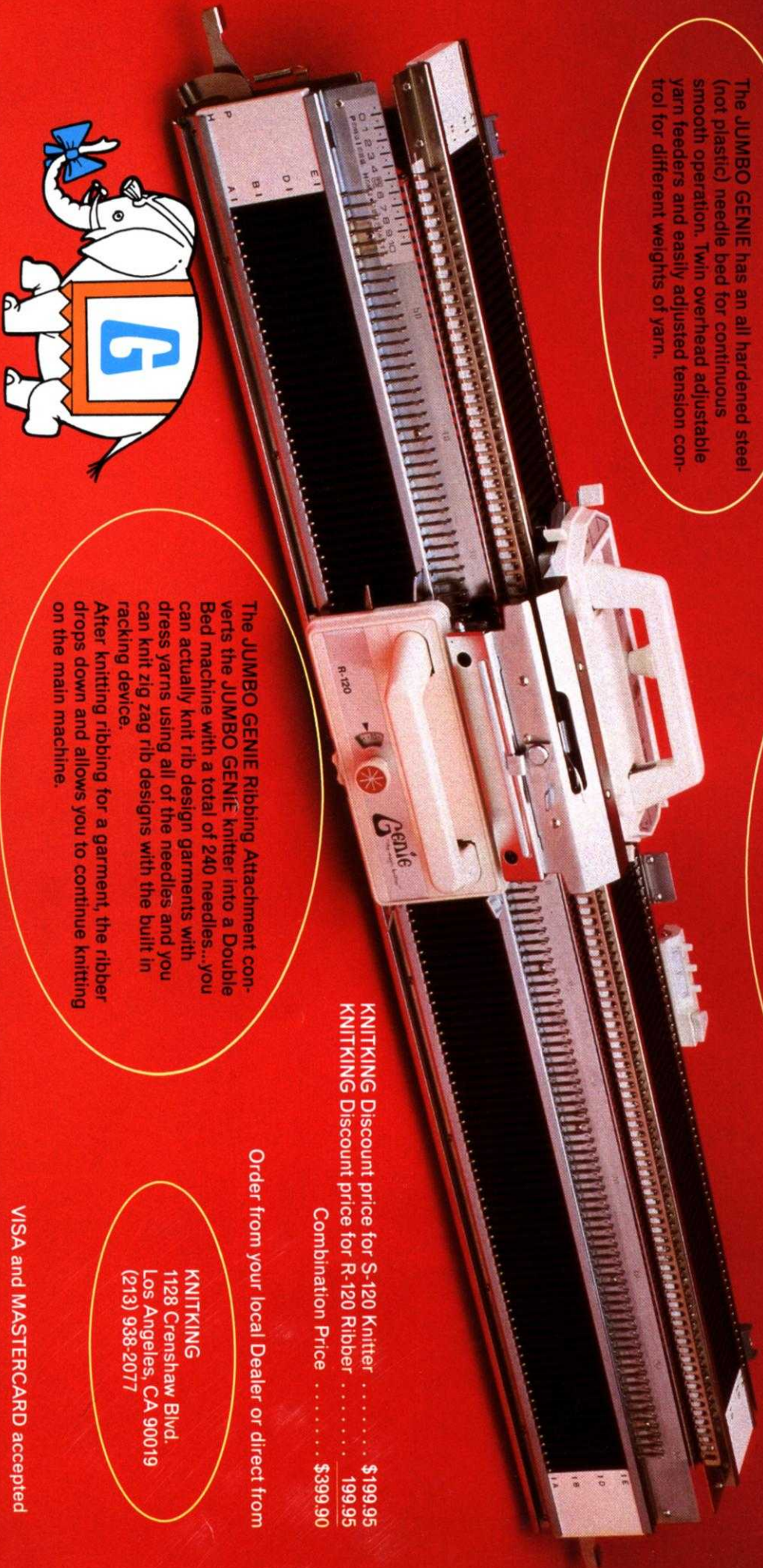

The JUMBO GENIE Ribbing Attachment converts the JUMBO GENIE knitter into a Double Bed machine with a total of 240 needles...you can actually knit rib design garments with dress yarns using all of the needles and you can knit zig zag rib designs with the built in racking device.
After knitting ribbing for a garment, the ribber drops down and allows you to continue knitting on the main machine.

KNITTING Discount price for S-120 Knitter \$199.95
KNITTING Discount price for R-120 Ribber 199.95

Combination Price \$399.90

Order from your local Dealer or direct from

KNITTING
1128 Crenshaw Blvd.
Los Angeles, CA 90019
(213) 938-2077

VISA and MASTERCARD accepted



520

COZY

Any bulky machine with ribber can make this warm and fashionable Jacket. It is made with a Kit yarn, plied for bulk. Cables accent the shoulders and armhole. The deep pockets are simply great. Special purchase Tweed Yarn. Sizes Medium and Large.

KNITKING Punch Card Programmed Bulky

The very latest and easily the most versatile of all Bulky knitting machines. It's the first with automatic PUNCH CARD PATTERN selection and it knits a range of yarns from sport weight to jumbo, including Angora, Mohair, Bouclé, Ribbon, Cotton, Acrylic, etc. The KNITKING KH 260 has 114 stainless steel needles in a needle bed 40" wide. At 3 stitches per inch, it knits up to 38" wide. The Tension Control Dial has 30 tensions for knitting different weights of yarn... Comes complete with TWIN OVERHEAD FEEDERS, 15 PRE-PUNCHED PATTERN CARDS, ROW COUNTER, complete TOOL KIT, STITCH MEASURE SCALES for Knitter, CARRYING CASE, a detailed, well illustrated, easy to understand INSTRUCTION MANUAL and a one year warranty on parts and service.

Accepts standard 24 stitch Punch Cards for:

- Fair Isle Patterns
- Weaving
- Skip Stitch and Tuck Stitch
- Automatic Plating
- Tread Lace
- Isolation Motifs

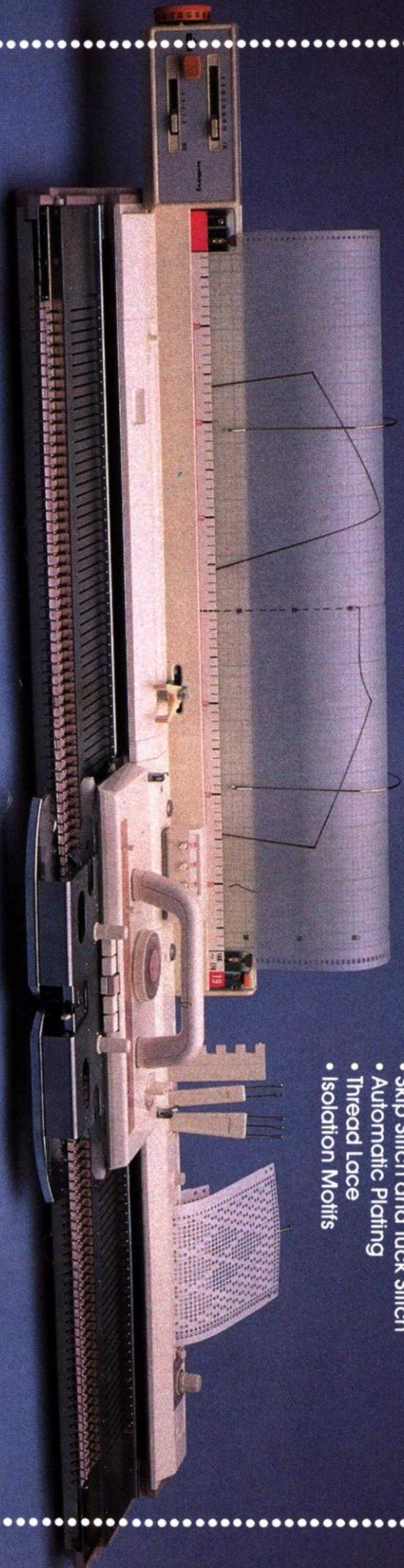

Order from your local Dealer or direct from:
KNITKING CORPORATION — 1128 Crenshaw Blvd.,

Los Angeles, CA 90019 Telephone: (213) 938-2077

Model KH 260



503

SIESTA

Isolate this delightful design on a flattering Tunic. Bands of color on the sleeves and lower edge tie it all together. Knit it on any Electronic machine using Cordella yarn. Sizes 8 to 14.



COMPUKNIT KH 910

'the world's finest knitting machine'

- Incredibly versatile... Anything you can trace or draw is automatically reproduced in your knitting in the colors and yarns of your choice.
- Simple to program and easy to operate, the COMPUKNIT KH 910 is the 'State of the Art' in home knitting machines. It is the only knitter made that has a memory unit to retain your program if you suffer a power outage or wish to move your knitter from one place to another.
- The maximum width of motif or pattern design possible on any punch card machine is 30 stitches (the standard is 24). The COMPUKNIT has no limit. It is possible to knit a single picture or lace design over the full width (200) needles of the needle bed. It will, in fact, do everything that's possible on a punch card machine and much much more.
- If you already own a knitting machine, you must consider trading up to a fantastic COMPUKNIT 910. If you have never owned a knitter before, start at the top and save money and save all the intermediate steps.



Order from your local Dealer or direct from
VISA and MASTERCARD accepted

KNITTING

1128 Crenshaw Blvd.
Los Angeles, CA 90019
Telephone: (213) 938-2077