

VOL. 20 #1 Norma



knitking
magazine



**HOLIDAY
HAPPENINGS!**
Our Christmas issue
is loaded with Good
Cheer & Great Gifts!

495



Color Blaze

Designed with you in mind, a one piece bright Dress has a Lace Pattern on the diagonal at the top of the bodice and across the Skirt section. Repeat the Lace across lower edge of Sleeves. Venetia is the yarn and you can knit it in Sizes 6 to 12.



486



Stunning

All eyes will turn toward you when you wear this softly shaped two-piece Dress. The Rose Lace Design is isolated at neck and shoulder and repeated at lower edge of paneled Skirt. It is knitted on the KH 910 Electronic machine in Sizes 6 to 16. Venetia is the yarn.



Volume 20 No. 1

481— Women's Pullover	13
482— Women's Skirt & Top	14
483— Teens Turtle Neck Pullover	16
484— Women's Basket Weave Pullover	18
485— Women's Pullover	19
486— Women's Two Piece Dress	21
487— Women's Two Piece Dress with Shawl ..	24
488— Women's Two Piece Dress	26
489— Women's Pullover	28
490— Women's Two Piece Dress	29
491— Women's Pullover	32
492— Women's Two Piece Dress	33
493— Women's Pullover	35
494— Women's Two Piece Dress	36
495— Women's Dress	38
496— Men's Pullover	40
497— Men's Pullover	41
498— Bear Pullover	42
499— Baby Cardigan	43
500— Baby Cardigan	44
Doll Ornaments	45
Pot Pourri Christmas Ornaments	46
Christmas Wall Hanging	47
Knitking News	49

Fifty two gallons of coffee and two thousand nine hundred and eighty doughnuts were consumed during the week of the annual KNITKING Seminar and Open House.

"It's been great..." "The best ever..." "Everybody at KNITKING has been wonderful..." "The Teachers have been outstanding..." "There are no other Seminars like KNITKING SEMINARS..." All these comments and more were volunteered by visitors from throughout the U.S.A. and as far away as England, Australia and Canada before leaving for their homes.

It was indeed a great Seminar. In addition to our resident experts, we benefited tremendously from classes conducted by Mary Louise Norman, Sara Brooks, Tami Nobuyuki and especially Yukiko Mitsumata of Brother Industries who is possibly the greatest all around knitting machine teacher in the world. She in fact travels the world demonstrating her expertise in many countries.

Our substantial premises have been strained in previous years by the numbers of visitors so this year we erected a large 100 seat tent on our parking lot. This in addition to our main 100 seat classroom and 2 additional classrooms was filled to capacity on many occasions. On Wednesday the 18th of September more than 400 visitors entered our premises. The Knitting Machine Owners Guild of San Diego chartered a bus for the day and on their own admission had a great time.

As is usual at KNITKING Seminars, there was no charge for admission or refreshments and we gave away \$800.00 in prizes to participants in our Fashion Show and Knitting Contest.

It will be difficult to top the 1985 Seminar in 1986 but we will do our best—so plan now to be with us then. The provisional starting date is September 14th, 1986.

THIS SPECIAL CHRISTMAS ISSUE

We think this issue is one of our great ones. Every garment is outstanding. The design Staff and knitters outdid themselves despite great pressure from your Editor to get the issue out early.

Joann Waddell is the female Model. We had so many letters in praise of her work in Volume 19 Number 3, we asked her to do this Special Christmas issue. The handsome male Model is Ted Richards, an Actor used frequently in television commercials. The good looking male teenager is Benjamin Madera, son of Jessica Madera, one of our KNITKING MAGAZINE Designers. Jennifer the baby is the granddaughter of Eva Eisenstein who designs and knits garments for KNITKING MAGAZINE. Jennifer would not stand still for the photographers so we photographed her with Joann for two charming pictures. Dorothy Gallagher of Oswego, New York made the cute Teddy Bear Sweater especially for KNITKING MAGAZINE. The beautiful Wall Hangings shown in the photographs were designed and made by Shizue Nakamura, head of the Design department for KNITKING MAGAZINE.

KNITKING extends the compliments of the season to all of its friends and we look forward to 1986 with great enthusiasm...See you then.



Cover Model



Bunny Soft

Love the feel of Angora?...
Knit this two-piece Dress with the Sleeves and flattering Collar using Angora. Venetia with Mami Rex knitted together for sparkle. The isolated panel is elegant Thread Lace...The flip flounce skirt is made with Short Rows and knitted sideways on the machine.
Sizes 8 to 14.

481

Sophisticate...

Bright lace has a place in your life for holiday activities. You can knit this lovely Pullover using a Garter Carriage for the garter stitch stripes on the sleeves. Knitted with Regia in Sizes 4 to 14.



487



Holiday Glamour

A lovely three-piece ensemble will take you through all day into night for any holiday adventure. Isolated inserts at neck and on the sleeves with Angora overlay trim... A triangle Shawl boasts feathers with beads for added evening glamour. Knit it with Venetia and Angora in Sizes 8 to 14.



482

Casually
Elegant

A two piece Dress in
easy Stockinette stitch.

You'll love the
swinging flare of the
Skirt that is knitted
sideways on the
machine using Short
Rows. A softly rolled
Collar frames a pretty
face. The yarn is Show,
the Sizes 4 to 14.





497



Ship Ahoy...!

A new Rib Design
fashions a boat neck
Pullover for that
special Man in your
life. He'll happily wear
it often and make
you happy too. Knit it
with Beatrice in Sizes
40 to 46.

489



*New York...
New York...!*

The New York Skyline is always a thrilling sight and you can knit this Pullover with the old yellow Moon shining down approvingly... Intarsia method for the Design, and Stockinette stitch with ribbed Bands for back and sleeves. Knit it with Amore. Sizes 6 to 16.



492



A
Perfect
Beauty...

A swirling Paisley Design (fashions newest craze) is on the front section of an elegant Pullover. Special instructions are given for the Short Rows to make it easy for you. Soft Angora makes the sleeves. Knit the Skirt in Stockinette stitch. We used Venetia, Mami Rex and Angora. Sizes 6 to 16.



494

Spectacular

An outstanding two-piece sparkling Dress to wear for all happy occasions. A lush Paisley Design for front and back panels of top and for the Skirt. Knit it with Venetia and Mami Rex on any Electronic machine. Sizes 8 to 14.

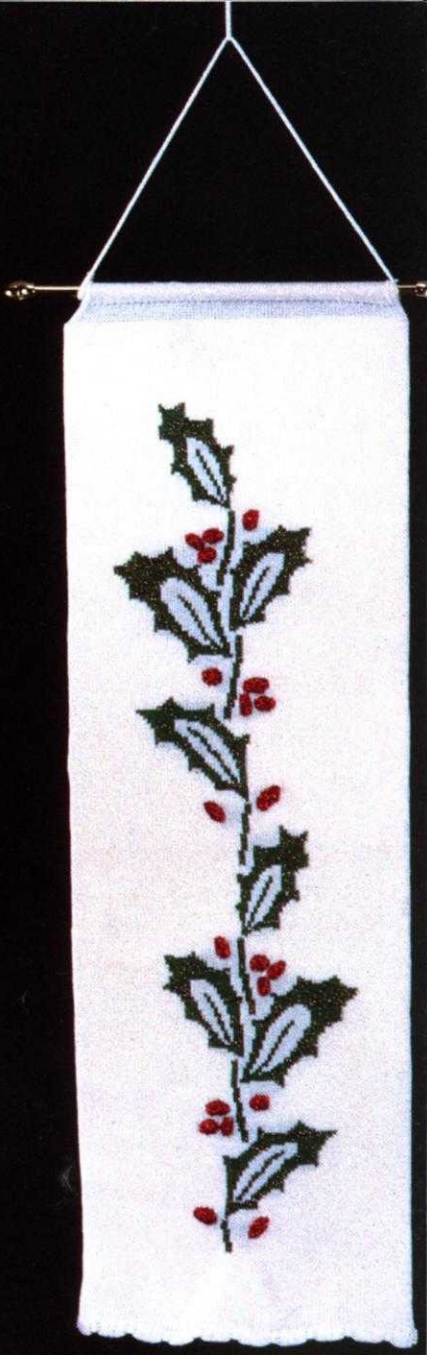

498

Beary Nice

A big Bear needs his own Bear Pullover and all Children will be ecstatic if you knit this one, Bear Size 22" to 24."

493

Merry Christmas

A beautiful quick to knit Pullover is knitted sideways on the Bulky machine using our new Bulky Venetia. Crochet the ruffled Collar with Angora. Crochet the ruffled Collar with Angora. (Instructions for the Bell and Ball trims are in this issue.)
Sizes 8 to 14.



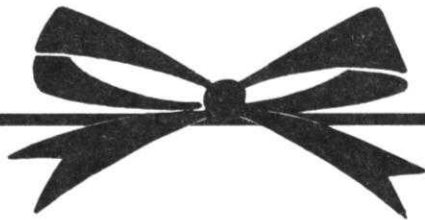

THE PRINTED INSTRUCTIONS

Follow the printed instructions or use them in combination with the Charts. Where there is any question in the instructions, you have the Charts to show you how the section will look.

Be sure to READ AHEAD so that you KNOW what to do for the size you are knitting. In the shapings, where the number of stitches are the same but the number of times different, you might find shapings like this...3 sts. 1 x (2x) [3x]—so that for the first size you will bind off 3 sts. 1x, 2nd size 3 sts. 2x, 3rd size 3 sts. 3x. Sometimes the ROWS will be different for each size—so you must watch out for different row numbers.

Shoulder and neck shapings for the back section of a garment usually are shaped at the same time—so ALWAYS WATCH for the words AT THE SAME TIME.

HOLDING STITCHES ON THE LEFT SIDE WHILE SHAPING THE RIGHT SIDE

There are different ways to hold stitches on one side while completing the other side. Usually, we tell you to bind off the center sts. for neck and put the left side into holding position while completing the right side. The easiest way and really the best way for beginners is to take a piece of RAVEL CORD and hand knit the center neck stitches, pulling them back against the needle bed of machine to the "A" or out of work position. The stitches remain in the HOOKS of the needles so you are really only knitting them HALF WAY. With another color of Ravel Cord, knit the remaining sts. on the left side in the SAME WAY.

It is important to protect these held stitches in some way—so you can either hang a REVERSING BAR so that the EYES of the Bar go BETWEEN the Gate Pegs on the machine and that the UPPER TIPS of Bar only—show above the needle bed...OR the simplest way is to use a piece of 1 inch masking tape and GENTLY place it beneath the knitting—right below the gate pegs. Do NOT press the tape—only enough pressure to hold it in place. This will prevent the Carriage (or Slide) from marking the held section.

It is VERY IMPORTANT that you mark the PATTERN ROW where you divide for the split for NECK (or SHOULDER) shaping....If you are using a PUNCH CARD—MARK THE CARD—if you are using an ELECTRONIC machine, MARK THE DESIGN WINDOW. Also take note of the Row number for the division. When you are ready to work the left section, bring the HELD stitches back to B (working) position by pulling each end of the Ravel Cord GENTLY and rip it off—be sure to align all needles straight in the B or knitting position.

Now you are ready to REFER TO YOUR OWN INSTRUCTION MANUAL for your machine—to set the controls to begin knitting the left half. The neck stitches can be bound off after completing the right side or you can leave them in hold until each side is finished, then bind them off or remove them onto contrast waste yarn ready to be picked up for knitting a neckband or for other finishing.

FULL FASHION DECREASING OR INCREASING

For Stockinette stitch, use the Full Fashion method for decreasing or increasing (except for regular cap shaping on sleeves where you decrease the edge stitch).

TO DECREASE: Hang the 3rd stitch onto the 2nd stitch then move the end stitches in to fill the empty needle.

TO INCREASE: Move the 2nd end stitches 1 needle outward, then pick up the 3rd stitch from the row below and hang it onto empty needle.

PATTERN SYMBOLS

() Symbol for 2nd size.

[] Symbol for 3rd size.

There are up to 3 sizes given for Patterns in KNITTING MAGAZINE. For example, the Charts and printed instructions will show the cast-on as...124—First size. (132)—Second size. [140]—Third size.

R = ROW

☐ Needles in holding position.

☒ Needles back into working position.

< For Short Row Knitting

THE SAMPLE SWATCH

Before you knit any garment, you must knit a sample swatch using the yarn you have chosen for your garment. If you do not get the correct Stitch and Row Gauge as given for a Pattern in KNITTING MAGAZINE—try different tensions. If you are using the specified yarn, you should be able to get the correct gauge using one of the tensions shown. If you are using other yarns, you may have to make several swatches—but the gauge is very important.

To make a sample swatch—Cast on 60 stitches with waste yarn and knit 6 rows. Mark the tension number for your sample swatch by making holes (you can do this with a Lace Carriage or by hand), 4 transfers for Tension 4, 6 transfers for Tension 6, etc. Knit 6 more rows.

Change to garment yarn and set Counter at 0. Knit 30 rows (in Stockinette stitch or Pattern stitch—according to the garment). With contrast waste yarn knit the 10th stitch FROM EACH SIDE—by hand. Knit 30 rows. Change to waste yarn and knit 12 rows. Remove the sts. from the machine by pushing the Carriage (or Slide) across without yarn.

Pull and stretch the sample swatch both lengthwise and diagonally from corner to corner, then lengthwise again. Gently block the swatch (KNITTING PRESSING CLOTHS are great for this)—or you can allow the sample to rest several hours or even over night so that the stitches can return to their basic form. USE KNITTING CONVERTA TAPE for MEASURING YOUR SAMPLE (or the KNITTING INSTANT STITCH AND ROW GAUGE MEASURE).

If you use the Converta Tape, pull out the Tape to measure BETWEEN the 40 marked stitches in the center of your swatch. Move the red marker on the Tape so that it points to 40 stitches on the TAPE. Your stitch gauge to 2" (5 cm) will show in the RED WINDOW. To find the number of rows in 2" (5 cm), place the

Tape to measure over the 60 rows, push the red marker to 60 on the Tape and your row gauge for 2" (5 cm) will show in the red window.

If you do not own a KNITTING CONVERTA TAPE or a Stitch and Row Measure, you must count the number of stitches and rows to 2" (5 cm) after marking a 2-inch square in the center of your knitting.

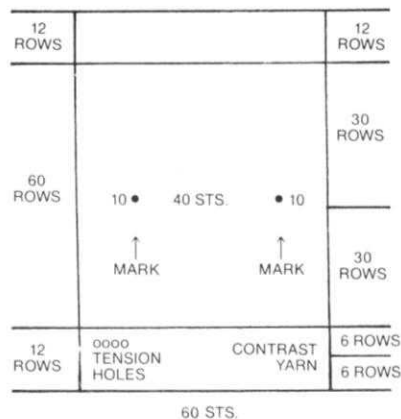

FINISHING

Gently block all sections—For PULLOVERS, JACKETS and DRESSES: Join the front to back at shoulders and sides. Sew sleeves together and set in. Hem lower edge and sleeve edges if needed. For a double neckband or armhole, band sew 1 edge to inside and 1 to the outside of neck or armhole. For a single ribbed band, sew 1 edge to the outside of neck or armhole edge. For a cardigan or jacket with buttonholes, finish buttonholes and sew on buttons.

PANTS: Join front to back at sides. Sew inside leg seams, then join to center front and back. Make hem at waistline and insert elastic. Hem lower edge of pants' legs.



☑ Needle not used—in out of work position.

3x1

☐ The number in the box is the number of Rows between shapings. The 3 x 1 above the box gives you the sts. and number of times to make the decreases (or increases)—FOR EXAMPLE: 3 x 1 over the box with 4 means—At the given Row number, *decrease 1 st. knit 4 rows* and REPEAT from * to * 2 times more for a total of 3 times in all. All decreasing (or increasing) WITHOUT ROW NUMBER IN BOX must be made on EVERY 2nd ROW.

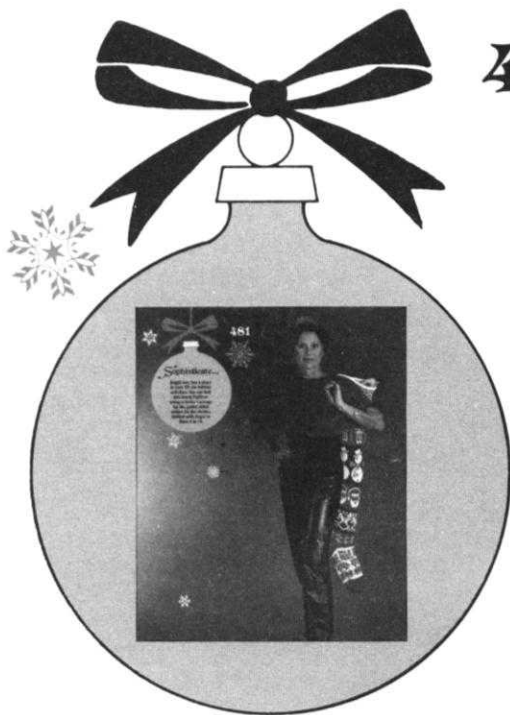

Bring the needles on the left into working position, put Counter back to 130 (140) [150] and complete the left half. Follow the instructions from *.

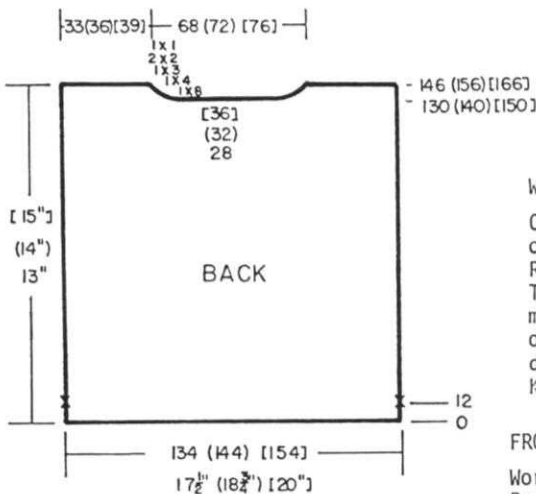
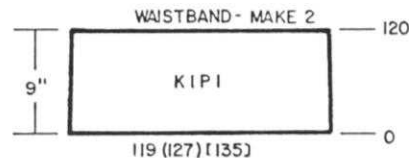

WAISTBAND: Make 2.
Cast on 119 (127) [135] sts. with color 2 and work 120 rows K1, P1 Ribbing. Transfer the ribber sts. to main machine then hang the open sts. of waist onto these needles, doubling every 8th and 9th st. Knit 1 row then bind off LOOSELY.

FRONT:
Work the front the same as the back to Row 126 (134) [142]. Bind off the center 28 (32) [36] sts. put the needles on the left into holding position (A) same as you did for back and complete the right side first.
*ON NECK SIDE, bind off 6 sts. 1x, 4 sts. 1x, 2 sts. 3x, 1 st. 4x. After Row 146 (156) [166], bind off the remaining sts. Mark Card. Bring the needles on the left into working position, turn Row Counter back to 126 (134) [142] and complete the left half. Follow the instructions from *.

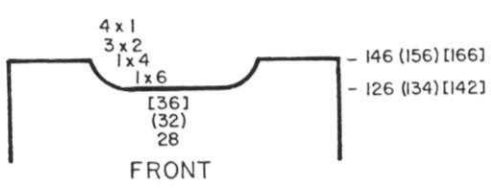

NECKBAND: Make 1.
Close 1 shoulder. With color 1, cast on 143 (153) [163] sts. and work 14 rows K1, P1 Ribbing. Transfer the ribber sts. to main machine then pick up sts. around neck. Bind off LOOSELY. Close open shoulder and band.

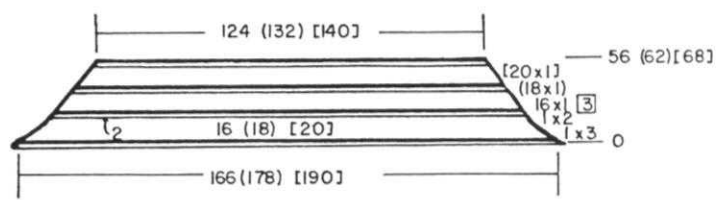
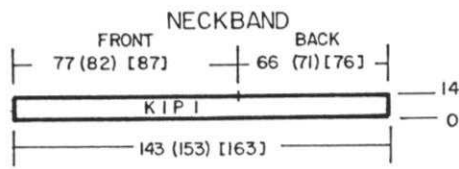

SLEEVES: Make 2.
With contrast waste yarn, cast on 166 (178) [190] sts. Knit 9 to 11 rows then 1 row Ravel Cord to the right side. Counter at 0. With color 2, work 2 rows Garter Stitch. Change to color 1 and Stockinette stitch. ON EACH SIDE, bind off 3 sts. 1x, 2 sts. 1x, AT THE SAME TIME ALWAYS KNIT 16 (18) [20] ROWS STOCKINETTE STITCH BETWEEN each set of 2 rows Garter Stitch with color 2.

ON EACH SIDE, decrease 1 st. every 3rd row 16 (18) [20]x (see Chart). After Row 56 (62) [68], remove the sts. onto contrast waste yarn.
FINISHING: See General Instructions. Weave the open sts. of sleeves to marked sides. Work single crochet with color 2 around sleeve edges doubling every 2nd stitch.

WOMENS PULLOVER
SIZES: 4/6 (8/10) [12/14]
YARN: Regia
AMOUNT:
color 1 4 5 5 balls
color 2 2 2 2 balls
TENSION: Lace - Tension 6
Stock: Tension 6.1
Ribber - 1/1
GAUGE: 15 sts. 22 rows = 2" (5 cm)

Made on the KH 891 with Ribber and GARTER CARRIAGE KG 88. The KG 88 is used for the 2 rows of garter stitch stripes on the sleeves. If you do not own a KG 88 Garter Carriage, you can make these rows in Stockinette stitch using two strands of yarn. Waistband is K1, P1 Ribbing. Punch Card for LACE Design. There are no instructions for the large Christmas Stocking. It was given to us. However, if you want to design and knit one, the Punch Cards are available from The Knittery, Box 616, Walker, MN 56484.

BACK:
With contrast waste yarn, cast on 134 (144) [154] sts. After knitting 9 to 11 rows, knit 1 row with Ravel Cord to the right side. Change to color 1 and put Counter at 0. Work in Lace Pattern with Tension 6. After Row 12, mark each side with bit of contrast yarn for setting in sleeves. Continue in Lace to Row 130 (140) [150]. Bind off the center 28 (32) [36] sts. Put the needles on the left into holding position (on ravel cord to A position) and complete the right side first. (Mark Card). *ON NECK SIDE, bind off 8 sts. 1x, 4 sts. 1x, 3 sts. 1x, 2 sts. 2x, 1 st. 1x. After Row 146 (156) [166], bind off the remaining sts.

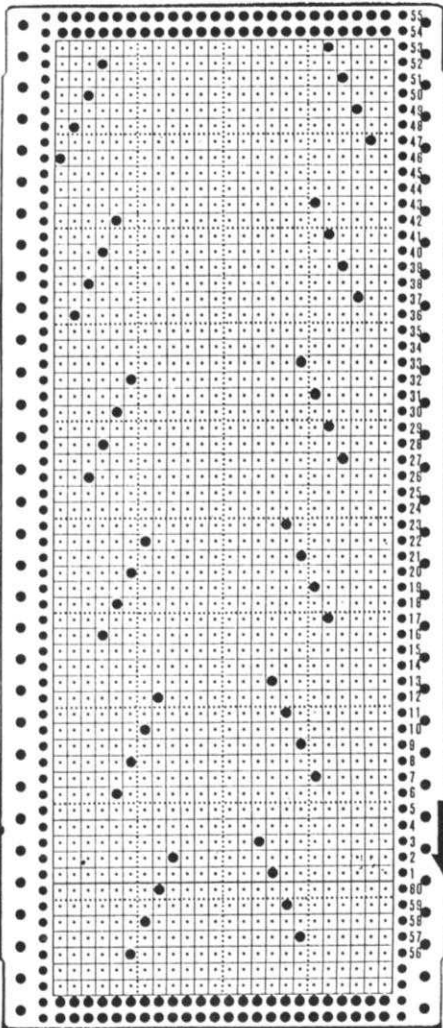

PULLOVER BACK:

Cast on FULL NEEDLE RIBBING - 132 (146) [160] sts. ON EACH BED. SET RIBBER AS FOLLOWS:
 Left PR DOWN, RIGHT PR UP
 Left and right KR Change Knobs turned to the OUTSIDE.
 Slide Lever on II
 ON MAIN MACHINE, push in LEFT PART BUTTON.
 Knit 18 rows then transfer the ribber sts. to main machine (2 sts. on each needle).
 Release Part Button.
 Continue in Stockinette stitch.
 After Row 152 mark each side for setting in sleeves.

Knit to Row 292 (302) [312]. Bind off the center 20 (26) [32] sts., put the needles on the left into holding position and complete the right side first.
 *SHAPE SHOULDER AND NECK AT THE SAME TIME.
 FOR SHOULDER, bind off 5 sts. 6x, 4 sts. 1x (6 sts. 3x, 5 sts. 4x) [6 sts. 3x, 5 sts. 4x]
 FOR NECK, bind off 8 sts. 1x, 5 sts. 1x, 3 sts. 2x, 1 st. 3x.
 Bring the needles on the left into working position, knit 1 row to the left side, turn the Row Counter back to 292 (302) [312] and complete the left half. Follow the instructions from *.

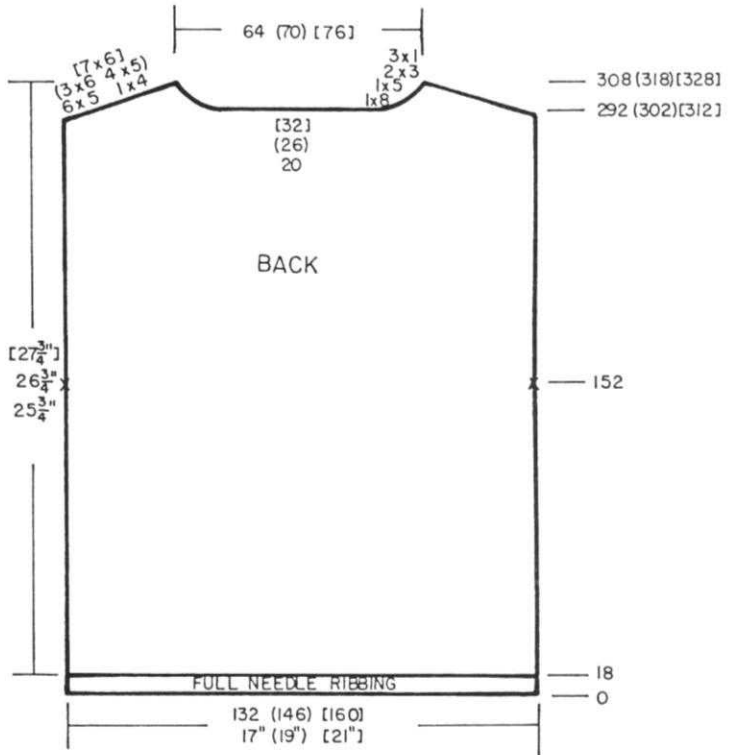

482

WOMENS DOLMAN SLEEVE PULLOVER & SKIRT

SIZES: 4/6 (8/10) [12/14]
 YARN: Show
 AMOUNT: 11 12 13 balls
 TENSION: 5 Ribber 1/1 I
 GAUGE: 15 sts. 22 rows = 2" (5 cm)
 Skirt: 14 sts. 22 rows = 2" (5 cm)

Stockinette stitch with SPECIAL CIRCULAR RIBBING for cast on bands at edges of TOP. Skirt is Stockinette stitch with Short Rows.

PULLOVER FRONT:

Work the front the same as the back to Row 280 (290) [300]. Bind off the center 8 (14) [20] sts., put the needles on the left into holding position and complete the right side first.
 *ON NECK SIDE, bind off (watch for SHOULDER SHAPING) - 7 sts. 1x, 5 sts. 1x, 3 sts. 1x, 2 sts. 3x, 1 st. 6x, 1 st. every 4th row 1x
 AND AT THE SAME TIME, after Row 292 (302) [312], SHAPE SHOULDER same as the back.
 Bring the needles on the left into working position, knit 1 row to the left side, turn the Row Counter back to 280 (290) [300] and complete the left half. Follow the instructions from *

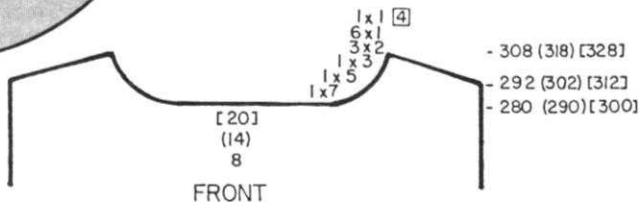
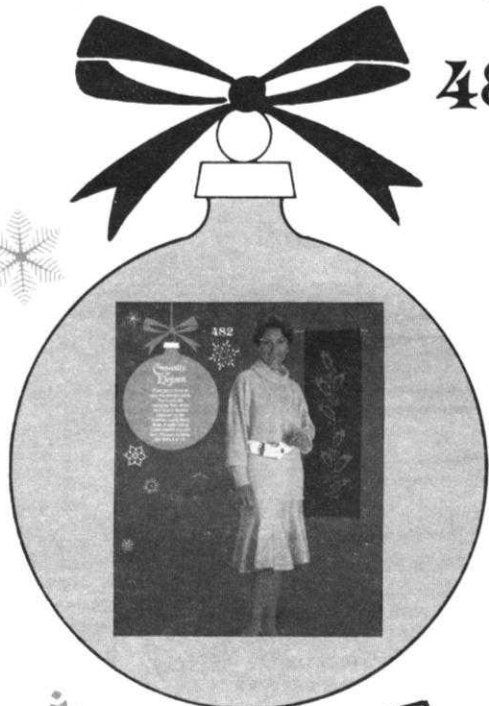

Continued

PULLOVER FINISHING:

See General Instructions. Close 2nd shoulder then sew TOP edge of sleeves together. You can slip stitch the open sts. to marked edges of arm opening - or you can hang the sections back onto the machine, knit 1 row and bind off.

RIGHT BACK	12th	A+B
	11th	A+B
	STOCKINETTE	
	40 (46) [52]	
	10th	A+B
	9th	A+B
	STOCKINETTE	
	40 (46) [52]	
	8th	A+B
	7th	A+B
	6th	A+B
WAIST FRONT OF SKIRT	5th	A+B
	STOCKINETTE	
	40 (46) [52]	
	4th	A+B
	3th	A+B
	STOCKINETTE	
	40 (46) [52]	
LEFT BACK	2nd	A+B
	1st	A+B
	16	
		180 (190) [200] 23½" (24¾") [26"]

SKIRT

OPEN CAST ON with contrast waste yarn - 180 (190) [200] sts. After knitting 9 to 11 rows, knit 1 row with ravel cord to the right side. Change to garment yarn. Do not use Row Counter. You will be working short rows and you can mark waist edge with bit of contrast yarn when you complete each section A and each section B. Knit 2 rows. A SECTION SHORT ROWS - *Leave 36 sts. on the right in working position, all other sts. in holding position.

Knit 2 rows. ALWAYS WRAP INSIDE NEEDLE IN HOLDING POSITION to prevent a hole. Push back into working position 25 sts., knit 2 rows. Push back 5 sts. and knit 2 rows. Bring 20 sts. to holding position, knit 2 rows. ALL NEEDLES IN WORK, knit 4 rows. REPEAT FROM * 2 TIMES MORE. This completes 1 section A. Now work SECTION B in the same way by FOLLOWING THE PATTERN CHART.

CONTINUE to knit the Skirt by following the SKIRT PATTERN CHART and instructions from the beginning. When 12 sections are completed, (end with 2 rows Stockinette stitch), remove the sts. onto contrast waste yarn.

SKIRT FINISHING: Press Skirt then weave the open sts. together. Fold 10 sts. at waist to the inside for casing and sew in place. Insert elastic. Turn under 5 sts. at lower edge for hem and sew in place.

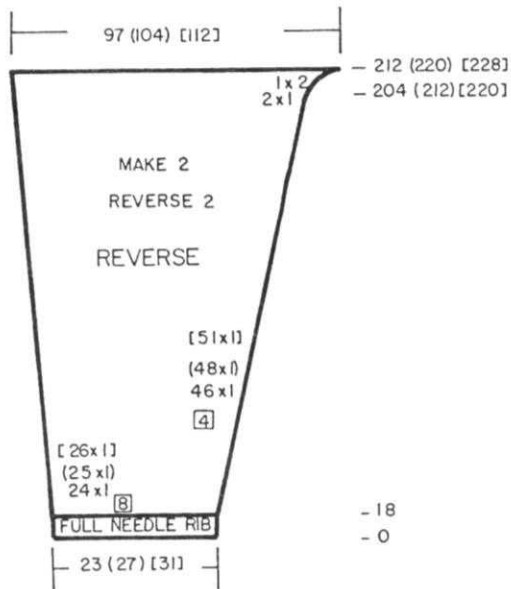

PULLOVER SLEEVES: Make 2 and reverse 2.

FULL NEEDLE RIBBING in SAME WAY as given for BACK AND FRONT. 23 (27) [31] sts. on each bed. Work the special ribbing to Row 18. Transfer the ribber sts. to main machine and continue in Stockinette stitch. ON THE LEFT, increase 1 st. every 8th row 24x (25x) [26x] AND ON THE RIGHT, increase 1 st. every 4th row 46x (48x) [51x]. After Row 204 (212) [220], on the RIGHT, increase 1 st. 2x then cast on 2 sts. 1x. After Row 212 (220) [228], Remove the sts. onto contrast waste yarn. Make another sleeve the same then make 2 with REVERSE SHAPING.

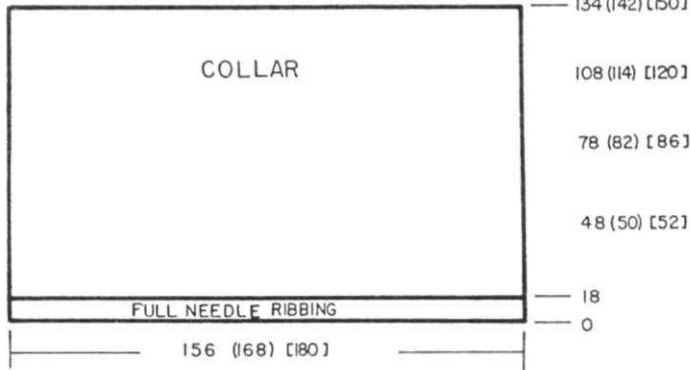

PULLOVER COLLAR: -Sew 1 shoulder. FULL NEEDLE RIBBING in same way as given for back and front. 156 (168) [180] sts. on each bed. Work the special ribbing to Row 18. Transfer the ribber sts. to main machine and continue in Stockinette stitch. Work with Tension 5 to Row 48 (50) [52], with Tension 4.1

to Row 78 (82) [86], with Tension 3.2 to Row 108 (114) [120], with Tension 3 to Row 134 (142) [150]. Sew up 1 shoulder then hang neck of garment onto the machine on top of collar. With PURL side of garment facing you, pick up sts. around neck 68 (74) [80] sts. for back and 88 (94) [100] sts. for front. Knit 1 row and bind off.

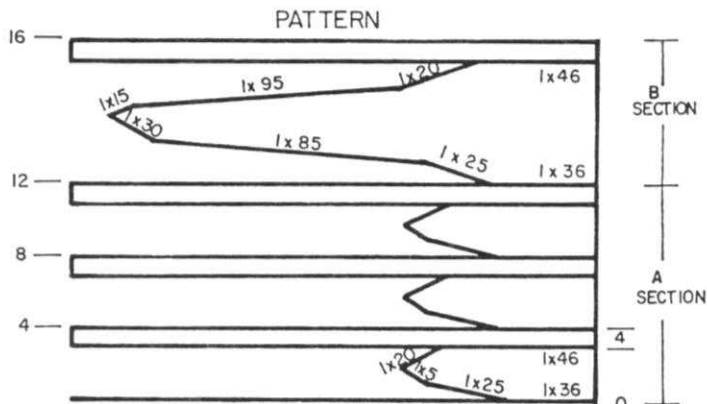

483

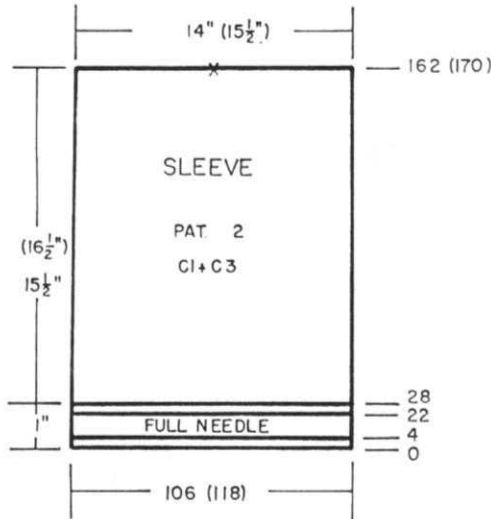
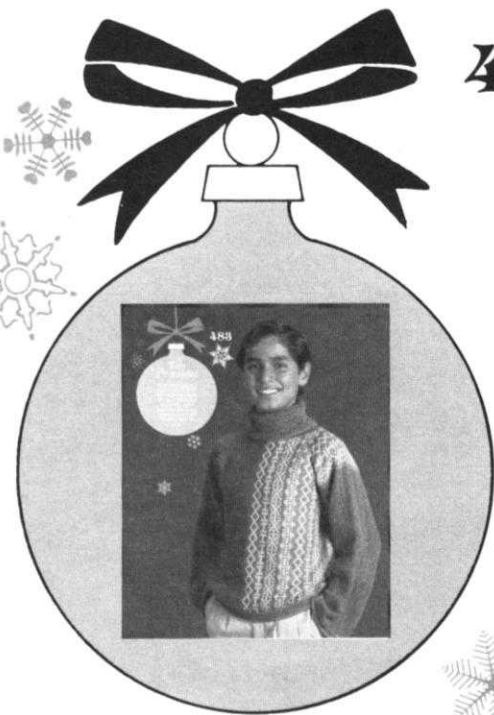

SLEEVES:

With color 1, cast on FULL NEEDLE RIBBING 106 (118) sts. COUNT THE ZIG-ZAG ROW Plus the 3 circular rows as part of ribbing. Leave the RIGHT PR Button UP AND THE LEFT PART BUTTON PUSHED IN ON MAIN MACHINE. Break yarn. READ THE SPECIAL RIBBING INSTRUCTIONS FOR MACHINE SETTINGS ON PRACTICAL KNITTING HINTS PAGE IN THIS ISSUE. Counter at 4. Turn the CHANGE KNOBS ON EACH SIDE TO THE OUTSIDE and leave them there. Knit 2 rows with color 2. With color 1, knit to Row 22. Knit 2 rows with color 2. Continue with color 1 to Row 28. Transfer the ribber sts. to main machine. Change Tension. Bring all the needles to holding (E) position and knit 1 row to the left over the doubled stitches. Set Pattern 2 on next row to the right then continue in Pattern with colors 1 and 3. After Row 162 (170) mark center stitch then remove the sts. onto contrast waste yarn.

TEENS TURTLE NECK PULLOVER

SIZES: 10/12 (14/16)
 YARN: Alpaca
 AMOUNT:
 color 1 6 balls)
 color 2 3 balls) For all sizes.
 color 3 3 balls)
 TENSION: Pat. 1 (Front) T 7
 Pat. 2 (Front and Sleeves) T 7.1
 Pat. 3 (Back) T 6.2

FULL NEEDLE RIBBING 2/2 II Sleeve Bands
 3/3 II Waistband
 GAUGE: 15 sts. 17 rows = 2" (5 cm)

Fair Isle Designs with SPECIAL CIRCULAR RIBBING (See Practical Knitting Hints this issue) Punch Cards. The Turtle Neck Collar is a varied form of 1 x 1 Ribbing.

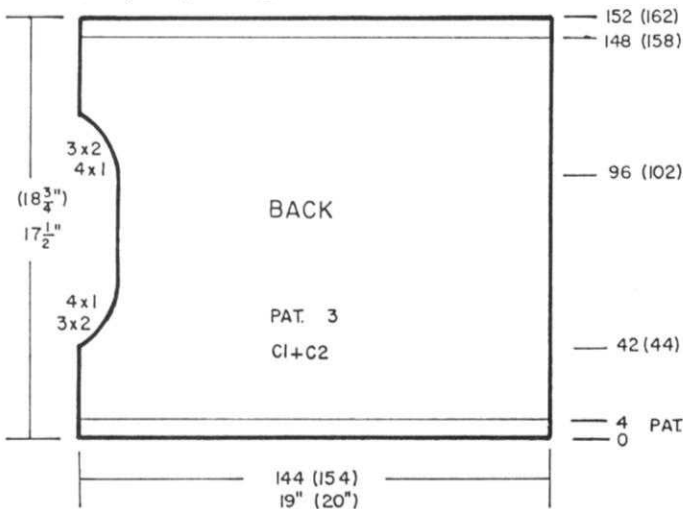

PULLOVER BACK: Pat. 3 - color 1 & 2

With contrast waste yarn, cast on 144 (154) sts. Knit 9 to 11 rows then 1 row with ravel cord to the right side. Change to color 1 and work 4 rows Stockinette stitch, setting Pattern 3 before knitting the 4th row. Knit to Row 43 (45) then SHAPE NECK: Bind off 2 sts. 3x, 1 st. 4x. Knit to Row 97 (103) then cast on 1 st. 4x, 2 sts. 3x. After Row 148 (158) STOP PATTERN. With color 1, knit to Row 152 (162) Remove the sts. onto contrast waste yarn.

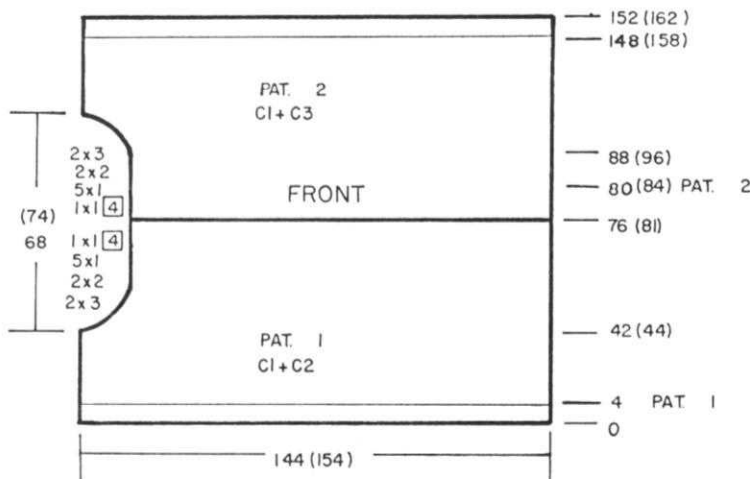

PULLOVER FRONT:

OPEN CAST ON same as you did for the back 144 (154) sts. After The waste knitting, put Counter at 0 and knit 4 rows Stockinette stitch with color 1 Setting Pattern 1 before knitting Row 4 - BUT FOR THE SMALLER SIZE SET PATTERN ON ROW 4 OF THE PUNCH CARD instead of Row 1. Knit in Pattern to Row 43 (45). SHAPE NECK: Follow the Chart for the bind offs. Mark each side for center after row 76 (81) Knit Stockinette stitch with color 1 to Row 80 (84) setting Pattern 2 before knitting Row 80 (84). After Row 89 (97) Follow the Chart for the neck increases. After Row 148 (158), STOP PATTERN and work Stockinette stitch with color 1 to Row 152 (162) then remove the sts. onto contrast waste yarn.



Continued

TURTLE NECK COLLAR - Be sure to hang plenty weights.

1 x 1 Ribbing with change in settings as specified. Tension 3/3

Cast on 144 (154) sts. with color 1. Work the 3 rows circular. Counter 4. PATTERN: (release Part Button on machine).

*Left and right PR Buttons UP.

Knit 4 rows.

Both PR Buttons DOWN.

Knit 2 rows.

REPEAT FROM * for Pattern.

Knit in Pattern to Row 126 (140).

Make sure the last row with PR Buttons DOWN.

Transfer the ribber sts. to main machine. Knit 1 row across the doubled sts. then remove onto contrast waste yarn.

WAISTBAND: Cast on 104 (112) sts.

Work the waistband the same as the sleeves. After the cast on row plus 3 circular rows, knit 2 rows color 2 then with color 1, knit to row 26, knit 2 rows color 2. With color 1, knit to Row 32. Transfer the ribber sts. to main machine. Hang half the waist onto these needles and bind off LOOSELY. Make second waistband the same.

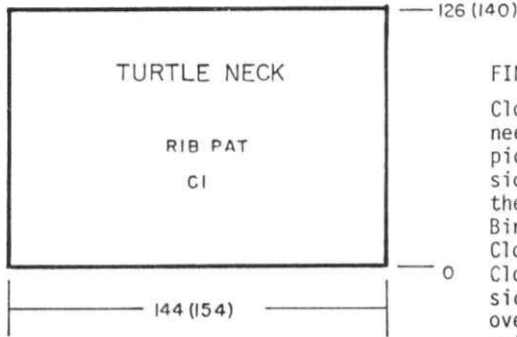

FINISHING:

Close one shoulder. Bring 144 (154) needles into working position then pick up sts. around neck with knit side facing you. Hang the Collar onto these needles with knit side facing you. Bind off LOOSELY.

Close other shoulder plus 1" of collar. Close remainder of collar from other side so seam will not show when turned over. Hang the open sts. of sleeve onto machine with knit side facing you. Hang sts. from garment onto same needles with shoulder at center marked st. Pur1 side facing you. Bind off LOOSELY.

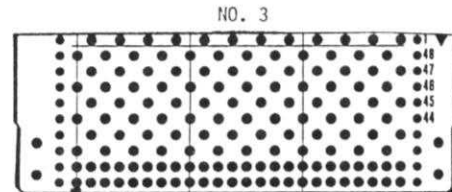
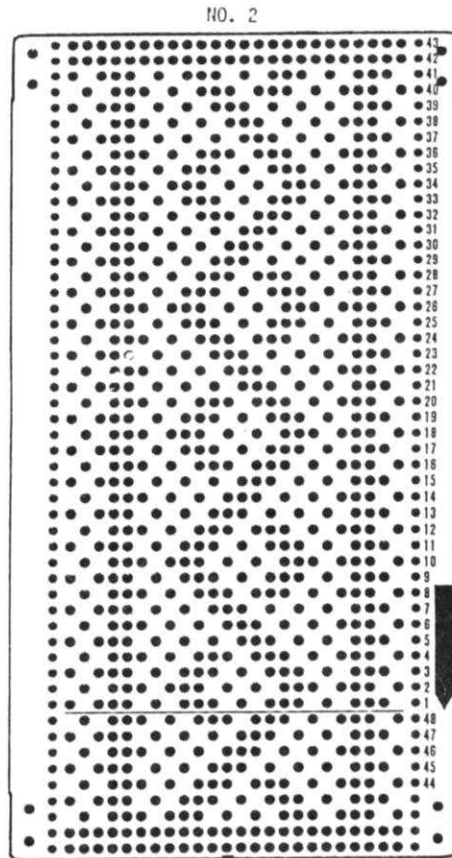
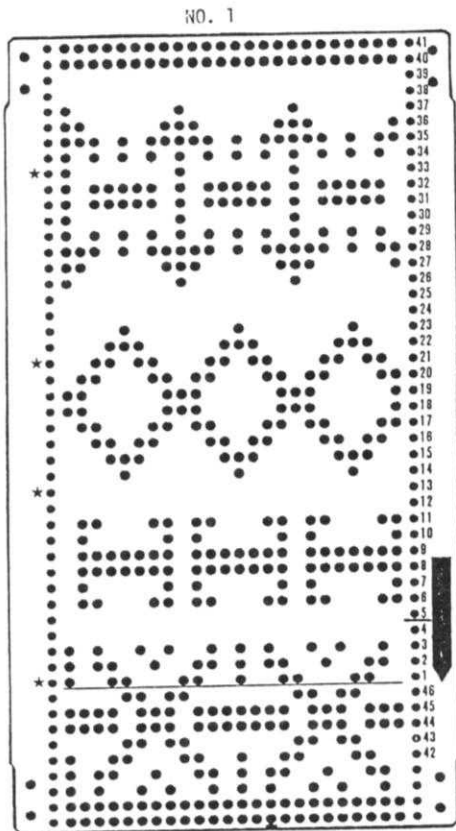
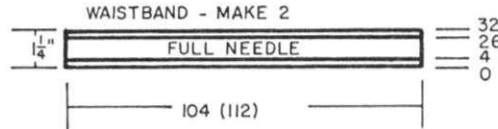

REPEAT THE PUNCH CARD THROUGH ROW 41 then punch 2 rows of holes for connecting Card.



484



LEVEL 1 - Color 1
 Knit 2 rows over all needles.
WORK SHORT ROWS: ALWAYS wrap the inside needle in holding position when Carriage is on the LEFT SIDE. Bring all needles into holding position. Carriage is on the right.
 *Push 1 needle nearest Carriage back into working position. Knit 2 rows. REPEAT FROM * till 9 needles are in work.
 ** Push 2 needles back to working position, knit to the LEFT. ON OPPOSITE SIDE OF CARRIAGE, bring 10 needles into holding position, knit to the right (DO NOT WRAP THIS TIME). ON OPPOSITE SIDE OF CARRIAGE, push 1 needle back to working position knit 2 rows until 9 needles are in work. REPEAT FROM ** until 7 sections are completed. This completes Level 1. Break yarn. REMOVE EACH SET OF 10 sts. from machine onto contrast waste yarn.

to the right. Hang next open stitch onto SAME end needle.
 Knit 2 rows. Continue in this way until all 10 open sts. have been picked up. Remove them onto contrast waste yarn.
 REPEAT FROM * for 5 MORE SECTIONS. Pick up the finished edge of last section onto 10 needles.
 *Knit 2 rows. ON THE RIGHT, decrease 1 st. and REPEAT FROM * till one remains. Bind this st. off.

LEVEL 2 - Color 2
 Carriage on the LEFT.
 Hang LEFT END STITCH from waste yarn onto machine.
 *Knit 2 rows. Pick up next open st. and hang on SAME end needle on the right. Increase 1 st. on the left end. REPEAT FROM * until all sts. from first section has been picked up (10 sts. in working position). Remove these sts. onto contrast waste yarn. CARRIAGE ON THE LEFT.
 *Pick up finished edge of section on the right. 10 sts. in work on the machine. Hang first open stitch from next section onto end needle in work. Bring these needles to E position (this is so that the sts. will knit on next row. Knit 1 row

LEVEL 3 - Color 1
 CARRIAGE ON THE RIGHT.
 Pick up 10 sts. from right finished edge. Pick up 1 open st. from 2nd section and hang onto end needle. Bring the needles to E position (so they will knit) and knit 2 rows.
 *Pick up next open st. and hang onto same needle. Knit 2 rows.
 *Pick up next open st. and hang onto same needle. Knit 2 rows. REPEAT FROM * till all 10 have been picked up. Remove onto contrast waste yarn. Pick up the next 10 sts. from finished edge and work in the same way until 6 MORE sections are completed (7 in all).

WOMENS PULLOVER

SIZES: 12/14 - To make a smaller or larger size, adjust Tension to lower tension for smaller, higher tension for larger.

YARN: Venetia, Fine Mami Rex, Angora

AMOUNT:
 color 1 Venetia - 2 strands with 1 strand Mami Rex. 1 lb. plus 4 spools Mami Rex.
 color 2 Angora - 14 balls

TENSION: 2 strands Venetia with Mami Rex - Tension 3 - Rib. Smallest tension. ANGORA - 1.2

GAUGE: 10 sts. 14.5 rows = 2"

Can be knitted on any BULKY machine with Ribbing Attachment.
 Basket Weave for Yoke and Sleeves.
 1 x 1 Ribbing for Sleeve and Waist Bands.

IMPORTANT: BE SURE TO CHANGE TENSIONS.
 Tension - Color 1 = 2 strands Venetia, 1 strand Mami Rex, Tension 3.

Color 2 - 1 strand of Angora - Tension 1.2.

BACK and FRONT are the same.

Cast on 94 sts. using 2 strands of Venetia and 1 strand of Mami Rex - 94 sts. Work 20 rows K1, P1 Ribbing.

Transfer the ribber sts. to main machine and work Stockinette stitch. ON EACH SIDE increase 1 st. every 13th row 3x.

After Row 90, SHAPE ARMHOLE: ON EACH SIDE, bind off 2 sts. 1x, 1 st. 8x.

After Row 110, remove the sts. onto contrast waste yarn.

YOKE - BE SURE TO PRACTICE knitting a SAMPLE of the BASKET WEAVE FIRST, knitting at least 3 levels so you can see how it works.

Bring 70 needles into working position. Hang the open sts. held on waste yarn onto these 70 needles, decreasing 10 sts. across (double every 7th st.)

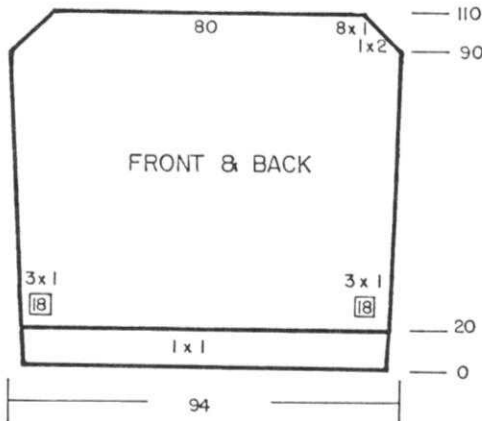
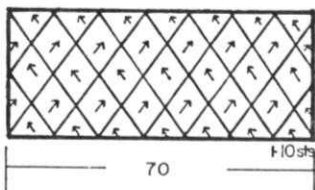

REPEAT LEVEL 2 one time.

LAST LEVEL - Color 1
 CARRIAGE ON THE RIGHT.
 Pick up 10 sts. from right finished edge. Pick up 1 open st. from 2nd section and hang onto end needle. (Bring the needles to E position so they will knit).
 *Knit 1 row. CARRIAGE ON THE LEFT. WORK SHORT ROWS ON THE RIGHT. Put 1 needle opposite Carriage into holding position. Knit 1 row to the right (wrap inside needle in holding to prevent a hole).
 Pick up next open st. and hang onto end needle.
 REPEAT FROM * till 10 needles are in holding position. All needles in work, knit 1 row to the right. Remove the sts. onto contrast waste yarn. Pick up the next 10 sts. then pick up 1 open st. from next section and hang onto end needle. (Bring the needles to E position so they will knit) and CONTINUE FROM *. REPEAT FOR EACH SECTION.



Continued

After Row 208 (214) [220], remove yarn from feeder and move Carriage to the left side.

All needles to the RIGHT of 0 PLUS 32 needles to the LEFT of 0 in holding position. ROW COUNTER 166 (172) [178] With color 1, work the decrease short SAME TIME work the armhole shaping same as before.

as before.
Counter back to Row 166 (172) [178] Needle 31 and 32 to the LEFT of 0 in working position - all others in holding position.

With color 3, work the INCREASE short rows ON EACH SIDE.

Counter 208 (214) [220]. With color 2, knit 6 rows over all needles BUT AT SAME TIME, remember to continue shaping armhole.

Counter 214 (220) [226].

All needles to the right of 0 in work plus 14 needles to the LEFT of 0. All remaining needles on left in holding position.

Work the DECREASE short rows with color 3, 2 sts. 23x.

After Row 262 (268) [274], cut yarn and move Carriage to the left side. Work the INCREASE SHORT ROWS with color stripes as shown on the Chart 2 sts. 23x.

Row Counter 262 (268) [274].

Continue with color 1.

After Row 300 (312) [324], SHAPE SHOULDER AND NECK AT THE SAME TIME FOLLOWING THE CHART.

SLEEVES:

OPEN CAST ON 120 (128) [136].

After the waste knitting, change to color 1 and counter at 0.

Work Stockinette stitch to Row 186 (196) [206].

ON EACH SIDE, work FULL FASHION DECREASING, 2 sts. every 4th row 12x then 2 sts. every 2nd row 2x, 1 st. 1x.

After Row 236 (246) [256], bind off the remaining sts.

SLEEVE BANDS: Make 2.

Cast on 73 (77) [81] sts. with color 1 and work 50 rows K1, P1 Ribbing. Transfer the ribber sts. to main machine then with wrong side facing you, hang the open sts. of sleeve onto these needles, decreasing evenly across. Knit 1 row then bind off.

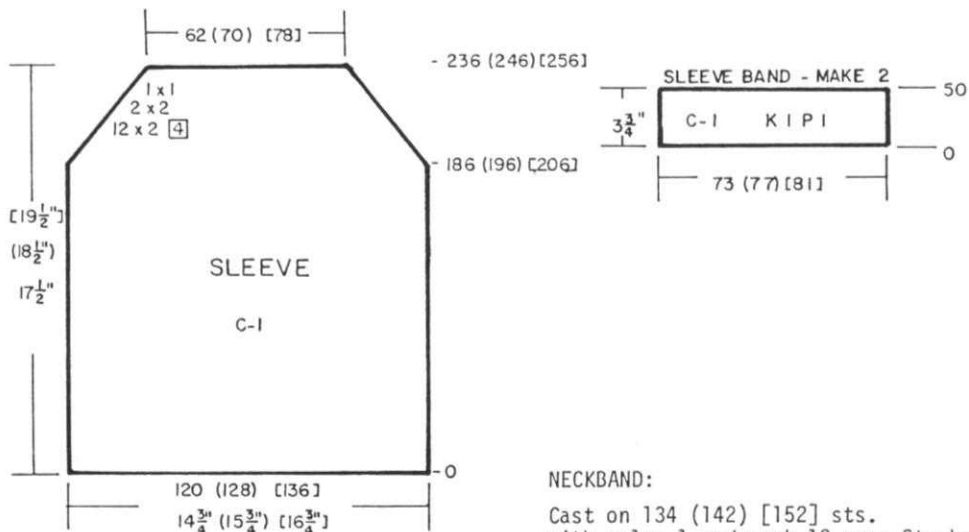

FRONT:

REVERSE THE DIRECTIONS OF EACH COLOR SECTION. Work the front the same as the back to Row 274 (284) [294]. SHAPE NECK AS SHOWN ON THE CHART AND AT THE SAME TIME AFTER ROW 300 (312) [324], SHAPE SHOULDER SAME AS THE BACK.

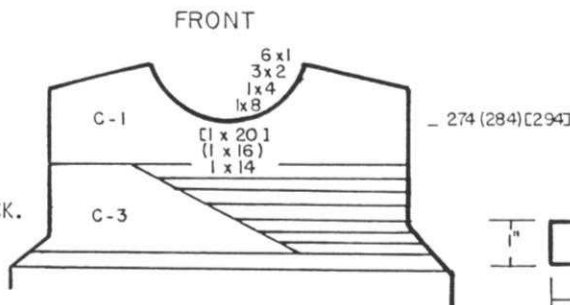

NECKBAND:

Cast on 134 (142) [152] sts. with color 1 and work 12 rows Stockinette stitch. Hang the hem. Sew 1 shoulder then pick up sts. around neckline with wrong side facing you. 62 (64) [68] sts. across the back neck and 72 (78) [84] sts. across the front. Knit 1 row then bind off loosely.

FINISHING: See General Instructions.

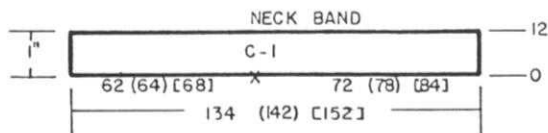

INTARSIA CARRIAGE KA 2600

The new KA 2600 INTARSIA CARRIAGE is made only for the KH 260 Punch Card Bulky knitter. With it, you can knit large pictures, argyle designs or random blocks of different textures in as many colors as you wish without strands of yarn (floats) carried over the purl side of your knitting. When knitting Intarsia designs, the Intarsia Carriage replaces the main carriage of your knitter. It has a tension control dial to match the dial on your machine and it comes complete with a detailed instruction manual in English, Spanish, German, French and Italian.

Order from your local dealer or direct from:
KNITKING, 1128 Crenshaw Blvd., L.A.CA 90019

PRICE: \$34.95
(plus \$2.50 shipping costs)

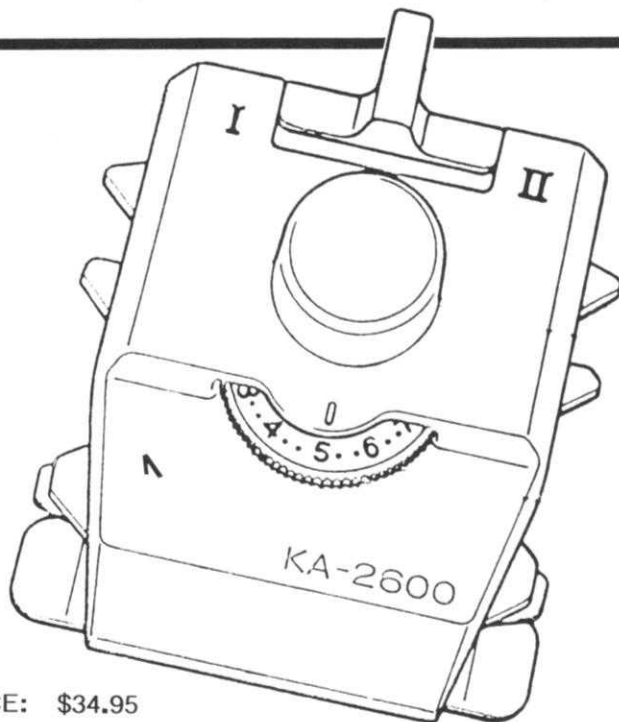



486

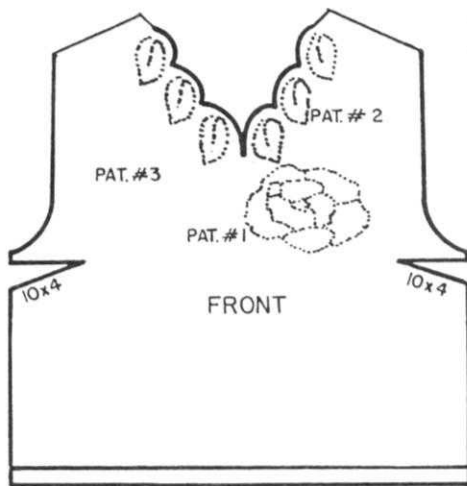

— 276 (288) [300]
 — 270 (282) [294]
 — 208 (216) [224]
 — 166 (174) [182]
 — 156 (164) [172] ROSE
 — 156 (164) [172]

WOMENS 2 PIECE DRESS

SIZES: 6/8 (10/12) [14/16]
 YARN: Venetia
 AMOUNT: 2 lbs. for all sizes.
 TENSION: 4 - RIB 4/3 II
 GAUGE: 16 sts. 26 rows = 2" (5 cm)

Made on the KH 910 machine with Ribber used for bands. Draw your own design.

PULLOVER BACK:

Cast on FULL NEEDLE RIBBING - 150 (164) [178] sts. ON EACH BED. SET RIBBER AS FOLLOWS: Left PR DOWN, Right PR UP Left and right KR Change Knobs turned to the OUTSIDE. Slide Lever on II ON MACHINE, push in LEFT PART BUTTON. Knit 14 rows. Transfer the ribber sts. to main machine (2 sts. on each needle). Release Part Button and continue in Stockinette stitch. After Row 166 (174) [182], SHAPE ARMHOLE: ON EACH SIDE, bind off 5 (6) [7] sts. 1x, 4 (5) [6] sts. 1x, then 4 sts, 1x, 3 sts. 1x, 2 sts. 1x, 1 st. 6x. Knit to Row 264 (276) [288]. Bind off the center 26 (32) [38] sts. put the needles on the left into holding position and complete the right side first. *ON NECK SIDE bind off 6 sts. 2x, 5 sts. 1x, 4 sts. 1x, 1 st. 2x AND AT THE SAME TIME, after Row 270 (282) [294], SHAPE SHOULDER: Bind off 5 sts. 3x (5 sts. 1x, 6 sts. 2x) [5 sts. 1x, 7 sts. 2x]. Bring the needles on the left into working position, knit 1 row to the right side, turn the Row Counter back to 264 (276) [288] and complete the left half. Follow the instructions from *.

PULLOVER FRONT:

Work the front the same as the back to Row 156 (164) [172]. WORK SHORT ROWS FOR THE BUST DART AND DO NOT COUNT THESE ROWS. ON OPPOSITE SIDE OF CARRIAGE, bring into holding position 4 sts. 10x ON EACH SIDE. ON OPPOSITE SIDE OF CARRIAGE, bring the needles back to working position before knitting the next 2 rows. Counter at 156 (164) [172]. After Row 166 (174) [182], SHAPE ARMHOLE same as the back BUT AT THE SAME TIME, Work Pattern 1.

After Row 208 (216) [224], Divide in the center. Remove the sts. on the LEFT side onto waste yarn and complete the right side first. WORK PATTERN 2 AND SHAPE NECK AS SHOWN ON THE CHART. AT THE SAME TIME, after Row 270 (282) [294], SHAPE SHOULDER same as the back. Hang the sts. held on waste yarn back onto the machine. SHAPE NECK and WORK PATTERN 3 as shown on the chart.

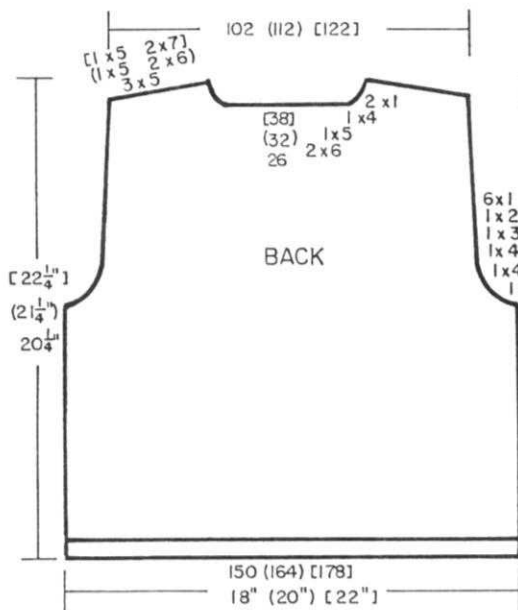

— 276 (288) [300]
 — 270 (282) [294]
 — 264 (276) [288]

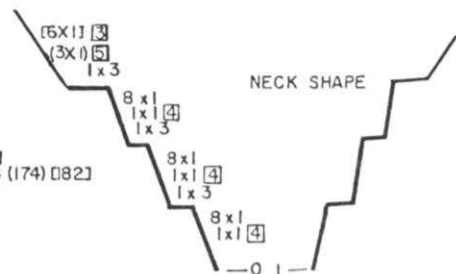

PULLOVER SLEEVES:

OPEN CAST ON with waste yarn 60 (68) [76] sts. After knitting 9 to 11 rows, knit 1 row with Ravel Cord to the right side. Change to garment yarn and put Counter at 0. Knit 4 rows Stockinette stitch then work Pattern 4. AT THE SAME TIME, ON EACH SIDE, increase 1 st. every 10th row 11x (12x) [13x], then every 4th row 1 st. 15x. After Row 178 (184) [190] SHAPE CAP: ON EACH SIDE, bind off 5 sts. 1x, 4 sts. 1x, 3 sts. 1x, 1 st. 4x then every 4th row 1 st. 15x. then every 2nd row, 1 st. 11x (13x) [14x]. After Row 274 (284) [294], bind off the remaining sts.

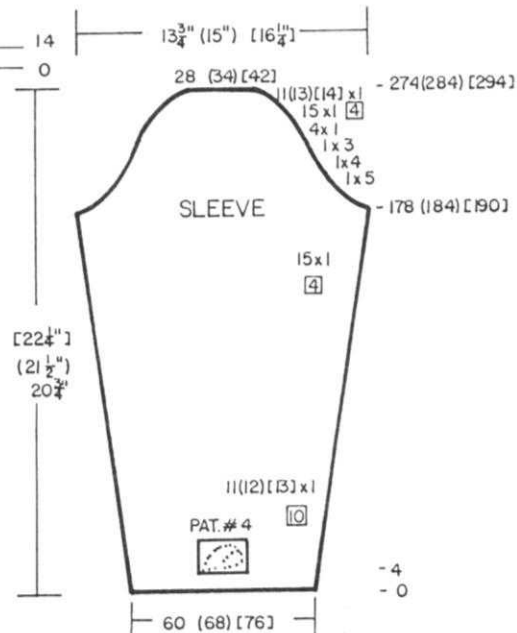

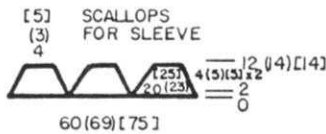
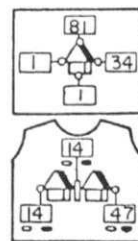
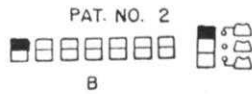
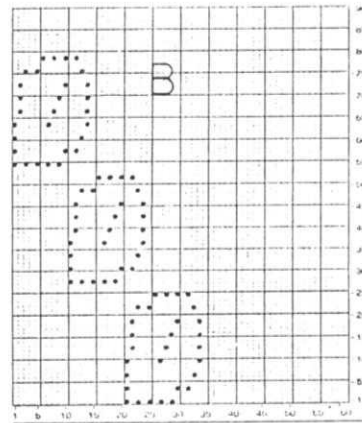
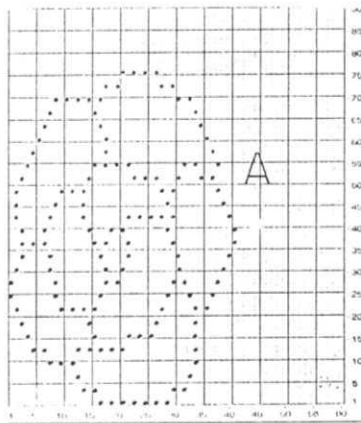
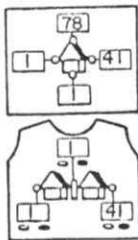

SCALLOPS FOR SLEEVES:

Bring 60 (69) [75] needles into working position then hang the open sts. from sleeve onto these needles. For the 2nd size pick up an extra stitch - for the 3rd size, decrease 1 stitch (when picking up the waste knitting).

Knit 2 rows. Knit 1 scallop at a time.

You will use 20 (23) [25] sts. for each of 3 scallops.

Leave 20 (23) [25] sts. in work and put the remaining sts. into holding position.

*WORK SHORT ROWS. ON OPPOSITE SIDE OF CARRIAGE, put into holding position 2 sts. 4 (5) [5] times ON EACH SIDE.

Bring the needles opposite carriage into working position before knitting the next 2 rows. Bind off.

Bring the next 20 (23) [25] sts. into working position and follow the instructions from *. REPEAT for 3rd scallop.

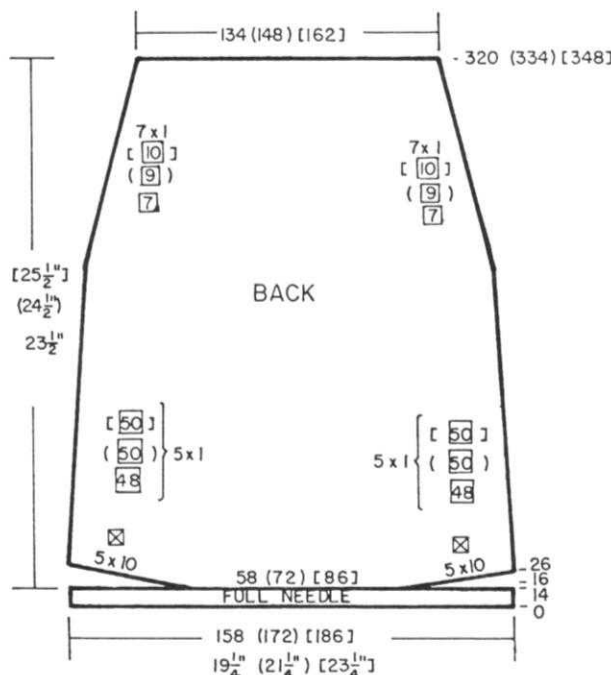
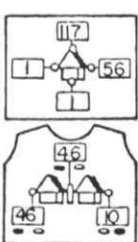
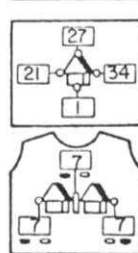
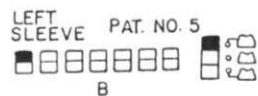
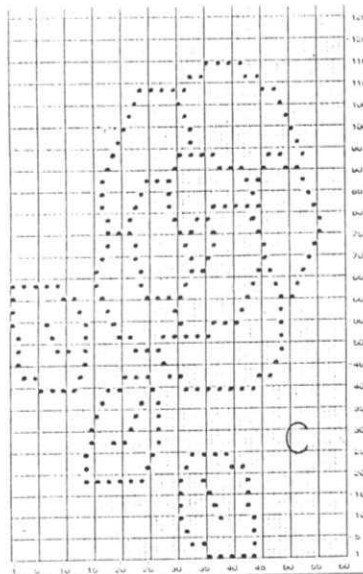
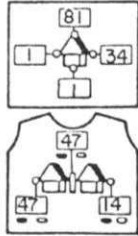
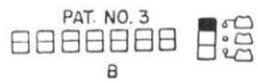

SKIRT BACK:

Cast on FULL NEEDLE RIBBING - 158 (172) [186] sts. ON EACH BED and work the Ribbing same as you did for Pullover.

After Row 14, transfer the ribber sts. to main machine in the same manner.

Knit 2 rows Stockinette then work SHORT ROWS: ON OPPOSITE SIDE OF CARRIAGE, bring into holding position 50 sts. before knitting the next 2 rows.

ON OPPOSITE SIDE OF CARRIAGE, push back to working position 10 sts. 5x ON EACH SIDE. (BE SURE TO WRAP the inside needle in holding position to prevent a hole while knitting Short Rows). Continue in Stockinette stitch AND ON EACH SIDE, decrease 1 st. immediately then decrease 1 st. every 48th (50th) [50] row 47 x (49x) [49x] MORE.

ON EACH SIDE, decrease 1 st. every 7th (9th) [10] row 7x. After Row 320 (334) [348], remove the remaining sts. onto contrast waste yarn.



Continued

SKIRT LEFT FRONT

Cast on FULL NEEDLE RIBBING 134 (142) [150] sts. and work 14 rows ribbing same as for skirt back.

Transfer the ribber sts. to main machine and continue in Stockinette stitch.

Knit 2 rows, then work SHORT ROWS.

ON THE LEFT, bring 50 sts. into holding position, knit across then on the RIGHT, bring 56 sts. into holding position.

ON EVERY 2nd row, ON THE LEFT, push back into working position 10 sts. 5x and ON THE RIGHT, push back 8 sts. 1x, 4 sts. 2x, 2 sts. 20x.

When all the needles are back into working position, ON THE RIGHT SIDE, cast on 6 sts.

ON THE LEFT SIDE, work the DECREASES same as you did for the back and ON THE RIGHT SIDE, decrease 1 st. every 50th row 5x.

After Row 320 (334) [348], remove the sts. onto contrast waste yarn.

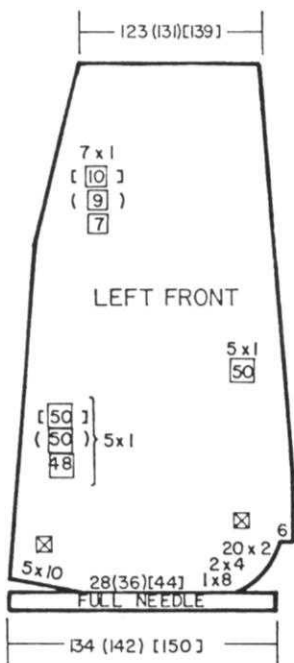

FRONT BAND TRIM: Make 2. KNIT THIS BEFORE KNITTING THE WAISTBANDS:

Bring 131 (138) [145] needles into working position. With wrong side facing you, pick up the LOOPS along front edge and hang onto these needles.

Bring the ribber needles to E position and the knitter needles to E position.

Set machine for the SPECIAL RIBBING.

Knit 14 rows full needle ribbing. Transfer the ribber sts. to main machine. Bring all needles to E position so that they will knit when you knit 1 row across.

Bind off. Fold the bands to the inside and hem in place.

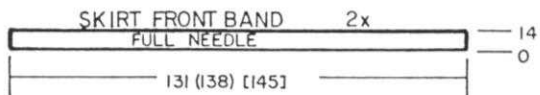

BELT:

FULL NEEDLE SPECIAL RIBBING as you have done before.

Cast on 6 sts. on BOTH BEDS.

Knit to Row 1200. Transfer the ribber sts. to main machine and bind off.

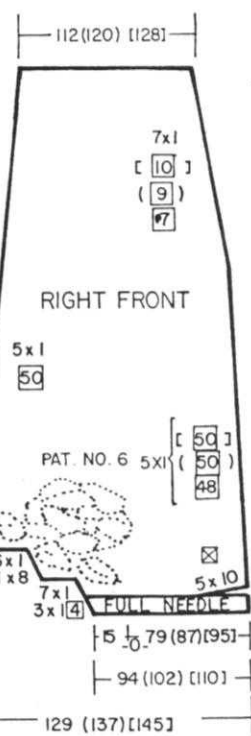
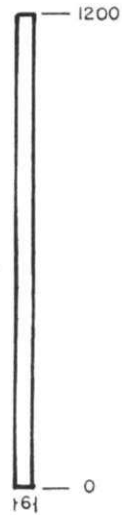

SKIRT RIGHT FRONT:

Cast on FULL NEEDLE RIBBING same as before having 15 sts. to the LEFT OF 0 and 79 (87) [95] sts. to the RIGHT OF 0.

Work the 14 rows of ribbing BUT AT THE SAME TIME, ON THE LEFT SIDE, INCREASE 1 st. every 4th row 3x and after row 14, transfer the ribber sts. and continue in Stockinette stitch.

WORK THE SHORT ROWS same way as you did for the other sections (SEE CHART) and ON THE LEFT SIDE, on every 2nd row, increase 1 st. 7x, then cast on 8 sts. 1x, increase 1 st. 6x, cast on 8 sts. 1x, increase 1 st. 3x. BUT AT THE SAME TIME, work Lace Pattern 6.

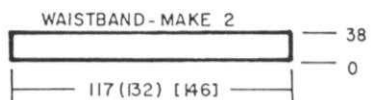

SKIRT WAISTBAND: Make 2.

Cast on 117 (132) [146] sts. and work 38 rows Stockinette stitch. Hang the hem.

Pick up the sts. from skirt back that are held on waste yarn with the wrong side facing you, decreasing evenly across. Knit 1 row over all sts. then bind off loosely.

Knit the front waistband the same. Hang the RIGHT SKIRT FRONT beginning at the right edge of band (wrong side facing you) then hang the LEFT Skirt section beginning at the left edge of band OVERLAPPING the center front trim (See Picture).

FINISHING: See General Instructions. Work 4 rows single crochet across pattern edge of skirt to form scallops and around neckline and sleeve edges.

MACHINE KNITTING FASHION

The leading knitting publication from England. It contains 36 complete and outstanding patterns for women, men and children. Illustrated in full color this edition (8½"x11") has a special group of patterns using the Garter Carriage.

Garments are knitted with Punch Card, Electronic and Bulky machines. At \$6.95 postpaid anywhere in the world, its definitely a 'Best Buy'.

Order direct from KNITKING
1128 Crenshaw Blvd., Los Angeles CA 90019



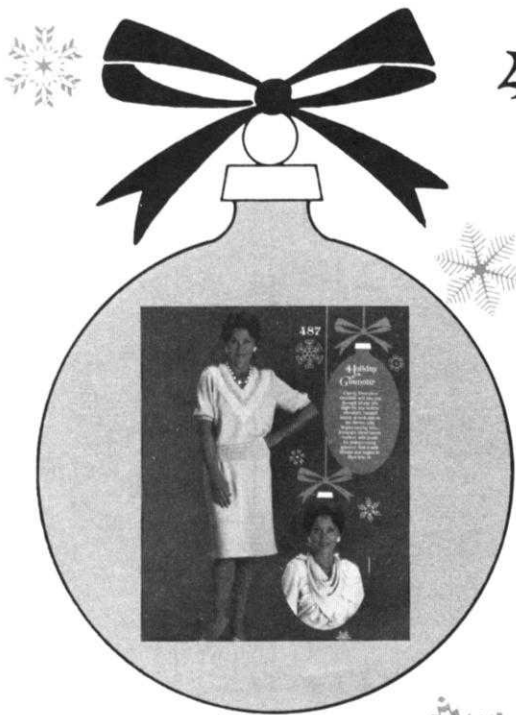

487

TOP FRONT:

Work the front the same as the back to Row 138 (148). Divide in the center. Put the needles on the left into holding position and complete the right side first.
 *ON NECK SIDE, decrease 1 st. every 3rd row 43x (45x) BUT AT THE SAME TIME, make BUST DART after Row 165 (175). DO NOT COUNT the Bust Dart rows. ON OPPOSITE SIDE OF CARRIAGE bring into holding position, 5 sts. 8x. All needles in work, knit to the right. Turn Counter to 166 (176). SHAPE ARMHOLE same as the back.

After Row 274 (288), bind off the remaining 7 (11) sts. Bring the needles on the left into working position, knit 1 row to the left side, turn the Row Counter back to 138 (148) and complete the left half. Follow the instructions from *

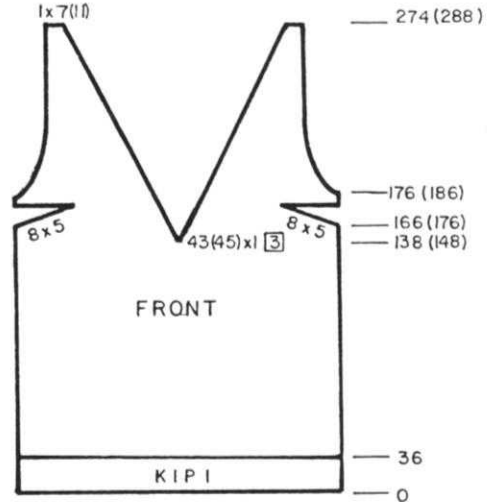

WOMENS 3-PIECE DRESS

SIZES: 8/10 (12/14)
YARN: Veneti- and Angora
AMOUNT:
 color 1 Venetia - 2 lbs.)both
 color 2 Angora - 2 balls)sizes
TENSION: T 4.1 Top T 4 Skirt
 T 4 Shawl
GAUGE: Top - 16 sts. 25 rows = 2"
 Skirt - 17 sts. 26 rows = 2"
 Ribber - Tension 2/2 II

Made on any Electronic or Punch Card machine. KII 910 machine owners use Pattern No. 8-29 from original set of Patterns supplied with your machine.

The Angora Trim is knitted with Tension 10 OVER EVERY OTHER NEEDLE.

TOP BACK:

Cast on 147 (163) sts. with color 1 and work 36 rows K1, P1 Ribbing. Transfer the ribber sts. to main machine and increase 1 st. on the right side.

Continue in Stockinette stitch After Row 176 (136), SHAPE ARMHOLE: ON EACH SIDE, bind off

5 (6) sts. 1x, 4 (5) sts. 1x, 4 sts. 1x, 3 sts. 1x, 2 sts. 1x, 1 st. 6x.

Knit to Row 268 (284).

Bind off the center 12 (18) sts., put the needles on the left into holding position and complete the right side first.

*ON NECK SIDE, bind off

5 sts. 1x, 4 sts. 1x, 3 sts. 1x, 2 sts. 1x (1 st. 1x) AND AT THE SAME TIME, after Row 274 (288)

SHAPE SHOULDER: Bind off

10 sts. 3x (8 sts. 4x).

Bring the needles on the left into working position, knit 1 row to the left side, turn the Row Counter back to 268 (284) and complete the left half. Follow the instructions from *.

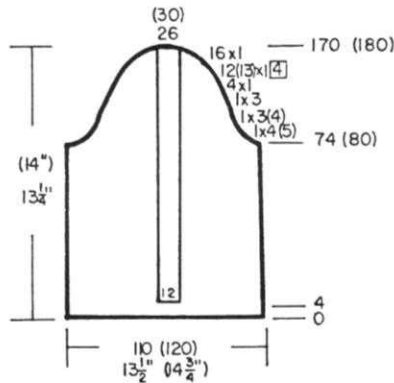

FOR SLEEVES

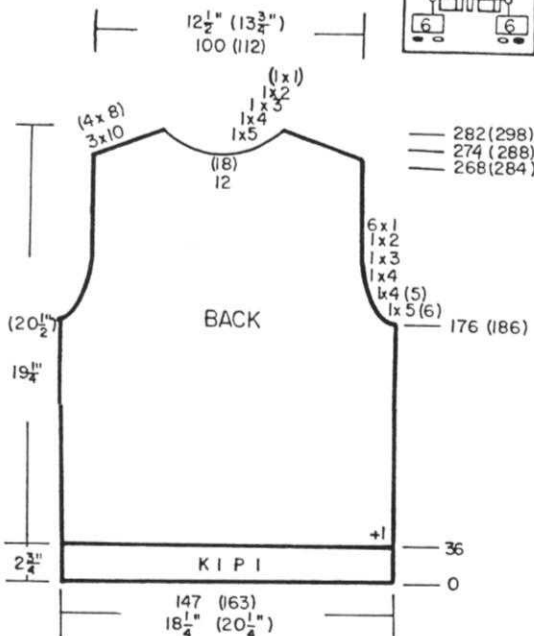
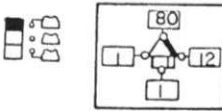

SLEEVES: - Color 1

With contrast waste yarn, cast on 110 (120) sts. After knitting 9 to 11 rows, knit 1 row with Ravel cord to the right side. Turn Counter to 0. Knit 4 rows Stockinette stitch setting the Lace Pattern before knitting the 4th row. ISOLATE THE PATTERN OVER THE CENTER 12 sts. Knit to Row 74 (80).

SHAPE CAP: ON EACH SIDE, bind off 4 (5) sts. 1x, 3 (4) sts. 1x, 3 sts. 1x, 1 st. 4x. 1 st. every 4th row 12x (13x), 1 st. every 2nd row 16x. After Row 170 (180), bind off the remaining sts.

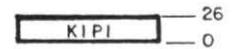

SLEEVE CUFF: | 83 (93) |

Cast on 83 (93) sts. with color 1 and work 26 rows K1, P1 Ribbing. Transfer the ribber sts. to main machine. With wrong side facing you, hang the OPEN STS. from sleeve onto these needles, doubling the sts. as needed across. Remove waste yarn. Knit 1 row then bind off loosely.

LACE INSERT: Make 1, reverse 1.

Begin and end with contrast waste yarn.

Cast on 64 (70) sts.

Work STOCKINETTE STITCH and ON THE LEFT, cast on 2 sts. 7x.

After Row 16, CONTINUE IN LACE PATTERN and ON THE LEFT, INCREASE 1 st. 9x. After Row 34, remove onto waste yarn.

LACE INSERT - MAKE 1, REVERSE 1

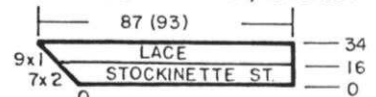

FOR NECK INSERT

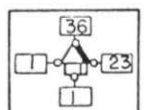

Continued

ANGORA - NECK TRIM - Make 2

BEGIN AND END with contrast waste yarn.

Cast on 10 sts. OVER EVERY OTHER NEEDLE. TENSION 10.

Knit to Row 64 (68). Remove onto contrast waste yarn.

Make 2nd piece the same BUT AFTER ROW 64 (68) leave the section on the machine and directly next to it, hang the first section with purl side facing you onto every other needle. You now have 20 sts. Work Stockinette stitch and after Row 2, ON EACH SIDE, decrease 1 st. every 2nd row 9x. Bind off the remaining 2 sts.

Pin, then sew this piece onto Top BELOW the Lace after you have attached Lace side of INSERT to neckline.

ANGORA - NECKLINE TRIM

BEGIN AND END with contrast waste yarn.

Cast on 6 sts. OVER EVERY OTHER NEEDLE. Tension 10.

Work Stockinette stitch to Row 46 (60). Remove onto waste yarn. Make a second piece the same but knit to Row 98 (106) and leave on the machine. Hang the first section back onto machine with purl side facing you same as you did for Neck Trim.

Knit 2 rows then ON EACH SIDE, decrease 1 st. every 2nd row 6x. Pin, then sew this to NECKLINE with point at center front. Weave the open sts. at shoulder and remove the waste yarn. (See Picture).



ANGORA NECK TRIM

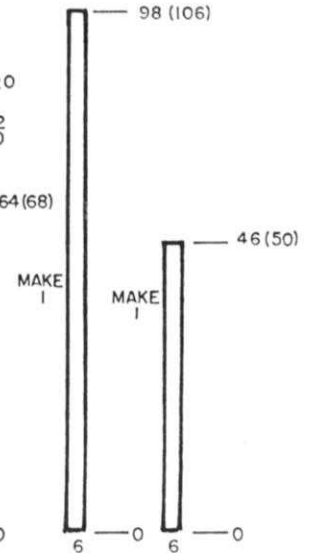
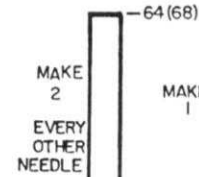
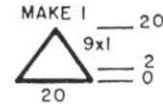
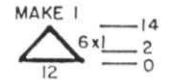

SKIRT: T 4 - Make 2.

FULL NEEDLE RIBBING: See Special Instructions on Practical Knitting Hints page in this issue.

With color 1, cast on 174 (190) sts. and work 18 rows Ribbing. Transfer the ribber sts. to main machine and continue in Stockinette stitch.

WORK SHORT ROWS: ON OPPOSITE SIDE OF CARRIAGE, bring 50 sts. into holding position (be sure to wrap inside needle in holding position to prevent a hole) before knitting the next 2 rows.

ON OPPOSITE SIDE OF CARRIAGE, bring back into working position 5 sts. 10x ON EACH SIDE.

Knit to Row 314 (330). Mark center 2 sts. ON EACH SIDE OF 0 and mark sts. 31, 42, 64. ON EACH SIDE (these are numbers on the needle bed but you must mark the sts.) Use a bit of contrast waste yarn for marking.

This is the FRONT. Knit the back the same except you need to mark only the center 2 sts. before you remove the sts. onto contrast waste yarn.

WAISTBAND: Make 2.

Cast on with cast-on comb or waste yarn, 116 (132) sts. and work Stockinette stitch.

Knit to Row 38, then hang the hem. Hang the center of FRONT marked sts. onto the center 2 needles.

Hang the FIRST MARKED ST. ON EACH SIDE (inside st.) onto needle 24 ON EACH SIDE. Double up the sts. as needed across the center. Hang the NEXT 11 sts. ON EACH SIDE onto the next 11 needles, and MAKE PLEAT over these needles - You will have 3 sts. on each of these 11 needles. Hang the remaining sts. on each side.

Bring all the needles into holding position so that they will be sure to knit as you knit 1 row, then bind off.

Make the BACK WAISTBAND the same except you do not have pleats. Hang the back skirt at center, then double up the center 58 sts. with 29 (37) single sts. at each side.

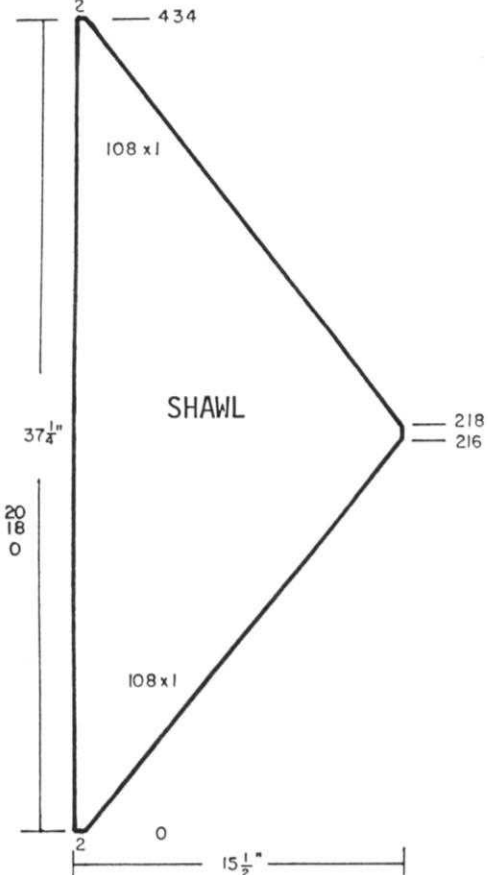
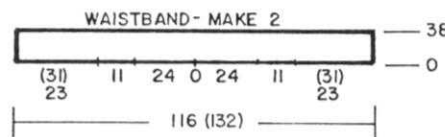
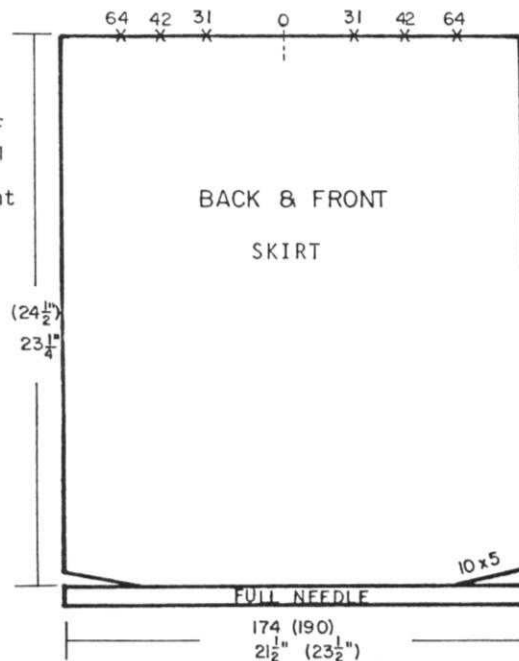

SHAWL: T 5

With color 1, cast on 2 sts. ON THE LEFT SIDE OF MACHINE. ON EVERY 2nd row increase 1 st. ON THE RIGHT SIDE 108x.

After Row 218, ON THE RIGHT SIDE, DECREASE 1 st. every 2nd row 108x. After Row 434, bind off the remaining 2 sts.

Use Feathers and Beads on the shaped edges sewing them approximately 2" apart (See picture) or you can use Tassels.

FINISHING: See General Instructions. Attach Lace insert then sew Angora Trim in place.





WOMENS TWO-PIECE DRESS

SIZES: 8/10 (12/14)
YARN: Venetia, Mami Rex (fine) and Angora

AMOUNT:
 color 1 Venetia - 2 lbs. } all
 color 2 Mami-Rex - 6 spools } sizes
 color 3 Angora - 16 balls }
TENSION: TOP - T 3 Rib - T 1/1 II
 SKIRT - T 5
 SLEEVES: T 6.2
GAUGE: TOP - 10 sts. 14.5 rows = 2"
 SKIRT - 15 sts. 25 rows = 2"
 SLEEVES - 8 sts. 10 rows = 2"

The Top is stockinette stitch with single Motif in Thread Lace. It is knitted on the KH 260 Bulky machine. Knit the Skirt on any Standard Punch Card machine. Punch 2 Cards. Knit the Collar for Top on the Standard machine in 1 x 1 Ribbing.



TOP BACK: KH 260 Bulky - Use 2 strands of Venetia, 1 strand Mami Rex.

Cast on 83 (93) sts. and work 20 Rows K1, P1 Ribbing. Transfer the ribber sts. to main machine. Continue in Stockinette stitch. Increase 1 st. on the right. ON EACH SIDE, increase 1 st. every 18th row 4x.

After Row 92 (96) SHAPE ARMHOLE: ON EACH SIDE, bind off 3 (4) sts. 1x, 2 (3) sts. 1x, 2 sts. 2x, 1 st. 4x. Knit to Row 144 (152)

Bind off (or remove onto waste yarn the center 12 (14) sts., then remove all the sts. on the LEFT onto waste yarn. Complete the right side first.

*SHAPE SHOULDER AND NECK AT THE SAME TIME.

FOR SHOULDER, bind off 4 sts. 3x, 3 sts. 2x (4 sts. 5x)

FOR NECK, bind off 4 sts. 1x, 2 sts. 2x, 1 st. 1x. Hang the sts. held on waste yarn back onto machine and knit 1 row to the left side. Turn the Row Counter back to 144 (152) and complete the left half. Follow the instructions from *.

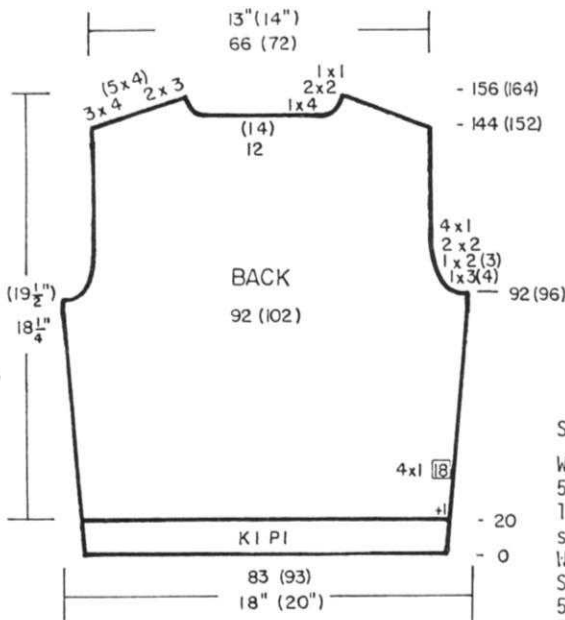
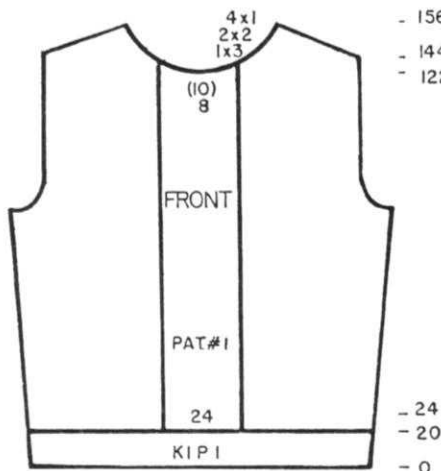

TOP FRONT: (Pattern 1)

Work the same as the back to Row 20. Knit 3 rows Stockinette stitch then attach LEFT AND RIGHT MOTIF CAMS and place them in the center of machine. Insert Punch Card. SET PATTERN on next row - knitting left to right. Set Carriage for Thread Lace and continue in Pattern. After Row 92 (96) SHAPE ARMHOLE same as the back.

After Row 122 (126), bind off the center 3 (10) sts. (or remove on waste) Remove the remaining sts. on the left onto waste yarn. (mark card row number).

*ON NECK SIDE bind off 3 sts. 1x, 2 sts. 2x, 1 st. 4x and after Row 144 (152) SHAPE SHOULDER same as the back. Hang the sts. held on waste yarn back onto machine. Knit 1 row in Pattern to the left side, turn the Row Counter back to 122 (126) and complete the left half. Follow the instructions from *.

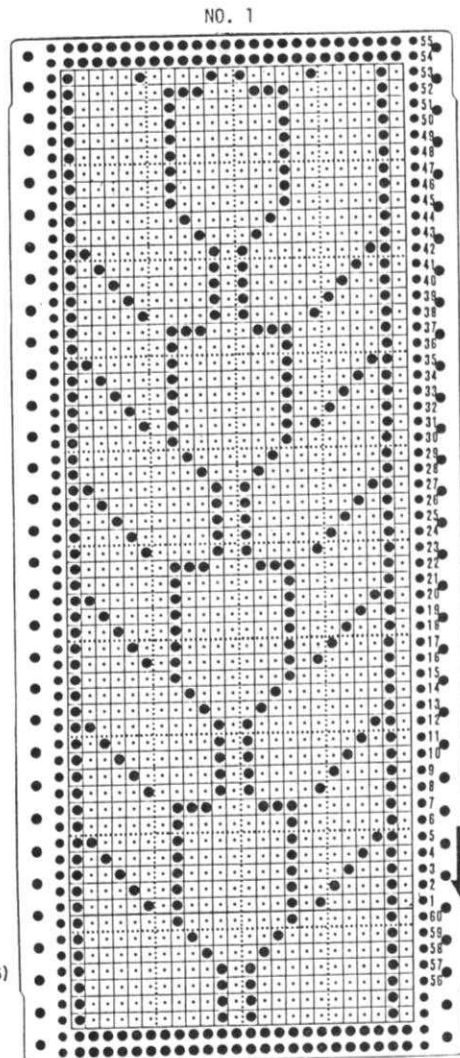

SLEEVES: - Bulky Machine T 6.2

With contrast waste yarn, cast on 54 (60) sts. Knit 9 to 11 rows, 1 row with Ravel cord to the right side. Change to ANGORA, counter at 0. Work Stockinette stitch and ON EACH SIDE, increase 1 st. every 2nd row 5x.

After Row 20 (22) SHAPE CAP: ON EACH SIDE bind off 3 (4) sts. 1x, 2 sts. 2x, 1 st. 4x, 1 st. every 4th row 7x (8x). After Row 62 (68) bind off the remaining sts.

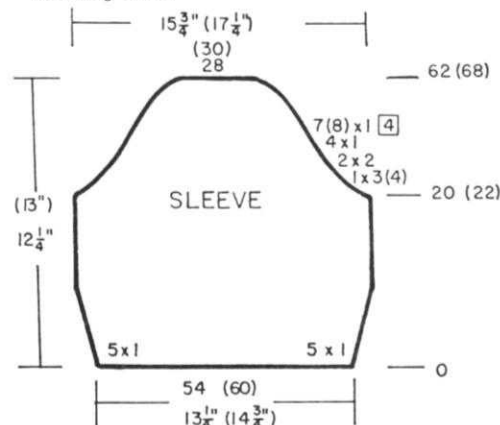

Continued

SLEEVE BAND: T 6.2(same as sleeve)

Cast on with contrast waste yarn same as for sleeves - 54 (60) sts. Put Counter at 0 and with Angora, knit 8 rows. Remove onto contrast waste yarn.

THREAD LACE BAND FOR SLEEVE.

Cast on with contrast waste yarn same as for sleeves. 11 stitches. 6 sts. to the left of 0 and 5 sts. to the right of 0. PUNCH CARD 2.

After the waste knitting, use 2 strands Venetia and 1 strand Mami Rex. ISOLATE the design same as for Front. Knit 1 row then set Pattern left to right and work in Thread Lace to Row 64 (80). Remove onto waste yarn.

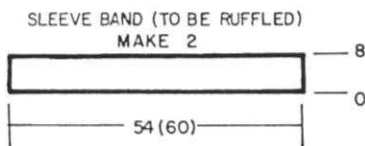

BAND OF THREAD LACE FOR CUFF - MAKE 2

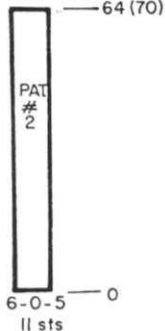

ANGORA COLLAR - Standard Machine.

BACK: Cast on 84 (96) sts. and work K1, P1 Ribbing. With Ten. 6/6 work the cast on and circular rows.

Ten 10/8 knit 12 rows
Ten 9/7 knit 12 rows
Ten 8/6 knit 12 rows
Ten 7/5 knit 12 rows
Ten 6/4 knit 12 rows.

After Row 60, transfer the ribber sts. to main machine and remove onto contrast waste yarn. FRONT: Cast on 113 (123) sts. and work the same as for back collar.

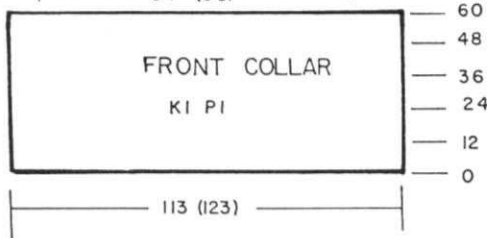
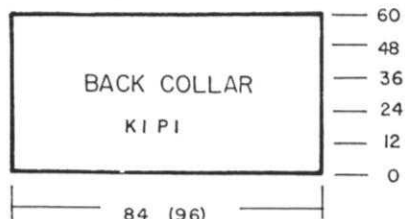

UNDER BAND FOR COLLAR

2 strands Venetia, 1 strand Mami Rex. TENSION 1

BACK: Bring 28 (32) needles to working position (B). With wrong side facing you, pick up the open sts. from back neck and hang onto these needles. Remove waste yarn. With Tension 1, knit 8 rows Stockinette stitch then remove onto contrast yarn.

FRONT: - Bring 50 (54) needles to working position (B) and work same as for back section.

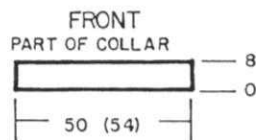
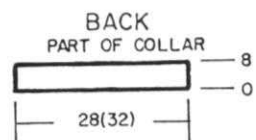

FINISHING: See General Instructions.

SLEEVE: Attach the Lace Band to the Angora sleeve by gathering 2 1/2" all across and attach the sleeve band to the lace band by gathering it the same way. Crochet the underband of collar to the collar - Use No. 2 crochet hook and for the back, pick up 3 sts. from collar, 1 from under band and slip stitch LOOSELY. Attach front collar in the same way but pick up 2 sts. from Collar 3x then 3 sts. 1x and REPEAT ACROSS. With 2 strands of Venetia and 1 strand of Mami Rex work single crochet around sleeve ruffle and collar.

SKIRT: Standard Machine - T 5

OPEN CAST ON SAME AS BEFORE ending with 1 row with ravel cord to the right side.

Use 1 strand of Venetia and 1 strand of Mami Rex. DO NOT USE ROW COUNTER. Knit 2 rows.

*Bring all but 36 sts. on the RIGHT into holding position and knit 2 rows. ALWAYS WRAP INSIDE NEEDLE IN HOLDING POSITION TO PREVENT A HOLE.

PUSH BACK 25 sts. to work and knit 2 rows.

PUSH BACK 5 sts. to work and knit 2 rows.

Bring 20 sts. to holding position and knit 2 rows.

ALL NEEDLES IN WORK, knit 4 rows. REPEAT FROM * 2x MORE.

This completes 1 section A. Leave 36 needles in work on the right side, all others in HOLDING. Knit 2 rows.

PUSH BACK 25 sts. to work and knit 2 rows.

PUSH BACK 85 sts. to work and knit 2 rows.

PUSH BACK 30 sts., knit 2 rows. Bring into holding position

15 sts. knit 2 rows.

Bring 95 sts. to holding, knit 2 rows.

Bring 20 sts. to holding, knit 2 rows.

ALL NEEDLES IN WORK, knit 4 rows.

REPEAT FROM THE BEGINNING (See Chart) until there are 25 (27) complete sections A and B ending with 2 rows over all needles.

Remove onto contrast waste yarn.

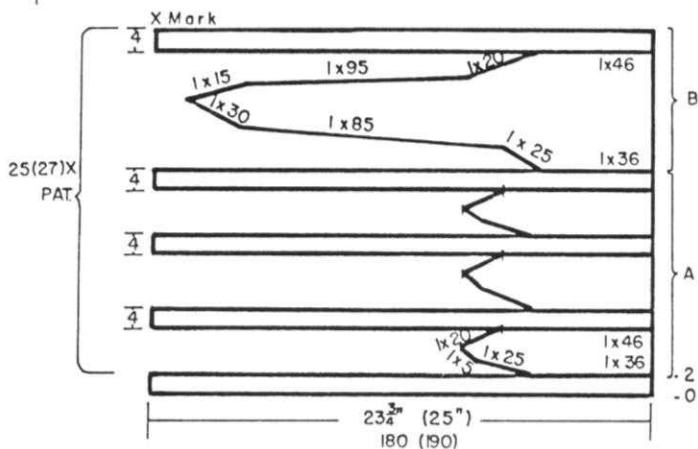

SKIRT WAISTBAND - Make 2

Bring 120 (130) needles into working position then with wrong side facing you hang HALF the skirt waist onto these needles. Knit 38 rows Stockinette st. Hang the first row of Waistband onto the machine and bind off LOOSELY. REPEAT FOR 2nd half.

WAISTBAND - MAKE 2

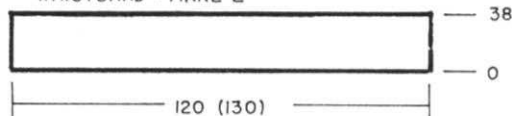

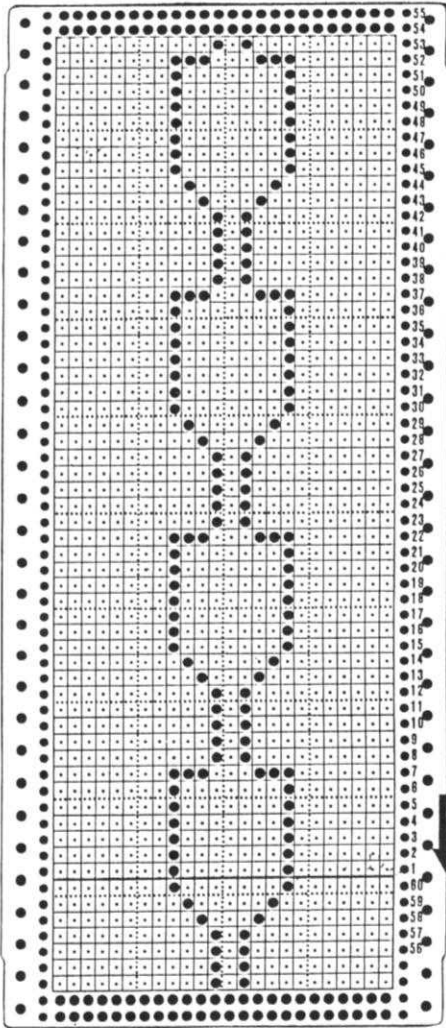

489



WOMENS PULLOVER

SIZES: 6/8 (10/12) [14/16]
 YARN: Amore
 AMOUNT:
 color 1 4 4 5 balls
 color 2 3 3 3 balls
 color 3 1 1 1 ball
 TENSION: 6 Rib. 4/3.1 II
 GAUGE: 14 sts. 24 rows = 2" (5 cm)

Stockinette stitch with an Intarsia Design on the front section. Bands are K1,P1 Ribbing. You will need approx. 30" of yellow yarn for the Moon. Send \$1.00 plus large No. 9 self addressed and stamped envelope for full size copy of design.

FRONT:

Work the front the same as the back to Row 106 (112) [118] then begin the INTARSIA DESIGN, changing the colors as shown on the Chart.

AT THE SAME TIME, after Row 176 (182) [188], SHAPE ARMHOLE same as the back.

After Row 242 (252) [262] Bind off the center 14 (16) [20] sts. put the needles on the left into holding position and complete the right side first.

*ON NECK SIDE, bind off 4 sts. 1x, 2 sts. 3x, 1 st. 3x, 1 st. every 4th row 3x.

After Row 276 (288) [300], bind off the remaining sts.

Bring the needles on the left into working position, knit 1 row to the left side, turn the Row Counter back to 242 (252) [262] and complete the left half. Follow the instructions from *.

BACK:

With color 1, cast on 129 (139) [151] sts. and work 46 rows K1, P1 Ribbing. Transfer the ribber sts. to main machine and increase 1 st. on the right side.

With color 1, knit to Row 132 (138) [144]. Change to color 2.

After Row 176 (182) [188], SHAPE ARMHOLE: ON EACH SIDE, bind off 4 sts. 1x, then decrease 2 sts.

FULL FASHION 6x (7x) [8x].

Knit to Row 250 (260) [270].

SHAPE SHOULDER: ON EACH SIDE, bind off

2 sts. 13x (14x) [15x]. After Row 276 (288) [300], remove the sts. onto contrast waste yarn.

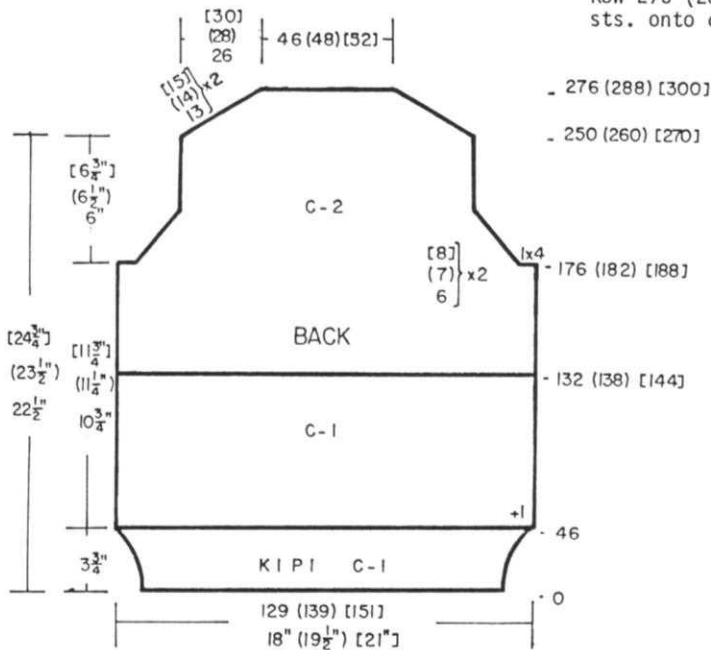

- 276 (288) [300]
 - 250 (260) [270]

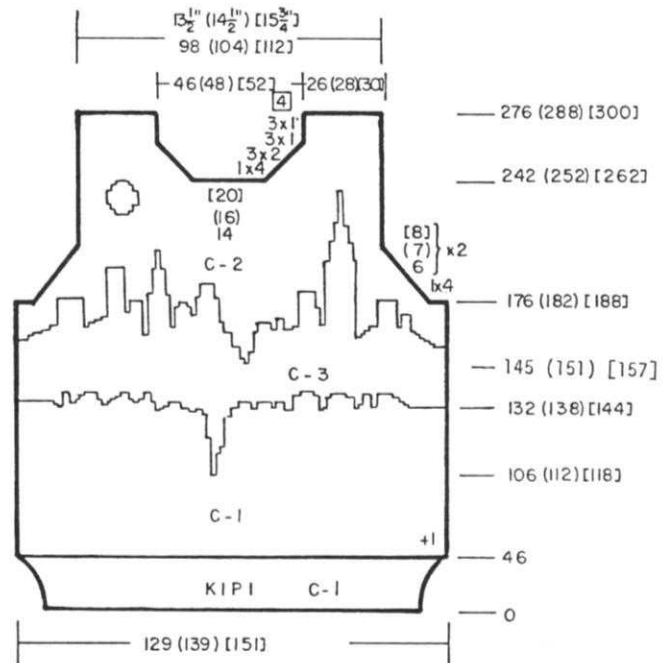

— 276 (288) [300]
 — 242 (252) [262]
 — 176 (182) [188]
 — 145 (151) [157]
 — 132 (138) [144]
 — 106 (112) [118]
 — 46
 — 0



Continued

SLEEVES:

Cast on 65 (69) [73] sts. with color 1 and work 46 rows K1, P1 Ribbing. Transfer the ribber sts. to main machine and increase 1st. on the right.
Continue in Stockinette stitch. ON EACH SIDE, increase 1 st. every 8th row 16x (17x) [18x]. After Row 184 (188) [192], continue in Color 2.
After Row 196 (202) [208], SHAPE CAP: ON EACH SIDE, bind off 4 sts. then on every 4th row, decrease 2 sts. (full fashion) 8x (9x) [10x then 2 sts. every 5th row 6x, 2 sts. every 2nd row 4x, 1 st. 1x, After Row 272 (282) [292], bind off the remaining sts.

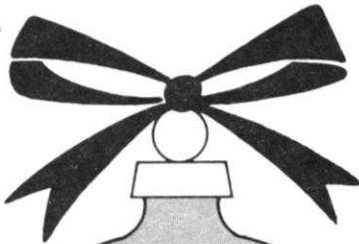
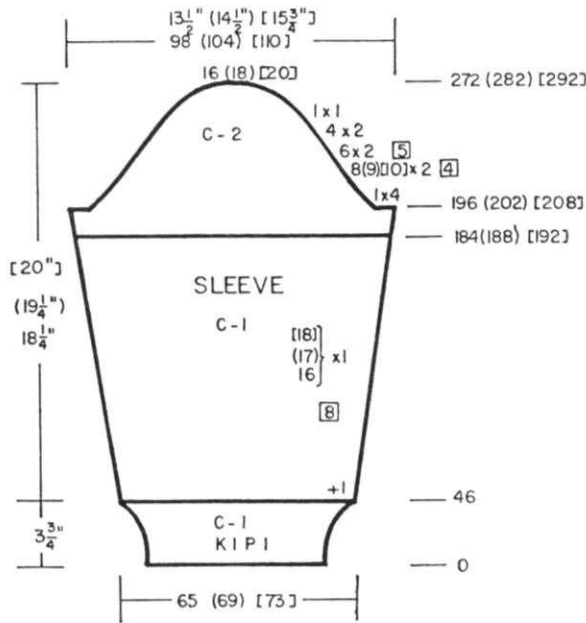

490



WOMENS 2-PIECE DRESS

SIZES: 8/10 (12/14) [16]
YARN: Venetia
AMOUNT:
color 1 1 1/2 2 2 lbs.
color 2 5 5 5 oz.
TENSION: 4 to 5 Rib. 0/0 II
GAUGE: 16 sts. 26 rows = 2"

Knitted on any Standard machine with Lace Carriage.
Bands are K1, P1 Ribbing.
Punch Card or draw on Mylar Sheet.
Skirt is Stockinette stitch with Full Needle ribbing for band at lower edge. Top-Knitted sideways.

SKIRT: Make 2 sections.

FULL NEEDLE RIBBING: Cast on 168 (186) [196] sts. T 4/3 II with color 1 and work 12 rows Full needle Ribbing. Transfer the ribber sts. to main machine. Knit 1 loose row then change to garment tension. Knit 1 row to the right then **WORK SHORT ROWS:**
ON OPPOSITE SIDE OF CARRIAGE, bring into holding position 41 sts. before knitting the next 2 rows. Always wrap the inside needle in holding position to prevent a hole.
ON OPPOSITE SIDE OF CARRIAGE, bring back into working position 26 sts. 2x, 15 sts. 1x ON EACH SIDE.
Continue in Stockinette stitch and ON EACH SIDE, decrease 1 st. every 50th row 4x.
After Row 262 (270) [278], ON EACH SIDE, decrease 1 st. every 8th (9th) [10th] row 7x.
After Row 310 (324) [338], remove the sts. onto contrast waste yarn.

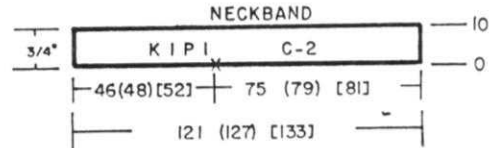

NECKBAND: Close 1 shoulder first.

With color 2, cast on 121 (127) [133] sts. and work 10 rows K1, P1 Ribbing. Transfer the ribber sts. to main machine. Pick up sts. (wrong side) around neck for shoulder to shoulder with 46 (48) [52] across back neck and the remaining 75 (79) [81] distributed evenly for front. Knit 1 row then bind off LOOSELY.

FINISHING: See General Instructions.

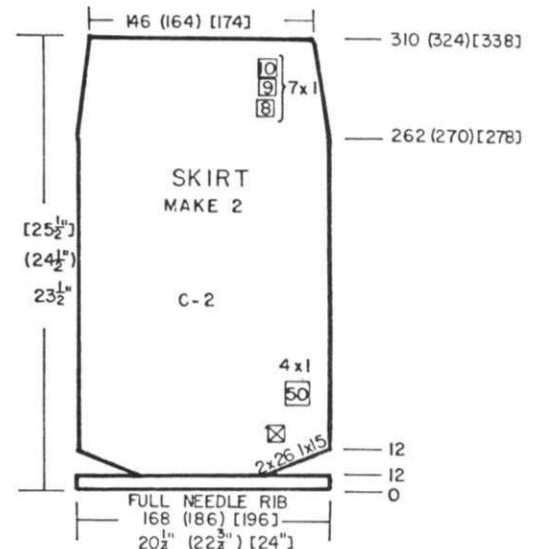

SKIRT WAISTBAND: Make 2.

OPEN CAST ON with contrast waste yarn (117 (132) [146] sts.
 Knit 9 to 11 rows then 1 row with Ravel Cord to the right side.
 Change to color 1 and work 38 rows Stockinette stitch.
 Pick up the first row of band to form a hem then with wrong side of skirt facing you, hang the open sts. of waist onto these needles, decreasing evenly across.
 Knit 1 LOOSE ROW, then bind off LOOSELY.

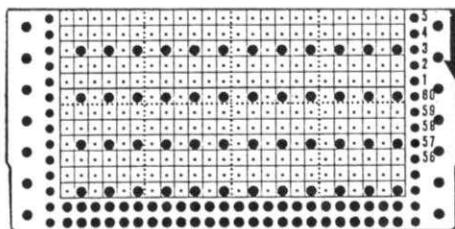

REPEAT the Punch Card through Row 53, then punch 2 rows of holes for connecting Card.

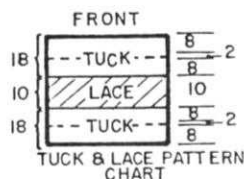
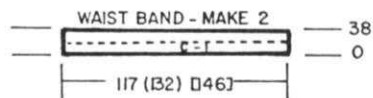

INSTRUCTIONS FOR LACE STRIPES:

With color 1, knit to the Eyelet Row.
 *Make the eyelets across then change to color 2.
 Work to the LAST eyelet row as shown on the Chart.
 Make the eyelets across then change to color 1.
 Knit with color 1 to next eyelet Row.
 REPEAT FROM * for Lace stripes.

FRONT: The front has eyelet stripes with a TUCK ROW.
 Knit to Tuck Row as shown on the Chart. Select for Tuck from right to left and make tuck row from left to right. Release controls for Tuck Pattern.
 Knit to next eyelet Row as shown on the Chart and continue to follow the Chart for Pattern changes.

TOP BACK:

TO THE RIGHT OF 0, OPEN CAST ON 44 (48) [52] sts. with waste yarn. Knit 9 to 11 rows then 1 row with Ravel Cord to the right side.
 Counter at 0. Change to color 1. Work Stockinette stitch to Row 28 (30) [32]. Follow the SPECIAL INSTRUCTIONS for Lace Stripes. AT THE SAME TIME, ON THE RIGHT, increase 1 st. every 10th row 25x (27x) [29x] AND AT THE SAME TIME ON THE LEFT, increase 1 st. every 10th row 18x (19x) [20x].
 After Row 185 (197) [209] at underarm, cast on 2 sts. every 2nd row 3x.
 After Row 193 (205) [217], at UNDER-ARM, cast on 55 (56) [61] sts. Continue to follow the Chart to Row 278 (292) [306].
 SHAPE NECK: Bind off 1 st. 5x.
 After Row 323 (341) [359], mark each edge with bit of contrast yarn for CENTER of garment.
 Continue in Lace Pattern as before.
 After Row 360 (384) [404], increase 1 st. every 2nd row 5x.
 Continue Pattern and AT THE SAME TIME, ON SHOULDER SIDE after Row 396 (412) [432], begin the decreases in place of increases as shown for your size on the Chart.
 After Row 455 (479) [503], bind off 55 (56) [61] sts. then bind off on every 2nd row 2 sts. 3x.
 Continue in Pattern and DECREASE at underarm as shown on the Chart.
 After Row 646 (682) [718], remove the sts. onto contrast waste yarn.

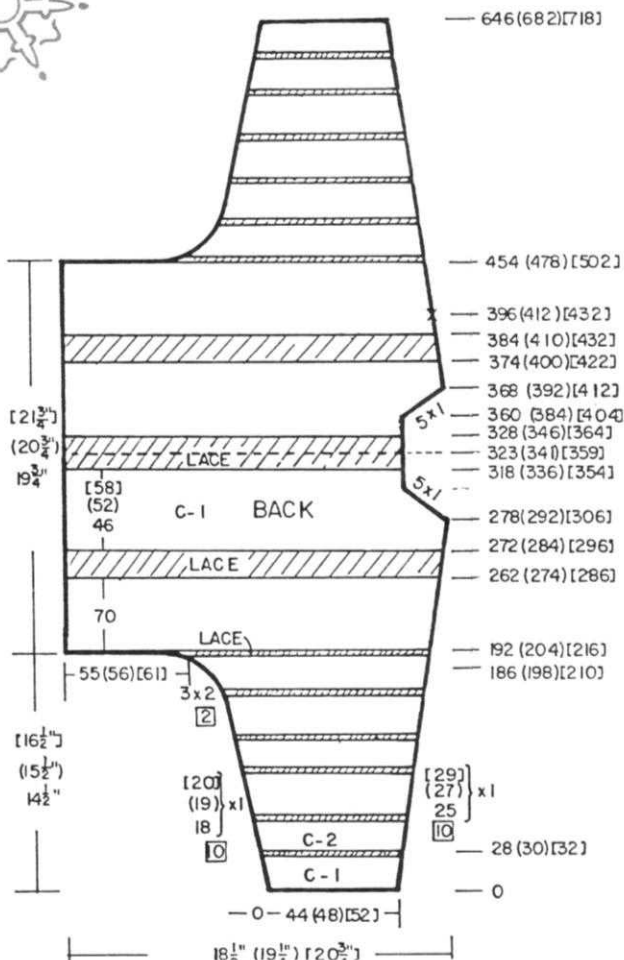

Continued

FRONT:

Work the front the same as the back to Row 262 (274) [286]. Follow the SPECIAL INSTRUCTIONS for TUCK STITCH with LACE. After Row 308 (320) [332], continue in Stockinette stitch to Row 314 (328) [342]. SHAPE NECK: Bind off 2 sts. 10x (11x) [12x]. After Row 354 (372) [390] begin TUCK and LACE Pattern same as before. After Row 377 (395) [413], mark each edge with bit of contrast yarn for center of garment. Continue in Pattern to Row 400 (418) [436] then continue in Stockinette stitch. After Row 422 (442) [462], increase for neck instead of decreasing 2 sts. 10x (11x) [12x]. After Row 446 (470) [494], work the special TUCK and LACE Pattern same as before then continue in Stockinette stitch BUT AT THE SAME TIME, after Row 504 (520) [540], ON SHOULDER SIDE, decrease 1 st. every 10th row 25x (27x) [29x]. After Row 563 (587) [611], bind off 55 (56) [61] sts. then at UNDERARM, decrease instead of increase as shown on the Chart. Continue in Pattern to Row 754 (790) [826]. Remove the sts. onto contrast waste yarn.

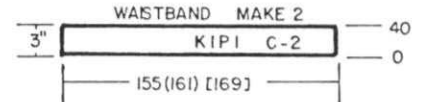
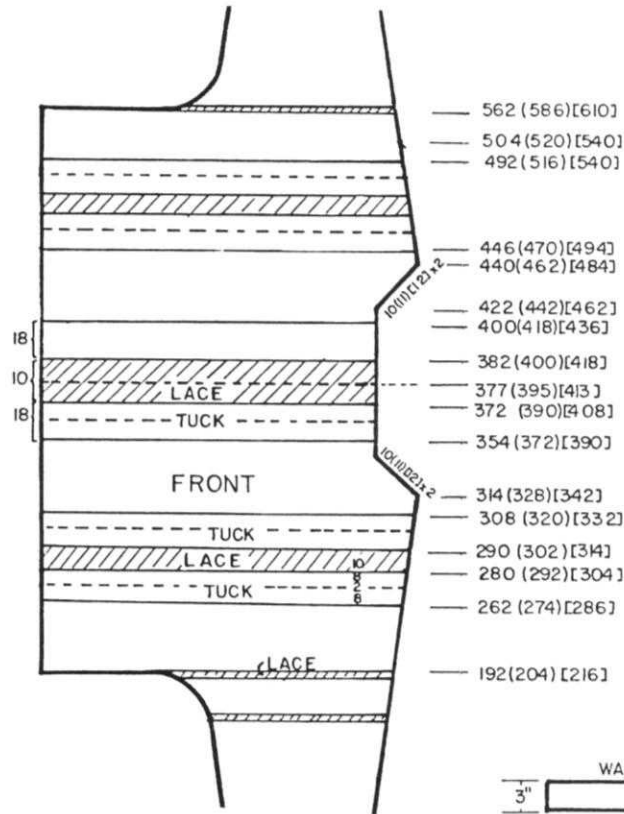

NECKBAND: Make before Sleeve bands:

Close 1 shoulder first, matching the lace patterns and at SHOULDER OF FRONT SECTION, INVERT THE PLEAT on the RIGHT SIDE using the Tuck Row as a guide. With color 2, cast on 114 (120) [126] sts. and work FULL NEEDLE RIBBING T 4/3 II. Knit 10 rows. Transfer the ribber sts. to main machine. Bring all the needles to holding position and with color 1 knit 2 rows over all needles. Make Eyelet Design same as for sleeve. After Row 16, with color 1 knit to row 22. With wrong side facing you, pick up the sts. around neckline from shoulder to shoulder BUT AT THE SAME TIME FORM PLEAT ON THE FRONT SECTION by inverting the pleat on the right side, using the tuck row as a guide. The PLEAT must be directly in CENTER FRONT then distribute the remaining sts. with approximately 46 (48) [50] sts. for the back neck and the remaining divided on each side of front pleat. Bind off loosely.

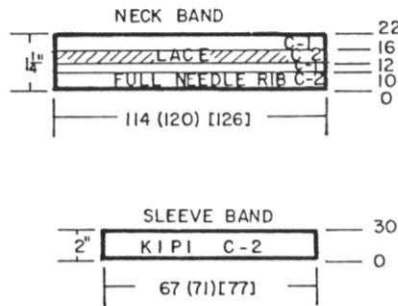

WAISTBAND: Make 2.

Cast on 155 (161) [169] sts. with color 2 and work 40 rows K1, P1 Ribbing. Transfer the ribber sts. to main machine. With wrong side facing you, pick up the sts. across and on the front section be sure to form the pleats same as you did before. Bind off loosely.

SLEEVE BANDS:

Close other shoulder same as you did before. Cast on 67 (71) [77] sts. with color 2 and work 30 rows K1, P1 Ribbing. Transfer the Ribber sts. to main machine. With wrong side facing you, pick up open sts. from sleeve edge and hang onto same needles with approximately 1 st. on first 2 needles then 2 on next needle and repeat across. Knit 1 row then bind off loosely.

FOR SLEEVE

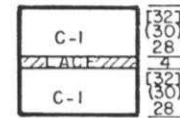

STRIPE PATTERN CHART

FINISHING: See General Instructions. On the front section, measure down 5 1/2" from neck and shoulder edge then tack pleat in place. (See Picture).



491



UNIVERSAL PULLOVER

SIZES: Small (Medium) [Large]

YARN: Amore

AMOUNT:

color 1 7 8 9 balls
color 2 2 2 2 balls

TENSION: 5 to 6 Ribbing for Waistband and Sleeve bands 5/4 II - Ribbing tensions for collar and neckband - see Chart.

GUAGE: 15 sts. 24 rows = 2" (5 cm)

Can be made on any Electronic machine. Pattern for Skiers in Electronic Pattern Book - Variation Pattern # 2 on page 50. Isolated Patterns. Sleeve and Waistbands, K1, P1 Ribbing. Collar or Neckband - see Chart.

FRONT:

With color 1, cast on 137 (147) [157] sts. and work 30 rows K1, P1 Ribbing. Transfer the ribber sts. to main machine and increase 1 st. on the right side.

Continue in Stockinette stitch to Row 34 (40) [46]. Work Pattern No. 1. After Row 108 (192) [202] Work Pattern No. 2. After Row 182 (192) [202], work Pattern No. 3 and at the same time SHAPE ARMHOLE after Row 186 (192) [198]. ON EACH SIDE, bind off 6 sts. 1x, 2 sts. 2x, 1 st. 8x (9x) [10x]. After Row 256 (266) [276], remove the center 10 (12) [16] sts. onto contrast waste yarn, put the needles on the left into holding position and complete the right side first.

*ON NECK SIDE, bind off 3 sts. 2x, 2 sts. 2x, 1 st. 3x (9x) [10x] and After Row 284 (296) [308], SHAPE SHOULDER same as the back.

Bring the needles on the left into working position, knit 1 row to left side, turn the Row Counter back to 256 (266) [276] and complete the left half. Follow the instructions from *.

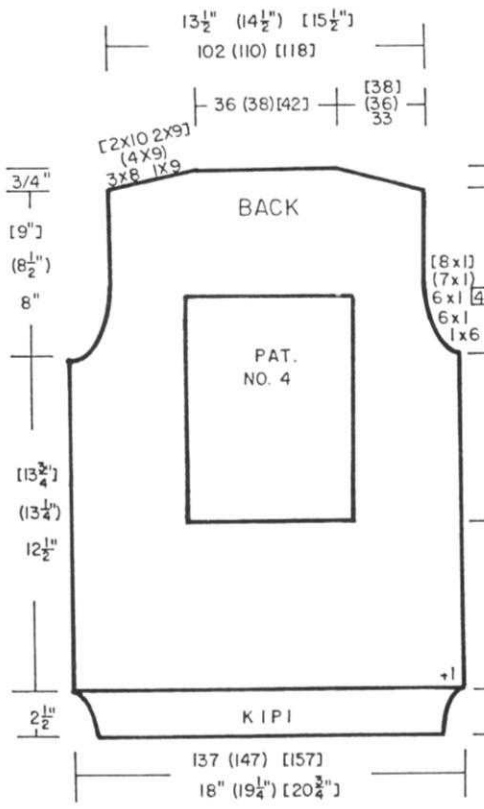

BACK:
With color 1, cast on 137 (147) [157] sts. and work 30 rows K1, P1 Ribbing. Transfer the ribber sts. to main machine and increase 1 st. on the right side. Continue in Stockinette stitch to Row 130 (140) [150]. Work PATTERN NO. 4 and after Row 186 (192) [198], SHAPE ARMHOLE: ON EACH SIDE, bind off 6 sts. 1x, 1 st. 6x, 1 st. every 4th row 6x (7x) [8x]. After Row 284 (296) [308], SHAPE SHOULDER: ON EACH SIDE, bind off 8 sts. 3x, 9 sts. 1x (9 sts. 4x) [10 sts. 2x, 9 sts. 2x].

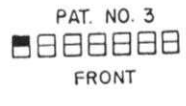
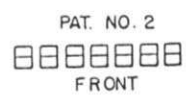
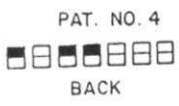
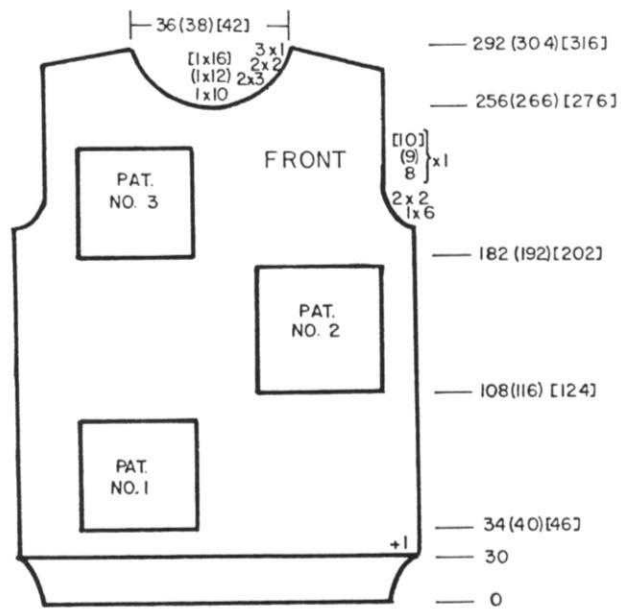
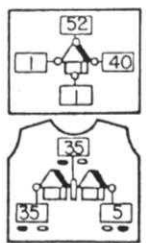
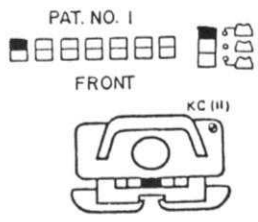

After Row 292 (304) [316], remove the remaining sts. onto contrast waste yarn.



continued

RIGHT SLEEVE: Reverse the Pattern No. 5 for left sleeve.

Cast on 67 (71) [75] sts. with color 1 and work 30 rows K1, P1 Ribbing. Transfer the ribber sts. to main machine and increase 1 st. on the right side. Continue in Stockinette stitch. ON EACH SIDE, increase 1 st. every 10th row 14x (15x) [16x] and AT THE SAME TIME, after Row 154 (162) [170], work Pattern No. 5. After Row 190 (198) [206], SHAPE CAP: ON EACH SIDE, bind off 6 sts. 1x, 3 sts. 1x, 1 st. 6x, 1 st. every 3rd row 16x (18x) [20x] then decrease 1 st. EVERY ROW 10x. After Row 266 (280) [294], bind off the remaining sts. REVERSE PATTERN (See Program Chart).

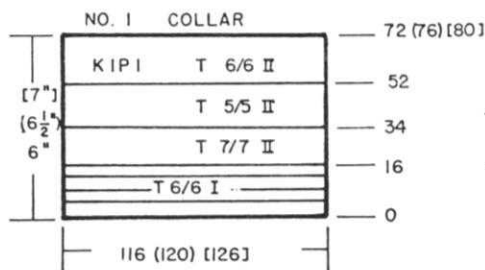

COLLAR:

Cast on 116 (120) [126] sts. with color 1 and work K1, P1 Ribbing changing the tensions as shown on the Chart. After the cast on rows, *Knit 4 rows with Racking Lever on 5, Change Racking Lever to 7 and knit 4 rows and repeat from * 1 time more.

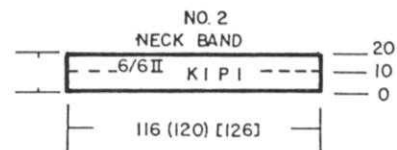
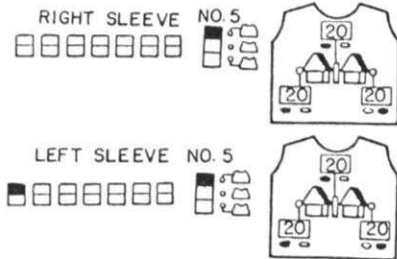
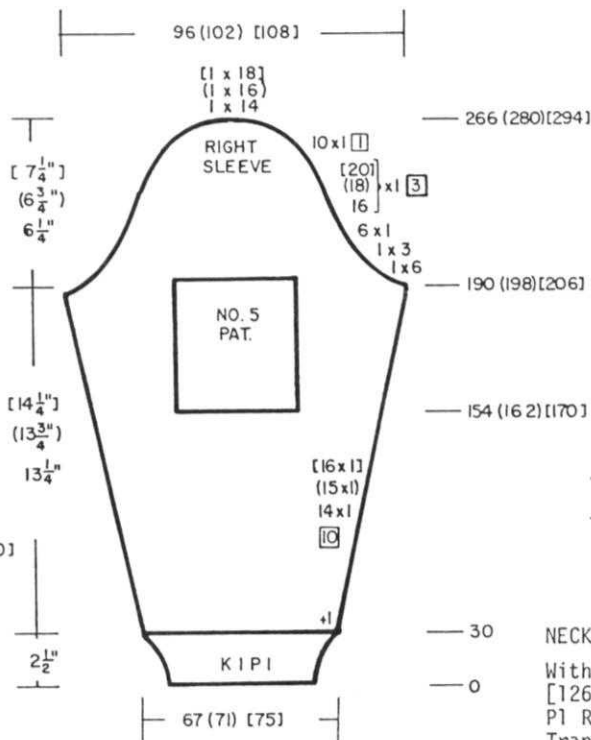

NECKBAND (Use as alternate to Collar).

With color 1, cast on 116 (120) [126] sts. and work 20 rows K1, P1 Ribbing with Tension 6/6 II. Transfer the ribber sts. to main machine. Close 1 shoulder first, the with wrong side facing you, pick up the sts. from neckline and hang onto these needles. Knit 1 loose row then bind off. Fold band to the inside and sew in place.

FINISHING: See General Instructions.

Racking Lever back to 5 then continue in ribbing to Row 72 (76) [80]. Transfer the ribber sts. to main machine. Close one shoulder then pick up the stitches around neck and hang onto these needles. Knit 1 LOOSE ROW then bind off. BE SURE WRONG SIDE OF GARMENT FACES YOU WHEN PICKING UP NECK STS.

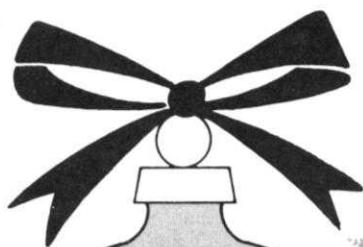

492

WOMENS PULLOVER & SKIRT

SIZES: 6/8 (10/12) [14/16]
 YARN: Venetia, Mami Rex & Angora
 AMOUNT:
 color 1 Venetia 1 3/4 lb. for all sizes.
 color 2 Venetia 4 oz.) used
 Mami Rex - 1 spool) together
 color 3 Angora 3 balls (1 box)
 TENSION: 4 Rib. 0/0 II
 FULL NEEDLE RIB 4/3 II
 GAUGE: Stock. 16 sts. 26 rows = 2"
 TENSION for Angora on BULKY machine
 4 - GAUGE: 9 sts. 14 rows = 2".

Pullover body is knitted on the Electronic machine, the sleeves on any Bulky machine.
 FOR SKIRT use Skirt Pattern from 486 - only reverse the left Front section to use for the RIGHT FRONT. Waist and sleeve bands are K1, P1 Ribbing.



IMPORTANT: Please make sample first.

DECREASE SHORT ROWS: -
 Set Cam for holding needles, SET MACHINE for Multi-color knitting. ON OPPOSITE SIDE OF CARRIAGE, bring the required number of needles to holding position and the following 2 needles must ALWAYS be placed in 'D' (selecting) position so they will ALWAYS knit with the contrast color.
 The decrease short rows when working the Fair Isle Design are exactly the same BUT YOU MUST SET and work the Pattern AT THE SAME TIME.

Please make sample first.
 INCREASE SHORT ROWS:

ON OPPOSITE SIDE OF CARRIAGE, push back 2 needles to 'D' (selecting position) *Knit 1 row. ON SAME SIDE AS CARRIAGE, bring the SAME 2 needles to 'D' position and OPPOSITE CARRIAGE bring 2 needles to 'D' position. REPEAT FROM *. When working the increase Short Rows with Fair Isle Design, you must set and work the PATTERN AT THE SAME TIME. Sometimes the Pattern needles will already be in the 'D' position so you can just leave them there.

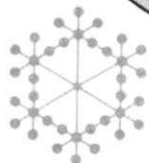

PULLOVER BACK:

With color 1, cast on 151 (165) [179] sts. and work 40 rows K1, P1 Ribbing. Transfer the ribber sts. to main machine and increase 1 st. on the right. Knit 1 row. Leave 12 ((14) [16] sts. on the right in holding position. Begin the Fair Isle Design and DECREASE Short Rows over the remaining sts. FOLLOW THE CHART with numbers as shown for YOUR SIZE. (See Special Instructions). When the DECREASE SHORT ROWS ARE COMPLETED, Leave these needles in holding position - stop Pattern. Go back to the right side, and work Stockinette stitch beginning with 12 (14) [16] sts. and INCREASE SHORT ROWS, then DECREASE SHORT ROWS. Leave these needles in holding position. Break yarn and go back to left side and work INCREASE, THEN DECREASE SHORT ROWS with Stockinette stitch.

After Row 182 (190) [198], SHAPE ARMHOLE: ON EACH SIDE, bind off 4 (5) [6] sts. 2x, 4 sts. 1x, 3 sts. 1x, 2 sts. 1x, 1 st. 7x (8x) [9x].

After Row 274 (283) [302], bind off the center 16 (20) [24] sts., put the needles on the left into holding position and complete the right side first.

*SHAPE SHOULDER AND NECK AT THE SAME TIME.

FOR SHOULDER bind off 4 sts. 3x, 3 sts. 2x (4 sts. 5x) [5 sts. 2x, 4 sts. 3x].

FOR NECK, bind off 6 sts. 4x, 1 st. 2x.

Bring the needles on the left into working position, knit 1 row to the left side, turn the Row Counter back to 274 (288) [302] and complete the left half. Follow the instructions from *.

PULLOVER FRONT:

With color 1, cast on and work same as the back to Row 40. Transfer the ribber sts. to main machine and increase 1 st. on the right. Knit 1 row. Leave 12 ((14) [16] sts. on the right in holding position. Begin the Fair Isle Design and DECREASE Short Rows over the remaining sts. FOLLOW THE CHART with numbers as shown for YOUR SIZE. (See Special Instructions). When the DECREASE SHORT ROWS ARE COMPLETED, Leave these needles in holding position - stop Pattern. Go back to the right side, and work Stockinette stitch beginning with 12 (14) [16] sts. and INCREASE SHORT ROWS, then DECREASE SHORT ROWS. Leave these needles in holding position. Break yarn and go back to left side and work INCREASE, THEN DECREASE SHORT ROWS with Stockinette stitch.

Leave the needles in holding position and change to Fair Isle Pattern and beginning at center with 2 sts. work the INCREASE SHORT ROWS but AT THE SAME TIME, after Row 182 (190) [198], SHAPE ARMHOLE SAME AS THE BACK. After Row 252 (266) [280], bind off the center 16 (20) [24] sts., put the needles on the left into holding position and complete the right side first. Mark PATTERN ROW ON PATTERN SHEET. *ON NECK SIDE, bind off 5 sts. 2x, 4 sts. 1x, 1 st. 12x, BUT AT THE SAME TIME after Row 274 (288) [302] SHAPE SHOULDER same as the back. Set Pattern back to MARKED ROW. Bring the needles on the left into working position, knit 1 row in Pattern to the left side, turn the Row Counter back to 252 (266) [280] and complete the left half. Follow the instructions from *.

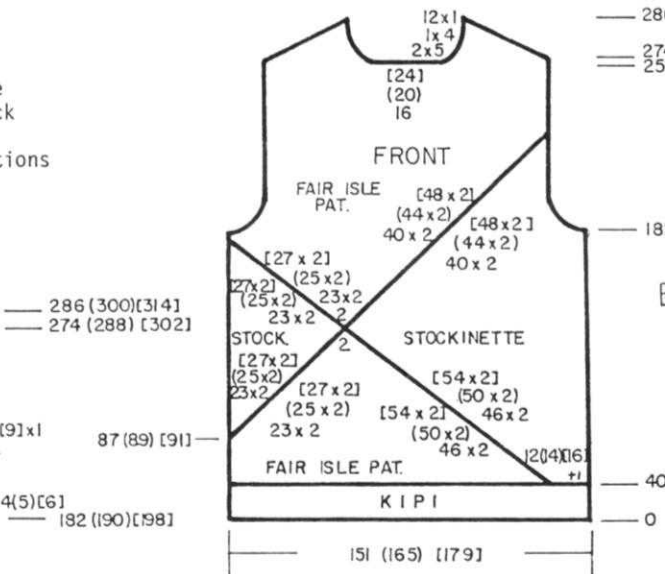
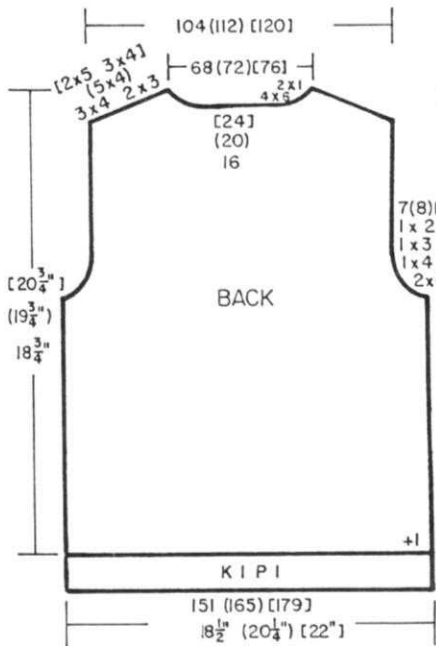

— 286 (300) [314]
 — 274 (288) [302]
 — 252 (266) [280]

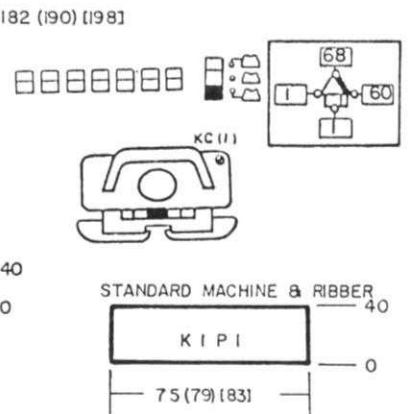

SLEEVE BAND: Standard machine with Ribber - T-0/0 II Cast on 75 (79) [83] sts. with color 1 and work 40 rows K1, P1 Ribbing. Transfer the ribber sts. to main machine knit 1 row, then remove the sts. into contrast waste yarn.

With knit side facing you, hang the open sts. of sleeve back onto the machine - 46 (50) [54] sts. Hang the sleeve band onto these needles, DECREASING evenly across. Bind off LOOSELY.

SLEEVES: BULKY MACHINE-T4.

With contrast waste yarn, cast on 46 (50) [54] sts. Knit 9 to 11 rows then 1 row with Ravel Cord to the right. Counter at 0, change to ANGORA. ON EACH SIDE, increase 1 st. every 10th row 5x. Knit to Row 68 (70) [72].

SHAPE CAP:
 ON EACH SIDE, bind off 3 (4) [5] sts. then bind off 1 st. 3x, 1 st. every 4th row 6x, then every 2nd row 1 st. 6x (7x) [8x]. After Row 112 (116) [120], bind off the remaining sts.

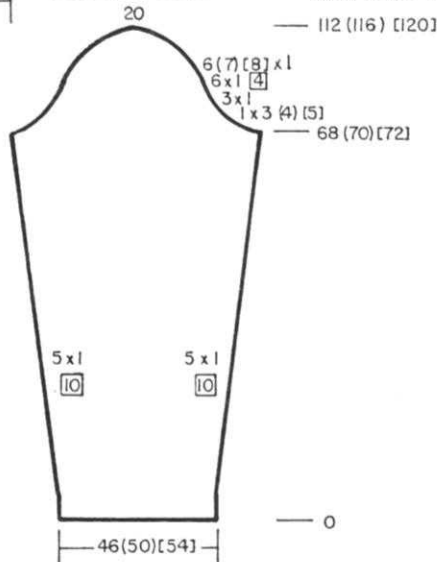

FINISHING: See General Instructions. With Angora, work 2 rows single crochet around neckline.





493

WOMENS PULLOVER

SIZES: 8/10 (12/14)
YARN: BULKY Venetia = color 1
 Angora = color 2
 Isabella for Bow

AMOUNT:
 color 1 1 1/2 lbs. } all
 color 2 3 balls } sizes
 1 ball Isabella

TENSION 1.2 on Bulky Machine
 Rib. 7/7 I

GAUGE: 10.5 sts. 14 rows = 2"

WAISTBAND - MAKE 2

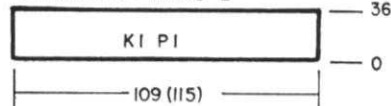

WAISTBAND: Make 2. Color 1

Cast on 109 (115) sts. (Standard Ribber) and work 36 rows K1, P1 Ribbing.

Transfer the ribber sts. to main machine. Remove onto waste yarn.



Can be made on any BULKY Machine with STANDARD Ribber.

Stockinette stitch with Angora crochet around neckline.

Cord Belt and Bow - Trim with Balls and Bells - instructions in this issue.

Knit sideways on the machine.

BACK & FRONT the same.

OPEN CAST ON with waste yarn 20 (24) sts. to the EXTREME LEFT SIDE of machine. After Waste knitting, end with Ravel Cord to the right side.

Counter 0 - Color 1. Work Stockinette stitch. Knit to Row 16 (20).

ON THE RIGHT, increase 1 st. every 3rd row 16x. every 2nd row 21x.

After Row 108 (112) **ON THE RIGHT**, cast on 6 sts. 3x, 7 sts. 2x. (7 sts. 5x).

After Row 140 (146) **ON NECK SIDE**, decrease 1 st. every 4th row 2x, then 1 st. every 2nd row 5x.

Mark each side After Row 184 (192) for center of garment.

After Row 210 (220) **ON NECK SIDE**, increase 1 st. every 2nd row 5x then every 4th row 2x

After Row 250 (262), bind off 7 sts. 2x, 6 sts. 3x (7 sts. 5x).

After Row 260 (272) **ON THE RIGHT**, decrease 1 st. every 2nd row 21x, the 1 st. every 3rd row 16x.

After Row 368 (384) remove the sts. onto contrast waste yarn. Make 2nd section the same.

BOW:

Cast on FULL NEEDLE Ribbing (Standard machine (Tension 2/2 - 12 sts. and work 200 Rows. Transfer the ribber sts. to main machine and knit 1 row over all needles then bind off.

Cast on 3 sts. Set your machine for knitting a Cord and knit till cord is approximately 80" long. Bind off.

CORD FOR BELT: Tension 3 (Standard Machine).

Cast on 3 sts. Set your machine for knitting a Cord and knit till cord is approximately 80" long. Bind off.

BOW

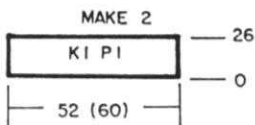
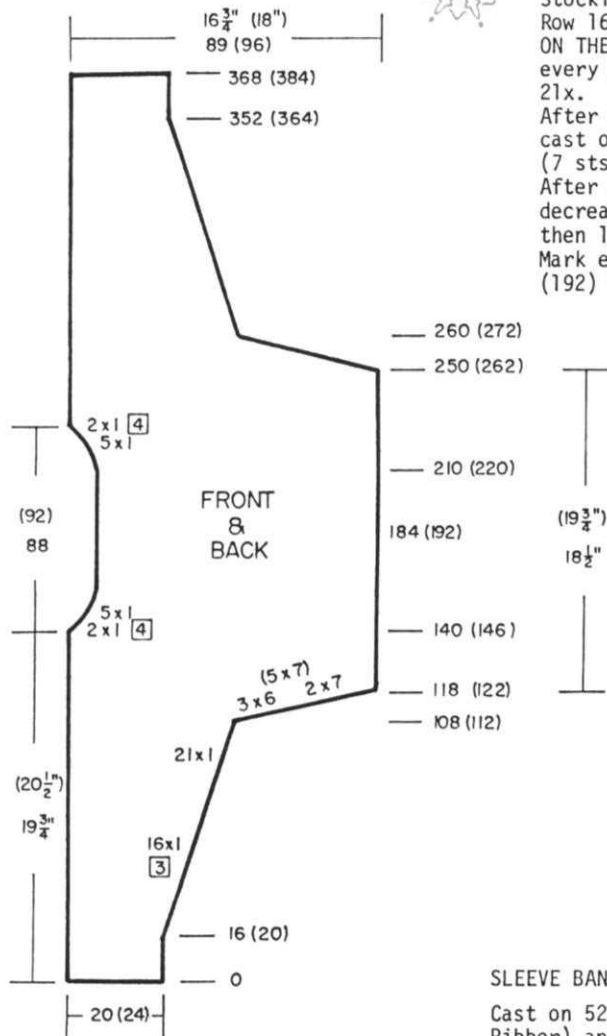
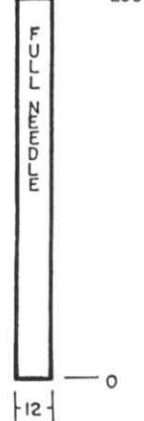

SLEEVE BANDS: Make 2 Color 1

Cast on 52 (60) sts. (Standard Ribber) and work 26 rows K1, P1 Ribbing. Transfer the ribber sts. to main machine. Remove onto contrast waste yarn.

FINISHING: Close Shoulder seams first. With right side facing you, hang open sts. of sleeve onto machine then with wrong side facing you, hang open sts. of sleeve band doubling every 3rd st. Knit 1 very loose row then bind off.

Attach band to waist in the same way as sleeve bands but double every 4th st. of the ribbing. Close side seams. Pull cord through at top of ribbed waistband then attach bells. Make Bow and attach at shoulder with bells (see picture). Crochet ruffle collar as follows: With 2 hook and using Angora, slip stitch around neckline.

Row 2. *Ch 3, skip 2 sts. slip stitch crochet into next st. REPEAT from * around. Join.

Row 3. Slip st. into ch 4 space, ch 3, dc, ch 2, 2 dc into same space.

*ch 2, 2 dc, ch 2, 2 dc in next ch 4 space. REPEAT FROM * around. Join.

Row 4. Slip st. to first ch 2 space. Ch 3, dc, ch 2, 2 dc in same space.

Ch 2 *2 dc, ch 2, 2 dc in next ch 2 space, ch 2, REPEAT FROM * around. Join. ROW 5. REPEAT ROW 4.

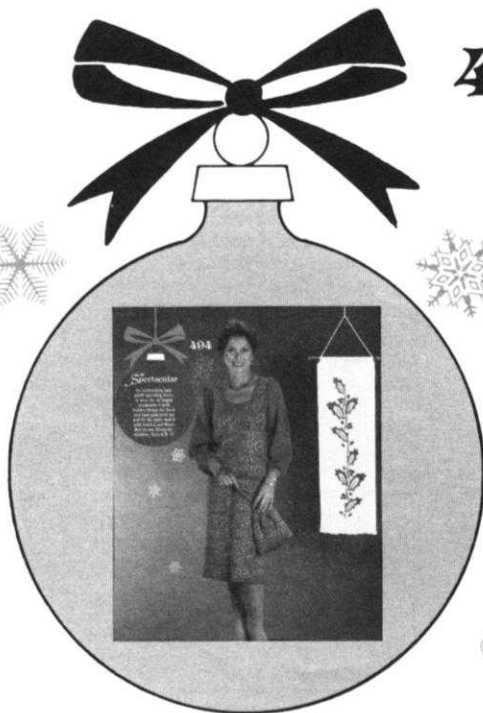

FRONT: Use DOUBLE strands Mami Rex.

Work the front the same as the back to Row 186 (196). Bind off (or remove onto waste yarn) the center 14 (20) sts., put the needles on the left into holding position and complete the right side first.

*ON NECK SIDE, bind off 5 sts. 2x, 3 sts. 2x, 1 st. 6x and after Row 282 (294) SHAPE SHOULDER same as the back. Bring the needles on the left into working position, knit in pattern to the left side, turn the Row Counter back to 186 (196) and complete the left half. Follow the instructions from *.

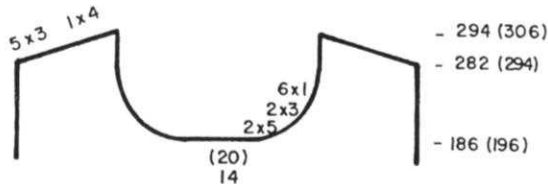

FAIR ISLE PAT. FRONT

NECKBAND: T 3.2/2.2

FULL NEEDLE RIBBING: Cast on 174 (184) sts. with color 1 and work full needle ribbing to Row 14. Transfer the ribber sts. to main machine and after closing 1 shoulder, pick up the sts. around neckline with wrong side facing you then bind off loosely.

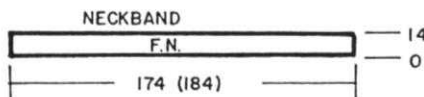

WOMENS TWO-PIECE DRESS

- SIZES: 8/10 (12/14)
- YARN: Venetia and regular Mami Rex
- AMOUNT: color 1 Venetia - 2 lbs. color 2 Mami Rex (USED DOUBLE) 7 SPOOLS
- TENSION: Stockinette T 3.2 Fair Isle T 3
- RIBBING T 3.2/ 2.2
- GAUGE: Stock: 15.5 sts. 28 rows = 2" Fair Isle: 16 sts. 27 rows = 2"
- 8 Buttons. Shoulder Pads.

Made on the KH 910 machine with Ribber. Can be made on any Electronic machine. Stockinette stitch and Fair Isle Design. Bands are Full Needle Ribbing. Send \$1.00 and No. 9 self addressed and stamped envelope for full size copy of Design.

BACK: Use DOUBLE strands Mami Rex.

With color 1, FULL NEEDLE RIBBING, cast on 138 (150) sts. Work 14 rows ribbing then transfer the ribber sts. to main machine. ON EACH SIDE, remove 21 (24) sts. onto contrast waste yarn. Continue in Fair Isle Pattern over the 96 (102) stitches. After Row 282 (294), bind off or remove onto waste yarn, the center 18 (24) sts. Put the needles on the left into holding position and complete the right side first.

*SHAPE SHOULDER AND NECK AT THE SAME TIME.

FOR SHOULDER, bind off 3 sts. 5x, 4 sts. 1x and ON NECK SIDE, bind off 6 sts. 3x, 1 st. 2x.

Bring the needles on the left into working position. Knit in Pattern to the LEFT side then turn the Row Counter back to 282 (294) and complete the left half. Follow the instructions from *.

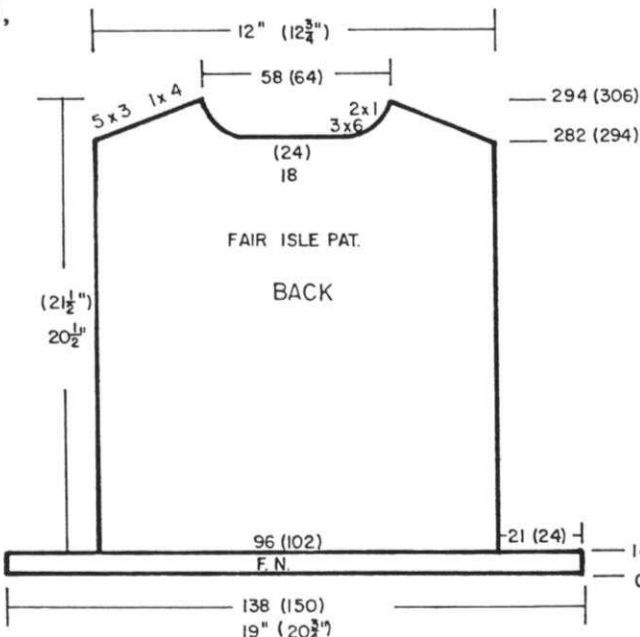
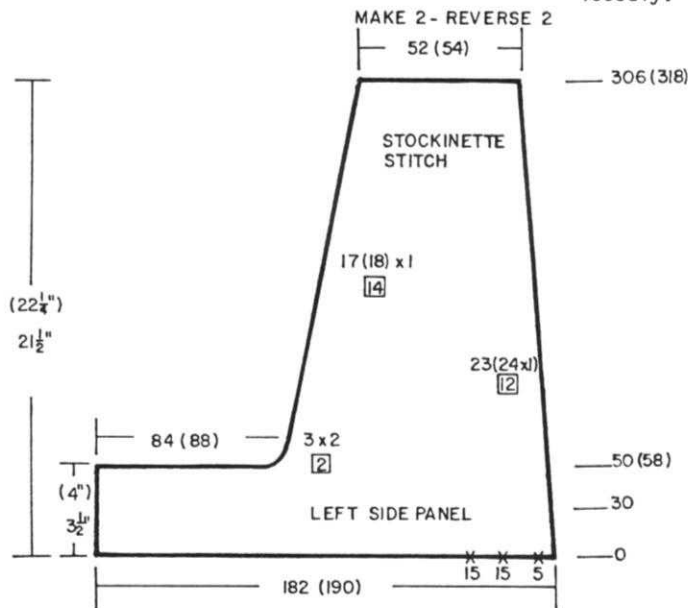

SIDE PANEL AND SLEEVE: Make 2 and reverse 2. Begin and end with contrast waste yarn. LEFT SIDE PANEL: Cast on 182 (190) sts. After Waste knitting, change to color 1 and work Stockinette stitch. Counter 0. After Row 30, begin the decreases on the RIGHT. Decrease 1 st. every 12th row 23x (24x) BUT AT THE SAME TIME, ON THE LEFT, after Row 49 (57) remove 84 (88) sts. onto waste yarn. ON THE LEFT, decrease 2 sts. every 2nd row 3x then 1 st. every 14th row 17x (18x). After Row 306 (318) remove the sts. onto contrast waste yarn. Make 1 more section the same then make 2 with reverse shaping.



continued

SKIRT BACK: 2 strand Mami Rex for Fair Isle.
With color 1, cast on 184 (198) sts. and work 14 rows FULL NEEDLE RIBBING. Transfer the ribber sts. to main machine and continue in FAIR ISLE DESIGN. Knit to Row 338 (354). Remove the sts. onto contrast waste yarn.

SKIRT LEFT FRONT:

With color 1, cast on 106 (113) sts. and work 14 rows FULL NEEDLE RIBBING. Transfer the ribber sts. to main machine and on the RIGHT SIDE, remove 6 sts. onto contrast waste yarn. Continue in FAIR ISLE DESIGN and knit to Row 333 (354) then remove the sts. onto contrast waste yarn. Make the RIGHT FRONT the same but remove 6 sts. on the LEFT onto contrast waste yarn after row 14.

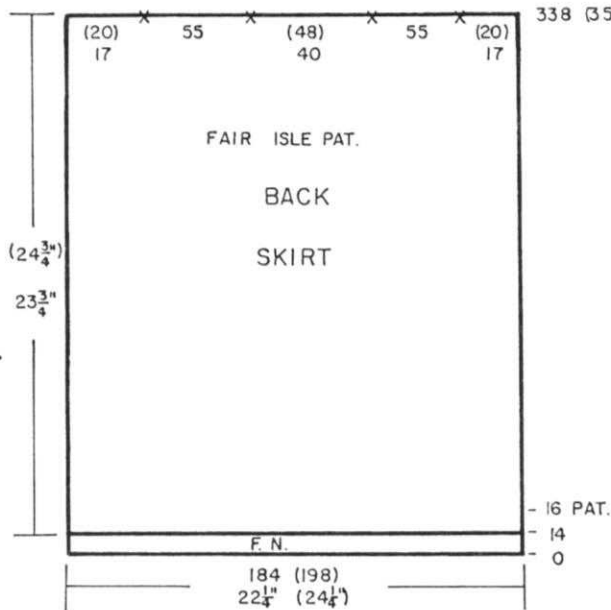

SIDE PANEL FRONT TRIM:

With contrast waste yarn, cast on 162 (170) sts. Knit 9 rows then change to color 1 and knit 1 row to the RIGHT side. With double strand of Mami Rex and Tension 2.2 knit 10 rows Stockinette stitch. Pick up the first row (color 1) and hang onto machine to form hem. LEAVE STITCHES IN THE HOOKS OF NEEDLES. Pull the front sts. through the back sts. Knit 1 row color 1 then remove the sts. onto contrast waste yarn. With RIGHT side facing you, pick up sts. along edge of front section onto 162 (170) needles. With wrong side facing you, pick up the OPEN STS. from Side Panel and hang onto these same needles FORMING 2 PLEATS AT SHOULDER EDGE as shown on the Chart. Knit 1 row then bind off.

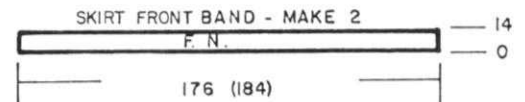
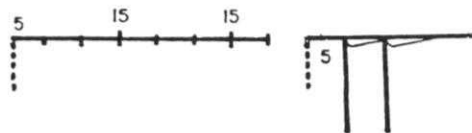
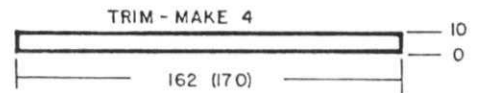
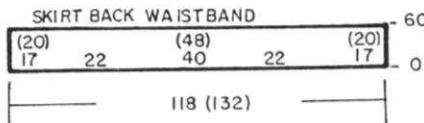
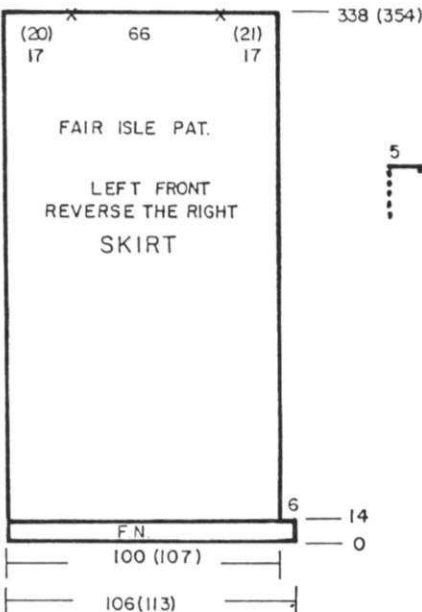

SKIRT BACK WAISTBAND:

With color 1, cast on 118 (132) sts. and work 60 rows Stockinette st. Hang the cast on sts. onto the machine to form hem and with wrong side facing you, pick up the open sts. of skirt back and hang onto the same needles, DOUBLING THE STS. as shown on the Chart. Knit 1 row then bind off.

SKIRT FRONT BANDS - Make 2 BEFORE knitting Front Waistband.

Cast on 176 (184) sts. with color 1 and work 14 rows FULL NEEDLE RIBBING. Transfer the ribber sts. to main machine then with wrong side facing you, hang the front edge of skirt onto these needles with lower edge to meet the 6 open sts. Bind off. Weave the open sts. to band.

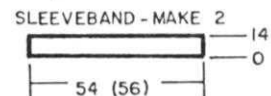

SLEEVE BANDS: Make 2.

OPEN CAST ON 54 (56) sts. with contrast waste yarn same as you did before. After Ravel Cord row to the right side, change to double strands of color 2. Counter at 0. Knit 14 rows Stockinette stitch. Garment must be put together first then pick up sts. around sleeve edge and hang onto these needles with wrong side facing you. Pick up the first row of band to form hem. Bring all the needles to holding position so you can knit 1 row over all sts. then bind off.

SKIRT FRONT WAISTBAND

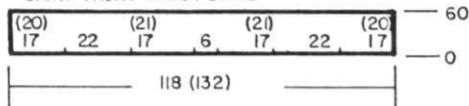

SKIRT FRONT WAISTBAND:

With color 1, cast on 118 (132) sts. and work 60 rows Stockinette stitch. Hang the cast on sts. onto the machine to form hem then with wrong side facing you, hang the 2 sections of skirt front onto these needles. pick up 6 sts. at each front edge band and lapping left over right in the center. Triple up the sts. ON EACH SIDE as shown on the Chart. Bring all needles to holding (E) position so that you can knit 1 row over all sts. then bind off.

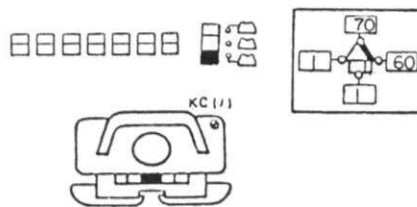

FINISHING: See General Instructions. Insert Elastic through Waistband of Skirt then close openings. Sew front band down on the inside of Skirt then sew on buttons as shown in Picture.



495



WOMENS DRESS

SIZES: 6/8 (10/12)
YARN: Venetia
AMOUNT: 1 1/2 lbs.
TENSION: 4 Stockinette stitch
 5 for Skirt and Sleeve Lace
 4 for Lace on Top and Belt
 6 for Lace on lower edge - Pattern 1.
GAUGE: Stockinette stitch - 16 sts.
 25.5 rows = 2".

Stockinette stitch with Eyelets and Lace. Use 3 Punch Cards.

FRONT:

With contrast waste yarn, cast on 180 (190) sts. Knit at least 2" of waste knitting ending with 1 row Ravel Cord to the right side. LATCH TOOL CAST ON from RIGHT to LEFT. Do not make this cast on too tight or you will not be able to knit the first row. Attach garment yarn at left and Counter at 0. Knit 1 row to the right.

- 458 (476) Work the 12 rows of LACE PATTERN 1 then work 2 more rows Stockinette stitch. After Row 14, work Lace Pattern 2.
 After Row 18, begin Pattern 3.
 After Row 59, ON THE LEFT, bind off 5 sts. every 2nd row 36 (38) times. Bring 160 (170) needles into working position.
 Pick up sts. along bound off edge and hang onto these needles, distributing the knitting evenly across.
 Attach yarn on the right and knit 1 row to the LEFT.
 Continue in Stockinette stitch with SHORT ROWS.
 Bring all the needles on the RIGHT except 4 on the left into holding position. Set Carriage for holding needles.
 Knit 2 rows (wrap inside needle to prevent a hole). Continue to push back 4 sts. 19x more then 5 sts. 16x (18x). After Row 72 (76) ON EACH SIDE, decrease 1 st. every 24th row 5x.

AT THE SAME TIME, WORK LACE PATTERN 3 and Special Eyelets that you will transfer by hand.

Transfer every other st. to the needle ON THE LEFT 9x. Leave the empty needles in working position. Knit 2 rows.

Make 2 eyelets by hand to the left of the 9. Leave empty needles in work. Begin Lace Pattern 3. PUSH SELECTED NEEDLES UP TO AND INCLUDING THE 2 hand made eyelets back to 'B' position before knitting the 2 rows after Lace TRANSFER.

*Make 2 eyelets by hand to the left of the last 2 made before, use Lace Carriage, Push back all selected needles to the LEFT and INCLUDING the last 2 eyelets before knitting the 2 rows after Lace TRANSFER. Continue in this way following the instructions from *

After Row 434 (452) Bind off the center 8 (12) sts., put the needles on the left into HOLDING POSITION A (back against needle bed on ravel cord) and complete the right side first. MARK ROW ON CARD.

*ON NECK SIDE, bind off 5 sts. 1x, 3 sts. 4x, 2 sts. 3x, 1 st. 3x BUT AT THE SAME TIME, after Row 444 (462) bind off 3 sts. 5x, 4 (5) sts. 1x. Bring the needles on the left into working position, Use Lace Carriage at CORRECT ROW ON CARD, knit 1 row to the left and turn Row Counter back to 444 (462) and complete the left half. Follow the neck shaping from *.

BACK:

Work the back the same as the front reversing the SHAPINGS. OMIT THE LACE AT TOP BODICE. Armhole shaping is the same as the front and SHAPE NECK after Row 444 (462). Bind off the center 8 (12) sts., put the needles on the left into holding position A (back against the needle bed on Ravel Cord) and complete the right side first. MARK ROW ON CARD.

*ON NECK SIDE, bind off 6 sts. 1x, 5 sts. 4x. AT THE SAME TIME SHAPE SHOULDER same as the back. Bring the needles on the left into working position. Use LACE CARRIAGE at CORRECT ROW, knit 1 row to the left, turn the Row Counter back to 444 (462) and complete the left half. Follow the instructions from *.

After Row 256 (266) ON EACH SIDE, increase 1 st. every 10th row 3x. After Row 342 (356), Make BUST DARTS ON EACH SIDE - Do NOT COUNT these rows. SHORT ROWS: ON OPPOSITE SIDE OF CARRIAGE, bring into holding position 4 sts. 10x ON EACH SIDE. Bring all the needles back into working position before knitting the next 2 rows. Put Counter to 342 (356).

Knit to Row 352 (366). SHAPE ARMHOLE: ON EACH SIDE, bind off 4 (5) sts. 2x, 4 sts. 1x, 3 sts. 1x, 2 sts. 1x, 1 st. 5x.

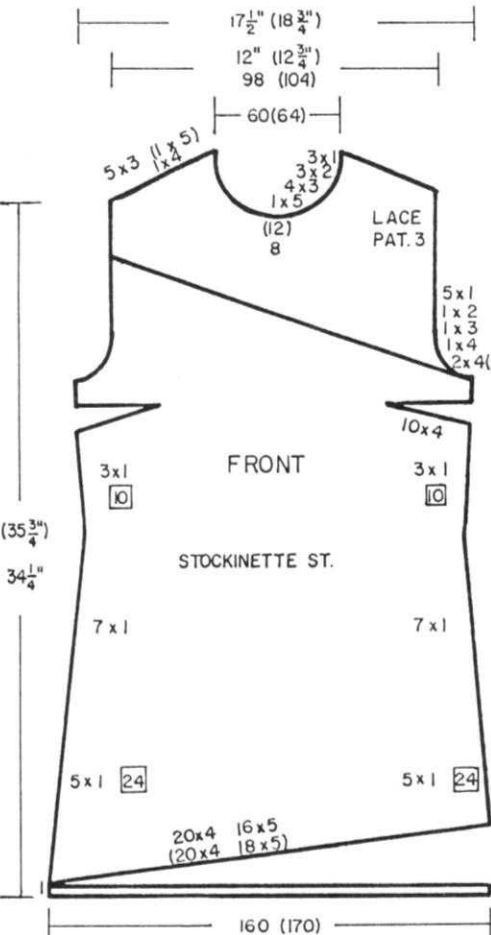

- 458 (476)
 - 444 (462)
 - 434 (452)
 - 352 (366)
 - 342 (356)
 - 342 (356)
 - 256 (266)
 - 72 (76)
 - 2
 - 0

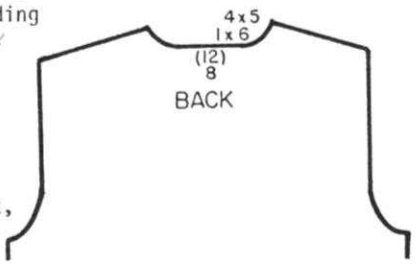
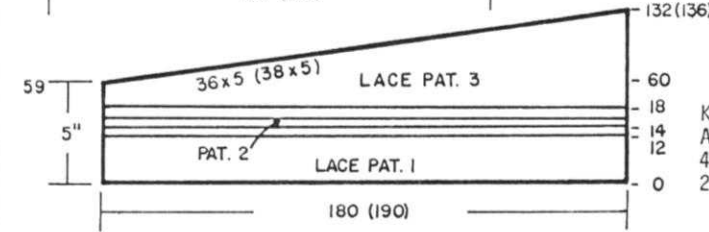

continued

SLEEVES:

Cast on 48 (54) sts.
 Knit 2 rows then work PATTERN 1 to Row 12.
 Work Pattern 2 then Pattern 3 then Pattern 2. Continue Stockinette St. AT THE SAME TIME, ON EACH SIDE, increase 1 st. every 6th row 20x.
 After Row 176 (180) SHAPE CAP: ON EACH SIDE, bind off 4 sts. 1x, 3 sts. 1x, 2 sts. 1x. 1 st. 3x, 1 st. every 4th row 19x (20x) then 2 sts. 5x.
 After Row 274 (282), bind off the remaining sts.

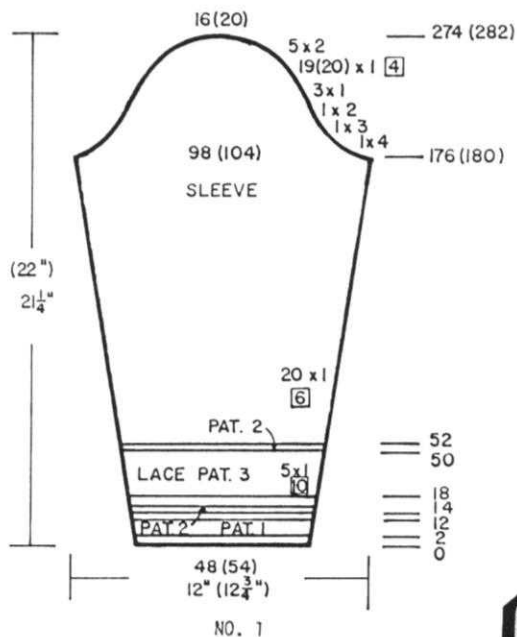

BELT: Make 1 with Lace Pattern and 1 in Stockinette st.

Cast on 14 sts. and work Stockinette stitch to Row 116. Continue in Lace Pattern 3. After Row 176, ON EACH SIDE cast on 2 sts. every 4th row 10x. After Row 216, ON EACH SIDE, Bind off 2 sts. every 4th row 10x. After Row 316, continue in Stockinette stitch to Row 432. Bind off. Make 1 in Stockinette st.

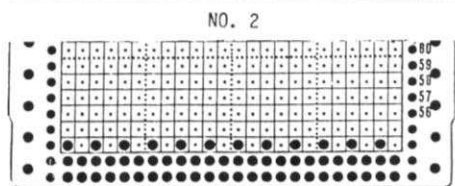
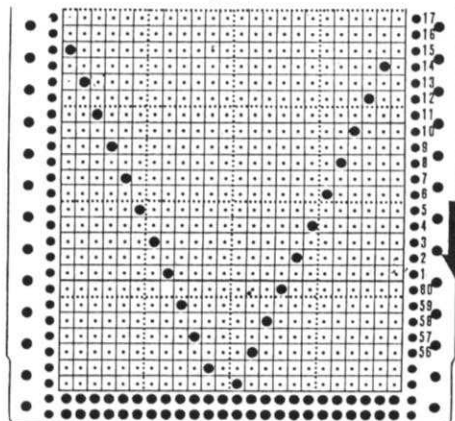
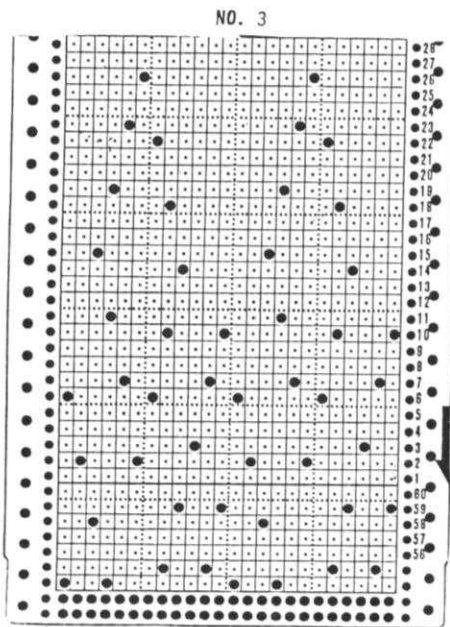
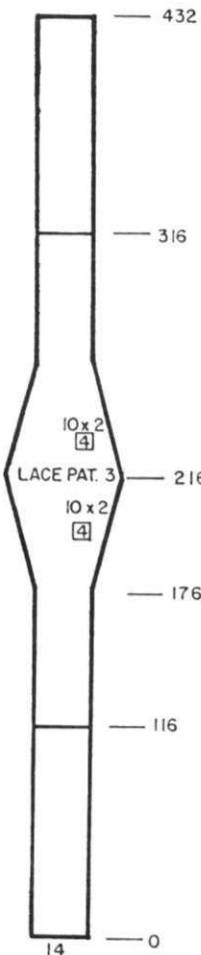

FINISHING: See General Instructions. Work 2 rows single crochet around neckline. Put 2 sections of belt together, wrong side to the inside and work 1 row single crochet around all edges. Sew snaps or clasps to the inside of belt for closure. Work 2 rows single crochet around Sleeve edges.

KNITKING introduces

The Twister

A two-way Winder.

Twist your way to multi-color garments... Create your own original yarns by twisting your own selection of colors and textures. It will also wind a single strand of yarn into a ball.

with Twister

without Twister

PRICE: \$27.95—California residents add Sales Tax. SHIPPING costs—\$2.50

Order direct from your dealer or from: KNITKING, 1128 Crenshaw Blvd., Los Angeles, Calif. 90019

496

MENS 'V' NECK PULLOVER

SIZES: 38/40 (42/44) [46]

YARN: VENETIA

AMOUNT

color 1 8 oz. 8 oz. 10 oz.

color 2 8 oz. 8 oz. 10 oz.

TENSION: KH 891 - T 4,1

GAUGE: 17 sts. 24 rows = 2"

TENSION: KG 89 - T 5

GAUGE: 15 sts. 20 rows = 2"

Rib. T 1

Body of Pullover is knitted on the Standard machine and is worn on the Purl side. Sleeves are knitted with KG 89 Garter Carriage. Crochet the Neckband. Punch Card for Sleeve.

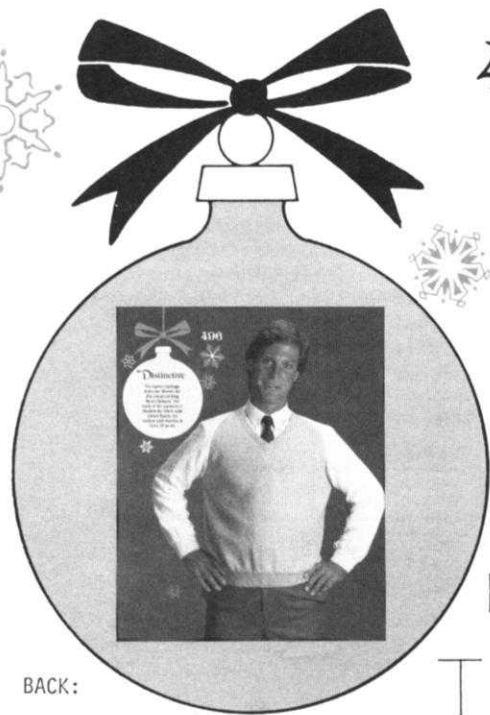

BACK:

OPEN CAST ON WITH WASTE YARN, 171 (181) [191] sts. Knit 9 to 11 rows then 1 row Ravel Cord to the right side.

Change to garment yarn, color 1 and Counter at 0. Work Stockinette stitch.

ON EACH SIDE increase 1 st. every 40th row 3x.

After Row 148 (154) [160], SHAPE ARMHOLE: ON EACH SIDE, bind off

5 sts. 1x, then ON EACH SIDE WORK FULL FASHION DECREASES EVERY 2ND ROW. Use double transfer tool and remove the 2 end sts. and move to the 3rd needle.

1 st. 59x (62x) [65x].

After Row 266 (278) [290], remove the remaining sts. onto contrast waste yarn.

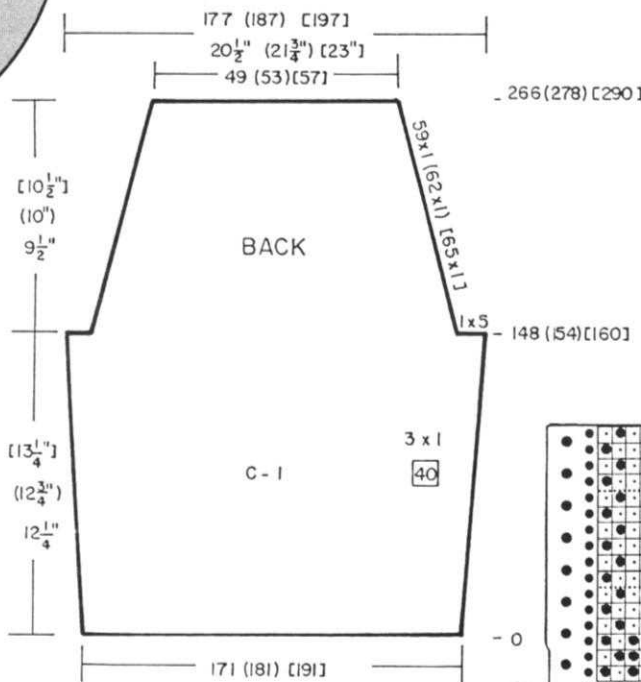

REPEAT the Punch Card through Row 41 then punch 2 rows of holes for connecting Card.

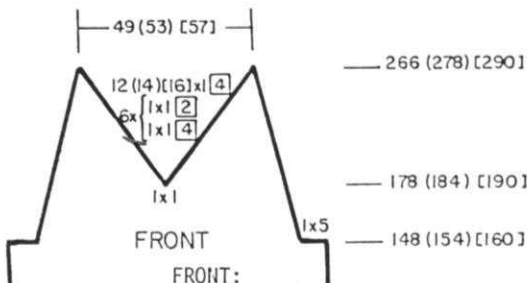

Work the front the same as the back to Row 148 (154) [160]. SHAPE ARMHOLE SAME AS THE BACK BUT AT THE SAME TIME, after Row 178 (184) [190], divide in the center. Hang the center st. to neighboring needle and put the needles on the left into holding position. Complete the right side first.

*ON NECK SIDE, decrease 1 st. FULL FASHION every 4th row 1x, every 2nd row 1x and ALTERNATE these decreases 6x IN ALL, THEN ON NECK SIDE, decrease 1 st. every 4th row 12x (14x) [16x].

Bring the needles on the left into working position. Knit 1 row to the left side, turn the Row Counter back to 178 (184) [190] and complete the left half. Follow the instructions from * and don't forget to complete the raglan shaping at the same time.

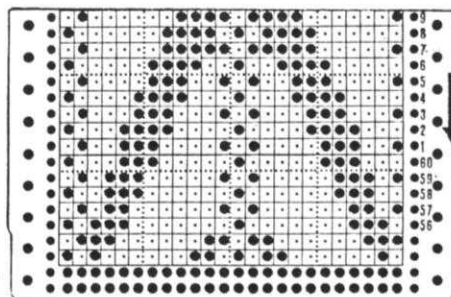

SLEEVE BANDS:- KG 89 GARTER CARRIAGE

Cast on 69 (77) [81] sts. with color 2 and work 30 rows K1, P1 Ribbing. Hang the open sts. of sleeve onto these needles, decreasing evenly across (place 1 st. on 1 needle, then 2 sts. on next needle - etc.) Knit 1 very loose row then bind off.

WAISTBAND - MAKE 2

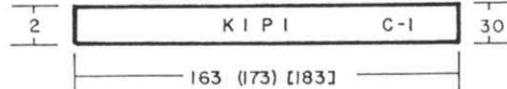

WAISTBAND: - KG 89 GARTER CARRIAGE

Cast on 163 (173) [183] and work 30 rows K1, P1 Ribbing. Hang the open sts. from waist onto these needles, decreasing evenly across. Knit 1 very loose row then bind off.

FINISHING: See General Instructions. With No. 3 crochet hook, work 1 row single crochet around neckline with color 1 then work 3 rows double crochet and 1 row slip stitch. Mitre the V shaping.

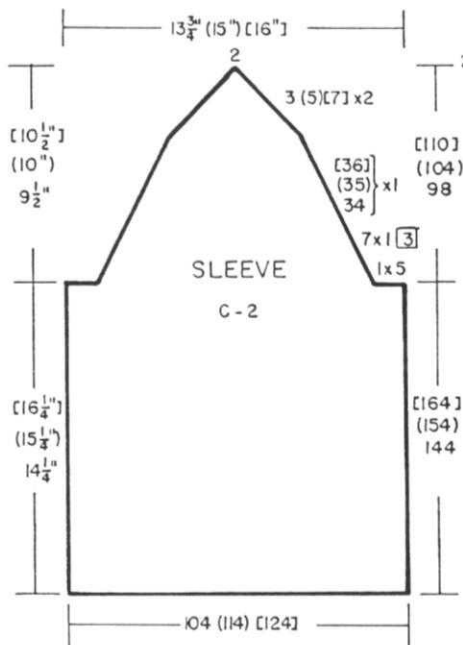

SLEEVES: - KG 89 GARTER CARRIAGE

The INSIDE numbers on the Chart are for the NUMBER SETTINGS FOR THE GARTER CARRIAGE. The OUTSIDE numbers are Row Counter numbers.

OPEN CAST ON same as front and back 104 (114) [124] sts. After waste knitting, put Counter at 0 and with color 2, knit in Pattern to Row 144 (154) [164]. SHAPE ARMHOLE: ON EACH SIDE, bind off 5 sts. 1x, then work FULL FASHION ON EACH SIDE, same as before. 1 st. every 3rd row 7x, 1 st. every 2nd row 34x (35x) [36x] then 2 sts. 3x (5x) [7x]. After Row 242 (258) [274], bind off the remaining 2 sts.

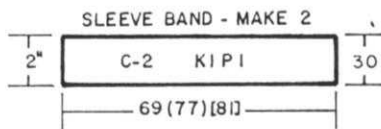

497

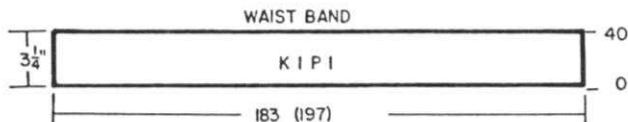

WAISTBAND: Make 2.

K1, P1 RIBBING: Cast on 183 (197) sts. and work ribbing to Row 40. Transfer the ribber sts. to main machine then hang the open waist sts. onto these needles, picking up an extra stitch from waist edge after every 3rd stitch to hang onto 4th needle. Knit 1 row then bind off LOOSELY.

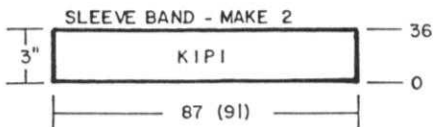

SLEEVE BAND: Make 2.

K1, P1 RIBBING: Cast on 87 (91) sts. and work ribbing to Row 36. Transfer the ribber sts. to main machine. Hang the open sts. of sleeve onto these needles doubling the sts. as needed. Knit 1 row then bind off.

SLEEVE:

Begin at ARMHOLE EDGE.

Cast on FULL NEEDLE RIB same as you did for front and back. Knit in ribbing to Row 34. Transfer the ribber sts. same as before then continue in Special Rib Pattern. ON EACH SIDE, on EVERY 12th row, decrease 2 sts. 11x (12x) in the following way. With double transfer tool remove the 2 END STS. ON MAIN MACHINE and move them in on top of needle 3 and 4. DROP OFF 2 Ribber sts. ON EACH SIDE (these will ravel down) Continue the decreases each time in the same way. After Row 194 (204) DROP all the RIBBER STS. and knit 1 row over the remaining needles on main machine. Remove onto contrast waste yarn.

MENS PULLOVER

SIZES: 40/42 (44/46)
 YARN: Beatrice
 AMOUNT: 10 11 balls
 TENSION: 3/3 I for SPECIAL PATTERN
 3/3 II for K1, P1 Ribbing
 GAUGE: 13 sts. 19 rows = 2" (5 cm)

Can be made with any Punch Card machine or KH 910 Electronic with KR 900 RIBBER ONLY. Bands are K1, P1 Ribbing.

IMPORTANT: NEEDLE ARRANGEMENT - The LEFT END NEEDLE of Ribber MUST be placed DIRECTLY on the top red mark shown on the Needle Number Strip of the RIBBER. The RIGHT END NEEDLE of Ribber MUST be placed BETWEEN the red marks of the Needle Number Strip of Ribber.

PATTERN STITCH.

Cast on the required number of stitches on BOTH BEDS being sure the arrangement is as given above. After the FULL NEEDLE RIBBING is completed as per instructions, transfer the ribber sts. to the main machine.

1. Raise Ribber needles to 'B' position.
2. Knit 1 row.
3. Turn BOTH KR CHANGE KNOBS toward the OUTSIDE.
4. Move the SLIDE LEVER to the CENTER position.
5. LEFT and RIGHT PR LEVERS UP. Knit the specified number of rows as given in pattern. Push RIBBER needles to E position (up) then bring all ribber needles DOWN to A position. (out of work). All the Ribber sts. DROP. Pull the knitting DOWN to unravel the rib stitches.

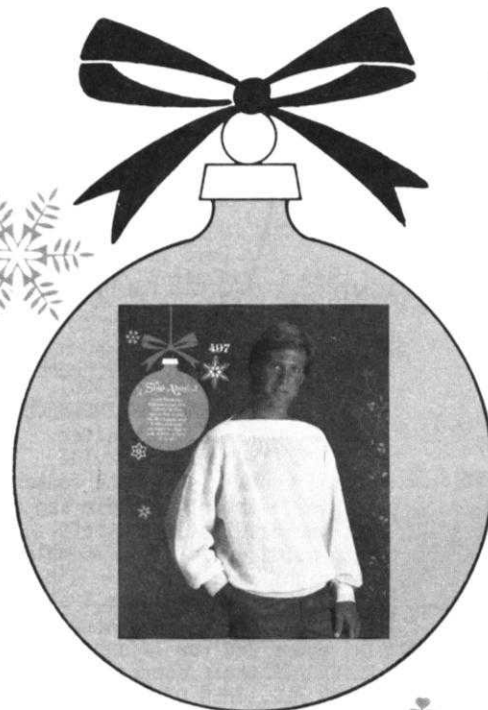

BACK & FRONT THE SAME

Begins at Neck Edge. FULL NEEDLE RIBBING. Cast on 137 (149) sts. (CHECK NEEDLE ARRANGEMENT) Work FULL NEEDLE RIBBING T 3/3 II to Row 34. Transfer the Ribber sts. to Main Machine. Change Tension to 3/3 I and FOLLOW THE PATTERN STITCH INSTRUCTIONS FROM 1 to 5. ON EACH SIDE, Mark row 122 (128) for setting in sleeves. Continue in Pattern to Row 236 (254). Knit 1 row over the sts. on Main machine after you drop the Ribber sts. then remove onto contrast waste yarn.

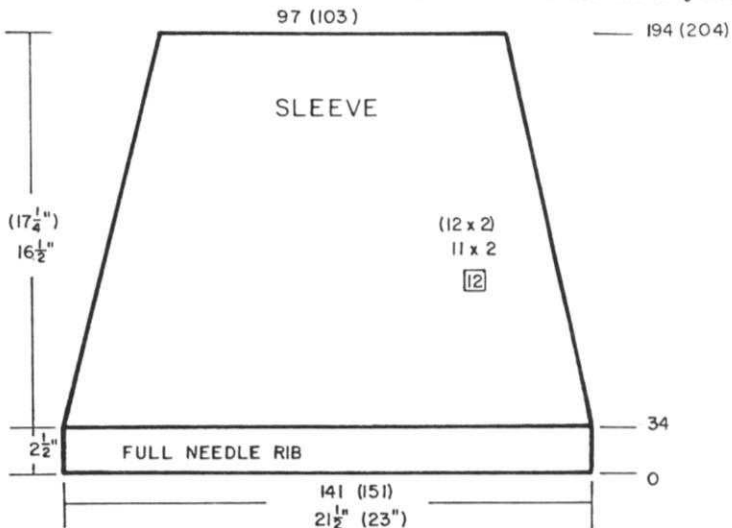
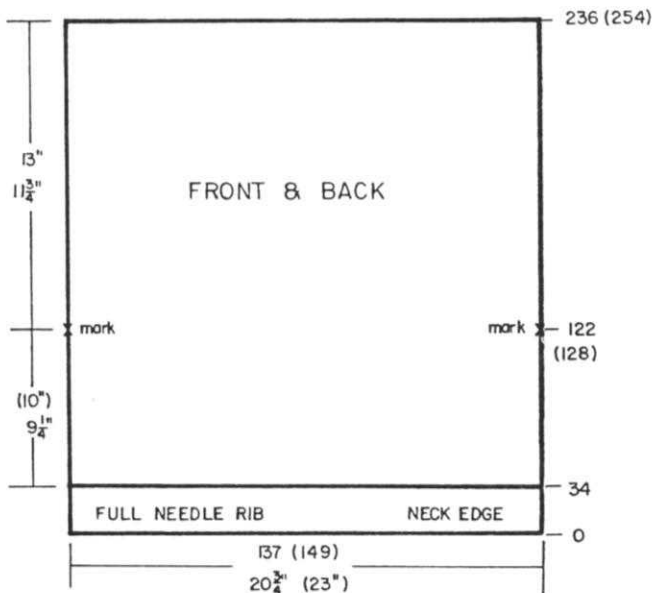

FINISHING: See General Instructions. Close shoulders leaving approximately 10" (10 1/2") open for neck. Attach Sleeves from mark to mark on front and back.

498

BEAR PULLOVER

SIZE: 22" to 24"
 YARN: Alanda
 AMOUNT:
 color 1 3 balls
 color 2 1 ball
 TENSION: 10 - Rib. 6/6 I
 GAUGE: 13 sts. 18 rows = 2"

Stockinette stitch with Fair Isle Design on the front section. Punch Card. Bands and sleeves are K1, P1 Ribbing.

FRONT:

With color 1, cast on 73 sts. and work 20 rows K1, P1 Ribbing. Transfer the ribber sts. to main machine and continue in Stockinette stitch. Increase 1 st. on the right. After Row 50, work the Fair Isle Design one time only. After Row 92, bind off (or remove onto waste yarn) the center 30 sts. *Work short rows or bind off ON NECK SIDE, 3 sts. 4x, 2 sts. 5x. Bring the needles on the left into working position, knit 1 row to the left, turn the Row Counter back to 92 and complete the left half. Follow the instructions from *.

SLEEVES:

Cast on 75 sts. with color 1 and work 66 Rows K1, P1 Ribbing. Transfer the ribber sts. to main machine then with wrong side facing you, pick up sts. along side edge from beginning of pattern on the front to marked row on the back. Bring all the needles to holding position and knit 1 row over all needles then bind off loosely.

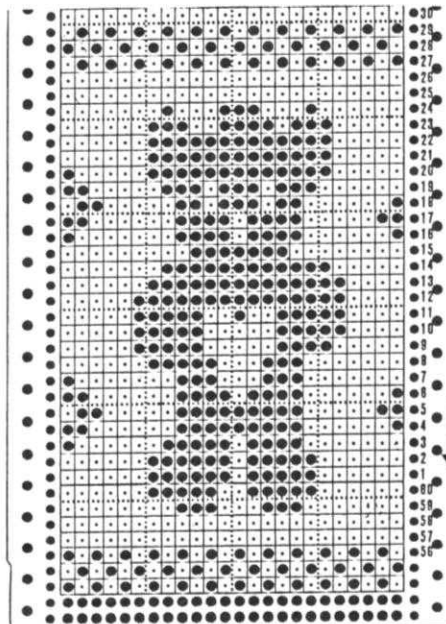

BACK:

Work the back the same as the front but OMIT the Design. Mark Row 50 ON EACH SIDE for setting in sleeves.

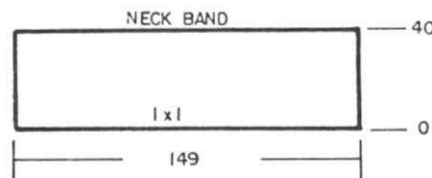
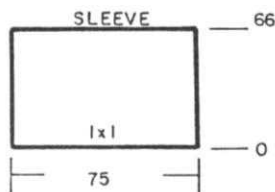
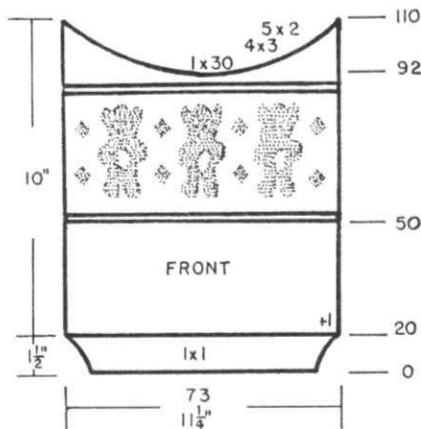
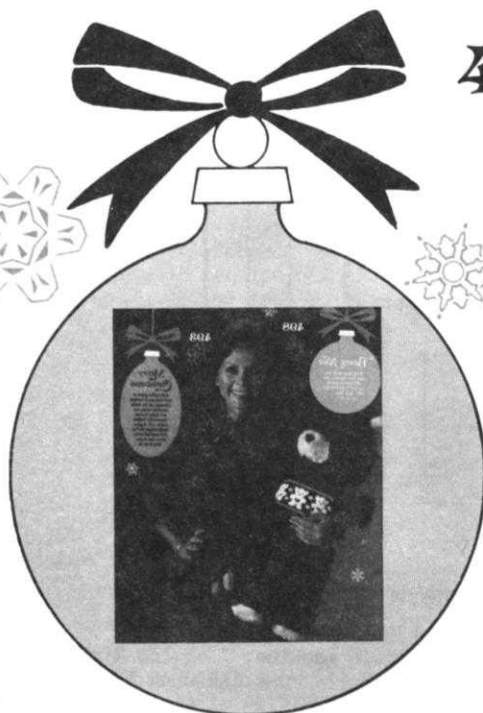

NECKBAND:

With color 1, cast on 149 sts. and work 40 rows K1, P1 Ribbing. Transfer the ribber sts. to main machine then pick up the sts. evenly around neck. Knit 1 row over all sts. then bind off loosely.

FINISHING: See General Instructions.

IT'S READY NOW!

KNITTING MAGAZINE BOUND VOLUME 19

- HARD BOARD COVER
- COMPLETE INSTRUCTIONS
- WILL HOLD ANOTHER COMPLETE VOLUME

PRICE \$23.95
 Shipping Costs \$3.25



RUFFLED COLLAR -Close both shoulders.

FULL NEEDLE RIBBING: Set Ribber to HALF PITCH. Tension 6/6 II. Cast on 160 (166) sts. Knit 9 rows. Transfer every other st. from ribber to Knitter (CHANGE TO NORMAL PITCH ON RIBBER FIRST). Transfer every other st. from KNITTER to Ribber. Work K1, P1 Ribbing with tension 5/5 II. Knit 2 rows, change tension to 4/4, knit 2 rows, change tension to 3/3, knit 2 rows, change tension 2/2 knit 2 rows. Transfer the ribber sts. to the main machine onto the working needles (not empty needles). Knit 1 row then remove the sts. onto contrast waste yarn. Bring 69 (77) needles into working position and hang the sts. held on waste yarn back onto these needles, doubling approximately every 5th st. With purl side facing you, pick up the sts. around neckline and hang onto these needles. Knit 7 rows Stockinette stitch then pick up the first row of Stockinette stitch to form hem and bind off.

REPEAT the Punch Card 1 time more then punch 2 rows of holes for connecting card.

(29) 25 ← 0 → 20 LEFT FRONT
20 ← 0 → 25 (29) RIGHT FRONT

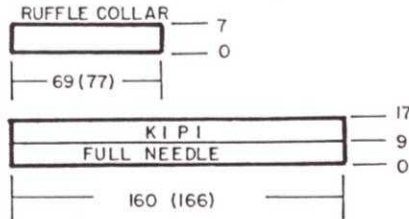

SHOULDER RUFFLE
MAKE 2

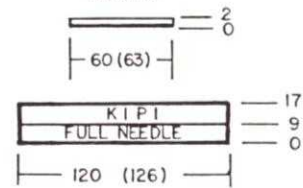

SHOULDER RUFFLE: Make 2.

FULL NEEDLE RIBBING: Cast on 120 (126) sts. and work exactly the same as Ruffled Collar but decrease the sts. to 60 (63) sts. (See Chart) Knit 2 rows then remove the sts. onto contrast waste yarn. Be sure collar is put on first. With right sides facing, Pin ruffle to armhole with straight edge of ruffle to straight edge of armhole. Slip stitch crochet ruffle to armhole then attach small edge of ruffle to shaped armhole edge.

FINISHING: See General Instructions. Sew on Button and Buttonhole bands. Finish Buttonholes and sew on Buttons. Embroider flowers down front section (See Picture).

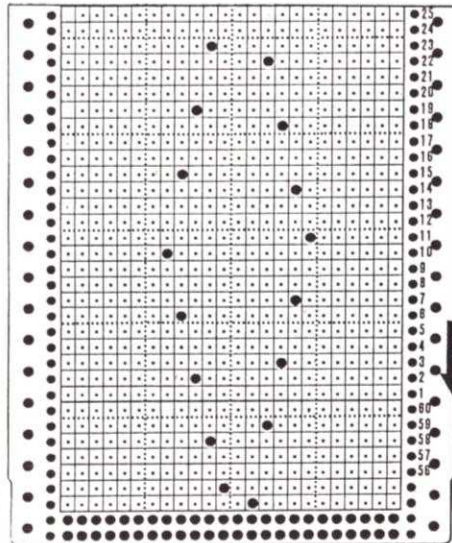

500

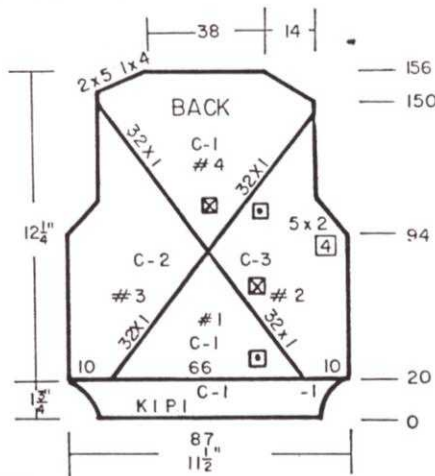

BACK:

With color 1, cast on 87 sts. Work 20 rows K1, P1 Ribbing. Transfer the ribber sts. to main machine and continue as follows: Decrease 1 st. on the right side. WORK SHORT ROWS: Put 10 sts. ON EACH SIDE, into holding position and continue over the center 66 sts. with color 1. ON OPPOSITE SIDE OF CARRIAGE, put into holding position 1 st. 32 x ON EACH SIDE and be sure to ALWAYS WRAP THE INSIDE NEEDLE IN HOLDING TO PREVENT A HOLE. Put the remaining 2 sts. into holding position. Put Counter at 20.

ON THE RIGHT SIDE, bring 10 sts. back into working position and work the INCREASE SHORT ROWS. With color 3, bring back 1 needle to working position every 2nd row 32x as shown on the chart. Work the DECREASE SHORT ROWS every 2nd row same as before BUT AT THE SAME TIME, after Row 94, ON ARM SIDE, make FULL FASHION decreases - 2 sts. every 4th row 5x. When the decrease short rows are completed, leave the needles in holding position. Put Counter at 20. Work the LEFT SIDE in the same way with color 2 (SEE CHART). When the decrease short rows are completed, leave the needles in holding position. Push the center 2 sts. into work and work the INCREASE SHORT ROWS with COLOR 1 till all needles are in work. After Row 150, SHAPE SHOULDER. ON EACH SIDE, bind off (or you can use short rows) 5 sts. 2x, 4 sts. 1x. After Row 156, bind off or remove onto waste yarn the remaining 38 sts.

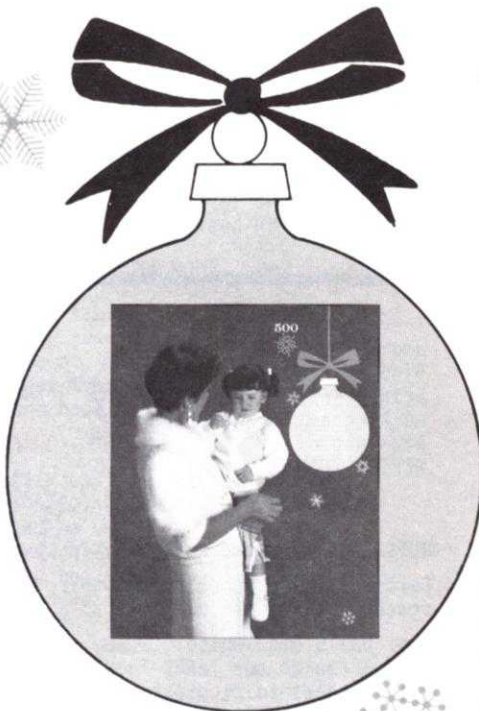

BOY OR GIRL INFANTS CARDIGAN

SIZE: 9 to 16 months
YARN: Daisy
AMOUNT:
color 1 3 balls
color 2 1 ball
color 3 1 ball
TENSION: 6 Rib 1/1, 1 II
GAUGE: 15 sts, 22 rows = 2" (5 cm)

Short Rows are used for the Design with bands in K1, P1 Ribbing.

continued

RIGHT FRONT:

With color 1, cast on 43 sts. and work 20 rows K1, P1 Ribbing. Transfer the ribber sts. to main machine.
 Put 10 sts. on the right into holding position and work the DECREASE SHORT ROWS with color 1 as shown on the Chart (same as you did for the back) 32x on the right.
 Put Counter at 20 and bring 10 sts. on the right into work then with color 3, WORK THE INCREASE SHORT ROWS.
 Work the DECREASE SHORT ROWS as shown but AT THE SAME TIME after Row 94, SHAPE ARMHOLE same as you did for the back. When the decrease short rows are complete, Bring 1 st. on the left into working position and with color 1, work the INCREASE SHORT ROWS BUT AT THE SAME TIME, after Row 139 SHAPE NECK. Bind off 5 sts. 2x, 3 sts. 1x, 2 sts. 2x, 1 st. 2x and AT THE SAME TIME, after Row 149, WORK SHORT ROWS FOR THE SHOULDER SHAPING on the right side same as the back. Knit 1 row over the shoulder st. and bind off or remove onto contrast yarn. MAKE LEFT FRONT WITH REVERSE SHAPING.

SLEEVES:

with color 1, cast on 53 sts. and work 26 rows K1, P1 Ribbing. Transfer the ribber sts. to main machine and increase 1 st. on the right side.
 Continue in color 1.
 ON EACH SIDE, increase (full fashion) 1 st. every 9th row 12x.
 After Row 130, ON EACH SIDE, work FULL FASHION DECREASES - 2 sts. every 4th row 5x.
 After Row 148, bind off.

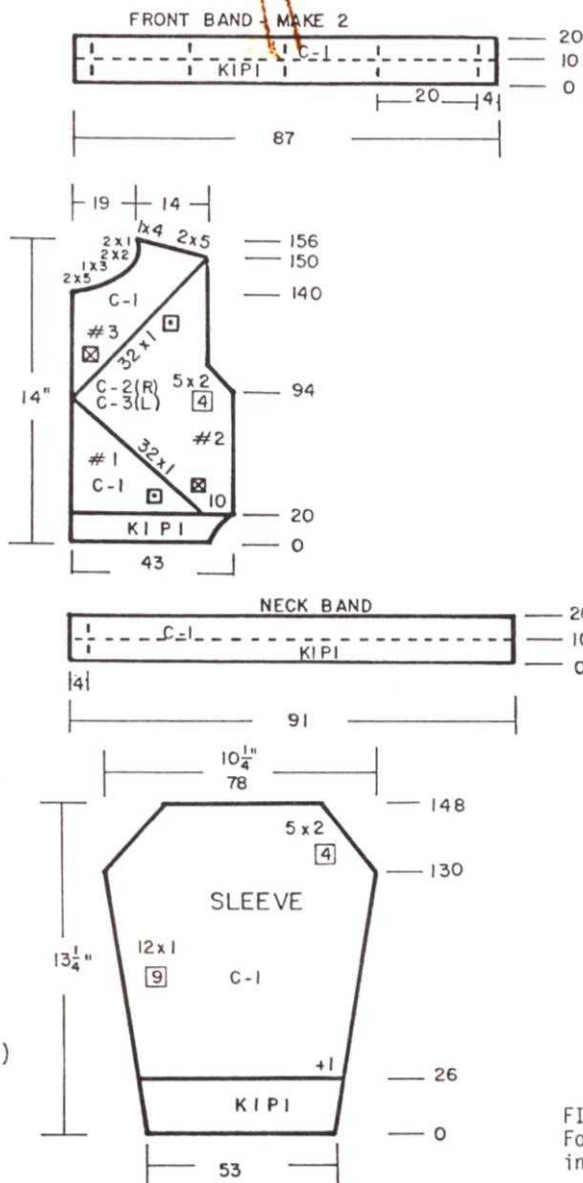

FRONT BANDS: Make 2.

Knit the front hands before knitting the neckband. Cast on 87 sts. with color 1 and work K1, P1 Ribbing. After Row 5 make BUTTONHOLES. Leave 4 sts. on the right make buttonhole over the st. on main machine and ribber but knitting them with a piece of contrast yarn (be sure it is long enough for you to pull down between the beds so you can hold onto it for the next row. Make the following buttonholes in the same way with 20 sts. between each one. Continue in Ribbing to Row 15 then REPEAT THE BUTTONHOLES over same needles as before. After Row 20, transfer the ribber sts. to main machine. Hang the right front onto these needles with purl side facing you and bind off.

Make Button band in the same way but omit the buttonholes.

NECK BAND: Make front bands first.

Cast on 91 sts. with color 1 and work K1, P1 Ribbing. After Row 5, make one buttonhole on the left same as you did for the front over needle 4. After Row 15, REPEAT THE BUTTONHOLE.

After Row 20, Transfer the ribber sts. to main machine then pick up sts. from neck (sew shoulders first) with purl side facing and hang onto these needles. Bind off.

FINISHING: See General Instructions. Fold bands to the inside and sew in place. Sew on buttons.

DOLL ORNAMENTS

YARN: Amore for body and hair
 Any fine yarn such as Roma for clothing.
 Flesh or pink Amore for body arms and legs - small amount.
 Navy for boys pants - Use Amore.
 Red and White for sweater - Roma
 Brown Amore for hair
 Girl: - White Roma for Skirt and red and white for sweater
 Yellow Amore for hair
 Tension: 4
 GAUGE: 16 sts. 24 rows = 2" with Amore.

BODY FOR BOY OR GIRL

With flesh color, 'e' cast on 17 sts. (tension 4 - Amore)
 Knit 34 rows Stockinette st.
 Remove the sts. onto end of yarn and pull up.
ARMS: TENSION 2 - Amore
 'e' cast on 4 sts.
 Knit 4 rows
 *Put the LEFT END NEEDLE into holding position - knit 5 rows and ALWAYS wrap this end needle Carriage on the LEFT.



Put back the end needle and knit 1 row to the right.
 REPEAT FROM * 3x more (Row 28)
 Hang the sts. together and bind off. Make second arm the same.

LEGS - Same as Arms but if you like you can knit the first 4 rows and cast on with brown or different color to make feet.
 Work the same as arms to Row 58 and bind off the same way.

HAIR: Amore TENSION 2
 Cast on 30 sts. and work stockinette stitch.
 20 rows for boy
 30 rows for girl
 Press firmly and allow to dry over night.

BOYS PANTS - Amore - Ten. 4

'e' cast on 22 sts.
 Knit 12 rows.
 Divide in the center.
 Remove 1 st. in the center left side and put on pin.
 Put the remaining sts. on the left into holding position.

Increase 1 st. ON EACH SIDE and knit 20 rows for leg. Bind off.
 Bring the left side sts. into working position and replace st. on pin.
 REPEAT FROM * TO *.

BOYS SWEATER: Roma - Ten. 3

Card No. 1 - punched every other space. Leave Card on STOP.
 Cast on 15 sts. white.
 Knit 1 row to the left.
 Set Pat left to right, push in MC and put red in B Feeder.
 Knit 4 rows.
 Cast on 5 sts. beginning next 2 rows.
 Knit 6 rows.
 Bind off the center 7 sts. (use a separate piece of yarn) then immediately cast on over the 7 needles with same strand of yarn - you can crochet the sts. onto the needles if you like.
 Knit 6 rows.



Bind off 5 sts. beginning the next 2 rows.
Knit 4 rows then STOP Pattern.
With white, knit 1 row then bind off with white.

GIRLS PANTS: - Roma - Ten. 4

With white, 'e' cast on 22 sts.
Knit 14 rows.
Bind off.
Sew seam at back. Sew about 3/8" in center for legs.
Run yarn or thread elastic around at waist. Put pants on doll and pull up at waist to fit and tie off.

GIRLS SKIRT - Roma - Ten. 4

Open cast on with waste yarn 12 sts. Knit 5 rows then change to white Roma and put counter at 0. Carriage on right.
Knit 2 rows.
* Put 4 sts. on left into holding position. Knit 4 rows, each time wrapping the inside needle in holding position.
All needles in work,
Knit 2 rows .
REPEAT FROM * to ROW 92.
Remove onto contrast waste yarn. Weave the open sts. of skirt together or you can hang the open sts. back onto machine and bind them off. The PURL side is the RIGHT SIDE.

GIRLS SWEATER - Roma - Ten. 3

With red, cast on 18 sts.
Knit in Stockinette stitch.
Knit 6 rows.
Cast on 5 sts. beginning next 2 rows.
Knit 8 rows.
Bind off center 7 sts. and immediately cast on LOOSELY (use separately yarn to bind off and cast on.
Knit 6 rows.
Bind off 5 sts. beginning next 2 rows.
Knit 6 rows. Bind off.

FINISHING:

BODY: Sew long seam and have it at one side.
Stuff with cotton or fibre fill. Measure about 1" down from top and tie strand of yarn around to form head. Close lower body opening. Wrap arms and legs around a knitting needle in a spiral. Steam well with steam iron or hold over steam in tea kettle. Allow to dry thoroughly then sew arms and legs in place.
Embroider french knots for eyes or make a small straight st.
Make straight stitch with red for mouth.

Unravel the piece you knitted for hair and loosely wind around fingers approximately 14 times for boy, then using matching thread sew on head.
For girl, wrap yarn around a 2" cardboard about 24 times. Tie one end and cut other end. Sew to head with matching thread then trim hair.
SWEATERS - Overcast the seams with yarment yarn. For girls crochet around neck and lower edge with white or trim any way you wish. Slipstitch around neckline of boys sweater.
BOYS PANTS; Close back and leg seams. Put on boy and if needed, run yarn around at waist and pull up and tie.
Put skirt on girl and use elastic thread or yarn to run around waist and pull up and tie.



CHRISTMAS POTPOURRI



Pretty ornaments for you to make and each one takes only a small amount of whatever yarn you want to use. We used different colors of a glitter yarn called Isabella and some Roma. We used either tension 3 or 4.. The basic instructions are given but you can use your imagination - changing colors as you wish. The frames are found in Needlepoint shops or even some fabric stores...or you can make some of your own with cardboard. The Jars can be found in most food markets. Be creative and have fun.

BALL - Tension 3

OPEN CAST ON with waste yarn 16 (20) [24] sts. for small, medium or large size. Knit several rows with waste yarn and end on the LEFT side. Counter at 0. change to ornament yarn.
Knit 1 row.
* WORK SHORT ROWS. On opposite side of carriage, put into holding position 1 st. 4x ON EACH SIDE. Be sure to wrap inside needle in holding to prevent a hole.
ON OPPOSITE SIDE OF CARRIAGE, bring back into working position 1 st. 2x ON EACH SIDE, then 2 sts. 1x ON EACH SIDE.
Change to a contrast color and knit 2 rows.
Change to color 1 and REPEAT FROM * till there are 5 sections ending with 2 rows contrast.
Remove onto contrast waste yarn.

FINISHING: Weave the open sts. together and remove the waste yarn. With yarn end, make a running stitch at one end and pull up to close hole. Stuff with Polyester Fibre fill, making the ball nice and round. Close other end and leave long end to make a loop. Tie the loop at top at length you want and cut off remaining.

After you have made one or two this way - try changing the colors for each section knitting the 2 contrast colors with same color as section.

STOCKING - Tension 3

Cast on 32 sts. with red.
With tension 3, knit 5 rows.
With tension 3.1, knit 6 rows.
Hang the hem and knit 1 row to the right then change to Tension 3.
Knit 30 rows. Divide in center Put the sts. on the left into holding position and work short rows.
* Put 1 st. opposite carriage into holding position before knitting each row till there are 4 left in center.
Put back 1 st. each side till all are in work.**
Bring all the needles into working position and knit 13 rows over all needles. Carriage on the left.
Put the right side half into holding position and work the short rows over the left side sts. following the instructions from * to **.

Knit 1 row over all sts. then remove onto contrast waste yarn.
When you have made this one using only 1 color - make some more. Make the top hem in a design - make the toe and heel in a contrast color - stripe it using 4 rows color 1, 2 rows color 2...etc.

FINISHING: Sew or weave seam. Trim with sequins or any way your imagination comes up with. Make a loop at top for hanging.

CANDY CANE - Tension 3

With white, 'e' cast on 1 st. knit 1 row.
Increase 1 st. beginning next 4 rows (5 sts.)
Knit 60 rows.
Change to Red and knit 60 rows. Transfer 1 st. each side beginning next 2 rows, bind off 1 st.
Tie white end to red end then hide all ends. Wet then dip into heavy starch. Twist the two colors together tightly and pin to towel forming a cane and allow to dry thoroughly. You can tie a small bow on cane when dry.



continued

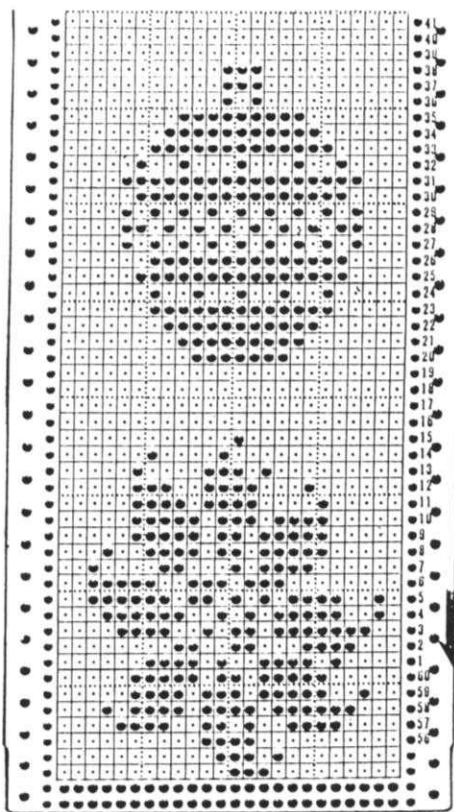

CHRISTMAS POTPOURRI

WREATH - Tension 2 and 3

Hang Cast on comb for cast on comb hem or if you do not have one, begin with waste yarn. Every other needle, cast on 60 sts. with green.

With tension 2, knit 10 rows. Make eyelets over every other needle (Use Lace Carriage) With tension 3, knit 6 rows. With tension 3.2, work the Lace Design but after LAST TRANSFER, knit 6 rows (instead of 2) with tension 3. Make eyelets over every other needle (Use Lace Carriage) With Tension 2, knit 10 rows. Hang hem and remove the sts. onto double strand of yarn.

FINISHING:

Weave the ends together and pull up sts. held on doubled yarn. Make a chain with red or use two strands of yarn (or you can use a very narrow ribbon and thread through eyelets and form bow. Make a loop at top for hanging.

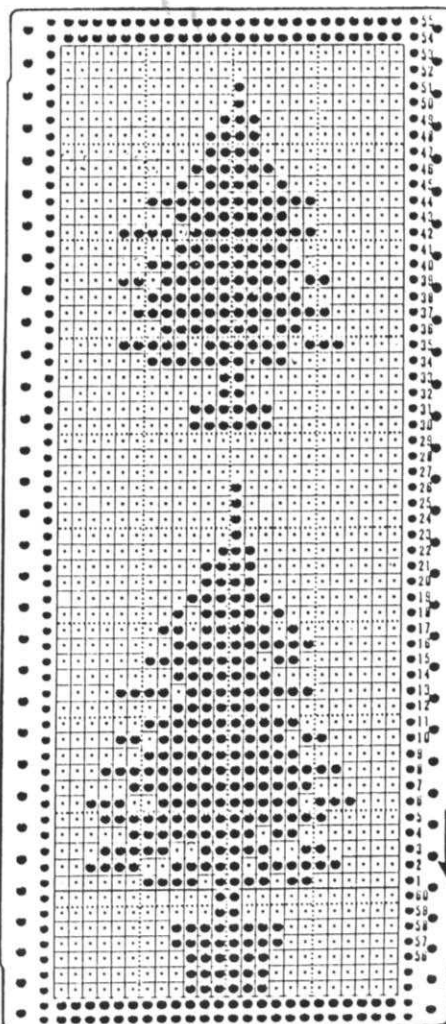

LACE HEM FOR WREATH AND BELL.

Use any small (less than 24 sts.) Christmas Design and make a sample. Try tension 3 to 4. Press the sample and see if it will fit into the frame. If not, you can always cut the design down a bit to fit.

Cast on with a background color such as white. Since you will be cutting the knitting - use an automatic cast on. 34 to 44 sts. Knit about 10 extra rows above the completed design using Stockinette stitch. If you want to make more than one - knit 10 more rows Stockinette stitch and repeat the design. Continue for as many as you want.

Run the Carriage across without yarn after you have knitted the final 10 or 12 rows waste knitting. Press and steam your pictures. Cut them apart between the extra rows stockinette stitch. Take the cardboard and place it on the wrong side of your knitting but BE SURE to center the design. Hold it flat or even pin it to hold, then set your sewing machine to sew 12 sts. to the inch and sew around the cardboard. Be careful not to disturb the design. You can use a straight stitch or even a small zig zag. Cut around the cardboard and knitting. Place the picture in the frame and you are finished.

Eyelet across then with tension 2.1, knit 12 rows. Hang the hem and with tension 3, knit 1 row. Remove the sts. onto double strand of yarn and pull up. Sew or weave seam. Make loop at top and hang small jingle bell inside. Thread double strand of contrast yarn or make chain and pull through eyelets and make bow.

After you have made one this way, be creative and line the inside with a contrast color - make one with a few rows of another color on the outside. Put a small Fair Isle Design in the 12 rows, etc. etc.



BELL - Tension 2.1 and 3

Same cast on as for Wreath. Cast on 40 sts. Tension 2.1. Knit 12 rows. Eyelet across same as for wreath. With tension 3, knit 12 rows. Work the Lace Design but after last transfer, knit 12 rows.

PICTURE FRAMES - ISOLATE THE DESIGN

You can purchase small needle-point frames at any craft or needlework shop. Inside, is a round piece of light weight cardboard which is covered over with a separate plastic disc. Save the cardboard for mounting your picture.

JAR COVERS

The Jar Covers are made in the same way as the Picture Frames but you will have to use the insert disc in Jar and cut your own light weight cardboard. Before sewing around the knitting on cardboard, tuck a small piece of cotton between the knitting and cardboard. Sew or zig-zag around. Finish in the same way as you did for Picture Frames.

WALL HANGING

SIZE: Approximately 15" x 40"
 YARN: Cordella
 AMOUNT:
 color 1 3 balls
 color 2 1 ball - Green) used
 color 3 1 spool Mami Rex) together
 color 4 1 ball Isabella
 TENSION: 7
 GAUGE: 14 sts. 18 rows = 2" (5 cm)

Can be made on any Electronic machine. For full size copy of Design, send \$1.00 plus large No. 10 envelope. You will need a Rod for hanging (see picture).

With contrast waste yarn, cast on 104 sts. Knit 9 to 11 rows knit 1 row with Ravel Cord to the right side. Counter at 0, change to color 1. Work Stockinette stitch. Knit 4 rows. Lace Pattern -*Lace Carriage 10x, knit 2 rows. REPEAT FROM * 4 times MORE. After Row 14, hang the hem by picking up the first row above Ravel Cord. Continue in Stockinette stitch with color 1. After Row 44, work PATTERN 1 (see Chart).

After Row 193 work as follows:
 Before knitting the last row (194) Pattern Sheet will return to first row of pattern. Knit this last row (194) then push the selected needles back to B position.
 Release KC and MC (to release Pattern setting) Push in Part buttons (for FREE PASS) and move Carriage to the left side. Return to SET LINE.
 Program Pattern 2, Set KC (to select needles) and move Carriage to the RIGHT.
 Turn Row Counter back to 194. Push in MC button and CONTINUE in Pattern 2.
 After Row 327 - Set Pattern 3 same as above.
 When Pattern 3 is completed, continue in Stockinette stitch with color 1.
 MARK ROW 373. After Row 394, pick up the stitches from marked row to form hem. Knit 1 loose row then bind off.

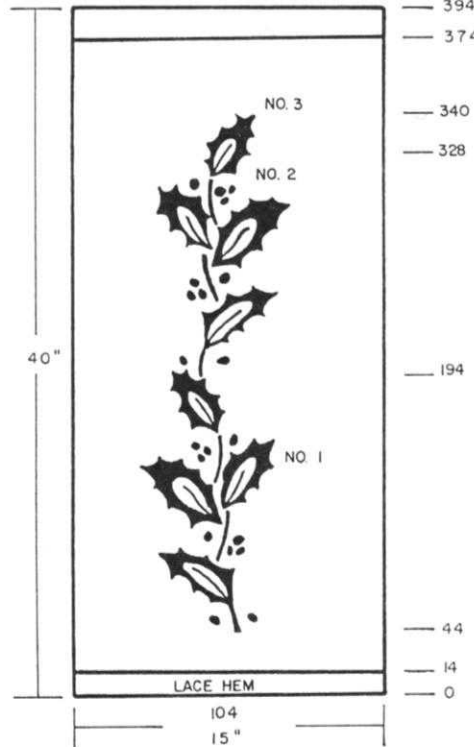

CORD:

Set your machine for knitting a cord over 5 needles using color 1. Make cord approximately 80" long. Bind off.

FINISHING: Steam carefully into shape. With ISABELLA, embroider over the berries (See Picture). If you like, you can knit a lining to fit using color 1 then sew together with right sides facing, leaving 1 end open. Turn and press. Or if you prefer mount the hanging on cardboard. Cut knitted cord in half and attach one cord at each end of hanging. Attach other cord as shown in picture. Run rod through hem at top.

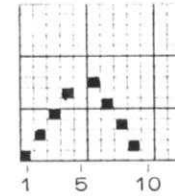

SCALLOPED LACE HEM

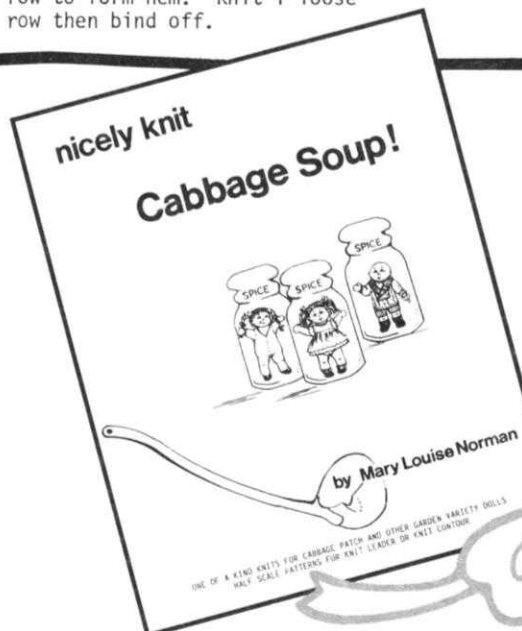
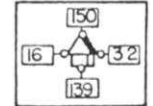
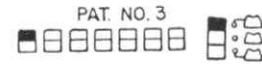
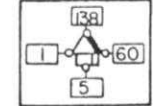
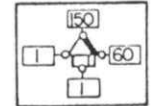
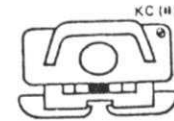
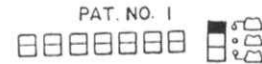
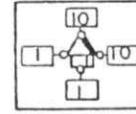

Nicely Knit Lines

There's another excellent book from the pen of Mary Louise Norman. Dedicated to "The knitters of the world who love dolls," it contains 33 garment patterns for Cabbage Patch and other Dolls plus a lot of Practical Knitting Hints...

Price \$15.50 (Calif. residents add Sales Tax) plus \$1.50 mailing costs.

Order direct from KNITKING-1128 Crenshaw Blvd., Los Angeles, CA 90019

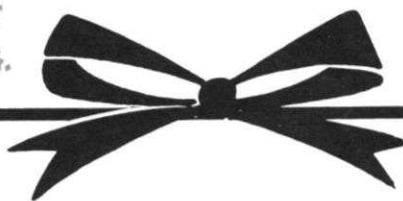

PRACTICAL KNITTING HINTS - VOLUME 20 No. 1

SPECIAL RIBBING

Some of the garments in this issue of KNITKING MAGAZINE have a SPECIAL RIB SETTING for BANDS. Two examples are 402 and 403. This is a FULL NEEDLE Ribbing using every needle on the main machine and every needle on the Ribber. Some of you have the KR 830 Ribber and some have the newer KR 900 Ribber. The 900 Ribber has CHANGE KNOBS, one on the left and one on the right but the KR 830 does not have these knobs. Without the Change Knobs, you must knit these special bands in a different manner. Do try a sample first using the instructions given for the different Ribbers.

IF YOU OWN A KR 900 RIBBER

Counter at 0 and Tension as specified. Cast on the required number of sts. with the Zig-zag cast on from right to left. Set Ribber - LEFT PR DOWN, RIGHT PR UP. Knit the 3 selvedge rows - Carriage now on the right side. (Row Counter at 4).

Put the SLIDE LEVER at I or II (depending on pattern instructions)

LEFT and RIGHT CHANGE KNOBS turned to the OUTSIDE. MAIN MACHINE - PUSH IN THE LEFT PART BUTTON. (Leave controls on both beds as set throughout). CHANGE TENSION ON BOTH BEDS as given in Garment Instructions. Knit the ribbing for the required number of rows then transfer the ribber sts. to main machine. There are now 2 sts. on each needle. Bring all needles to holding position and change tension to garment tension and knit across all needles. The reason we bring the needles to holding position is to make certain they will knit off when you knit across this first row. Continue as per the instructions.

IF YOU OWN A KR 830 RIBBER

Do read the instructions for the KR 900 Ribber FIRST. Follow the same instructions with the exception of the CHANGE KNOBS information (you do NOT have them) and after you change the tension on BOTH BEDS as given in garment instructions (leave Controls on both beds as set), knit to the LEFT. EVERY TIME the Carriage is on the LEFT SIDE, you must take the every other needle selector and begin with the 2nd Ribber needle on the LEFT, push EVERY 2nd NEEDLE UP TO 'D' POSITION. Knit to the right side. This is what happens - the Ribber needles in 'D' position WILL KNIT but the needles in B position WILL NOT KNIT because the right PR is UP. When you knit back to the left side, remember to ALWAYS PUSH THE SAME RIBBER NEEDLES TO 'D' position. It is easy to remember to begin with the 2nd needle on the left.

If you own a different Ribber other than the KR 900 or KR 830 you can follow the instructions for the KR 830 but set your Ribber Controls to SLIP as you knit from left to right and when Carriage is on the LEFT SIDE, push every 2nd needle to SELECTING position....

HINT... HINT...

Whenever you have 2 or more sts. on one needle - for instance if you are doubling up sts. and putting them onto needles or when you are hanging a neck edge onto a neckband, it is a good idea to bring the needles into HOLDING (E) position before knitting across so that all the stitches will knit off together.

YARN KITS FOR GARMENTS IN THIS ISSUE

Most of the garments in this issue of KNITKING MAGAZINE were knitted with yarn from our YARN CATALOGUE which illustrates the full range of colors available and includes actual samples. If you do not have our Catalogue, please send \$3.00 and we will mail you one immediately. You will then be able to choose your own colors.

VENETIA, our best selling yarn is not shown in the above Catalogue but we now have a Sample Card showing all the colors available. The same colors shown on the card are available in our Bulky Venetia as well. Please send \$1.00 and we will mail you a Sample Card.

ROMA - We now have a Sample Card for ROMA, a lovely synthetic yarn and if you would like to have a card with all the colors available, send \$1.00 and we will mail one to you.



ANGORA - We now have some fantastic 100% pure French Angora at \$5.50 per 10 gr. ball. The colors available are: White, Pink, Champagne, Coral, Scarlet, Royal Blue, Canary Yellow, Acqua, Lavender, Orchidee, Oatmeal, Pearl Grey, Plum, Purple, Powder Blue, Black.

ISABELLA - This is a metallic glitter yarn in 1 oz. balls. It comes from Brazil and is available in packages of 10 balls for \$10.00. The regular price is \$5.50 per ball so the cost to you of \$1.00 per ball is a great bargain. You must purchase a full package of 10 in one color. Great for all your holiday knitting. The colors are: Red, Copper, White, Royal Blue, Green, Silver, Gold, Green & Gold mixed, Blue & Gold, Black & Gold, Acqua & Gold.

No. 481 - Yarn:	Regia		
SIZES:	4/6	(8/10)	[12/14]
Price:	\$13.20	\$15.40	\$15.40
Shipping:	1.85	1.85	1.85

No. 482 - Yarn:	Show		
SIZES:	4/6	(8/10)	[12/14]
Price:	\$26.95	\$29.40	\$31.85
Shipping:	2.20	2.20	2.20

No. 483 - Yarn:	Alpacana		
SIZES:	10/12	(14/16)	
Price:	\$31.20	\$31.20	
Shipping:	1.85	1.35	

No. 484 - Yarn:	Venetia, Mami Rex (Rainbow) and Angora		
SIZES:	12/14		
Price:	\$107.84		
Shipping:	3.50		

No. 485 - Yarn:	Roma		
SIZES:	8/10	(12/14)	[16]
Price:	\$10.35	\$10.35	\$11.73
Shipping:	1.85	1.85	1.85

No. 486 - Yarn:	Venetia		
SIZES:	6/8	(10/12)	[14/16]
Price:	\$31.68	\$31.68	\$31.68
Shipping:	2.20	2.20	2.20

If you want a full size copy of the Design to put on your mylar sheet, send \$1.00 plus a self addressed, stamped No. 9 envelope.

No. 487 - Yarn:	Venetia & Angora		
SIZES:	8/10	(12/14)	
Price:	\$42.68	\$42.68	
Shipping:	2.20	2.20	

No. 488 - Yarn:	Venetia, Mami Rex & Angora		
SIZES:	8/10	(12/14)	
Price:	\$142.18	\$142.18	
Shipping:	4.50	4.50	

No. 489 - Yarn:	Amore		
SIZES:	6/8	(10/12)	[14/16]
Price:	\$19.12	\$19.12	\$21.51
Shipping:	1.85	1.85	1.85

If you want a full size copy of the Design to put on your mylar sheet, send \$1.00 plus a self addressed, stamped No. 9 envelope.

No. 490 - Yarn:	Venetia		
SIZES:	8/10	(12/14)	[16]
Price:	\$28.71	\$36.63	\$36.63
Shipping:	2.20	2.20	2.20

No. 491 - Yarn:	Amore		
SIZES:	Small	(Medium)	[Large]
Price:	\$21.50	\$23.90	\$26.29
Shipping:	1.85	1.85	1.85

If you want a full size copy of the Design to put on your mylar sheet, send \$1.00 plus a self addressed, stamped No. 9 envelope.

No. 492 - Yarn:	Venetia		
SIZES:	6/8	(10/12)	[14/16]
Price:	\$85.39	\$85.39	\$85.39
Shipping:	3.50	3.50	3.50

If you want a full size copy of the Design to put on your mylar sheet, send \$1.00 plus a self addressed stamped No. 9 envelope.

No. 493 Yarn: Venetia & Angora
 SIZES: 8/10 (12/14)
 Price: \$41.26 \$41.26
 Shipping: 2.20 2.20

No. 494 - Yarn: Venetia & Mami Rex
 SIZES: 8/10 (12/14)
 Price: \$71.93 \$71.93
 Shipping: 2.50 2.50

If you want a full size copy of the Design to put on your mylar sheet, send \$1.00 plus a self addressed, stamped No. 9 envelope.

No. 495 - Yarn: Venetia
 SIZES: 6/8 (10/12)
 Price: \$23.76 \$23.96
 Shipping: 2.20 2.20

No. 496 Yarn: Venetia
 SIZES: 38/40 (42/44) [46]
 Price: \$15.84 \$15.84 \$19.80
 Shipping: 1.85 1.85 1.85

No. 497 - Yarn: Beatrice
 SIZES: 40/42 (44/46)
 Price: \$28.50 \$31.35
 Shipping: 1.85 1.85

No. 498 Yarn: Alanda
 SIZES: 22" to 24" Bear
 Price: \$6.40
 Shipping: 1.85

No. 499 Yarn: Daisy
 SIZES: 6/12 months (12/16 months)
 Price: \$4.80 \$6.40
 Shipping: 1.85 \$1.85

No. 500 Yarn: Daisy
 SIZES: 9/16 months
 Price: \$8.00
 Shipping: 1.85

WALL HANGING: Yarn: Cordella
 Price: \$13.71
 Shipping: 2.20

If you want a full size copy of the Design to put on your mylar sheet, send \$1.00 plus a self addressed stamped No. 9 envelope.

There are no instructions for the large Christmas Stocking shown with No. 481. It was given to us. However, if you want to design and knit one, the Punch Cards are available from the Knittery, Box 616, Walker, MN 56484.

The Christmas ornaments use very small amounts of yarn and we did not list them as kits. You can use yarns left over from other projects. We used ISABELLA glitter yarn for the designs and you can order a box of 10 balls in mixed colors for \$10.00 plus shipping costs of \$1.85.



NEW, DEMONSTRATORS AND TRADED MACHINES AT GIVE AWAY PRICES...

Nobody can beat our prices, so if you want a second machine, place your order as fast as possible... Maybe you have a friend who cannot afford a brand new machine... If so, please tell her about our low, low prices... and if you want a machine not listed below, let us know... We have too may to list them all.

ALL PRICES F.O.B. LOS ANGELES - SHIPMENT VIA UPS

		CONDITION	LIST PRICE	SALE PRICE
KH 910	COMPUKNIT ELECTRONIC W/Lacemaker OK for use with KG 88 Garter Carriage (Demo - New Machine Guarantee)	Like New	\$949.95	\$699.00
KH 910	COMPUKNIT ELECTRONIC W/Lacemaker and Ribber (Demo - New Machine Guar.)	Like New	\$1249.90	\$849.00
KH 891	Punch Card Knitter W/built in Knitleader and Lacemaker. OK for use with KG 89 Garter Carriage (Demo - New Machine Guar.)	Like New	\$599.95	\$499.00
KH 891	Punch Card Knitter withbuilt in Knitleader Lacemaker, and Ribber. (Demo - New Machine Guarantee)	Like New	\$899.90	\$649.00
KH 881	Punch Card Knitter W/built in Knitleader and Lacemaker	Excellent	\$549.95	\$399.00
KH 881	Punch Card Knitter W/Lacemaker and Ribber	Excellent	\$849.90	\$549.00
KH 840	Punch Card Knitter W/Lacemaker	Excellent	\$499.95	\$299.00
KH 830	Punch Card Knitter W/Lacemaker	Excellent	\$449.95	\$249.00
KH 820	Punch Card Knitter W/Lacemaker	Very Good	\$399.95	\$199.00
KH 120	Fine Needle Knitter W/258 needles and Lacemaker, Push Button Pattern Selection (Demo - New Machine Guarantee)	Like New	\$399.95	\$249.00
KH 260	New Model Bulky Punch Card Knitter (Demo - New Machine Guarantee)	Like New	\$579.95	\$475.00
KH 230	Bulky - (Demo)	Like New	\$379.95	\$249.00
KH 230	Bulky - With Ribber	Excellent	\$679.90	\$350.00
KH 230	Bulky Ribber	Excellent	\$299.95	\$150.00
KH 710	GENIE Push Button Pattern Selection W/Lacemaker (Demo - New Machine Guar.)	Like New	\$289.50	\$199.00
KH 710	GENIE Push Button Pattern Selection W/Lacemaker and Ribber (New Machine Guar.)	Like New	\$559.00	\$375.00
S 120	JUMBO GENIE with built in Intarsia (Demo - New Machine Guarantee)	Like New	\$199.95	\$175.00
R 120	JUMBO GENIE Ribber (Also fits S140)	Excellent	\$199.95	\$175.00
KG 88	Garter Carriage for KH 910, KH 881 (Demo - New Machine Guarantee)	Like New	\$299.95	\$249.00
KG 89	Garter Carriage for KH 891 (Demo - New Machine Guarantee)	Like New	\$289.95	\$249.00



Essentials...

Order from your local Dealer or direct from
KNITKING—1128 Crenshaw Blvd.,
Los Angeles, California 90019

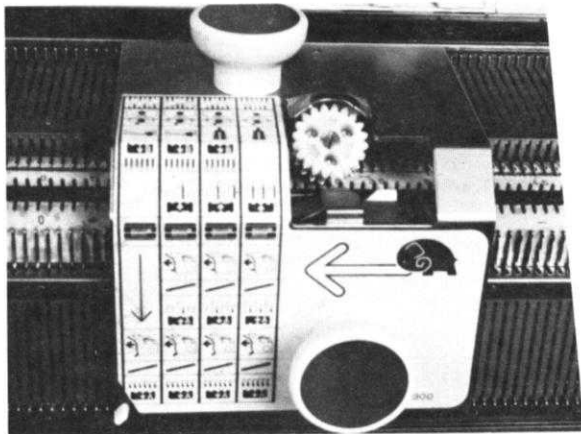

For fast and accurate transfer of stitches from Ribber to Knitter, the Automatic Transfer Carriage is ESSENTIAL.

Model 8300 is for Ribbers KR 900, KR 880, KR 850 and KR 830 and machine Models KR 830 through KH 910.

The PM 10 Automatic Punch Card puncher is essential for speedy punching of all your punch card designs. It's O.K. for all KNITKING, Singer, Studio and Toyota punch card machines except the Singer/Studio F-370 machine which uses the PM 70 Automatic Puncher.

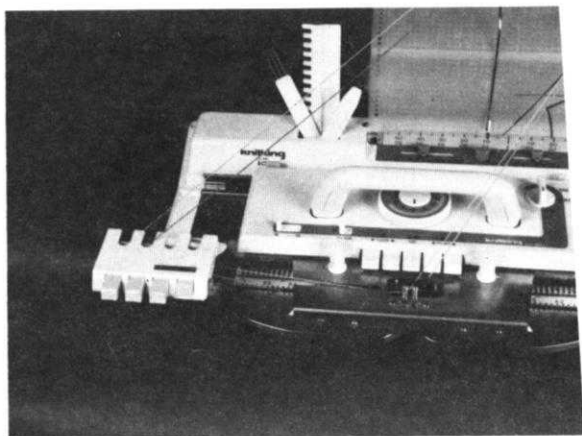
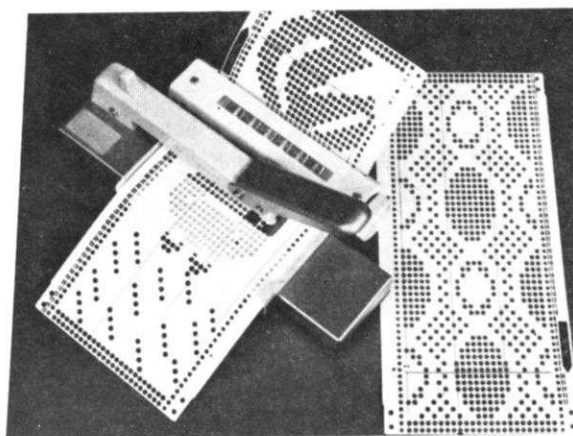

The KHC 820 Color Changer is essential for automatic changing of colors when knitting on KNITKING machine Models KH 820 through KH 910.

The KRC 830 Color Changer is essential for automatic color changing and the knitting of four color designs when using a Knitter and Ribber combination. It operates on Models KH 820 through KH 910 with Ribbing Attachment.

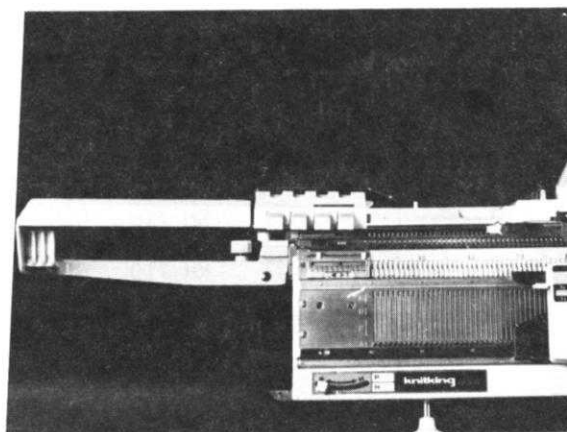

490

Dramatic

A gorgeous two-piece Dress you'll never be able to resist...easier than it looks to knit, the top is Stockinette stitch knitted sideways on the machine with bands of lace peeping through pleats on the front section. The lace bands are repeated on the sleeves. The Skirt is Stockinette stitch in two sections. Knit it with Venetia in Sizes 8 to 16.



496

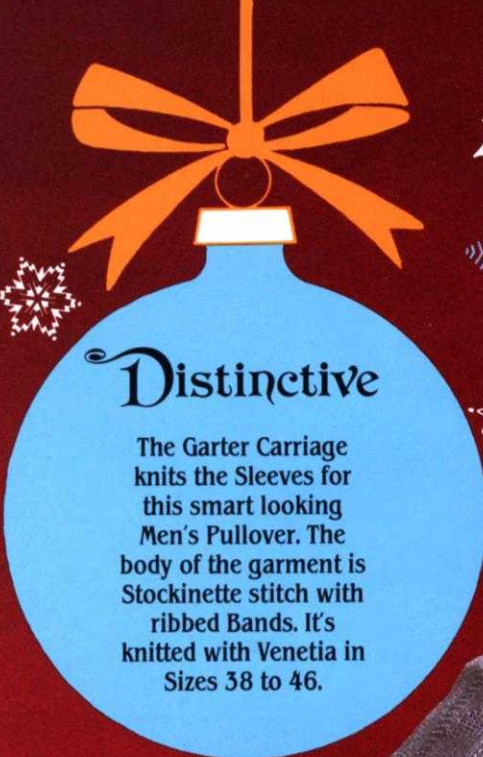

Distinctive

The Garter Carriage knits the Sleeves for this smart looking Men's Pullover. The body of the garment is Stockinette stitch with ribbed Bands. It's knitted with Venetia in Sizes 38 to 46.

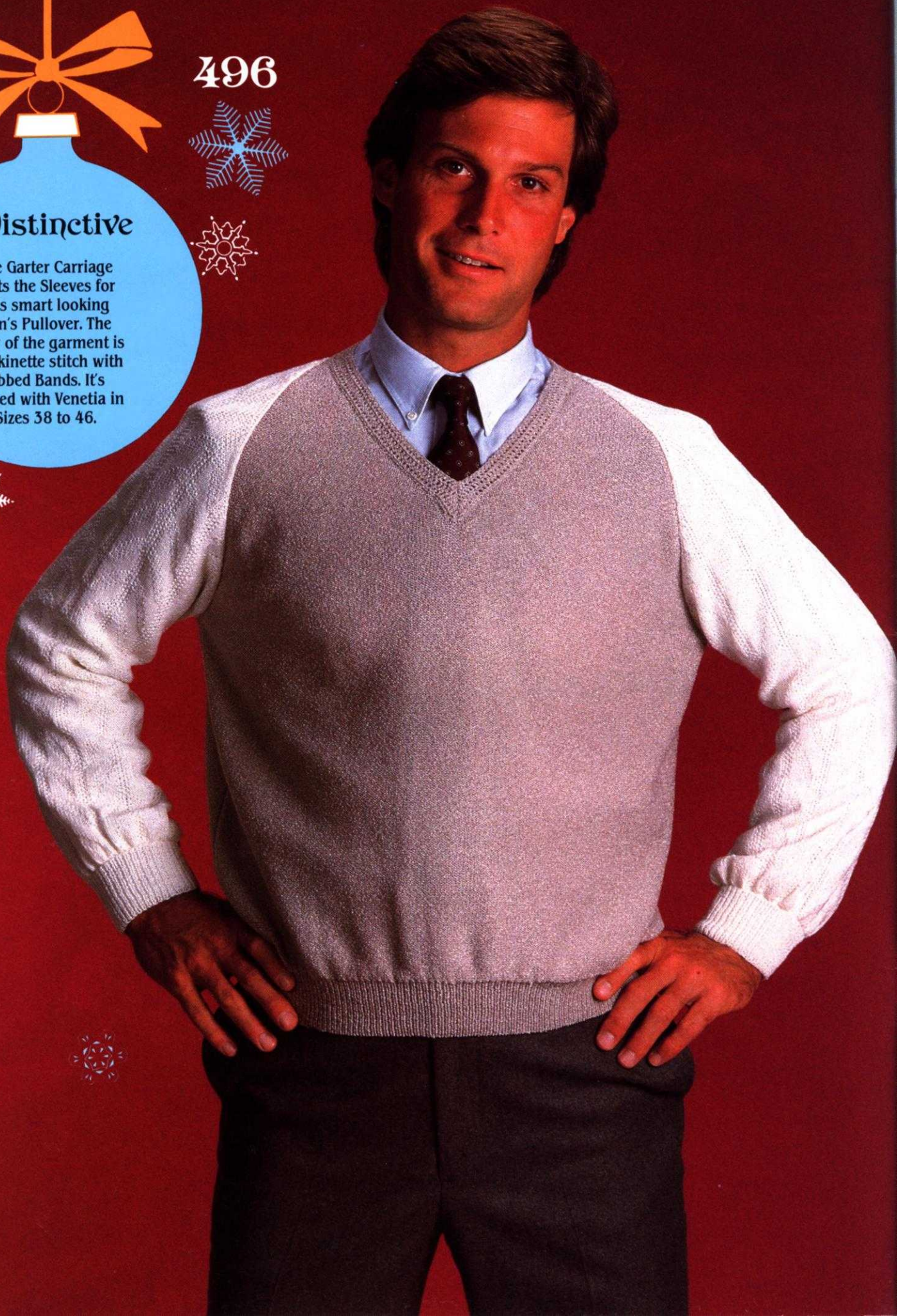

KNITKING KH 891 WITH KG 89 ELECTRIC CARRIAGE

Feed in a pattern stitch card. Set the row counter to a specific number of rows, then push the start button and you can leave to watch T.V. or cook the dinner, read a book, etc., while your knitter knits merrily along. When it has knitted the preset number of rows, it will switch itself off. If it runs out of yarn, it will switch itself off. The KG 89 Electric Carriage will knit an unlimited variety of fancy Garter Stitch designs in addition to standard ribs.

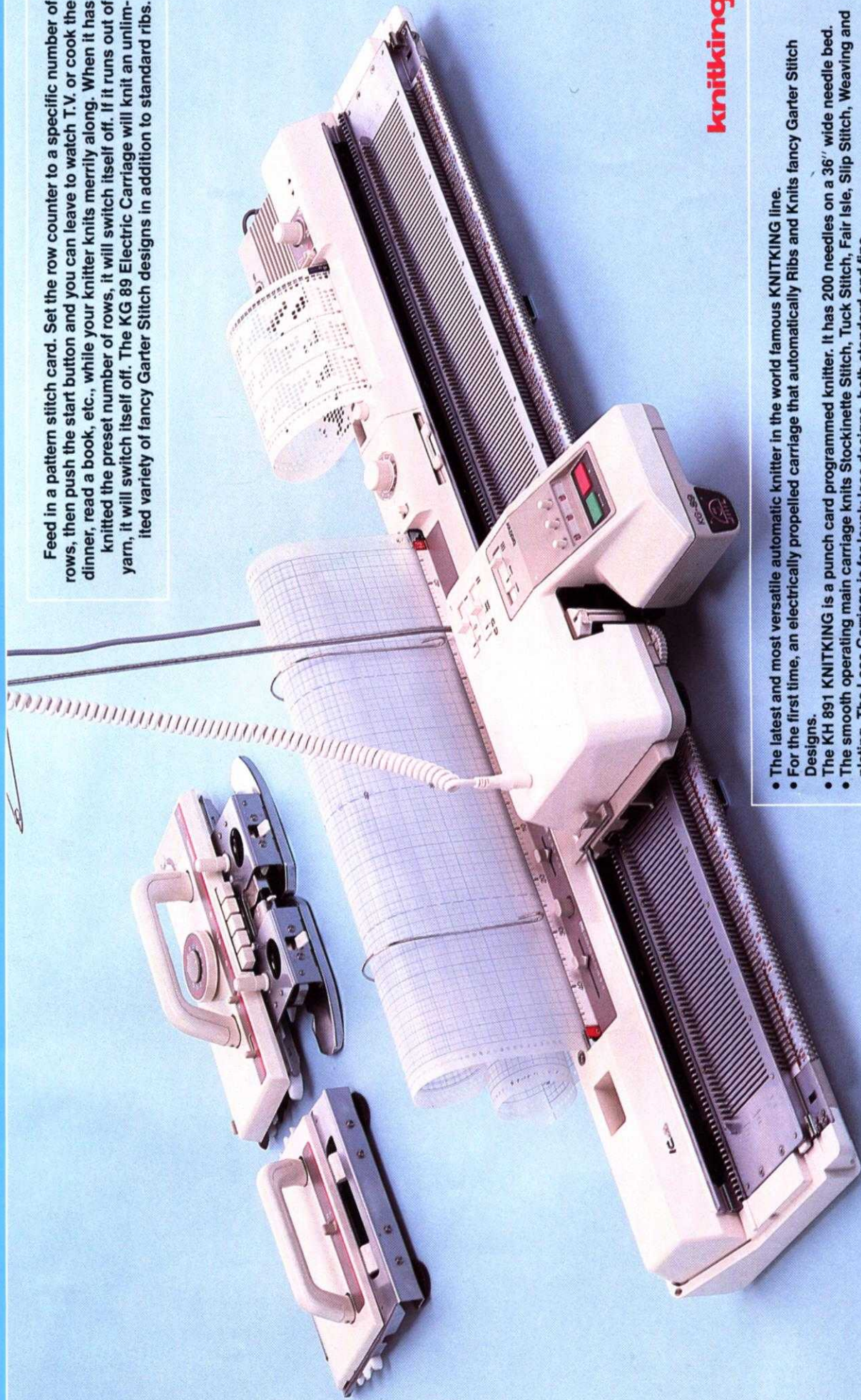

knitking

- The latest and most versatile automatic knitter in the world famous KNITKING line.
- For the first time, an electrically propelled carriage that automatically Knits fancy Garter Stitch Designs.
- The KH 891 KNITKING is a punch card programmed knitter. It has 200 needles on a 36" wide needle bed.
- The smooth operating main carriage knits Stockinette Stitch, Tuck Stitch, Fair Isle, Slip Stitch, Weaving and plating. The Lace Carriage is for lovely lace designs, both standard and fine.
- 20 Pre-Punched Pattern Cards for all types of pattern knitting are included with every machine. The built-in Knitleader Charting accessory tells you on a row by row basis when to increase and when to decrease. Simplifies the knitting of garments to accurate size.
- A complete kit of Tools, spare needles, cabling tools, lubricating oil and two, step by step Instruction Manuals with over 400 illustrations are included and there is a one year warranty on parts and service.

Order from your local dealer or direct from **KNITKING—1128 Crenshaw Blvd. Los Angeles, CA 90019**



499

Adorable

Jennifer wears her pretty Cardigan with ruffled Collar and shoulder trim. Isolated Lace is on the front section with multi-colored flowers embroidered in center of each diamond. She loves the Christmas Ornaments (instructions in this issue). Sizes are 6 to 16 months, the yarn Daisy.



500



Holiday Special

For any child, a geometric Design Cardigan in any becoming colors will be a welcome gift. It's easy and fun to knit using Short Rows. Knit it with Daisy in Sizes 9 to 16 months.



COMPUKNIT KH 910

'The world's finest knitting machine'

- Incredibly versatile... Anything you can trace or draw is automatically reproduced in your knitting in the colors and yarns of your choice.
- Simple to program and easy to operate, the COMPUKNIT KH 910 is the 'State of the Art' in home knitting machines. It is the only knitter made that has a memory unit to retain your program if you suffer a power outage or wish to move your knitter from one place to another.
- The maximum width of motif or pattern design possible on any punch card machine is 30 stitches (the standard is 24). The COMPUKNIT has no limit. It is possible to knit a single picture or lace design over the full width (200) needles of the needle bed. It will, in fact, do everything that's possible on a punch card machine and much much more.
- If you already own a knitting machine, you must consider trading up to a fantastic COMPUKNIT 910. If you have never owned a knitter before, start at the top and save money and save all the intermediate steps.



Order from your local Dealer or direct from
VISA and MASTERCARD accepted

KNITTING

1128 Crenshaw Blvd.
Los Angeles, CA 90019
Telephone: (213) 938-2077

491



Universal

Snow time means Ski time and you can flash your winter sport interest wearing this great Pullover with isolated skiers. In Sizes Small, Medium and Large to fit anyone. You have the choice of a Neckband or a turtle neck Collar. Amore is the yarn.



485

Intarsia Inspiration

More popular than ever before, Intarsia Designs fill the desire for splashes of color in hand and machine knits. You will have fun knitting this Pullover with color stripes combined with a simple Design. Roma is the yarn. Sizes 6 to 16.

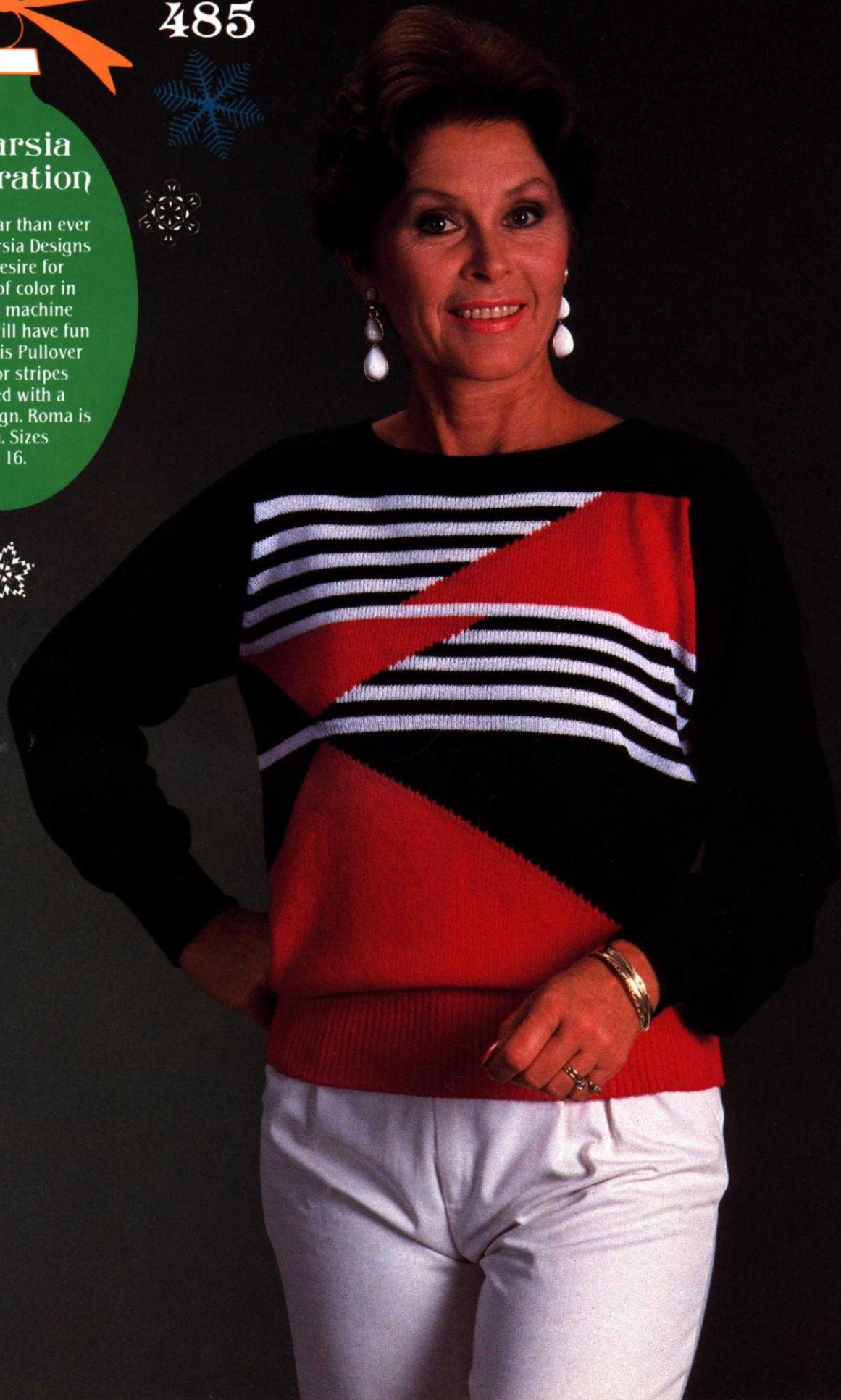

483



Teen
Preference

Great patterning for a teen's Pullover. Three Fair Isle Designs make this super warm and interesting...Knit it with Alpacana on any standard Punch Card machine. Sizes 10 to 16.



Genie
 "the magic knitter"

KH 710

It's the lowest priced automatic 200 needle knitter with Lace Carriage (it knits fine lace as well as regular lace) on the market today. It has Push Button Pattern Selection and twin yarn feeder for unlimited fancy stitches plus built in Weaving Wheels for automatically weaving yarns of different weights and textures into cushion covers, bedspreads, wall hangings, etc.

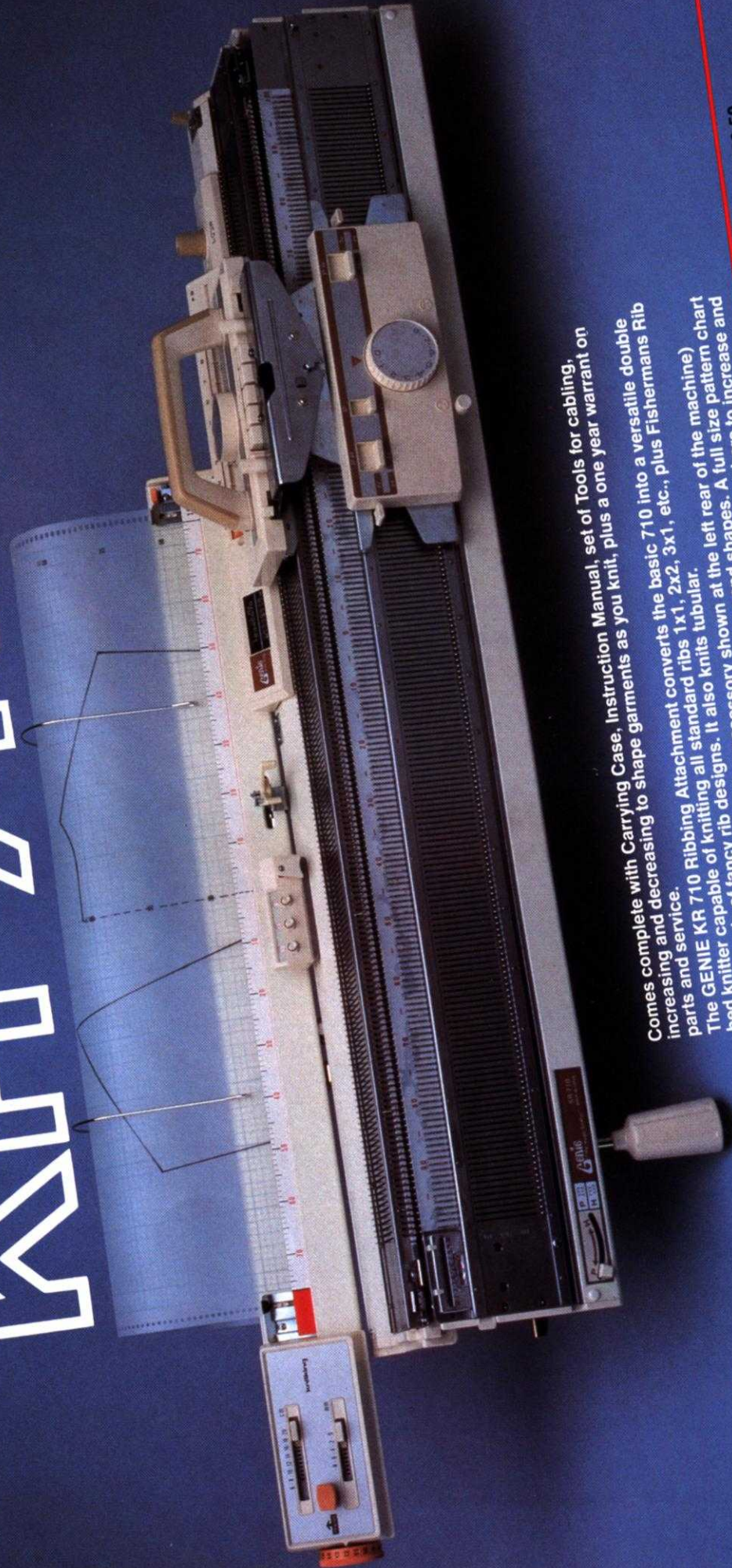

Comes complete with Carrying Case, Instruction Manual, set of Tools for cabling, increasing and decreasing to shape garments as you knit, plus a one year warrant on parts and service.

The GENIE KR 710 Ribbing Attachment converts the basic 710 into a versatile double bed knitter capable of knitting all standard ribs 1x1, 2x2, 3x1, etc., plus Fishermans Rib and hundreds of fancy rib designs. It also knits tubular.

The 116 Knitleader (the charting accessory shown at the left rear of the machine) simplifies the knitting of garments to correct sizes and shapes. A full size pattern chart rotates as you knit and shows you on a row by row basis exactly where to increase and decrease.

.....	\$289.50
.....	269.50
.....	109.95
TOTAL	\$668.95
.....	\$499.00
.....	\$570.00

You can order from your local dealer or direct from
 KNITTING 1128 Crenshaw Blvd.,
 Los Angeles, CA 90019
 (213) 938-2097

The everyday low price of the GENIE KH 710 is
 The price of the KR 710 Ribber is
 The price of the 116 Knitleader is
 Order the KH 710 and the 710 Ribber for
 Order all three pieces for



484



Luxurious

A Bulky machine is used to knit this Basket Weave Beauty. It takes a bit of concentration but if you make a sample of the three levels first, you'll sail through the knitting easily. Try it...Use our Venetia with super soft Angora. Sizes 12/14.

KNITKING Punch Card Programmed Bulky

The very latest and easily the most versatile of all Bulky knitting machines. It's the first with automatic PUNCH CARD PATTERN selection and it knits a range of yarns from sport weight to jumbo, including Angora, Mohair, Boucle, Ribbon, Cotton, Acrylic, etc. The KNITKING KH 260 has 114 stainless steel needles in a needle bed 40" wide. At 3 stitches per inch, it knits up to 38" wide. The Tension Control Dial has 30 tensions for knitting different weights of yarn... Comes complete with TWIN OVERHEAD FEEDERS, 15 PRE-PUNCHED PATTERN CARDS, ROW COUNTER, complete TOOL KIT, STITCH MEASURE SCALES for Knitleader, CARRYING CASE, a detailed, well illustrated, easy to understand INSTRUCTION MANUAL and a one year warranty on parts and service.

Accepts standard 24 stitch Punch Cards for:

- Fair Isle Patterns
- Weaving
- Skip Stitch and Tuck Stitch
- Automatic Plating
- Thread Lace
- Isolation Motifs

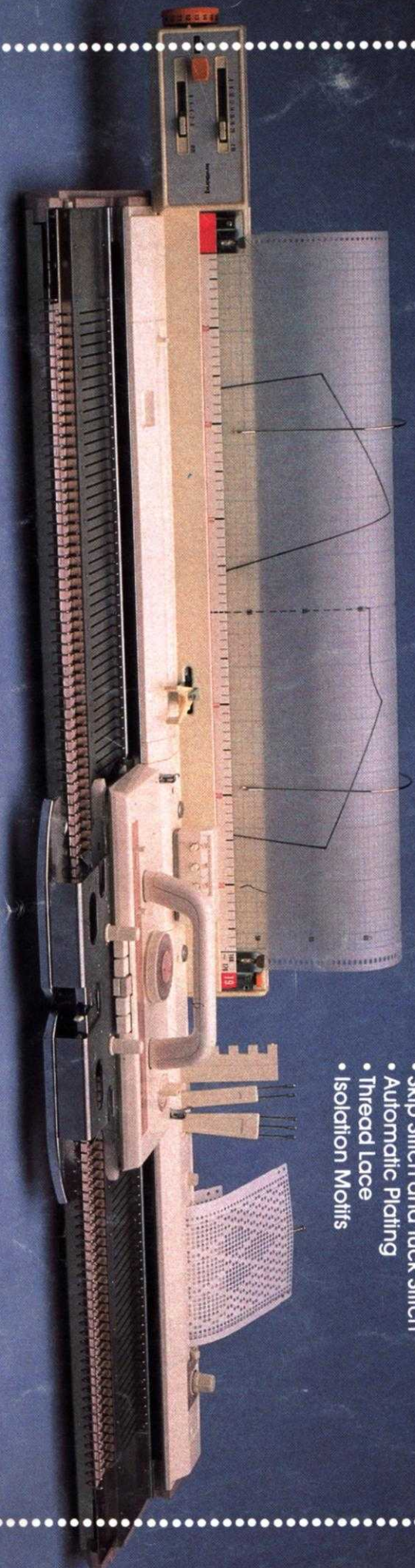

Model KH 260

Order from your local Dealer or direct from:
KNITKING CORPORATION — 1128 Crenshaw Blvd.,

Los Angeles, CA 90019 Telephone: (213) 938-2077