

# HOW TO USE AND ENJOY YOUR KNITTING MACHINE



# LESSON 1

<b>1. HOW TO USE YOUR KNITTING MACHINE</b>	<b>5</b>
1-1. Setting up your machine .....	5
1-2. Folding up your machine .....	11
<b>2. HERE ARE A FEW IMPORTANT POINTS TO REMEMBER BEFORE YOU START KNITTING</b>	<b>15</b>
2-1. Preparation of yarn .....	15
2-2. Threading the Yarn Tension Unit .....	16
2-3. Needle position .....	18
2-4. Name of parts . . . . K carriage .....	18
2-5. Relation between the Tension Dial and Yarn .....	19
<b>3. BASIC OPERATION PRACTICE I (PLAIN KNITTING)</b>	<b>20</b>
3-1. Plain knitting .....	20
3-2. How to remove the knitting from the machine .....	23
3-3. Cast-on with a finished edge .....	24
3-3-1. Hand method .....	24
3-3-2. Latch tool .....	25
3-3-3. Using the Weaving pattern lever and 1/1 Needle pusher .....	27
<b>4. KNOWLEDGE OF PLAIN KNITTING</b>	<b>28</b>
4-1. When you cannot cast-on well .....	28
4-1-1. When the needles do not catch the yarn .....	28
4-2. When the K carriage is hard to push .....	28
4-3. If the K carriage should jam .....	29

# LESSON 2

<b>5. BASIC OPERATION PRACTICE II (PATTERN KNITTING)</b>	<b>33</b>
5-1. Punch card .....	41
5-2. Relation between the Punch card and the Needles .....	42
5-3. Preparation for pattern knitting .....	43
5-3-1. Setting the Punch card .....	43
5-3-2. Preparation for pattern knitting .....	44
5-4. Tuck stitch patterns. Skip stitch patterns .....	45
5-5. After finishing pattern knitting .....	46
5-6. Two color Tuck stitch patterns. Two color Skip stitch patterns .....	47
5-7. Fair-isle patterns .....	49
5-8. Fair-isle motif .....	50
5-9. Double Fair-isle motif .....	53
5-10. Weaving patterns .....	54
5-11. Double length patterns .....	56
5-11-1. Preparation for Double length patterns .....	57
5-11-2. When knitting Normal and Double length patterns mixed .....	58
5-12. Plating yarn knitting .....	58
5-13. Intarsia knitting .....	60
5-14. How to design your own cards .....	62
<b>6. KNOWLEDGE OF PATTERN KNITTING</b>	<b>64</b>
6-1. If you make mistakes in pattern knitting using the Punch cards How to correct them .....	64
6-1-1. If the K carriage should jam .....	64
6-2. If you make mistakes on knitting Double length patterns How to correct them .....	68
<b>7. BASIC OPERATION PRACTICE III (LACE PATTERN KNITTING)</b>	<b>69</b>
7-1. Lace pattern knitting .....	69
7-2. How to set the L carriage .....	69
7-3. Lace pattern knitting. Fine-lace pattern knitting .....	70
7-4. When knitting Lace and Fine-lace pattern mixed .....	72
<b>8. KNOWLEDGE OF LACE PATTERN KNITTING</b>	<b>73</b>
8-1. If the L carriage should jam .....	73
8-2. Unravelling the knitting .....	75

# LESSON 3

<b>9. MAKING A GARMENT</b>	<b>76</b>
<b>9-1. HOW TO USE THE TRANSFER TOOL AND THE LATCH TOOL.....</b>	<b>76</b>
9-1-1. Transfer tool .....	76
9-1-2. Latch tool .....	77
<b>9-2. INCREASING AND DECREASING STITCHES PICKING UP DROPPED STITCHES</b>	<b>78</b>
9-2-1. Increasing stitches .....	78
9-2-1-1. Increasing one stitch at either edge of the knitting. Simple method .....	78
9-2-1-2. Increasing one stitch at either edge of the knitting. Full fashioned method .....	78
9-2-1-3. Increasing several stitches at either edge of the knitting .....	78
9-2-2. Decreasing stitches .....	79
9-2-2-1. Decreasing one stitch at either edge of the knitting. Simple method .....	79
9-2-2-2. Decreasing one stitch at either edge of the knitting. Full fashioned method .....	80
9-2-2-3. Decreasing several stitches at either edge of the knitting .....	80
9-2-3. Picking up dropped stitches .....	81
9-2-3-1. Repairing a dropped stitch .....	81
9-2-3-2. Repairing a stitch that has dropped several rows .....	82
<b>9-3. HOW TO MAKE A HEM</b>	<b>83</b>
9-3-1. Plain hem .....	83
9-3-2. Picot hem .....	85
9-3-3. 1 x 1 Elastic hem .....	87
<b>9-4. BINDING OFF AND BUTTON HOLE</b>	<b>88</b>
9-4-1. Binding off using the tapestry needle .....	88
9-4-1-1. When the yarn is on the left side .....	88
9-4-1-2. When the yarn is on the right side .....	89
9-4-2. Cast-off using the latch tool .....	90
9-4-3. Vertical seaming of plain stitch .....	91
9-4-4. How to make a button hole .....	92

<b>9-5. HOW TO SHAPE A ROUND NECK LINE</b>	<b>93</b>
9-5-1. Using the holding cam lever .....	93
9-5-1-1. Plain knitting .....	93
9-5-1-2. Pattern knitting .....	94
9-5-2. Using the cast-on thread .....	96
9-5-2-1. Plain knitting .....	96
9-5-2-2. Pattern knitting .....	97
<b>9-6. SEWING PROCEDURE</b>	<b>98</b>
9-6-1. Baste the knitting with binding wire and/or basting thread .....	98
9-6-2. Sewing procedure .....	98
<b>9-7. CLEANING AND MAINTENANCE</b>	<b>99</b>
9-7-1. Replacing a needle .....	99
9-7-2. Cleaning and maintenance .....	100
<b>10. USEFUL HINTS</b>	<b>101</b>
<b>10-1. PARTIAL KNITTING (PLAIN KNITTING &amp; PATTERN KNITTING) .....</b>	<b>101</b>
10-1-1. Decreasing stitches .....	101
10-1-2. Increasing stitches .....	102
<b>10-2. PARTIAL KNITTING (LACE PATTERN KNITTING) .....</b>	<b>103</b>
10-2-1. Decreasing stitches .....	103
10-2-2. Increasing stitches .....	104

# LESSON 1

## 1. HOW TO USE YOUR KNITTING MACHINE

### 1-1 SETTING UP YOUR MACHINE



1. Place the machine on a firm table, with the CARRYING CASE HANDLE away from you.

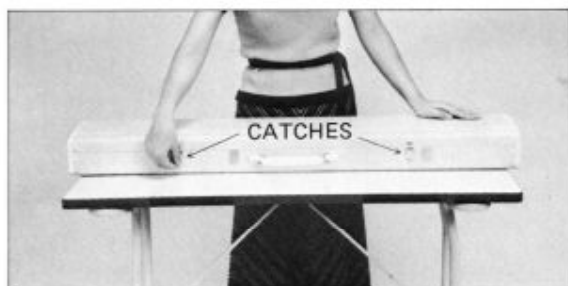

2. Unlock the CATCHES on either side of the handle.

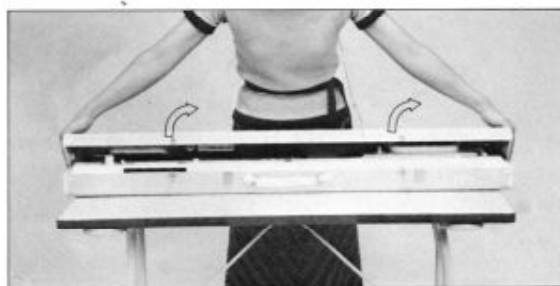

3. Lift the UPPER CASE slightly, and pull toward you to release the lid.

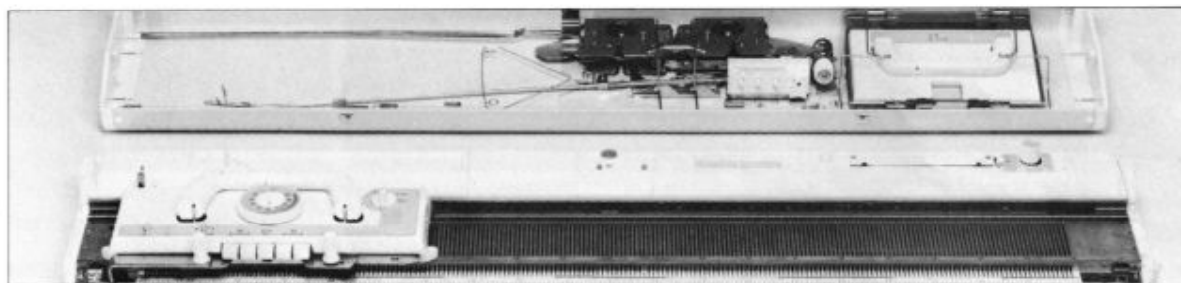

4. After releasing the lid.



5. Take the two TABLE CLAMPS out of the accessory box.

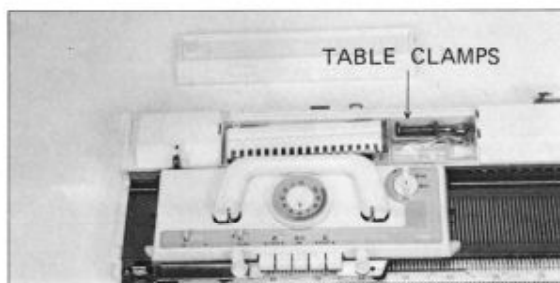

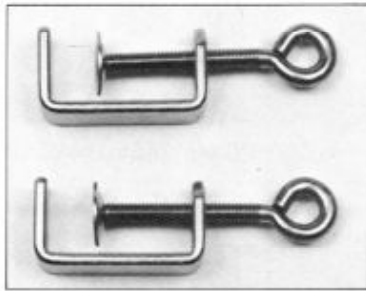
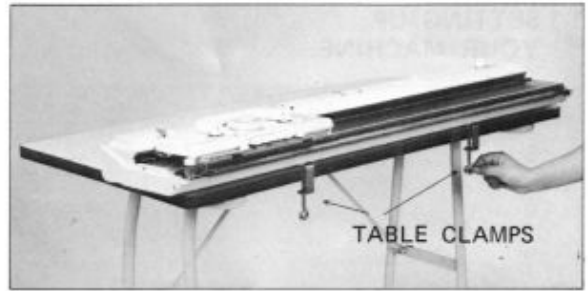
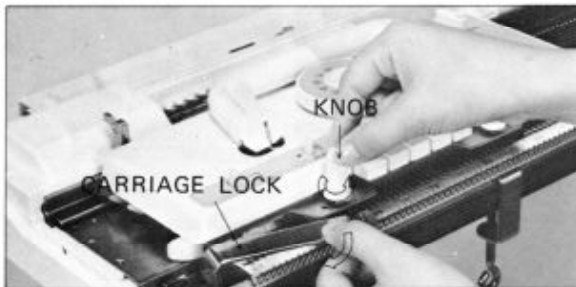

TABLE CLAMPS.



6. Fasten the machine to the table by tightening the TABLE CLAMP SCREWS.



7. Loosen the KNOB and remove the CARRIAGE LOCK.

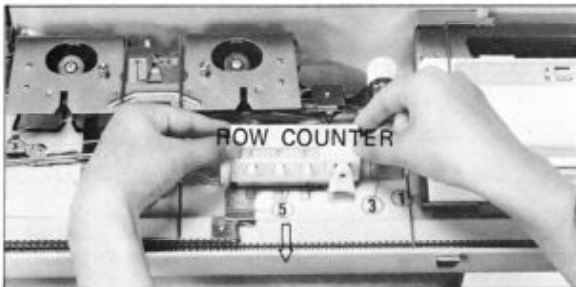
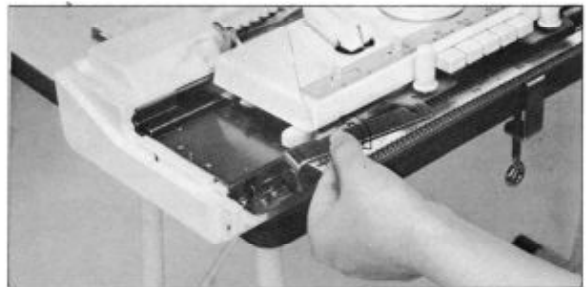

8. Remove the ROW COUNTER from the carrying case.  
1). Push the ROW COUNTER toward you.  
2). Lift it up to remove.

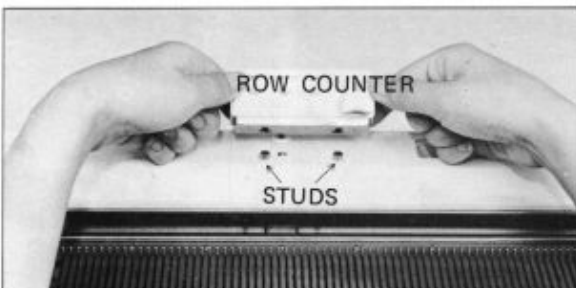

9. Setting up the ROW COUNTER on the two STUDS at the center of the machine.  
1). Set the ROW COUNTER onto the two STUDS.

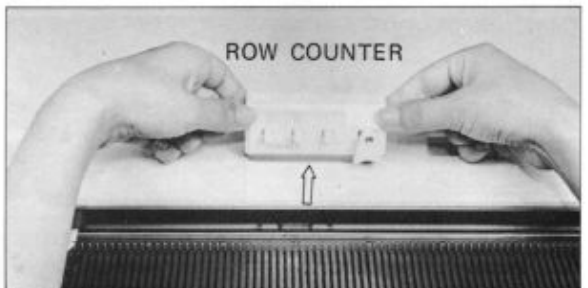

2). Push it away from you.



10. Press down the **SPRING** and remove the **SINKER PLATE ASSEMBLY** from the carrying case.



11. Pull the **CARRIAGE HANDLE** toward you and set it up.



12. Setting up the **SINKER PLATE ASSEMBLY** on the **K CARRIAGE**.  
 1). Loosen the **KNOBS** and insert the **SINKER PLATE ASSEMBLY** under the knobs.



2). Be sure to tighten the knobs so the **SINKER PLATE ASSEMBLY** will fit securely.

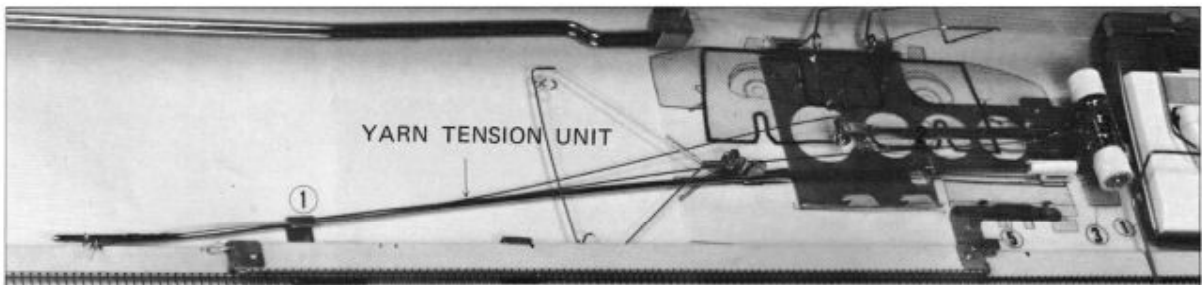

13. Remove the **YARN TENSION UNIT** from the carrying case.  
 1). Take it out of the carrying case in the order of 1, 2 and 3.

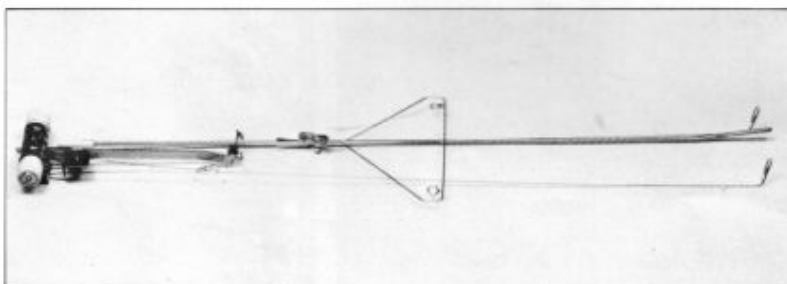

**YARN TENSION UNIT**



14. Setting up the YARN TENSION UNIT.

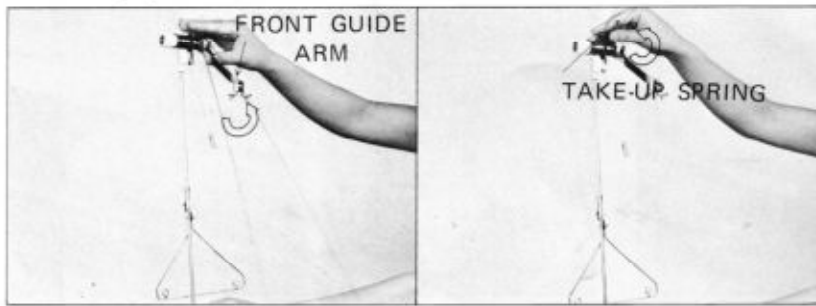

- 1). Turn the FRONT GUIDE ARM forward in the direction of the arrow.
- 2). Turn back the TAKE-UP SPRINGS as far as they will go.

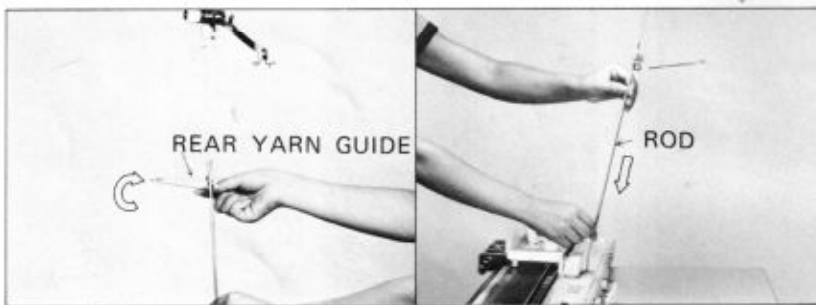

- 3). Raise the REAR YARN GUIDE until it is perpendicular to the rod.
- 4). Insert the end of the ROD into the stand hole at the center of the machine.

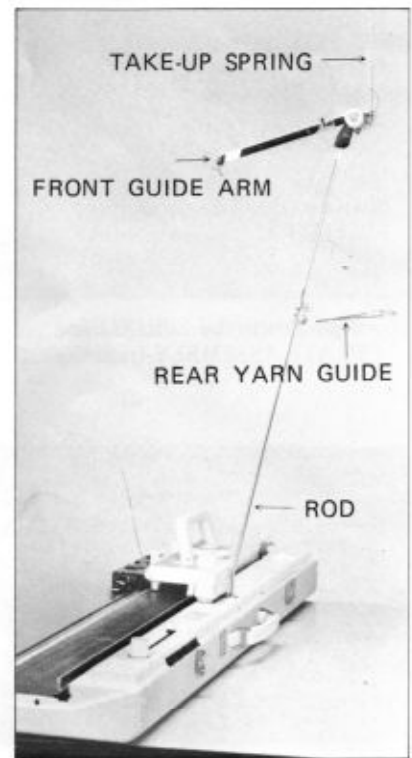

The REAR YARN GUIDE should face backwards.

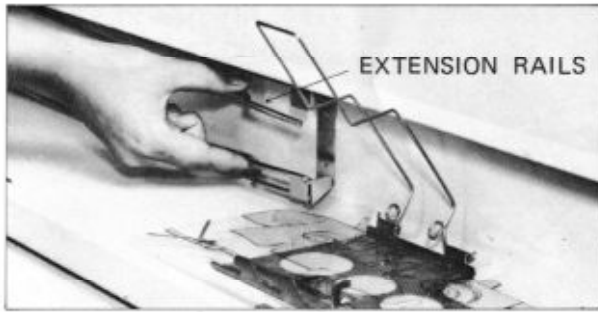

15. Remove the EXTENSION RAILS from the carrying case and set them up on both sides of the machine.

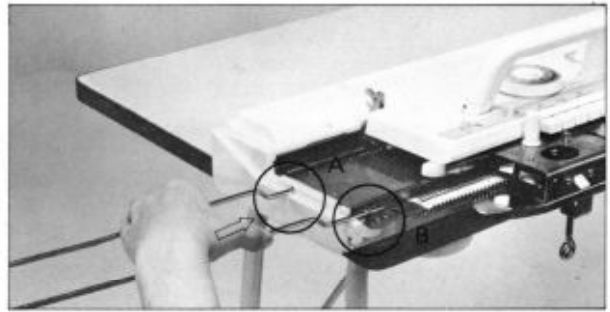

1). Insert EXTENSION RAILS into the holes (A and B) at the both sides of the machine.

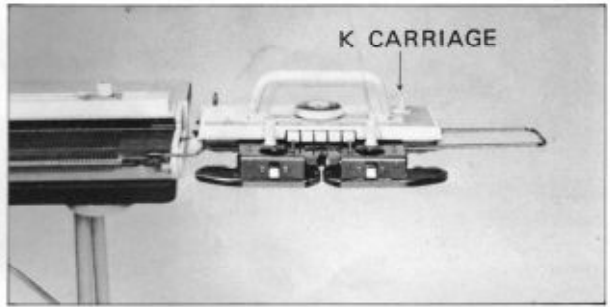
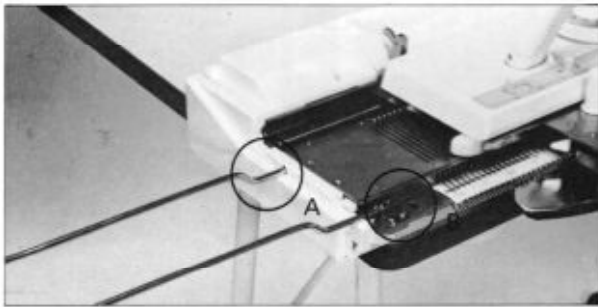

2). Set up the EXTENSION RAILS securely to prevent K CARRIAGE from dropping off.

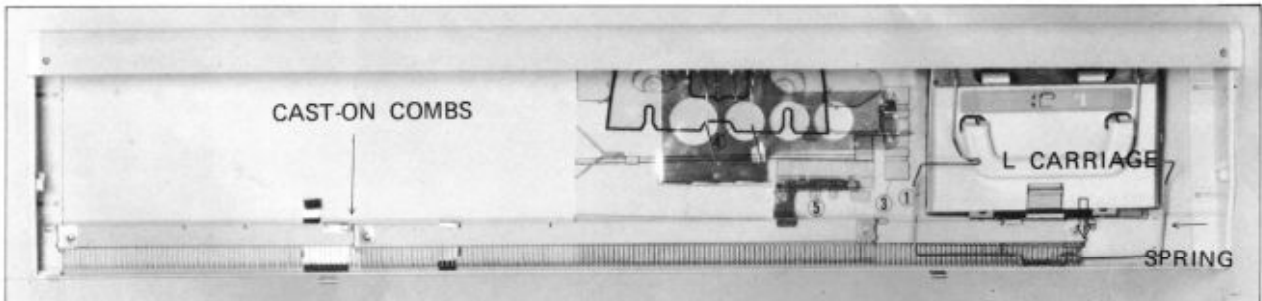

16. Press down the SPRING and remove the CAST-ON COMBS from the carrying case.

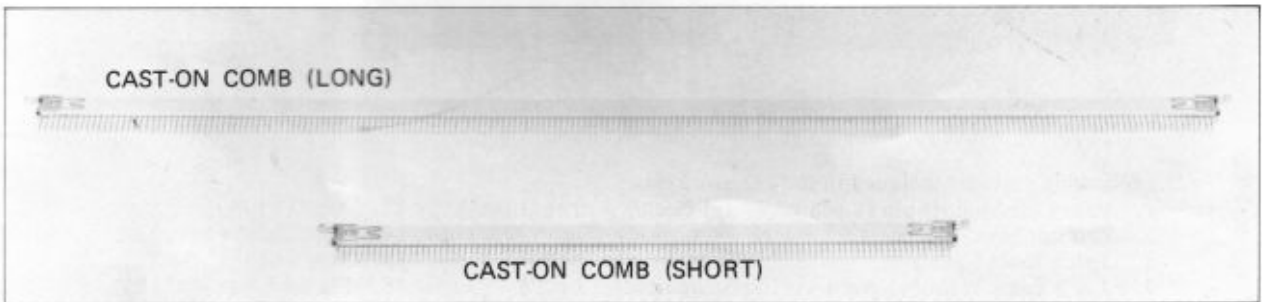

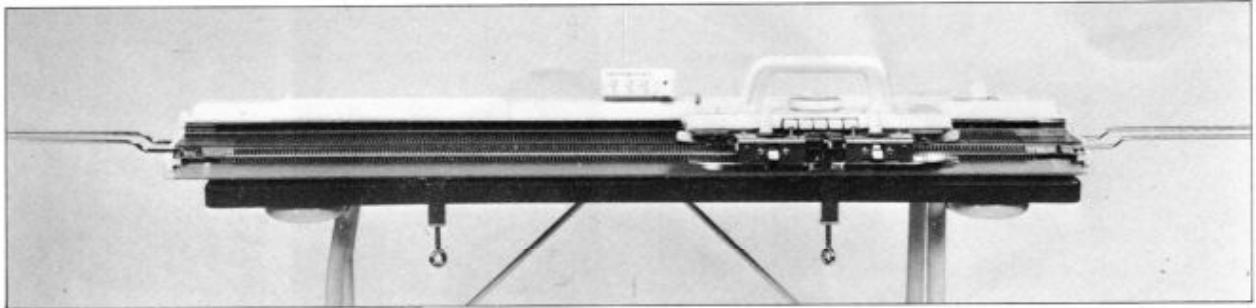

17. After setting up your machine, put the carrying case away.

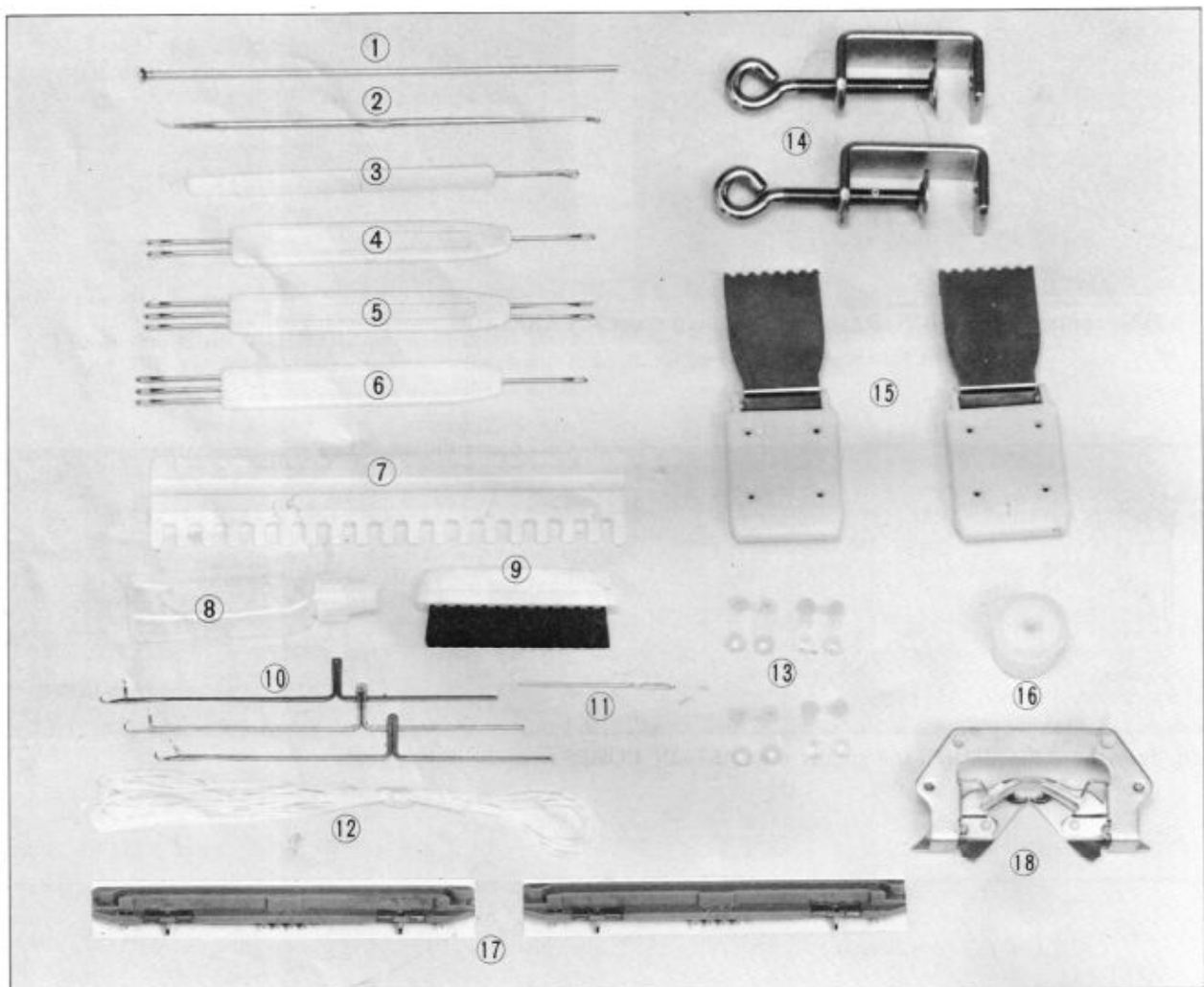

The following parts are included in the accessory box.

- |                                   |                               |                                  |
|-----------------------------------|-------------------------------|----------------------------------|
| 1. Punch card holder pin (1 pce.) | 7. 1/1 Needle pusher (1 pce.) | 13. Snaps (4 pcs.)               |
| 2. Crochet Needle (1 pce.)        | 8. Oil (1 pce.)               | 14. Table clamp (2 pcs.)         |
| 3. Latch tool (1 pce.)            | 9. Hand brush (1 pce.)        | 15. Claw weight (2 pcs.)         |
| 4. 1 x 2 Transfer tool (1 pce.)   | 10. Spare needle (3 pcs.)     | 16. Wax with wax case (1 pce.)   |
| 5. 2 x 3 Transfer tool (1 pce.)   | 11. Tapestry needle (1 pce.)  | 17. One-point cam (2 pcs.)       |
| 6. 1 x 3 Transfer tool (1 pce.)   | 12. Cast-on thread (1 pce.)   | 18. Plating yarn feeder (1 pce.) |

**1-2. FOLDING UP  
YOUR MACHINE**



1. Replace the L CARRIAGE in the carrying case.

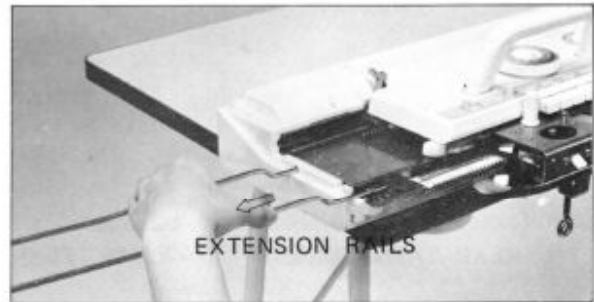

2. Remove the EXTENSION RAILS (lift up and pull).

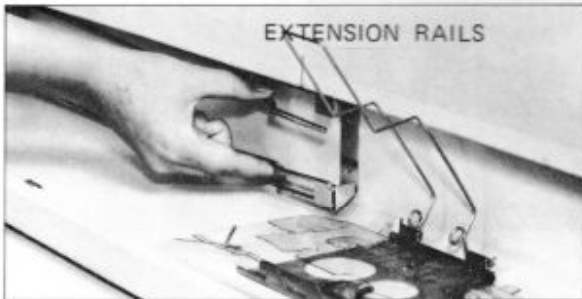

3. Replace the EXTENSION RAILS in the carrying case.

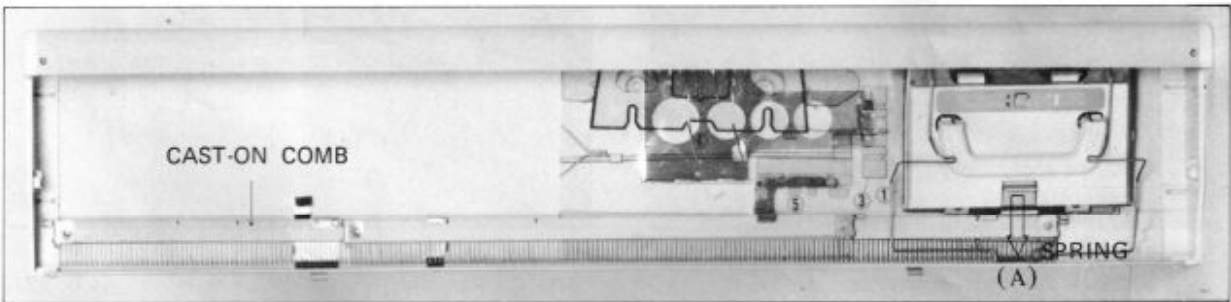

4. Replace the CAST-ON COMBS in the carrying case and set the SPRING to A position.

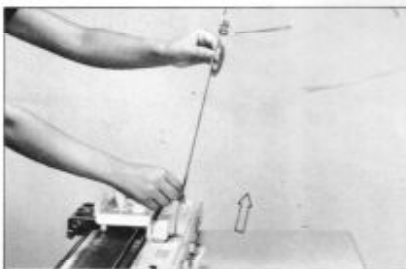

5. Pull out the YARN TENSION UNIT from the machine. Fold up the YARN TENSION UNIT in order as shown in the figures.

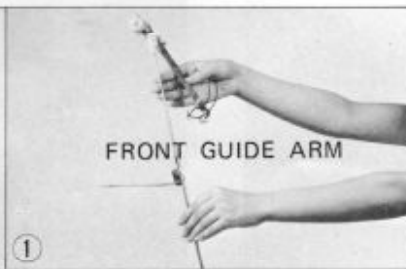

1). FRONT GUIDE ARM.



2). TAKE-UP SPRINGS.

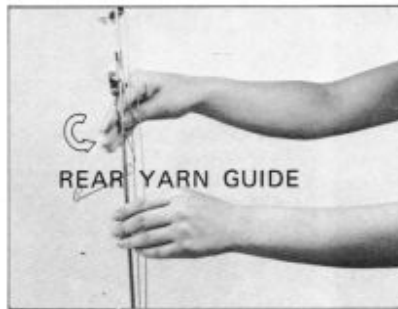

3). REAR YARN GUIDE.

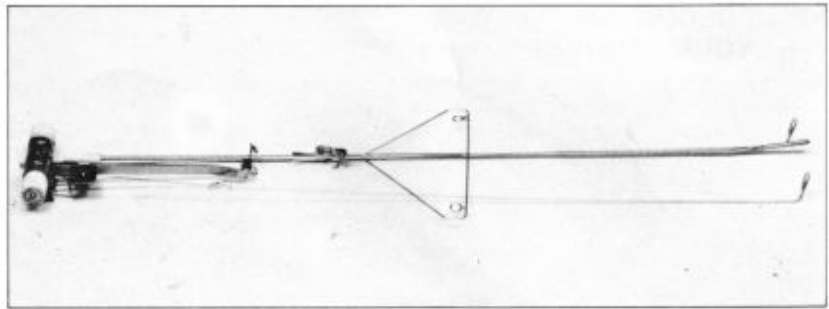

YARN TENSION UNIT.

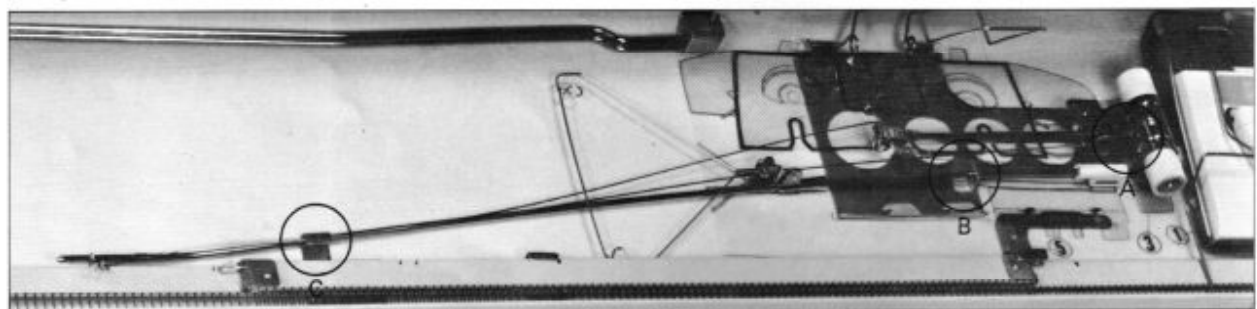

6. Replace the YARN TENSION UNIT in the carrying case.



1). Set the A position of the YARN TENSION UNIT on the figure in carrying case.



2). Set the YARN ROD on B position.

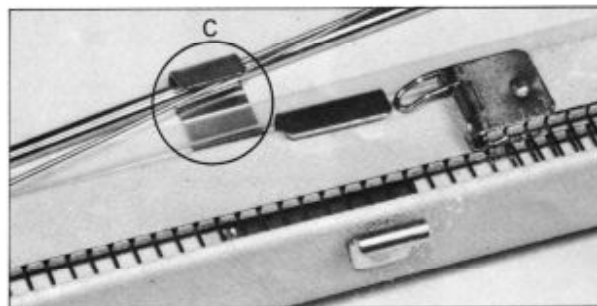

3). Set the YARN ROD and TAKE-UP SPRINGS on C position.

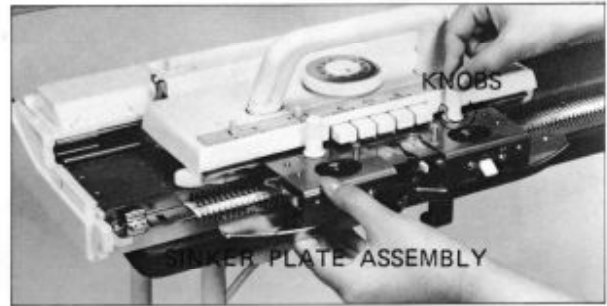

7. Loosen the KNOBS and remove the SINKER PLATE ASSEMBLY from the K carriage.

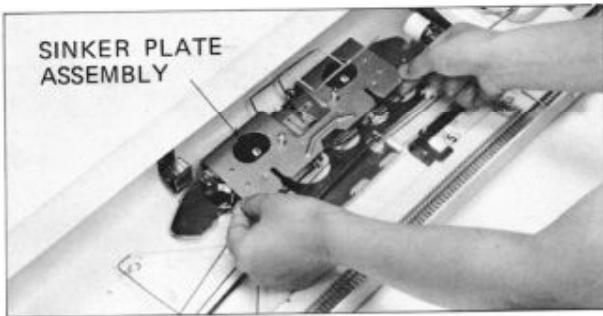

8. 1). Replace it on the corresponding drawing in the carrying case.

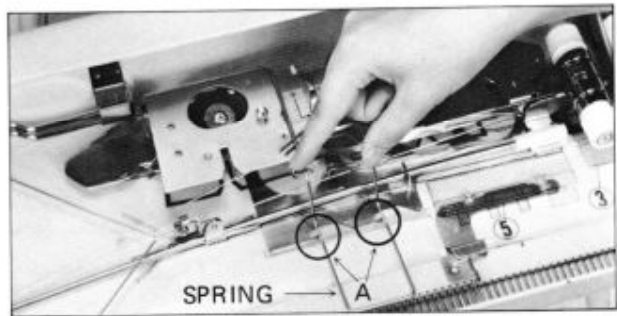

2). Set the SPRING to A position.

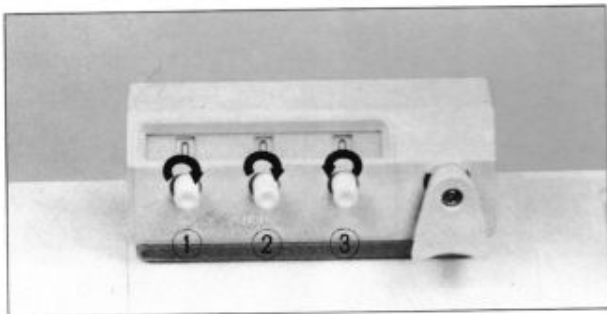

9. Remove the ROW COUNTER from the machine and replace it in the carrying case.

1). The figures on your ROW COUNTER can be moved to zero by turning the dials according to the arrows starting with the dial at the left.

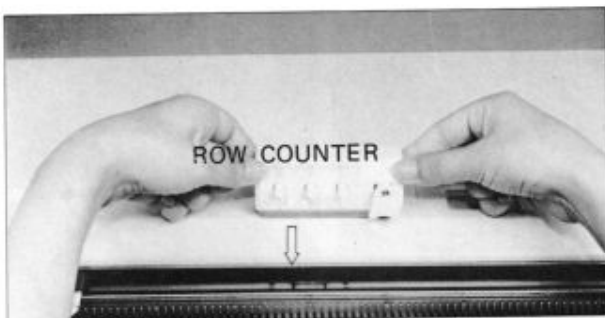

2). Pull the ROW COUNTER toward you and lift it up.

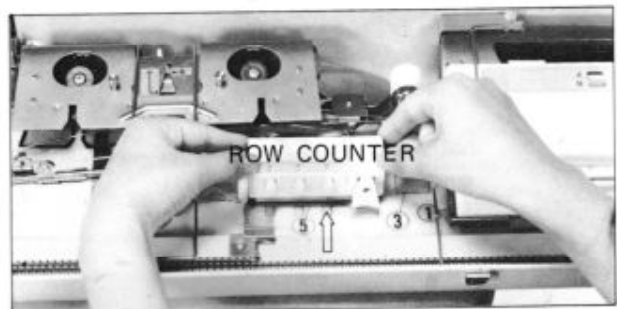

3). Set the ROW COUNTER onto the two studs in the carrying case and push it away from you.



10. Fold up the CARRIAGE HANDLE.

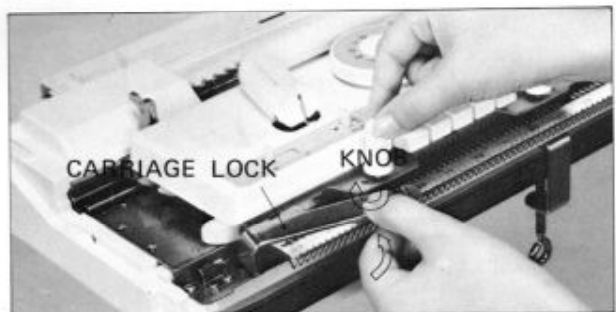

11. Insert the CARRIAGE LOCK in the hole at the left edge of the machine and lock the K CARRIAGE.

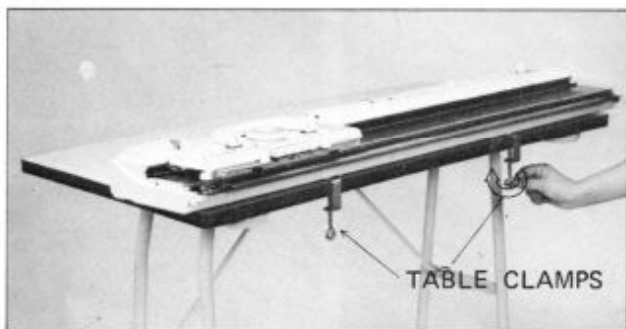

12. 1). Release the two TABLE CLAMPS.

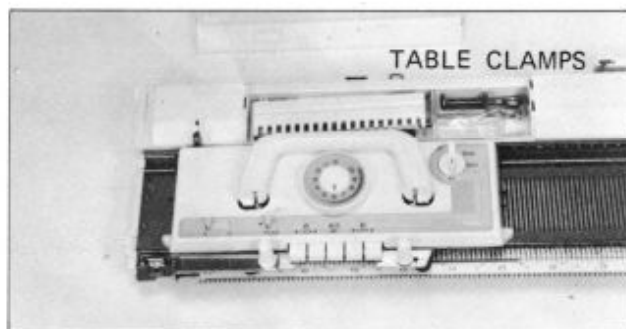

2). Replace the two TABLE CLAMPS in the accessory box.

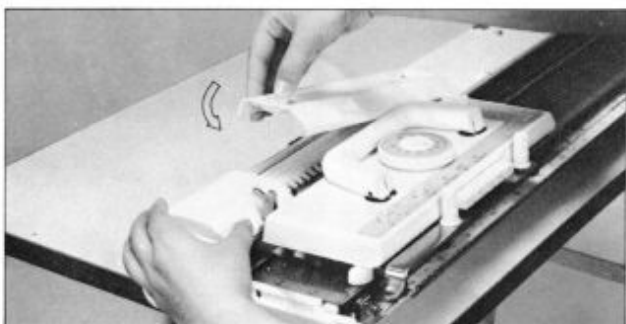

13. Replace the other accessories in the accessory box and close it. Push all needles back to position A.

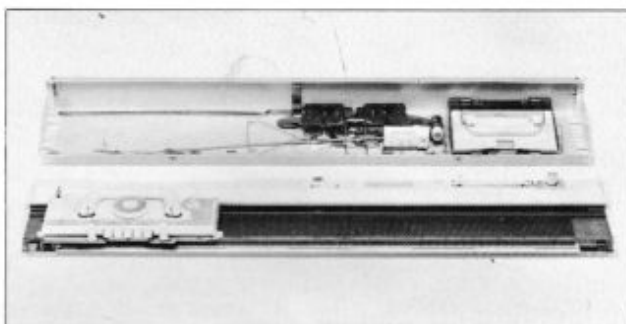

14. After replacing all the accessories.

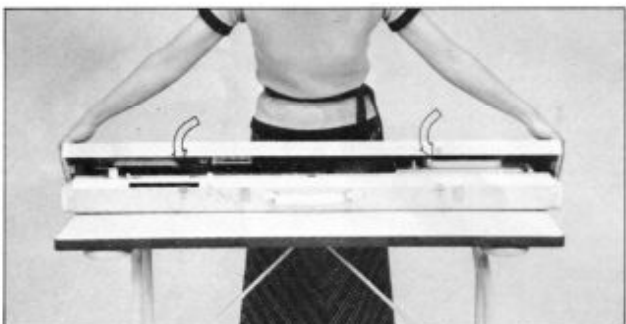

15. Hold the UPPER CASE and close the carrying case as shown in the figure.

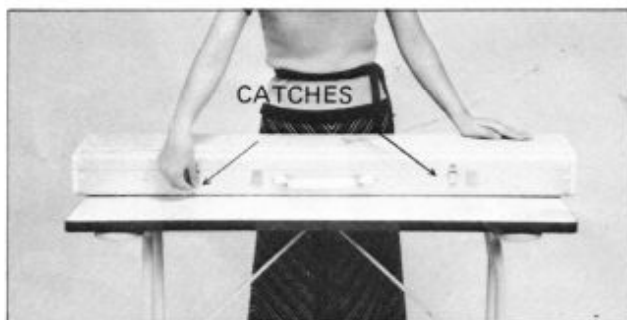

16. Lock the two CATCHES on either side of the handle.

**2. HERE ARE A FEW IMPORTANT POINTS TO REMEMBER BEFORE YOU START KNITTING**

**2-1. PREPARATION OF YARN**

For the beginning.  
It is best to use new yarn.

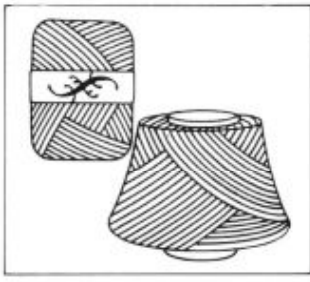
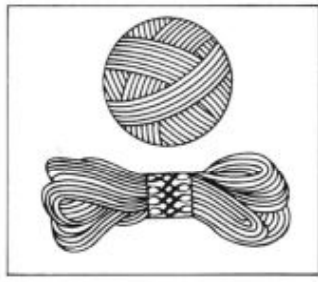

Rewind all yarn like those shown in the above illustration into a ball by using a SKEIN HOLDER and WOOL WINDER.

Yarn like those shown in the above illustration can be used as they stand.

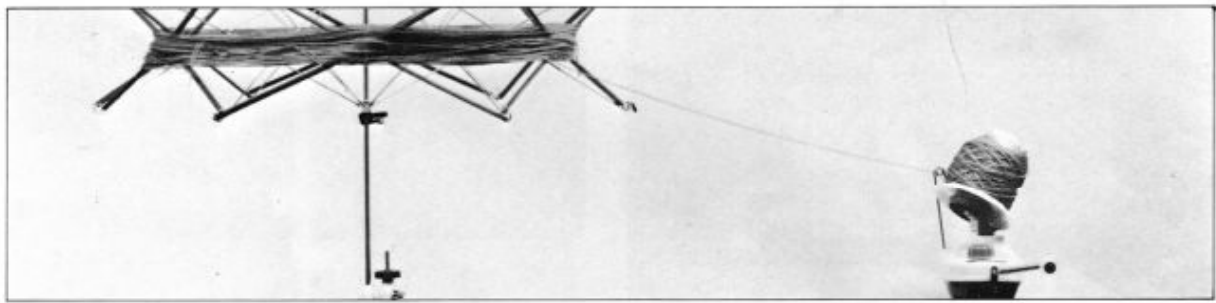

When the wound yarn is pulled from the center of the ball, the yarn must come out freely without lifting the ball from the table.

When the yarn does not come out smoothly, pull the yarn out of the center of the ball.

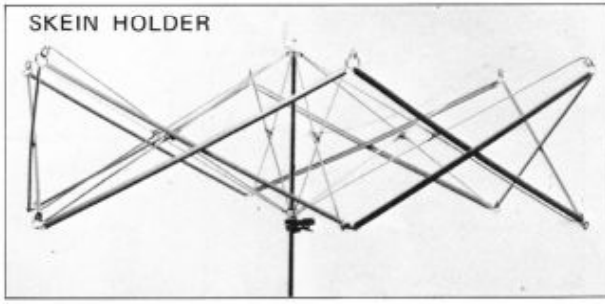

The SKEIN HOLDER and the WOOL WINDER are available separately.



**2-2. THREADING THE YARN TENSION UNIT.**

Thread the YARN TENSION UNIT in order as shown in the right figure.

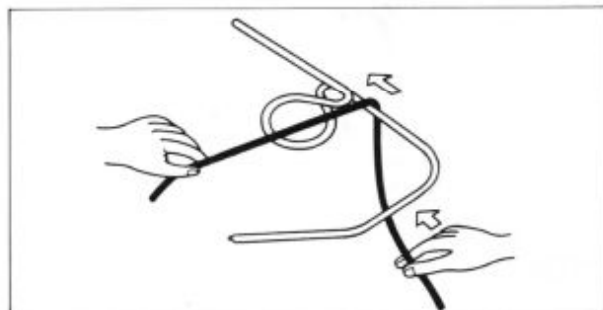
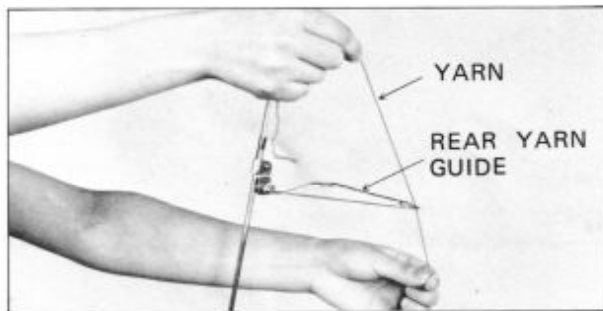
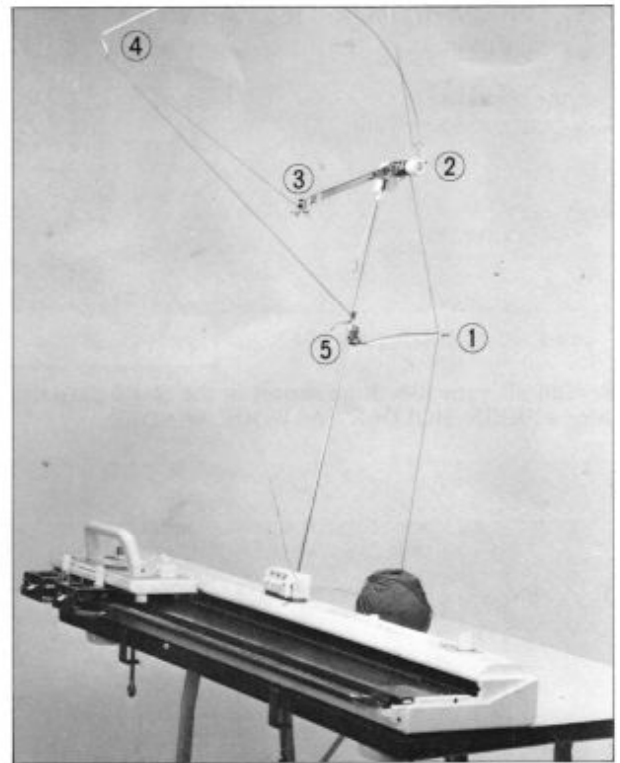

1. Pass the yarn from the ball through the REAR YARN GUIDE sliding the yarn through the eyelet.

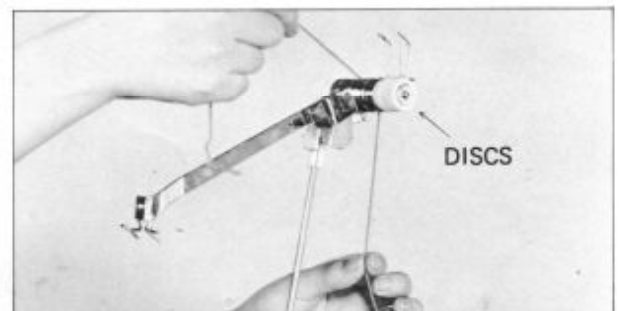

2. Pass the yarn under THE PIN and between the two DISCS from behind.

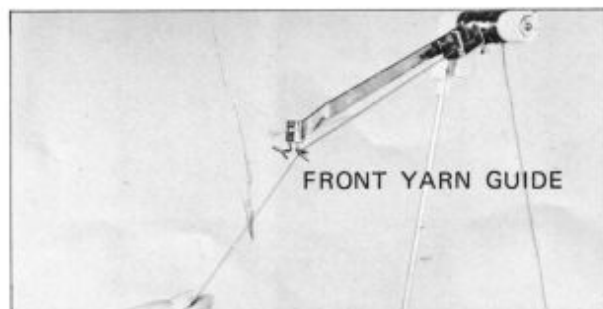

3. Thread the FRONT YARN GUIDE.

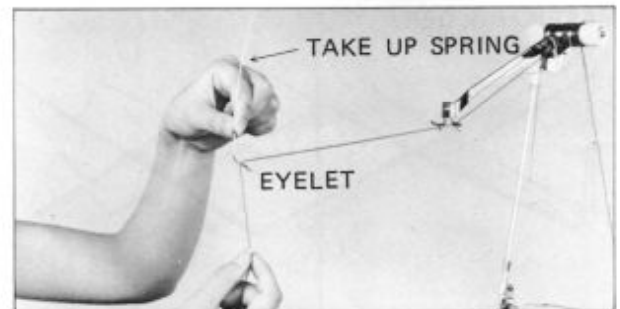

4. Thread the yarn into the EYELET OF THE TAKE-UP SPRING.

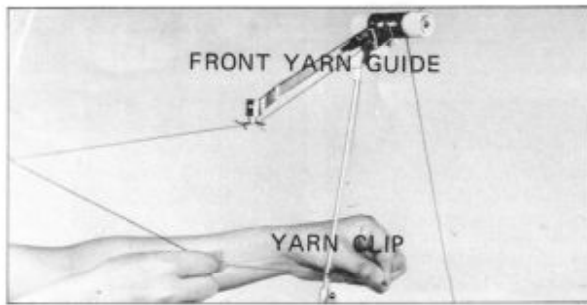

5. Clip the yarn under the YARN CLIP.

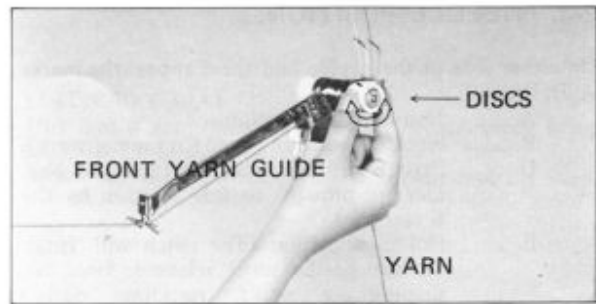

6. Set the arrow mark according to the thickness of yarn as below,

- |             |         |
|-------------|---------|
| Medium yarn | .....▶◀ |
| Thick yarn  | .....▶— |
| Fine yarn   | .....▶+ |

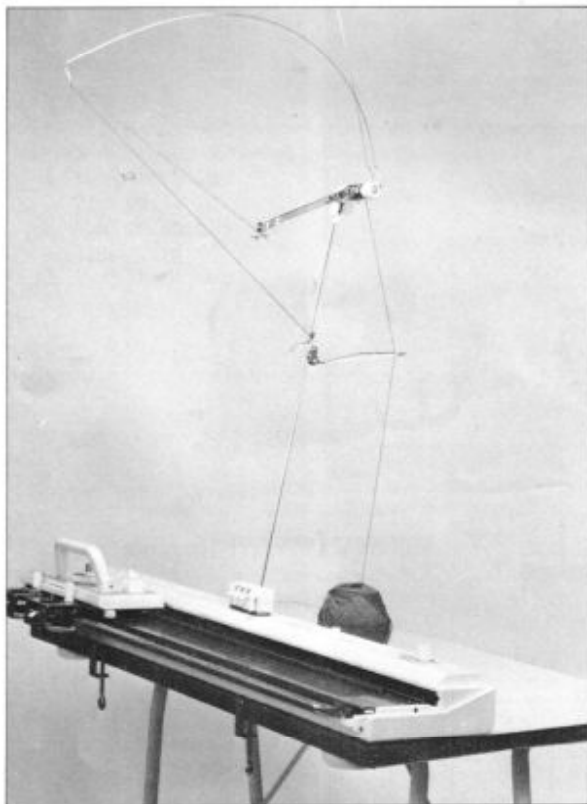

7. After threading the YARN TENSION UNIT.

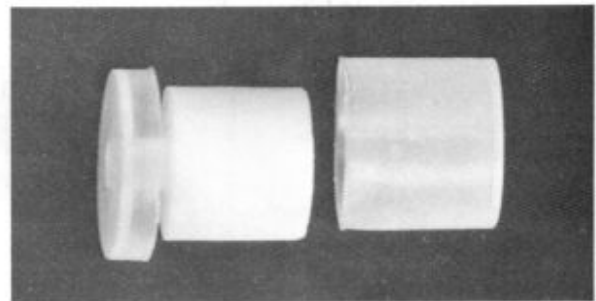

Wax with wax case.

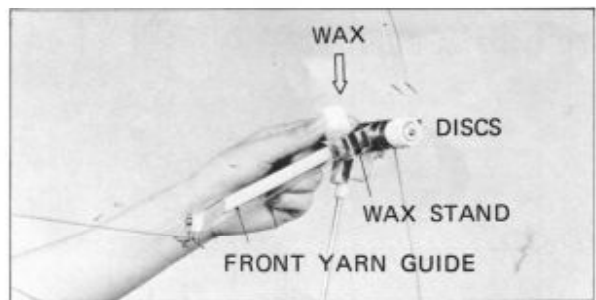

8. When you start knitting, set the WAX from the accessory box on the special stand.

The WAX will help the yarn to slide more smoothly.

### 2.3. NEEDLE POSITION.

On either side of the needle bed there appear the marks A, B, D and E.

- A ..... Non-working position.
- B ..... Working position (Used for general work).
- D ..... Pattern knitting position (Selected Needles are brought to this position by the K carriage).
- E ..... Holding position (The stitch will 'Hold' on the needle until released. Used for shaping e.g. socks, necklines, darts.)

When you fold up the machine, return the needles to position A.

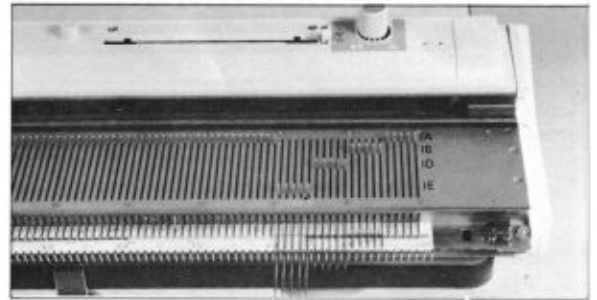

### 2.4. NAME OF PARTS .... K CARRIAGE.

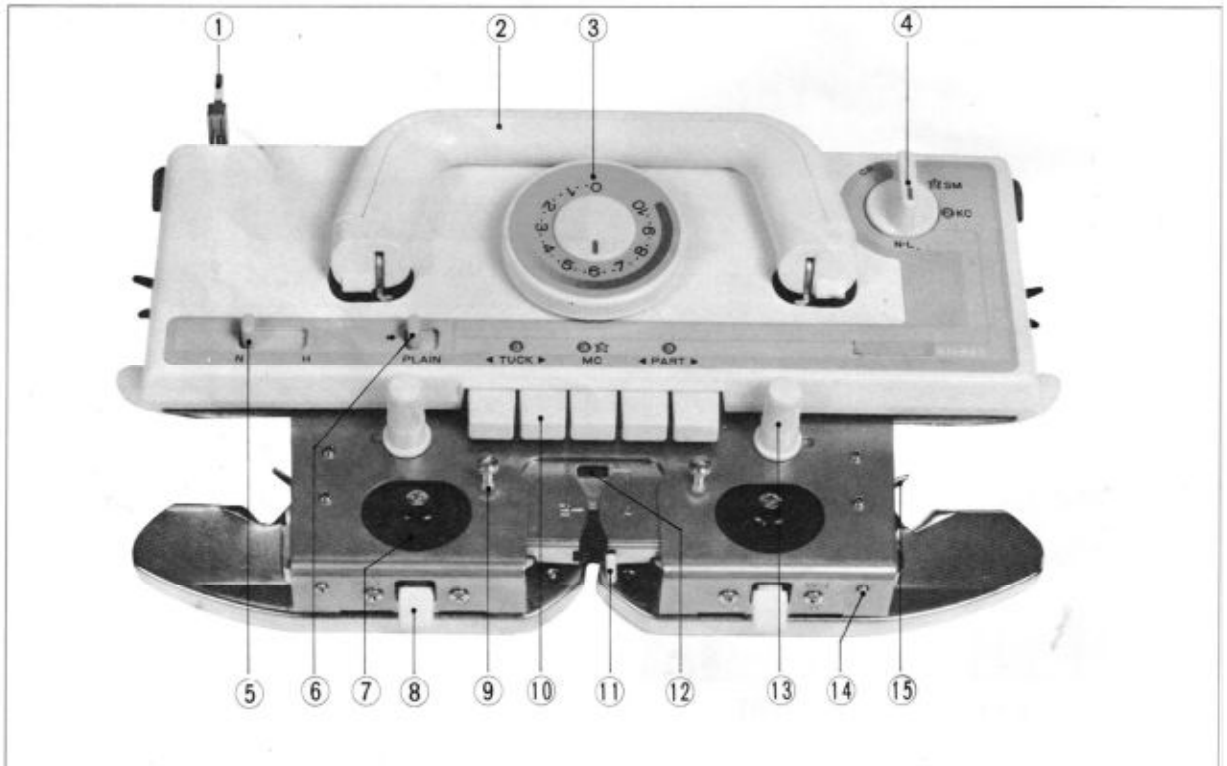

- |                             |                              |
|-----------------------------|------------------------------|
| 1. Row counter tripper      | 9. Yarn feeder setting screw |
| 2. K carriage handle        | 10. Cam buttons              |
| 3. Tension dial             | 11. Yarn feeder lever        |
| 4. Change knob              | 12. Yarn feeder              |
| 5. Holding cam lever        | 13. Knobs                    |
| 6. Cam button release lever | 14. Sinker plate assembly    |
| 7. Weaving pattern brush    | 15. Weaving yarn guide       |
| 8. Weaving pattern lever    |                              |

## 2-5. RELATION BETWEEN THE TENSION DIAL AND YARN



### 1. TENSION DIAL

This dial is graduated from 0 to 10, each space being subdivided into three parts.

Adjust the dial according to the thickness of the yarn.

### 2. YARN

The various thicknesses of yarn as distinguished as follows. Yarns are shown in the right figure.

1. Very fine yarn
2. Fine yarn
3. Medium yarn
4. Thick yarn
5. Very thick yarn

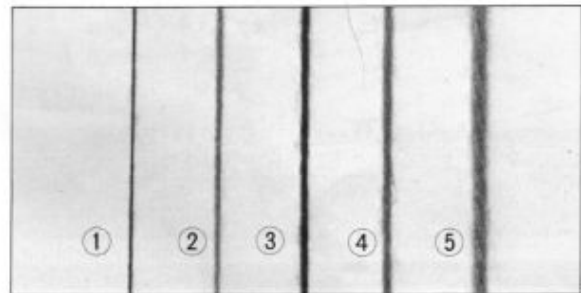

There are too many types of yarn to show all of them here and each type of yarn requires its own Tension Dial (T.D.) number.

So, find the proper Tension Dial (T.D.) number by referring to the following table.

Type of yarn	Recommended T.D. number
1. Very fine yarn	1 ~ 3
2. Fine yarn	3 ~ 5
3. Medium yarn	5 ~ 7
4. Thick yarn	7 ~ 9
5. Very thick yarn	8 ~ 10

Remarks; For very thick yarn or bulky yarn, use every other or every third needle.

### 3. BASIC OPERATION PRACTICE I (PLAIN KNITTING)

#### 3-1. PLAIN KNITTING.

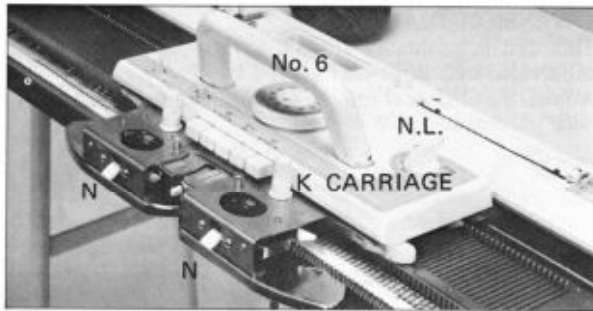

1. Set the K CARRIAGE.  
(The following instructions are explained based on Tension dial number 6.)

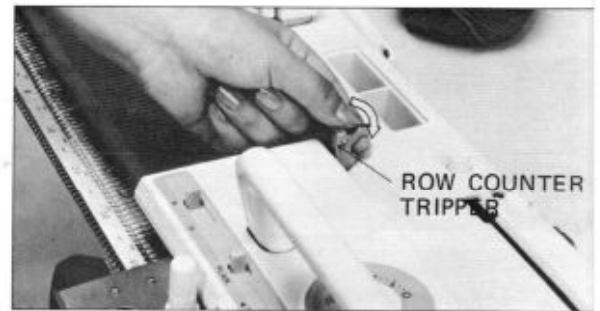

- When using the ROW COUNTER, set the ROW COUNTER TRIPPER to working position.

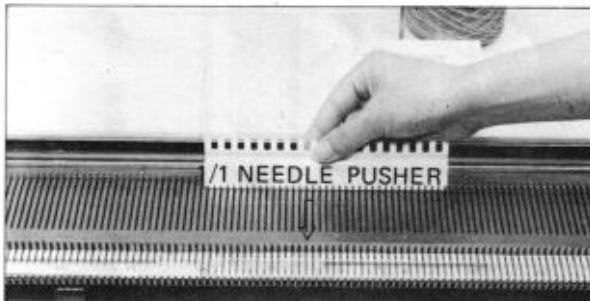

2. Using the 1/1 NEEDLE PUSHER bring forward 60 needles to position B. (30 needles on either side of the center mark "0".)

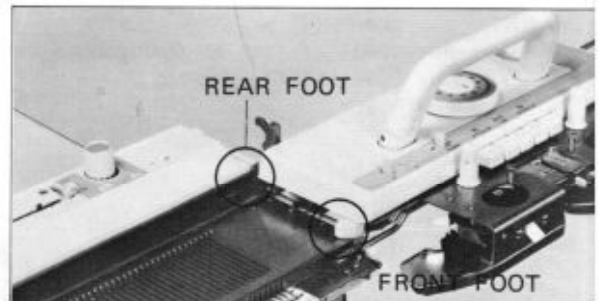

3. After seeing that the REAR and FRONT FEET of the K CARRIAGE are set on the NEEDLE BED correctly, move the K CARRIAGE across and back to straighten these needles into position B.

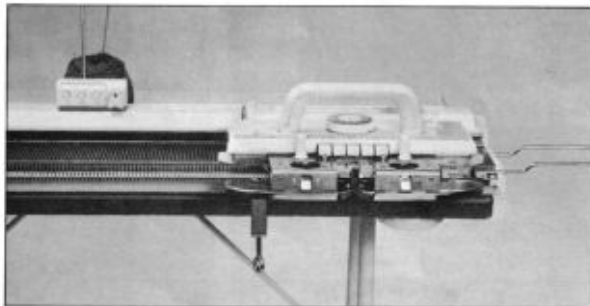

Place the K CARRIAGE at right side of the machine.

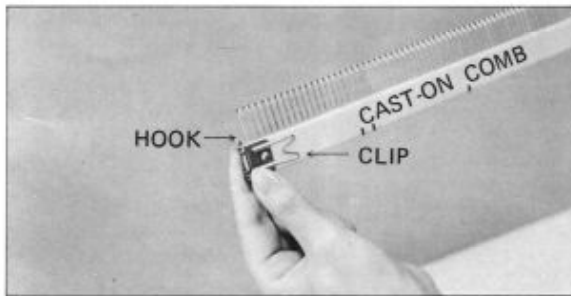

4. For cast-on, hang the CAST-ON COMB on the GATE PEGS of the machine.

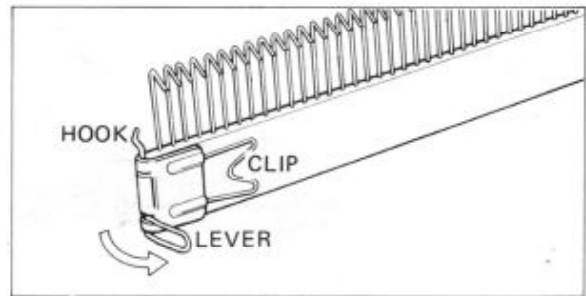

1). Hold the CAST-ON COMB, with the clip facing you, and turn levers at both sides to you.

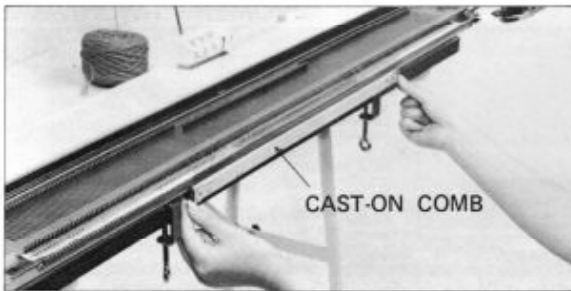

2). Place both HOOKS on the GATE PEGS as shown in the figures.

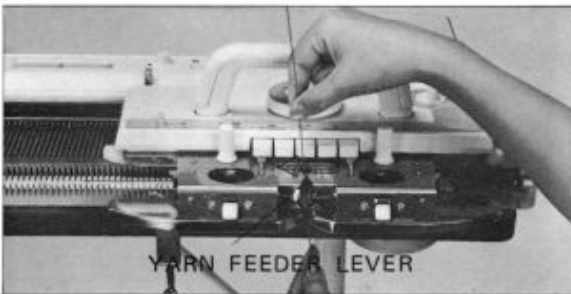
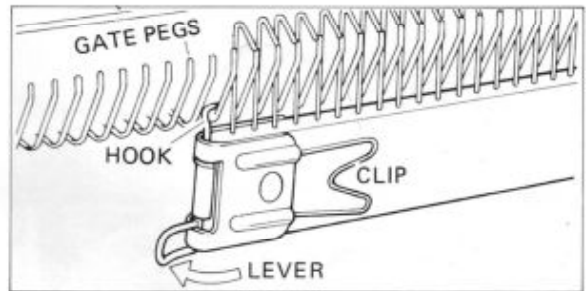

5. Turn the YARN FEEDER LEVER to the left and take the end of the yarn (which has been clipped onto the YARN TENSION ROD). Thread it into the YARN FEEDER "A" for main yarn. Hold the yarn from below with your left hand and from above with your right. Then put the yarn into the YARN FEEDER "A".



6. Hold the end of the yarn with your left hand under the YARN FEEDER "A". Close the YARN FEEDER LEVER.

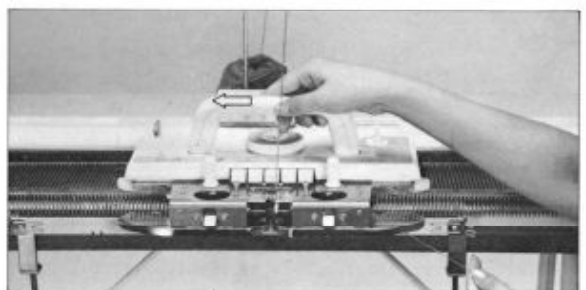

Move the K CARRIAGE to the left, holding the end of the yarn with your left hand. (When moving the K CARRIAGE, keep your left hand at the right edge of the knitting).

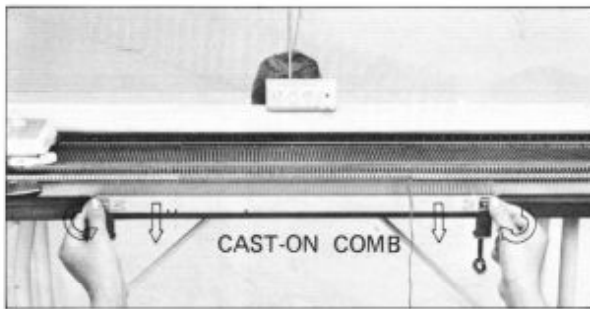

7. Remove the CAST-ON COMB from the GATE PEGS. Lower the CAST-ON COMB by turning the levers at both sides (at the same time) toward you. Make certain that the COMB PEGS catch the yarn between each GATE PEG.

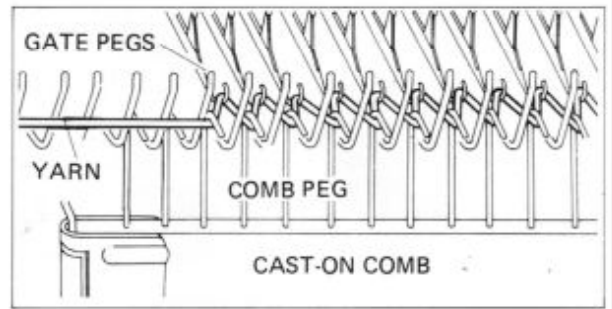

8. Release the yarn between the COMB and the K CARRIAGE, so that it may go under the last COMB PEG, adjacent to the end needle and above the rest.

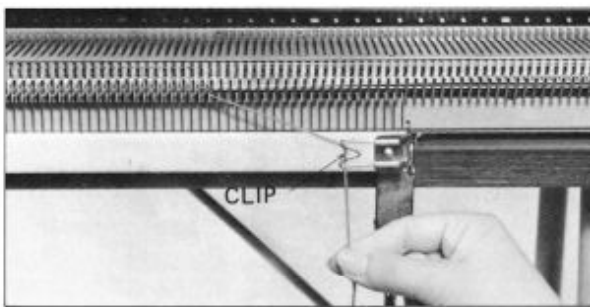

Clip the right end of the yarn as shown in the figure.

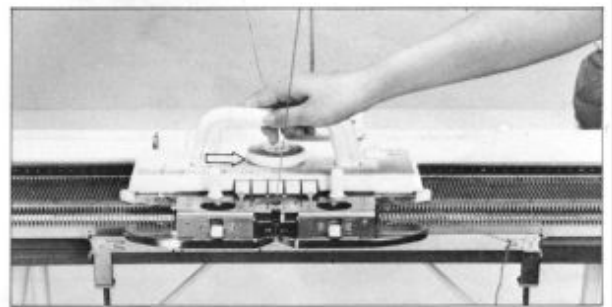

9. Move the K CARRIAGE to the right slowly.

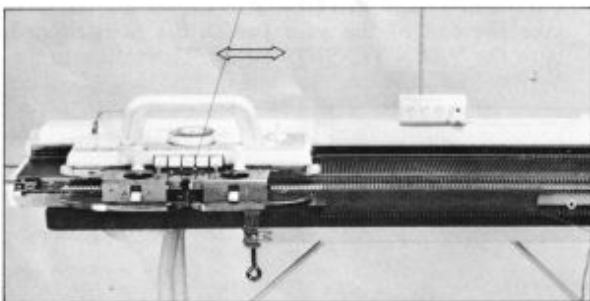

10. Continue to operate the K CARRIAGE back and forth. You are doing plain knitting.

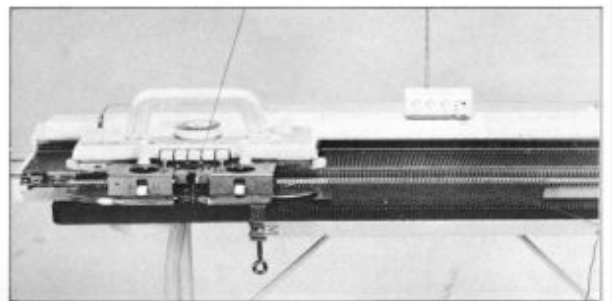

Always move the K CARRIAGE across until you hear the "CLICK" at end of a row. Continue knitting each row at the same speed.

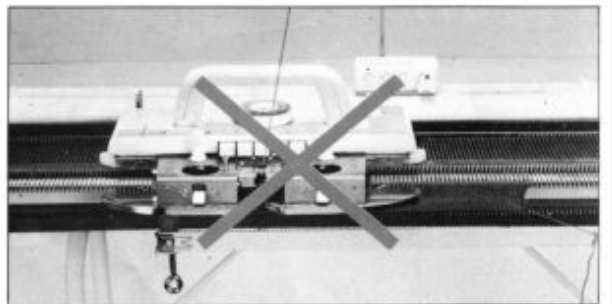
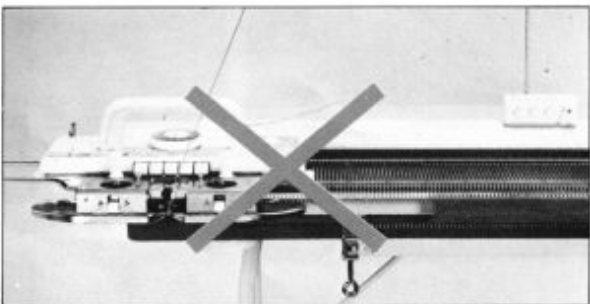

Do not move K CARRIAGE too far beyond the knitting, and do not reverse K CARRIAGE in the middle of a row.

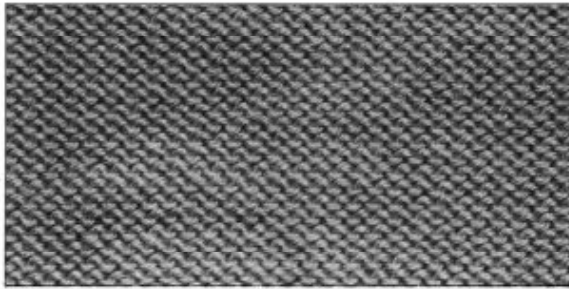

The purl side.  
When knitting, this side is facing you.

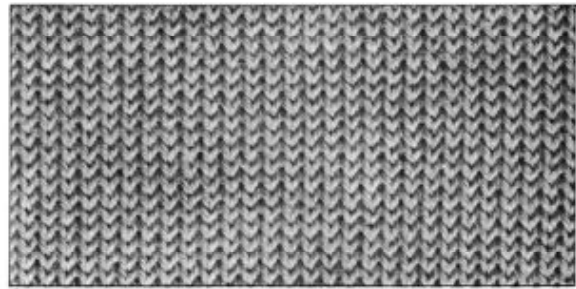

The plain side.  
When knitting, this side is away from you.

### 3-2. HOW TO REMOVE THE KNITTING FROM THE MACHINE.

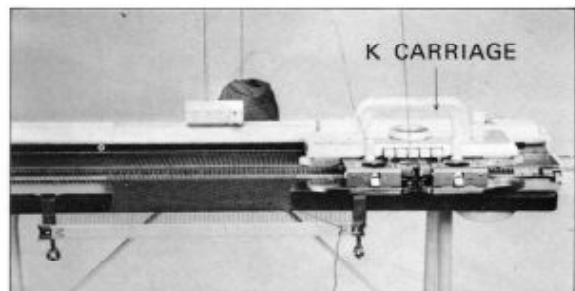

1. Place the K CARRIAGE on the right side.

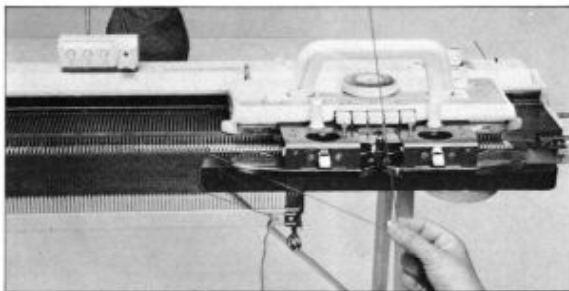

2. Take the yarn out of the YARN FEEDER "A".

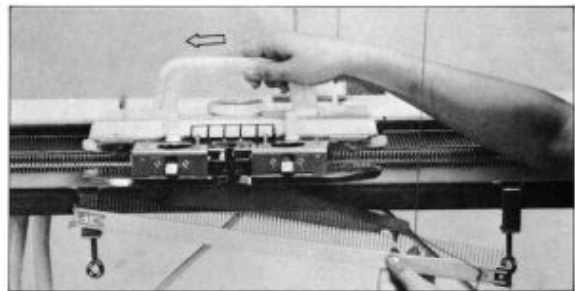

Move the K CARRIAGE to left holding the knitting.  
The knitting will be removed from the machine.

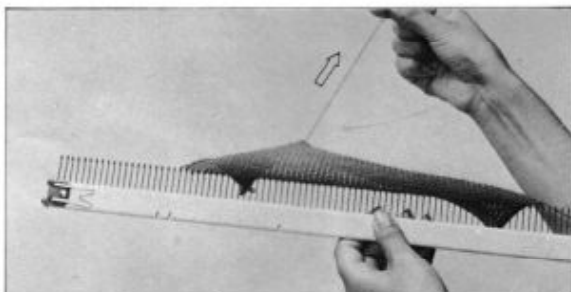

As the knitting is not finished off, it will unravel easily.

Plain knitting is the basic way to knit, so practice this until you can do it smoothly from the beginning.



### 3-3. CAST-ON WITH A FINISHED EDGE.

#### 3-3-1. Hand Method.

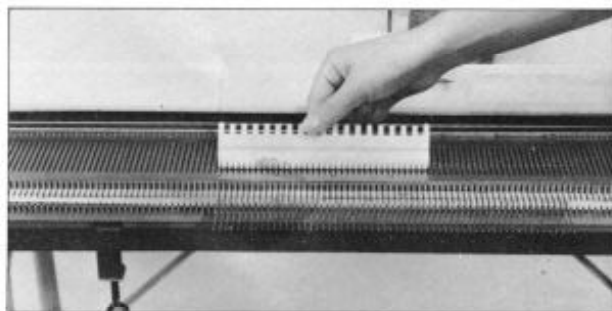

1. Place the K CARRIAGE on the right and bring forward to position E all the needles required.



2. Hang the CAST-ON COMB onto the GATE PEGS.

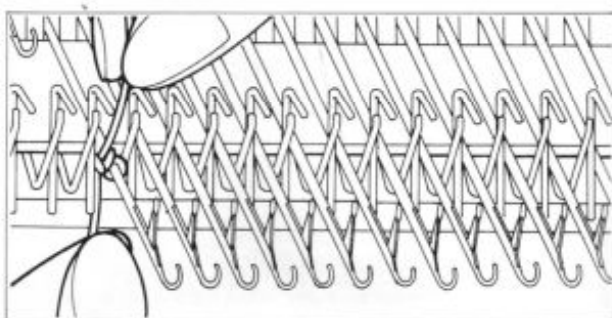

3. Make a loop and fasten the end of the yarn threaded through the YARN TENSION UNIT onto the end needle on the left.

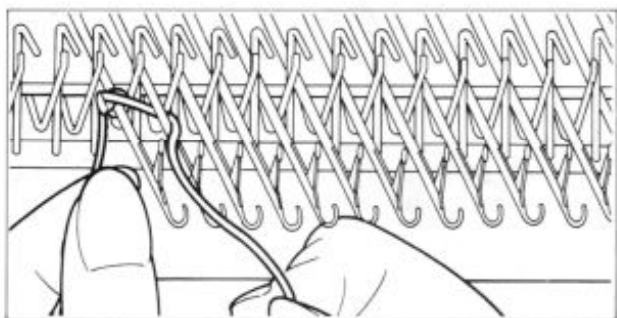

4. 1). Loop the yarn around the second needle from left, counterclockwise.

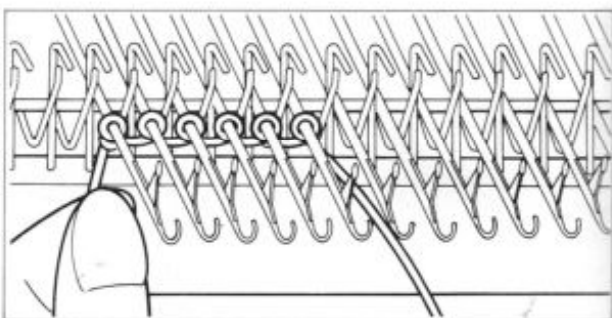

- 2). Loop the yarn around each needle from left to right in the same way.

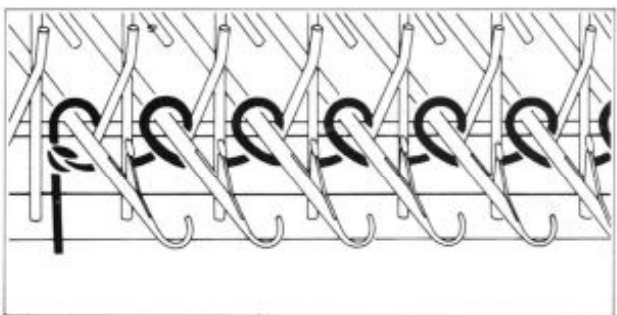

- 3). The loops must be pushed back on the stems of the needles. Do not make the loops too tight.

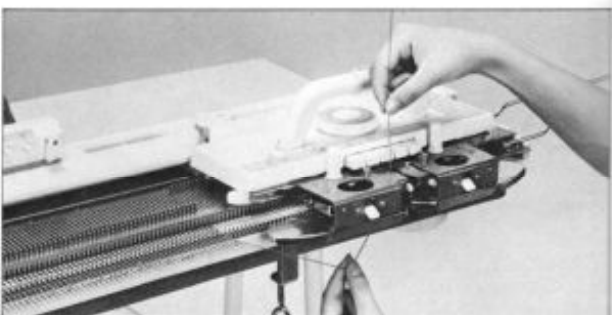

- 4). After looping the yarn around each needle, thread the yarn into the yarn feeder "A".

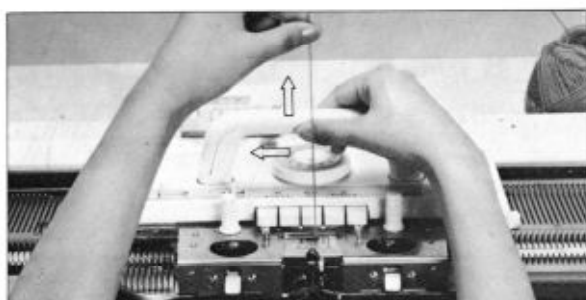

5. Move the K CARRIAGE from right to left lifting the yarn up slightly.

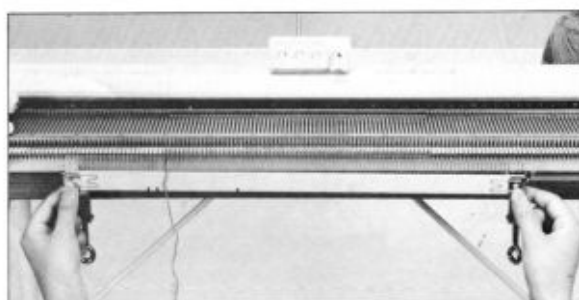

Release the CAST-ON COMB.  
Continue to operate the K CARRIAGE, then you will have plain knitting.

### 3-3-2. Latch Tool.

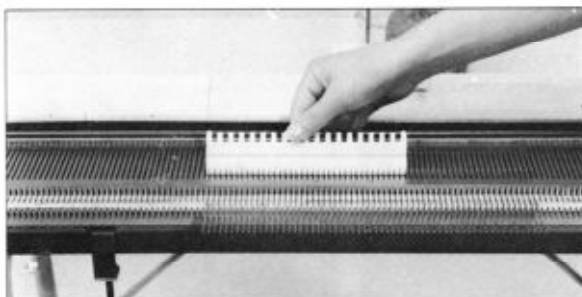

1. Place the K CARRIAGE on the right and bring forward to position E all the needles required.



2. Hang the CAST-ON COMB onto the GATE PEGS.

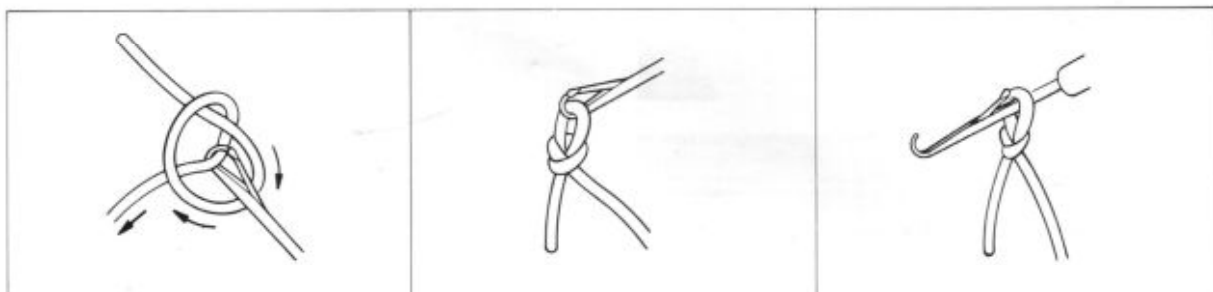

3. Make the chain stitch by using the latch tool.

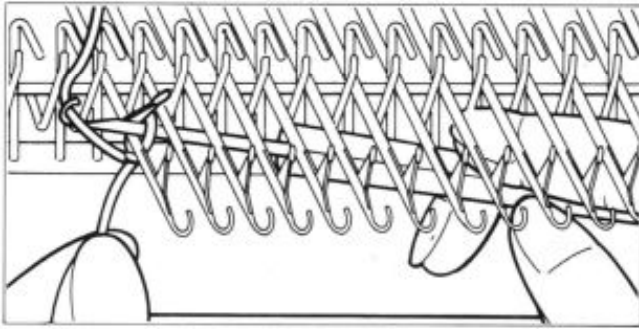

4. With the loop behind the latch, put the LATCH TOOL between the left edge needle and the second needle and make a stitch.  
 1). Push the LATCH TOOL up and hook the yarn.

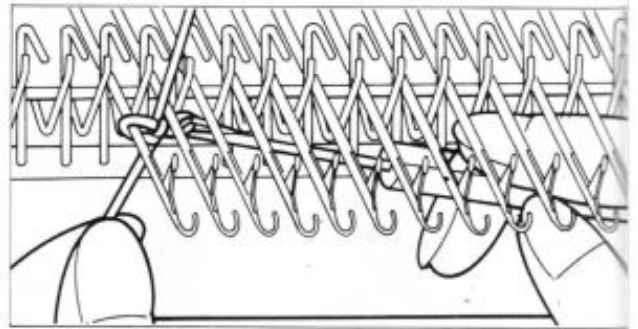

- 2). Pull the LATCH TOOL through the loop on the stem of the latch tool. Now you have made a stitch.

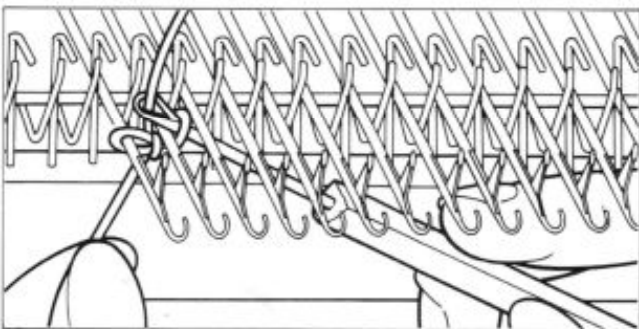

- 3). Repeat this, and when you get to the right, do not make the stitch. Transfer the yarn to the needle hook.

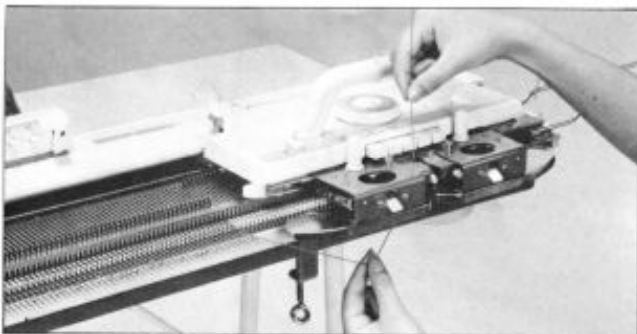
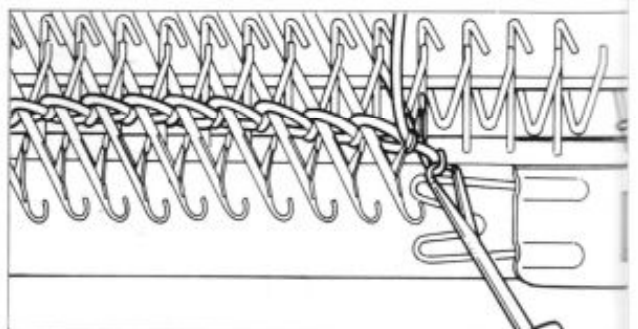

4. Thread the yarn into the YARN FEEDER "A".

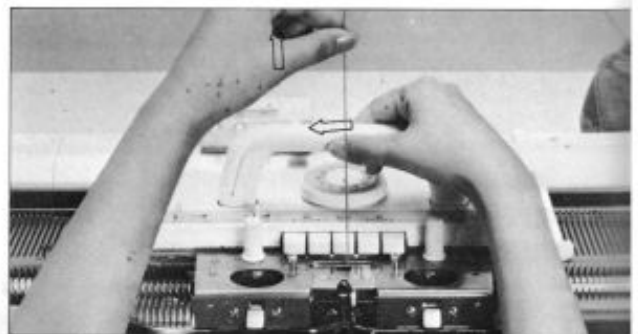

5. Move the K CARRIAGE to the left lifting the yarn up slightly.

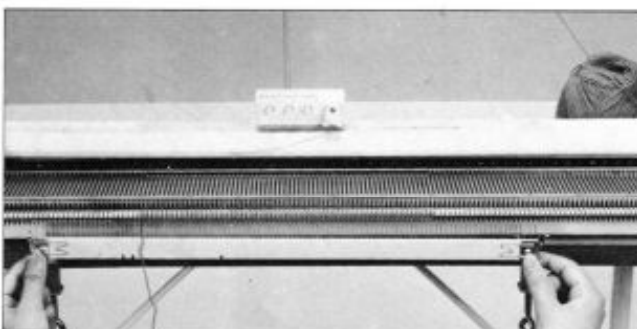

Release the CAST-ON COMB.  
 Continue to operate the K CARRIAGE, then you will have plain knitting.

#### 4. KNOWLEDGE OF PLAIN KNITTING

##### 4-1. WHEN YOU CANNOT CAST-ON WELL.

WHEN THE NEEDLES DO NOT CATCH THE YARN

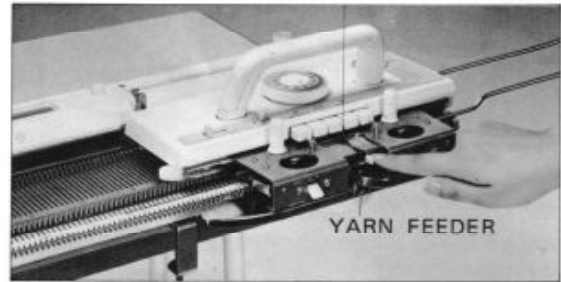

1. Make sure that the yarn is in the YARN FEEDER "A" exactly. If not, you cannot knit.

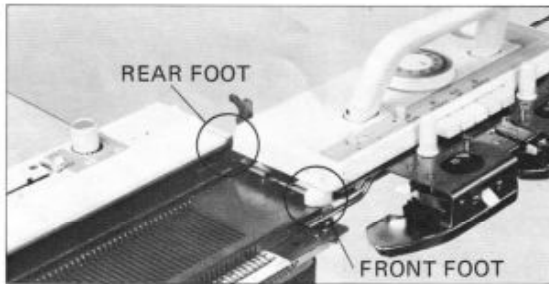

2. Make sure that the K CARRIAGE is set on the needle bed correctly.

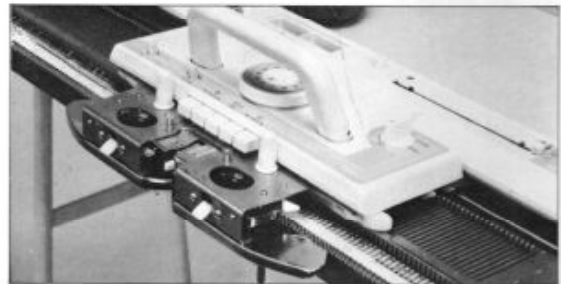

3. Make sure that the CHANGE KNOB is set to position N-L.



4. Make sure that the SINKER PLATE ASSEMBLY is set on the K CARRIAGE correctly.

##### 4-2. WHEN THE K CARRIAGE IS HARD TO PUSH.

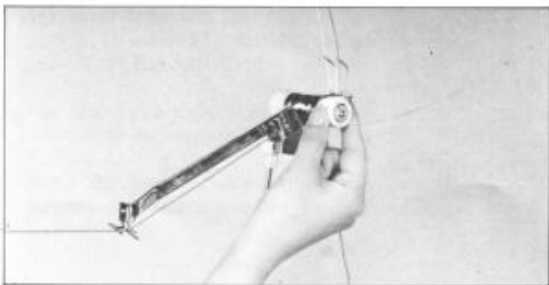

1. Make sure that the TENSION DIAL is adjusted according to the thickness of the yarn. We cannot show you which tension dial number you should use, because there are various kinds of yarn.

Find the proper number yourself by referring to the table.

Type of yarn	Tension dial	Tension disc
Fine yarn	1 ~ 5	▶+
Medium yarn	5 ~ 7	▶◀
Thick yarn	7 ~ 10	▶-

**3-3-3. Using the Weaving Pattern Lever and 1/1 Needle Pusher.**

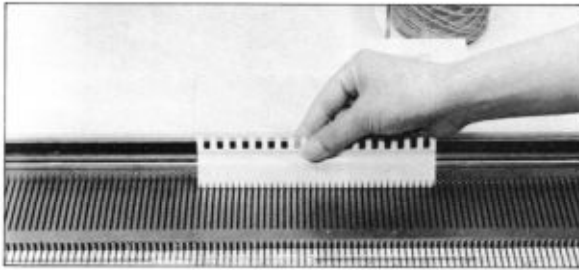

1. Bring forward the required needles to position B.



3. Using 1/1 NEEDLE PUSHER, bring forward every other needle to position D.

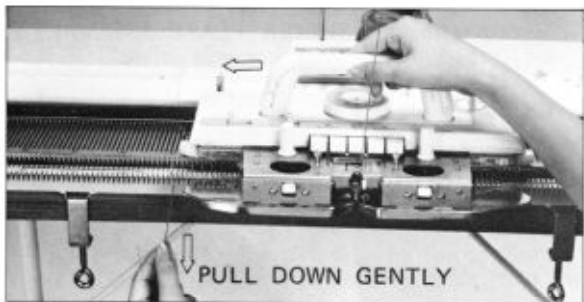

5. Pulling the yarn down gently with the left hand, move the K CARRIAGE to knit slowly with right hand. Continue to hold the end of yarn with left hand for few rows.

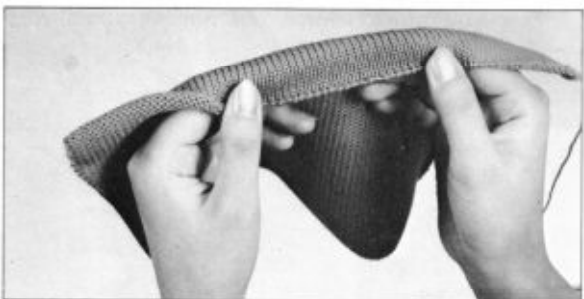

7. Now you can make plain knitting with finished edge.

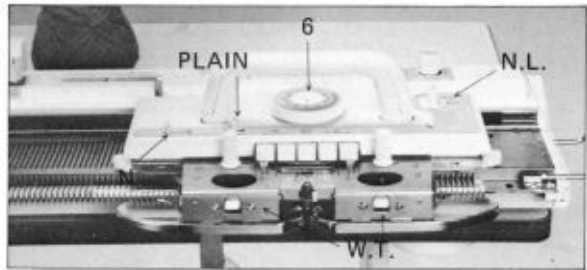

2. Set the K CARRIAGE as shown in the figure and place it on the right side of the machine.



4. Thread the yarn into the yarn feeder "A". Holding the end of the yarn in your left hand, lay the yarn over the selected needles as shown. Hold the end of the yarn as shown in the figure.

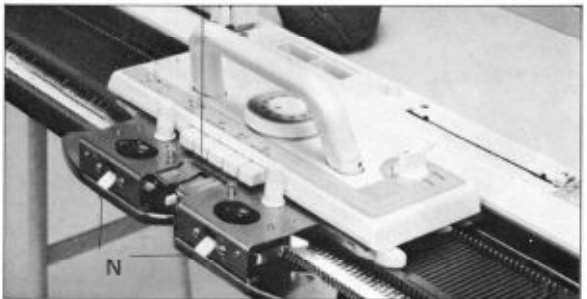

6. Return the Weaving pattern lever to N, and let go the grasp of the left hand after knitting a few rows.

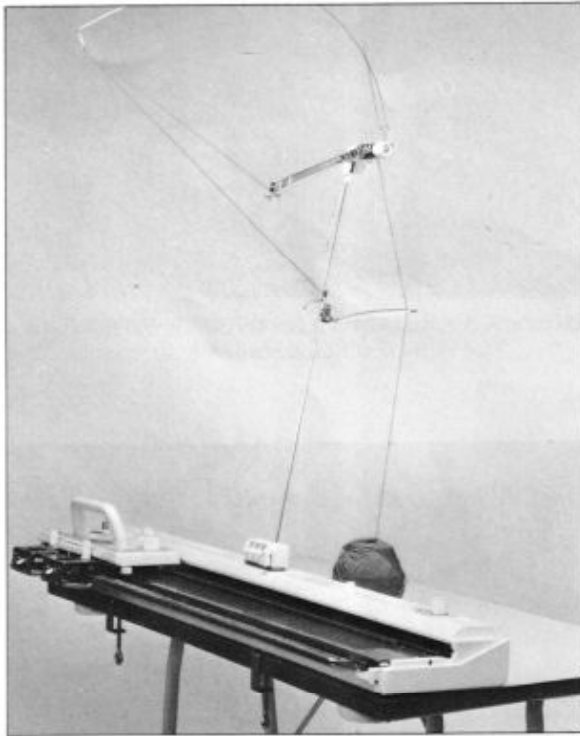

2. Make sure that you thread the yarn into the YARN TENSION UNIT correctly and that the yarn comes out smoothly.

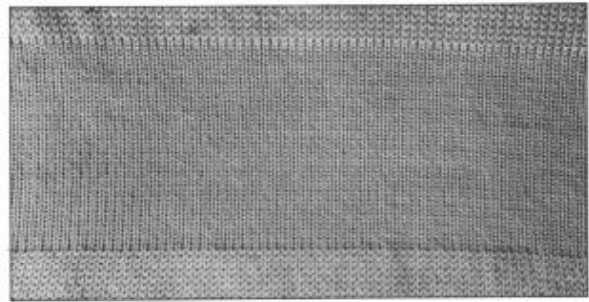

Comparison of the knitting.

1). TENSION DIAL is tight.

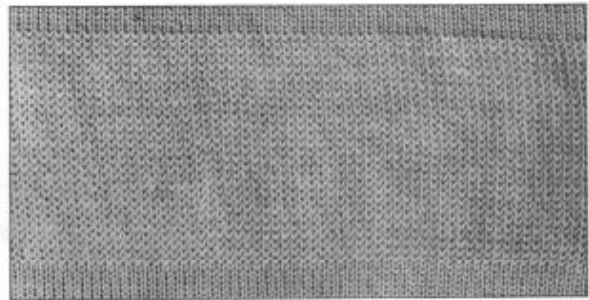

2). TENSION DIAL is loose.

When the stitches are too tight or too loose, adjust the TENSION DIAL to a higher or lower number and get the correct stitch size.

#### 4-3. IF THE K CARRIAGE SHOULD JAM.

Do not move the K CARRIAGE by force. Remove the K CARRIAGE and start knitting again from the beginning of the row.

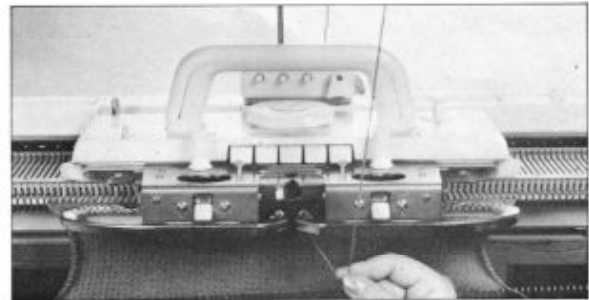

1. Take the yarn out of the YARN FEEDER "A".



Loosen the KNOBS and remove the SINKER PLATE ASSEMBLY from the K CARRIAGE.



2. Turn over the SINKER PLATE ASSEMBLY. If the yarn has wrapped around the WHEEL BRUSH, remove it from the BRUSH.

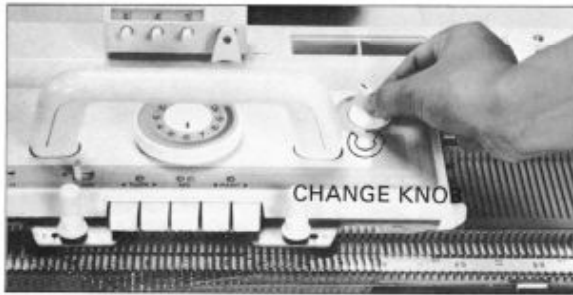

3. Set the CHANGE KNOB to position CR. This will release the K CARRIAGE.

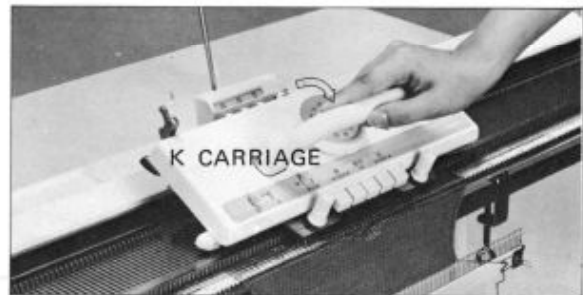

Lift the K CARRIAGE up toward you to remove it.

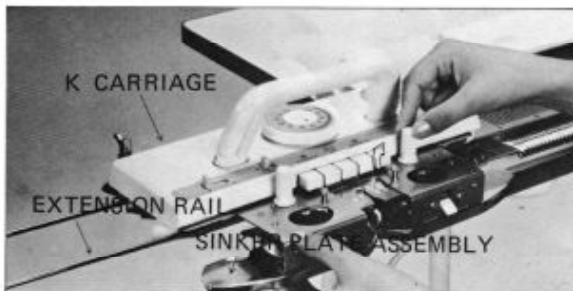

4. Place the K CARRIAGE on the EXTENSION RAIL and set the SINKER PLATE ASSEMBLY on the K carriage.



Return the CHANGE KNOB to position N-L.

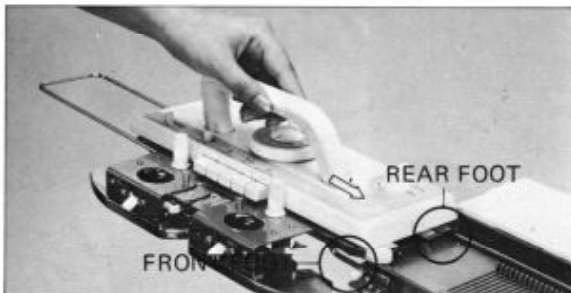

5. Make certain the K CARRIAGE is set on the NEEDLE BED correctly.

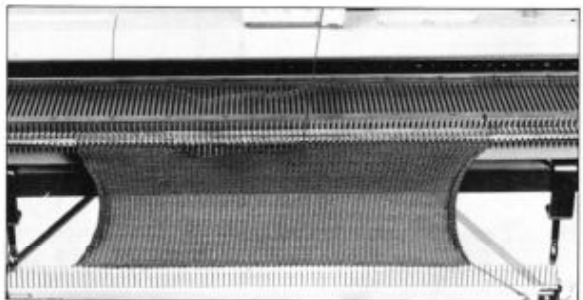

6. Unravel a row of knitting.

- 1). Using a TRANSFER TOOL transfer each stitch on the stem of a needle to the hook of the needle so that the stitches will not drop off. (This method is illustrated in the following four (4) steps.)

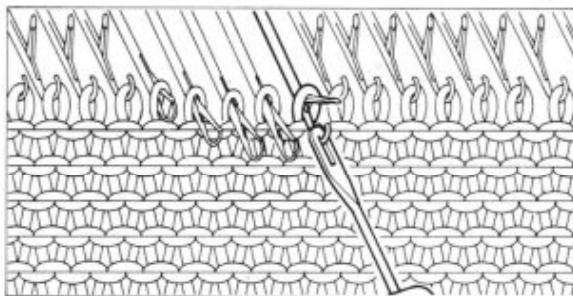

2). Place the EYE of the TRANSFER TOOL onto the hook of the needle.

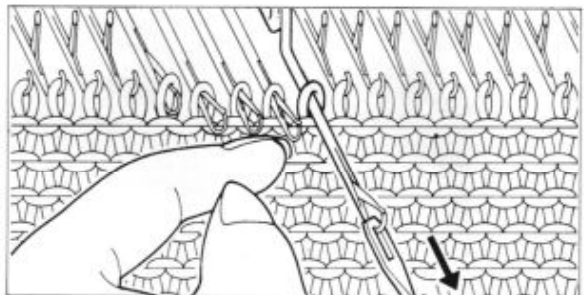

3). Hold the TRANSFER TOOL parallel with the needle and pull it toward you.

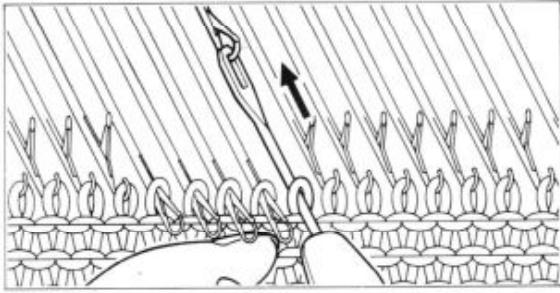

- 4). Push the **TRANSFER TOOL** toward the machine until the stitch is on the transfer tool.

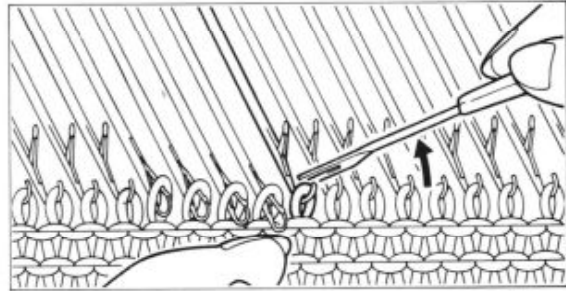

- 5). Transfer the stitch on the **TRANSFER TOOL** to the **HOOK** of the needle.

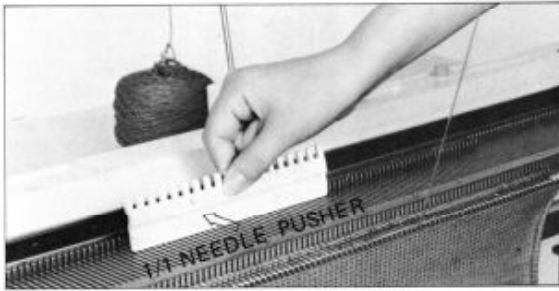

- 6). After transferring each stitch to the hook of a needle, bring back all the needles to position B by using the **1/1 NEEDLE PUSHER**.

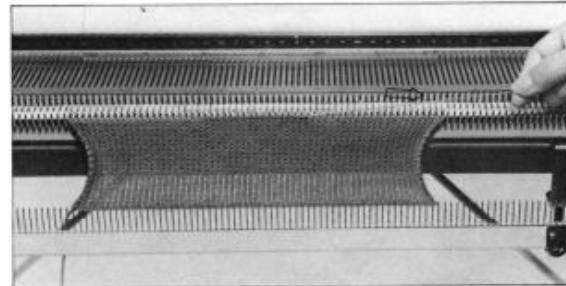

7. Unravelling a row of the knitting.  
1). Hold the yarn parallel with **GATE PEGS**.

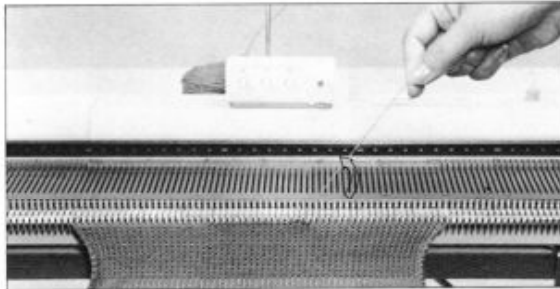

- 2). Pull the yarn slightly sideways and up to unravel the knitting.  
The stitches will come off the needles and the stitches from the row below will slip onto the needle.

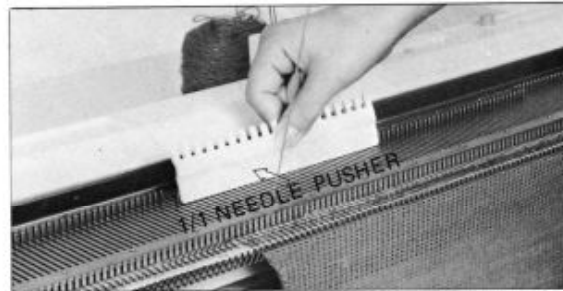

- 3). After unravelling the knitting, make sure that the stitches are in the hooks of the needles. Using the **1/1 NEEDLE PUSHER**, return the needles to position B.



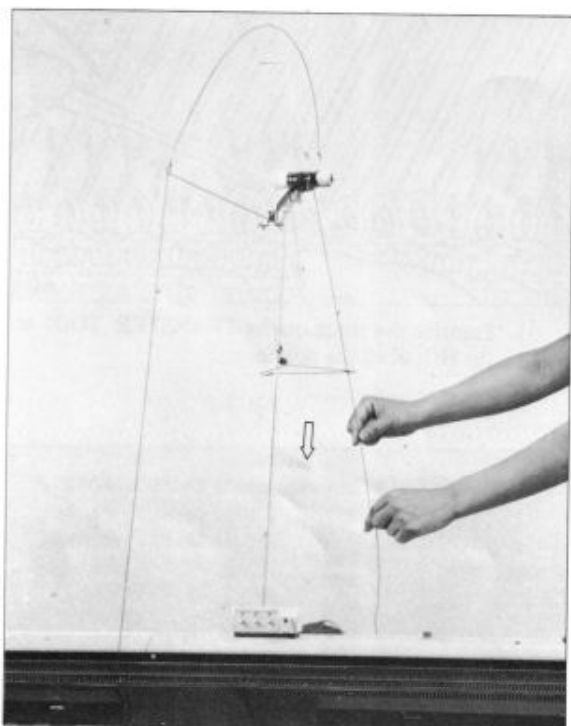

4). Pull the unravelled yarn down from behind the REAR YARN GUIDE to take up the slack. When unravelling several rows of knitting, repeat steps 1) - 4). Unravel the knitting as the yarn comes toward K CARRIAGE side.

8. Start knitting again.

1). If the yarn is now on the opposite side of the knitting from the K CARRIAGE, you may move the K CARRIAGE across the needles without knitting by pressing both "PART" buttons and setting the H.C.L. to H. Make certain that all needles are in position B before going across with the K CARRIAGE.

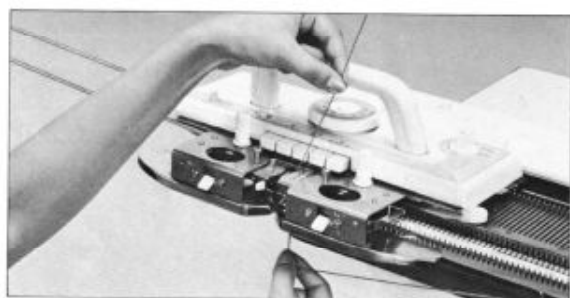

2). Insert the unravelled yarn into the YARN FEEDER "A".



3). Operate the K CARRIAGE pulling the yarn up slightly to remove any slack.

# LESSON 2

## 5. BASIC OPERATION PRACTICE II (PATTERN KNITTING)

### TUCK STITCH PATTERNS

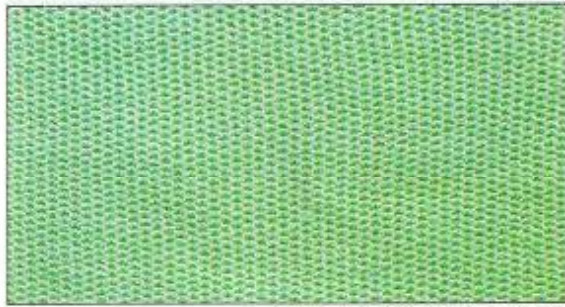

Card No. 1G, Tension No. 6



Card No. 6G, Tension No. 6



Card No. 2G, Tension No. 6

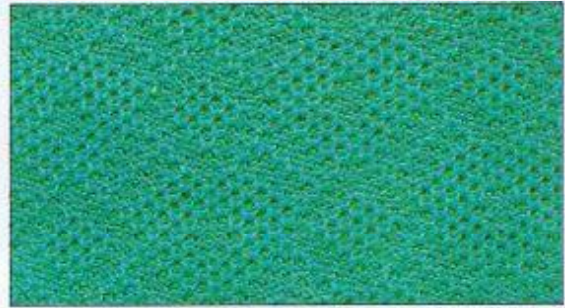

Card No. 7G, Tension No. 6



Card No. 4G, Tension No. 6



Card No. 8G, Tension No. 6

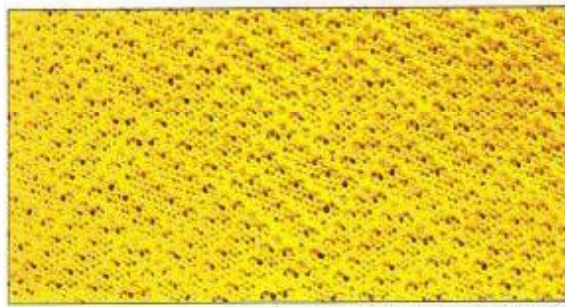

Card No. 5G, Tension No. 6

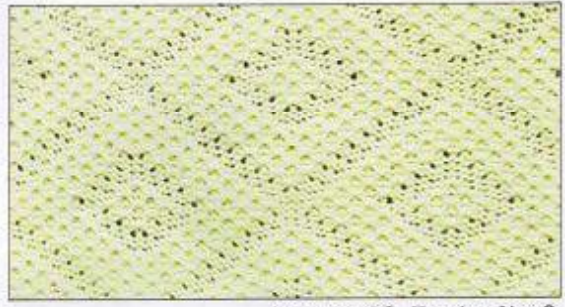

Card No. 9G, Tension No. 6



Card No. 10G, Tension No. 6



Card No. 13G, Tension No. 6

### TWO COLOR TUCK STITCH PATTERNS

\*Change the yarn in the Yarn feeder "A" every two rows.

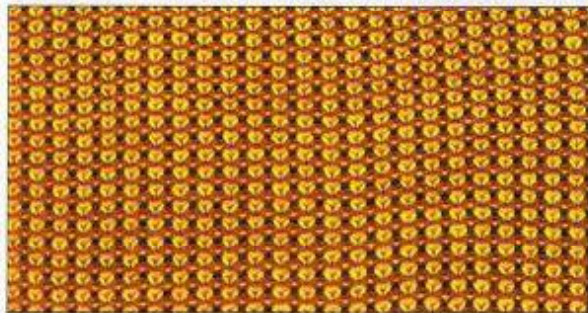

Card No. 2G, Tension No. 6



Card No. 6G, Tension No. 6



Card No. 6G, Tension No. 6



Card No. 8G, Tension No. 6

### SKIP STITCH PATTERNS



Card No. 4G, Tension No. 6



Card No. 5G, Tension No. 6



Card No. 6G, Tension No. 6



Card No. 8G, Tension No. 6



Card No. 7G, Tension No. 6



Card No. 9G, Tension No. 6

### TWO COLOR SKIP STITCH PATTERNS

\*Change the yarn in the Yarn feeder "A" every two rows.



Card No. 5G, Tension No. 6



Card No. 7G, Tension No. 6

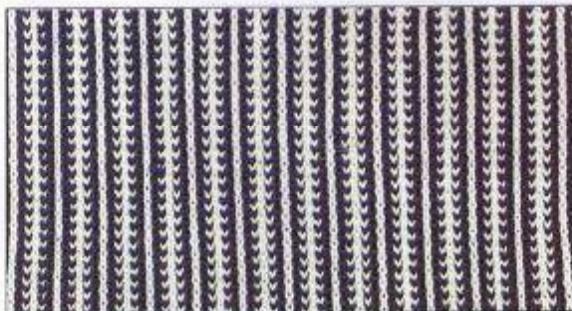

Card No. 6G, Tension No. 6

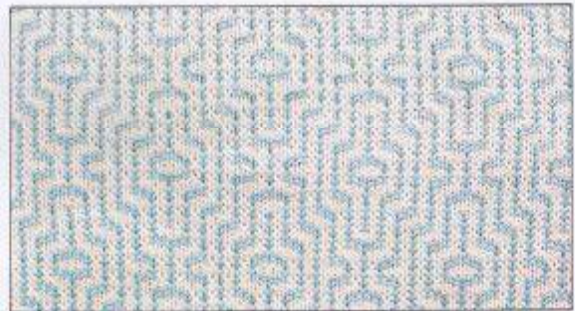

Card No. 9G, Tension No. 6

FAIR-ISLE PATTERNS



Card No. 1G, Tension No. 5



Card No. 6G, Tension No. 5



Card No. 3G, Tension No. 5



Card No. 7G, Tension No. 5



Card No. 4G, Tension No. 5



Card No. 8G, Tension No. 5



Card No. 5G, Tension No. 5



Card No. 9G, Tension No. 5

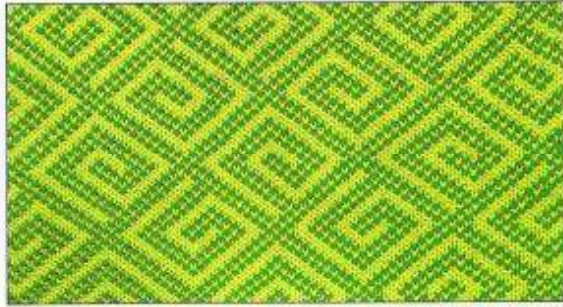

Card No. 10G, Tension No. 5

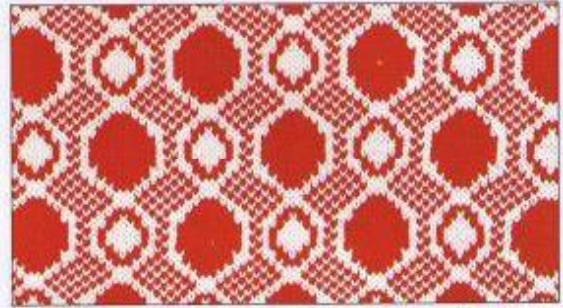

Card No. 14G, Tension No. 5



Card No. 11G, Tension No. 5



Card No. 15G, Tension No. 5



Card No. 12G, Tension No. 5



Card No. 16G, Tension No. 5



Card No. 13G, Tension No. 5



Card No. 17G, Tension No. 5

**FAIR-ISLE MOTIF**

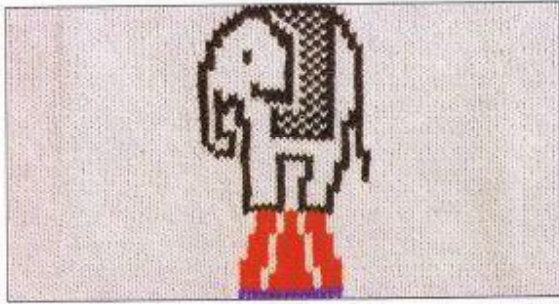

Card No. 18G, Tension No. 5



Card No. 19G, Tension No. 5

**WEAVING PATTERNS**



Card No. 1G, Tension No. 6



Card No. 4G, Tension No. 6

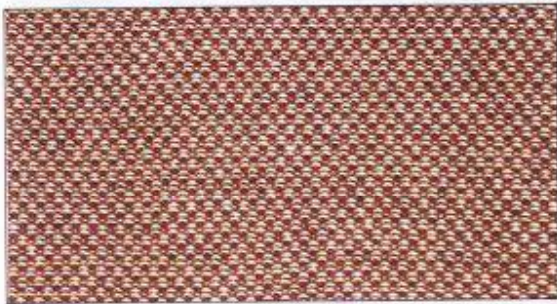

Card No. 2G, Tension No. 6



Card No. 5G, Tension No. 6



Card No. 3G, Tension No. 6



Card No. 6G, Tension No. 6



Card No. 7G, Tension No. 6

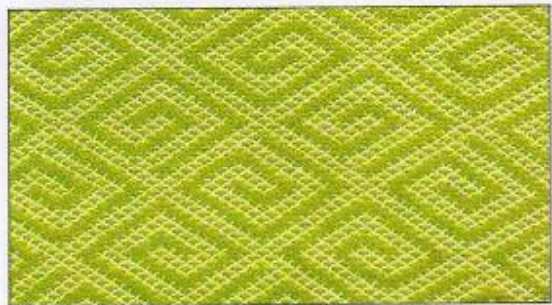

Card No. 10G, Tension No. 6



Card No. 9G, Tension No. 6



Card No. 13G, Tension No. 6

#### LACE PATTERNS

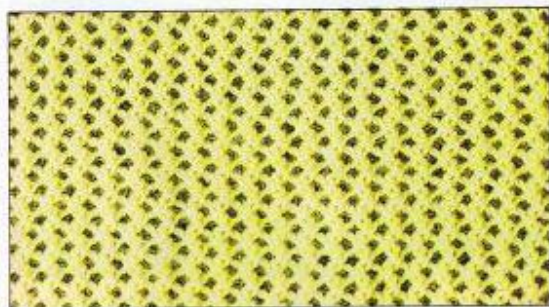

Card No. 20G, Tension No. 5

#### FINE-LACE PATTERNS



Card No. 20G, Tension No. 6

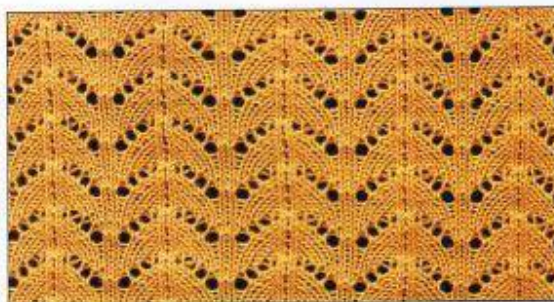

Card No. 21G, Tension No. 5

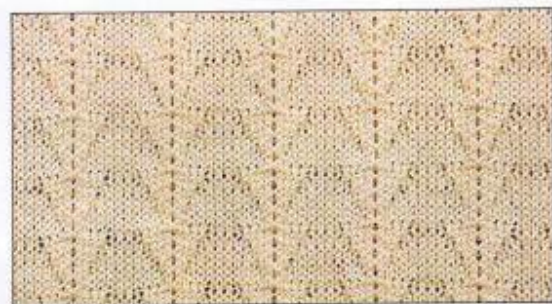

Card No. 21G, Tension No. 6





Card No. 22G, Tension No. 5

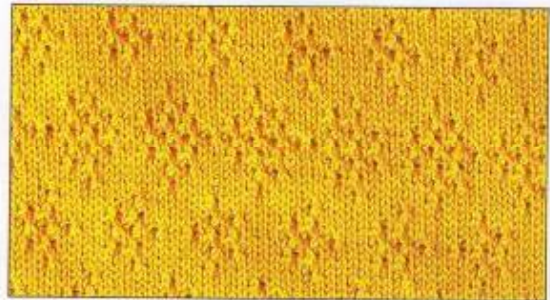

Card No. 22G, Tension No. 6



Card No. 23G, Tension No. 5



Card No. 23G, Tension No. 6



Card No. 24G, Tension No. 5



Card No. 24G, Tension No. 6



Card No. 25G, Tension No. 5



Card No. 25G, Tension No. 6

## 5-1. PUNCH CARDS

There are 25 different Punch Cards included as accessories. Using these Punch cards, it is possible to knit different fancy stitch patterns easily.

Following patterns are knitted by using these 25 Punch cards.

Pattern	Recommended Punch Card No.																								
	1G	2G	3G	4G	5G	6G	7G	8G	9G	10G	11G	12G	13G	14G	15G	16G	17G	18G	19G	20G	21G	22G	23G	24G	25G
Tuck stitch pattern	○	○		○	○	○	○	○	○	○		○													
Two color Tuck stitch pattern		○	○		○	○	○	○	○																
Skip Stitch pattern				○	○	○	○	○	○			○													
Two color Skip stitch pattern					○	○	○	○	○																
Fair-isle pattern	○	○	○	○	○	○	○	○	○	○	○	○	○	○	○	○	○	○	○						
Weaving pattern	○	○	○	○	○	○	○		○	○		○													
Lace pattern																				○	○	○	○	○	○
Fine-lace pattern																				○	○	○	○	○	○

You can knit each of the various patterns marked "○" with one Punch card.  
The Punch cards No. 20G – 25G are special Punch cards for Lace pattern and Fine-lace pattern knitting.

## 5-2. RELATION BETWEEN THE PUNCH CARD AND THE NEEDLES

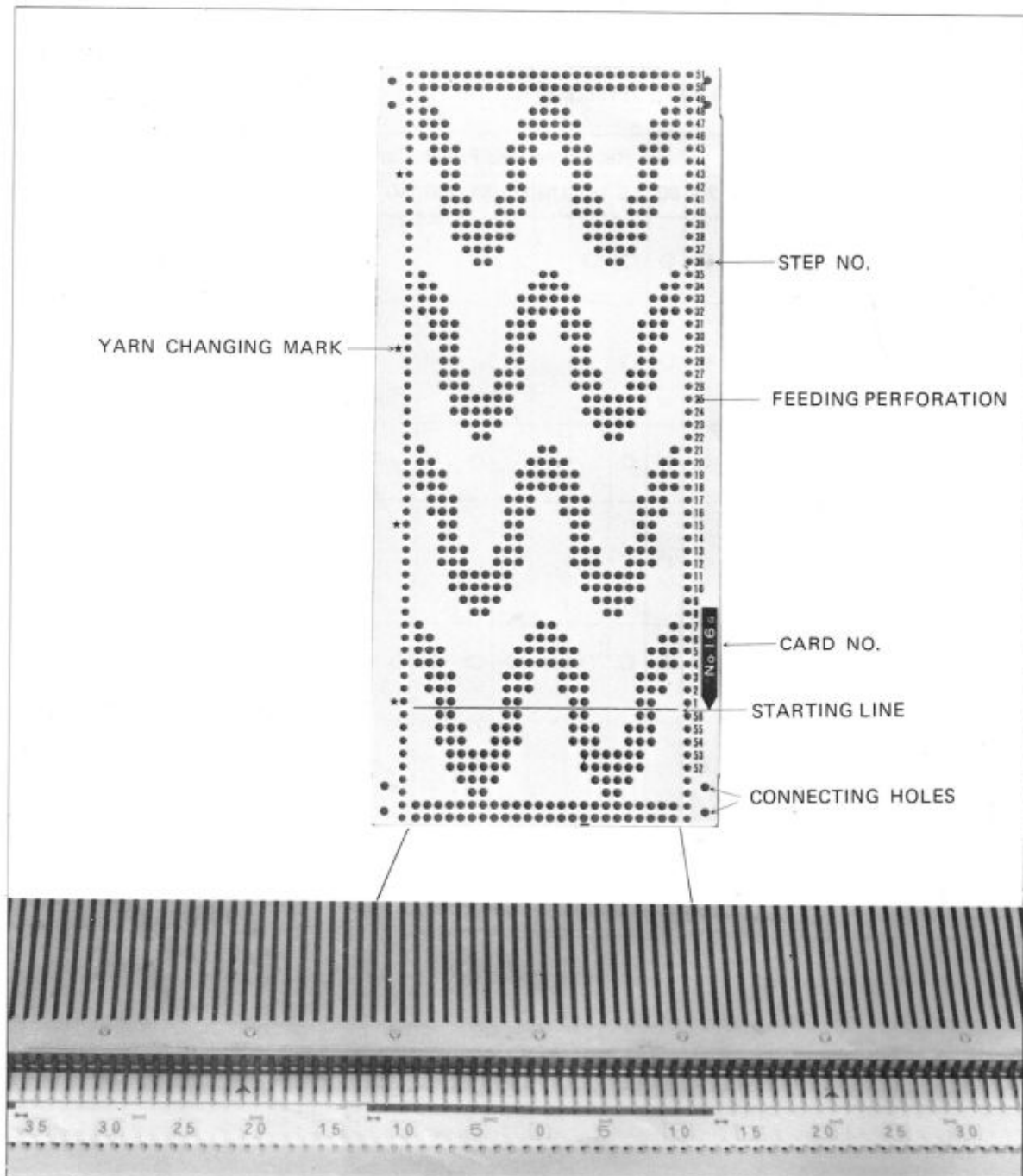

Each perforated line of the punch card controls one needle group, namely 24 needles.

(12 needles on either side of the center mark "0" make one pattern.)

Each needle group (24 needles) marked with Red lines on the NEEDLE POSITION INDICATOR, makes one pattern. The needles corresponding to the perforations made on the punch card can be selected by moving the K CARRIAGE across the needles in working position.

### 5-3. PREPARATION FOR PATTERN KNITTING

#### 5-14. Setting the Punch card.

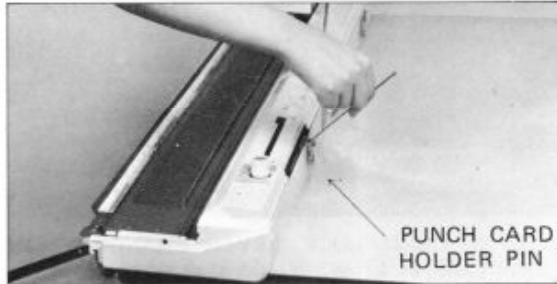

1. Insert the PUNCH CARD HOLDER PIN in the hole behind the slit.

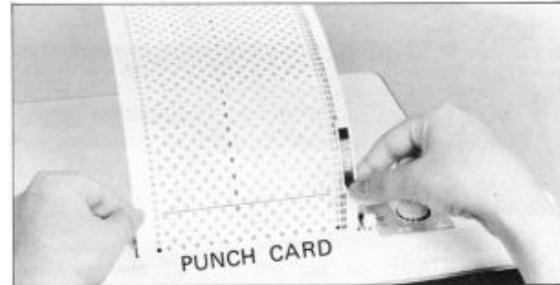

2. Insert the PUNCH CARD into the slit in a straight line with the numbers facing you. Please be careful that when inserting the PUNCH CARD, it is straight.

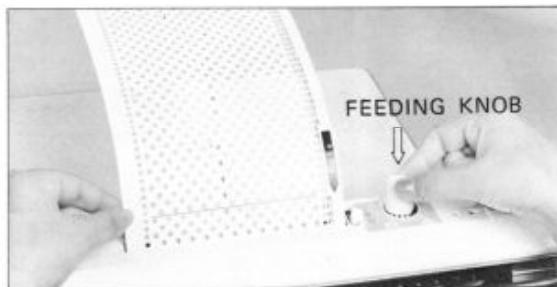

3. Make sure that the starting line is parallel to the panel. Press down the FEEDING KNOB and turn to left to feed the Punch card.

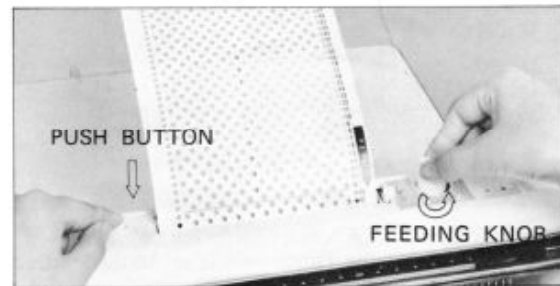

4. It is easier to turn the FEEDING KNOB by pressing down the PUSH BUTTON at the same time.

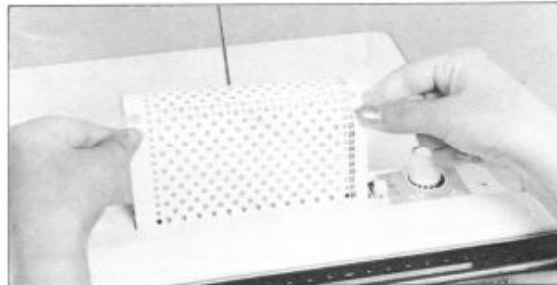

5. The card ends must be overlapped and clipped together with the PLASTIC SNAPS provided in the accessory box.

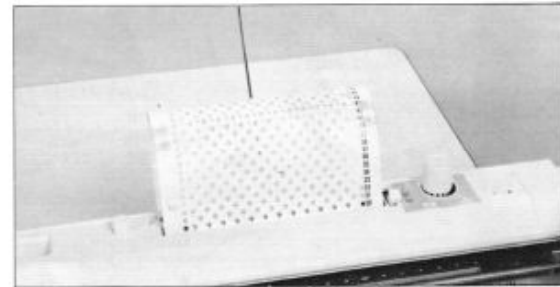

When clipped together, the numbers on the card must continue in the right sequence.

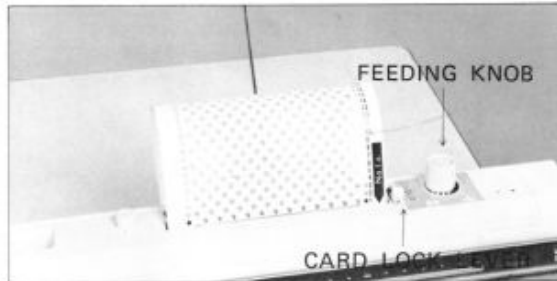

6. Turn the FEEDING KNOB and set to the starting line (No. 1). Set the CARD LOCK LEVER to the "●" mark.

#### The CARD LOCK LEVER;

- : The punch card is locked even if the carriage is moved.
- ▼ : The punch card is rotated by movement of the carriage.
- ▽ : Intermittent card feeding position; the punch card is rotated only when the carriage moves from right to left. This position is used for making double length patterns.

**5-3-2. Preparation for pattern knitting**

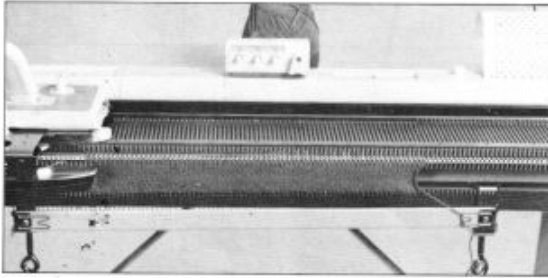

1. Knit several rows of plain knitting and place the K CARRIAGE on the left side of the machine.

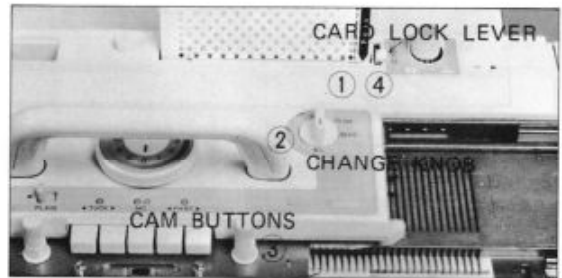

2. Set the CARD LOCK LEVER, CHANGE KNOB and CAM BUTTONS in order as shown in the figure.



3. Set the CARD LOCK LEVER to the "●" mark. Make sure that the Punch card is set to the starting line. (No. 1).



4. Set the CHANGE KNOB to the "KC" position. For Lace pattern knitting the CHANGE KNOB is to be set to the "N-L" position.

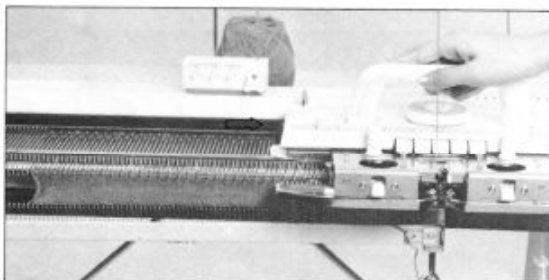

5. Move the K CARRIAGE from left to right. The position B needles are selected to position B and D by moving the K CARRIAGE.

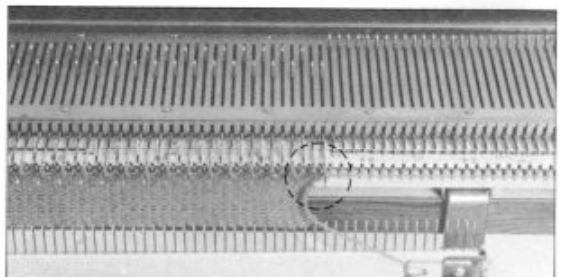

If the end needle is not selected, bring forward the end needle into position D by hand before you start knitting.



6. Push the CAM BUTTONS according to the pattern you are going to knit.



7. Set the CARD LOCK LEVER to the "▼" mark. Then start pattern knitting.

**5-4. TUCK STITCH PATTERNS.  
SKIP STITCH PATTERNS.**

1. Set the Punch Card and prepare for pattern knitting.
2. Push the CAM BUTTONS according to the pattern you are going to knit.

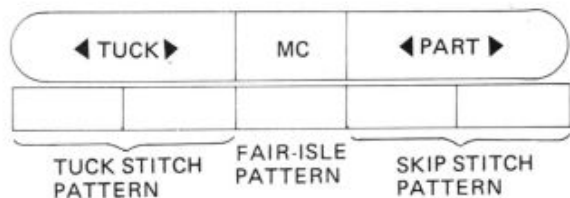

Tuck stitch patterns ....  
Push both "TUCK" buttons at the same time.



Skip stitch patterns ....  
Push both "PART" buttons at the same time.

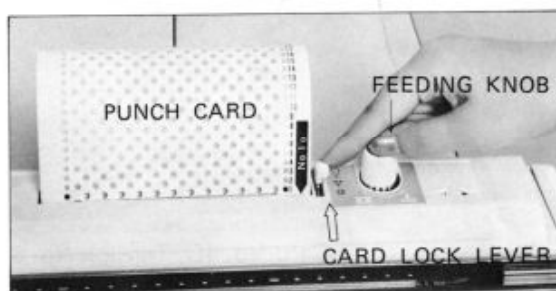

3. Set the CARD LOCK LEVER to "▼" mark.



4. Operate the K CARRIAGE from right to left. The needles are selected automatically. Continue knitting. Hang the CLAW WEIGHTS onto the CAST-ON COMB (as shown in the figure) to avoid a dropped stitch. The CLAW WEIGHTS should be repositioned at the top edges of the knitting at regular intervals.

### Tuck Stitch Patterns

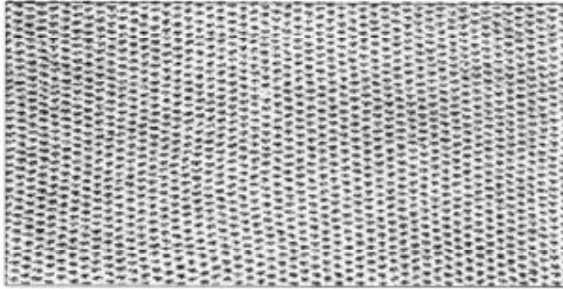

Card No. 1G, Tension No. 6

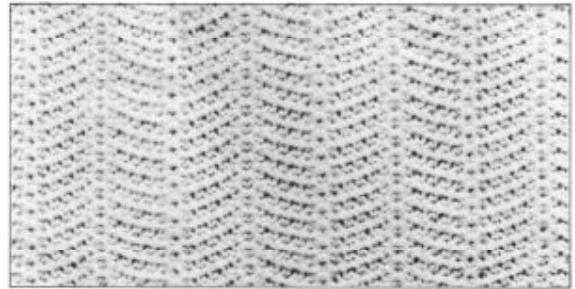

Card No. 6G, Tension No. 6

### Skip Stitch Patterns

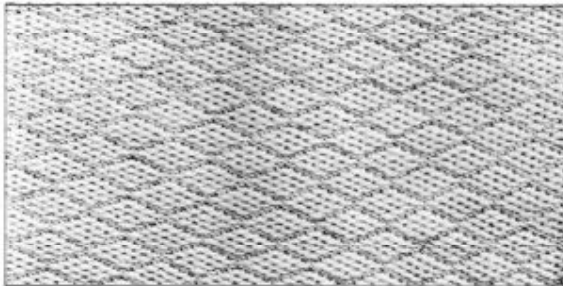

Card No. 4G, Tension No. 6

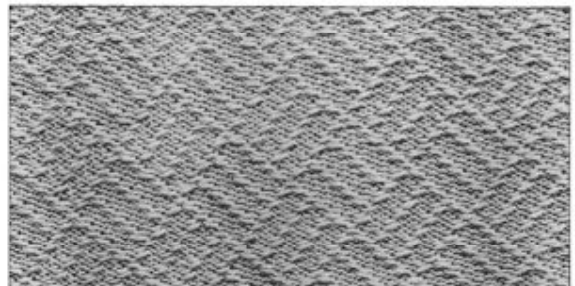

Card No. 5G, Tension No. 6

## 5-5. AFTER FINISHING PATTERN KNITTING

When the starting line (No. 1) of the PUNCH CARD comes to the slit, one pattern is completed. Return to plain knitting as instructed below after finishing any pattern stitches.



1. By turning the CHANGE KNOB from "KC" or "SM" to "N-L" position, the CAM BUTTONS will be restored automatically.



2. When the CHANGE KNOB is set to "NL" position, restore the CAM BUTTONS by pushing the CAM BUTTON RELEASE LEVER.



For weaving patterns, set the WEAVING PATTERN LEVER to position N.

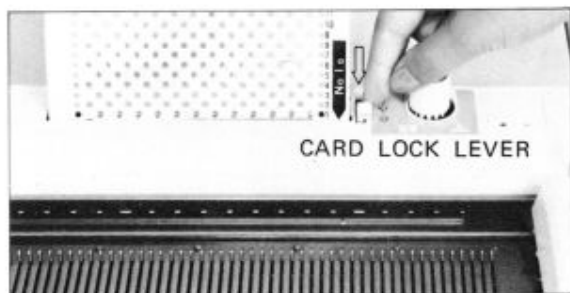

3. Return the CARD LOCK LEVER to the "●" mark. When you knit Fair-isle patterns or Weaving patterns, take the second color yarn out of the YARN FEEDER and clip it under the YARN CLIP. Make sure that the main yarn is in the YARN FEEDER "A". Then do plain knitting.

## 5-6. TWO COLOR TUCK STITCH PATTERNS TWO COLOR SKIP STITCH PATTERNS

Operation is the same as Tuck stitch patterns and/or Skip stitch patterns.

1. Set the PUNCH CARD and prepare for pattern knitting. (See page 43, 44)
2. Push both CAM BUTTONS according to the pattern you are going to knit.

Two color Tuck stitch patterns ....

Push both "TUCK" buttons at the same time.

Two color Skip stitch patterns ....

Push both "PART" buttons at the same time.

3. Set the CARD LOCK LEVER to the "▼" mark.

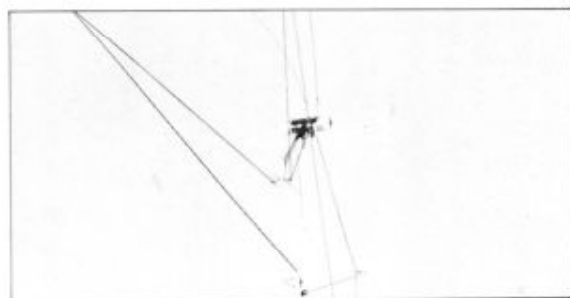

5. Thread the second color yarn into the YARN TENSION UNIT and clip it under the YARN CLIP

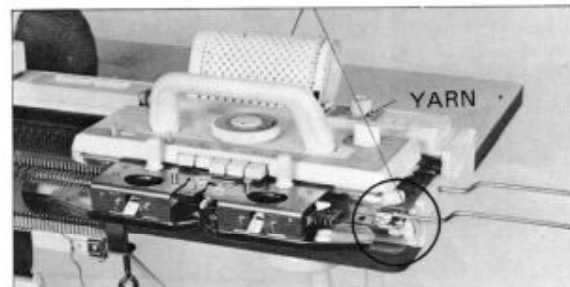

7. Hook the yarn taken from the YARN FEEDER "A" on the edge of the machine to hold it.

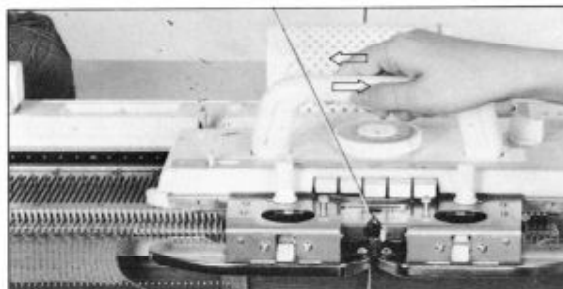

4. Operate the K CARRIAGE and knit two rows.

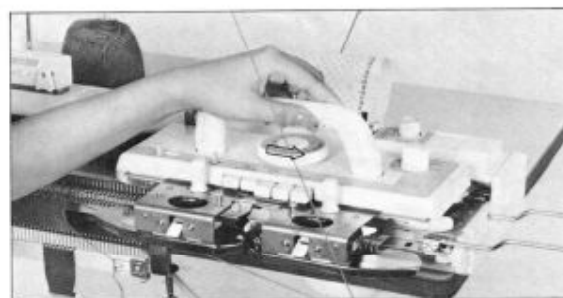

6. Change the yarn in the YARN FEEDER "A" to the second color yarn for two color patterns. K CARRIAGE is on the right side of the machine. Pull the yarn in the YARN FEEDER "A" out. It is easier to remove the yarn by moving the K CARRIAGE to the right.





8. Then, thread the second color yarn which was clipped under the YARN CLIP into the YARN FEEDER "A". Close the YARN FEEDER LEVER.

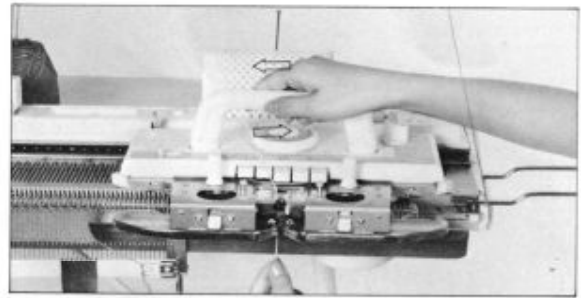

9. Knit two rows holding the end of the second color yarn under the YARN FEEDER with your left hand. (Keep your left hand at the right edge of the knitting.)

Change the yarn in the YARN FEEDER "A" every two rows in the same way. You can enjoy two color Tuck stitch patterns and/or two color Skip stitch patterns.

#### Two Color Tuck Stitch Patterns

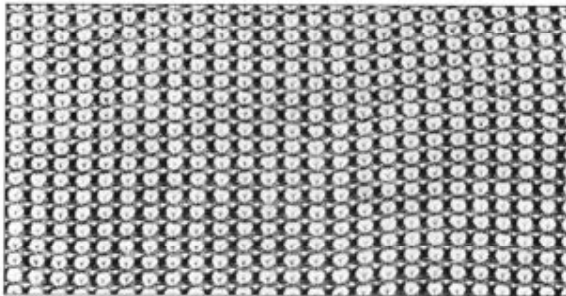

Card No. 2G, Tension No. 6

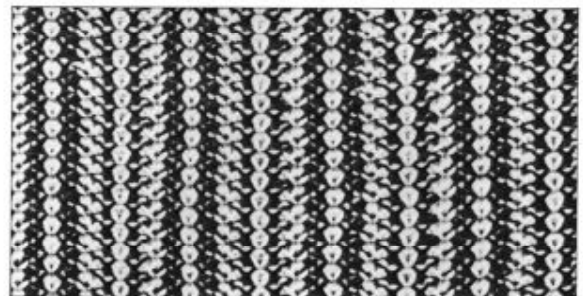

Card No. 6G, Tension No. 6

#### Two Color Skip Stitch Patterns

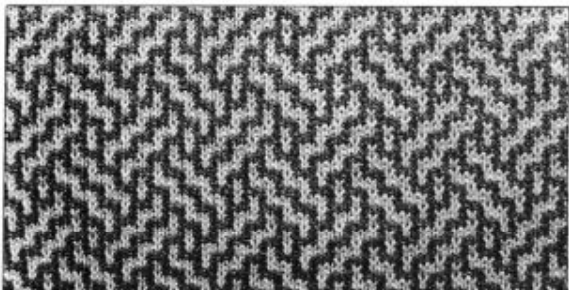

Card No. 5G, Tension No. 6

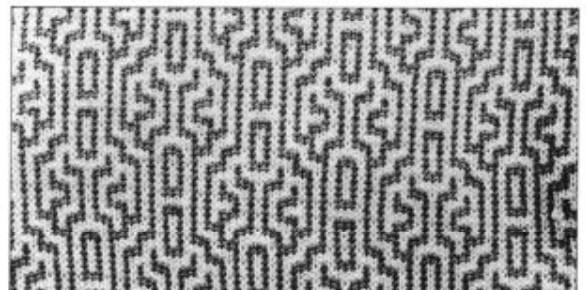

Card No. 7G, Tension No. 6

## 5-7. FAIR-ISLE PATTERNS

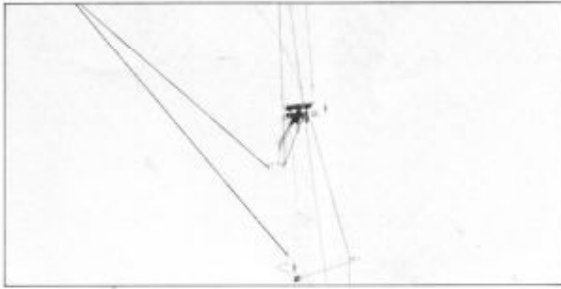

1. Thread the second color yarn into the YARN TENSION UNIT and clip the yarn under the YARN CLIP.

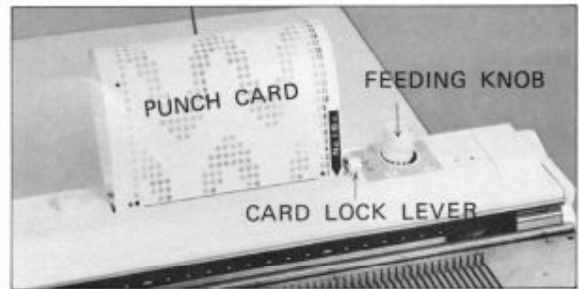

2. Set the Punch Card and prepare for pattern knitting. (See page 43, 44)



3. Push the "MC" button, and set the CARD LOCK LEVER to the "▼" mark.



4. Thread the second color yarn which is clipped under the YARN CLIP into YARN FEEDER "B" without opening the YARN FEEDER LEVER. Hold the yarn under the YARN FEEDER with your left hand. (Keep your left hand at the right edge of the knitting.)

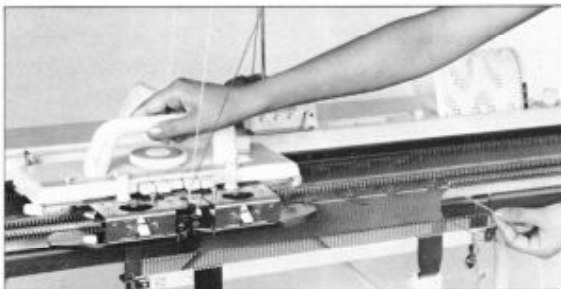

5. Continuing to operate the K CARRIAGE, you can enjoy Fair-isle patterns.

When you use Punch cards No. 11G, 12G, 14G, 16G, 18G and 19G, change the second color yarn in the YARN FEEDER "B" to the third color yarn when the star mark "★" on the left side of the PUNCH CARD comes to the slit. Then you can enjoy multi-color Fair-isle patterns. Pull the second color yarn out of the YARN TENSION UNIT and thread the third yarn into it. Then thread the third color yarn into the YARN FEEDER "B"



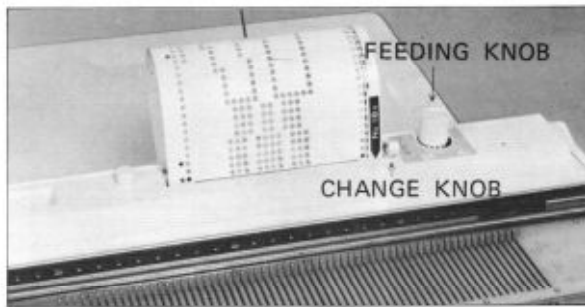

3. Set the PUNCH CARD to the starting line (No. 1) and the CARD LOCK LEVER to the "●" mark.

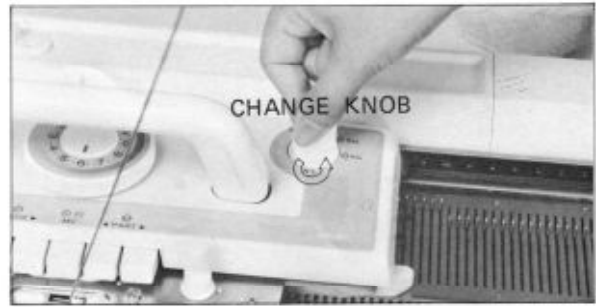

4. Set the CHANGE KNOB to the "SM" position.

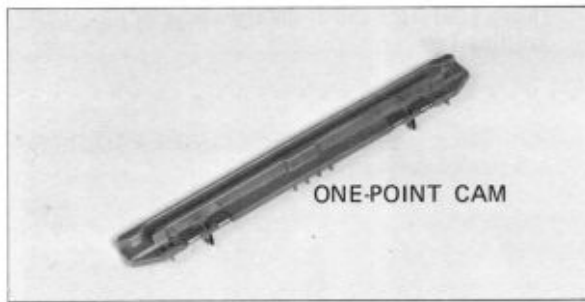

5. Take the ONE-POINT CAM out of accessory box.

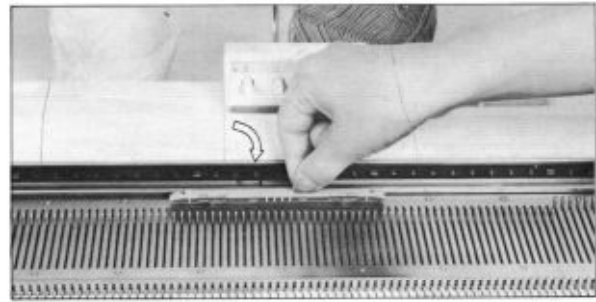

6. Set the ONE-POINT CAM on the needle bed as shown in the figure.

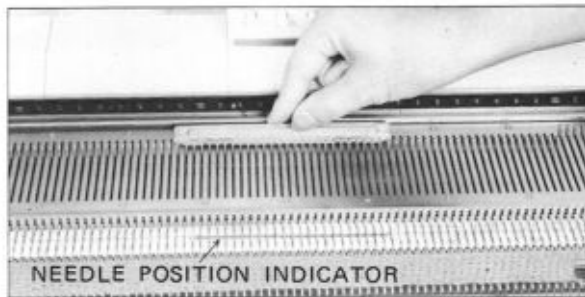

Make sure that the ONE-POINT CAM is set on the proper position which corresponds to the red line marks of the NEEDLE POSITION INDICATOR.



7. Move the K CARRIAGE from left to right.



8. The needles in position B where the ONE-POINT CAM is set are selected to position B and D by moving the K CARRIAGE.



9. Push the "MC" button.

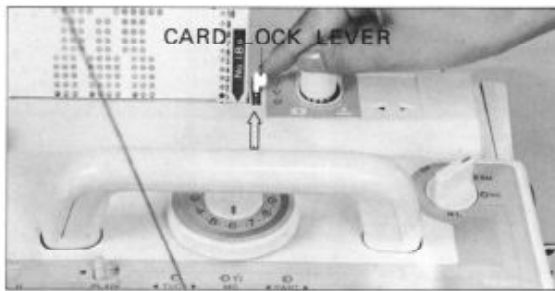

10. Set the CARD LOCK LEVER to the "▼" mark.

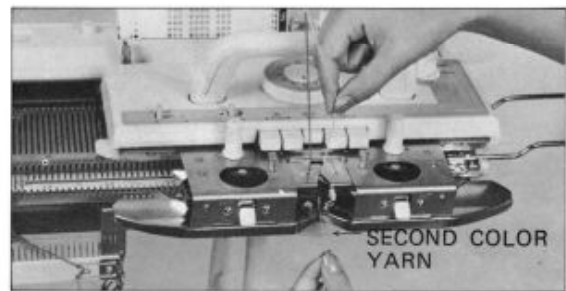

11. Thread the second color yarn which is clipped under the YARN CLIP into YARN FEEDER "B" without opening the YARN FEEDER LEVER. Hold the Yarn under the YARN FEEDER with your left hand.  
(Keep your left hand at the right edge of the knitting.)

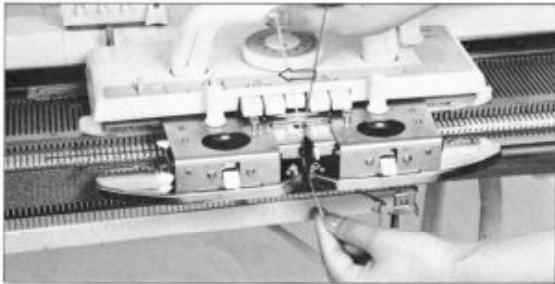

12. Knit one row and place the K CARRIAGE on the left side of the machine.

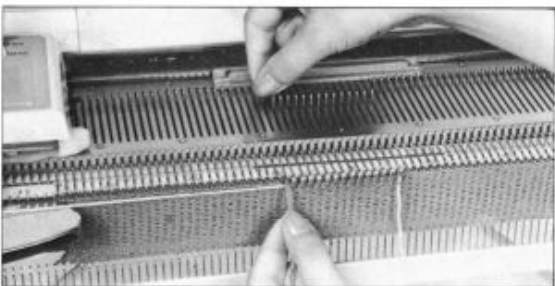

13. On the side next to the K CARRIAGE, put a separate single strand of yarn into the HOOK of the position B needle which is adjacent to the first needle selected for the pattern.

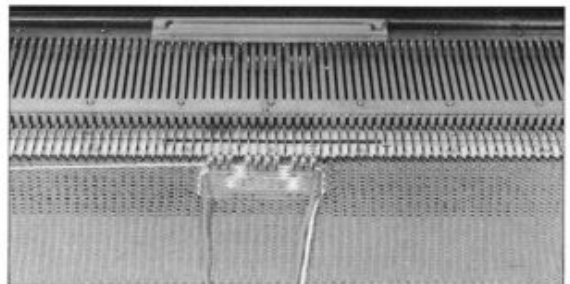

This is to stop the gap which sometimes appears between the edge of the motif and the background color.

It is better to use the same color as the main yarn for the separate yarn.

14. Move the K CARRIAGE from left to right and repeat these steps for each row.

Now, Fair-isle Motif is completed.

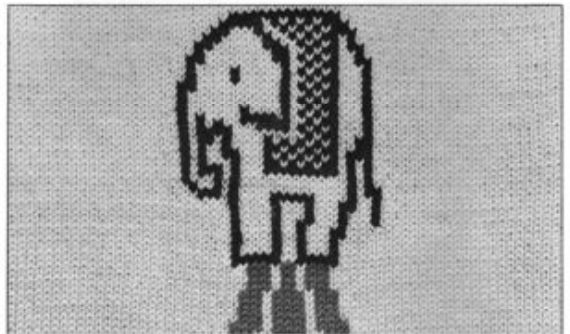

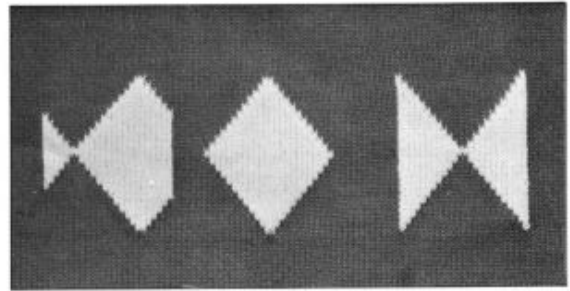
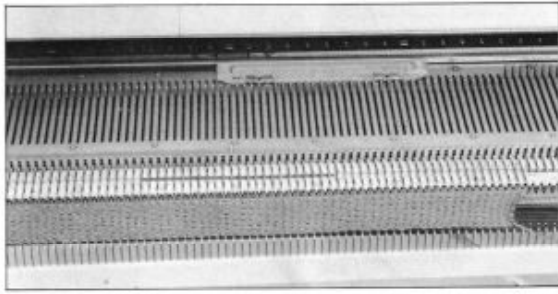

As shown in the figure, by changing the setting position of the ONE-POINT CAM, you can also enjoy unique Fair-Isle Motifs.

### 5-9. DOUBLE FAIR-ISLE MOTIF



1. Set the two ONE-POINT CAMS on the needle bed as shown in the figure.

Take a space for one pattern (24 needles) between the two ONE-POINT CAMS.

2. The operation is the same as Fair-Isle motif.

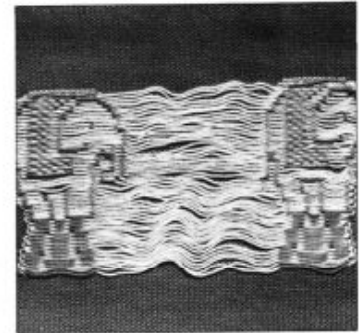
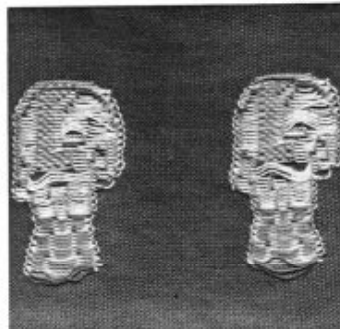

3. Place the second color yarn for each pattern at your feet.

4. Change the second color yarn whenever the K CARRIAGE moves to avoid traversing yarn at the back of the knitting.

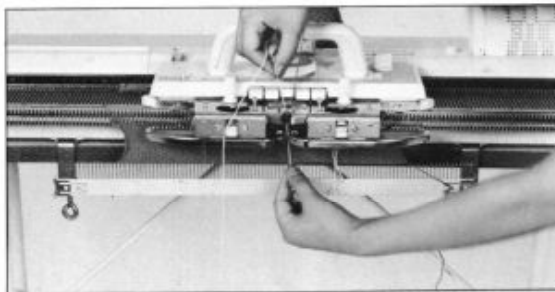

- 1). When the YARN FEEDER of K CARRIAGE comes to the center of the two patterns, change the yarn in the yarn feeder "B" to the second color yarn for the left motif.

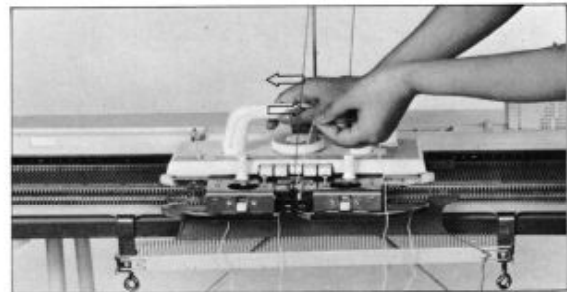

- 2). Move the K CARRIAGE to left and come back to the center of the two patterns.

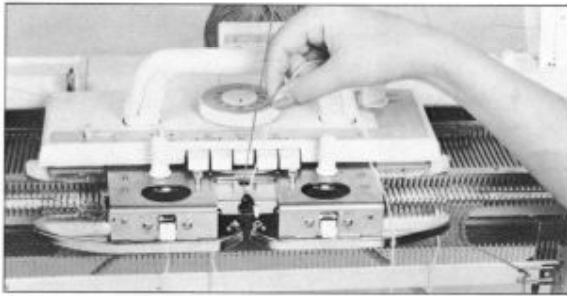

3). Change the yarn in the yarn feeder "B" to the second color yarn for the right motif.

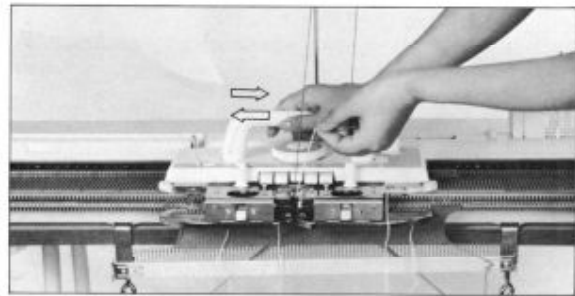

4). Move the K CARRIAGE to right and come back to the center of the two patterns.

5). Repeat these steps each row.

Then, you have made a Double Fair-isle motif.

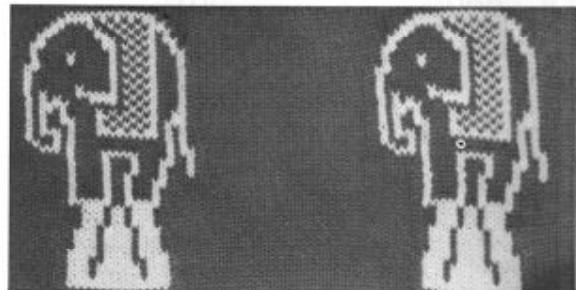

## 5-10. WEAVING PATTERNS

1. Set the Punch card and prepare for pattern knitting. (See page 43, 44)
2. Do not push the CAM BUTTONS.
3. Set the CARD LOCK LEVER to the "▼" mark.



4. Set the WEAVING PATTERN LEVER to W.T.

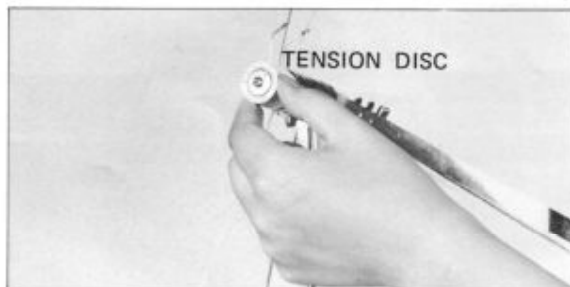

5. Thread the Weaving yarn into the YARN TENSION UNIT and clip it under the YARN CLIP. Adjust the TENSION DISC. When using a thick yarn, set the "-" mark to the "▼" mark.



6. Make sure that the Weaving yarn is in the left WEAVING YARN GUIDE.

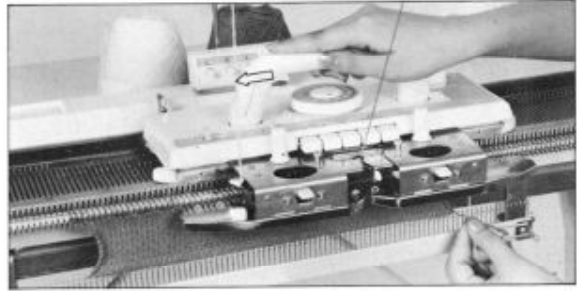

Hold the end of the Weaving yarn with your left hand. (Keep your left hand at the right edge of the knitting.) Operate the K CARRIAGE.

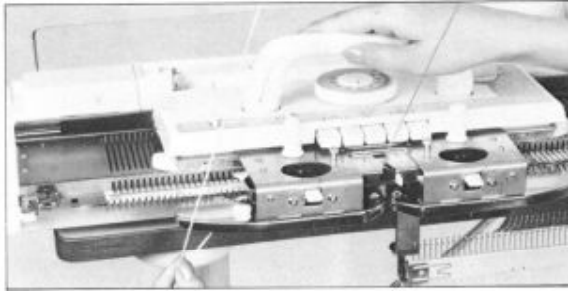

7. Remove the weaving yarn in the left WEAVING YARN GUIDE.

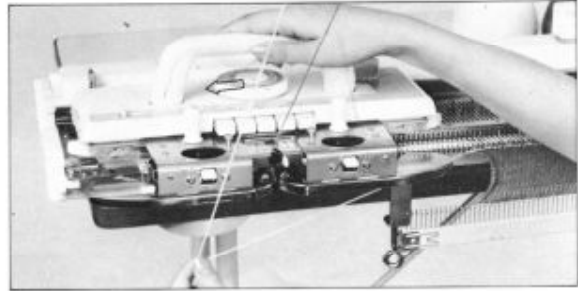

Move the K CARRIAGE slightly to the left.



8. Transfer the Weaving yarn under the K CARRIAGE to the right WEAVING YARN GUIDE.

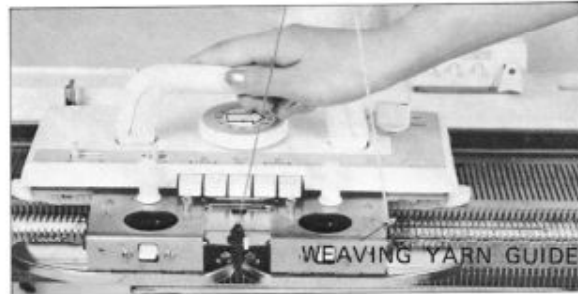

9. Move the K CARRIAGE to right making sure that the weaving yarn is in the right WEAVING YARN GUIDE.

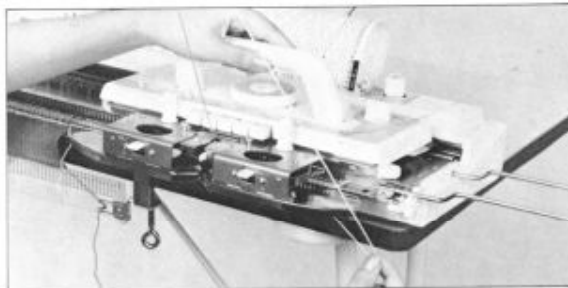

10. Remove the Weaving yarn in the right WEAVING YARN GUIDE.

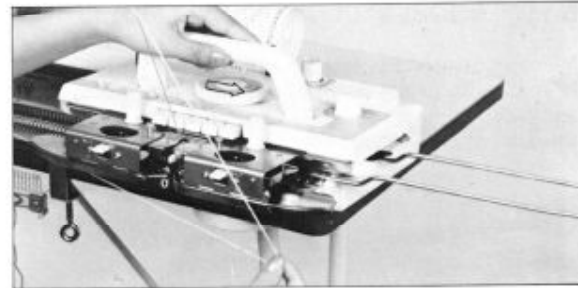

Move the K CARRIAGE slightly to the right and transfer the Weaving yarn under the K CARRIAGE and to the left WEAVING YARN GUIDE.

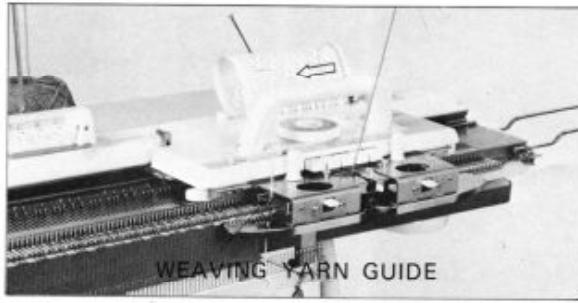

11. Move the K CARRIAGE to left making sure that the weaving yarn is in the left WEAVING YARN GUIDE.
12. Repeat the procedures from 7 to 11. Then you can enjoy Weaving patterns.

### Weaving patterns

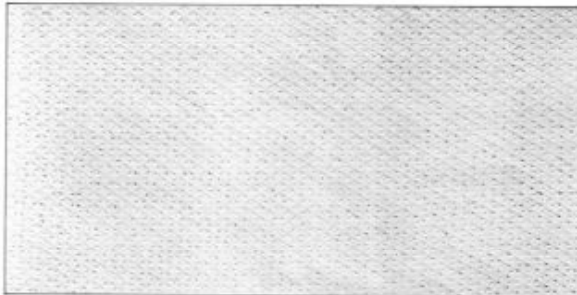

Card No. 1G, Tension No. 6

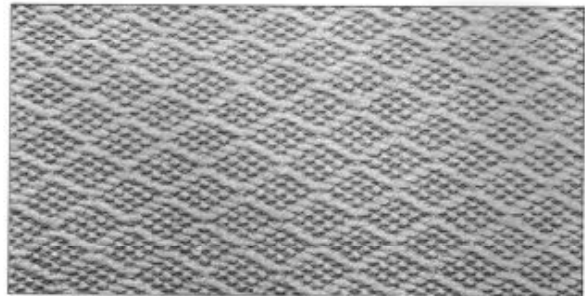

Card No. 4G, Tension No. 6



Card No. 7G, Tension No. 6

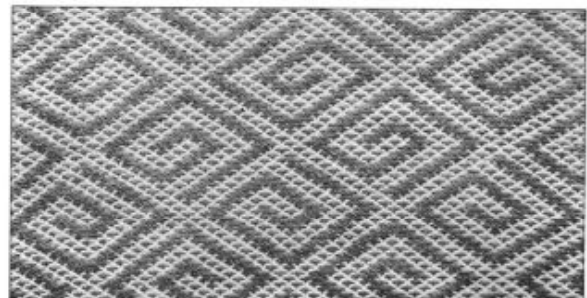

Card No. 10G, Tension No. 6

### 5-11. DOUBLE LENGTH PATTERNS

You can double the length of the pattern. This method is applicable to the Fair-isle patterns, Weaving patterns and Skip stitch patterns. (Do not apply this method to the Tuck stitch patterns and Lace patterns.)





### 5-11-1. Preparation for Double Length Patterns.

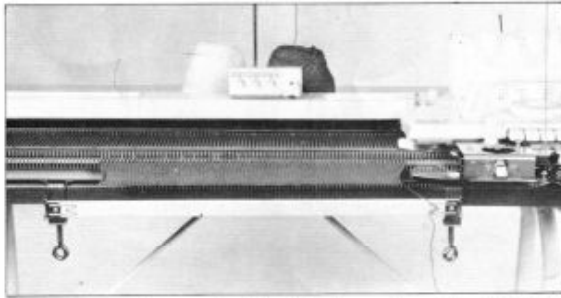

1. Knit several rows of plain knitting and put the K CARRIAGE on the right side of the machine.
2. Set the PUNCH CARD.

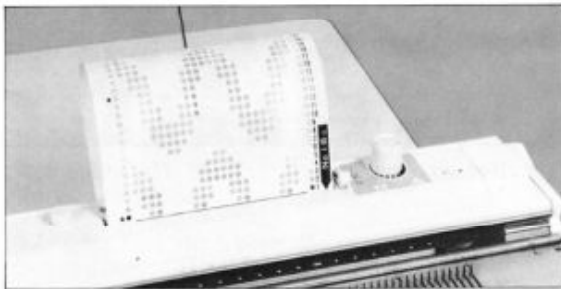

4. Set the PUNCH CARD to the starting line (No. 1) and the CARD LOCK LEVER to the "●" mark.

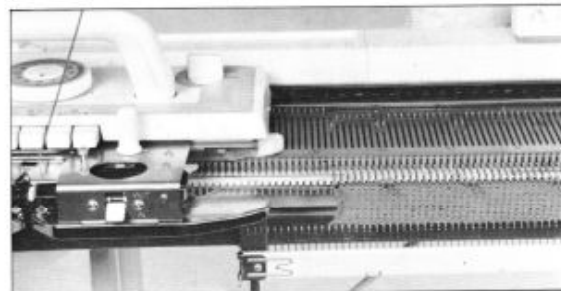

The position B needles are selected to position B and D.

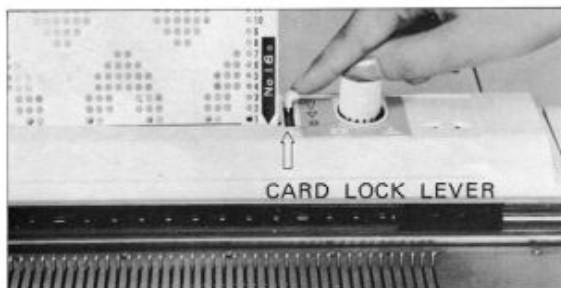

3. Set the CHANGE KNOB to position K.C.

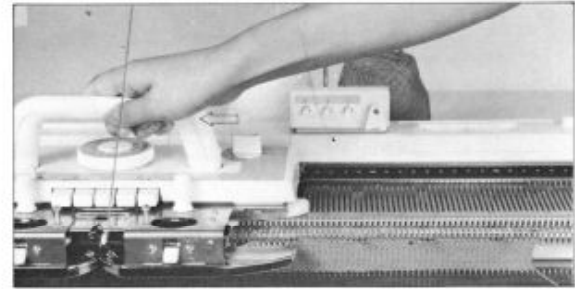

5. Move the K CARRIAGE to left.



6. Push the CAM BUTTONS or set the WEAVING PATTERN LEVERS according to the pattern you are going to knit.

7. Set the CARD LOCK LEVER to the "∇" mark.

Operation is the same as in other pattern knitting.

The PUNCH CARD is rotated only when the K CARRIAGE moves from RIGHT to LEFT.

### 5-11-2. When Knitting Normal and Double Length Patterns Mixed.

In the same way as the Double length patterns, put the K CARRIAGE on the right side of the machine and select the needles.

1. When the "★" mark of the left side of the punch card comes to the slit, change the setting of the CARD LOCK LEVER ("∇" or "▼") and continue knitting.

When you change the CARD LOCK LEVER, the K CARRIAGE is always on the left side of the machine.

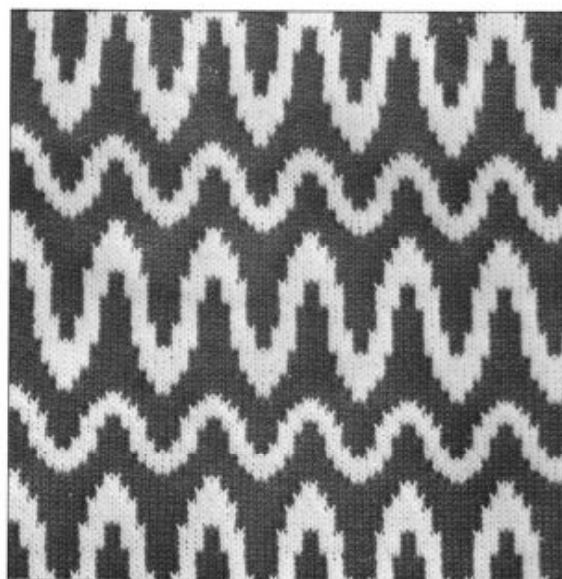
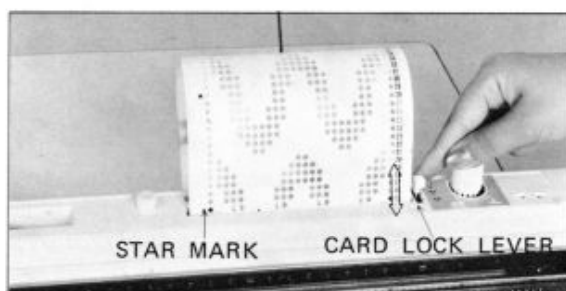

### 5-12. PLATING YARN KNITTING

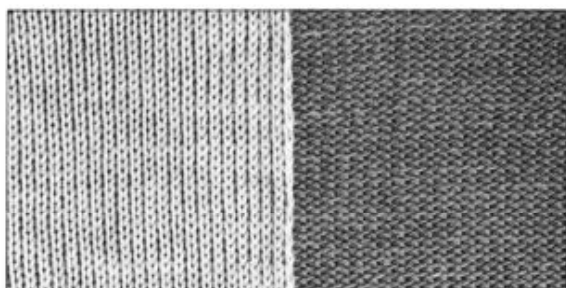

FRONT (Plain)

BACK (Purl)

With the PLATING YARN FEEDER it is possible to use two yarns to knit a reversible fabric with different colors on the front and back side.

The main yarn will appear on the front (plain) side of the fabric and plating yarn will appear on the back (purl) side of the fabric.

Suggested Tension Dial (T.D.) number is as follows.

Main Yarn	Plating Yarn	Suggested T.D. Number
Fine yarn	Fine yarn	6 ~ 7
Fine yarn	Very fine yarn	5 ~ 6
Very fine yarn	Fine yarn	5 ~ 6
Very fine yarn	Very fine yarn	4 ~ 5

**5-12-1. Preparation for Plating yarn knitting and how to knit.**

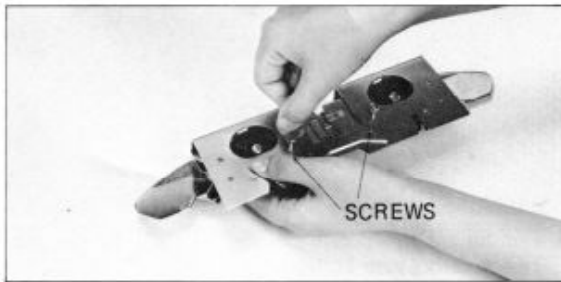

1. Change the yarn feeder to the **PLATING YARN FEEDER**, by following these four (4) steps:  
 1). Loosen the two screws and remove the **YARN FEEDER** from **Sinker plate assembly**.

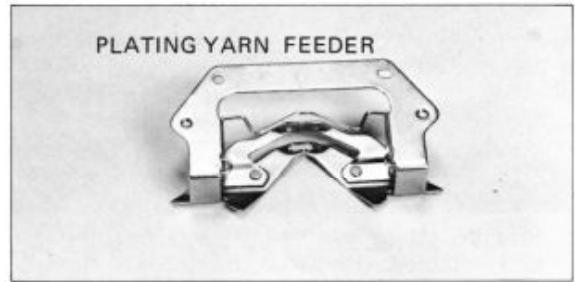

- 2). Take the **PLATING YARN FEEDER** out of the accessory box.

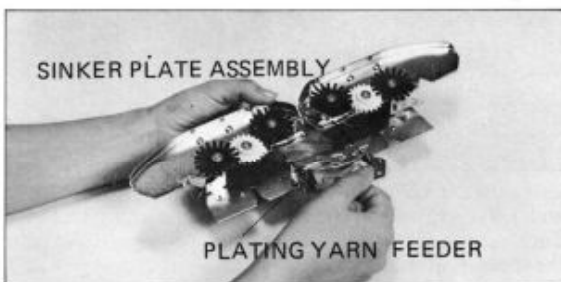

- 3). Set the **PLATING YARN FEEDER** to the **Sinker plate assembly** as shown in the figure.

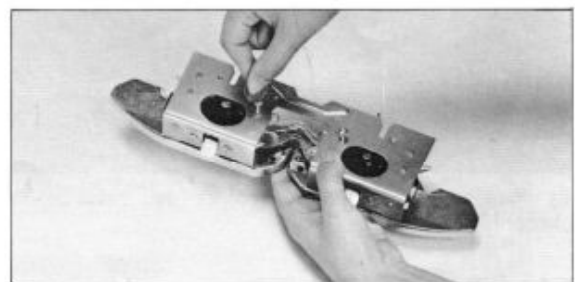

- 4). Then fasten the two screws.

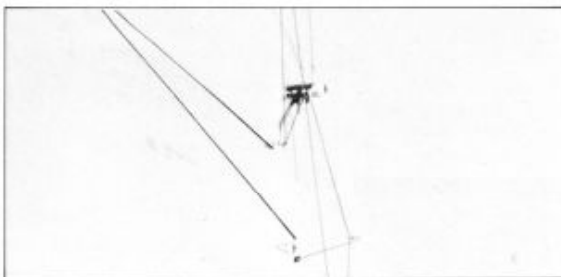

2. Thread the main and plating yarns into the **YARN TENSION UNIT**, and clip them under the yarn clip.

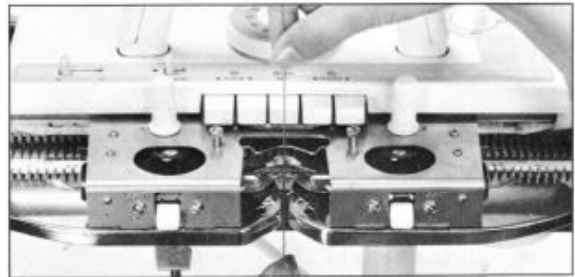

3. Thread the main yarn into the main yarn feeder. Knit several rows of plain knitting and place the **K CARRIAGE** on the right side of the machine.

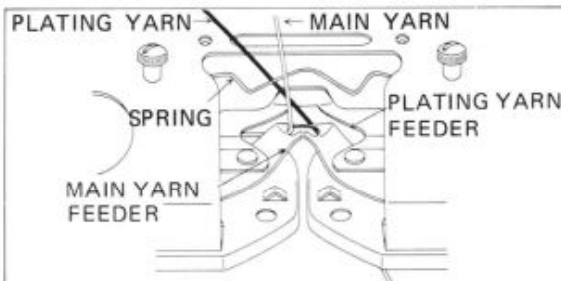

4. Thread the plating yarn into the plating yarn feeder. Pass the plating yarn behind the yarn feeder spring and thread it into the plating yarn feeder.

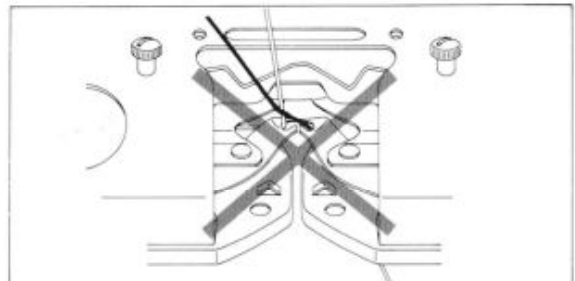

Make sure that the yarns do not cross each other.

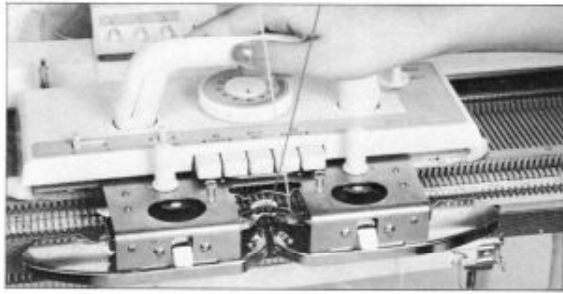

5. Hold the plating yarn under the yarn feeder with your left hand. (Keep your left hand at the right side of the knitting.)

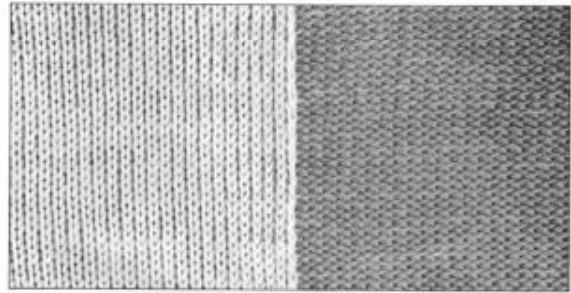

6. Continuing to operate the K CARRIAGE, you can enjoy plating yarn knitting.

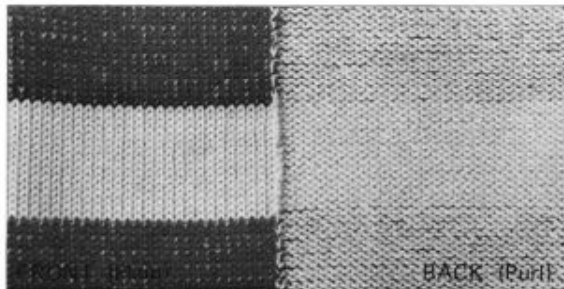

By changing the main yarn, the color of fabric will be changed.

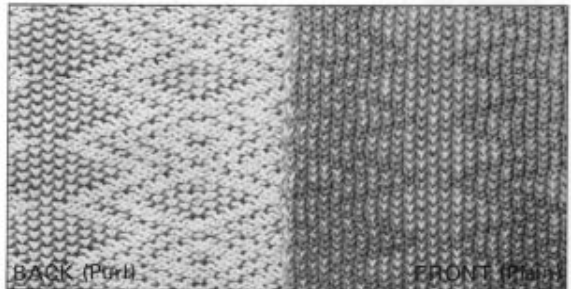

Using the punch card for Tuck stitch patterns (1G, 3G and 13G) with plating yarn knitting you can also enjoy Tuck stitch-Plating yarn knitting. (Preparation and the operation are the same as Tuck stitch pattern and Plating yarn knitting.)

### 5-13. INTARSIA KNITTING

Punch cards are not used for the Intarsia knitting.

Intarsia knitting does not traverse yarns at the back. And you can knit multi-color yarn in one row.

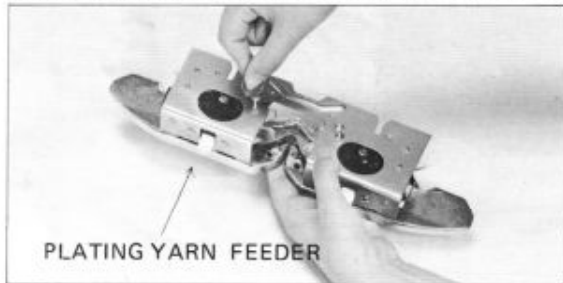

1. Change the yarn feeder to the PLATING YARN FEEDER. (See page 59)

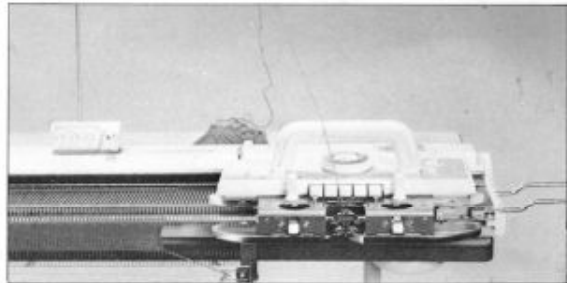

2. Knit several rows of plain knitting and place the K CARRIAGE on the right side of the machine. Take the yarn out of the YARN TENSION UNIT. (The yarn tension unit is not used for the Intarsia knitting.)

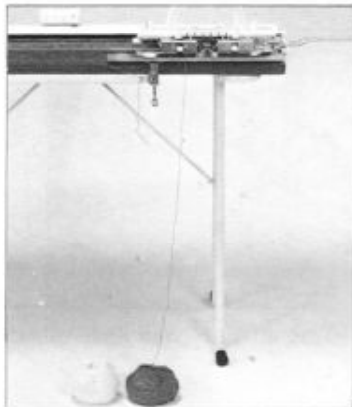

3. Place the main and contrast yarn at your feet. (Leave the main yarn in the main yarn feeder.)

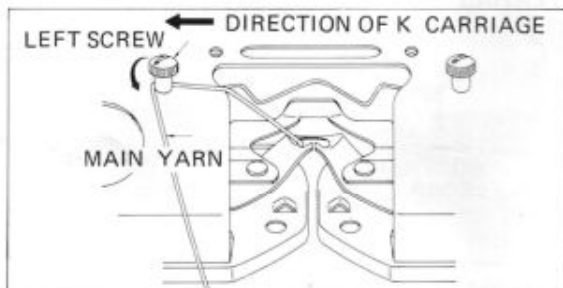

4. Hang the main yarn on the left SCREW as shown in the figure, and pull the yarn gently to give a slight tension. Then move the K CARRIAGE to left.

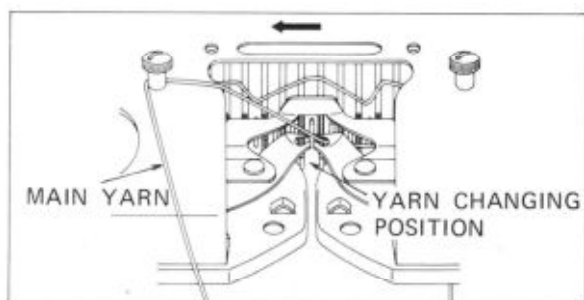

5. Stop the K CARRIAGE at the position where you are going to change the color of yarn.

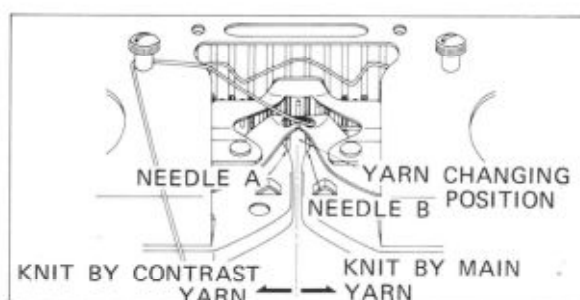

The yarn changing position is just center between two needles.

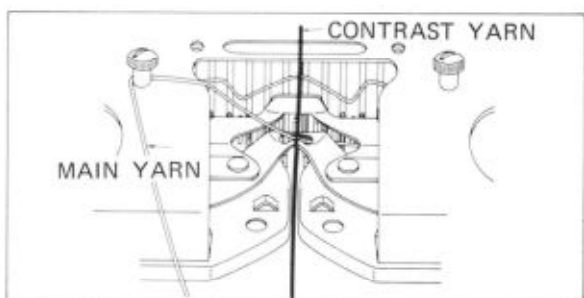

6. Thread the contrast yarn into the main yarn feeder and hang it on the left SCREW as shown in the figure.

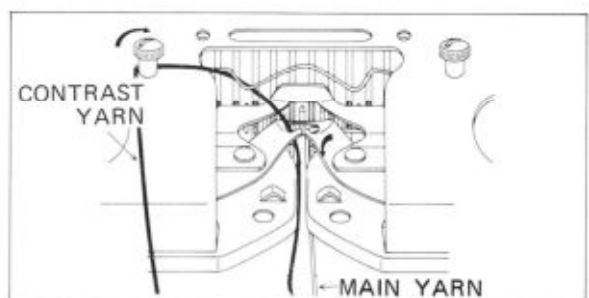
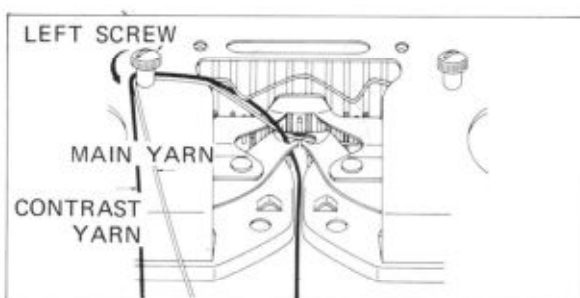

7. Remove the main yarn from yarn feeder and let it hang down.

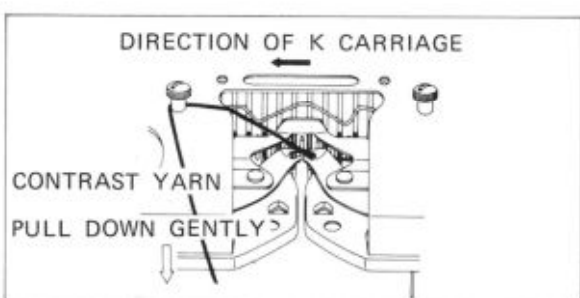

8. Pull the contrast yarn gently and move the K CARRIAGE to left. (Do not pull the yarn too tightly). When you are going to knit using more than one color in one row, repeat steps 6–8.

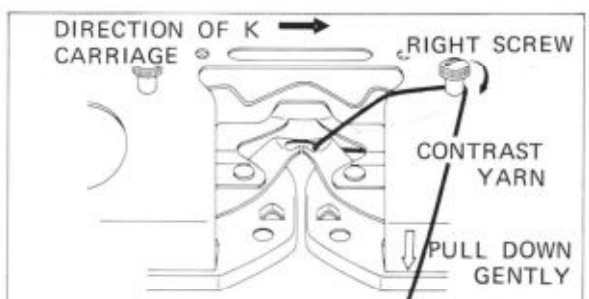

9. After knitting one row, hang the contrast yarn on the right SCREW as shown in the figure. Pull the contrast yarn gently and move the K CARRIAGE to right.

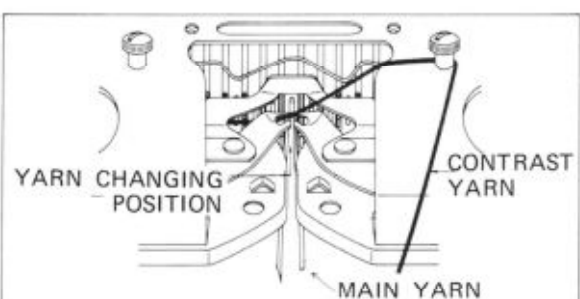

10. Stop the K CARRIAGE at the position where you are going to change the color of yarn. The changing position is just center between two needles.

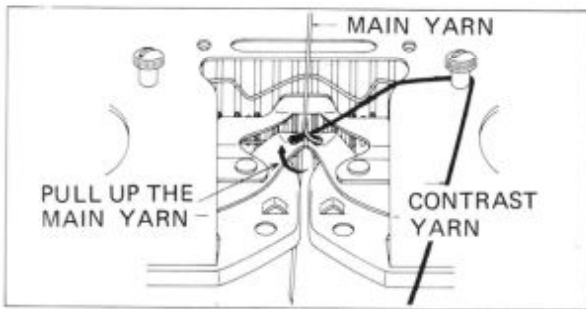

11. Cross the main and contrast yarn at the changing position to avoid making a hole on the knitting.  
 1). Pull up the main yarn as shown in the figure.

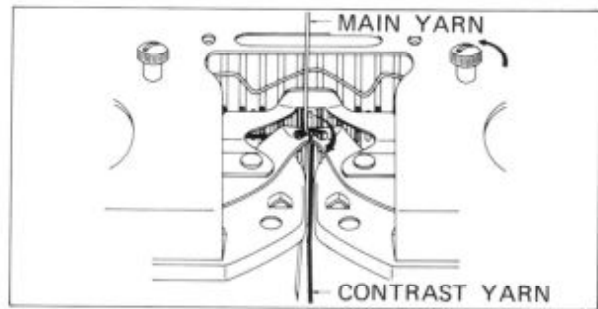

- 2). Remove the contrast yarn from yarn feeder and let it hang down as shown in the figure.

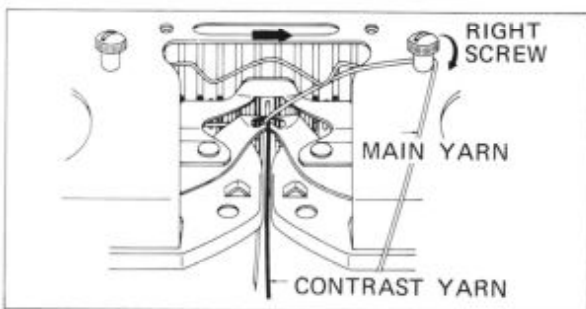

- 3). Hang the main yarn on the right SCREW, and move the K CARRIAGE to right.

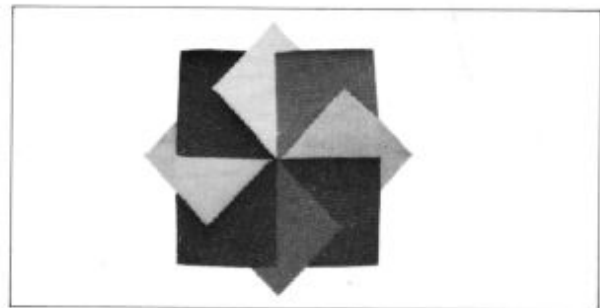

12. Repeat these steps in each row, now Intarsia knitting is completed.

## 5-14. HOW TO DESIGN YOUR OWN PUNCH CARDS

Although there are 25 different punch cards with your machine, you can enjoy many other patterns by using the **PATTERN BOOK** that is available separately.

1. Select a pattern you wish to knit.  
 Then mark on the **BLANK CARD** according to the pattern.
2. Punch out the marked blocks on the card by using the **CARD PUNCHER** that is available separately.  
 When you punch holes by mistake, you can close the holes with tape.

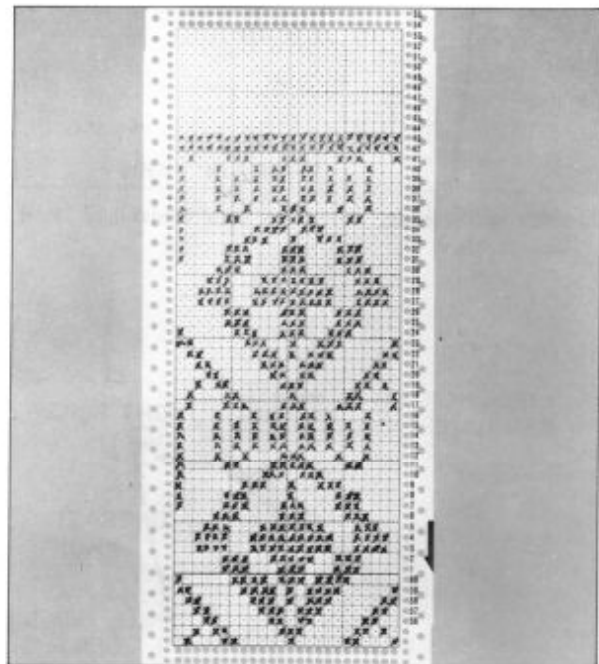
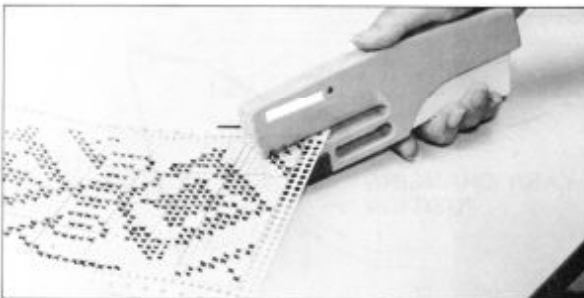

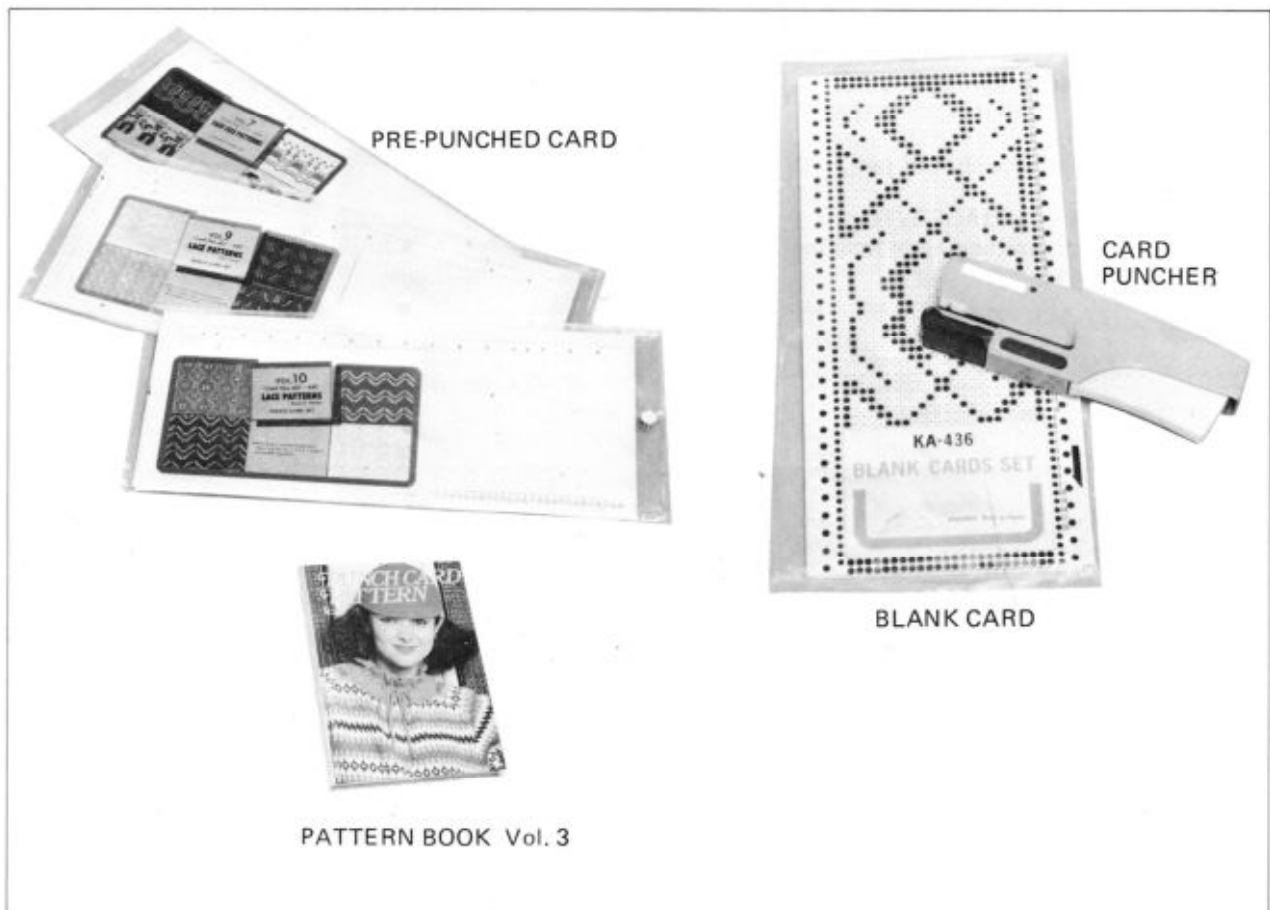

BLANK CARDS, CARD PUNCHER, PATTERN BOOK Vol. 3 and PRE-PUNCHED CARDS (vol. 1, 2, 5, 6, 7, 8, 9 and 10) are available separately. You can design your own patterns by marking and punching the card in the same manner.

## 6. KNOWLEDGE OF PATTERN KNITTING

### 6-1. IF YOU MAKE MISTAKES IN PATTERN KNITTING USING THE PUNCH CARDS... HOW TO CORRECT THEM.

#### 6-1-1. If the K carriage should jam.

Do not move the K CARRIAGE by force. Remove it, then start knitting again from the beginning of the row.



1. Set the CARD LOCK LEVER to the "●" mark.

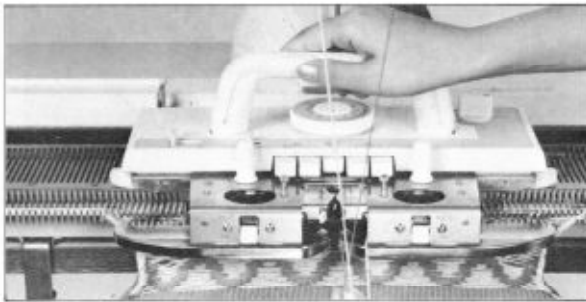

2. 1). Take the yarn out of the YARN FEEDER. When knitting Fair-isle patterns or Weaving patterns, take the second color yarn out of the YARN FEEDER, too.

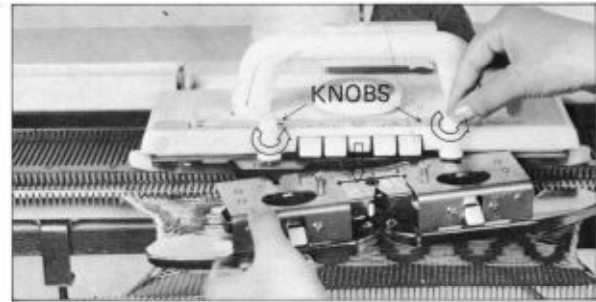

2). Loosen the KNOBS and remove the SINKER PLATE ASSEMBLY from the K CARRIAGE.

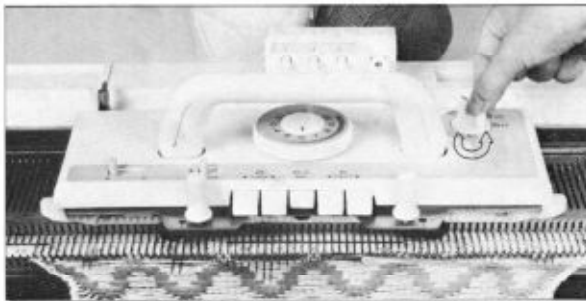

3. Set the CHANGE KNOB to position CR to release the K CARRIAGE from the machine.



Lift up the K CARRIAGE to remove.

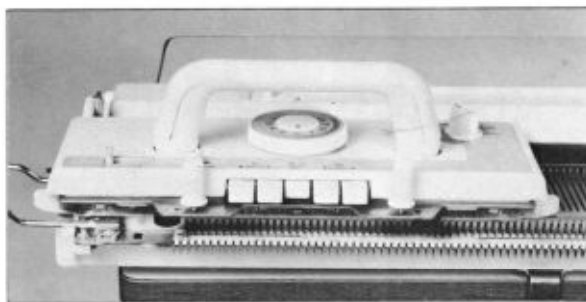

4. Place the K CARRIAGE on the machine at the side toward which the K CARRIAGE was moved.

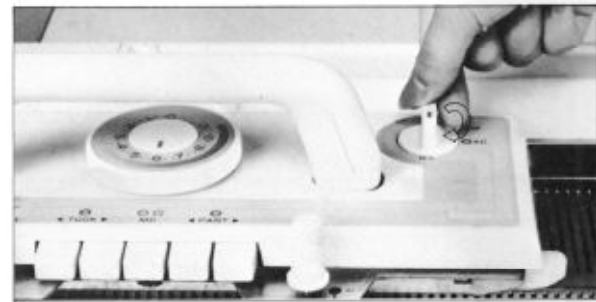

5. 1). Set the CHANGE KNOB to position N.L. The CAM BUTTONS will be restored automatically.



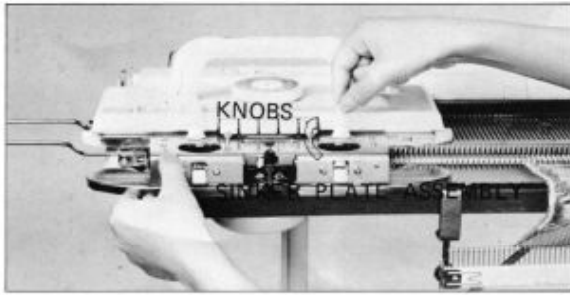

2). Return the SINKER PLATE ASSEMBLY to the K CARRIAGE.

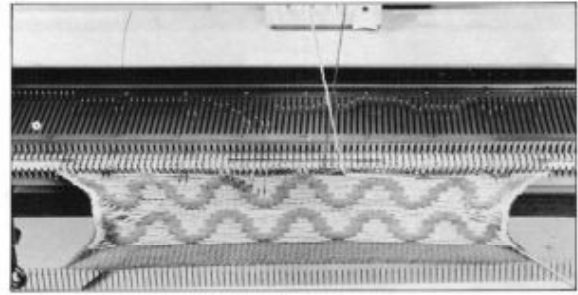

6. Unravel a row of knitting.

- 1). Using the TRANSFER TOOL, transfer the stitches on the stem of the needle to the HOOK of the needle so they will not drop.

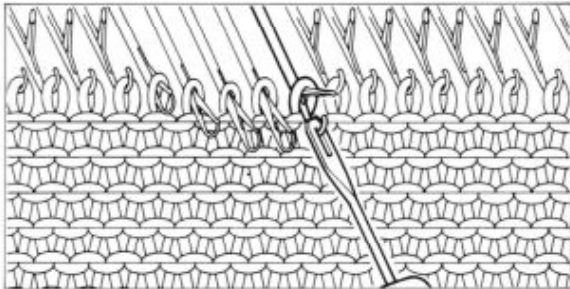

1-1). Place the EYE of the TRANSFER TOOL into the HOOK of the needle.

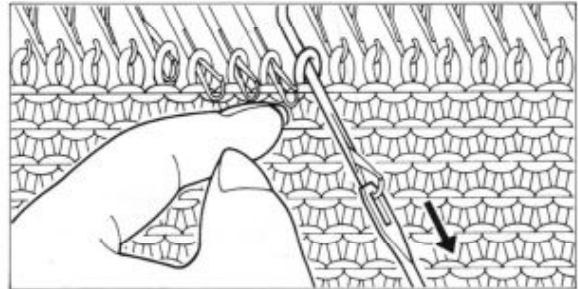

1-2). Hold the TRANSFER TOOL parallel with the needle and pull it toward you.

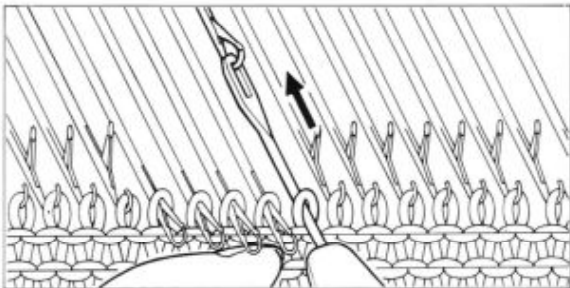

1-3). Push the TRANSFER TOOL toward the machine until the stitch is on the stem of the transfer tool.

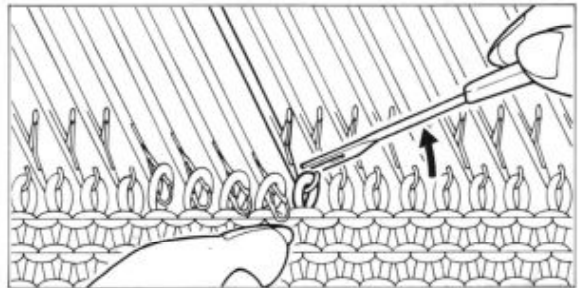

1-4). Transfer the stitch on the TRANSFER TOOL to the HOOK of the needle.

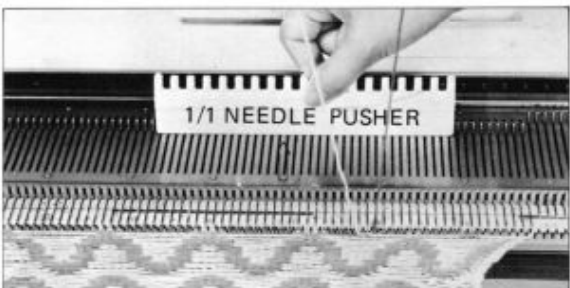

1-5). After transferring each stitch to the hook of a needle, bring back the needles to position B by using the 1/1 NEEDLE PUSHER.

- 2). Unravelling a row of knitting.  
When knitting Fair-isle patterns or Weaving patterns, unravel the second color yarn, too.

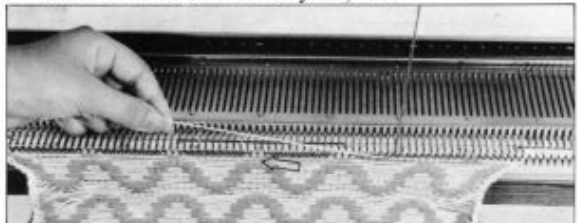

2-1). Hold the second color yarn parallel with the GATE PEGS.



9. Position B needles are selected.



10. Push a cam button according to the pattern you are going to knit.



11. Set the CARD LOCK LEVER to the "▼" mark.



12. Thread the yarn into the YARN FEEDER and start knitting again.  
When knitting, Fair-isle patterns or Weaving patterns, do not forget to thread the second color yarn.



Operate the K CARRIAGE pulling the yarn slightly up.

If the CARRIAGE has not started to knit yet, but the PUNCH CARD has been rotated.

Do not move the CARRIAGE.

Set the CARD LOCK LEVER to "●".

- 1). Unravel the incorrect rows.
- 2). Rewind the PUNCH CARD in the same number of the rows as unravelled, and one step more.
- 3). The other operations are the same as explained above.

If you want to move the CARRIAGE without knitting, you must set the CHANGE KNOB to "N-L" and push in both "PART" buttons.

If the Carriage has not started to knit yet, and the PUNCH CARD has not rotated.

Do not move the CARRIAGE.

Set the CARD LOCK LEVER to "●".

- 1). Unravel the incorrect rows.
- 2). Rewind the PUNCH CARD in the same number of rows as unravelled.
- 3). The other operations are the same as explained above.

**6-2. IF YOU MAKE MISTAKES ON  
KNITTING DOUBLE LENGTH  
PATTERNS ...  
HOW TO CORRECT THEM.**

**Correct the mistakes in the  
same way as  
Pattern Knitting previously  
instructed.**

Reset the PUNCH CARD according to the right table.

When you unravel the knitting, the K CARRIAGE and the yarn must be on the opposite side.

In case the K CARRIAGE has not started to knit yet, but the PUNCH CARD has been rotated, rewind the PUNCH CARD according to the right table and one step in addition.

In Case the Carriage has started Knitting.

Number of unravelling row	Direction in which the Carriage has been moved	
	→	←
1	Rewind the Punch card 0 step (s)	Rewind the Punch card 1 step (s)
2	1	1
3	1	2
4	2	2
5	2	3
6	3	3
7	3	4
.	.	.
.	.	.
.	.	.

## 7. BASIC OPERATION PRACTICE III (LACE PATTERN KNITTING)

### 7-1. LACE PATTERN KNITTING

#### 1. L CARRIAGE

You can select the needles and transfer the stitches automatically by using the L CARRIAGE.

#### LACE CHANGE LEVER

- N ..... Normal lace patten knitting.
- F ..... Fine-lace pattern knitting.

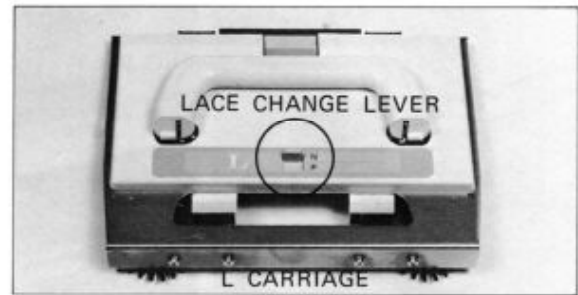

### 7-2. HOW TO SET THE L CARRIAGE

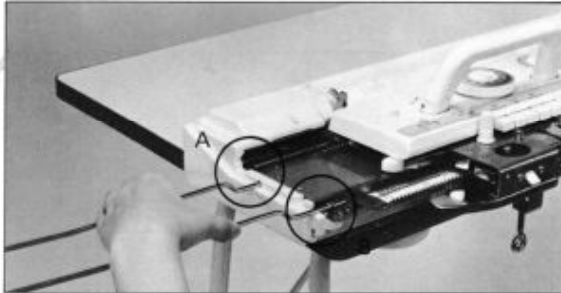

1. Insert the EXTENSION RAILS into the holes (A and B) at both sides of the machine to avoid dropping of the L CARRIAGE.

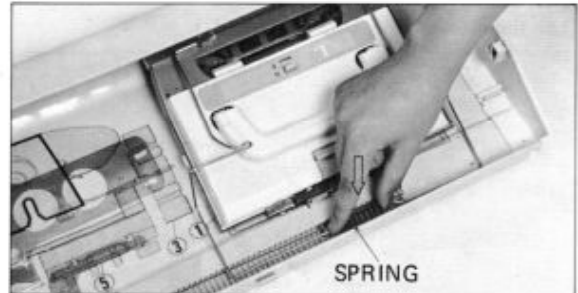

2. 1). Remove the L CARRIAGE from the carrying case, by depressing the SPRING.



- Push the RELEASE BUTTON to remove the L CARRIAGE.

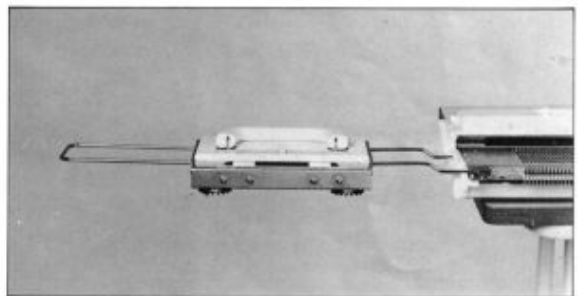

3. Place the L CARRIAGE securely on the left side EXTENSION RAIL.

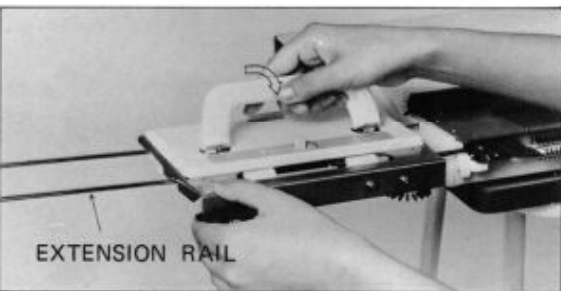

Then set up the L CARRIAGE HANDLE.

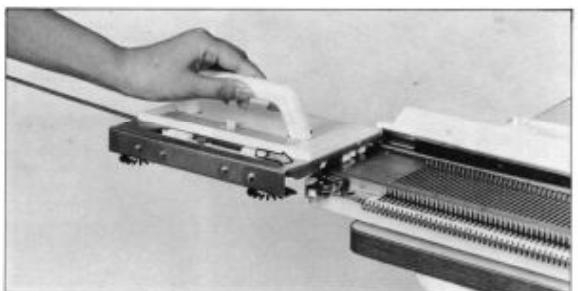

4. Slide the L CARRIAGE onto the NEEDLE BED and make sure that the L CARRIAGE is set correctly.

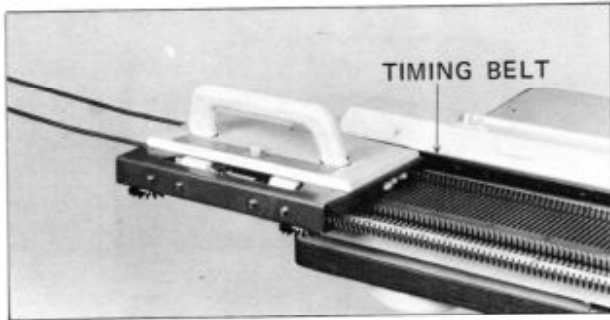

The TIMING BELT must move by moving the L CARRIAGE.

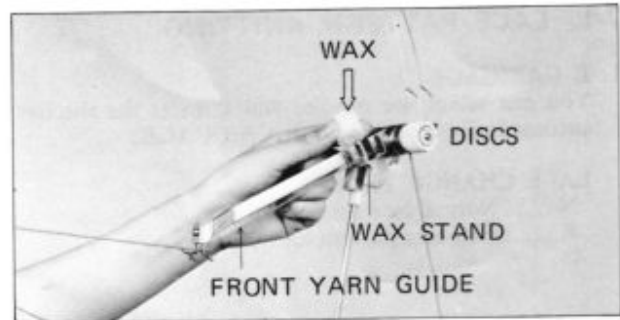

5. When you start Lace pattern knitting, set the WAX on the special stand.

### 7-3. LACE PATTERN KNITTING FINE-LACE PATTERN KNITTING

(Use the Punch Cards No. 20G - 25G).

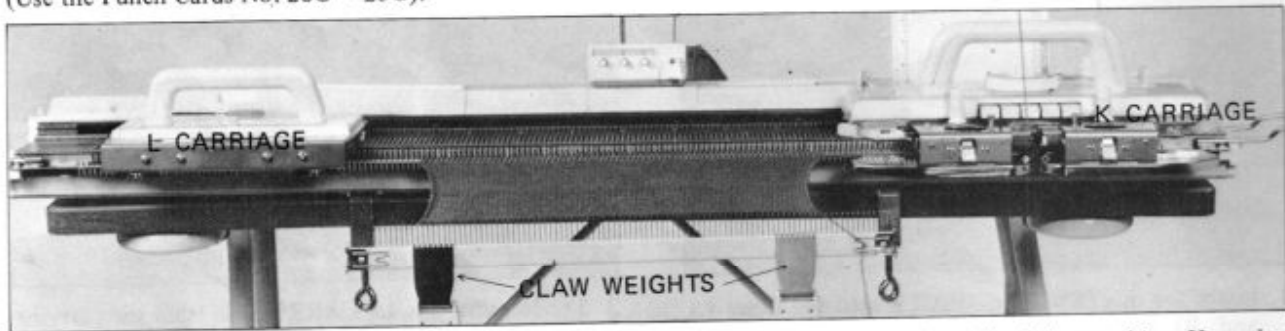

1. Knit several rows in plain Knitting with the K CARRIAGE and put it on the right side of the machine. Hang the CLAW WEIGHTS onto the CAST-ON COMB (as shown in the figure) to avoid dropping stitches.

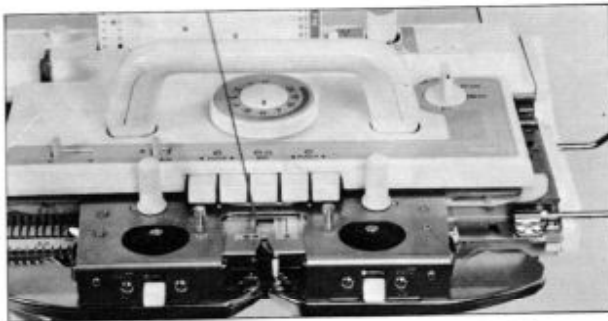

2. Set the PUNCH CARD. Set the card lock lever to "N".

3. Make sure that the CHANGE KNOB of the K CARRIAGE is set to position N-L.

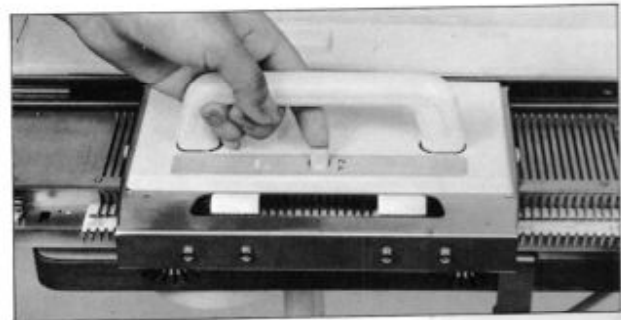

4. Set the LACE CHANGE LEVER to position N or F according to the pattern you are going to knit.  
N ..... Normal lace pattern knitting.  
F ..... Fine-lace pattern knitting.

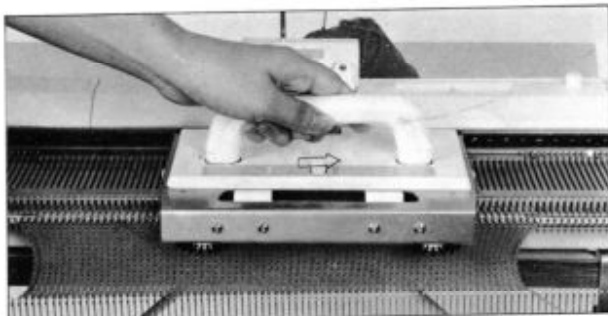

5. Move the L CARRIAGE to right.

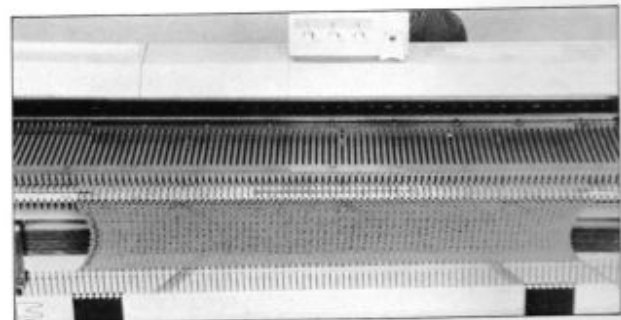

Position B needles are selected by L CARRIAGE.

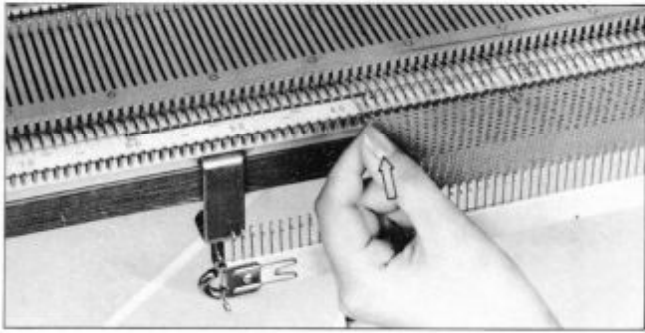

6. If either end needle of the knitting is brought forward to position D, push it back by hand to position B.

8. Move the L CARRIAGE and the K CARRIAGE according to the arrows on the left side of the punch card.

- ..... Move the L carriage from left to right.
- ← ..... Move the L carriage from right to left.
- ⤷ ..... Move the K carriage from right to left and come back to right side of the machine.

When the symbols → and ⤷ are indicated same step, first move the K CARRIAGE, then operate the L CARRIAGE.

When you operate the K CARRIAGE, the L CARRIAGE is always on the left side of the machine.

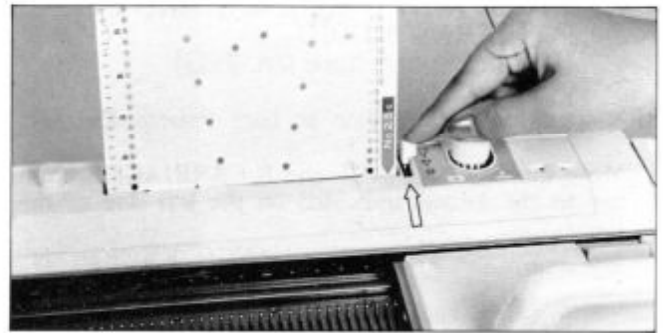

7. Set the CARD LOCK LEVER to the "▼" mark.

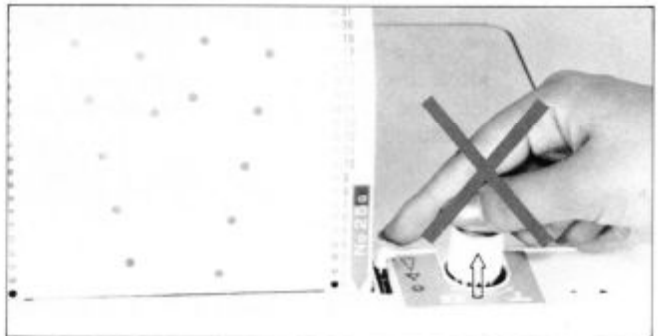

\* When knitting Lace patterns or Fine-Lace patterns do not set the CARD LOCK LEVER to the "▼" mark.

#### Lace Patterns

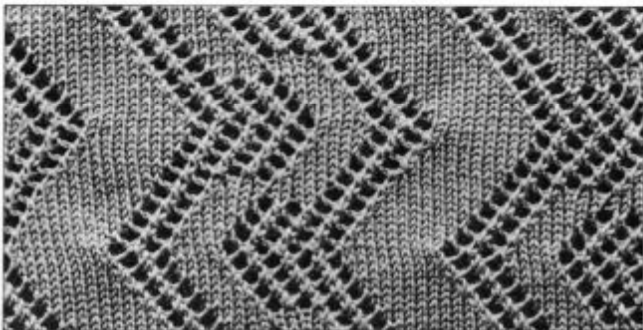

Card No. 24G, Tension No. 5

#### Fine-Lace Patterns

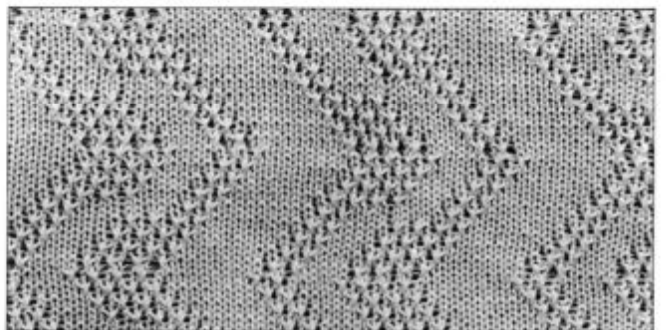

Card No. 24G, Tension No. 6

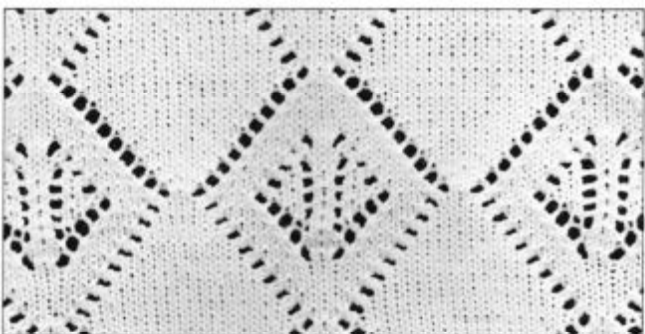

Card No. 25G, Tension No. 5

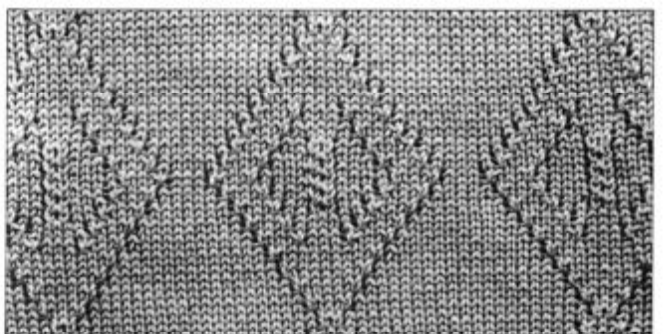

Card No. 25G, Tension No. 6

**7-4. WHEN KNITTING LACE AND FINE-LACE PATTERNS MIXED**  
**(Use the Punch Card No. 22G)**

The operation is the same as Lace Pattern Knitting.

1. Move the L CARRIAGE and K CARRIAGE according to the arrows indicated on the left side of the Punch Card.

→ ..... Set the LACE CHANGE KNOB to "N" or "F" position and then move the L carriage from left to right.

← ..... Set the LACE CHANGE KNOB to "N" or "F" position and then move the L carriage from right to left.

Remarks: When the color of the arrow on the punch card will be changed from RED (BLUE) to BLUE (Red), change the LACE CHANGE KNOB from "N" ("F") to "F" ("N").

↻ ..... Move the K CARRIAGE from right to left and come back to right side of the machine.

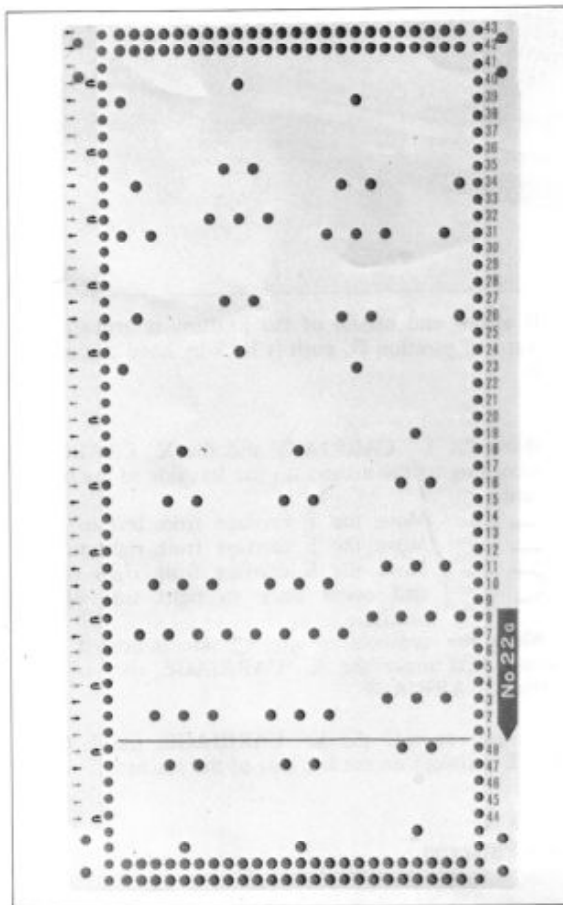

Starting with Lace Pattern  
 ("N" Position)

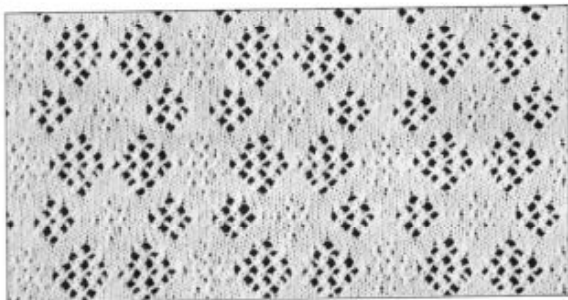

Starting with Fine-lace Pattern  
 ("F" Position)

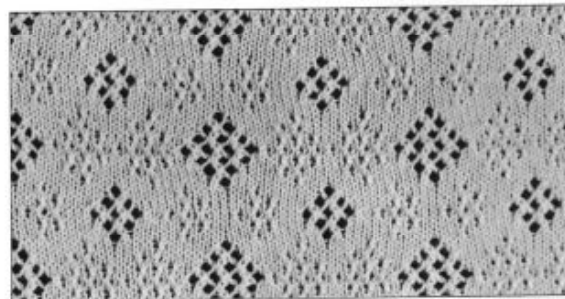

## 8. KNOWLEDGE OF LACE PATTERNS

### 8-1. IF THE L CARRIAGE SHOULD JAM

Do not move the L CARRIAGE by force. Remove it, then start knitting again.

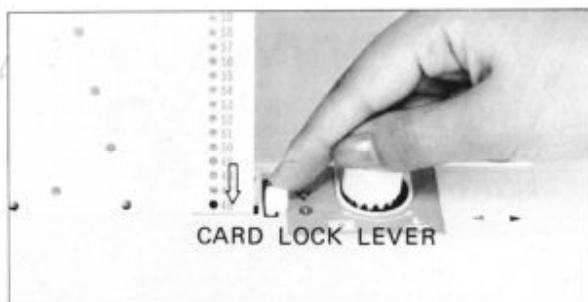

1. Set the CARD LOCK LEVER to the "●" mark.



2. Push the RELEASE BUTTON toward you to remove the L CARRIAGE.  
If the L CARRIAGE is caught on the needles, take care in removing it.

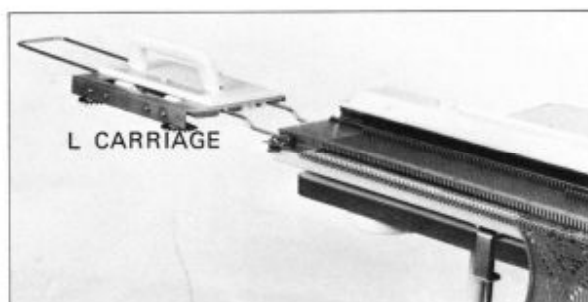

3. Place the L CARRIAGE firmly on the EXTENSION RAIL at the side toward which the L CARRIAGE was moving.



The ARROW MARK indicates the direction of the carriage.

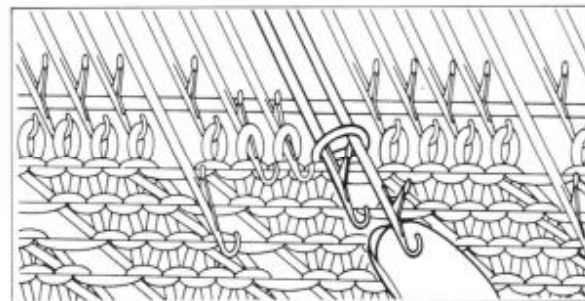
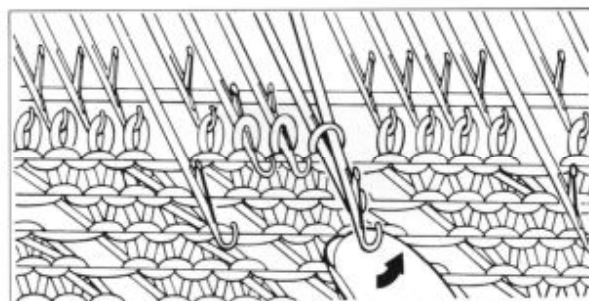

4. If you see the needles caught with each other, separate them by lifting their tips as shown in the figure.



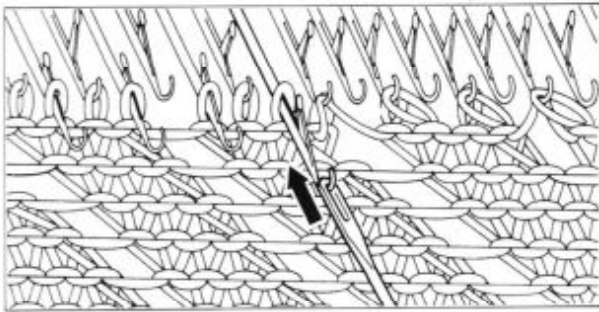

5. If the stitches are on the stem, transfer the stitches to the hooks of the needles by using the TRANSFER TOOL.

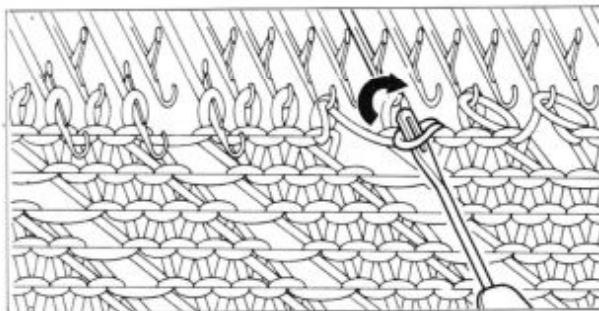

6. Return the transferred stitches to the adjacent needles by using the TRANSFER TOOL as shown in the figure.

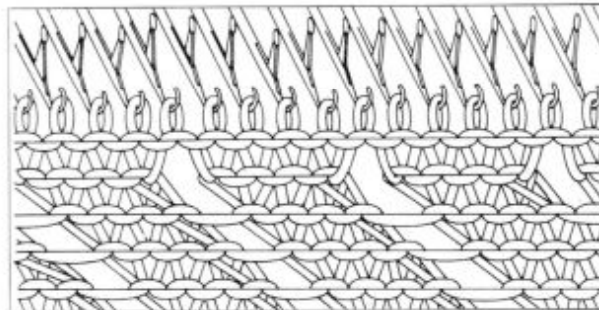
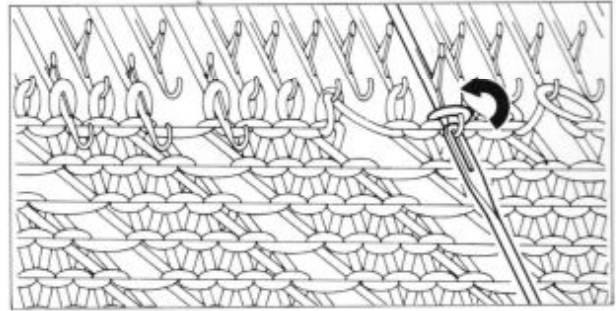

Return all the needles to position B.

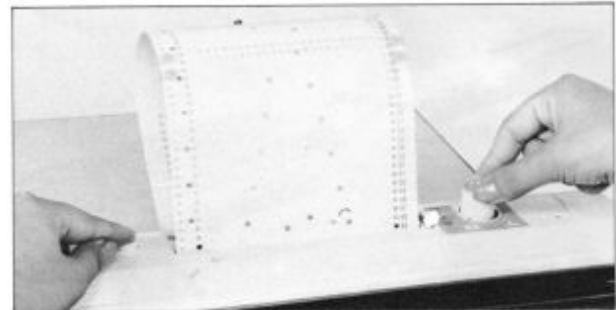

7. Rewind the PUNCH CARD one row. Set the card lock lever to "●".



8. Operating the L CARRIAGE.



The needles will be selected.

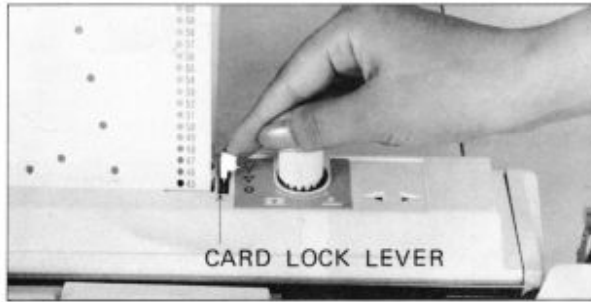

9. Set the CARD LOCK LEVER to the “▼” mark.

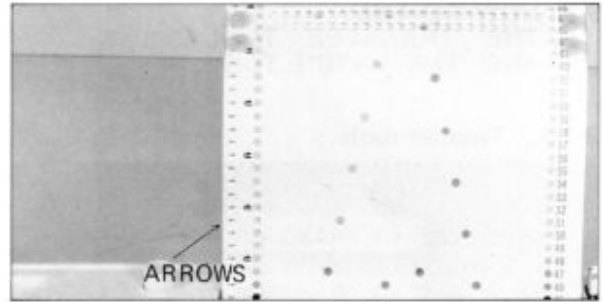

10. Operate the L CARRIAGE and the K CARRIAGE according to the arrows on the punch card.

## 8-2. UNRAVELLING THE KNITTING

If there are dropped stitches, unravel the knitting. Then start knitting again.

Unravel the knitting after returning the stitches to hook of the needles and return them to position B.

Unravel the knitting two rows and rewind the punch card to the last → C mark.

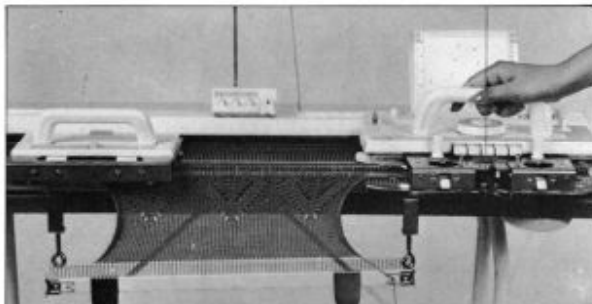
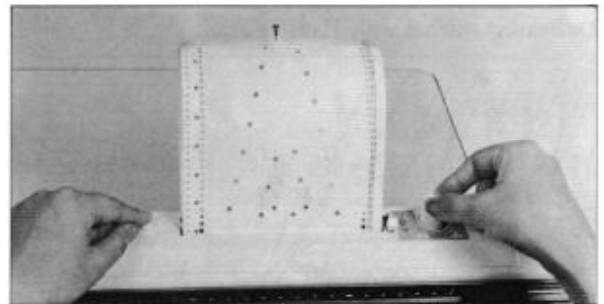

When starting to knit again, first knit 2 rows with K CARRIAGE then operate the L CARRIAGE.

# LESSON 3

## 9. MAKING A GARMENTS

### 9-1. HOW TO USE THE TRANSFER TOOL AND THE LATCH TOOL

#### 9-1-1. Transfer tools

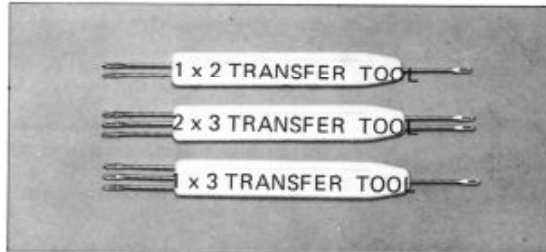

How to hold the transfer tool.

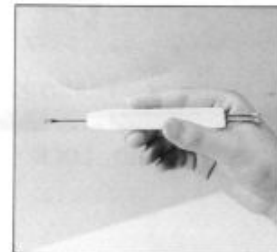

Decreasing stitches with Transfer Tool.

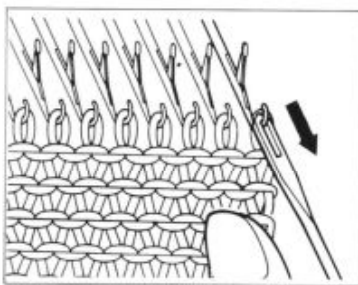

1. Hook the eye of the TRANSFER TOOL on the hook of the needle and pull it toward you.

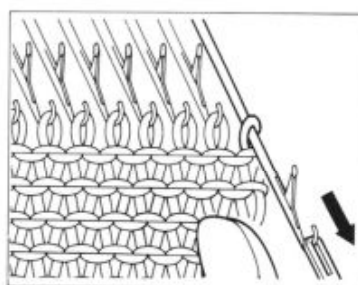

Hold your other hand against the knitting so that it will not be brought forward. The stitch in the hook of the needle will slide behind the latch and onto the stem of the needle.

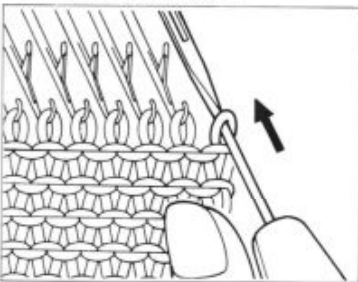

2. Hold the transfer tool parallel with the needle and push it all the way back until the stitch is transferred onto the TRANSFER TOOL.

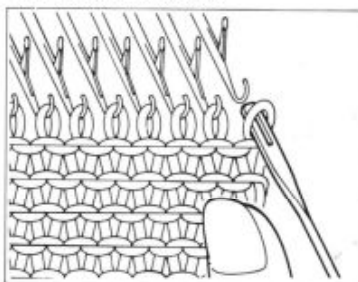

3. Remove the TRANSFER TOOL from the hook of the needle taking care not to drop the stitch from the TRANSFER TOOL.

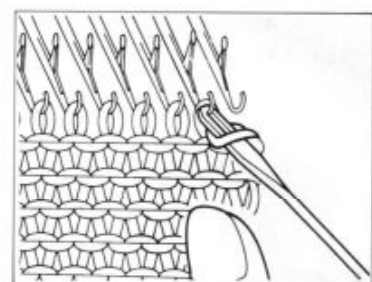

4. Hook the transfer tool onto the hook of the adjacent needle.

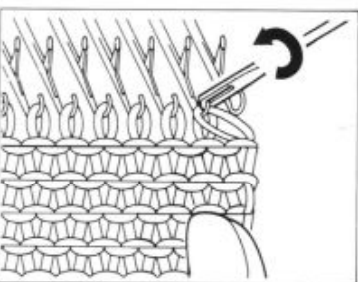

5. Transfer the stitch from the transfer tool onto the hook of the needle.

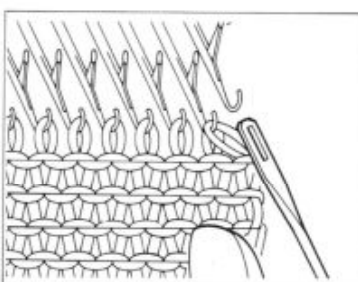

6. Remove the transfer tool from the hook of the needle and return the empty needle to position A.

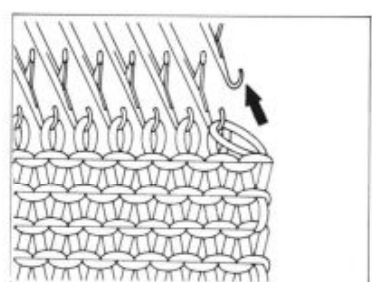

## 9-1-2. Latch Tool.

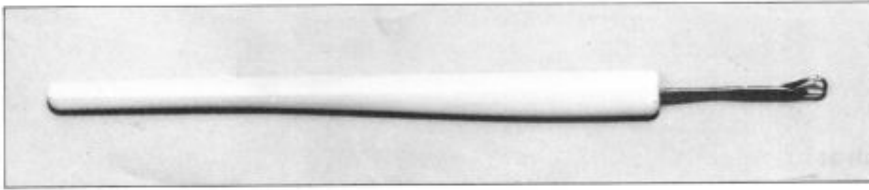

How to hold the latch tool.

### Ribbing with the Latch Tool.

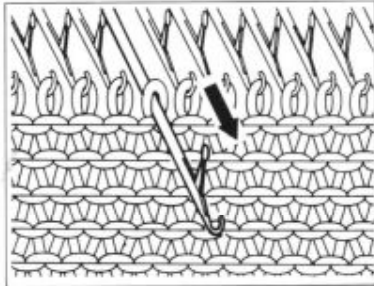

1. Bring one needle forward to position E by hand and return it to position A.

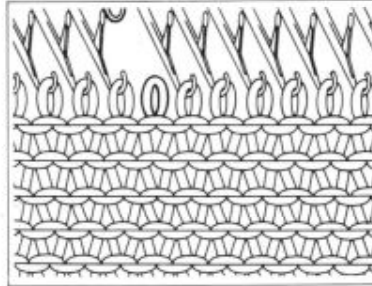

One stitch has been dropped from the hook of the needle.

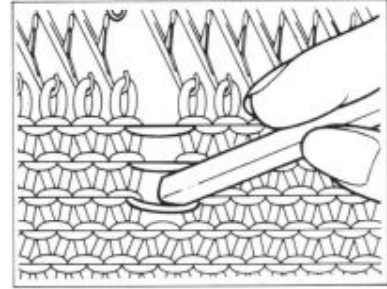

2. Using the tip of your LATCH TOOL, unravel your knitting.

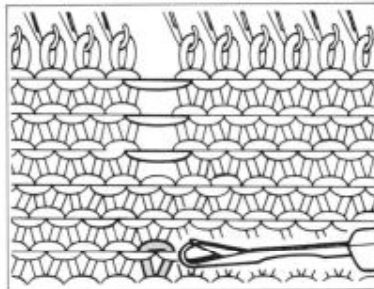

3. Drop the stitch in the line you wish to rib to a few rows above where you are to start ribbing. Then place the LATCH TOOL in the stitch where you wish to start ribbing.

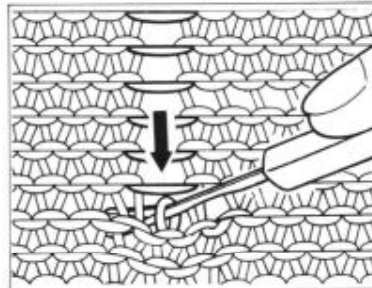

4. Depress the LATCH TOOL to drop the last few stitches. The stitch is on the stem of the latch tool.

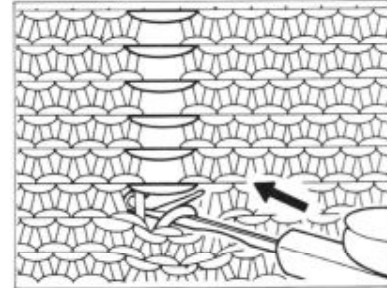

5. Hold the knitting firmly. Push the LATCH TOOL away from you until the stitch on the latch tool is behind the latch.

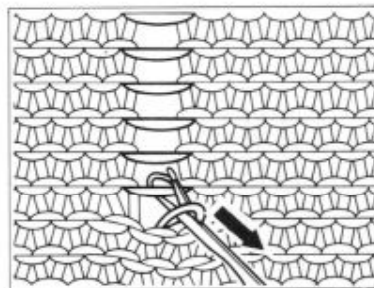

6. Catch the next parallel thread with the hook of the latch tool and pull the LATCH TOOL toward you.

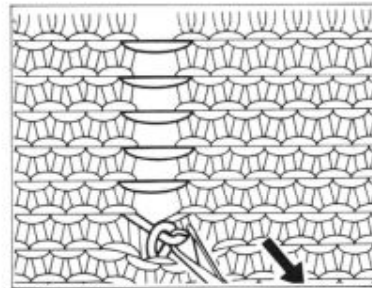

7. The latch will close with the new yarn in the hook. Pull this new yarn through the stitch on the stem of the latch tool to form a new stitch. Do not pull the latch tool strongly.

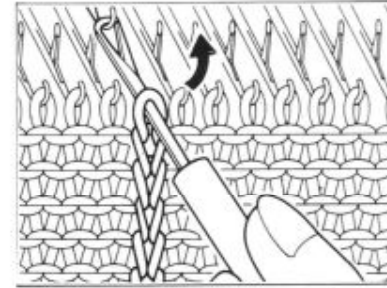

8. Repeat this until you reach the top, and hook the last stitch on the hook of the needle.

**9-2. INCREASING AND DECREASING STITCHES PICKING UP DROPPED STITCHES**

**9-2-1. Increasing stitches**

**9-2-1-1. Increasing one stitch at either edge of the knitting. Simple method.**

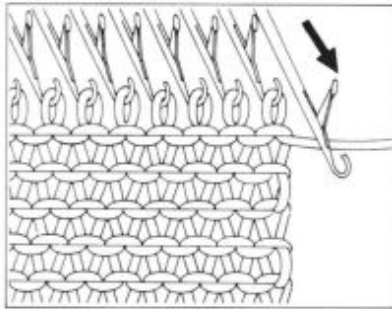

1. On the K carriage side, push one needle into working position B from position A.

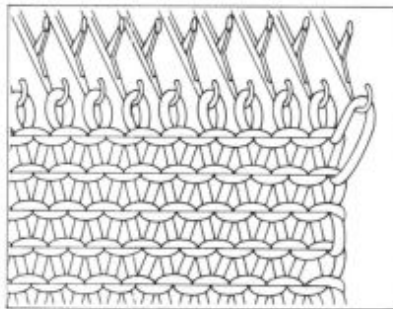

2. Operate the K carriage and knit one row. The empty needle will pick up the yarn.

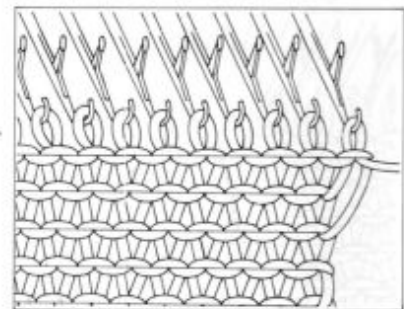

3. Knit another row. You have increased one stitch.

**9-2-1-2. Increasing one stitch at either edge of the knitting. Full fashioned method.**

1. Using the 1 x 2 TRANSFER TOOL, move the stitches out one needle so that the third needle from the end becomes empty.

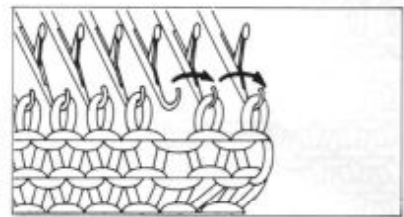

2. To fill in the empty needle pick up the purl side of either adjacent stitch on the lower row.

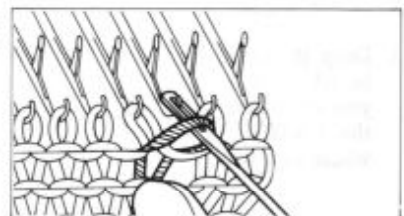

**9-2-1-3. Increasing several stitches at either edge of the knitting.**

1. On the K carriage side, push the needles to be increased, to position E from A.
2. Wind the yarn loosely around the stems of each needle pushed to position E.

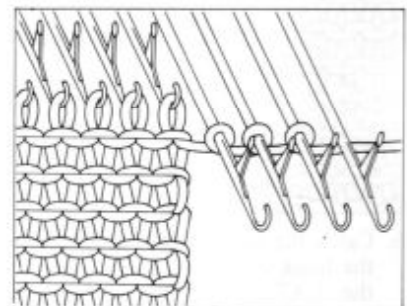
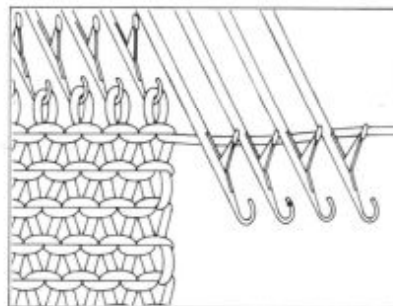

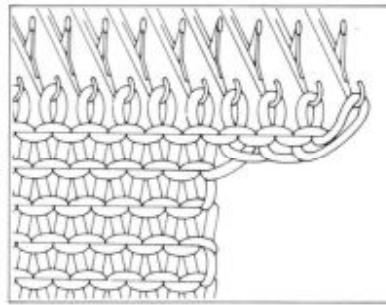
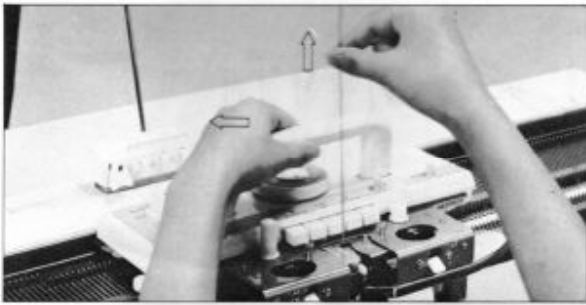

3. Pull up any slack between the K CARRIAGE and the end stitches and knit one row.

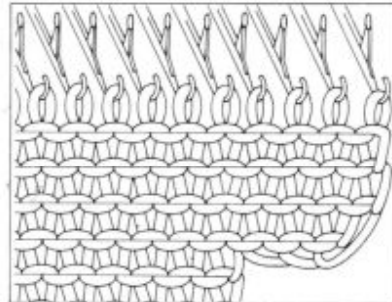
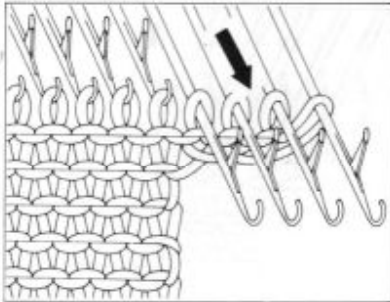

4. Push the needles with the increased stitches to position E and knit one row.

Repeat this two or three rows, and then continue to knit.

## 9-2-2. Decreasing stitches.

### 9-2-2-1. Decreasing one stitch at either edge of the knitting. Simple method.

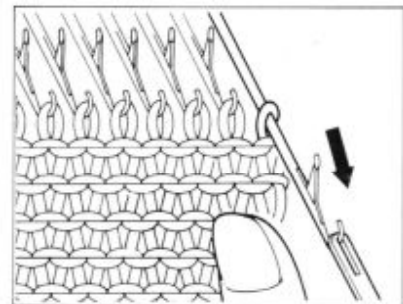
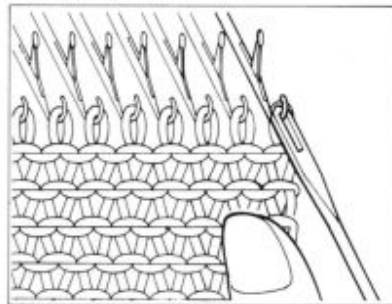

1. Hook the EYE of the TRANSFER TOOL on the hook of the needle, then pull it toward you.  
Hold your other hand against the knitting so that it is not brought forward.

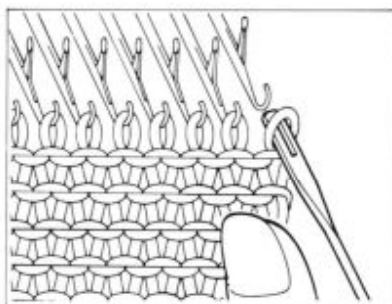
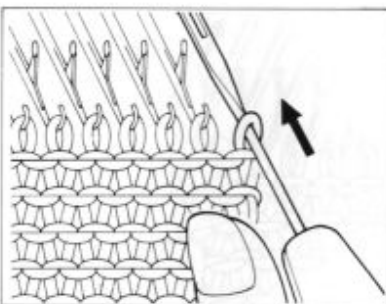

2. Hold the TRANSFER TOOL parallel with the needles and push it all the way back. Then the stitch will be transferred to the TRANSFER TOOL.

3. Remove the TRANSFER TOOL from the hook of the needle taking care not to drop the stitch from the TRANSFER TOOL.

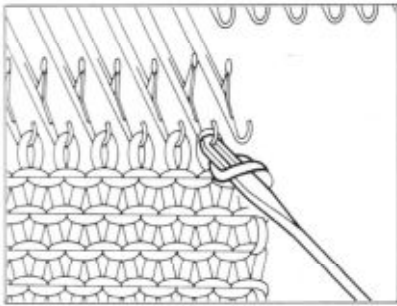

4. Hook the transfer tool on the hook of the adjacent needle.

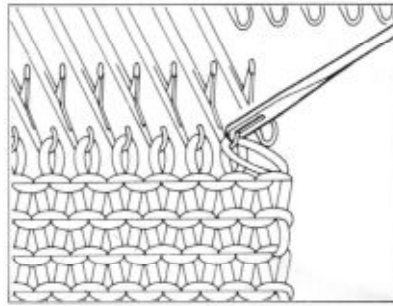

5. Transfer the stitch from the TRANSFER TOOL to the hook of the needle.

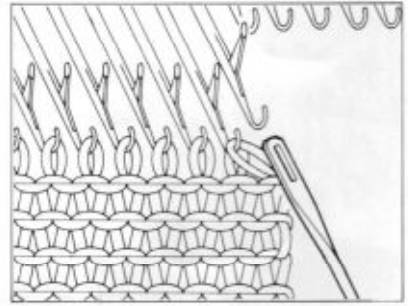

6. Remove the TRANSFER TOOL from the hook of the needle.

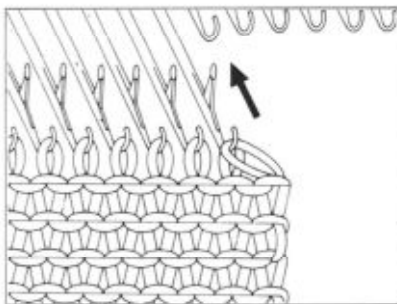

Return the empty needle to position A. Then you have decreased one stitch.

**9-2-2-2. Decreasing one stitch at either edge of the knitting. Full fashioned method.**

Use the 1x2 TRANSFER TOOL to transfer two stitches at the end to the inside needles, and place empty needle out of action to position A.

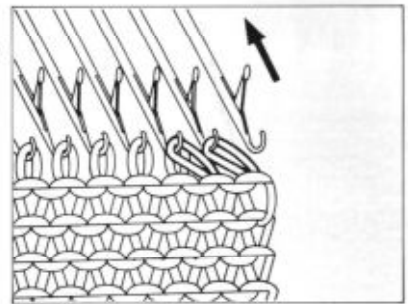

**9-2-2-3. Decreasing several stitches at either side of the knitting.**

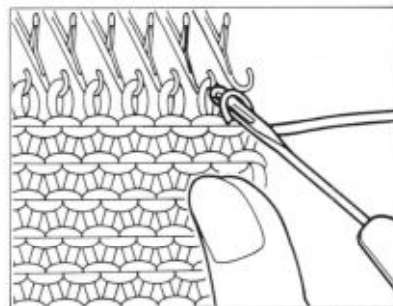

1. On the same side as the K CARRIAGE, transfer the end stitch to the 2nd needle.

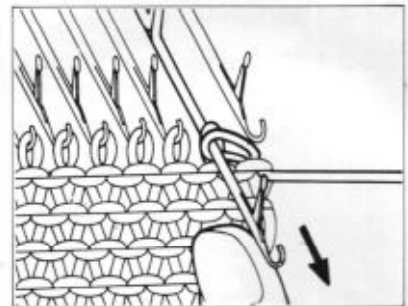

2. Bring forward the needle with the two stitches so that the stitches fall behind the needle latch.

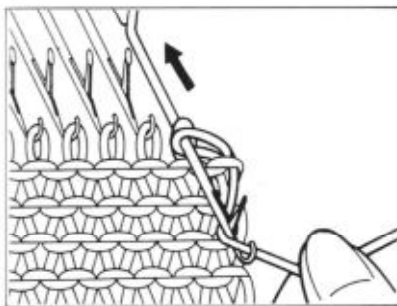

3. Place the yarn in the needle hook, in front of the latch and push the needle back manually to form a single stitch.

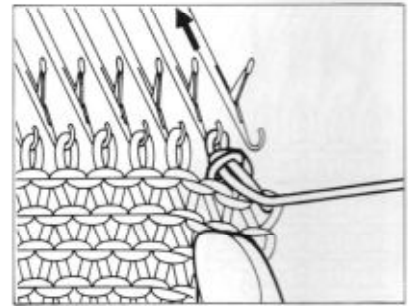
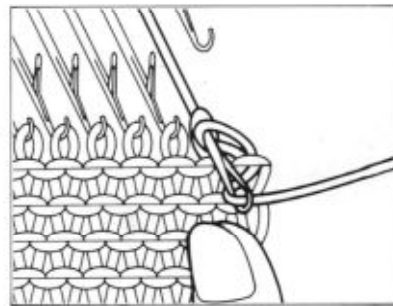

4. Return the empty needle to position A.

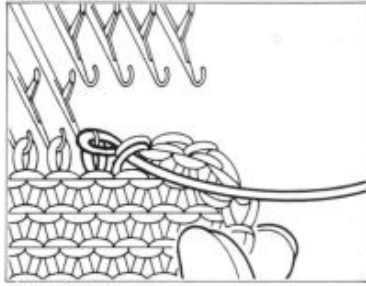

5. Repeat this process for each stitch. Take care not to make the stitches too tight.

When you reach the last stitch, hang the last stitch on the adjacent needle. (Two stitches are on the hook of the needle.)

Then operate the K CARRIAGE.

### 9-2-3. Picking up dropped stitches

#### 9-2-3-1. Repairing a dropped stitch

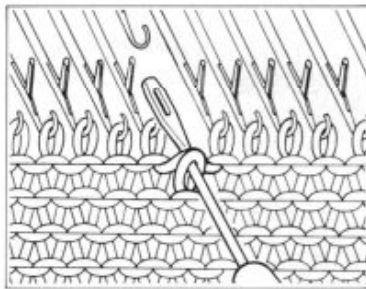

1. Using a TRANSFER TOOL, pick up the stitch (the row below the dropped stitch) and the unknitted yarn and put both of them on the empty needle.

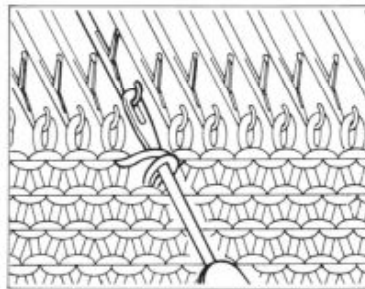

2. Push the needle to position E. Stitch and unknitted yarn are now behind the latch.

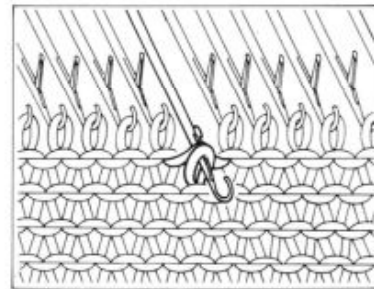

3. Push the needle back until stitch is just behind the latch. Using a TRANSFER TOOL, catch the unknitted yarn into the hook of the needle.



Then return the needle to position B pulling the yarn in the hook through the stitch on the stem of the needle. The stitch has now been reknitted.

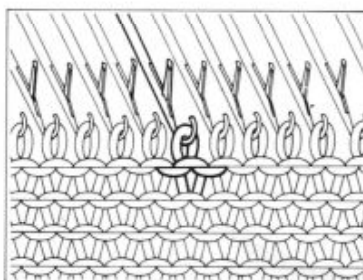

**9-2-3-2. Repairing a stitch that has dropped several rows.**

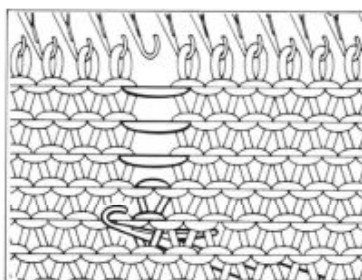

1. Insert the latch tool from behind your knitting through the last stitch that has not dropped.

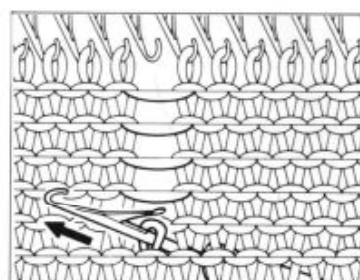

2. Push the latch tool towards you pulling slightly down on your knitting so that the stitch comes behind the latch.

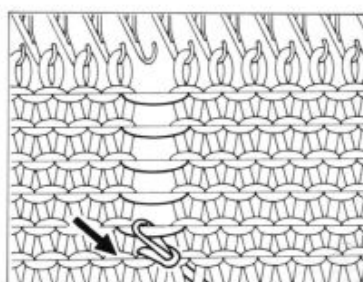

3. Catch the next cross thread into the hook and pull back the LATCH TOOL through the stitch on the stem. There is now one stitch.

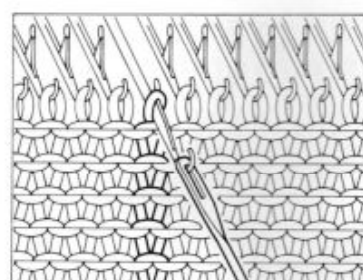
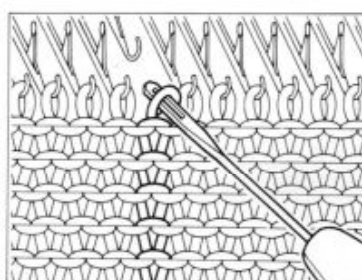
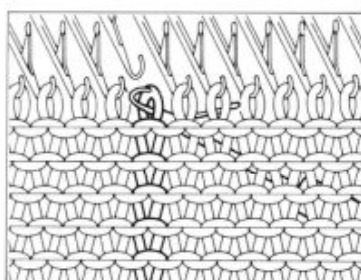
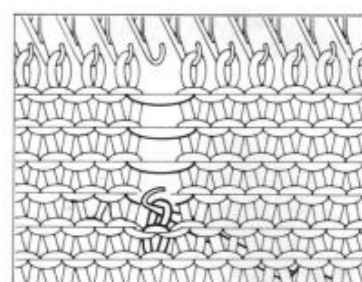

4. Repeat this until you reach the top. Pull the last stitch rather tight to make a bigger loop. Insert the transfer tool into the loop from the front. Carefully remove this stitch from the latch tool and place it on the hook of the needle with your transfer tool.

### 9-3. HOW TO MAKE A HEM

#### 9-3-1. Plain hem

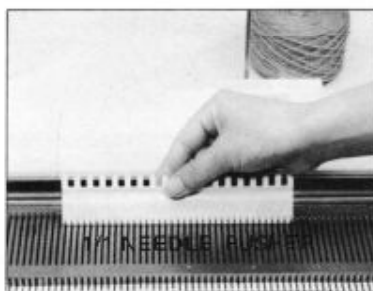

1. Using the 1/1 NEEDLE PUSHER bring forward to position B the required number of needles, after selecting an equal number of needles on either side of the center "0"

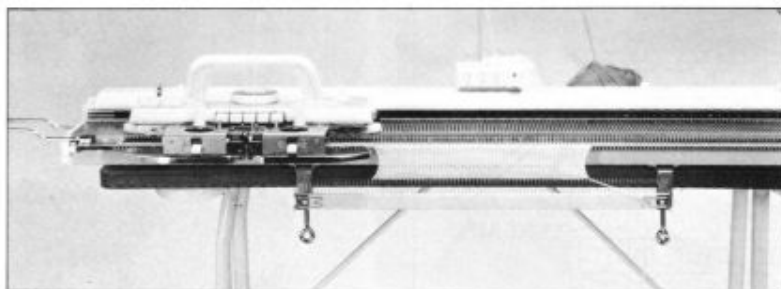

2. Knit about ten rows in plain knitting with waste yarn and put the K CARRIAGE on the left side of the machine.

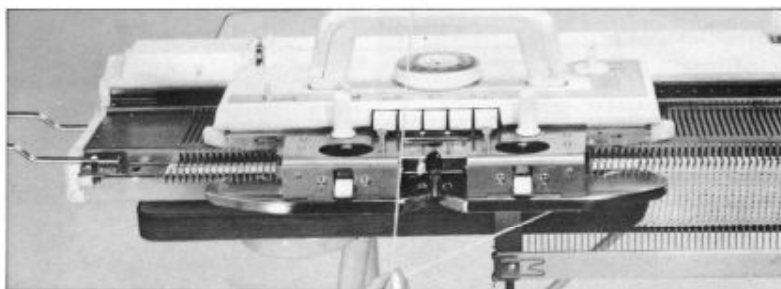

3. Pull the waste yarn out of the YARN FEEDER "A". Remove the CAST-ON THREAD from the accessory box.

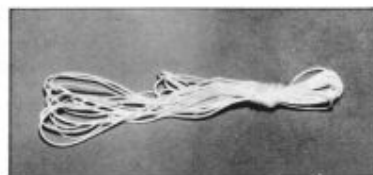

CAST-ON THREAD

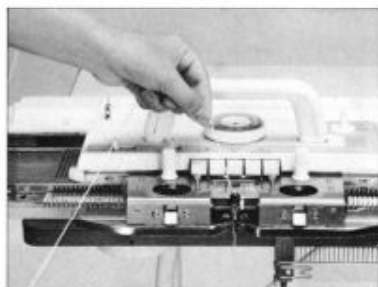

Thread the CAST-ON THREAD into YARN FEEDER "A".

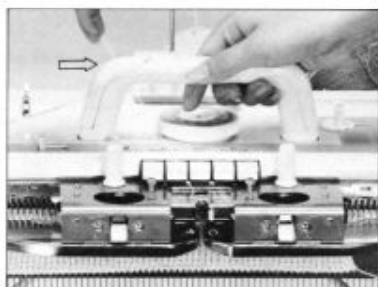

Move the K CARRIAGE to the right holding the CAST-ON THREAD with your left hand.

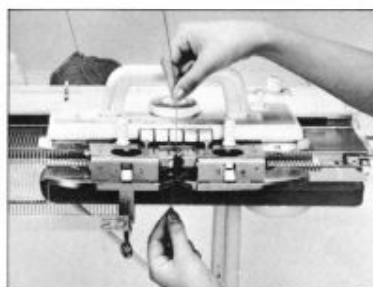

4. Pull the CAST-ON THREAD out of the YARN FEEDER "A" and thread the regular knitting yarn into YARN FEEDER "A". Set the ROW COUNTER at "0".

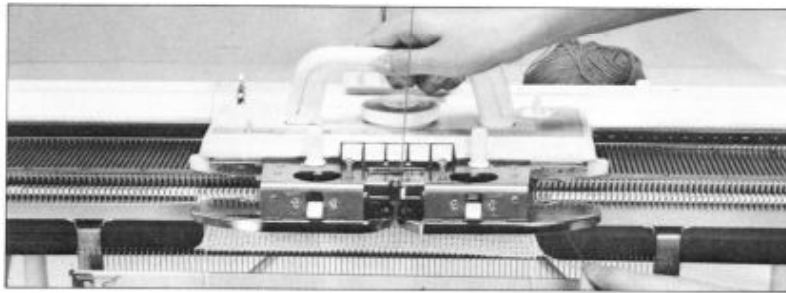

5. Knit in plain knitting with the yarn. For the first row, move the K CARRIAGE holding the yarn under the YARN FEEDER "A" with your left hand at the right edge of the knitting. Knit the number of rows required for double the length of the hem. Remove the CAST-ON COMB from the knitting.

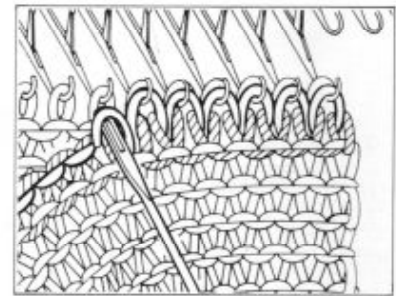
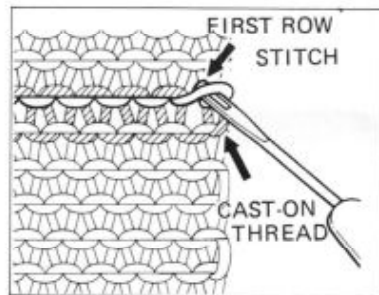
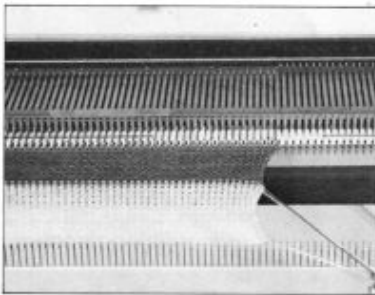

6. Pick up the first stitch of the first row where it meets the CAST-ON THREAD. Insert the TRANSFER TOOL. Hook the stitch onto the first needle. Repeat across the row.

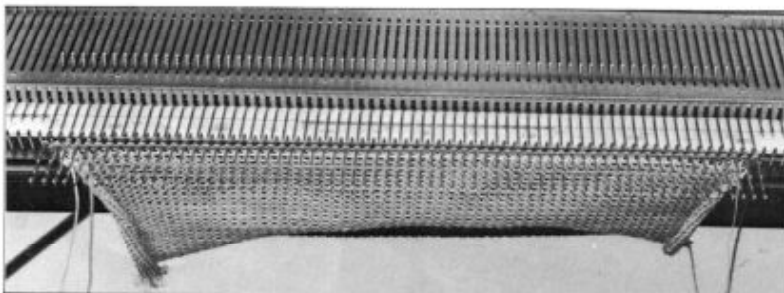

7. After picking up all the stitches, bring all the needles forward to position E. (There will be one less stitch to be picked up than there are needles.)
8. Operate the K carriage and continue to knit in plain knitting.

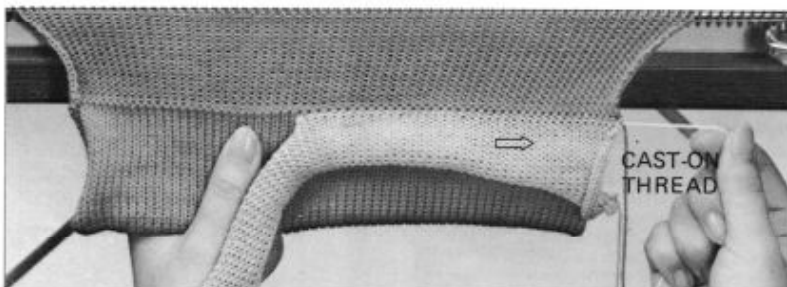

9. After knitting several rows, pull out the CAST-ON THREAD. Then the part knitted with the waste yarn is removed and the PLAIN HEM is made.

### 9-3-2. Picot hem

1. After knitting with waste yarn and CAST-ON THREAD, knit up to half the depth of the hem. (The K CARRIAGE is on the right side of the machine.)

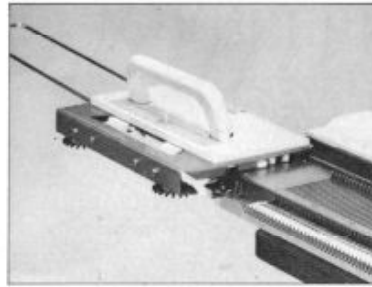

2. Place the L CARRIAGE on the left side EXTENSION RAIL.

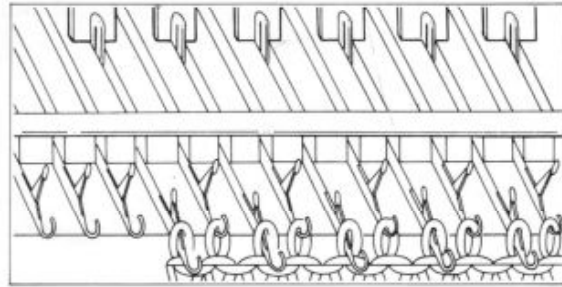

3. Starting with the second needle from either end, bring forward every alternate needle to position D by using the 1/1 NEEDLE PUSHER. End needles must remain in position B.

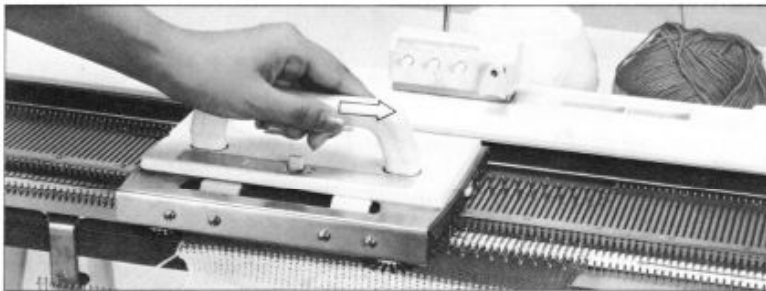

4. Move the L CARRIAGE to right.

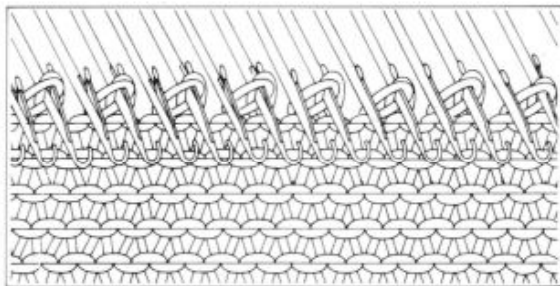

Every second stitch has now been transferred to the adjacent needle.



5. Remove the L CARRIAGE from the machine by pushing the RELEASE BUTTON.

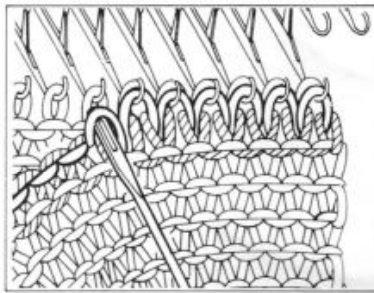
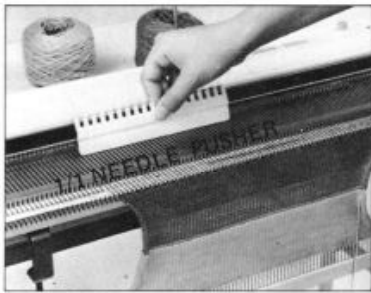

7. Knit the other half of the hem and pick up the stitches in the same way as for the plain hem. After picking all the stitches up, bring the needles to position E.

6. Return the needles to position B.

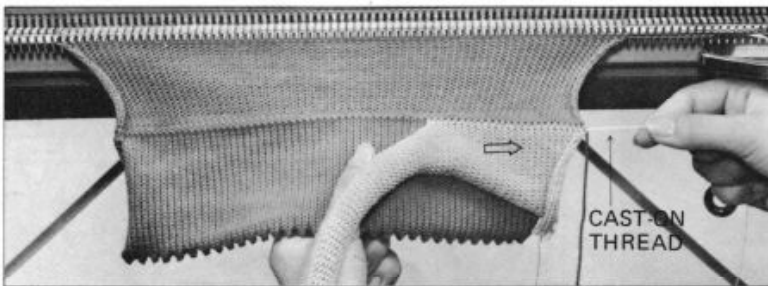

8. After knitting several rows, pull out the CAST-ON THREAD. The part knitted with waste yarn is removed. Then you have made a PICOT HEM.

9-3-3. 1 x 1 Elastic hem

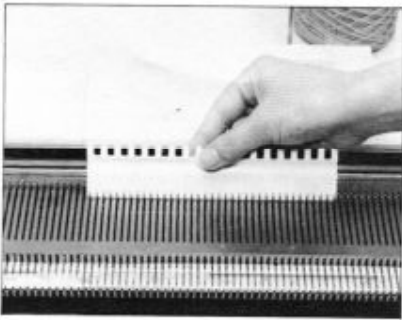

1. Bring forward the needles required to position B by using the 1/1 NEEDLE PUSHER.

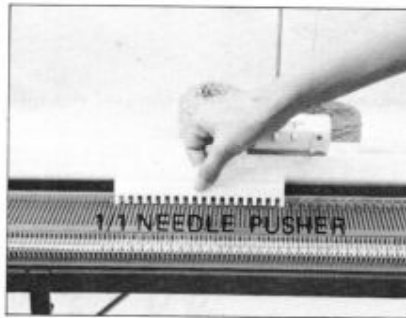

2. Return every other needle to position A by using 1/1 NEEDLE PUSHER.

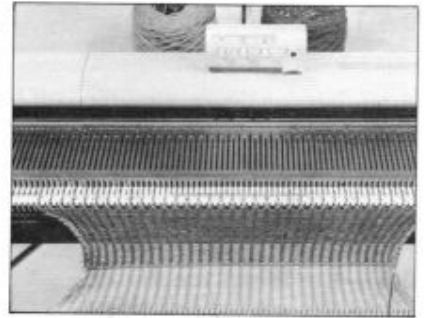

3. Knit with the waste yarn in the same way as for plain hem. Then knit one row with CAST-ON THREAD and change the yarn.

4. Knit the number of rows required for double the length of the hem in plain knitting with the yarn.



5. Bring forward the needles in position A to position B.

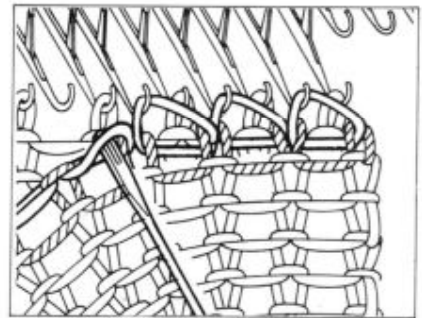

6. Pick up the stitches in the same way as for the plain hem and hook them onto the empty needles.

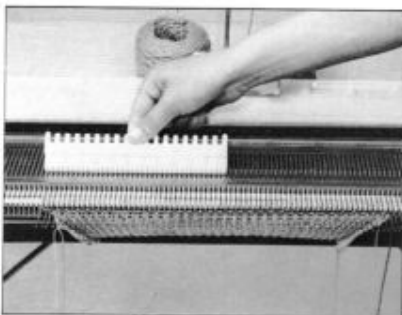

7. After picking up all the stitches, bring the needles to position E. Knit one row.



8. After knitting several rows, pull out the CAST-ON THREAD. The part knitted with the waste yarn is removed. Now 1 x 1 ELASTIC HEM is completed.



## 9-4. BINDING OFF AND BUTTON HOLE

### 9-4-1. Binding off using the tapestry needle

After finishing the knitting, bind off last row taking care not to unravel the knitting.

#### 9-4-1-1. When the yarn is on the left side

1. Pull the yarn out of the YARN FEEDER. Cut the yarn leaving a length of three times the width of the knitting.

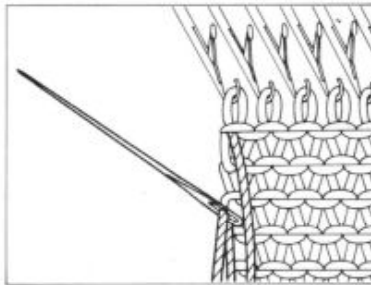

2. Thread the yarn into the TAPESTRY NEEDLE.

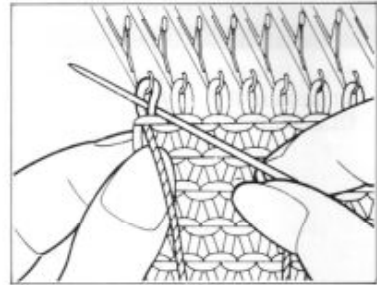

3. Pass the TAPESTRY NEEDLE through the left side stitch.

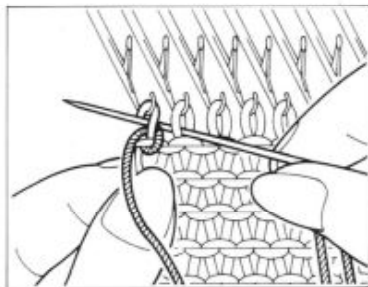

4. Insert the tapestry needle into the second stitch from left and pass it back through the left side stitch.

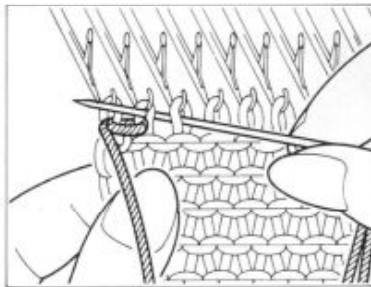

5. Insert the tapestry needle into the third stitch from left and pass it back through the second stitch from left.

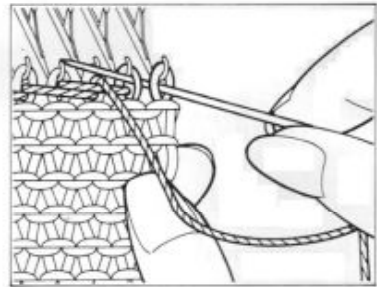

6. Repeat this until you reach to the right side of the knitting.

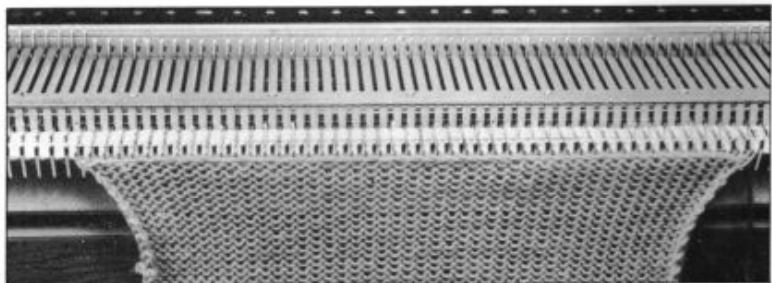

7. Now, the binding off is completed and piece can be removed from the machine.

9-4-1-2. When the yarn is on the right side

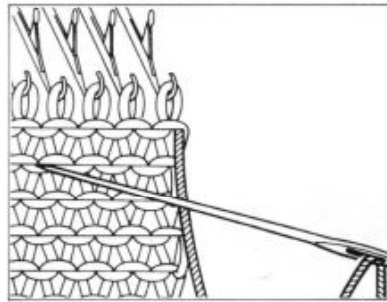

1. Pull the yarn out of the YARN-FEEDER. Cut the yarn leaving a length of three times the width of the knitting.
2. Thread the yarn into the TAPESTRY NEEDLE.

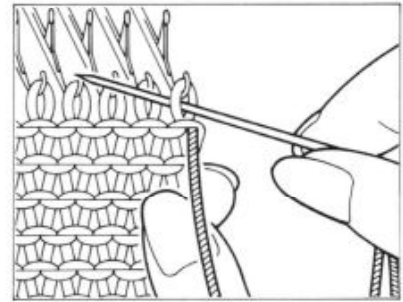

3. Pass the TAPESTRY NEEDLE through the right side stitch.

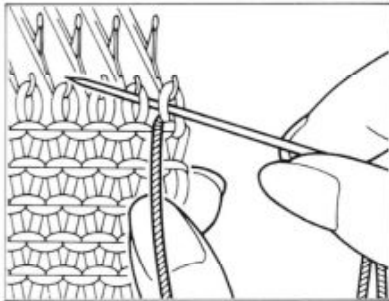

4. Insert the TAPESTRY NEEDLE into the right side stitch and pass it through the second stitch from right.

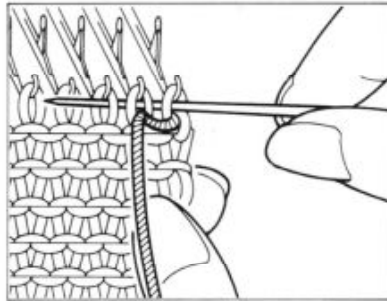

5. Insert the TAPESTRY NEEDLE into right side stitch and pass it through the third from right in the figure, making sure you pass the tapestry needle BEHIND the second stitch and enter the third stitch from behind.

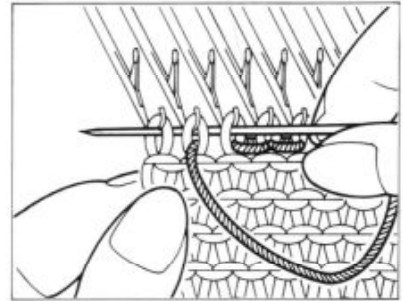

6. Repeat this until you reach the left side of the knitting.

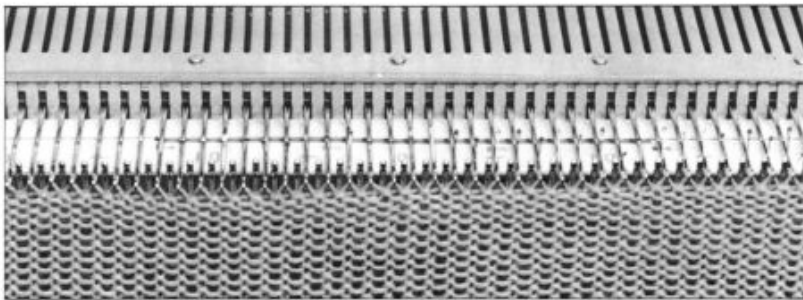

7. Now, the binding off is completed.



**9-4-2. Cast-off using the latch tool**

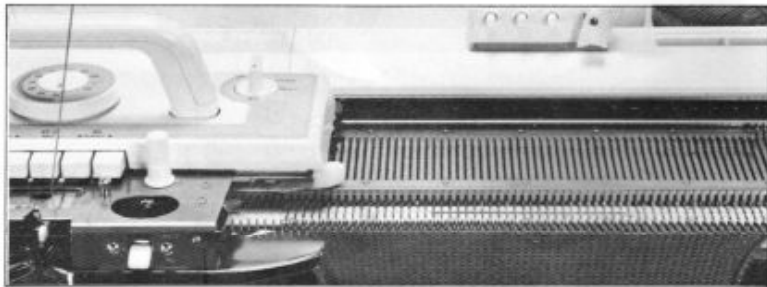

1. Loosen the TENSION DIAL and knit the last row. (For example, when knitting with tension dial number 4-6, set the number to 9-10.)
2. Place the K carriage on the left side of the machine.

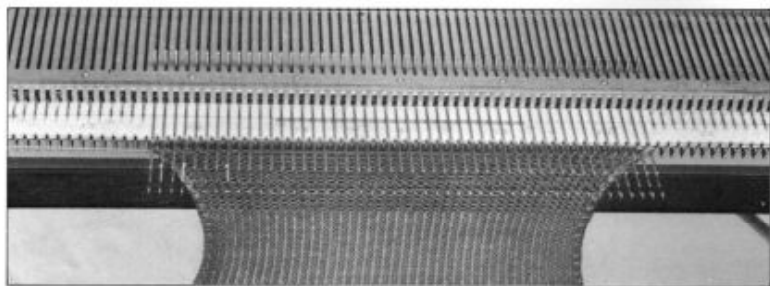

3. Bring the needles forward to position E.



4. Bring the knitting toward you taking care not to drop the stitches.

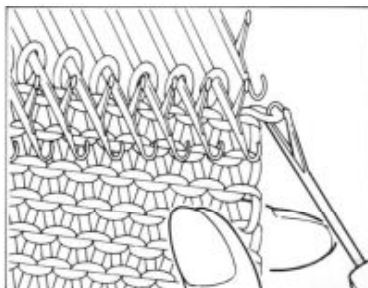

5. Hook the right side stitch on the hook of the LATCH TOOL.

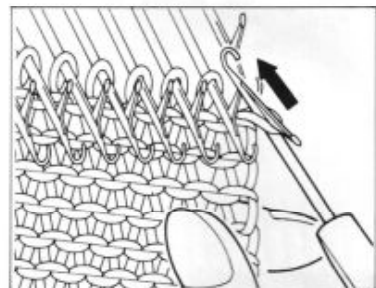

6. Make the stitch fall behind the latch of LATCH TOOL.

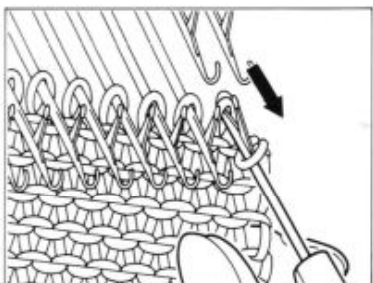

7. Then hook the second stitch from the right in the hook of the LATCH TOOL.

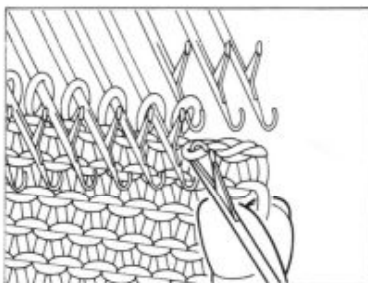

8. Pull the LATCH TOOL and make a new stitch (with the stitch over the latch and the stitch on the hook).

Take care not to drop the other stitches from the needles.

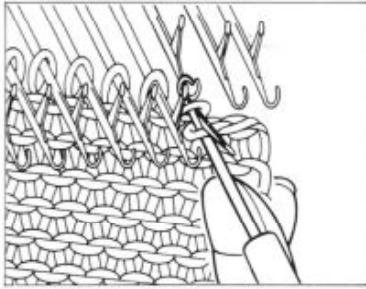

9. Make the new stitch fall behind the latch of LATCH TOOL, and hook the third stitch on the hook of the latch tool.

10. Repeat this until you reach the left side making new stitches across the row.

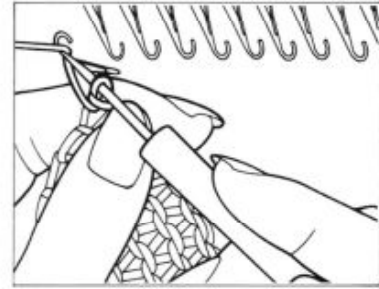

11. When you reach the last stitch, hook the end of the yarn on the hook of the LATCH TOOL and pull the end of the yarn through the stitch on the stem.

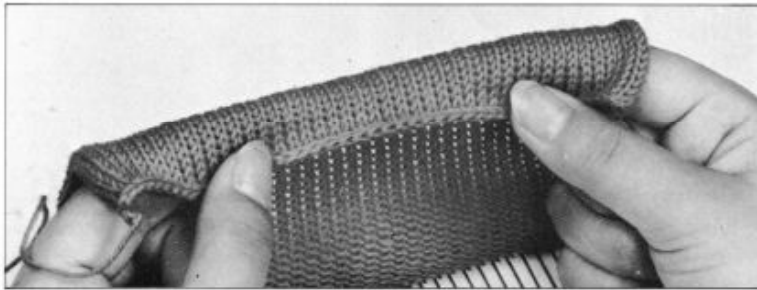

Now, the binding off is completed.

### 9-4-3. Vertical Seaming of plain stitch

1. Left hand piece – Pass the tapestry needle under threads of 1st and 2nd rows, bringing tapestry needle through to upper side.
2. Right hand piece – Pass the tapestry needle under threads of 2nd and 3rd rows, bringing tapestry needle through to upper side.
3. Left hand side – Pass the tapestry needle under threads of 3rd and 4th rows, bringing tapestry needle through to upper side.
4. Right hand side – Pass the tapestry needle under threads of 4th and 5th through to upper side.
5. Continue to seam in this way.

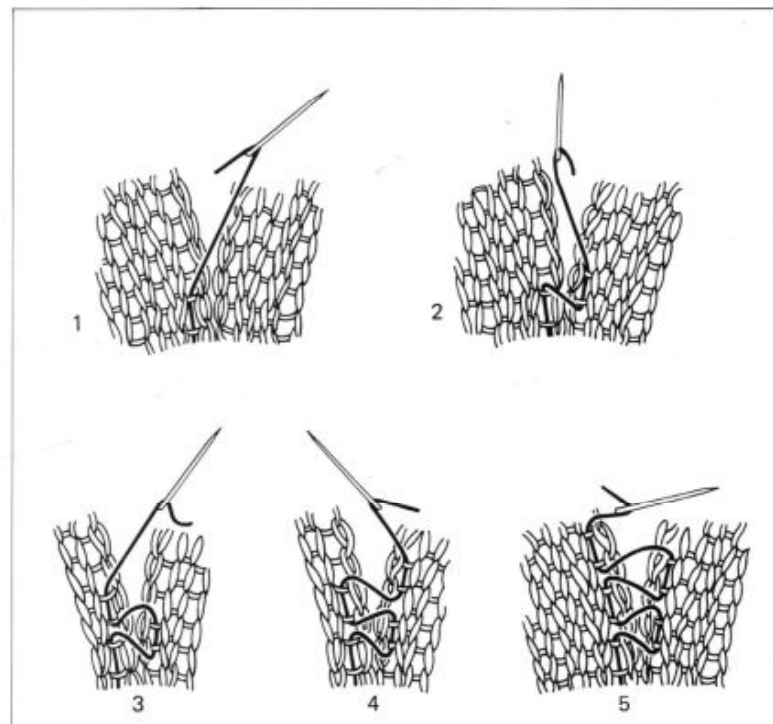

**9-4.4. How to make a button hole**

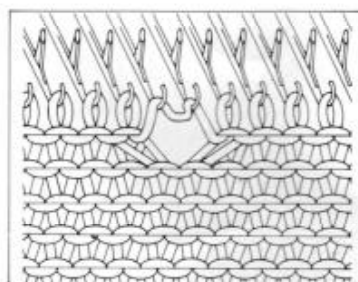
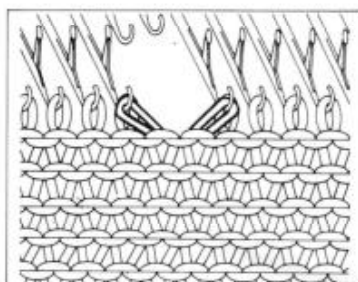

1. Using the 1 × 2 TRANSFER TOOL move the stitches, where you are going to make a button hole, to adjacent needles as shown in the figure.

2. Bring back the empty needles to position B, and knit one row. The yarn will hook on the two needles.

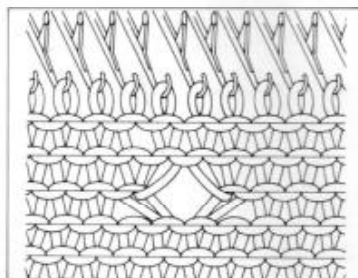
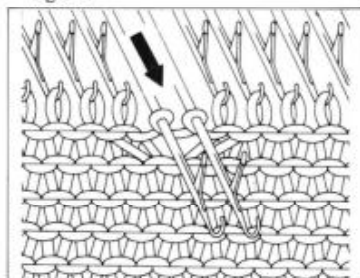
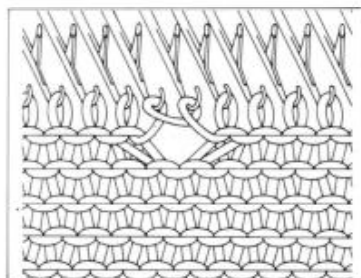

3. Loop the yarn around the two needles by hand as shown in the figure.

4. Bring the two looped needles forward to position E and operate the K CARRIAGE.

Then you have made a button hole.

## 9-5. HOW TO SHAPE A ROUND NECK LINE

### 9-5-1. Using the holding cam lever

#### 9-5-1-1. Plain knitting.

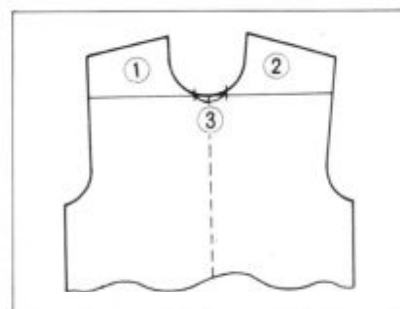

Knit the left and right side of the round neck line separately.



1. Set the HOLDING CAM LEVER of the K CARRIAGE to position H.

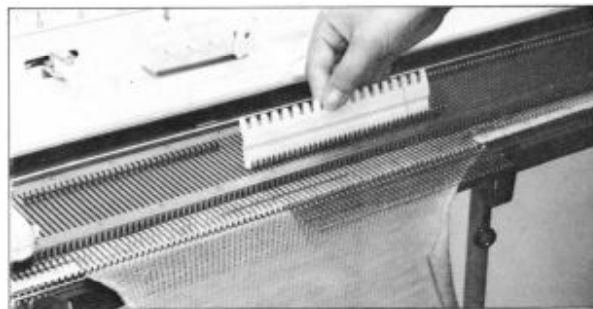

2. Bring forward to position E all the needles on the opposite side of the K CARRIAGE including the stitches for the center neck line and opposite shoulder. These needles will not knit.

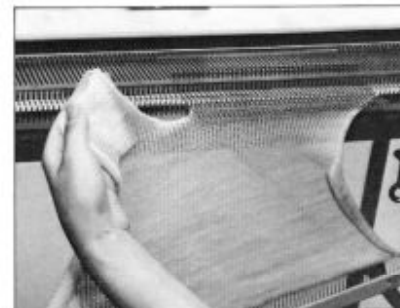
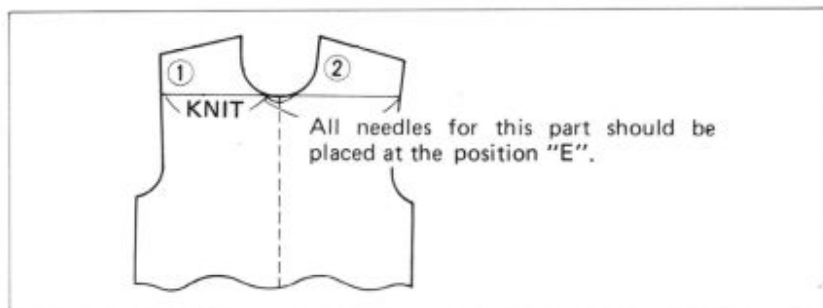

3. Knit part (1) according to your pattern. Decreasing at the neck edge will be done by using the Transfer Tool. Decrease in this manner until you have the required number of stitches left for the shoulder. Bind off the shoulder stitches.



4. Leaving the center neck line stitches, return the rest of the needles to position B by transferring the stitches onto the hooks of the needles. Knit the other side of the neck and shoulder for part (2).

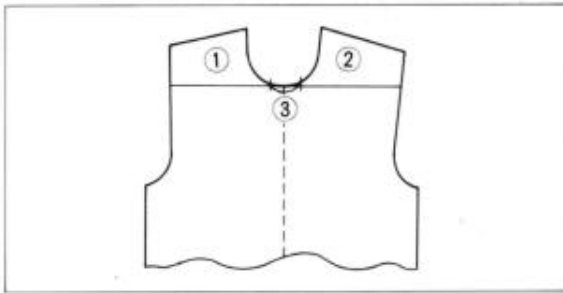

5. When parts (1) and (2) are completed, bring the needles for the neck line (3) to position B and bind off.

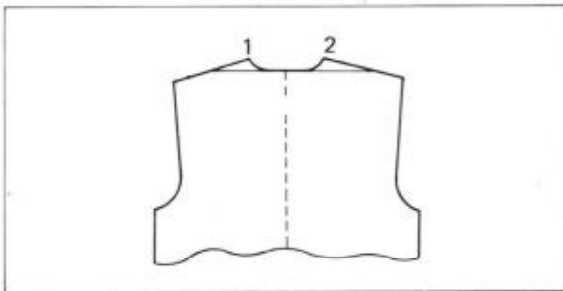

6. Knit the back in the same way. (Knit the left and right sides separately.)

### 9-5-1-2. Pattern knitting.

Knit the left and right side of a round neck line separately.

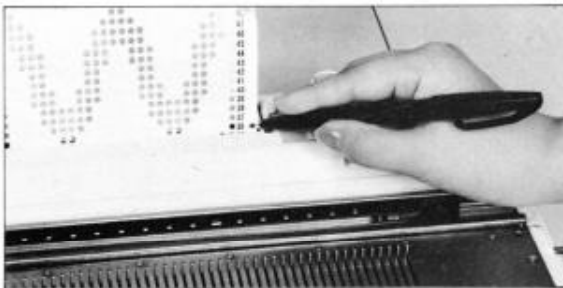
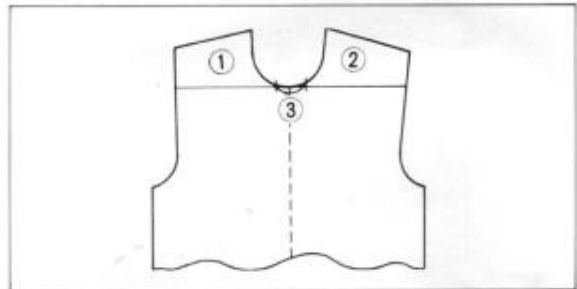

1. Knit one side in the same way as the plain knitting. Before you start knitting the first side, mark on the PUNCH CARD so that you can return to the exact row when you knit the other side.



2. After knitting the first side (1), knit the other side (2). Using a TRANSFER TOOL, place the stitches for part (2) onto the hooks of the needles and return to position B. Leave the needles for part (3) in position E.

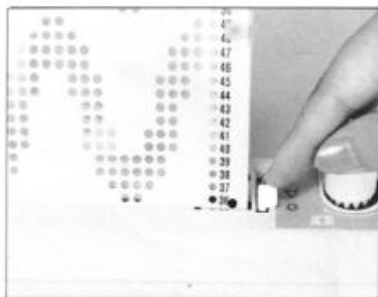

3. Return the PUNCH CARD to the mark on it and set the CARD LOCK LEVER to the "●" mark.



Push the CAM BUTTONS "PART".

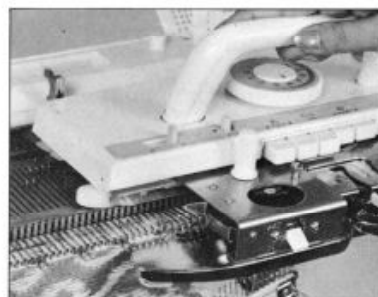

Operate the K CARRIAGE without threading the yarn into the YARN FEEDER. The needles are selected for the pattern. Make sure that the CHANGE KNOB is set to KC and that the HOLDING CAM LEVER to H.

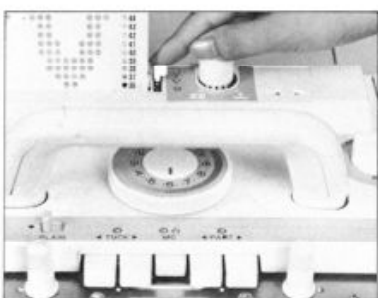

4. Set the CAM BUTTON according to the pattern knitting and also set the CARD LOCK LEVER to the "▼" mark.

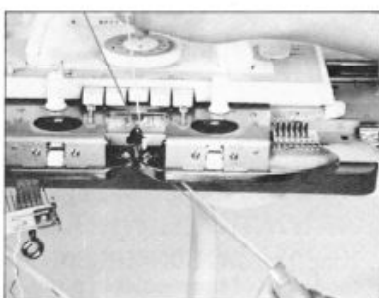

5. Thread the yarn into the YARN FEEDER "A" and knit the other side (2). For Fair-isle patterns or Weaving patterns, do not forget to thread the second color yarn into the YARN FEEDER.



6. When Parts (1) and (2) are completed, bring the needles for the neck-line (3) to the position B and bind off.

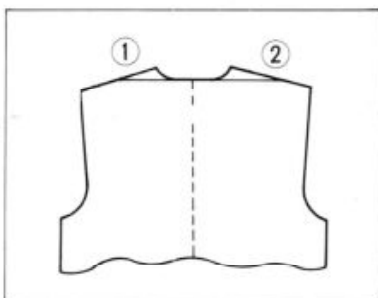

7. Knit the back in the same way. (Knit the left and right sides separately.)

**9-5-2. Using the cast-on thread**

**9-5-2-1. Plain knitting**

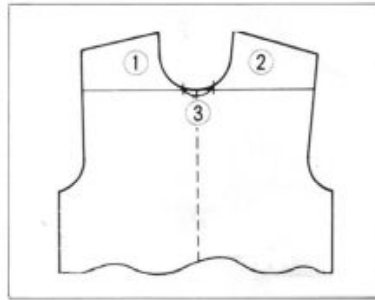

For shaping a round neck line, knit left and right side separately.

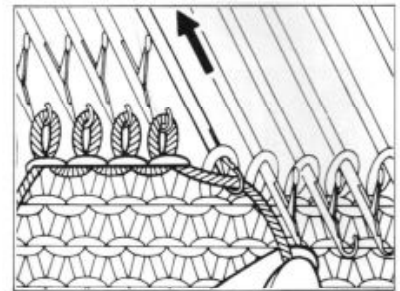
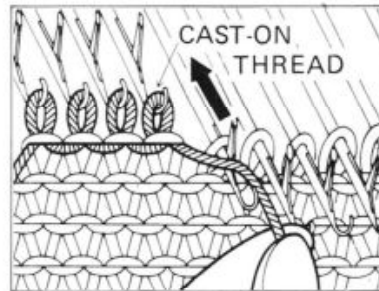

1. Bring forward to position E all the needles for the parts (2) and (3) on the opposite side of the K CARRIAGE, by using the 1/1 NEEDLE PUSHER. These needles will not knit.
2. Hang the CAST-ON THREAD on the hooks of the needles in position E and bring them back to position A one by one.

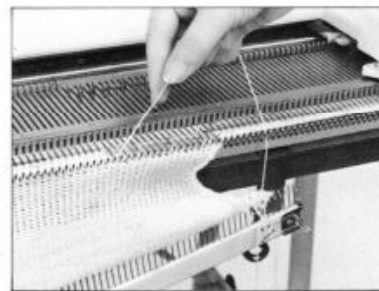
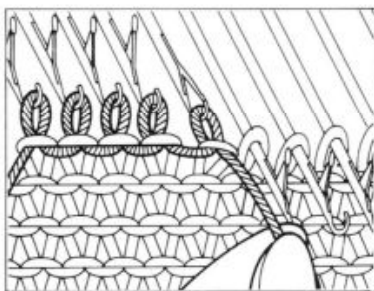

- At this time, make sure that the CAST-ON THREAD is between hook and latch of the needle to avoid dropping the stitches. Knit one side in the same way as instructed before.
3. When part (1) is completed, transfer the stitches for part (2) from needles in position A to the hooks of the needles and place them in position B.
- Leave the needles for part (3) as they stand.

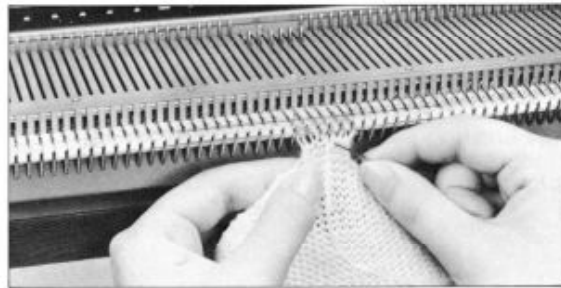
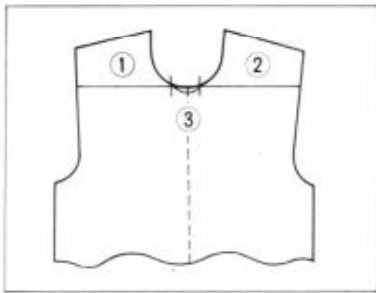

4. When parts (1) and (2) are completed, bring the needles for part (3) to position B and bind off.

5. Knit the back in the same way. (Knit left and right side separately).

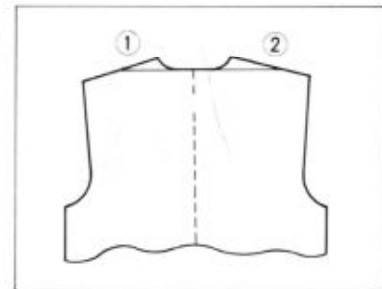

#### 9-5-2-2. Pattern Knitting.

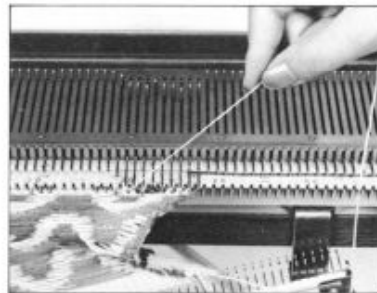
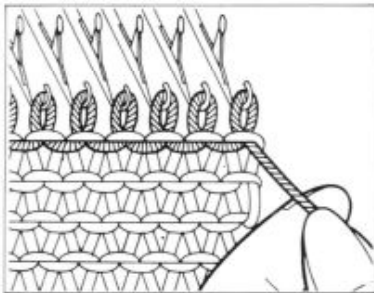

1. Bring back to position A all the needles for the part (2) and part (3) (opposite side of the K CARRIAGE) by using CAST-ON THREAD. These needles will not knit.

2. When part (1) is completed, transfer the stitches for part (2) from needles in position A to the hooks of the needles and place them to position B.

Leave the needles for the part (3) in "A" position.

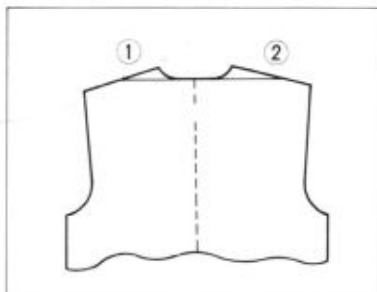

3. When parts (1) and (2) are completed, bring the needles for part (3) to position B and bind off.

4. Knit the back in the same way. (Knit the left and right sides separately.)



**9-6. SEWING PROCEDURE**

**9-6-1. Baste the knitting with binding wire and/or basting thread**

In order to produce a neat garment easily, it is recommendable to use a sewing machine for all necessary sewing.

As only straight stitch sewing is necessary, any type of sewing machine can be used.

Stretchy thread of the same color as the yarn used for knitting is most suitable for sewing (or, silk thread can be also used.)

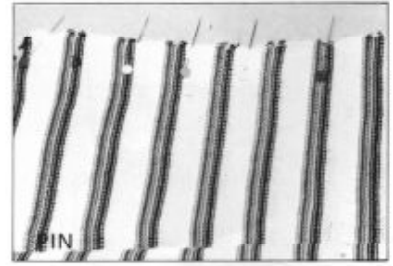

1. Pin the parts to be basted.

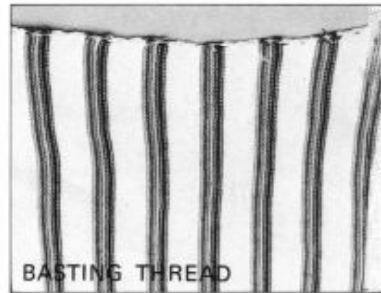
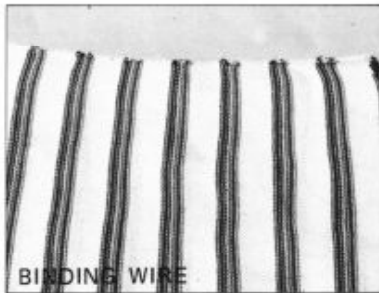

2. Baste the parts with the binding wire included with KL116 (Knit Leader) as accessory or basting thread.

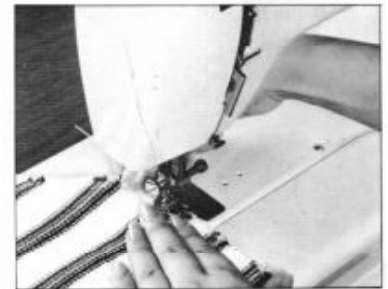

3. After basting, sew with a sewing machine. Slowly and naturally sew with a slight push along the basted edge, leaving a space of about 3-5 mm.

**9-6-2. Sewing procedure**

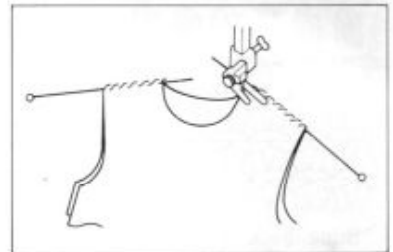

1. Shoulders (right and left)



2. Sides  
Sew hem or ribbing together by hand.

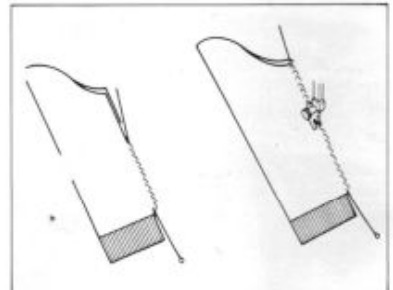

3. Sleeves  
Sew cuffs together by hand.

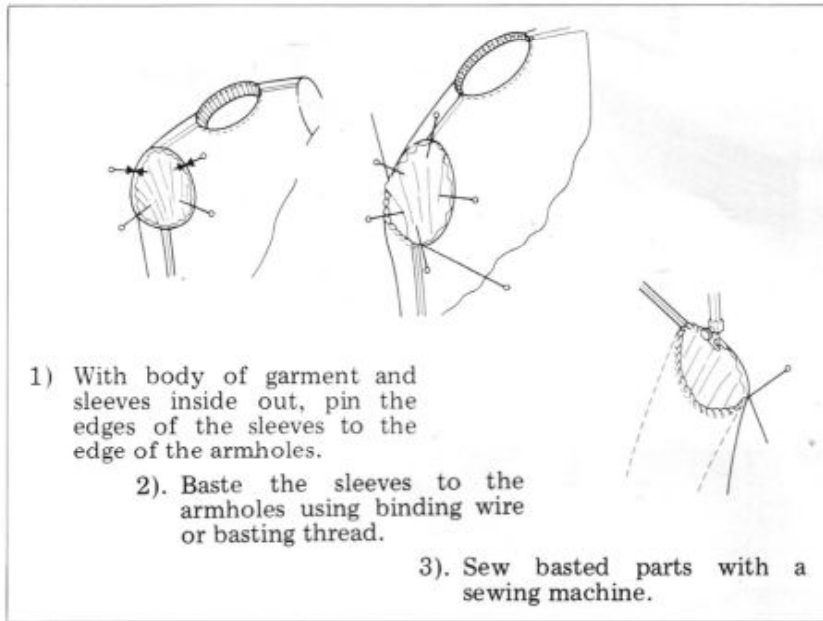

1) With body of garment and sleeves inside out, pin the edges of the sleeves to the edge of the armholes.

2). Baste the sleeves to the armholes using binding wire or basting thread.

3). Sew basted parts with a sewing machine.

4. Attach sleeves to armholes.

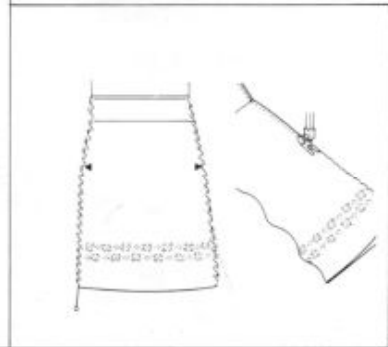

5. Skirt.

## 9-7. CLEANING AND MAINTENANCE

### 9-7-1. Replacing a needle

Needles with damaged latches will cause faulty knitting or dropped stitches and therefore must be changed.

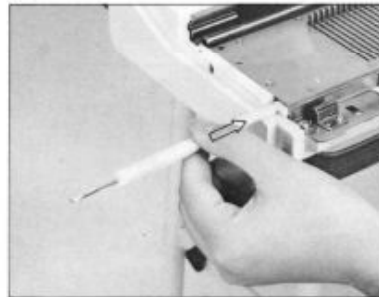

1. Push either side of the SPONGE BAR with the end of the LATCH TOOL until it comes out from the other end.

2. Draw it by hand from the knitter until the needle you wish to change is free.



3. Pull the needle forward as far as it will go. Push down the hook of the needle until shank end of the needle rises clear of the needle bed.

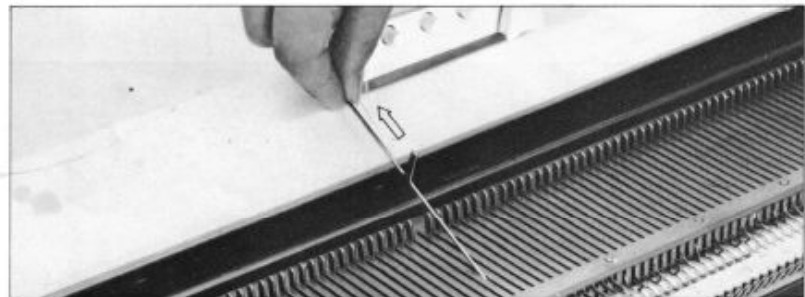

Grasp the shank end and take it out.



4. Replace it with a new needle by holding it with latch opened.



Push the Needle back to position A.

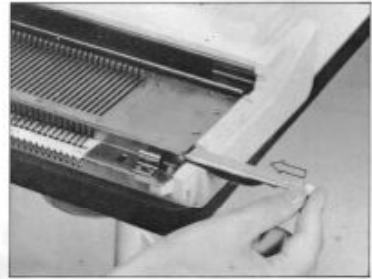

Push the SPONGE BAR back into place.

### 9-7-2. Cleaning and maintenance

Before folding up your machine, you should clean your machine with a soft dry cloth. The metal parts should be oiled regularly.

When you use your machine after it has not been in use for a long period, wipe your machine with oiled cloth and oil it before using. Before you start knitting, knit 20-30 rows with waste yarn to remove old oil.

Oil the following parts lightly before knitting.

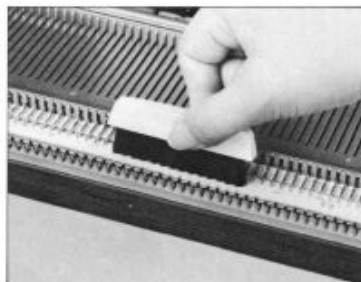

Butts of the Needles.

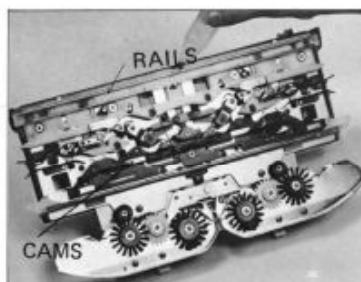

FRONT and REAR feet of the K CARRIAGE.  
CAMS.



Front and REAR RAILS of the needle bed.

## 10. USEFUL HINTS

### 10-1. PARTIAL KNITTING (Plain Knitting & Pattern Knitting)

When you knit socks, skirts, darts, etc., do partial knitting.

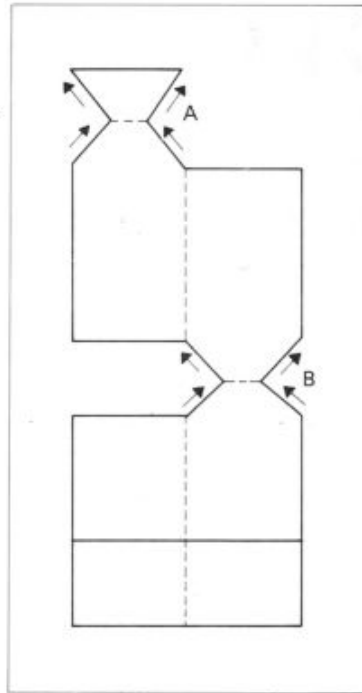

Socks.  
Knit the parts (A) and (B) with partial knitting.

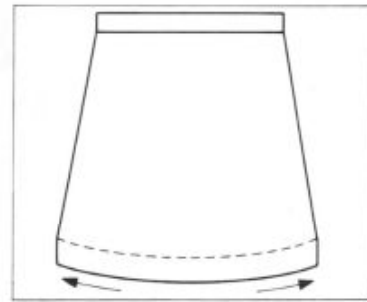

Skirt

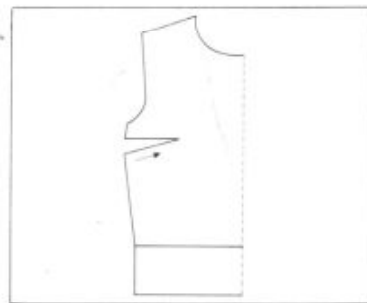

Dart

### 10-1-1. Decreasing stitches

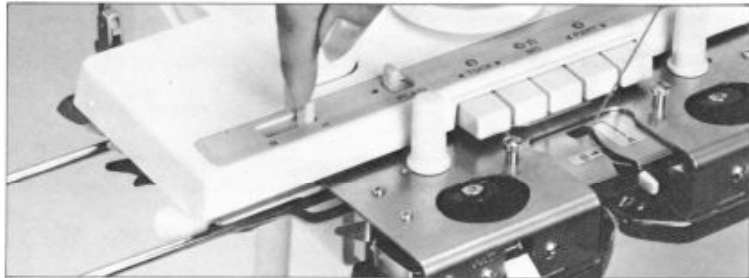

1. Set the HOLDING CAM LEVER of the K CARRIAGE to position H.

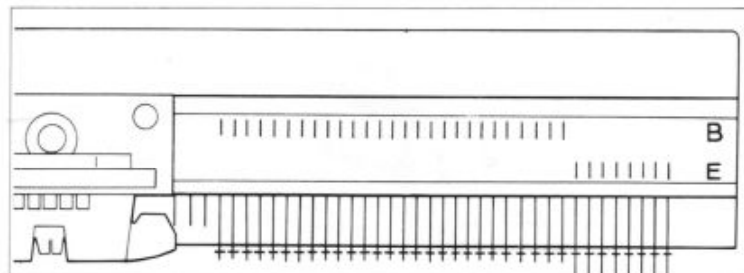

2. On the side opposite the K CARRIAGE, bring forward the needles which are to be decreased to position E as shown in the figure.

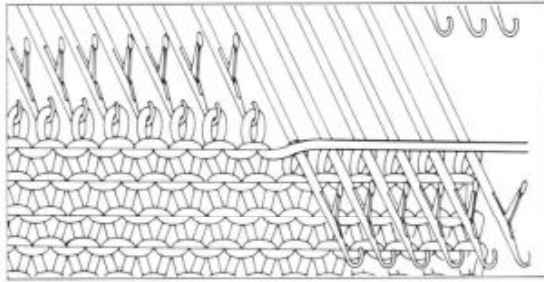

3. Knit one row.

4. When the stitches on the needles in position B are knitted, the yarn lies across on the stem of the needles in position E.

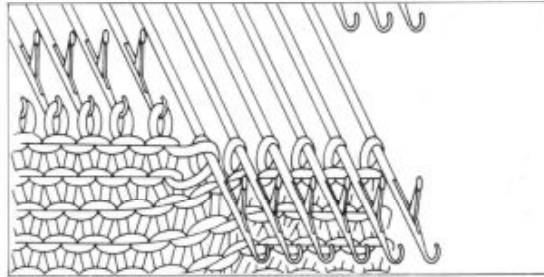

6. Knit one row making certain there is no slack in the yarn.

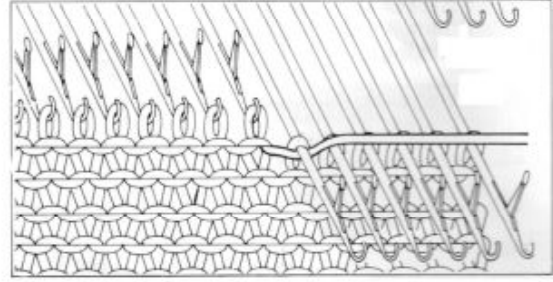

5. Pass the yarn under the stem of the first needle in position E. When knitting Fair-isle patterns or Weaving patterns, pass the second color yarn under the stem of the needle in the same way also.

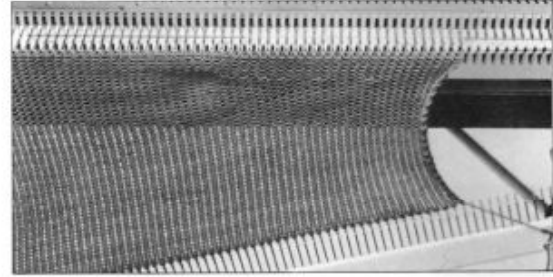

7. Repeat this procedure.  
Partial knitting is completed.

### 10-1-2. Increasing stitches.



1. Set the HOLDING CAM LEVER of the K CARRIAGE to position H.

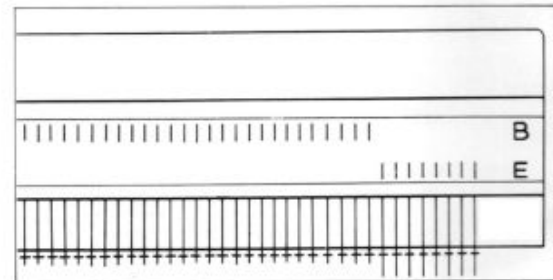

2. The needles which have been decreased are in position E on the side opposite the K CARRIAGE.

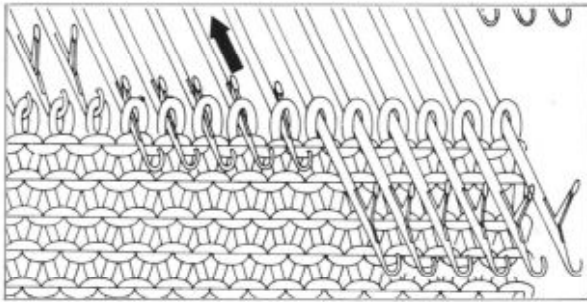

3. Manually move the needles for the number of stitches you want to increase from position E to position D. Take care not to drop the stitches.

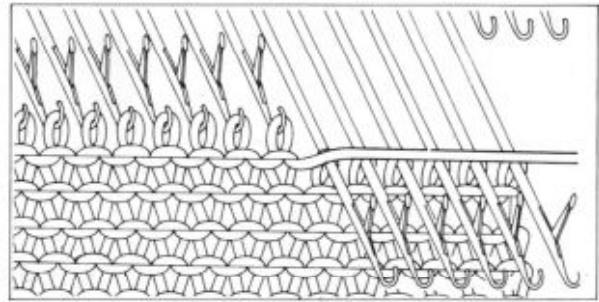

4. Knit one row. You will knit the needles in position D.

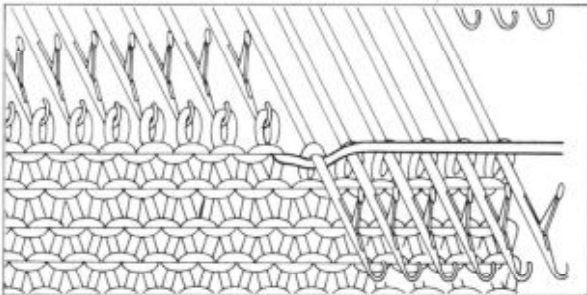

5. Pass the yarn under the stem of the first needle in position E.

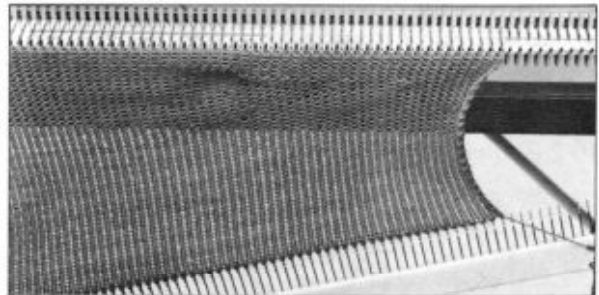

6. Repeat this procedure. You have increased stitches in partial knitting.

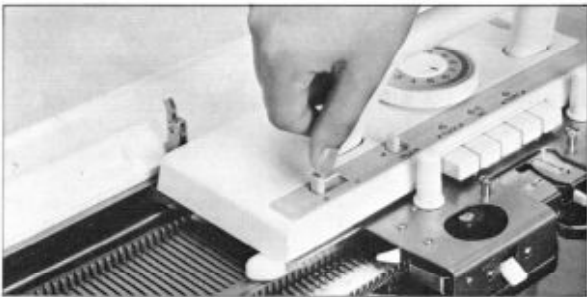

When partial knitting is completed return the **HOLDING CAM LEVER** to position N.

## 10-2. PARTIAL KNITTING (Lace Pattern Knitting)

### 10-2-1. Decreasing stitches.

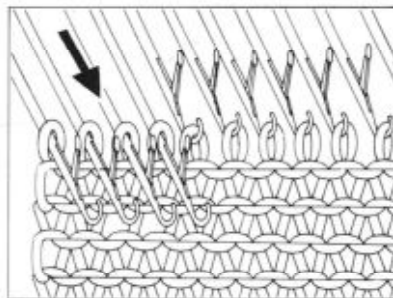

1. Bring forward the needles you want to decrease to position E.

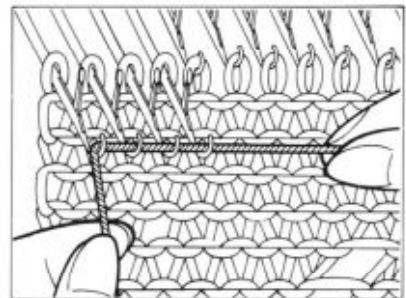

2. Lay the **CAST-ON THREAD** on the hook of the needles.

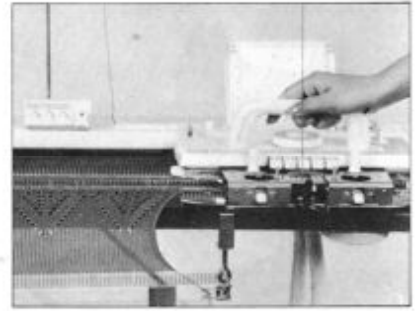
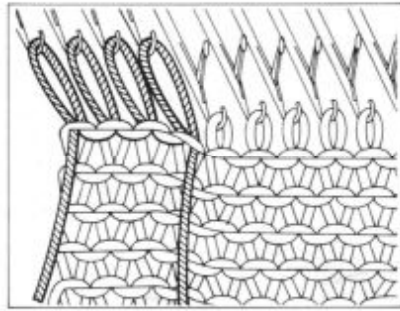
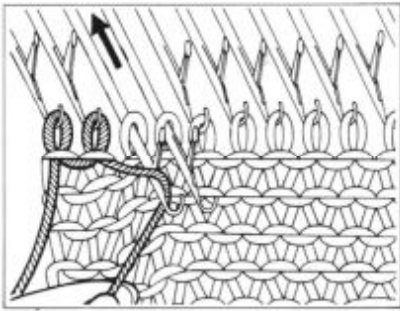

3. Make sure that the **CAST-ON THREAD** is in the hooks of the needles completely, and bring back the needles one by one to position A. At this time, take care not to drop the stitches.

4. Operate the **L CARRIAGE** and the **K CARRIAGE** according to the direction of the arrow on the punch card.

5. If you want to decrease more stitches, bring back the needles to position A in the same way.

### 10-2-2. Increasing stitches.

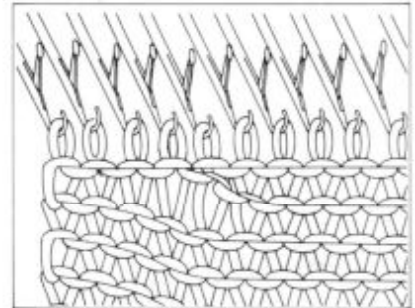
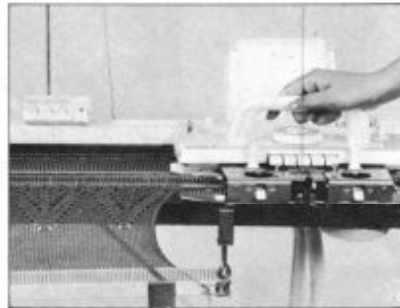
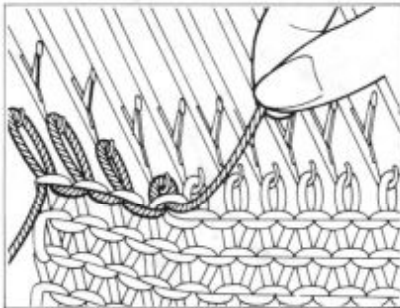

1. Pull up the **CAST-ON THREAD** slightly to remove it from the needles on position A, transferring the stitches to the hooks of the needles. Then place the needles to position B.

2. Operate the **L** and the **K** carriage according to the direction of the arrow on the punch card.

3. If you want to increase more stitches, transfer the stitches to the hooks of the needles in the same way and knit again.

You have increased stitches in partial knitting.