

ASSEMBLY OF WINDER UNIT

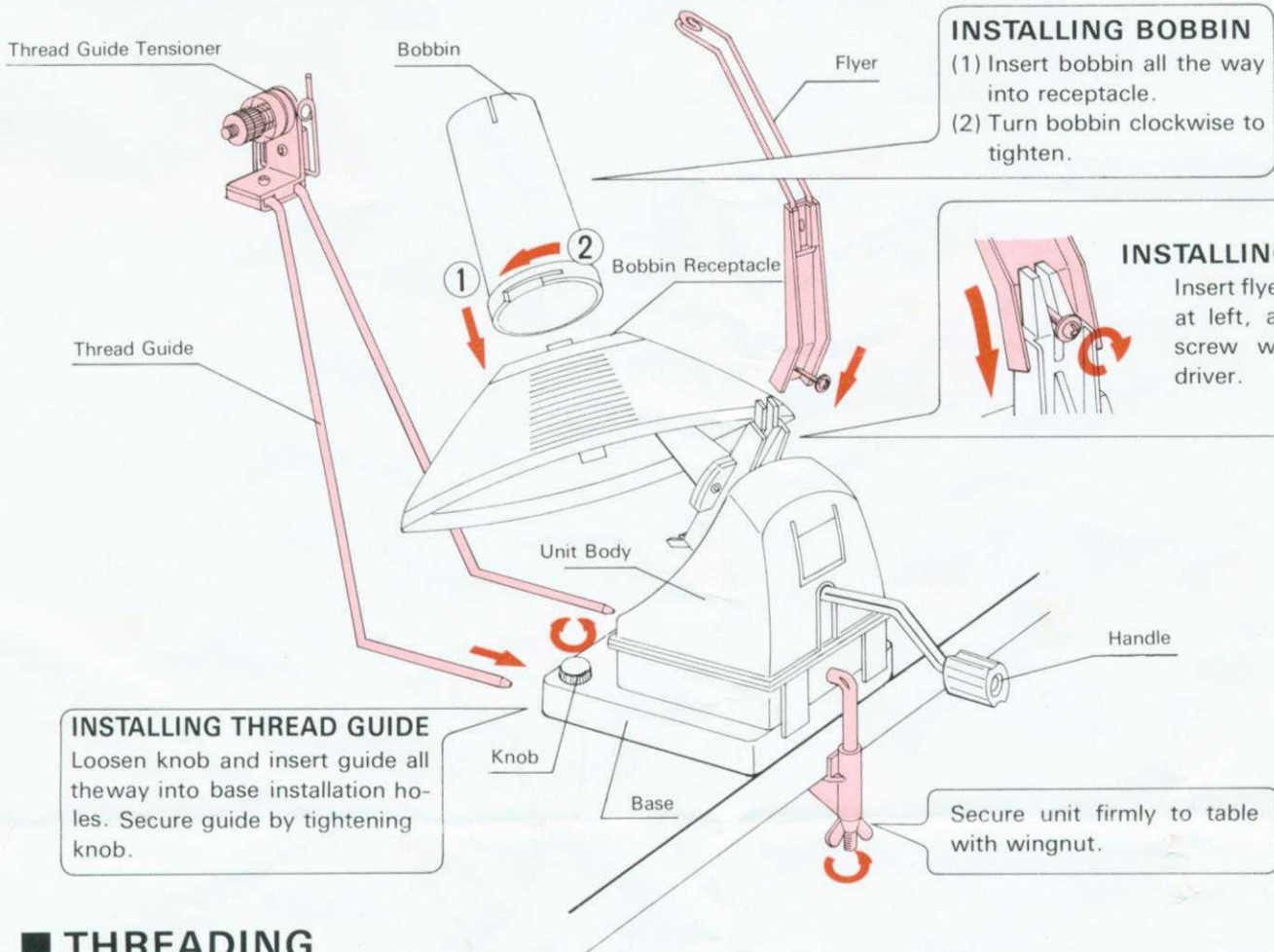

THREADING

