

Instructions for Operating
GEARHART'S
KNITTING MACHINE

Special Work and Family Outfit

AND ALL STANDARD MACHINES

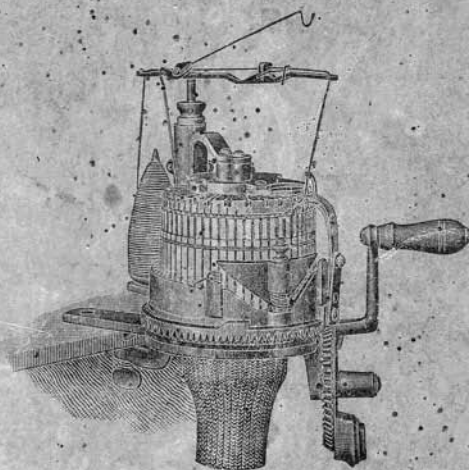

SOLD IN ALL COUNTRIES

NEW EDITION

ENTIRELY RE-WRITTEN

Price by Mail

50 Cents

GEARHART KNITTING MACHINE CO.
CLEARFIELD, PA., U. S. A.

STUDY THIS ILLUSTRATION

LEARN THE NAMES OF ALL PARTS

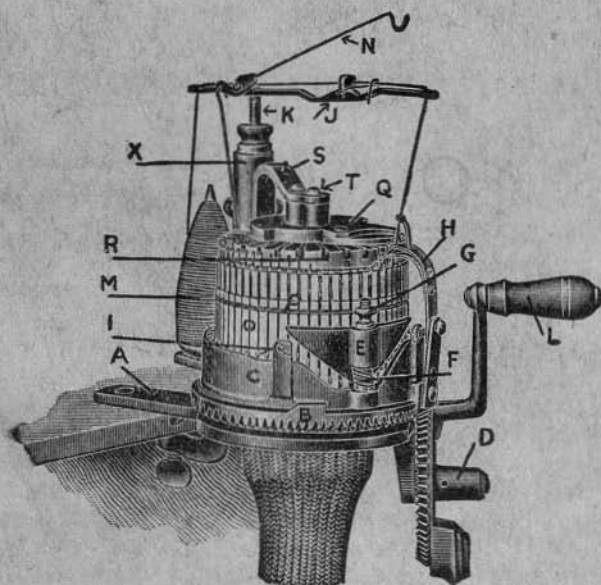

Model 1914-B and all "Standard" Machines.

A—Frame	B—Crown Wheel	C—Cam Ring
D—Gear Wheel	E—Cam	F—Cam Spring
G—Brass Cam Nut	H—Thread Carrier	I—Machine Latch
J—Yarn Guide	K—Guide Standard	L—Crank Handle
M—Yarn Bobbin	N—Take-up Spring	O—Cylinder
P—Needle Band	Q—Ribber Plate	R—Ribber Dial
S—Ribber Post	T—Any Screw	X—Gravity Weight

Read over the instructions carefully under each heading before attempting the work the heading implies.

The tension is set ready for learning. Learn *plain* knitting first. **Hold the work well down by hand** in addition to weights provided.

SECTION 1.
INSTRUCTIONS FOR USING.
THE GEARHART KNITTER

Read the First 4 Paragraphs before starting to Work the Machine and LEARN THE PLAIN KNITTING FIRST

1. UNPACKING MACHINE.—The greatest care must be exercised in doing this, so as not to damage any of the parts, particularly the needles, nor to disturb the work which is on the machine. A little care here will save you trouble later on.

(a) Remove the Machine from the box by taking out the cross piece and loosening the thumb screw which holds the machine to the bottom of the box. Fasten the Machine firmly to a solid support, a table, bench or window sill, by means of the clamp thumb screw.

(b) Put on the Gear wheel with the Crank handle up, and the Carrier directly in front of the Machine, as when unpacked, and is shown in illustration. The Gear wheel is held in position by the screw and washer at (D).

(c) Screw the upright Standard (K) for Yarn Guide into back part of Frame, Slip the wire loop first, then the Gravity Weight (X) down over the end of the Standard, and screw the Yarn Guide (J) on top the Standard so it will appear as shown in Fig. (1).

(d) Place the wooden Bobbin (M) with the yarn on the post at the back of the Machine. Don't use heavier yarn than that which comes with Machine. Pass the end of the yarn through the hole in the guide at (1). See Fig. (1). Through the hole at (2), under the wire loop at (3), down through the hole at (4). Leave the Take-up Spring (N), free; IT IS ONLY USED WHEN KNITTING BACKWARD AND FORWARD FOR HEEL AND TOE.

(e) See that a stitch is on each cylinder needle. If any have come off by accident, they should be replaced at once by means of the Work Hook or an extra needle. To knit THERE MUST BE A DISTINCT AND SEPARATE LOOP AROUND EACH NEEDLE,—always observe this. ONE loop must not be taken around TWO needles

2. IMPORTANT—EVERY MACHINE IS CAREFULLY TESTED BEFORE BEING SENT OUT, AND THE TENSION OR CAM (E) CORRECTLY SET FOR USING THE YARN SENT

WITH THE MACHINE. NO SCREWS, OR ADJUSTMENTS SHOULD THEREFORE BE ALTERED IN ANY WAY UNTIL THE ENTIRE WORKING OF THE MACHINE IS MASTERED. The learner will by that time understand the proper function of each part and can make any necessary alterations.

3. TO KNIT.—If all the stitches are on the hooks or needles, the yarn may now be joined to the end of the yarn hanging from the work on the Machine. MAKE AS FINE A KNOT AS POSSIBLE—the Square knot is best, and the ends of the yarn should not be cut close, but left long and knitted in. Take up any slackness in the yarn, by pulling it back to the bobbin; SEE THAT ALL NEEDLE LATCHES ARE DOWN (the needle latch is the small hinged tongue which closes on to the needle hook). Read carefully Page 10.

(a) Hang the weights on the SET-UP inside of Machine. ALWAYS ASSIST THE WEIGHTS BY PULLING THE WORK WELL DOWN WITH THE LEFT HAND SO THAT THE STITCHES DO NOT CREEP UP THE NEEDLES, but remain at the top of the Cylinder; and proceed to knit by turning forward the Crank Wheel (D). If the wheel sticks slightly at the start, as it may do sometimes after lying unused, a few smart taps on the handle in the direction in which the wheel should move will generally put matters right, and this is better than applying forcible pressure. Knit slowly when knot reaches the needle, and always knit carefully when passing knots in the yarn, through the machine.

If the details mentioned above have been carefully attended to, you should now be able to go on knitting without further trouble, any number of rounds of plain knitting.

4. IT IS OF UTMOST IMPORTANCE ALWAYS TO PULL THE WORK WELL DOWN WITH THE LEFT HAND, in addition to the weights, and to SEE THAT ALL NEEDLE LATCHES ARE DOWN BEFORE COMMENCING TO KNIT AT ANY TIME.

The Machine is quite automatic in it's action, and when the work is once started, the latches will look after themselves, but if either of the above principles are not observed, the needles may get damaged, and satisfactory work would be impossible.

After knitting a satisfactory number of rounds to gain confidence, watch the working of the Machine, so as to follow and understand the formation of the stitches.

WHENEVER YOU STOP KNITTING DO NOT LET THE YARN CARRIER MOVE BACKWARDS. Do not attempt to knit too quickly at first. In this, as in other things, speed will come by practice. NEVER run the machine fast when there is no work on the needles, as the latches may become damaged by striking the band or hooks catching in the carrier, and NEVER turn it backwards except when turning the heel and toe, or for flat web.

5. TO SET UP WORK ON MACHINE.—If the yarn is broken by you or accidentally breaks, the knitting will come off of the needles by turning the Crank wheel forward. **THREAD-UP MACHINE AS** shown in Fig. (1) and explained in (division-d-paragraph-1.) Pass the yarn through the loop (5) and through the hole in the point of the carrier (H). Draw about six feet of yarn through, or enough to set up the first round of stitches. Leave this loose end of yarn lie outside and down over the cylinder (O) toward the floor and to the right of the carrier (H).

(a) Place the Set-up inside of cylinder, see Fig. (1), and begin to set up the work to the right of the Carrier (H), around toward the back of cylinder, starting with the yarn just where it comes from the Carrier, and using it toward the end which hangs down on the floor. Now wind the yarn to the right around a Set-up hook and around the first needle, then around another hook and the next needle, crossing the yarn each time between the hook and the needle. There are less hooks in the Set up than there are needles in the Machine, therefore when necessary, use the same hook for the second needle too. Continue to set up in this way, winding to the right around the hooks and the needles, crossing the loop each time. After you have set up the work around the back part of the Machine and well forward to the front, it should appear as it is in the illustration. Fig. (1). **MAKE THE LOOPS VERY LOOSE.**

(b) After you have set up the Machine this far; hang the weights on the Set-up hook, inside of Machine—pull back to the Bobbin the slack yarn between the Yarn carrier (H) and the first needle, and between (5) and (4). **SEE THAT THE LATCHES ARE ALL DOWN**, then turn the Crank forward slowly until the Carrier (H) rests at back of Cylinder. Finish setting up on the remaining needles the same way and follow instructions (division-a, paragraph-3.) **READ CAREFULLY** paragraph (6).



Fig. 1

(c) In setting up the work, be sure to **CROSS THE YARN BETWEEN THE NEEDLES AND HOOKS**, as this makes the selvedge and prevents the top of the hose from raveling. **BEFORE BEGINNING TO KNIT—SEE THAT ALL NEEDLE LATCHES ARE DOWN, AND DO NOT FORGET TO PULL THE WORK DOWN.**

6. TO WIDEN AND NARROW THE KNITTING.—To **SHORTEN**, or **TIGHTEN**, stitches, Raise Cam (E) by turning to **LEFT** (that is unscrewing) Nut (G). For a **LONG** or **LOOSE** stitch, **SCREW** Nut (G) **DOWN**, by turning to the **RIGHT**. The Cam is only adjustable within certain limits, and on this account should not be altered until the learner is thoroughly familiar with the working of the Machine.

(a) Alterations on the Cam should generally be made gradually, turned just a little at a time, and a round knitted at each alteration; otherwise a great strain is placed upon the stitches, and the yarn may break.

(b) A thick or **HEAVY** yarn requires a loose stitch; while a tight or short stitch is more suitable for fine yarns. **NEVER HAVE THE STITCH SO SHORT AND SO TIGHT AROUND THE NEEDLE THAT YOU CANNOT KEEP THE KNITTING DOWN ON TOP OF THE CYLINDER**, where it has to be, by holding down on the work.

(c) Plain socks or stockings, should be shaped at the ankle by raising the Cam **VERY** gradually. **ALWAYS START THE HOSE WITH A LOOSE STITCH**, after the **SEAMED** or **RIBBED** top is made.

TO KNIT HOSIERY WITH SEAMED OR MOCK RIBBED TOP WITHOUT USING THE RIBBING ATTACHMENT.—Take every third or fourth needle out of the Machine, (raise the needle up until the shank or lower part strikes the Band (P), pull top forward then lift up and out from under band.) Set up as instructed in paragraph No. 5, (Making the loops around the Set-up and needles as tight as possible without breaking the yarn, as this is the completed selvedge top of the hose.) knit about 30 rounds with the Cam raised a little so as to make the knitting as close as possible.

(a) Put in the needles that were taken out, (you can get the shank of the needle under Band by pulling forward the next needle in Machine.) With your Work Hook or extra needle, take a stitch below and made by one of the adjoining needles, and place it over the needles just put in. They will then form their own stitches, if you begin to knit. If this stitch from below the adjoining needle is not lifted on there will be a little opening between the rib and the solid work.

(b) Lower the Cam, making a loose stitch, and knit about 80 rounds for the leg, narrowing as you come to the ankle by raising the Cam. You can practice doing this on a long strip of plain knitting

8. TO KNIT THE HEEL. (First Part)—Have the yarn carrier resting at the front of the Machine, and raise up out of action (Lift the needle up until it strikes the Band (P)—one half the needles in the Cylinder at the Back as shown in Fig. (2), Below. Now catch up

the yarn with the Take-up spring (N) and between (3) and (4). Place the brass Hold-down inside of the cylinder with the hook catching the stitches on the needles in action. Hang the weight on the wire loop of Hold-down inside of work. Now proceed to knit the heel as follows:—

Hold the work WELL down with the left hand resting on the Hold-down and knit one course to the right, taking Yarn Carrier well round to the back, making sure that the left latch (I) clears the last needle in

action. (A slight "click" will be sounded) Raise out of action this last needle down on the right, and knit one course to the left, again seeing that the latch clears last needle; raise out of action this last needle down on the left, knit one course to right, and so on, knitting backwards and forwards lifting the Hold-down every two courses and hooking onto the new stitches just formed. SEE THAT THE FIRST AND LAST STITCHES knit properly in each course. If they do not it is because the work is not being pulled down properly or that the yarn is not being held tight by the Take-up Spring. Continue raising one needle each course knitted always raising same on the nearest side of Yarn Carrier when course is finished, until only 12 needles are left in action. Always knit the last course to the right.

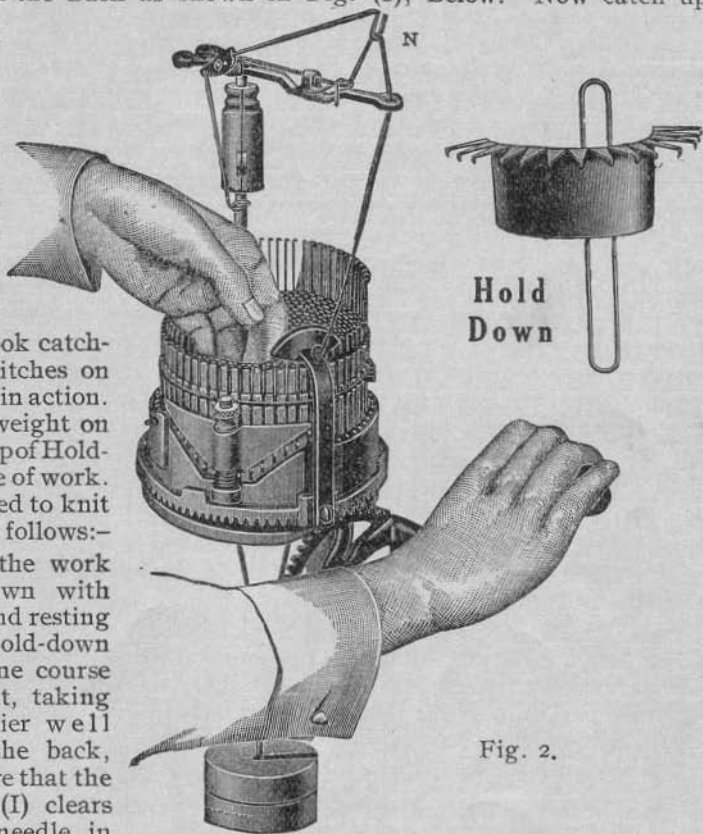

Fig. 2.

9. TO KNIT THE HEEL. (Second Part.) Fix the wire **HEELHOOK** with the weight attached, in the work as near the top as possible, one hook at each end of the twelve stitches; press down into action one needle, on the opposite side from which you raised the needle while knitting the first part, and is the needle farthest away from the Yarn Carrier when you finish each course. Knit backward and forward, pressing down a needle each time until all the needles are down that were raised in the first part, **EXCEPT THE LAST ONE ON EACH SIDE**, which prevents a hole appearing in the finished work.

BE CAREFUL THAT ALL NEEDLE LATCHES ARE DOWN AND THE YARN HELD UP TIGHTLY BY SPRING (N) SO THAT EACH NEEDLE CATCHES THE YARN AS IT COMES FROM THE CARRIER TO FORM A GOOD STITCH. KNIT SLOWLY AND WATCH CAREFULLY THE FIRST AND LAST STITCHES MADE IN EACH COURSE HOLDING DOWN ON THE WORK WITH THE HEEL HOOKS AND TAKING A NEW HOLD WITH THEM EVERY TWO COURSES UP CLOSE TO THE FIRST NEEDLES ON EACH SIDE WHICH ARE KNITTING AND HOLD DOWN WITH YOUR FINGERS ALSO AS SHOWN IN FIG. (2).

When finishing the heel, do not complete the last course, but stop with the Yarn Carrier in front of the Machine, as in Fig. (2), in a position to turn forward. Push down into action, all of the needles in the Cylinder including the two above mentioned. Take the yarn off the Take-up Spring (N), see that all latches are down and you are then ready for the foot.

REMEMBER when knitting the heel and toe, to always in the (first part), raise the needles on the same side of the Machine that the Carrier stands; and in the (second part), to push them down on the opposite side of Machine from the Carrier—**OTHERWISE** you will cause holes where the heel joins at the points.

10. TO KNIT THE FOOT. If the Take-up Spring is free and the needle latches are all down, you knit forward as you do in knitting the leg of hose. Catch the heel just knit and the other part of the hose **FIRMLY** with the left hand and **HOLD DOWN** on the work sufficiently to keep the stitches from raising with the needles. Do not use the Hold down or the Heel hooks for this part unless you can do it to better advantage.

The foot should be knit with a tighter stitch than the leg to make it the required size, by adjusting Cam (E), but not so tight that the needles won't work easily. After you knit about sixty rounds or any required length, you are ready to knit the toe.

11. TO KNIT THE TOE. The toe is knit by the same process that you knit the heel and on the same side of the Cylinder, with just half of the needles in action. as before.

Use the Take-up Spring (N), see that the latches in all needles are down, the Cam plenty low enough, the Yarn Carrier in front part of machine as Fig. (2), hold down the work well with the Hold down furnished, and knit forward and backward, pulling up a needle each time nearest the Yarn Carrier, to twelve needles, in the (first part). The (second part), knit forward and backward pushing down in action every course, the needle farthest away from the Yarn Carrier, the only difference is, in knitting the toe you place in action and use the last needle on either side which you were instructed to leave standing in completing the heel. Do not finish the last course until you put all the needles in the Cylinder down in action. Now knit about **FOUR ROUNDS OF WORK LOOSE** and with the Take-up Spring free, break the yarn near the Carrier and turn Crank slowly forward, causing the work to come off the machine.

If you have carefully followed these instructions and you are not using yarn which is too heavy, you will have a completed sock or stocking, which cannot be better made. The toe is closed up by hand.

12. TO CLOSE UP THE TOE. When the Sock or Stocking is taken out of the Machine, the toe should be laid flat and pressed

under a damp cloth with a hot iron. This makes the stitches flat and firm, and prevents their running down. Unravel exactly the number of extra rounds knitted; it will be observed that a small hole appears in the knitting at each side of the row where the actual finish took place, and this is the point to ravel back to, which is shown in Fig. (3), and study carefully.



Fig. 3

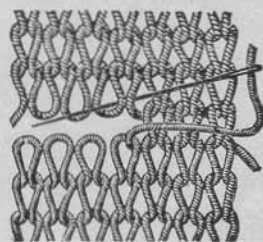

Fig. 4.

join up the stitches as follows:—

(a) EACH stitch, it will be noticed in Fig (4) has the needle passed through it **TWICE**, thus: put the needle **IN** through the first stitch and **OUT** through the second one **ON THE SAME SIDE**; then **IN** through the first one **OUT** through the second one on the opposite side and so on, as illustrated, until the opening is closed.

This joining up of the toe is very simple if instructions are followed and the illustrations is closely studied, and if properly done, it is a regular stitch like the rest and cannot be noticed from remainder

of the knitting. It should be done loosely and the same tension as that of the knitting itself. The number of rows raveled out should be exactly the number of extra rows knitted.

13. TO REINFORCE THE HEEL AND TOE WITH SPECIAL YARN. We furnish a SPECIAL MERCERIZED COTTON for this purpose and should be used to make the best wearing grade of hosiery.

Place the cone of Special RE-ENFORCING yarn in a position back of Machine that it will wind off FREELY. Thread this through the second eye in the back of Yarn Guide and tie on to the regular yarn you are knitting with just as you start knitting the heel, and break off again when you are through with the heel BEFORE knitting the foot. To re-enforce the toe or any other part, follow the same process, noting that Cam has to be lowered a little when this special yarn is added.

14. TO KNIT LONG STOCKINGS. You do not take out any of the needles in knitting stockings but set up with the full set of needles. Knit the top a little loose so as to give the required size. Knit from 60 to 100 rounds and then shorten the stitch a very little, knit 10 to 15 rounds and again shorten; knit the length required, say 130 or 140 rounds. Knit heel and complete same as for sock. If a measure is preferred, it takes about 24 inches before shortening the stitch, and 6 or 7 for ankle after tightening.

15. ANOTHER WAY TO NARROW ANKLE. Knit 60 to 100 rounds, take out one needle in the centre of the cylinder at the back; knit 2 or 3 rounds; take out the fourth needle on each side of the first one taken out. Continue to knit two rounds, removing the fourth needle on each side until every fourth needle is removed. Knit 30 to 50 rounds and put in the needles taken out in front where the heel is knit; knit the heel; knit the length required for the foot; put in the rest of the needles taken out; knit three rounds, and knit toe as in other cases. If taking out every fourth needle makes the ankle too small only remove them from the back half of the CYLINDER; this makes the seam on y in front of the stocking.

16. TO KNIT CHILDREN'S OR SMALL SIZED HOSE. To knit small sizes you should use either the special cylinders, No. 54, (which uses the same gauge needles as the No. 72), or the No. 52, (which uses the same gauge needles as the No. 60.) Upon these two special Cylinders you knit the small sizes by the same processes that

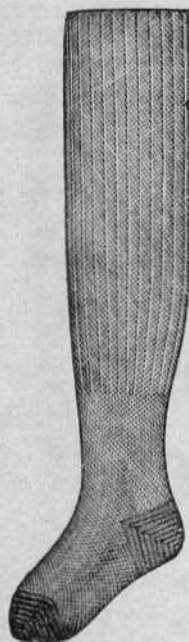

Fig. 5.

you have just passed over, observing the following instructions and using the same grades of yarn;—Make a loose stitch with the Cam low and hold down on work when you use the heavier yarn, and for medium grades, knit the work with a medium tension, holding down on the knitting very hard.

FOR BOYS HEAVYWARE, Knit the leg all or part ribbed, on the Cylinder for large sizes and the Ribber, then join this long section on one of the above Cylinders and finish the heel, toe and foot, re-enforcing the heel and toe, and surely you cannot find a better wearing stocking. Also knit plain with wide hem covering knee.

By taking out every second or third needle in the No. 72, No. 60, or No. 100 Cylinder you can also knit the smaller sizes, but you will not obtain the best results; as with the No. 54 or No. 52 Cylinders

17. TO OIL MACHINE. Do not oil too freely but keep enough on the Machine to lubricate the moving parts that they will run easily. Oil the needles in the grooves and the Cam frequently. Never use anything but the best of Machine Oil, which can be bought from us.

18. TO CHANGE CYLINDERS. Loosen the screws which hold the Cylinder to the Frame at the bottom of the Cylinder underneath the Machine. Always fix the No. 72 and No. 60 Cylinders in the Machine with the lug in the Cylinder at the BACK of Machine.

19. DAMAGED NEEDLES. If the latches on the needles become bent in operation, straighten them with the fingers. It is very necessary to have all latches and the needles work free and easy, or you cannot do good work. Don't use the needles if they are rusty.

20. TO WIND THE BOBBINS. It takes but a moment's time to wind the Bobbins with our NEW BOBBIN WINDER and SWIFT. Clamp both the Winder and the Swift on a table or bench about three feet apart, placing the Swift arms and pins in position with the yarn drawn on them that it will wind off freely. Wind on the Bobbin with a "zig zag" motion starting at the big end, and as you fill it work toward the small end. The yarn must be made to wind off very freely and all yarn must be smooth and even with the knots tied small.

Large Bobbins can be obtained for 30 cents each by mail. Enough yarn can be wound on them to knit about two pair of hose and the Bobbin set on the floor or table, so the yarn winds off freely. To make extremely heavy knitting for certain requirements, two or more strands of yarn from different Bobbins can be knit at the same time being careful to adjust the Cam (E) loose enough that it will knit easily. By knitting two different colors at the same time, very pretty patterns can be effected.

Important Points to be Observed

(a) Always read through Carefully, the Instruction as given under each head, before attempting to do the work the heading implies.

(b) Be sure the yarn you are using is not too heavy for the cylinder and needles you are using it on.

(c) In practicing any new stitch or new part, always knit with a loose stitch and the cam low.

(d) At all times see that the Needle Latches are all down that the Needle Hook will easily grasp the yarn as it leaves the Carrier. The Carrier is adjustable so that it can be made to lead the yarn to the hooks correctly. See that this is done.

(e) No needle will make a correct stitch if the work on the Machine is not held down close to the top of the cylinder.

(f) Always remember that in knitting forward the needles must run up over the right latch and out under the left latch. In backward, run up over the left latch and out under the right.

(g) Oil the Ribber and the Machine frequently and take care that the needles do not become rusted.



SECTION II.

HOW TO ADJUST AND USE THE RIBBING ATTACHMENT.

Do NOT Undertake to Use the Ribber Until You Have First Learned to Knit the Plain Work and Thoroughly Understand the Machine.

READ THESE INSTRUCTIONS ALL OVER CAREFULLY AND STUDY THE ILLUSTRATION FIGURE 6, BEFORE USING RIBBER.

The Ribber Dial Carrying 36 Needles, Works on the No. 72 Cylinder.
The Ribber Dial Carrying 30 Needles, Works on the No. 60 Cylinder.

21. TO FIX THE RIBBING ATTACHMENT FOR KNITTING. Remove all needles from the Dial (R). This has already been done when the Machine was packed up at the factory, and the Ribber needles with the screw for fastening the Ribber on the Machine placed in a small envelope with extra Cylinder needles and sent with the Machine. The Dial is the circular disc or plate with grooves in, forming a part of the Ribbing Attachment.) Have all the work off the Machine and all the needles in the Cylinder. Place the Ribber on the Machine as shown in Fig. (6), fitting the **Ribber Post (S)** into the **Socket** at the back of the **Cam-Ring (C)** and with the Ribber dial Directly over the center of the Cylinder. Force the Ribber Post (S) down into the Socket as far as the Guide Pin, to the left of the Socket, will allow; **HAVING THE BOTTOM OF THE DIAL (R) JUST A LITTLE ABOVE THE TOP OF THE CYLINDER**, to permit space enough for the knitting to pass down between.

(b) Turn the crank forward until the **PIN** on the under side of Dial rests to the right against the **LUG** inside of Cylinder at the back. **THIS IS THE POSITION THE RIBBER SHOULD ALWAYS BE IN WHEN KNITTING WITH IT.** Now take out of the Cylinder, the needles which are **DIRECTLY IN FRONT** of the needle grooves in the Dial, place the Ribber needles in the Ribber Dial, this is done by turning the Crank forward so the Ribber plate (**Q**) will allow the needles to enter). Turn the Machine forward a few times to see the working principle and you are ready to knit with it.

22. TO KNIT WITH THE RIBBER. After it is properly adjusted, lift the Ribber with the

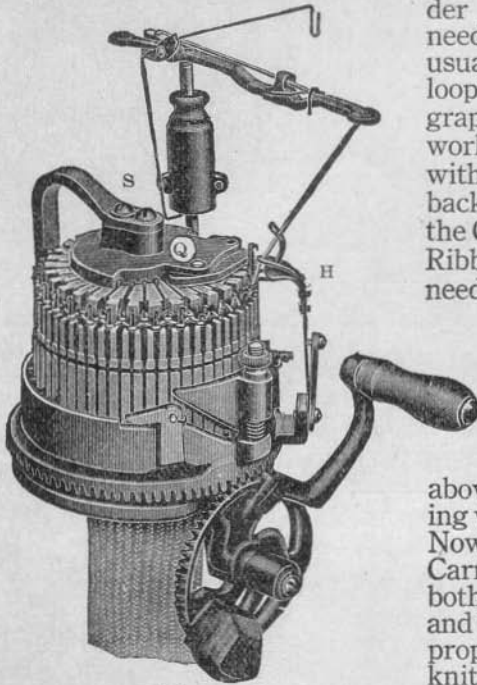

Figure 6.

needles still in, out of the Cylinder and set up work on the needles left in the Cylinder in the usual way, being sure there is a loop on every needle. (See Paragraph 5). Knit ten rounds of the work on the Machine and stop with the Carrier resting at the back, and the SOCKET on the Cam Ring in front. Place the Ribbing Attachment without the needles in the Dial, on the Machine, as instructed in Paragraph 21, having the PIN on the Dial resting back of the Lug to the right, inside of the Cylinder and the Dial suspended just high enough above the Cylinder that the knitting will easily pass down between. Now take up the slack yarn at Carrier, and if all needle latches both in Dial and Cylinder are open and by holding down on the work properly, you should be able to knit. SEE FIG. (6). ALWAYS KNIT THE RIBBED WORK WITH A LOOSE STITCH AND

KNIT SLOWLY WATCHING YOUR RIBBER NEEDLES WORK. ALWAYS HOLD DOWN EVENLY THE WORK WITH YOUR HAND WHEN USING THE RIBBER, ESPECIALLY UNDER THE LUG AND PIN.

23. TO KNIT THE SELVEDGE RIBBED TOP FOR HOSIERY, Using the Tappet Lever as shown in Fig. (7). This makes the ribbed top even and pliable. After you have accomplished knitting the plain ribbed work as instructed in (par. 22)

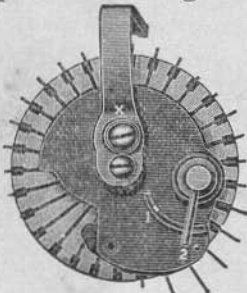

Fig. 7

and with the work still on the Machine and Ribber; (a)—Break off at the Bobbin, the yarn you are using and tie on to it some ordinary or different colored yarn and knit with it about 5 rounds. This different yarn is used so that afterward you will easily see where the selvedge top begins. (b)—Break at the Bobbin and join on again the regular yarn and knit with it just one complete round, carefully watching it as it enters the Machine and that each Ribber needle takes it, as it leaves the Carrier, and sheds the last stitch made with

the ordinary yarn. (c)—Swing the Tappet Fig. (7) to position (1) which puts the Ribber needles OUT OF USE and knit TWO or THREE rounds only, firmly holding down on the knitting. (d)—Swing the Tappet Lever back to position (2), which puts the Ribber needles IN USE again, and then continue knitting to the required length you wish the ribbed top, usually 30 rounds. (If the Tappet Lever sticks, in swinging it, turn the Crank forward a little.) You are now ready to take off the Ribber and continue knitting the leg.

24. TO TAKE THE RIBBING ATTACHMENT OFF THE MACHINE. Transfer the stitches on the Ribber needles, one at a time, to the Cylinder needles you will put back in the Cylinder in the empty grooves; pulling the Ribber needle forward until it clears the Ribber Plate (Q) being careful the stitch does not pass back and off the Ribber needle Latch. The Crank is turned forward as desired to clear the Ribber needles from under the Ribber Cam, until all stitches are transferred and the Ribber free to lift off the Machine. Lower the Cam (E) and knit the leg, narrowing as you come to the ankle by raising the Cam. After the hose is completed; cut off all above the ribbed top and through the ordinary yarn close to the SELVEDGE and pull out the little short remaining pieces, leaving the top clean and smooth.

25. A QUICKER METHOD OF PRODUCING HOSIERY WITH SELVEDGE RIBBED TOPS.

Knit a series of selvedge ribbed tops by (Par. 23) each joined together with the ordinary or different colored yarn through which you cut apart the tops as they are needed placing them on the Machine as follows:—With the Ribber off the Machine and all the needles in the Cylinder place one of the above ribbed sections down inside the Cylinder and place each loop or stitch over its corresponding needle. First see that the loops are all open and free from bits of yarn by raveling out two or three rounds and start with a loop where you stopped raveling back putting it over the first needle opposite the Carrier, so you can thread up through the guide holes in the Carrier the yarn you have raveled back. Study the formation of the loops in the ribbed section as shown in Fig. (8). Notice that half the loops were made by the Cylinder and half by the Ribber needles. Place with the fingers, first, all the outside or Cylinder loops over every other needle clear around as far as possible. With the Work Hook lift all the inside or Ribber loops on the alternate remaining needles.

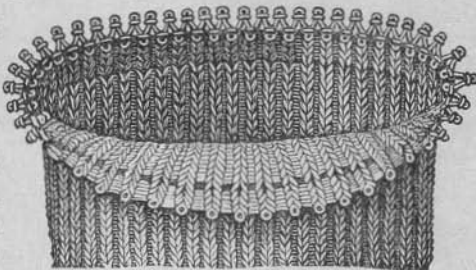

Figure 8.

After tying the yarn from the Carrier back up through the Guide to the yarn on Bobbin, gently hold down on the work and with the Cam very low, knit forward a little, bringing the remaining needles up for the rest of the loops. Readjust the Cam and you are ready to knit the leg.

26. TO READJUST THE RIBBER. Every Ribber is adjusted on the Machine at the factory and should not be re-adjusted unless necessary. If the Ribber needles drop the stitches; loosen the screw at (S) Fig (6). and force the Ribber Plate (Q) slightly to the right or left as necessary to cause the needles to properly take the yarn as it comes from the Carrier, to make the stitch. The latch of the Ribber and adjoining Cylinder needle should both close up on the yarn at the same time. The fan shaped guard on the Carrier bent and adjusted so that neither the Ribber nor Cylinder needle latches can possibly close until the yarn is taken up by them.

When the knitting clogs on the Ribber Needles you are knitting with the tension too tight or the knitting is not being held down sufficient or the Ribber is not high enough to permit the knitting to easily pass down between the Ribber and Cylinder. The Ribber can be raised, which always should be done anyway when knitting extremely heavy work.

The Pin on the under side of the Ribber Disk (R) can be bent to the right or left so that the grooves in the Ribber will come exactly opposite every other groove in the Cylinder. The Ribber should wave or wobble a little when in use to assist the knitting to pass down between. When any screws are loosened be sure to re-tighten them again, and keep the needles well oiled. Always hold down firmly on the knitting and directly underneath the Cylinder.

27. TO KNIT AN EXTREMELY LARGE RIBBED TOP FOR HOSIERY. This can be done as follows, but do not attempt it until you have successfully mastered the foregoing ribbed work; Set up the Machine with all the needles in Cylinder, place the Ribber on the Machine correctly, with the needles all in the Dial; start knitting the usual way, taking out of the Cylinder the one or two needles which you will find are directly in front of and hinder the operation of one or two of the Ribber needles. After knitting the required length, take off the Ribbing Attachment by lifting the Ribber needle stitch onto an adjoining Cylinder needle.

28. TO CHANGE RIBBER DIALS. If you have two Cylinders No. 72 and No. 60, and only one Ribbing Attachment, you can change just the Dial for the other Cylinder and use it with your same Ribber Plate. The Dial is taken off and changed by the screw and washer on the under side, and be sure that the new Dial runs easily on the Plate before using.



SECTION III.

GENERAL HINTS AND OBSERVATIONS TO FOLLOW.

29. TO KNIT DIFFERENT SIZES. There are three things that change the size of a stocking; First, the number of needles in a cylinder. Second; the length of the stitch. Third; the size and grade of yarn used.

The coarser the yarn the larger will be the web with any given number of needles, and of course, the finer the yarn the smaller the web. The coarse Cylinder will make a small stocking with fine yarn knit with a short or tight stitch. The fine Cylinder will not knit coarse yarn, and you always want to be careful not to try using yarn that is too coarse for your Cylinder, as you will surely damage your needles, experience will teach you how to grade your yarn in relation to the Cylinders. SEAMED knitting is always smaller than where a full set of needles are used. WIDENING and NARROWING is done by the adjustment of the Cam (E). To knit a small web, every other needle must be taken out of the Cylinder and the work knit tighter.

30. MENDING BROKEN OR SLIPPED STITCHES.

This is done with one of the Machine needles, while the knitting is on the Machine or off. The needle is used as a crochet needle by hooking it in the dropped stitch and pushing it far enough through to bring the stitch below the latch; then draw it back, catching the next cross-thread above, in the hook of the needle you are using; pull your needle out of the loop now, which will cause the new stitch to be formed just like the needle in the Cylinder makes the stitch. Proceed in this way until all the dropped stitches are picked up again, which were raveled down, and slip the last stitch made, over the Cylinder needle. If the mending is done out of the Machine, you tie the broken stitch with a short piece of yarn and the ends drawn inside the web with a loose Cylinder needle and tied again. You should always be careful to pick up broken or slipped stitches, as soon as made.

31. REVERSING THE MACHINE. When reversing the Machine with the work on, always lift at least 20 needles out of action, and turn the Machine until the Cam is directly under the raised needles and both latches clear, then reverse but of course, if you want to continue to knit, you must push these needles, raised, down in action again. Always see that the latch on the side in the direction you are turning, gets under and lifts up the first needle, or you may jam the Cylinder groove. This is IMPORTANT.

To reverse with an empty Machine, there are only two points to observe: Get the point of the latch, which is ahead, in the direction you wish to turn, under the needles by lifting the first two or three slightly, and lift up or lower the two or three needles ahead of the heel of the other latch, that it will not strike them. Do this operation slow and watch what you are doing and you will not have trouble.

32. TO KNIT FLAT WEB. By this is meant knitted work which is flat instead of tubular when it comes from the Machine. It can be most conveniently done when there are at least ONE THIRD of the needles removed from the Cylinder, and knitting backward and forward with the yarn over the TAKE-UP SPRING (N) just as in making the heels and toes. If desired, it can be done with all the needles in the Cylinder, and makes a larger web, as follows.

(a) WITH ALL NEEDLES IN USE. Set up the Machine as instructed, but do not knit a full round—stop with the Carrier nearly in front of the Machine,—lift up out of action the first 24 needles ahead of the Carrier, (after you have threaded up on them), and

turn the Machine so that the Cam rests directly underneath them, —now reverse the Machine as instructed in Par. (31), until the Carrier approaches these 24 needles (which we will call BATCH A) at the back, —push this BATCH-A down in action and lift the first 24 needles up out of action to the left of these (which we will call BATCH-B) and continue reversing the Machine until the Cam rests directly under this BATCH-B, —now turn the Machine forward again, push down BATCH-B and lift up BATCH-A in order as before and continue any number of times to make the required length of the web, which, when taken off the Machine, will be in one piece of flat web. A big variety of useful and practical articles can be easily made by stitching together with darning or crochet needle, a number of these flat webs of knitting. They can be knit in different colors as desired.

(b) TO KNIT TAPERED WEB, (SINGLE). Knit the web as instructed and as desired by either of the above methods, tapering-off by putting one needle out of action on each course knitted each time. Take the loop or stitch off of the first needle at the selvedged edge as you start reversing or turning forward and place it over the next adjoining needle then raise this empty needle out of action. After you have reversed the Machine, do the same with the loop on the first needle on the other selvedged edge and repeat. (DOUBLE TAPER). Take the loop off of both the first and last needles, one on each side, and place them over the next adjoining needles on the selvedged edges, pulling up out of action the empty needles as before. This will narrow the knitting two stitches each course.

33. TO KNIT A HEM OR DOUBLE TOP. Use cotton yarn or some cheap colored yarn to set up the machine, and knit about ten rounds, then tie on the yarn you wish to use in the article knitted and knit a section just twice as long as you want the hemmed top to be (say about twenty rounds). Take off your Set-up and pull this work up inside the Cylinder and place the first round of stitches or loops, made by the regular yarn, over the needles (so that there will be two stitches on each needle) being careful not to twist the work; after you take the work off the Machine you can cut and ravel out the cotton yarn.

On BOYS STOCKINGS, this hemmed or double top process can be nicely done, having the hem running below the knee, or by just knitting a little at the top and then using the Ribber to finish the leg.

In knitting LADIES or all long HOSIERY, the hem top should be made instead of the ribbed. As no Ribber is made for the No. 100 Cylinder, all knitting on this Cylinder should be made with hemmed tops.

BICYCLE and GOLF stockings should have deeply hemmed top and done in different colors; the hose knit rather long and the hem turned down over.

MITTENS with hemmed wrists are very satisfactory.

FOOTBALL and BASEBALL stockings are best knit with a small hemmed top and the leg knit in different colors as desired, and the Ribber used for the leg with all needles in both the Ribber and Cylinder, and the heel and toe re-enforced.

34. TO KNIT MITTENS. (Large Size)—Make a $4\frac{1}{2}$ inch cuff just like the top of a Gents Sock, either ribbed or hemmed, and to this knit two inches of plain before you start the thumb then for the thumb knit only on 24 needles at front of Machine, lifting all other needles out of action. Knit on these 24 needles a Plain Web of 45 courses, break the yarn and run the stitches off, leaving five inches of loose yarn attached for closing up the thumb after completion. With your Pick-up place on these 24 empty needles 12 stitches from each selvaged edge of flat thumb web; beginning close down to the hand where you started knitting web. Hold the work down well and with the thumb web down inside of Cylinder proceed to knit, with all cylinder needles in action, about 45 rounds for the hand. Close off just as you do the toe of the hosiery, and with a darning needle close up the thumb and this open end of the hand with the mitten turned wrong side out and your mitten is completed. (See Fig. 8).



Figure 8.

CHILDREN'S MITTENS. (Small size)—These are made with plain flat web, knitting the web wide enough so that when folded it will be the required size of mitten. Start by knitting a section of three or four inches of seamed wrist, by taking every second or third needle out and knitting tight. Put the needles in and lift on a loop from below the next adjoining needle, that there will be no holes. Now knit backward and forward a sufficient number of courses, about



Figure 9.

100 to make the required length. Lay a pattern of the required size on this section turned wrong side out and sew through with a good strong stitch, around the thumb and across the fingers, as shown in Fig. (9). Cut out the part marked (a), stitch up the selvedge edge along the thumb and wrist, turn right side out and you have it. FOR A LITTLE LARGER SIZE, knit the whole section, wrist and hand, tubular on all needles instead of flat web,

and with the wrist hem or ribbed if desired; sew and trim. Different colors can be woven in or a fancy stitch can be made for the wrist.

35. By knitting flat web with floss or heavy Saxony yarn, and sewing these sections together, you can make many different articles.

TABLE or LAMP MAT.—Knit six flat webs starting with all needles and tapering each section down with the **SINGLE** taper to a point. Sew these sections together by the selvedged edges with the points at a center. All sections can be knit different colors and pretty arrangements can be made, and with a fancy border as desired.

HOODS.—Knit a flat loose stitch web on a sufficient number of needles to make the web wide enough to cover from the forehead to the upper back part of head, (on the 72 Cylinder about 60 needles,) and long enough to cover from below the right ear up over the head and down below the left ear, starting and finishing this strip with small hem, for the tie ribbon to go through. The **BACK PIECE** is knit a flat web on about the same number of needles, starting with a small hem and tapering **OFF DOUBLE** after a sufficient length is knit full width to permit the joining of this piece to the first part at the back properly, and will contain about half the courses that the **TOP PIECE** contained. Join the **BACK** and **TOP** pieces together on the wrong side with a good stout stitch at their selvedge edges so that the hems on both pieces connect at the bottom for the **TIE RIBBON**. A ruffled or fancy stitched section can be sewed onto the **TOP** piece at the front along the selvedge.

CHILDS SOCK OR STOCKING with seam.—This is also done by knitting flat web, and can be made any size, even for dolls. Knit back and forward on a sufficient number of needles, so that when the web is doubled it will be the required width of the hose. Do this knitting on the front part of Machine, starting with a loose stitch and tightening at the courses which will be the ankle. Knit a small heel by the usual method, only, in this case, use just half the needles in action, which will be those in use through the middle of the web; pulling up out of action a sufficient number to the right and left of these to make it correct. Knit a complete heel on these needles but narrow down to 6 needles instead of 12 then push all the needles you started with, down in action again, to knit the foot. After the foot is knit long enough the toe is knit in two **DOUBLE** tapered sections as follows:—Pull up out of action, just half the needles in use, (the half farthest away from the Carrier.) Knit on this first half a **DOUBLE** taper web which will run the work off these needles, then break your yarn and tie around the first needle in the next half, lifted up; now

put them in action and **DOUBLE** taper off of these, and the hose is completed except the sewing up on the wrong side, the selvedged edges clear along to the top. Fancy stitches can be knit in the leg, and in colors, or the knitting process can be reversed, making the seam at the back instead of front.

36. RAVELED TUBING for SCARFS. Knit loosely, a tube or circular section, with all needles in the Cylinder, or with all needles in the Cylinder and with the Ribber in use too. Knit this any length desired and run it off the Machine. Ravel down the stitches made by the Ribber needles, or if Ribber was not used ravel every second or third stitch, and make fringes on the ends.

This same process can be done to long sections, cut down one side to form wide webs, then sew together to form **JERSEYS**, **SWEATER VESTS** and many other articles of clothing.

LEGGINS are knit in circular sections like scarfs, only you ravel down just enough series of stitches to make the required size, and **DOUBLE TAPER** off on half the needles, at the front of Cylinder for a covering of the instep. Make a small hem at the top, or **BIND** at both the top and bottom with a separate piece of narrow web knit tightly. Straps of string material can be fastened at the bottom and under the shoe.

WRISTLETS OR PULSE WARMERS are made with 4 or 5 inch ribbed sections, with the regular selvedge made on one end, and to finish the other end draw up the loops with a machine or a darning needle.

FANCY STITCHES

All fancy stitches should be knit with a loose tension or stitch and they make very attractive patterns. We cannot show by illustration a very good representation of the patterns, therefore we request you to learn to knit each pattern in order to see the actual effect produced. They are well worth the trouble of working out and can be used for a variety of purposes, e. g., borders for Scarfs, Table Mats, Hoods or Bonnets, Caps and a number of things. Always start and finish with a good selvedge.

TIDY PATTERN. Set up flat web of required width; knit once across, change the stitch from the second needle to the third, the fourth to the fifth, and so on across; moving to the left knit across forming loops on the empty needles, knit back again forming stitches with these loops; put the stitch from the second needle over the first, that of the fourth over the third, moving the stitches to the right, knit across and back as before, change the stitches to the left and continue.

CHEVRON STITCH. Set up flat web on every needle for the desired width; knit once across, put the stitch from the alternate needle upon the next needle to the right, knit once across and change the loops one needle to the right; work thus twelve times across, and change the loops to the left twelve times, knitting across each time as before. For wider work, knit more than twelve times across, before changing, for narrower, less. This makes a suitable trimming for children's garments, etc.

LATTICE PATTERN. Commence as before by taking the stitch from every other needle and putting them over the next to the left, knit once across forming loops, move the loops to the next needle to the right, knit across, and carry the loops to the left; knit across and carry the loops to the right, and so on to the length desired.

BAR AND DIAMOND PATTERN. Set up, knit across, change every alternate stitch to the left, knit across, forming loops, and back forming stitches on the empty needles; change the stitches formed with loops to the right. Knit twice across as before and change to the left and so continue. When knitting fancy stitches, the tension should be loose.

Chevron stitch or Bar and Diamond stitch are suitable for scarfs.

TO KNIT CORD. Take out of the machine all but four needles. Set up and attach the heel hook and the light weight. Knit across: pull the needles up as high as they will go; place the thread inside the needles and run back; put the needles down so they will knit and knit across as before, then run back again and so continue knitting one way and running back with the needles up and the yarn inside the needles.

OBSERVATIONS.

A careful record should always be kept of the number of rows in the various sections of the articles knitted, and of the tension at which they are knitted, as the latter affects very considerably the length of the knitting and the amount of yarn consumed. It is possible to record the tension somewhat, by the amount of the Cam Stud projecting up above the Cam Nut (G)

A good **GENTLEMEN'S HALF HOSE** for the **TRADE** is knit as follows: Commence by forming a good selvedge at the top, and knit a 5 inch Ribbed Top for the welt; then place all needles in Cylinder where left out for the rib, transfer the rib stitches onto these, knit an 8 inch leg, making 13 inches with the ribbed top

and stop the Yarn Carrier at front of Machine. Knit re-enforced heel, foot (70 to 80 rows according to length required), and toe, and finish off. Size of foot 10 to 11 inches; medium 10 1-2 inches. If you have the RIBBING ATTACHMENT, be sure to use it for the top or welt.

RE-FOOTING worn out hosiery, is easily done on the Machine by cutting off the old foot at the ankle, placing this good section on the needles and knitting a new foot to it, as required. If the Cylinder carries more or less needles than there are stitches in the piece to be knitted to, place two loops of the piece on a needle that there will not be any ravel stitches. Read paragraph 25, SECTION II.

EXTRA CYLINDERS. There are NINE different cylinders which fit the same Machine, each doing a different grade or variety of knitting.

The 72 NEEDLE CYLINDER knits common yarns and will also knit coarse cotton well. If a single thread is too fine, knit two threads off of two bobbins at the same time.

The 54 CYLINDER knits children's sizes from fine yarn, and medium sizes from coarse yarns. It uses all common factory yarns, and has the same sized or gauge needle, (No. 12), as the 72 cylinder.

The 60 CYLINDER with No. 10 gauge needles, knits large sizes from heavy and homespun yarns or common yarn doubled.

The 52 CYLINDER knits the same grades of yarn as the No. 60 and uses the same needles but does all the small sized work.

The 88 CYLINDER uses No. 12 gauge or No. 18 gauge needles (with No. 44 DIAL) for finer yarn than the 72 cylinder.

The 100 CYLINDER uses No. 18 gauge needles only (with No. 50 DIAL) for knitting saxony, fine wool and coarse cotton for Gent's and Ladies' wear.

The 112 CYLINDER uses No. 18 gauge or No. 24 gauge needles, (with No. 56 DIAL) for all fine grades of knitting Heathermix, Saxony, etc.

The 120 CYLINDER uses No. 24 gauge needles only (with No. 60 DIAL) for knitting fine cotton, wool and lisle and all fine light knitting.

The 140 CYLINDER uses No. 24 gauge needles only (with No. 70 DIAL) for knitting very fine work, lisle, silk, cotton, etc.

PRICE LIST OF PARTS.

When Ordering Parts of Machine, Observe the letters and be sure to mention, as near as Possible, how long you have had your Machine and the Model it is.

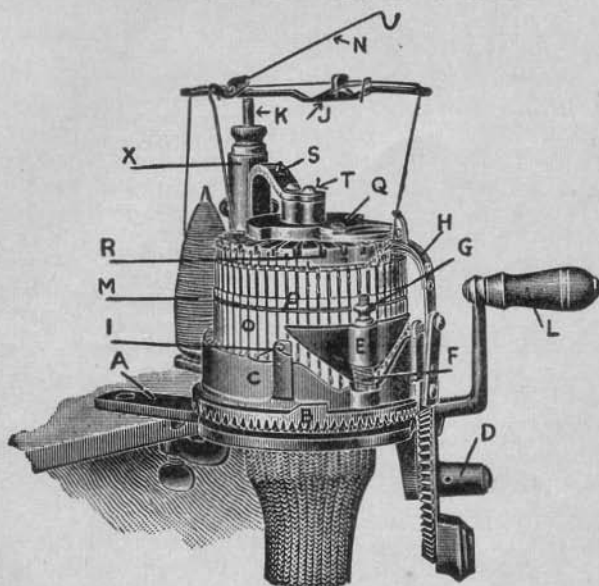

MODEL 1914—1914-B
 AND
 ALL "STANDARD"
 Gearhart Knitters

PRICE LIST OF PARTS NEEDED FOR REPAIRS:—STANDARD MODEL Always refer to the letter and name of part wanted.

A Frame.....	\$5.00	B Crown Wheel	\$2.00
C Cam Ring	2.50	D Gear Wheel with Crank	2.00
E Cam50	F Spring under Cam10
G Cam Nut15	H Thread Carrier50
I Latch (right or left).....	.10	J Yarn Guide and Spring	1.00
K Yarn Guide Standard.....	.15	L Handle15
M Bobbin10	N Take-up Spring.....	.15
O Cylinder No. 52, 54, 60, 72, 88		P Wire Band25
100, 112 120, 140, @ .06 per groove		R Ribber Dial 30, 36, 44, 50, 56,	
Q Ribber Plate & Cam.....	2.25	60, and 70 @ .05 per groove.	
S Ribber Post.....	.75	T Screw and Washer10
X Weight for Take-up Spring.....	.20	Hold-down for Heel20
Heel hook.....	.10	Work hook or Pick-up.....	.10
Weight, large or small.....	.25	Set-up75
Thumb Screw15	Oil Can15
Needles, @ .06 each, per dozen.....	.72	Knitting Tabulator	1.00
Instruction Book.....	.50	Machine Oil, with can.....	.25
		Buckle Hold Down.....	.35

When ordering needles, please send sample and state for what Cylinder wanted. Always mention what screw and washer are wanted for.
Extra Large Bobbins will be sent for 30 cents each.

THESE PRICES INCLUDE POSTAGE TO ANY PART OF THE UNITED STATES
ALWAYS WRITE YOUR NAME and ADDRESS PLAINLY & MENTION THE NO.

All former prices and discounts cancelled.
Prices subject to change without notice.

GEARHART KNITTING MACHINE CO.,
CLEARFIELD, PA., U. S. A.

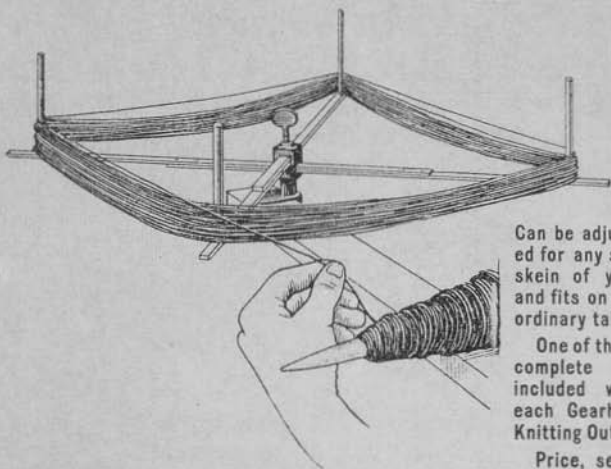

GEARHART'S Yarn Winder and Reel

BEST AND FASTEST
YARN WINDER MADE

Can be adjusted for any size skein of yarn and fits on any ordinary table.

One of these complete are included with each Gearhart Knitting Outfit.

Price, separately, - -



\$3.00 Postpaid

Tabulator Attachment

Easy to apply to any Gearhart Machine, and is indispensable for accurately tabulating a given number of rounds of knitting to give the required lengths.

Price \$1.00, by mail.

Gearhart Knitting Machine Co.,

Clearfield, Pa.

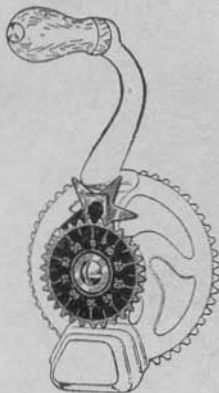

IMPORTANT

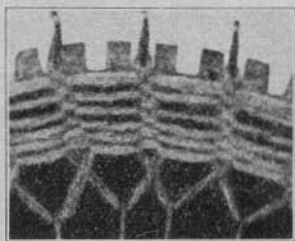

(Figure A)

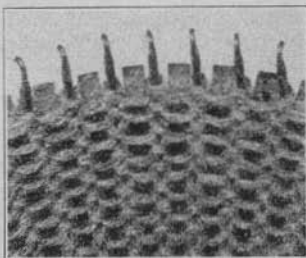

(Figure B)

(Figure A) is the correct stitch size made with every other needle out in preparation for placing on the Ribbing Attachment, with the Cam E. Indicator at about notch 3.

(Fig. B) is the correct stitch after transferring the Ribber stitches to the cylinder needles and lowering the Cam E to indicate about notch 1. Turning the thumb nut clockwise. The socks should be knitted very loose.

Knitting Yarns

To obtain the best results in Machine Knitting, the yarn should be especially selected, and we recommend our customers to purchase their supplies from us, or from the firm where you bought the Machine. By placing large contracts with the spinners, we are able to supply the best yarns for use on the Machine, at specially low prices. Always use the quality of yarn you are instructed to use, in knitting for us and the trade.

When Returning Machines or Parts for Repairs

Place your name and address CAREFULLY on the Parcel, as well as inside, so we may know whom it is from, and send it CHARGES PREPAID; also write to us at the same time detailing the repairs needed, with instructions for re-shipping.

Always give your working number.

