



SINGER*

1110 / 2110 / 1310 / 2310 / 600

Contents

Your machine

	Page		Page
● Single Bed machine	3	● 1/4 pitch lever	9
● Conversion kit	3	● Needles	10
● Double bed machine	4	● Needle positions	11
● Accessories	5-7	● Carriages	11-12
Tension unit bracket	8	● Coupling catch	12
Row counter	14	● Selection keys	12
● Needle beds	8	● Stitch size dial	12
Bed position levers	10	Needle return buttons	13
● Space selector	8	Needle selection buttons	13
Intermediary lever	9	Locking levers	13
Racking lever	9		

Stage one

	Page		Page
● Hints before and during knitting	14	● Straight vertical opening	21
● Threading	15	Chain casting-off	22
● Casting-on in 1/1 Simple rib	16	During knitting	22
● Transferring from rib to stocking stitch	17	● Needle bed opening	23
● Stocking stitch	17	Undoing one or several rows	23
● Chain casting-on	18	Picking up dropped stitches	23
● Mock rib	18	● To remove or re-hang half-knitted work	24
● Increasing	19	● Assembling	24
● Decreasing	19	Sewing	24
● Needles in holding position	20	Grafting	24
● Part-row knitting	20	Finishing	24
● Necklines	21-22	● Garments made to measure	25
Armhole an shoulder shaping	21	● Test sample, size chart	26-27
		● Conversion table	28-29

Stage two

	Page		Page
● Casting-on in stocking stitch	30-32	● Close rib	47
● Increasing in stocking stitch	32	● Circular stocking stitch	48
● Decreasing in stocking stitch	33-34	● Semi-circular stocking stitch	49
● Casting-off	35	● Thick yarn	50
● Casting-on in 1/1 Simple rib	36-37	● Buttonholes	51
● Casting-on in 1/1 Double sided Fisherman rib	38	● Hems	52
● Casting-on in 1/1 Single sided Fisherman rib	39	● Hem-fold	53
● Casting-on in 2/2 Simple rib	40	● Neckband	53
● Casting-on in 2/2 Double sided Fisherman rib	41	● Pockets	54
● Casting-on in 2/2 Industrial rib	42	● Socks	55-56
● Casting-on in 2/1 Simple rib	43	● Fair Isle	57
● Mock rib	44	● Norwegian Jacquard	58
● Increasing and decreasing in 1/1 Simple rib	45	● Jacquard	59
● Decreasing in Single and Double sided Fisherman rib	46	● Weaving effect	60
● Decreasing in Single and Double sided Fisherman rib	46	● Racking patterns	61
		● Fancy patterns	62-66
		● Fancy rib	66-68
		● Changing a needle	68
		● Maintenance and care	69
		● What to do if	69-70

Your machine

● Single bed machine	Page 3	● Carriages	Pages 11-12
● Conversion kit	Page 3	● Yarn guide	Page 11
● Double bed machine	Page 4	● Coupling catch	Page 12
● Accessories	Pages 5-7	● Locking levers	Page 13
● Tension unit bracket	Page 8	● Selection keys	Page 12
● Row counter	Page 14	● Stitch size dial	Page 12
● Needle beds	Page 8	● Needle return buttons	Page 13
● Bed position levers	Page 10	● Needle selection buttons	Page 13
● Space selector	Page 8	● Needles	Page 10
● Intermediary lever	Page 9	● Needle positions	Page 11
● Racking lever	Page 9	● Stitch formation	Page 10
● 1/4 pitch lever	Page 9		

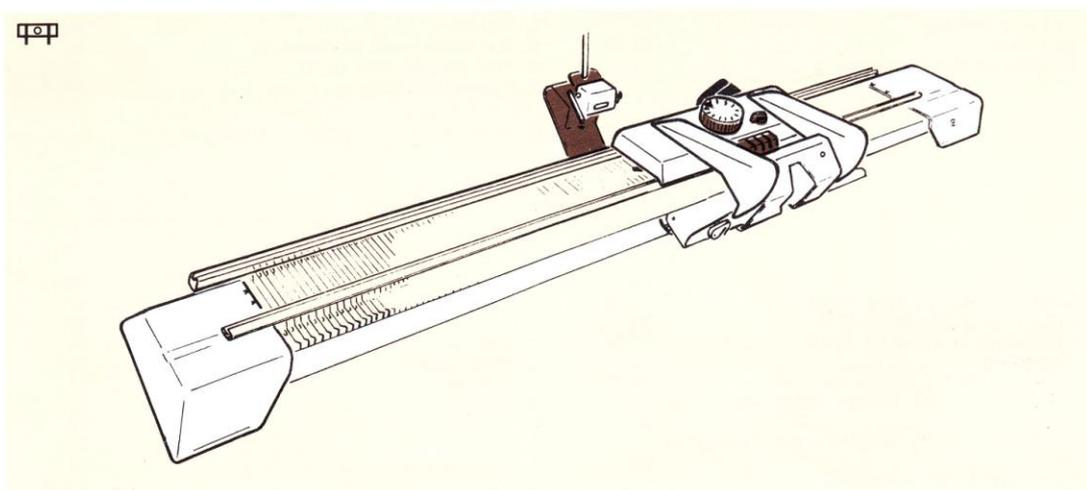
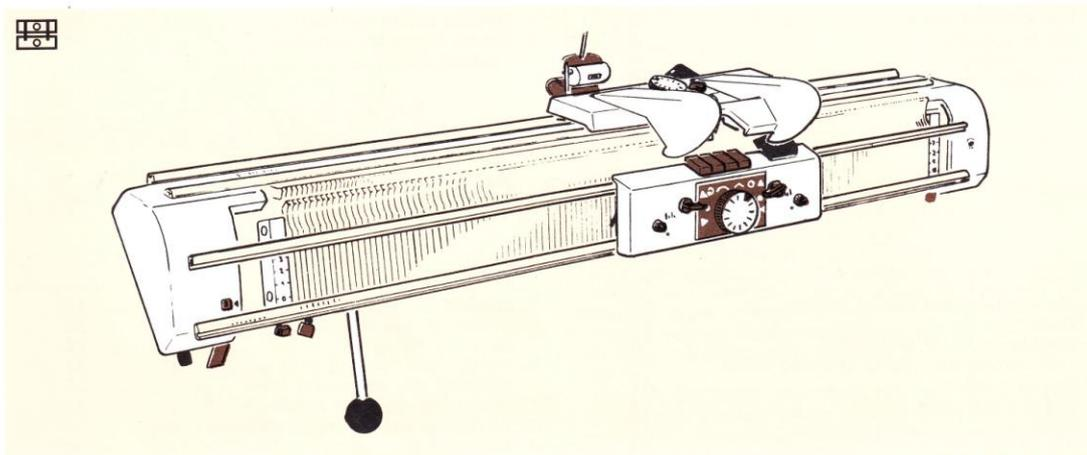

Important advice

WE RESERVE ALL RIGHTS OF MODIFICATION ON THE CONCEPTION AND PROPERTIES OF OUR MACHINES. THE INFORMATION GIVEN IN OUR DOCUMENTS ARE INDICATIVE AND WITHOUT OBLIGATION.

2

— The explanations you will find in this instruction book will refer often to the PARTS OF THE MACHINE AND THE ACCESSORIES.

— They will help you to understand your machine if you acquaint yourself with the different parts and their terminology so that you may quickly become an expert knitter.

— We invite you to refer often to these first pages.

The single bed machine

Principal parts

1. Tension unit
2. Row counter
3. Carriage
4. Needles
5. Needle bed
6. Knitting retainer
7. Needle return buttons
8. Jacquard key
9. Stitch size dial
10. Selector keys
11. Locking levers
12. Yarn guide

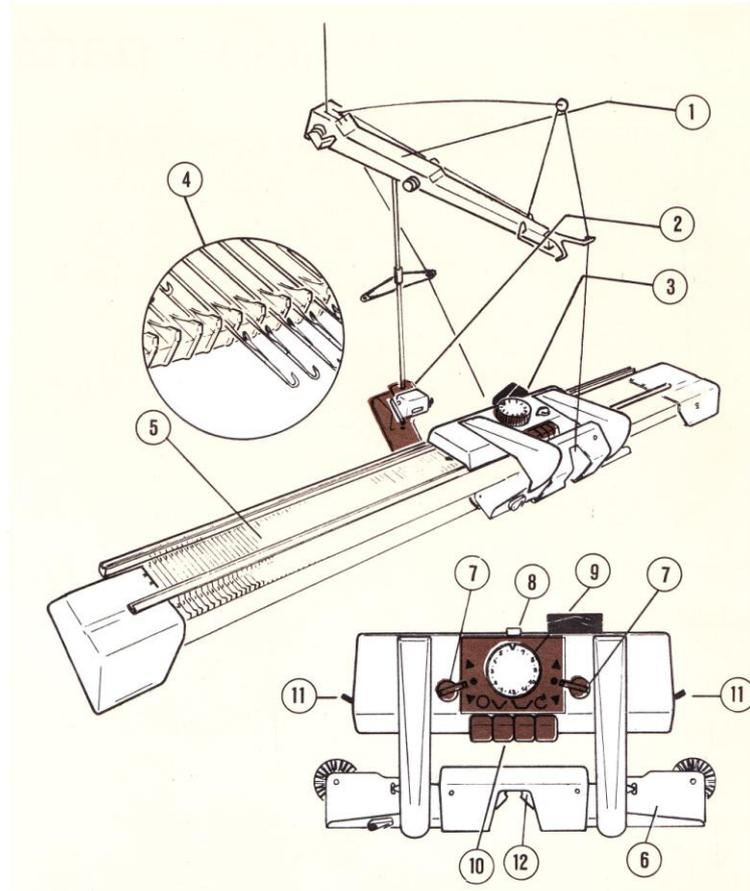

The conversion kit

- If you enjoy the possession of a **SINGLE BED** machine, you could whenever you like, **CONVERT IT** into a real **DOUBLE BED** machine by means of the conversion kit.
- The conversion bed is supplied with the front carriage and the appropriated end covers.

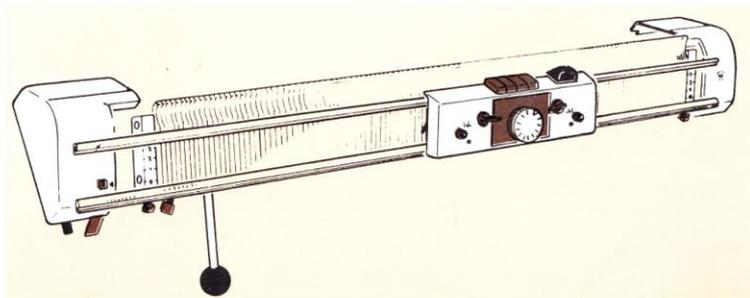

The double bed machine

Principal parts

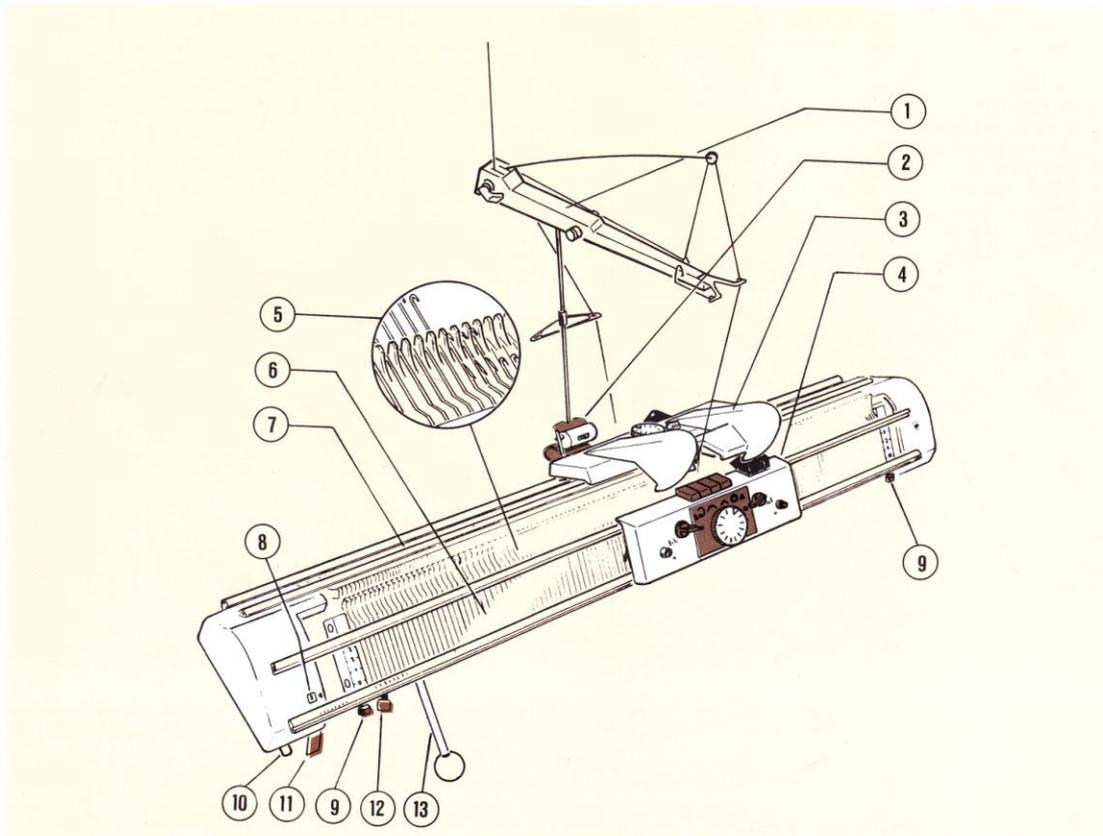

1. Tension unit
2. Row counter
3. Back carriage
4. Front carriage
5. Needles
6. Front needle bed
7. Back needle bed
8. Space selector indicator
9. Bed position lever
10. 1/4 pitch lever
11. Space selector
12. Intermediary lever
13. Racking lever
14. Needle return buttons
15. Jacquard key
16. Stitch size dial
17. Selection keys
18. Locking levers
19. Yarn guide
20. Needle selection buttons (front carriage)
21. Coupling catch

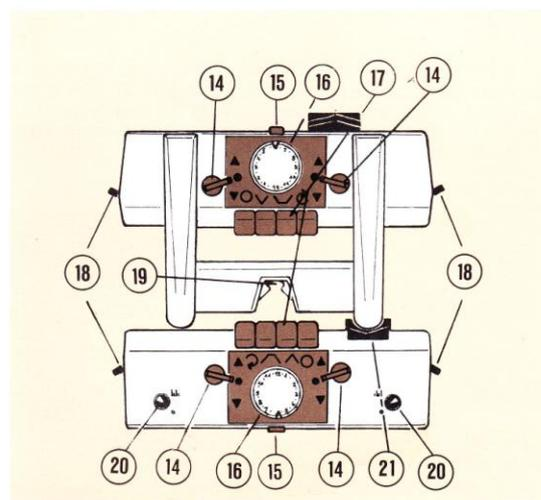

Hints to read the instruction book

This instruction-book is intended at same time to customers owing a DOUBLE BED machine and to those owing a SINGLE BED machine.

Read carefully the below indications which will permit you to distinguish the titles and chapters which concern you particularly.

If you own a D.B. machine

- Refer to the special sign placed next to above title. It represents two carriages and is to be find on the head of the text concerning you.
- Ignore the signs concerning the S.B. MACHINE (only 1 carriage).

If you own a S.B. machine

- Refer to the special sign placed next to the above title. It represents one carriage and is to be find on the head of the text concerning you.
- Ignore the signs concerning the D.B. machine (2 carriages).
- If it handles about a chapter destined to the D.B. machine and your S.B. machine the same time, ignore the parts of the text printed in thin italic characters.
- Refer attentively to the special remarks printed on a blue background to be found on the bottom of certain texts.

Available accessories

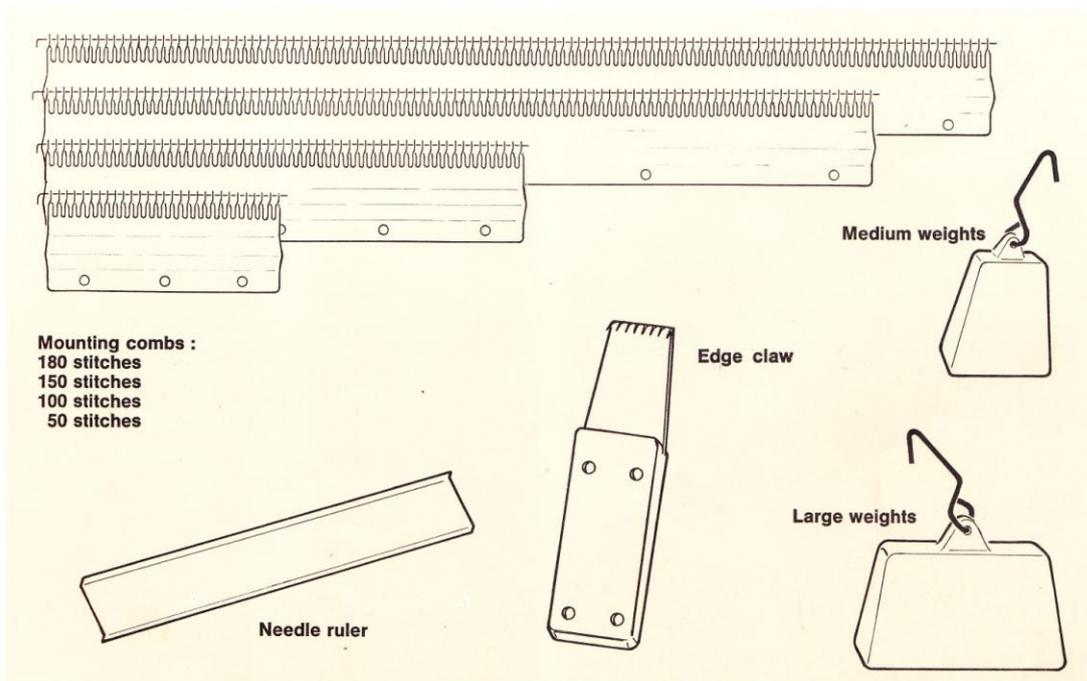

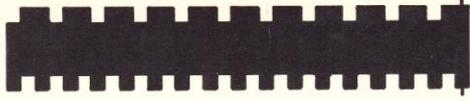

Needle selector

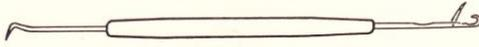

Latch Needle tool with hook

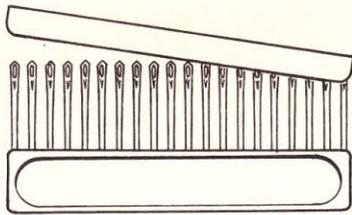

20 Eyelet Transfer Tool

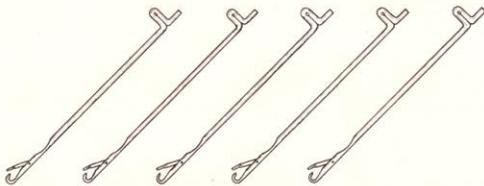

Spare needles

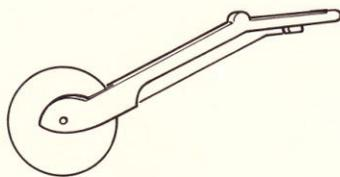

Pushing-down wheels

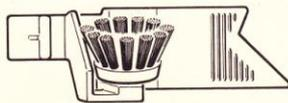

Weaving effect brushes

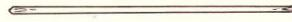

Double Ended Eyelet Needle

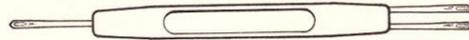

Single and Double Eyelet Transfer Tool

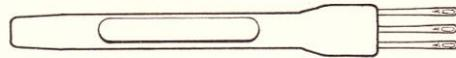

Three Eyelet Transfer Tool

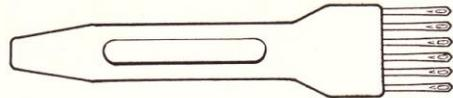

Six Eyelet Transfer Tool

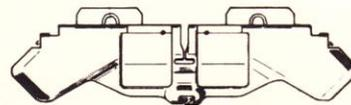

Second yarn guide

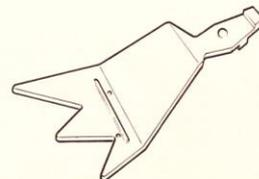

Jacquard claw

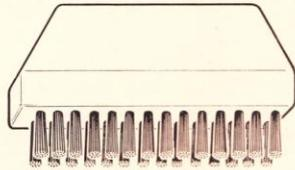

Cleaning brush

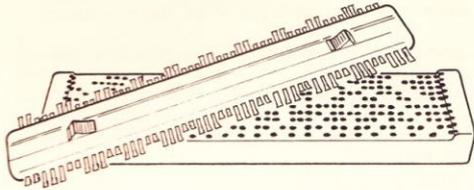

Universal needle selector

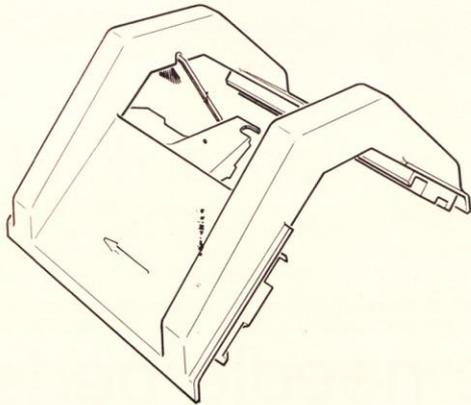

Transfer Carriage

Makes the automatic transfer of ribs to stocking stitch.

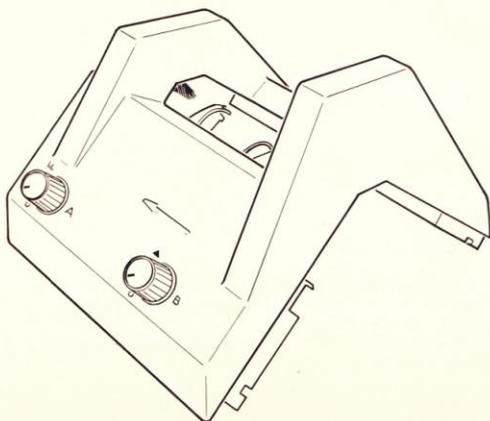

Double Garter Stitch Carriage

Allows to get quickly the double garter stitch and its derivatives as well as fancy lace patterns.



Oil dispenser

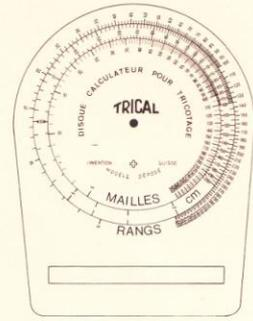

Trical Calculator disc

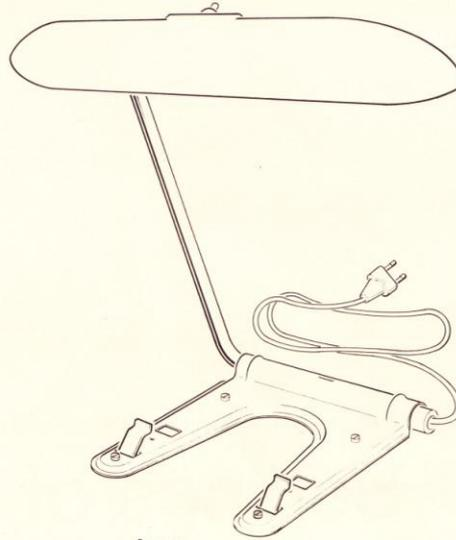

Lamp

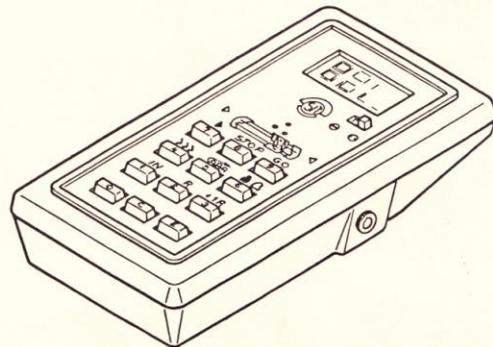

Knitting computer

Allows to create your own fashion and avoids tedious calculations. This accessory is delivered with a model book and explanations.

How to set up the machine

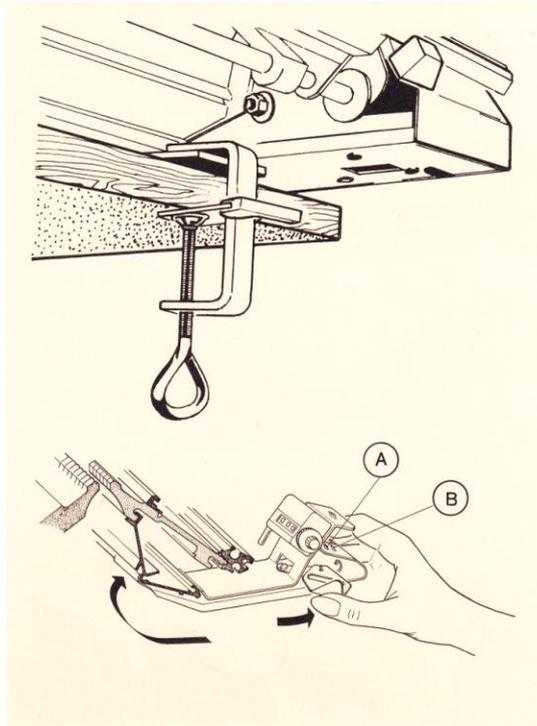

- Place the machine on the table, making sure the table protectors are in line with the edge of the table.
- Fix the machine with the clamps.

After having set up the machine:

- Slide the tension unit stand under the back needle bed in line with the 0 on the graduated scale
- Locate the forward edge of the stand into position as illustrated.
- Secure the stand by pushing the lever towards the left.
- Fit the tension rod in the hole (B) of the tension unit stand.

NOTE FOR S.B.: In this case, the tension rod has to be fitted in the hole (A).

Settings of the needle beds

Needle bed space

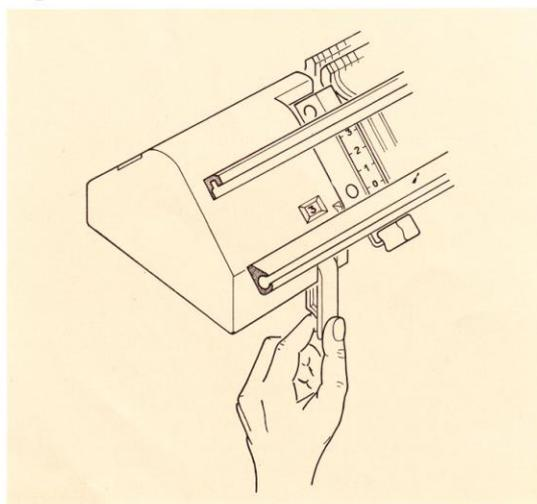

NOTE FOR S.B.: No needle bed position to observe.

SPACE SELECTOR

The needle bed space is adjustable by means of the space selector placed under the left end of the front needle bed. This space varies from 3 to 6 mm according to the thickness of the yarn.

TYPE OF YARN	NEEDLE BED SPACE
Fine	3
Medium	4 or 5
Thick	6

The racking lever

The racking lever is folded under the front needle bed.

- To pull it out, swing the lever downwards until it clicks into the locking bracket.

- To fold it away, pull (under the needle bed) on the locking bracket and push the racking lever upwards.

This bracket can be seen when the front needle bed is in lower position.

Each notch towards the right or the left corresponds to one racking.

Lateral adjustment

The front needle bed can be moved laterally with the racking lever to 8 positions or notches.

This adjustment allows :

- positioning of flow combs opposite or alternate
- to knit racking patterns
- to knit ribs and fancy patterns using every needle.

When the extremities of the needle beds are parallel, consequently flow combs opposite, the index faces $4\frac{1}{2}$ on the racking scale.

Pitch lever

This lever allows to move the flow combs $\frac{1}{4}$ of a pitch transferring stitches from one bed to the other.

The lever is found under the left end cover of the machine; it can be moved in two different positions, i.e.:

- Flow combs opposite or alternate: the lever is positioned towards the front, when not using the transfer position.
- Transfer position: the lever is positioned towards the back.

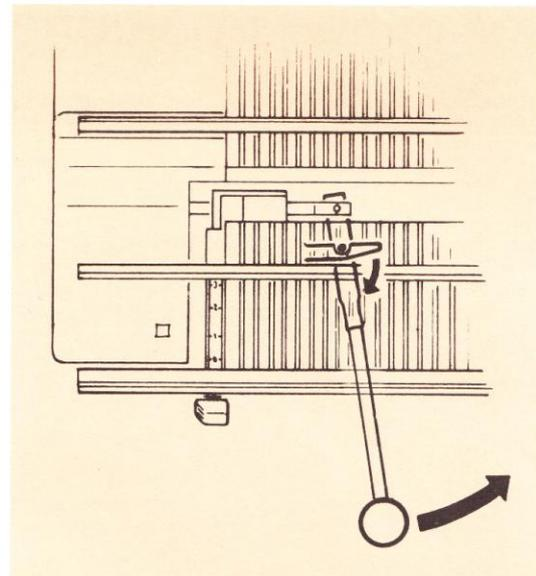

Intermediary lever

This lever determines the flow combs position according to the direction it is moved;

- Towards the left: flow combs opposite.
 - Towards the right: flow combs alternate (this position allows to use all needles on both needle beds).
- In both cases you must use the intermediary lever with the racking lever (1 notch) to obtain the required position.

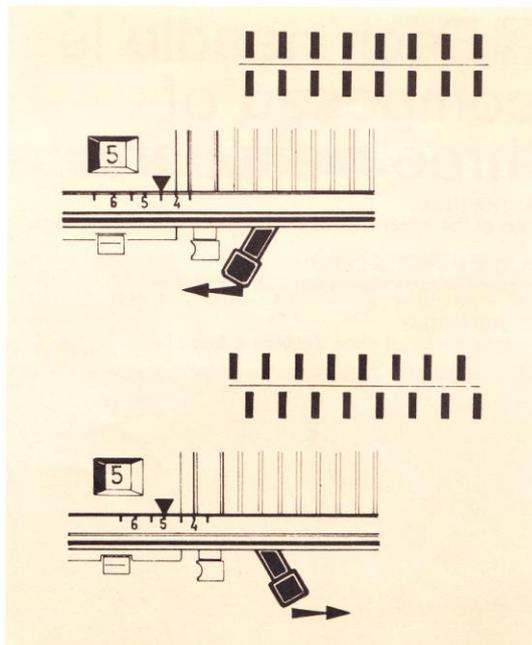
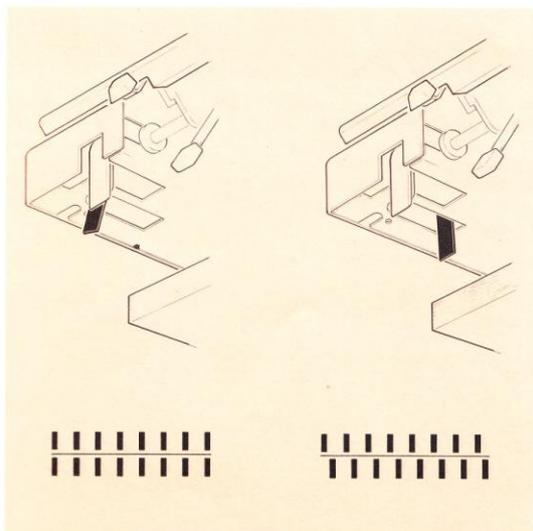

Knitting positions Open positions

NORMAL POSITION 1: Both needle beds are at the same level. This position is used for all patterns knitted with two carriages.

UPPER POSITION 2: The front needle bed is higher than the back needle bed. This position is only used for stocking stitch and its derivatives.

The flow combs **MUST BE OPPOSITE**.

Only the back carriage is used in this case, the front carriage can be removed.

INTERMEDIARY POSITION 3: It is used for checking the knitting and to facilitate the transferring of stitches from the back needle bed onto the front needle bed.

LOWER POSITION 4: It gives a much better visibility of the knitting and facilitates operations like casting-on and -off, checking or the counting of the rows.

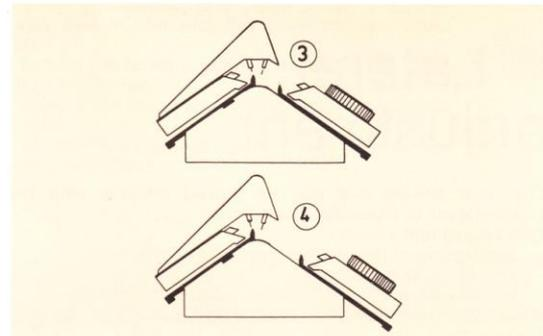
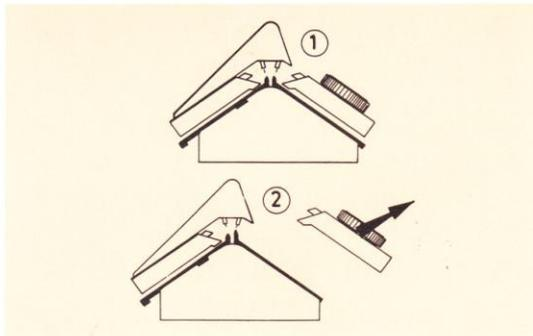

How to obtain the different positions of the front needle bed

● Push towards the centre, then release the **TWO BED POSITION LEVERS**, placed under No. 90 of the graduated scale.

The needle bed is thus unlocked and can be moved into the required position.

IMPORTANT NOTE: Separate the two carriages when changing the front needle bed position. This operation is explained on page 10.

The needles

Each needle is composed of three main parts :

A. THE HEEL:

part of the needle which is in contact with the carriage.

B. THE MOVABLE LATCH:

closes the hook during the stitch formation.

C. THE HOOK:

retains the stitch when the yarn is layed in.

Stitch formation

Knitting is a sequence of stitches formed by a yarn. With hand-knitting, the stitches are formed using two needles. With machine knitting, each stitch is formed by individual needles. When passing the carriage across, the needles move in sequence upwards and then downwards.

● When moving upwards, the needle makes the stitch slide behind the latch (A and B).

● The yarn is then presented by the yarn guide found between the carriages.

● When moving downwards, the stitch closes the latch and slips out of the needle (C). A new stitch has been formed (D).

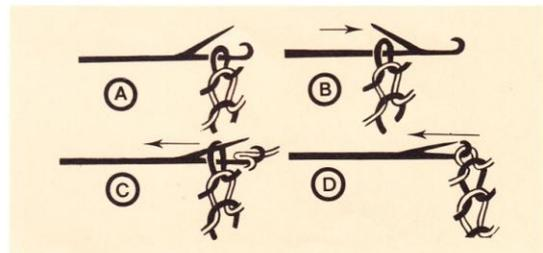
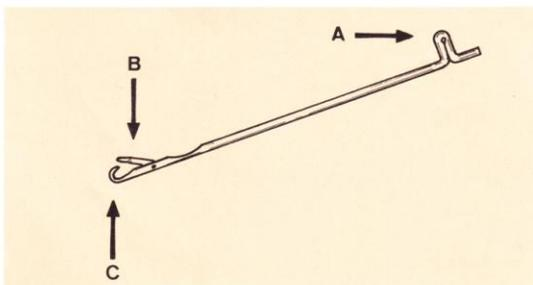

Needle positions

Each needle bed has 180 needles which can be placed into required positions.

- **NON-WORKING POSITION No. 0:**
It is the lowest position. The needle heel rests against the lower slide rail.
- **WORKING POSITION No. 1:**
This is the first knitting position. The needle hook is level with the flow combs.
- **WORKING POSITION No. 2:**
This is the second knitting position. The open needle latch is level with the flow combs. The stitches are behind the latches.
- **HOLDING POSITION No. 3:**
This is the highest position. The needle heel rests against the upper slide rail.

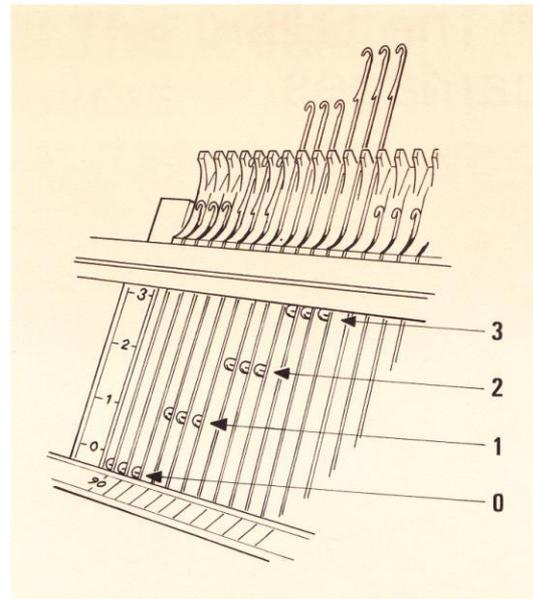

The carriages

The S.B. carriage

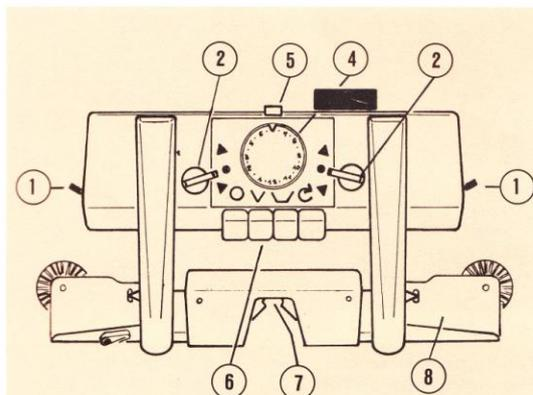

1. Locking levers
2. Needle return buttons
3. Needle return buttons
4. Stitch size dial
5. Jacquard key
6. Selection keys 
7. Yarn guide
8. Knitting retainer

The knitting retainer:

The two slots of the knitting retainer fit beneath the two handles of the carriage between the plastic cover and the metal part (the two wheels are exactly underneath the flow combs).

- **To fit it:**
Push the knitting retainer upwards and then move it to the left.
- **To remove it,**
press down the small lever on the left-hand side of the knitting retainer and reverse the above action.

Before fixing the knitting retainer and for any type of knitting except for weaving effect, remove both central wheels by pushing them towards the front.

The knitting retainer is fixed after having knitted 4-5 rows and eliminates in certain cases the use of weights. We recommend however to use weights in case the knitting rises.

The to-and-fro movement of the carriage determines the movement of the needles to obtain knitting.

The D.B. carriages

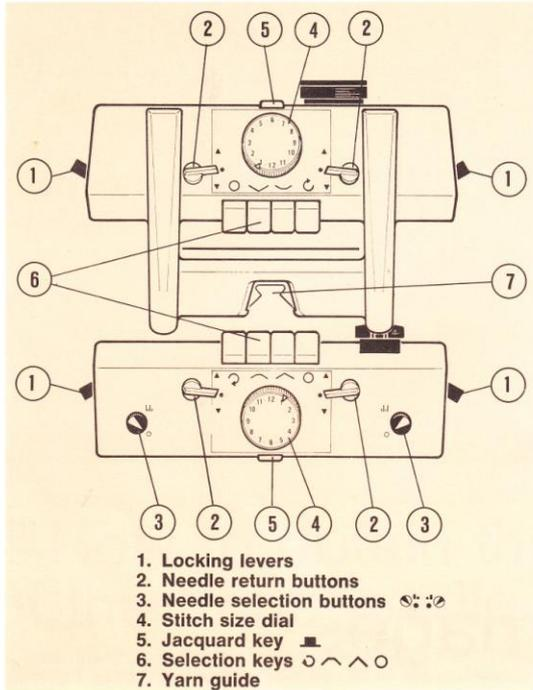

The D.B. machine is equipped with two carriages.

The front and back carriage can be separated and coupled automatically by a catch situated on the front carriage.

● To separate press the catch down.

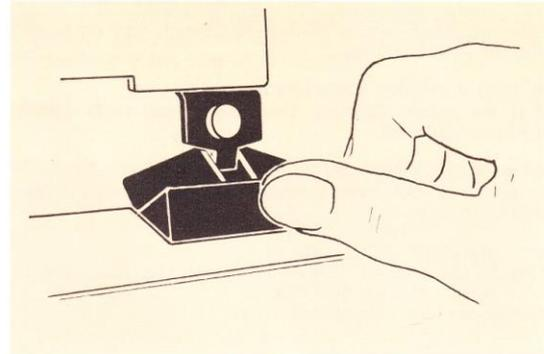

Knitting is obtained by a to-and-fro movement.

— either with the back carriage only to knit stocking stitch and its derivatives;

— or with the two carriages to knit circular, ribs, single and double sided Fisherman's rib, fancy patterns, and all stitches knitted on both needle beds at the same time.

The stitch size dial

This dial determines the downward movement of the needle, thus the length of the stitch and the softness of the fabric.

● Turn the dial to bring the arrow opposite to the required stitch size.

Selection keys

EACH CARRIAGE HAS FOUR KEYS FOR BASIC STITCHES:

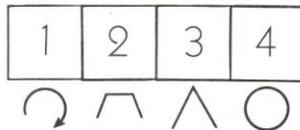

1. Key  : it is mainly reserved for CIRCULAR knitting.

The term «Circular» means that the carriages knit alternative, i.e.: the FRONT carriage knits from right to left and the BACK carriage knits from left to right. Circular knitting allows to make seamless garments, like skirts, socks, hats.

2. Key  : it forms LOOPS (the yarn is layed over instead of forming a stitch).

3. Key  : to knit all classic stitches derivated from STOCKING STITCH. The carriage knits in both directions.

4. Key  : It CANCELS the other keys. Only this key DOES NOT REMAIN DEPRESSED and comes back to its original position.

NOTE: the combination of the different keys on the back and on the front allows many knitting possibilities. In this case depress simultaneously the required keys.

12

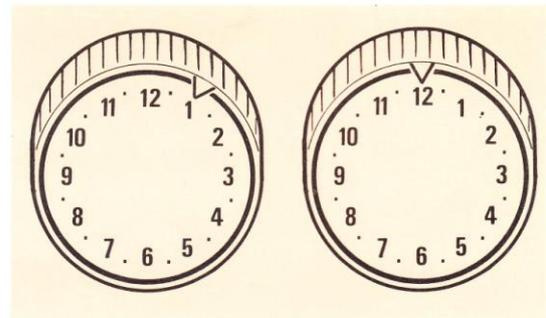

The higher the number the longer the stitch.
The smaller the number the shorter the stitch.

ADJUSTMENT OF STITCH SIZE (STOCKING STITCH) IN COMPARISON TO HAND KNITTING NEEDLES

HAND KNITTING NEEDLES	STITCH SIZE DIAL
2 mm Fine Yarn	3-4
2 1/2 mm 2 ply	4-7
3 mm 3/4 ply	7-9
3 1/2 mm Double Knitting	9-12
4 mm Thick yarn	

The needle return buttons

The carriages have in addition two buttons to automatically recall needles from holding position back into working position.

These buttons have three positions:

A. UPPER POSITION

It is used to knit two-colour work with the second yarn guide to call up the selected needles moved into working position 2.

B. NEUTRAL POSITION

It is the MOST FREQUENT position.

C. LOWER POSITION

It is used to automatically call back the needles previously moved into holding position.

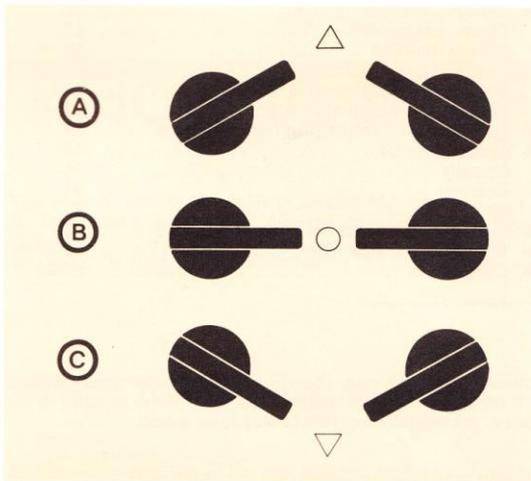

The locking levers

These levers:

- assure the stability of the carriage on the slide rail,
- securing the carriage onto the needle bed,
- permit the release of the carriage when jammed during knitting.

To release the carriage jammed during knitting, lift both locking levers, tilt the carriage backwards and move it back to the start of knitting.

When using both carriages, it is necessary to release first the back carriage.

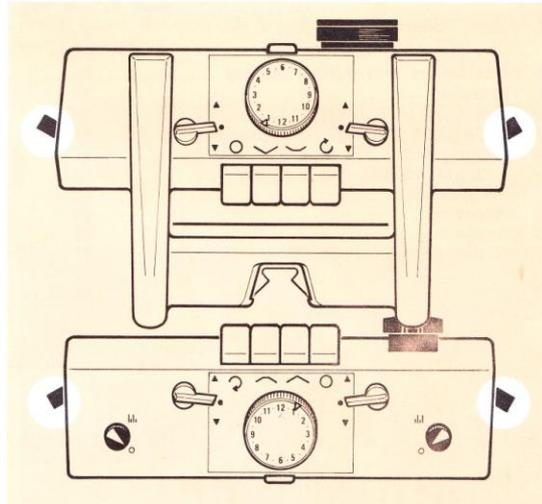

The needle selection buttons

These buttons only exist on the front carriage.

To obtain the required position, press the buttons down and turn.

A. UPPER POSITION

It is used to knit fancy stitches in 1/1 rib and Close rib (Jacquard) and for knitting on front bed only by selecting every other needle.

B. LOWER POSITION

It is used for NORMAL KNITTING.

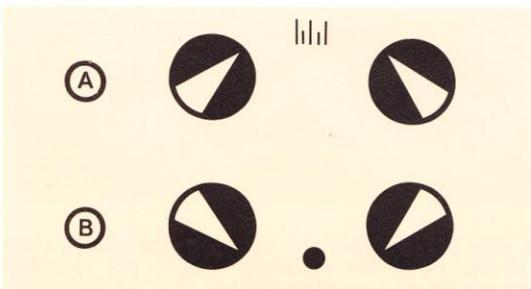

The brushes (A)

These are found under the handle of the carriage. They open the needle latches during knitting.

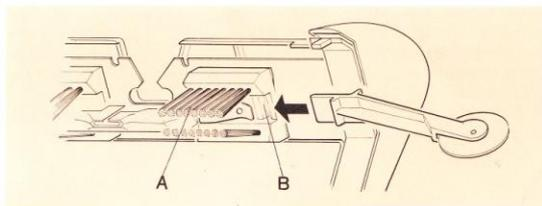

The spring clips (B)

These are located under the brushes and are used:

1. To fix the pushing-down wheels to knit rib with thick yarn.
2. To fix the Jacquard claw.
3. To fix the weaving effect brushes.

The row counter

- To bring back numbers to 0, turn the exterior button clockwise without touching the intermediary disc. This one turns in both directions and changes the numbers individually.
- To subtract, turn it towards you.
- To add, turn it away from you.

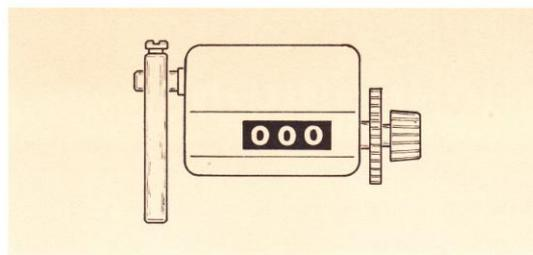

Stage one

	Page		
● Hints before and during knitting	14	● Straight vertical opening	21
● Threading	15	● Chain casting-off	22
● Casting-on in 1/1 simple rib	16	● During knitting	22
● Transferring from rib to stocking stitch	17	● Needle bed opening	23
● Stocking stitch	17	● Undoing one or several rows	23
— Chain casting-on	18	● Picking up dropped stitches	23
— Mock rib	18	● To remove or rehang half-knitted work	24
● Increasing	19	● Assembling	24
● Decreasing	19	Sewing	24
● Needles in holding position	20	Grafting	24
Part-row knitting	20	Finishing	24
● Necklines	21-22	● Garments made to measure	25
Armholes — Shoulders	21	● Test sample, size chart	26-27
		● Conversion table	28-29

Hints before and during knitting

Before knitting :

- 1. The machine must be set on an absolutely even and steady table.
- 2. When preparing the knitting, be careful that the needles are well centred on the machine, i.e., cast-on an equal number of needles on either side of 0. This will make the counting of stitches easier when increasing and decreasing.
- 3. If you are using the long mounting comb, present it with the hollow part facing you.

During knitting :

- 4. Move the carriage without pressing on the handle.
- 5. Never reverse the carriages when they are already engaged on needles in working position.
- 6. Watch your yarn: a ball empties quickly when knitting does not need any other intervention.
CAUTION: Never pass the carriage across without yarn, otherwise the knitting will drop from the machine.
- 7. Do not push the carriage too far beyond the fast working needle. A clicking noise tells you when the last needle has been knitted.

If during different operations, the carriage has to be moved up to the end of the needle bed, do not forget before

14

knitting the next row, to pull slightly on the yarn (behind the tension rod) to correct the tension. If the tension is too loose, you might drop stitches or form loops.

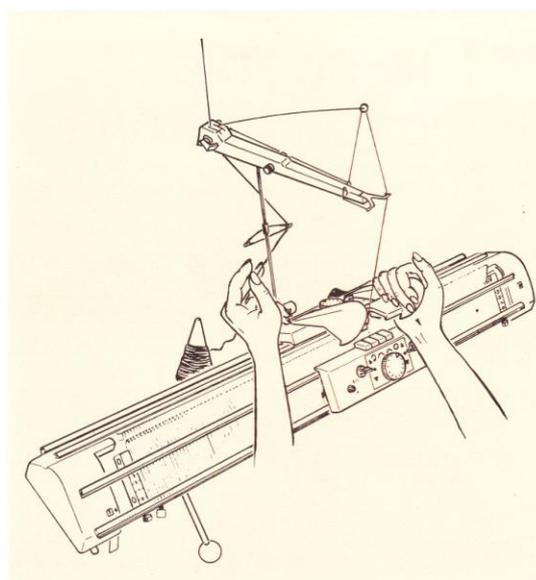

- 8. In order to avoid knots in your knitting when a ball empties, attach the remaining yarn to the stud and rethread the machine with a new ball.

- 9. Do not forget to loosen the yarn from the stud after a few rows.

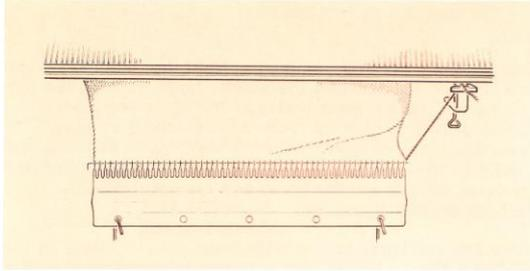

- 10. If you had to release the carriage during knitting, never try to put it back on needles in working position.
- Undo the row being knitting and before continuing with the knitting, make sure the carriage is locked on the end of the slide rail.

- 11. Watch the edge stitches; if they are not forming correctly, hang the edge claws.

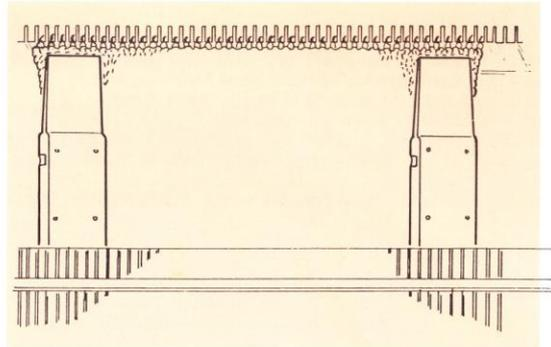

- 12. Move the carriage slowly across empty needles in working position.

How to thread the machine

The tension unit is foreseen to thread two yarns.

- To thread one yarn only, use the right side of the tension unit.
- Place the yarn on the table behind the tension rod.

How to fit the tension unit :

- Place the end «A» of the rod into the tension unit stand.
- Clip the feeding guide «C» onto the rod.
- Fit the tension head onto the end «B» of the rod.

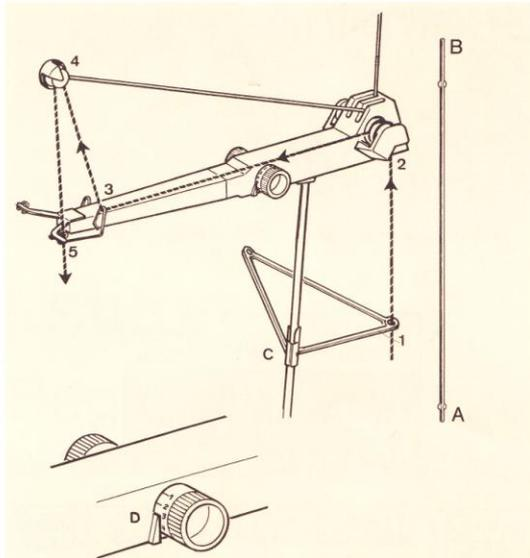

Pass the yarn :

1. Into the feeding guide.
2. Between both metallic discs.
3. Under the shaped guide.
4. On the wheel.
5. In the last guide.
6. Between both needle beds or over the needle bed of the single bed.
7. Fasten the end of the yarn to the stud located on the single bed.
8. In the yarn guide of the back carriage.

How to adjust the tension of the yarn:

The tension of the yarn can be adjusted by turning the knob «D», mark on figures 1, 2, 3 for thin yarns, mark on a higher figure for thicker yarns.

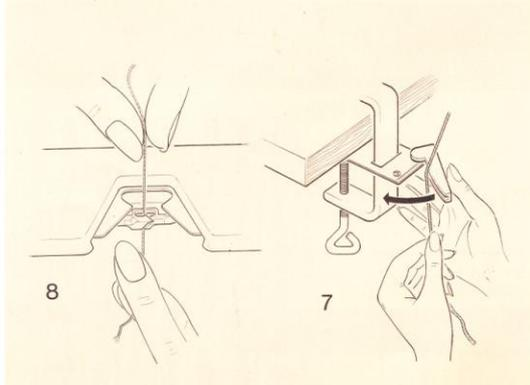

Casting-on in 1/1 simple rib

After threading the machine, with flow combs opposite and with carriages to the right-hand side →, set:

- Space selector according to thickness of yarn,
- Front bed in normal position 1.

Using the needle selector (see accessories, page 7) move on both needle beds every other needle in working position 1, as follows:

Make sure there is an equal number of needles on either side of 0:



! = needle in working position 1
 - = needle in non-working position 0

Settings on both carriage: Selection key: 
 Stitch size dial: 1
 Needle return buttons: neutral position

Settings on front carriage: Needle selection buttons: lower position

Move the carriages from right to left-hand side ←.

Remove the mounting comb wire. Hold the mounting comb and place it up between the needle beds through the zig-zag formed by the yarn (balance the mounting comb: the centre of it is shown by tooth of a different colour).

Pass the yarn between the comb teeth right after the last needle in working position to hold the last stitch. Replace the comb wire, lower the comb and hang weights.

Settings on both carriages: Selection key: 
 Stitch size dial: 3

Move the carriages to the right-hand side →, then to the left-hand side ← (In circular, a to-and-fro movement = one row).

Following rows: Selection key: 
 Settings on both carriages: Stitch size dial: 1/1 rib
 Needle return buttons and Needle selection buttons: same position

Set row counter to 000, unfasten the yarn from the stud and knit the required number of rows. All these explanations are shown by the following charts:

Beginning :

Space selector: 1/1 rib
 Intermediary lever: to the left-hand side.
 Racking lever: set needles and flow combs opposite.
 Carriages: to the right-hand side.

Casting-on :

Place mounting comb, wire and weights.
 See page 36 and 37 for other methods (do not forget the last loop).

NEEDLE BEDS	NEEDLES	POSITION
BACK	•••••	
FRONT	•••••	No 1 Normal

BACK				→
FRONT				←

1st and following rows :

Set row counter to 000 and unfasten the yarn from the stud.

CARRIAGES	KEY	STITCH	N.B.B.	N.S.B.	MOVEMENT
BACK			•••••		
FRONT			•••••	•••••	←

BACK		1/1 RIB		
FRONT		1/1 RIB		KNIT

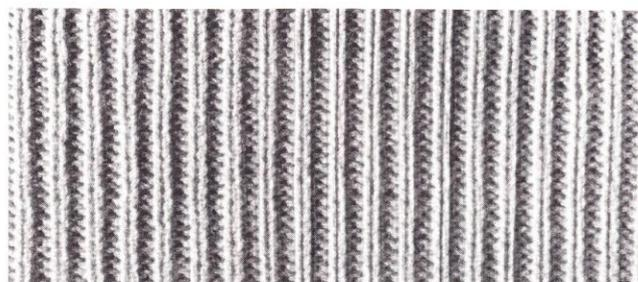

Transferring rib to stocking stitch

Using the Double Ended Eyelet needle transfer the front bed stitches onto the empty back bed needles.

Procedure :

A.
Hold the double ended eyelet needle in line with the front bed needle, open the needle latch, place the eyelet into the needle hook.

B.
Pull the needle up to holding position 3: the stitch slides behind the latch.

C.-D.
Keeping the tool on the needle hook in line with the needle, push the needle down into non-working position 0. Remove the tool from the front bed needle and tilt the tool backwards: the stitch is now on the tool.

E.
Place the other end of the tool onto the opposite needle hook on the back bed. Pull the needle slightly, tilt the tool and tip the stitch onto the needle hook.

Repeat the above actions until all front bed stitches are transferred onto the back bed needles.
Check that all the front bed needles are in non-working position 0.

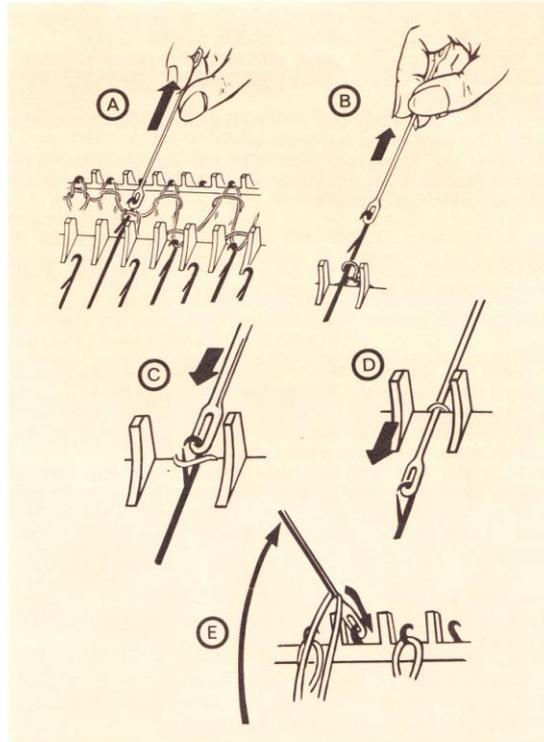

Stocking stitch

Increase needle bed spacing at least one millimetre in comparison with the ribs.

Remove FRont carriage.
Place FRont bed in upper position 2, to do this, use the bed position levers (see page 10) and lift the FRont bed.
Selection key: 
Stitch size dial: stocking stitch.
Needle return buttons: Neutral position.
See opposite chart.

Begin :

Space selector: stocking stitch (remove front carriage).

1st and following rows :

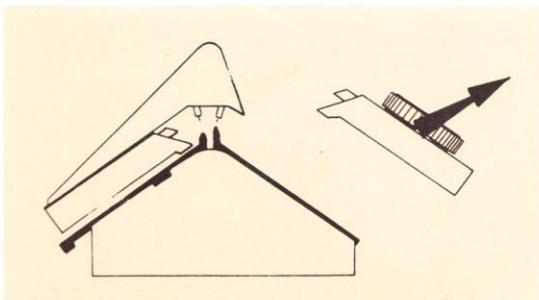

NEEDLE BEDS	NEEDLES	POSITION
BACK		
FRONT	No. 2 UPPER

CARRIAGES	KEY	STITCH SIZE	N.R.B.	N.S.B.	MOVEMENT
BACK		Stocking stitch			KNIT

Increasing in stocking stitch

Increasing one stitch

● On the carriage side of the knitting, bring one needle in working position 1. When the carriage passes this needle will be knitted.

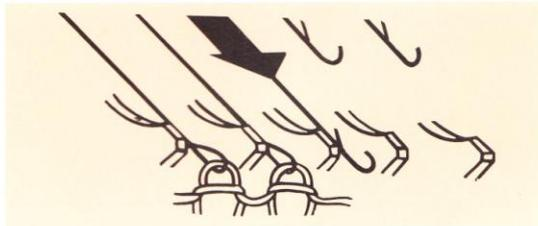

Increasing several stitches

- Quick increasing:
- On the carriage side, move into working position 2 with latches open, the number of needles to be increased.
- Pass the yarn under and over each empty needle, making sure the yarn lays under the last needle as illustrated below.
- Knit one row, lower the front bed and hang edge weights and claws on the new stitches.
- Place the front bed into upper position No 2.

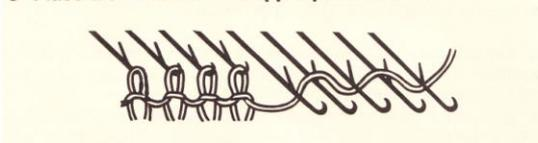

Decreasing in stocking stitch

Decreasing one stitch

This decrease can be done at each end of a row the same time.

- Using the single eyelet transfer tool, transfer the last stitch onto the next needle.
- LOWER THE EMPTY NEEDLE INTO NON-WORKING POSITION 0.

Decreasing several stitches

This decrease is made on the carriage side of the knitting.

- Using the single eyelet transfer tool, transfer the last stitch onto the next needle (A).
- Raise the needle with the two stitches to allow the stitches to slide behind the latch (B).

Increasing “chain casting-on”

It is made on the carriage side with FRont bed in lower position.

- Move into holding position 3 with latches open, the number of needles to be increased.
- Hold the yarn above the needles.
- Hold the latch needle tool above the needle bed, take the last stitch with hook and pull it between the two following needles.
- Push the tool up to allow the stitch to slide behind the latch. Catch the yarn and draw it forward to form a new stitch (A and B).
- Repeat the above actions across the required needles.
- Place the last stitch onto the last needle, making sure the yarn passes under the needle (C).
- Hang an edge claw onto the new stitches (see accessories, page 5).
- Place the FRont bed into upper position.
- Set the needle return buttons on the BACK Carriage into lower position.

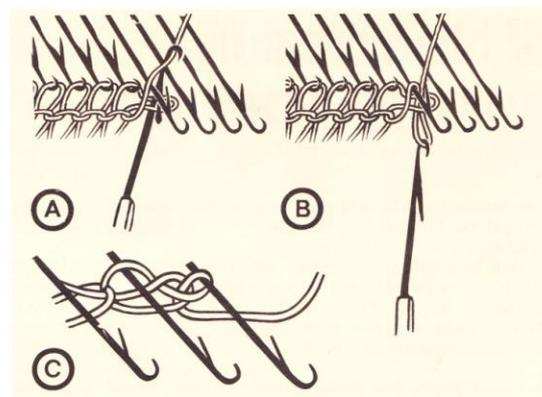

- Place the yarn into the needle hook by hand (C).
 - Lower the needle pulling the yarn through both stitches so that the new stitch is formed (D).
- Repeat this until the required number of stitches have been decreased.

NOTE: Do not forget to lower empty needles into non-working position 0.

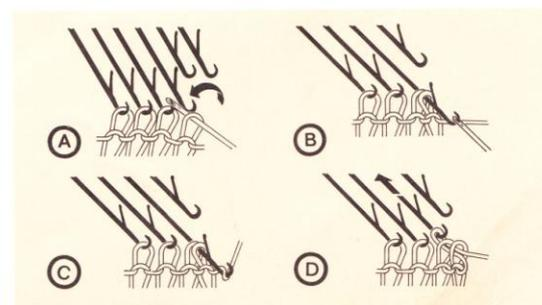

Decreasing “chain casting-off”

It is made on the opposite side of the carriage with front bed in lower position.

- Using the left hand, hold the base of the stitches to make the operation easier.
- Using the hook of the latch needle tool, take the first stitch, unhook it from the needle to make it slide behind the latch of the tool. Place your finger on the latch to keep it open (A).
- Take the next stitch and unhook it from the needle (B).
- Pull the tool to draw the second stitch through the first stitch (C).
- Repeat this operation as required and transfer the last stitch formed by the hook onto the last needle in working position.
- Do not forget to lower the empty needles into non-working position 0 and place the front bed into upper position.

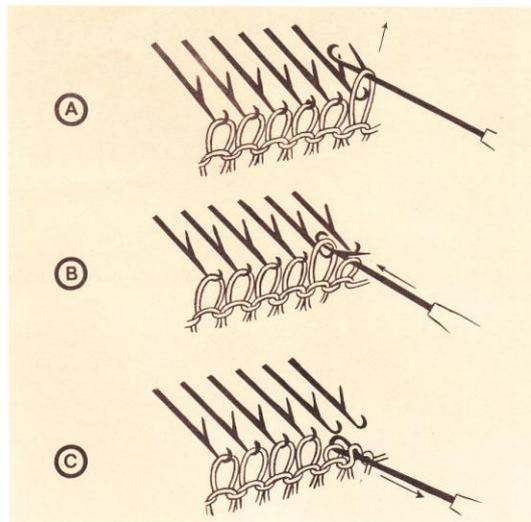

Needles in holding position

The holding position 3 means that the needles are at the highest position on the needle bed. The needle heels rest against the upper slide rail.

In this position the needles which carry stitches do not knit but can be recalled into working position when required (eg. buttonholes).

To call back needles from holding position into working position, there are two methods:

- either place the needles into working position 2. This is only possible for part of needles which are in holding position.
- or knit the next row with needle return buttons set in lower position. This is only possible when recalling all the needles which are in holding position.

With needles in holding position you may also knit part-row knitting.

Part-row knitting

This is used to make horizontal darts, shoulder shaping, heel shaping for socks, curves, for skirts and dresses, etc... Part-row knitting is obtained by placing individual needles or needle groups into holding position 3.

- On the side opposite to the carriage, bring into holding position 3 the needles required for holding less one, i.e. for 5 needles, move only 4 into position.
- Move the carriage across and bring into holding position one needle, i.e., the one omitted above. This will prevent a hole on the second row. Knit this second row.
- Repeat equally this operation to the required depth of the dart.
- Bring all needles back into working position.

NOTE: Make sure that the edge claws are moved gradually during knitting.

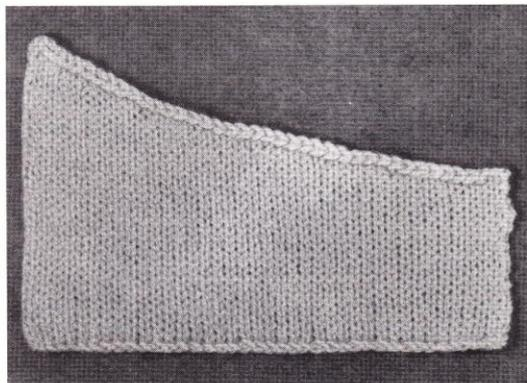
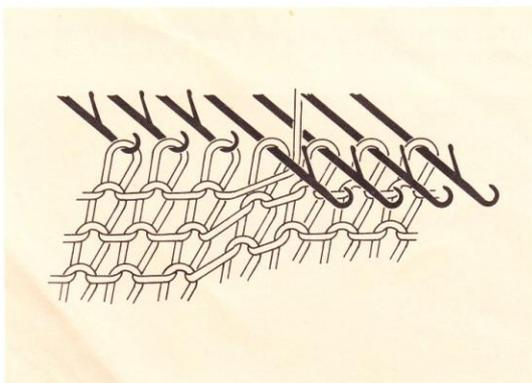

Necklines - Armholes - Shoulders

A - Straight vertical opening

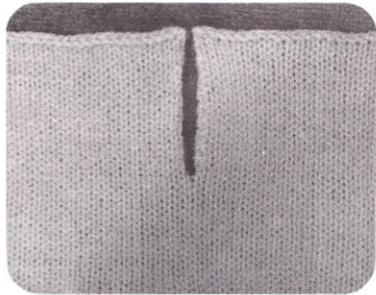

- On the side opposite to the carriage, bring into holding position 3 half the needles and knit on the remaining needles, until the required length for the zip is obtained.

This opening is also used for a shirt neck opening onto which the buttonhole band would be sewn.

- In this case it is important to decrease on each side at the beginning of the opening, the number of stitches corresponding to half the width of the buttonhole band. Knit straight.
- If you have an uneven number of stitches, proceed as for the V neckline (see below).

NOTE: Do not forget to hang edge claws on the first side to be knitted.

B - V. neckline

- On the side opposite to the carriage, bring into holding position half the needles of the knitting. Should you have an uneven number of needles, decrease on half the needles + one; when knitting the second side, add one stitch at the beginning of the opening.
- On the side on which you are knitting, proceed as follows:

Neckline side :

- Work out the depth of the neckline and according to it, decrease in the centre one stitch every 2, 3, 4, 5, 6 or 8 rows. The more rows you have between the decreases, the deeper the neckline will be.



Shoulder side :

Make shoulder shaping either by decreasing or shortened rows.

NOTE: On the first side of decreasing, it is necessary to use edge weights and claws to ensure an even descent of the knitting.

C. - Curved neckline

Separate the stitches as for the V neckline and commence shaping.

Neck side :

- Decrease as follows:

Example:

- Once 6 stitches — Knit 2 rows
- Once 5 stitches — Knit 2 rows
- Once 4 stitches — Knit 2 rows
- Once 3 stitches — Knit 2 rows
- Once 2 stitches — Knit 2 rows
- Once 1 stitches — Knit 2 rows

NOTE: It is not always necessary to divide the neckline from the centre. It is also possible to shape the neckline according to the second diagram below.

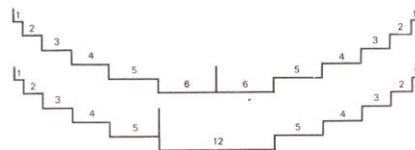

Armhole side :

Some examples of progression:

- for 10 stitches decrease:

- once 4 stitches
- once 3 stitches
- once 2 stitches
- once 1 stitch

- for 15 stitches decrease:

- once 4 stitches
- once 3 stitches
- once 2 stitches
- four times 1 stitch.

In any case you must always work out the depth of the armhole.

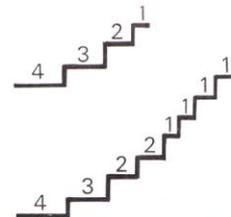

Curved neckline with needles in holding position

It is achieved by part-row knitting. This method gives a soft neckline and enables you to knit the neckband immediately on from the shaping.

- Proceed as for a normal curved neckline, but instead of casting-off the stitches, bring the number of needles necessary for each decrease into holding position 3.
- Continue knitting and make the shoulder shaping.
- To knit the second side:
 - Thread the carriage on the armhole side.
 - Lower into working position 2 the needles of the second side, less those corresponding to the first decrease, i.e., 6 stitches.
 - Continue as for the first side.
 - Then transfer onto the empty needles next to those with the stitches of the neckline, the necessary edge stitches which are between the neckline and the shoulder shaping.
 - Bring all needles into holding position 3.
 - Needle return buttons in lower position.
 - Knit one row.
 - Cast off, or if required, set the stitches to knit the neckband in rib.
 - Knit the necessary number of rows for the neckband and cast-off.

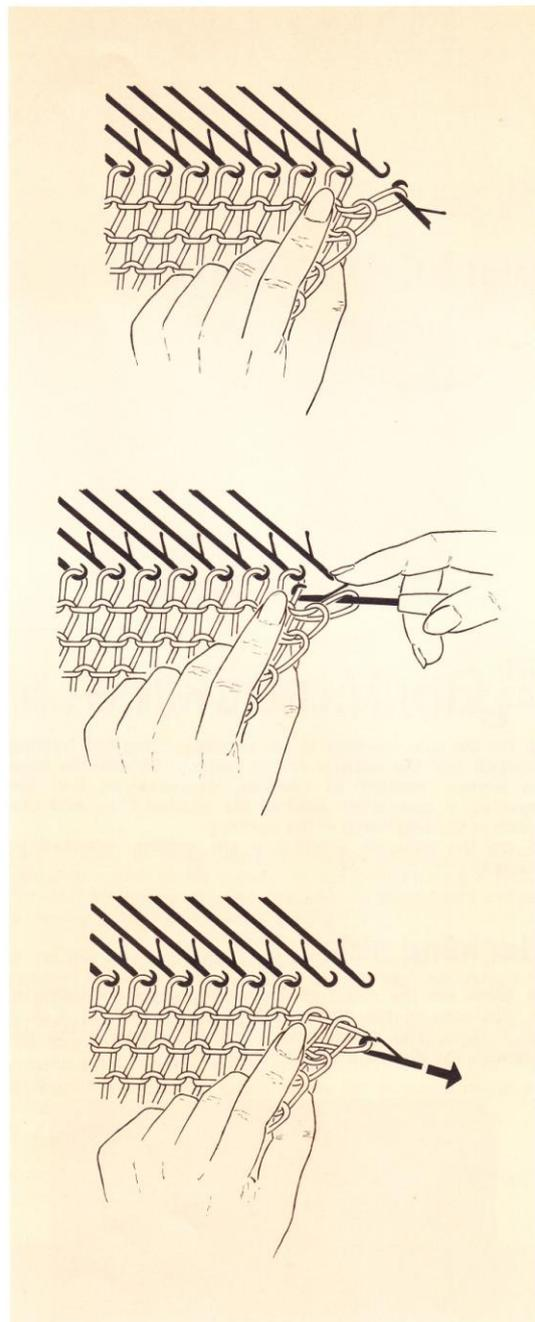

Chain casting-off

- On back bed.
- Carriage on the right-hand side or on the left-hand side if you are left-handed.
- Increase the stitch size by at least half.
- Knit one row.
- Remove some weights, making sure the mounting comb is evenly balanced.
- Lower the front bed.
- With the left hand, hold the knitting as illustrated.
- Pull slightly on the knitting to open the stitches.
- On the side opposite to the yarn, unhook the first stitch with the latch needle tool.
- Make this stitch slide behind the latch of the tool.
- Keeping the latch open, unhook the second stitch.
- Pull the tool to draw the second stitch through the first stitch.
- Repeat this action until all stitches are cast-off.
- Break the yarn and pull it through the last stitch.

During knitting

Each knitter and particularly a beginner may be distracted or make a mistake. In this case, it is easy to rectify. We are giving you the remedy in the following information. Further useful advice may be found on pages 69 and 70.

Needle bed opening

It is possible during knitting to view the work. Open the machine by lowering the front needle bed (lower position 4); the front bed needles will move on the needle beds. After checking, place the front bed into normal working position; the needles will be then in semi-holding position and semi-working position. To bring those needles back into working position, rehang the stitches into the needle hooks.

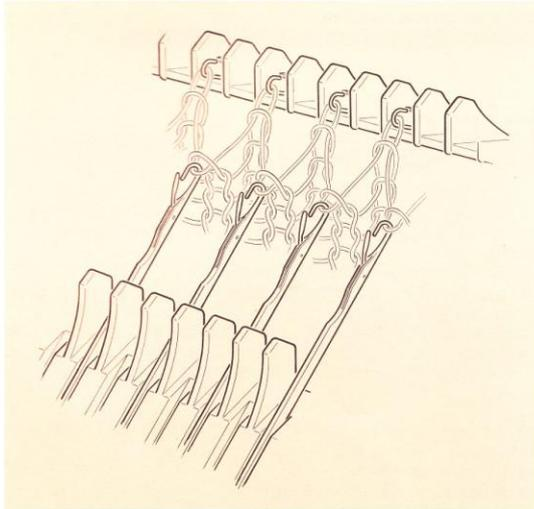

Undoing one or several rows

After the last knitted stitch, pull horizontally on the yarn to tighten it. Pull then vertically jerking the yarn to tilt the stitches of the previous row into the needle hooks. If you have an uneven number of rows to undo, the yarn will consequently be on the side opposite to the carriage. In this case proceed as follows: Cancel keys  and move the carriage across. Deduct from the row counter the number of rows you have undone. Reset the appropriate key.

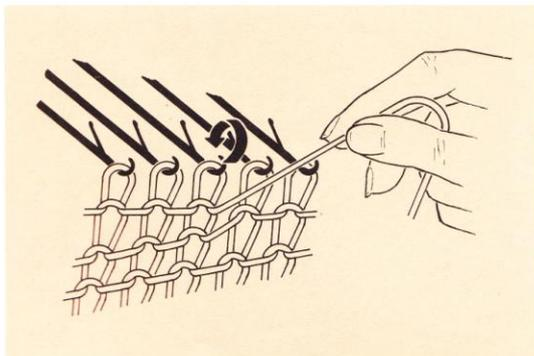

A stitch drops one row :

- Place the front bed into intermediary position.
- Place the dropped stitch and the loop onto the needle.
- Slide the stitch behind the latch.
- Place the loop into the needle hook.
- Pull the needle downwards by the heel to form the stitch.
- Place the front bed back into position.
- Continue to knit.

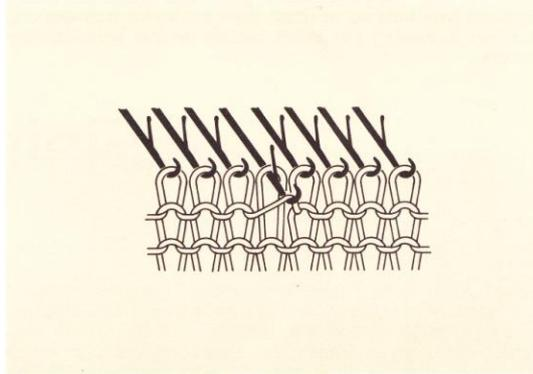

A stitch drops several rows :

- Lower the front bed.
- Insert the latch needle tool a few rows below the dropped stitch, in the back of the knitting if the stitch has dropped from the back bed and in the front of the knitting if the stitch has dropped from the front bed.
- Move the tool to make the stitch slide behind the latch.
- Take the yarn from the next row into the hook.
- Pull the tool downwards until the latch closes and a new stitch is formed.
- When the last stitch is formed, place it onto the single eyelet tool and transfer it onto the needle.

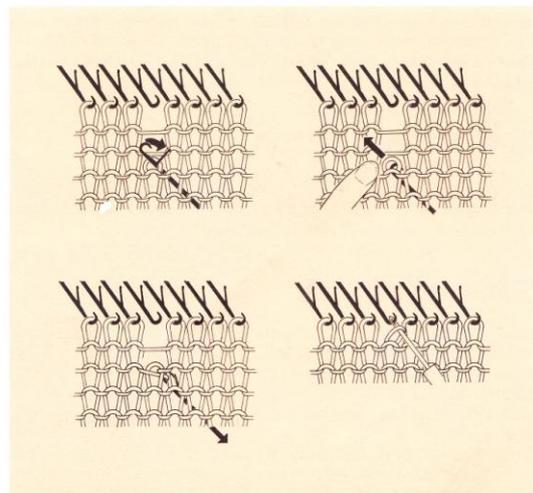

Removing or re-hanging a half-knitted work

To remove a half-knitted work from the machine :

Lower the front bed.

Take a hand-knitting needle and hold it above the machine. Insert it into the first stitch, push the machine needle upwards into holding position then back into non-working position 0, leaving the stitch resting on the hand-knitting needle.

To re-hang a half-knitted work onto the machine :

Place the stitches of the work onto a hand-knitting needle, then hold it level with the **flow combs**, front bed in lower position. Using the hook of the latch needle tool transfer the stitch from the hand-knitting needle one by one onto the appropriate needles.

Place the front bed into the required position.

Finishing

Pressing

Before assembling the different parts of your garment, it is necessary to press them. For even patterns like stocking stitch pin each part of the knitting with the wrong side uppermost onto an ironing table, placing the pins along the edges every 1 to 2 cm. Take care not to pull the garment out of shape nor to press the rib.

It is advisable to follow any instructions given on the yarn label. In general, pressing should be done with a damp cloth.

- Use a damp cloth and a low heat,
- gently place the iron without pressing on it to avoid crushing the knitting,
- remove the pins only after the damp resulting from pressing has evaporated and the pieces are dry. The knitting will then remain in shape ready for assembly,

Assembling

A knitted garment should be made up as carefully as a woven fabric. Considering that each piece corresponds

to the shape of a pattern, it is necessary to proceed as follows in order to acquire perfect seams:

- pin the parts together,
- proceed to try on each part,
- baste carefully parts together,
- try the garment on,
- sew the garment using one of the suggested methods below.

Seams

1. Invisible seam :

Join the edges stitches either on the wrong or the right side using a matching yarn and stitch once through the right-hand edge and once through the left-hand edge a.s.o.

2. Mattress stitch :

On the right side of the knitting, slightly inside the edges, stitch with a matching yarn once through the right-hand part and once through the left-hand part a.s.o.

3. Grafting :

This simple method is used to assemble two rows of open stitches. Grafting is mainly done with a matching yarn either on the right or the wrong side.

The stitches must be formed by a to-and-fro movement repeating operations C. and D.

24

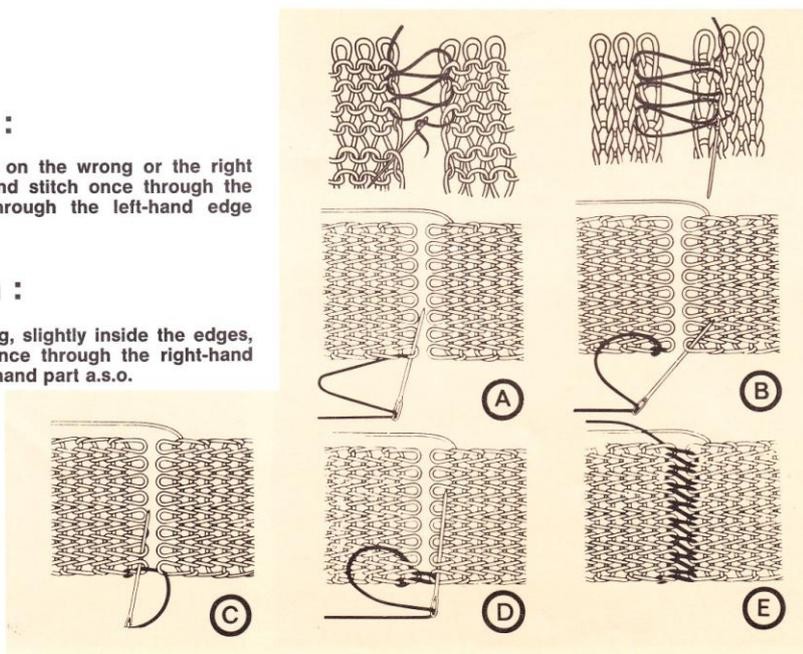

Garments made to measure

It could be necessary to increase the sizes from one to several centimetres in order to obtain a comfortable garment.

Example: it is advisable to increase the front and back breadth across the shoulders about 2 cm.

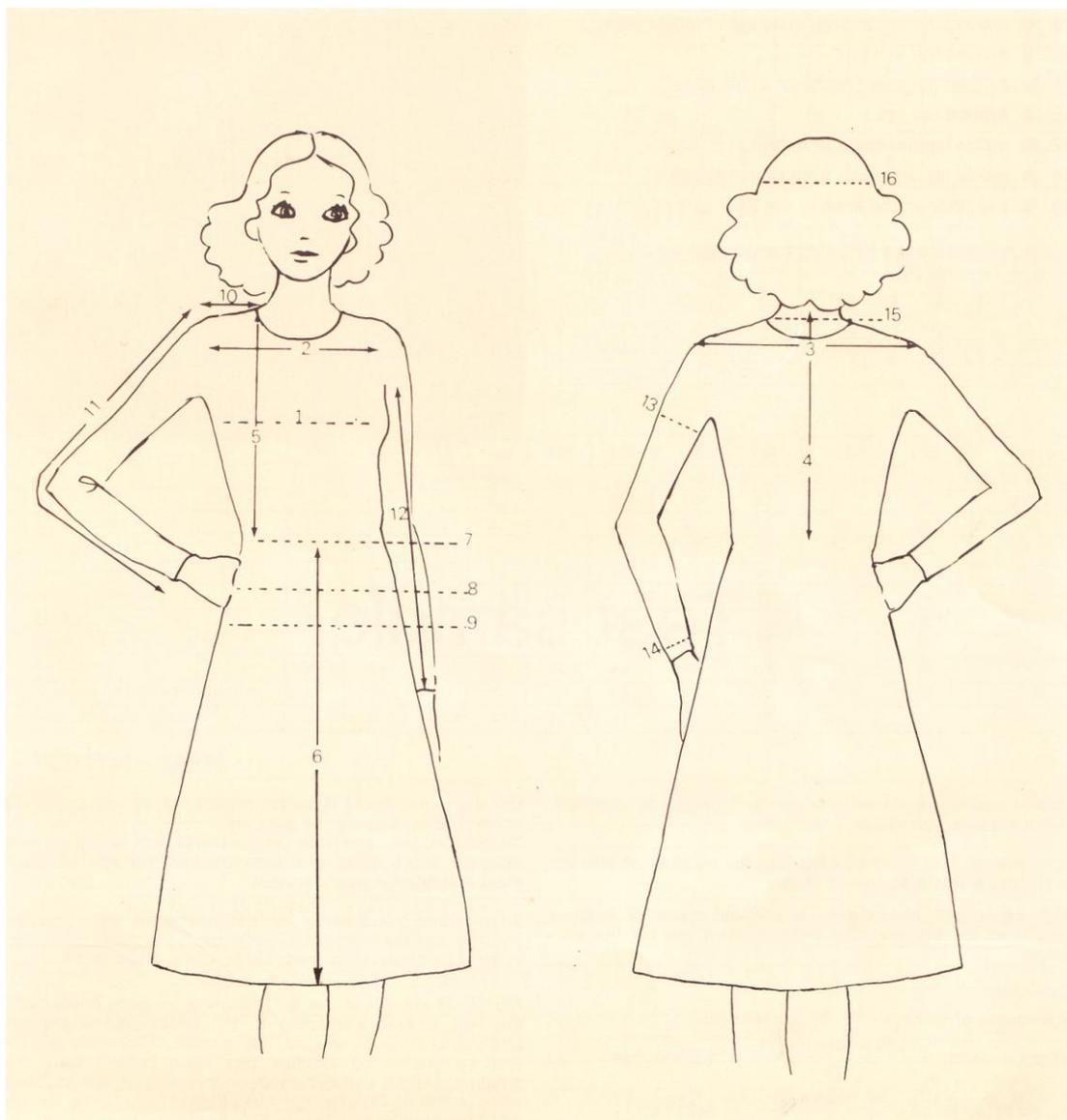

1. ● Around the bust;
2. ● Breadth of front shoulders: measure from armhole to armhole, half way between armhole and shoulder;
3. ● Breadth of back shoulders: measure from the edge of one shoulder to the other;
4. ● Depth from back neck to waist;
5. ● Depth from front neck to waist: measure from neck edge to waist;
6. ● Length of skirt: measure from centre front waist to required length;
7. ● Around the waist;
8. ● Around the hips; at 12 cm from the waist for ladies;
9. ● Around the lower hips; at 22 cm from the waist for ladies;
10. ● Shoulder width;
11. ● Outside length of arm: measure when slightly bent;
12. ● Inside length of arm: measure when outstretched;
13. ● Around the upper arm: measure at fullest point;
14. ● Around the wrist;
15. ● Around the neck: measure at the base;
16. ● Around the head;
17. ● Inside leg: measure from crotch to floor;
18. ● Inside leg: measure from crotch to ankle;
19. ● Length from the knee to the floor.

For trousers, take the following measurements:
7 - 8 - 9 - 17 - 18 - 19.

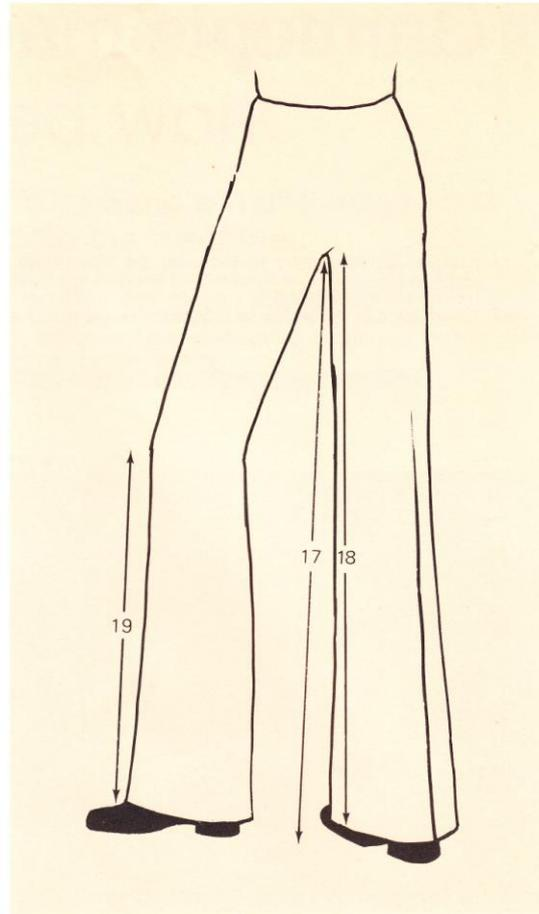

Test sample

Before knitting a garment, either by hand or by machine, it is advisable to knit a test sample.

It allows on one hand to calculate the number of stitches and rows within a square of 10 cm.

This procedure makes the conversion easier of stitches and rows for the measurements worked out for the garment.

Example:

if a square of 10 cm = 30 stitches/40 rows

$$45 \text{ cm in width} = \frac{30 \text{ stitches} \times 45}{10} = 135 \text{ stitches}$$

$$60 \text{ cm in length} = \frac{40 \text{ rows} \times 60}{10} = 240 \text{ rows}$$

26

On the other hand it helps sometimes to work out the correct stitch size for the garment.

To find it out, you can knit several test samples with different stitch sizes and then choose the one which is most suitable for your garment.

To produce good samples, it is necessary to follow the knitting and finishing procedures, to let the samples settle at least 24 hours, then press them with a damp cloth.

NOTE: There could be a difference in comparison with the test sample according to the width of the garment and the number of weights being used. If for instance the test sample of 50 stitches has been knitted with one medium weight, use two medium weights for 100 stitches, three medium weights for 150 stitches, one large weight and two medium weights for 180 stitches.



Sizes

GIRLS - LADIES

Sizes	34 N	36 N	38 N	40 N	42 N	44 N	46 N	48 N	50 N	52 N	
To fit bust in cm	81	84	87	90	93	96	99	102	108	114	
To fit waist in cm	53/56	57/60	61/64	65/68	69/72	73/76	77/80	81/84	89/92	97/100	
Around lower hips in cm	89	92	95	98	101	104	107	110	113	116	
Breadth of back shoulders in cm	36	36,5	37	37,5	38	38,5	39	40	41	42	
Breadth of front shoulders in cm	32	32,5	33	33,5	34	34,5	35	36	37	38	
Depth from neck to waist in cm	39,5	39,75	40	40,25	40,5	40,75	41	41,25	41,50	41,75	
To fit hips in cm	86	89	92	95	98	101	104	107	113	119	
Length of dress in cm	90	91	92	93	94	96	97	98	100	102	
Leng of skirt in cm	} Mini Normal Long	45	45	45	46	46	47	47	48	—	—
		—	49	50	51	52	53	54	55	58	58
		—	—	54	55	56	57	58	59	60	60
Length of coat in cm	92	93	94	95	96	98	99	100	102	104	
Depth of back armhole (front armhole + 1 cm)	15	15,5	16	16,5	17	17,5	18	18	18,5	18,5	
Minimum width of back and front neck base in cm	11	11	12	12	12	13	13	13	14	14	
Depth of back and front Shoulder in cm	4	4	5	5	5	5	5	5	6	6	

BABIES

Height	60 cm	67 cm	74 cm
Approximate age	3 months	6 months	1 year
Body length	26 cm	29 cm	32 cm
To fit waist	40 cm	44 cm	46 cm

INFANTS

Height	81	86	94
Approximate age	18 months	2 years	3 years
To fit chest in cm	50	52	54
To fit waist in cm	47	48	50
Lower body in cm	55	56	59
Length of dress in cm	40	42	46
Length of skirt in cm	17	19	22

CHILDREN

Height	102	108	114	120	126	132	138	144	150	156	162
Age	4years	5years	6years	7years	8years	9years	10 years	11 years	12 years	13/14years	15/16 years
To fit chest	56	58	60	62	64	66	70	74	78	82	86
To fit waist	52	53	54	55	56	57	58	59	60	61	62
Lower body	62	64	66	68	70	72	76	80	84	88	92
Breadth of back shoulders	24	24,8	25,6	26,4	27,2	28	29,2	30,4	31,6	32,8	34
Shoulder width	8,8	9,1	9,4	9,7	10	10,3	10,9	11,5	12,1	12,7	13,3
Waist to floor	63	67,2	71,4	75,6	79,8	84	87,7	91,4	95,1	98,8	102,5
Depth from neck to waist	23,8	25	26,2	27,4	28,6	29,8	31,6	33,4	35,2	37	38,8
Inside leg	44,5	48	51,5	55	58,5	62	65	68	71	74	77
Outside length of bent arm	36	38	40	42	44	46	48,5	51	53,5	56	58,5
Around base of neck	27,5	28,2	28,9	29,6	30,3	31	32	33	34	35	36

YOUTH - MEN

Size	Small	Medium	Large
To fit chest in cm	96/98	102/104	110/112
To fit waist in cm	84	88	96
To fit hips in cm	98	106	116

SOCKS

Length of foot	10,3	11	11,6	12,3	13	13,6	14,3	15	15,6	16,3	17	17,6	18,3	19	19,6
Shoe size	2	2 1/2	3	4	4 1/2	5 1/2	6	7	7 1/2	8 1/2	9 1/2	10	11	11 1/2	12 1/2
Length of foot	20,3	21	21,6	22,3	23	23,6	24,3	25	25,6	26,3	27	27,6	28,3	29	29,6
Shoe size	13	1	2	2 1/2	3 1/2	4	5	5 1/2	6 1/2	7 1/2	8	9	9 1/2	10 1/2	11

GLOVES

Around hand	17,5	19	20	21,5	23	24	25,5
Size	6 1/2	7	7 1/2	8	8 1/2	9	9 1/2

HATS

Age	4 months	9 months	1 year	3 years	5 years	7 years	9 years	11 years	13 years	15 years	Lady	Men
Around head	41,5	45	48	49	50	51	52	53	54	55	56	58

- **REFERENCE 2:** Choose in **ONE OF THE SIX VERTICAL COLUMNS «CMS» OF THE TABLE**, the necessary centimeters for your knitting.
 - Where these two lines cross in the table, you will find the result.
- If you desire the width, this result gives you the number of stitches or needles.

If you desire the length, this result gives you the number of rows to be knitted.
 Example: In order to knit a length of 25 cm with a sample of 15 rows for 10 cm, it is necessary to knit 37 rows. In order to knit a width of 20 cm with a sample of 12 stitches for 10 cm, it is necessary to cast on 24 stitches or needles.

cms										cms										cms									
10	33	34	35	36	37	38	39	40	41	42	43	10	44	45	46	47	48	49	50	51	52	53	54	10					
1	3	3	3	4	4	4	4	4	4	4	4	1	4	4	5	5	5	5	5	5	5	5	5	1					
2	7	7	7	7	7	8	8	8	8	8	8	2	9	9	9	9	10	10	10	10	10	10	11	2					
3	10	10	10	11	11	11	12	12	12	13	13	3	13	13	14	14	14	15	15	15	16	16	16	3					
4	13	14	14	14	15	15	16	16	16	17	17	4	18	18	18	19	19	20	20	20	21	21	22	4					
5	16	17	17	18	18	19	19	20	20	21	21	5	22	22	23	23	24	24	25	25	26	26	27	5					
6	20	20	21	22	22	23	23	24	25	25	26	6	26	27	28	28	29	29	30	31	31	32	32	6					
7	23	24	24	25	26	27	27	28	29	29	30	7	31	31	32	33	34	34	35	36	36	37	38	7					
8	26	27	28	29	30	30	31	32	33	34	34	8	35	36	37	38	38	39	40	41	42	42	43	8					
9	30	31	31	32	33	34	35	36	37	38	39	9	40	40	41	42	43	44	45	46	47	48	49	9					
10	33	34	35	36	37	38	39	40	41	42	43	10	44	45	46	47	48	49	50	51	52	53	54	10					
11	36	37	38	40	41	42	43	44	45	46	47	11	48	50	51	52	53	54	55	56	57	58	59	11					
12	40	41	42	43	44	46	47	48	49	50	51	12	53	54	55	56	58	59	60	61	62	64	65	12					
13	43	44	46	47	48	49	51	52	53	55	56	13	57	58	60	61	62	64	65	66	68	69	70	13					
14	46	48	49	50	52	53	55	56	57	59	60	14	62	63	64	66	67	69	70	71	73	74	76	14					
15	49	51	52	54	55	57	58	60	61	63	64	15	66	67	69	70	72	73	75	76	78	79	81	15					
16	53	54	56	58	59	61	62	64	66	67	69	16	70	72	74	75	77	78	80	82	83	85	86	16					
17	56	58	59	61	63	65	66	68	70	71	73	17	75	76	78	80	82	83	85	87	88	90	92	17					
18	59	61	63	65	67	68	70	72	74	76	77	18	79	81	83	85	86	88	90	92	94	95	97	18					
19	63	65	66	68	70	72	74	76	78	80	82	19	84	85	87	89	91	93	95	97	99	101	103	19					
20	66	68	70	72	74	76	78	80	82	84	86	20	88	90	92	94	96	98	100	102	104	106	108	20					
21	69	71	73	76	78	80	82	84	86	88	90	21	92	94	97	99	101	103	105	107	109	111	113	21					
22	73	75	77	79	81	84	86	88	90	92	95	22	97	99	101	103	106	108	110	112	114	117	119	22					
23	76	78	80	83	85	87	90	92	94	97	99	23	101	103	106	108	110	113	115	117	120	122	124	23					
24	79	82	84	86	89	91	94	96	98	101	103	24	106	108	110	113	115	118	120	122	125	127	130	24					
25	82	85	87	90	92	95	97	100	102	105	107	25	110	112	115	117	120	122	125	127	130	132	135	25					
26	86	88	91	94	96	99	101	104	107	109	112	26	114	117	120	122	125	127	130	133	135	138	140	26					
27	89	92	94	97	100	103	105	108	111	113	116	27	119	121	124	127	130	132	135	138	140	143	146	27					
28	92	95	98	101	104	106	109	112	115	118	120	28	123	126	129	132	134	137	140	143	146	148	151	28					
29	96	99	101	104	107	110	113	116	119	122	125	29	128	130	133	136	139	142	145	148	151	154	157	29					
30	99	102	105	108	111	114	117	120	123	126	129	30	132	135	138	141	144	147	150	153	156	159	162	30					
31	102	105	108	112	115	118	121	124	127	130	133	31	136	139	143	146	149	152	155	158	161	164	167	31					
32	106	109	112	115	118	122	125	128	131	134	138	32	141	144	147	150	154	157	160	163	166	170	173	32					
33	109	112	115	119	122	125	129	132	135	139	142	33	145	148	152	155	158	162	165	168	172	175	178	33					
34	112	116	119	122	126	129	133	136	139	143	146	34	150	153	156	160	163	167	170	173	177	180	184	34					
35	115	119	122	126	129	133	136	140	143	147	150	35	154	157	161	164	168	171	175	178	182	185	189	35					
36	119	122	126	130	133	137	140	144	148	151	155	36	158	162	166	169	173	176	180	184	187	191	194	36					
37	122	126	129	133	137	141	144	148	152	155	159	37	163	166	170	174	178	181	185	189	192	196	200	37					
38	125	129	133	137	141	144	148	152	156	160	163	38	167	171	175	179	182	186	190	194	198	201	205	38					
39	129	133	136	140	144	148	152	156	160	164	168	39	172	175	179	183	187	191	195	199	203	207	211	39					
40	132	136	140	144	148	152	156	160	164	168	172	40	176	180	184	188	192	196	200	204	208	212	216	40					
41	135	139	143	148	152	156	160	164	168	172	176	41	180	184	189	193	197	201	205	209	213	217	221	41					
42	139	143	147	151	155	160	164	168	172	176	181	42	185	189	193	197	202	206	210	214	218	223	227	42					
43	142	146	150	155	159	163	168	172	176	181	185	43	189	193	198	202	206	211	215	219	224	228	232	43					
44	145	150	154	158	163	167	172	176	180	185	189	44	194	198	202	207	211	216	220	224	229	232	238	44					
45	148	153	157	162	166	171	175	180	184	189	193	45	198	202	207	211	216	220	225	229	234	238	243	45					
46	152	156	161	166	170	175	179	184	189	193	198	46	202	207	212	216	221	225	230	235	239	244	248	46					
47	155	160	164	169	174	179	183	188	193	197	202	47	207	211	216	221	226	230	235	240	244	249	254	47					
48	158	163	168	173	178	182	187	192	197	202	206	48	211	216	221	226	230	235	240	245	250	254	259	48					
49	162	167	171	176	181	186	191	196	201	206	211	49	216	220	225	230	235	240	245	250	255	260	265	49					
50	165	170	175	180	185	190	195	200	205	210	215	50	220	225	230	235	240	245	250	255	260	265	270	50					
51	168	173	178	184	189	194	199	204	209	214	219	51	224	229	235	240	245	250	255	260	265	270	275	51					
52	172	177	182	187	192	198	203	208	213	218	224	52	229	234	239	244	250	255	260	265	270	276	281	52					
53	175	180	185	191	196	201	207	212	217	223	228	53	233	238	244	249	254	260	265	270	276	281	286	53					
54	178	184	189	194	200	205	211	216	221	227	232	54	238	243	248	254	259	265	270	275	281	286	292	54					
55	181	187	192	198	203	209	214	220	225	231	236	55	242	247	253	258	264	269	275	280	286	291	297	55					
56	185	190	196	202	207	213	218	224	230	235	241	56	246	252	258	263	269	274	280	286	291	297	302	56					
57	188	194	199	205	211	217	222	228	234	239	245	57	251	256	262	268	274	279	285	291	296	302	308	57					
58	191	197	203	209	215	220	226	232	238	244	249	58	255	261	267	273	278	284	290	296	302	307	313	58					
59	195	201	206	212	218	224	230	236	242	248	254	59	260	265	271	277	283	289	295	301	307	313	319	59					
60	198	204	210	216	222	228	234	240	246	252	258	60	264	270	276	282	288	294	300	306	312	318	324	60					
61	201	207	213	220	226	232	238	244	250	256	262	61	268	274	281	287	293	299	305	311	317	323	329	61					
62	205	211	217	223	229	236	242	248	254	260	267																		

Stage two

	Page		
● Casting-on in stocking stitch	30-32	● Circular stocking stitch	48
● Increasing in stocking stitch	32	● Semi-circular stocking stitch	49
● Decreasing in stocking stitch	33-34	● Thick yarn	50
● Casting-off	35	● Buttonholes	51
● Casting-on in 1/1 simple rib	36-37	● Hems	52
● Casting-on in 1/1 double sided Fisherman rib	38	● Hem-fold	53
● Casting-on in 1/1 single sided Fisherman rib	39	● Neckband	53
● Casting-on in 2/2 simple rib	40	● Pockets	54
● Casting-on in 2/2 double sided Fisherman rib	41	● Socks	55-56
● Casting-on in 2/2 Industrial rib	42	● Fair Isle	57
● Casting-on in 2/1 simple rib	43	● Norwegian Jacquard	58
● Mock rib	44	● Jacquard	59
● Increasing and decreasing in 1/1 simple rib	45	● Weaving effect	60
● Increasing in single and double sided Fisherman rib	46	● Racking pattern	61
● Decreasing in single and double sided Fisherman rib	46	● Fancy patterns	62-66
● Close rib	47	● Fancy ribs	66-68
		● Changing a needle	68
		● Maintenance and care	69
		● What to do if	69-70

Casting-on in stocking stitch

This method is suitable for test sample but remember that the stitches are open.

NOTE FOR SB:
● After having knitted 4 to 5 rows, fix the knitting retainer.

1. Open casting-on:

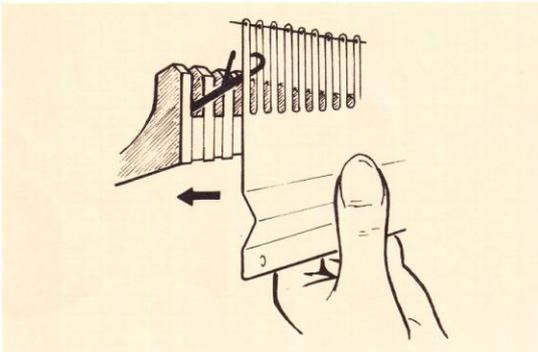

- Remove front carriage.
- Back carriage at right-hand side →, thread machine, fasten end of yarn to stud and using the needle ruler, move the required number of needles into working position 1.

● Space selector: set for stocking stitch.

Front bed normal position.

Settings on back carriage:

Selection key:

Stitch size dial as for stocking stitch.

Needle return buttons in neutral position.

- Take the mounting comb with wire with the tooth of a different colour in the centre facing you.
- Position the comb teeth against the back flow combs to allow the free movement of the needles and tilt the comb backwards.

- Move both end needles into working position 2 to steady the comb.
- Move the carriage to the left-hand side ←.
- Lower the comb.

Hang weights, place the front bed into upper position and set the row counter to 000.

- Knit →.

30

Beginning :

Space selector as for stocking stitch.
Remove front carriage.
Back carriage at the right-hand side.
Position the comb with wire against the back flow combs.

NEEDLE BEDS	NEEDLES	POSITION
BACK		
FRONT	No 1 Normal

CARRIAGES	KEY	STITCH	N.B.B.	N.S.B.	MOVEMENT
BACK		Stocking stitch	●●●		←

1st and following rows :

Hang weights and set row counter to 000.
Unfasten the yarn from the stud after a few rows.

BACK			KNIT
FRONT		No 2 UPPER	

2. Closed casting-on :

- Back carriage at the right-hand side → , thread machine, select every other needle into working position 1. The knitting begins on half the required number of needles.

- Settings and casting-on as for open casting-on.
- Lower the comb and hang weights.
- Move into working position 1 the remaining needles. The knitting will now include all the required needles. Place front bed into upper position and set the row counter to 000.
- Knit.

NOTE FOR SB.

- After having knitted 4 to 5 rows, fix the knitting re-tainer.

NEEDLE BEDS	NEEDLES	POSITION
BACK		
FRONT	No 1 Normal

CARRIAGES	KEY	STITCH	N.B.B.	N.S.B.	MOVEMENT
BACK	△	Stocking stitch	●●●		←

1st and following rows :

Hang weights and set row counter to 000.
Unfasten the yarn from the stud after a few rows.

Beginning :

Space selector as for stocking stitch.
Remove front carriage.
Back carriage at the right-hand side.
Position the comb with wire against the back flow combs.

BACK		
FRONT	No 2 UPPER

KNIT

Closed casting-on in stocking stitch by hand

- Thread the machine with an auxiliary yarn.
- Settings and casting-on as for above closed casting-on.
- Break the auxiliary yarn and fasten it to the stud.
- Cancel keys □ and move the carriage to the right-hand side →.
- Rethread the tension unit with the main yarn and fasten the end of the yarn to the left-hand stud. Lower front bed into intermediary position.
- Knit one row by hand as follows:
 - Move the first left-hand needle into working position 2, the stitch in auxiliary yarn slides behind the latch.
 - Pass the main yarn under the needle then back into the needle hook and again under the needle.
 - Pull the needle back to form a stitch.
- Repeat this operation loosely on all needles.
- Thread the main yarn into the carriage yarn guide.
- Place the front bed into upper position.
- Select on Back carriage key △ and set row counter to 000.
- Knit.
- When the knitting is finished, remove the auxiliary yarn.

NOTE FOR S.B.

- After having knitted 4 to 5 rows, fix the knitting re-tainer.

Beginning :

Space selector as for stocking stitch.
 Remove front carriage.
 Back carriage at the right-hand side.
 Use an auxiliary yarn to begin.
 Position the comb with wire against the back flow combs.

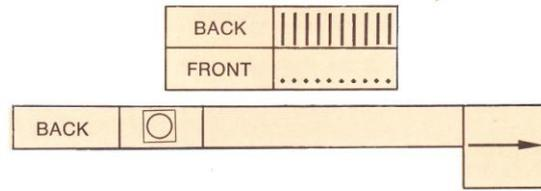

NEEDLE BEDS	NEEDLES	POSITION
BACK		
FRONT	No 1 Normal

CARRIAGES	KEY	STITCH	N.B.B.	N.S.B.	MOVEMENT
BACK	△	Stocking stitch	●●●●		←

1st and following rows :

Starting from the left-hand side, loop the main yarn as follows  and knit by hand each needle — thread the main yarn into the yarn guide — set row counter to 000 — needles in working position 1.

BACK	NEEDLES	POSITION
FRONT	No 2 UPPER

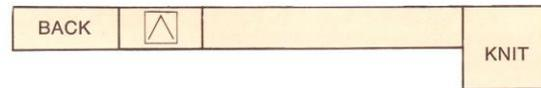

Casting-on :

Hang weights, break auxiliary yarn and fasten it to the left-hand stud. Needles in working position 2 — thread tension unit with main yarn.

Unfasten the main yarn after a few rows. After casting-off, remove auxiliary yarn.

Increasing in stocking stitch

Italian increase 3 sts in :

On each side:
 ● Using the 3 eyelet tool, transfer the three end stitches each along one needle.
 ● With the hook of the latch tool, hang the loop between the 3rd and 4th stitch onto the empty needle twisting it to prevent a hole on the next row.

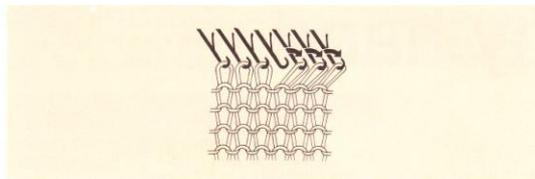

Mid-row increase 1 stitch :

To do this, a needle has to be emptied.
 ● Move all the stitches outwards to reach the needle where the increase is to be made.
 ● Take the heel of the next stitch and hook it onto the empty needle.

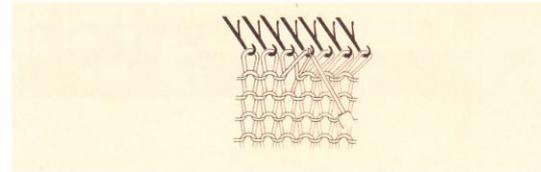

Italian increase 2 sts in :

On each side:
 ● Using the 2 eyelet tool, transfer the two end stitches each along one needle.
 ● With the hook of the latch tool, hang the loop between the 2nd and 3rd stitch onto the empty needle twisting it to prevent a hole on the next row.

Mid-row increase several stitches :

● Knit several rows with an auxiliary yarn.
 ● Break the yarn and move the carriage across to make the knitting drop from the machine.
 ● Rehang the knitting undoing the auxiliary yarn gradually, leaving empty needles for the increase.
 ● Take the heel of the next stitch and hook it onto the empty needle.

Decreasing in stocking stitch

Bias decreasing : Single Italian decrease 2 sts in :

● At the carriage side using the 6 eyelet tool, move the first six stitches inwards so that the 7th and 8th needles have two stitches.

● Place these two needles into working position 2.
● Lower the first empty edge needle into non-working position 0, the other one remains in working position 1.

● On both sides of the knitting, using the 3 eyelet tool, transfer the three end stitches one needle inwards.

Mid-row decrease 1 stitch

● At the place where the decrease is to be made, transfer one stitch onto the next needle.

● Move all the stitches inwards from the edge of the knitting to the centre.

● Lower the empty needle into non-working position 0, and knit.

Single Italian decrease 1 st in :

● On both sides of the knitting, using the 2 eyelet tool, transfer the two end stitches one needle inwards.

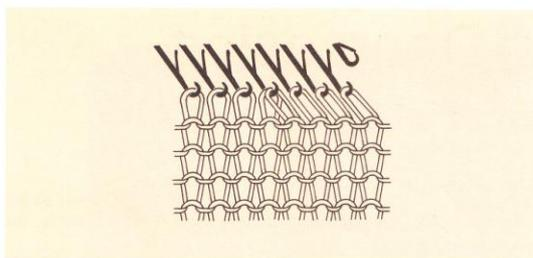

Double Italian decrease 3 sts in :

● On both sides of the knitting, transfer the 5th stitch onto the 6th needle, using the 6 eyelet tool, transfer the four end stitches two needles inwards (the 6th needle holds 3 stitches, move it into working position 2).

Mid-row decrease several stitches :

● Remove the knitting from the machine (remember auxiliary yarn).

● Rehang the knitting onto the machine placing two stitches on one needle where required.

Double Italian decrease 2 sts in :

● On both sides of the knitting, transfer the 4th stitch onto the 5th needle, using the 3 eyelet tool, transfer the three end stitches two needles inwards (the 5th needle holds 3 stitches).

Single Italian decrease 3 sts in : Fancy double Italian decrease 3 sts in :

● On both sides of the knitting, using the 6 eyelet tool, transfer the four end stitches one needle inwards.

● On both sides of the knitting, using the 6 eyelet tool, transfer the five end stitches two needles inwards.

Fancy treble Italian decrease 3 sts in :

- On both sides of the knitting, using the 6 eyelet tool, transfer the six end stitches three needles inwards.

Fancy treble “special effect” Italian decrease 3 sts in :

- On both sides of the knitting, transfer the 4th stitch onto the 5th needle, then using the 2 eyelet tool, transfer the stitches from the 5th needle and the 6th stitch onto the 7th and 8th needles, finally, with the 3 eyelet tool, transfer the three end stitches three needles inwards.

Fancy quadruple “special effect” Italian decrease 3 sts in :

- On both sides of the knitting, transfer the 4th stitch onto the 5th needle, then using the 3 eyelet tool, transfer the stitches from the 5th needle, the 6th and the 7th stitch onto the 8th, 9th and 10th needles, finally with the 3 eyelet tool, transfer the three end stitches four needles inwards.

The above methods have been selected by professional knitters. They result in neat edges and make the assembling of your garments easier. Invisible seams can still be obtained at the decreased edges.

Simple decrease: Decreasing several stitches

This can be made on both sides of the knitting.

- Using the single eyelet tool, transfer the second stitch onto the first needle.
- Transfer both stitches onto the second needle.
- Lower the empty needle into non-working position 0, and move the other needle into working position 2.

This can only be done on the carriage side.

- Using the single eyelet tool, transfer the second stitch onto the first needle and place both stitches onto the second needle.
- Move both stitches into working position 2: the stitches slide behind the latch.
- Lay the yarn in the needle hook as illustrated and pull the needle back into working position 1: a new stitch is formed.
- Repeat above action as required.

Do not forget to lower the empty needles into non-working position 0.

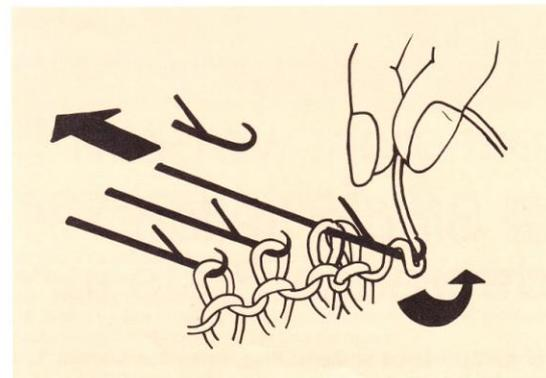
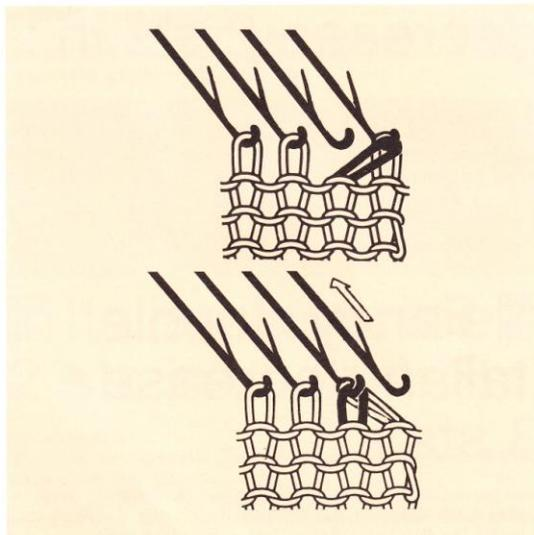

Casting-off

Stocking stitch

Method 1 :

Proceed as for «decreasing several stitches».
On the carriage side, transfer the last stitch onto the next.
Move the needle by hand to make the stitch slide behind the latch.
Lay the yarn in the needle hook and pull the needle back into working position 1.
Repeat above action until the last stitch.
To avoid tightening the stitches, hook the knitting onto empty needles.

Method 2 :

Front bed normal position. Place the equivalent number of needles on the front bed into working position 1.
Couple both carriages.
Intermediary lever to the right.
Racking lever 1 notch to the left-hand side. (Flow combs alternate).
Settings on both carriages:
Selection key: 
Stitch size: half the stocking stitch size. (Choose full number).
Move the carriages across: stitches are formed on the front bed. Separate the carriages and take the front carriage only back to release the front bed stitches.
Lower the front bed and using the latch needle tool chain cast-off beginning from the side opposite to the yarn leaving the stitches on the needles (as illustrated). At the last stitch, break the yarn and pull it through the last stitch. To release the knitting, place the front bed into normal position and pass the back carriage across.
Do not forget to reset the flow combs opposite.

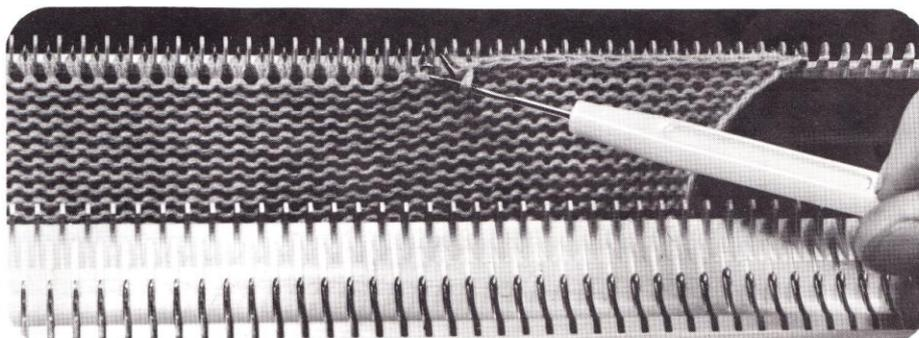

1/1 rib

Method 2 :

● In order to keep the continuity of the rib:
either cast-off the knitting keeping the sequence of the rib;
or knit the last row with a larger stitch size, then transfer the stitches onto empty back bed needles and cast-off.

Casting-on in 1/1 rib

Beginning for method 1 and 2

Pass the carriages from the right-hand side to the left-hand ←.
Hold the mounting comb and place it up between the needles beds through the zig zag formed by the yarn. Pass the yarn between the two last comb teeth at the left-hand side (a loop will be formed). Replace the wire and hang weights.

Carriages at the right-hand side and thread the machine.
Space selector as for 1/1 rib.
Front bed normal position.
Using the needle selector, place on both needle beds every other needle into working position 1 as follows.



Settings on both carriages:

Selection key 
Stitch size dial: 1.
Needle return buttons: neutral.
Needle selection buttons (front carriage only) in lower position.

Casting-on (for fine yarn) method 1

Move the front bed needles into holding position 3.
Pass the carriages from left-hand side to right-hand side →.
Needles return buttons on front carriage in lower position.
Settings on both carriages:
Stitch size dial set as for 1/1 rib.
Pass the carriages from right-hand side to left-hand side ←.
Needle return buttons on front carriage in neutral position.
Set row counter to 000, and knit.

Casting-on method 2

Selection key on back carriage: 
Selection keys on front carriage: (depress simultaneously both keys).  
Pass the carriages from the left-hand side to the right-hand side →, and then back ←.
Settings on both carriages:
Selection key: 
Stitch size dial set for 1/1 rib.
Set row counter to 000 and knit.

When the knitting is finished, pull on the loop when casting-on to bring the yarn to the side of the loop.

Casting-on in 1/1 rib method 1

Casting-on in 1/1 rib method 2

Beginning :

Space selector as for 1/1 rib.
 Intermediary lever to the left-hand side.
 Racking lever to obtain needles and flow combs opposite.
 Carriages at the right-hand side.

NEEDLE BEDS	NEEDLES	POSITION
BACK	• • • • • •	
FRONT	• • • • • •	No 1 Normal

CARRIAGES	KEY	STITCH	N.B.B.	N.S.B.	MOVEMENT
BACK	△	↻	• • • •		→
FRONT	△	↻	• • • •	• •	←

Beginning :

As for Method 1.

Casting-on :

Place mounting comb, wire and weights (do not forget the loop).

BACK	↻				
FRONT	↻				→

Set row counter to 000 and unfasten the yarn from the stud.

Casting-on

Place mounting comb, wire and weights (do not forget the loop).

BACK	• • • • • •
FRONT	• • • • • •

BACK					→
FRONT					
BACK		RIB 1/1	• • • •		
FRONT		RIB 1/1	• • • •		←

BACK	△	RIB 1/1			
FRONT	△	RIB 1/1			KNIT

1st and following rows :

Set row counter to 000 and unfasten the yarn from the stud.

BACK	• • • • • •
FRONT	• • • • • •

BACK		• • • •			
FRONT		• • • •			KNIT

Double sided Fisherman rib

Beginning :

Space selector as for 1/1 rib.
Intermediary lever to the left-hand side.
Racking lever to obtain needles and flow combs opposite.
Carriages at the right-hand side.

BACK				
FRONT				

NEEDLE BEDS	NEEDLES	POSITION
BACK		
FRONT		N° 1 Normal

1st and following rows :

Set row counter to 000 and unfasten the yarn from the stud.

CARRIAGES	KEY	STITCH	N.B.B.	N.S.B.	MOVEMENT
BACK					
FRONT					

BACK			RIB 1/1 + 3		
FRONT			RIB 1/1 + 3		KNIT

Casting-on :

Place mounting comb, wire and weights (do not forget the loop).

Casting-off :

Knit the last row in 1/1 rib with selection keys , see page 35.

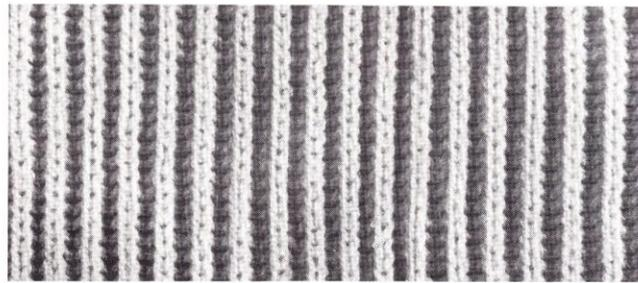

Casting-on: method 1

Casting-on method 2

Casting-on :

Beginning :

BACK	
FRONT	

See definition sheet for symbols.
Place mounting comb, wire and weights (do not forget the loop).

As for Method 1.

BACK					
FRONT					

Casting-on :

Place mounting comb, wire and weights (more weights than for 1/1 rib).

BACK		RIB 1/1			
FRONT		RIB 1/1			

BACK					
FRONT					

1st and following rows :

see above.

1st and following rows :

see above.

Single sided Fisherman rib

Beginning :

Space selector as for 1/1 rib.
Intermediary lever to the left-hand side.
Racking lever to obtain needles and flow combs opposite.
Carriages at the right-hand side.

BACK				
FRONT				

NEEDLES BED	NEEDLES	POSITION
BACK		
FRONT		N° 1 Normal

1st and following rows :

Set row counter to 000 and unfasten the yarn from the stud.

CARRIAGES	KEY	STITCH	N.B.B.	N.S.B.	MOVEMENT
BACK					
FRONT					

BACK			RIB 1/1 + 2		
FRONT			RIB 1/1 + 2		KNIT

Casting-on :

Place mounting comb, wire and weights (more weights than for 1/1 rib).

Casting-off :

Knit the last row in 1/1 rib with selection keys (see page 35).

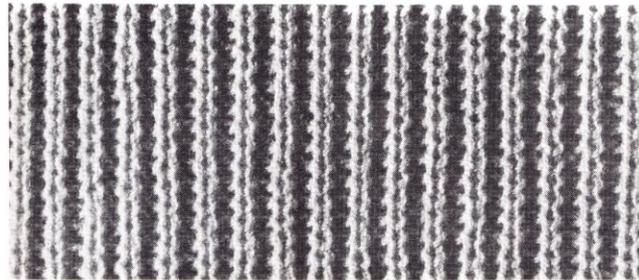

Casting-on method 1

Casting-on :

BACK	
FRONT	

See definition sheet for symbols.
Place mounting comb, wire and weights (do not forget the loop).

BACK					
FRONT					

BACK		RIB 1/1			
FRONT		RIB 1/1			

1st and following rows : see above.

Casting-on method 2

Beginning :

As for Method 1.

Casting-on :

Place mounting comb, wire and weights (do not forget the loop).

BACK					
FRONT					

1st and following rows : see above.

2/2 simple rib

Beginning :

Space selector as for 1/1 rib.
 Intermediary lever to the right-hand side.
 Racking lever one notch to the right-hand side, to obtain flow combs alternate.
 Carriages at the right-hand side.

NEEDLE BEDS	NEEDLES	POSITION
BACK	•• ••	
FRONT	• ••	N° 1 Normal

CARRIAGES	KEY	STITCH	N.B.B.	N.S.B.	MOVEMENT
BACK	△	⊙	••••		
FRONT	△	⊙	••••	••••	←

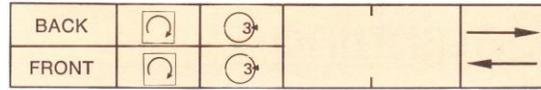

1st and following rows :

Intermediary lever to the left-hand side.
 Racking lever two notches to the left-hand side to obtain flow combs opposite.
 Set row counter to 000, and unfasten the yarn from the stud.

BACK	•• ••
FRONT	•• ••

BACK	△	RIB 1/1 + 2		
FRONT	△	RIB 1/1 + 2		KNIT

Casting-on :

Place mounting comb, wire and weights.

Casting-off :

see page 35.

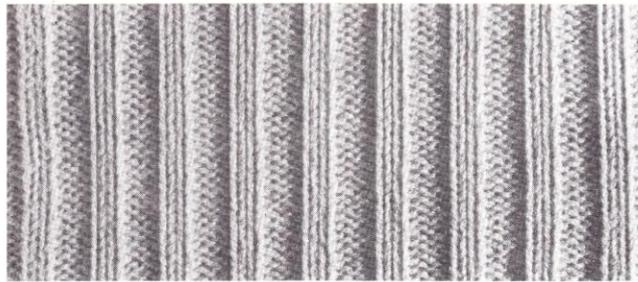

Casting-on method 1.

Casting-on :

BACK	•• ••
FRONT	• ••

See definition sheet for symbols.
 Place mounting comb, wire and weights (do not forget the loop).

BACK	△	⊙	••••		→
FRONT	△	⊙	••••	••••	

BACK		RIB 1/1	••••		←
FRONT		RIB 1/1	••••		

1st and following rows :

see above.

Casting-on method 2.

Beginning :

As for Method 1.

Casting-on :

Place mounting comb, wire and weights (do not forget the loop).

BACK	△	⊙	••••		→
FRONT	△	⊙	••••	••••	←

1st and following rows :

see above.

2/2 double sided Fisherman rib

Beginning :

Space selector as for 1/1 rib.
Intermediary lever to the right-hand side.
Racking lever one notch to the right-hand side to obtain flow combs alternate. Carriages at the right-hand side.

BACK				
FRONT				

NEEDLE BEDS	NEEDLES	POSITION
BACK	•• ••	
FRONT	• ••	N° 1 Normal

CARRIAGES	KEY	STITCH	N.B.B.	N.S.B.	MOVEMENT
BACK			••••		
FRONT			••••	••••	

1st and following rows :

Intermediary lever to the left-hand side.
Racking lever two notches to the left-hand side, to obtain flow combs opposite.
Set row counter to 000 and unfasten the yarn from the stud.

BACK	•• ••
FRONT	•• ••

BACK			RIB 1/1 + 2		
FRONT			RIB 1/1 + 2		KNIT

Casting-on :

Place mounting comb, wire and weights (more weights than for 1/1 rib).

Casting-off :

Knit the last row in 2/2 rib with selection keys (see page 35).

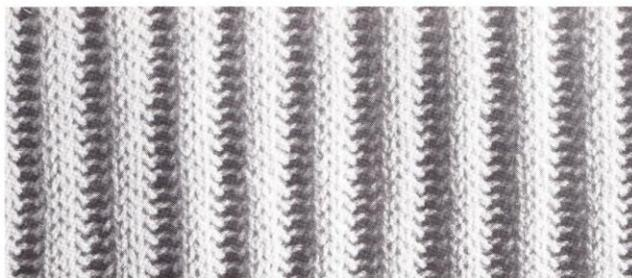

Casting-on method 1.

Casting-on :

BACK	•• ••
FRONT	• ••

See definition sheet for symbols.
Place mounting comb, wire and weights (do not forget the loop).

BACK			••••		
FRONT			••••	••••	

BACK		RIB 1/1	••••		
FRONT		RIB 1/1	••••		

1st and following rows :

see above.

Casting-on method 2.

Beginning :

As for Method 1.

Casting-on :

Place mounting comb, wire and weights (do not forget the loop).

BACK			••••		
FRONT			••••	••••	

1st and following rows :

see above.

2/2 industrial rib

Beginning :

Space selector as for 1/1 rib.
Intermediary lever to the right-hand side.
Racking lever one notch to the right-hand side, to obtain flow combs alternate.

BACK				
FRONT				

1st and following rows :

Intermediary lever to the right-hand side.
Racking lever one notch to the left-hand side.
Set row counter to 000 and unfasten the yarn from the stud.

NEEDLE BEDS	NEEDLES	POSITION
BACK		
FRONT		No 1 Normal

CARRIAGES	KEY	STITCH	N.B.B.	N.S.B.	MOVEMENT
BACK					
FRONT					

BACK	
FRONT	

BACK		RIB 1/1		
FRONT		RIB 1/1		KNIT

Casting-on :

Place mounting comb, wire and weights.

Casting-off :

see page 35.

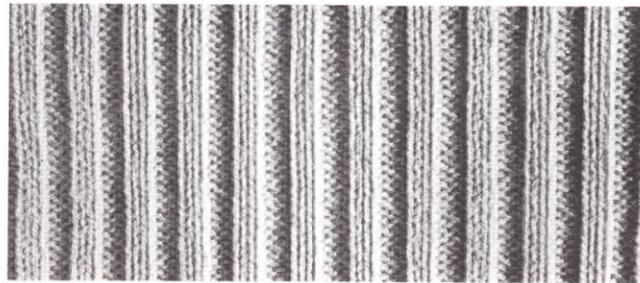

Casting-on method 1.

Casting-on :

BACK	
FRONT	

Place mounting comb, wire and weights (do not forget the loop).
See definition sheet for symbols.

BACK					
FRONT					

BACK		RIB 1/1 + 1			
FRONT		RIB 1/1 + 1			

1st and following rows :

see above.

Casting-on method 2.

Beginning :

As for Method 1.

Casting-on :

Place mounting comb, wire and weights (do not forget the loop).

BACK					
FRONT					

1st and following rows :

see above.



2/1 simple rib

Beginning :

Space selector as for 1/1 rib.
 Remove front carriage.
 Back carriage at the right-hand side.
 Take the mounting comb with wire with the red spot in the centre facing you. Position the comb teeth against the back flow combs to allow the free movement of the needles and tilt the comb backwards.

1st and following rows :

Space selector as for 1/1 rib.
 Replace the front carriage.
 Transfer the required stitches onto the front bed. Set row counter to 000, and unfasten the yarn from the stud.

NEEDLE BEDS	NEEDLES	POSITION
BACK		
FRONT	N° 1 Normal

BACK	
FRONT

CARRIAGES	KEY	STITCH	N.B.B.	N.S.B.	MOVEMENT
BACK	△	Stocking stitch	●●●		←

BACK	△	RIB 1/1 + 1		KNIT
FRONT	△	RIB 1/1 + 1		

Casting-on :

hang weights.

BACK		
FRONT	No 2 Upper



Casting-off :

see page 35.

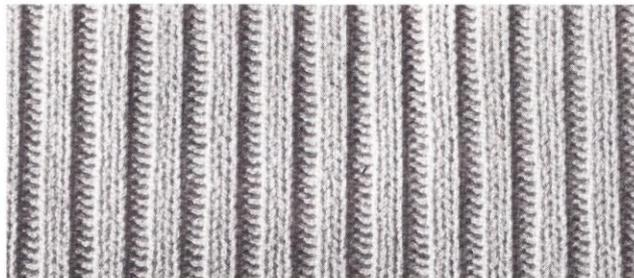

2/1 mock rib

Beginning :

Chain cast-on 2/3 needles.
Carriage at the left-hand side.
Position the comb teeth with wire against the back flow combs.

NEEDLE BEDS	NEEDLES	POSITION
BACK	· · · ·	▨

CARRIAGES	KEY	STITCH	N.B.B.	N.S.B.	MOVEMENT
BACK	△	Stocking stitch - 1 to 2	●●●●	▨	←

1st and following rows :

Set row counter to 000
After having knitted 4 to 5 rows, fix the knitting retainer.

BACK	· · · ·
------	------------

BACK	△	Stocking stitch			KNIT
------	---	-----------------	--	--	------

Casting-off : see page 35.

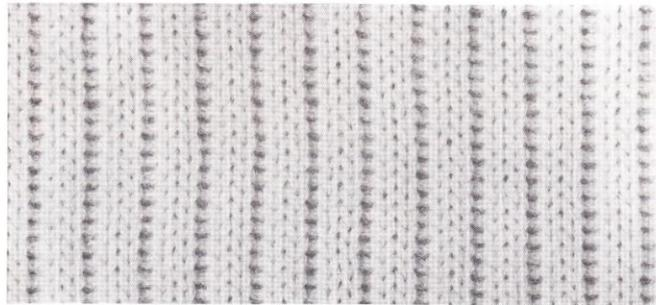

3/1 mock rib

Beginning :

Chain cast-on 3/4 needles.
Carriage at the left-hand side.
Position the comb teeth with wire against the back flow combs.

NEEDLE BEDS	NEEDLES	POSITION
BACK	· ·	▨

CARRIAGES	KEY	STITCH	N.B.B.	N.S.B.	MOVEMENT
BACK	△	Stocking stitch	●●●●	▨	←

1st and following rows : see above.

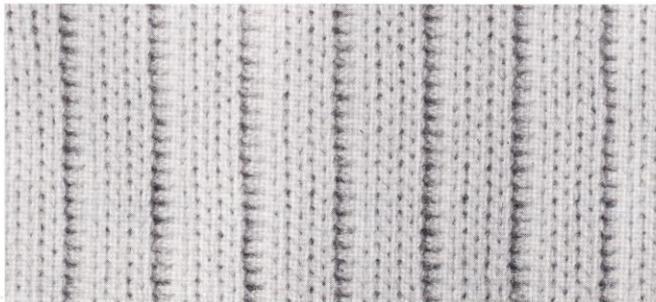

Increasing in 1/1 rib

Simple increase :

On carriage side and keeping the sequence of the rib, move an empty needle into working position 1.

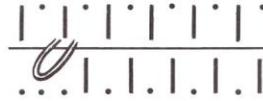
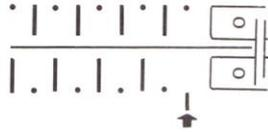

Simple transfer increase :

This can be done on both ends of the knitting, regardless of the carriage position.

- Using the double ended eyelet needle, take the last stitch and transfer it in sequence with the rib onto the opposite needle bed.
- Take the heel of the stitch before the last and hang it onto the recently cleared needle.



Double Italian increase :

This can be done on both ends of the knitting, regardless of the carriage position.

- On each needle bed at both sides, transfer sideways three or four stitches two needles outwards.
- Take the nearest heels of the stitches to fill the recently cleared needles.

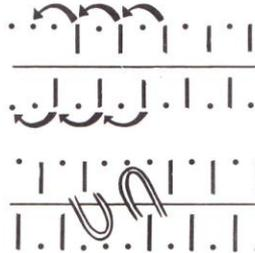

Decreasing in 1/1 rib

Simple decrease :

- Keeping the continuity of the rib and using the double ended eyelet needle, transfer the 1st stitch onto the 2nd.
- Move the needle which has two stitches into working position 2.
- Lower the empty needle into non-working position 0.
- Knit.

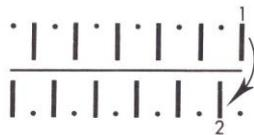

- Move the needles which have two stitches into working position 2.
- Lower the empty needles into non-working position 0.
- Knit.

Double Italian decrease (for V neck) :

Double decrease :

- Keeping the continuity of the rib and using the single eyelet tool, transfer the 1st stitch onto the 3rd and the 2nd stitch onto the 4th.

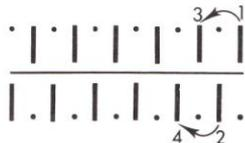

- Keeping the continuity of the rib and using the 3 eyelet tool, transfer:
 - the 5th, 3rd and 1st stitches onto the 7th, 5th and 3rd needles,
 - the 6th, 4th and 2nd stitches onto the 8th, 6th and 4th needles.
- Move the 7th and 8th needles, which have two stitches into working position 2.
- Lower the empty needles into non-working position 0.
- Knit.

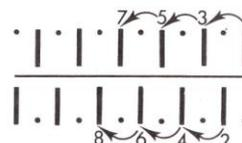

Increasing in single and double sided Fisherman rib

Simple increase :

- On the side of the carriages, next to the last stitch in working position move an empty needle into working position 2: two needles are now side by side.
- Knit.



Increasing several stitches :

- After having increased one stitch, knit a second row to bring the carriages back to the side of the increase.
- Move into working position 2 a second empty needle next to the last needles in working position and knit two rows (see second diagram).
- Transfer the centre stitch of the three end needles onto the opposite empty needle to keep the continuity of the rib.
- Lower the emptied needle into non-working position 0. Repeat above action as required.



Decreasing

Needles in holding position

In single and double sided Fisherman rib

On the side opposite to the carriages, move into holding position 3 an equal number of needles on each needle bed keeping the continuity of the rib.

Knit the required number of rows. To recall the needles from holding position 3 back to working position 1, using the single eyelet tool replace stitch and loop into the needle hook.

NOTE: This latter operation is necessary in single and double sided Fisherman rib to avoid a variation in the knitting at the point where the needles had been put into holding position.



The following decreasing may be done on either side.

Double sided Fisherman rib (Italian decrease).

Knit by hand the loop of the 3rd front bed needle in working position and replace the two stitches back onto next 4th needle in working position.

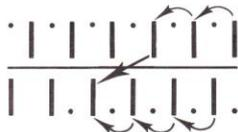

On this 4th needle also place the 3rd back bed stitch and move this 4th needle into working position 2. Transfer the first two stitches on each needle bed inwards. Lower to non-working position 0 the two empty needles and move the two needles holding two stitches into working position 2. Knit.

Single sided Fisherman rib

Place the 3rd back bed stitch onto the 2nd needle in working position and replace the two stitches back onto the 3rd needle.

Transfer the 1st stitch onto the 2nd newly emptied needle. Also place the 3rd front bed stitch onto the 2nd back bed needle and move the two front bed edge stitches inwards.

Do not forget to lower the empty needles into non-working position 0, and move the needles holding two stitches into working position 2.

The needles are again in sequence with the rib.



Other methods :

You may also proceed as for decreasing in stocking stitch (see pages 19-33) and in rib (see page 45).

Close rib (use fine yarn)

Beginning :

Space selector as for 1/1 rib.
Intermediary lever to the right-hand side.
Racking lever one notch to the right-hand side to obtain flow combs alternate.
Carriages at the right-hand side.

NEEDLE BEDS	NEEDLES	POSITION
BACK		
FRONT		N° 1 Normal

CARRIAGES	KEY	STITCH	N.B.B.	N.S.B.	MOVEMENT
BACK	△	⊙	●●●●		
FRONT	△	⊙	●●●●	●●	←

Casting-on :

Place mounting comb, wire and weights

BACK	⊙	⊙		→
FRONT	⊙	⊙		←

1st and following rows :

Set row counter to 000, and unfasten the yarn from the stud.

BACK	△	Stocking stitch - 2		
FRONT	△	Stocking stitch - 2		KNIT

Casting-off :

Knit one row with twice the stitch size set on each carriage.

Intermediary lever to the left-hand side.
Racking lever one notch to the right-hand side.
Transfer the front bed stitches onto the back bed needles.
Remove front carriage.

See page 35.

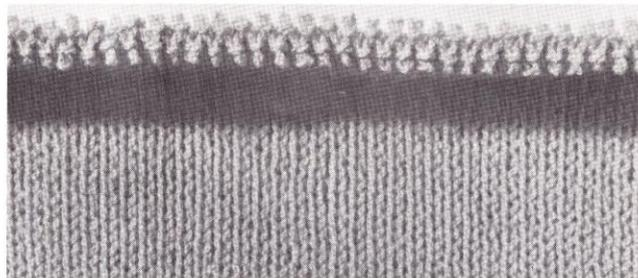

Circular stocking stitch

Beginning :

Space selector as for 1/1 rib.
 Intermediary lever to the right-hand side.
 Racking lever one notch to the left-hand side to obtain flow combs alternate.
 Carriages at the right-hand side.
 Use an auxiliary yarn.

BACK	
FRONT	

NEEDLE BEDS	NEEDLES	POSITION
BACK		
FRONT		N° 1 Normal

1st and following rows :

Intermediary lever to the left-hand side.
 Racking lever one notch to the right-hand side to obtain the flow combs opposite.

CARRIAGES	KEY	STITCH	N.B.B.	N.S.B.	MOVEMENT
BACK					
FRONT					

BACK	
FRONT	

BACK		Stocking stitch		
FRONT		Stocking stitch		KNIT

Casting-on :

Place mounting comb, wire and weights.
 Break the auxiliary yarn and fasten it to the left-hand stud.

Thread the main yarn but not the yarn guide.
 Place the needles on both needle beds into working position 1.

Starting from the left-hand side, loop the main yarn as follows  and knit by hand each needle.

Starting from the right-hand side proceed on the front bed in the same way as follows,  Thread main yarn in carriage yarn guide.

Set row counter to 000 and unfasten the main yarn from the stud.

Casting-off :

See page 35.

When the knitting is finished, remove the auxiliary yarn.

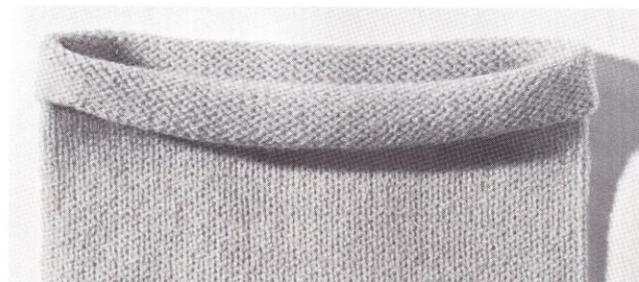



Semi-circular stocking stitch

This method allows to knit in stocking stitch garments which need more than 180 needles.

Eg. to knit in stocking stitch a garment of 220 stitches place 110 stitches on the back bed and 110 stitches on the front bed and knit in semi-circular.

1st row :

Intermediary lever to the left-hand side.
Racking lever one notch to the right-hand side to obtain flow combs opposite.

Beginning :

Space selector as for 1/1 rib.
Intermediary lever to the right-hand side.
Racking lever one notch to the left-hand side, to obtain flow combs alternate.
Use an auxiliary yarn.

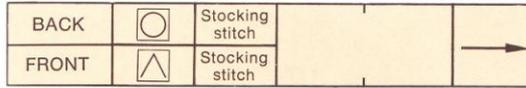

2ND ROW

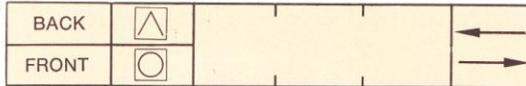

3RD ROW



NEEDLE BEDS	NEEDLES	POSITION
BACK		
FRONT		

CARRIAGES	KEY	STITCH	N.B.B.	N.S.B.	MOVEMENT
BACK					
FRONT					

Casting-on :

Place mounting comb, wire and weights.
Break the auxiliary yarn and fasten it to the left-hand stud.
Thread the main yarn but not the yarn guide.
Place the needles on both needle beds into working position 1.

Starting from the left-hand side, loop the main yarn as follows and knit by hand each needle.

Starting from the right-hand side proceed on the front bed in the same way as follows

Thread main yarn in carriage yarn guide.
Set row counter to 000 and unfasten the main yarn from the stud.

Following rows :

Knit repeating the instructions for the 2nd and 3rd row.

Casting-off :

see page 35.

When the knitting is finished, remove the auxiliary yarn.

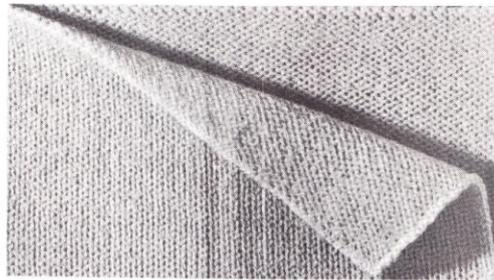

Thick yarn

Casting-on in stocking stitch :

Select twice the required number of needles and move every other needle into working position 1.
 Space selector on 6.
 Stitch size dial on size 10.
 Other settings as for stocking stitch (see page 17).



Casting-on in rib :

Select on each needle bed every fourth needle and move them into working position 1.
 Space selector on 6.
 Stitch size dial:
 1/1 rib: Size 6 on both carriages.
 Double sided Fisherman rib: Size 9 on both carriages.
 Single sided Fisherman rib: Size 8 on both carriages.
 Other settings as for rib (see page 16).

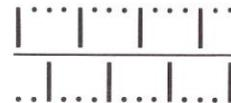

Pushing-down wheels (for rib only) :

Space selector on 6.
 Stitch size dial:
 1/1 rib: Size 9 on both carriages.
 Double sided Fisherman Rib: size 12 on both carriages.
 Single sided Fisherman Rib: size 11 on both carriages.
 Insert the two pushing down wheels into the spring clips located between the carriage brushes.
 ● Insert the right-hand wheel when the carriages are on the right-hand side.
 ● Insert the left-hand wheel when the carriages are on the left-hand side.

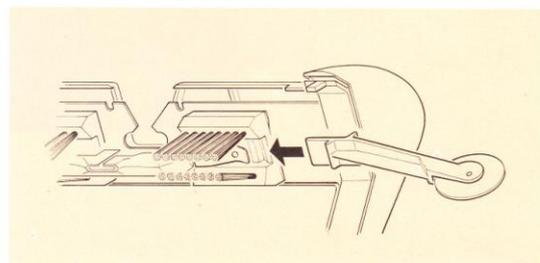

Buttonholes

Vertical buttonholes

- At the side opposite to the carriage, move into holding position 3 the needles between the edge and the position of the buttonhole.
 - Hang edge claws at the part to be knitted.
 - Knit an uneven number of rows corresponding to the size of the buttonhole.
 - Move into holding position 3 the needles which have just been in use.
 - Pass the carriage over these needles.
 - Bring into working position 2 the first group of needles in holding position 3.
 - Lower the front needle bed and form a loop pulling the yarn down.
 - Move the front needle bed into normal position and knit the same number of rows as for the first side.
 - Bring into working position 2 the needles in holding position (carriage on the opposite side) and continue knitting.
- The loop of the yarn serves to finish the buttonhole by hand.

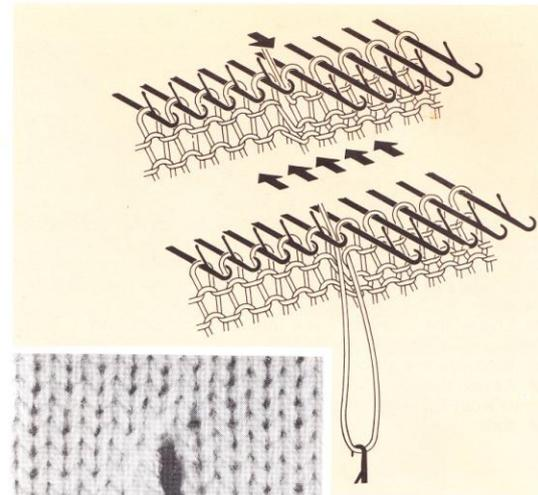

Round buttonholes

They are used for small buttons at ribbed welts or stocking stitch bands.

- With the single eyelet transfer tool, transfer one stitch on the next needle, or when knitting in rib, on the nearest needle of the opposite bed. Leave the empty needle in working position 1.

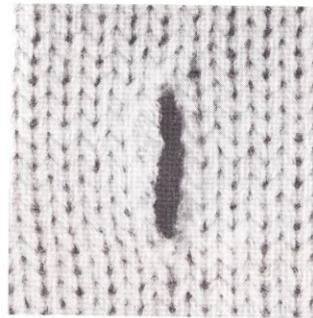

Horizontal buttonholes

- Bring into working position 2 the number of needles corresponding to the width of the buttonhole.
- Place a piece of contrasting yarn into these needles hooks.
- Lower the needles until the needle latches close.
- Pull down the needles individually by the heel back to working position 1.
- Continue to knit.
- When the garment is completed, withdraw the auxiliary yarn and using the back stitch method, complete the buttonhole.

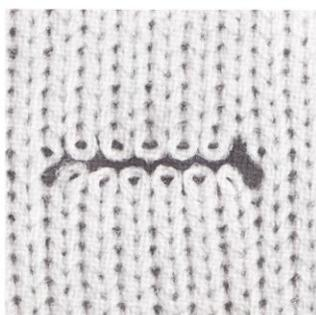
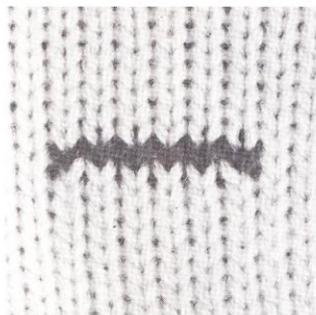
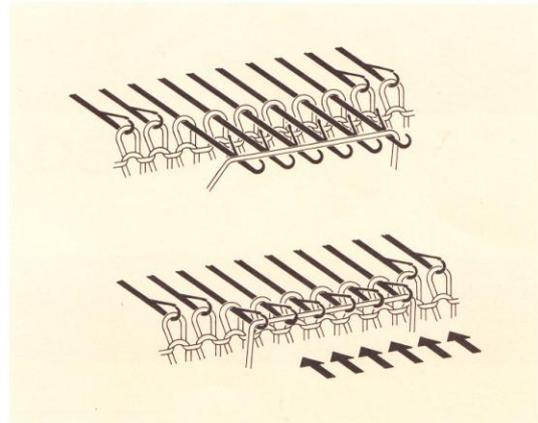

Hems

Simple hem

- Make an open casting-on.
- Knit twice the depth of the hem.
- Move the needles into holding position 3. Remove the weights, lower the front needle bed.
- Using the hook of the latch needle tool, take the stitches from the comb and place them onto the back bed needles.
- Lower the needles back into working position 2, place the front bed into upper position and rehang the weights.
- Increase the stitch size by 3 sizes and knit one row.
- Reset the row counter deducting half the number of rows from the hem and reset the stitch size.
- Knit.

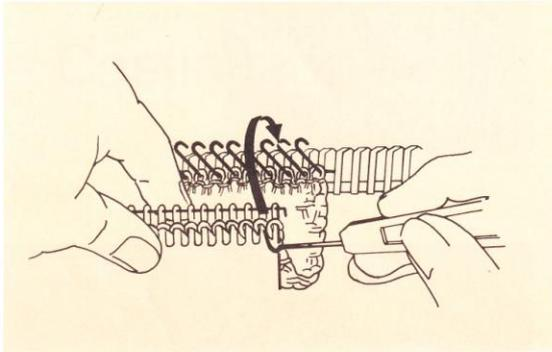

Picot edge hem

- Make an open casting-on using an uneven number of needles.
- Knit the required number of rows for the hem.
- Using the single eyelet tool, transfer each uneven stitch except the edge stitches (see diagram) onto the next needle. A row of holes is thus formed.



- Move the needles holding two stitches into working position 2 and leave the empty needles in working position 1. They will knit on the next row.
- Knit the second half of the hem plus one row.
- Proceed as for the simple hem.
- When the hem is completed, the row of holes will form the picot edge.

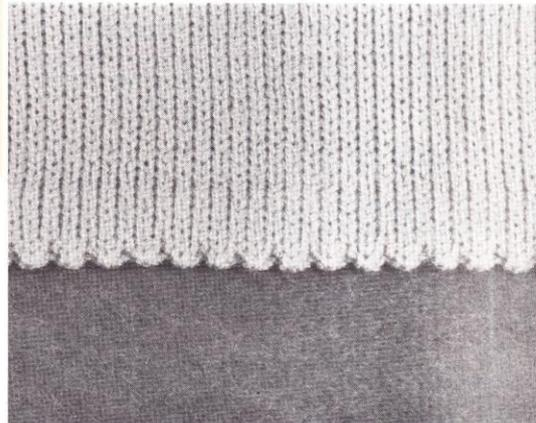

Circular hem

- Move the needles on both needle beds into working position 1.
- Intermediary lever to the right-hand side.
- Racking lever one notch to the left-hand side to obtain flow combs alternate.
- Key  on both carriages.
- Stitch size 1.
- Knit one row.
- Place the mounting comb, wire and weights.
- Reset the flow combs opposite.
- Key  on both carriages.

- Stocking stitch size.
- Knit the required number of rows for the hem.

CAUTION: one circular row = two rows on the row counter.

- To close the circular hem, transfer the front bed stitches onto the back bed needles.
- Remove front carriage.
- Key  on back carriage.
- Knit one row.
- Place the front bed into upper position.
- Continue to knit.

Hem-fold

- Carriage at the left-hand side ←, unthread the carriage yarn guide and hold the yarn with your right hand.
- Move the first left-hand needle into holding position 3.
- Loop the yarn around this needle anti-clockwise, once behind the latch and once in front of the latch, as illustrated.
- Lower the needle back into working position 1.
- Repeat above action across each needle. The stitches must be knitted loosely.
- Cancel selection keys  and bring the carriage back to the right-hand side.
- To commence knitting, depress selection key .

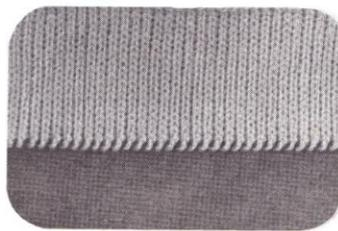
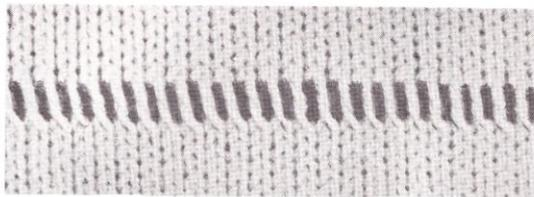
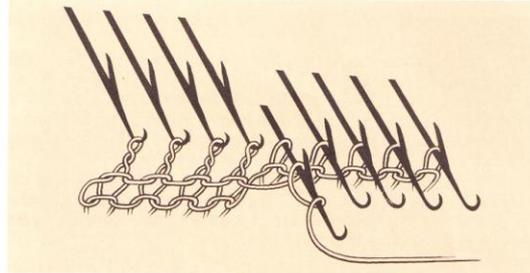

Neckband

- Cast-on in 1/1 rib on the required number of stitches.
- Knit 8 rows in 1/1 rib, transfer to stocking stitch onto the back bed, set stocking stitch size and knit one row.
- Sew the neckband stitch by stitch onto the garment placing the stocking stitch row uppermost around the neckline.

NOTE FOR SB.: The neckband may be knitted in 1/1 Mock Rib. On the row before the last transfer the heel of the stitch onto the next empty needle.

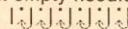

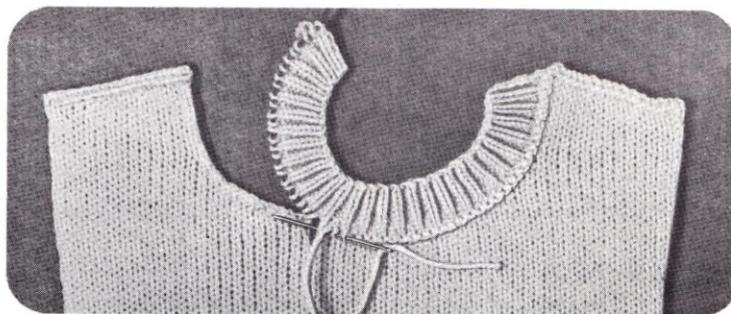
Knit one row in stocking stitch on all needles.



Pockets

When preparing the garment, the place of the pocket has to be determined:

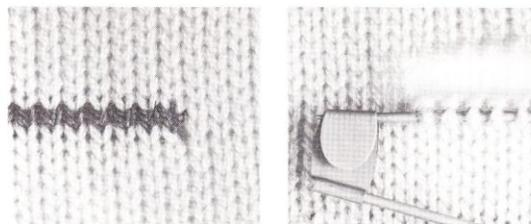
- Arriving at the row where the pocket is foreseen, move into working position 2 the required number of needles for the width of the pocket.
- As for horizontal buttonhole, knit these stitches with a contrasting yarn (see picture).
- When the garment is finished, remove the contrasting yarn from the opening of the pocket and take the lower stitches of the opening onto a stitch-holder, a hand knitting needle or onto an auxiliary yarn (see picture).
- The upper stitches of the opening will be placed on the back bed needles to knit the pocket piece (the transfer is easier if the stitches are taken on an auxiliary yarn before transferring them).



Single pocket piece

- With the right side of the knitting (A) facing you, fold the knitting towards the back at the level of the pocket and using the single eyelet tool, replace the upper stitches of the opening onto the back bed needles.
- Hang the edge claws.
- Knit the required number of rows corresponding to the depth of the pocket.
- Chain cast-off these stitches. The single pocket piece is then sewn with slip stitches on the back of the garment.
- With the right side of the knitting facing the machine, replace the stitches from the stitch-holder onto the back bed needles.
- Increase one stitch at both sides taking the heel of the next stitch.
- Knit a few rows in stocking stitch (6 to 8).
- Chain cast-off.
- Slip stitch the welt onto the front of the garment.

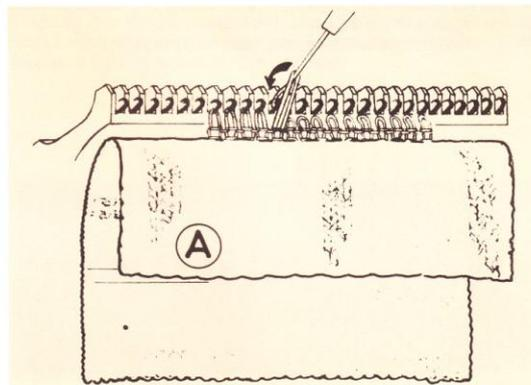

Double pocket piece

This pocket is only used with fine yarn.

- Proceed as for a single pocket piece and knit in stocking stitch twice the required number of rows for the depth of the pocket piece without casting off the stitches.
- Transfer the stitches from the stitch-holder onto the front bed needles, opposite to the back needles which are in working position.
- Flow combs alternate.
- Set stitch size as for Close Rib on both carriages and depress key. 
- Knit a few rows in Close Rib.
- Cast-off.
- Sew the sides of the pocket piece.
- Slip stitch the welt onto the garment.

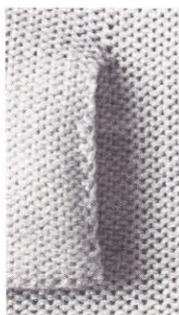

Pocket with flap

- With the wrong side of the knitting facing you, fold the knitting towards the front at the level of the pocket and using the single eyelet tool, replace the lower stitches of the opening onto back bed needles.
- Hang edge claws.
- Knit a double pocket piece.
- Place also the upper stitches of the opening from the stitch-holder onto the back bed needles.
- Chain cast-off.
- To obtain the flap rehang the lower part of the chain casting off onto the back bed needles and increase one stitch at both sides taking the heel of the next stitch.
- Set these stitches according to the required type of knitting for the welt. Knit a few rows and cast-off.
- Set the pocket piece.
- Fix the upper part of the welt.



Socks

- Cast on 60 needles in 2/2 Industrial Rib, i.e. numbers 22 and 23 on each side of the zero on the graduated scale. It is advisable to leave a long endpiece of yarn that will be used for sewing up the ribbing.
- Position front bed for correct needle setting.
- Set stitch size as required.
- Set row counter to 000.
- Knit 51 rows in 2/2 Industrial Rib (carriages are again at the right-hand side).
- Using the double ended eyelet needle, transfer the stitches of the front bed onto the empty needles of the back bed (both stitches of front bed are transferred onto the same needle, between two needles of back bed). After transferring, there are 45 stitches on the back bed.



- Set flow combs opposite and the front needle bed in upper position.
- Set stitch size as for stocking stitch.
- Knit one row.
- Opposite to the carriage, (on the righthand side) move 1/4 of the needles into holding position 3, in this case 11 needles.
- Pass the carriage to right-hand side.
- Opposite to the carriage (on the lefthand side), move 1/4 of the needles + 1 into holding position 3, in this case 12 needles.
- Set the front needle bed into normal position and leave only one weight in the middle of the comb.
- Place in the centre of the front bed, opposite to the needles in working position of the back bed, 22 needles into working position 1.
- Open the latches of these needles.
- Lower the front bed into intermediary position.
- Using the 20 eyelet transfer tool, (remove the security cover), take the stitches of the first group of needles in holding position 3, first eyelet of the transfer tool opposite to the first needle in the centre.
- Replace the security cover.
- Let the transfer tool drop between the needle beds.
- Take it by its body turning it towards the centre and bring it up again.
- Place it opposite to the empty needles prepared on the front bed.
- Remove the security cover.
- Introduce the eyelets of the transfer tool into the needle hooks.
- Tilt the transfer tool to allow the stitches to slide into the needle hooks.
- Pull slightly the knitting with your free hand during this operation.
- Repeat this procedure on the other side (the needle in the centre of the front bed has 2 stitches).
- After these different operations, there are, in this case, 22 stitches on each needle bed, needles set for circular knitting, i.e. opposite.
- Front bed normal position.
- Re-hang the required number of weights.

IMPORTANT: Do not forget to lower empty needles into non working position 0.

- Key  on both carriages.
- Stocking stitch size.
- Knit 10 rows in circular i.e. 20 rows on the row counter.



The heel :

The heel is only knitted on the front bed.

- Stitch size 1 on back carriage.
- Keys  cancelled on back carriage.
- Stitch size on front carriage as for stocking stitch less on size to reinforce the heel.
- Key  on front carriage.
- AT CARRIAGE SIDE, on front bed, move the first right-hand needle into holding position 3.
- Move carriages to the left-hand side.
- Move also the first left-hand needle into holding position 3.
- Move carriages to the right-hand side.
- Repeat these operations until 1/3 of the needles are in holding position 3 on both sides (i.e. 7 needles).

CAUTION: Do not forget to hang edge claws into the heel to allow the normal pulling down of the stitches.

- To do this, insert your hand in the circular knitting.
- Hang the edge weights and claws towards the front.
- Do not forget to move up gradually and towards the centre the claws when knitting.
- OPPOSITE TO THE CARRIAGE, lower to working position 2 the left-hand needle in the centre of the heel (the last needle which was moved into holding position 3 is the first to be lowered).
- Move the carriages across.
- Lower to working position 2 the right-hand needle in the centre of the heel.
- Continue this procedure until both edge needles remain in working position 3 (do not forget to move gradually the edge claws).
- These two needles are lowered simultaneously into working position 2, placing the yarn under the right-hand needle.
- Move carriages to the left-hand side.

The foot :

- Continue to knit in circular.
- Keys .
- Set the same stitch size as for circular knitting previously knitted on both carriages.
- Knit 25 rows, i.e. 50 rows on the row counter.
- After a few rows in circular, remove the edge claws.

The toe :

- Using double eyelet tool, transfer the 1st and 2nd stitches onto the 2nd and 3rd needles at each end of both beds.
- Knit three circular rows (5 rows on the row counter) and repeat decreasing.
- Knit two circular rows (4 rows on the row counter).
- Repeat decreasing.
- Continue shaping knitting always one circular row (2 rows on the row counter) until only 4 stitches remain on each bed.
- Reduce progressively the number of the weights.
- Break the yarn and thread it in the double ended eyelet needle.
- Take the remaining stitches clockwise one after the other onto the needle, pulling the yarn through each stitch.
- Close the stitches pulling on the end of the yarn.
- Sew up ribbing with invisible seam (see page 24).

Chart of sizes

The measurements may change according to the stitch size and to the thickness of the yarn.

Metric Sizes	15	18	21	24	27	30	33	36	39	42	45
British Sizes	1	2 ¹ / ₂	4 ¹ / ₂	7	9 ¹ / ₂	11 ¹ / ₂	1	3 ¹ / ₂	5 ¹ / ₂	8	10 ¹ / ₂
Figure on each side of 0 on the graduated scale for casting-on in 2/2 Industrial Rib.	16	20	24	28	28	32	32	36	36	38	38
Number of rows in 2/2 Industrial Rib for the leg	35	45	54	60	80	90	100	90	100	110	120
Decreasing to be made for the ankle on the first circular row at equal distance, on each bed	2	3	3	3	3	3	3	3	4	4	3
Number of circular rows for the ankle (x 2 on the row counter)	5	5	5	8	8	8	12	12	16	16	16
Number of circular rows for the foot (x 2 on the row counter)	25	30	33	36	39	42	45	48	52	56	60
Decreasing to be made every 2 circular rows (x 2 on the row counter)	3	4	4	5	5	6	6	6	6	7	7
Number of remaining stitches to be taken on each end	3	3	3	3	3	3	5	5	5	5	5
Length of the foot in cm according to the size	10	12	15	16	18	20	21	22	24	26	27

How to knit

Fair Isle

Using the second yarn guide

The second yarn guide allows to create a wide variety of decorative two-coloured patterns in one passage of the carriage.

This accessory is composed of:

- The body «A».
- The locking keys «B» to attach it to the carriage.
- The needle raisers «C» which can be unlocked and turned.
- Two slots «E» and «D» allow the passage of the two yarns.
- The slot «D» belongs to the main yarn.
- The slot «E» belongs to the second yarn.

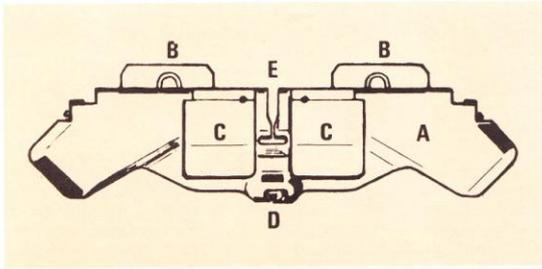

Attach the second yarn guide:

- Lower the front bed.
- Position the two metal fingers «F» into the space at each side of the brushes.
- Push into position.
- Lock it by sliding the two locking keys «B» towards the outside.
- Thread the left-hand side of the tension unit and the second yarn guide (slot «E») with the second yarn.
- The yarn guide with slot «D» threads itself automatically if commencing Fair Isle knitting at the right-hand side. If beginning at the left-hand side, you must thread slot «D» in addition to the carriage yarn guide before attaching the second yarn guide to the machine.
- When re-threading the main yarn, you must also thread slot «D» regardless of the position of the carriage.

On the back bed only :

- Thread the right-hand side of the tension unit and the main yarn guide with the main yarn.
- Cast-on to your choice.
- Depress simultaneously key  and jacquard key .
- Needle return buttons in upper position.
- Stocking stitch size.

To knit two yarns simultaneously, set the front bed into normal position and the space selector on 3 or 4 according to the thickness of the yarn.

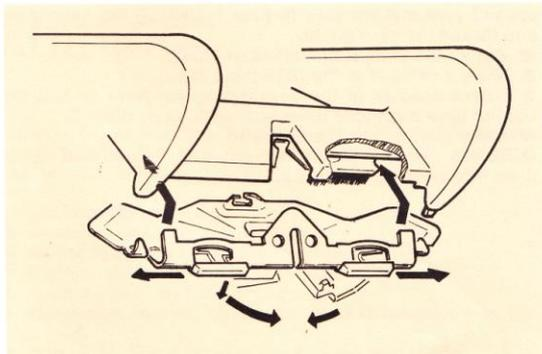

Knitting :

- After casting-on, move the needles which have to knit the second yarn into working position 2 without making the stitches slide behind the latches.
- The needles which have to knit the main yarn remain in working position 1.
- Knit 1 row.
- Select the needles of the second row and move them into working position 2 without making the stitches slide behind the latches.
- Knit one row and continue until you obtain the required pattern.
- Use edge claws if necessary and rehang them every 5 to 10 rows.
- When the pattern is finished, remove the second yarn guide by sliding the two locking keys «B» towards the centre.

Some important principles :

To unlock a jammed carriage explained in «What to do if» you must first disengage the needle raisers «C» which cover the needles (see page 58).

- Move the needle raisers «C» as illustrated.
 - Proceed normally to the unlocking of the carriage.
- Never pass the carriage with the second yarn guide across empty needle.
Remove always the second yarn guide when the knitting is finished.

Patterns with long floats on the edge (eg. : checkered pattern with more than 4 stitches) :

To give a better hold to the knitting, it is advisable to move after each row the end needle, opposite to the carriage, into working position 2.

When using the second yarn guide never bring needles into holding position 3, they would be automatically recalled by the Jacquard key .

To make a neckline, you may:

- Transfer the stitches which do not have to knit onto a stitch-holder or onto the front bed.
- Knit two rows by hand, with an auxiliary yarn, the stitches which should be moved into holding position 3.
- Remove these stitches from the needles.
- Lower the empty needles into non-working position 0.
- Knit the first side of the neckline.
- Cast-off the stitches.
- When required, replaced the stitches of the second side of the neckline onto the initial needles to keep the continuity of the pattern.
- Remove the auxiliary yarn.
- Knit the second side of the neckline.

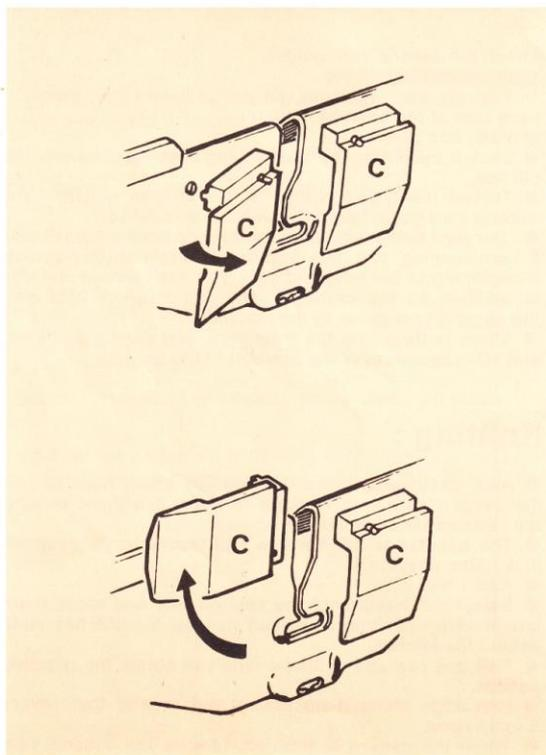

CAUTION: The purl side of the Fair Isle will of course show floats. It is therefore advisable to choose patterns accordingly avoiding the long floats.

If you have a D.B. machine, it is advisable to knit Norwegian Jacquard or Fancy Jacquard.

NOTE FOR S.B.:

- After casting-on knit 4 to 5 rows pulling slightly on the mounting comb.
- Attach the knitting retainer. A better result is obtained when using weights.

Norwegian Jacquard :



Alternatively to the Fair Isle explained on page 57 which can also be knitted on a S.B. machine, we explain hereafter the true Norwegian Jacquard. Both yarns are knitted on every alternate stitch on the front bed every 2 rows which avoids the floats, thus showing an even surface on both sides.

- Thread the right-hand side of the tension unit and the machine with the main yarn, carriages at the right side.
- Bring an even number of needles in working position 1 on both beds.
- Cast-on as for Close rib (see page 47).
- Knit a few rows, bring carriages to the right-hand side.
- Insert the Jacquard claw on the left-hand side, of the back carriage, signs and boss upwards into the fixing spring under the left-hand brush of the carriage. Insertion is made easier by unlocking and lifting the carriage. Do not forget to lock it again.
- Keys cancelled  on both carriages.
- Needle return buttons in neutral position on both carriages.
- Needle selection button  on front carriage.
- Stitch size as for 1/1 Rib.
- On the back bed select needles which have to knit the main yarn and move them into working position 2 without making the stitches slide behind the latches.
- Move carriages to the left-hand side.
- On the back bed select needles which have to knit the second yarn and move them into working position 2, without making the stitches slide behind the latches.
- Unthread the yarn guide making sure to pass the yarn under the brushes thereby avoiding the yarn catching.
- Place the yarn in the back notch of the Jacquard claw opposite to the symbol  representing the main yarn threaded in the right-hand side of the tension unit.
- Push the Jacquard claw towards the front.
- Thread the left-hand side of the tension unit with the second yarn making sure to pass it UNDER the main yarn and thread the yarn guide.
- Fasten the yarn at the left-hand clamp.
- Move carriages to the right-hand side.
- Select needles of the next row which have to knit the second yarn and move them into working position 2.
- Move carriages to the left-hand side.
- Select needles which did not knit before and move them into working position 2.

- Unthread the yarn guide making sure that the yarn passes under the brushes thereby avoiding the yarn catching.
- Place the yarn in the front notch of the Jacquard claw opposite to the symbol \circ representing the second yarn threaded in the left-hand side of the tension unit.
- Push Jacquard claw towards the back.
- Unhook the yarn which did not knit before, pull it towards the front and present it in the opening of the carriage above the yarn guide (the yarn passes in front of the right brush).

hand, it will thread into the yarn guide automatically (see drawing).

- Move carriages to the right-hand side.
- Select needles of the next row which have to knit the main yarn.
- Move carriages to the left-hand side.
- Select needles which did not knit before.
- Unthread the yarn guide making sure that the yarn passes under the brushes and under the second yarn placed in the Jacquard claw.
- Place the yarn into the back notch of the Jacquard claw opposite to symbol \circ .
- Push Jacquard claw towards the front.
- Unhook the second yarn, pull it towards the front, etc. (see above).
- Move carriages to the right-hand side.
- Select needles of the next row which have to knit the second yarn.
- Move carriages to left-hand side *.
- Repeat from * to *.

CAUTION: Change row when carriages are on right-hand side and change the yarn when the carriages are on left-hand side.

IMPORTANT: One complete row of knitting = 2 rows registered on the row counter.

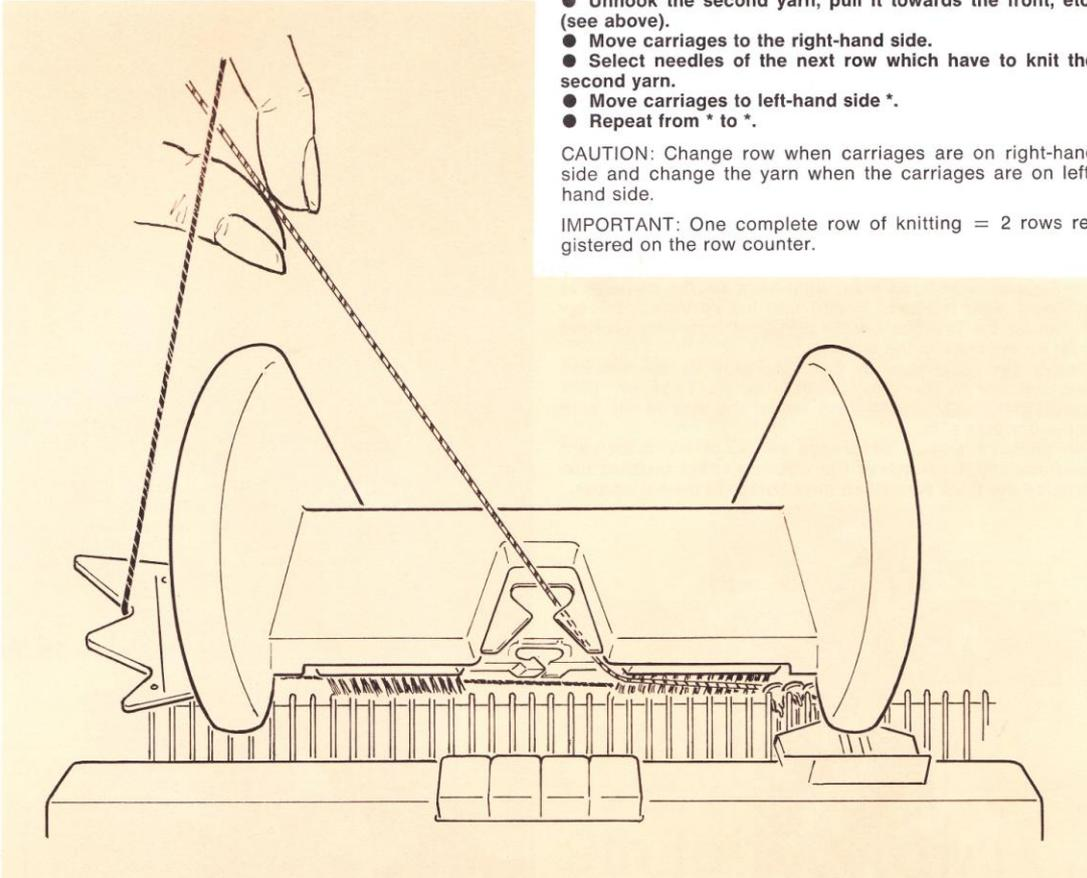

Fancy Jacquard knitting

Another easier method of Jacquard knitting can be obtained by setting the back carriage as for Fair Isle using the second yarn guide.

But, on the front carriage:

- Jacquard key  depressed.
- All the other keys cancelled  .
- Needle return buttons in neutral position.
- Needle selection buttons  .
- Make sure an even number of needles is cast-on on the front bed.
- Knit as for Fair Isle using the second yarn guide.

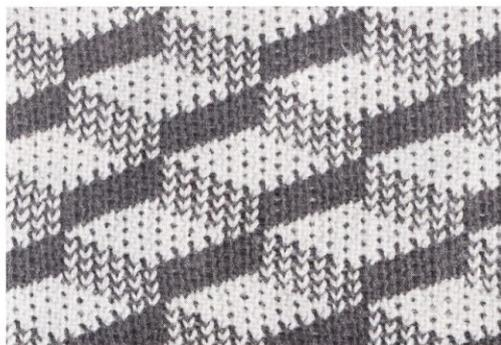

Weaving effect

Accessories :

A weaving effect is obtained by using a generally thicker differently coloured second yarn and by inserting weaving effect brushes into the same springs foreseen for the pushing-down wheels.

The weaving effect brushes are composed of:

- a wheel-brush which function is to push the thick yarn between the flow combs.
- a guide with a notch which function is to present the thick yarn to obtain the weaving effect.

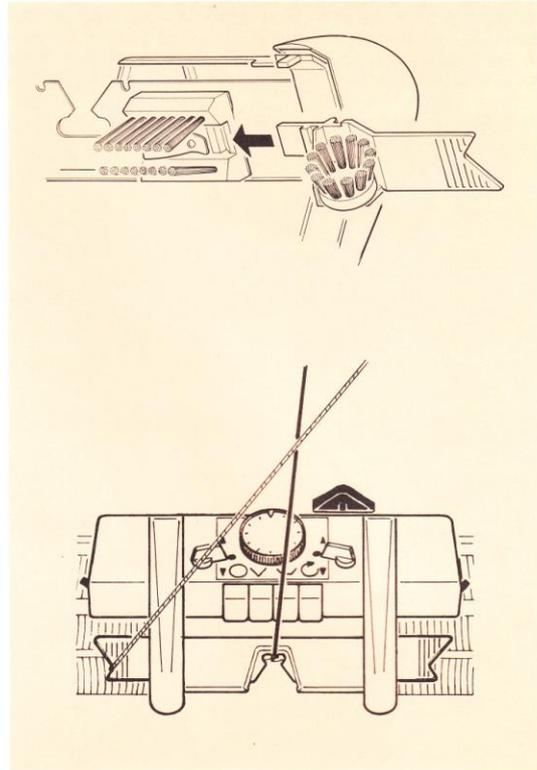

Knitting :

Cast-on in stocking stitch with the main yarn (left side). Knit a few rows, then insert the weaving effect brushes (carriage at right-hand side: right-hand brush; carriage at left-hand side: left-hand brush) into the spring-clips located under the brushes on the back carriage (the brushes must be opposite to the knitter).

Thread the thick yarn in the right side of the tension unit, but not in the carriage yarn guide. Pass the yarn between the needle beds and fasten the end to the stud at the carriage side.

The thick yarn must be always ahead of the main yarn consequently the notch of the weaving effect brushes has to guide the thick yarn when the carriage is moved across.

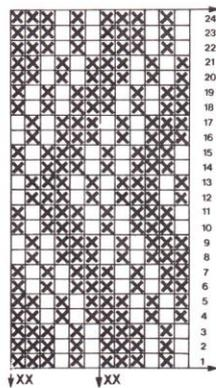

⊗ = needle to be moved into working position 2. Repeat from xx to xx.



1st method

BACK CARRIAGE:

Key: 

Needle return buttons: neutral.

Stitch size: stocking stitch.

Space selector: 3.

FRONT BED: normal position.

Select the required needles for the pattern and move them into working position 2.

2nd method

BACK CARRIAGE:

Key: 

Needle return buttons: lower position.

Stitch size: stocking stitch.

Space selector: 6.

FRONT BED: upper position.

Select the required needles for the pattern and move them into holding position 3.

Knit one row.

After each row place the thick yarn in front of the brush-guide on the opposite side of the carriage. Select in the same way and according to the pattern the needles for the next row — in working position 2.

Knit one row.

Repeat this operation until the pattern is finished. After this, remove the weaving effect brushes.

NOTE: For easier and quicker operation it is advisable to bring the needles between working position 1 and position 2 without making the stitches slide behind the latches.

NOTE FOR S.B.: After casting-on knit 4 to 5 rows pulling slightly on the mounting comb. Before attaching the knitting retainer fit both central wheels, raised side in front of you, into the corresponding slots and push backwards.

Knit one row.

After each row place the thick yarn in front of the brush-guide on the opposite side of the carriage. Select in the same way and according to the pattern the needles for the next row — in holding position 3.

Knit one row.

Repeat this operation until the pattern is finished. After this remove the weaving effect brushes.

NOTE: Remove the thick yarn slightly before the end of the row.

NOTE FOR S.B.: After casting-on knit 4 to 5 rows pulling slightly on the mounting comb. Before attaching the knitting retainer, fit both central wheels, raised side in front of you, into the corresponding slots and push backwards.

Racking pattern

An unlimited number of knitting possibilities for racking patterns can be obtained according to the needle setting, the chosen selection key and the number of rows required for the racking. This chart shows therefore only ONE of the many racking patterns possible.

Beginning :

Space selector as for 1/1 Rib.
Intermediary lever to the right-hand side.
Racking lever: 3 notches towards the right-hand side (notch number 7 on the racking scale).
Back and front carriages at the right-hand side.

NEEDLE BEDS	NEEDLES	POSITION
BACK		N° 1 Normal
FRONT		

CARRIAGES	KEYS	STITCH	N.B.B.	S.B.B.	MOVEMENT
BACK					
FRONT					

Casting-on :

Place mounting comb, wire and weights.

BACK					
FRONT					

1st row :

- a) Intermediary lever to the left-hand side — racking lever one notch to the right-hand side. Transfer the front bed stitches which are not required for the pattern onto the back bed needles.
- b) Intermediary lever to the right-hand side — racking lever one notch to the right-hand side. Set row counter to 000 and unfasten the yarn from the stud.

BACK	
FRONT

BACK		Stocking stitch		
FRONT		RIB 1/1		

2nd to 8th row :

Before each row, move the racking lever one notch to the left-hand side.

9th to 15th row :

Before each row, move the racking lever one notch to the right-hand side.

Following rows :

Continue repeating the operations given from the 2nd row.

Casting-off : see page 35.

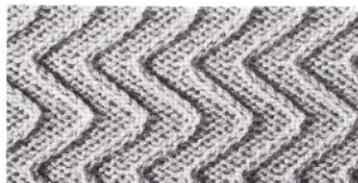

Fancy pattern



Casting-on as for close rib :

See page 47
Flow combs alternate.

Needle setting :

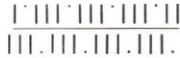

Selection keys :

Back carriage: 
Front carriage: 

Stitch size :

Back carriage: as for double sided Fisherman rib.
Front carriage: as for double sided Fisherman rib.

Procedure :

* Racking lever: 1 notch to the right-hand side, knit 4 rows.
Racking lever: 1 notch to the left-hand side, knit 4 rows *.
Repeat from * to *.

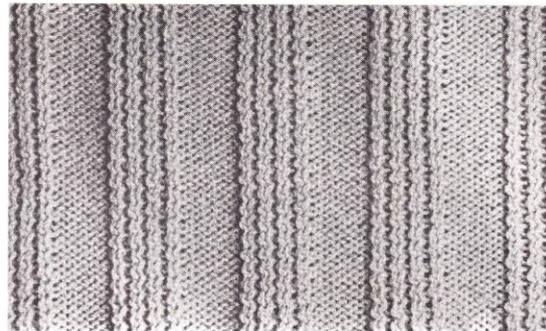

Casting-on as for close rib :

See page 47.
Flow combs alternate.

Needle setting :

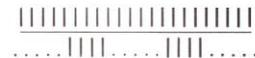

Selection keys :

Back carriage: 
Front carriage: 

Stitch size :

Back carriage: as for stocking stitch.
Front carriage: as for stocking stitch.

Procedure :

* Racking lever: 1 notch to the right-hand side, knit 1 row.
Racking lever: 1 notch to the left-hand side, knit 1 row *.
Repeat from * to *.

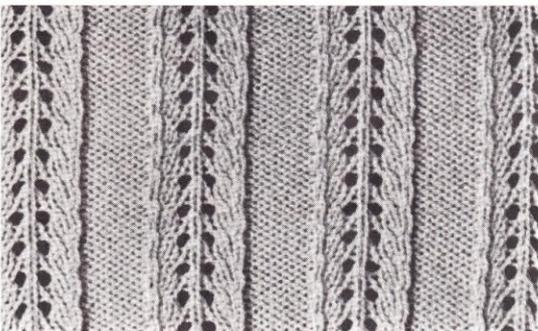

Closed casting-on in stocking stitch or in 1/1 rib :

See page 31 and 36.

Needle setting :

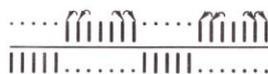

Selection keys :

Back carriage: 
Front carriage: 

Stitch size :

Back carriage: as for stocking stitch.
Front carriage: as for stocking stitch less one size.

Procedure :

The front bed stitches remain always on the same needles. Only certain back bed stitches have to be moved as follows:

* At each end of the groups of 7 stitches and using the double eyelet tool, transfer the 2nd and 3rd stitches onto the 1st and 2nd needles.

Move into working position 2 the needles carrying two stitches and into working position 1 the just emptied needles.

Knit 4 rows *.
Repeat from * to *.



Casting-on as for close rib :

Use fine yarn. Flow combs alternate.

Needle setting :



Selection keys :

Back carriage: 
 Front carriage: 

Stitch size :

Back carriage: as for stocking stitch.
 Front carriage: as for stocking stitch.

Procedure :

The back bed stitches remain always on the same needles. Only certain front bed stitches are used to make the pattern as follows:

* Knit 6 rows.

Let the three central stitches of the five stitch groups on front bed drop (place these three needles into non-working position 0) and move into working position 2 the three stitch groups previously moved into non-working position 0*.

Repeat from * to*.

NOTE: When the knitting is finished, it is necessary to pull into shape as the dropped stitches are not always undone.



Closed casting-on in stocking stitch :

See page 31.

Needle setting :



Selection keys :

Back carriage: 
 Front carriage: 

Stitch size :

Back carriage: as for stocking stitch + 2 sizes.
 Front carriage: as for stocking stitch + 2 sizes.
 Space selector: as for stocking stitch less one position.

Procedure :

* Knit 10 rows.

On the back bed for the groups of 4 stitches, cross the 2 right-hand stitches with the 2 left-hand stitches passing the 2 left-hand stitches in front of the 2 right-hand stitches (after such operation, always move these groups of 4 stitches into working position 2)*.

Repeat from * to*.

Selection keys :

Back carriage: 
 Front carriage: 

Stitch size :

Back carriage: as for stocking stitch.
 Front carriage: as for stocking stitch + 2 sizes.

Procedure :

* Knit 4 rows.

Take the front bed stitches and move them two needles towards the right-hand side, then transfer them onto the opposite back bed needles, as illustrated.

Move the back bed needles carrying two stitches into working position 2. Move the front bed needle at the right-hand side of each just emptied needle into working position 1*.

Repeat from * to*.



Casting-on as for close rib :

Flow combs alternate.

Needle setting :

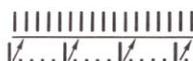

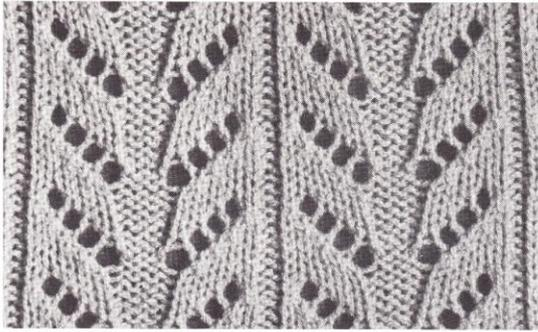

Closed casting-on in stocking stitch or in 1/1 rib :

See page 31 and 36.

Needle setting :

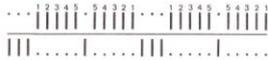

Zig-zag pattern

To succeed the casting-on of a fancy pattern regardless of the final needle setting, you must respect one thing as a guide:
THE CASTING-ON MUST ALLOW A YARN DISTRIBUTION IN ZIG-ZAG.

To cast-on, set the needles to ensure an even distribution of the yarn on both beds.
Example: to knit the following pattern:

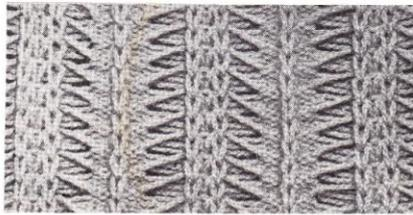

The casting-on has to be done as follows to obtain the necessary zig-zag formation:



Selection keys :

Back carriage: 
Front carriage: 

Stitch size :

Back carriage: as for stocking stitch.
Front carriage: as for stocking stitch.

Procedure :

The front bed stitches remain always on the same needles. Only the back bed stitches are used to make the fancy pattern. Move the needles carrying two stitches into working position 2 and the emptied needles into working position 1.

* Transfer stitches n° 1 onto needles n° 2. Knit two rows.
Transfer stitches n° 2 onto needles n° 3. Knit two rows.
Transfer stitches n° 3 onto needles n° 4. Knit two rows.
Transfer stitches n° 4 onto needles n° 5. Knit two rows *.
Repeat from * to *.

The extra stitches will be transferred afterwards onto the back bed needles in order to have two stitches onto the nearest needles opposite.

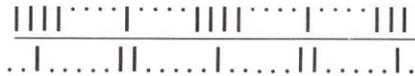

To finish the casting-on, proceed as for the casting-on method in Close Rib.
Flow combs alternate. Carriages at the right-hand side. Stitch size on both carriages as for stocking stitch less one size.

Procedure :

* Selection keys: Back carriage: 
Front carriage: 

Knit 2 rows.
Selection keys: Back carriage: 
Front carriage: 

Knit 2 rows *.
Repeat from * to *.

Stripes

Cast-on in stocking stitch with the main yarn. Carriage at the right-hand side, thread the second yarn without placing it in the yarn guide, but fasten it to the right-hand stud. (Do not use the second yarn guide).

WITH TWO COLOURS

A — Remove the main yarn from the yarn guide and place it into non-working position (*). Thread the yarn guide with the second yarn and knit one row ←.

B — Remove the second yarn from the yarn guide and place it into non-working position (*). Cancel the keys  and pass the carriage from the left-hand side to the right-hand side →.

C — Thread the yarn guide with the main yarn. Depress key , knit one row ←.

D — Remove the main yarn from the yarn guide and place it into non-working position (*). Thread the yarn guide with the second yarn and knit one row →.

E — Remove the second yarn from the yarn guide and place it into non-working position (*). Cancel the keys  and pass the carriage from the right-hand side to the left-hand side ←.

F — Thread the yarn guide with the main yarn. Depress key , knit one row →.

Repeat the operations A to F etc.

NOTE: WATCH CAREFULLY THE TENSION OF BOTH YARNS AND NOTE THAT 3 ROWS ON THE ROW COUNTER CORRESPOND TO 2 KNITTED ROWS.

WITH THREE COLOURS

At the left-hand side place the third yarn opposite to the machine, pass it between the needle beds and fasten it to the left-hand stud.

A — Remove the main yarn from the yarn guide and place it into non-working position (*) (this yarn will not knit during two rows). Thread the yarn guide with the second yarn. Knit one row.

B — Remove the second yarn from the yarn guide and place it into non-working position (*). Thread the yarn guide with the third yarn and hold it slightly with the hand to replace the tension unit. Knit one row.

C — Remove the third yarn from the yarn guide and leave it on the front bed between the flow combs at the edge of the knitting. Thread the yarn guide with the main yarn. Knit one row.

Repeat the operations A to C in order to obtain the required number of rows.

NOTE: IT IS IMPORTANT TO WATCH ALWAYS THE TENSION OF THE YARNS DUE TO THEIR MANUAL MANIPULATION.



(*) Place yarn into non-working position = place it under the upper slide rail on the back bed, at the carriage side.

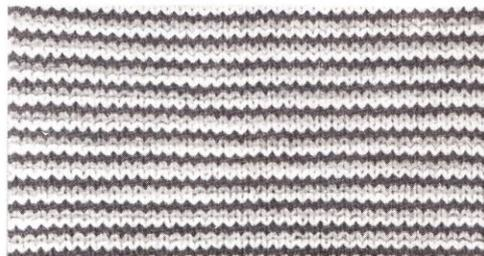

NOTE FOR S.B.: After having knitted 4 to 5 rows attach the knitting retainer and hang weights.

Patterns knitted on front bed using the needle selection buttons

Beginning and casting-on :

NEEDLE BEDS	NEEDLES	POSITION
BACK		
FRONT		N° 1 Normal

CARRIAGES	KEY	STITCH	N.B.B.	N.S.B.	MOVEMENT
BACK					
FRONT		Stocking stitch			

As for stocking stitch caution: casting-on has to be done on the front bed with an even number of needles.

1st and following rows :

Hang weights and set row counter to 000. Do not forget to unfasten the yarn from the stud after a few rows.

PATTERN N° 1:

BACK										
FRONT		STOCKING STITCH + 1								KNIT

PATTERN N° 2:

BACK										
FRONT		STOCKING STITCH								KNIT

PATTERN N° 3:

1st row with carriages at the left-hand side

BACK										
FRONT		STOCKING STITCH								

BACK										
FRONT		STOCKING STITCH								

repeat

1st row with carriages at the right-hand side:

BACK										
FRONT		STOCKING STITCH								

BACK										
FRONT		STOCKING STITCH								

repeat

PATTERN N° 4:

1st row with carriages at the left-hand side

BACK										
FRONT		STOCKING STITCH								

BACK										
FRONT										

BACK										
FRONT										

BACK										
FRONT										

repeat

1st row with carriages at the right-hand side

CARRIAGES	KEY	STITCH	N.B.B.	N.S.B.	MOVEMENT
BACK					
FRONT		STOCKING STITCH			

BACK					
FRONT					

BACK					
FRONT					

BACK					
FRONT					

repeat

Fancy ribs

Beginning :

Closed casting-on in stocking stitch (eg. 4/1 Rib).
Space selector as for 1/1 Rib.
Remove front carriage.
Back carriage at right-hand side.
Hold the mounting comb with wire and place it up between the needle beds.

NEEDLE BEDS	NEEDLES	POSITION
BACK		
FRONT		N° 1 Normal

CARRIAGES	KEY	STITCH	N.B.B.	N.S.B.	MOVEMENT
BACK		Stocking stitch			

Casting-on :

Hang weights.

BACK		
FRONT		No 2 UPPER



1st and following rows :

Space selector as for 1/1 Rib.
 Replace front carriage.
 Transfer the required stitches onto the front bed needles.
 Set row counter to 000 and unfasten the yarn from the stud.

	BACK			
	FRONT		N° 1 Normal
BACK	△ or according to specification	stocking stitch or according to specification	● ● ● ●	KNIT
FRONT	△ or according to specification	stocking stitch or according to specification	● ● ● ● ● ● ● ●	

Casting-off :

See page 35

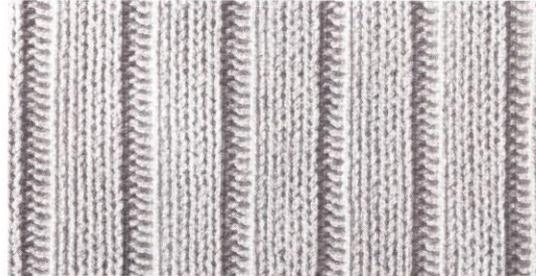

Beginning :

Cast-on as for Close Rib (eg. back bed as for stocking stitch front bed as for 2/3 Rib).
 Space selector as for 1/1 Rib.
 Intermediary lever to the right-hand side.
 Racking lever one notch to the right-hand side.
 Back and front carriages at the right-hand side.

	NEEDLE BEDS	NEEDLES	POSITION		
	BACK				
	FRONT		N° 1 Normal		
CARRIAGES	KEY	STITCH	N.B.B.	N.S.B.	MOVEMENT
BACK	△	↻	● ● ● ●		
FRONT	△	↻	● ● ● ● ● ● ● ●		←

1st and following rows :

a) Intermediary lever to the left-hand side — racking lever one notch to the right-hand side.
 Transfer the front bed stitches which are not required for pattern onto the back bed needles.
 b) Intermediary lever to the right-hand side — racking lever one notch to the left-hand side.
 Set row counter to 000 and unfasten the yarn from the stud.

	BACK		
	FRONT	
BACK	△ or according to specification	stocking stitch or according to specification	KNIT
FRONT	△ or according to specification	stocking stitch or according to specification	

Casting-on :

Place mounting comb, wire and weights.

BACK	↻	3*		→
FRONT	↻	3*		←

Casting-off :

See page 35.

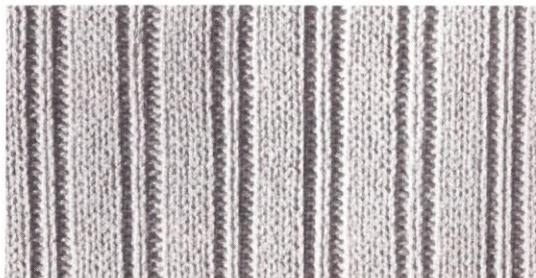

Maintenance and care

The knitting machine needs as any mechanism maintenance and care. As a matter of fact, fluff and dust form a deposit in the needle grooves and inside the carriages. It is therefore necessary to lubricate regularly your knitting machine in order to assure its good functioning.

- A. Using a nylon brush, clean the needle grooves.
- B. Bring all needles into working position 2.
- C. Lubricate slightly the needle heels.
- D. Move the carriages in order to lubricate also the cams, then pass a cloth to remove the dirt which is produced.

As an advice these operations have to be made once a week if the knitter is using the machine every day.

At least every 2 or 3 months by normal use.

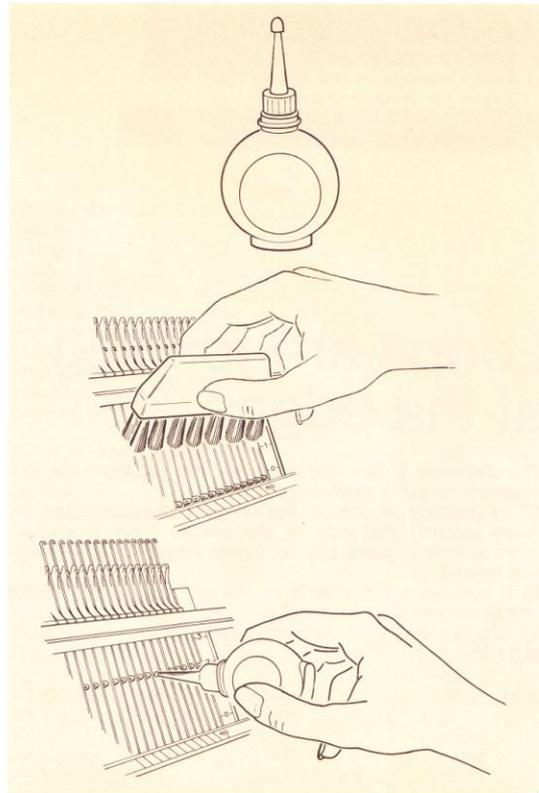

What to do if...

The row counter does not register :

It could happen that the row counter does not register anymore. In this case it is useful to:

- Make sure the screw of the counter arm is well fixed.
- Adjust the counter arm upwards or downwards in order that the row counter registers correctly each row.

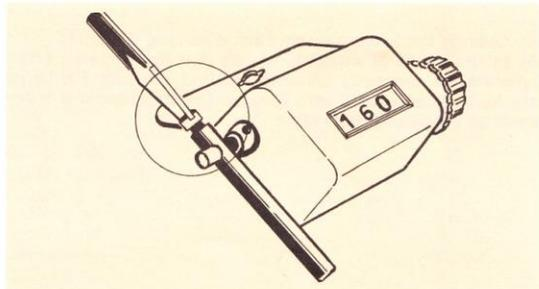

The carriages jam :

- A) Never reverse the carriages when they are already on the needles.
- B) Move the locking levers located on each side of the carriages upwards and tip the carriages outwards.
- C) Bring the carriages back to their starting point and unpick the partly knitted row. Replace the needles in working position 1. If necessary, deduct one row from the row counter.
- D) Make sure the carriages are well locked on the slide rails.

The carriages are hard to push

- A) Either increase or reduce the stitch size.
 - B) Reduce the space selector or the tension.
 - C) Check the needles: if necessary, clean the needle grooves, lubricate slightly the needle heels and operate the carriages without knitting. This operation is recommended after having knitted several garments, at least once every week.
- If the needle is rusty, damaged or doubtful, change it. See page 68.

Stitches drop

- A) Check the position of the front bed:
 - in stocking stitch = upper position n° 2,
 - in rib = normal position n° 1.
- B) Either increase or reduce the stitch size.
- C) Adjust the tension of the yarn.
- D) Check the space selector (rather reduce it).
- E) Add more weights (mainly at the edges).

Stitches are loose on one side and tighten on the other side.

Unfasten the yarn from the stud as the knitting is not coming down in a straight way. It is recommended to unfasten it always after having knitted a few rows.

Loops are forming at the edges

This happens if the carriages are too far from the first needle in working position.

- A) At the end of a row, do not push the carriages too much towards the ends of the needle beds. A clicking noise from the cams can be heard when the last needle has knitted.
- B) If necessary, pull slightly on the yarn behind the tension unit to correct the yarn tension.
- C) Check the yarn tension (see tension adjustment page 15).

Knots (have to be avoided)

A) If there is not enough yarn to knit a row: Fasten the remaining yarn to the stud and rethread a new ball of yarn.

B) If a knot is knitted:

Unlock the carriages (locking levers), undo the partly knitted row, cut the knot, fasten the end of the yarn to the stud and rethread the machine with new yarn.

C) If once the knitting is finished some knots appear in the knitting:

Pass the knots on the purl side in order to make them invisible after completing the garment.

Needles are broken or bent

- A) Change the broken or bent needles (see page 68).
- B) In the event of weaving, check that the weaving effect brushes are correctly inserted i.e. that the round brushes are in front of you. If not, remove the brushes and insert them as explained page 60.

Needle latches are broken or bent (when they pass under the needle hook)

The reason is that in both cases the carriages have been moved without yarn across needles in working position with the second yarn guide fitted on the carriage.

A) Before moving the carriages, make sure the needle latches are well open.

B) Change the needles, see page 68, or using the hook of the latch needle tool put the latch back into place.

Index

	Page		Page
Accessories	5-7	Neckband	53
Armhole and shoulder shaping	21	Necklines	21-22
Assembling	24	Needles	10
		changing	68
Bed position levers	10	in holding position	20
Before knitting	14	Needles: beds	8
Button holes	51	bed opening	23
		positions	11
Care and maintenance	69	return buttons	13
Carriages	11-12	selection buttons	13
Casting-off	35	Norwegian Jacquard	58
Casting-on: chain	18		
1/1 Double sided Fisherman rib	38	Part-row knitting	20
2/2 Double sided Fisherman rib	41	Patterns: fancy	62-66
2/2 Industrial rib	42	racking	61
1/1 Simple rib	16, 36-37	Picking up dropped stitches	23
2/1 Simple rib	43	Pitch lever (1/4)	9
2/2 Simple rib	40	Pockets	54
1/1 Single sided Fisherman rib	39		
Stocking stitch	30-32	Racking : lever	9
Chain casting-off	22	patterns	61
Chain casting-on	18	Remove or re-hang half-knitted work	24
Changing a needle	68	Rib: decreasing	46
Circular stocking stitch	48	close	47
Close rib	47	1/1 Double sided Fisherman rib	38
Conversion kit	3	2/2 Double sided Fisherman rib	41
Conversion table	28-29	fancy	66-68
Coupling catch	12	increasing	45-46
		2/2 Industrial	42
Decreasing	19	1/1 Simple	16,36-37
in Single and Double sided Fisherman rib	46	2/1 Simple	43
in stocking stitch	33-34	2/2 Simple	40
Double bed machine	4	1/1 Single sided Fisherman rib	39
During knitting	22	Row counter	14
Dropped stitches	23		
Fair Isle	57	Sample, test	26
Fancy patterns	62-66	Selection keys	12
Fancy rib	66-68	Semi-circular stocking stitch	49
Finishing	24	Sewing	24
Fisherman rib 1/1 Single, Double	38-39	Shoulder shaping	21
		Single bed machine	3
Garments made to measure	25	Size chart	27
Grafting	24	Socks	55-56
		Space selector	8
Half-knitted work: to remove or re-hang	24	Stitch size dial	12
Hems	52	Stocking stitch	17
Hem-fold	53	casting-on	18, 30-32
Hints before and during knitting	14	casting-off	22,35
Holding position : needles in	20	decreasing	33-34
		increasing	32
Increasing	19	Straight vertical opening	21
and decreasing in 1/1 Simple rib	45		
in Single and Double sided Fisherman rib	46	Tension unit bracket	8
in Stocking stitch	32	Test sample	26
Jacquard	59	Thick yarn	50
Norwegian	58	Threading	15
		Transferring from rib to stocking stitch	17
Levers: bed position	10		
intermediary	9	Undoing one or several rows	23
1/4 pitch (transfer position)	9	Vertical opening	21
racking	9	Weaving effect	60
Maintenance and care	69	What to do if...	69-70
Mock rib	18, 44		