

**The
Kiddies
Chunky
Book**

KNITMASTER
creative KONE
CHUNKY

The *Kiddies* *Chunky* Book

The Kiddies' Chunky Book includes a wonderful selection of children's designs which range from the ever popular and extremely useful classic styles right through to high fashion for children. All of these designs have been knitted on Knitmaster Chunky machines using the gorgeous new Chunky Yarn from Knitmaster — it comes in a terrific range of colours and knits like a dream on all 9mm Chunky machines.

We've included a couple of easy-to-knit starter patterns, so that the children can knit something for themselves, as we're sure they'll want to. Today's machines are so easy to use and children so quick to learn that they'll easily manage to follow our simply written starter patterns and soon be able to knit from the other patterns in this book.

In fact, these easy-to-knit starter patterns will also be ideal for any adults who are new to machine knitting and would like something a little less demanding to start off with.

We hope you and the children enjoy knitting this delightful and comprehensive collection of children's chunky knits as much as we did.

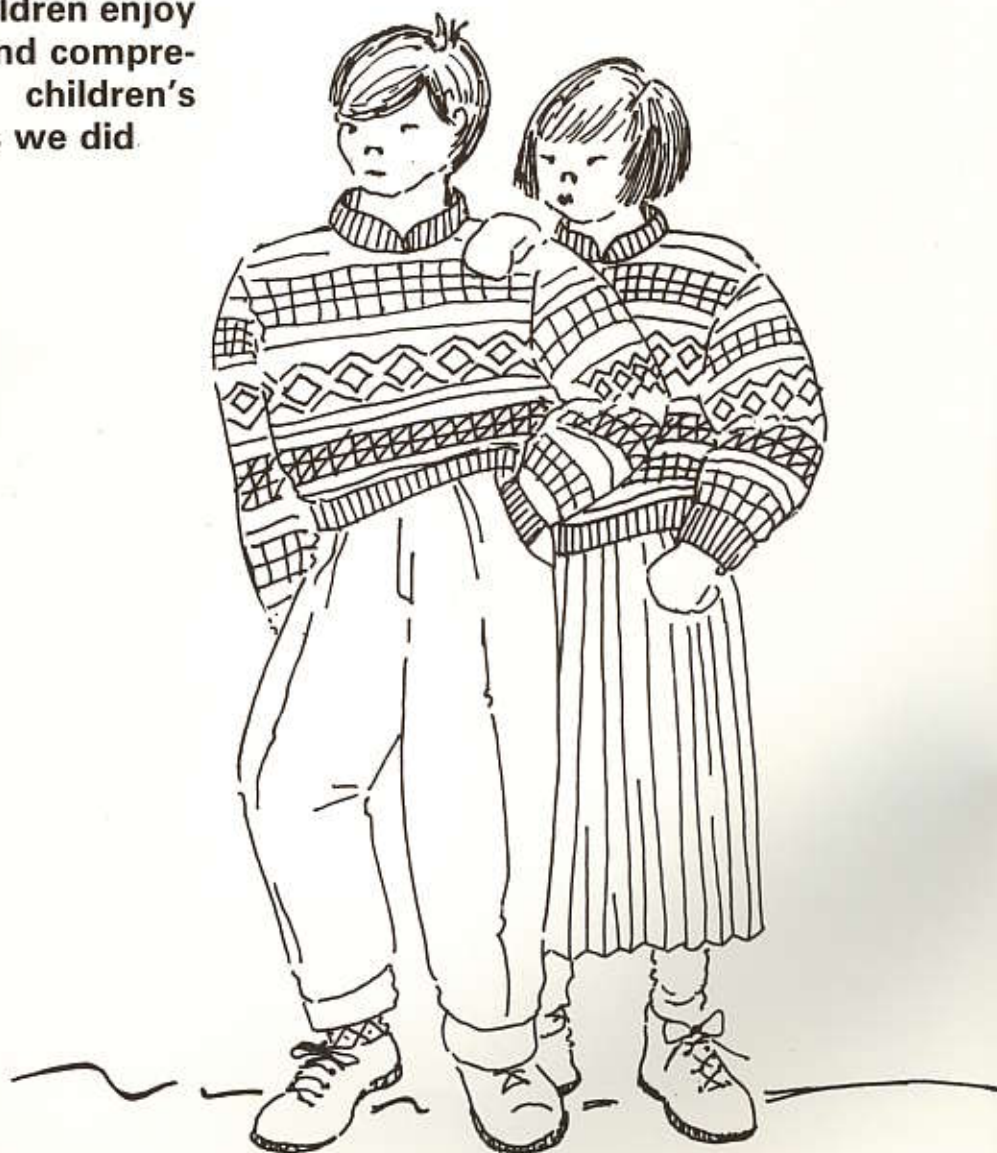

The Kiddies Chunky Book

EDITOR

Laraine McCarthy

DESIGN

Sarah Large

PATTERNS

Debbie Clarkson

KNITTING

Helen Bacon

Susan King

PHOTOGRAPHY

Liz McAulay

STYLIST

Kate Mullaney

ACCESSORIES

Denims

Dungarees

Denim Jackets

Denim Skirts

— Hennes

(Marble Arch and branches)

Hats — The Hat Shop

(St. Christopher's Place)

Shoes — Red or Dead

(Rupert St. Soho)

Children's World (Benetton)

CONTENTS

1	Striped Roll Neck Sweater	6
2	Plain Slashneck Sweater	7
3	Saddle Crew & V-Neck Sweaters & Cardigans	8
4	Intarsia Jacket	10
5	Set in Sleeve Crew & V-Neck Sweaters & Cardigans	13
6	Aran Crew Neck Sweater & Cardigan	16
7	Raglan Crew & V-Neck Sweaters & Cardigans	19
8	Drop Shoulder Crew & V-Neck Sweaters & Cardigans	25
9	Nautical Sweaters	28
10	Cable Cardigan with Flowers	29
11	Rose Sweater	32
12	Cardigan with Floral Border	33
13	Chequered Sweaters with Motif	35
14	Chequered Cardigan with Motif	36
15	Geometric Garter Stitch Sweater	39
16	Shawl Collar Cable Sweater with Motif	42
	Abbreviations	7
	Additional Notes & Information	24

Although every reasonable care has been taken to ensure that the instructions and designs in this pattern book are correct. Modern Knitting Ltd. cannot accept responsibility for any errors which may have occurred in spite of such precautions. All rights reserved. Reproduction in whole or part without written permission is strictly prohibited.

A Modern Knitting Publication © 1988
Modern Knitting is a Registered Trademark
Printed by E E Owens & Co Ltd.

SUITABLE FOR KNITMASTER CHUNKY MACHINES

The designs in the Kiddies Chunky Book are suitable for use with all Knitmaster 9mm Chunky Machines — Model nos. 150, 151, 155 and Zippy 90.

KNITMASTER YARN STOCKIST

If you encounter any problems in obtaining Knitmaster Chunky Yarn, please write for stockist information to Knitmaster Ltd., 39-45 Cowleaze Rd., Kingston-upon-Thames, Surrey KT2 6DT.

1



2





3

1 STRIPED ROLL NECK SWEATER



Children are more than capable of using today's easy-to-operate knitting machines but often find that the usual form of knitting pattern, with all its abbreviations and technical jargon, is too offputting. So, we've produced these first two simple patterns in an easy-to-follow pattern style which will allow the children to knit their own sweaters and, at the same time, familiarise themselves with some of the technicalities of a knitting pattern. Once they've knitted these patterns, children should be ready to attempt some of the other simple patterns in this book which are written in the normal pattern style. We have included a striped and plain version of these simple starter patterns and have varied the neckline slightly. We recommend that children start with the plain version and then have a go at the striped version.

BACK & FRONT ALIKE

Push 25 (27) (29) (31) Needles at left and right of centre O to Holding Position.

See our chart on page 24 for an explanation of each of the needle positions.

Using colour 2, cast on.

Your Instruction Book will give you detailed instructions for casting on.

Push Needles to Upper Working Position. Row Counter 000. Tension Dial at 5, knit 7 rows. Tension Dial at 8, knit 1 row. Row Counter 000. Tension Dial at 6. Continue in stripes of 4 rows colour 1, 4 rows col 2 throughout. Knit 48 (52) (58) (62) rows. Mark both edges with waste yarn for armhole position.

Putting a waste yarn marker in at each side of your knitting at this stage will show you where the sleeves should be

For Knitmaster 9mm Chunky Machines.

Sizes:

To fit 61 (66) (71) (76) centimetres/24 (26) (28) (30) inch chest.

The figures in brackets represent the larger sizes. You should take your instructions from the same bracket throughout the pattern. For instance, if you are knitting size 28" chest which is in the 2nd bracket, always take your knitting instructions from the 2nd bracket.

Materials:

Knitmaster Chunky

Col 1 (Midnight) — 125 (145) (160) (175) grms

Col 2 (Serpentine) — 125 (145) (160) (175) grms

Tension:

Stockinet — 15 sts and 22 rows to 10 centimetres. Tension Dial at approximately 6.

Notice that we say the Tension Dial is at approximately 6. Each machine will knit at a slightly different tension — perhaps 5 or maybe 6. You must knit a tension swatch (or maybe as many as 3 or 4) to find which tension dial setting will give you the same stitches and rows to 10 centimetres as we have. It's very important that you have the same if your sweater is to come out to the correct size. Your instruction Book will tell you how to knit a tension square.

Pattern Note:

Striped stockinet. 4 rows col 1, 4 rows col 2.

Stripes are a nice easy way of introducing a 2nd colour or maybe even a 3rd or 4th colour if you like. Simply change the colour of yarn you are knitting with each time.

positioned when you come to make up your sweater. You'll find details of how to do this in your Instruction Book.

Knit to Row 86 (92) (100) (106). Cast off 10 (12) (13) (15) stitches at beginning of the next row, knit 1 row.

Your Instruction Book shows you in detail how to cast off.

Cast off 10 (12) (13) (15) stitches at beginning of the next row, knit 1 row. 30 (30) (32) (32) Needles remain in Working Position. Mark both ends with waste yarn. Knit to Row 104 (110) (118) (124). Cast off.

SLEEVES

Push 13 (13) (14) (14) Needles at left and right of centre O to Holding Position. Using colour 1, cast on. Push Needles to Upper Working Position. Row Counter 000. Tension Dial at 6. Continue in stripes of 4 rows col 1, 4 rows col 2 throughout, knit 22 rows. Row Counter 000. Increase 1 stitch at both ends of the next and every following 4th (4th) (5th) (5th) row until you have 50 (54) (56) (60) stitches.

Your Instruction Book shows you in detail how to increase a single stitch.

Knit straight until Row Counter shows 55 (63) (68) (77). Mark the centre with waste yarn. Cast off.

TO MAKE UP

Pin out to size and steam carefully. Join shoulder seams to marked points.

You can join the shoulders by sewing them with a normal back stitch or graft them as explained in your Instruction Book.

Set in sleeves between marked points.

Sew the top of the sleeves to the body pieces using a normal back stitch.

Join side and sleeve seams.

Sew side seams and sleeve seams together using a normal back stitch or blind stitch hem following the instructions given in your Instruction Book.

Allow cuff to roll back onto the outside and catch down into position. Turn hem to inside and catch down into position. Allow neck to roll to the outside. Give final light steam.

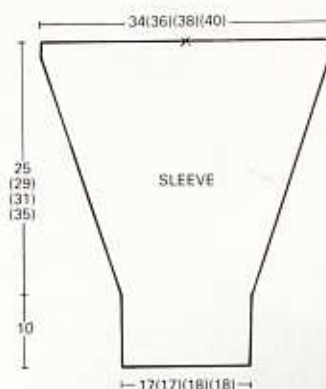
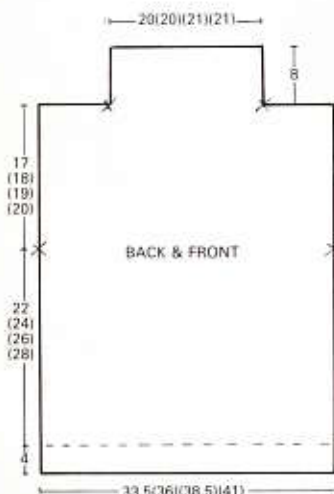

2 PLAIN SLASHED NECK SWEATER



For Knitmaster 9mm Chunky Machines.

Sizes:

To fit 61 (66) (71) (76) centimetres/24 (26) (28) (30) inch chest.

The figures in brackets represent the larger sizes. You should take your instructions from the same bracket throughout the pattern. For instance, if you are knitting size 28" chest which is in the 2nd bracket, always take your knitting instructions from the 2nd bracket.

Materials:

Knitmaster Chunky
Col 1 (Serpentine) — 250 (290) (320) (350) grms

Tension:

Stockinet — 15 sts and 22 rows to 10

centimetres. Tension Dial at approximately 6.

Notice that we say the Tension Dial is at approximately 6. Each machine will knit at a slightly different tension — perhaps 5- or maybe 6. You must knit a tension swatch (or maybe as many as 3 or 4) to find which tension dial setting will give you the same stitches and rows to 10 centimetres as we have. It's very important that you have the same if your sweater is to come out to the correct size. Your instruction Book will tell you how to knit a tension square.

Pattern Note:

Stockinet

BACK & FRONT ALIKE

Push 25 (27) (29) (31) Needles at left and right of centre O to Holding Position.

See our chart on page 24 for an explanation of each of the needle positions.

Using colour 1, cast on.

Your Instruction Book will give you detailed instructions for casting on.

Push Needles to Upper Working Position. Row Counter 000. Tension Dial at 5, knit 7 rows. Tension Dial at 8, knit 1 row. Row Counter 000. Tension Dial at 6. Knit 48 (52) (58) (62) rows. Mark both edges with waste yarn for armhole position.

Putting a waste yarn marker in at each side of your knitting at this stage will show you where the sleeves should be positioned when you come to make up your sweater. You'll find details of how to do this in your Instruction Book.

Knit to Row 86 (92) (100) (106). Using waste yarn mark the 15th (15th) (16th) (16th) stitch at both sides of centre O. Tension Dial at 10, knit 1 row. Cast off.

SLEEVES

Push 13 (13) (14) (14) Needles at left and right of centre O to Holding Position. Using colour 1, cast on. Push Needles to Upper Working Position. Row Counter 000. Tension Dial at 6. Knit 22 rows. Row Counter 000. Increase 1 stitch at both ends of the next and every following 4th (4th) (5th) (5th) row until you have 50 (54) (56) (60) stitches.

Your Instruction Book shows you in detail how to increase a single stitch.

Knit straight until Row Counter shows 55 (63) (68) (77). Mark the centre with waste yarn. Cast off.

TO MAKE UP

Pin out to size and steam carefully. Join shoulder seams to marked points.

You can join the shoulders by sewing them with a normal back stitch or graft them as explained in your Instruction Book.

Set in sleeves between marked points.

Sew the top of the sleeves to the body pieces using a normal back stitch.

Join side and sleeve seams.

Sew side seams and sleeve seams together using a normal back stitch or blind stitch hem following the instructions given in your Instruction Book.

Allow cuff to roll back onto the outside and catch down into position. Turn hem to inside and catch down into position. Allow neck to roll to the outside. Give final light steam.

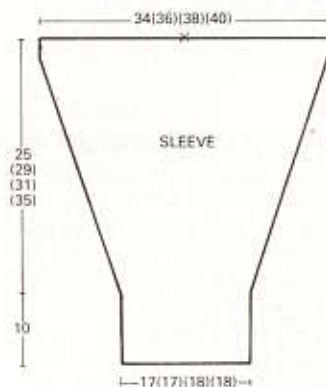
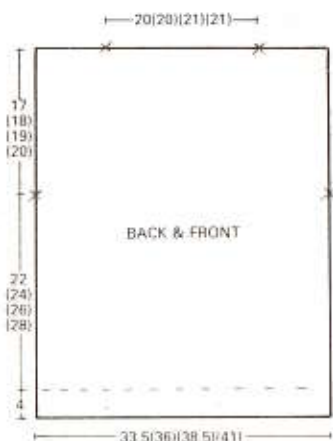

ABBREVIATIONS

Alt	— Alternate	NWP	— Non Working Position
Altog	— Altogether	Patt	— Pattern
Approx	— Approximately	Pos	— Position
Beg	— Beginning	Rept	— Repeat
Carr	— Carriage	Rem	— Remaining
Cm(s)	— Centimetre(s)	RC	— Row Counter
Dec	— Decrease	St	— Stitch
Ev	— Every	Sts	— Stitches
Foll	— Following	TD	— Tension Dial
HP	— Holding Position	Tog	— Together
Inc	— Increase	UWP	— Upper Working Position
MT	— Main Tension	WP	— Working Position
N	— Needle		
Ns	— Needles		

3 SADDLE SHOULDER CREW & V-NECK SWEATER & CARDIGAN



Here are 4 classic saddle shoulder designs which you can knit time and time again. Our photo shows the crew neck versions of the sweater and cardigan but the pattern also includes instructions for v-neck sweaters and cardigans. Knit them plain, as we have, or decorate them with any of the embroidery or Swiss Darned motifs which are included in this book.

BACK

Push 45 (48) (51) (54) Ns to WP. Cast on as given in additional notes for Knit 1 Purl 1 Rib. RC 000. MT-5, knit 10 rows. Drop the 3rd and ev foll alt st and pick up as for Knit 1 Purl 1 Rib. Cast off with waste yarn. Push 25 (27) (29) (31) Ns at left and right of centre O to WP. 50 (54) (58) (62) Ns altog. With carr at right pick up sts from below waste yarn and place onto Ns increasingly evenly. RC 000. MT. Using col 1, knit 48 (52) (58) (62) rows. Mark both ends with waste yarn*. Knit 27 (29) (31) (33) rows.

Shape Shoulders

Dec 1 st at both ends of the next and ev foll 3rd (alt) (alt) (alt) row 3 (4) (4) (3) times in all. Dec 1 st at both ends of the next 2 (2) (2) (4) rows. RC 84 (90) (98) (104). Mark the 8th st at left and right of centre O with waste yarn. Cast off rem 40 (42) (46) (48) sts.

CREW NECK SWEATER

FRONT

Knit as for Back to *. Knit 16 (18) (20) (20) rows.

Shape Shoulders

Dec 1 st at both ends of the next and ev foll 3rd (alt) (alt) (alt) row 3 (4) (4) (3) times in all. Dec 1 st at both ends of the next 2 (2) (2) (4) rows. RC 73 (79) (87) (91). Mark the 6th st at left and right of centre O with waste yarn. Cast off rem 40 (42) (46) (48) sts.

For Knitmaster 9mm Chunky Machines.

Sizes:

To fit 61 (66) (71) (76) cms/24 (26) (28) (30) inch chest.

Materials:

Knitmaster Chunky. Colours shown Cloud Blue and Pink

Sweater

Col 1 - 260 (290) (320) (350) grms

Cardigan

Col 1 - 270 (300) (330) (360) grms

Crew Neck Cardigan - 8 (8) (9) (9) buttons.

V-Neck Cardigan - 6 (6) (7) (7) buttons.

Tensions:

Stockinet - 15 sts and 22 rows to 10 cms. TD at approx. 6 (MT)

Knit 1 Purl 1 Rib - 27 rows to 10 cms. TD at approx. MT-5

Pattern Note:

Stockinet

LEFT SLEEVE

Push 13 (13) (14) (14) Ns at left and right of centre O to WP. 26 (26) (28) (28) Ns altog. Cast on as given in additional notes for Knit 1 Purl 1 Rib. RC 000. MT-5, knit 10 rows. Drop the 3rd and ev foll alt st and pick up as for Knit 1 Purl 1 Rib. RC 000. MT. Knit 2 rows. Inc 1 st at both ends of the next and ev foll 4th row 8 (7) (7) (7) times in all, knit 3 rows. Inc 1 st at both ends of the next and ev foll 5th row 5 (7) (8) (9) times in all. 52 (54) (58) (60) sts. Knit to Row 56 (64) (68) (78). Carr at right. Knit 1 row extra for Right Sleeve*. **Shape Saddle Shoulder

Cast off 11 (12) (14) (14) sts at beg of the next row and 18 (19) (21) (22) sts at beg of the next row. Cast off 2 sts at beg of the next 2 rows. Dec 1 st at both ends of the next 2 rows. Knit 0 (0) (1) (1) row. Dec 1 st at both ends of the next and foll alt row. 11 (11) (11) (12) sts. Knit 12 (14) (17) (19) rows. Carr at left.

Shape Neck Edge

Using a length of col 1, cast off 5 (5) (5) (6) sts at right of centre O. Hold Ns at right.

Knit Left Part as Follows:-

Knit 2 rows. Dec 1 st at neck edge on the next row, knit 1 row. Fasten off rem st. Take carr to right. Bring Ns back to WP.

Knit Right Part as Follows:-

Knit 1 row. Dec 1 st at beg of the next and ev foll alt row 3 times in all, knit 1 row. Fasten off rem st**.

RIGHT SLEEVE

Knit as for Left Sleeve to * noting alteration in number of rows worked, then from **to** reading left for right and vice versa.

NECKBAND

Push 60 (60) (60) (63) Ns to WP. Cast on as given in additional notes for Knit 1 Purl 1 Rib. RC 000. MT-5, knit 15 rows. Drop the 3rd and ev foll alt st and pick up as for Knit 1 Purl 1 Rib. Knit 1 row MT. Cast off with waste yarn.

TO MAKE UP

Pin out to size and steam carefully. Set in sleeves and sew saddle shoulders into pos between marked points. Join side and sleeve seams. Backstitch neckband into pos and join centre back neck seam. Fold in half and catch down on the inside. Give final light steam.

V-NECK SWEATER

FRONT

Knit as for Back to*

Shape Neck

Hold Ns at left.

Knit Right Part as Follows:-

Dec 1 st at neck edge on the next and ev foll 3rd (3rd) (3rd) (4th) row 6 (5) (3) (6) times in all.

2nd Size Only

Knit 3 rows. Dec 1 st at neck edge on the next row.

3rd Size Only

Knit 3 rows. Dec 1 st at neck edge on the next and ev foll 4th row 3 times in all.

All Sizes

Knit 0 (1) (1) (1) row.

Shape Shoulder

Dec 1 st at right edge on the next row, knit 1 row.

1st Size Only

Dec 1 st at neck edge on the next row. Dec 1 st at right edge on the next row, knit 2 rows.

2nd & 3rd Sizes

Dec 1 st at both ends of the next row, knit 1 row. Dec 1 st at right edge on the next row, knit 1 row.

4th Size Only

Dec 1 st at both ends of the next row, knit 1 row. Dec 1 st at right edge on the next 2 rows.

All Sizes

Dec 1 st at both ends of the next row. Dec 1 st at right edge on the next 2 rows. Mark neck edge with waste yarn.

Cast off rem 12 (13) (15) (16) sts. Take carr to left. Bring Ns back to WP. Knit left part as for right part but read left for right.

LEFT SLEEVE

Knit as for Left Sleeve of Crew Neck Sweater to*.

**Shape Saddle Shoulder

Cast off 11 (12) (14) (15) sts at beg of the next row and 18 (19) (21) (22) sts at beg of the next 2 rows. Dec 1 st at both ends of the next 2 rows. Knit 0 (0) (1) (1) row. Dec 1 st at both ends of the next and foll alt row. 11 sts. Knit 12 (14) (17) (19) rows. Carr at left.

Shape Neck Edge

Using a length of col 1, cast off 5 sts at right of centre O. Hold Ns at right.

Knit Left Part as Follows:-

Knit 2 rows. Dec 1 st at neck edge on the next row, knit 1 row. Fasten off rem st. Take carr to right. Bring Ns back to WP.

Knit Right Part as Follows:-

Knit 1 row. Cast off 2 sts at beg of the next row, knit 1 row. Dec 1 st at beg of the next row. Fasten off rem st**

RIGHT SLEEVE

Knit as for Left Sleeve to * noting alteration in number of rows worked then from **to** reading left for right and vice versa.

NECKBAND

Push 78 (81) (84) (87) Ns to WP. Cast on as given in additional notes for Knit 1 Purl 1 Rib. RC 000. MT-5, knit 9 rows. Drop the 3rd and ev foll alt st and pick up as for Knit 1 Purl 1 Rib. Knit 1 row MT. Cast off with waste yarn.

TO MAKE UP

Pin out to size and steam carefully. Set in sleeves and sew saddle shoulders into pos between marked points. Join side and sleeve seams. Backstitch neckband into pos overlapping at centre front. Give final light steam.

CREW NECK CARDIGAN

RIGHT FRONT

Push 22 (24) (26) (27) Ns to WP. Cast on as given in additional notes for Knit 1 Purl 1 Rib. RC 000. MT-5, knit 10 rows. Drop the 3rd and ev foll alt st and pick up as for Knit 1 Purl 1 Rib. Cast off with waste yarn. Push 25 (27) (29) (31) Ns to WP. With carr at right pick up sts from below waste yarn and place onto Ns increasing evenly. RC 000. MT. Using col 1, knit 48 (52) (58) (62) rows. Mark right edge with waste yarn*. Knit 16 (18) (20) (20) rows.

Shape Shoulder

Dec 1 st at right edge on the next and ev foll 3rd (alt) (alt) (alt) row 3 (4) (4) (3) times in all. Dec 1 st at right edge on the next 2 (2) (2) (4) rows. RC 73 (79) (87) (91). Mark the 6th st from left edge with waste yarn. Cast off rem 20 (21) (23) (24) sts.

LEFT FRONT

Knit as for Right Front but read left for right and vice versa.

SLEEVES

Knit as for sleeves on Crew Neck Sweater

NECKBAND

Knit as for Neckband on Crew Neck Sweater.

BUTTONHOLE BAND

Push 59 (63) (68) (71) Ns to WP. Cast on as given in additional notes for Knit 1 Purl 1 Rib. RC 000. MT-5, knit 5 rows. Drop the 3rd and ev foll alt st and pick up as for Knit 1 Purl 1 Rib. Make 8 (8) (9) (9) evenly spaced buttonholes over 1 N. Knit 4 rows. Drop the 3rd and ev foll alt st and pick up as for Knit 1 Purl 1 Rib. Knit 1 row MT. Cast off with waste yarn.

BUTTON BAND

Knit as for Buttonhole Band but omit buttonholes.

TO MAKE UP

Pin out to size and steam carefully. Set in sleeves and sew saddle shoulders into pos between marked points. Join side and sleeve seams. Backstitch neckband into pos. Fold in half and catch down on the inside. Backstitch front bands into pos. Sew on buttons to correspond with buttonholes. Give final light steam.

V-NECK CARDIGAN

RIGHT FRONT

Knit as for Right Front of Crew Neck Cardigan to*.

Shape Front Edge

Dec 1 st at left edge on the next and ev foll 3rd (3rd) (3rd) (4th) row 6 (5) (3) (6) times in all.

2nd Size Only

Knit 3 rows. Dec 1 st at left edge on the next row.

3rd Size Only

Knit 3 rows. Dec 1 st at left edge on the next and ev foll 4th row 3 times in all.

All Sizes

Knit 0 (1) (1) (1) row.

Shape Shoulder

Dec 1 st at right edge on the next row, knit 1 row.

1st Size Only

Dec 1 st at left edge on the next row.

Dec 1 st at right edge on the next row, knit 2 rows.

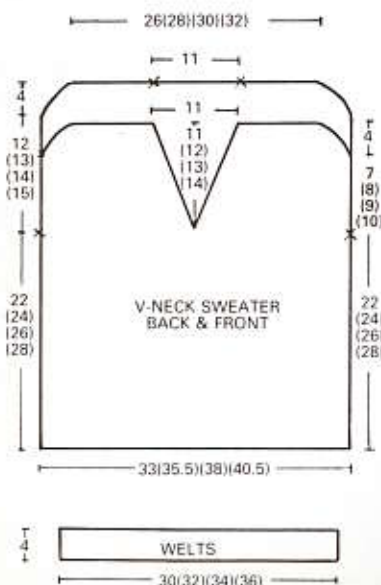

2nd & 3rd Sizes Only

Dec 1 st at both ends of the next row, knit 1 row. Dec 1 st at right edge on the next row, knit 1 row.

4th Size Only

Dec 1 st at both ends of the next row, knit 1 row. Dec 1 st at right edge on the next 2 rows.

All Sizes

Dec 1 st at both ends of the next row. Dec 1 st at right edge of the next 2 rows. Mark neck edge with waste yarn. Cast off rem 12 (13) (15) (16) sts.

LEFT FRONT

Knit as for Right Front but read left for right and vice versa.

SLEEVES

Knit as for Sleeves on V-Neck Sweater.

BACK NECKBAND

Push 24 Ns to WP. Cast on as given in additional notes for Knit 1 Purl 1 Rib. RC000. MT-5, knit 9 rows. Drop the 3rd and ev foll alt st and pick up as for Knit 1 Purl 1 Rib. Knit 1 row MT. Cast off with waste yarn.

BUTTONHOLE BAND

Push 68 (72) (77) (81) Ns to WP. Cast on as given in additional notes for Knit 1 Purl 1 Rib. RC 000. MT-5, knit 5 rows. Drop the 3rd and ev foll alt st and pick up as for Knit 1 Purl 1 Rib. Make 6 (6) (7) (7) evenly spaced buttonholes over 1 N on 39 (42) (45) (48) Ns at right. Knit 4 rows. Drop the 3rd and ev foll alt st and pick up as for Knit 1 Purl 1 Rib. Knit 1 row MT. Cast off with waste yarn.

BUTTON BAND

Knit as for Buttonhole Band but omit buttonholes.

TO MAKE UP

Pin out to size and steam carefully. Set in sleeves and sew saddle shoulders into pos between marked points. Join side and sleeve seams. Backstitch neckband into pos. Backstitch front bands into pos and join seams. Sew on buttons to correspond with buttonholes. Give final light steam.

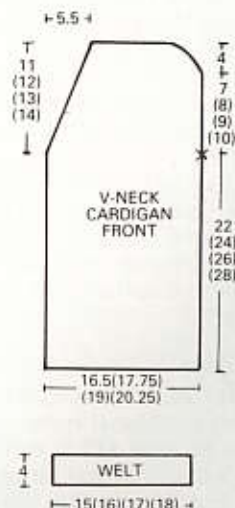

Continued on page 22

4 INTARSIA JACKET



For Knitmaster 9mm Chunky Machines with Intarsia Carriage.

Sizes:

To fit 61 (66) (71) (76) cms/24 (26) (28) (30) inch chest.

Materials:

Knitmaster Chunky.
 Col 1 (Serpentine) – 90 (100) (110) (120) grms
 Col 2 (Geranium) – 90 (100) (110) (120) grms
 Col 3 (Bluebell) – 90 (100) (110) (120) grms
 Col 4 (Black) – 130 (140) (150) (160) grms

Col 5 (White) – 90 (100) (110) (120) grms

1.20 metres 115 cms wide printed cotton for lining; 16 (17) (18) (19) inch chunky open ended zip fastener; elastic to fit cuffs.

Tensions:

Intarsia – 15 sts and 22 rows to 10 cms. TD at approx. 6 (MT)
 Knit 1 Purl 1 Rib – 27 rows to 10 cms. TD at approx. MT-5

Pattern Note:

Intarsia – see chart.

This brightly coloured zip-up jacket has been knitted in intarsia and we have lined it with an equally colourful cotton fabric to give it a more professional finish. However, you can just as easily knit a plain, unlined version if you like or a plain version with a colourful lining would be quite effective.

BACK

Push 45 (48) (51) (54) Ns to WP. Cast on as given in additional notes for Knit 1 Purl 1 Rib. RC 000. MT-5. Knit 16 rows. Drop the 3rd and ev foll alt st and pick up as for Knit 1 Purl 1 Rib. Using waste yarn knit several rows and release from machine. Push 27 (29) (31) (33) Ns at left and right of centre O to WP. 54 (58) (62) (66) Ns altog. With carr at right, pick up sts from below waste yarn and place onto Ns increasing evenly. RC 000. MT. Continue in Intarsia. Knit 46 (50) (54) (58) rows. Mark both ends with waste yarn. Knit 38 (40) (42) (44) rows. RC 84 (90) (96) (102). Carr at right.

Shape Back Neck

Note pos in pattern. Using a length of appropriate col, cast off centre 16 sts. Hold Ns at left.

Knit Right Part as Follows:-

Knit 1 row. Cast off 3 sts beg next row. Cast off rem 16 (18) (20) (22) sts. Take carr to left. Bring Ns back to WP. Keeping pattern correct, knit left part as for right part.

RIGHT FRONT

Push 22 (24) (26) (28) Ns to WP. Cast on as given in additional notes for Knit 1 Purl 1 Rib. RC 000. MT-5, knit 16 rows. Drop the 3rd and ev foll alt st and pick up as for Knit 1 Purl 1 Rib. Using waste yarn knit several rows and release from machine. Push 27 (29) (31) (33) Ns right of centre O to WP. With carr at right, pick up sts from below waste yarn and

place onto Ns increasing evenly. RC 000. MT. Continue in Intarsia. Knit 46 (50) (54) (58) rows. Mark right edge with waste yarn. Knit 25 (27) (27) (29) rows. RC 71 (77) (81) (87). Carr at left.

Shape Neck

Cast off 4 sts at beg of the next row, knit 1 row. Cast off 3 sts at beg of the next row, knit 1 row. Cast off 2 sts beg of the next row, knit 1 row. Dec 1 st beg of the next and foll alt row, knit 6 (6) (8) (8) rows. Cast off rem 16 (18) (20) (22) sts.

LEFT FRONT

Knit as for Right Front but reverse the shapings by reading left for right and vice versa.

SLEEVES

Push 25 (25) (27) (27) Ns to WP. Cast on as given in additional notes for Knit 1 Purl 1 Rib. RC 000. MT-5, knit 8 rows. Drop the 3rd and ev foll alt st and pick up as for Knit 1 Purl 1 Rib. Using waste yarn knit several rows and release from machine. Push 14 (14) (15) (15) Ns at left and right of centre O to WP. 28 (28) (30) (30) Ns altog. Pick up sts from below waste yarn and place onto Ns increasing evenly. RC 000. MT. Continue in Intarsia. Knit 4 rows. Inc 1 st at both ends of the next and ev foll 4th row 13 (15) (15) (17) times in all. 54 (58) (60) (64) sts. Knit to Row 57 (65) (70) (79). Mark centre with waste yarn. Cast off.

NECKBAND

Push 63 (63) (65) (65) Ns to WP. Using col 4, cast on as given in additional notes for Knit 1 Purl 1 Rib. RC 000. MT-5, knit 16 rows. Knit 2 rows col 2, 2 rows col 1. Drop the 3rd and ev foll alt st and pick up as for Knit 1 Purl 1 Rib. Knit 1 row MT col 1. Cast off with waste yarn.

TO MAKE UP

Pin out to size and steam carefully. Join shoulder seams. Set in sleeves between marked points. Join side and sleeve seams. Backstitch neckband into pos, fold in half and catch down on the inside. Line jacket if desired using knitted pieces as a pattern plus 1" seam

allowance and an additional 5cm at centre back and sleeves to form a pleat for movement. Make a small casing at cuff edge and thread elastic through casing. Sew on zip fastener.

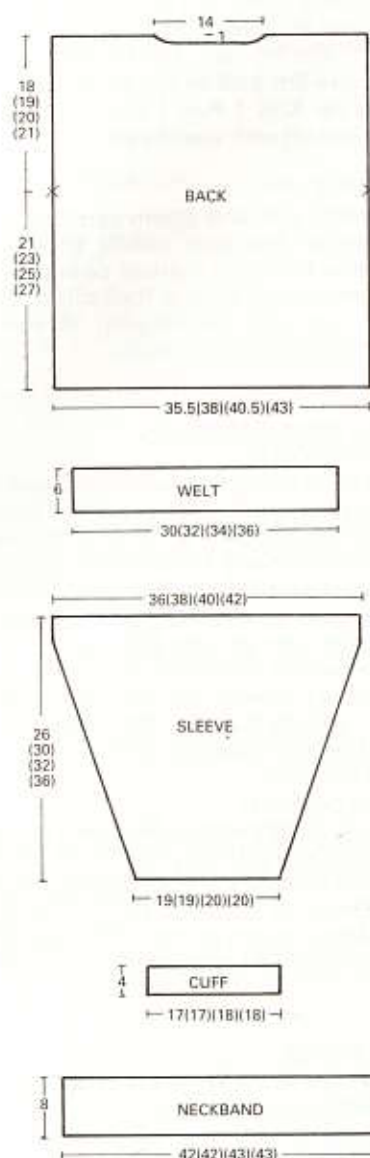

Continued on page 12



4

PATTERN 4
Continued from page 10

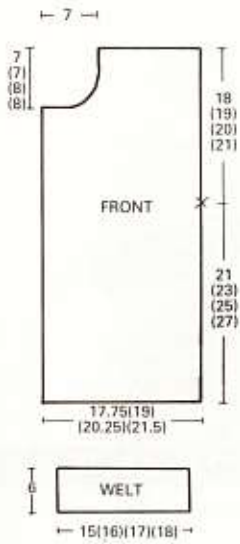

INTARSIA CHART - BACK & FRONTS

	3	4	5	4	5	4	5	4	5	4	5	4	5	3	
86(92)(98)(104)															
74(77)(80)(83)	4													4	
70(73)(76)(79)	5													5	
65(68)(71)(74)	4													4	
61(64)(67)(70)	5	12S			6S		6S			12S			5		
56(59)(62)(65)	4												4		
52(55)(58)(61)	5												5		
47(50)(53)(56)	4												4		
43(46)(49)(52)	5	1			2		2			1			5		
39(41)(44)(47)	4												4		
34(37)(40)(43)	5												5		
29(32)(35)(38)	4												4		
25(28)(31)(34)	5	12S			6S		6S			12S			5		
20(23)(26)(29)	4												4		
	5												5		
	3	4	5	4	5	4	5	4	5	4	5	4	5	3	
	9S	3S	3S	3S	3S	3S	3S	3S	3S	3S	3S	3S	3S	9S	
	2												2		
	1	27S								27S			1		

S = Stitches

INTARSIA CHART - SLEEVES

	3	4	5	4	5	4	5	4	5	4	5	4	5	3	
57(65)(70)(79)															
54	4													4	
50	5													5	
45	4													4	
41	5	3			1		1			3				5	
36	4													4	
32	5													5	
27	4													4	
23	5	1			2		2			1				5	
18	4													4	
13	5													5	
9	4													4	
5	5	3			1		1			3				5	
000	4													4	
	5													5	

Don't *you* deserve **KNITMASTER'S** amazing MasterGlide **700?**

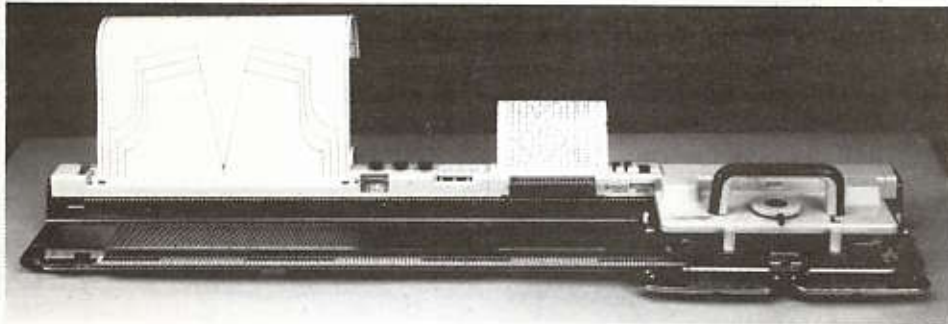

Wonderful knitwear starts with wonderful machines. If you want the best knitwear, you deserve one of the best machines.

Complement your Chunky machine with a superb Knitmaster Standard Gauge, punchcard machine. Knitmaster's Master Glide 700 knits all those lovely finer yarns — 2ply, 3ply, 4ply Plain and fancy yarns.

Knitmaster's Master Glide 700 knits an incredible range of stitch patterns — stocking stitch, Fair Isle, tuck and slip stitch, weaving, plating, single motif and intarsia. Add Knitmaster's unique single action transfer lace carriage for the prettiest lace imaginable.

Knitmaster's 700 features Master Glide roller bearings to make your knitting flow like a dream.

You deserve a Knitmaster MasterGlide 700 machine — there's one waiting for you at your local Knitmaster stockist now.



5 SET IN SLEEVE CREW AND V-NECK SWEATER AND CARDIGAN



This pattern includes instructions for 4 classic set in sleeve chunky designs. We've photographed the crew neck sweater and cardigan but we also give instructions for v-neck sweaters and cardigans. These 4 designs will be ideal for schoolwear or, by introducing stripes of colour or perhaps Swiss Darning a motif, you'll find they're equally suited to children's fashion.

BACK

Push 45 (48) (51) (54) Ns to WP. Cast on as given in additional notes for Knit 1 Purl 1 Rib. RC 000. MT-5, knit 10 rows. Drop the 3rd and ev foll alt st and pick up as for Knit 1 Purl 1 Rib. Cast off with waste yarn. Push 25 (27) (29) (31) Ns at left and right of centre O to WP. 50 (54) (58) (62) Ns altog. With carr at right pick up sts from below waste yarn and place onto Ns increasingly evenly. RC 000. MT. Using col 1**, knit 48 (52) (58) (62) rows. Carr at right.

Shape Armholes

Cast off 2 sts beg next 2 rows. Dec 1 st at both ends of the next and ev foll 4th row 3 (4) (4) (5) times in all. 40 (42) (46) (48) sts*. Knit to Row 82 (88) (96) (102). Carr at right.

Shape Back Neck & Shoulder

Using a length of col 1, cast off centre 14 sts. Hold Ns at left.

Knit Right Part as Follows:-

Cast off 5 (6) (7) (7) sts beg next row, 3 sts beg next row. Cast off rem 5 (5) (6) (7) sts. Take carr to left. Bring Ns back to WP. Knit left part as for right part.

SLEEVES

Push 26 (26) (27) (27) Ns to WP. Cast on as given in additional notes for Knit 1 Purl 1 Rib. RC 000. MT-5, knit 10 rows. Drop the 3rd and ev foll alt st and pick up as for Knit Purl 1 Rib. RC 000. MT. Knit 2 rows. Inc 1 st at both ends of the next and ev foll 5th row 10 (12) (13) (15) times in all. 46 (50) (53) (57) sts. Knit to

For Knitmaster 9mm Chunky Machines.

Sizes:

To fit 61 (66) (71) (76) cms/24 (26) (28) (30) inch chest.

Materials:

Knitmaster Chunky. Colours shown Midnight and Geranium.

Sweater

Col 1 - 260 (290) (320) (350) grms

Cardigan

Col 1 - 270 (300) (330) (360) grms

Crew Neck Cardigan - 8 (8) (9) (9) buttons.

V-Neck Cardigan - 6 (6) (7) (7) buttons.

Tensions:

Stockinet - 15 sts and 22 rows to 10 cms. TD at approx. 6 (MT)

Knit 1 Purl 1 Rib - 27 rows to 10 cms. TD at approx. MT-5

Pattern Note:

Stockinet

Row 54 (66) (70) (78).

Shape Top

Cast off 3 sts beg next 2 (4) (4) (4) rows.

1st Size Only

Cast off 2 sts beg next 4 rows.

All Sizes

Dec 1 st at both ends of the next and ev foll alt row 3 (4) (5) (5) times in all, knit 1 row. Cast off 2 sts beg next 2 (4) (4) (6) rows, 3 sts beg next 2 rows and 4 sts beg next 2 rows. Cast off rem 8 (8) (9) (9) sts.

CREW NECK SWEATER

FRONT

Knit as for back to*. Knit to Row 70 (76) (84) (88). Carr at right.

Shape Neck

Using a length of col 1, cast off centre 10 sts. Hold Ns at left.

Knit Right Part as Follows:-

Knit 1 row. Cast off 2 sts beg next row, knit 1 row. Dec 1 st at neck edge on the next and ev foll 3rd row 3 times in all. Knit to Row 82 (88) (96) (102).

Carr at right.

Shape Shoulder

Cast off 5 (6) (7) (7) sts beg next row, knit 1 row. Cast off rem 5 (5) (6) (7) sts. Take carr to left. Bring Ns back to WP. Knit left part as for right part but read left for right.

NECKBAND

Push 60 (60) (60) (63) Ns to WP. Cast on as given in additional notes for Knit 1 Purl 1 Rib. RC 000. MT-5, knit 15 rows. Drop the 3rd and ev foll alt st and pick up as for Knit 1 Purl 1 Rib. Knit 1 row MT. Cast off with waste yarn.

TO MAKE UP

Pin out to size and steam carefully. Join shoulder seams. Set in sleeves. Join side and sleeve seams. Backstitch neckband into pos and join centre back neck seam. Fold in half and catch down on the inside. Give final light steam.

V-NECK SWEATER

FRONT

Knit as for Back to**. Knit 46 (50) (56) (60) rows. Carr at right.

Shape Neck

Hold Ns at left.

Knit Right Part as Follows:-

Dec 1 st at left edge on the next row, knit 1 row. RC 48 (52) (58) (62). Carr at right.

Shape Armhole

Cast off 2 sts beg next row, knit 1 row. Dec 1 st at neck edge on the next and ev foll 4th row 9 times in all, AT THE SAME TIME dec 1 st at armhole edge on the next and ev foll 4th row 3 (4) (4) (5) times in all. Knit to Row 82 (88) (96) (102). Carr at right.

Shape Shoulder

Cast off 5 (6) (7) (7) sts beg next row, knit 1 row. Cast off rem 5 (5) (6) (7) sts. Take carr to left. Bring Ns back to WP. Knit left part as for right part but read left for right and vice versa.

NECKBAND

Push 78 (81) (84) (87) Ns to WP. Cast on as given in additional notes for Knit 1 Purl 1 Rib. RC 000. MT-5, knit 9 rows. Drop the 3rd and ev foll alt st and pick up as for Knit 1 Purl 1 Rib. Knit 1 row MT. Cast off with waste yarn.

TO MAKE UP

Pin out to size and steam carefully. Join shoulder seams. Set in sleeves. Join side and sleeve seams. Backstitch neckband into pos overlapping at centre front. Neaten front edge. Give final light steam.

CREW NECK CARDIGAN

RIGHT FRONT

Push 22 (24) (26) (27) Ns to WP. Cast on as given in additional notes for Knit 1 Purl 1 Rib. RC 000. MT-5, knit 10 rows. Drop the 3rd and ev foll alt st and pick up as for Knit 1 Purl 1 Rib. Cast off with

Continued on page 23





6

6 ARAN CREW NECK SWEATER & CARDIGAN



These beautiful Aran style sweaters show just how far machine knitting has come in recent years. Even if you don't intend knitting these designs just yet, knit a sample piece of the fabric following the larger chart, just to familiarise yourself with the techniques involved. You may even like to use this fabric to knit a beautiful Aran style sweater for yourself.

BACK

Push 23 (25) (26) (28) Ns at left and right of centre O to WP. 46 (50) (52) (56) Ns altog. Cast on as given in additional notes for Knit 1 Purl 1 Rib. RC 000. MT-6, knit 14 rows. Drop the 3rd and ev foll alt st and pick up as for Knit 1 Purl 1 Rib. Using waste yarn knit several rows and release from machine. Push 26 (28) (30) (32) Ns at left and right of centre O to WP. 52 (56) (60) (64) Ns altog. Carr at right. Pick up sts from below waste yarn and place onto Ns in WP increasing evenly. RC 000. MT. Continue in pattern. Knit 52 (58) (62) (68) rows. Mark both ends with waste yarn*. Knit 38 (42) (44) (46) rows. RC 90 (100) (106) (114). Carr at right.

Shape Back Neck

Note pos in pattern. Using a length of col 1, cast off centre 16 sts. Hold Ns at left.

Knit Right Part as Follows:-

Knit 1 row. Cast off 3 sts beg next row. Cast off rem 15 (17) (19) (21) sts. Take carr to left. Bring Ns back to WP. Keeping pattern correct, knit left part as for right part.

SLEEVES

Push 13 (13) (14) (14) Ns at left and right of centre O to WP. 26 (26) (28) (28) Ns altog. Cast on as given in additional notes for Knit 1 Purl 1 Rib. RC 000. MT-6, knit 14 rows. Drop the 3rd and ev foll alt st and pick up as for Knit 1 Purl 1 Rib. Using waste yarn knit several rows and release from machine. Push 16 (16) (17) (17) Ns at left and right of centre O to WP. 32 (32) (34) (34) Ns altog. Pick up

For Knitmaster 9mm Chunky Machines.

Sizes:

To fit 61 (66) (71) (76) cms/24 (26) (28) (30) inch chest.

Materials:

Knitmaster Chunky.
Sweater
Col 1 (Aran) - 270 (300) (330) (360) grms
Cardigan
Col 1 (Aran) - 280 (310) (340) (370) grms
9 (9) (10) (10) buttons.

Tensions:

Stockinet - 15.5 sts and 24 rows to 10 cms. TD at approx. 7 (MT)
Knit 1 Purl 1 Rib - 27 rows to 10 cms. TD at approx. MT-6

Pattern Note:

Cable and garter stitch - follow chart.

sts from below waste yarn and place onto Ns increasingly evenly. RC 000. MT. Continue in pattern. Knit 1 (1) (0) (1) row. Inc 1 st both ends next and ev foll 6th row 10 (12) (13) (14) times in all. 52 (56) (60) (62) sts. Knit 4 (2) (1) (4) rows. RC 60 (70) (74) (84). Mark centre with waste yarn. Cast off.

SWEATER

FRONT

Knit as for Back to*. Knit 26 (30) (32) (32) rows. RC 78 (88) (94) (100). Carr at right. Shape Neck

Note pos in pattern. Using a length of col 1, cast off centre 10 sts. Hold Ns at left.

Knit Right Part as Follows:-

Knit 1 row. Cast off 2 sts beg next row, knit 1 row. Dec 1 st at neck edge on the next and ev foll alt row 4 times in all, knit 4 (4) (4) (6) rows. Cast off rem 15 (17) (19) (21) sts. Take carr to left. Bring Ns back to WP. Keeping pattern correct, knit left part as for right part.

CARDIGAN

RIGHT FRONT

Push 23 (25) (26) (28) Ns at right of centre O to WP. Cast on as given in additional notes for Knit 1 Purl 1 Rib. RC 000. MT-6, knit 14 rows. Drop the 3rd and ev foll alt st and pick up as for Knit 1 Purl 1 Rib. Using waste yarn knit several rows and release from machine. Push 26 (28) (30) (32) Ns at right of centre O to WP. Carr at right. Pick up sts from below waste yarn and place onto Ns in WP increasing evenly. RC 000. MT. Continue in pattern. Knit 52 (58) (62) (68) rows. Mark right edge with waste yarn. Knit 25 (29) (31) (31) rows. RC 77 (87) (93) (99). Carr at left.

Shape Neck

Cast off 5 sts beg next row, knit 1 row. Cast off 2 sts beg next row, knit 1 row. Dec 1 st beg next and ev foll alt row 4 times in all, knit 4 (4) (4) (6) rows. Cast off rem 15 (17) (19) (21) sts.

LEFT FRONT

Knit as for Right Front but read left for right and vice versa throughout.

SWEATER & CARDIGAN

NECKBAND

Push 62 (62) (62) (65) Ns to WP. Cast on as given in additional notes for Knit 1 Purl 1 Rib. RC 000. MT-6, knit 15 rows. Drop the 3rd and ev foll alt st and pick up as for Knit 1 Purl 1 Rib. MT, knit 1 row. Cast off with waste yarn.

CARDIGAN

BUTTONHOLE BAND

Push 62 (67) (72) (75) Ns to WP. Cast on as given in additional notes for Knit 1 Purl 1 Rib. RC 000. MT-6, knit 5 rows. Drop the 3rd and ev foll alt st and pick up as for Knit 1 Purl 1 Rib. Make 9 (9) (10) (10) evenly spaced buttonholes over 1 N. Knit 4 rows. Drop the 3rd and ev foll alt st and pick up as for Knit 1 Purl 1 Rib. MT, knit 1 row. Cast off with waste yarn. Knit button band as for buttonhole band but omit buttonholes.

SWEATER

TO MAKE UP

Pin out to size and steam carefully. Join shoulder seams. Set in sleeves between marked points. Join side and sleeve seams. Backstitch neckband into pos and join centre back neck seam. Fold in half and catch down on the inside. Give final light steam.

CARDIGAN

TO MAKE UP

Pin out to size and steam carefully. Join shoulder seams. Set in sleeves between marked points. Join side and sleeve seams. Backstitch neckband into pos, fold in half and catch down on the inside. Backstitch front bands into pos. Sew on buttons to correspond with buttonholes. Give final light steam.

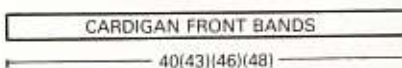
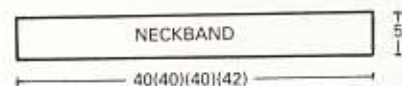

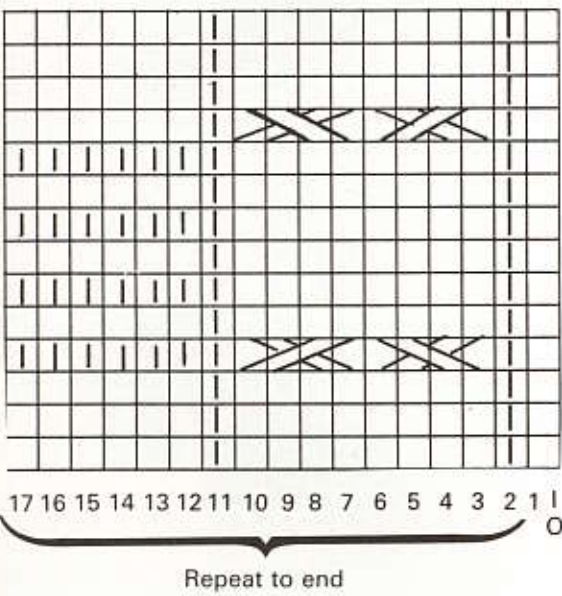
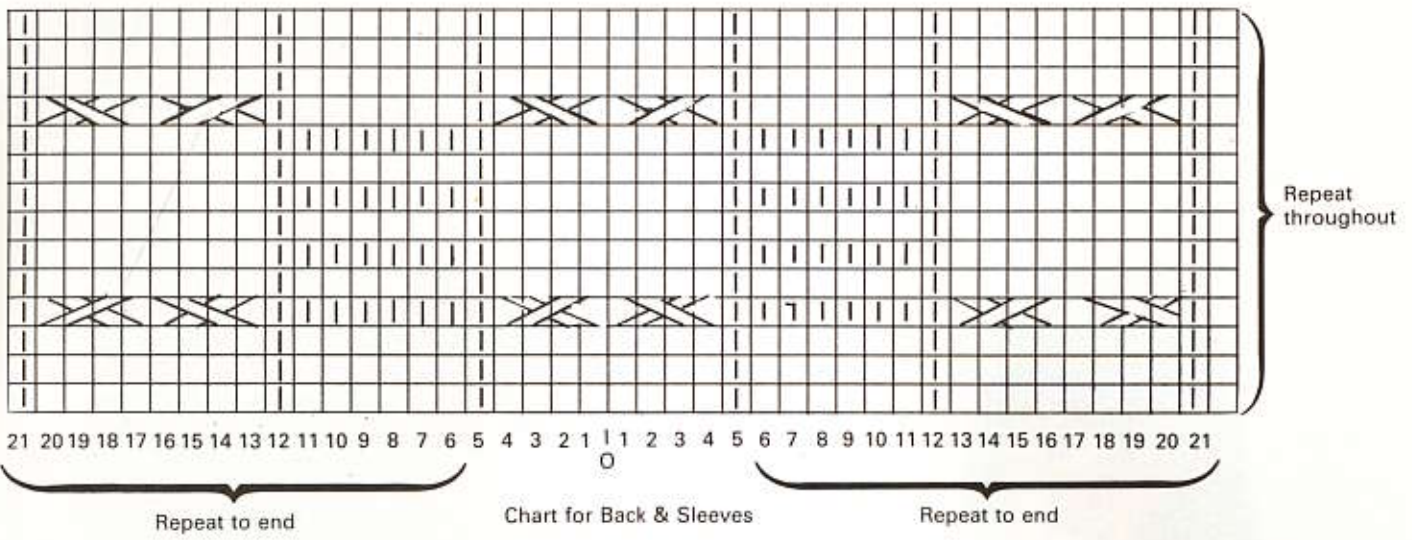

- | = drop and reform as for ribbing using a latch tool
- X = cross sts at left over sts at right
- X = cross sts at right over sts at left

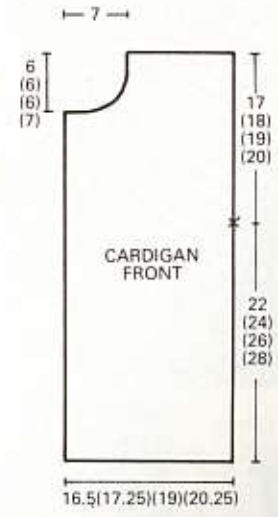
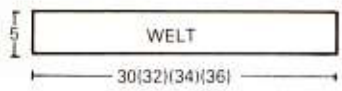
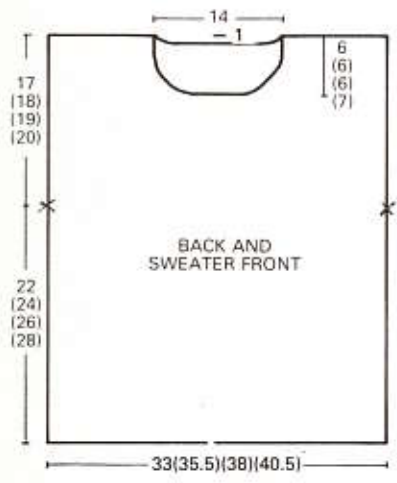
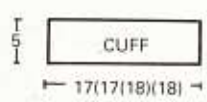
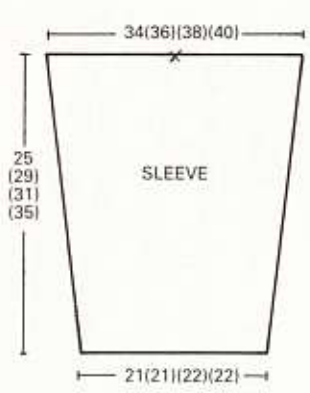

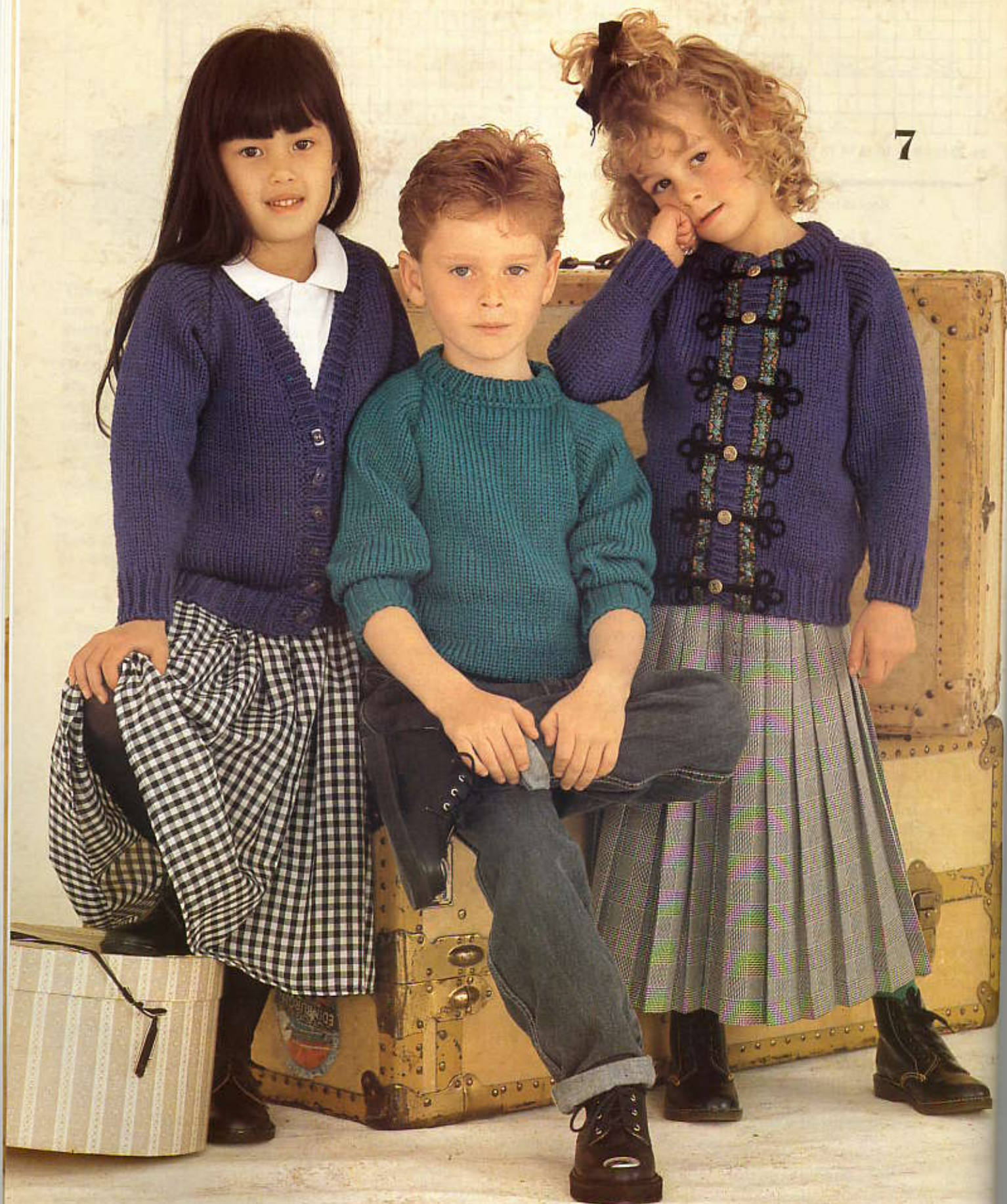

7 RAGLAN CREW & V-NECK SWEATER & CARDIGAN



For Knitmaster 9mm Chunky Machines.

Sizes:

To fit 61 (66) (71) (76) cms/24 (26) (28) (30) inch chest.

Materials:

Knitmaster Chunky.
Colours shown Serpentine and Bluebell.
Sweater
Col 1 – 260 (290) (320) (350) grms
Cardigan
Col 1 – 270 (300) (330) (360) grms
Crew Neck Cardigan – 8 (8) (9) (9) buttons.
V-Neck Cardigan – 6 (6) (7) (7) buttons.

V-Neck Cardigan – 6 (6) (7) (7) buttons.

Tensions:

Stockinet – 15 sts and 22 rows to 10 cms. TD at approx. 6 (MT)
Knit 1 Purl 1 Rib – 27 rows to 10 cms. TD at approx. MT-5

Pattern Note:

Stockinet

Classic raglan styles are always popular and this pattern includes 4 basic versions of this style — a v-neck sweater, a v-neck cardigan, crew neck sweater and crew neck cardigan. We added an extra touch of decoration to the crew neck cardigan in the form of some braid and frogging. Use this idea or your own version of it to decorate any plain cardigan.

BACK

Push 45 (48) (51) (54) Ns to WP. Cast on as given in additional notes for Knit 1 Purl 1 Rib. RC 000. MT-5, knit 10 rows. Drop the 3rd and ev foll alt st and pick up as for Knit 1 Purl 1 Rib. Using waste yarn, knit 8 rows and release from machine. Push 25 (27) (29) (31) Ns at left and right of centre O to WP. 50 (54) (58) (62) Ns altog. With wrong side facing, pick up sts from below waste yarn and place onto Ns increasing evenly. RC 000. MT. Using col 1, knit 48 (52) (58) (62) rows. Carr at right**.

Shape Raglan Armholes

Cast off 3 sts beg next 2 rows***.

1st & 2nd Sizes Only

Dec 1 st both ends of next and foll alt row, knit 2 rows. Rept the last 5 rows 6 more times.

2nd Size Only

Dec 1 st both ends next and foll alt row.

3rd Size Only

Dec 1 st both ends next and ev foll alt row 4 times in all, knit 2 rows. Rept the last 9 rows from *to* 3 more times. Dec 1 st both ends of next and foll alt row.

4th Size Only

Dec 1 st both ends of next and ev foll alt row 20 times in all.

All Sizes

16 sts. Knit 1 (0) (1) (3) rows. RC 86 (92) (100) (106). Cast off.

LEFT SLEEVE

Push 13 (13) (14) (14) Ns at left and right of centre O to WP. 26 (26) (28) (28) Ns altog. Cast on as given in additional

notes for Knit 1 Purl 1 Rib. RC 000. MT-5, knit 10 rows. Drop the 3rd and ev foll alt st and pick up as for Knit 1 Purl 1 Rib. RC 000. MT. Knit 2 (2) (2) (4) rows. Inc 1 st both ends of the next and ev foll 4th row 15 (17) (18) (19) times in all. 56 (60) (64) (66) sts. Knit to Row 60 (68) (72) (82). (Knit 1 row extra for Right Sleeve Only). Carr at right.

Shape Raglan Top

Cast off 3 sts beg next 2 rows. Dec 1 st both ends of next 20 (22) (24) (25) rows, knit 0 (0) (0) (1) row. 10 sts. Carr at right. Cast off 8 sts beg next row, knit 1 row. Cast off rem 2 sts.

RIGHT SLEEVE

Knit as for Left Sleeve but note alteration in number of rows worked and read left for right.

CREW NECK SWEATER

FRONT

Knit as for Back to ***.

1st & 2nd Sizes Only

Dec 1 st both ends of next and foll alt row, knit 2 rows. Rept the last 5 rows 4 more times.

2nd Size Only

Dec 1 st both ends of next row, knit 1 row.

3rd Size Only

Dec 1 st both ends of next and ev foll alt row 4 times in all, knit 2 rows. Rept the last 9 rows from *to* twice more. Dec 1 st both ends of next row, knit 1 row.

4th Size Only

Dec 1 st both ends of next and ev foll alt row 15 times in all.

All Sizes

24 (26) (26) (26) sts. RC 75 (81) (89) (93). Carr at left.

Shape Neck

Using a length of col 1, cast off centre 6 sts. Hold Ns at right.

Knit Left Part as Follows:—

1st Sizes Only

Dec 1 st beg next row, cast off 2 sts beg next row. Rept the last 2 rows once

more. Knit 1 row. Dec 1 st both ends next row. Fasten off rem st.

2nd & 3rd Sizes Only

Dec 1 st beg next row, cast off 2 sts beg next row. Rept the last 2 rows twice more. Fasten off rem st.

4th Size Only

Knit 1 row. Cast off 2 sts at beg and dec 1 st at raglan edge on the next row, knit 1 row. Dec 1 st both ends of the next and ev foll alt row 3 times in all. Fasten off rem st.

All Sizes

Take carr to right. Bring Ns back to WP. Knit right part as for left part.

NECKBAND

Push 60 (60) (60) (63) Ns to WP. Cast on as given in additional notes for Knit 1 Purl 1 Rib. RC 000. MT-5, knit 15 rows. Drop the 3rd and ev foll alt st and pick up as for Knit 1 Purl 1 Rib. Knit 1 row MT. Cast off with waste yarn.

TO MAKE UP

Pin out to size and steam carefully. Join raglan, side and sleeve seams. Backstitch neckband into pos and join centre back neck seam. Fold in half and catch down on the inside. Give final light steam.

V-NECK SWEATER

FRONT

Knit as for Back to**.

Shape Neck and Raglan Armhole Hold Ns at left.

Knit Right Part as Follows:—

Dec 1 st at neck edge on the next and ev foll 4th (4th) (4th) (5th) row 8 times in all, AT THE SAME TIME cast off 3 sts beg next row, knit 1 row.

1st & 2nd Sizes Only

Dec 1 st at raglan edge on the next and foll alt row, knit 2 rows. Rept the last 5 rows 5 more times.

1st Size Only

Dec 1 st at raglan edge on the next row.

2nd Size Only

Dec 1 st at raglan edge on the next and foll alt row.

3rd Size Only

Dec 1 st at raglan edge on the next and ev foll alt row 4 times in all, knit 2 rows. Rept the last 9 rows from *to* twice more. Dec 1 st at raglan edge on the next and ev foll alt row 4 times in all, knit 1 row.

4th Size Only

Dec 1 st at raglan edge on the next and ev foll alt row 19 times in all.

All Sizes

RC 81 (87) (95) (101). Cast off rem 1 (2) (2) (1) sts. Take carr to left. Bring Ns back to WP. Knit left part as for right part.

NECKBAND

Push 78 (81) (84) (87) Ns to WP. Cast on as given in additional notes for Knit 1 Purl 1 Rib. RC 000. MT-5, knit 9 rows. Drop the 3rd and ev foll alt st and pick up as for Knit 1 Purl 1 Rib. Knit 1 row MT. Cast off with waste yarn.

TO MAKE UP

Pin out to size and steam carefully. Join raglan, side and sleeve seams. Backstitch neckband into pos overlapping at centre front. Neaten front edge. Give final light steam.

CREW NECK CARDIGAN

RIGHT FRONT

Push 22 (24) (26) (27) Ns to WP. Cast on as given in additional notes for Knit 1 Purl 1 Rib. RC 000. MT-5, knit 10 rows. Drop the 3rd and ev foll alt st and pick up as for Knit 1 Purl 1 Rib. Using waste yarn knit 8 rows and release from machine. Push 25 (27) (29) (31) Ns at right of centre O to WP. With wrong side facing, pick up sts from below waste yarn and place onto Ns increasing evenly. RC 000. MT. Using col 1, knit 48 (52) (58) (62) rows. Carr at right*.

Shape Raglan Armhole

Cast off 3 sts beg next row, knit 1 row.

1st & 2nd Sizes Only

Dec 1 st at raglan edge on the next and foll alt row, knit 2 rows. Rept the last 5 rows 4 more times.

2nd Size Only

Dec 1 st at raglan edge on the next row, knit 1 row.

3rd Size Only

Dec 1 st at raglan edge on the next and ev foll alt row 4 times in all, knit 2 rows. Rept the last 9 rows from *to* twice more. Dec 1 st at raglan edge on the next row, knit 1 row.

4th Size Only

Dec 1 st at raglan edge on the next and ev foll alt row 15 times in all.

All Sizes

12 (13) (13) (13) sts. RC 75 (81) (89) (93). Carr at left.

Shape Neck

1st Size Only

Cast off 3 sts at beg and dec 1 st at raglan edge on the next row, dec 1 st beg next row, cast off 2 sts beg next row, dec 1 st beg next row, cast off 2 sts beg next row, knit 1 row. Dec 1 st at neck edge on the next row.

2nd & 3rd Sizes Only

Cast off 3 sts beg next row, dec 1 st beg next row, cast off 2 sts beg next row,

dec 1 st beg next row, cast off 2 sts beg next row, dec 1 st beg next row, cast off 2 sts beg next row.

4th Size Only

Cast off 3 sts beg next row, knit 1 row. Cast off 2 sts at beg and dec 1 st at raglan edge on the next row, knit 1 row. Dec 1 st both ends next and ev foll alt row 3 times in all.

All Sizes

Fasten off rem st.

LEFT FRONT

Knit as for Right Front but read left for right and vice versa throughout.

NECKBAND

Push 60 (60) (60) (63) Ns to WP. Cast on as given in additional notes for Knit 1 Purl 1 Rib. RC 000. MT-5, knit 18 rows. Drop the 3rd and ev foll alt st and pick up as for Knit 1 Purl 1 Rib. Knit 1 row MT. Cast off with waste yarn.

BUTTONHOLE BAND

Push 62 (66) (71) (74) Ns to WP. Cast on as given in additional notes for Knit 1 Purl 1 Rib. RC 000. MT-5, knit 5 rows. Drop the 3rd and ev foll alt st and pick up as for Knit 1 Purl 1 Rib. Make 8 (8) (9) (9) evenly spaced buttonholes over 1 N. Knit 4 rows. Drop the 3rd and ev foll alt st and pick up as for Knit 1 Purl 1 Rib. Knit 1 row MT. Cast off with waste yarn.

BUTTON BAND

Knit as for Buttonhole Band but omit buttonholes.

TO MAKE UP

Pin out to size and steam carefully. Join raglan, side and sleeve seams. Backstitch neckband into pos, fold in half and catch down on the inside. Backstitch front bands into pos. Sew on buttons to correspond with buttonholes. Give final light steam.

V-NECK CARDIGAN

RIGHT FRONT

Knit as for Right Front Crew Neck Cardigan*.

Shape Front Edge and Raglan Armhole

Dec 1 st at left edge on the next and ev foll 4th (4th) (4th) (5th) row 8 times in all, AT THE SAME TIME cast off 3 sts beg next row, knit 1 row.

1st & 2nd Sizes Only

Dec 1 st at raglan edge on the next and foll alt row, knit 2 rows. Rept the last 5 rows 5 more times.

1st Size Only

Dec 1 st at raglan edge on the next row.

2nd Size Only

Dec 1 st at raglan edge on the next and foll alt row.

3rd Size Only

Dec 1 st at raglan edge on the next and ev foll alt row 4 times in all, knit 2 rows. Rept the last 9 rows from *to* twice more. Dec 1 st at raglan edge on the next and ev foll alt row 4 times in all, knit 1 row.

4th Size Only

Dec 1 st at raglan edge on the next and ev foll alt row 19 times in all.

All Sizes

RC 81 (87) (95) (101). Cast off rem 1 (2) (2) (1) sts.

LEFT FRONT

Knit as for Right Front but read left for right and vice versa.

BACK NECKBAND

Push 24 Ns to WP. Cast on as given in additional notes for Knit 1 Purl 1 Rib. RC 000. MT-5, knit 9 rows. Drop the 3rd and ev foll alt st and pick up as for Knit 1 Purl 1 Rib. Knit 1 row MT. Cast off with waste yarn.

BUTTONHOLE BAND

Push 69 (74) (78) (83) Ns to WP. Cast on as given in additional notes for Knit 1 Purl 1 Rib. RC 000. MT-5, knit 5 rows. Drop the 3rd and ev foll alt st and pick up as for Knit 1 Purl 1 Rib. Make 6 (6) (7) (7) evenly spaced buttonholes over 1 N on 39 (42) (45) (48) sts at right. Knit 4 rows. Drop the 3rd and ev foll alt st and pick up as for Knit 1 Purl 1 Rib. Knit 1 row MT. Cast off with waste yarn.

BUTTON BAND

Knit as for Buttonhole Band but omit buttonholes.

TO MAKE UP

Pin out to size and steam carefully. Join raglan, side and sleeve seams. Backstitch back neckband into pos. Backstitch front bands into pos and join seams. Sew on buttons to correspond with buttonholes. Give final light steam.

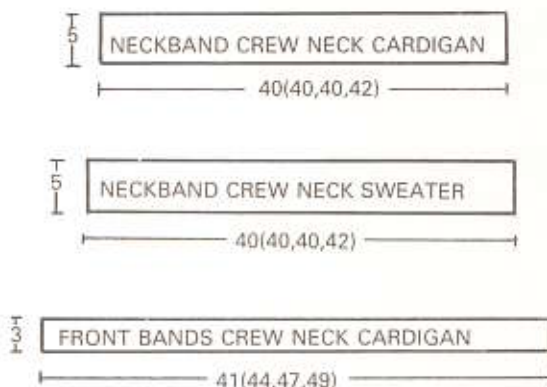

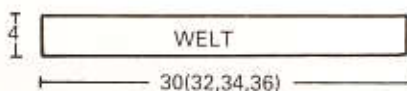
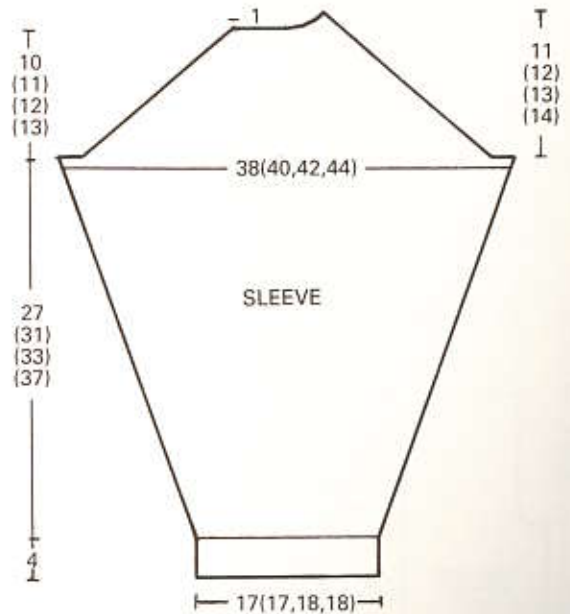
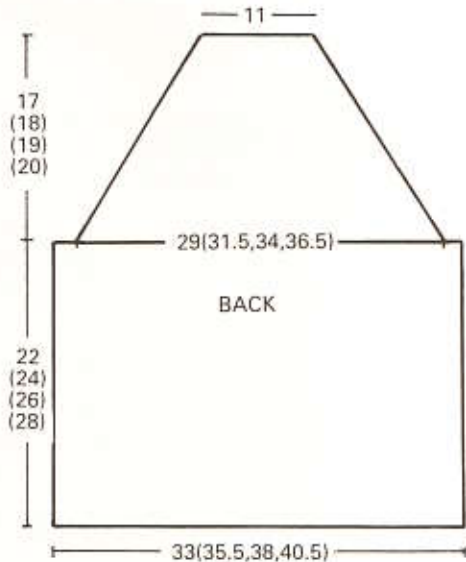
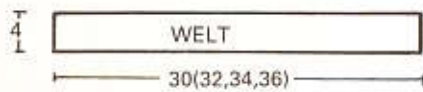
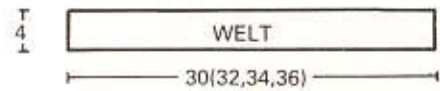
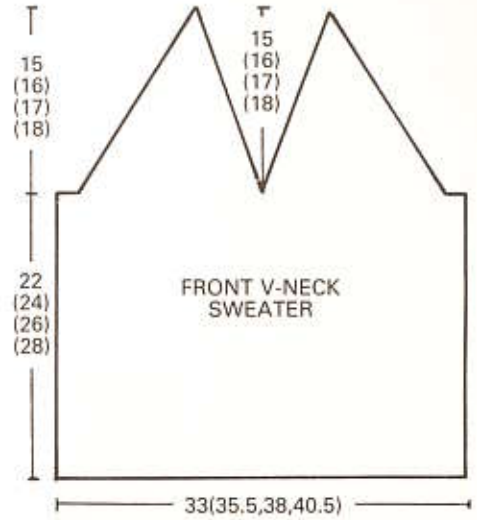
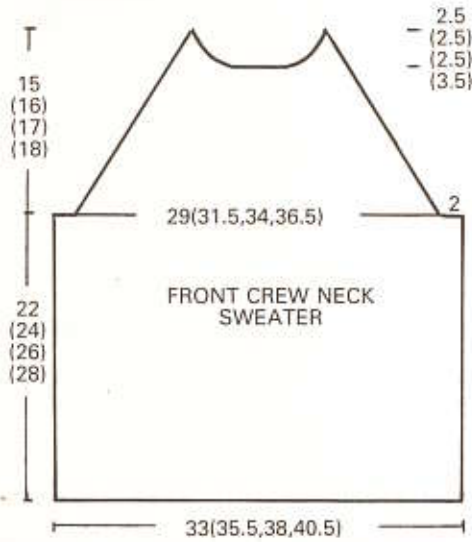
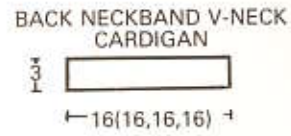
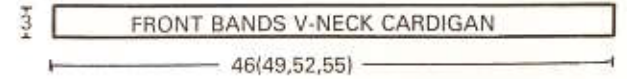
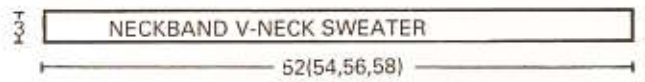
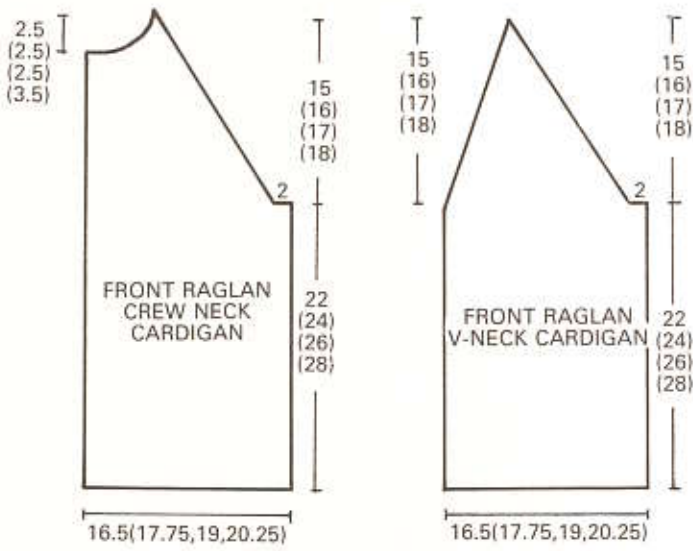

Continued on page 43

PATTERN 3

Continued from page 9

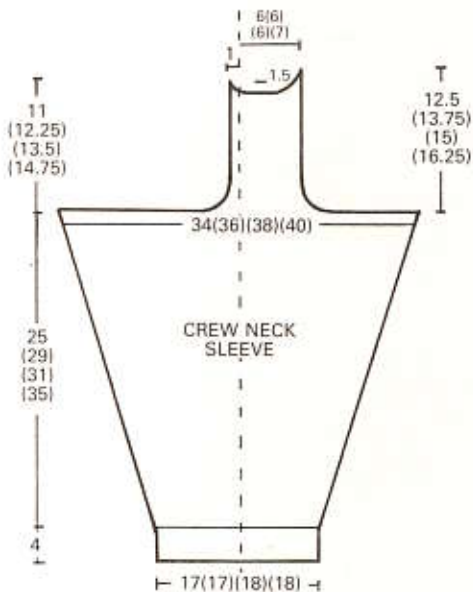
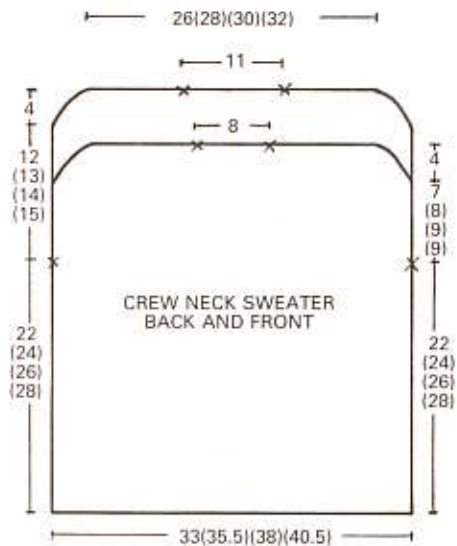
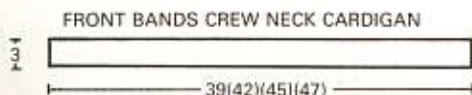
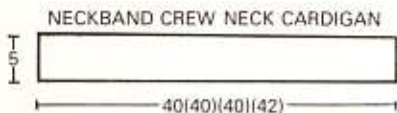
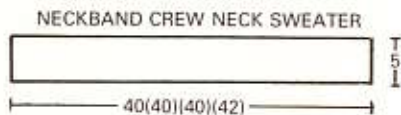
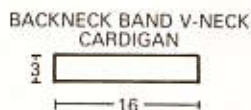
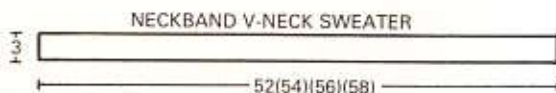
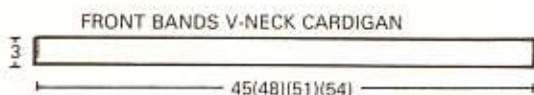
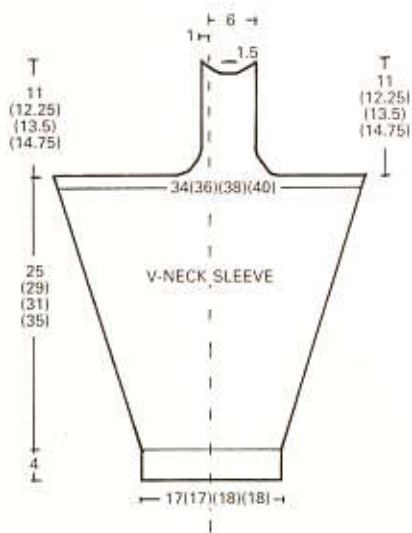

13 (14) (15) (16)

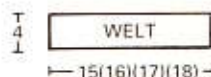
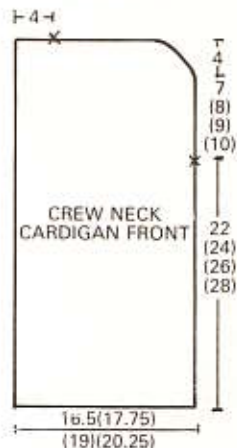

PATTERN 5

Continued from page 13

waste yarn. Push 25 (27) (29) (31) Ns to WP. With carr at right pick up sts from below waste yarn and place onto Ns increasing evenly. RC 000. MT. Using col 1*, knit 48 (52) (58) (62) rows. Carr at right.

Shape Armhole

Cast off 2 sts beg next row, knit 1 row. Dec 1 st at armhole edge on the next and ev foll 4th row 3 (4) (4) (5) times in all. Knit to Row 71 (77) (85) (89). Carr at left.

Shape Neck

Cast off 5 sts beg next row, knit 1 row. Cast off 2 sts beg next row, knit 1 row. Dec 1 st at neck edge on the next and ev foll 3rd row 3 times in all, knit 0 (0) (0) (2) rows. RC 82 (88) (96) (102). Carr at right.

Shape Shoulder

Cast off 5 (6) (7) (7) sts beg next row, knit 1 row. Cast off rem 5 (5) (6) (7) sts.

LEFT FRONT

Knit as for Right Front but read left for right and vice versa.

NECKBAND

Push 60 (60) (60) (63) Ns to WP. Cast on as given in additional notes for Knit 1 Purl 1 Rib. RC 000. MT-5, knit 18 rows. Drop the 3rd and ev foll alt st and pick up as for Knit 1 Purl 1 Rib. Knit 1 row MT. Cast off with waste yarn.

BUTTONHOLE BAND

Push 58 (63) (68) (71) Ns to WP. Cast on as given in additional notes for Knit 1 Purl 1 Rib. RC 000. MT-5, knit 5 rows. Drop the 3rd and ev foll alt st and pick up as given for Knit 1 Purl 1 Rib. Make 8 (8) (9) (9) evenly spaced buttonholes over 1 N. Knit 4 rows. Drop the 3rd and ev foll alt st and pick up as for Knit 1 Purl 1 Rib. Knit 1 row MT. Cast off with waste yarn.

BUTTON BAND

Knit as for Buttonhole Band but omit buttonholes.

TO MAKE UP

Pin out to size and steam carefully. Join shoulder seams. Set in sleeves. Join side and sleeve seams. Backstitch neckband into pos. Fold in half and catch down on the inside. Backstitch front band into pos. Sew on buttons to correspond. Give final light steam.

V-NECK CARDIGAN

RIGHT FRONT

Knit as for Right Front of Crew Neck Cardigan to*. Knit 46 (50) (56) (60) rows. Carr at right.

Shape Front Edge

Dec 1 st at left edge on the next row, knit 1 row. RC 48 (50) (58) (62). Carr at right.

Shape Armhole

Cast off 2 sts beg next row, knit 1 row. Dec 1 st at neck edge on the next and ev foll 4th row 9 times in all, AT THE SAME TIME dec 1 st at armhole edge on the

next an ev foll 4th row 3 (4) (4) (5) times in all. Knit to Row 82 (88) (96) (102). Carr at right.

Shape Shoulder

Cast off 5 (6) (7) (7) sts beg next row, knit 1 row. Cast off rem 5 (5) (6) (7) sts.

LEFT FRONT

Knit as for Right Front but read left for right and vice versa.

BACK NECKBAND

Push 24 Ns to WP. Cast on as given in additional notes for Knit 1 Purl 1 Rib. RC 000. MT-5, knit 9 rows. Drop the 3rd and ev foll alt st and pick up as for Knit 1 Purl 1 Rib. Knit 1 row MT. Cast off with waste yarn.

BUTTONHOLE BAND

Push 67 (71) (76) (80) Ns to WP. Cast on as given in additional notes for Knit 1

Purl 1 Rib. RC 000. MT-5, knit 5 rows. Drop the 3rd and ev foll alt st and pick up as for Knit 1 Purl 1 Rib. Make 6 (6) (7) (7) evenly spaced buttonholes over 1 N on 38 (41) (44) (47) Ns at right. Knit 4 rows. Drop the 3rd and ev foll alt st and pick up as for Knit 1 Purl 1 Rib. Knit 1 row MT. Cast off with waste yarn.

BUTTON BAND

Knit as for Buttonhole Band but omit buttonholes.

TO MAKE UP

Pin out to size and steam carefully. Set in sleeves. Join side and sleeve seams. Backstitch neckband into pos. Backstitch front bands into pos and join seams. Sew on buttons to correspond with buttonholes. Give final light steam.

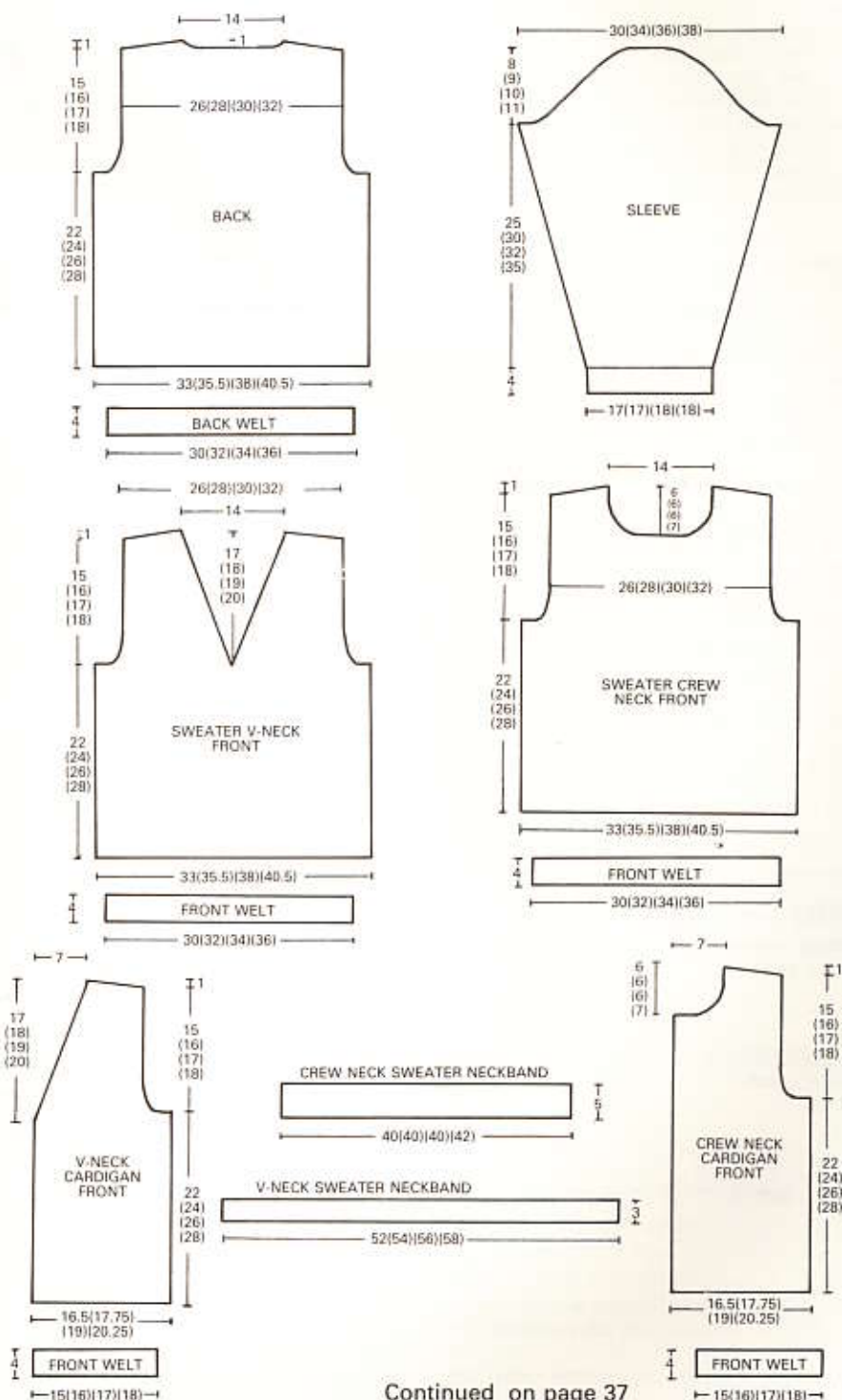

Continued on page 37

Additional Notes

Knit 1 Purl 1 Rib

Push required number of needles to Working Position.

Push the 3rd and every following alternate needle back to Non Working Position.

Cast on and knit several rows with waste yarn.

Set Tension Dial to number given in pattern for Knit 1 Purl 1 Rib. Using Main Yarn, knit 4 rows.

Insert transfer tool into the end loop of the first row of main knitting.

Lift that loop and put into the end needle. Bring the alternate needles forward to Working Position.

Knit the number of rows stated in the pattern.

Drop the 3rd and every following alternate stitch back to the waste yarn.

Using the latch tool, reform the dropped stitches in the following way.

Insert the latch tool under the loop of the first row of main knitting. Ignoring the next 3 bars, catch the yarn of the 5th row in the hook of the latch tool.

Pull the tool towards you until the first loop slips over the hook to form a new stitch.

Continue reforming stitches in this way until all the bars above have been knitted.

Replace the stitch onto the needle.

Repeat this procedure on alternate stitches until the rib is complete.

Missing 3 bars at the bottom each time gives this rib a nice firm edge.

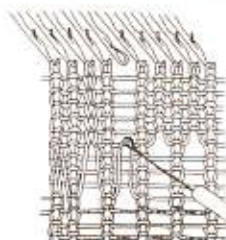
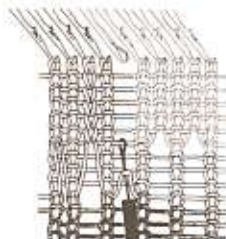
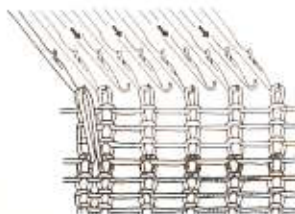
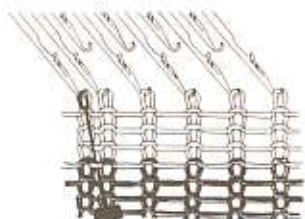

Increasing evenly across a row

1. Push up additional needles required for increase to WP and place the stitches of the last row of main knitting onto the needles in WP omitting a needle at appropriate intervals.

Remove the waste knitting.

2. Pick up the stitches of the previous row, next to the empty needle, and place them onto the empty needles.

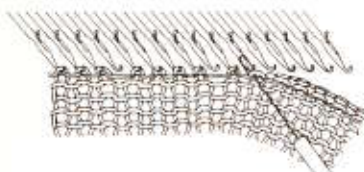

Swiss Darning

1. Bring needle up through the base of chosen stitch.

2. Take it behind the base of stitch above chosen stitch.

3. Take needle back through base of chosen stitch.

4. Pull thread up to a suitable tension so that new stitch fits snugly over the previous one.

Repeat this to form any pattern using any colour.

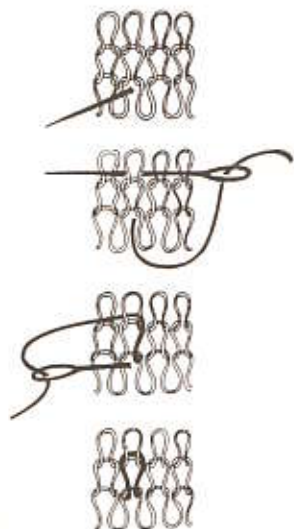

Main embroidery stitches

Daisy Stitch

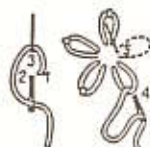

Cross Stitch



Stem Stitch



French Knot



Needle Positions

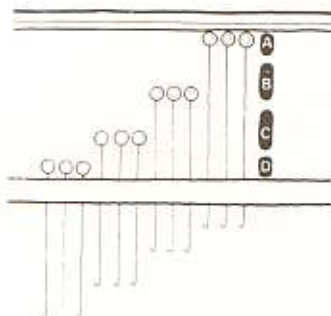

A ... non-working position

B ... working position

C ... upper working position

D ... holding position

Garner Stitch

Put the latch tool into the stitch below the one on the needle.

Drop the stitch by bringing the needle out to holding position then back to working position.

Catch the bar of the dropped stitch in the hook of the latch tool, pull through the stitch below and replace on the needle.

Repeat all along the row.

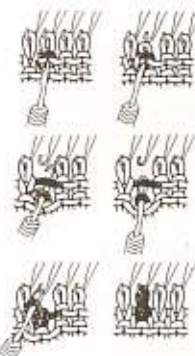

8 DROP SHOULDER CREW AND V-NECK SWEATER AND CARDIGAN



Our photo shows two versions of these drop shoulder designs — the v-neck cardigan and the crew neck sweater. However you'll also find instructions for v-neck sweaters and crew neck cardigans in this pattern. Use these lovely simple shapes as a basis for some of your own designs. Introduce a small motif using garter stitch or perhaps sew on a ready made badge motif.

BACK

Push 45 (48) (51) (54) Ns to WP. Cast on as given in additional notes for Knit 1 Purl 1 Rib. RC 000. MT-5, knit 10 rows. Drop the 3rd and ev foll alt st and pick up as for Knit 1 Purl 1 Rib. Cast off with waste yarn. Push 25 (27) (29) (31) Ns at left and right of centre O to WP. 50 (54) (58) (62) Ns altog. With carr at right pick up sts from below waste yarn and place onto Ns increasing evenly. RC 000. MT. Using col 1, knit 48 (52) (58) (62) rows. Mark both ends with waste yarn*. Knit 36 (38) (40) (42) rows. RC 84 (90) (98) (104). Carr at right.

Shape Back Neck

Using a length of col 1, cast off centre 14 sts. Hold Ns at left.

Knit Right Part as Follows:—

Knit 1 row. Cast off 3 sts beg next row. Cast off rem 15 (17) (19) (21) sts. Take carr to left. Bring Ns back to WP. Knit left part as for right part.

SLEEVES

Push 26 (26) (27) (27) Ns to WP. Cast on as given in additional notes for Knit 1 Purl 1 Rib. RC 000. MT-5, knit 10 rows. Drop the 3rd and ev foll alt st and pick up as for Knit 1 Purl 1 Rib. RC 000. MT. Knit 2 rows. Inc 1 st at both ends of the next and ev foll 4th row 7 (7) (7) (11) times in all, knit 3 rows. Inc 1 st at both ends of the next and ev foll 5th row 5 (7) (8) (6) times in all. 50 (54) (57) (61) sts. Knit to Row 55 (63) (68) (77). Mark centre with waste yarn. Cast off.

For Knitmaster 9mm Chunky Machines.

Sizes:

To fit 61 (66) (71) (76) cms/24 (26) (28) (30) inch chest.

Materials:

Knitmaster Chunky. Colour shown Aran.

Sweater

Col 1 — 260 (290) (320) (350) grms

Cardigan

Col 1 — 270 (300) (330) (360) grms

Crew Neck Cardigan — 8 (8) (9) (9) buttons.

V-Neck Cardigan — 6 (6) (7) (7) buttons.

Tensions:

Stockinet — 15 sts and 22 rows to 10 cms. TD at approx. 6 (MT)

Knit 1 Purl 1 Rib — 27 rows to 10 cms. TD at approx. MT-5

Pattern Note:

Stockinet

CREW NECK SWEATER

FRONT

Knit as for Back to*. Knit 24 (26) (28) (28) rows. RC 72 (78) (86) (90). Carr at right.

Shape Neck

Using a length of col 1, cast off centre 10 sts. Hold Ns at left.

Knit Right Part as Follows:—

Knit 1 row. Cast off 2 sts at beg of the next row, knit 1 row. Dec 1 st at neck edge on the next and ev foll 3rd row 3 times in all, knit 4 (4) (4) (6) rows. Cast off rem 15 (17) (19) (21) sts. Take carr to left. Bring Ns back to WP. Knit left part as for right part.

NECKBAND

Push 60 (60) (60) (63) Ns to WP. Cast on as given in additional notes for Knit 1 Purl 1 Rib. RC 000. MT-5, knit 15 rows. Drop the 3rd and ev foll alt st and pick up as for Knit 1 Purl 1 Rib. Knit 1 row MT. Cast off with waste yarn.

TO MAKE UP

Pin out to size and steam carefully. Join shoulder seams. Set in sleeves between marked points. Join side and sleeve seams. Backstitch neckband into pos and join centre back neck seam. Fold in half and catch down on the inside. Give final light steam.

V-NECK SWEATER

FRONT

Knit as for Back to*

Shape Neck

Hold Ns at left.

Knit Right Part as Follows:—

Dec 1 st at neck edge on the next and ev foll 4th row 10 times in all, knit 1 (3) (5) (7) rows. Cast off rem 15 (17) (19) (21) sts. Take carr to left. Bring Ns back to WP. Knit left part as for right part.

NECKBAND

Push 78 (81) (84) (87) Ns to WP. Cast on as given in additional notes for Knit 1 Purl 1 Rib. RC 000. MT-5, knit 9 rows. Drop the 3rd and ev foll alt st and pick

up as for Knit 1 Purl 1 Rib. Knit 1 row MT. Cast off with waste yarn.

TO MAKE UP

Pin out to size and steam carefully. Join shoulder seams. Set in sleeves between marked points. Join side and sleeve seams. Backstitch neckband into pos overlapping at centre front. Neaten front edge. Give final light steam.

CREW NECK CARDIGAN

RIGHT FRONT

Push 22 (24) (26) (27) Ns to WP. Cast on as given in additional notes for Knit 1 Purl 1 Rib. RC 000. MT-5, knit 10 rows. Drop the 3rd and ev foll alt st and pick up as for Knit 1 Purl 1 Rib. Cast off with waste yarn. Push 25 (27) (29) (31) Ns to WP. With carr at left pick up sts from below waste yarn and place onto Ns increasing evenly. RC 000. MT. Using col 1, knit 48 (52) (58) (62) rows. Mark right edge with waste yarn*. Knit 24 (26) (28) (28) rows. RC 72 (78) (86) (90). Carr at left.

Shape Neck

Cast off 5 sts at beg of the next row, knit 1 row. Cast off 2 sts at beg of the next row, knit 1 row. Dec 1 st at neck edge on the next and ev foll 3rd rows 3 times in all, knit 3 (3) (3) (5) rows. Cast off rem 15 (17) (19) (21) sts.

LEFT FRONT

Knit as for Right Front but read right for left and vice versa.

NECKBAND

Push 60 (60) (60) (63) Ns to WP. Cast on as given in additional notes for Knit 1 Purl 1 Rib. RC 000. MT-5, knit 18 rows. Drop the 3rd and ev foll alt st and pick up as for Knit 1 Purl 1 Rib. Knit 1 row MT. Cast off with waste yarn.

BUTTONHOLE BAND

Push 60 (64) (69) (72) Ns to WP. Cast on as given in additional notes for Knit 1 Purl 1 Rib. RC 000. MT-5, knit 5 rows.

Drop the 3rd and ev foll alt st and pick up as for Knit 1 Purl 1 Rib. Make 8 (8) (9) (9) evenly spaced buttonholes over 1 N. Knit 4 rows. Drop the 3rd and ev foll alt st and pick up as for Knit 1 Purl 1 Rib. Knit 1 row MT. Cast off with waste yarn.

BUTTON BAND

Knit as for Buttonhole Band but omit buttonholes.

TO MAKE UP

Pin out to size and steam carefully. Join shoulder seams. Set in sleeves between marked points. Join side and sleeve seams. Backstitch neckband into pos. Fold in half and catch down on the inside. Backstitch front bands into pos. Sew on buttons to correspond with buttonholes. Give final light steam.

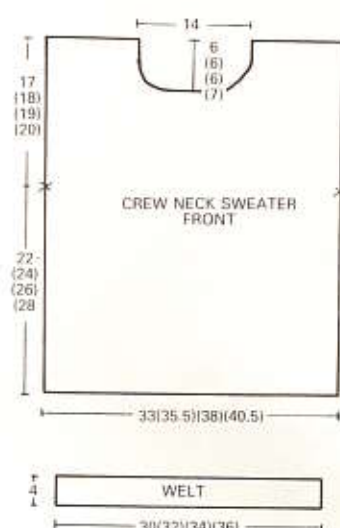
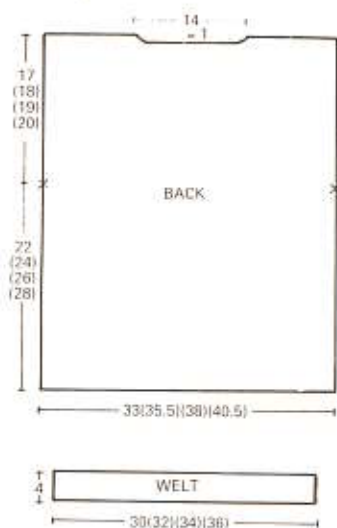

V-NECK CARDIGAN

RIGHT FRONT

Knit as for Right Front Crew Neck Cardigan to*.

Shape Front Edge

Dec 1 st at left edge on the next and ev foll 4th row 10 times in all, knit 1 (3) (5) (7) rows. Cast off rem 15 (17) (19) (21) sts.

LEFT FRONT

Knit as for Right Front but read right for left and vice versa.

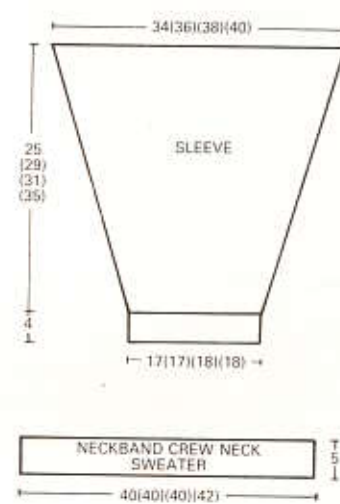
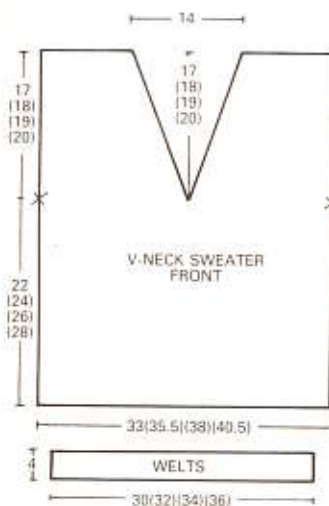

BACK NECKBAND

Push 24 Ns to WP. Cast on as given in additional notes for Knit 1 Purl 1 Rib. RC 000. MT-5, knit 9 rows. Drop the 3rd and ev foll alt st and pick up as for Knit 1 Purl 1 Rib. Knit 1 row MT. Cast off with waste yarn.

BUTTONHOLE BAND

Push 68 (72) (77) (81) Ns to WP. Cast on as given in additional notes for Knit 1 Purl 1 Rib. RC 000. MT-5, knit 5 rows. Drop the 3rd and ev foll alt st and pick up as for Knit 1 Purl 1 Rib. Make 6 (6) (7) (7) evenly spaced buttonholes over 1 N on 39 (42) (45) (48) Ns at right. Knit 4 rows. Drop the 3rd and ev foll alt st and pick up as for Knit 1 Purl 1 Rib. Knit 1 row MT. Cast off with waste yarn.

BUTTON BAND

Knit as for Buttonhole Band but omit buttonholes.

TO MAKE UP

Pin out to size and steam carefully. Join shoulder seams. Set in sleeves between marked points. Join side and sleeve seams. Backstitch neckband into pos. Backstitch front bands into pos and join seams. Sew on buttons to correspond with buttonholes. Give final light steam.

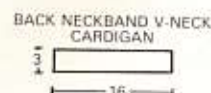
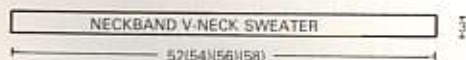
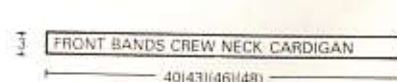
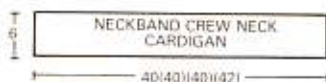
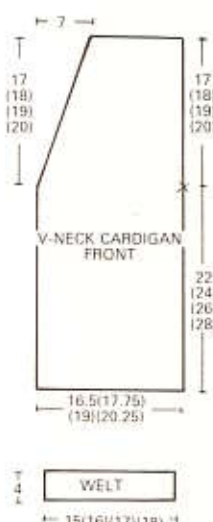
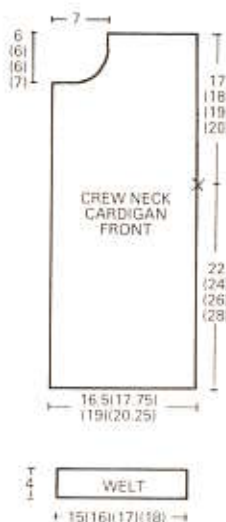



9 NAUTICAL SWEATERS



These simple but effective designs show two alternative methods of introducing a motif. Intarsia is the most obvious method of introducing a motif and is always effective. However, garter stitch is also a possible method and produces a lovely, subtle textured motif. Why not experiment with this technique using other motifs you have in your collection?

INTARSIA SWEATER

BACK

Push 45 (48) (51) (54) Ns to WP. Cast on as given in additional notes for Knit 1 Purl 1 Rib but knit first 4 rows after waste yarn in col 2. RC 000. MT-5. Using col 1, knit 10 rows. Drop the 3rd and ev foll alt st and pick up as for Knit 1 Purl 1 Rib. Cast off with waste yarn. Push 25 (27) (29) (31) Ns at left and right of centre O to WP. 50 (54) (58) (62) Ns altog. With carr at right pick up sts from below waste yarn and place onto Ns increasing evenly*. RC 000. MT. Using col 1, knit 48 (52) (58) (62) rows. Mark both ends with waste yarn. Knit 36 (38) (40) (42) rows. RC 84 (90) (98) (104). Carr at right.

Shape Back Neck

Using a length of col 1, cast off centre 14 sts. Hold Ns at left.

Knit Right Part as Follows:-

Knit 1 row. Cast off 3 sts beg next row. Cast off rem 15 (17) (19) (21) sts. Take carr to left. Bring Ns back to WP. Knit left part as for right part.

SLEEVES

Push 26 (26) (27) (27) Ns to WP. Cast on as given in additional notes for Knit 1 Purl 1 Rib but knit first 4 rows after waste yarn in col 2. RC 000. MT-5. Using col 1, knit 10 rows. Drop the 3rd and ev foll alt st and pick up as for Knit 1 Purl 1 Rib. Using waste yarn knit several rows and release from machine. Push 32 (32) (33) (33) Ns to WP. Pick up sts from below waste yarn and place onto Ns increasingly evenly. RC 000. MT. Knit 1

Intarsia Sweater

For Knitmaster 9mm Chunky Machines with Intarsia Carriage.
Garter Stitch Sweater
For Knitmaster 9mm Chunky Machines.

Sizes:

To fit 61 (66) (71) (76) cms/24 (26) (28) (30) inch chest.

Materials:

Knitmaster Chunky.
Col 1 (Aran) - 230 (250) (280) (310) grms
Col 2 (Midnight) - 50 (50) (60) (60) grms
2 (2) (3) (3) buttons.

Tensions:

Stockinet - 15 sts and 22 rows to 10 cms. TD at approx. 6 (MT)
Knit 1 Purl 1 Rib - 27 rows to 10 cms. TD at approx. MT-5

Pattern Note:

Intarsia - see chart.
Garter Stitch - see chart.

row. Inc 1 st at both ends of the next and ev foll 6th (6th) (6th) (5th) row 9 (11) (12) (14) times in all. 50 (54) (57) (61) sts. Knit to Row 55 (64) (68) (77). Mark centre with waste yarn. Cast off.

FRONT

Knit as for Back to*. RC 000. MT. Using col 1, knit 6 (8) (10) (12) rows. Continue in intarsia pattern over centre 28 sts. Knit 42 rows. RC 48 (50) (52) (54). Continue in stockinet col 1. Knit 0 (2) (6) (8) rows. RC 48 (52) (58) (62). Mark both ends with waste yarn. Knit 10 (12) (10) (10) rows.

Divide for Front Opening

Using a length of col 1, cast off centre 4 sts. Hold Ns at left.

Knit Right Part as Follows:-

Knit 14 (14) (18) (18) rows. RC 72 (78) (86) (90). Carr at right.

Shape Neck

Knit 1 row. Cast off 3 sts at beg of the next row, knit 1 row. Cast off 2 sts at beg of the next row, knit 1 row. Dec 1 st at neck edge on the next and ev foll 3rd row 3 times in all, knit 2 (2) (2) (4) rows. Cast off rem 15 (17) (19) (21) sts. Take carr to left. Bring Ns back to WP. Knit left part as for right part.

BUTTONHOLE BAND

Push 9 (9) (12) (12) Ns to WP. Cast on as given in additional notes for Knit 1 Purl 1 Rib but knit first 4 rows after waste yarn in col 2. RC 000. MT-5. Using col 1, knit 3 rows. Drop the 3rd and ev foll alt st and pick up as for Knit 1 Purl 1 Rib. Make 2 (2) (3) (3) evenly spaced buttonholes over 1 N. Knit 3 rows. Drop the 3rd and ev foll alt st and pick up as for Knit 1 Purl 1 Rib. Knit 1 row MT. Cast off with waste yarn.

BUTTON BAND

Knit as for Buttonhole band but omit buttonholes.

COLLAR

Push 60 (60) (60) (63) Ns to WP. Cast on as given in additional notes for Knit 1 Purl 1 Rib but knit first 4 rows after

waste yarn in col 2. RC 000. MT-5. Using col 1, knit 18 rows. Drop the 3rd and ev foll alt st and pick up as for Knit 1 Purl 1 Rib. Knit 1 row MT. Cast off with waste yarn.

TO MAKE UP

Pin out to size and steam carefully. Join shoulder seams. Set in sleeves between marked points. Join side and sleeve seams. Backstitch front bands into pos lapping buttonhole band over button band. Neaten lower edge. Backstitch collar into pos starting and finishing at centre of front bands. Sew on buttons.

GARTER STITCH ANCHOR SWEATER

Knit as for Intarsia Anchor Sweater but reverse colours and follow chart in garter stitch.

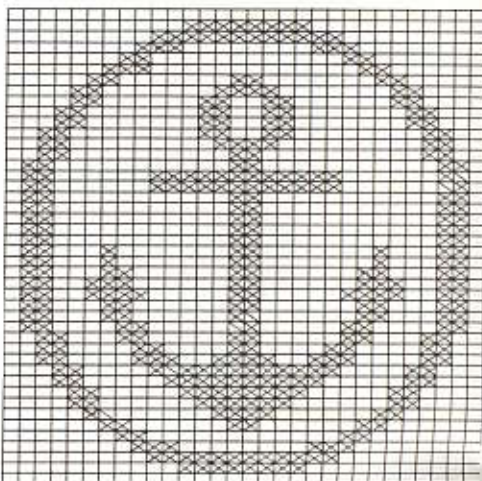

Intarsia sweater

□ = col 1
⊗ = col 2

Garter stitch sweater
⊗ = drop stitch and pick up as for ribbing

Continued on page 37

10 CABLE CARDIGAN WITH FLOWERS



This design uses a cable stitch which has been strategically positioned to create a diamond shape to form a frame around the pretty embroidered flowers. There are lots of different effects you can create using cable stitch and you may like to experiment to see what variations you can come up with. See pattern 6 and 16 for other cable ideas.

BACK

Push 46 (50) (52) (56) Ns to WP. Cast on as given in additional notes for Knit 1 Purl 1 Rib. RC 000. MT-6, knit 10 rows. Drop the 3rd and ev foll alt st and pick up as for Knit 1 Purl 1 Rib. Using waste yarn knit several rows and release from machine. Push 26 (28) (30) (32) Ns at left and right of centre O to WP. 52 (56) (60) (64) Ns altog. With carr at right, pick up sts from below waste yarn and place onto Ns increasing evenly. Mark between the 12th & 13th st each side of centre O with waste yarn. RC 000. MT. Using col 1 continue in cable pattern working centre of cables over marked point. Knit 48 (52) (58) (62) rows. Carr at right.

Shape Armholes

Dec 1 st at both ends of the next and ev foll alt row 5 times in all. 42 (46) (50) (54) sts. Knit 27 (29) (31) (33) rows. RC 84 (90) (98) (104). Carr at right.

Shape Back Neck

Using a length of col 1, cast off centre 16 sts. Hold Ns at left.

Knit Right Part as Follows:—

Cast off 5 (6) (7) (8) sts beg of the next row and 3 sts beg of the next row. Cast off rem 5 (6) (7) (8) sts. Take carr to left. Bring Ns back to WP. Knit left part as for right part.

RIGHT PART

Push 23 (25) (26) (28) Ns to WP. Cast on as given in additional notes for Knit 1 Purl 1 Rib. RC 000. MT-6, knit 10 rows. Drop the 3rd and ev foll alt st and pick up as for Knit 1 Purl 1 Rib. Using waste yarn knit several rows and release from

For Knitmaster 9mm Chunky Machines.

Sizes:

To fit 61 (66) (71) (76) cms/24 (26) (28) (30) inch chest.

Materials:

Knitmaster Chunky.
Col 1 (Aran) — 270 (300) (330) (360) grms
Col 2 (Serpentine) — small amount
Col 3 (Pink) — small amount
Col 4 (Inca) — small amount
Col 5 (Bluebell) — small amount
Col 6 (Pale Blue) — small amount
9 (9) (10) (10) buttons.

machine. Push 26 (28) (30) (32) Ns at right of centre O to WP. With carr at right, pick up sts from below waste yarn and place onto Ns increasing evenly. Mark between the 12th & 13th st at right of centre O with waste yarn. RC 000. MT. Using col 1, continue in cable pattern working centre of cable over marked point. Knit 48 (52) (58) (62) rows. (Knit 1 row extra for Left Front Only). Carr at right.

Shape Armhole

Dec 1 st at beg of the next and ev foll alt row 5 times in all. 21 (23) (25) (27) sts. Knit 15 (17) (19) (19) rows. RC 72 (78) (86) (90). Carr at right.

Shape Neck

Knit 1 row. Cast off 3 sts at beg of the next and foll alt row, knit 1 row. Cast off 2 sts at beg of the next row, knit 1 row. Dec 1 st at beg of the next and ev foll alt row 3 times in all, knit 0 (0) (0) (2) rows. RC 84 (90) (98) (104). Carr at right.

Shape Shoulder

Cast off 5 (6) (7) (8) sts beg of the next row, knit 1 row. Cast off rem 5 (6) (7) (8) sts.

LEFT FRONT

Knit as for Right Front but note alteration in number of rows worked and reading left for right.

SLEEVES

Push 26 (26) (28) (28) Ns to WP. Cast on as given in additional notes for Knit 1 Purl 1 Rib. RC 000. MT-6, knit 10 rows. Drop the 3rd and ev foll alt st and pick up as for Knit 1 Purl 1 Rib. Using waste yarn knit several rows and release from machine. Push 15 (15) (16) (16) Ns at left and right of centre O to WP. 30 (30) (32) (32) Ns altog. With carr at right, pick up sts from below waste yarn and place onto Ns increasing evenly. RC 000. MT. Using col 1, continue in cable pattern working centre of cable over centre O. Knit 2 (2) (2) (0) rows. Inc 1 st at both ends of the next and ev foll 5th row 10 (11) (12) (14) times in all. 50 (52) (56) (60) sts. Knit to Row 49 (58) (62) (66). Mark both ends with waste yarn.

Tensions:

Stockinet & Cable — 15.5 sts and 22 rows to 10 cms. TD at approx. 7 (MT)
Knit 1 Purl 1 Rib — 27 rows to 10 cms. TD at approx. MT-6

Pattern Note:

Cable Pattern — follow chart. Knit throughout chart once, then repeat first 5 rows of chart to end.

Shape Top

Dec 1 st at both ends of the next and ev foll alt row 4 times in all, knit 1 row. Cast off 9 (10) (11) (12) sts at beg of the next 2 rows and 9 (9) (10) (11) sts at beg of the next 2 rows. Mark centre with waste yarn. Cast off rem 6 sts.

NECKBAND

Push 62 (62) (62) (65) Ns to WP. Cast on as given in additional notes for Knit 1 Purl 1 Rib. RC 000. MT-6, knit 14 rows. Drop the 3rd and ev foll alt st and pick up as for Knit 1 Purl 1 Rib. Knit 1 row MT. Cast off with waste yarn.

BUTTONHOLE BAND

Push 60 (65) (70) (73) Ns to WP. Cast on as given in additional notes for Knit 1 Purl 1 Rib. RC 000. MT-6, knit 4 rows. Drop the 3rd and ev foll alt st and pick up as for Knit 1 Purl 1 Rib. Make 9 (9) (10) (10) evenly spaced buttonholes over 1 N. Knit 4 rows. Drop the 3rd and ev foll alt st and pick up as for Knit 1 Purl 1 Rib. Knit 1 row MT. Cast off with waste yarn.

BUTTON BAND

Knit as for Buttonhole Band but omit buttonholes.

TO MAKE UP

Pin out to size and steam carefully. Join shoulder seams. Set in sleeves. Join side and sleeve seams. Backstitch neckband into pos. Backstitch front bands into pos including along edge of neckband. Sew on buttons to correspond with buttonholes. Swiss darn following chart. Give final light steam.

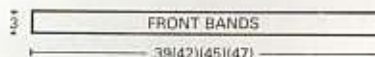
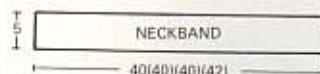

Continued on page 38



10



12



11

11 ROSE SWEATER



We've Swiss Darned the lovely big flower motif onto the front of this sweater but you could just as easily knit it by intarsia if you prefer. You can also substitute our flower motif with other motifs if you like. You'll find lots to choose from at your local stockist and handknitting patterns are often a good source for children's intarsia motifs.

BACK

Push 45 (48) (51) (54) Ns to WP. Cast on as given in additional notes for Knit 1 Purl 1 Rib. RC 000. MT-5, knit 10 rows. Drop the 3rd and ev foll alt st and pick up as for Knit 1 Purl 1 Rib. Cast off with waste yarn. Push 25 (27) (29) (31) Ns at left and right of centre O to WP. 50 (54) (58) (62) Ns altog. With carr at right, pick up sts from below waste yarn and place onto Ns increasing evenly. RC 000. MT. Using col 1, knit 48 (52) (58) (62) rows. Mark both ends with waste yarn*.

Shape Back Neck

Using a length of col 1, cast off centre 14 sts. Hold Ns at left.

Knit Right Part as Follows:-

Knit 1 row. Cast off 3 sts beg next row. Cast off rem 15 (17) (19) (21) sts. Take carr to left. Bring Ns back to WP. Knit left part as for right part.

FRONT

Knit as for Back to*. Knit 24 (26) (28) (28) rows. RC 72 (78) (86) (90). Carr at right. Shape Neck

Using a length of col 1, cast off centre 10 sts. Hold Ns at left.

Knit Right Part as Follows:-

Knit 1 row. Cast off 2 sts at beg of the next row, knit 1 row. Dec 1 st at neck edge on the next and ev foll 3rd row 3 times in all, knit 4 (4) (4) (6) rows. Cast off rem 15 (17) (19) (21) sts. Take carr to left. Bring Ns back to WP. Knit left part as for right part.

For Knitmaster 9mm Chunky Machines.

Sizes:

To fit 61 (66) (71) (76) cms/24 (26) (28) (30) inch chest.

Materials:

Knitmaster Chunky.
Col 1 (Midnight) – 260 (290) (320) (350) grms
Col 2 (Pink) – small amount
Col 3 (Geranium) – small amount
Col 4 (Inca) – small amount
Col 5 (Serpentine) – small amount
Col 6 (Opal) – small amount
Col 7 (Bright Pink) – small amount –

(chunky type yarn)
Col 8 (Bluebell) – small amount

Tensions:

Stockinet – 15 sts and 22 rows to 10 cms. TD at approx. 6 (MT)
Knit 1 Purl 1 Rib – 27 rows to 10 cms. TD at approx. MT-5

Pattern Note:

Stockinet. Swiss darn following chart.

SLEEVES

Push 26 (26) (27) (27) Ns to WP. Cast on as given in additional notes for Knit 1 Purl 1 Rib. RC 000. MT-5, knit 10 rows. Drop the 3rd and ev foll alt st and pick up as for Knit 1 Purl 1 Rib. Using waste yarn knit several rows and release from machine. Push 16 (16) (17) (17) Ns at left and right of centre O to WP. 32 (32) (34) (34) Ns altog. Pick up sts from below waste yarn and place onto Ns increasing evenly. RC 000. MT. Using col 1, knit 1 row. Inc 1 st both ends next and ev foll 6th row 9 (11) (12) (13) times in all. 50 (54) (58) (60) sts. Knit to Row 55 (64) (68) (77). Mark centre with waste yarn. Cast off.

COLLAR

Push 60 (60) (60) (63) Ns to WP. Cast on as given in additional notes for Knit 1 Purl 1 Rib. RC 000. MT-5, knit 22 rows. Drop the 3rd and ev foll alt st and pick up as for Knit 1 Purl 1 Rib. Knit 1 row MT. Cast off with waste yarn.

TO MAKE UP

Pin out to size and steam carefully. Join shoulder seams. Set in sleeves between marked points. Join side and sleeve seams. Backstitch collar into pos. Swiss darn flower on front following chart. Give final light steam.

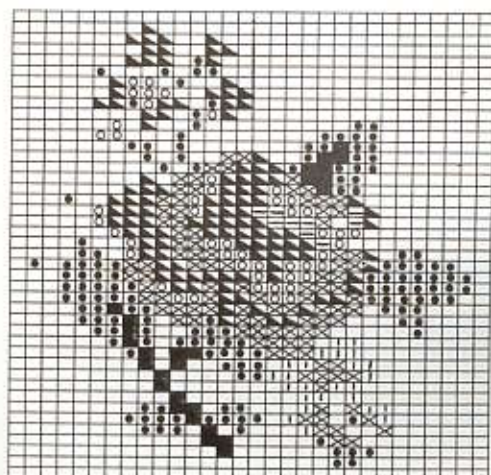
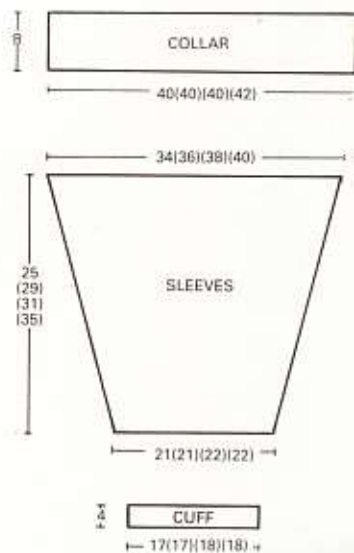
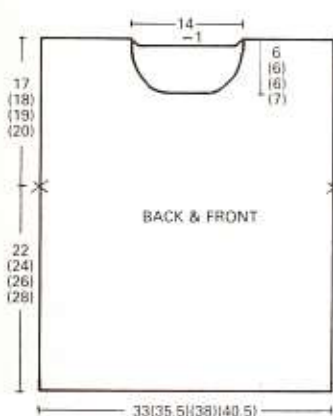

- = col 1
- × = col 2
- ▲ = col 3
- = col 4
- = col 5
- = col 6
- = col 7
- | = col 8

12 CARDIGAN WITH FLORAL BORDER



For Knitmaster 9mm Chunky Machines.

Sizes:

To fit 61 (66) (71) (76) cms/24 (26) (28) (30) inch chest.

Materials:

Knitmaster Chunky.
Col 1 (Geranium) – 260 (290) (320) (350) grms
Col 2 (Serpentine) – small amount
Col 3 (Inca) – small amount
Col 4 (Bluebell) – small amount
7 (7) (8) (8) buttons.

Tensions:

Stockinet – 15 sts and 22 rows to 10 cms. TD at approx. 6 (MT)
Knit 1 Purl 1 Rib – 27 rows to 10 cms. TD at approx. MT-5

Pattern Note:

Swiss darn flower border following chart.

Swiss Darning and embroidery on knitwear is fashionable at the moment, not just for adults but for children too. If you're not too familiar with embroidery stitches, it'll certainly be worthwhile practising and perfecting this decorative technique since it really is a very important feature of knitwear design at the moment. And, of course it's actually quite easy using chunky yarn.

BACK

Push 45 (48) (51) (54) Ns to WP. Cast on as given in additional notes for Knit 1 Purl 1 Rib. RC 000. MT-5, knit 10 rows. Drop the 3rd and ev foll alt st and pick up as for Knit 1 Purl 1 Rib. Using waste yarn knit several rows and release from machine. Push 25 (27) (29) (31) Ns at left and right of centre O to WP. 50 (54) (58) (62) Ns altog. With carr at right, pick up sts from below waste yarn and place onto Ns increasing evenly. RC 000. MT. Using col 1, knit 48 (52) (58) (62) rows. Carr at right.

Shape Armholes

Cast off 3 sts at beg of the next 2 rows. 44 (48) (52) (56) sts. Knit 34 (36) (38) (40) rows. RC 84 (90) (98) (104). Carr at right.

Shape Back Neck

Using a length of col 1, cast off centre 14 sts. Hold Ns at left.

Knit Right Part as Follows:-

Knit 1 row. Cast off 3 sts beg next row. Cast off rem 12 (14) (16) (18) sts. Take carr to left. Bring Ns back to WP. Knit left part as for right part.

RIGHT FRONT

Push 22 (24) (26) (27) Ns to WP. Cast on as given in additional notes for Knit 1 Purl 1 Rib. RC 000. MT-5, knit 10 rows. Drop the 3rd and ev foll alt st and pick up as for Knit 1 Purl 1 Rib. Using waste yarn knit several rows and release from machine. Push 25 (27) (29) (31) Ns at right of centre O to WP. With carr at right, pick up sts from below waste yarn and place onto Ns increasing evenly. RC

000. MT. Using col 1, knit 48 (52) (58) (62) rows. (Knit 1 row extra for Left Front only). Carr at right.

Shape Armhole

Cast off 3 sts at beg of the next row, knit 23 (25) (27) (27) rows. RC 72 (78) (86) (90). Carr at right.

Shape Neck

Knit 1 row. Cast off 5 sts at beg of the next row, knit 1 row. Cast off 2 sts at beg of the next row, knit 1 row. Dec 1 st at neck edge on the next and ev foll 3rd row 3 times in all, knit 2 (2) (2) (4) rows. Cast off rem 12 (14) (16) (18) sts.

LEFT FRONT

Knit as for Right Front but note alteration in number of rows worked and read left for right.

SLEEVES

Push 26 (26) (27) (27) Ns to WP. Cast on as given in additional notes for Knit 1 Purl 1 Rib. RC 000. MT-5, knit 10 rows. Drop the 3rd and ev foll alt st and pick up as for Knit 1 Purl 1 Rib. Using waste yarn knit several rows and release from machine. Push 16 (16) (17) (17) Ns at left and right of centre O to WP. 32 (32) (34) (34) Ns altog. Pick up sts from below waste yarn and place onto Ns increasing evenly. RC 000. MT. Using col 1, knit 1 row. Inc 1 st both ends next and ev foll 6th row 9 (11) (12) (13) times in all. 50 (54) (58) (60) sts. Knit to Row 55 (64) (68) (77). Mark both ends with waste yarn. Knit 4 rows. Mark centre with waste yarn. Cast off.

BUTTONHOLE BAND

Push 56 (60) (65) (68) Ns to WP. Cast on as given in additional notes for Knit 1 Purl 1 Rib. RC 000. MT-5, knit 4 rows. Drop the 3rd and ev foll alt st and pick up as for Knit 1 Purl 1 Rib. Make 7 (7) (8) (8) evenly spaced buttonholes over 1 N. Knit 4 rows. Drop the 3rd and ev foll alt st and pick up as for Knit 1 Purl 1 Rib. Knit 1 row MT. Cast off with waste yarn.

BUTTON BAND

Knit as for Buttonhole Band but omit buttonholes.

COLLAR

Push 65 (65) (65) (68) Ns to WP. Cast on as given in additional notes for Knit 1 Purl 1 Rib. RC 000. MT-5, knit 22 rows. Drop the 3rd and ev foll alt st and pick up as for Knit 1 Purl 1 Rib. Knit 1 row MT. Cast off with waste yarn.

TO MAKE UP

Pin out to size and steam carefully. Join shoulder seams. Set in sleeves sewing rows above marker to cast off sts at armhole. Join side and sleeve seams. Backstitch bands into pos. Backstitch collar into pos starting and finishing at centre of bands. Sew on buttons to correspond with buttonholes. Swiss darn flowers following chart. Embroider flowers around collar using cols 3 & 4 alternately. Give final light steam.

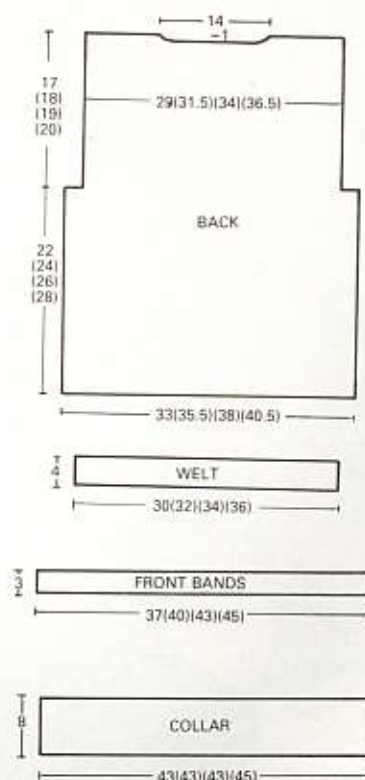

Continued on page 43

13A

14



13B



13A & B CHECKERED SWEATERS WITH MOTIFS



For Knitmaster 9mm Chunky Machines.

Pattern Note:
Garter Stitch – see chart.

Sizes:

To fit 61 (66) (71) (76) cms/24 (26) (28) (30) inch chest.

Materials:

Knitmaster Chunky.
Col 1 (Oatmeal) – 270 (300) (330) (360) grms
Col 2 (Bluebell) – small amount
Col 3 (Serpentine) – small amount
Col 4 (Inca) – small amount

Tensions:

Stockinet – 15 sts and 22 rows to 10 cms. TD at approx. 6 (MT)

These 3 delightful designs not only use the extremely popular Swiss Darning technique to decorate them but also feature an interesting combination of two additional techniques. The subtle chequered effect has been created using garter stitch for the horizontal lines and a reformed rib stitch for the vertical lines. These designs also look very good without Swiss Darning.

Version (A)

BACK

Push 27 (29) (31) (33) Ns at left and right of centre O to HP. 54 (58) (62) (66) Ns altog. Using col 2, cast on by hand. Push Ns to UWP. RC 000. MT. Knit 2 rows garter st col 2, 2 rows garter st col 3, 2 rows garter st col 4. RC 000. Continue in col 1. Following garter st chart, knit 46 (50) (54) (60) rows. Mark both ends with waste yarn*. Knit 36 (38) (40) (42) rows. RC 82 (88) (94) (102). Carr at right.

Shape Back Neck

Using a length of col 1, cast off centre 14 sts. Hold Ns at left.

Knit Right Part as Follows:-

Knit 1 row. Cast off 3 sts beg next row. Cast off rem 17 (19) (21) (23) sts. Take carr to left. Bring Ns back to WP. Knit left part as for right part.

FRONT

Knit as for Back to*. Knit 24 (26) (28) (28) rows. RC 70 (76) (82) (88). Carr at right.

Shape Neck

Using a length of col 1, cast off centre 10 sts. Hold Ns at left.

Knit Right Part as Follows:-

Knit 1 row. Cast off 2 sts beg next row, knit 1 row. Dec 1 st at neck edge on the next and ev foll 3rd row 3 times in all. Knit 4 (4) (4) (6) rows. Cast off rem 17 (19) (21) (23) sts. Take carr at left. Bring Ns back to WP. Knit left part as for right part.

SLEEVES

Push 26 (26) (28) (28) Ns to HP. Using col 2, cast on by hand. Push Ns to UWP. RC 000. MT. Knit 2 rows garter st col 2, 2 rows garter st col 3, 2 rows garter st col 4. Using waste yarn knit several rows and release from machine. Push 14 (14) (15) (15) Ns at left and right of centre O to WP. 28 (28) (30) (30) Ns altog. Pick up sts from below waste yarn and place onto Ns increasing evenly. RC 000. MT. Continue in col 1. Following garter st chart. Knit 1 (0) (0) (1) row. Inc 1 st at both ends of the next and ev foll 5th row 11 (13) (14) (15) times in all. 50 (54) (58) (60) sts. Knit 1 (0) (0) (2) rows. RC 53 (61) (66) (74). Mark centre with waste yarn. Cast off.

NECKBAND

Pin out to size and steam carefully. Join

one shoulder seam. Push 60 (60) (60) (63) Ns to WP. With wrong side facing, pick up neck edge and place onto Ns in WP. RC 000. MT. Knit 2 rows garter st col 4, 2 rows garter st col 3, 2 rows garter st col 2. MT+4, knit 1 rows col 2. Cast off.

TO MAKE UP

Join rem shoulder seam. Set in sleeves between marked points. Join side and sleeve seams. Following chart swiss darn in squares across front, back and sleeves as shown.

Version (B)

Knit as for version A but knit garter st bands in col 1 and swiss darn in squares over front and sleeves as shown.

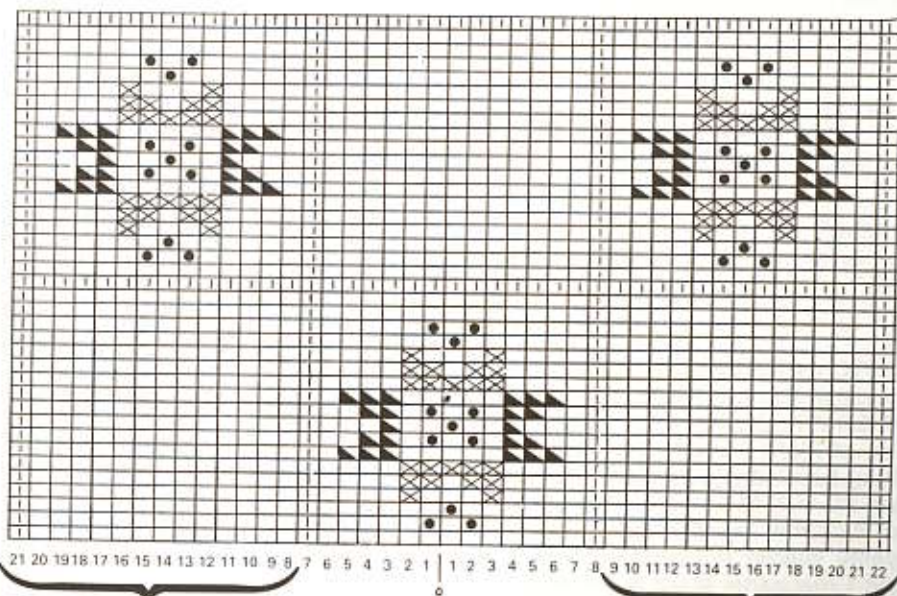

Repeat to end

Repeat to end

Swiss Darning
● = col 4
X = col 3
▲ = col 2

| = drop stitch and reform as for ribbing

Continued on page 37

14 CHECKERED CARDIGAN WITH MOTIFS



For Knitmaster 9mm Chunky Machines.

Sizes:

To fit 61 (66) (71) (76) cms/24 (26) (28) (30) inch chest.

Materials:

Knitmaster Chunky.
Col 1 (Oatmeal) – 270 (300) (330) (360) grms
Col 2 (Midnight) – small amount
Col 3 (Capri) – small amount
Col 4 (Pink) – small amount
9 (9) (10) (10) buttons.

Tensions:

Stockinet – 15 sts and 22 rows to 10 cms. TD at approx. 6 (MT)

Pattern Note:

Garter Stitch – Knit 2 rows. Drop ev st 1 row down and pick up as for ribbing.

Back and Sleeves – see chart 1

Front – see chart 2

BACK

Knit as for Back on Checkered Sweater.

RIGHT FRONT

Push 27 (29) (31) (33) Ns at right and 4 Ns at left of centre O to HP. 31 (33) (35) (37) Ns altog. Using col 2, cast on by hand. Push Ns to UWP. RC 000. MT. Knit 2 rows garter st col 2, 1 row col 3. Make a buttonhole over N 3 at left of centre O. Knit 1 row garter st col 3, 2 rows garter st col 4. Using a small length of col 4, cast off 4 sts at left of centre O. RC 000. Continue in col 1. Following garter st chart, knit 46 (50) (54) (60) rows. Mark right edge with waste yarn. Knit 23 (25) (27) (27) rows. RC 69 (75) (81) (87). Carr at left.

Shape Neck

Cast off 5 sts beg next row, knit 1 row. Cast off 2 sts beg next row, knit 1 row. Dec 1 st at neck edge on the next and ev foll 3rd row 3 times in all, knit 4 (4) (4) (6) rows. Cast off rem 17 (19) (21) (23) sts.

LEFT FRONT

Knit as for Right Front but in reverse and omit buttonhole.

SLEEVES

Knit as for Sleeves on Checkered Sweater.

BUTTONHOLE BAND

Pin out to size and steam carefully. Push 48 (53) (57) (60) Ns to WP. With wrong side of Right Front facing, pick up sts along front edge and place onto Ns in WP. RC 000. MT. Knit 2 rows garter st col 4, 1 row col 3. Make 7 (7) (8) (8) evenly spaced buttonholes over 1 N. Knit 1 row garter st col 3, 2 rows garter st col 2. MT+4, knit 1 row col 2. Cast off.

BUTTON BAND

Knit as for Buttonhole Band omit buttonholes.

NECKBAND

Join shoulder seams. Push 68 (68) (68) (71) Ns to WP. With wrong side facing, pick up neck edge including top of bands and place onto Ns in WP. RC 000. MT. Knit 2 rows garter st col 4, 1 row st col 3. Counting from the left edge make a buttonhole over N 3. Knit 1 row garter st col 3, 2 rows garter st col 2. MT+4, knit 1 row col 2. Cast off.

TO MAKE UP

Pin out to size and steam carefully. Set in sleeves between marked points. Join side and sleeve seams. Sew on buttons to correspond with buttonholes. Following chart swiss darn in squares as shown.

Chart 1 — Back & Sleeves

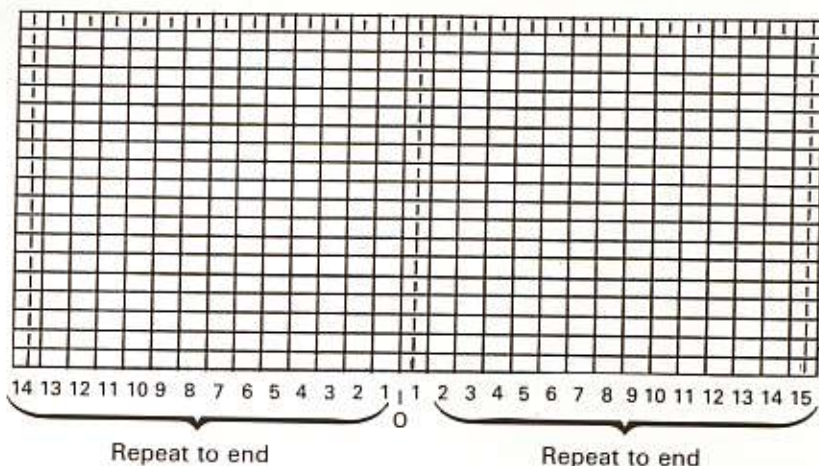
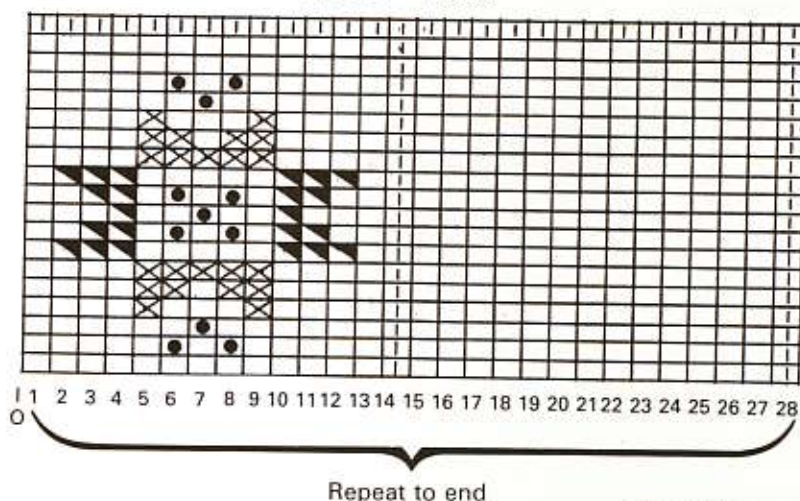

Chart 2 — Fronts



l = drop stitches and reform as for ribbing

● = col 3
X = col 4
▲ = col 2

Pattern 14 Continued

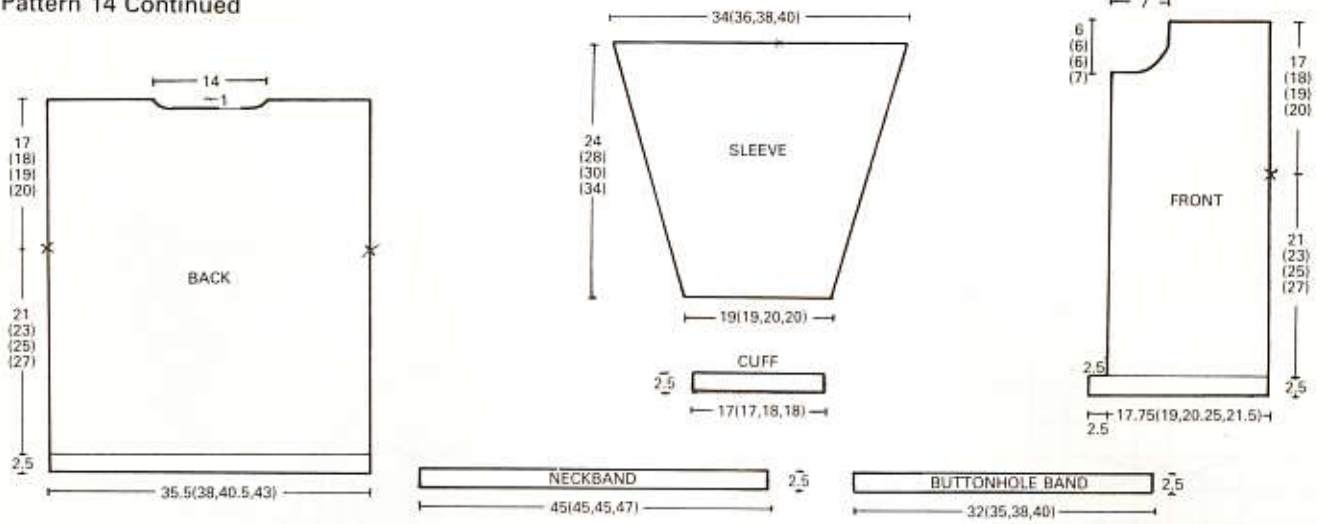

PATTERN 13

Continued from page 35

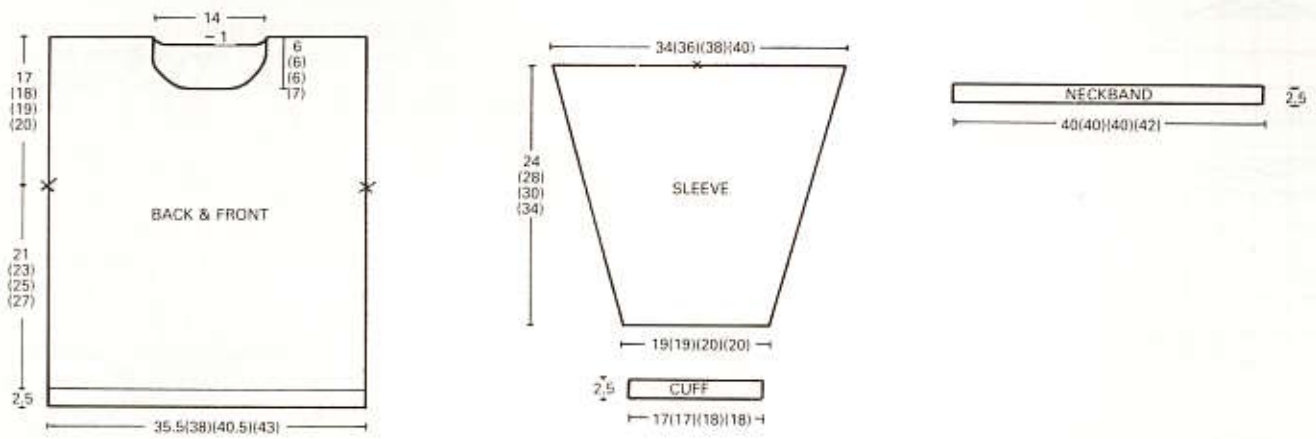

PATTERN 9

Continued from page 28

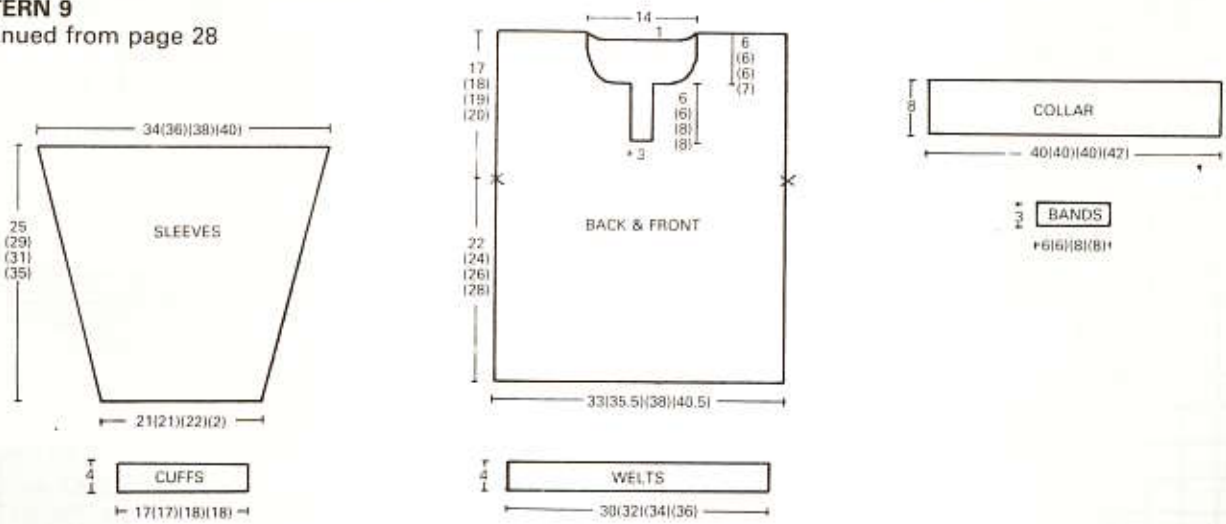

PATTERN 5

Continued from page 23

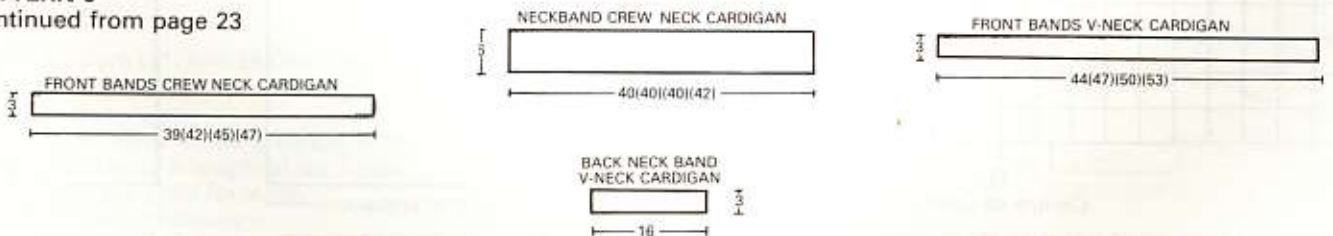

PATTERN 10

Continued from page 29

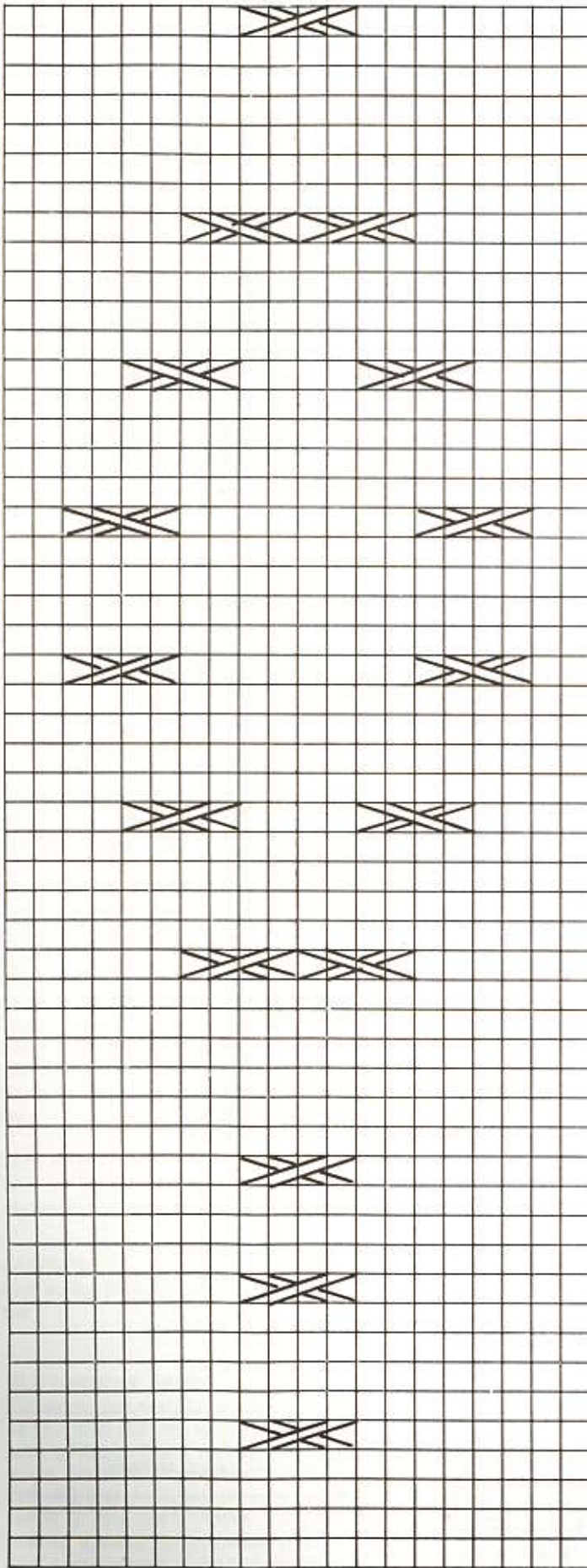

O
Centre of Cable

- = Cross sts at left over sts at right.
- = Cross sts at right over sts at left.

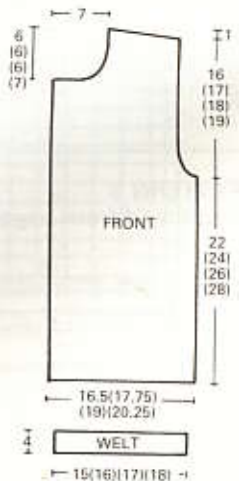
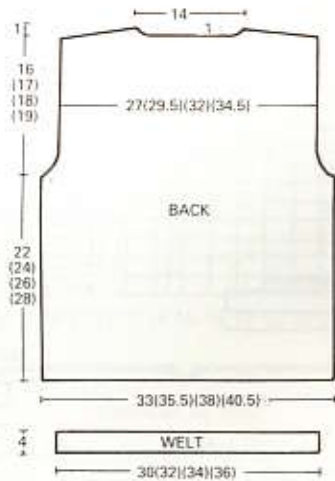
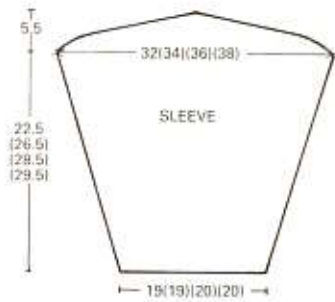
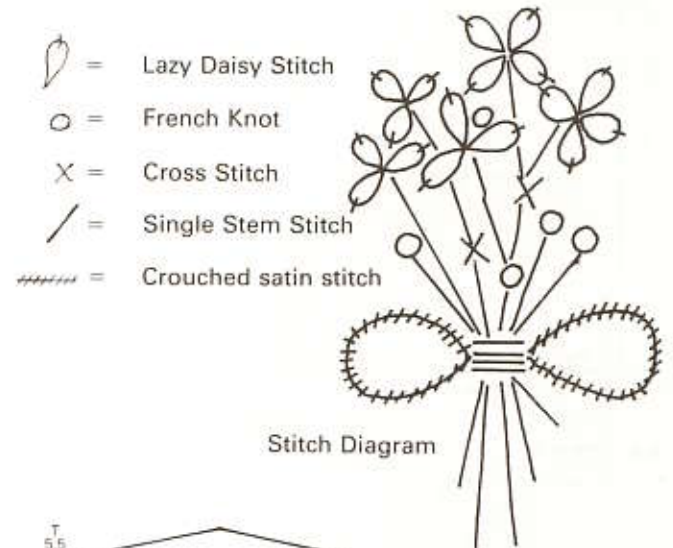
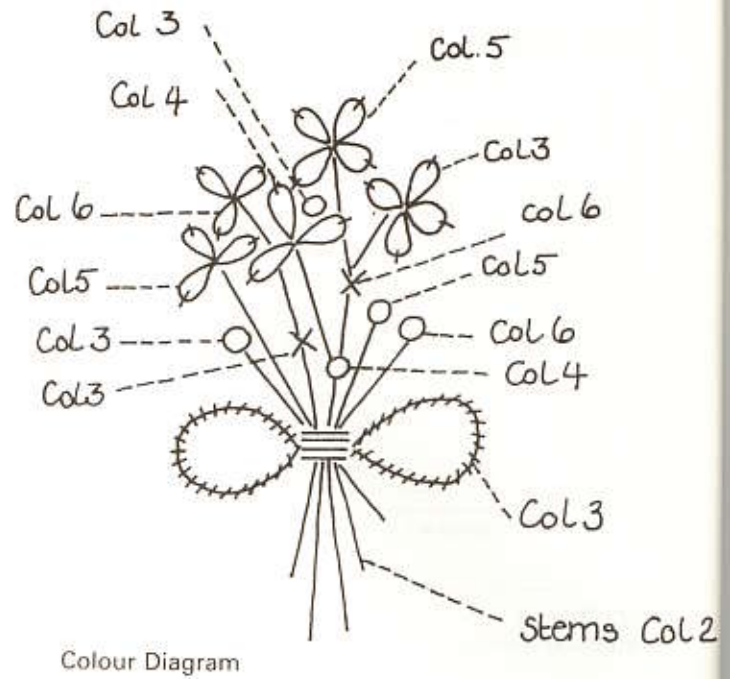

15 GEOMETRIC GARTER STITCH SWEATER



For Knitmaster 9mm Chunky Machines.

Sizes:
To fit 61 (66) (71) (76) cms/24 (26) (28) (30) inch chest.

Materials:
Knitmaster Chunky.
Col 1 (Capri)–290 (320) (350) (380) grms

Tensions:
Pattern – 16 sts and 23 rows to 10 cms. TD at approx. 6 (MT)
Knit 1 Purl 1 Rib – 27 rows to 10 cms. TD at approx. MT-5

Pattern Note:
Garter Stitch – follow chart.

Note:
When shaping neckband, before pushing Ns to HP drop the sts and pick up as for Knit 1 Purl 1 Rib.

This heavily textured pattern has been created using garter stitch but could certainly be confused with an intricate hand knitted design! If you look at the garter stitch chart you will see that you could easily work out some of your own heavily textured garter stitch patterns. Why not try knitting one or two of your own ideas.

BACK

Push 48 (51) (54) (57) Ns to WP. Cast on as given in additional notes for Knit 1 Purl 1 Rib. RC 000. MT-5. Using col 1, knit 10 rows. Drop the 3rd and ev foll alt st and pick up as for Knit 1 Purl 1 Rib. Using waste yarn knit several rows and release from machine. Push 29 (31) (33) (35) Ns at left and right of centre O to WP. With carr at right, pick up sts from below waste yarn and place onto Ns increasing evenly. RC 000. MT. Continue in garter stitch pattern. Knit 50 (54) (60) (64) rows. Carr at right.

Shape Armholes

Cast off 5 sts beg of the next 2 rows. 48 (52) (56) (60) sts*. Knit 36 (38) (40) (42) rows. RC 88 (94) (102) (108). Carr at right.

Shape Back Neck

Note pos in pattern. Using a length of col 1, cast off centre 18 sts. Hold Ns at left.

Knit Right Part as follows:–

Knit 1 row. Cast off 2 sts beg of the next row. Cast off rem 13 (15) (17) (19) sts. Take carr to left. Bring Ns back to WP. Keeping pattern correct, knit left part as for right part.

FRONT

Knit as for Back to*. Knit 24 (26) (28) (28) rows. RC 76 (82) (90) (94). carr at right.

Shape Neck

Note pos in pattern. Mark centre with waste yarn. Using a length of col 1, cast off centre 10 sts. Hold Ns at left.

Knit Right Part as Follows:–

Knit 1 row. Cast off 2 sts at beg of the next row, knit 1 row. Dec 1 st at neck edge on the next and ev foll alt row 4

times in all, knit 4 (4) (4) (6) rows. Cast off rem 13 (15) (17) (19) sts. Take carr to left. Bring Ns back to WP. Keeping pattern correct, knit left part as for right part.

SLEEVES

Push 27 (27) (29) (29) Ns to WP. Cast on as given in additional notes for Knit 1 Purl 1 Rib. RC 000. MT-5. Using col 1, knit 10 rows. Drop the 3rd and ev foll alt st and pick up as for Knit 1 Purl 1 Rib. Using waste yarn knit several rows and release from machine. Push 34 (34) (35) (35) Ns to WP. Carr at right. Pick up sts from below waste yarn and place onto Ns increasing evenly. RC 000. MT. Continue in garter stitch pattern. Knit 0 (4) (4) (4) rows. Inc 1 st at both ends of the next and ev foll 6th (5th) (5th) (5th) row 10 (12) (13) (15) times in all. 54 (58) (61) (65) sts. Knit 0 (4) (4) (3) rows. RC 55 (64) (69) (78). Mark both ends with waste

yarn. Knit 7 rows. Mark centre with waste yarn. Cast off.

NECKBAND

Push 64 (64) (64) (68) Ns to WP. Cast on as given in additional notes for Knit 1 Purl 1 Rib. RC 000. MT-5. Using col 1, knit 1 row. Always taking yarn round first inside N in HP, push 1 N at opposite end to carr to HP on the next 8 rows and 2 Ns on the next 2 rows. Break yarn. Using a transfer tool, bring Ns in HP back to WP. Knit 1 row MT. Cast off with waste yarn.

TO MAKE UP

Pin out to size and steam carefully. Join shoulder seams. Set in sleeves sewing rows above marker to cast off sts at armhole. Join side and sleeve seams. Backstitch collar into pos starting and finishing at centre front. Give final light steam.

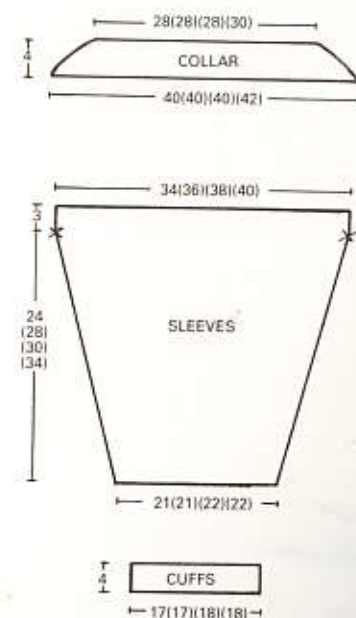
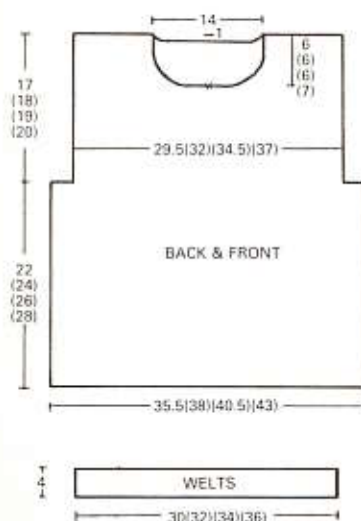

Continued on page 43

15



M.M.P.

CANADIAN PACIFIC
MONTREAL

WATER WITH
is SHAWL
MOTIF

16



16 SHAWL COLLAR CABLE SWEATER WITH MOTIFS



For Knitmaster 9mm Chunky Machines.

Sizes:

To fit 61 (66) (71) (76) cms/24 (26) (28) (30) inch chest.

Materials:

Knitmaster Chunky.
Col 1 (Aran) – 320 (350) (380) (410) grms
Col 2 (Pale Blue) – small amount
Col 3 (Serpentine) – small amount
Col 4 (Bluebell) – small amount

Tensions:

Stockinet & Cables – 16.5 sts and 23 rows to 10 cms. TD at approx. 6 (MT)

Knit 1 Purl 1 Rib – 27 rows to 10 cms. TD at approx. MT-5

Pattern Note:

Follow chart for cable pattern.

Note:

When shaping collar, drop sts and pick up as for ribbing before pushing Ns to HP.

Cables are a lovely way of introducing texture into any design and are particularly effective knitted in chunky yarn. This design has been further embellished with bands of Swiss Darning which make this simple sweater look very exclusive indeed. In fact, just think what a sweater like this would cost to buy in the shops!

BACK

Push 50 (53) (56) (59) Ns to WP. Cast on as given in additional notes for Knit 1 Purl 1 Rib. RC 000. MT-5. Knit 10 rows. Drop the 3rd and ev foll alt st and pick up as for Knit 1 Purl 1 Rib. Using waste yarn knit several rows and release from machine. Push 28 (30) (32) (34) Ns at left and right of centre O to WP. 56 (60) (64) (68) Ns altog. With carr at right, pick up sts from below waste yarn and place onto Ns increasing evenly. RC 000. MT. Using col 1, continue in cable pattern. Knit 50 (54) (60) (64) rows. Mark both ends with waste yarn*. Knit 38 (40) (42) (44) rows. RC 88 (94) (102) (108). Carr at right.

Shape Back Neck

Note pos in pattern. Using a length of col 1, cast off centre 18 sts. Hold Ns at left.

Knit Right Part as Follows:—

Knit 1 row. Cast off 3 sts beg next row. Cast off rem 16 (18) (20) (22) sts. Take carr to left. Bring Ns back to WP. Knit left part as for right part.

FRONT

Knit as for Back to*. Knit 12 (14) (14) (16) rows. RC 62 (68) (74) (80). Carr at right.

Shape Neck

Using a length of col 1, cast off centre 16 sts. Hold Ns at left.

Knit Right Part as Follows:—

Knit 6 rows. Dec 1 st at neck edge on the next and ev foll 6th row 4 times in all, knit 3 (3) (5) (5) rows. Cast off rem 16 (18) (20) (22) sts. Take carr to left. Bring

Ns back to WP. Knit left part as for right part.

SLEEVES

Push 28 (28) (30) (30) Ns to WP. Cast on as given in additional notes for Knit 1 Purl 1 Rib. RC 000. MT-5, knit 10 rows. Drop the 3rd and ev foll alt st and pick up as for Knit 1 Purl 1 Rib. Using waste yarn knit several rows and release from machine. Push 17 (17) (18) (18) Ns at left and right of centre O to WP. 34 (34) (36) (36) Ns altog. Pick up sts from below waste yarn and place onto Ns increasing evenly. RC 000. MT. Using col 1, continue in cable pattern. Knit 1 row. Inc 1 st at both ends of the next and ev foll 5th row 11 (13) (13) (15) times in all. 56 (60) (62) (66) sts. Knit to Row 57 (66) (71) (80). Mark centre with waste yarn. Cast off.

COLLAR

Push 33 (33) (35) (35) Ns at left and right of centre O to WP. 66 (66) (70) (70) Ns altog. Cast on as given in additional notes for Knit 1 Purl 1 Rib. RC 000. MT-5, knit 27 rows. Drop the 3rd and ev foll alt st and pick up as for Knit 1 Purl 1 Rib.

Shape Top

Push 6 Ns at opposite end to carr to HP on the next 4 rows and 5 (5) (6) (6) Ns on the next 4 rows. 22 Ns rem in WP. Using a latch tool bring Ns in HP back to WP. Knit 1 row MT. Cast off with waste yarn.

TO MAKE UP

Pin out to size and steam carefully. Join shoulder seams. Set in sleeves between marked points. Join side and sleeve seams. Backstitch collar into pos overlapping at front. Swiss darn following chart. Give final light steam.

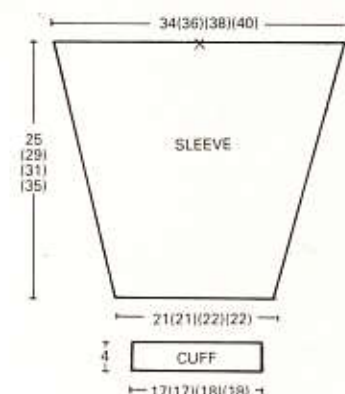
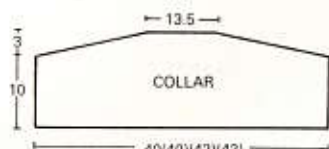
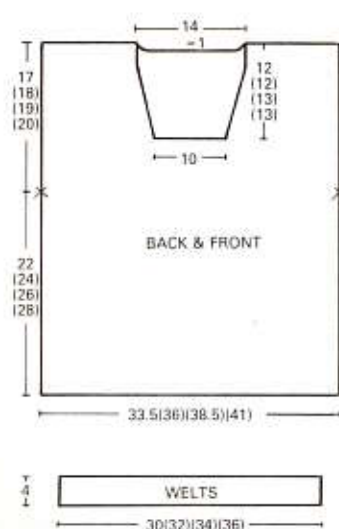

Continued on page 43

PATTERN 7

Continued from page 21

CARDIGAN WITH SWISS BRAID AND FROGGING

Follow instructions for Crew Neck Cardigan but omit buttonholes on front band.

FROGGING CLASPS

Twist 2 ends of black 4ply very tightly, then fold in half allowing the cord to twist back on itself until the cord is stable. Make into frogging clasps following diagram. Sew into pos and sew on buttons to correspond.

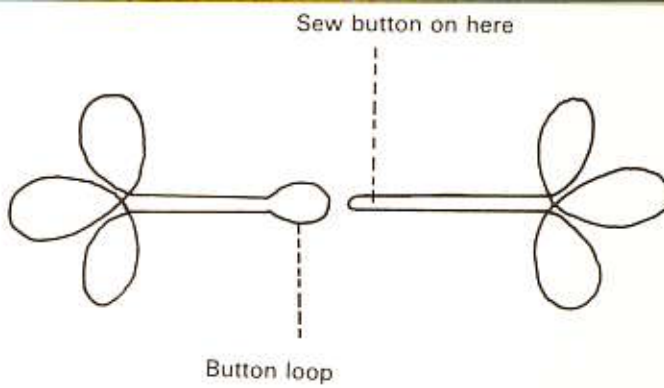

PATTERN 12

Continued from page 33

RIGHT FRONT

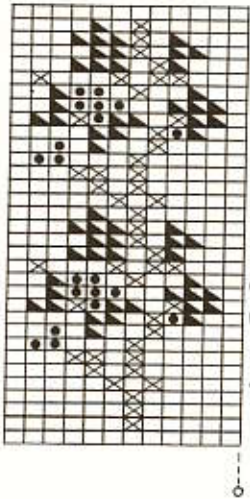

LEFT FRONT

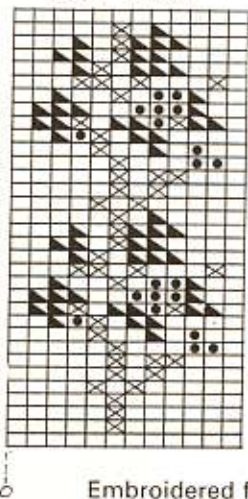

repeat to top

repeat to top

Embroidered flowers

- Swiss Darn Flowers
- X = Serpentine
- ▲ = Bluebell
- = Inca

- french knot
- single satin st
- chain st

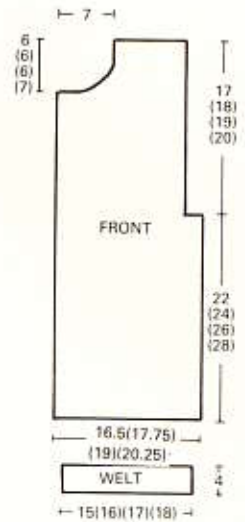
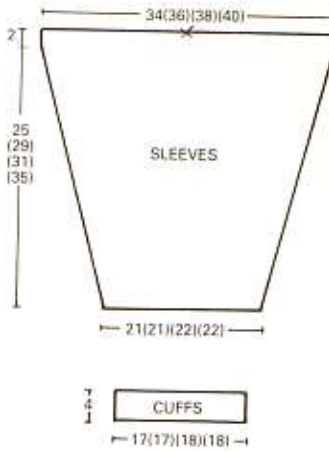

PATTERN 15 Continued from page 39

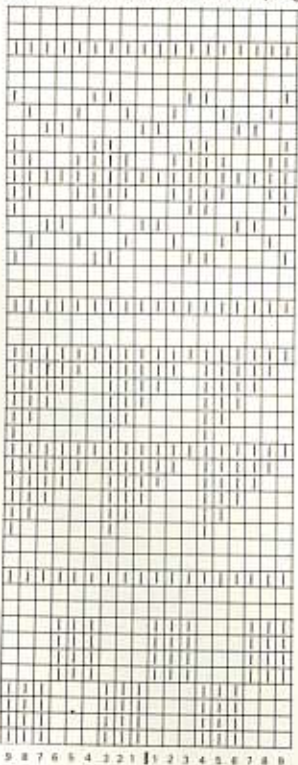

| = drop stitches and reform as for ribbing

PATTERN 16

Continued from page 42

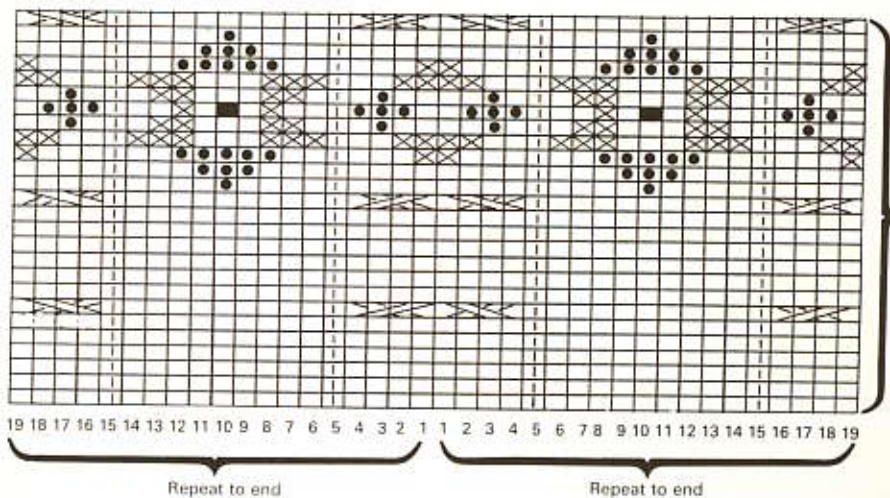

- SWISS DARN
- = col 1
- X = col 2
- = col 3
- = col 4

- = cross sts with left sts over right
- = cross sts with right sts over left
- = drop st and reform as for ribbing



KNITMASTER ^{creative} KONE

2 ply brushed acrylic · Brushed chunky · 4 ply acrylic/wool · Aran

Designer yarn in today's fashion colours



Aneto 2 ply
Blackjack

Aneto 4 ply
Bouclé



**KNITMASTER
KONE YARN**

AVAILABLE FROM YOUR
LOCAL KNITMASTER STOCKIST

KNITMASTER