

instruction manual **Empire** COMPUTAMATIC

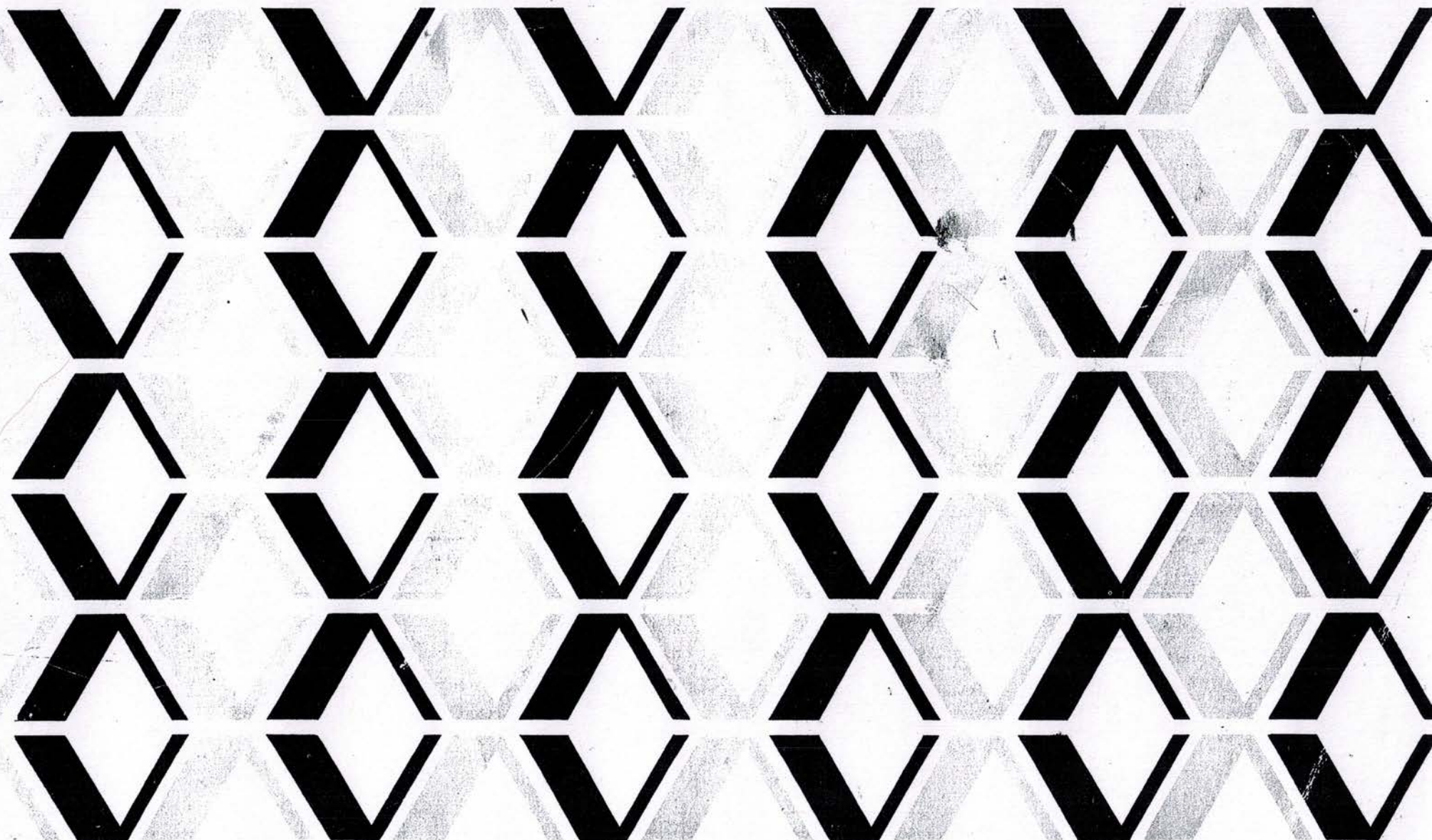

I N D E X

SETTING UP THE KNITTER	1
INFORMATION BEFORE KNITTING.....	6
• Position of needles in the needle-bed	6
• Tension Dial	7
• Pattern Selector Buttons.....	7
• Holding cam lever	8
• Row-Counter	8
PREPARING TO KNIT	9
HOW TO USE THE PATTERN CENTER.....	16
• Needle Selection.....	16
• Needle Selector Buttons and Reverse Lever	17
• Slide Dial and Slide Indicator	18
HOW TO KNIT PATTERN KNITTING	19
1 Holding pattern (1)	21
2 Holding pattern (2)	23
3 Tucking pattern	24
4 Whole tucking pattern	25
5 Holding and Tucking pattern	26
6 Lace like pattern.....	27
7 Multi-color pattern (1)	29
8 Multi-color pattern (2)	30
9 Multi-color pattern (3)	31
10 Zigzag pattern	33
11 Laying-in pattern (1)	34
12 " " (2)	36
13 " " (3)	37
14 " " (4)	38
15 Cable stitch pattern.....	39
16 Ribbing stitch	41
17 Garter stitch pattern	43
18 Tube Knitting.....	45
KNITTING LACE PATTERN USING L CARRIAGE... 46	
1 Preparing to knit.....	46
2 How to use L Carriage.....	47
3 How to knit Lace Pattern	50
Lace Pattern (1)	51
" (2)	52
" (3)	53
" (4)	54
HOW TO KNIT GARMENTS.....	55
Special additions to simplify still further the knitting and finish of a garment	55
1 Partial knitting in plain stitch	59
2 Increasing stitch	60
3 Decreasing stitch	61
4 How to bind off	63
5 How to cast off	64
6 How to bind off one knit on purl rib.....	64
7 Waste knitting	64
8 How to determine the gauge	65
9 Partial knitting with the L carriage.....	65
Troubles and remedies.....	67
When the needle is bent	67
When the carriage is jammed	69
When the L carriage is jammed	71
Care of your knitting machine	72
Oiling and Cleaning	72
Folding up the knitter	74

Carrying Case

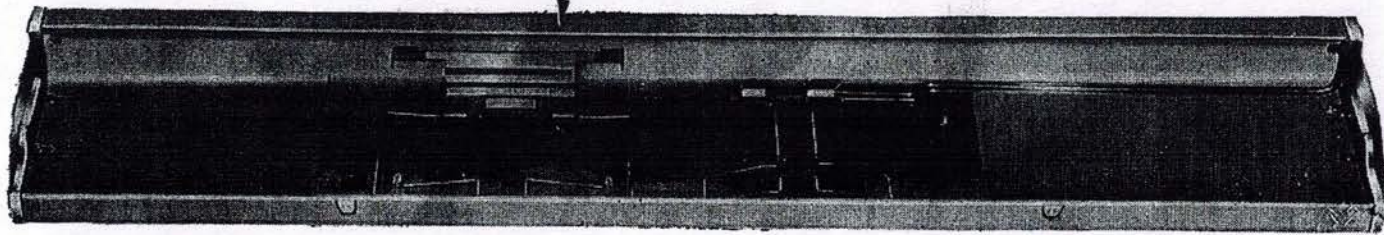

Accessory Tray (Cover of Accessory Box)

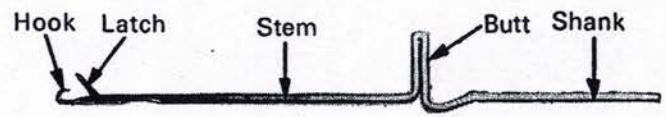
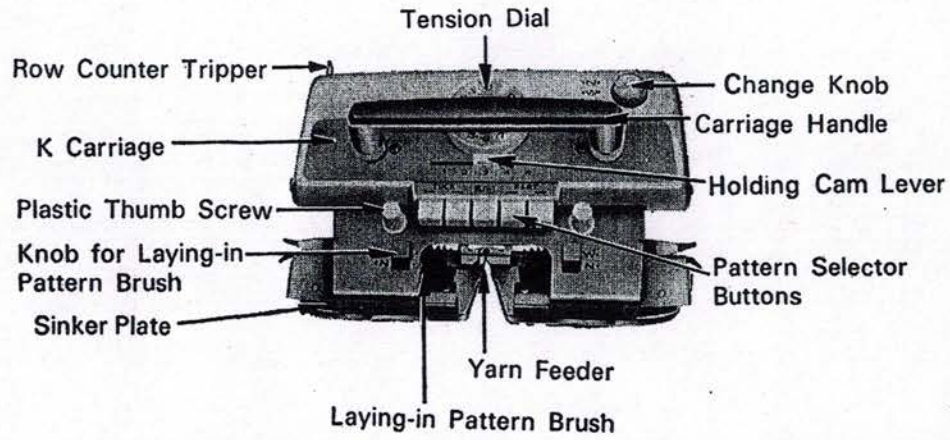
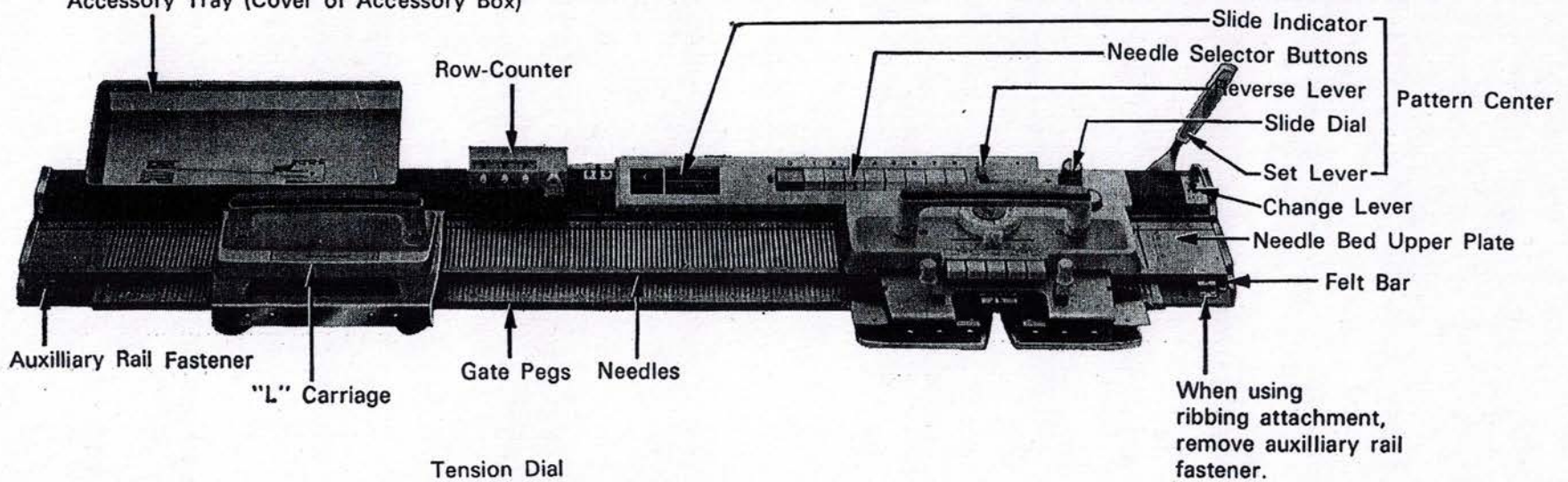



Cast-on Comb, Small

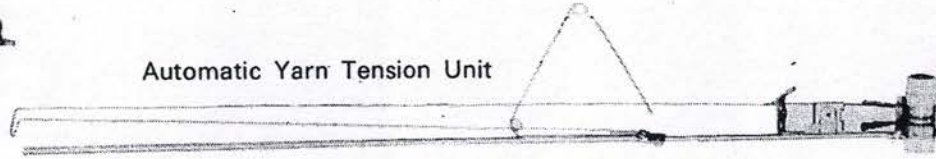

Automatic Yarn Tension Unit

Sinker Plate Assembly



Paraffin

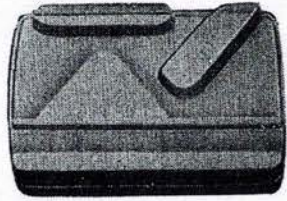

Picker

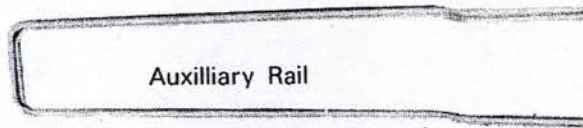

Auxilliary Rail



Cast-on Comb



Set Lever



Hand Brush

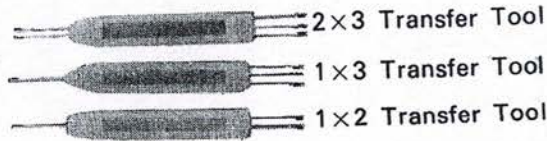

2x3 Transfer Tool

1x3 Transfer Tool

1x2 Transfer Tool



Crochet Needle



Latch Tool



Color Weight

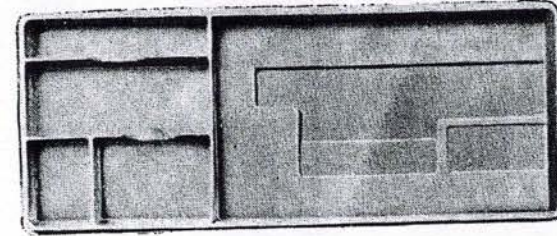

Accessories Box



Oil Bottle



Row-Counter



Accessories Kit

Spare Needles

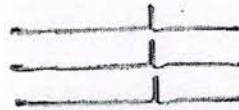

Plastic Case for Spare Needles

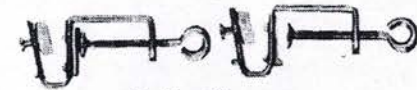

Table Clamps



Carriage Lock



1/2 Needle Pusher

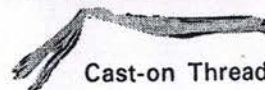

Cast-on Thread



Carriage Handles

SETTING UP THE KNITTER

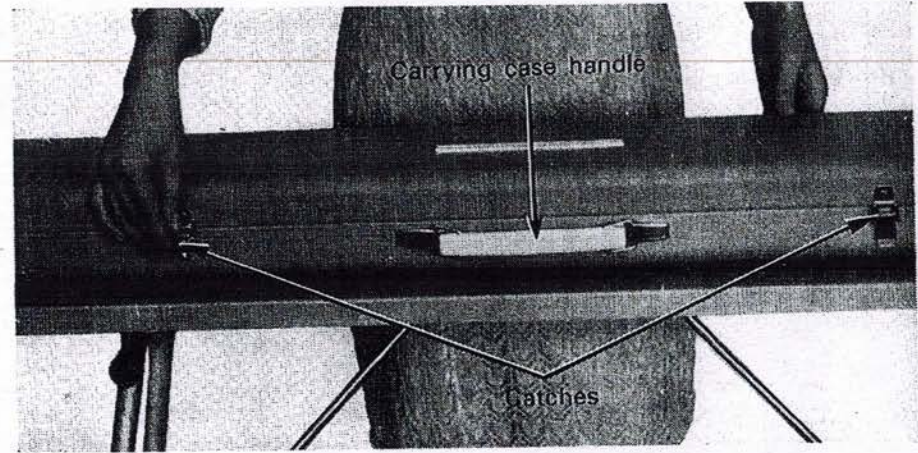
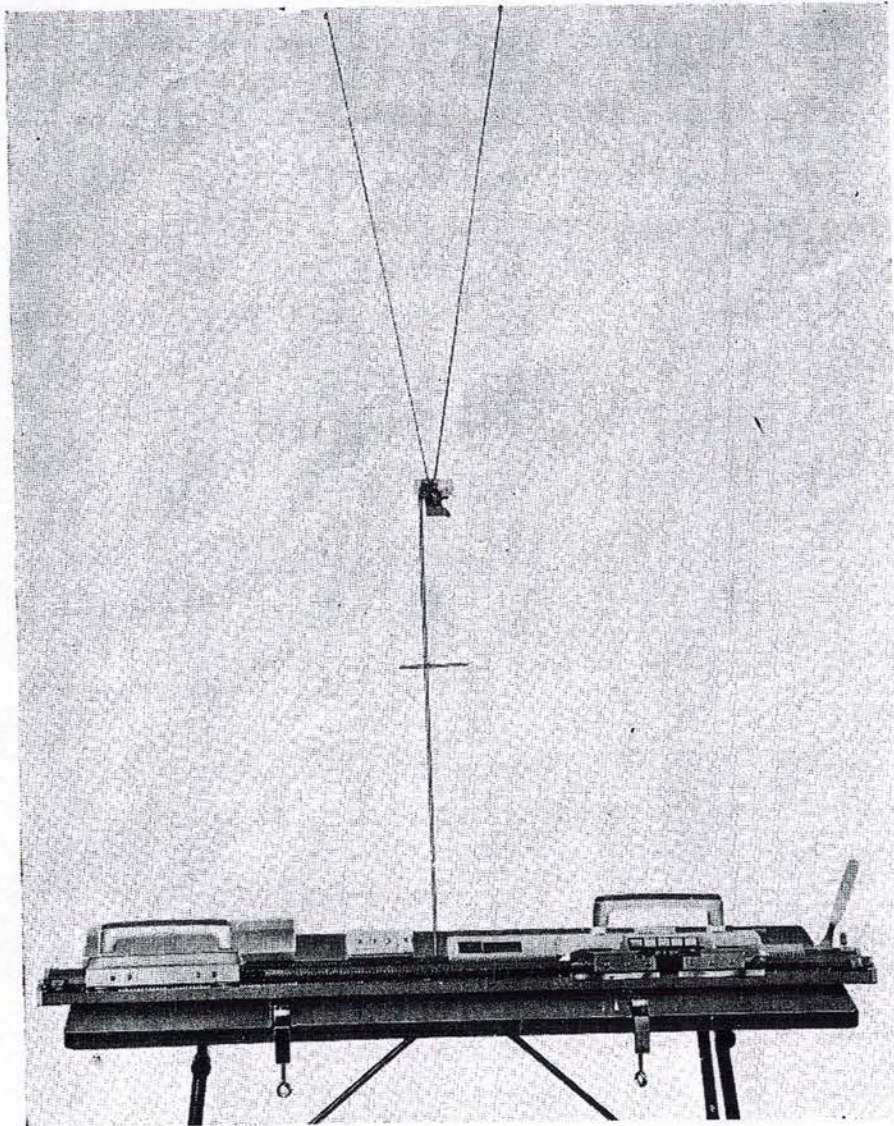

- (1) Place the knitter with the handle of carrying case away from you and unlock the catches on both sides of the handle.

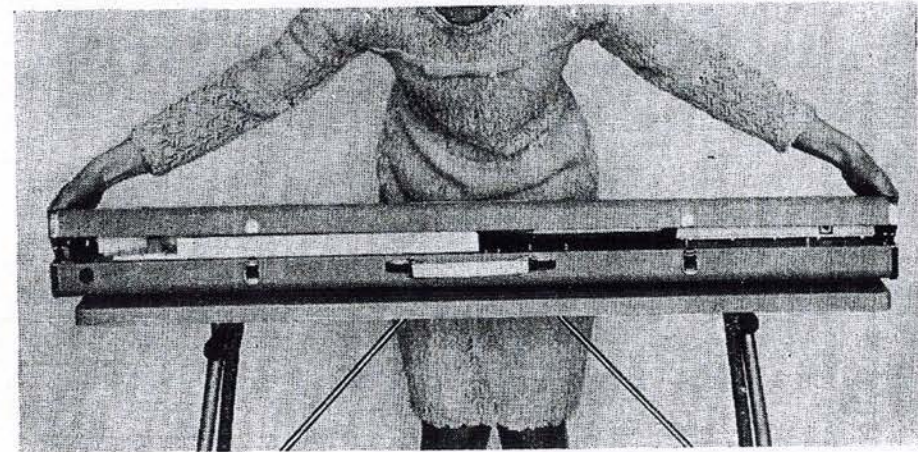

- (2) Lift the upper case slightly and pull towards you, so that the upper case can be released.

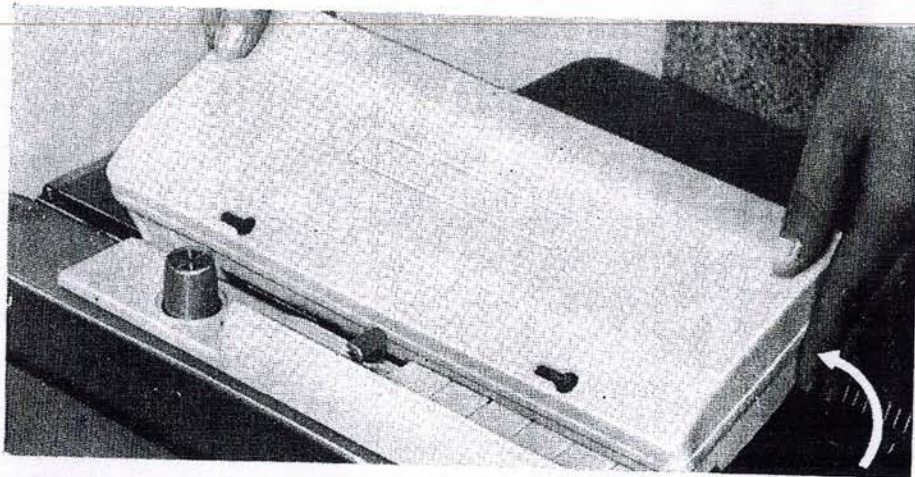

(3) Remove the accessory box on the needle bed.

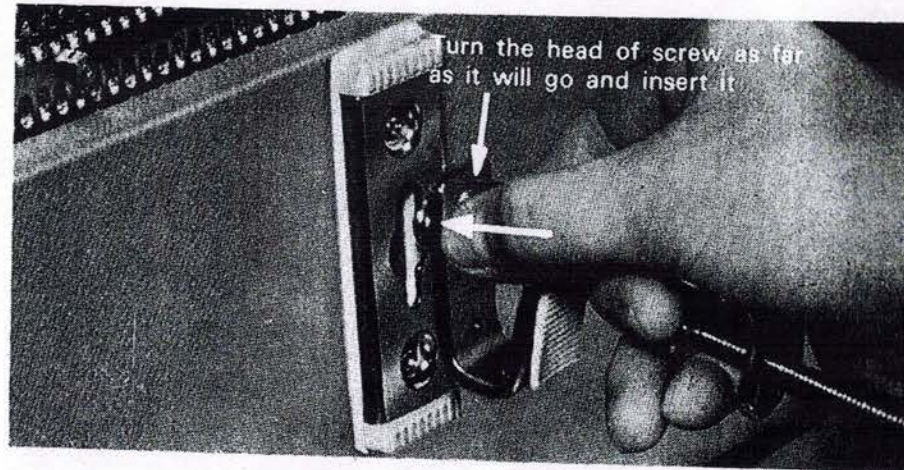

(5) Press the head of screw upwards and fasten the knob.

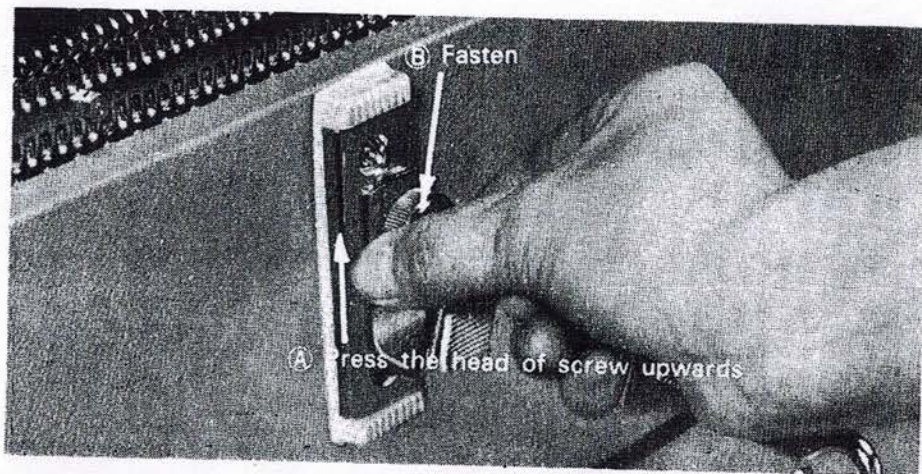

(4) Take the table clamps out of the accessory box. Raise the front of the knitter, insert the head of screw into the aperture.

(6) Fasten the knitter to the table by tightening table clamp screws.

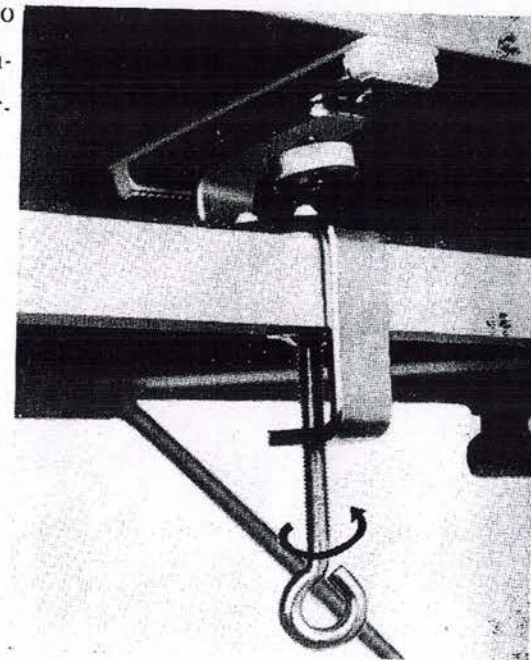

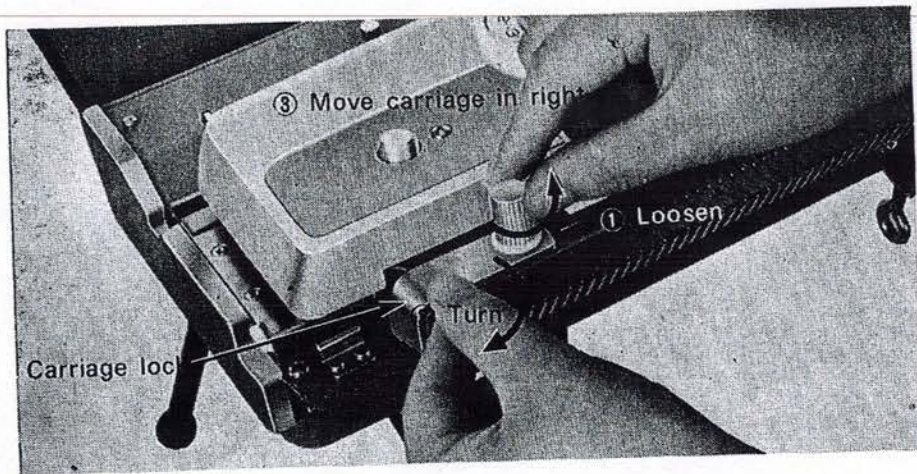

(7) Remove the carriage lock.

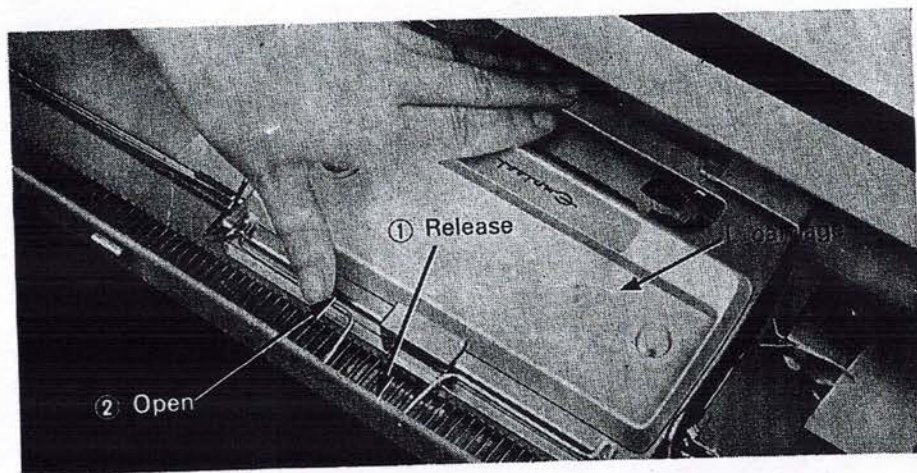

(8) Release the spring in the case and remove the L carriage.

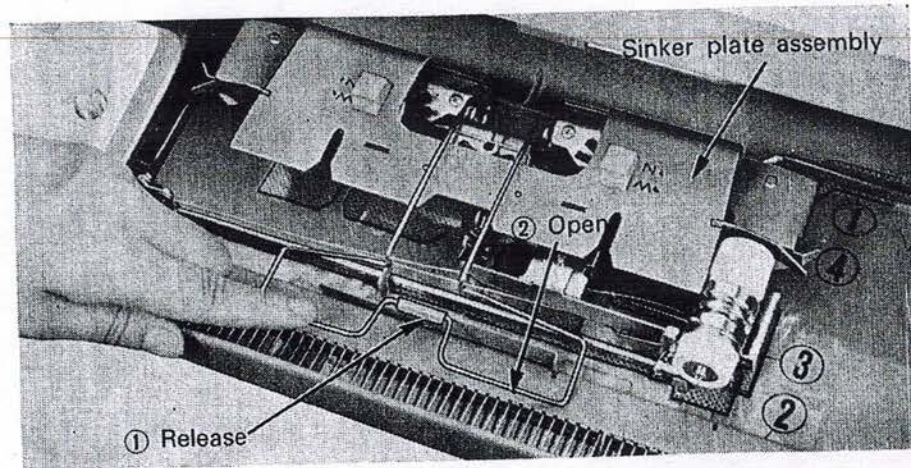

(9) Release the spring in the case and remove the sinker plate assembly.

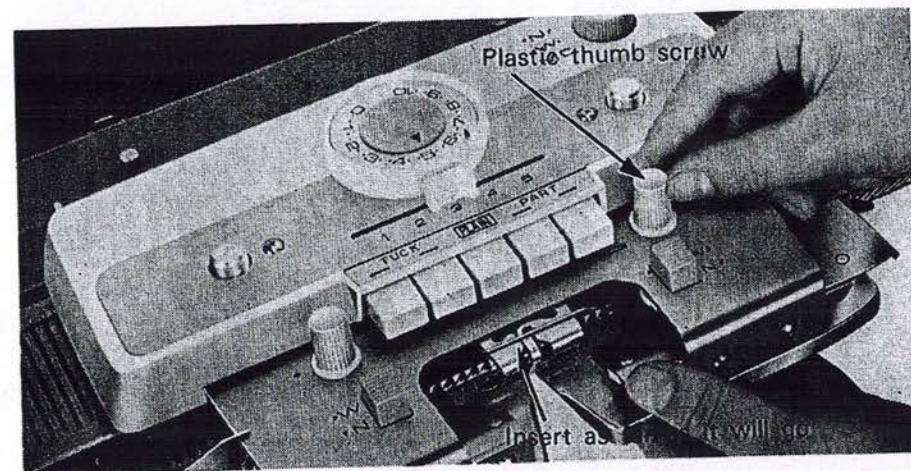

(10) Loosen the plastic thumb screws of carriage, insert the sinker plate assembly as far as it will go and fasten thumb screws securely.

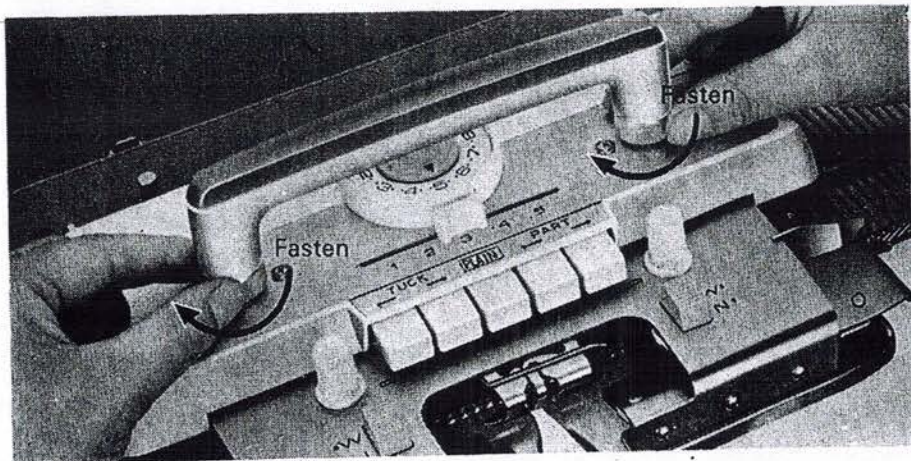

(11) Fasten the handle on the carriage.

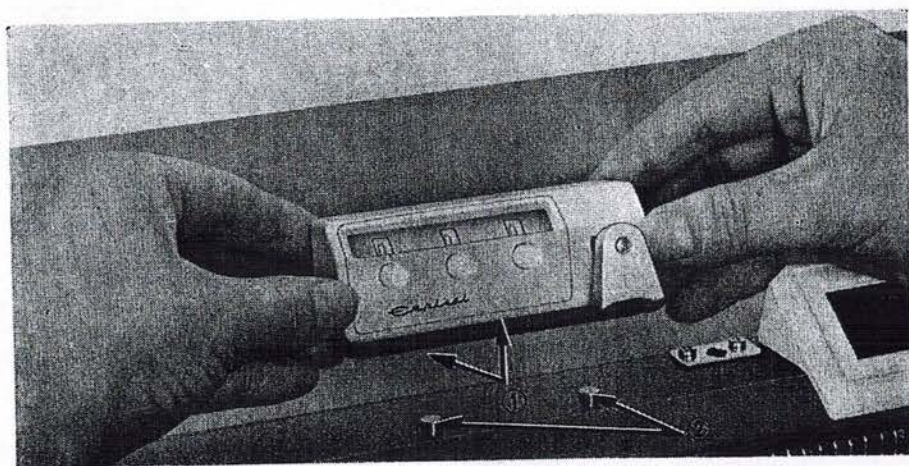

(12) Set the row counter on the row counter setting studs.
(Fit the studs in the apertures of row counter lower

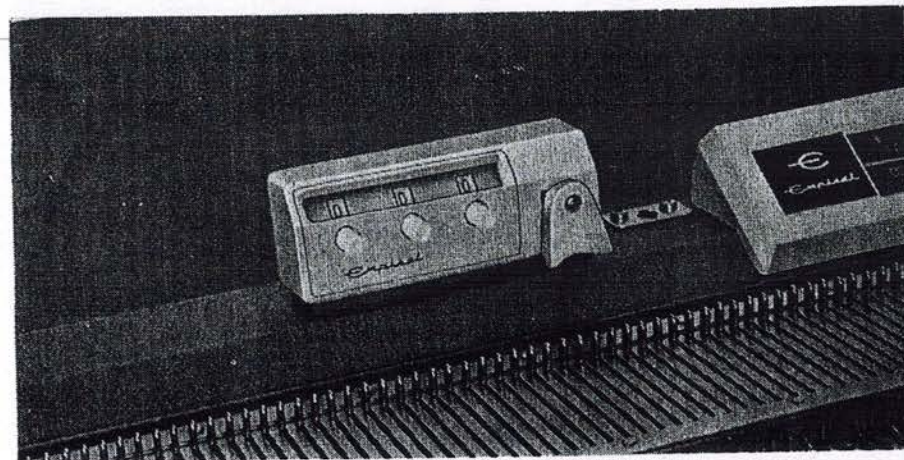

plate, then slide the row counter away from you.)

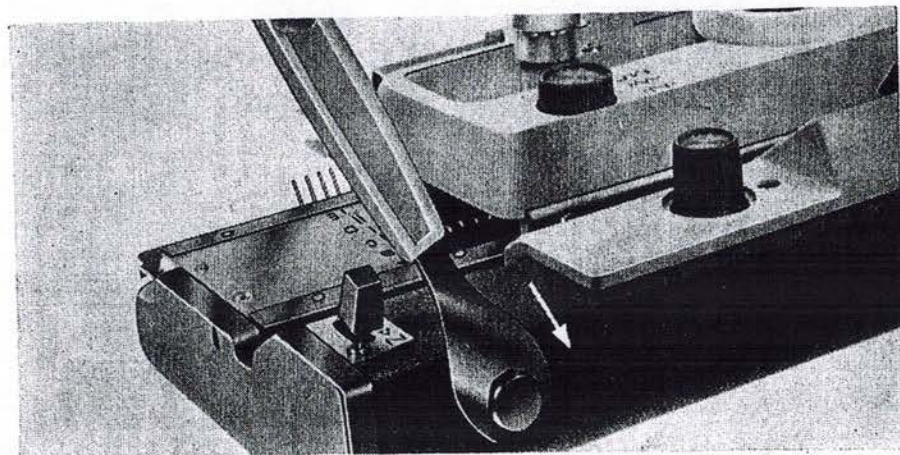

(13) Fit the set lever onto the shaft of the setter at the rear right of the needle bed.

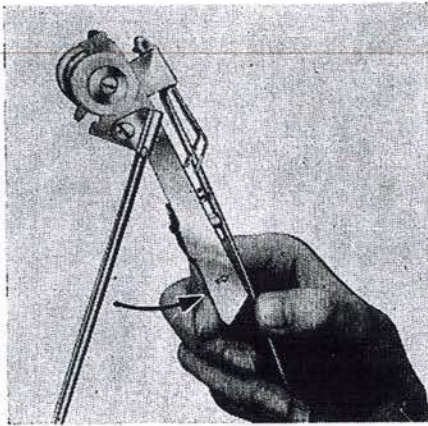

(14) Take out the automatic yarn tension unit from the case and turn the front yarn guide arm in the direction of the red arrow.

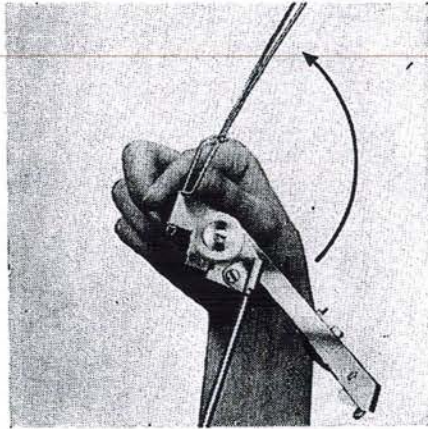

(15) Turn the take up springs as far as they will go.

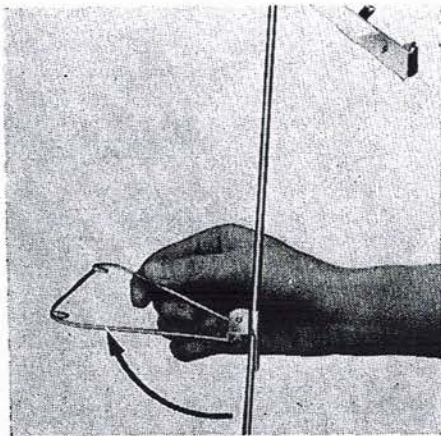

(16) Turn out the rear yarn guide as far as it will go.

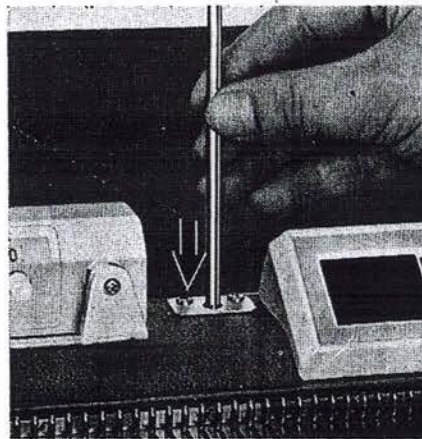

(17) Fit the end of the rod into the stand hole at the center of knitter with the rear yarn guide away from you.

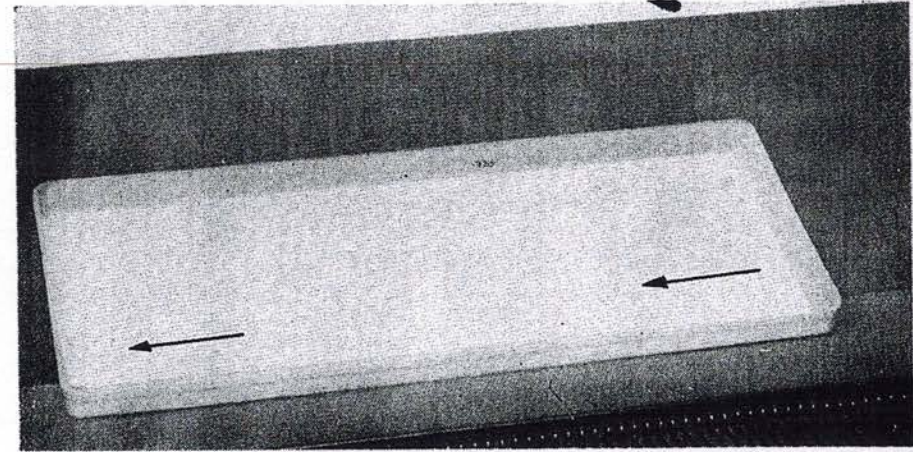

(18) Set the accessory tray (the cover of accessory box) on the accessory tray setting studs.

(Insert the studs in the openings of the accessory tray and slide it to the left as far as it will go.)

INFORMATION BEFORE KNITTING



• Positions of needles in the needle bed

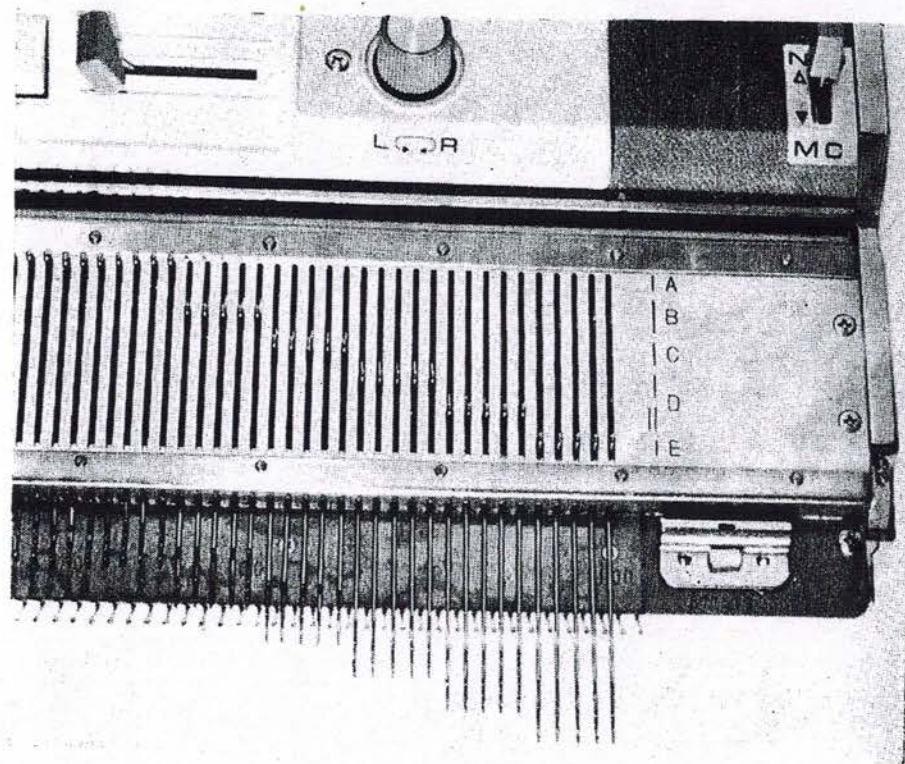

On the both sides of needle bed, there are marks A, B, C, DI, DII and E.

These marks show the positions of needles.

· Tension Dial

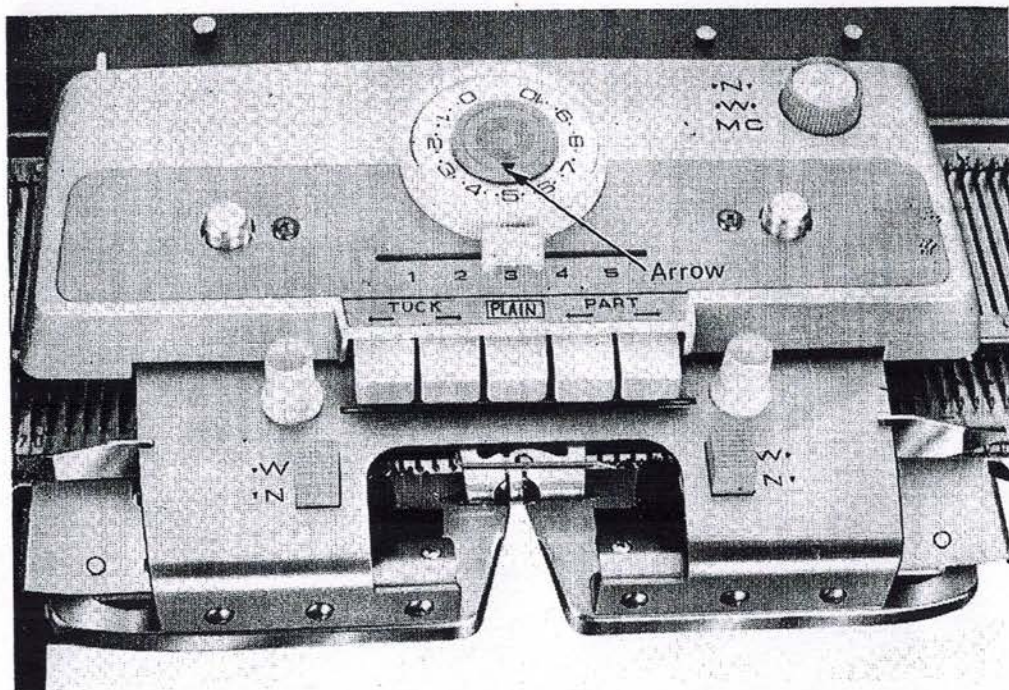

Tension in knitting denotes the size of the stitch. The tension dial is graduated from 0 to 10, each space between numbers being subdivided into three parts. The figure 0 denotes the tightest tension, i. e. the smallest stitch and the 10, the loosest or largest stitch. The tension at which a garment is knitted depends not only on personal taste, but also on the type of garment required and the thickness of the yarn.

· Pattern Selector Buttons

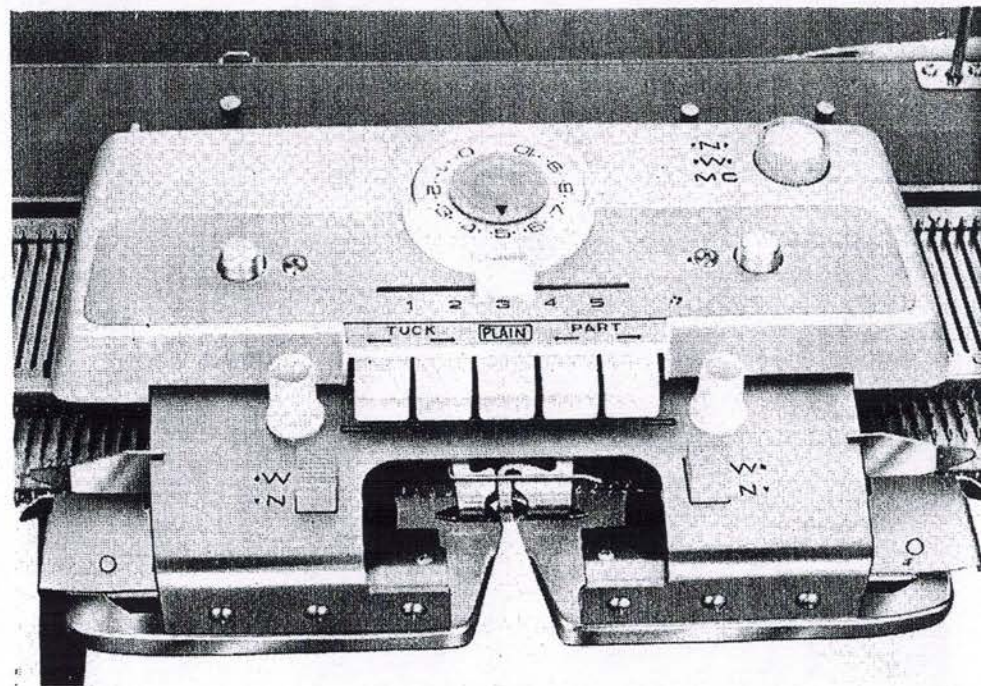

The center button marked "PLAIN", when pushed in, releases other buttons. When all five are even, you get plain knitting (stockinette stitch).

· Holding cam lever

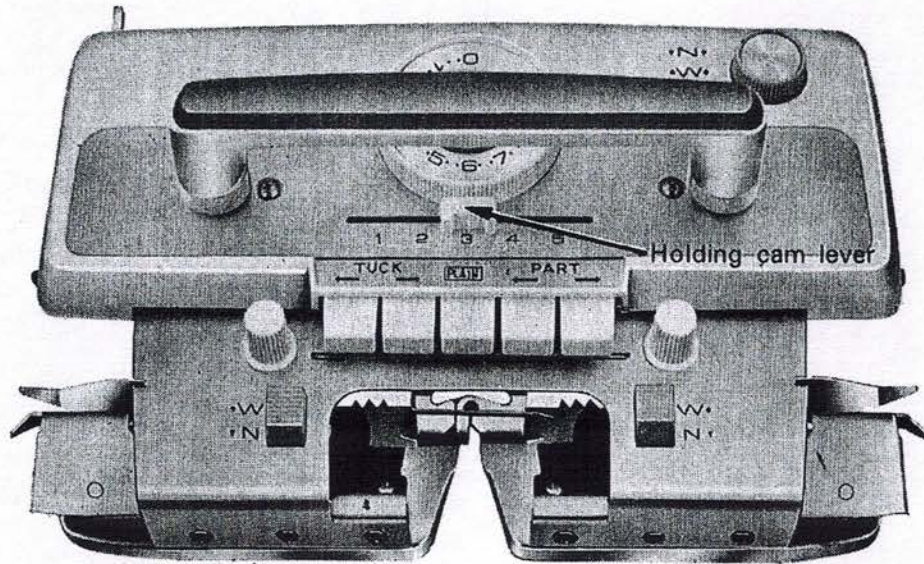

Holding Cam Levers have 5 positions:

- 1 Partial Knitting.
- 2 Holding Knitting.
- 3 Stocking Stitch.
- 4 Holding right to left only.
- 5 Holding left to right only.

· Row Counter

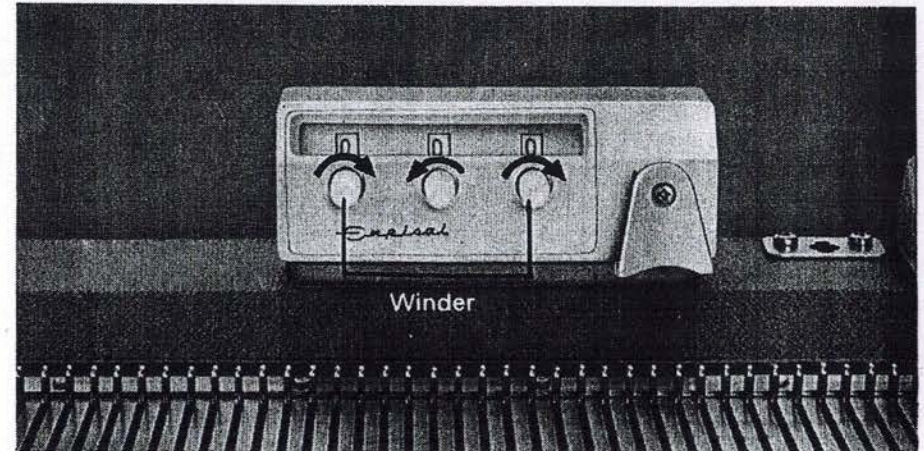

You can turn the figures on the row counter to zero, by turning as indicated by arrows, the 3 knobs in order from right.

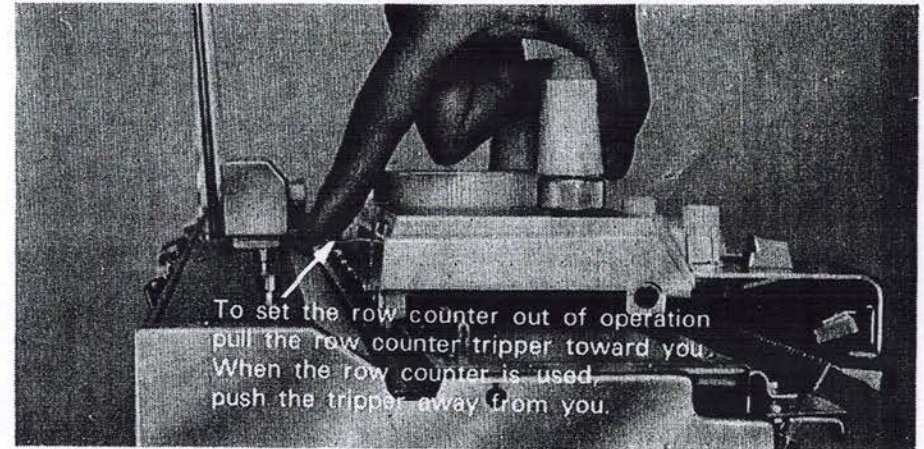

To set the row counter out of operation pull the row counter tripper toward you. When the row counter is used, push the tripper away from you.

PREPARING TO KNIT



- (1) Preparing the yarn
Method ①: Prepare the yarn by piling it loosely into a box or tray in order to prevent the knitting from being uneven.
Method ②: Wind the yarn into ball with "Ball Winder" and "Skein Holder."

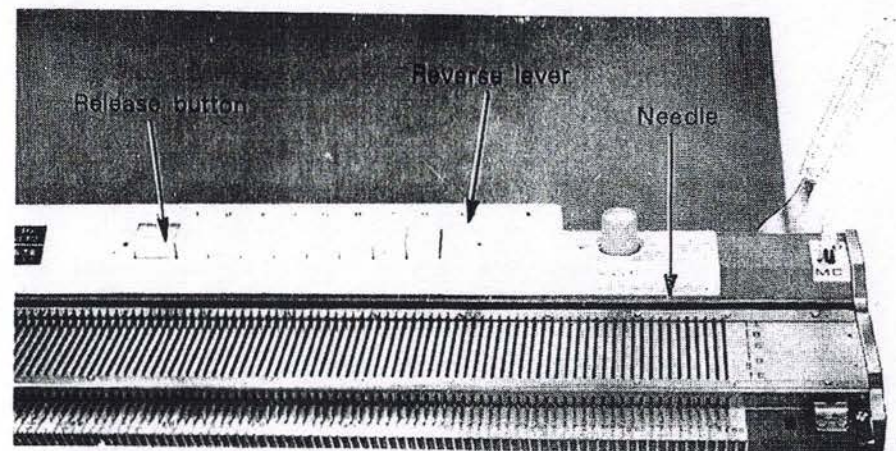
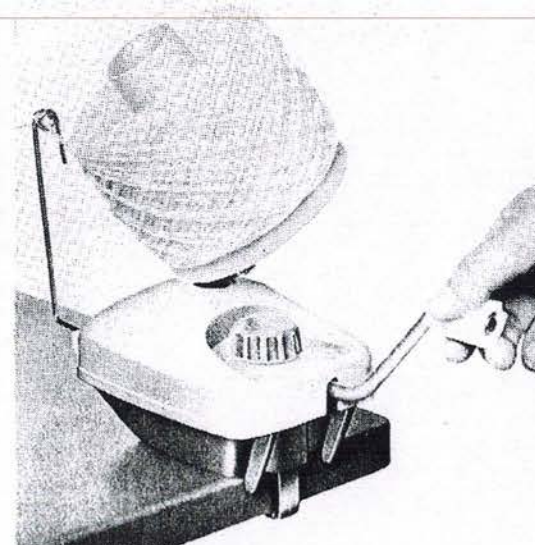

- (2) Push down the release button and set the reverse lever to "1" and push back all needles to position "A".

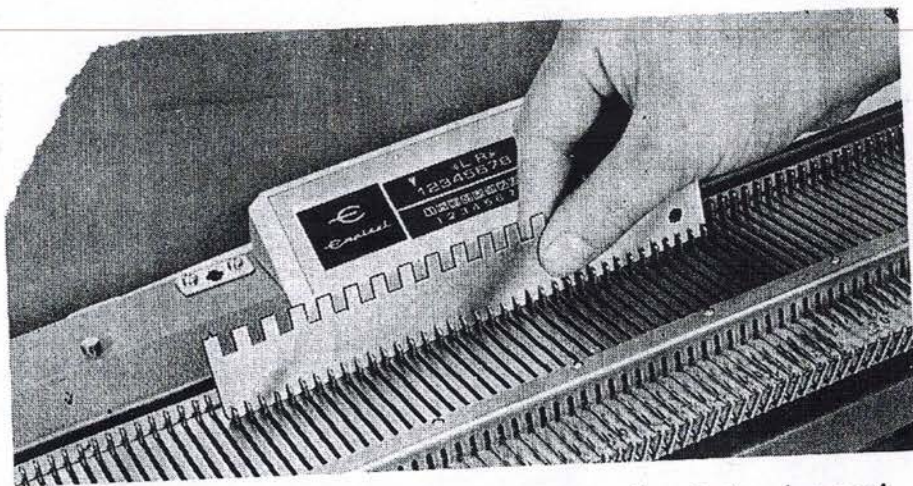

(3) Using the straight edge of a needle pusher, bring forward the desired number of needles to position "B", or about $\frac{1}{2}$ " from the resting position "A".

(4) Set the carriage as follows.

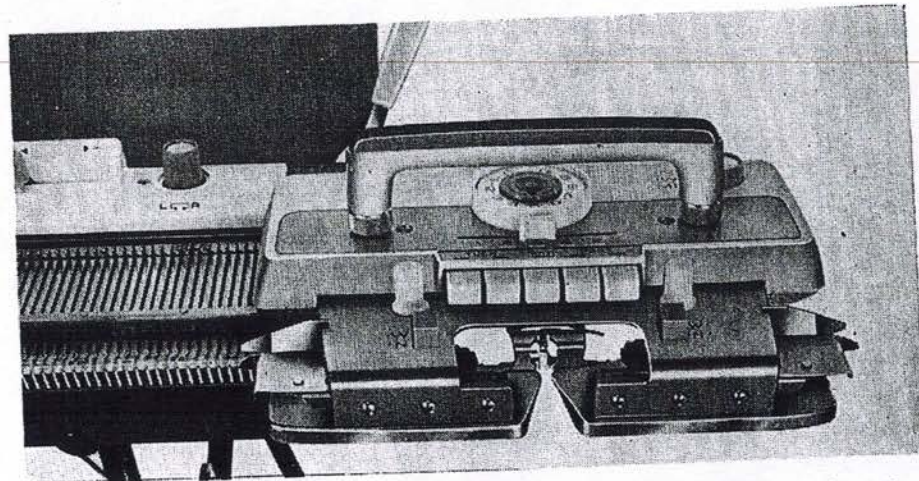
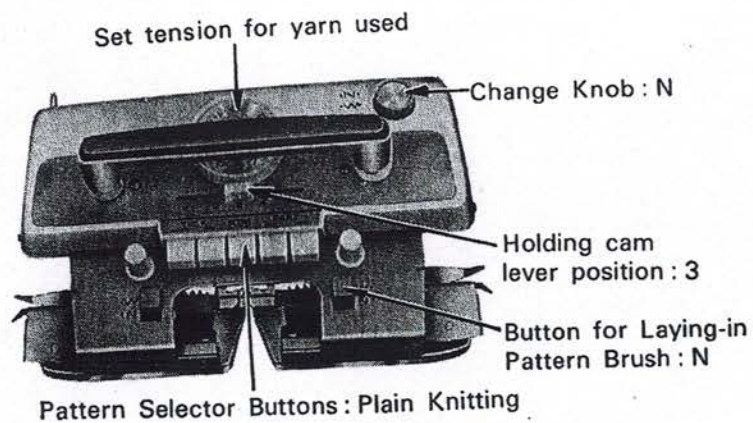

(5) Move the carriage across the working needles and put the carriage on the right end of the needle bed.

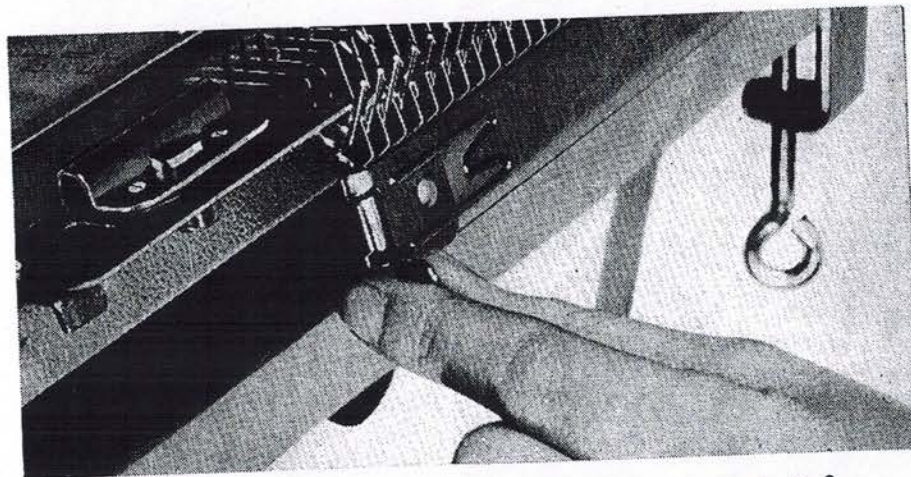

(6) Hold comb centered to the edge of the needle bed with the wire hooks of the comb facing you. Turn securing levers at both ends to face you.

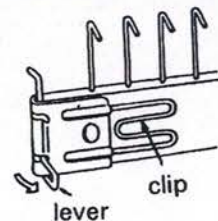

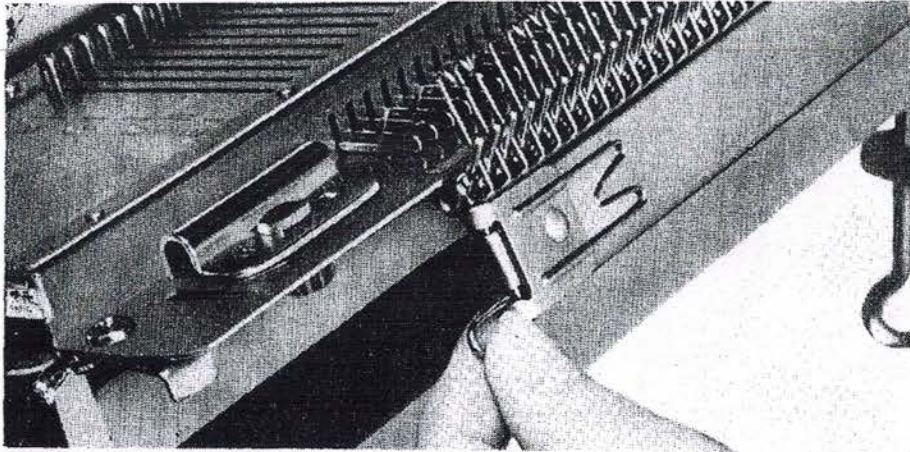

(7) Place hooks between pegs of needle bed as far as possible. Turn the two securing levers outwards to the right and left respectively, and cast-on comb will hang correctly on the machine.

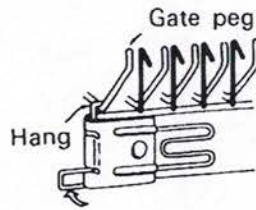

(8) Thread the automatic yarn tension unit.

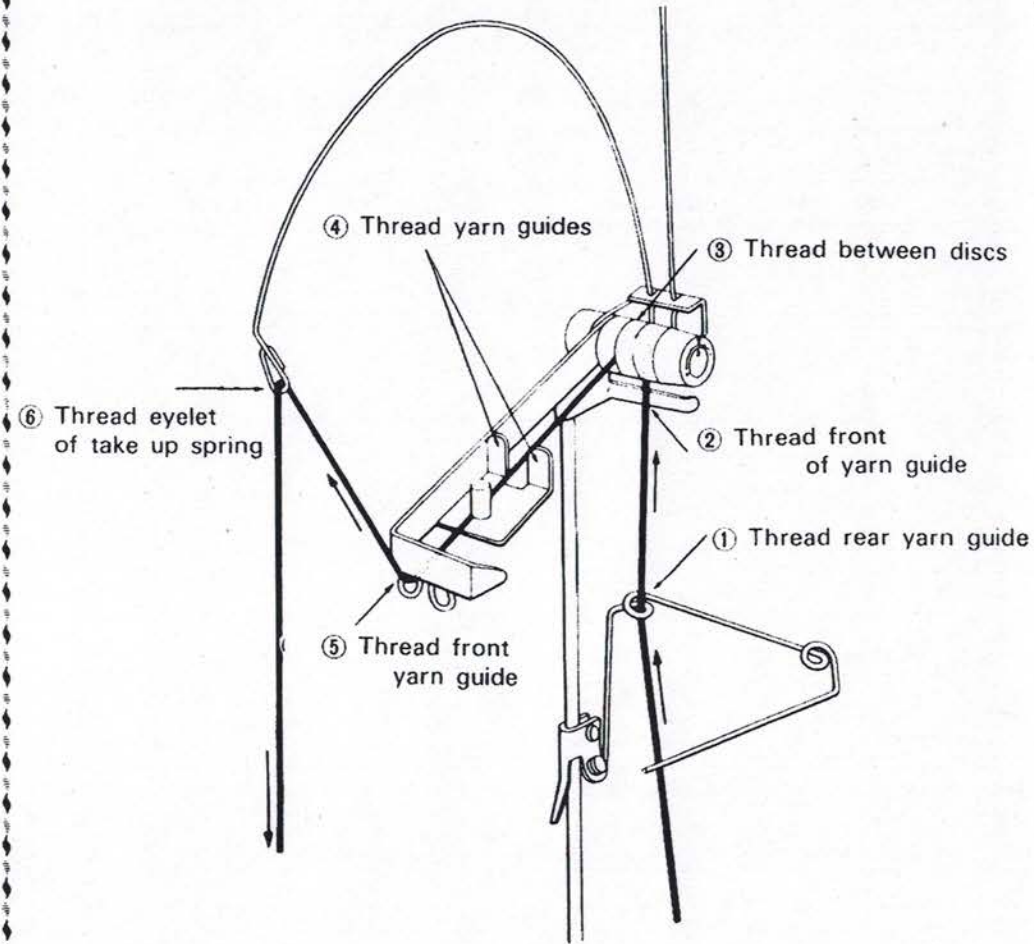

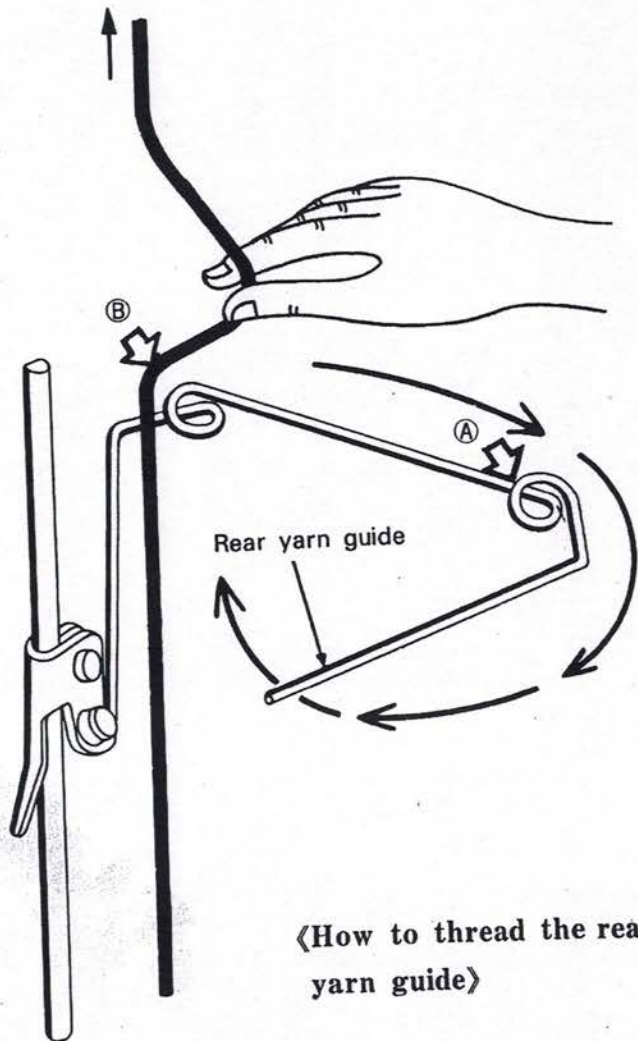

〈How to thread the rear yarn guide〉

Fit paraffin to stud on front yarn guide.

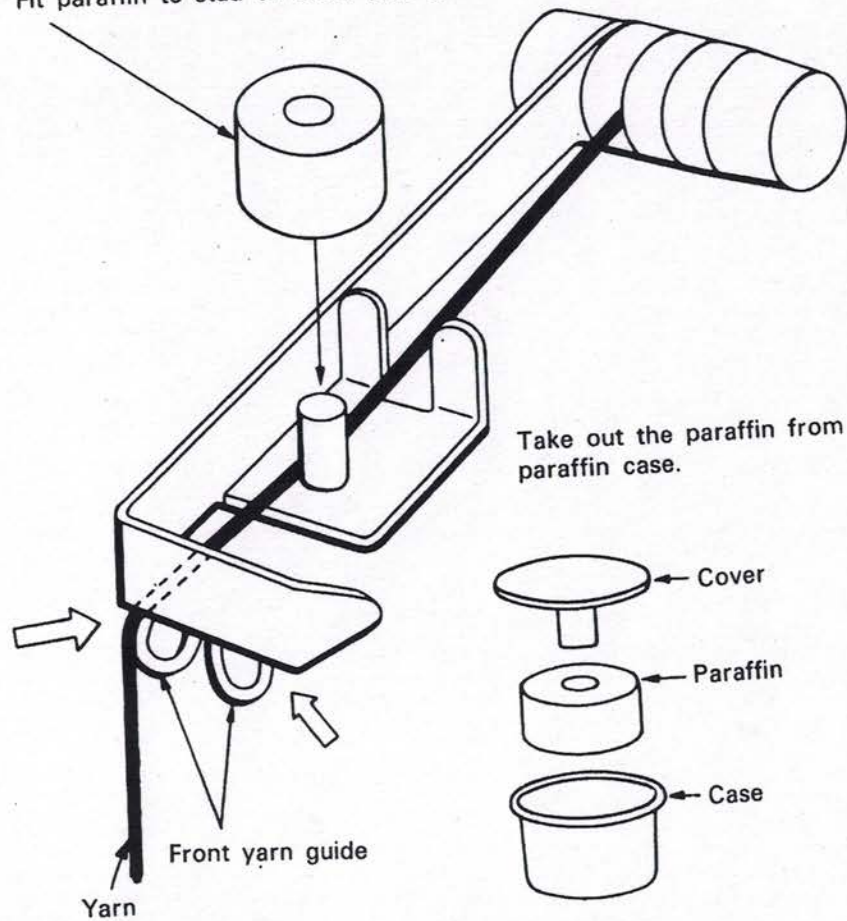

〈How to thread the front yarn guide〉

Thread the yarn through front yarn guide as shown in figure.

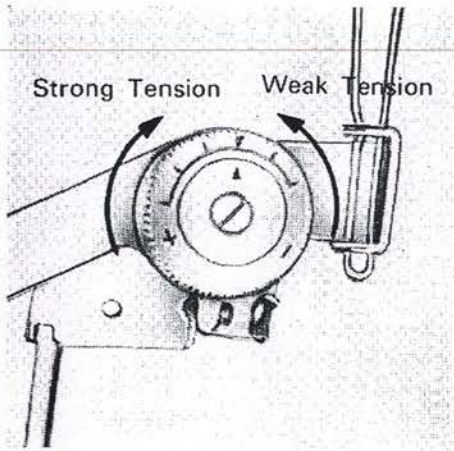

(9) Adjust the locating knob. The locating knob has marks “+” and “-”. “+” denotes strong tension and “-” weak tension. Strong tension is suitable to thin yarn and weak tension is suitable to thick yarn.

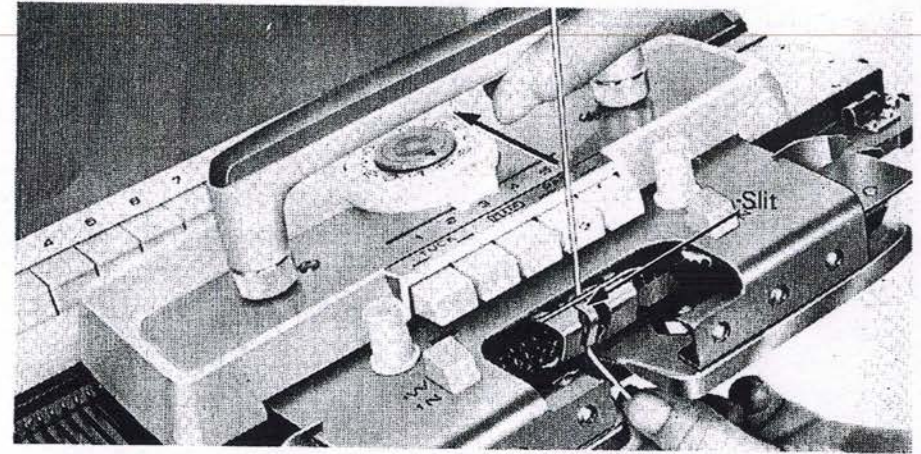

(11) Pull yarn back into slit until you hear the click of the yarn feeder spring.

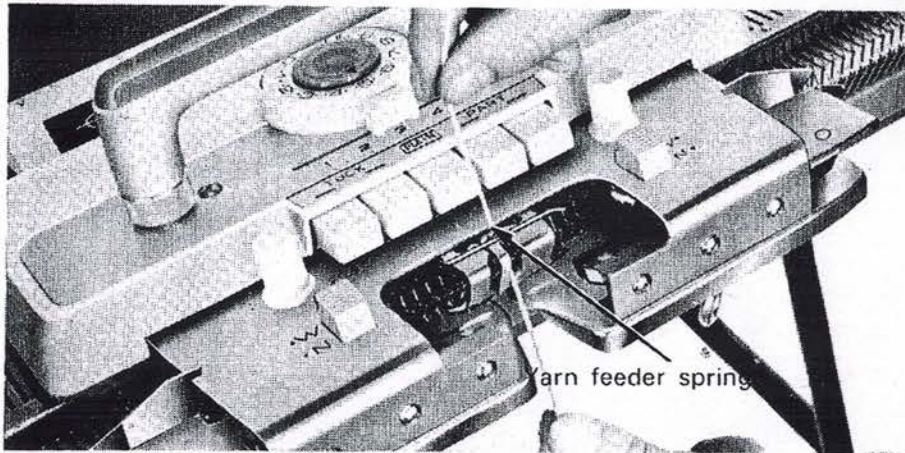

(10) Thread yarn under the yarn feeder spring.

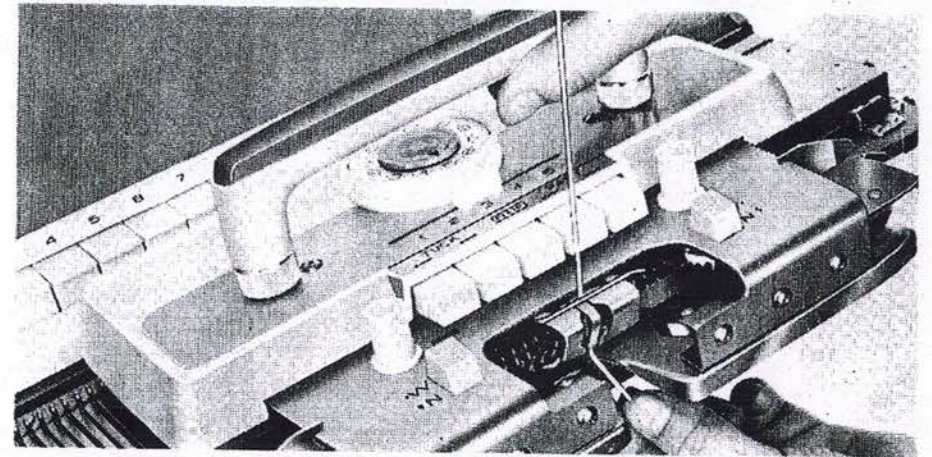

(12) Hold the end of yarn and move the threaded carriage from right to left. This will cause loops to be picked up in the needle hooks.

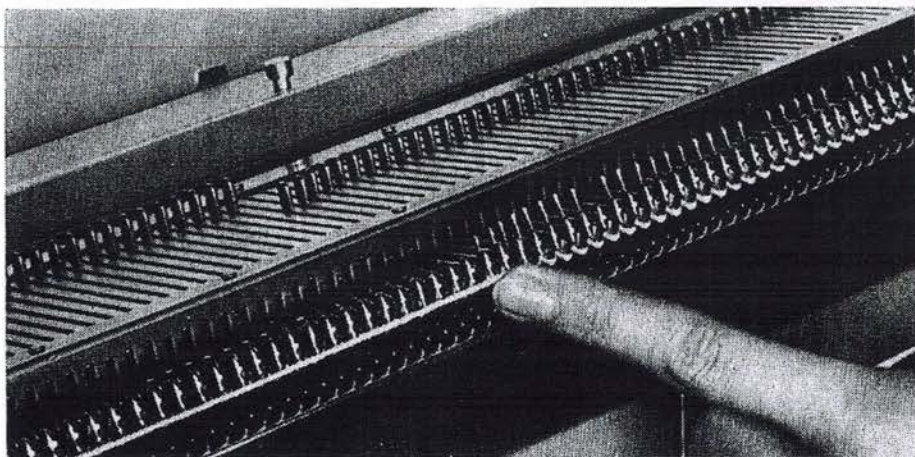

(13) If the last few needles come up from the line of other threaded needles, push them back with fingers. Continue the carriage movement until the carriage is clear of the cast-on comb.

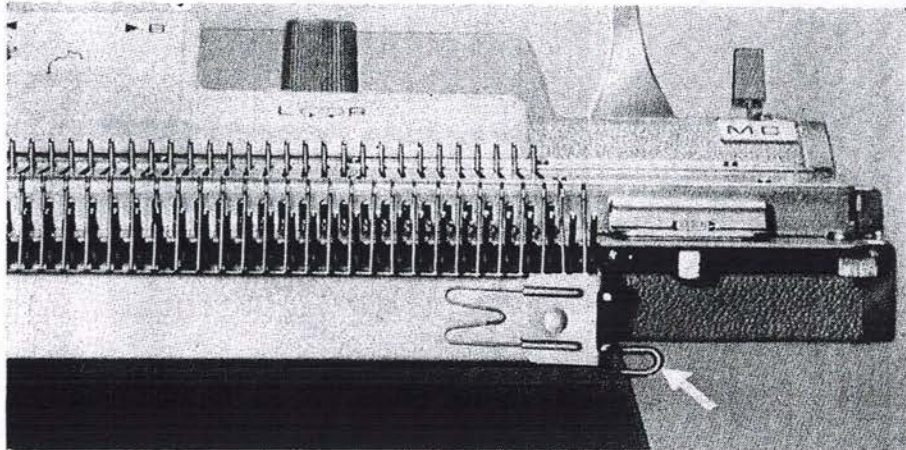

(14) Carefully unhook the comb from the pegs by turning the securing levers of the cast-on comb and let the cast-on comb hang in the loops of yarn.

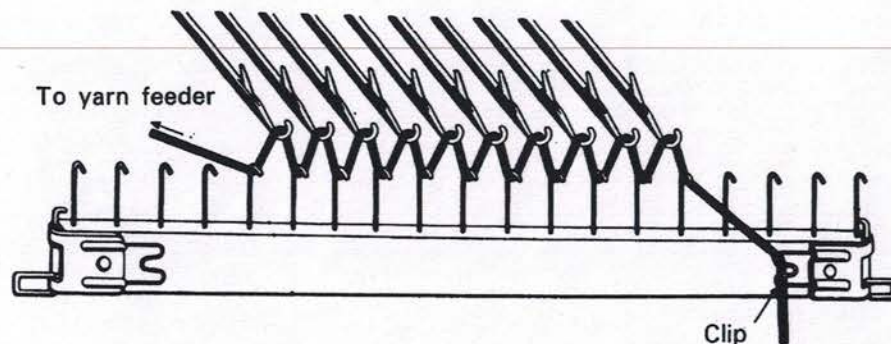

(15) Turn the loose end of the yarn round the cast-on comb clip to keep it out of the way and to secure the first stitch.

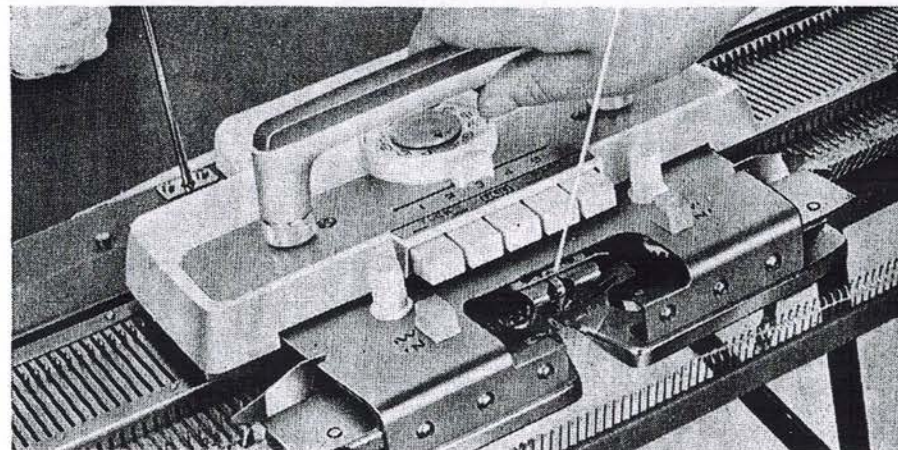

(16) After casting-on, move the carriage from left to right and continue knitting. Move the carriage at an even speed and listen for a click at the end of each row.

If the carriage is jammed in the course of normal knitting, see page 69.

· Knit Stitch and Purl Stitch

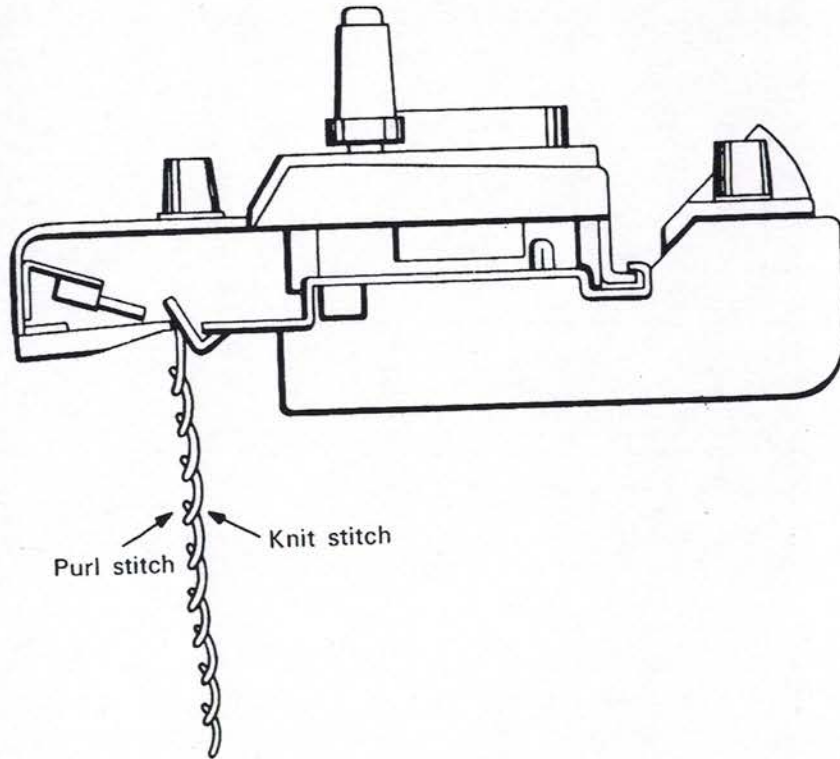

* In knitting, the side of the material which faces you is called the purl stitch, and the other side is called the knit stitch.

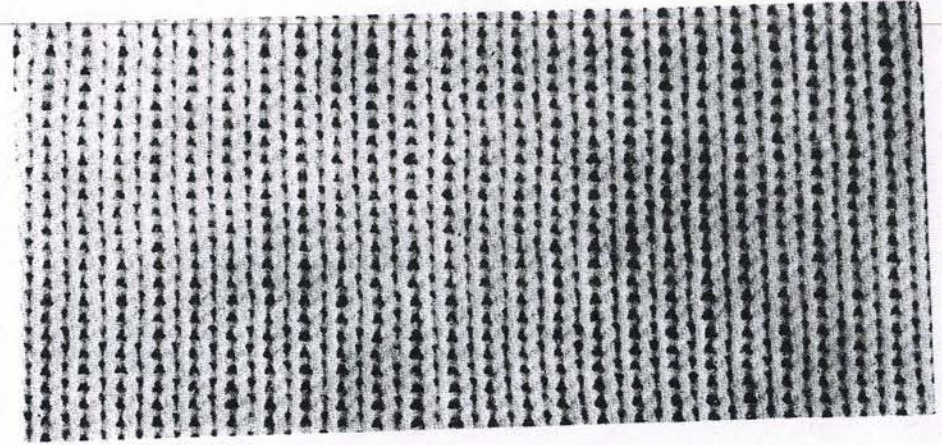

《Knit stitch of plain knitting》

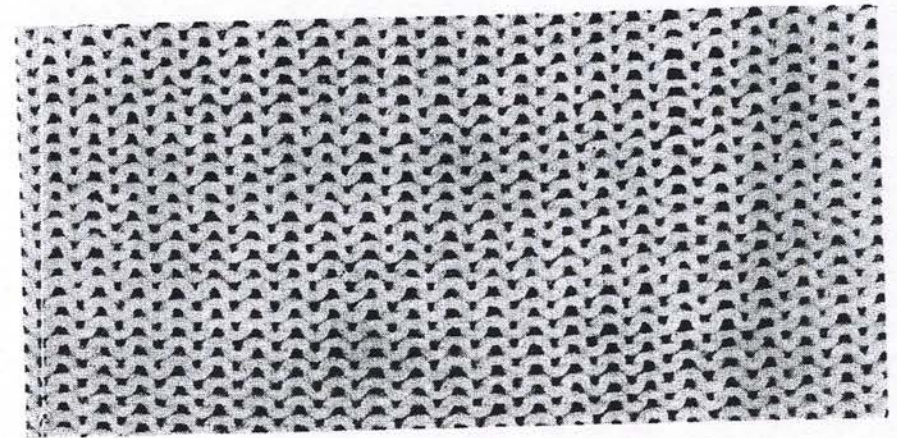

《Purl stitch of plain knitting》

HOW TO USE THE PATTERN CENTER

The pushbutton patterning system is one of the revolutionary features of this knitter. Multicolor and textured designs now can be made automatically and the pushbuttons in conjunction with cams can produce most intricate designs effortlessly.

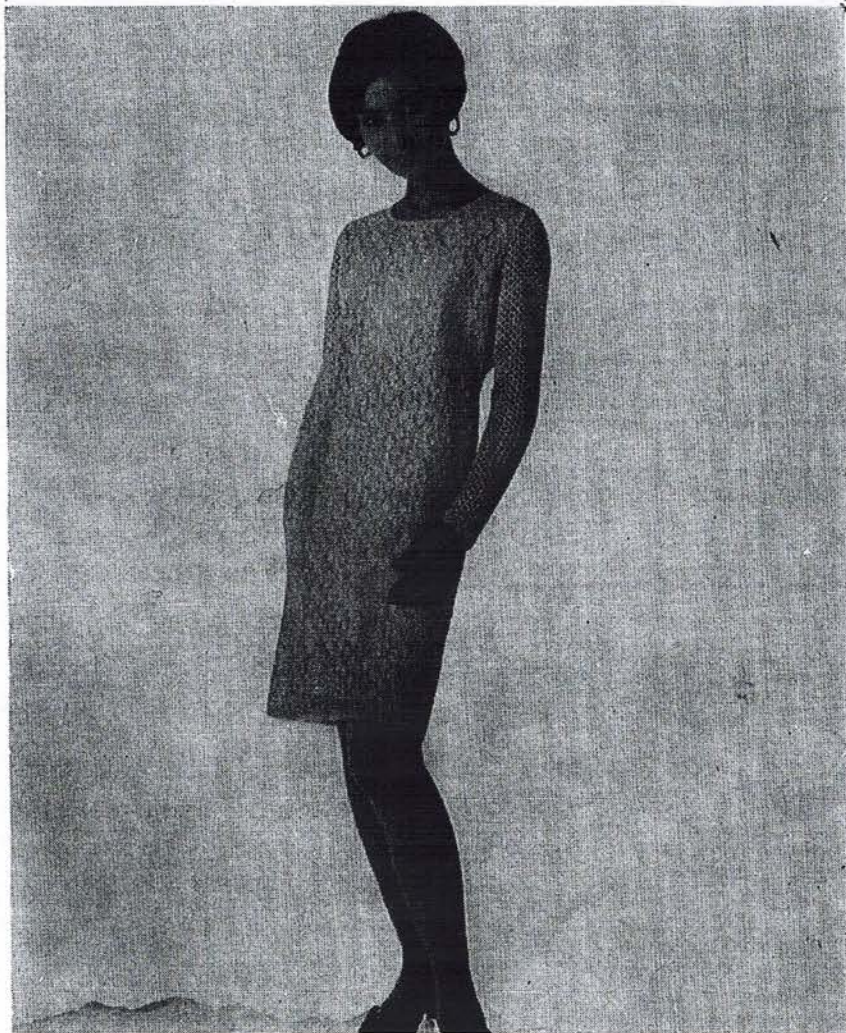

• Needle Selection

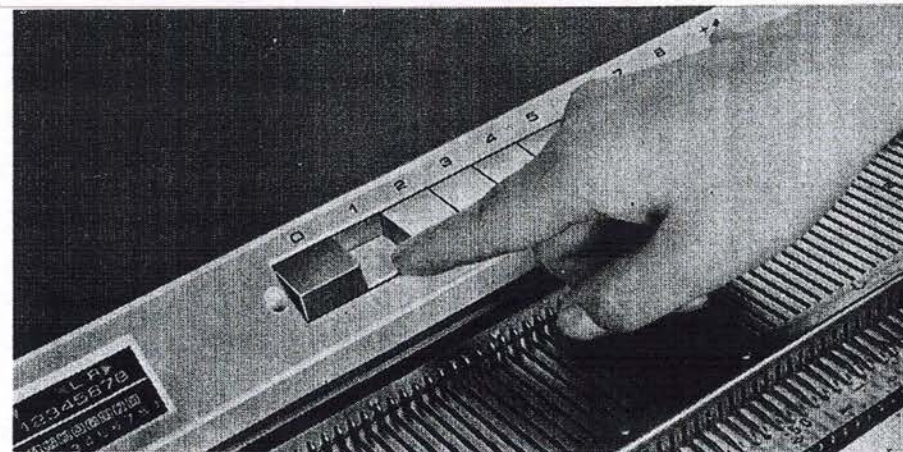

- (1) Raise the desired number of needles from position "A" to position "B".
- (2) Push down the "1" button.

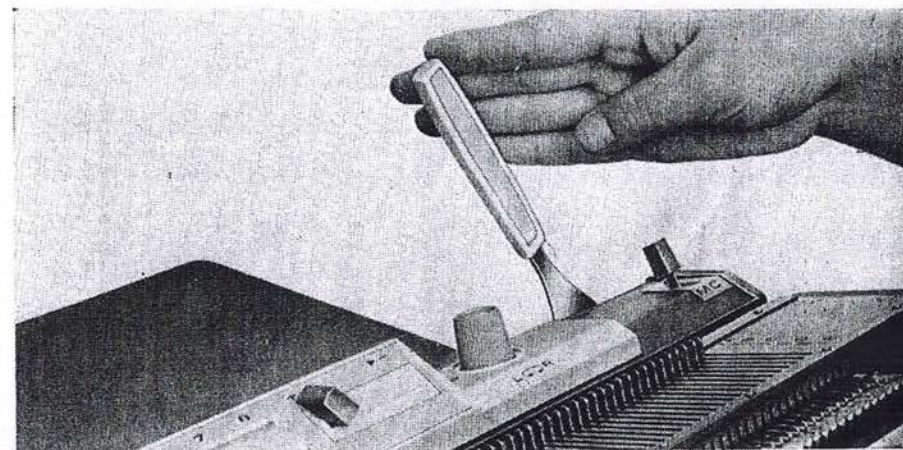

- (3) Turn the set-lever to the left as far as it will go, then the corresponding needles will be raised to position "DI".
- (4) Move the carriage with setting for plain knitting. Then all needles will be back to position "B".

(5) Turn the set lever again so the same needle's group will be raised.

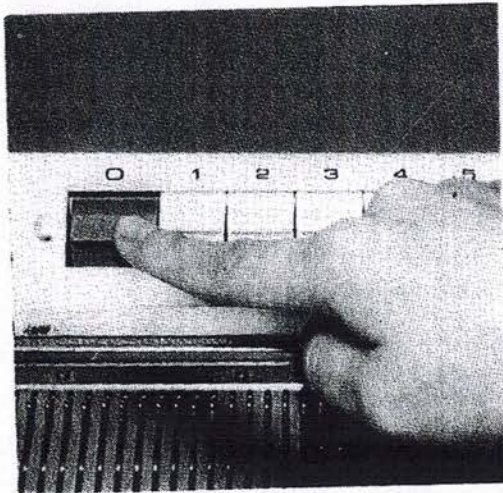

(6) Push down the release button, then the button "1" will be released.

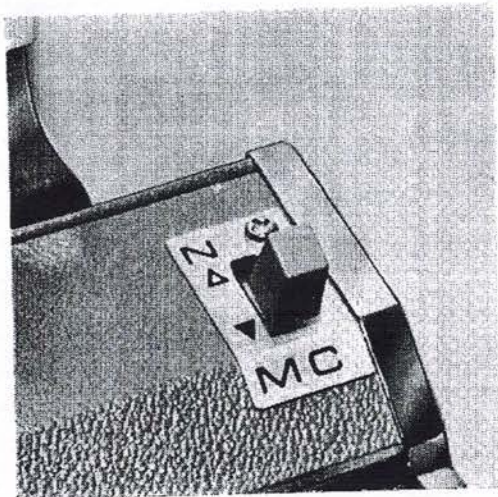

(7) Shift the needle selector lever towards yourself so that when pushing down the set lever, the needles will actuate in a large motion to come to the position of DII. This operation is used for multicolor knitting.

• Needle Selector Buttons and Reverse Lever

* There are eight needle selector buttons.

Each button controls each needle group. A combination of pushed down buttons will control the corresponding combination of selected needles.

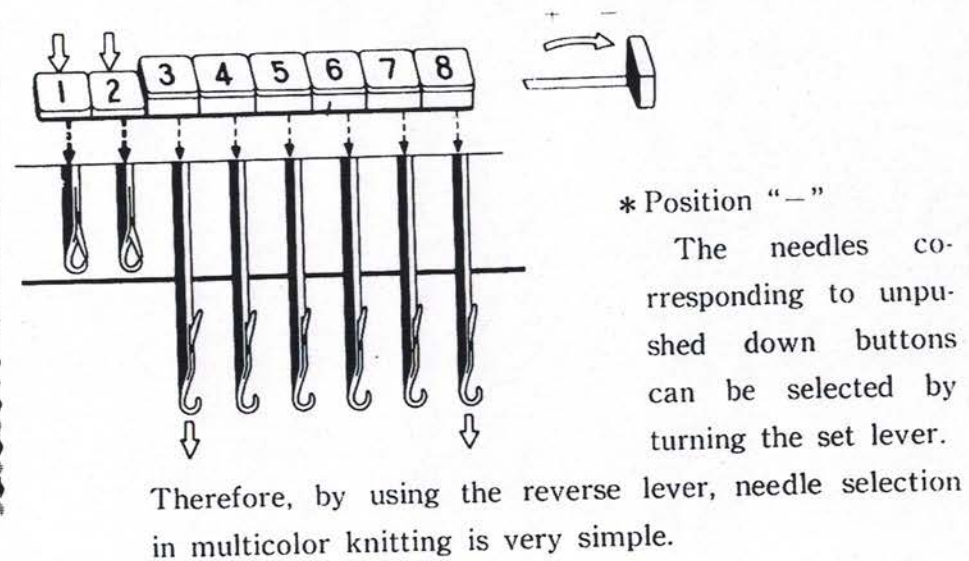
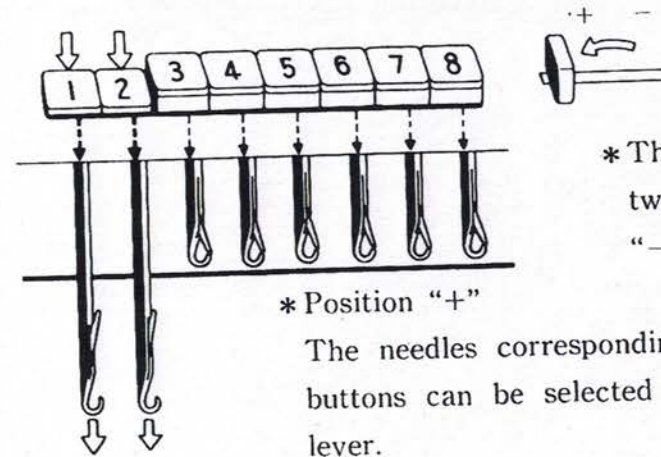

Slide dial and Slide Indicator

- (1) Push down the "1" button, turn the slide dial and set the arrow at 1 on the slide indicator.

Swivel the set lever, then the needles on the mark will be selected.

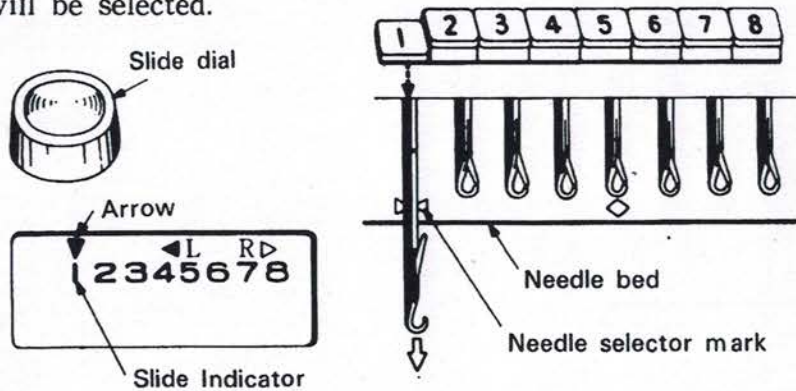

- (2) Turn the slide dial and set the arrow at 2 on the slide indicator.

Turn the set lever, then the needles on right side of the mark \boxtimes will be selected.

The slide direction indicator indicates the direction in which the slide dial is turned.

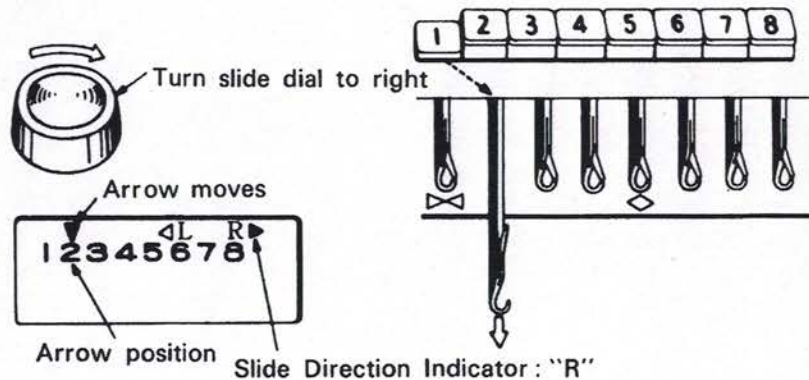

- * The slide dial is used for sliding needle selection position and very useful for zigzag patterns and diagonal patterns.

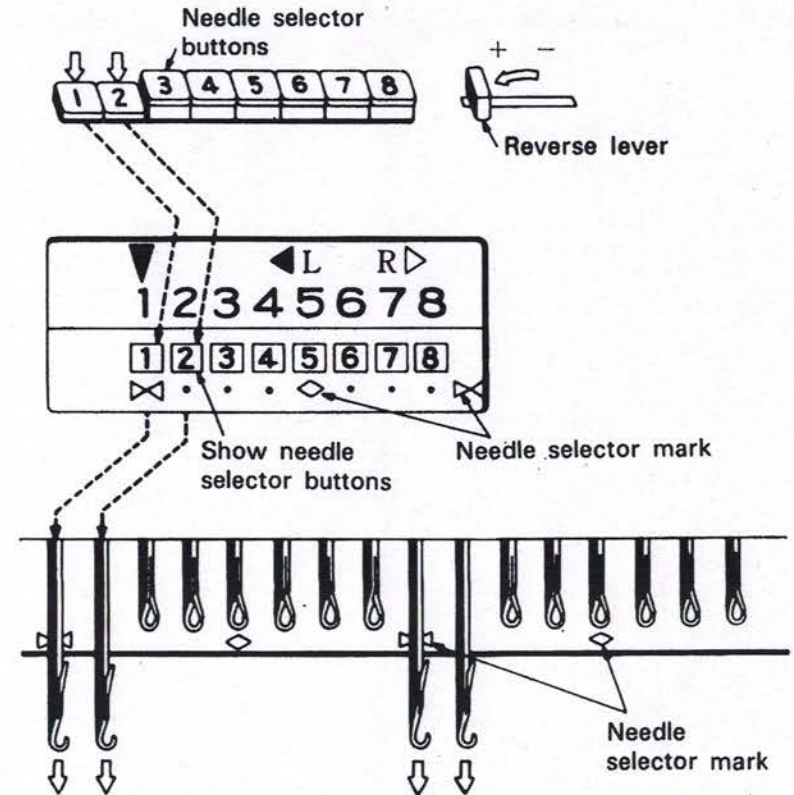

- (3) Relation between the needle selector buttons and the needles are shown in above figure.

• Steps:

Operate the knitter in numerical order.

The required operation in each step is shown in the lateral rows of the table.

• Direction of carriage movement:

Move the carriage according to the direction of arrow.

Before step 1, place the carriage on the right side of the needle bed.

• Color of yarn:

Shows the color of yarn in the yarn feeder.

Main Color: a

Sub Color : b.c

Figure "○" means the movement of the carriage without knitting.

• Tension Dial:

Shows the tension No. of the Dial.

The numerals show tension for medium size yarn.

• Holding Cam Lever:

Shift the holding cam lever to the marked position.

• Pattern selector button:

Press the button corresponding to the designated mark.

• Change knob:

Turn this knob to corresponding position of the marks: N, W and MC.

• Button for Laying-in Pattern Brush:

Place this button to corresponding position of the marks.

Needle Selector Buttons

1~8 :

Shows the button to be pushed down and operation of the set lever.

a) 5 means pushing down button "5" and operation of the set lever.

b) ■ means operation of the set lever without repushing down of button.

• Reverse lever:

Shift the reverse lever to the corresponding mark.

• Slide dial:

Turn the slide dial to set the scale at this figure.

• Change lever:

Shift this lever to the marked position.

• Laying-in thread:

Shows the color of the laying-in thread.

• Direction of L-Carriage:

Slide the L-carriage to the marked direction.

• Direction of K-Carriage:

Slide the K-carriage to the marked direction. The mark of "→" means one-way travel and the mark of "↻" means the round travel of the carriage. Before knitting, position the K-carriage at the right end of the knitting material.

How to knit the holding pattern (1).

It is not necessary to change the yarn, pattern selector button and reverse knob.

Knit several rows of plain knitting and rest the carriage on the right side of the needle bed apart from knitting.

Step 1.

color of yarn : main color
tension dial : 5
holding cam lever : 2
pattern selector button : plain
change knob : Set the knob at the position of "N".
button for laying-in pattern brush : Set the button
at the position of "N".
needle selector button : 1, 5
reverse knob : +
slide dial : 1
change lever : Set the lever at the mark of "△".

After setting as above, swivel set lever and move the carriage from right to left.

Step 2.

Move the carriage to right.

Step 3.

Move the carriage to left.

Step 4.

Move the carriage to right.

Step 5.

Change the holding cam lever from 2 to 3 and move the carriage to left.

Step 6.

Move the carriage to right.

Step 7.

Turn the slide dial and set the arrow to 3 on the slide indicator.

Swivel the set lever.

Change the holding cam lever from 3 to 2.

Move the carriage to left.

Step 8.

Move the carriage to right.

Step 9.

Move the carriage to left.

Step 10.

Move the carriage to right.

Step 11.

Change the holding cam lever from 2 to 3 and move the carriage to left.

Step 12.

Move the carriage to right.

Repeat steps (1) ~ (12).

5. Holding and tucking pattern

2	"	"	"			"	"	"						"	"	"			→
1	a	7				4	N	N	1	3	5	7	+	1	△				←
Steps	Color of Yarn	Tension Dial	<div style="display: flex; justify-content: space-around; border: 1px solid black; padding: 2px;"> TUCK PLAIN PART </div>			Holding Cam Lever	Change Knob	Button For Laying-in Pattern Brush	<div style="display: flex; justify-content: space-between; border: 1px solid black; padding: 2px;"> 12345678 </div>								Laying-in Thread	Direction of L Carriage	Direction of K Carriage
	Pattern Selector Buttons	Needle Selector Buttons	Reverse Lever	Slide Dial	Change Lever														
Carriage						Pattern Center													



Multicolor Patterns Knitting

Multicolor pattern knitting is efficiently and concurrently done by this knitter as follows:

- (1) After several rows of plain knitting, stop the carriage on the left side once.
- (2) Turn to set the change knob at the MC position and, at the same time, slide the carriage to the right, so that the knitting needles will come on to the position of DI.
- (3) Push the both PART Buttons of the pattern selector button of the carriage, then knit in accordance with the pattern knitting table.

* Be sure to lay across the thread on the open latches of the needles from the carriage side first.

* Open all the latches when laying the thread across the needles. The closed latches cause dropping the stitches.

* The laying thread should be held as tight as it will not be loose.

* Shift the change lever to the mark of "△" when finished patterning.

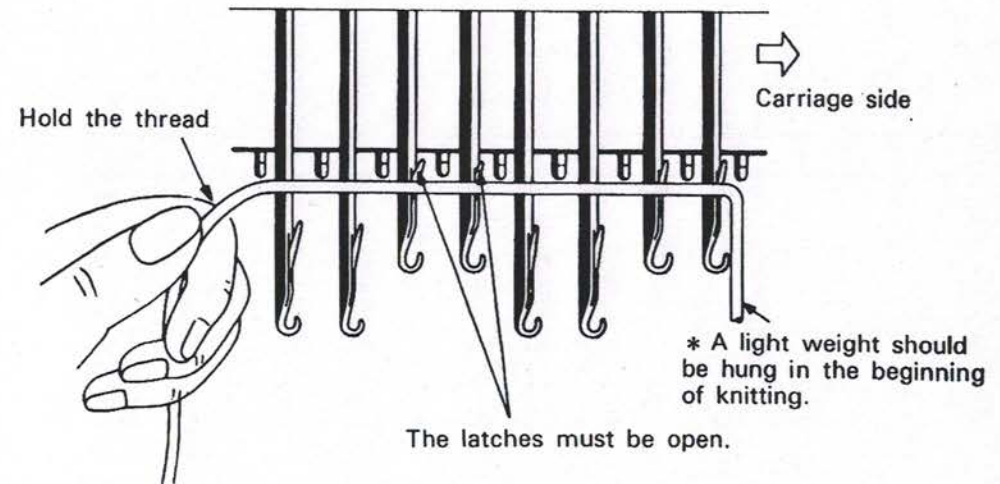

7. Multicolor pattern (1)

8	"	"			"	"	"	"	"					"	"	"	"	→		
7	"	"			"	"	"	"	"					"	"	"	"	←		
6	"	"			"	"	"	"	"					"	"	"	"	→		
5	"	"			"	"	"	"	"					-	"	"	"	←		
4	"	"			"	"	"	"	"					"	"	"	"	→		
3	"	"			"	"	"	"	"					"	"	"	"	←		
2	"	"			"	"	"	"	"					"	"	"	"	→		
1	a	7								3	MC	N	1	2			5	6	+ 1 ▼ b	←
Steps	Color of Yarn	Tension Dial	TUCK PLAIN PART		Holding Cam Lever	Change Knob	Button For Laying-in Pattern Brush	1 2 3 4 5 6 7 8								Laying-in Thread	Direction of L Carriage	Direction of K Carriage		
	Pattern Selector Buttons		Needle Selector Buttons Reverse Lever Slide Dial Change Lever																	
Carriage										Pattern Center										



8. Multicolor pattern (2)

8	"	"				"	"	"	"	"				4	5	6			"	"	"	"		→
7	"	"				"	"	"	"	"			3	4		6	7		"	"	"	"		←
6	"	"				"	"	"	"	"		2	3		5		7	8	"	"	"	"		→
5	"	"				"	"	"	"	"	1	2		4	5	6		8	"	"	"	"		←
4	"	"				"	"	"	"	"		2	3		5		7	8	"	"	"	"		→
3	"	"				"	"	"	"	"			3	4		6	7		"	"	"	"		←
2	"	"				"	"	"	"	"				4	5	6			"	"	"	"		→
1	a	7								3	MC	N	1			5			+	1	▼	b		←
Steps	Color of Yarn	Tension Dial	<input type="checkbox"/> TUCK <input type="checkbox"/> PLAIN <input type="checkbox"/> PART			Holding Cam Lever	Change Knob	Button For Laying-in Pattern Brush	<input type="checkbox"/> Needle Selector <input type="checkbox"/> Buttons Reverse Lever Slide Dial Change Lever								Laying-in Thread	Direction of L Carriage	Direction of K Carriage					
	Carriage							Pattern Center																



How to change the yarn for color knitting pattern

Thread two yarn in automatic yarn tension unit. Thread the knitting yarn through the yarn feeder and hold other yarn with the yarn clip.

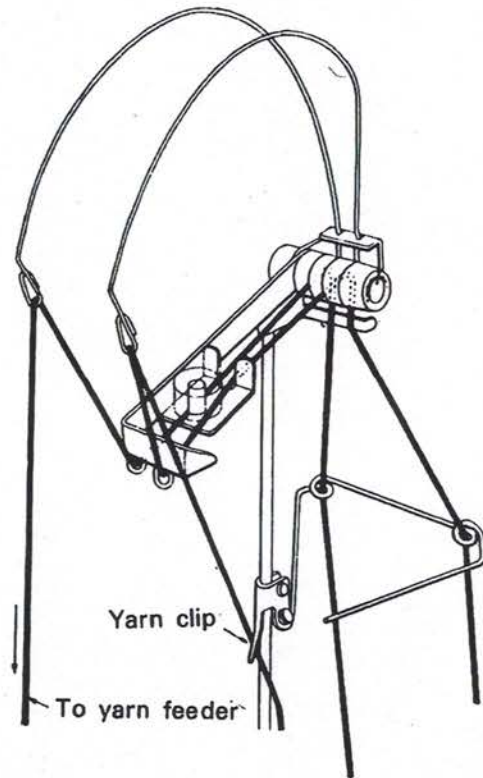

How to change the yarn.

Take off the yarn from yarn feeder and hang it on the end of needle bed.

Thread other yarn through the yarn feeder.

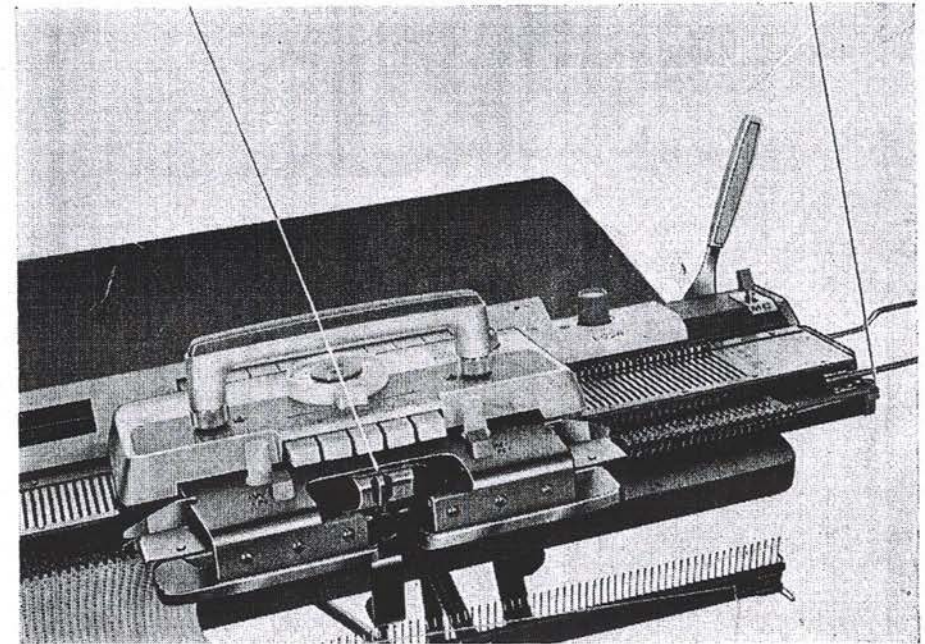

10. Zigzag pattern

14	"	"			"	"	"	"	"					"	2	"			→	
13	"	"			"	"	"	"	"					"	3	"			←	
12	"	"			"	"	"	"	"					"	4	"			→	
11	"	"			"	"	"	"	"					"	5	"			←	
10	"	"			"	"	"	"	"					"	6	"			→	
9	"	"			"	"	"	"	"					"	7	"			←	
8	"	"			"	"	"	"	"					"	8	"			→	
7	"	"			"	"	"	"	"					"	7	"			←	
6	"	"			"	"	"	"	"					"	6	"			→	
5	"	"			"	"	"	"	"					"	5	"			←	
4	"	"			"	"	"	"	"					"	4	"			→	
3	"	"			"	"	"	"	"					"	3	"			←	
2	"	"			"	"	"	"	"					"	2	"			→	
1	a	7						3	N	N	1	2		5	6			+ 1	△	←
Steps	Color of Yarn	Tension Dial	TUCK PLAIN PART			Holding Cam Lever	Change Knob	Button For Laying-in Pattern Brush	1 2 3 4 5 6 7 8 Needle Selector Buttons Reverse Lever Slide Dial Change Lever								Laying-in Thread	Direction of L Carriage	Direction of K Carriage	
	Carriage							Pattern Center												



Laying-in patterns

Laying-in pattern apparatus is one of the wonderful features making the knitter a versatile instrument for various types of knit wear.

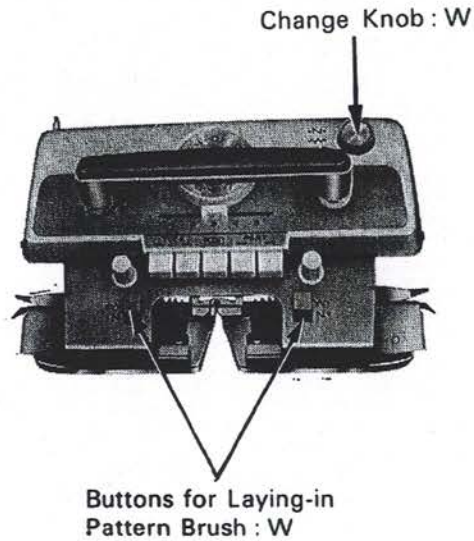

1. Press down Laying-in Knobs to W.
2. Set Change Knob on carriage to W.

11. Laying in pattern (1)

The following is the basic laying-in pattern.

2	"	"		"		"	"	"	■	■	■	■	■	■	-	"	"	"	→		
1	a	6		■		3	W	W	1	3	5	7		+	1	△	b	←			
Steps	Color of Yarn	Tension Dial	TUCK PLAIN PART			Holding Cam Lever	Change Knob	Button For Laying-in Pattern Brush	1 2 3 4 5 6 7 8								Laying-in Thread	Direction of L Carriage	Direction of K Carriage		
			Pattern Selector Buttons						Needle Selector Buttons Reverse Lever Slide Dial Change Lever												
Carriage									Pattern Center												

{ Main Yarn a 4 ply yarn
 { Laying-in Yarn b 4 "

In case of laying-in pattern knitting, always set the change lever at the marking of "△".

Thread the yarn for yarn feeder and the laying-in thread through the automatic yarn tension unit, then press down the buttons of 1, 3, 5, and 7, and then set the change lever at the mark of "△".

Step 1)

- (1) Set the reverse lever at + and select the needles.
- (2) Insert the laying-in thread from the automatic yarn tension unit into the laying-in thread feeder opening provided on the left side of the carriage.
- (3) Slide the carriage to the left.

Step 2)

- (1) Shift the reverse lever to - and select the needles.
 - (2) Take the laying-in thread from the laying-in thread feeder opening and put it in the opposite side thread feeder of the carriage.
 - (3) Slide the carriage to the right.
- (The laying-in thread will be guided to the laying-in thread feeder opening automatically. Make sure of this state before sliding the carriage.)

* After this, repeat the above steps 1) and 2).

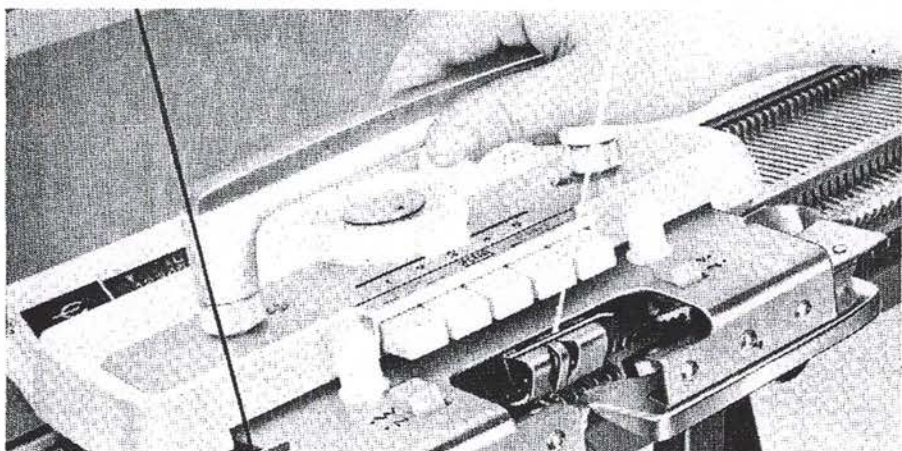

12. Laying-in pattern (2)

16	"	"		"	"	"								"	"	"				→
15	"	"		"	"	"								"	"	"				←
14	"	"		"	"	"								"	"	"				→
13	"	"		"	"	"								"	"	"				←
12	"	"		"	"	"		■	■		■	■		"	"	"	"			→
11	"	"		"	"	"		■	■		■	■		+	"	"	"			←
10	"	"		"	"	"		■	■		■	■		"	"	"	"			→
9	"	"		"	"	"		■	■		■	■		"	"	"	"	b		←
8	"	"		"	"	"								"	"	"				→
7	"	"		"	"	"								"	"	"				←
6	"	"		"	"	"								"	"	"				→
5	"	"		"	"	"								"	"	"				←
4	"	"		"	"	"		■	■		■	■		"	"	"	"			→
3	"	"		"	"	"		■	■		■	■		-	"	"	"			←
2	"	"		"	"	"		■	■		■	■		"	"	"	"			→
1	a	6		■			3	W	W	1	2		5	6	+	1	△	b		←
Steps	Color of Yarn	Tension Dial	TUCK PLAIN PART		Holding Cam Lever	Change Knob	Button For Laying-in Pattern Brush	1 2 3 4 5 6 7 8								Laying-in Thread	Direction of L Carriage	Direction of K Carriage		
			Pattern Selector Buttons					Needle Selector Buttons Reverse Lever Slide Dial Change Lever												
	Carriage							Pattern Center												

- { Main Yarn a 4 ply yarn
- { Laying-in Yarn b 4 "



13. Laying-in pattern (3)

For this pattern, thick wool is suitable as laying-in yarn.

12	"	"							"	"	"							"	2	"	"		→
11	"	"							"	"	"							"	3	"	"		↑
10	"	"							"	"	"							"	4	"	"		→
9	"	"							"	"	"							"	5	"	"		↑
8	"	"							"	"	"							"	6	"	"		→
7	"	"							"	"	"							"	7	"	c		↑
6	"	"							"	"	"							"	6	"	"		→
5	"	"							"	"	"							"	5	"	"		↑
4	"	"							"	"	"							"	4	"	"		→
3	"	"							"	"	"							"	3	"	"		↑
2	"	"							"	"	"							"	2	"	"		→
1	a	8							3	W	W	1						5					↑
Steps	Color of Yarn	Tension Dial	TUCK PLAIN PART			Holding Cam Lever	Change Knob	Button For Laying-in Pattern Brush	1 2 3 4 5 6 7 8								Laying-in Thread	Direction of L Carriage	Direction of K Carriage				
			Pattern Selector Buttons						Needle Selector Buttons Reverse Lever Slide Dial Change Lever														
Carriage								Pattern Center															

- { Main Yarn a 4 ply yarn
- { Laying-in Yarn b Bulky yarn
- { Laying-in Yarn c Bulky yarn



14. Laying-in pattern (4)

6	"	"			"	"	"	"	"	"	"	"	"	"	2	"	"	→	
5	"	"			"	"	"	"	"	"	"	"	"	"	3	"	"	←	
4	"	"			"	"	"	"	"	"	"	"	"	"	4	"	"	→	
3	"	"			"	"	"	"	"	"	"	"	"	"	3	"	"	←	
2	"	"			"	"	"	"	"	"	"	"	"	"	2	"	"	→	
1	a	6												+	1	△	b	↑	
Steps	Color of Yarn	Tension Dial	<div style="display: flex; justify-content: space-around; border-bottom: 1px solid black;"> TUCK PLAIN PART </div> <div style="display: flex; justify-content: space-around; height: 15px; border-bottom: 1px solid black;"> </div>			Holding Cam Lever	Change Knob	Button For Laying-in Pattern Brush	<div style="display: flex; justify-content: space-between; border-bottom: 1px solid black;"> 12345678 </div> <div style="display: flex; justify-content: center; align-items: center; gap: 20px;"> ⊗ Needle Selector Buttons ◇ Reverse Lever </div> <div style="display: flex; justify-content: center; align-items: center; gap: 20px;"> Slide Dial Change Lever </div>								Laying-in Thread	Direction of L Carriage	Direction of K Carriage
	Carriage						Pattern Center												

{ Main Yarn a 4 ply yarn
 { Laying-in Yarn b 4 "



15. Cable stitch pattern

Knit several rows in plain knitting before transferring the stitch to make cables.

			-						-			
			-						-			
			-						-			
10			-						-			
9			-						-			
8			-						-			
7			-						-			
6			-						-			
5			-						-			
4			-						-			
3			-						-			
2			-						-			
1			-						-			
			-						-			
			-						-			
	1	2	3	4	5	6	7	8	9	10	11	12

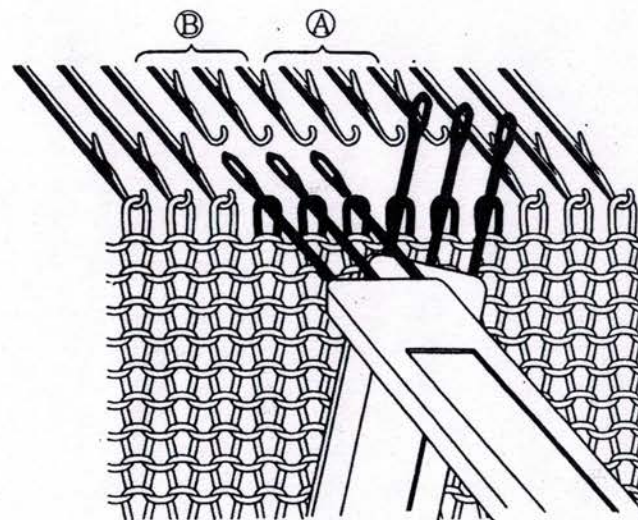

- ① Using a pair of three-eye transfer tools pick up three stitches with one transfer tool, and the adjacent three stitches with the other tool

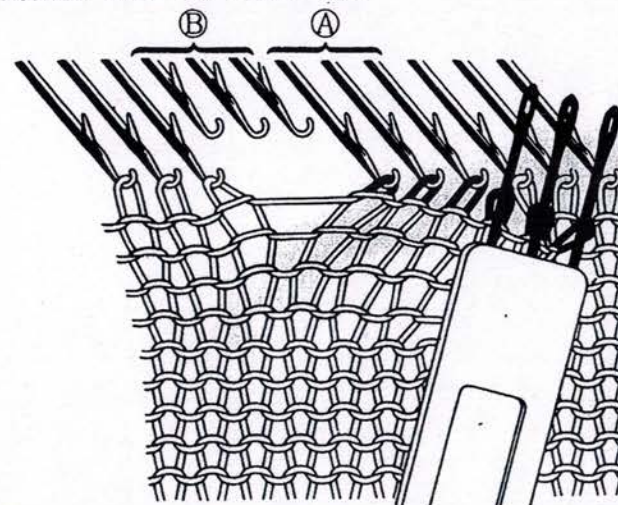

- ② Place the three stitches on the tool in your left hand onto the hooks of the machine needles on the right.

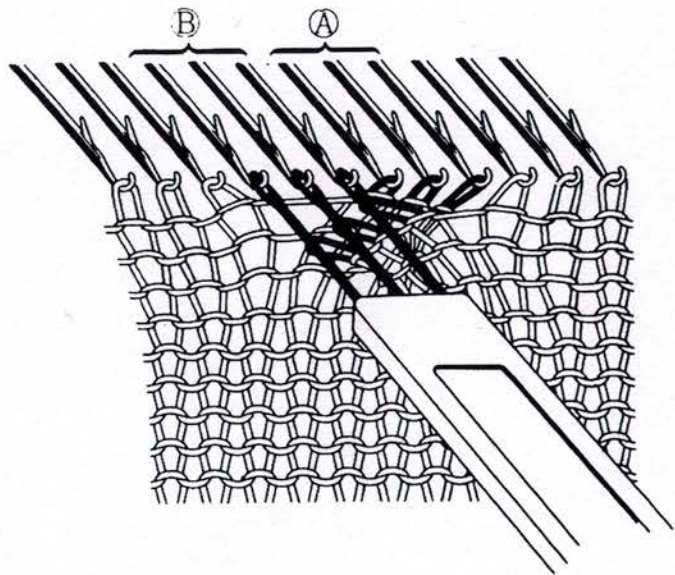

③ Place the three stitches on the other transfer tool in your right hand onto the hooks of the needles on the left.

Raise those six needles to position "E".

Knit 10 rows.

Rib two or three stitches on both sides of the pattern starting at the beginning of the knitting.



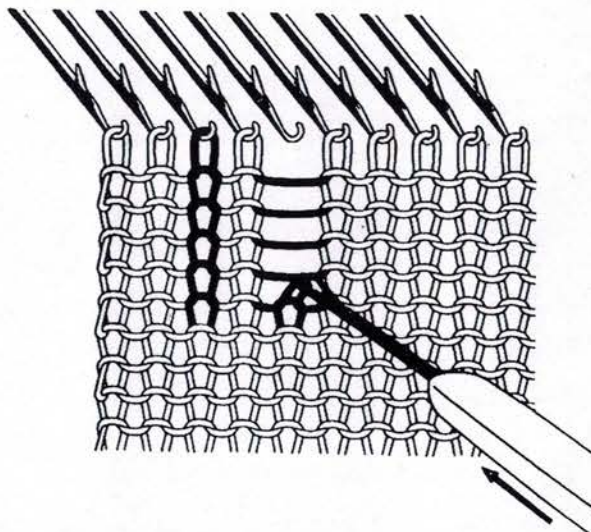

- ③ Watch the latch of tool, always pick up parallel threads one by one.
 Note that the last stitch falls behind the latch so that the next parallel thread is in front of the latch.

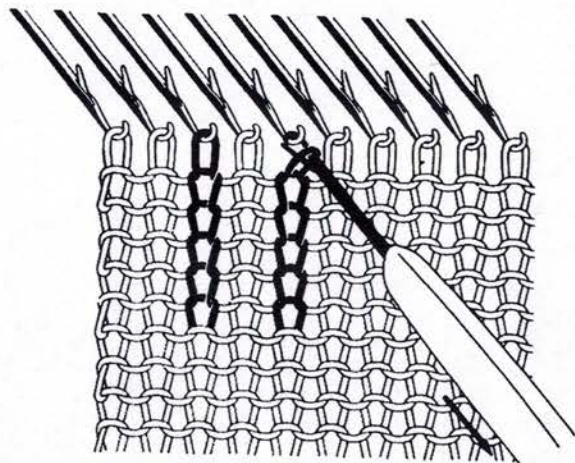

- ④ When all parallel threads are picked up, the last stitch is placed back onto the empty needle.
 Repeat steps ② and ③ for each row required to be "ribbed".



17. Garter stitch pattern

The latch tool is used.

15																							
14																							
13																							
12	-	-	-	-	-	-	-	-	-	-	-	-	-	-	-	-	-	-	-	-	-	-	-
11																							
10	-	-	-	-	-	-	-	-	-	-	-	-	-	-	-	-	-	-	-	-	-	-	-
9																							
8	-	-	-	-	-	-	-	-	-	-	-	-	-	-	-	-	-	-	-	-	-	-	-
7																							
6	-	-	-	-	-	-	-	-	-	-	-	-	-	-	-	-	-	-	-	-	-	-	-
5																							
4	-	-	-	-	-	-	-	-	-	-	-	-	-	-	-	-	-	-	-	-	-	-	-
3																							
2																							
1																							

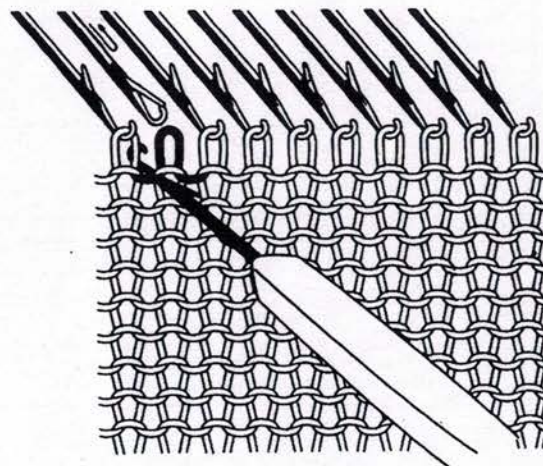

- ① Knit two rows in plain stitch.
Insert the latch tool in second underneath stitch.
Remove the stitch from the needle and shake the latch tool with the stitch on the stem of the latch tool and ladder one stitch.

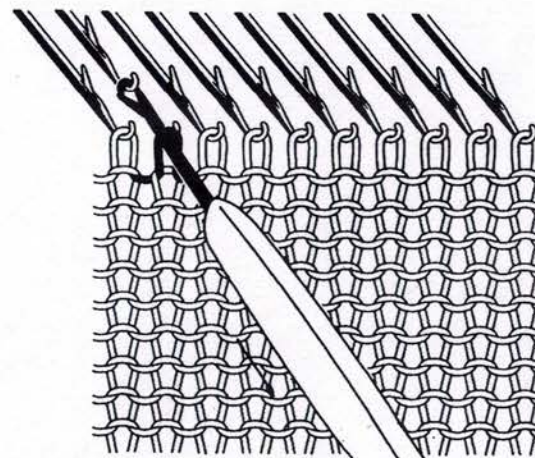

- ② Knit one ladder and make one stitch and transfer it on the empty needle.

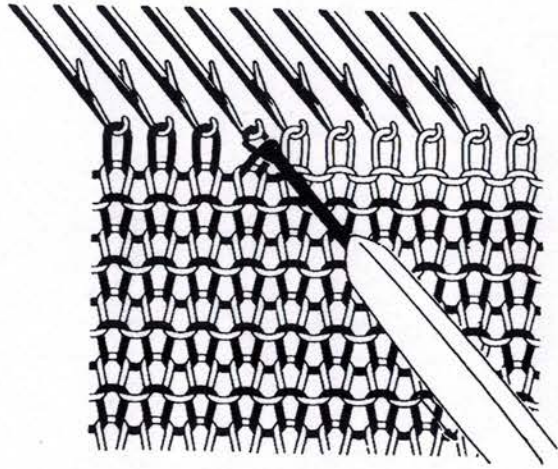

③ Repeat ① and ② operation on all stitches on one row.



18. Tube knitting

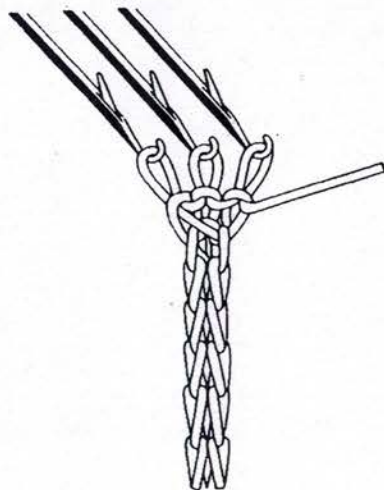

- ① Cast-on 3 or 4 needles.
- ② To get fine finish, use a slightly tight tension.
- ③ Depress right PART button.
- ④ Pull down the fabric by left hand, and move the carriage by right hand.

KNITTING LACE PATTERN USING L CARRIAGE

The L carriage is used to knit lace pattern with the pattern center.



1. Preparing to knit

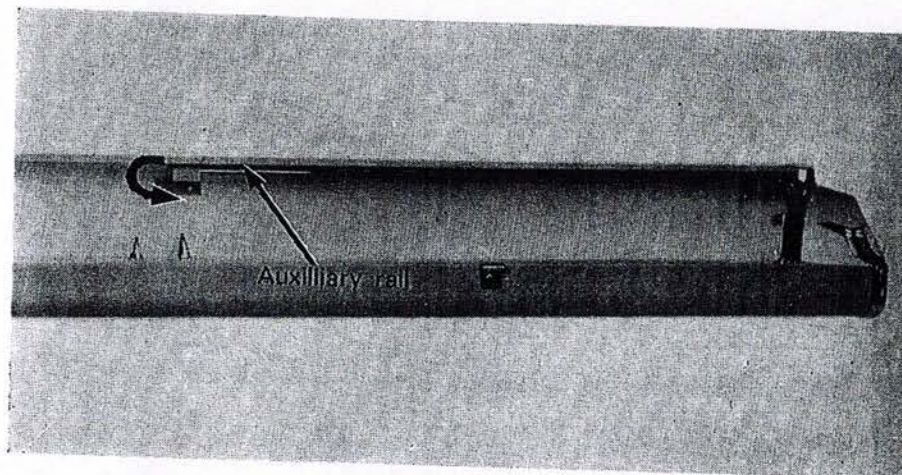

(1) Remove the auxiliary rails from the carrying case.

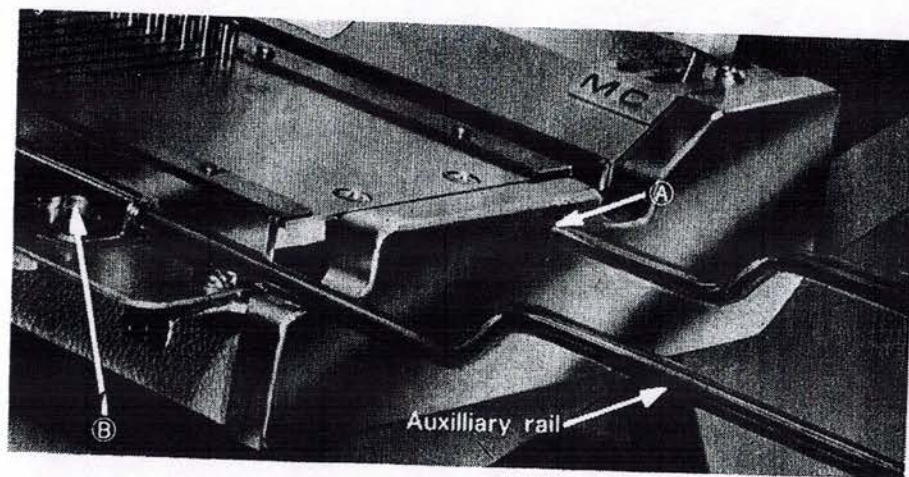

(2) Insert the auxiliary rail into the hole **A** and under the auxiliary rail fastener **B** on the end of knitting machine.

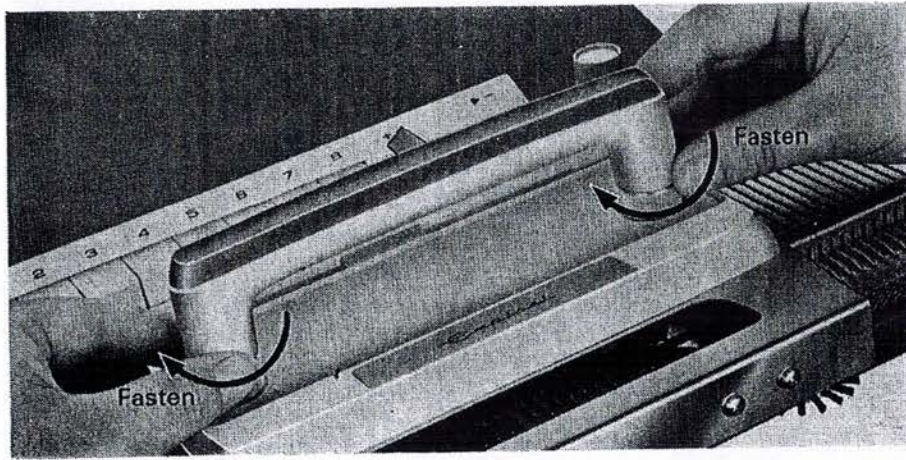

(3) Fasten the handle on the L carriage.

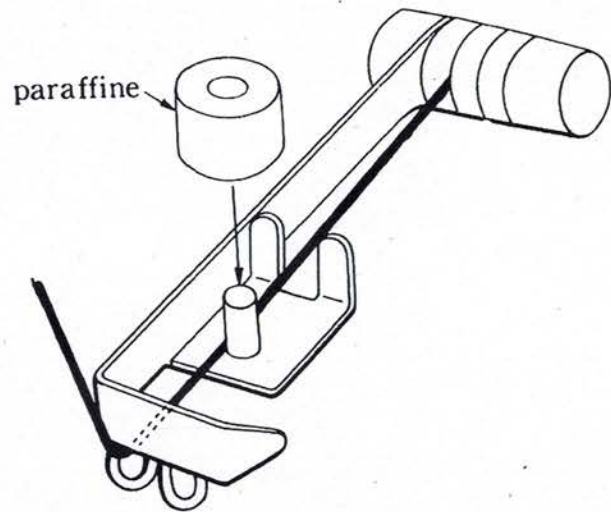

Fit paraffin to stud on front yarn guide.

2. How to use the L carriage

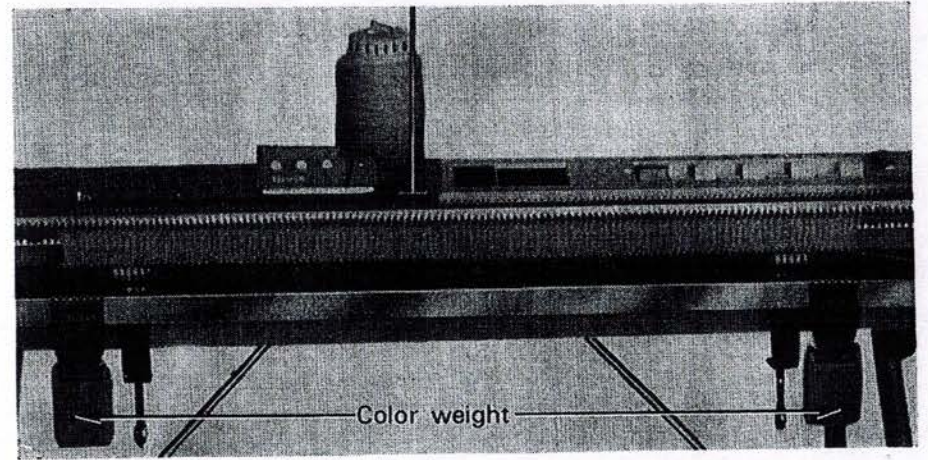

(1) Knit several rows in plain knitting, hang the color weight on the cast-on comb.

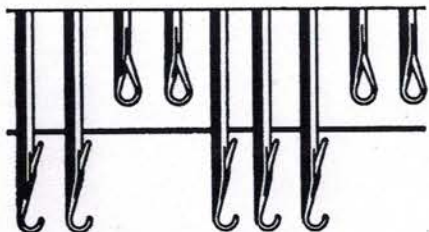

(bad)

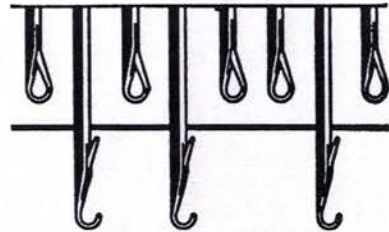

(good)

(2) Swivel the set lever and select the needles.

When the needles are selected together with the adjacent needle, you can not knit. Therefore, make sure not to move the L carriage.

In case of lace knitting, the change lever must be set at "△".

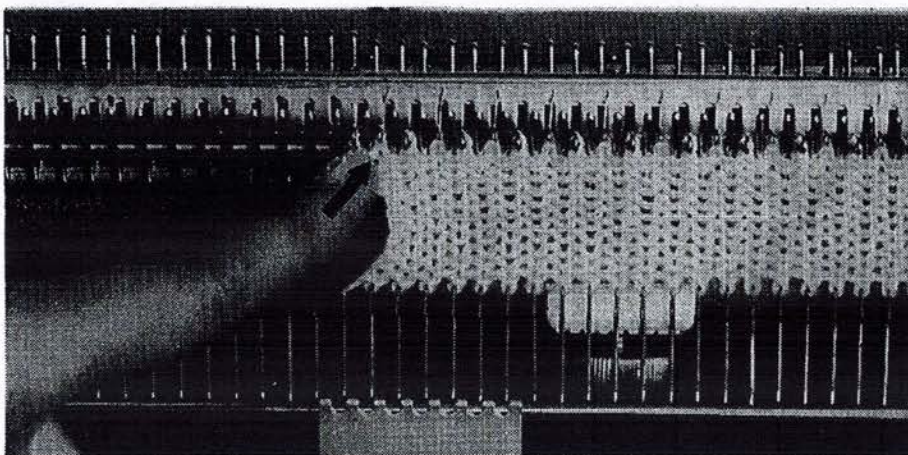

* In case the end needle is selected, push it back with your finger.

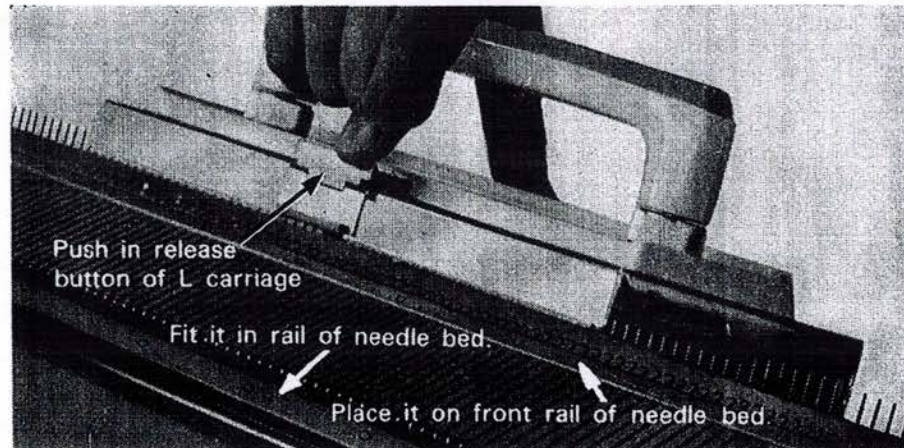

(3) Set the L carriage and make sure the rear side of L carriage fits in the back rail of needle bed.

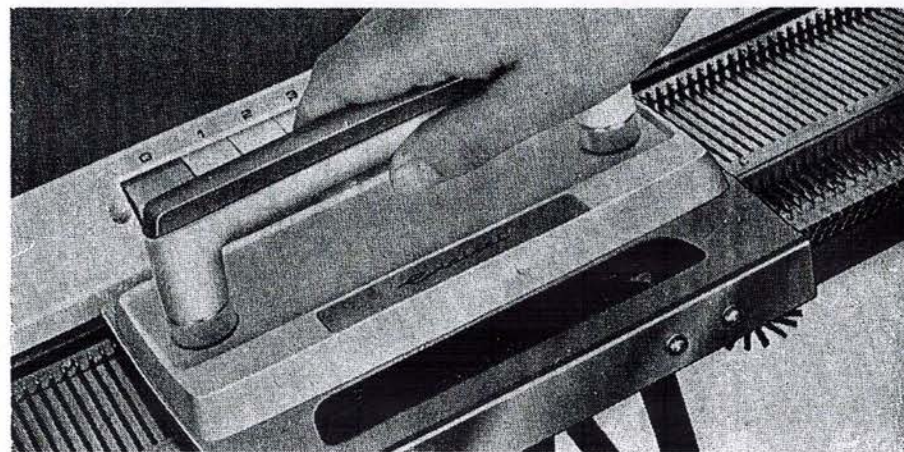

(4) Move the L carriage slowly.

If the L carriage is jammed, see page 71.

(5) Knit with the carriage.

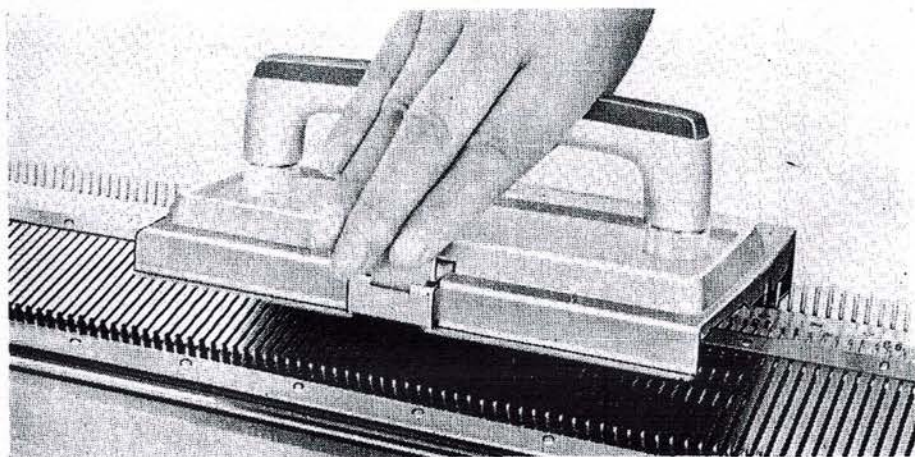

《To unlock the L carriage》

- ① Push in the release button of the L carriage.
- ② Lift the rear of it and pull it toward you.

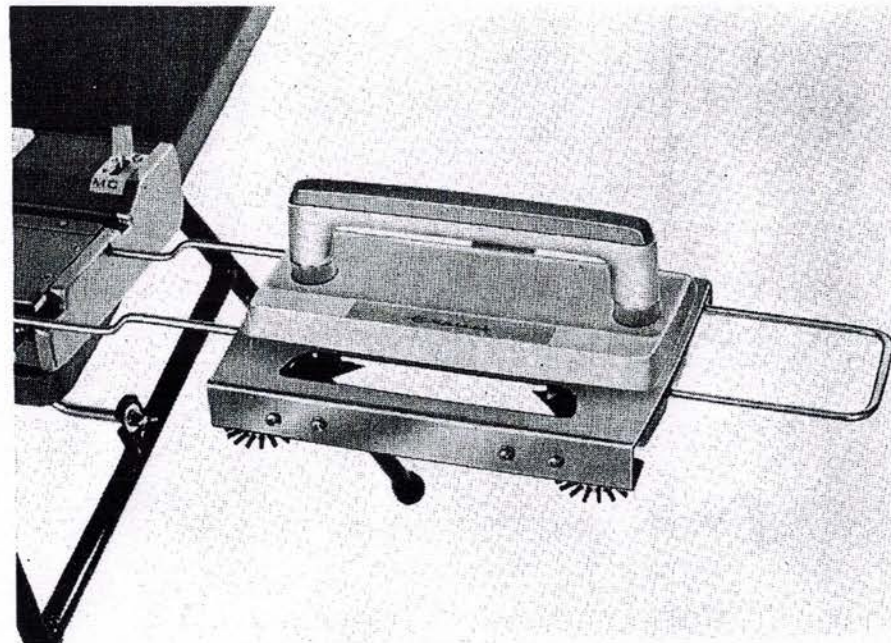

《To reset the released L carriage on the auxilliary rail》

When you reset the released L carriage on the auxilliary rail, place it right on the rail, as shown in figure.

3. How to knit Lace Pattern

How to read the pattern knitting table

<Example>

4	//	//			//			//	//	//	1						//	//	//		←	↺		
3	//	//			//			//	//	//							//	2	//		→	↻		
2	//	//			//			//	//	//							//	//	//		←	↻		
1	a	5						3	N	N	1						+	1	△		→	↻		
Steps	Color of Yarn	Tension Dial																	Laying-in Thread	Direction of L Carriage	Direction of K Carriage			
			Pattern Selector Buttons																					
Carriage										Pattern Center														

Steps :

Operate the knitter in numerical order.

The required operation is shown in the lateral row of each step.

Needle Selector Buttons :

- means pushing down button "1" and operation of the set lever.
- means operation of the set lever without pushing down button.

Slide dial :

Turn the slide dial before operating the lever and set the slide indicator.

Direction of the L carriage :

Move the L carriage according to the direction of arrow.

Direction of the K carriage :

Move the K carriage according to the direction of arrow.

→ one row

↻ two rows

- * Always operate the L carriage before operating the K carriage.
- * Place the K carriage at first on the right side of the needle bed.
- * Set the reverse lever to position "+".

《Lace pattern (2)》

12	"	"		"		"	"	"							5			"	"	"	←	↻
11	"	"		"		"	"	"			3							"	"	"	→	↻
10	"	"		"		"	"	"							6			"	"	"	←	↻
9	"	"		"		"	"	"			2							"	"	"	→	↻
8	"	"		"		"	"	"								7		"	"	"	←	↻
7	"	"		"		"	"	"										"	"	"	→	↻
6	"	"		"		"	"	"			1							"	"	"	←	↻
5	"	"		"		"	"	"								7		"	"	"	→	↻
4	"	"		"		"	"	"			2							"	"	"	←	↻
3	"	"		"		"	"	"								6		"	"	"	→	↻
2	"	"		"		"	"	"				3						"	"	"	←	↻
1	a	5						3	N	N					5			+	1	△	→	↻
Steps	Color of Yarn	Tension Dial	TUCK PLAIN PART			Holding Cam Lever	Change Knob	Button For Laying-in Pattern Brush	1 2 3 4 5 6 7 8								Laying-in Thread	Direction of L Carriage	Direction of K Carriage			
			Pattern Selector Buttons						Needle Selector Buttons Reverse Lever Slide Dial Change Lever													
Carriage							Pattern Center															



27

《Lace pattern (3)》

12	"	"		"		"	"	"							5			"	"	"	←	↺
11	"	"		"		"	"	"	1									"	"	"	→	↻
10	"	"		"		"	"	"							5			"	"	"	←	↺
9	"	"		"		"	"	"	1									"	"	"	→	↻
8	"	"		"		"	"	"							5			"	"	"	←	↺
7	"	"		"		"	"	"	1									"	"	"	→	↻
6	"	"		"		"	"	"		2								"	"	"	←	↺
5	"	"		"		"	"	"					4					"	"	"	→	↻
4	"	"		"		"	"	"		2								"	"	"	←	↺
3	"	"		"		"	"	"						4				"	"	"	→	↻
2	"	"		"		"	"	"		2								"	"	"	←	↺
1	a	5		■					3	N	N			4				+	1	△	→	

Steps	Color of Yarn	Tension Dial	TUCK PLAIN PART	Holding Cam Lever	Change Knob	Button For Laying-in Pattern Brush	1 2 3 4 5 6 7 8	Laying-in Thread	Direction of L Carriage	Direction of K Carriage
	Color of Yarn	Tension Dial	Pattern Selector Buttons	Holding Cam Lever	Change Knob	Button For Laying-in Pattern Brush	Needle Selector Buttons			
Carriage						Pattern Center				



HOW TO KNIT GARMENTS

SPECIAL ADDITIONS TO SIMPLIFY STILL FURTHER THE KNITTING AND FINISH OF A GARMENT.

HEMS:

1. To the main yarn add enough contrast yarn to knit 4 rows.
2. Bring forward the required number of needles, line up with carriage (Move carriage from left to right and back again to bring working needles into B position).
3. Hold cast-on comb centred to the edge of the needle bed, with the hooks of the comb facing you. Secure the comb between pegs of the needle bed, using the securing pins at the end of the comb.
4. On a tension 6 points looser than required tension, knit 1 row of contrast yarn.
5. Lower comb and fasten beginning of yarn on left side of cast-on spring.
6. Knit 3 more rows of contrast and 1 row of main yarn.
7. Set tension for ply used and knit required number of rows for depth of hem.
8. Knit turning row of hem on a looser tension. Then turn back to previous tension.
9. Knit the same number of rows as in Step 7 plus 1 row.
10. Remove cast-on comb and break contrast yarn from main yarn, leaving knot on main yarn.
11. Using transfer tool pick up 1st row of main yarn loops

and place them on corresponding needles.

12. Pull out contrast yarn. Loosen tension 6 points and knit 1 row. This will close hem. Reset tension and knit.

PICOT HEM :

1. Proceed as for HEM to Step 8, then instead of doing turning row, use the single transfer tool and starting at the 2nd stitch from the edge, transfer every alternate stitch to the adjacent needle. When row is complete, every 2nd needle is empty, the others hold 2 stitches. Bring empty needles back into B position and knit 1 row.
2. ANOTHER METHOD is to press buttons 1. 3. 5. 7. set the lever, pass lacemaker across and knit 1 row.

Now proceed from Step 9 of Hem instructions.

CONTINENTAL RIB :

These are your basic instructions for knitting ribs for all garments without the aid of a ribbing attachment.

Yarn	Rib	Tension 1	Tension 2	Tension 3
3 ply	1 × 1	5	1	4.2
	2 × 1	5	1.1	4.2
4 ply	1 × 1	6	2	6.1
	2 × 1	6	3	6.1
5 ply	1 × 1	7	3.1	7.1
	2 × 1	7	4.2	7.1
8 ply	1 × 1	9	6	10
	2 × 1	10	8	10
12 ply (every 4th needle).	1 × 1	9	4 or 5	9

1. Bring up the required number of needles using the even edge of a 1 × 1 needle pusher, to position B, the needles distributed evenly on each side of "O".
2. Using the needle pusher, push back alternate needles to A position. This sets the needles for K1 P1 border.
3. Attach cast-on comb as in Step 3 of Hem.
4. On 1st tension knit 1 row of contrast yarn from left to right, pushing carriage gently across past the cast-on comb.
5. Release comb by turning pins at the ends of the comb and pull down carefully. Fasten beginning of yarn on the left side of cast-on spring.
6. Knit 3 more rows of contrast yarn and 1 row of main yarn.
7. Set tension dial on 2nd tension and knit required number of rows for rib.
8. Remove cast-on comb and fold fabric double.
9. Using transfer tool, pick up 1st row of main yarn loops and place on empty needles. Pull out contrast yarn.
10. Reset tension to 3rd tension and knit.

CONTINENTAL RIB 2 × 1 :

Bring up to B position the required number of needles, push back every 3rd needle into A position. Continue as for rib 1 × 1 until hem is required length. Take off cast-on comb, and pick up both large and small loops of main yarn and place on empty needles.

BUTTONHOLES:

- No. 1 Transfer 1 stitch to its adjacent needle, bring empty needle back into B position and knit 2 rows.
- No. 2 Transfer 1 stitch to the left and 1 stitch to the right. Bring back ONLY 1 needle into B position and knit 2 rows. Twist bottom loop of yarn over top loop and place stitch thus made onto empty needle.
- No. 3 Determine position of Buttonholes. Place a length of contrast thread over the required number of needles for the width of buttonhole. Over the same needles take the loops behind the latches and allow the latches to close over the contrast thread. Draw the loops off the latchet hooks thus forming stitches on the contrast thread. Continue knitting. After the fabric is removed from the knitter, press buttonholes lightly, draw out contrast thread and finish off open loops with needle and thread.

V-NECK:

NOTE: It is important, particularly in doing V-Necks, to only knit to the click.

Carriage on the right. Bring half the needles furthest from carriage to E position. Holding Cam on 2, then knit according to your pattern, shaping where instructed to do so. After the 4th row it is advisable to insert a claw weight into the V to prevent dropped stitches (this weight must be moved up as the knitting progresses). When one side is completed, knit other side to correspond reversing all

shapings.

SHOULDER SHAPING FOR SET-IN SLEEVE:

Holding Cam on 2. From centre knit to the last number of stitches which have been brought into E position (if pattern says cast off a certain number of stitches at armhole edge for Shoulder Shaping, these are the stitches brought into E position), bring yarn under 1st inner needle in E position and knit back to centre (this prevents a hole forming between the knitted and unknitted stitches). Proceed in this way until shoulder shaping is completed.

TO KNIT THE LAST ROW ACROSS THE HELD STITCHES- working from the centre, Holding Cam on 3, knit across. Put Holding Cam back to 2 and cast off or loosen tension 6 points, knit 1 row and do a latchet cast off.

NOTE: When knitting in pattern, the above method of Shoulder Shaping is not used, but the stitches for Shoulder Shaping are cast off each time as required for pattern.

V-NECK: BAND

Sew up one shoulder. With wrong side facing you, pick up stitches from open shoulder down to V. Knit on a tension tighter than used for garment. Decrease 1 stitch at V end every 2nd row (moving 2 stitches in 1 stitch) for depth of hem, then increase 1 stitch every 2nd row for the same number of rows. Pass threaded needle through stitches on machine, then take work off machine. Pick up stitches from back of neck down to V on other side and proceed

as before. Join V and sew up shoulder, fold band and catch down on inside through open stitches.

ROUND NECK : BAND

With wrong side facing you, pick up stitches around neck from opening. Knit 1 row on normal tension, then tighten tension 1 or 2 points every 2nd row for depth of band. Turning row is knitted on normal tension. Then set the tension to the one before turning row and increase tension 1 or 2 points every 2nd row for the same number of rows, finishing at normal tension. Pass threaded needle through stitches on machine, take work off machine. Fold band and catch down inside through open stitches.

BAND FOR CARDIGAN :

With wrong side facing you, pick up stitches from centre back down to the front, or just from neck opening down to front, depending on type of cardigan, and knit on a tension at least 3 points tighter than that used for cardigan. Knit required number of rows for band. Turning row is knitted on garment tension, and other side of band 3 points tighter again. Pass threaded needle through stitches on machine, then take work off machine. Knit other side the same putting buttonholes where required. Fold and catch down stitches with threaded needle. Finish off buttonholes.

SEWING UP :

SPECIAL NOTE: All work must be sewn up on the right

side. In order to obtain a professional finish to a knitted garment, it is important that it is correctly sewn up, stitch meeting stitch, etc.

TO SEW UP RIBBING :

With tapestry needle and thread, pick up 2 loops in the middle of the edge stitch on one side of rib on garment, then repeat this on other side of garment to be joined. Then work from side to side, needle going in where it came out on the previous row.

TO SEW ON STRAPPING :

Pick up 2 loops in the middle of the edge stitch of the strapping and 2 loops in between the 1st and 2nd stitches from the edge of garment if in stocking stitch - in the middle of edge stitch if garment is ribbed.

TO SEW UP STOCKING STITCH :

Pick up 2 loops in between the 1st and 2nd stitch from edge of garment, then repeat this on other side of garment to be joined. Proceed to work from side to side, needle going in where it came out on the previous row.

TO SEW UP RAGLAN :

Proceed as for instructions for stocking stitch method.

TO SEW IN SET-IN SLEEVE :

Pin in sleeve, and work from side to side, picking up loops inside the cast off stitches. It is advisable to sew in the sleeves before sewing up the sides of garment.

1. Partial knitting in Plain stitch

Decreasing stitches

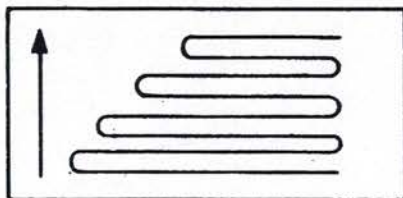

Set the holding cam lever in position 1.

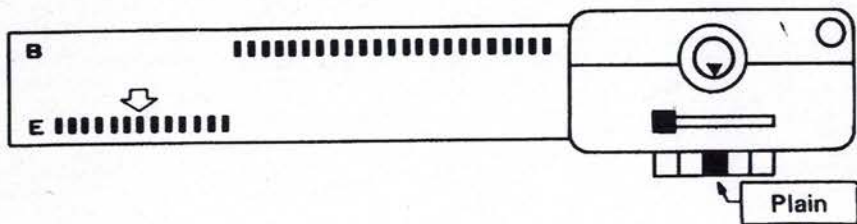

1) Bring up the needles in the opposite side of carriage, to position "E".

The number of needles to be raised to position "E", depends on the shape of the curve.

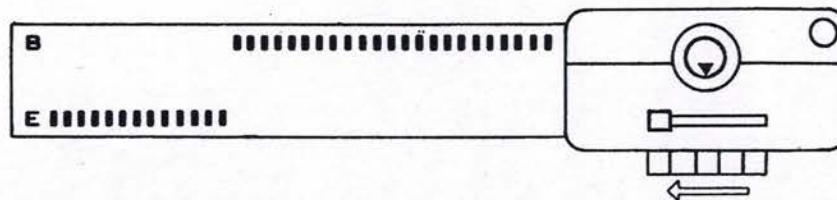

2) Knit one row.

When stitches are made with the needles in the position "B", the yarn lies across on the stems of the needles in position "E".

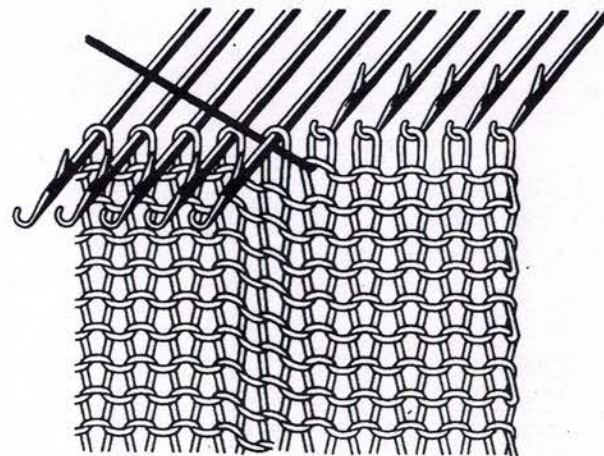

3) Pass the yarn under the stem of the first needle in position "E", this avoids making a hole.

《How to transfer the stitch》

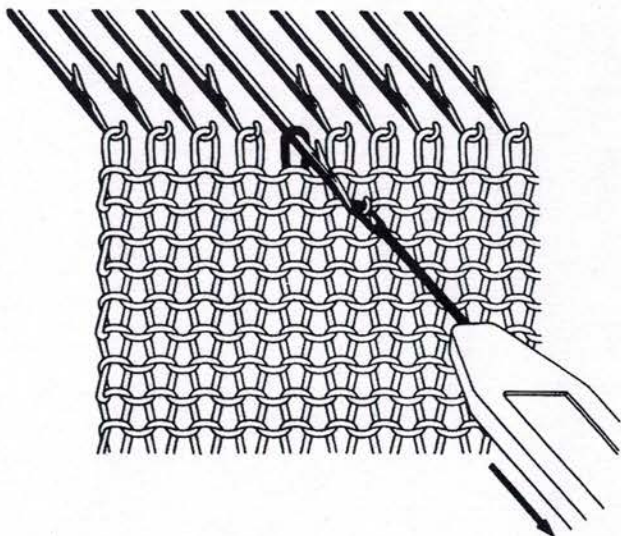

- (1) Hold the transfer tool parallel with the needle and place the eye of the transfer tool into the hook of the needle. Bring the needle forward. The stitch in the hook of the needle will slide behind the latch and onto the needle.

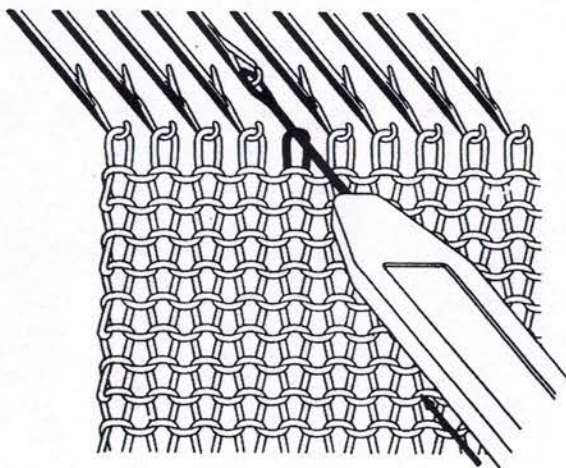

- (2) Without releasing the transfer tool from the hook of the needle, push the needle all the way back until the stitch is transferred onto the transfer tool.

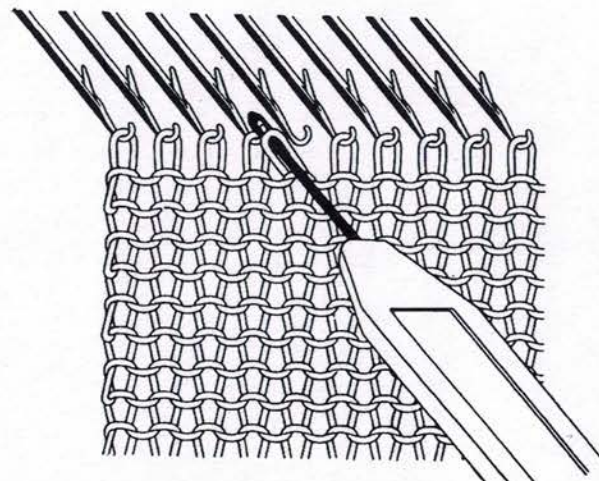

- (3) Raise the transfer tool with the stitch on it and transfer it to the adjacent needle.

2. Increasing stitch

Increasing one stitch at either edge

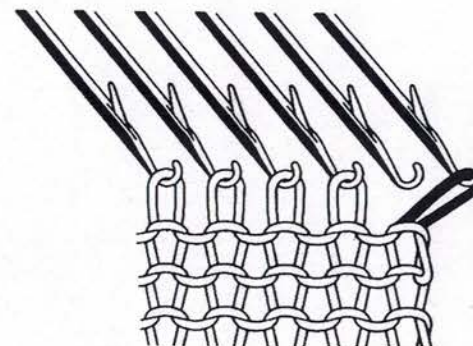

- (1) Use the transfer tool, move the stitch out to the adjacent empty needle.

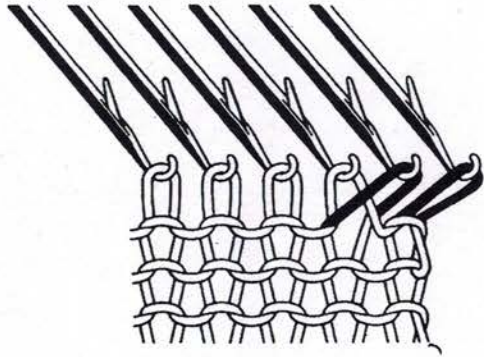

(2) To fill in empty needle pick up stitch from second needle in lower row.

· **Increasing several stitches at either edge**

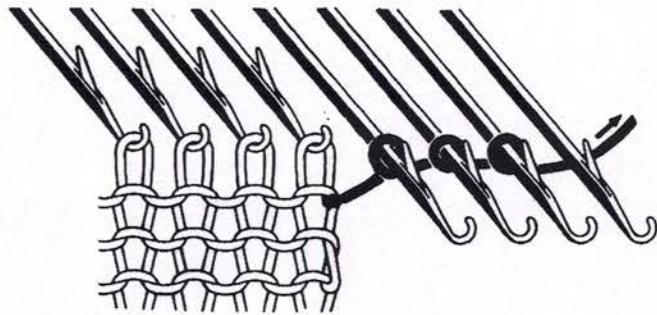

Bring into action on the same side as the carriage.
The increasing needles to position "E". Wind yarn around stem of each needle. Lower weaving knob to W.

3. Decreasing stitch

· **Decreasing one stitch at either edge**

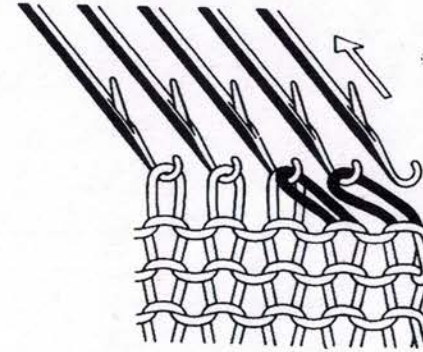

* Use the 2×1 transfer tool to transfer two stitches at the end to the inside needles, and place empty needle out of action to position "A".

· **Other method of decreasing one stitch**

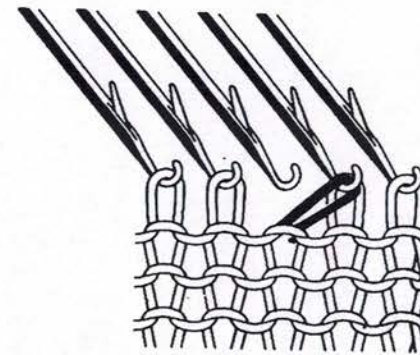

(1) Use the single transfer tool to transfer the 3rd stitch to the 2nd stitch.

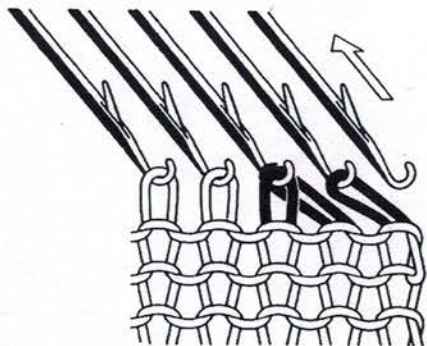

- (2) Transfer the 2nd stitch to the empty 3rd needle and the end stitch to the 2nd needle. Place empty needle out of action.

• **Decreasing several stitches**

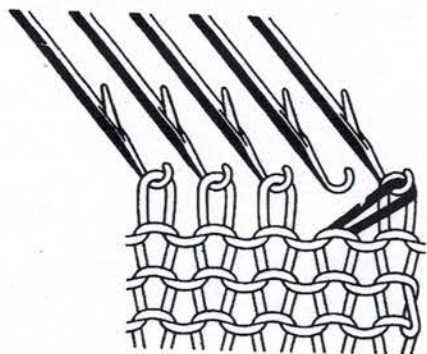

- (1) Do it from the side where the carriage is placed. Transfer the 2nd stitch to the end needle.

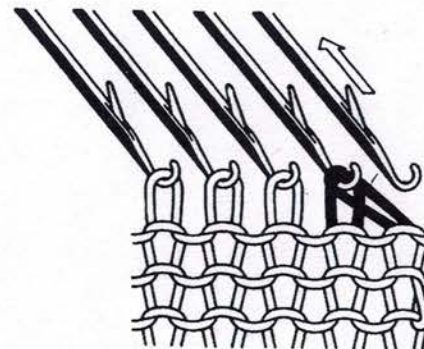

- (2) Transfer the two stitches to the 2nd needle. Place empty needle out of action.

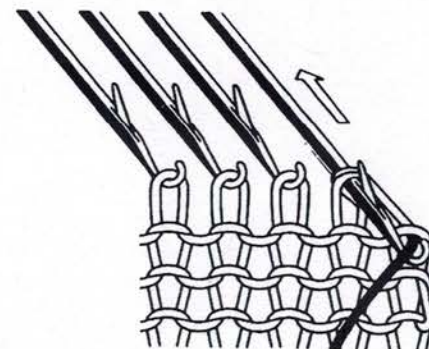
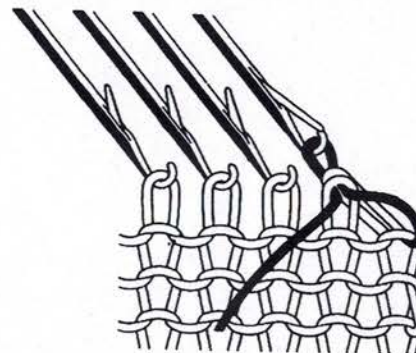

- (3) Raise the needle with the two stitches so that the stitches fall behind the latch of the needle. Lay yarn in front of latch and manually pull needle back to form a single stitch.

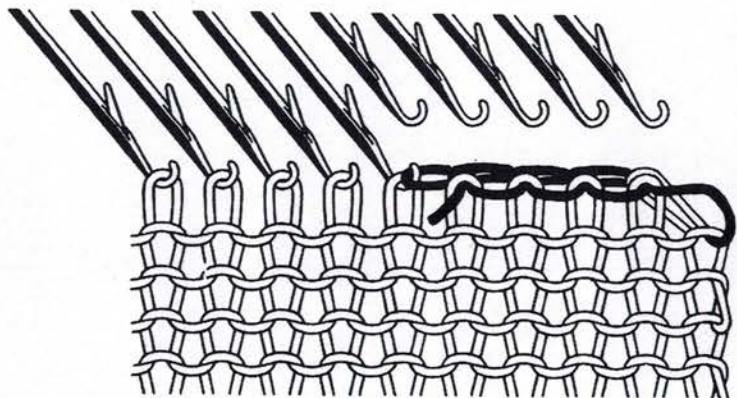

(4) Repeat this process. Transfer the last stitch to adjacent needle.

4. How to bind off

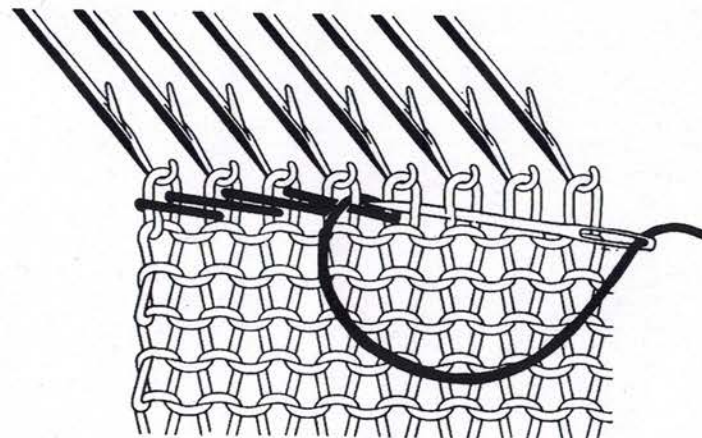
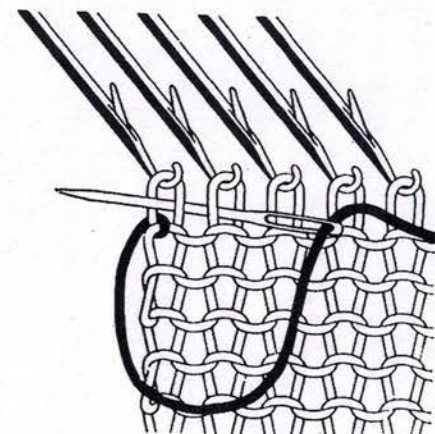
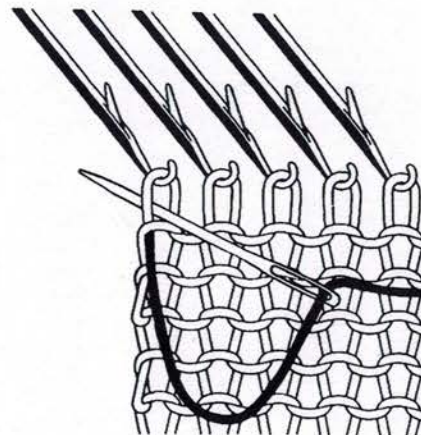

5. How to cast off

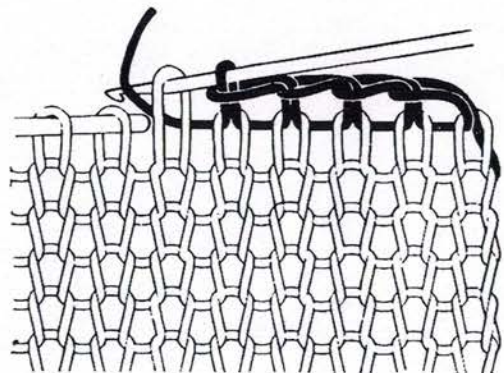

6. How to bind off one knit on purl rib

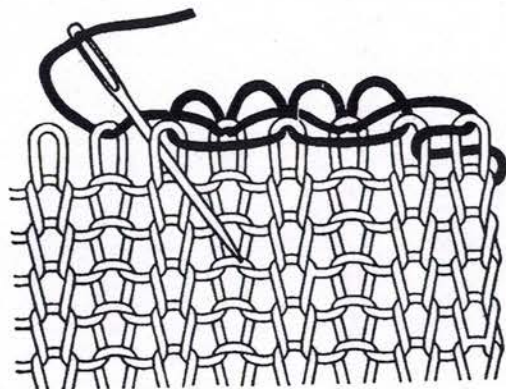

7. Waste knitting or loose course knitting

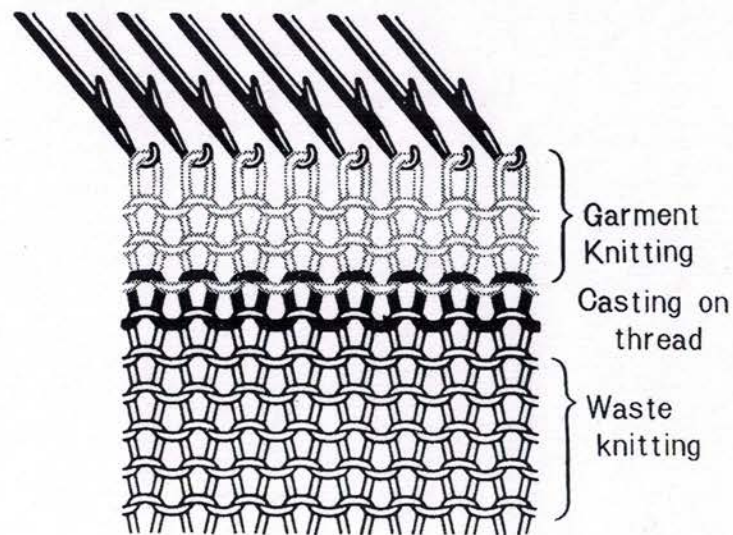

* To obtain a garment with a beautiful edge, waste knitting is used.

After waste knitting with waste yarn is finished, knit one row with the carriage with cast-on thread.

Then proceed to garment knitting.

After finishing the garment knitting, the garment and the waste knitting can be separated by pulling out the cast-on thread.

8. How to determine the gauge

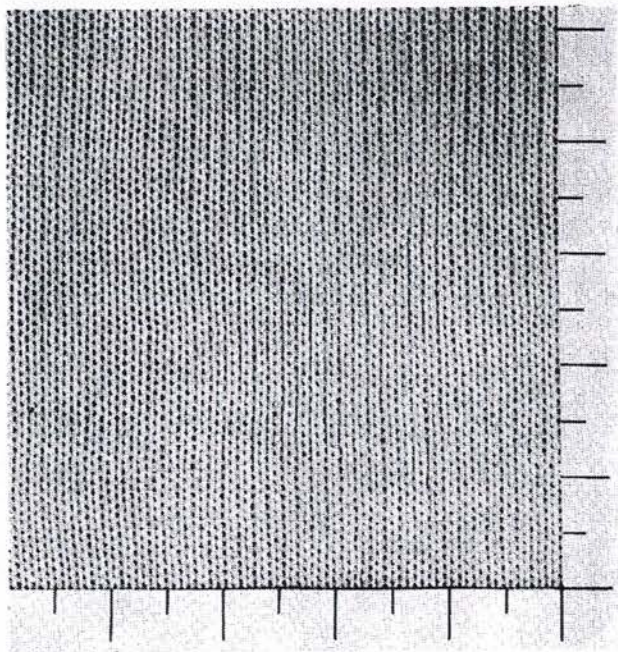

The gauge or tension determines the tightness or looseness of the stitches. Determine the proper gauge by making a swatch.

Over 60 needles knit a test piece on 60 rows on a tension suggested for that particular ply. Let swatch rest awhile. Then count the number of stitches across and rows down over 4 inches; divide by 4 and the result will be stitches and rows per inch.

Based on this mathematical approach, it soon becomes a simple matter to create your own garments on your knitter with the assurance that the size will be correct.

9. Partial knitting with the L carriage

- * Set the holding cam lever in position 3.
- * Push down both PART buttons.

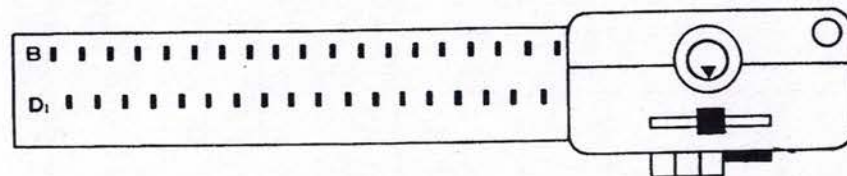

- (1) As shown in the pattern knitting table, push down needle selector buttons and swivel set lever.

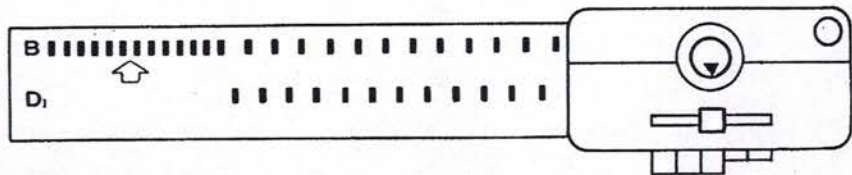

- (2) Of the selected needles, those which are not used must be pushed back to position "B".

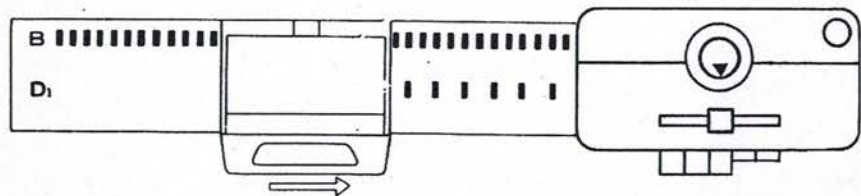

- (3) Move the L carriage in the direction shown in pattern knitting table.

* If operation of the L carriage required more than once in the pattern knitting table, repeat steps (1), (2) and (3).

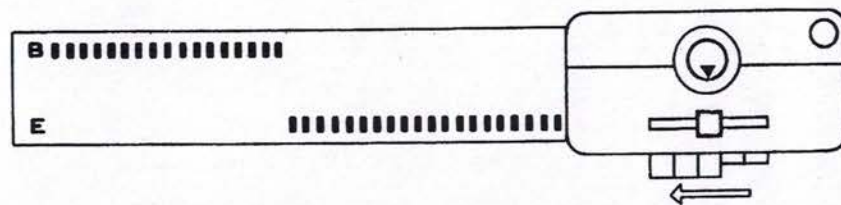

- (4) Raise the knitted needle to position "E".

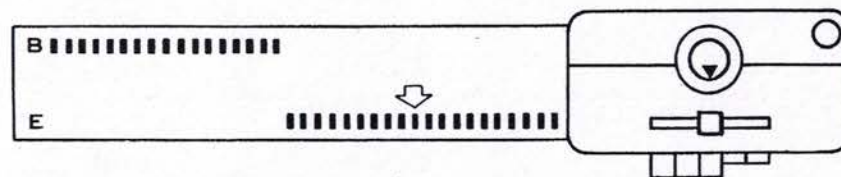

- (5) Move the L carriage in the direction shown in pattern knitting table.

* Hang the yarn in the hook of the first needle in position "B".

TROUBLES AND REMEDIES



· When the needle is bent

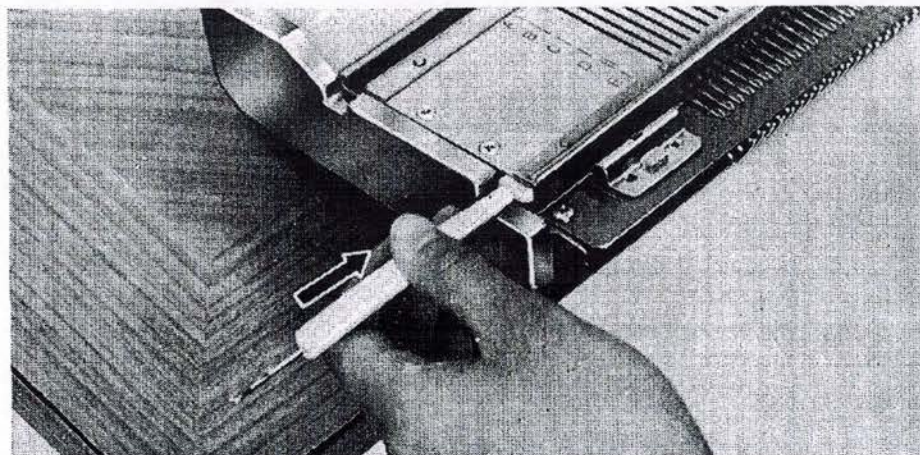

- (1) Push either side of the felt bar end piece with the end of latch tool until it comes out.

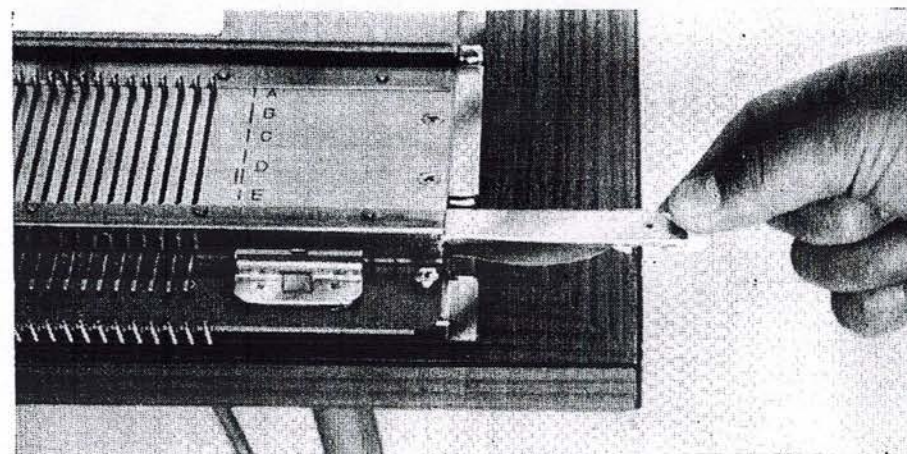

- (2) Withdraw it by hand from the knitter until the needle you wish to change is free.

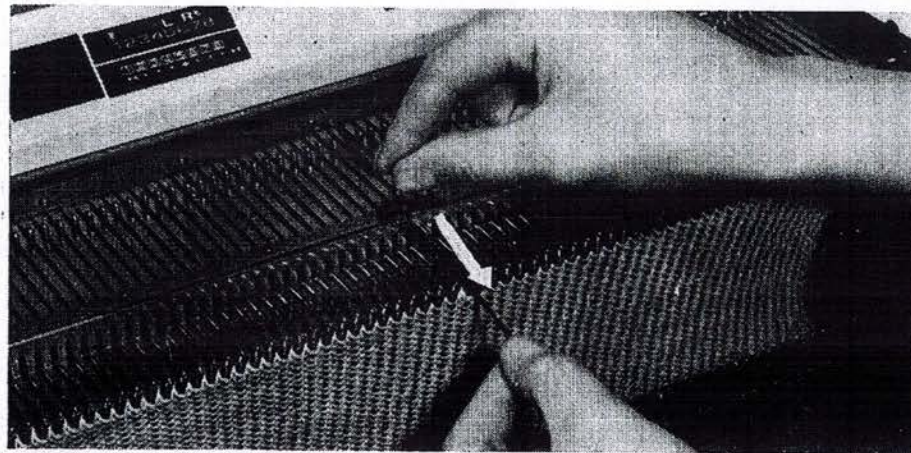

- (3) Pull the needle forward as far as it will go.
Push down the hook of the needle until shank end of the needle rises clear of the needle bed.

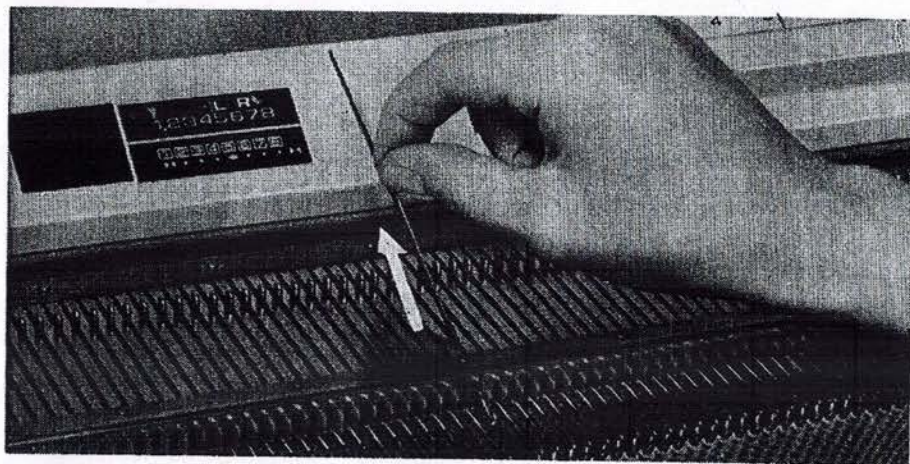

- (4) Grasp the shank end and draw it out backwards.

- (5) Replace it with a new needle by holding it with latch opened.

Push the felt bar back into place.

• When the carriage is jammed

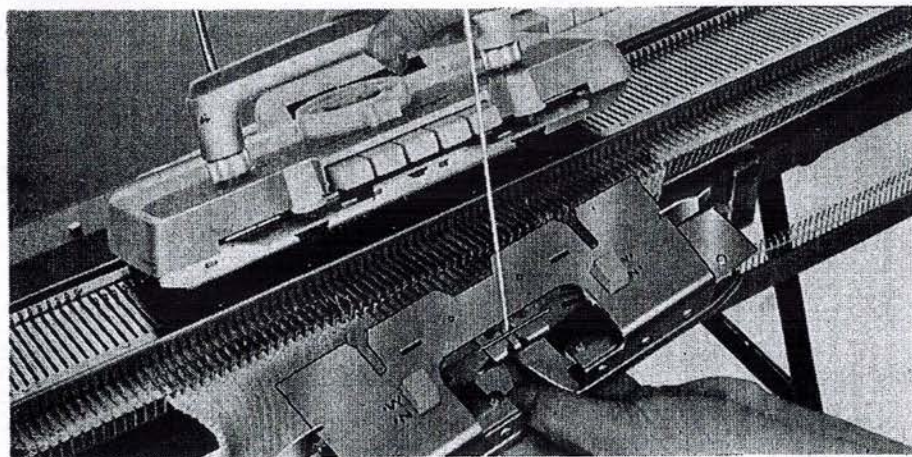

- (1) Loosen the thumb screws of the sinker plate, remove the sinker plate from the carriage.
- (2) Grip the handle of the carriage and lift the front of the carriage.
Slide the carriage to the side where the row commenced and when clear of needles lower the front onto the needle bed.
- (3) Attach the sinker plate to the carriage and fasten the thumb screws of the sinker plate securely.
- (4) Unravel last row of knitting and if necessary rethread carriage feedef.

《Undoing rows (unravelling)》

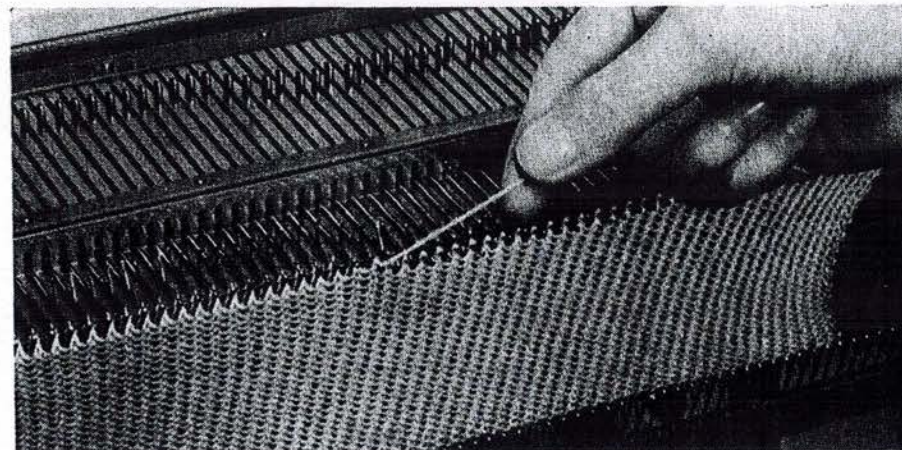

- (1) Pull yarn slightly out of stitches.
The stitches of the previous row will slip into the hooks of needles automatically as the yarn is raised towards the needle bed.
- (2) Move the carriage in either direction without knitting.
- (3) Pull the ripped yarn down through the back of the rear yarn guide until the yarn take up spring is brought back into operation.
- (4) Adjust the numbers on the row counter.

《Carriage movement without knitting》

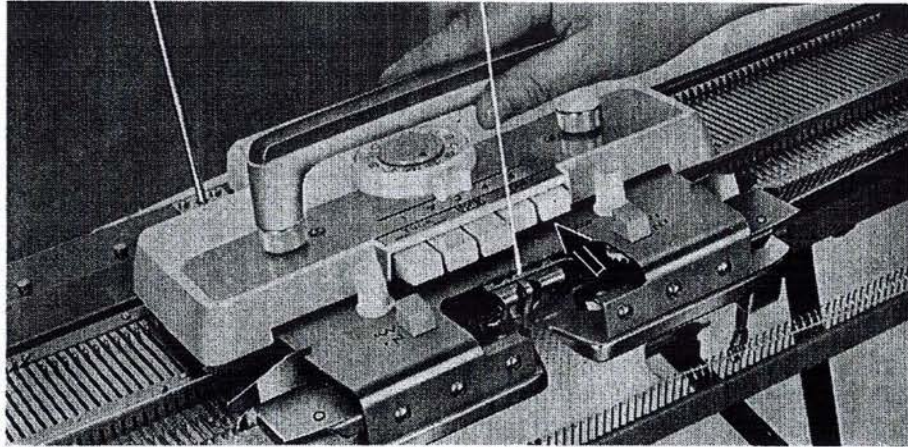

- * In case of plain knitting you can move the carriage without knitting by pushing down both PART buttons.
- * If the needles are in position DI, push back the needles in position DI to position B.
- * If the needles are in position DII or E, set the holding cam lever to 3.

《How to remove the laying-in pattern brushes》

- * Set the laying-in pattern buttons to position “N” and remove the laying-in pattern brushes from the sinker plate assembly.

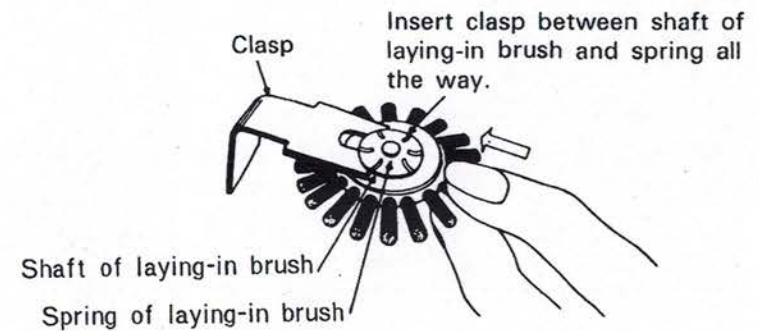
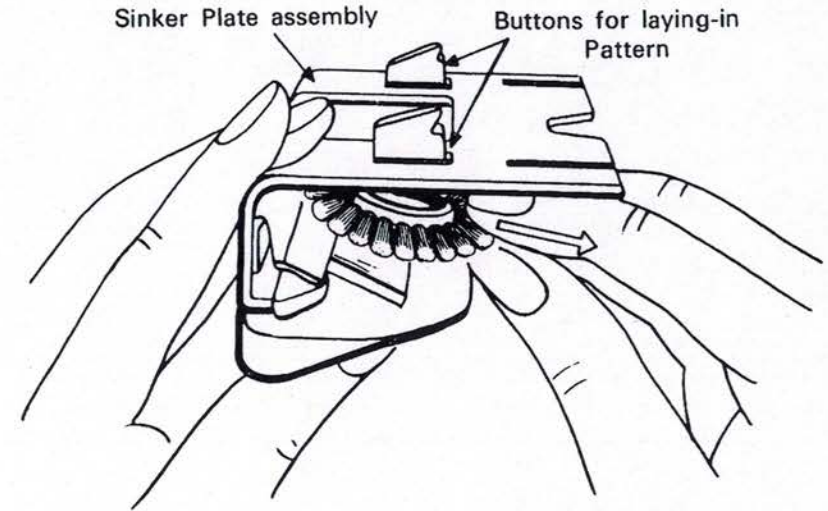

· When the L carriage is jammed

- * Remove the L carriage from its jammed position.
- * If the L carriage is caught with needles, take sufficient care in removing it.
- * After removing the L carriage, you can knit according to following steps.

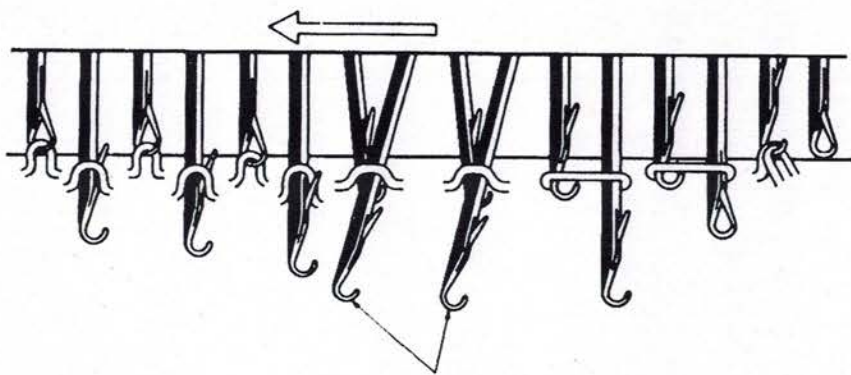

- ① If you see needles caught with each other, separate them by lifting their tips.

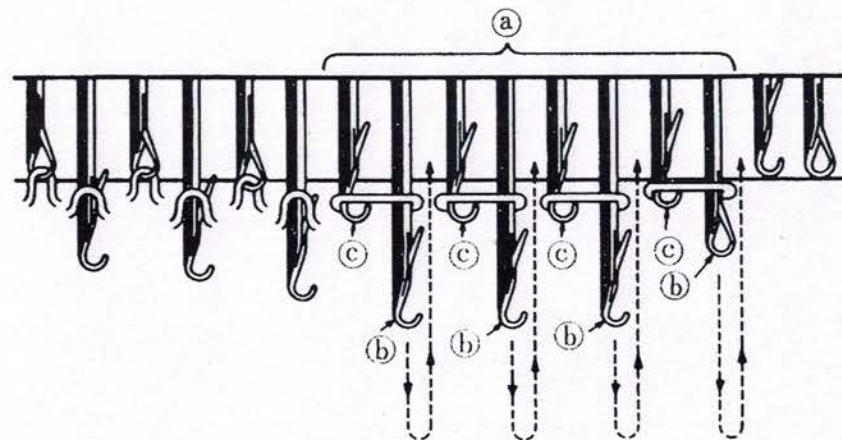

- ② If stitches are caught on two needles as shown by (a) in above figure, pull selected needles (b) toward you and push them back together with needles (c) to position "B" in order to transfer the stitches.

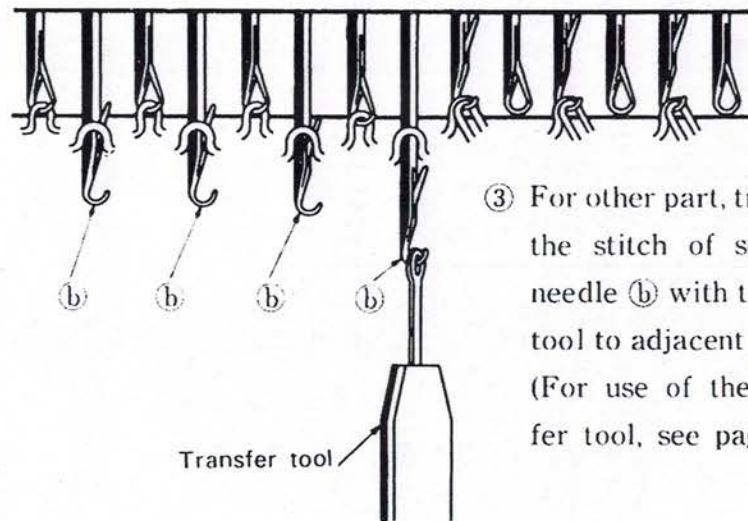

- ③ For other part, transfer the stitch of selected needle (b) with transfer tool to adjacent needle. (For use of the transfer tool, see page 60).

CARE OF YOUR KNITTING MACHINE

For best results your knitter must be kept clean and visible working parts regularly oiled.



· Oiling and cleaning

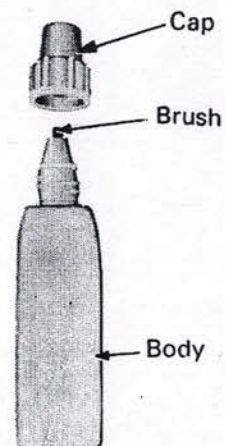

* Remove the cap and oil your machine before and after use.

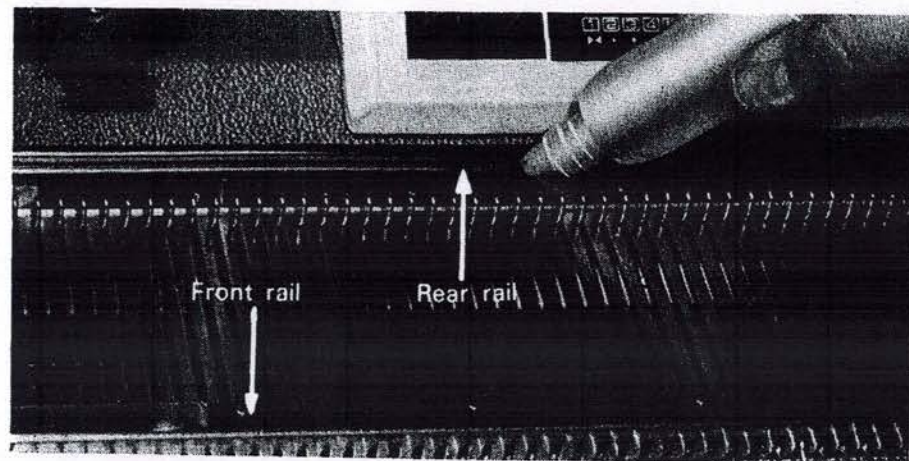

(1) The needle bed

Clean the needle bed and the carriage slide rails with clean cloth.

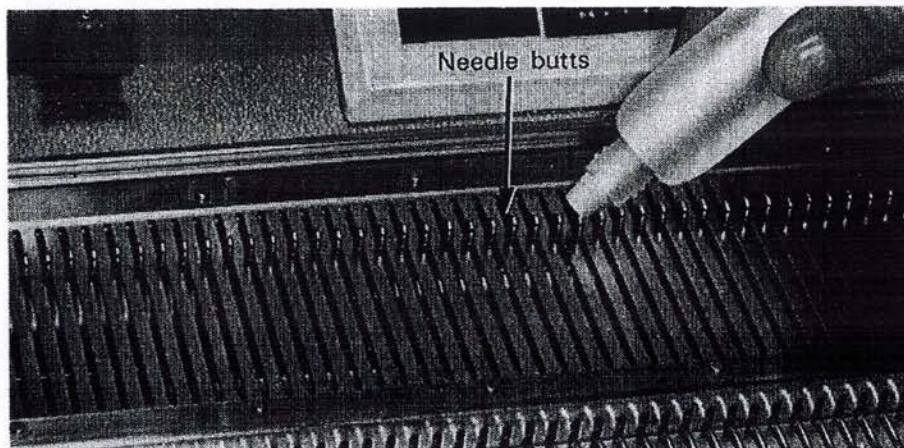

(2) The needle butts

Oil the needle butts with oiler.

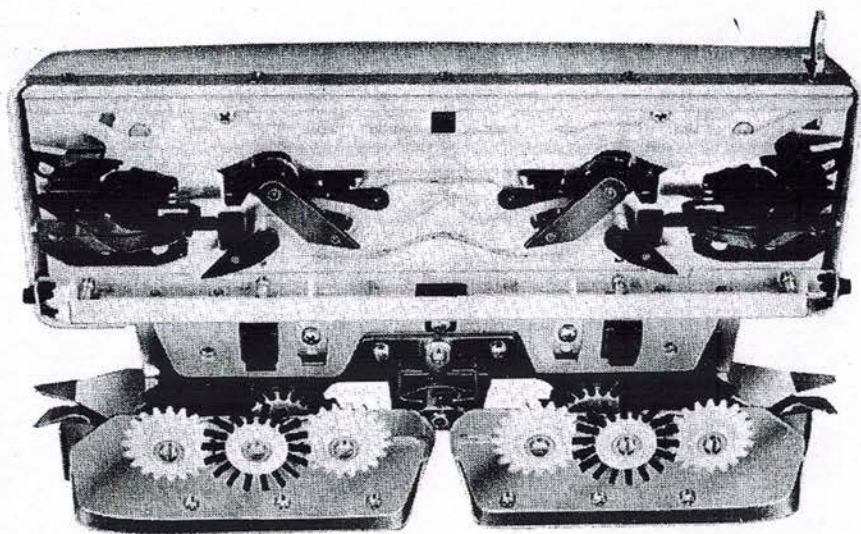

(3) The carriage

With clean cloth, wipe away all fluff.

Oil all moving parts of the carriage with oiler.

Also carriage rails.

· Note

Clean and oil your knitter each time you have finished knitting and clean off all excess oil before use, especially from parts which will come into contact with the knitting. Always leave a light film of oil on all parts between the rails under the carriage.

FOLDING UP THE KNITTER

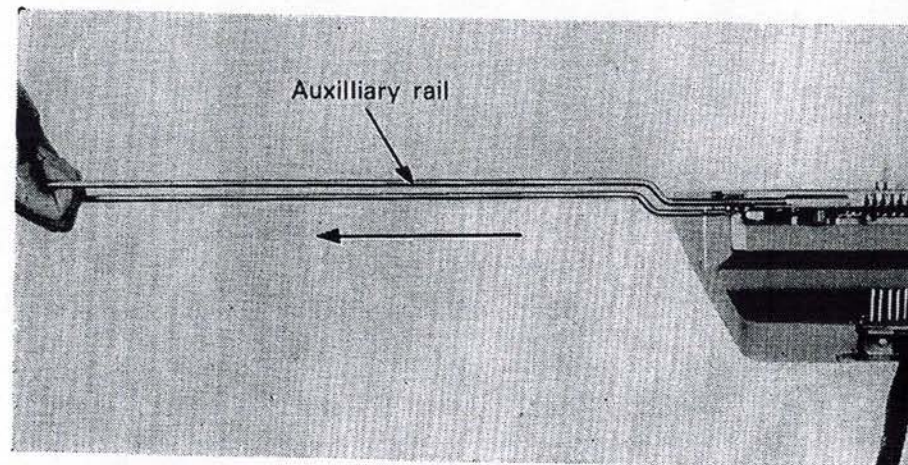

(1) Remove the auxilliary rail (lift up and pull it.)

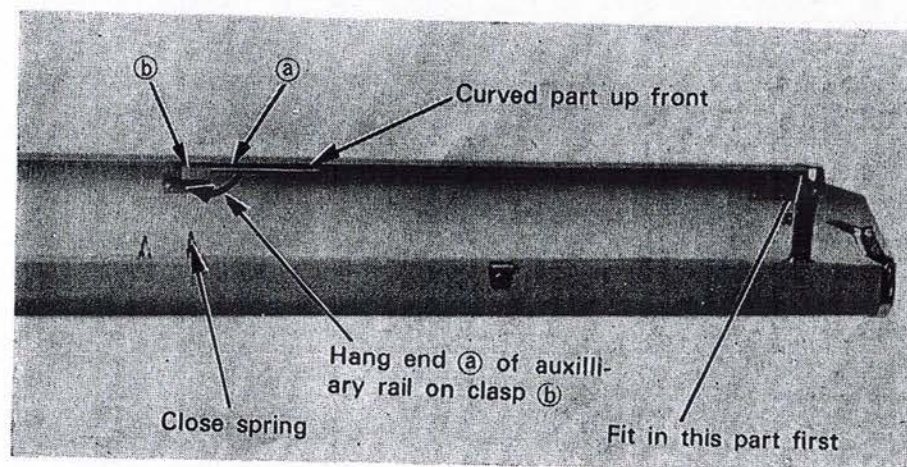

(2) Replace the auxilliary rails in the upper case as shown in figure.

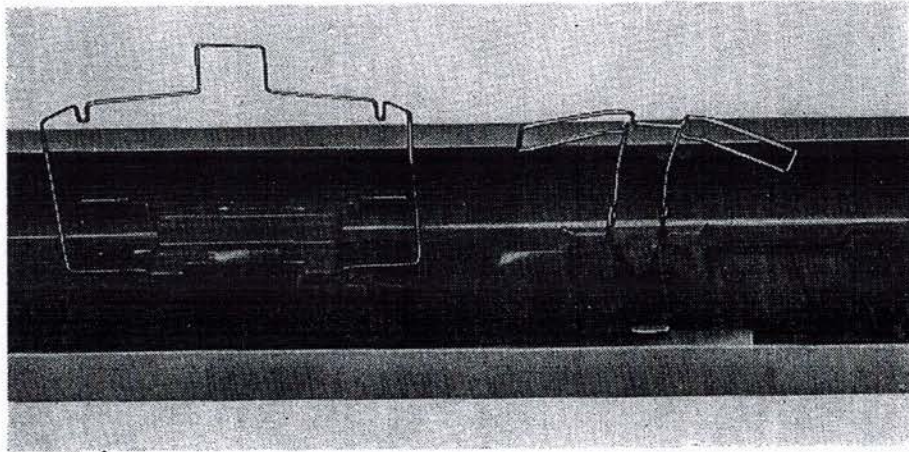

(3) Open the springs in the case.

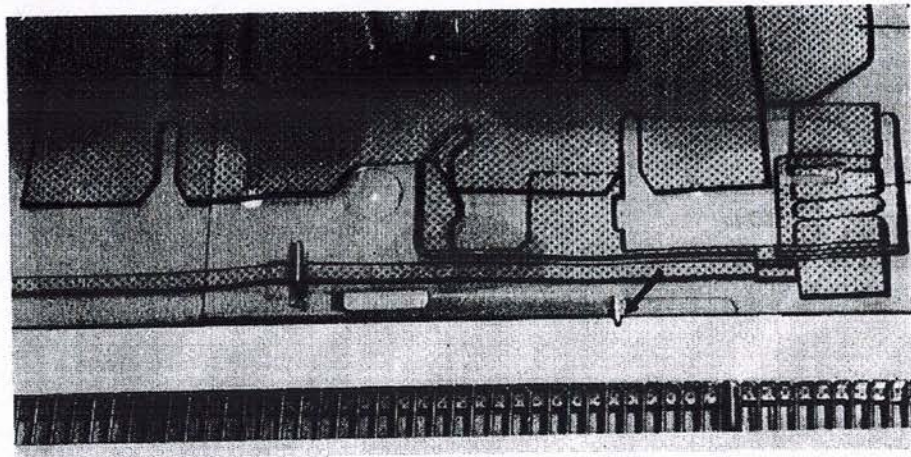

(4) Replace the cast-on comb in the case.

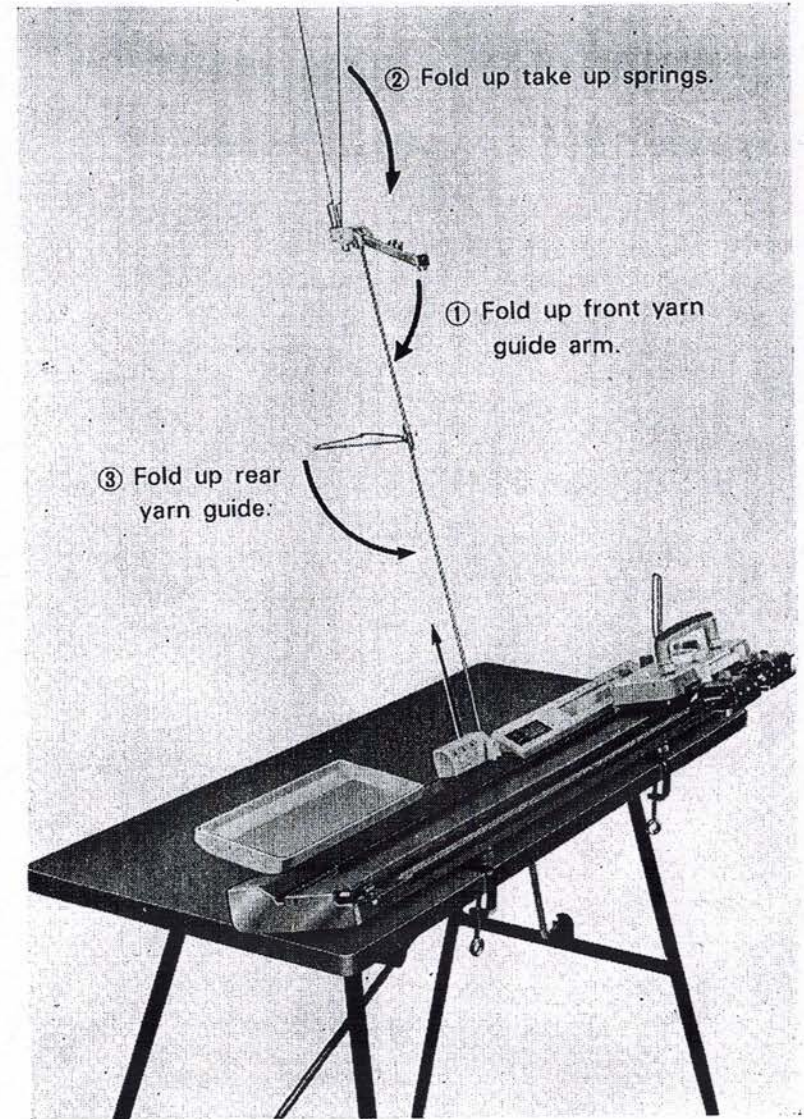

(5) Fold up the automatic yarn tension unit.
Remove the automatic yarn tension unit.

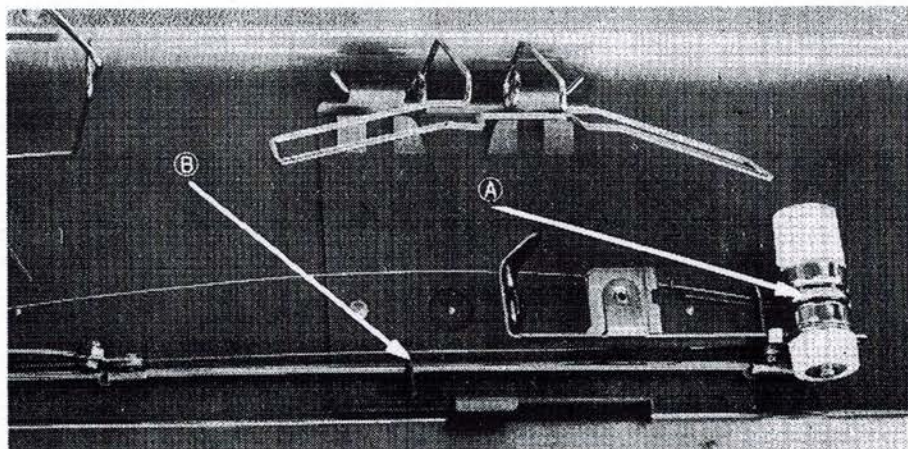

(6) Replace the automatic yarn tension unit as shown in figure. (Fit the head ① of automatic yarn tension unit under the clasp ② of the case.)

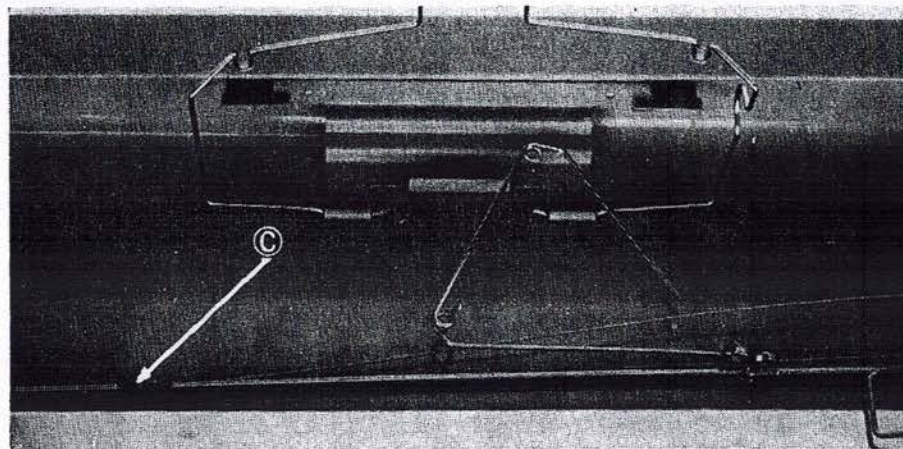

(7) Place the yarn tension rod and the take-up spring beside comb and put them inside of hook ③.

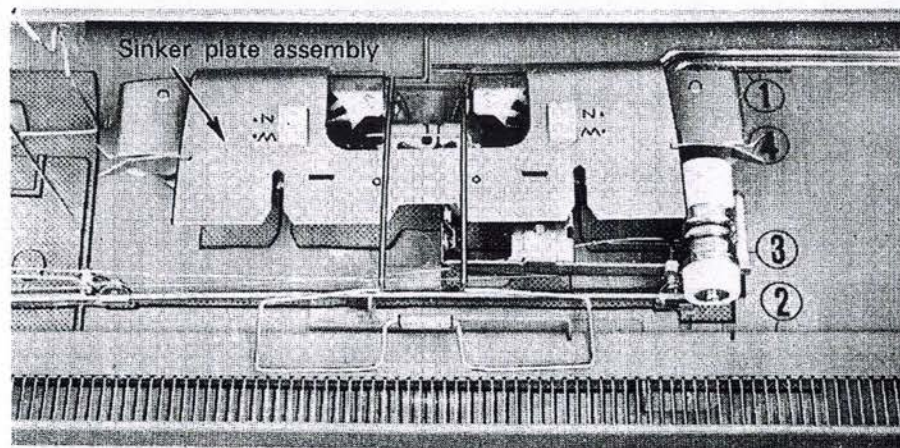

(8) Remove the sinker plate and replace it as shown in figure.

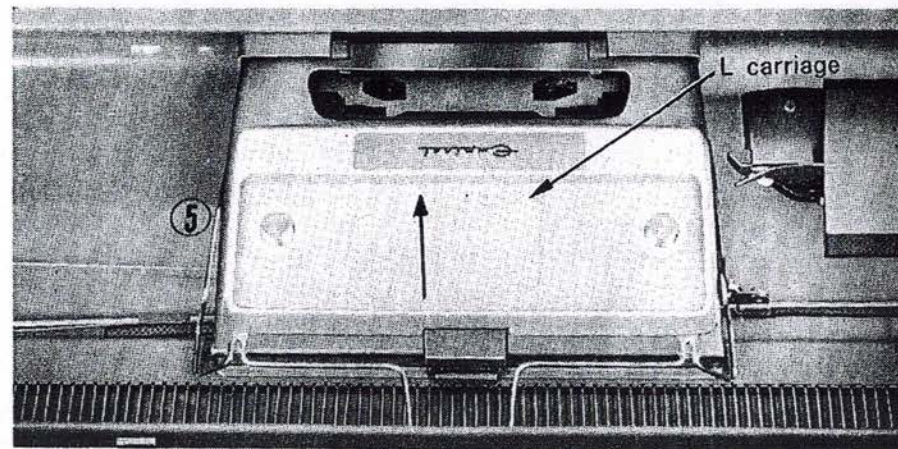

(9) Remove handle from the L carriage and replace the L carriage as shown in figure.

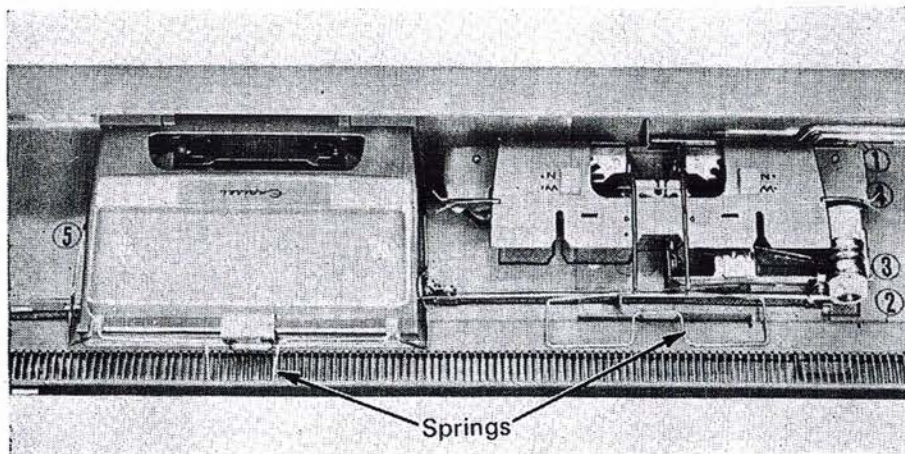

(10) Close the springs.

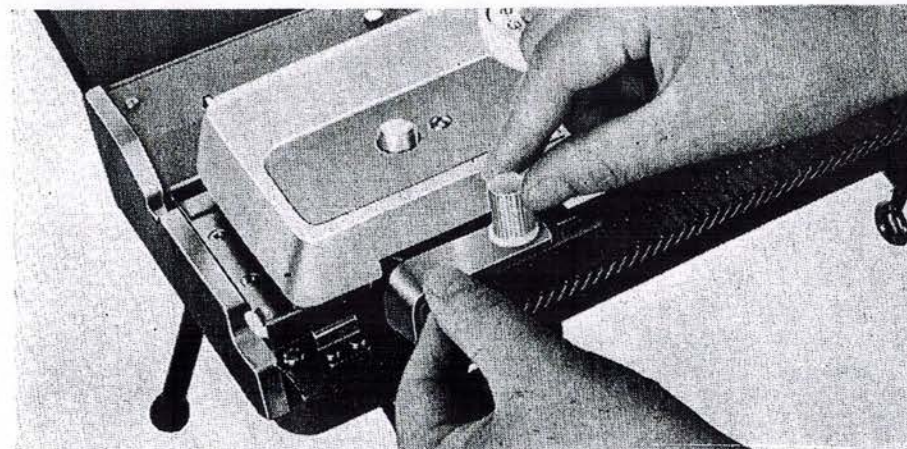

(12) Take out the carriage lock from the accessories box and lock carriage on the left end of the needle bed.

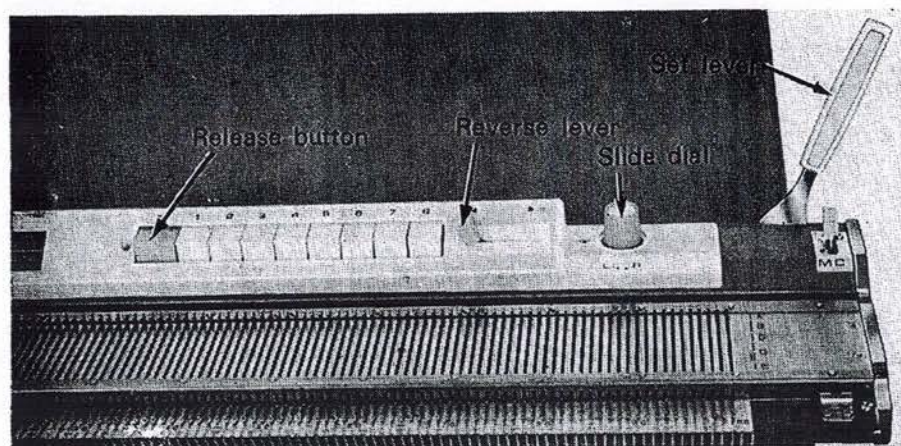

(11) Remove the set lever, push down the release button, set the reverse lever to "+" and push back all needles to position "A".

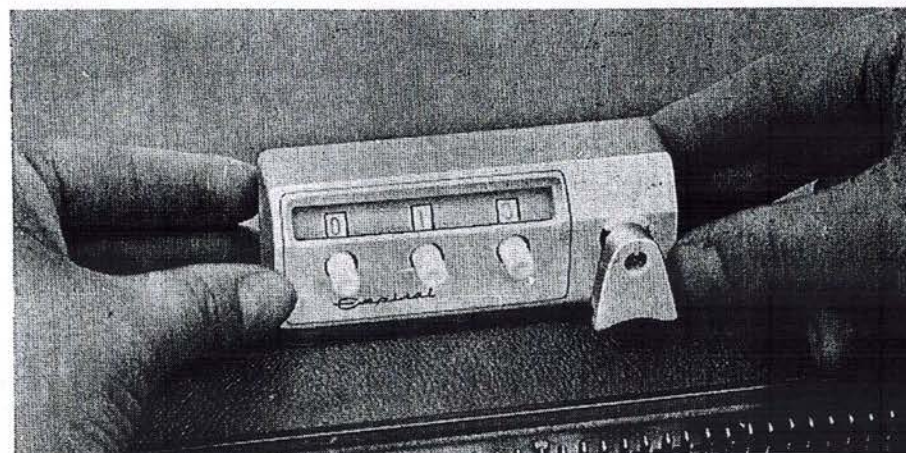

(13) Pull out the row counter.

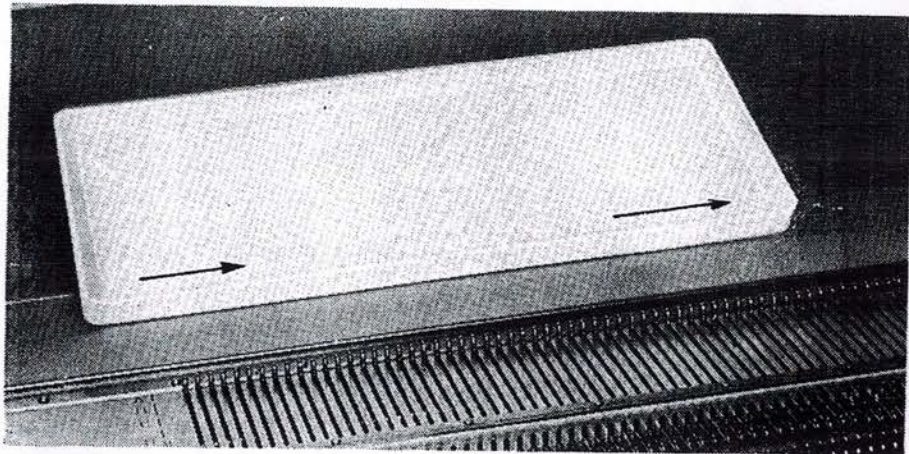

(14) Remove the accessory tray by sliding as indicated by arrows.

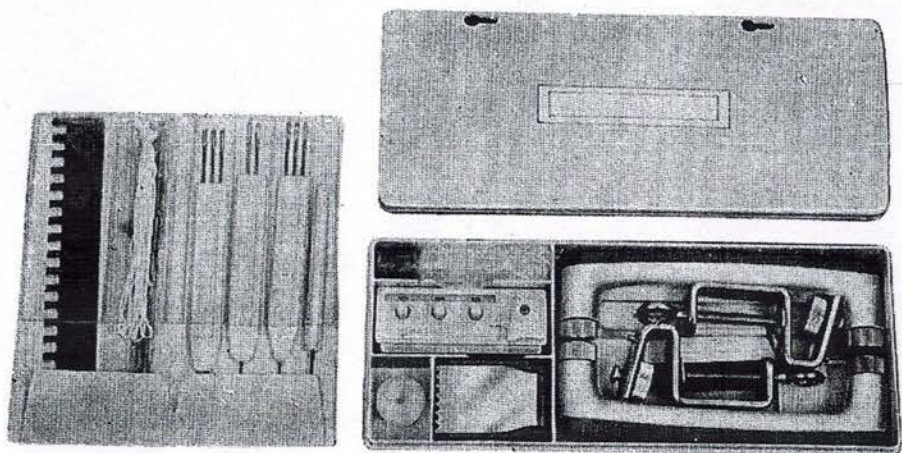

(15) Remove the handle of the carriage, table clamps and set lever.

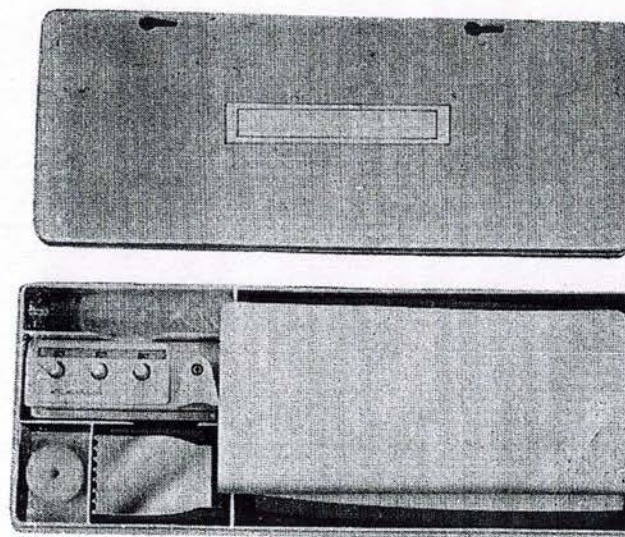

(16) Replace them and other accessories in the accessories box.

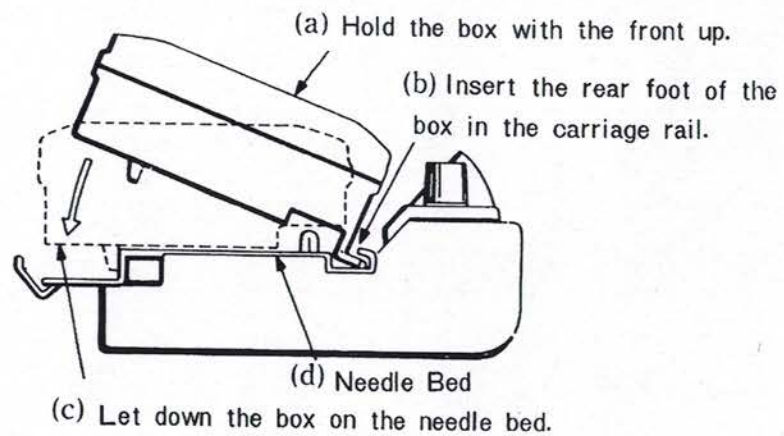

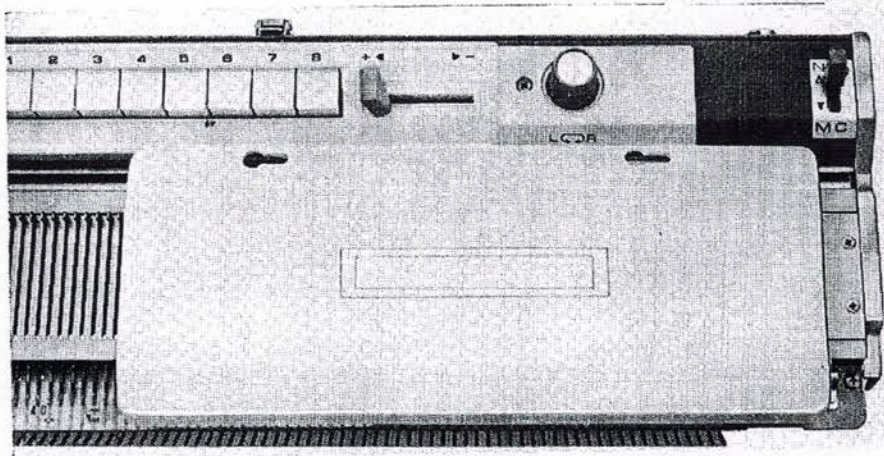

(17) Place the box on the right side of the needle bed.
The left end of the accessories box must be in line
with the number 50 needle.

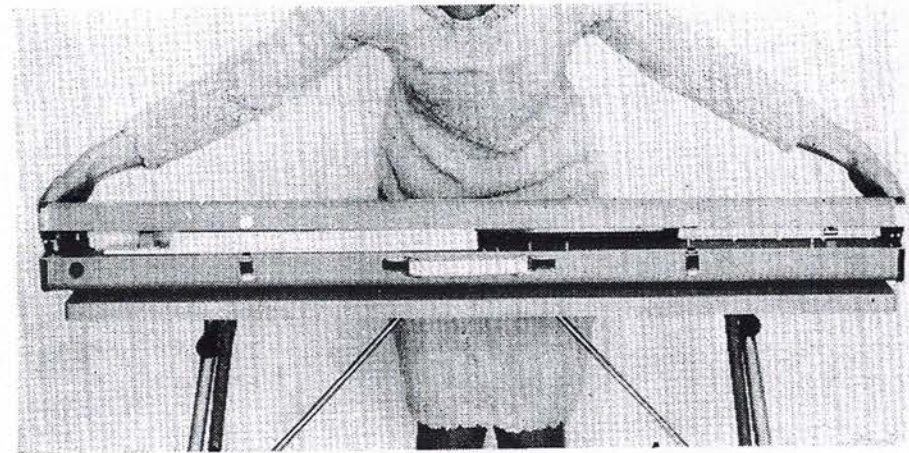
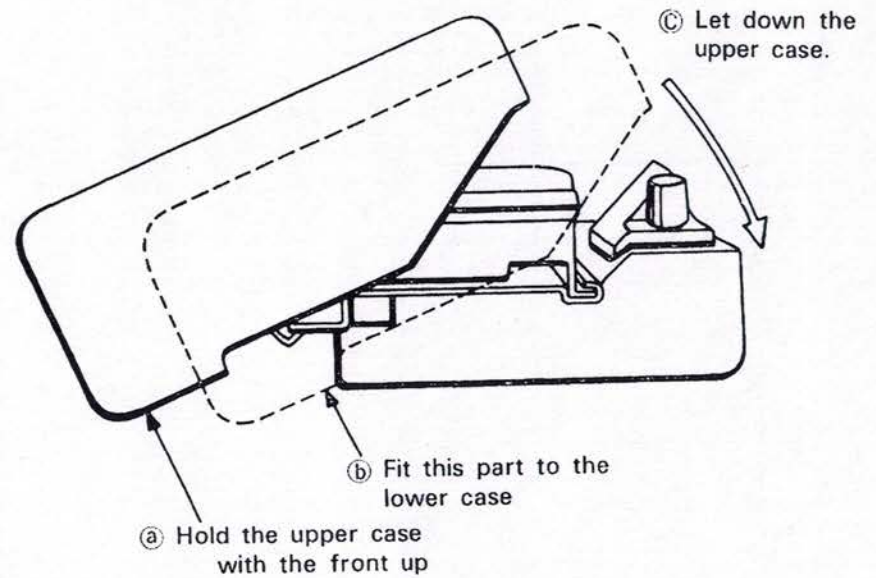
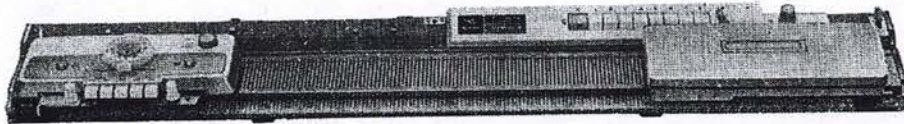

(18) Close the upper case and lock the catches.