

TOYOTA

knitting machines

KS610

Came as SK 151 machine

158389

CONTENTS

	page
MACHINE AND ACCESSORIES	1
SETTING UP THE MACHINE	3
NEEDLE BED AND CARRIAGE	5
YARN PREPARATION	8
THREADING THE YARN	9
YARN AND STITCH DIAL	10
CAST-ON AND KNITTING	11
PATTERN KNITTING	20
Tuck Stitch	21
Tuck Stitch in colours	24
Slip Stitch	26
Slip Stitch in colours	27
Fair Isle (Knit-in)	29
Weaving	31
Intarsia Pattern	33
Plating	36
TAKING A TENSION GAUGE	37
HOW TO USE THE KNIT TRACER (OPTION)	40
HOW TO KNIT A GARMENT	41
KNITTING TECHNIQUES	
Fully fashioned decrease	46
Fully fashioned increase	46
Partial knitting by decreasing stitches	47
Partial knitting by increasing stitches	48
1 × 1 Rib	49
Picot Hem	52
Holding stitches	54
Put the yarn mark	56
Buttonhole	57
Openwork	57
Cable Pattern	58
Garter Stitch	58
Joining on the machine	59
Joining by hand — Blind Stitch	62
Grafting	63
Sew in Yarn Ends	63
Cord knitting	64
Braid	64
HELPFUL HINTS	
To replace a dropped stitch	65
If a dropped stitch has run down for several rows	66
To unravel knitted fabric on the machine	67
If the Carriage has jammed	68
To replace a damaged needle	68
MAINTENANCE	70
REPACKING THE KNITTER	70

MACHINE AND ACCESSORIES

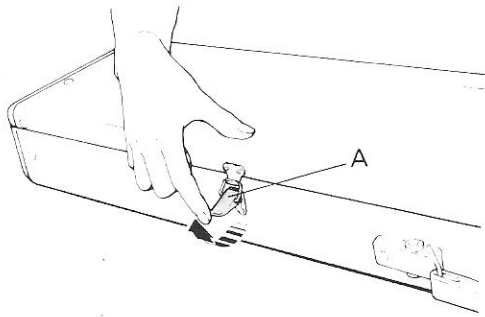

Machine

Place the Knitter on the table with Carrying Handle away from you.

Unfasten the Latches "A".

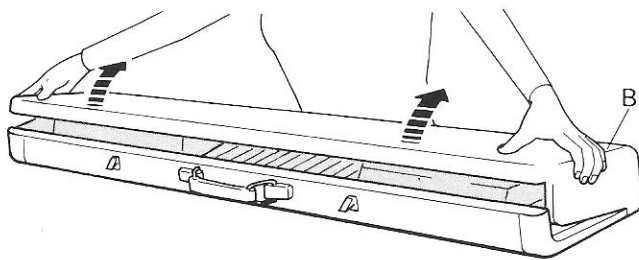

Lift the Top Cover "B" slightly pull it towards you and remove it from the knitter.

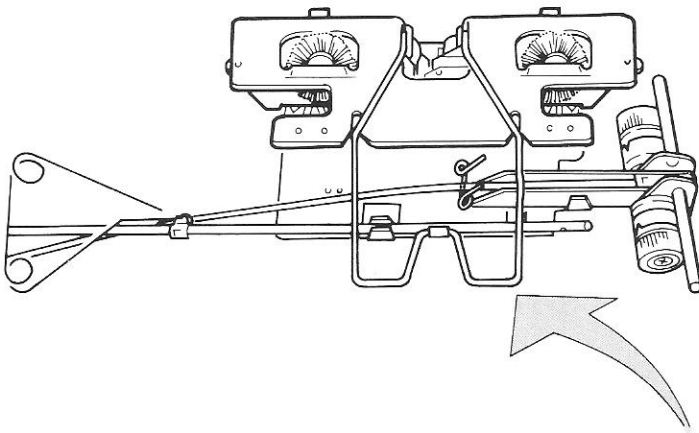

Place the Top Cover as shown below.

Release the wire spring "C" from holding bracket "D" located inside the Top Cover.

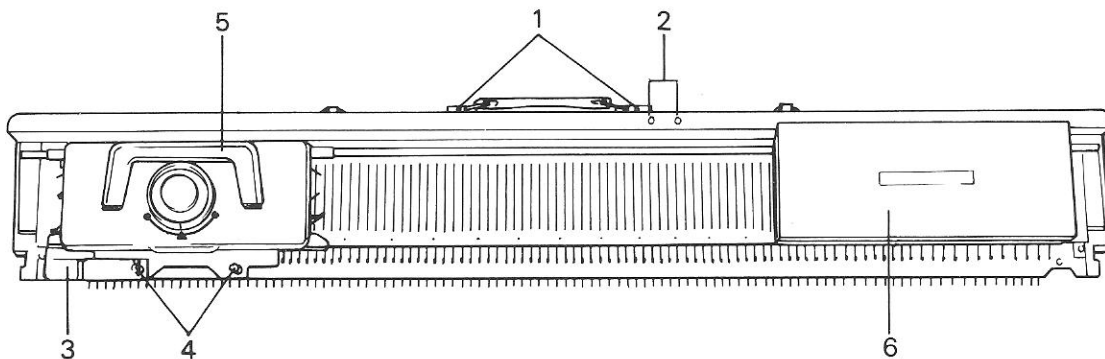
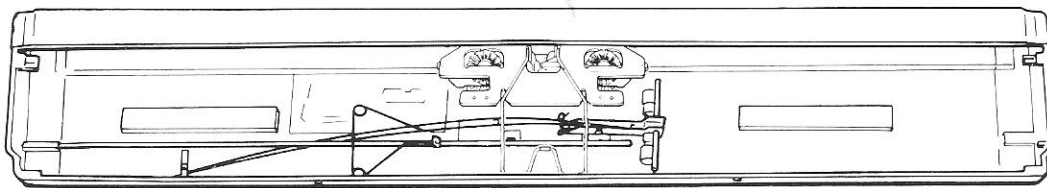

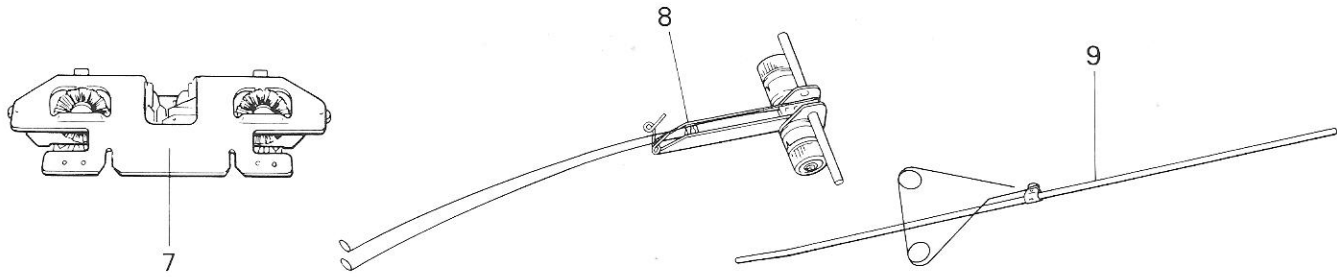

- 1. Bracket Socket
- 2. Row Counter Securing Studs
- 3. Carriage Fastener

- 4. Arm Nuts
- 5. Carriage Handle
- 6. Accessory Box

- 7. Arm
- 8. Auto Tension
- 9. Yarn Rod

Accessories

The following are packed in the accessory box.

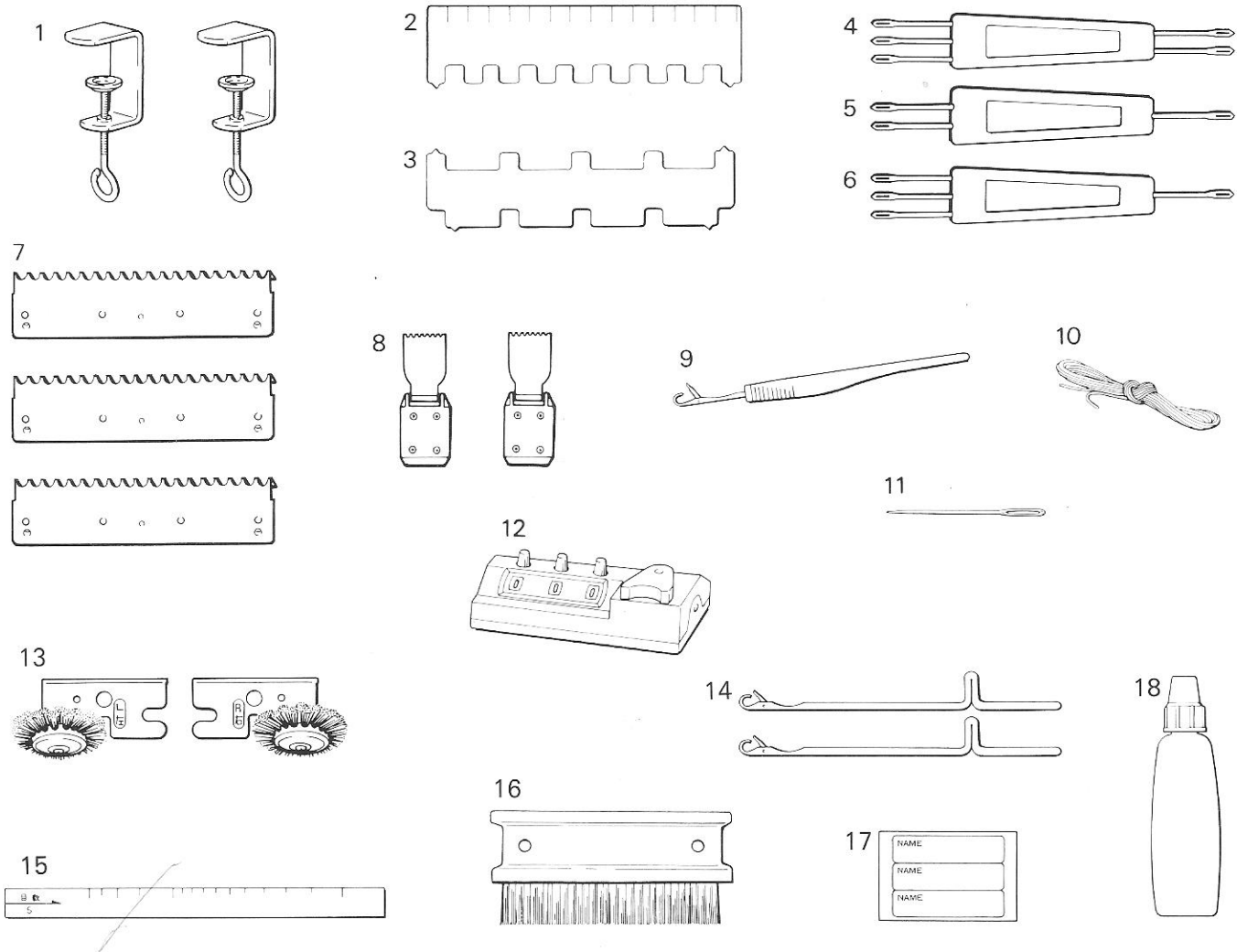

- 1. Clamp
- 2. Needle Pusher (1/1 — 0)
- 3. Needle Pusher (1/3 — 3/1)
- 4. Transfer Tool (2 × 3)
- 5. Transfer Tool (1 × 2)
- 6. Transfer Tool (1 × 3)
- 7. Wide Claw Weight (3)

- 8. Claw Weight (2)
- 9. Tappet Tool
- 10. Ravel Cord
- 11. Tapestry Needle
- 12. Row Counter

- 13. Tuck Brush (left & right)
- 14. Spare Needle (2)
- 15. Gauge Scale
- 16. Cleaning Brush
- 17. Name Paper
- 18. Oil

SETTING UP THE MACHINE

Insert the Clamps into the slots "A" at the bottom of Needle Bed.
Fasten the Clamps by turning in the arrowed direction.

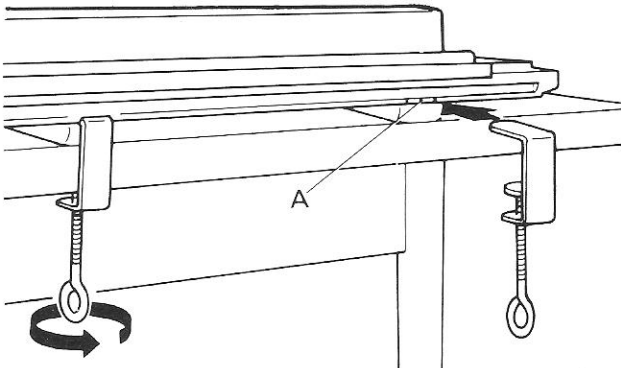

Loosen both Arm Nuts by turning them in the arrowed direction.

Remove the Carriage Fastener.

*Keep the Carriage Fastener in the accessory box.
Use it to keep the Carriage in place whilst moving the machine.*

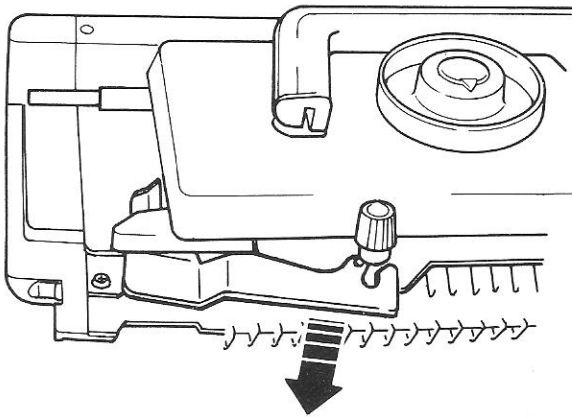

Remove the Arm from the Top Cover and position it under the two Arm Nut screws.

Hold the Arm securely against the Carriage, and tighten the Arm Nuts by turning them in the arrowed direction.

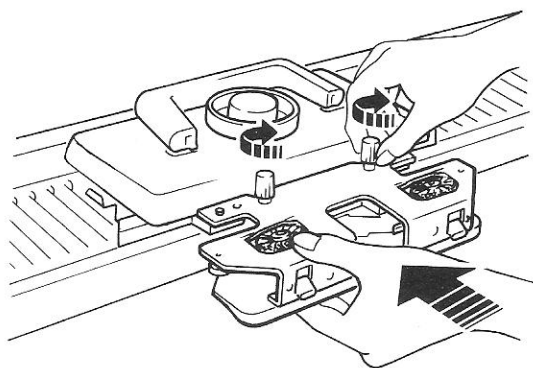

Ensure that the Arm Nuts fit properly into the cut-out of the Arm.

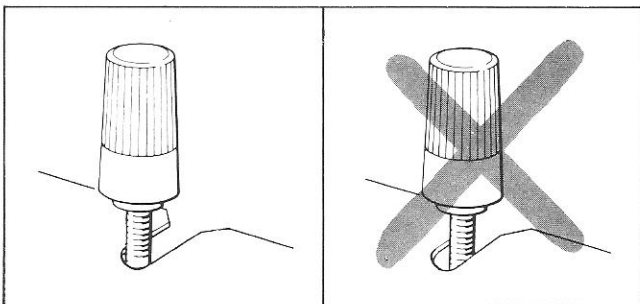

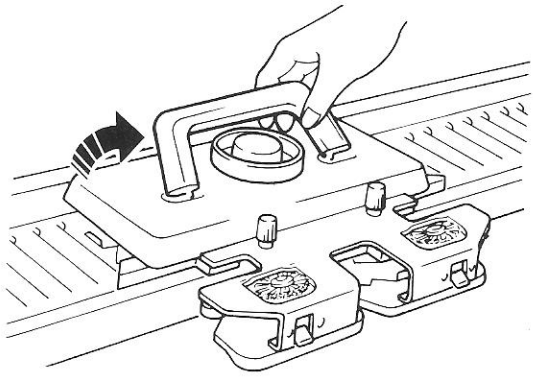

Raise the Carriage Handle, until it clicks into position.

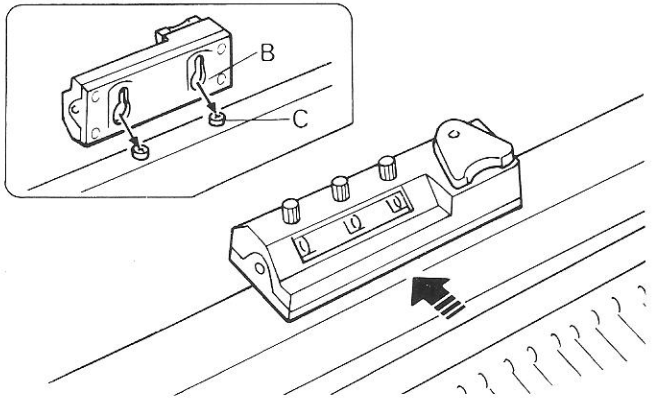

Attach the Row Counter by fitting the slots of the Counter "B" to the Studs "C" on top of the machine.

Remove the Auto Tension and Yarn Rod from the inside of the Top Cover.

Insert the short bend end of the Yarn Rod "D" into either side of the Handle Socket.

Lift the Tension Springs "E" until they click into position.

Fit the Auto-Tension to the top of the Yarn Rod.

Lift the Tension Guide "F"

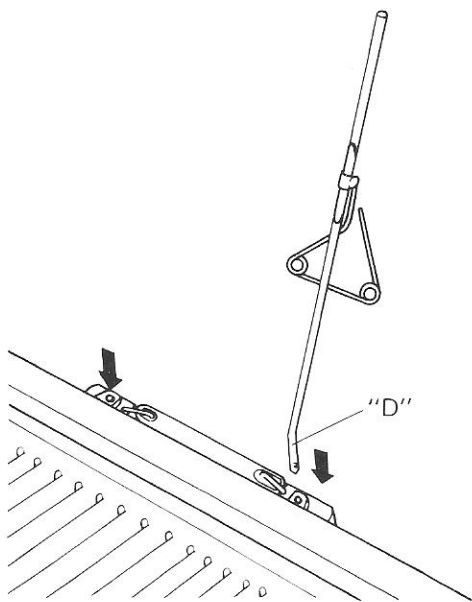
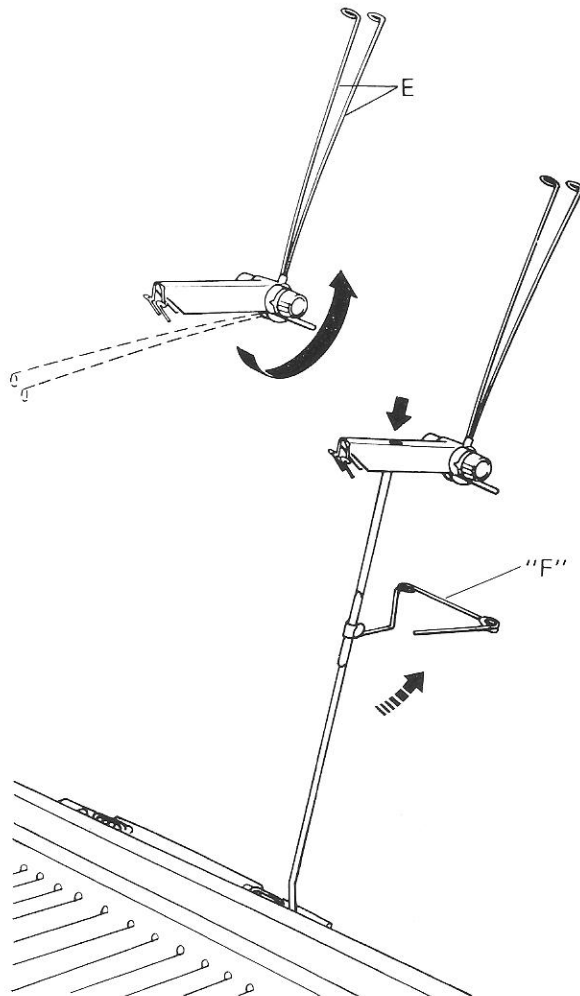

NEEDLE BED AND CARRIAGE

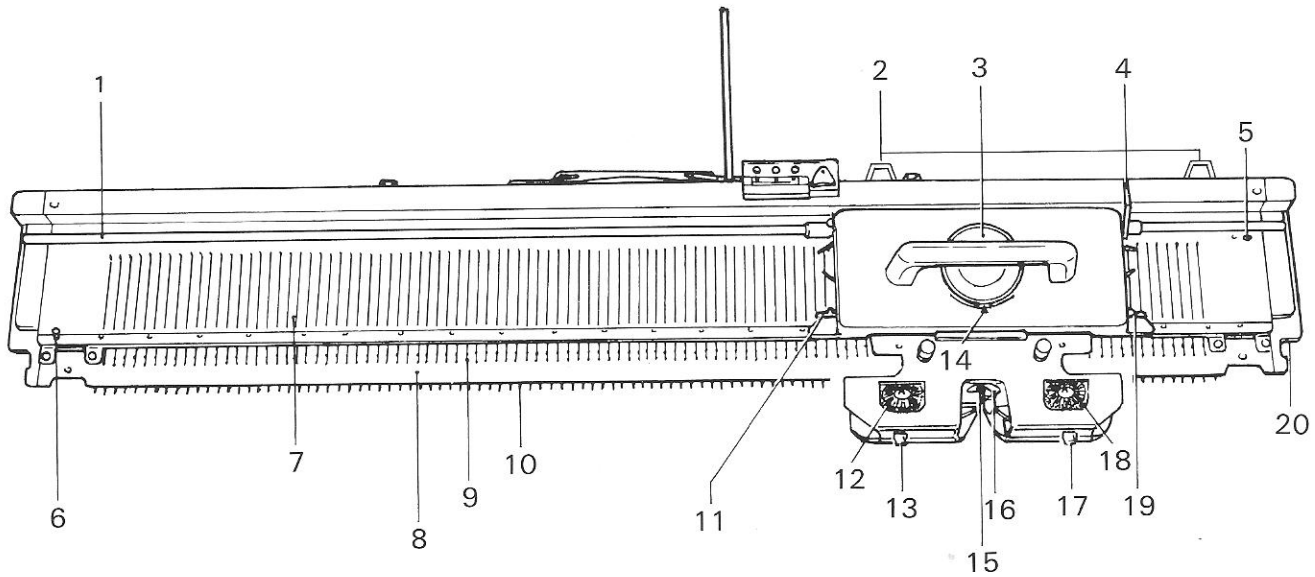

- 1. Rail
- 2. Knit Tracer (option) Securing sockets.
- 3. Stitch Dial
- 4. RC Lever
- 5. Carriage Stopper Pin
- 6. Carriage Stopper Pin

- 7. Needle Bed
- 8. Vinyl Tape
- 9. Latch Needle
- 10. Sinker Post
- 11. Russel Lever (left)
- 12. Weaving Brush (left)
- 13. Weaving Knob (left)

- 14. Pattern Dial
- 15. Main Yarn Feeder
- 16. Plating Yarn Feeder
- 17. Weaving Knob (right)
- 18. Weaving Brush (right)
- 19. Russel Lever (right)
- 20. Yarn Holder



Latch Needle

- A — butt
- B — latch
- C — hook

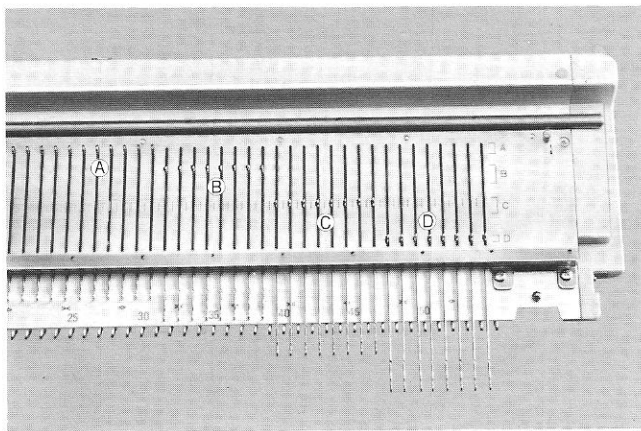

Needle positions

At both left and right ends of the Needle Bed, the letters A, B, C and D associated with brackets "J" are engraved.

To operate the needles, align their butts within the brackets.

- A — Needles do not knit.
- B — Needles knit Plain stitch and stitch patterns.
- C — Needles knit Plain stitch only.
- D — Needles do not knit with Russel Levers at — .
Needles are knitted back to B position with Russel Levers at = .

The numbers 0 — 50 on the left and right of centre(0) indicate number of needles.

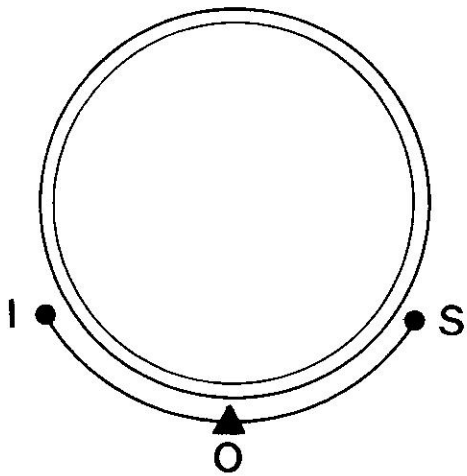

Pattern Dial

Use this to select a stitch type.

Setting positions.

Three positions are marked as shown opposite, and each position is selected by moving the Pattern Dial.

- O — PLAIN STITCH, TUCK STITCH, PLATING, WEAVING.
- S — SLIP STITCH, FAIR ISLE (KNIT-IN)
- I — INTARSIA

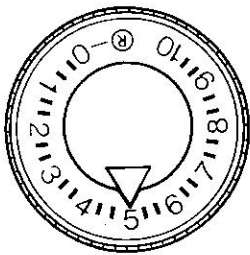

Stitch Dial

Use this to control the size of stitches.

Set the number to the ▽ mark at the front of the Stitch Dial

The higher the number on the Stitch Dial, the larger the stitch size. (the fabric is loose) The lower the number, the smaller the stitch. (the fabric is tight)

Ⓡ is selected when the Ribber KR 310 is attached.

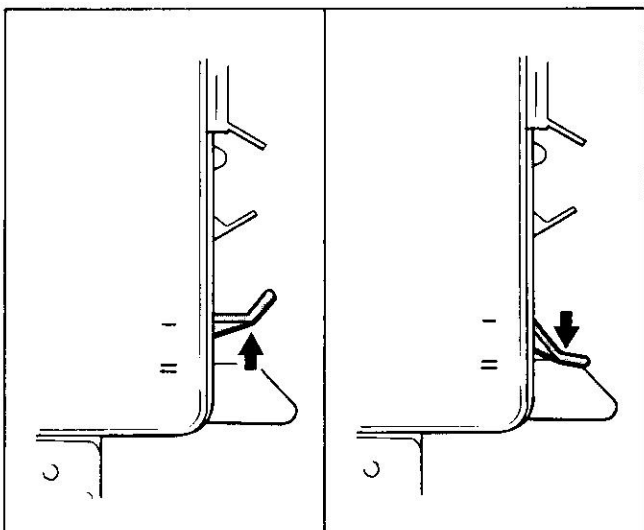
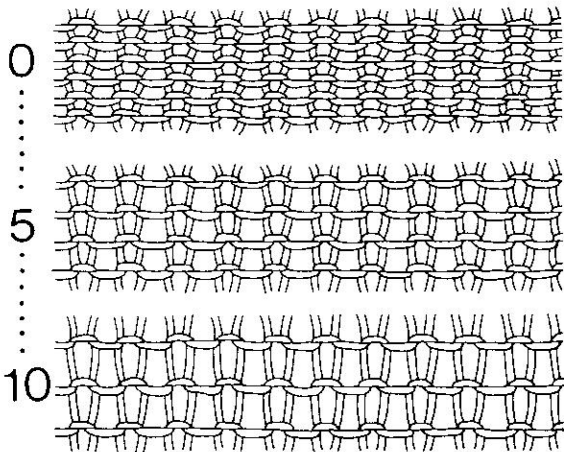

Russel Levers

These control needles in D position.

- — Do not knit the needles in D position.
- ≡ — Knit the needles in D position in Plain stitch

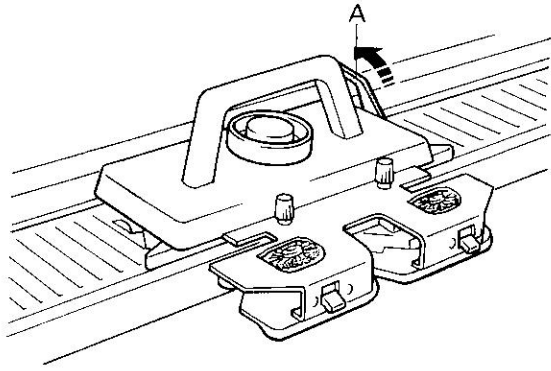

Feeding Levers

The feeding lever "A" (RC Lever) on the right side of Carriage operates both the Row Counter and the Knit Tracer (optional) if it is in use.

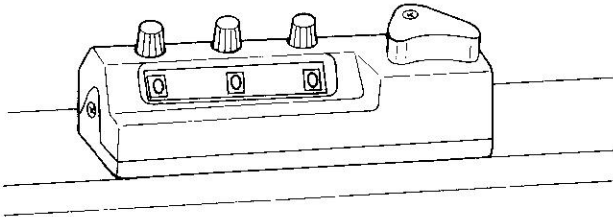

To operate the Row Counter

Raise the RC Lever at the right side of the Carriage. To stop the Row Counter, lay down the RC Lever.

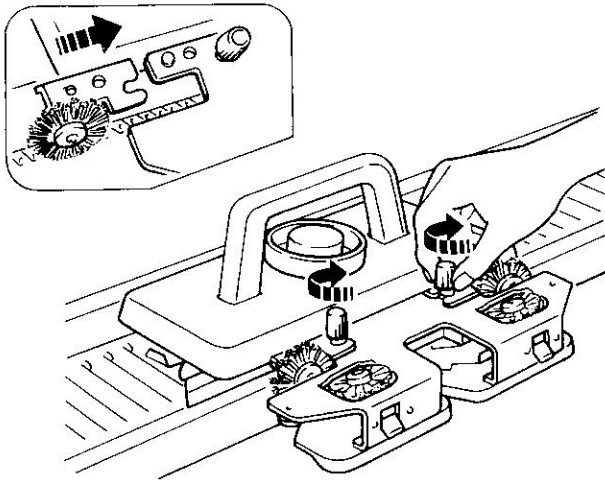

Tuck Brush

Attach the right Tuck Brush at the right side of the Arm and the left Tuck Brush at the left side as shown. Depending on the type of yarn, stitches may be loose on the needles. The Tuck Brushes can be used rectify this, in addition to being used for tuck stitch.

Always remove the Tuck Brushes for Intarsia patterns.

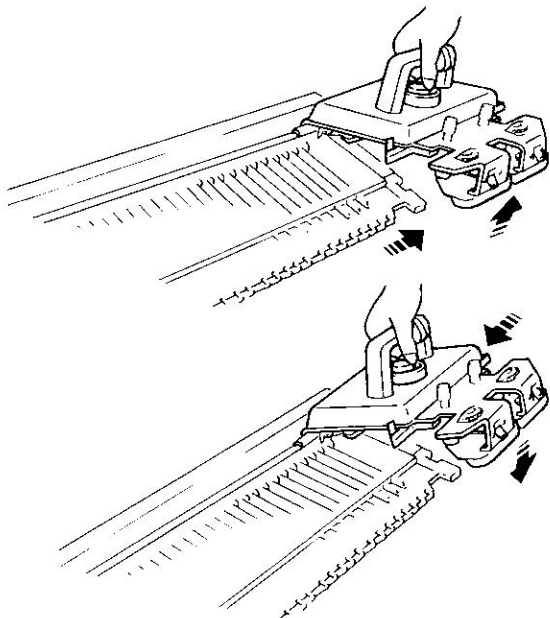

To remove the Carriage from the needle bed.

(with Arm on)

Move the Carriage to either end of the needle bed. Lift the front of the carriage arm to clear the stopper pin and remove from the Needle Bed.

To replace the Carriage on the needle bed.

(with Arm on)

Fit the Rail guide to the needle bed rail. Slide the carriage along the needle bed rail, lifting the front of the arm to clear the stopper pin.

YARN PREPARATION

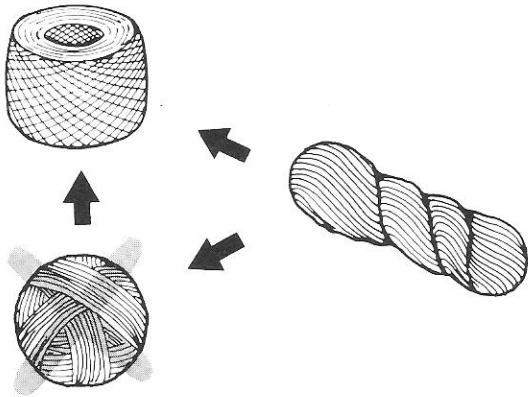

Your machine is designed to knit wide variety of bulky yarns, but it is recommended to use extra thick yarn for practice (see page 10).

Correct preparation of yarns before you start knitting is very important. This will make knitting more enjoyable and easier. The quality of your garment will be much improved.

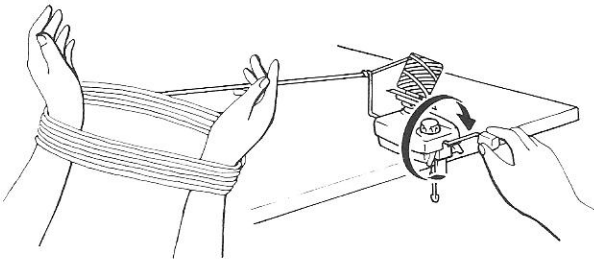

It is impossible to knit from a hank of yarn or hand wound ball.

Open the hank of yarn and place it on your arms (or on an optional Skein Holder) to wind it into a ball, suitable for machine knitting.

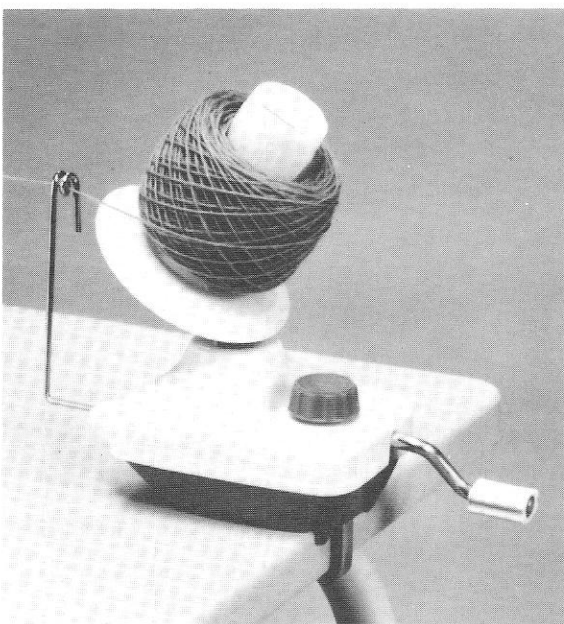
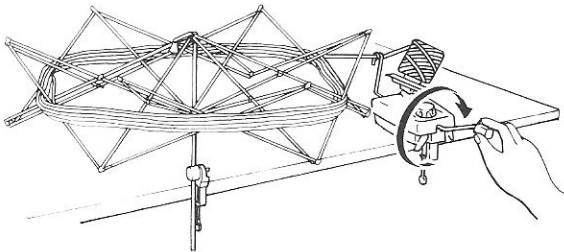

An optional Wool Winder is recommended for winding yarn.

When yarn is rewound, ensure that the yarn end comes out freely without lifting the ball.

If the ball has been wound too tight for the yarn to come out freely, rewind more loosely.

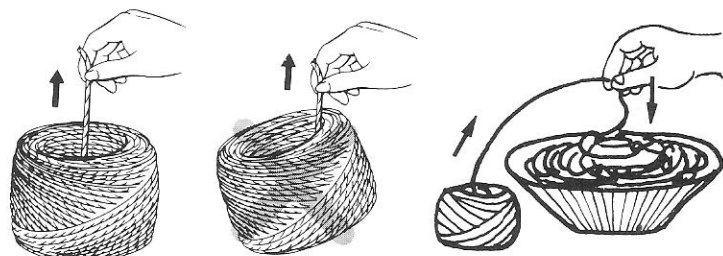

THREADING THE YARN

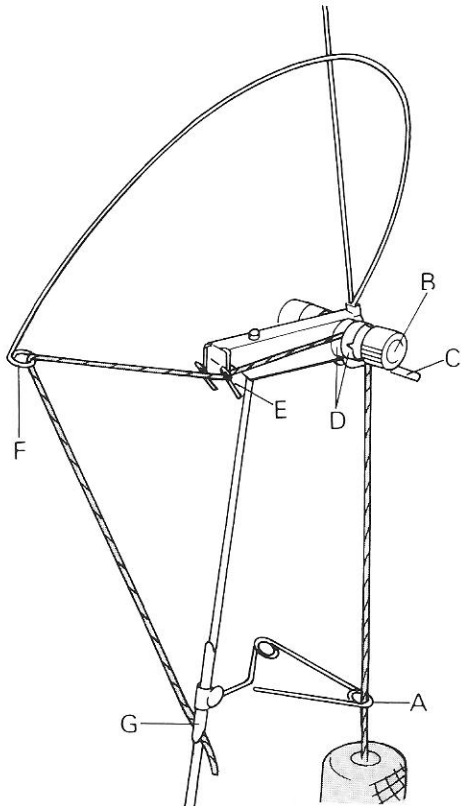

For practice, prepare extra thick yarn.

Thread the right side of Auto Tension as follows:—

- ① through right Tension guide eyelet "A".
- ② between Tension Dial "B" and Guide Bar "C".
- ③ between two Tension Discs "D".
- ④ through right Yarn Guide eyelet "E".
- ⑤ through right Tension Spring eyelet "F".

Put the yarn end under Yarn Clip "G".

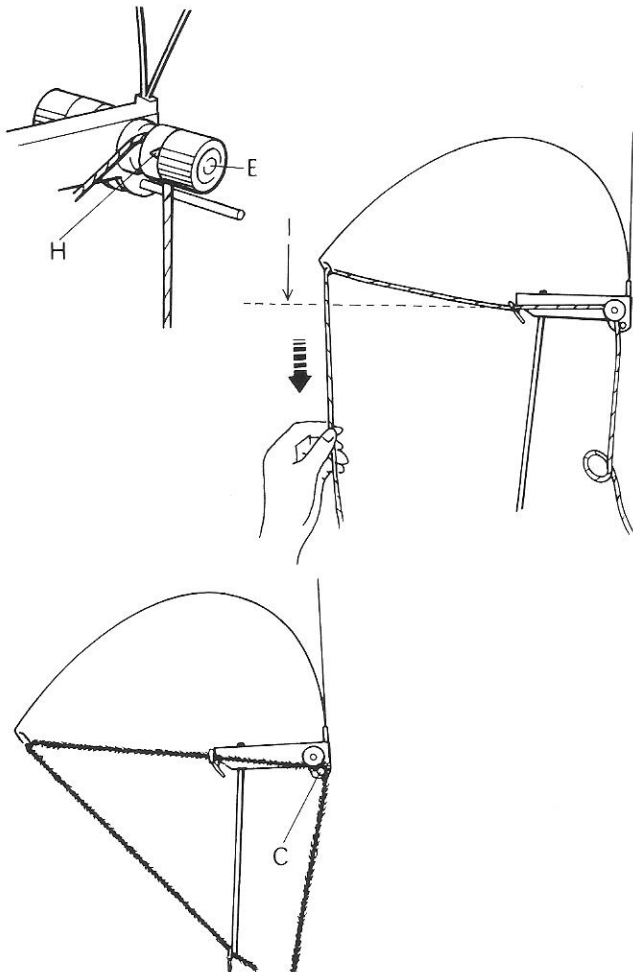

Adjusting Tension Dial

Adjust the Tension Dial according to type of yarn by turning the Tension Dial "B" until a required number corresponds to the < shape "H" using the following as a guide:—

1. Yarn comes out freely from the yarn ball.
2. Distance between the Tension Spring and the horizontal line "I" — 10—20cm. must be maintained.

The higher the number, the tighter the tension. The lower the number, the looser the tension.

If you use heavy weight slub yarn, place it on the Guide Bar "C" only, not between tension discs.

It is advisable to pull out a length of yarn from the yarn ball before casting on.

YARN AND STITCH DIAL



To obtain suitable stitch size, or suitable tension for a garment, set the Stitch Dial Number according to the thickness of the yarn, referring to the yarns and the table opposite.

TYPE OF YARN	STITCH DIAL
① Medium thick	1 – 2
② Mohair	3 – 4
③ Very thick	5 – 6
④ Extra thick	6 – 8
⑤ Super extra thick	8 – 10
⑥ Super extra thick (every second needle)	6 – 7

The thicker the yarn, the higher the Stitch Dial Number, and the thinner the yarn, the lower the Stitch Dial Number.



Ⓐ — Stitch Dial at 1 with medium thick yarn.

Ⓑ — Stitch Dial at 5 with very thick yarn.

Ⓒ — Stitch Dial at 9 with super extra thick yarn.

CAST-ON AND KNITTING

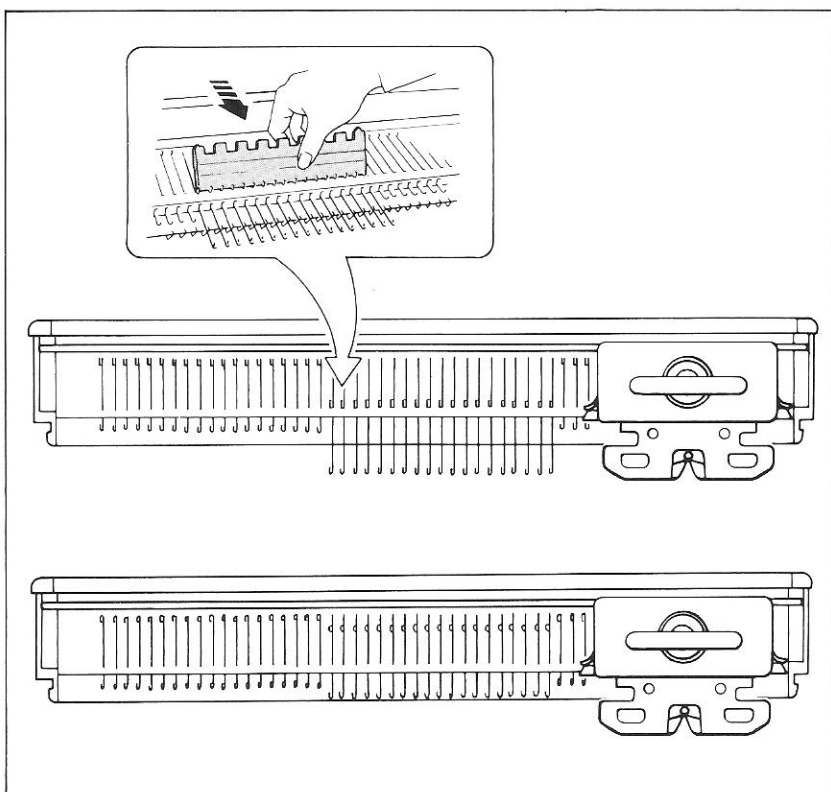

Cast-on

Push the required number of needles from A position to D position using flat side of the Needle Pusher.

Set the Carriage as shown below.

Pattern Dial..... 0

Russel Levers..... =

Weaving Knobs..... O

Slowly move the Carriage across the Needle Bed until it has passed all needles in D position.

The needles align in B position. Return the carriage to the right side of the needle bed.

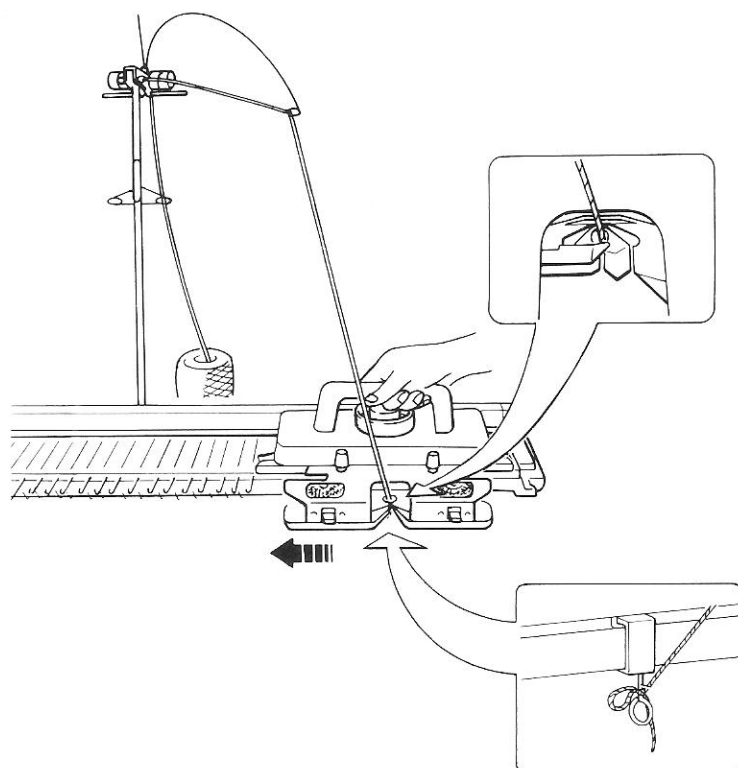

(1) Using Ravel Cord

Set the stitch dial referring to the table on page 10.

Remove the yarn end from Yarn Clip and bring it down to the Carriage.

Hold the yarn with both hands and slide it into the Yarn Feeder.

Fasten the yarn end to the clamp nearest the Carriage.

Eliminate slack yarn by pulling the yarn down at the back of Yarn Rod.

Slowly move the Carriage from right to left until it has passed all the needles in B position.

Be sure to take the Carriage past the last knitting needle by 2—3cm.

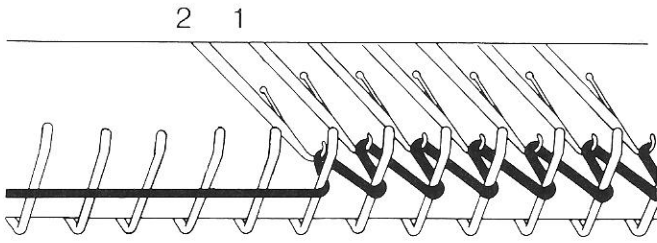

Even loops have been formed between needle hooks "C" and sinker posts "D"

When knitting the first row, the loops may get smaller towards the edge.

To achieve a successful cast-on, these smaller loops must be increased in size.

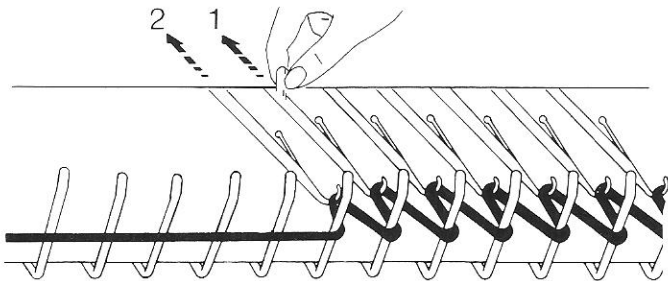

To correct, hold yarn above the Yarn Feeder and pull it down to allow some slack.

Starting with needle "1", push the needles with small loops one by one back to B position.

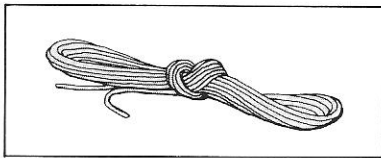

Take the Ravel Cord from the accessory box, and undo it. Make sure that there are no knots in the cord.

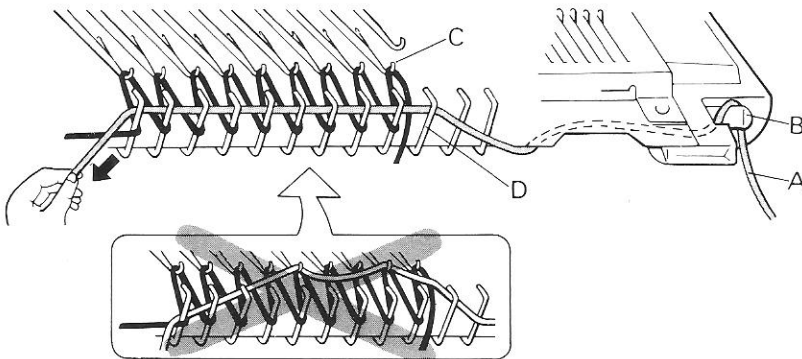

Place the end of the Ravel Cord "A" in the yarn holder "B" at the right end of needle bed as shown. Lay the Ravel Cord across the yarn loops between needle hooks "C" and sinker posts "D".

Pull the Ravel Cord with the left hand.

Ensure that the Ravel Cord lies across the loops and is not caught in the needle hooks.

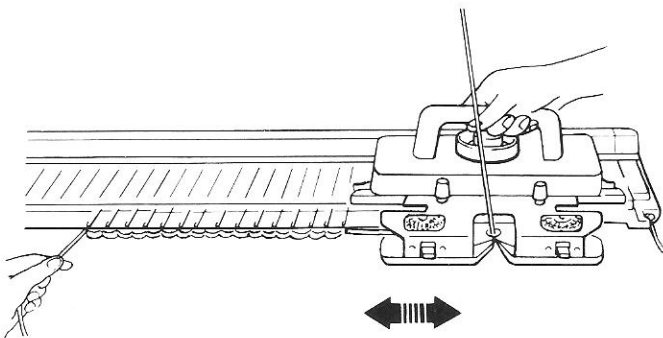

While pulling down the left end of the Ravel Cord, move the Carriage to the right side.

Continue to knit 5 — 6 rows.

Release the end of the Ravel Cord from the yarn holder and pull it out from the left.

Unfasten the yarn end from the clamp.

Cast-on has been finished.

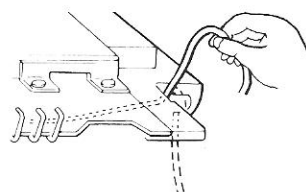
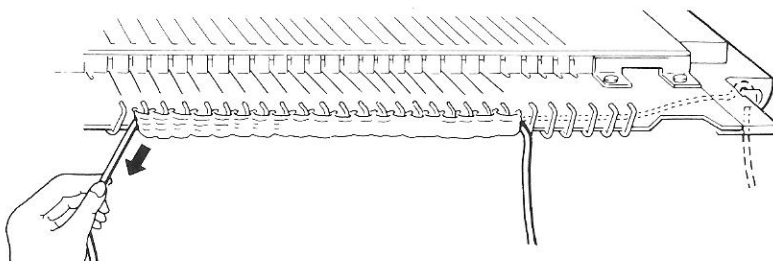

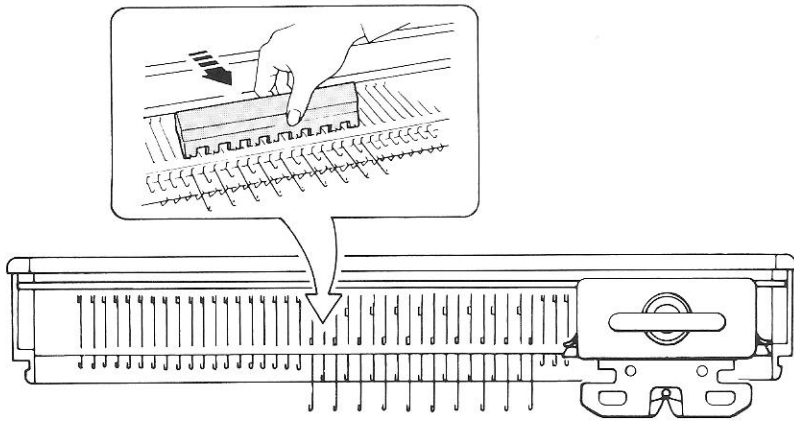

(2) Weaving method

Set the Stitch Dial referring to the table on page 10.

Weaving Knobs.....~

Push every alternate needle from B position to D position using 1/1 side of Needle Pusher.

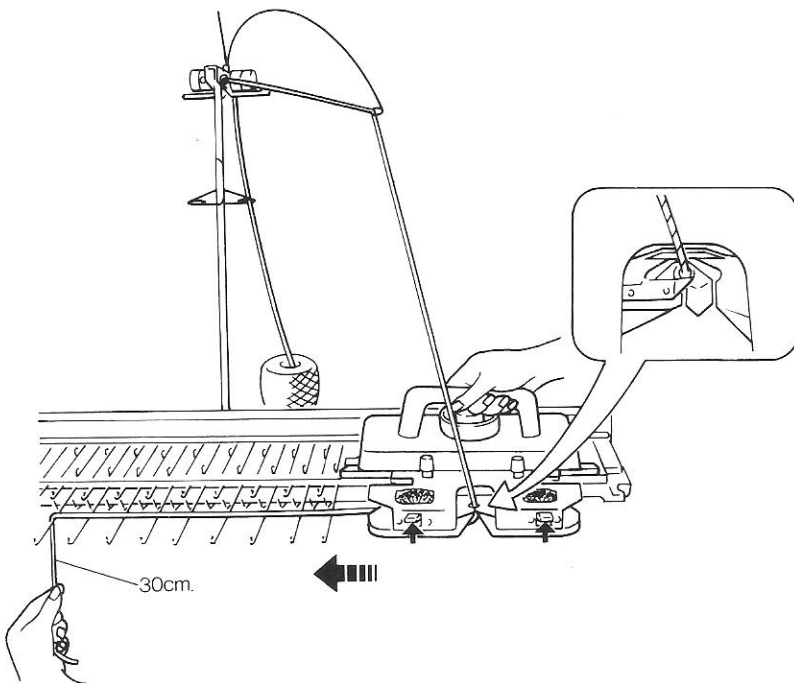

Remove the yarn from the Yarn Clip and place it into the Main Yarn Feeder holding the yarn with both hands.

Pull the yarn end from underneath the Arm and lay it over all needles in D position, in front of the sinker posts.

Hold the yarn loosely at left about 30cm. from the yarn end.

Eliminate Slack yarn by pulling the yarn down at the back of Yarn Rod.

Slowly move the Carriage from right to left until it has passed all the needles, knitting 1 row.

Ensure that the Arm has passed the last knitted needle by approximately 2 — 3cm. before beginning the next row.

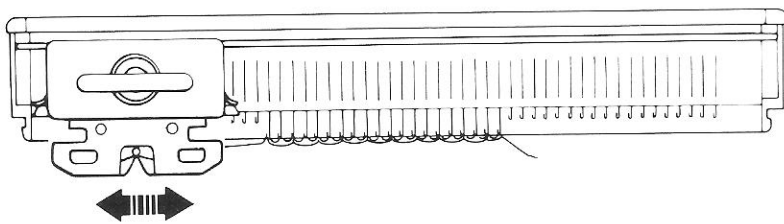

Continue to knit 2 — 3 rows. Cast-on has been finished.

Set the Weaving Knobs at O.

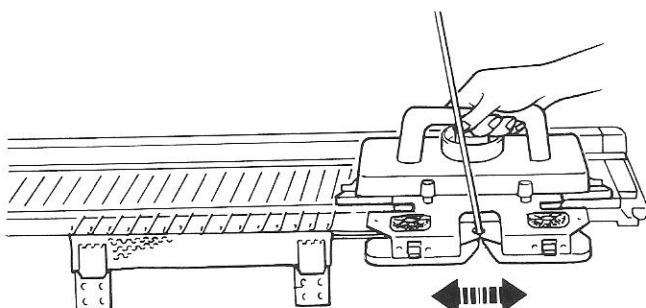

Knit 4 — 5 rows and hang Claw Weights at both ends of the fabric.

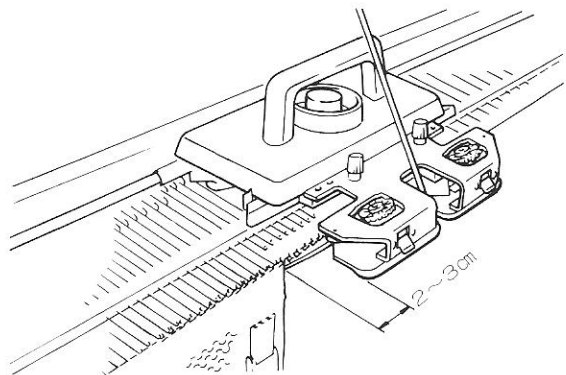

Plain Stitch

Pattern Dial 0
 Weaving Knobs..... ○

Move the Carriage from side to side.

Ensure that the Arm has passed the last knitted needle by approximately 2 ~ 3cm. before beginning the next row.

How to use Ravel Cord

Use the Ravel Cord to separate the main yarn and waste knitting when making a hem.

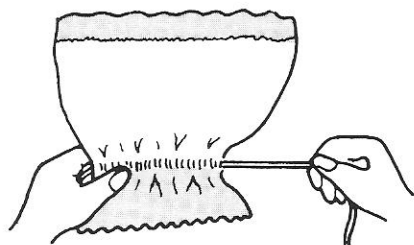
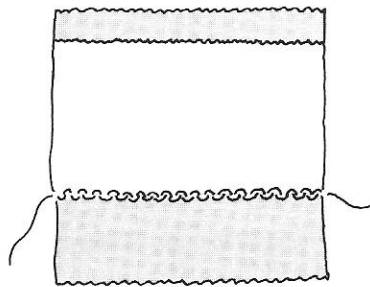

After the garment piece has been finished, pull out the Ravel Cord.

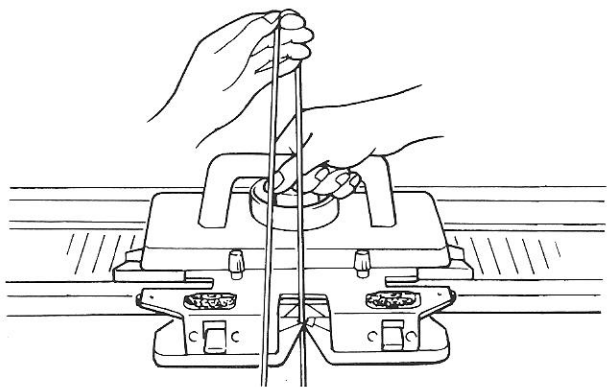

To knit in the Ravel Cord, place it in the Main Yarn Feeder. Hold the Ravel Cord between the thumb and forefinger lightly above the Yarn Feeder, and move the carriage slowly.

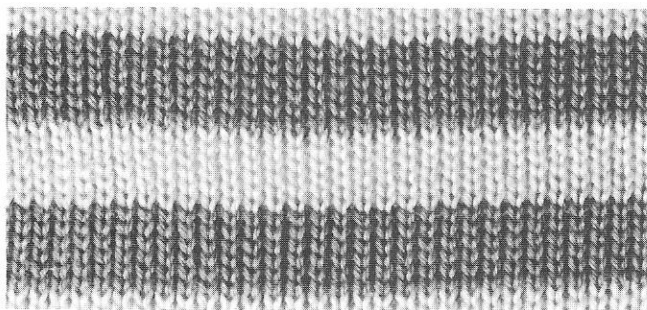

Knitting Stripe Pattern

Knit stripes by changing the yarn in the main yarn feeder every few rows.

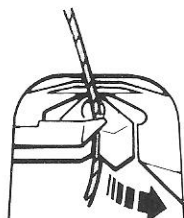

Remove main yarn from the Yarn Feeder.

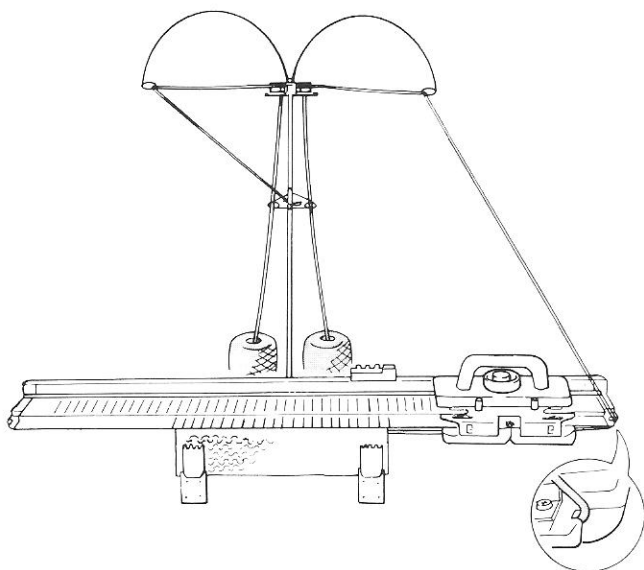

Place the main yarn in the yarn rest at the side of Needle Bed.

IMPORTANT

The yarn in the left Tension Spring must always be placed in the yarn rest at the left end of the needle bed and the yarn in the right Tension Spring in the right yarn rest.

You must always rest the yarn at these ends of needle bed, no matter which side you change yarns.

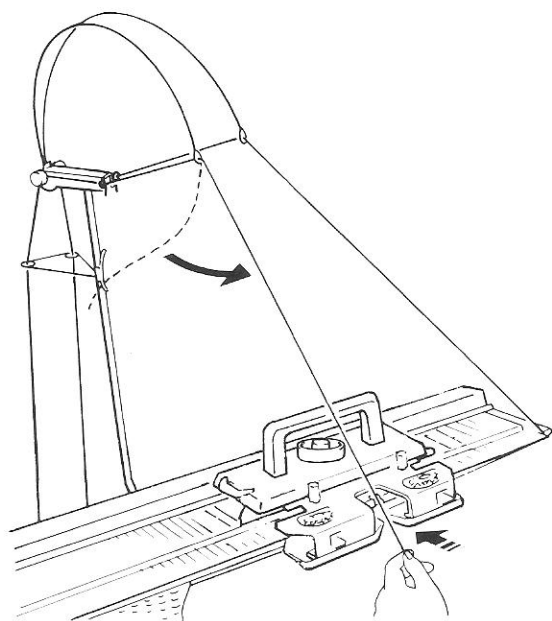

Remove the second colour yarn from the Yarn Clip and place it in the Main Yarn Feeder.

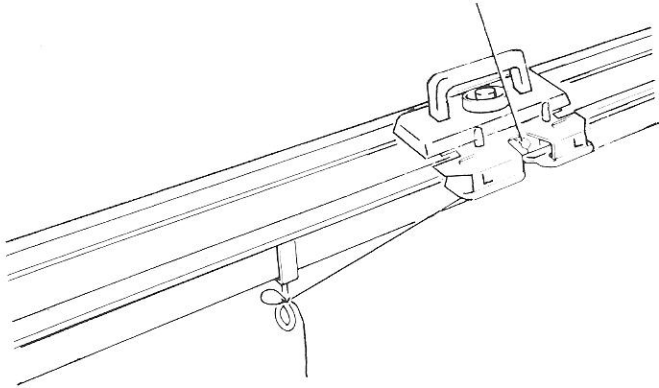

Fasten the yarn end to either Clamp.

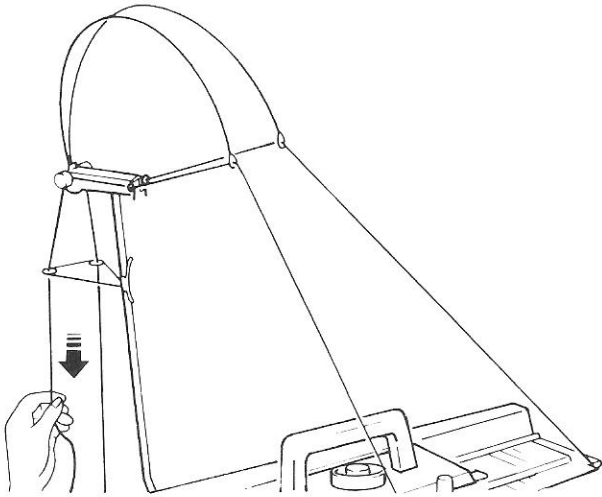

Eliminate slack yarn by pulling the yarn down at the back of Yarn Rod.

Knit an even number of rows.

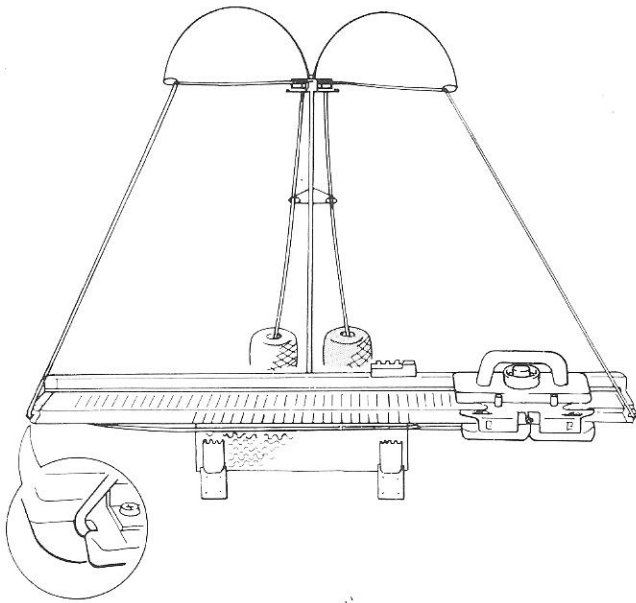

Remove the second colour yarn from Yarn Feeder and place it in the empty yarn rest.

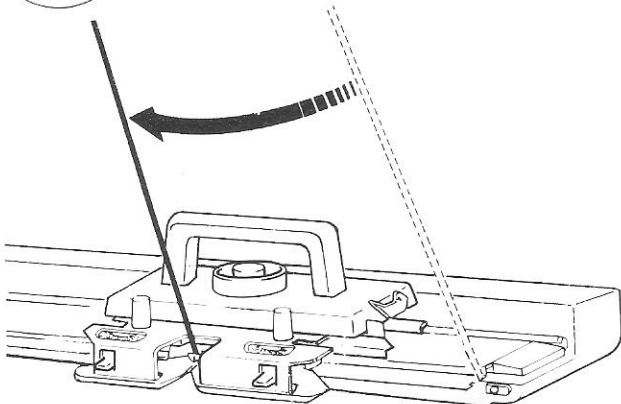

Remove the main yarn from the yarn rest and place it into the Yarn Feeder.

Knit an even number of rows using yarns alternately.

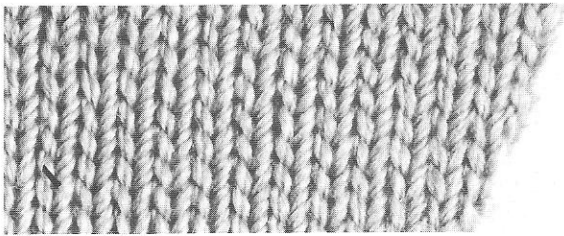

INCREASING 1 STITCH

You can increase 1 stitch at a time only on the Carriage side of the knitting.

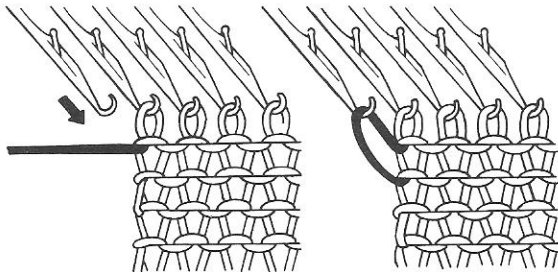

Push 1 needle at the Carriage side from A to B position.

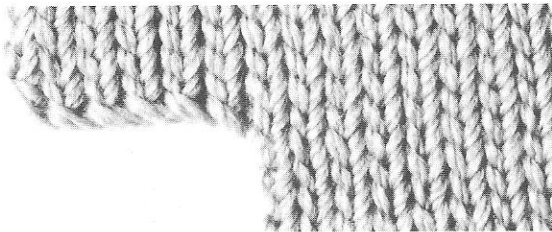

INCREASING MULTIPLE STITCHES

You can only increase on the Carriage side.

When the Carriage is at right side:—

Russel Levers at = .

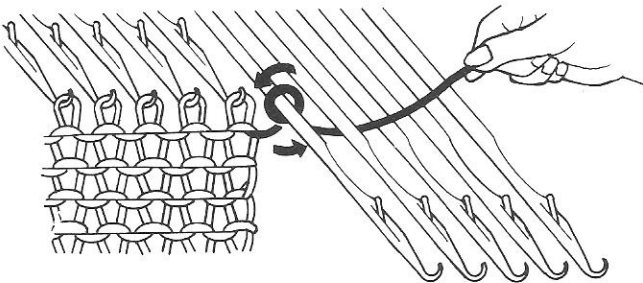

1. Push the required number of needles from A to D position. Pull some yarn from the Yarn Feeder and wind it loosely around the empty needles in the anti-clockwise direction.

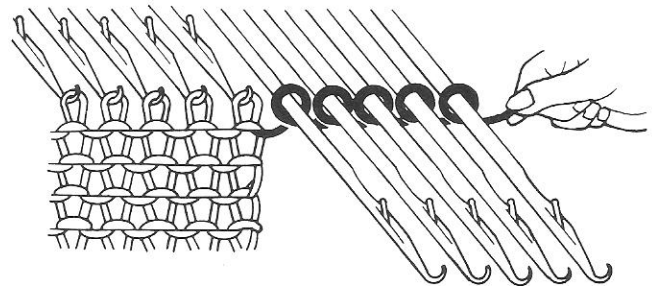

- 2: Push loops against sinker posts, eliminate slack yarn, and continue knitting.

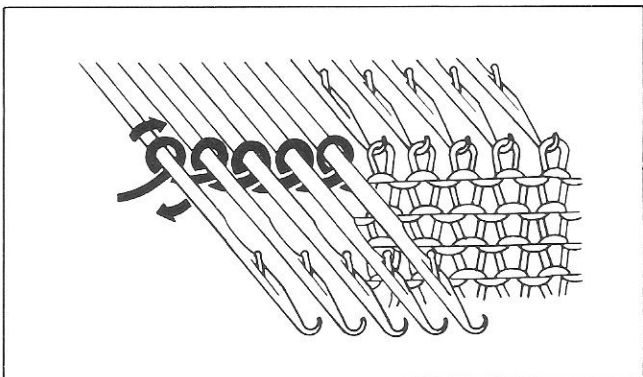

When the Carriage is at the left side, wind yarn around the needles in the clockwise direction.

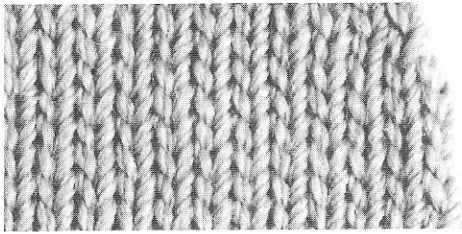

DECREASING 1 STITCH

You can decrease 1 stitch at both sides of the row simultaneously.

Using the Transfer Tool, transfer the end stitch onto the adjacent needle.

Push the empty needle to A position.

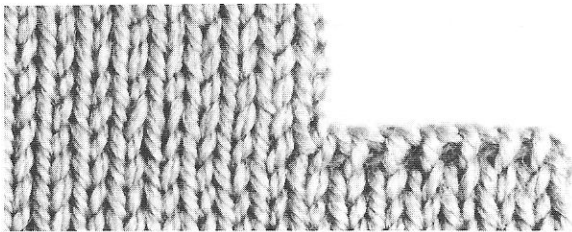
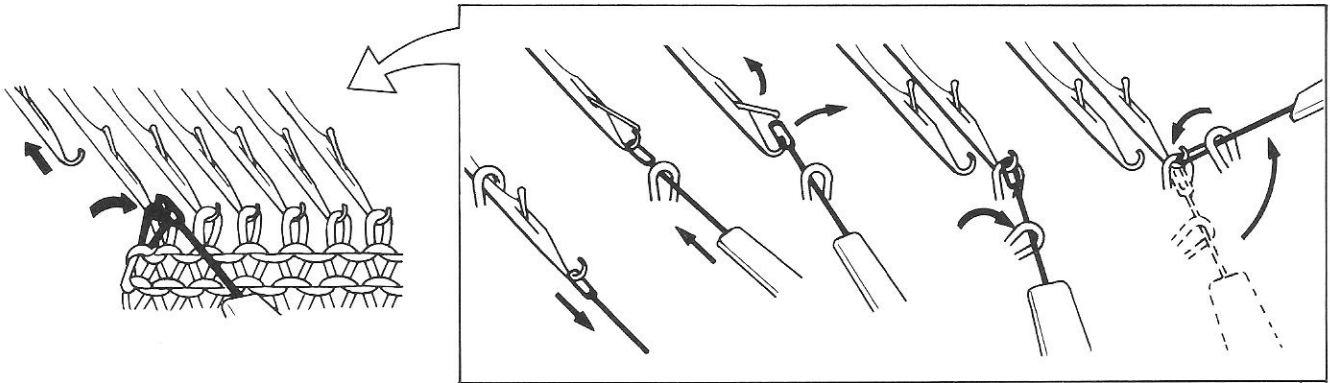

DECREASING MULTIPLE STITCHES

You can decrease only on the Carriage side.

To decrease at the left edge.—

1. With the Carriage at the left, hold the fabric back towards the Knitter.
Transfer the end stitch to adjacent needle. Push the empty needle to A position.
2. Push the second needle to D position until both stitches are behind the latch.
3. Lay yarn from left to right inside the open hook of the needle.
(When decreasing at the right edge, lay yarn from right to left)
4. Hold yarn slightly down and push the needle back to B position.
The two stitches slip off the needle leaving a new stitch.
5. Continue the same procedure until the required number of stitches have been decreased.
Place the last decreased stitch onto its adjacent needle.

* Repeat in reverse to decrease at the right.

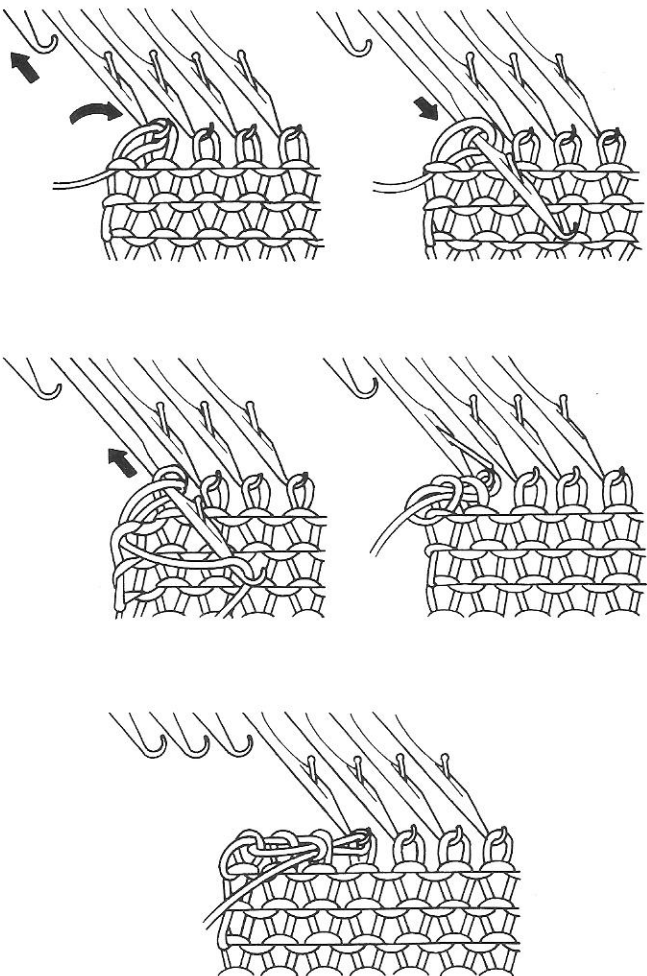

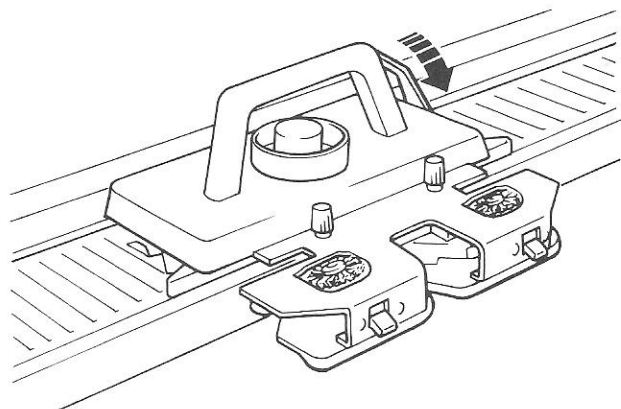

Moving the Carriage without knitting.

Turn the Feeding Lever toward you to non-working position.

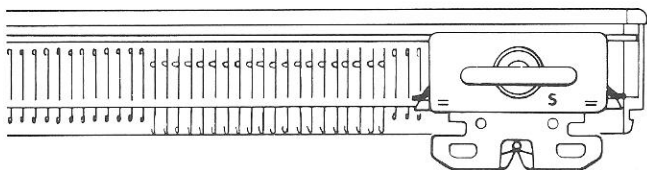

With the needles in B position.

— Set the Pattern Dial to "S" and move the Carriage.

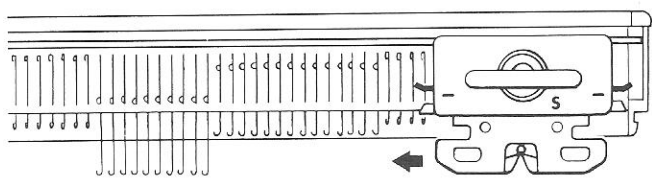

With the needles in B and D position.

— Set the Pattern Dial to "S" and Russel Levers to —, and move the Carriage.

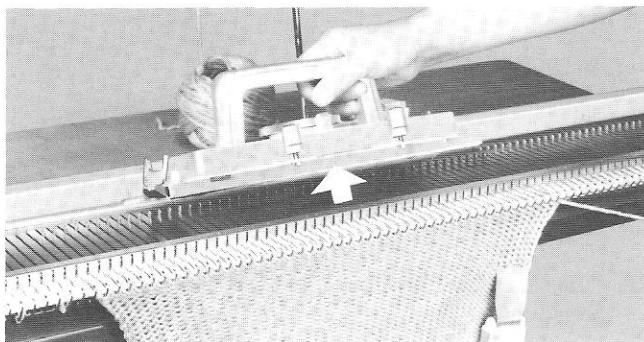

In any needle position, remove the Arm and move the Carriage with the front lifted.

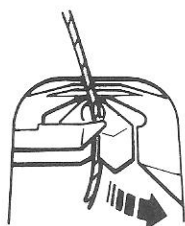

Removing the knitted fabric

— without casting off —

Remove the yarn from Yarn Feeder.
 Cut the yarn and place the end into the Yarn Clip.
 Remove weights from the fabric.
 Set Pattern Dial to "0" and move Carriage across the fabric.

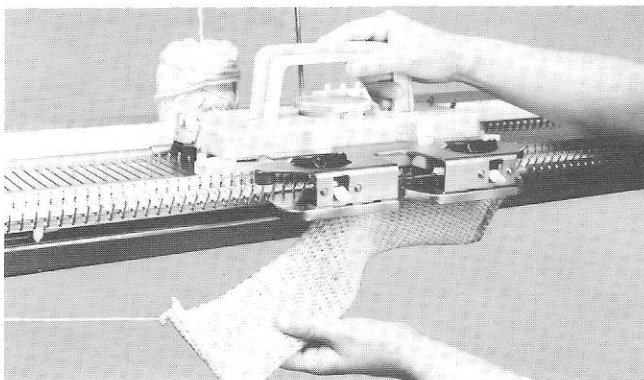

The fabric comes off the needles.

PATTERN KNITTING

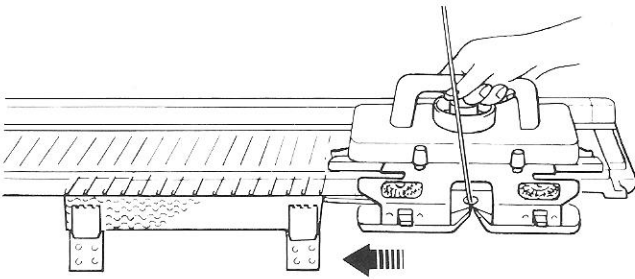

Getting to know about Pattern Knitting

- *Before starting pattern knitting, knit 5 — 6 rows of Plain stitch or waste knitting.
- *Start the Pattern Knitting from right side of the Needle Bed and move the Carriage at an even speed.

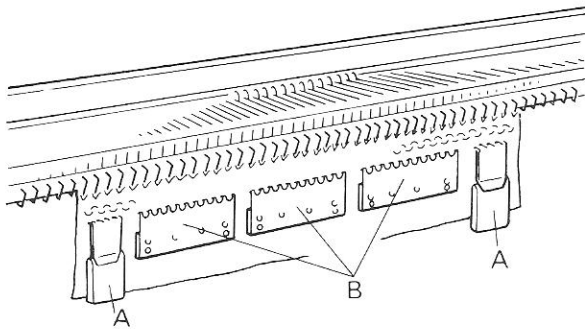

- * Always use Weights.
Hook Claw Weights "A" at both edges of the knitting. Hook Wide Claw Weights "B" evenly across the knitting when you are knitting Slip Stitch or Tuck Stitch and also when using extra thick yarn or textured yarn. (Hook them 3 — 4 rows below the needles and move them up as knitting progresses)

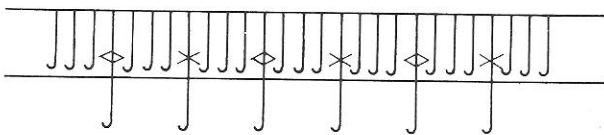

◇ and × are marked alternately on the front edge of the needle bed, and correspond to the Pattern Chart for needle selection.

	①	②	③	④	⑤	⑥	⑦	
6						=		→
5	■	■						→
4	■	■						→
3								←
2	■	■						→
1	◇	×		-	○	-	A	←

Pattern Chart

Follow the Pattern Chart from the bottom line (Order 1).

Each column of the Chart indicates needle selection, Carriage settings, and knitting direction as detailed below.

- Knitting Order
- Needle position
 -needles in B position, or aligned back in B position from D position.
 -needles in D position.
- Russel Lever (left)
- Pattern Dial
- Russel Lever (right)
- Main Yarn Feeder ("A" and "B" stand for different yarns or colours of yarns)
- Knitting Direction.

- * Weaving Knobs must always set to ○ except when Weaving.
- * When you push the needles to D position, hold the fabric against the sinker post by hand.

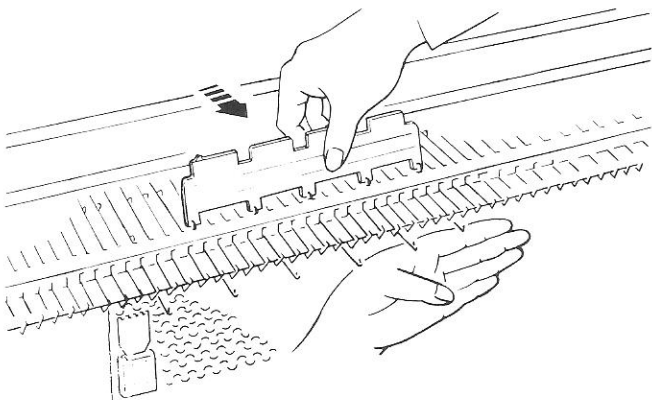

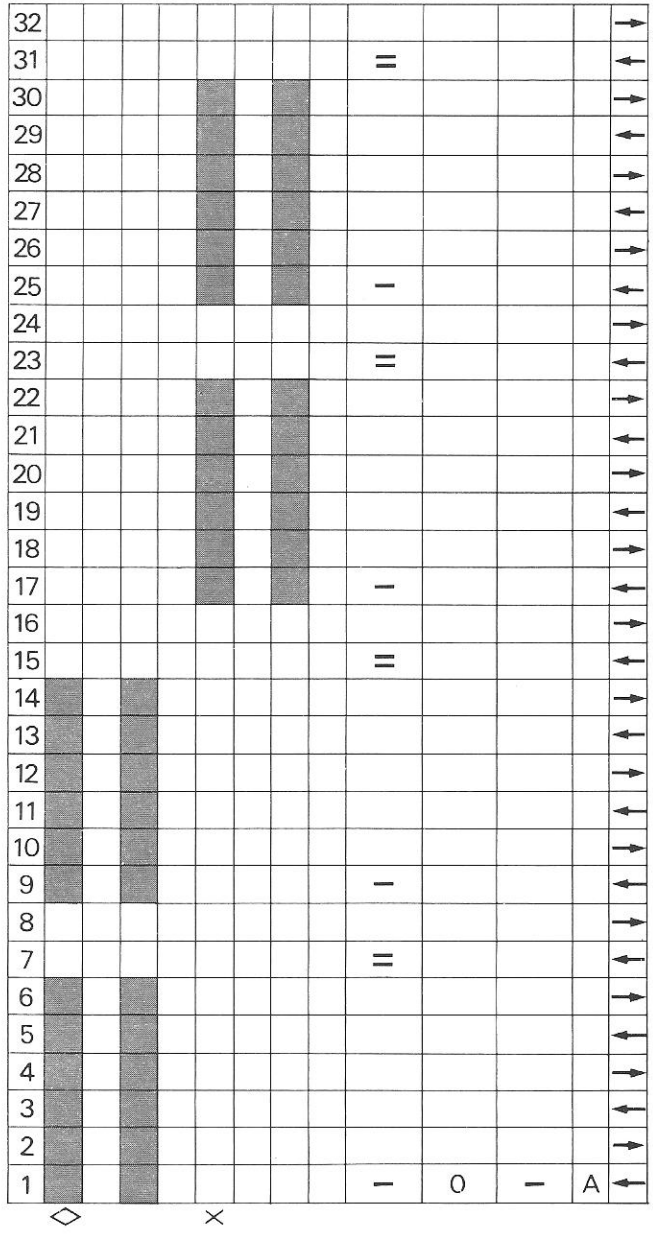
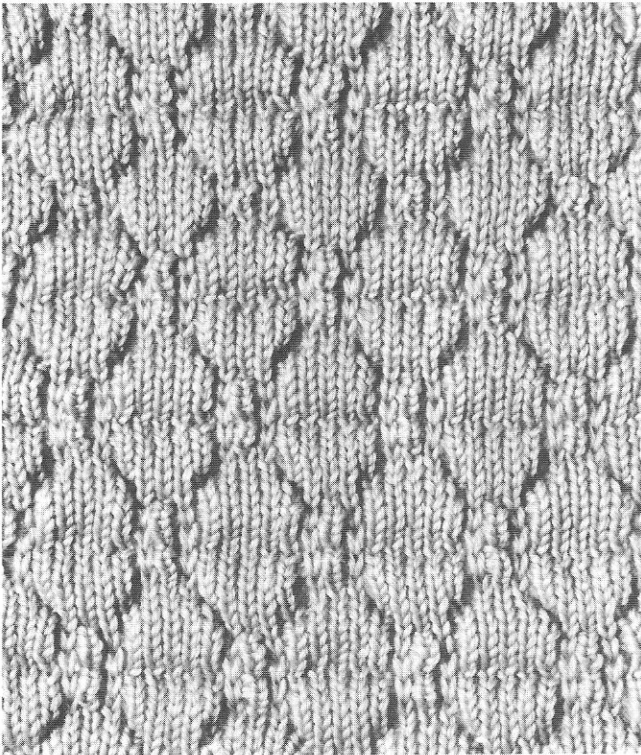
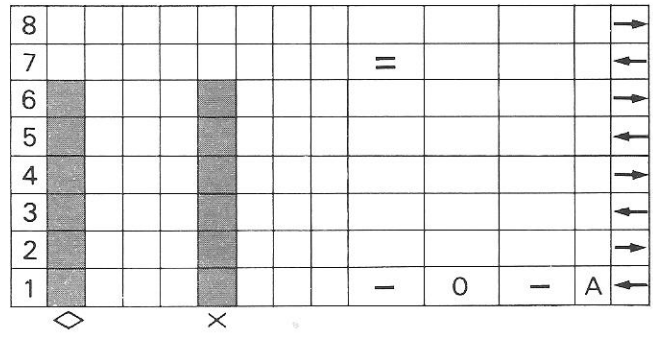
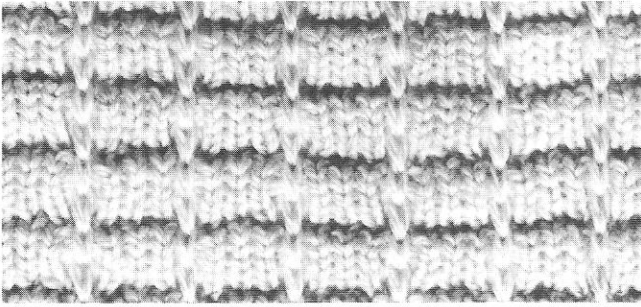
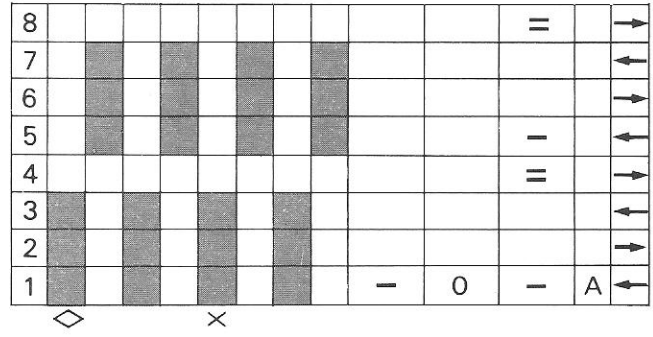
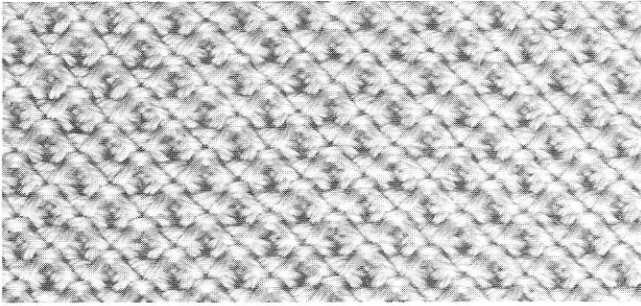

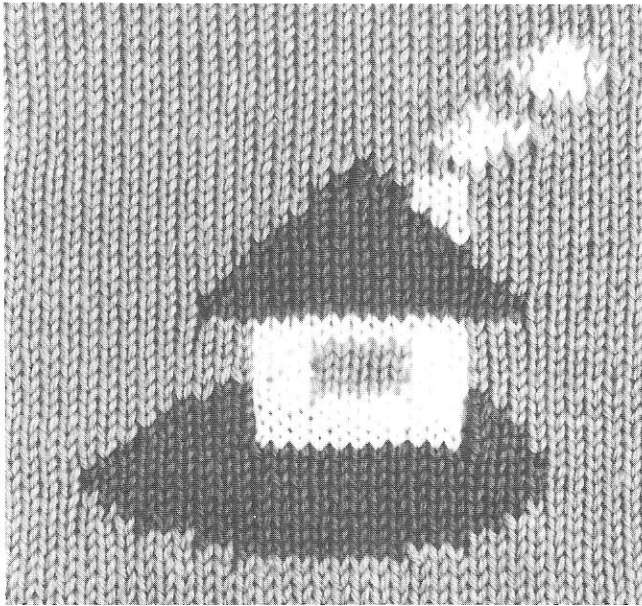

Intarsia Pattern

Intarsia is a method of knitting multi-coloured geometric or pictorial patterns, without floats across the back of the fabric.

If you have the Knit Tracer (optional), you can draw your own intarsia pattern on Pattern Sheet.

* As the wrong side is facing while you knit, draw patterns in reverse.

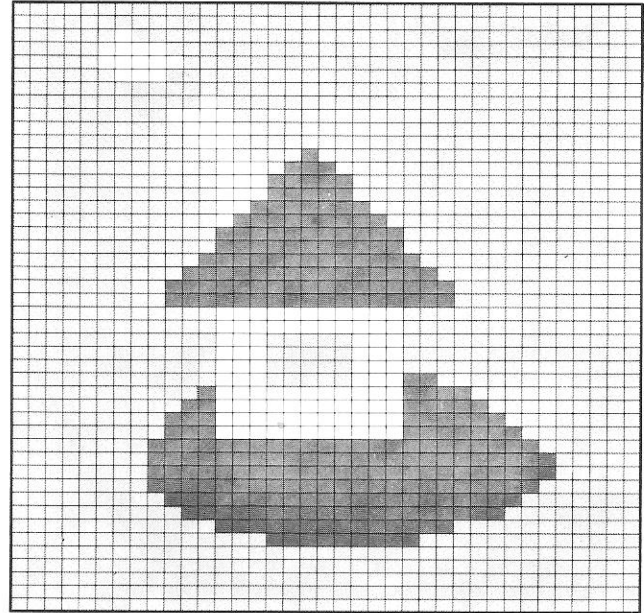

-yarn A (background yarn)
-yarn B (contrast yarn)
-Yarn C (contrast yarn)

For practice, knit following the Pattern Chart above.
Prepare required number of yarn balls in each colour.
3 balls of yarn A, 2 balls of yarn B and C.

- Cast-on 37 stitches and knit 10 rows of waste knitting in Plain stitch ending with the Carriage at the left.
- Hang Wide Claw Weights and Claw Weights on the fabric.

IMPORTANT

Make sure to remove the Tuck Brushes from the Arm before setting the Pattern Dial to "1".

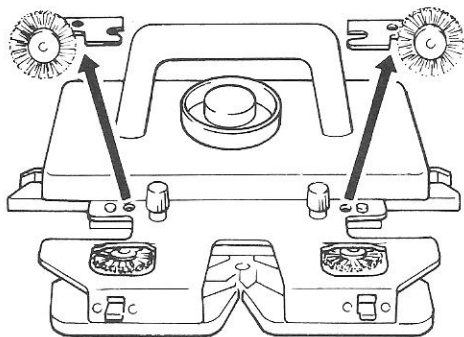
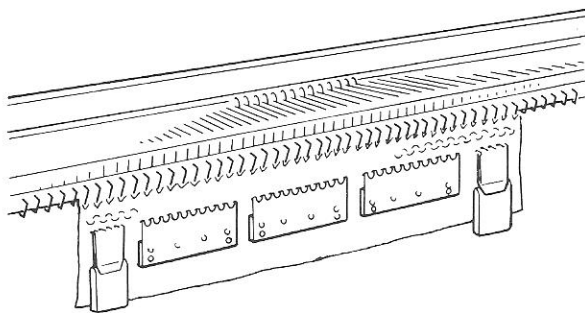

- Knit 5 rows with yarn A.
- Remove the yarn from the Yarn Feeder and Auto Tension, and place the yarn balls on the floor, in front of the machine.

— Set the Pattern Dial to “S” and move the Carriage to the left.

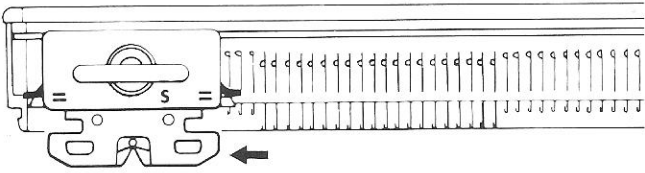

— Set the Pattern Dial to “I” and move the Carriage to the right.
(The needles will be aligned in C position.)

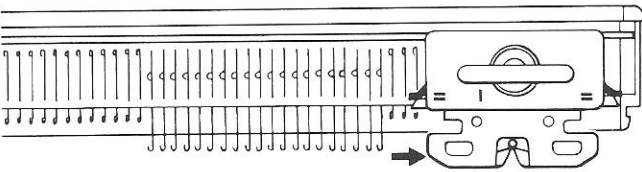

— Set the Stitch Dial 1 number higher than Plain stitch.

— Following the Pattern Chart, lay yarns A and B in the open hooks starting from the Carriage side.

Make sure the latches of all the needles are open before laying yarn.

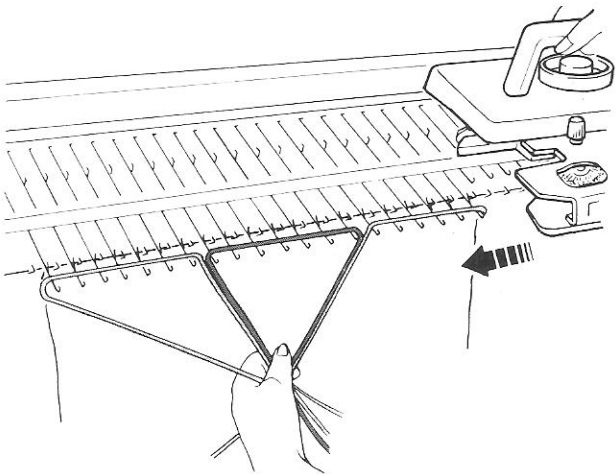
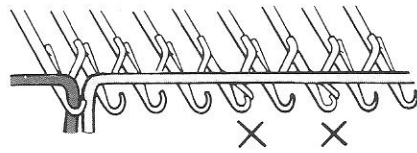
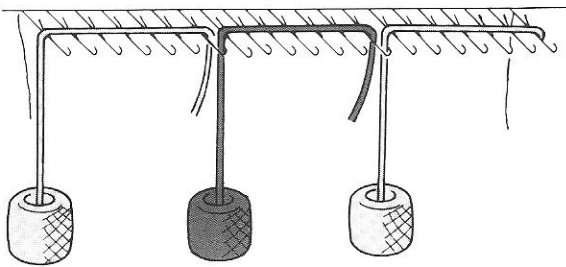

— Holding down the yarns gently to take up slack, move the Carriage slowly across the needles to knit the first row.

The needles knit, and re-align in C position.

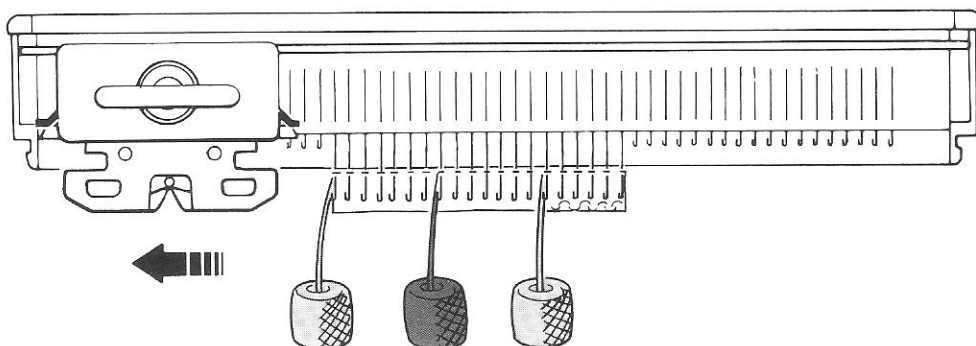

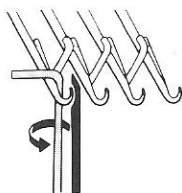
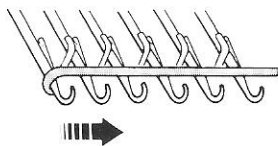

- Lay yarns in the needle hooks starting from Carriage side. To avoid separation of stitches at the edge of each colour yarn, twist yarns as illustrated.

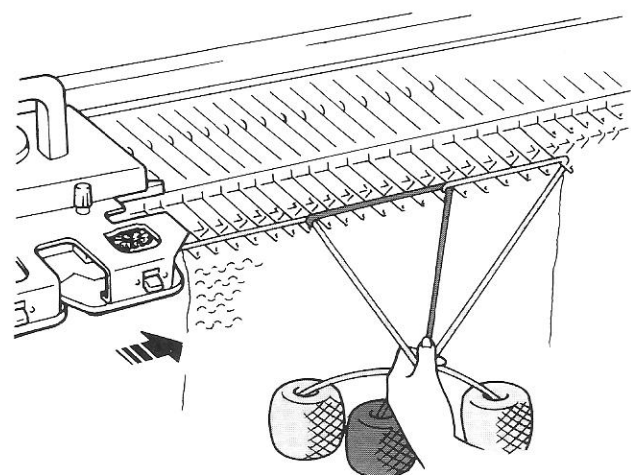
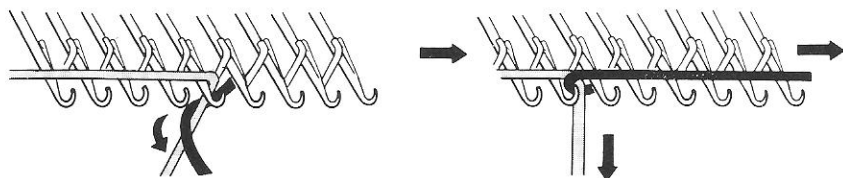

- Holding the yarns gently to take up slack from the yarns, move the Carriage slowly across the needles to knit the second row.

- Following the Pattern Chart, continue knitting by laying the yarns in the needle hooks as for the first and second rows.

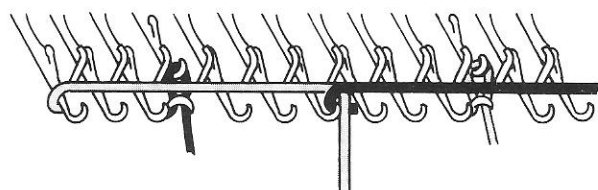
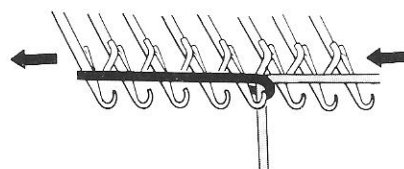

- To knit only 1 or 2 stitches in one colour, lay the yarn on those needles and push them by hand back to B position.
- Continue to knit by laying the yarns in the needle hooks, omitting the needles knitted by hand.

How to knit Plain stitches

- Replace yarn A in the Yarn Feeder and continue to knit, or lay the yarn in hooks of all the needles in C position and move the Carriage to knit a row.

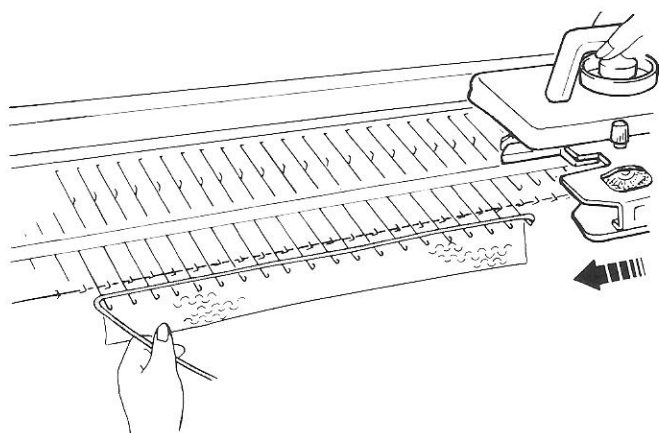

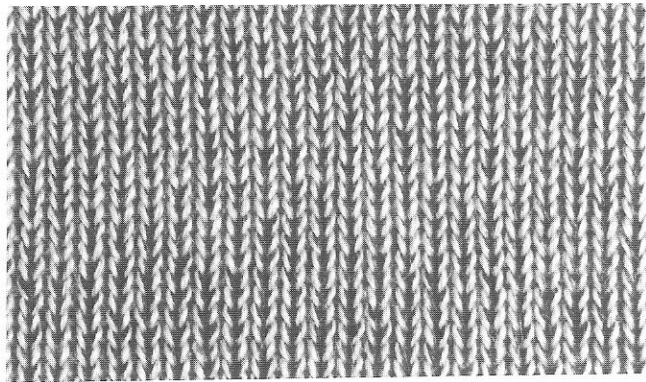

Plating

Two different colour yarns are knitted together. One yarn appears on the plain side while the second yarn appears on the purl side of the fabric.

Since two yarns are knitted together, use thinner yarns than for other patterns, and Stitch Dial must be set at the number which totals the stitch dial number for each type of yarn used. (e.g. if two tension 3 type yarns are used, knit at Stitch Dial 6)

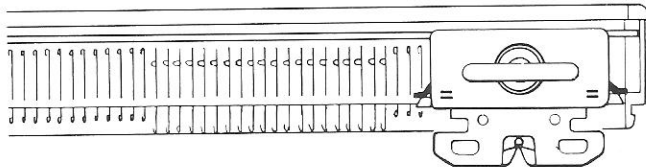

- Cast-on with waste yarn.
- Set the Carriage for the Plain stitch.
 Pattern Dial.....0
 Russel Levers.....=

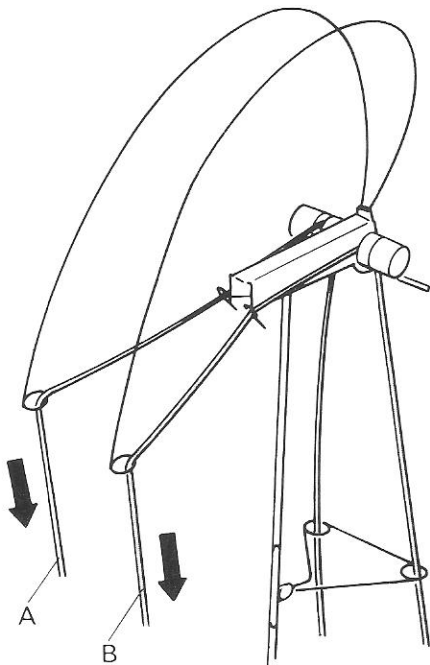

- Thread the main yarn "A" into the left side Auto Tension and the plating yarn "B" into the right one.

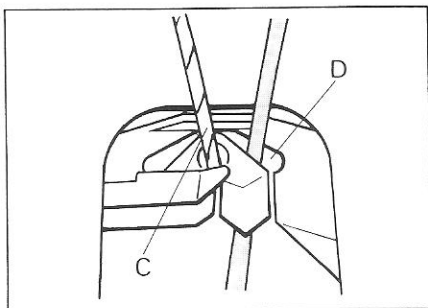

- Set the main yarn into the Main Yarn Feeder C and plating yarn into the Plating Yarn Feeder D.

- Knit in the same manner as done for Plain stitch.

Main yarn appears on plain side and plating yarn appears on purl side.

Make sure that main yarn A is threaded through left side of Auto Tension.

TAKING A TENSION GAUGE

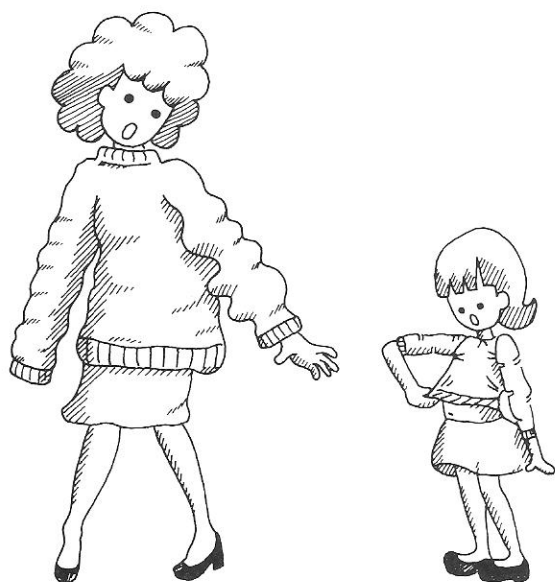

Tension Gauge

Tension Gauge indicates how many stitches you need to cast-on, and how many rows you need to knit to make a 10cm. square. It is very important to take a correct tension gauge to ensure tht your garment is the correct size.

Tension Swatch

To take a correct tension gauge, the tension swatch must be knitted in the same stitch pattern, with the same yarn and Stitch Dial as to be used for the garment.

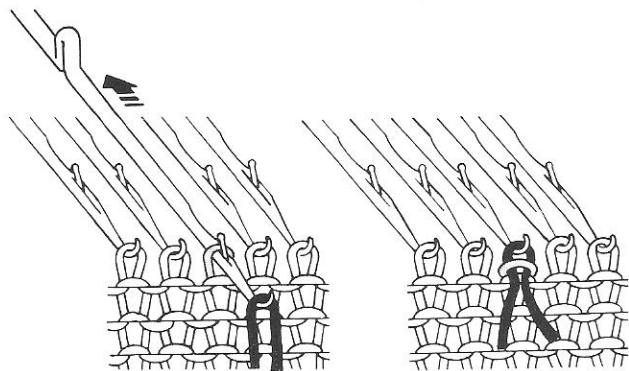
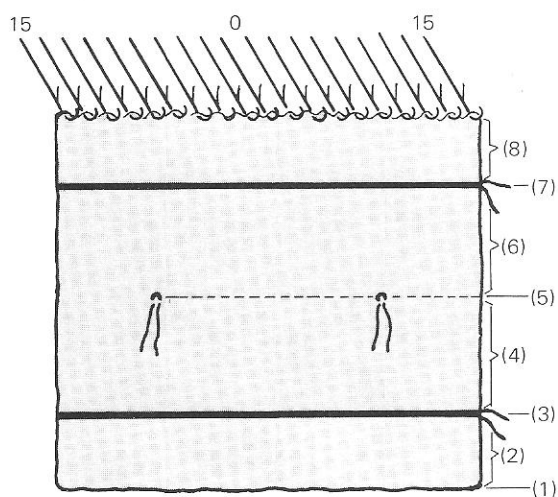
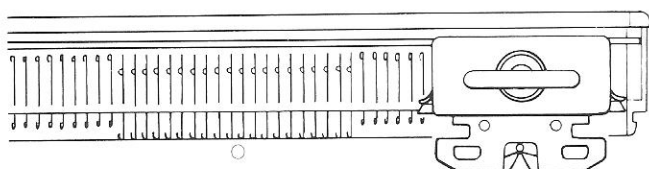

To knit a Tension Swatch:—

Prepare the yarn you selected and a small amount of contrasting colour yarn for marking the swatch.

Decide on the Stitch Dial number referring to page 10. It is recommended that you try different stitch dial settings till you obtain a suitable tension for the yarn and stitch pattern chosen.

Knit the swatch as instructed below.

- (1) Push 15 needles on both sides of the centre(0), to B position (30 needles altogether).
- (2) Cast-on with main yarn and knit 10 rows in selected stitch pattern, with Stitch Dial on setting chosen.
- (3) Change to the contrast yarn, and knit two rows in Plain stitch.
- (4) Remove contrast yarn and rethread the main yarn. Knit 15 rows in selected stitch pattern with correct stitch dial setting.
- (5) Push the 11th needle on both sides of the centre(0) to D position and place a piece of contrast yarn in each of the needle hooks.
Push the needles back to B position.
- (6) Knit another 15 rows.
- (7) Thread the contrast yarn and knit 2 rows in Plain.
- (8) With main yarn, knit 10 rows in selected stitch pattern with correct stitch dial setting.

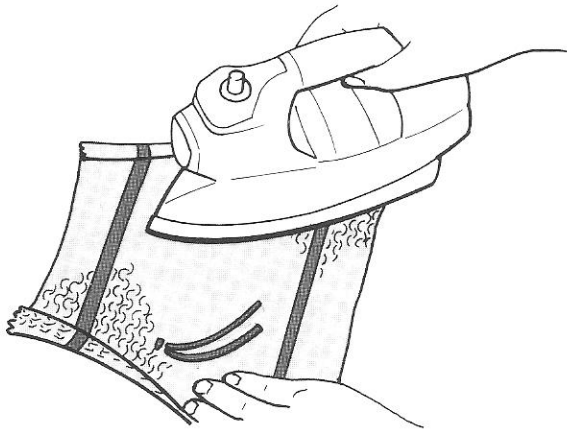

Remove the yarn from the Yarn Feeder.
 Set the Pattern Dial to Plain stitch.(0)
 Remove the swatch from the machine.

MAKE A NOTE OF THE STITCH DIAL NUMBER

Allow the swatch to rest for several hours, to return to its natural condition, after being stretched on the machine.

Press according to yarn manufacturers instructions.
 Allow to dry before taking tension gauge.

In case of every other needle selection

When you knit a garment using every other needle, count the number of needles for knitting a tension swatch by omitting the non-knitting needles, and also put yarn marks at the position marked by arrows as shown below.

Needle arrangement

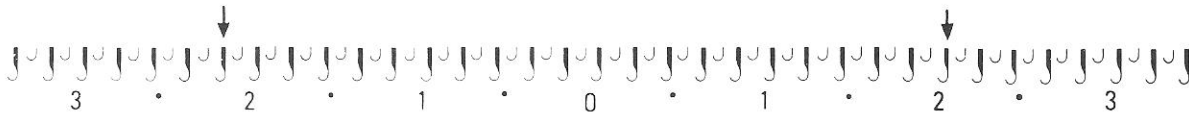

Yarn mark

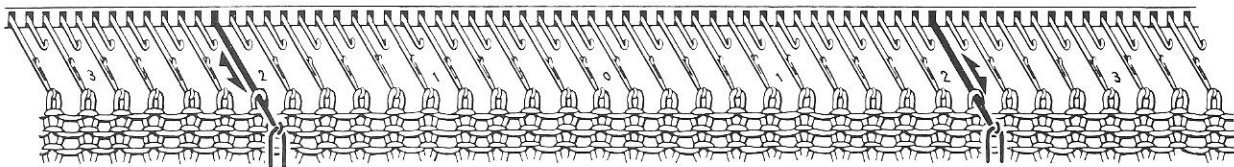

Gauge Scale

This scale is designed to count the number of stitches and rows required to knit 10cms., measuring between contrast yarn marks on the tension swatch.

The scale has two sides. The side "S" is used for measuring stitches and the side "R" is for rows.

Following the instructions overleaf, measure the tension swatch to obtain the correct tension gauge.

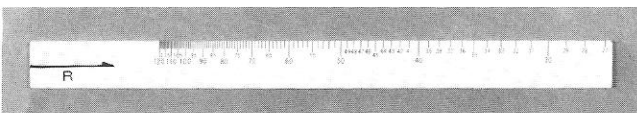
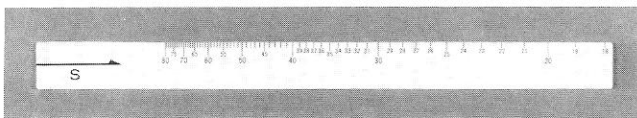

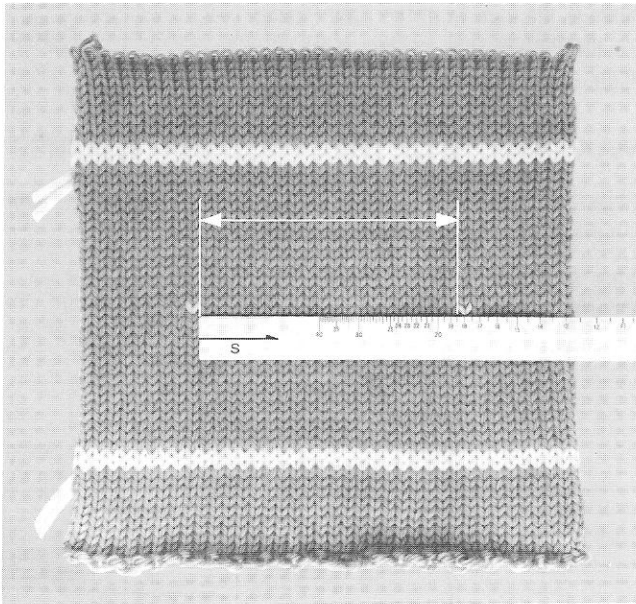

How to measure the tension swatch

Stitches (Horizontal)

Use the Gauge Scale (blue) with "S" side up. Place the arrow end of the gauge scale inside the left stitch in contrast yarn. Measure to the inside of the right hand contrast stitch.

The number of this point indicates how many stitches are required to knit 10cms. The Scale should be used from the edge indicated by the arrow, i.e. from the left edge.

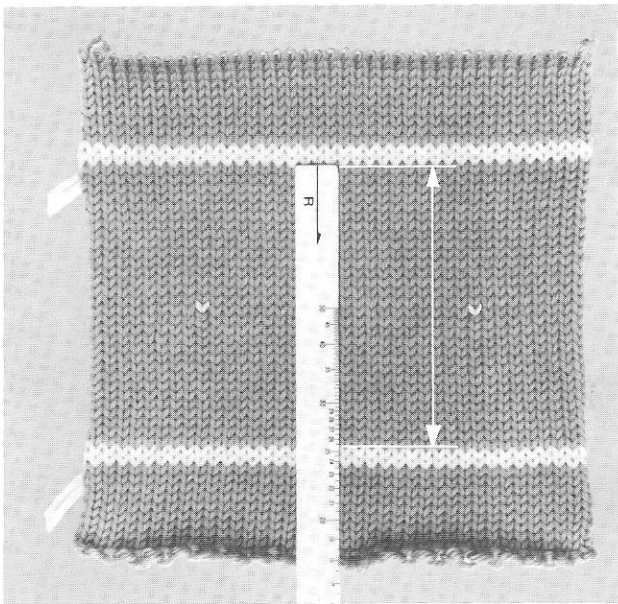

Rows (Vertical)

Use the Gauge Scale (blue) with the "R" side up. Place the arrow end of the gauge scale at the top of the tension swatch, just below the rows knitted in contrast yarn. Measure to the inside of the two rows knitted in contrast yarn at the bottom of the tension swatch.

The number at this point indicates how many rows are required to knit 10cms.

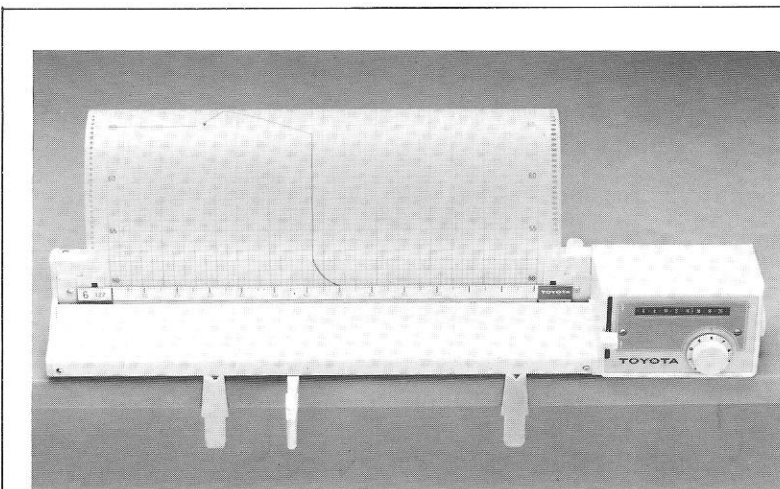

KNIT TRACER (OPTION)

Trace the pattern on the sheet and slip it into the machine. Very simple and easy to use. It's all done automatically for you.

HOW TO USE THE KNIT TRACER (OPTION)

The instruction book of Knit Tracer is based on 4.5mm pitch machines.

Please refer to the instruction book of Knit Tracer and replace "Measuring Tension Swatch", "Setting Rows and Stitches", and "Drawing a pattern on the sheet" with following explanations for your 9.0mm pitch bulky knitter.

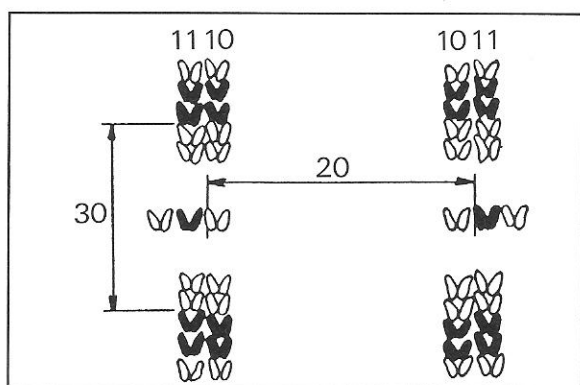

Measuring Tension Swatch

Knit the swatch as instructed on page 37 and 38 of this book.

Horizontal

Place a ruler (not Gauge Scale) on tension swatch and measure the distance between the two marked stitches (a width of 20 stitches).

Vertical

Place a ruler on tension swatch and measure the distance between the two parts of contrast yarn, 30 rows.

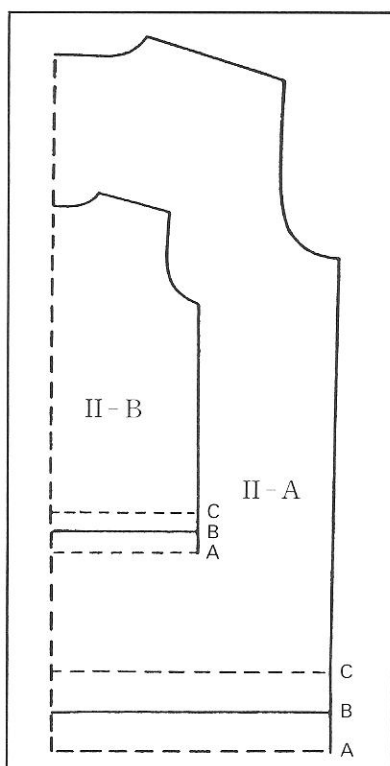

Setting Rows and Stitches

Set the number you measured on tension swatch to the Knit Tracer.

For example:

30 rows measure 13.6cm.

20 stitches measure 14.3cm.

Set wor indicator to 13.6.

Set stitch scale No. 11.

Drawing pattern on the sheet

Draw the pattern in HALF size on your Knit Tracer sheet.

All measurements must be reduced to HALF size.

Sunset Bay Partners & Assoc, Inc / The Knitting Closet

HOW TO KNIT A GARMENT —Lady's pullover—

The instruction below explains how to knit a garment without using the Knit Tracer.
A pullover is taken as an example based on the size and the tension gauge as shown below.

Measurements of finished garment

Bust.....96cm.
Length.....59cm.
Back Width.....37cm.
Sleeve Length.....56cm.

Material: Extra thick yarn.....500gs.

Tension Gauge: 16 stitches by 22 rows to 10cm. sq. measured over Plain stitch with the Stitch Dial at 5.

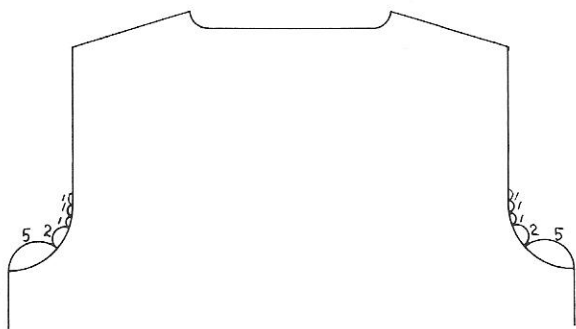
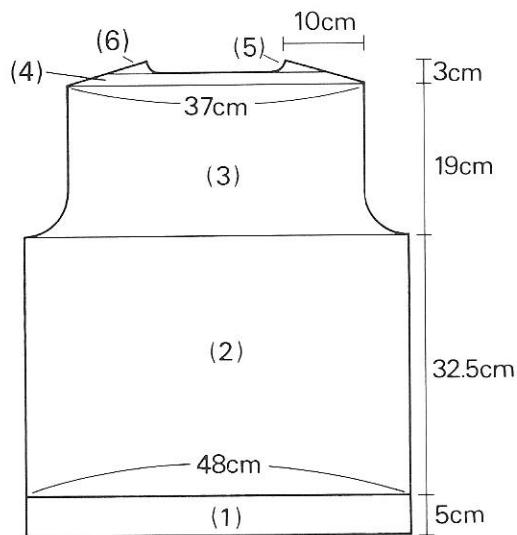

Back

(1) welt

— Arrange 80 needles and knit welt by 1 × 1 rib.

(1 × 1 Rib. — page 49: on step 3, knit 4 rows starting from the right side, and on step 6, set the Row Counter to 000, turn the Feeding Lever and knit 12 rows.)

(2) straight up to the armhole

— Stitch Dial 5, knit 72 rows without shaping. (Row Counter at 084) Carriage at the right side.

(3) shape armhole

— Decrease 5 stitches at the beginning of next 2 rows and 2 stitches of next 2 rows.

(Decreasing multiple stitches — page 18)

— Decrease 1 stitch at both ends of next and following alternate rows, 3 times in all till the Row Counter shows 094.

(Decreasing 1 stitch — page 18)

— Knit 32 rows without shaping. (Row Counter at 126) Carriage at right side.

(4) shape shoulders by partial knitting

— Set the Russel Levers to —, push up 4 needles on the left side to D position and knit 1 row.

— Push up 4 needles on the other side to D position and knit 1 row.

(Partial knitting by decreasing stitches — page 47)

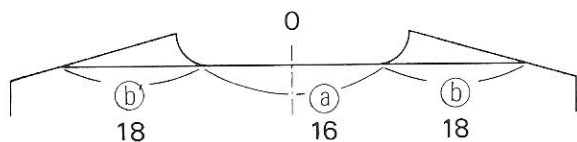

(5) shape neck edge and first shoulder

At the neck line, divide into three sections, right (b), centre straight (a), and left (b), and work each section separately to shape the neck edge and shoulder at the same time, as instructed below.

- Hold 34 needles on section (a) and (b).
(*Holding stitches on D position — page 54*)
- Knit 1 row and Decrease 3 stitches at the neck edge.
(*Decreasing multiple stitches — page 18*)
- Decrease 4 stitches on the shoulder side by partial knitting.
(*Partial knitting by decreasing stitches — page 47*)
- Knit 1 row and decrease 2 stitches at neck side.
- Decrease 4 stitches by partial knitting.
- Knit 1 row. (The Carriage at left side and Row Counter at 133.)
- Break the yarn leaving the end 10cm. and unthread the yarn.
- Push back the needles for the right shoulder to C position.
- With waste yarn, knit several rows and remove the section from the machine.
- Push back the empty needles to A position.
- Push 16 needles on section (a) back to C position.
- Put a yarn mark at the centre(0) of the Needle Bed.
(*Put yarn mark — page 56*)
- Remove the section on waste knitting and push back the empty needles to A position.

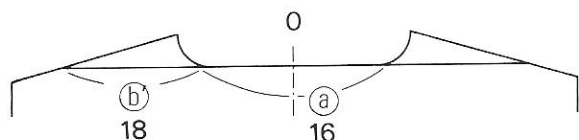
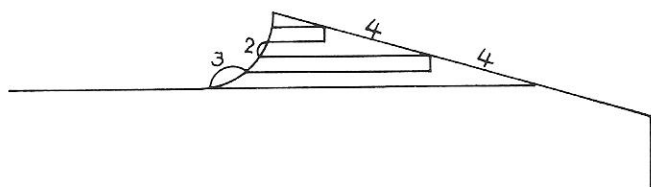

(6) shape neck edge and left shoulder

- Push back the needles of section (b) to C position.
- Have the Carriage on the left side of the fabric, and work section (b) as done for the section (b) but in a reverse shaping.
- Break the yarn leaving the end three times the width of the shoulder, and unthread the yarn.

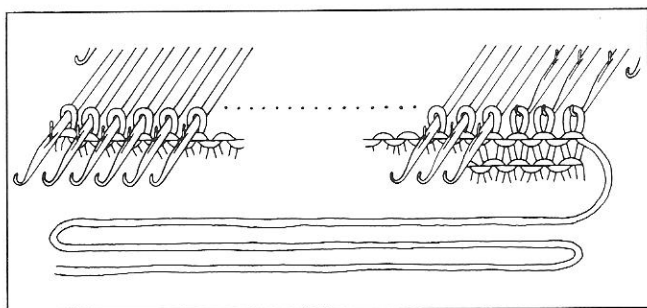

Front

(1) — (2) knit up to the armhole

- Knit in the same manner up to the neckline as done for the back till the Row Counter shows 084.

(3) shape armhole

- Shape armhole in the same way as for back till Row Counter shows 094.
- Knit 24 rows without shaping.
Carriage at the right side, Row Counter at 118.

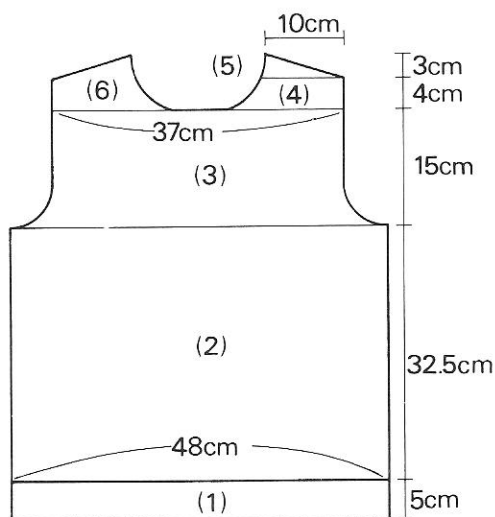

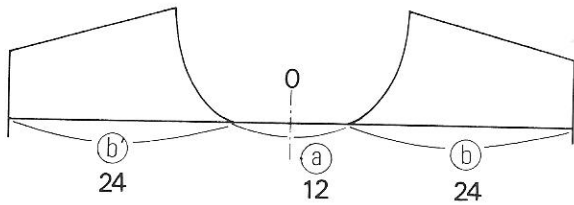

(4) shape front neck edge of right section

- Set the Russel Levers to —
- Hold 36 stitches on section (a) and (b).

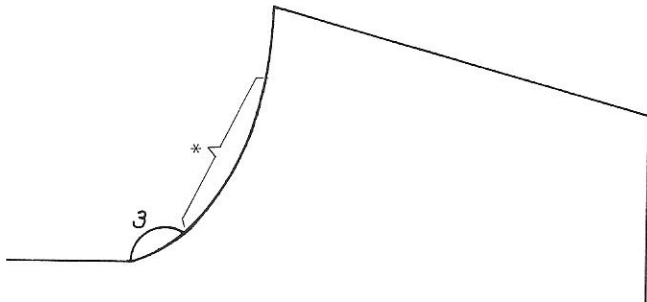

- Knit 1 row and decrease 3 stitches at the neck edge and knit 1 row.
- Decrease 1 stitch at the beginning of the next and every following alternate rows, 4 times in all (*).
(Row Counter at 126)

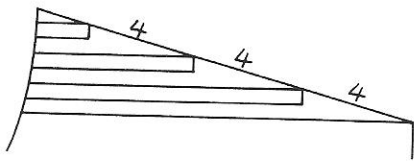

(5) shape right shoulder

- Work partial knitting by decreasing stitches in the same way as for back.
- Push back the needles for the right shoulder to C position.
- Remove the section on waste knitting.
- Break the yarn leaving the end three times the width of the shoulder and unthread the yarn.

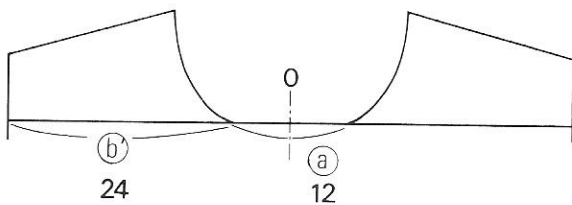

(6) shape neck edge and left shoulder

- Push back 12 needles on section (a) to C position.
- Put a yarn mark at the centre(0) and remove the section on waste knitting.
- Work section (b) in the same way as for the section (b) but in a reverse shaping.
- Break the yarn leaving the end 10cm.

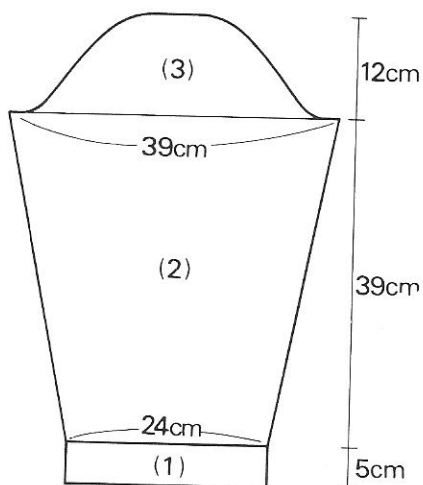

Sleeves (both alike)

(1) knit cuff

- Arrange 40 needles and knit in the same way as for the welt.

(2) shape underarm

- Stitch Dial 5, increase 1 stitch at both ends of the next and every following 6th row, 5 times and 7th row 7 times in all until the Row Counter shows 097.
64 stitches remain on the Knitter.

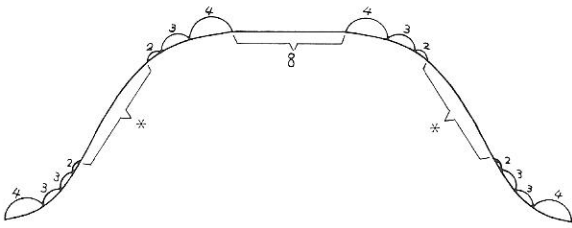

(3) shape sleeve top

- Decrease 4 stitches at the beginning of the next 2 rows, 3 stitches at the beginning of the next 4 rows, and 2 stitches at the beginning of the next 2 rows.
- Decrease 1 stitch at both ends on the next row and every following alternate row, 7 times in all (*).
- Decrease 2 stitches at the beginning of the next 2 rows.
- Decrease 3 stitches at the beginning of the next 2 rows.
- Decrease 4 stitches at the beginning of the next 2 rows. (Row Counter at 125)
- Put a yarn mark at the centre(0) and cast off the remaining 8 stitches by using back stitch method.

(Joining on the machine, step 6 — page 60)

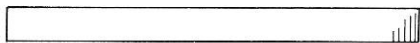

Neckband

- Arrange 68 needles for 1 × 1 . Rib and knit 7 rows as done for the welt.
- Remove the neckband on waste knitting.
- Break the yarn leaving the end three times the width of the neckband and unthread the yarn.

Blocking and pressing

After knitting the pieces of your garment, you must lay them flat and pin them out to their correct shape and size.

- Pin out a piece with its wrong side facing up on an ironing board at the widest point, afterwards pinning it to its correct length.
- Pin all around the edges, spacing the pins about 2—3cm. apart. (Place the pins inside the ribbed edge.)
- Press them lightly with a steam iron or over a damp cloth.
- Leave the pieces to dry before removing the pins.

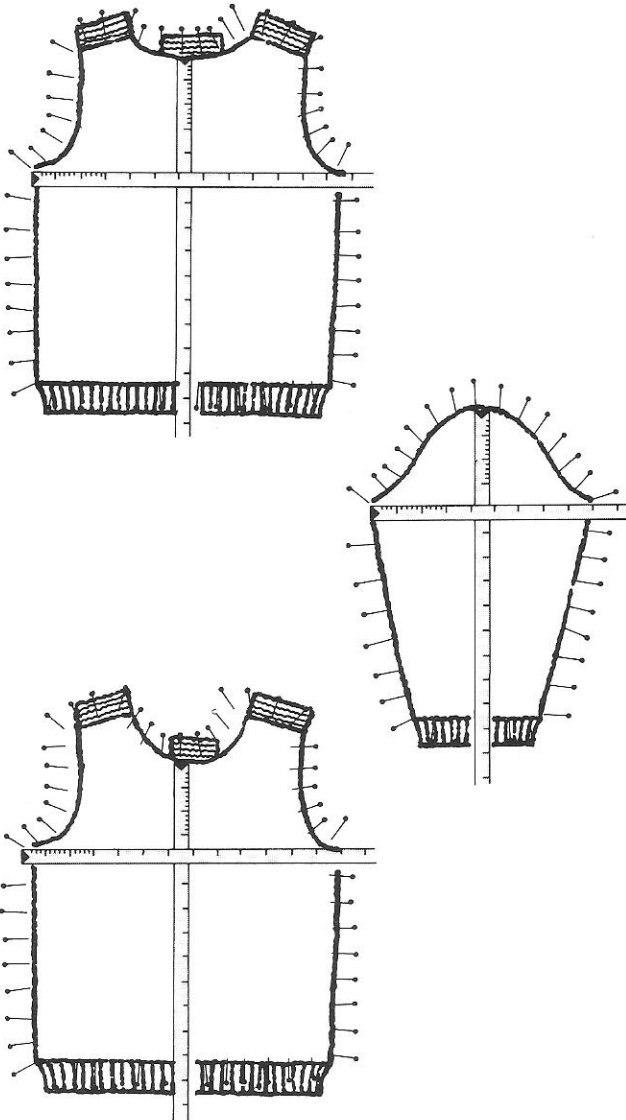

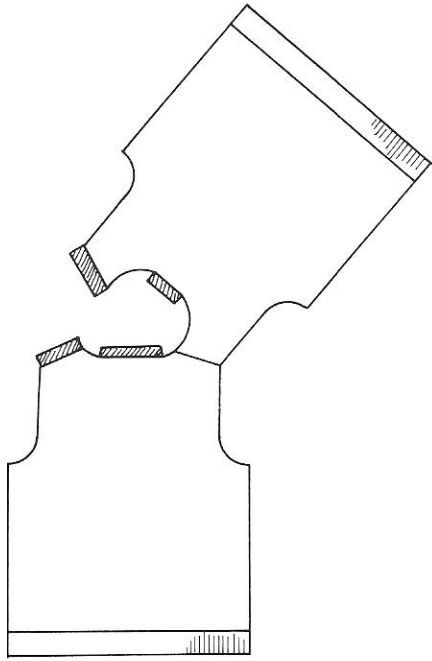

Making up

- Join the right shoulder on the machine using the yarn end.
Joining on the machine, stitch to stitch — page 59.
Replace the back shoulder on the needles first.

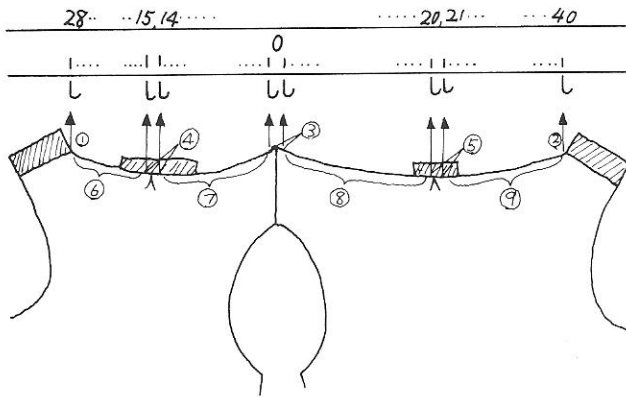

- Join the neck edge and neckband on the machine.
Joining on the machine, open stitches to side edge — page 61.
 - Arrange 40 needles on right side of centre (0) for the front neck edge and 28 needles on left side for the back.
 - With right side facing, hang neck edge in the order as illustrated.
 - With wrong side facing you, hang the neckband.

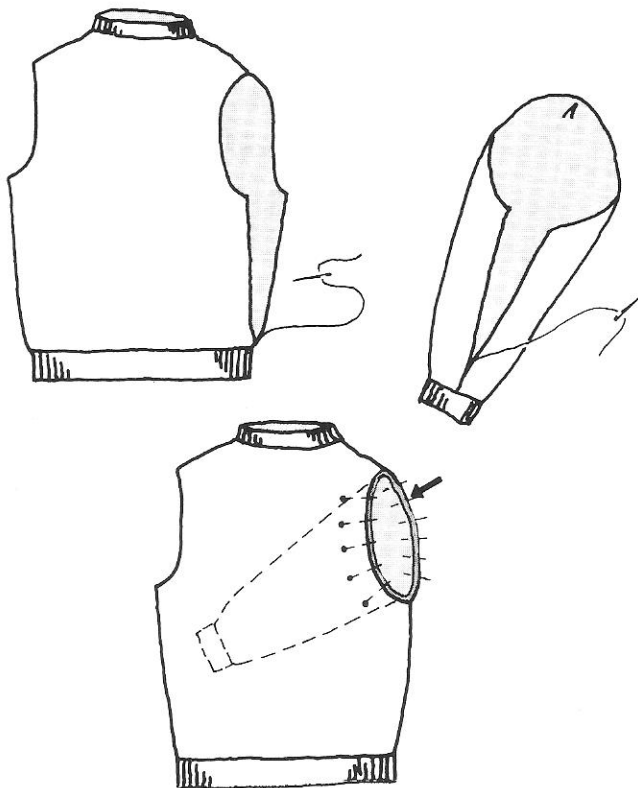

- Pick up and finish off the left shoulder to correspond with the right shoulder.
- Join the side, neckband and sleeve seams.
(Blind stitch — page 62)
- Turn the garment to the wrong side and slip the sleeves into the armhole, with the right side facing each other. Pin them as illustrated and work slip stitch along the edges.
- Sew in yarn ends on the wrong side.
(sew in yarn end — page 63)
- Give final press.

KNITTING TECHNIQUES

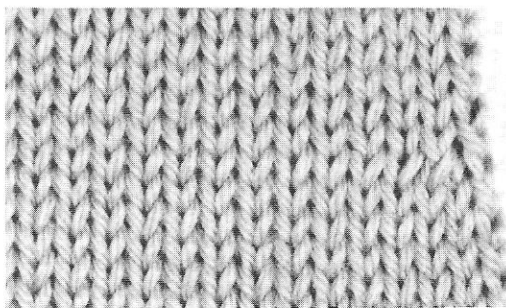
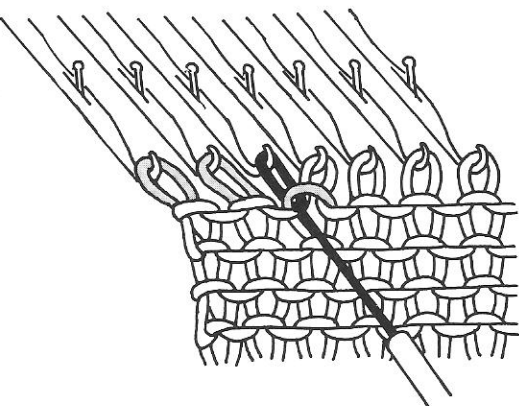
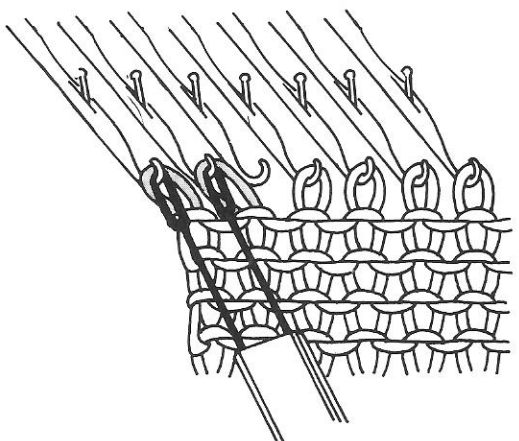
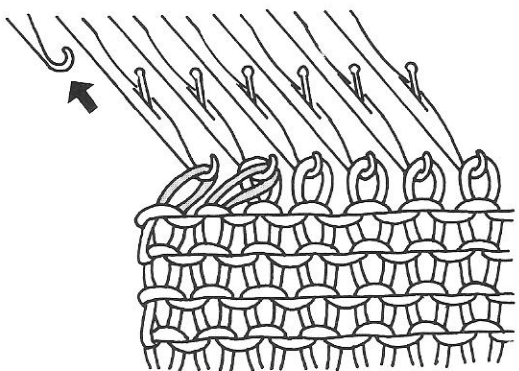
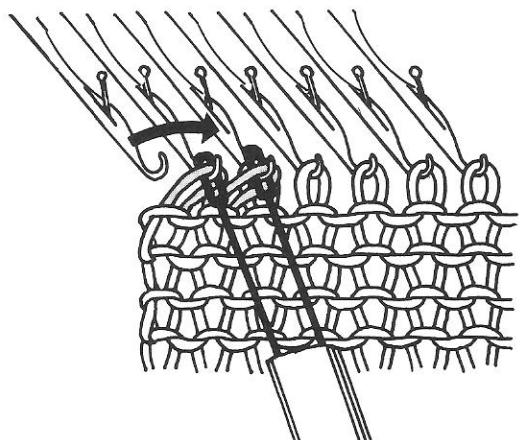

Fully fashioned decrease

It is possible to decrease 1 stitch at both ends of the row at the same time.

1. Using a two prong Transfer Tool, transfer the two end stitches one needle in.
(When using alternate needles, use a three prong Transfer Tool.)
2. Push the empty needle back to A position.
Continue to knit.

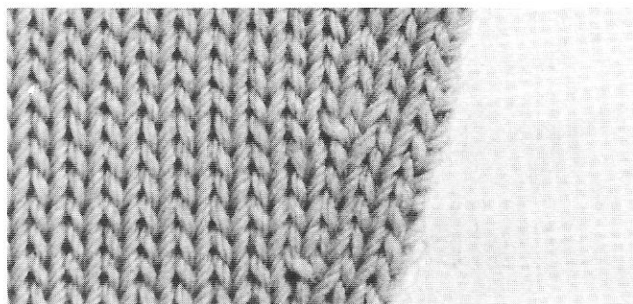

Fully fashioned increase

It is possible to increase 1 stitch at both edges of the row at the same time.

1. Push the adjacent empty needle to B position.
Using a two prong Transfer Tool, transfer the two end stitches one needle out.
(When using alternate needles, use a three prong Transfer Tool.)
2. Pick up the loop below the third stitch and place it onto the empty needle as shown.
Continue to knit.

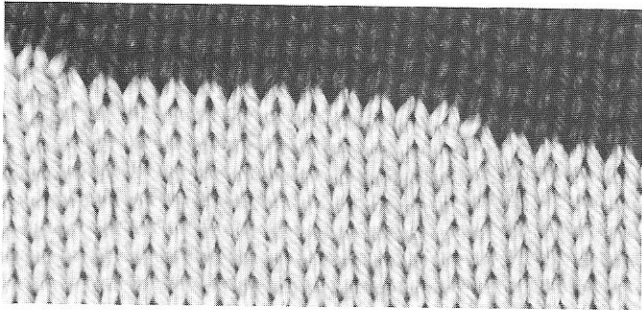

PARTIAL KNITTING is used to shape a gentle slope, such as shoulders, darts, etc.

You can do partial knitting only at the opposite end to the Carriage. If you wish to shape both sides, work left and right alternately.

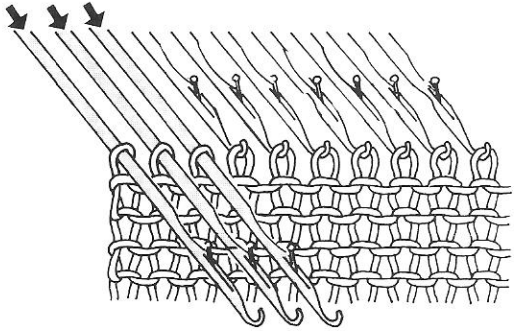

Partial knitting by decreasing stitches

Set the Russel Levers to —.

1. Push the needles to be decreased, to D position at the opposite to the Carriage.

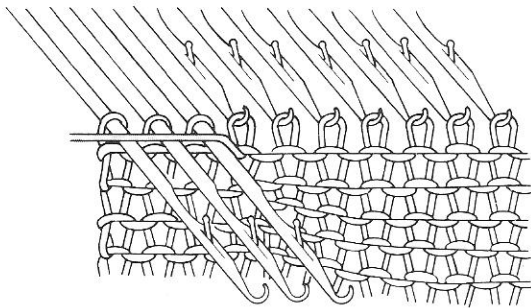

2. Knit 1 row.

The needles in B position knit.

The needles in D position remain inactive and the yarn passes over them.

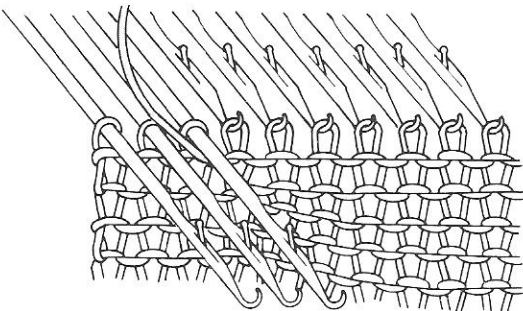

3. To prevent a hole from being formed in the fabric, pass the yarn under the first inside needle in D position and over the remaining needles. (If partial knitting is required at both sides, repeat step 1 before knitting the next row.)

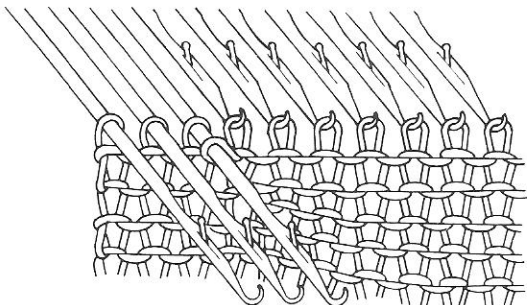

4. Knit 1 row.

This completes the first operation of partial knitting. (If partial knitting is required at both sides, apply step 3.)

Repeat steps 1 — 4.

After completing partial knitting, push the needles in D position back to C position and continue to knit.

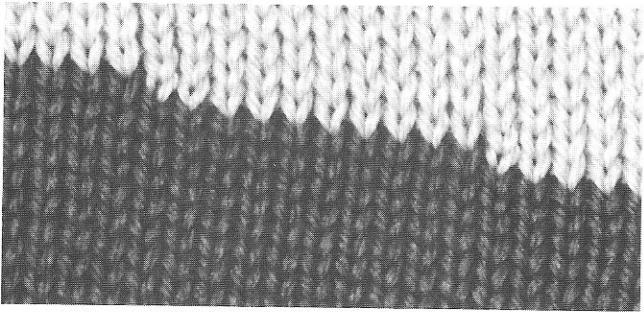

Partial knitting by increasing stitches

Set the Russel Levers to —.

1. Push all working needles to D position.
2. On the Carriage side, push the needles to be increased back to C position.

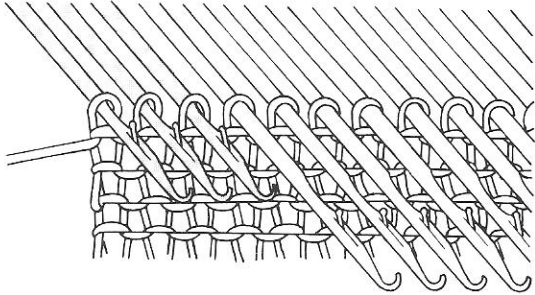

3. Knit 1 row.

The needles in C position knit the yarn. The needles in D position remain inactive and the yarn passes over them.

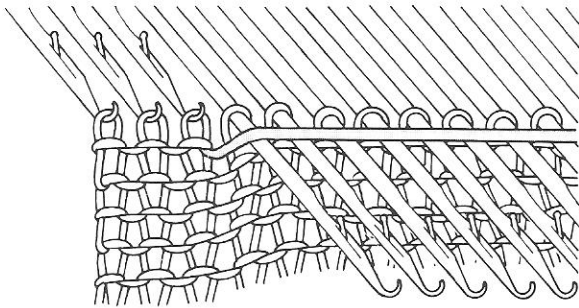

4. To prevent a hole forming, pass the yarn under the first inside needle in D position and over the remaining needles. If partial knitting is required at both sides, repeat step 1 before knitting next row.

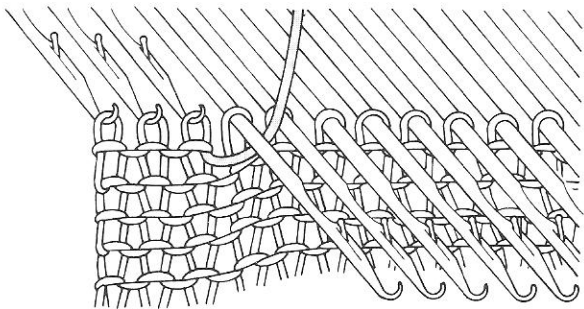

5. Knit 1 row.

Repeat steps 2 — 5.

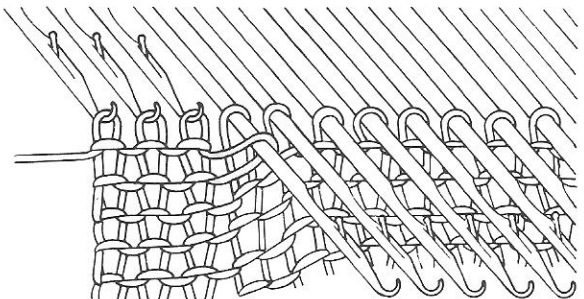

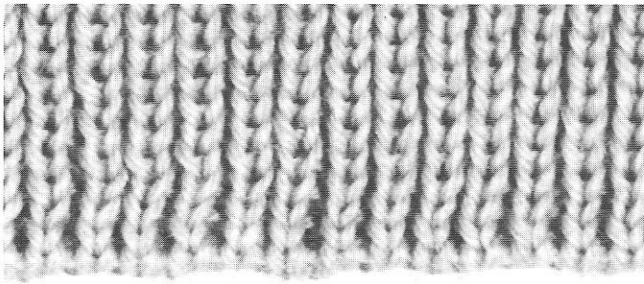

1 × 1 Rib

If you don't have a Ribber, this method of knitting ribs can be used for knitting cuffs, neckbands and welts.

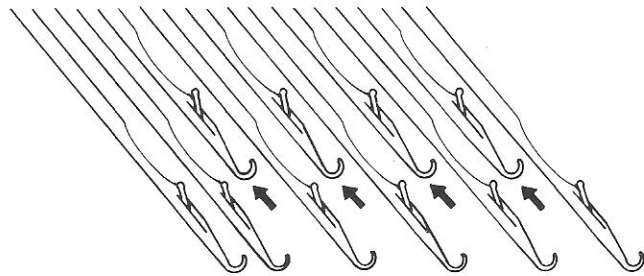

1. Push the required number of needles to B position. Push back every alternate needle to A position, starting with the third needle from the left side.

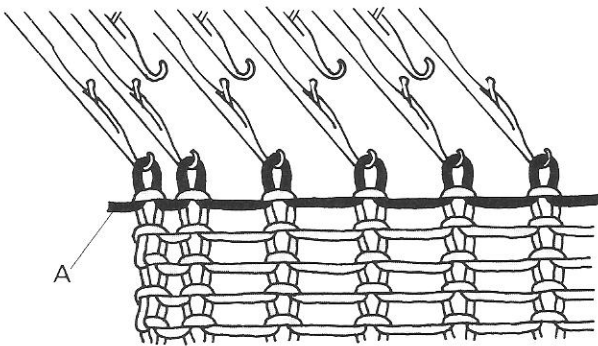

2. Cast-on and knit several rows of waste yarn.
Hang Claw Weights at both edges of knitting.
Knit 1 row with Ravel Cord "A".

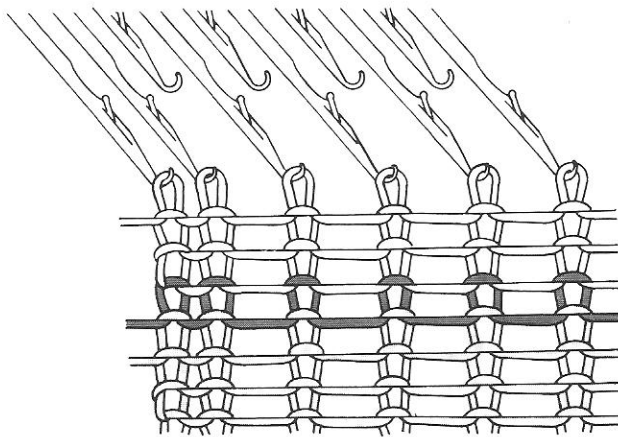

3. Thread the main yarn and knit 4 rows with Stitch Dial at 0.

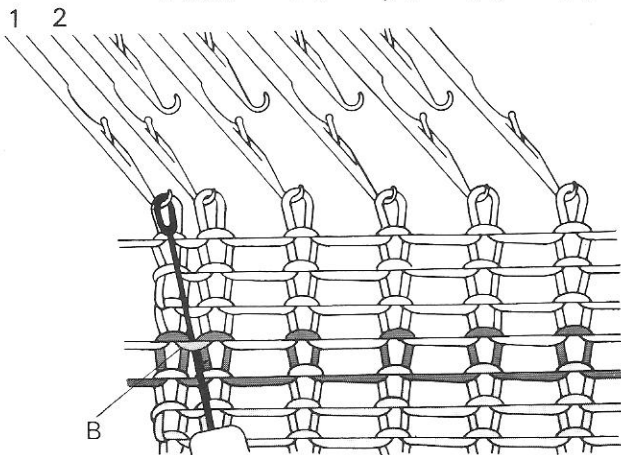

4. Insert the Transfer Tool into the left end sinker loop "B" on the first row of the main knitting (above the Ravel Cord).
(Between needles 1 and 2)

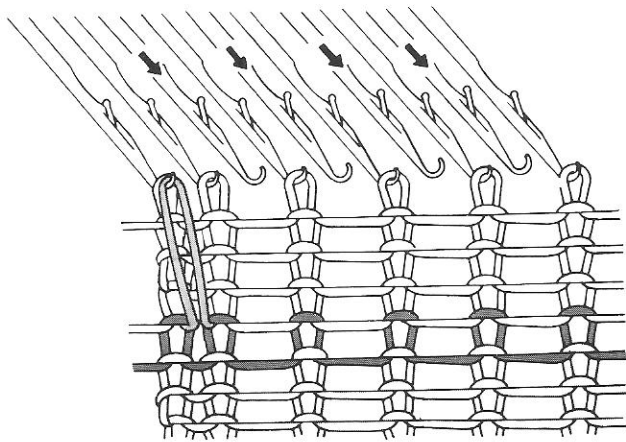

5. Place the loop onto the end needle.
Push the needles that were in A position in step 1, to B position.

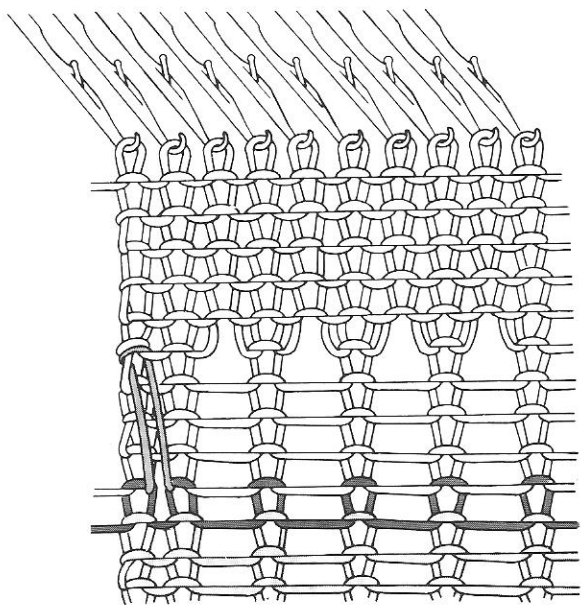

6. Knit the length required for ribbing with the Stitch Dial 2 numbers lower than for Plain stitch.

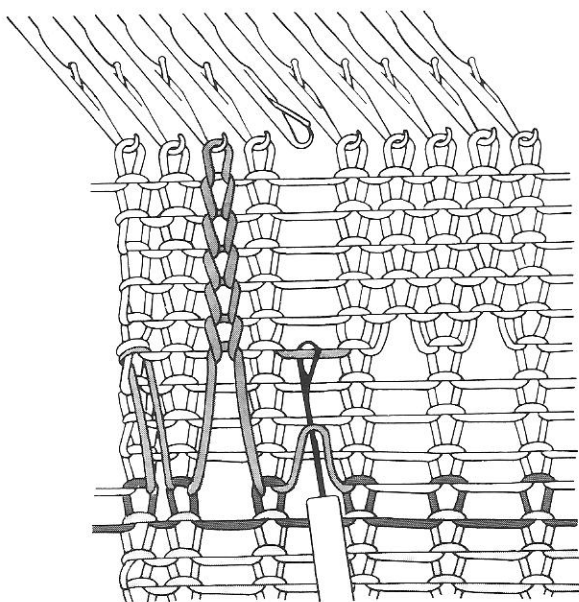

7. Insert the Tappet Tool into the loop of the first row of main knitting and unravel the stitches as shown.
Skip over the next 3 rows and catch the yarn on 5th row crossing above, in the hook of the Tappet Tool.

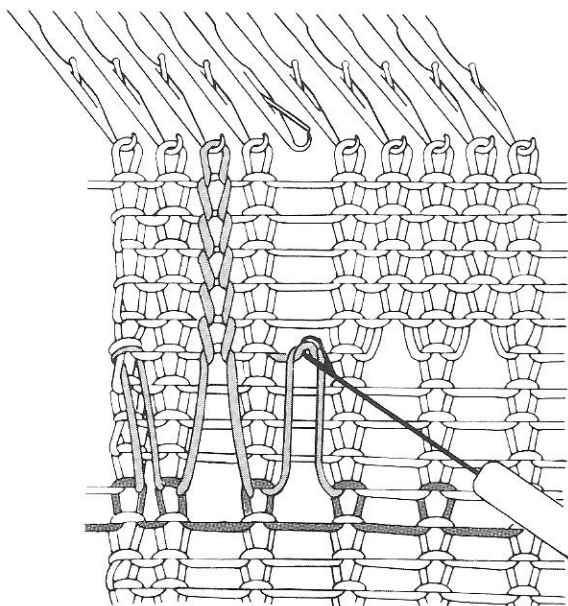

8. Pull the Tappet Tool towards you.
The first stitch will slip off the Tappet Tool, forming a new stitch.

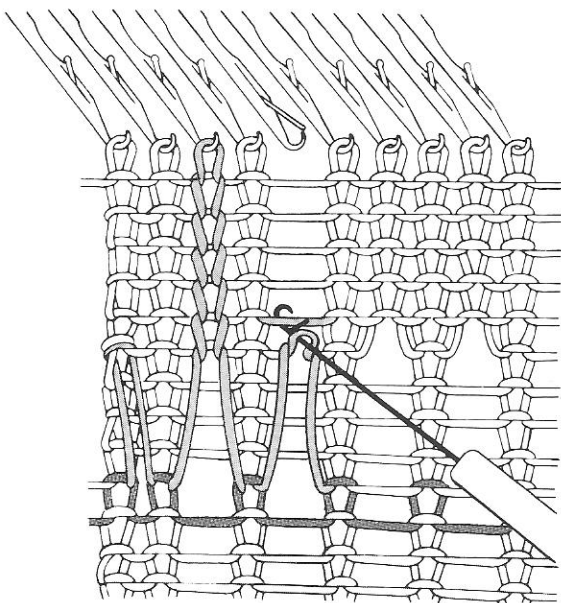

9. Catch the yarn on the next row crossing above and pull the Tappet Tool towards you.

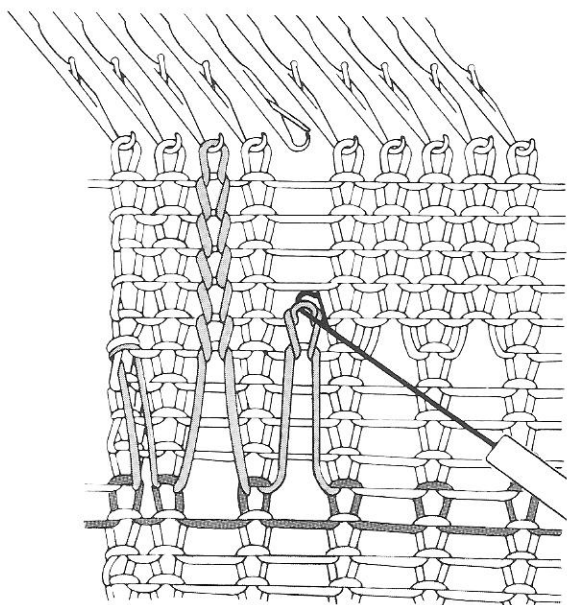

10. Repeat step 9 for every row.
Place the last stitch back onto its needle.
Reform every alternate stitch as above.

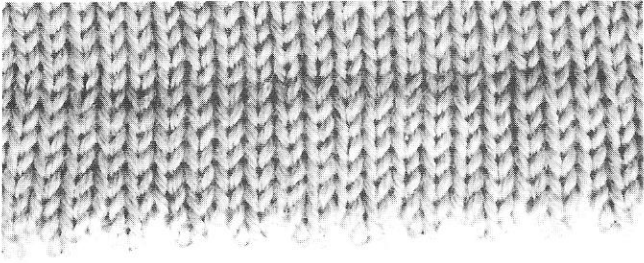

Picot Hem

1. Arrange required number of needle in B position and push back every other needles to A position.

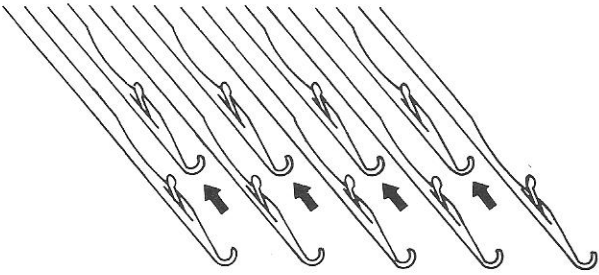

2. Cast-on and knit several rows of waste knitting, then knit 1 row with the Ravel Cord "A".

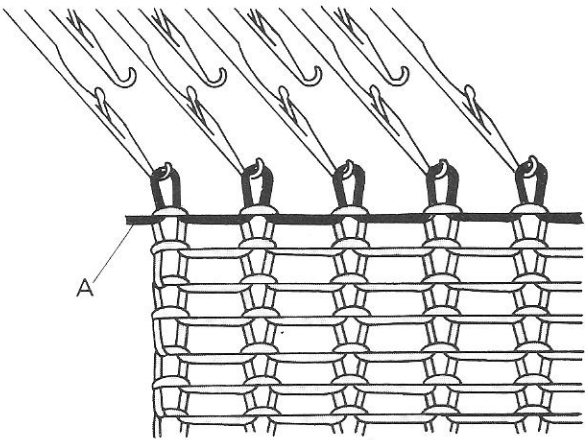

3. Set the Stitch Dial 2 full numbers lower than for Plain stitch and knit with the main yarn 2 rows fewer than required for the depth of hem.

4. Bring the A position needles from step 1, to B position.

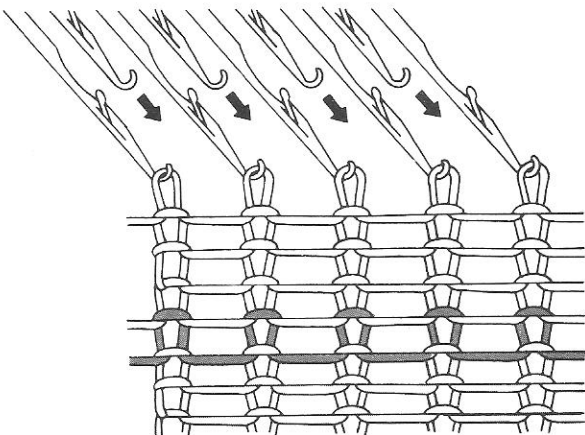

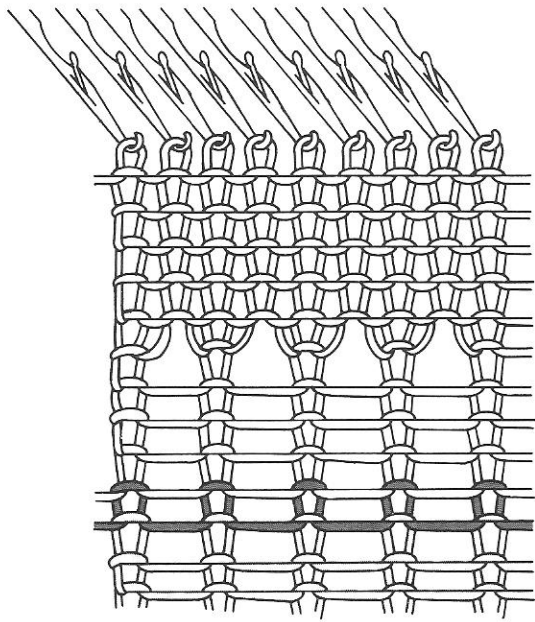

5. Reset the Stitch Dial to that originally used for Plain stitch knitting and knit required number of rows for the depth of the hem.

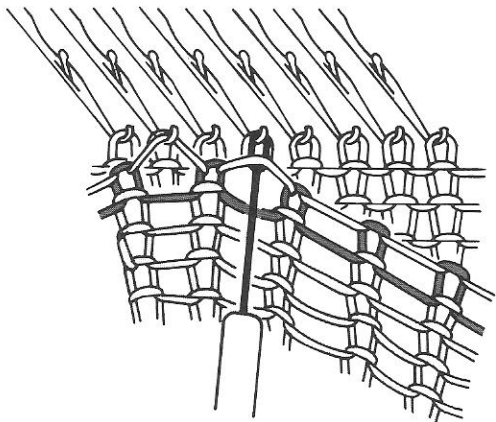

6. Place the sinker loops on the first row of the main knitting onto their corresponding needles. Pull out the Ravel Cord to remove the waste knitting.

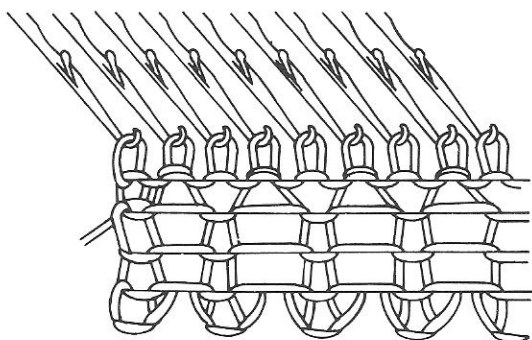

7. Set the Stitch Dial 1 full number higher than the number used for Plain stitch. Push the needles in B position to D position and knit 1 row.
8. Reset the Stitch Dial to the original number used for Plain stitch and continue to knit.

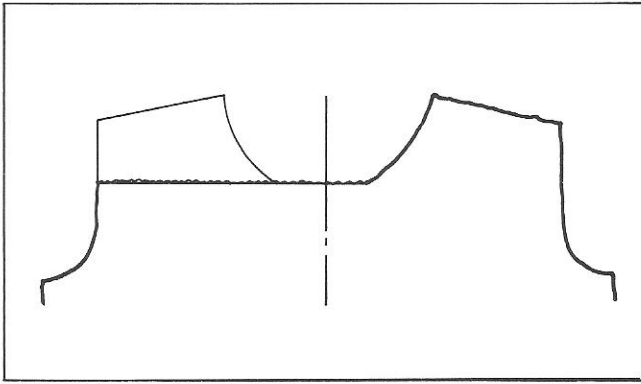

Holding stitches

If it is necessary to shape a garment in sections, use one of the following methods.

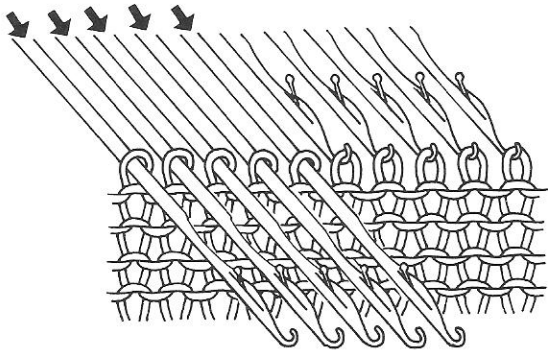

In D position:—

1. Push the needles for the section to be held to D position.

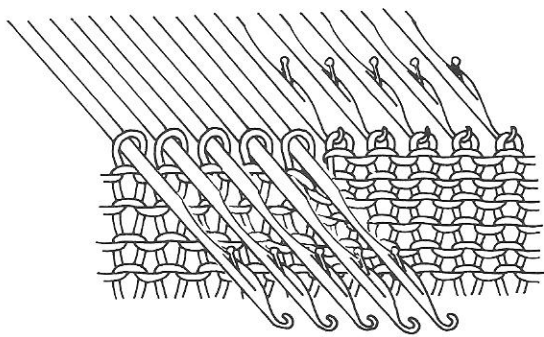

2. Set the Russel Levers to —, and continue to knit.

To continue knitting on the stitches which have been held, push the needles back to C position and continue to knit.

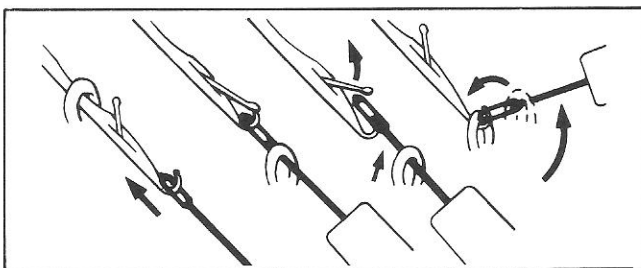

*When pattern knitting:—

Return the needles which have been held to B position using a Transfer Tool. Replace the stitches in the needle hooks.

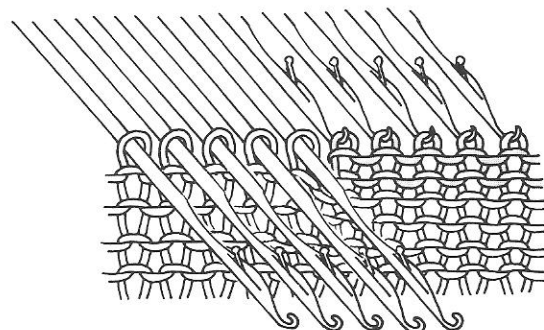

Waste yarn:—

Set the Pattern Dial to Plain stitch(0) and the Russel Levers to —.

1. Leave the needles for the stitches to be released on waste yarn in B position. Push the remaining needles to D position.

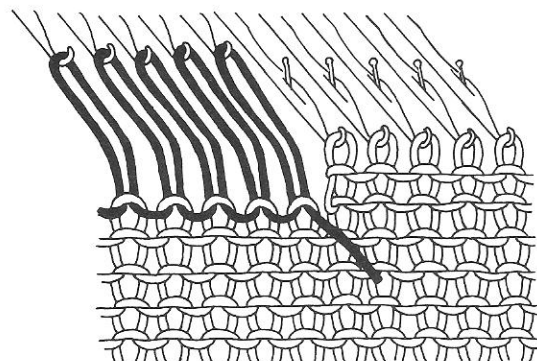
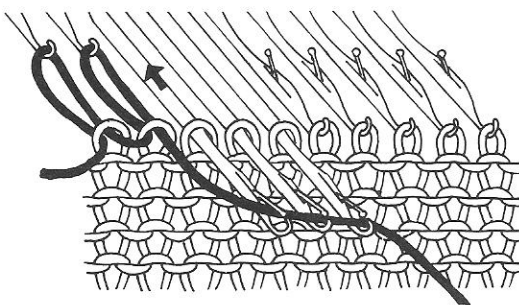
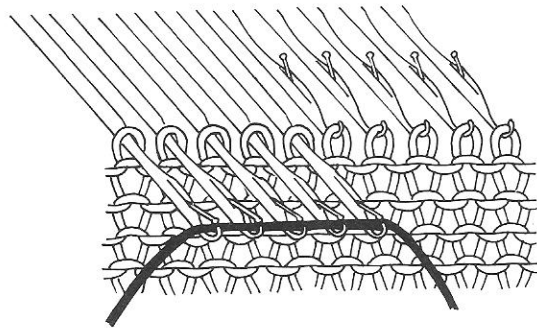
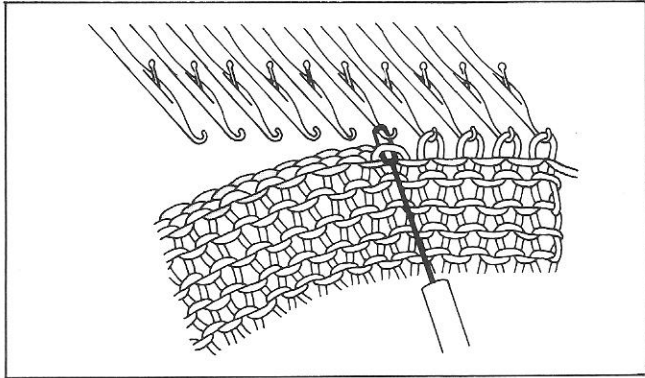
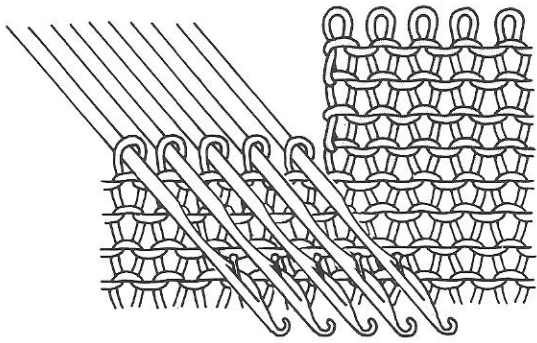

2. Thread waste yarn into the Yarn Feeder and knit several rows.
Remove this section from the machine.
3. Push needles from D position back to C position for Plain stitch, or return to B position for pattern knitting (Refer to page 53) reset the Carriage to the original settings and continue to knit.

To continue knitting the stitches held on waste knitting, pick up the stitches on the last row of the main knitting and place them onto the corresponding needles.

Using Ravel Cord:—

1. Push the needles for the section to be held, to D position, and lay the Ravel Cord in the hooks.
2. Starting with the end needle, push the needles back to A position manually.
3. Continue to knit.
Before starting each row, make sure that the needles are well back in A position.

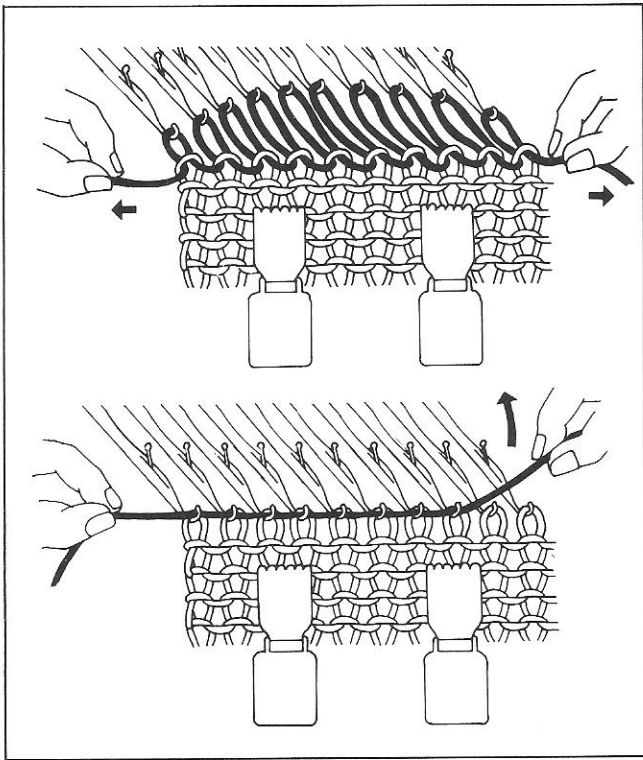

To return the needles to B position, hang Claw Weights on the fabric and replace the stitches in needle hooks by pulling the Ravel Cord.

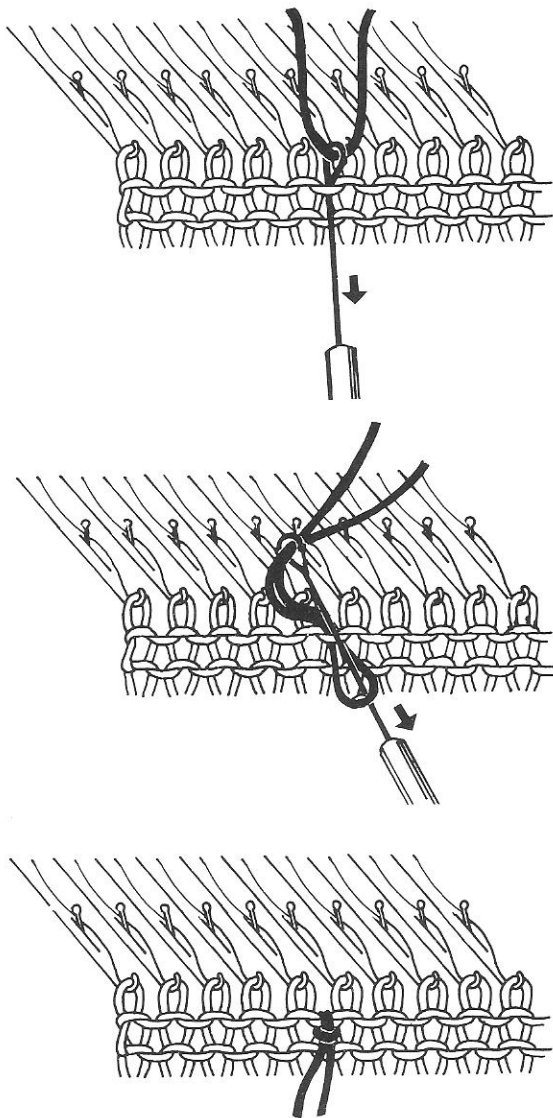

Put the yarn mark

Insert the Tappet Tool into the sinker loop to be marked. Take a length of waste yarn and make a loop on the Tappet Tool. Pull the Tappet Tool through the sinker loop.

Catch both ends of the waste yarn and pull out the Tappet Tool through the loop.

Buttonhole

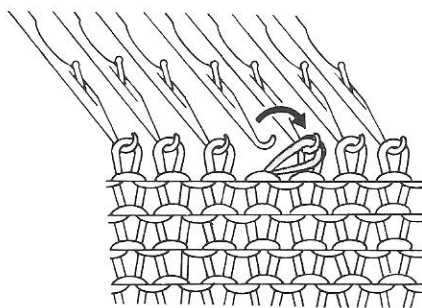

1. Place 1 stitch onto its adjacent needles.
Leave the empty needle in B position.

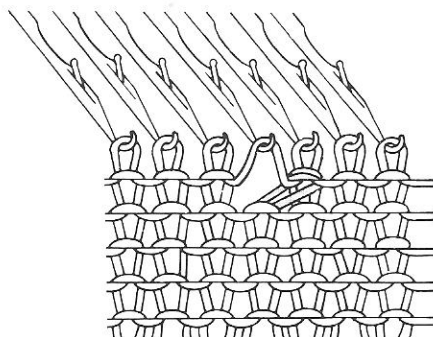

2. Knit 1 row.

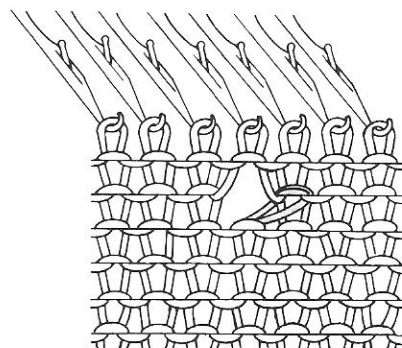

3. Continue to knit.

1 × 1 Rib

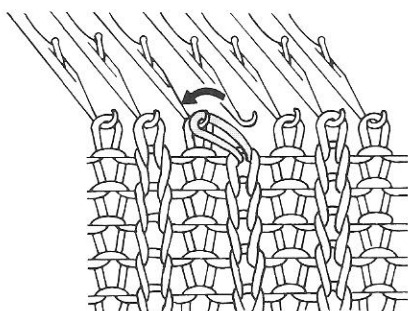

1. Reform the stitch for 1 × 1 Rib and place the stitch onto its adjacent needle.

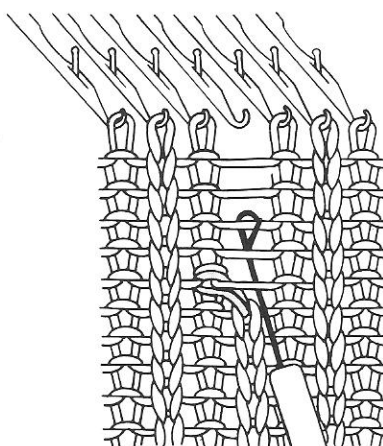

2. With the empty needle in B position, continue to knit. Unravel the row and insert the Tapper Tool behind the first two rows and hook the third row.

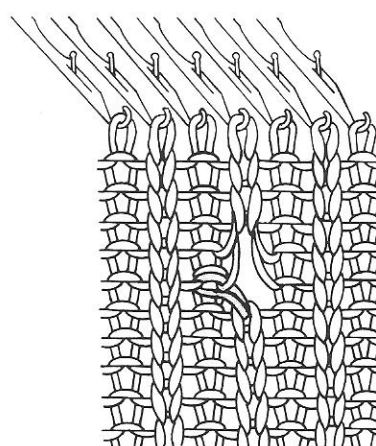

3. Continue to reform the stitches to 1 × 1 rib.
Use this side as wrong side.

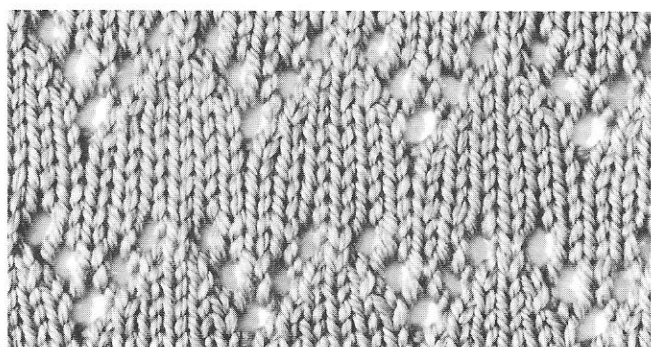

Openwork

1. Knit two rows in Plain stitch.
Using the Transfer Tool, transfer a stitch to its adjacent needle.
2. Leave the empty needle in B position. Continue to knit.

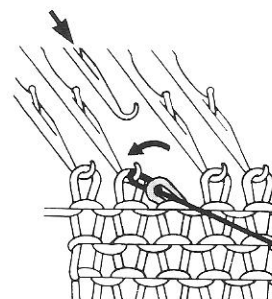
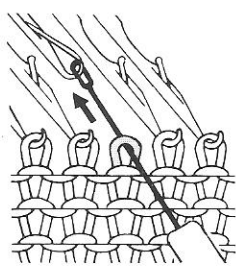
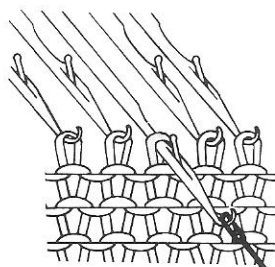

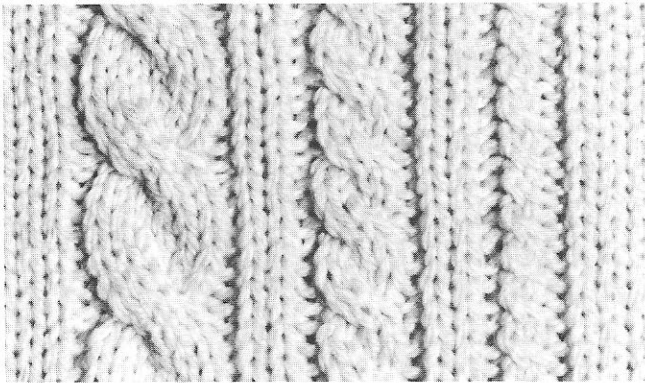

Cable Pattern

Cable patterns are formed by crossing a group of stitches over another group of stitches using two Transfer Tools.

Try a six stitch cable.

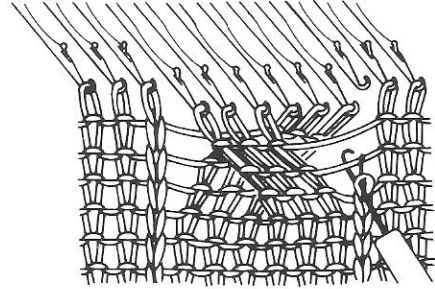
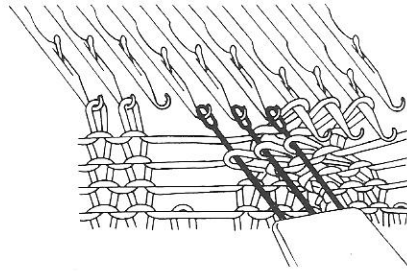
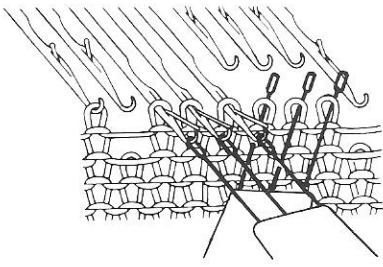

1. Drop one stitch at both sides of the 6 stitches to be cabled. Using two 3-prong Transfer Tools, remove the 6 stitches from their needles.
2. Cross the 2 Transfer Tools and replace each group of 3 stitches on their new needles.
3. Pick up the dropped stitches at the sides of the crossed stitches using the Tappet Tool, and replace them onto their original needles.
4. Before continuing to knit, push the 6 cabled needles to C position. Continue to knit to the next cable point, and repeat the above procedure.

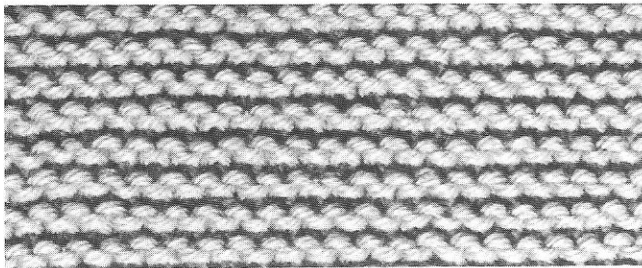

Garter Stitch

Garter stitch can be used for laps, collars, borders, etc.

Knit Plain stitch, purling the stitches every alternate row.

1. Set the Stitch Dial 2 numbers lower than for Plain knitting.
Knit 2 rows in Plain.

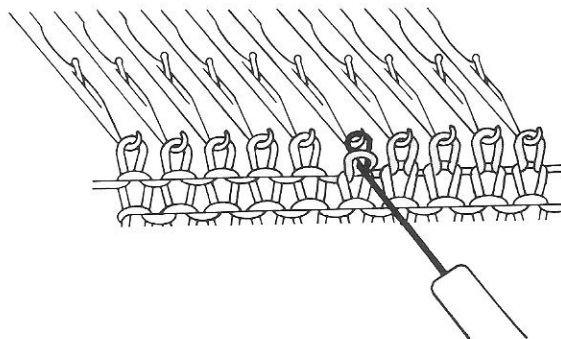
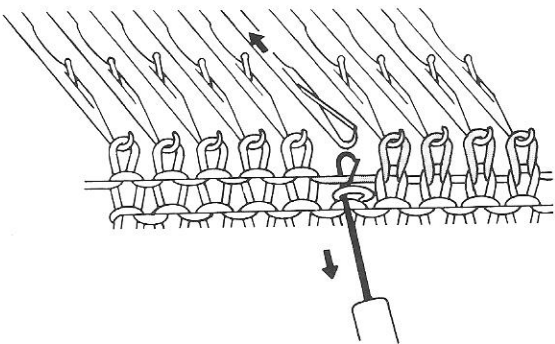

2. Insert the Tappet Tool into the stitch below the stitch on the needle, and push the needle to D position.
3. Push the needle back to B position, allowing the stitch to come undone. Catch the loop in the hook of the Tappet Tool, and pull the loop through the stitch already on the Tappet Tool.
4. Place the new stitch back on the needle.
Repeat steps 2 — 4 for all stitches on the row.
5. Knit 2 rows in Plain and re-form the stitches on the second row following steps 2 — 4.

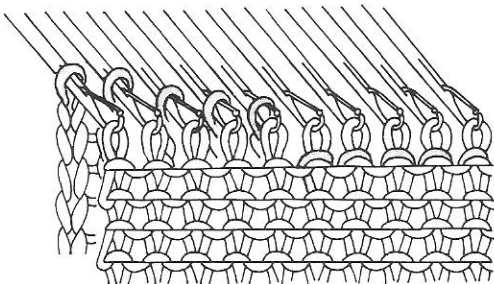
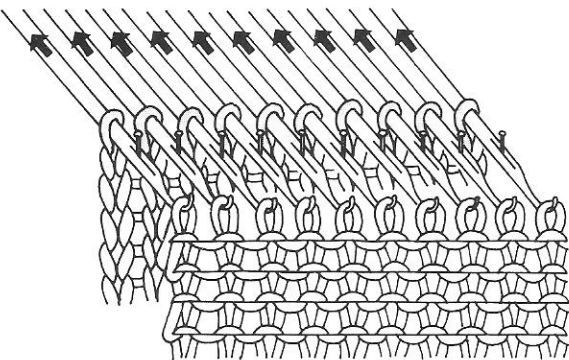
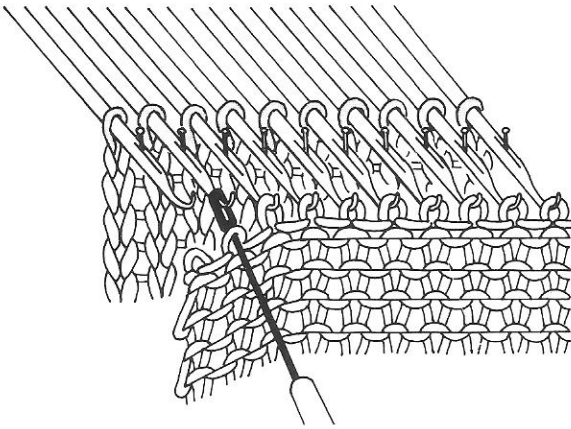
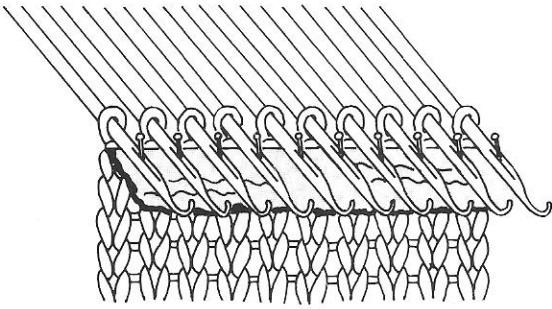
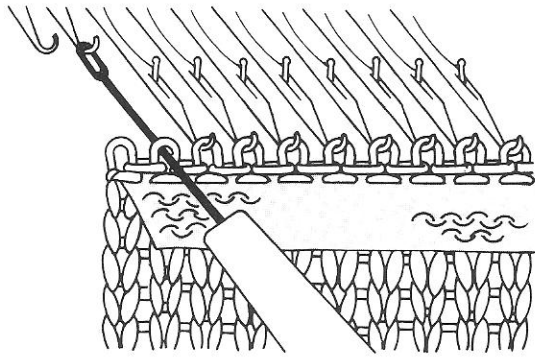

Joining on the machine

Stitch to Stitch

This is used for joining shoulders, joining a waistband to the waist edge, or joining a neckband to the neck edge.

1. With the plain side of the first piece facing you, pick up the stitches on the last row of the main knitting and place them onto the needles.
2. Push the needles to D position and bring the stitches of the fabric behind the latches.
Unravel the waste knitting.
3. With the purl side of the second piece facing you, pick up the stitches on the last row of the main knitting and place them onto the needles.
Unravel the waste knitting.
4. Push back the needles to B position.
5. The stitches behind the latches will slip off the needles, leaving one stitch inside the needle hooks.

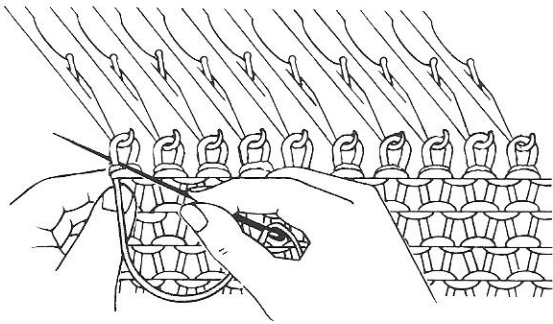
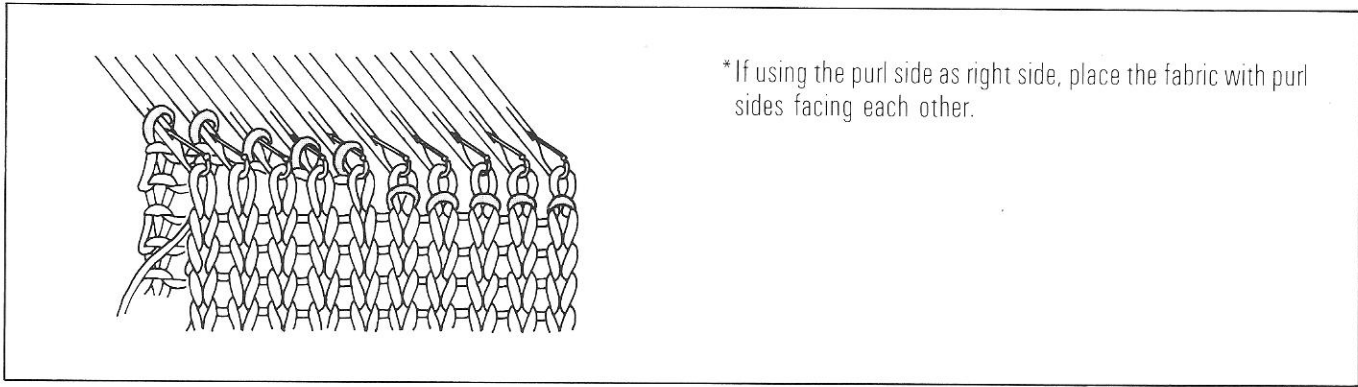

6. Cast off the stitches by using the Back Stitch Method.

Starting from the left:—

(1) Thread the Tapestry Needle and insert it into the first stitch and pull the yarn through.

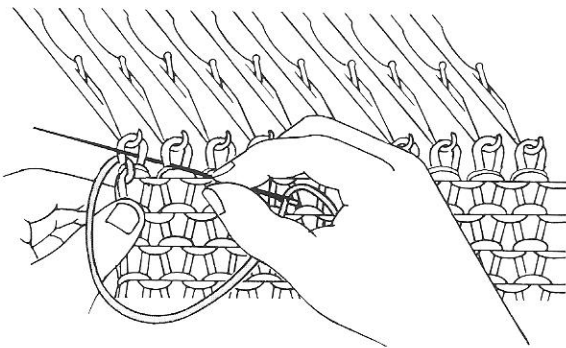

(2) Insert the Tapestry Needle in through the second stitch and out through the first stitch.

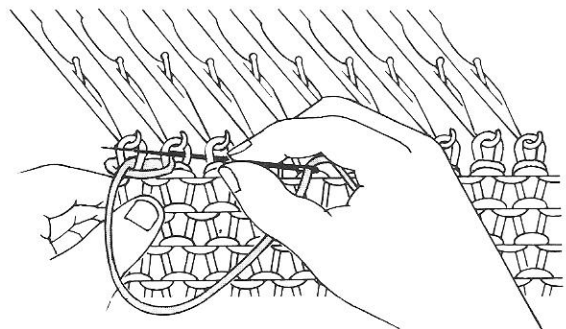

(3) Insert the Tapestry Needle in through the third stitch and out from the second stitch.

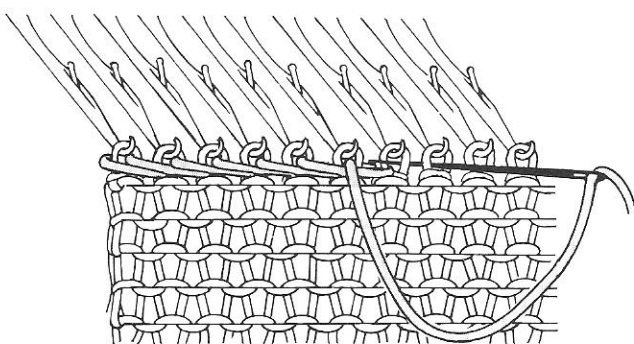

(4) Repeat steps (2) — (3).

Finish by pulling the yarn through the last stitch.

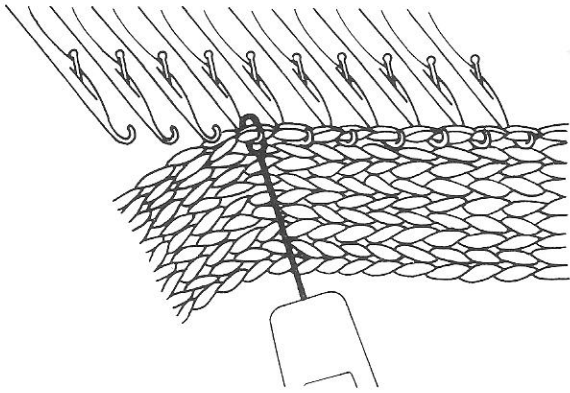

Open stitches to side edge

This is used for joining borders to the front edge of a cardigan, neckband to the neck edge, etc.

1. With the plain side of the first piece facing you, pick up the edge stitches, omitting a stitch at appropriate intervals, and place them onto the needles.

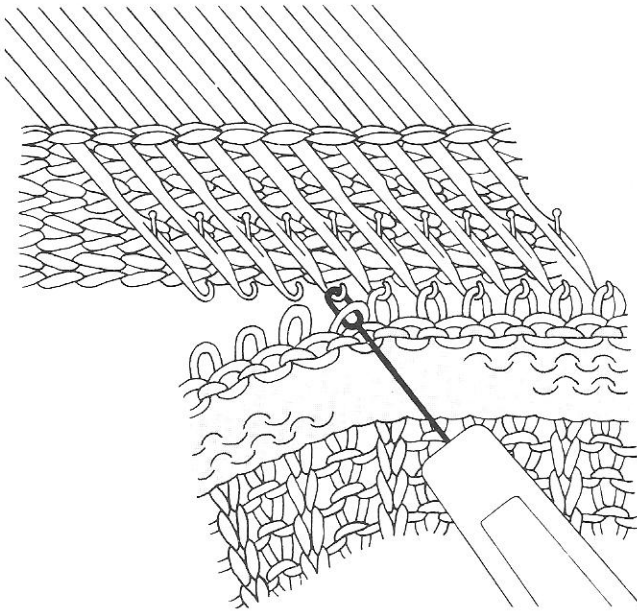

2. Push up the needles to D position. With purl side of the second piece facing you, pick up the stitches on the last row of the main knitting, and place them in the hooks of the needles.

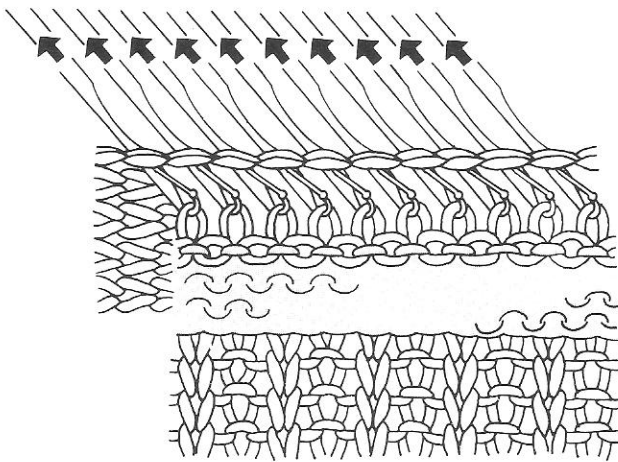

3. Push back the needles to B position, leaving one stitch in the needle hooks.

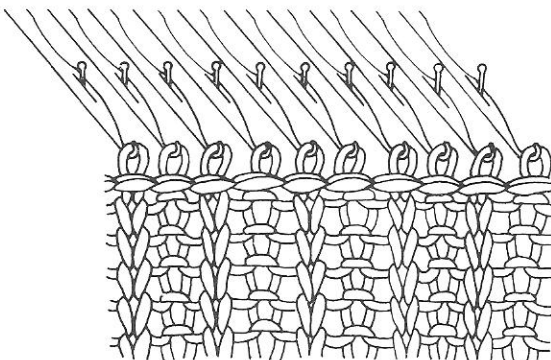

4. The edge stitches behind the latches will slip off the needles. Unravel the waste knitting.

5. Knit 1 row and cast off the stitches using the back stitch method. (Refer to page 60, step 6)

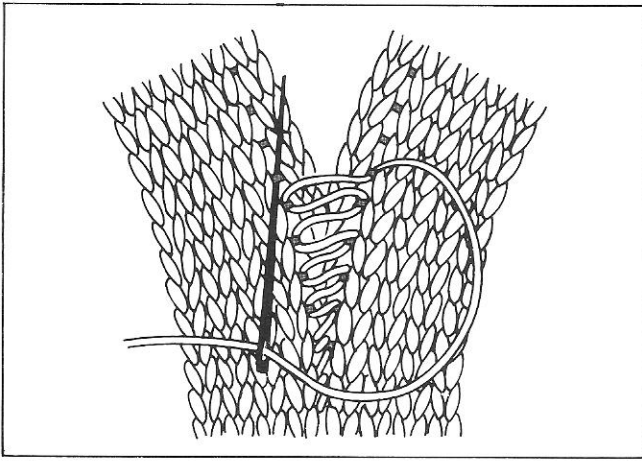

Joining by hand

Blind stitch

This is used for joining side seams.
Use a four ply yarn.

PLAIN SIDE AS RIGHT SIDE

With the plain sides facing you, pick up each sinker loop between the last 2 edge stitches. Repeat picking up the sinker loop from every row.

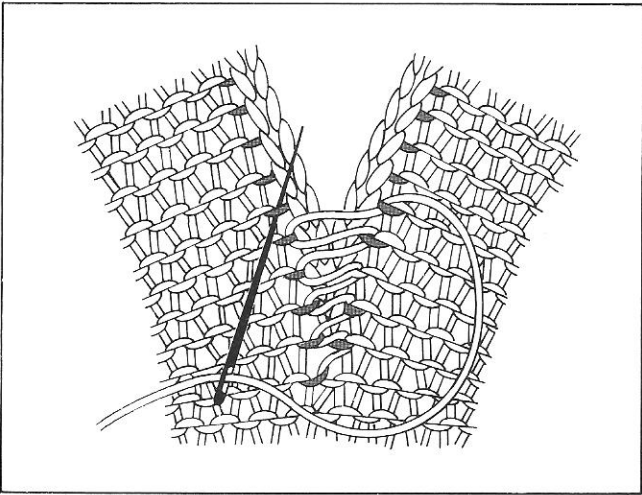

PURL SIDE AS RIGHT SIDE

With the purl sides facing you, pick up each sinker loop between the last 2 edge stitches.
Repeat picking up the sinker loop from every row.

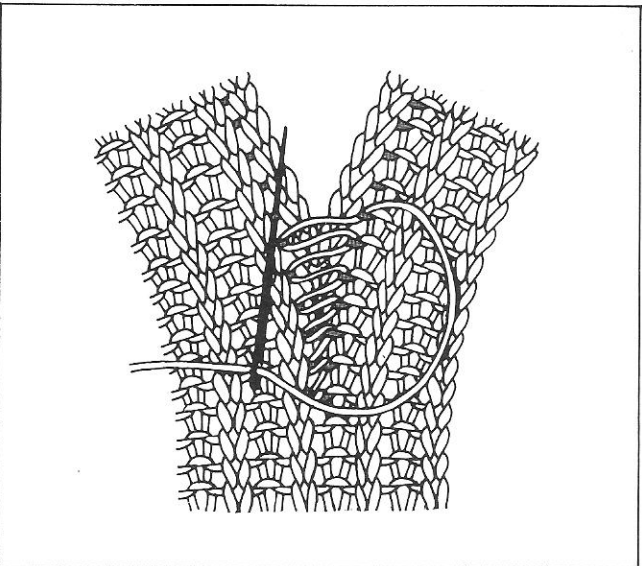

1 × 1 Rib

With the side to be used as the right side facing you, pick up the sinker loops between the last 2 edge stitches. Repeat on every row.

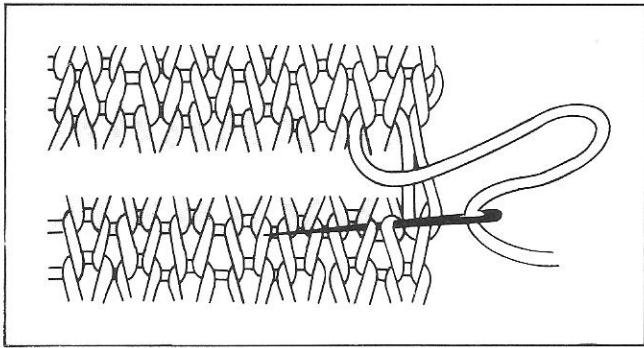

Grafting

This is used to join two open rows, where the seam should be soft to the touch.

Align both fabrics as shown and thread the knitting yarn through the stitches with the Tapestry Needle.

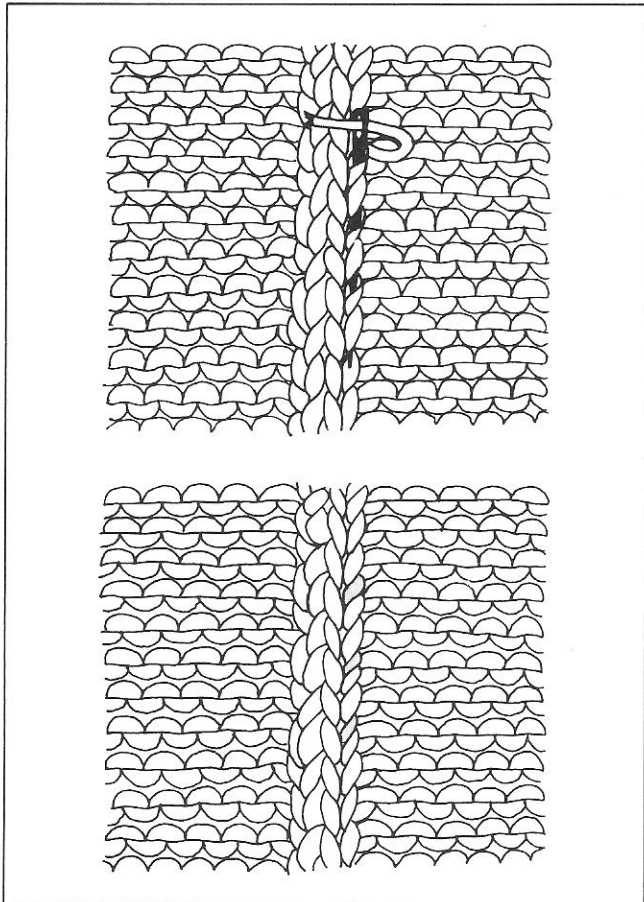

Sew in yarn ends

Oversew the yarn ends into the seam.

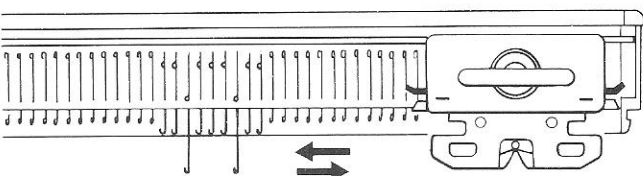
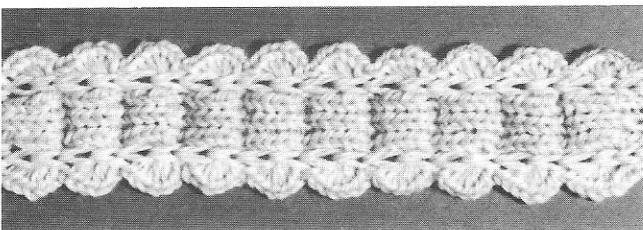
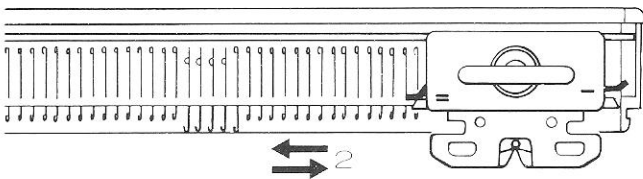
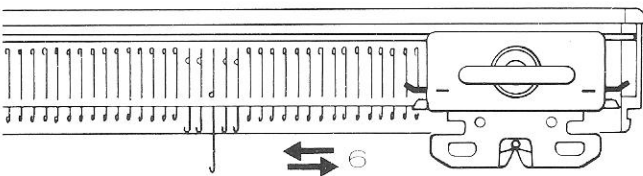
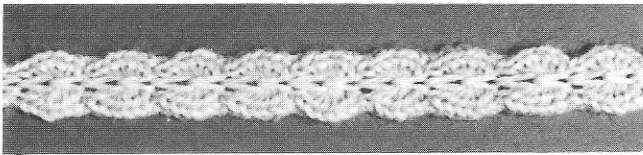
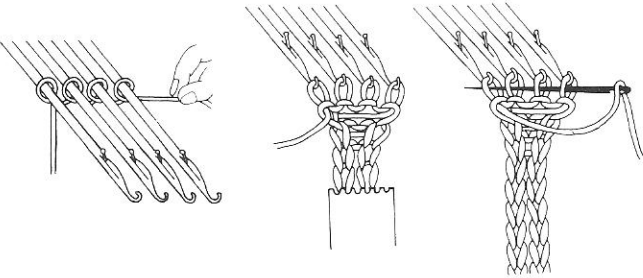
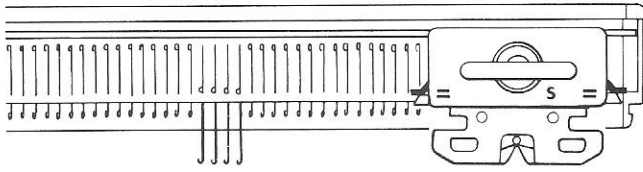
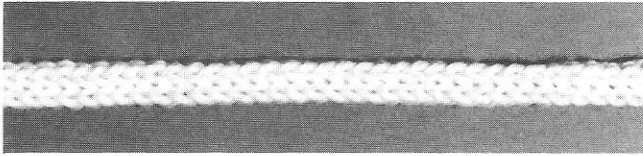

Cord knitting

1. According to the thickness of the cord you desire, push 3 — 5 needles to D position.
2. Set the Carriage as follows:—
 Pattern Dial..... S
 Russel Levers..... =
 Cast-on the stitches by winding method as illustrated.
3. Knit 2 rows
 (The Carriage knits the first row and passes the second row without knitting.)
4. Push up the needles to D position passing above the floating yarn.

Repeat steps 3 — 4.

After knitting several rows, hang a Claw Weights on the cord and continue knitting until the desired length has been knitted.

5. Cut the yarn leaving 10cm. and cast off the stitches with a Tepestry Needle as shown.

Braid

These braids are knitted in tuck stitch.
 Use medium thick yarn.

With 5 stitches

1. Cast-on 5 stitches and knit 5 rows of Plain stitch leaving the Carriage at right.
 Hang a Claw Weight and attach the Tuck Brushes.
 2. Set the Carriage as follows:—
 Pattern Dial..... 0
 Russel Levers..... — (both)
 3. Push the centre needle to D position and knit 6 rows.
 4. Set the left Russel Lever at =, knit 2 rows.
 5. Reset the left Russel Lever to —.
- Repeat steps 3 — 5.

With 9 stitches

Cast-on 9 stitches and knit in the same manner as instructed in "with 5 stitches". But push up third needle from both sides and knit 6 or 8 rows in step 3.

HELPFUL HINTS

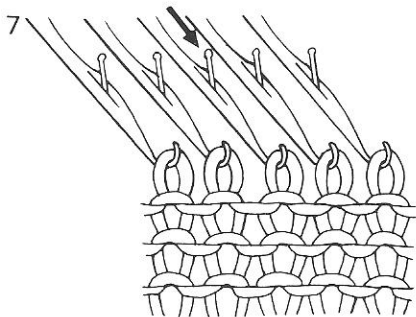
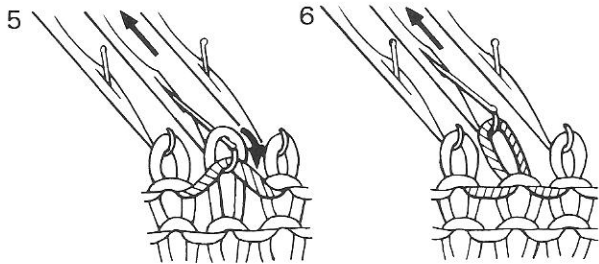
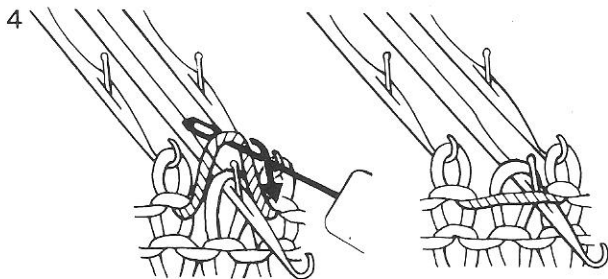
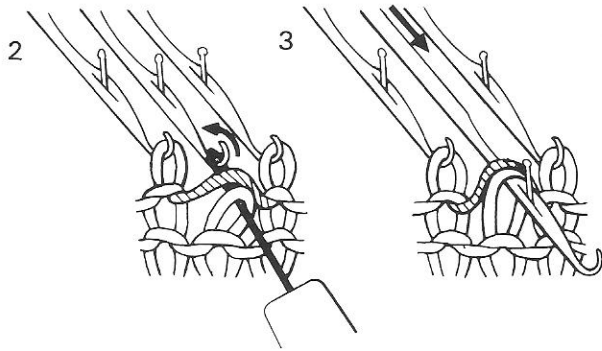
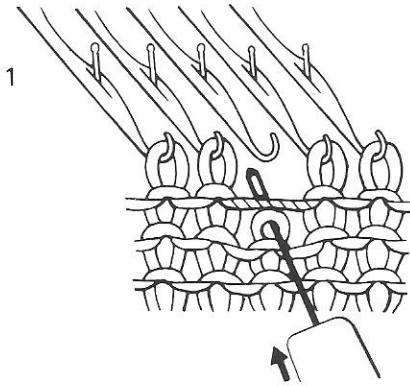

To pick up a dropped stitch

1. Insert a prong of Transfer Tool into the dropped stitch.

2. Replace the stitch onto the empty needle together with the bar above the stitch.

3. Push forward the needle till the stitch and the bar move behind the latch.

4. Lift up the bar using the Transfer Tool and bring it in front of the latch.

5. Push back the needle till the stitch behind the latch slips off the needle.

6. Push the needle back to A position to correct the size of stitch.

7. Align the needle correctly in B position.

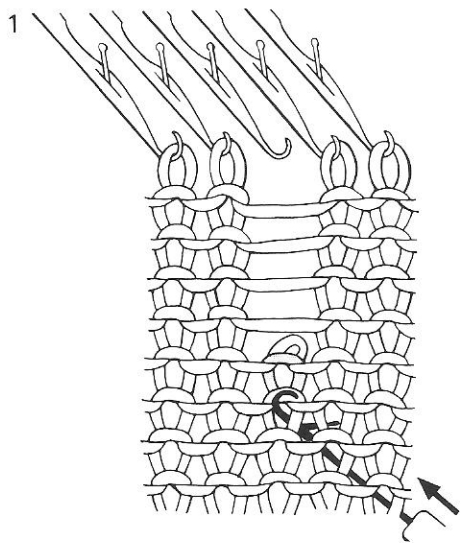

If a dropped stitch has run down for several rows...

1. Insert the Tappet Tool into a stitch a few rows below the dropped stitch from the rear side.
Let the stitch run down to the Tappet Tool.

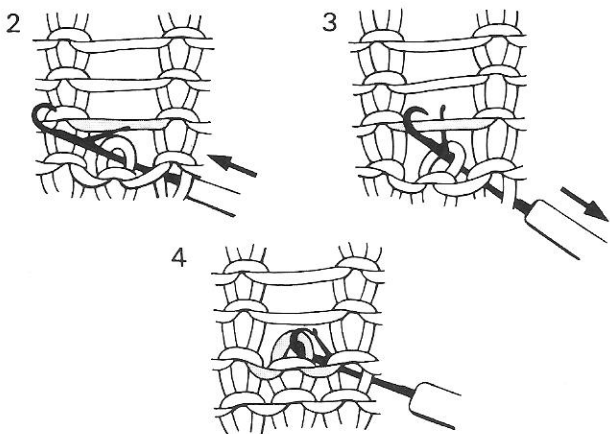

2. Push forward the Tool till the stitch moves behind the latch of the Tool.
3. Pull the Tool back, catching the bar above.
4. The stitch behind the latch slips off the Tool and knits through the bar in the hook.

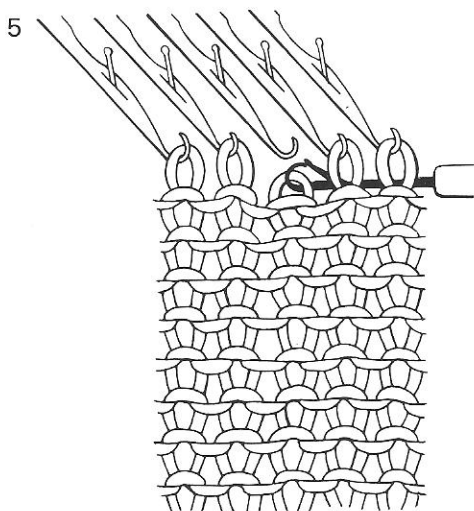

5. Repeat up to the top stitch.

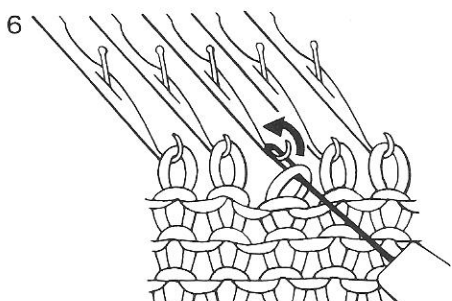

6. Take the top stitch onto the Transfer Tool at the front, and replace it in the empty needle hook.

If one or more stitches have dropped or when in pattern knitting, it is usually easier to unravel the rows, rather than to repair the stitches.

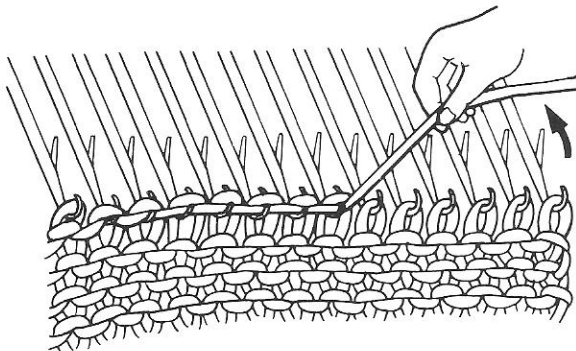
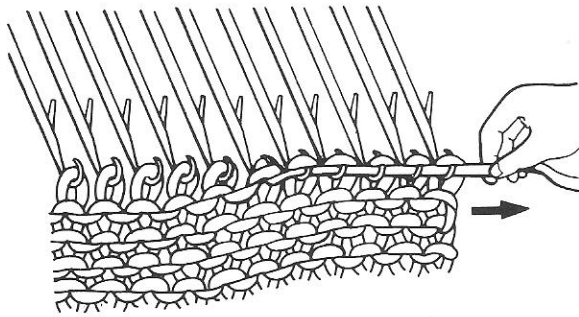

To unravel knitted fabric on the machine

Remove the Carriage from the knitting before you start to unravel. (If the Carriage has jammed, see page 68.)

Remove yarn from the Yarn Feeder.

Hang Claw Weights on both edges of the knitting.

1. Holding the fabric downwards, pull the yarn sideways to tighten the stitches.
2. Lift the yarn upwards and very slightly backwards. The stitches of the previous row will slip back into the needle hooks.
3. Align the needles in B position.
4. To continue knitting, pull the unravelled yarn down towards the yarn ball at the back of the Tension Rod, move the Carriage to the same side as the yarn end. Adjust the Row Counter, and replace the yarn in the Yarn Feeder.

If the fabric has been shaped by decreasing or partial knitting.

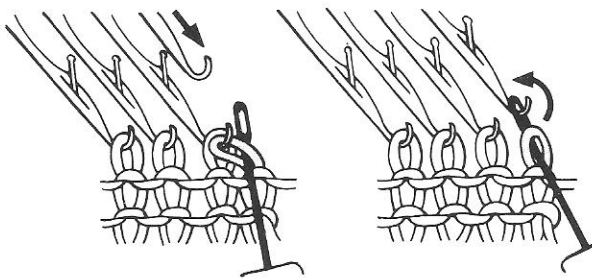

Fabric with decreased edge:—

On the decreased edge, the end needle has two stitches. Place one stitch back on its original needle.

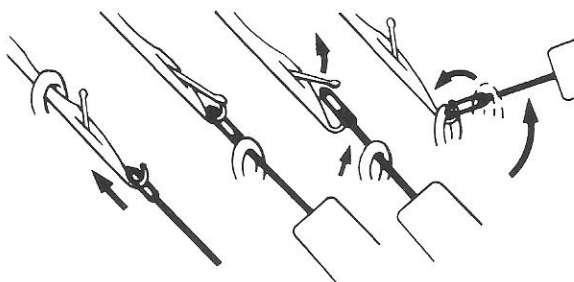

In the course of partial knitting:—

Replace the stitches in the needle hooks. Return the needles from D position to B position using Transfer Tool.

Sunset Bay Partners & Assoc, Inc / The Knitting Closet

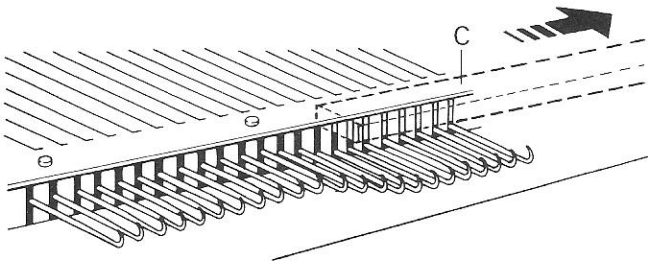
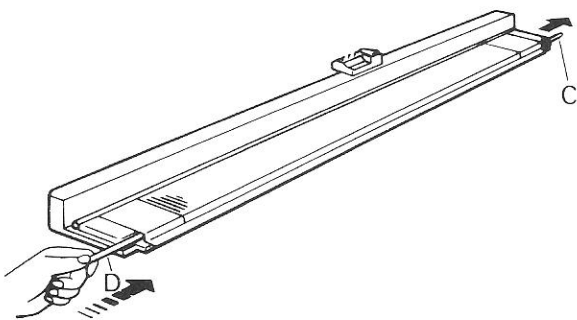
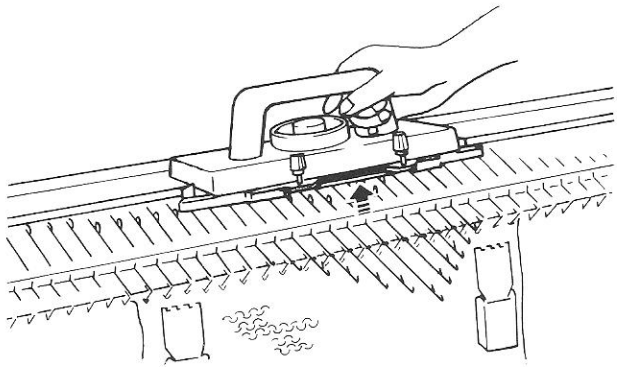
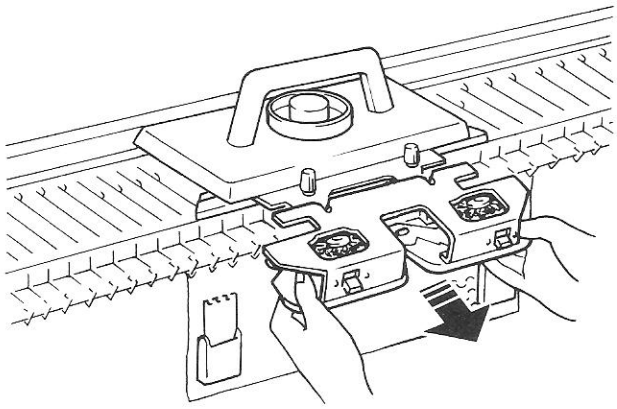

If the Carriage has jammed...

In the middle of the row, do not push the Carriage by force. Proceed as follows to release the Carriage from the jam.

1. Disengage the Row Counter Lever.
2. Remove the yarn from the Yarn Feeder.
3. Loosen both Arm Nuts and remove the Arm from the Carriage.
4. Lift the front of the Carriage and move it in the same direction to clear the working needles.
5. Pick up any dropped stitches.
(see pages 65~66)
Return the needles in C or D position to B position replacing the stitches in the needle hooks with a Transfer Tool. Unravel the incomplete row and move the Carriage to the same side as the yarn. (Refer to page 67.)
6. Replace the Arm and Tuck Brushes if they are in use. Adjust the Row Counter and raise the Row Counter Lever.
7. Insert yarn and continue knitting.

To replace a damaged needle

A needle with a damaged latch or a bent hook will cause incorrect knitting or dropped stitches. The needle latch "A" must move smoothly and lie flat over the hook "B".

Do not remove needle retainer bar when needles are in D position.

1. At each side of the Needle Bed, you can see the Needle Retainer "C".
If the damaged needle is at the left of Needle Bed, move the Carriage to the right.
Use a pencil "D" to push the Needle Retainer from the left. The Needle Retainer is then pushed out of the Needle Bed at the right end and you can pull it out of the Needle Bed until the damaged needle is free.

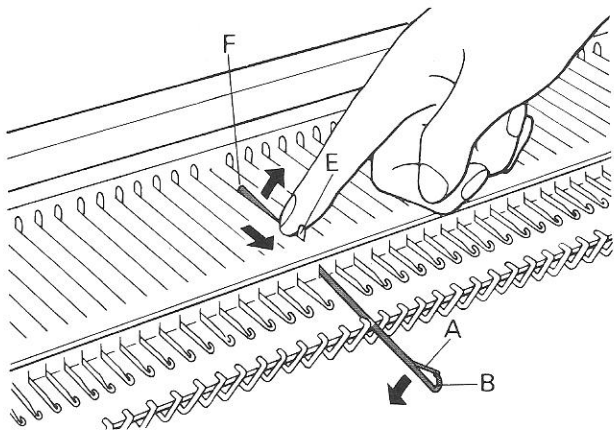

2. Push the damaged needle to D position by pressing its butt "E". Close the latch "A" and press the hook "B" down. The shank "F" will then come out of the needle groove.

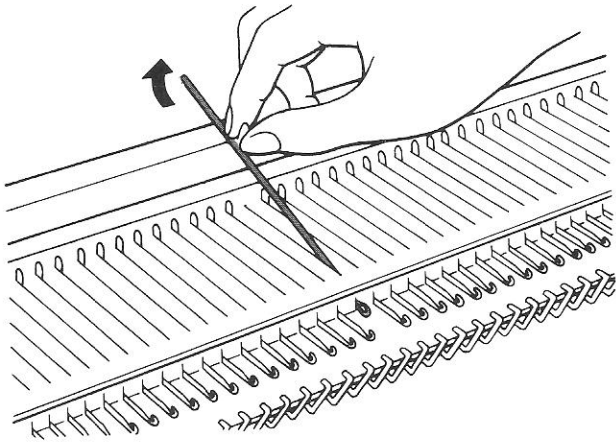

3. Lift up the needle by holding the butt and pull back to remove from the Needle Bed.

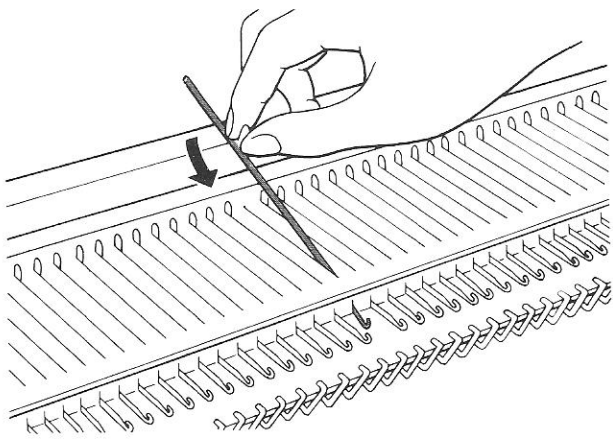

4. To fit a new needle, open the latch and slide it into Needle Bed slot until the hook comes out of the front of the Needle Bed.

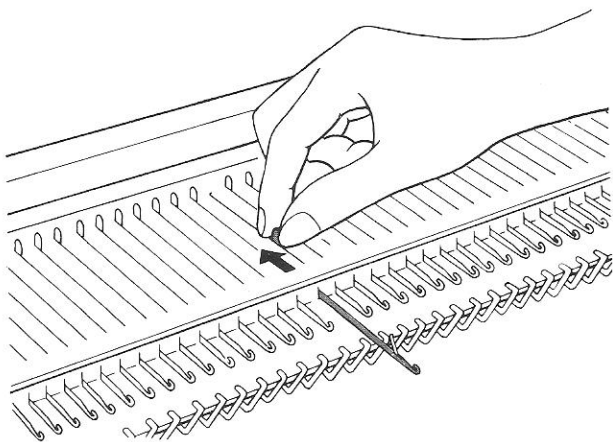

5. Push the needle back to A position by holding the butt.

6. Push the Needle Retainer back into the Needle Bed.

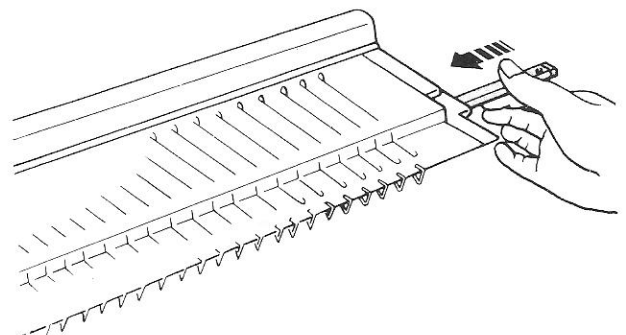

MAINTENANCE

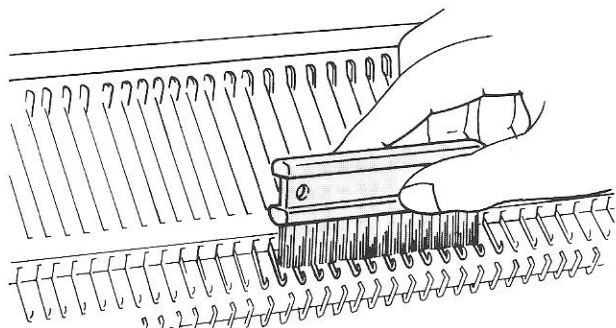

To clean your Knitter, remove the Carriage from the Needle Bed.

NEEDLE BED

Remove all fluff using the Cleaning Brush.

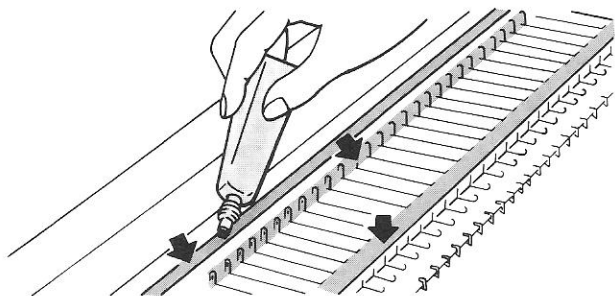

Apply oil along the rail and front guide of the Needle Bed.

With a soft oiled cloth, wipe needle butts.

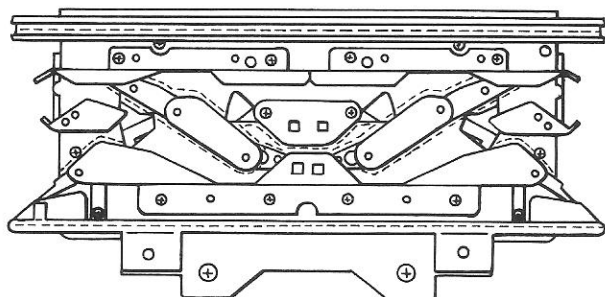

CARRIAGE

Turn over the Carriage and brush off all fluff and oil from the metal parts, slider, Rail guide and Arm.

Replace the Carriage on the Needle Bed.

REPACKING THE KNITTER

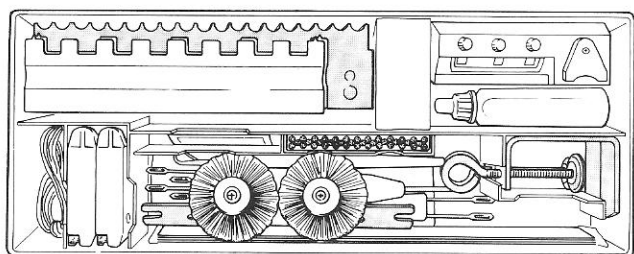

Replace the Accessories in the Accessory Box.

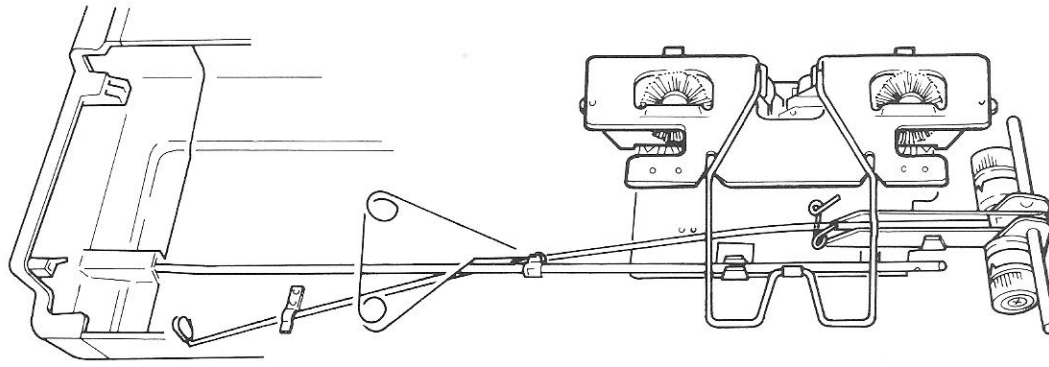

Remove the Auto Tension and Arm from the Knitter and pack them inside the Top Cover.

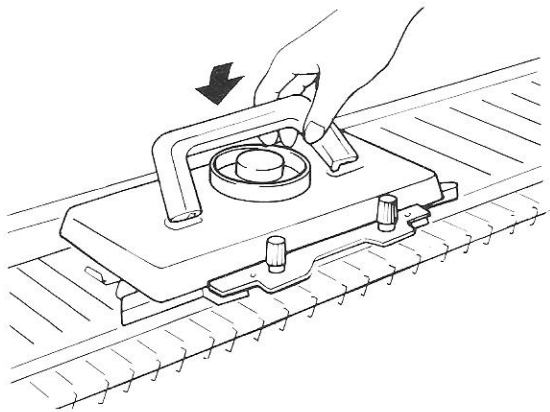

Lay the Carriage Handle down.

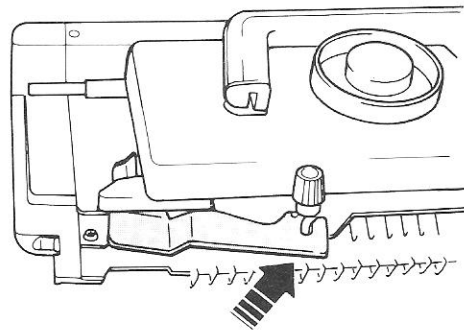

Secure the Carriage to the Needle Bed with the Carriage Fastener.

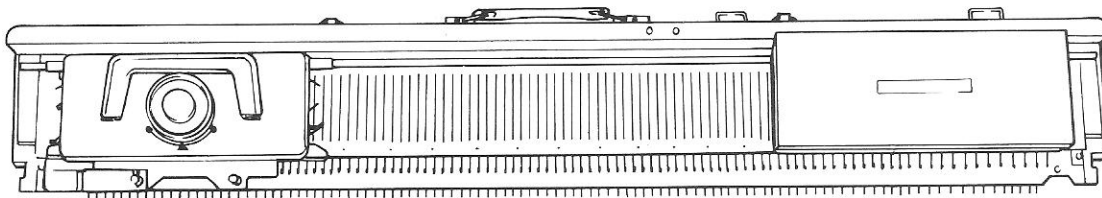

Place the Accessory Box on the right end of the Needle Bed.

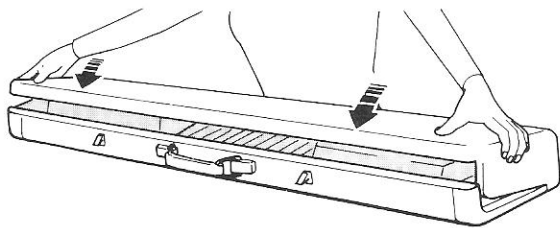

Place the Top cover onto the Needle Bed.

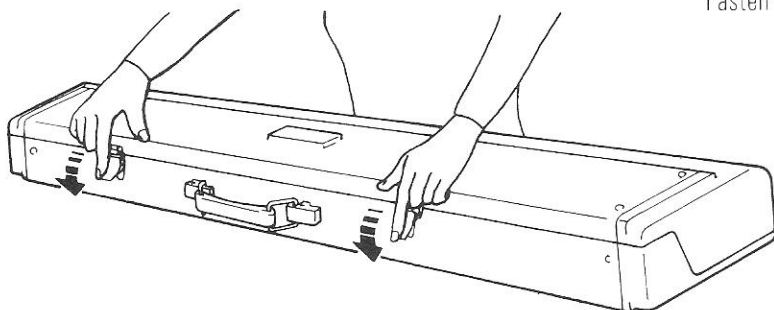

Fasten the latches.

TO STORE THE MACHINE

Keep the machine away from.

1. Too much moisture.
2. Abnormal change of temperature.
3. Salt or chemicals.