

# **SERVICE MANUAL**

**FOR TOYOTA PUNCH CARD KNITTER**

**MODEL KS787 AND KR460**

C O N T E N T S

PART I - MECHANISM AND FUNCTION

1. Names of External Appearance -----	1
2. Names of Main Structure -----	2
3. Principle of Needle Selection -----	8
4. Principle of Knitting -----	17

PART II - SERVICE GUIDE FOR TROUBLES

1. Replacement Procedure of Selection Pin -----	20
• Assembling Needle Supporting Plate -----	22
• Assembling Selection Pin Spring Securing Plate -----	22
• Assembling Needle Bed to Needle Bed Base Plate -----	23
• Assembling Needle Supporting Plate Stopper -----	24
• Adjustment of Needle Bed Position -----	25
2. Replacement of Selection Plates -----	27
3. Replacement Procedure of Manual Plates -----	29
4. Positioning of Selection Plates/Adjustment of Selection Pin Securing Plate -----	32
5. Adjustment of Needle Seizing Plate Position -----	35
6. Adjustment of Card Feeding Mechanism -----	36
7. Adjustment of Card Ratchet and Card Feed Cam -----	37
8. Replacement Procedure of Needle Retaining Spring ---	38
9. Adjustment of Jacquard Operating Plate -----	39
10. Replacement of Jacquard Operating Plate -----	41
11. Adjustment of Manual Plate Position -----	42

---

PART III - DIMENSION OF CARRIAGES

1. Dimension of Main Bed Carriage -----	44
2. Dimension of Yarn Feeder -----	45
3. Dimension of Lace Carriage -----	46
4. Dimension of Ribbing Carriage (KR460) -----	48

NAMES OF EXTERNAL APPEARANCE

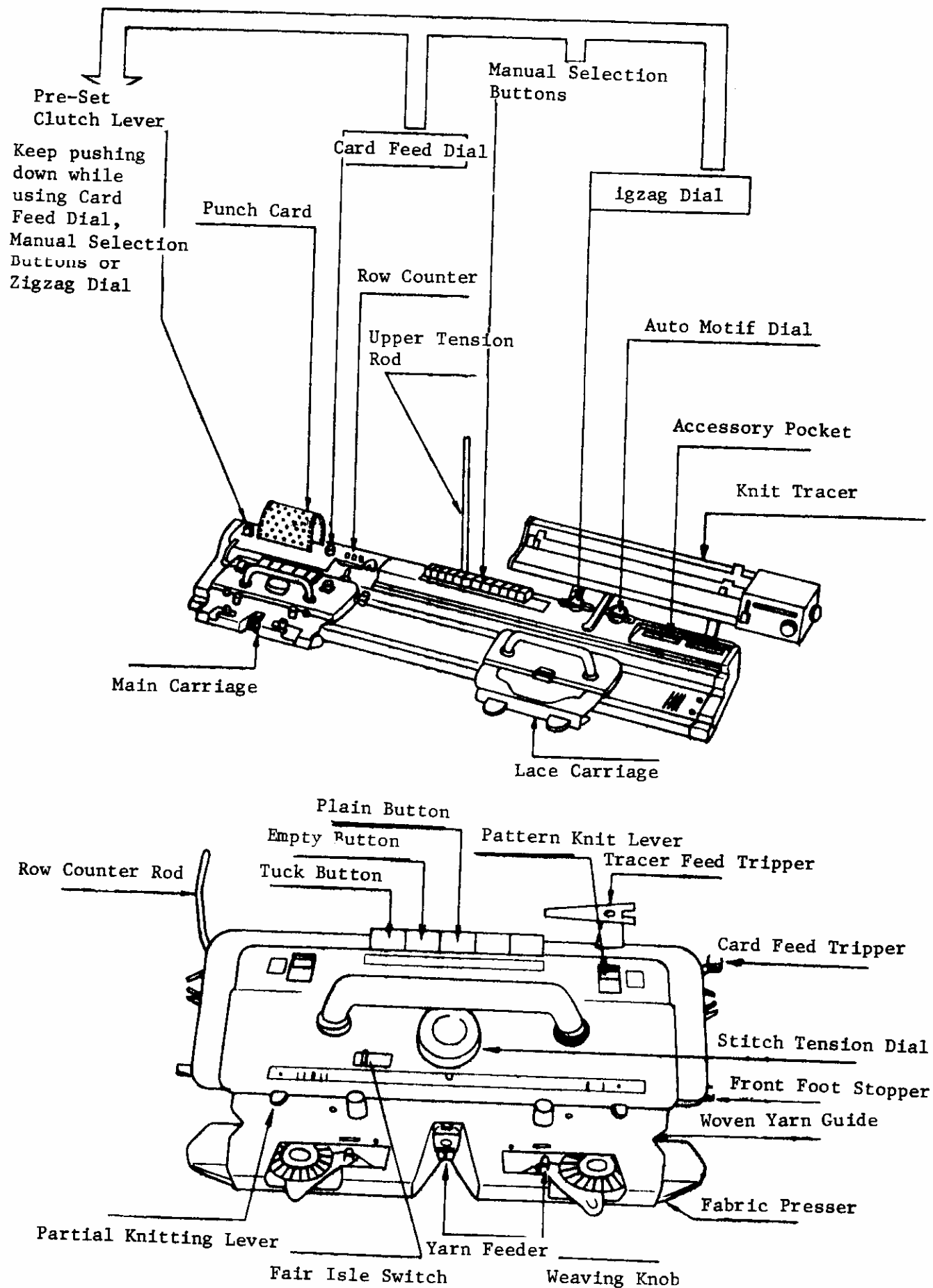

[NAMES OF MAIN STRUCTURES]

1. FRONT SIDE OF MAIN CARRIAGE

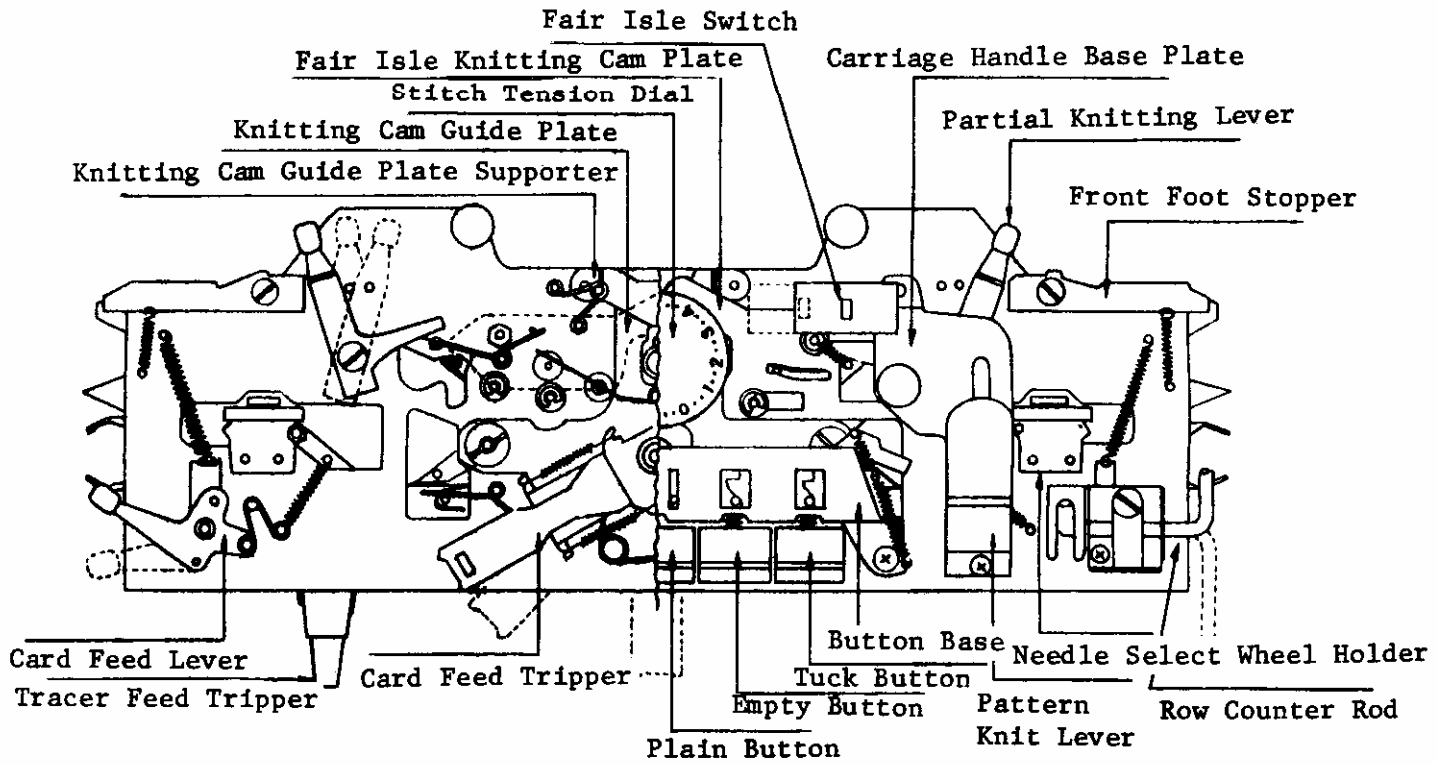

FUNCTION

Names	Setting	Sort of Knitting	Operated Cam						
Card Feed Lever	Advances	Card Pattern Selection	Card Feed Lever Plate Card Feed Tripper						
	Stops	Manual/Non Selection							
Pattern Knit Lever	Pattern	Auto/Manual Selection	Pattern Switch Cam						
	Plain	Non Selection							
Partial Knitting Lever	"II"	Tuck Stitch	Induction Cam "						
	"I"	Partial Stitch							
	"0"	Plain Stitch							
Fair Isle Switch	Colour	Fair Isle Knitting	Fair Isle Knitting Cam Variable Cam						
	Plain	Other Knittings							
Tuck Button	Pushed	Tuck Pattern Knitting	Raising Cam, Tuck Cam						
Empty Button	Pushed	Slip Loop Knitting	Raising Cam						
Stitch Tension Dial	Adjusted According to sort of yarn		Knitting Cam						
	Names	Cotton		Fine	Soft Strand 2ply	Fine Medium 3ply	Medium 4ply	Thick 2ply	Thick 3ply
	Tension Dial	2-4		1-3	1-3	2-4	3-5	5-6	4-6
	Lace Knitting	4-5		3-4	3-4	4-5	5-6	5-6	5-6
	Names	Crepe 5(4)ply		6ply	Crepe 8ply	*Crepe 12ply	Boucle	Mohair	Tweed
Tension Dial	5-7	6-8	8-9	8-10	4-6	4-6	4-6		
Lace Knitting	6-7	(7-8)	-	-	4-6	4-6	-		
*use every other needle									

2. BACK VIEW OF MAIN CARRIAGE

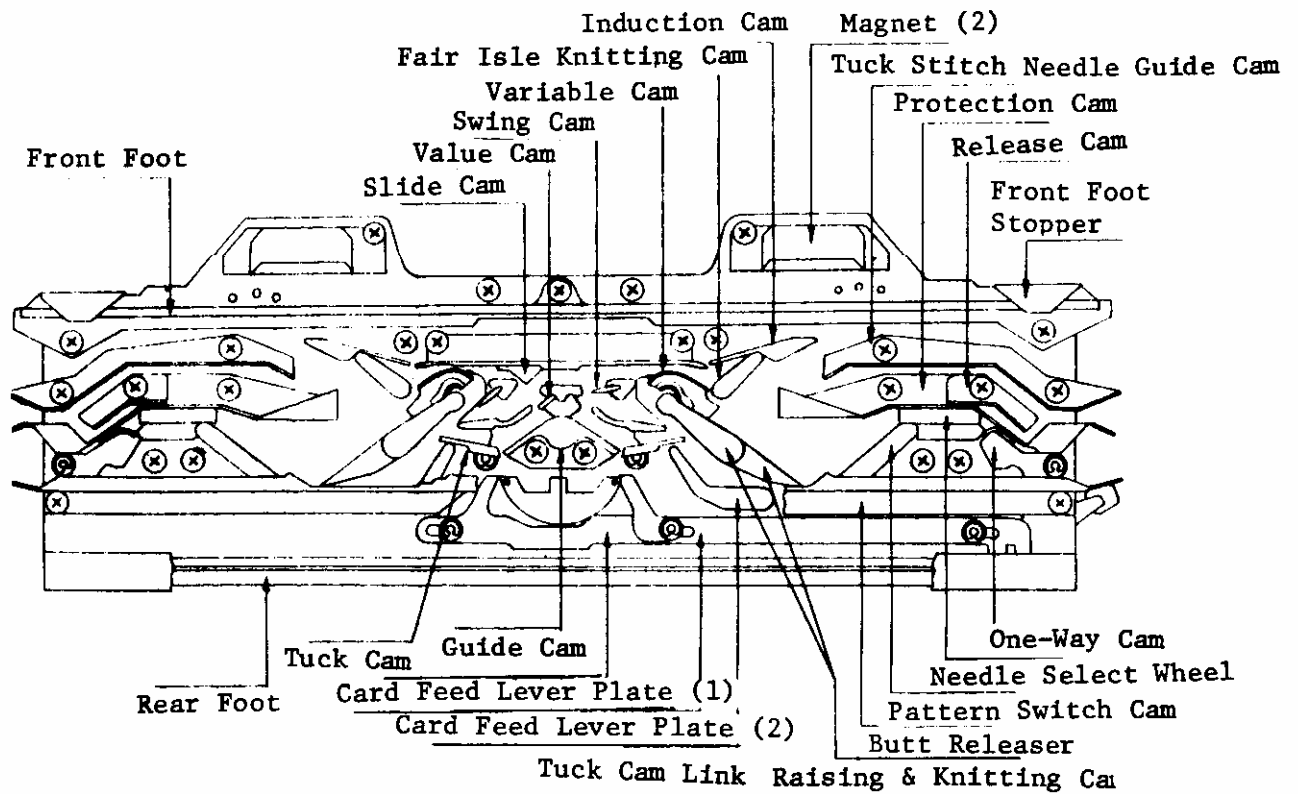

3. FABRIC PRESSER

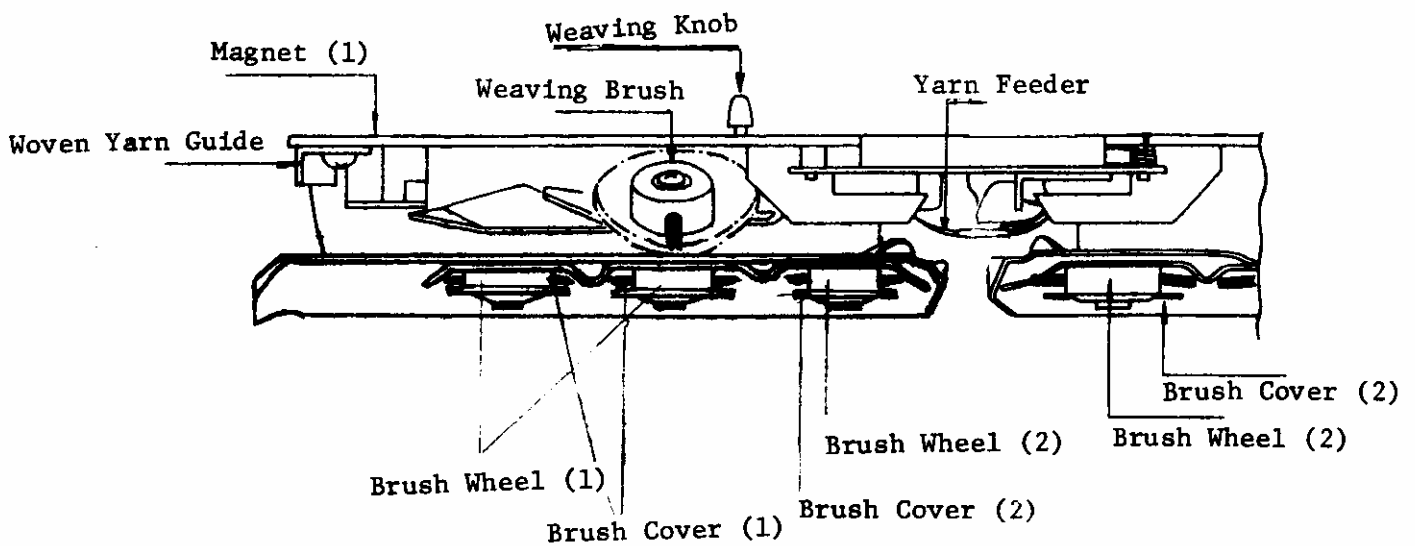

4. BODY STRUCTURE

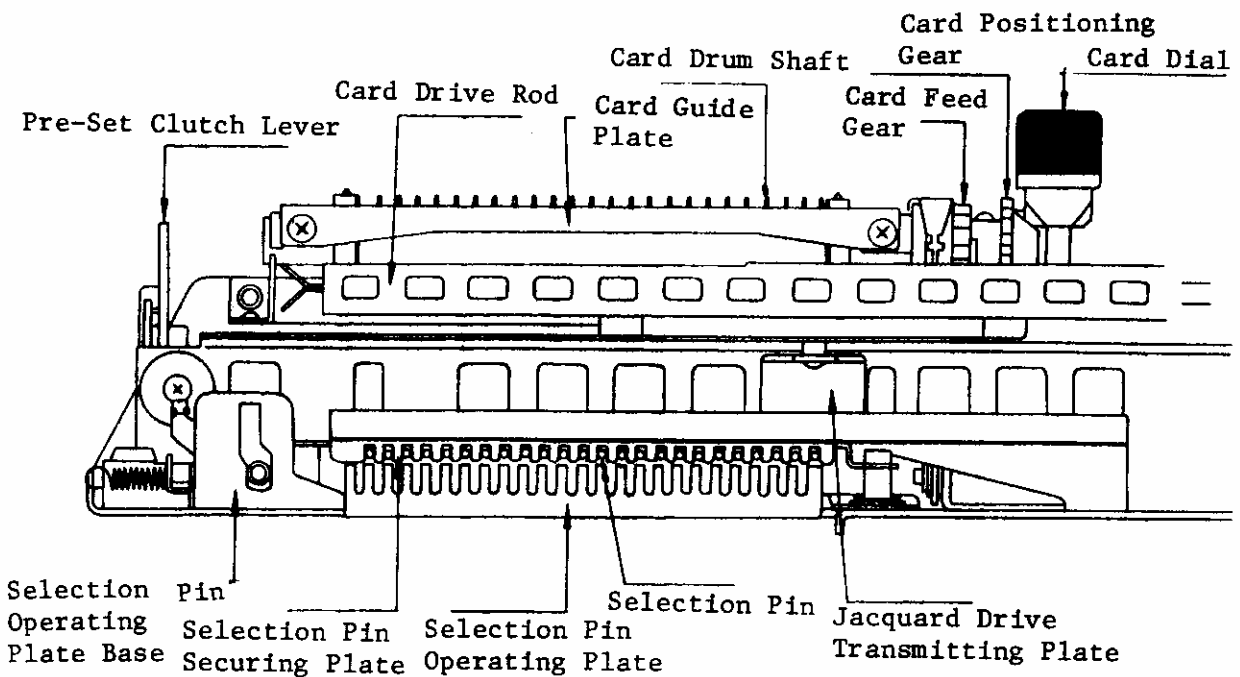
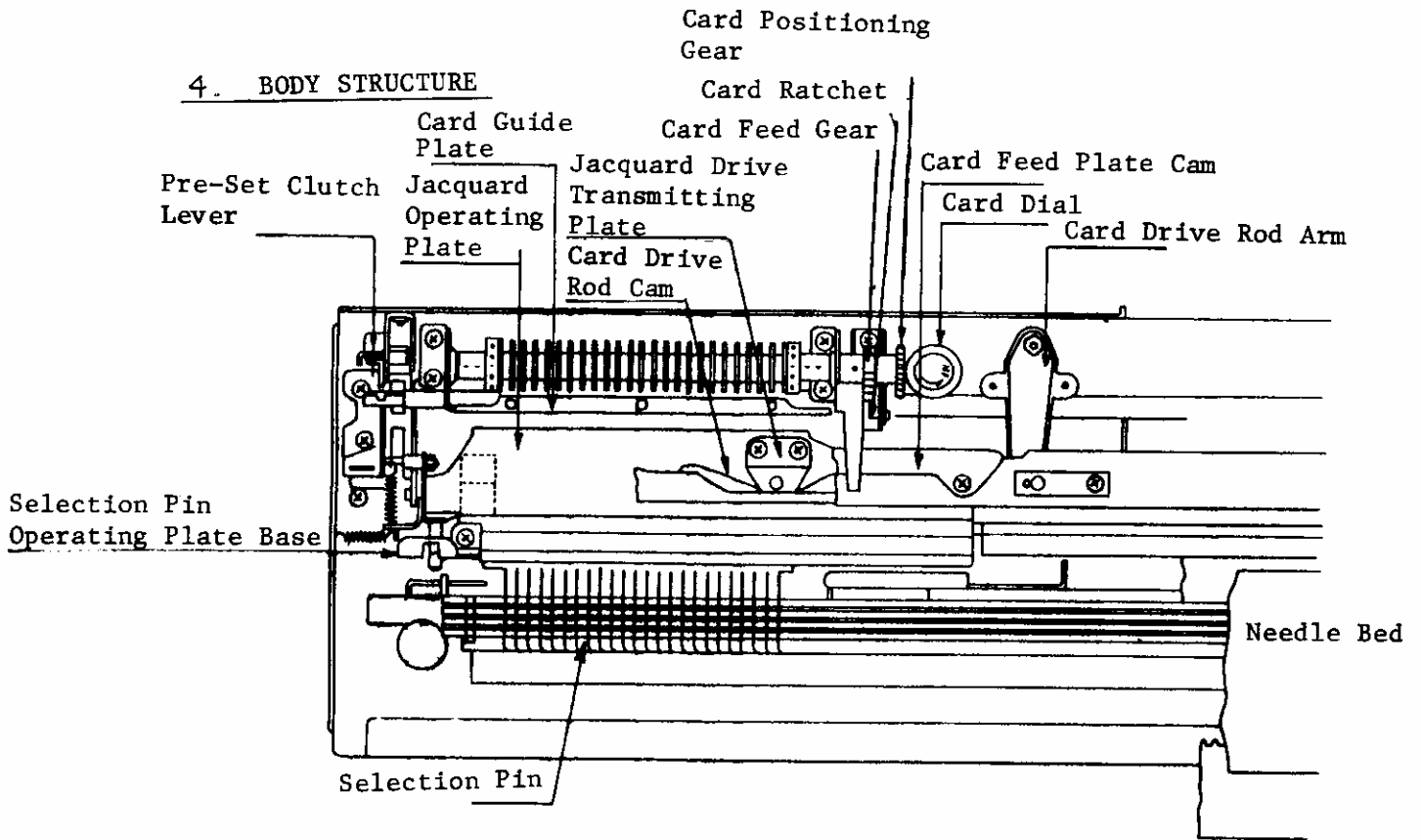



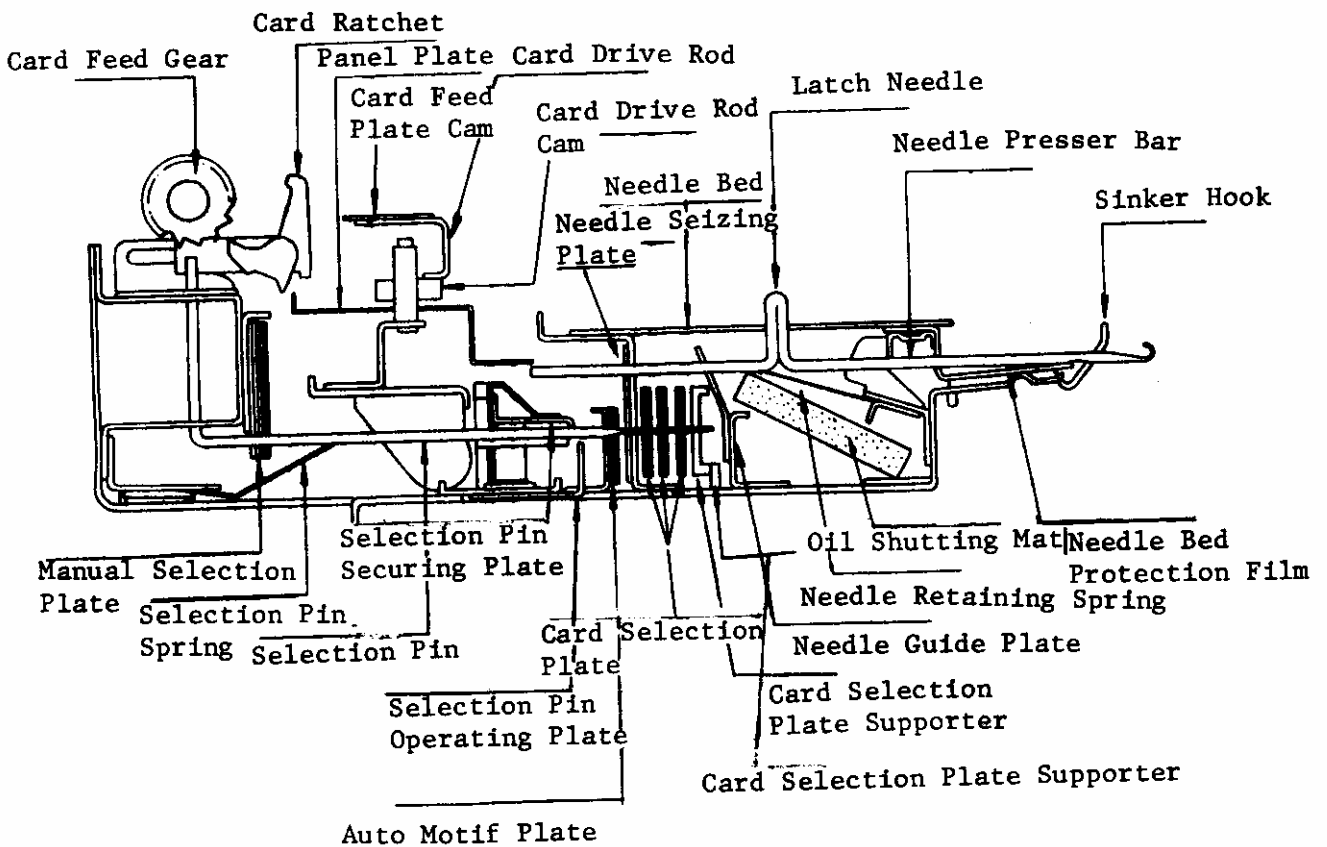
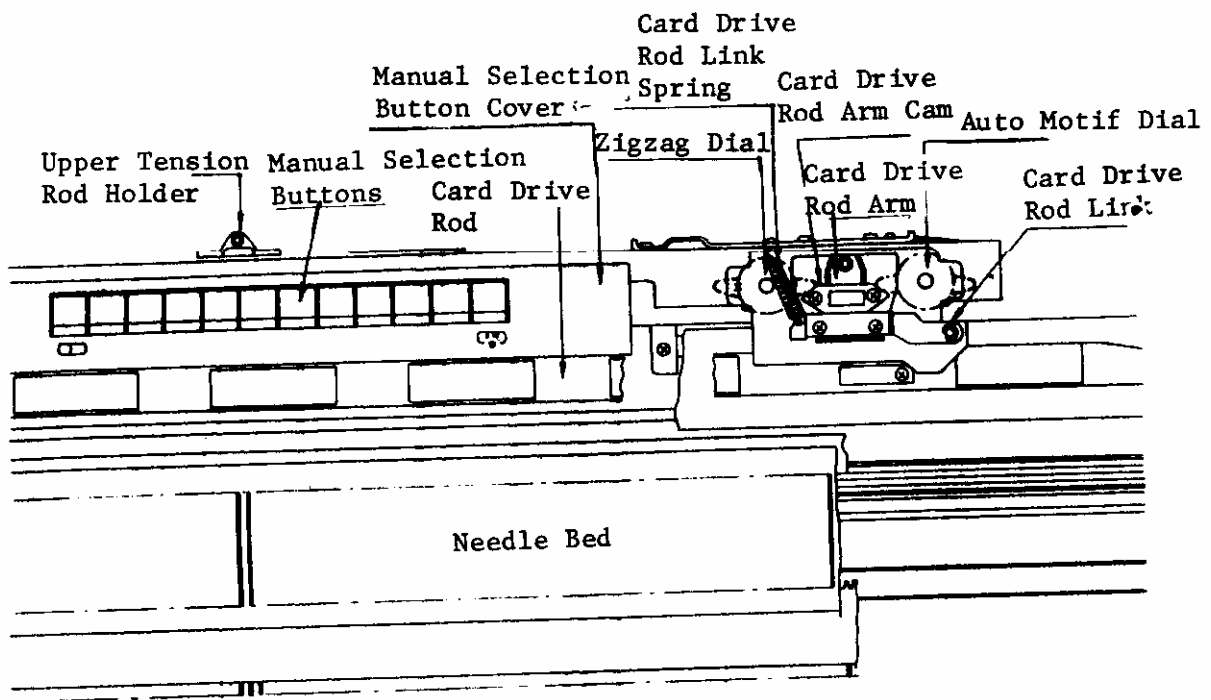

NAMES AND DIMENSIONS OF LATCH NEEDLE

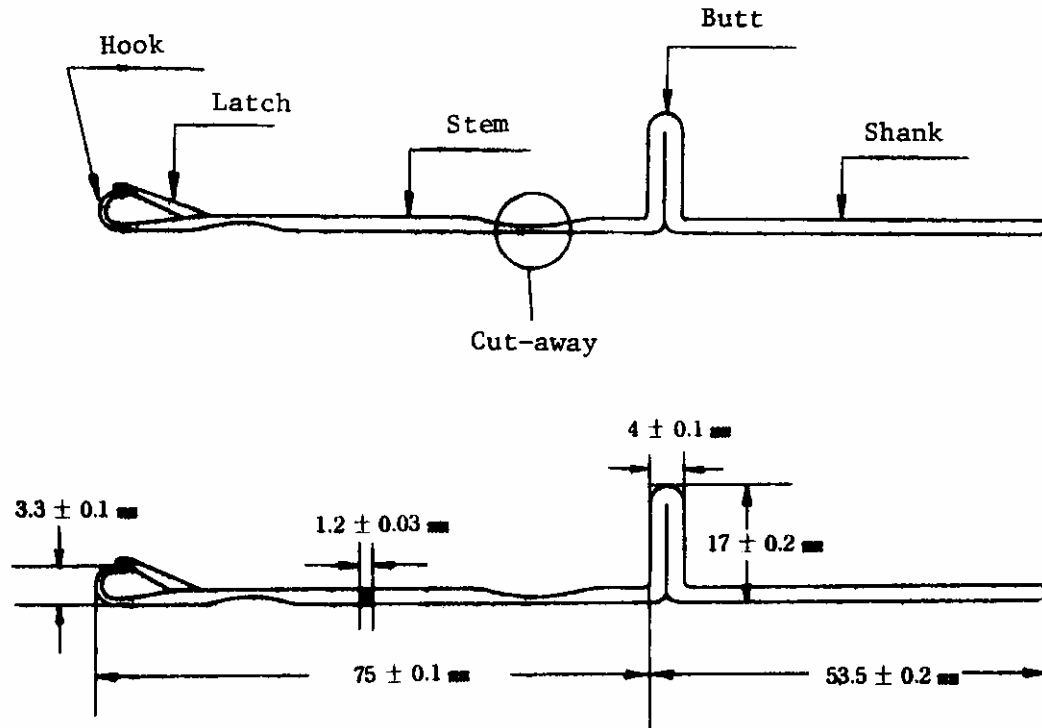

Different from latch needles used for Model K747, this latch needle has higher butt and also cut-away portion on a stem. Further, end of a shank is not bent. Be sure that only this latch needle can be used for Model KS787.

[PRINCIPLE OF NEEDLE SELECTION]

MECHANISM OF NEEDLE SELECTION

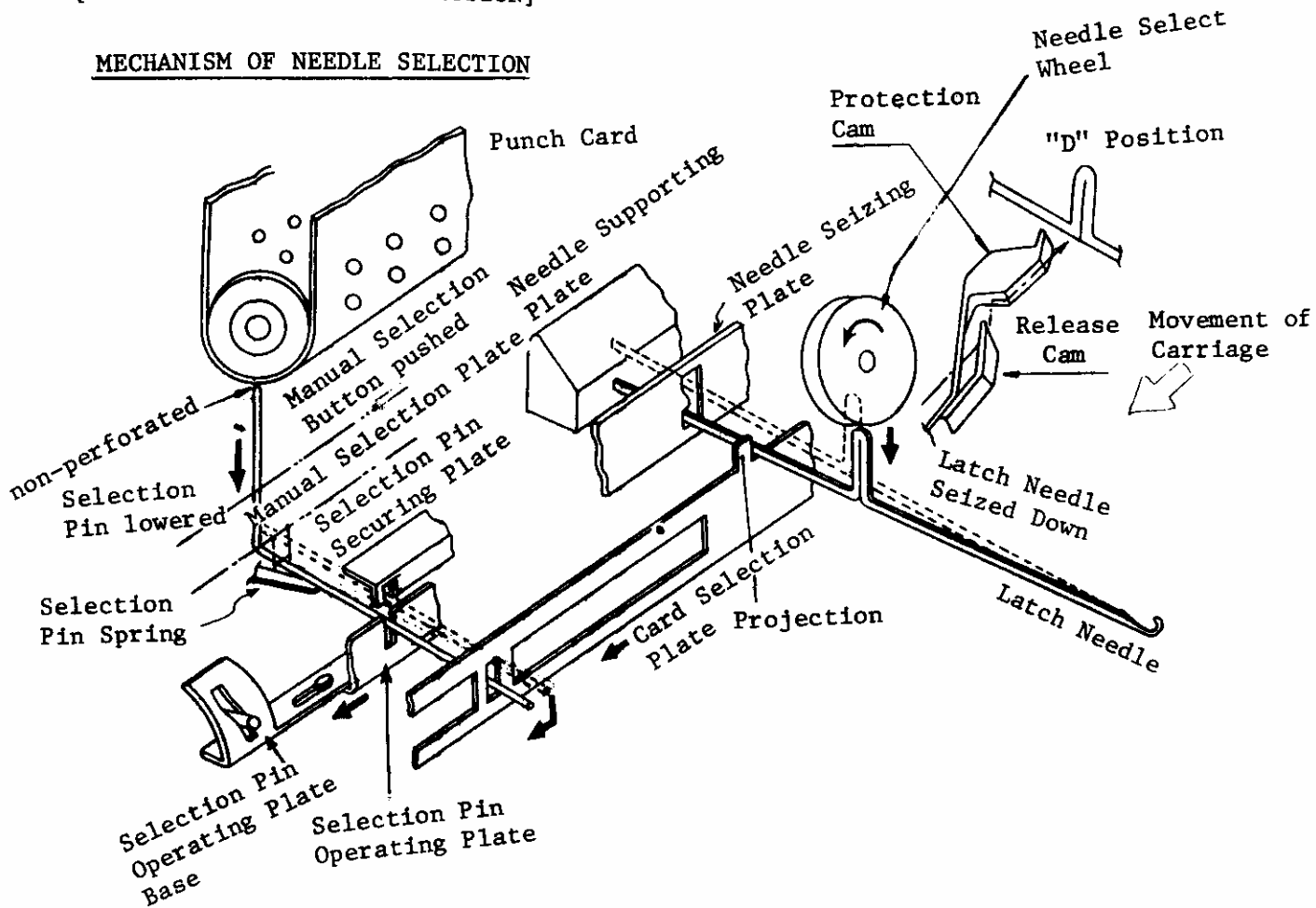

ORDER OF OPERATION

(A) Operating Parts	Punch Card (Manual Selection Button)	Selection Pin	Selection Pin Securing Plate	Selection Pin Operating Plate Base
(B) Operation	non-perforated (pushed)	lowered	disengage selection pin	engage and move selection pin

Card Selection Plate	Needle Select Wheel	Needle Seizing Plate	Protection Cam (Carriage)
moved	Push needle downward	Keep needle lowered	Select needle and push to "D" position

NON NEEDLE SELECTION

"B" position

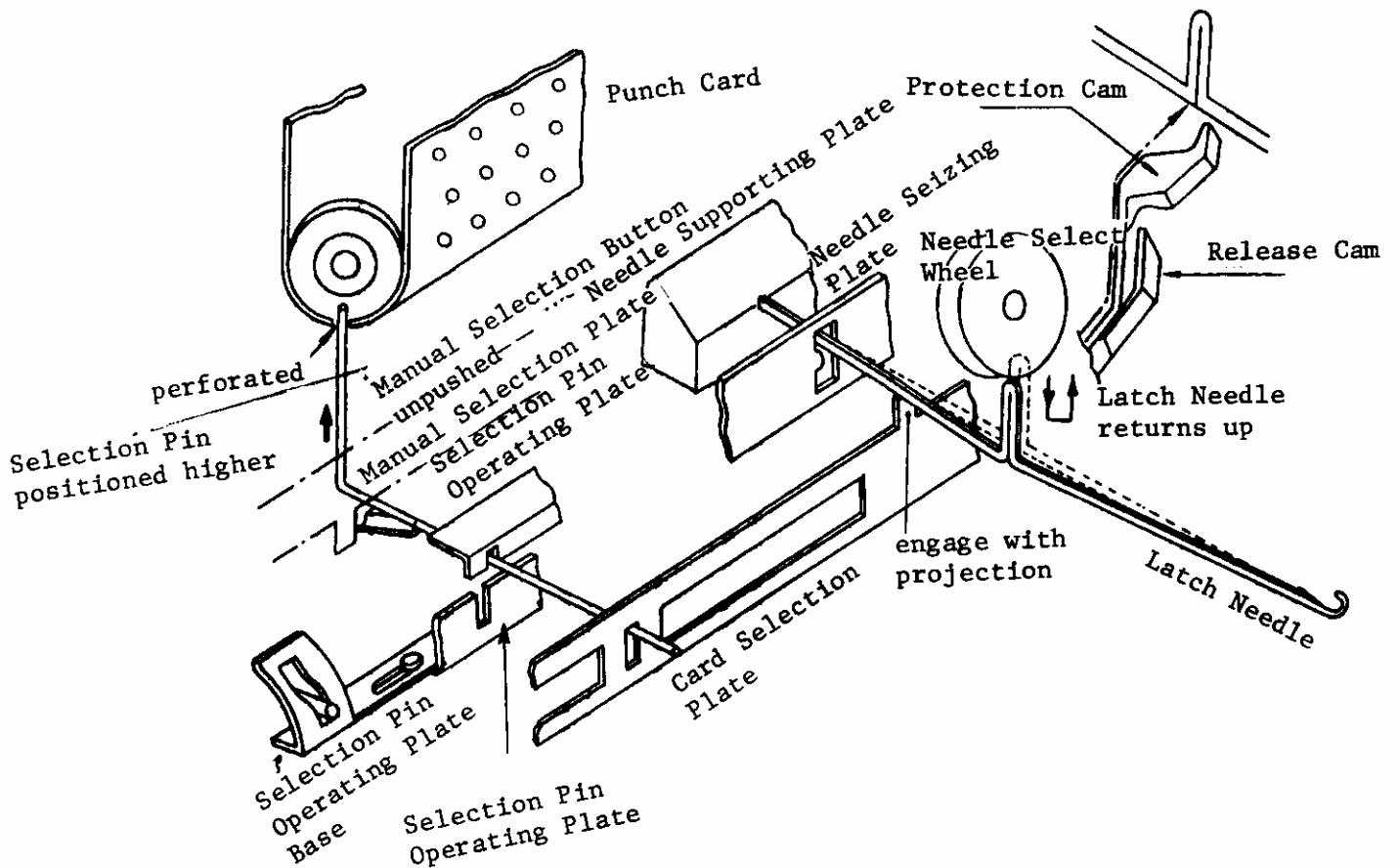

ORDER OF OPERATION

(A) Operating Parts	Punch Card (Manual Selection Button)	Selection Pin	Selection Pin Securing Plate	Selection Pin Operating Plate Base
(B) Operation	perforated (unpushed)	Kept higher	engage selection pin	disengage selection pin

Card Selection Plate	Needle Select Wheel	Needle Seizing Plate	Protection Cam (Carriage)
fixed	Needle engages with projection and not go down	can not seize needle down	needle unselected and kept "B" position

Fig. 1

1 Punch Card Selection

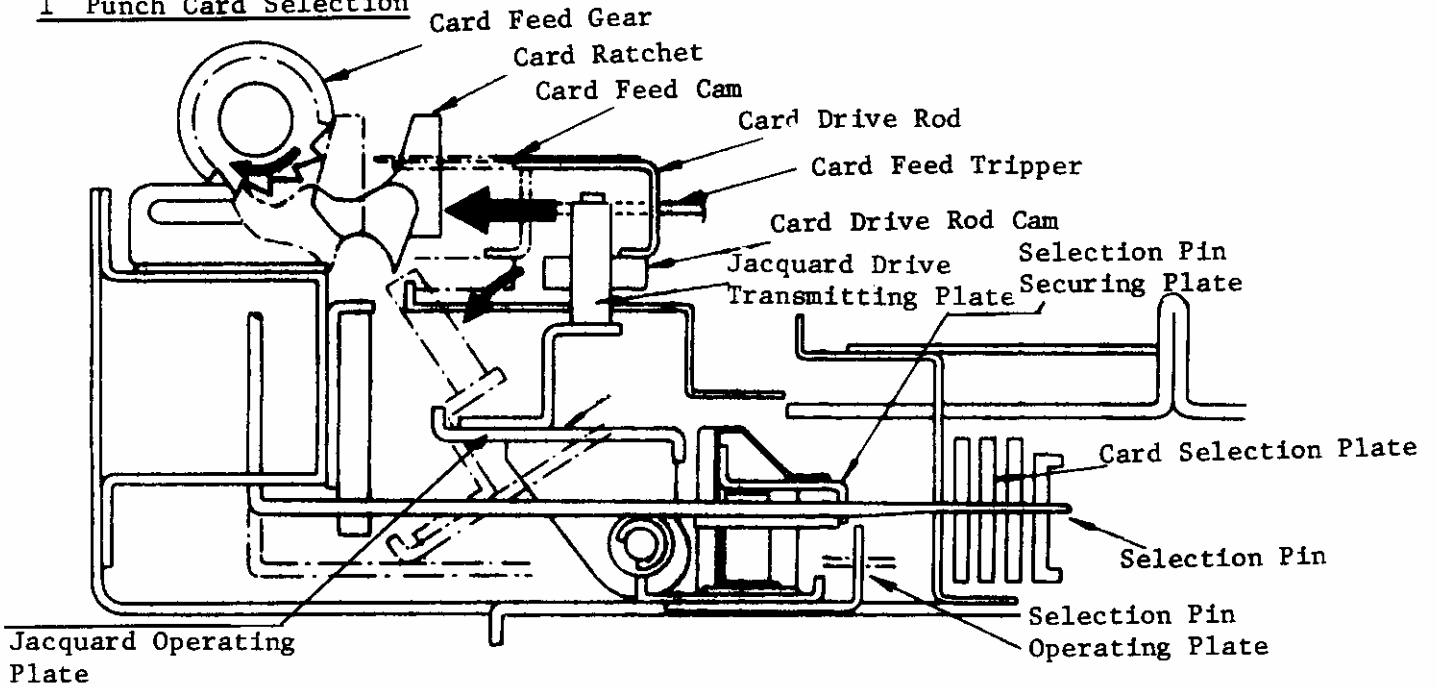

(See Fig. 1)

1. Set punch card and drive main carriage.
2. Card feed tripper rotates card drive rod, and card drive rod rotates jacquard operating plate to dotted-lined position through card drive rod cam.
3. Selection pin operating plate fixed to selection pin operating plate base is moved by jacquard operating plate which is mounted upon cam portion of selection pin operating plate base.
4. Operation of selection pin operating plate keeps selection pin downward apart from perforation of punch card, and then feed punch card by rotating card feed gear by one pitch through card feed cam and card ratchet.

Fig. 2

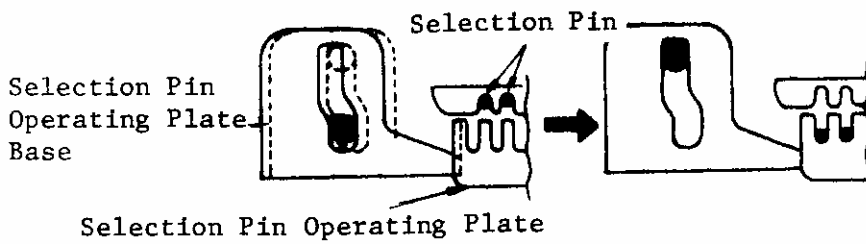
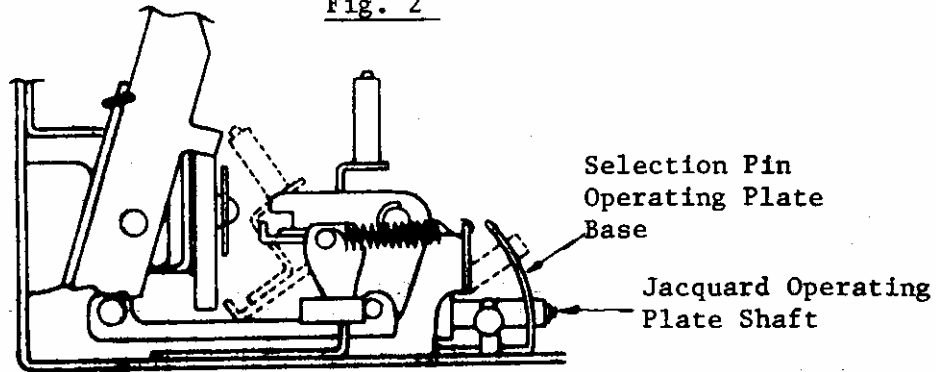

Fig. 3

(See Fig. 2)

5. Selection pin operating plate base and selection pin operating plate are moved by rotation of Jacquard operating plate.

(See Fig. 3)

6. Grooves of both selection pin securing plate and selection pin operating plate corresponds each other.
7. Selection pins are urged lowered into grooves of selection pin operating plate by jacquard operating plate.

Fig. 4

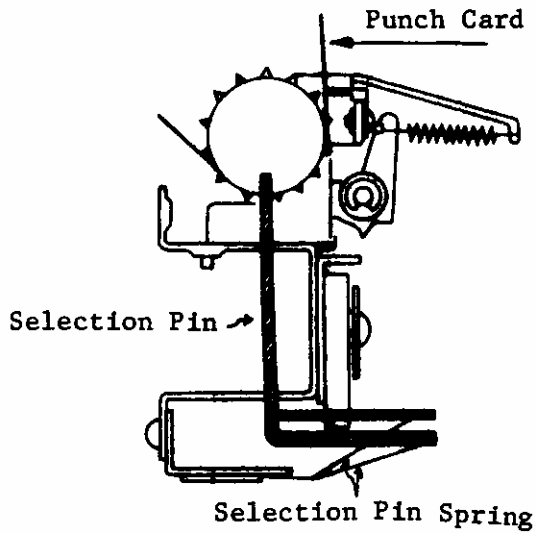

Fig. 5

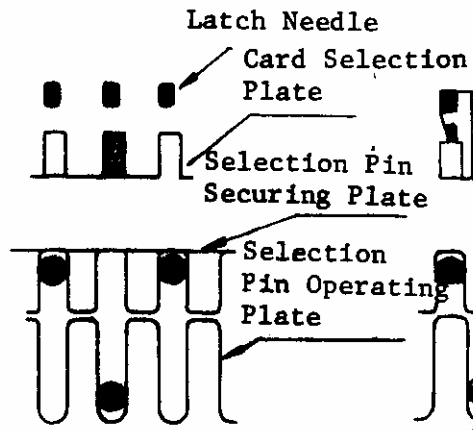
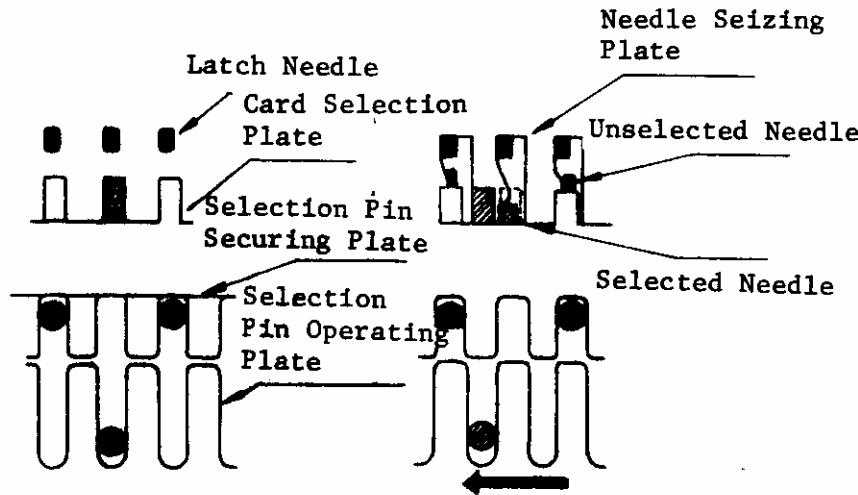

Fig. 6



(See Fig. 4)

8. Upon card feed tripper rotating to opposite direction to the movement of carriage, card drive rod returns to its original position.

(See Fig. 5)

9. Upper end of selection pin which corresponds to non-purforated portion of punch card stops at the position indicated in oblique lines in Fig. 4, and selection pin which corresponds to the perforation of punch card is raised higher through the perforation indicated in smeared.

(See Fig. 6)

10. Selection pins remain in grooves of selection pin operating plate is moved horizontally to arrow-indicated direction by return movement of jacquard operating plate and selection pin operating plate base.

Fig. 7

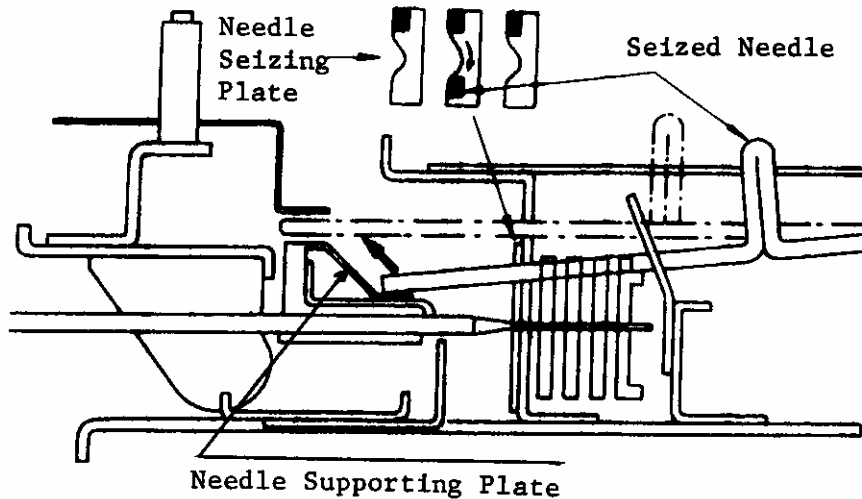

(See Fig. 7)

11. Needle select wheel of carriage located rearward to the direction of carriage movement pushes down butt of latch needles.
12. Latch needles which do not correspond to projection of card selection plate are lowered and seized by shoulder of needle seizing plate.
13. Latch needles stopped by the projection of the card selection plate remain higher position and are moved to "B" position (unselected position).
14. Latch needles seized by the shoulder of the needle seizing plate are passed through protection cam and moved in arrow direction by release cam. And, then the needles are raised up apart from the shoulder of the needle seizing plate by slant surface of needle supporting plate and positioned at "D" (selected position).



2 MANUAL BUTTON SELECTION

Fig. 1

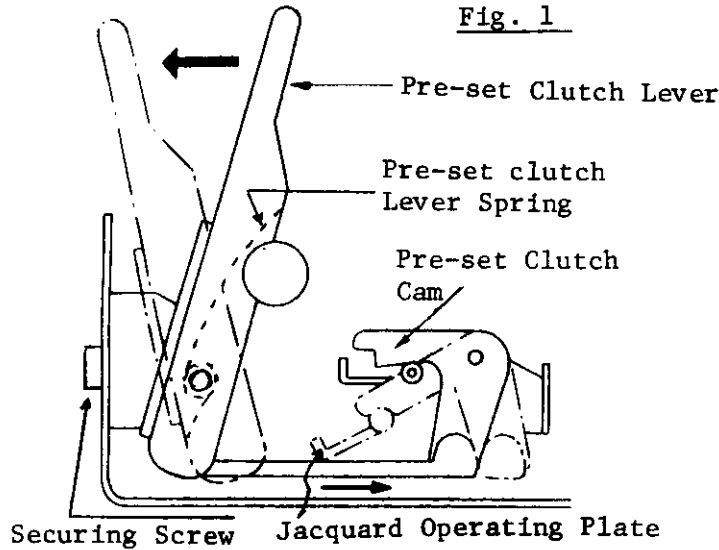
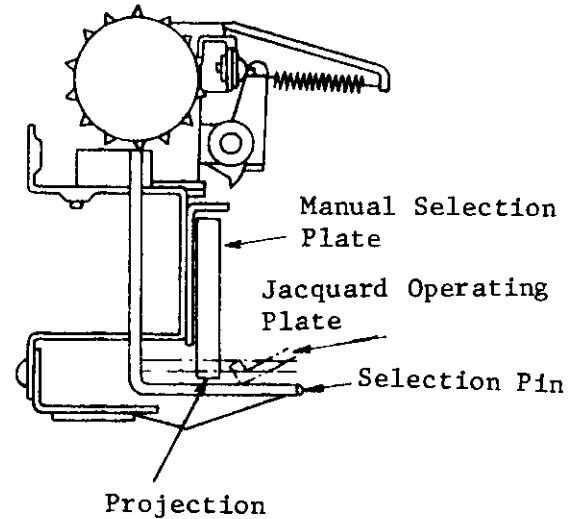

Fig. 2



(See Fig. 1)

1. Push pre-set clutch lever to arrow direction (position "▲").
2. Jacquard operating plate is moved back to the position indicated in dot and dash line through pre-set clutch cam.

(See Fig. 2)

3. Selection pins are lowered to the position apart from projections of manual selection plates by jacquard operating plate.

Fig. 3

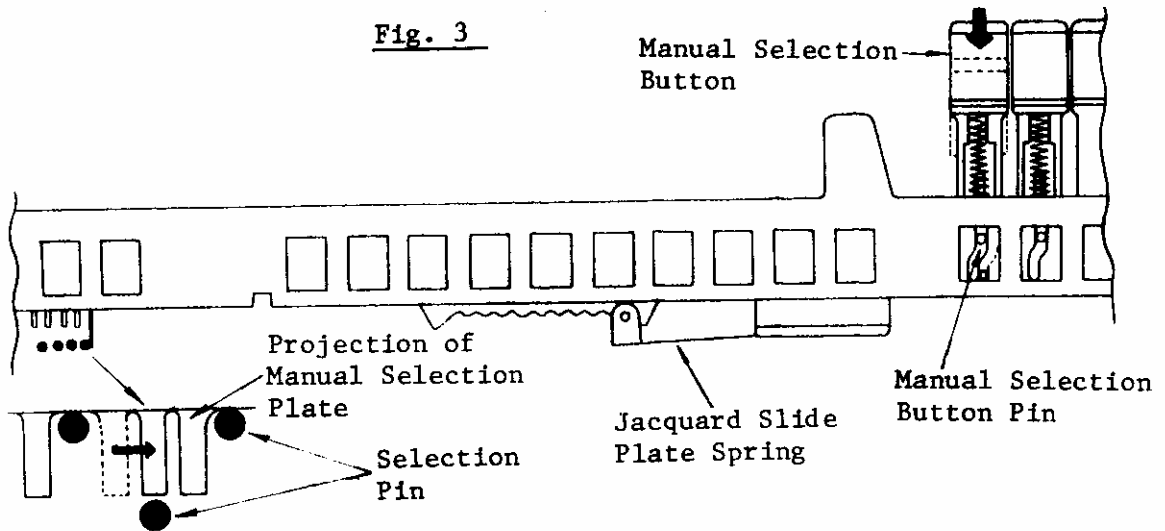

(See Fig. 3)

4. While the pre-set clutch lever being pushed to set position (Position "▲"), push manual selection button.
5. Manual selection plate which has in its groove manual selection button pin of the pushed manual selection button moves to rightward due to shape of the groove, and projection of the moved manual selection plate comes to positioned just on any selection pin.
6. Upon the pre-set clutch lever being released, jacquard operating plate returns to its original position.

7. Then, selection pin below the projection<sup>of</sup> the selected manual selection plate is stopped and kept lowered by the projection. And, selection pins below the unselected manual selection plates are raised into grooves of the manual selection plates.
8. The raised selection pins are hold in the grooves of selection pin securing plate.
9. Lowered selection pins are caught by the grooves of selection pin operating plate and moved to left-ward, thereby selecting any card selection plates to perform needle selection.

### 3 ZIGZAG DIAL

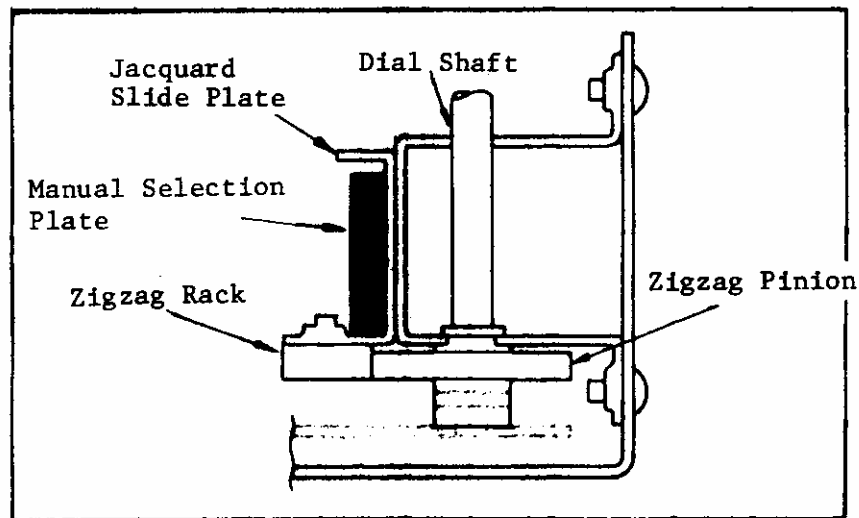

1. Rotate zigzag dial and operate zigzag rack which is geared with zigzag pinion.
2. Manual selection plates are slided(or zigzagged)by jacquard slide plate which is integral with the zigzag rack.

(Notice)

When zigzag dial and manual selection buttons are to be operated, pre-set clutch lever must be pushed to position "▲". Otherwise, manual selection plates can not be operated because selection pins are mounted inside the grooves of the manual selection buttons.

4 AUTO MOTIF SELECTION

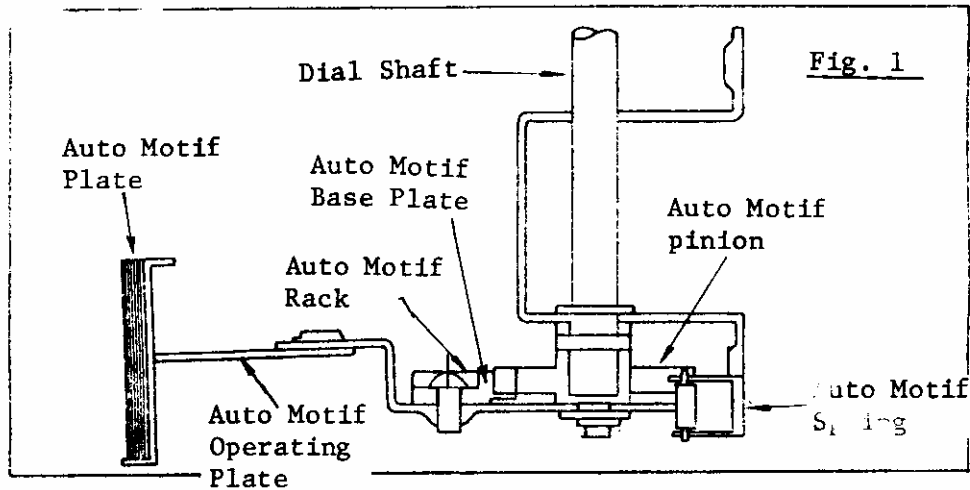

(See Fig. 1)

1. Rotate auto motif dial and operate auto motif rack which is geared with auto motif pinion.
2. Auto motif plate is moved by auto motif operating plate which is integral with auto motif rack.

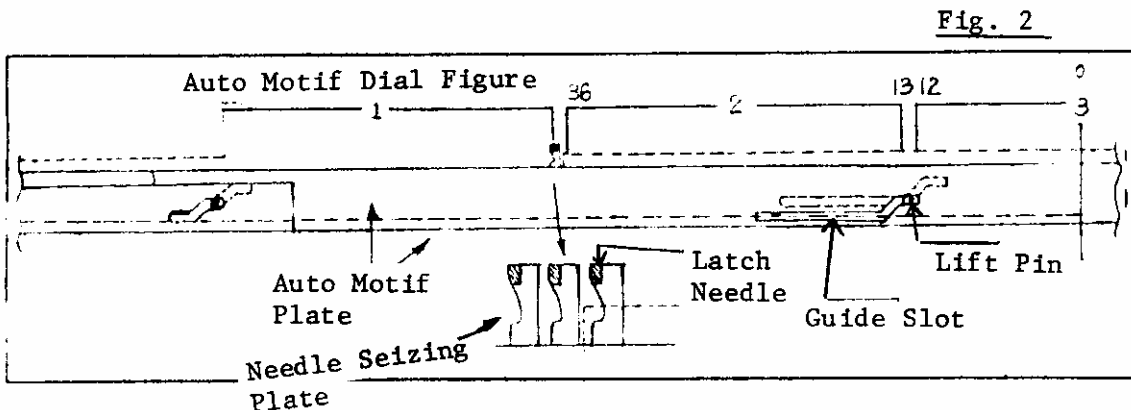

(See Fig. 2)

3. Selection of auto motif plate is made being raised by lift pin which is fixed to guide groove of auto motif plate
4. In case that the dial is set at "1", the related auto motif plate has dent portion between 60th and 37th needles at the left side of needle bed, and this dent permits needle seizing operation of needle seizing plate, thereby performing needle selection between the above stitches.
5. The latch needles beside the above stitches are stopped by upper surface of the auto motif plate and can not be lowered for being seized by needle seizing plate and, therefore, all these needles can not be selected.
6. 5 kinds of auto motif plates are shifted respectively in accordance with each positioning pitch of auto motif base plate.

[PRINCIPLE OF KNITTING]

1 PLAIN KNITTING

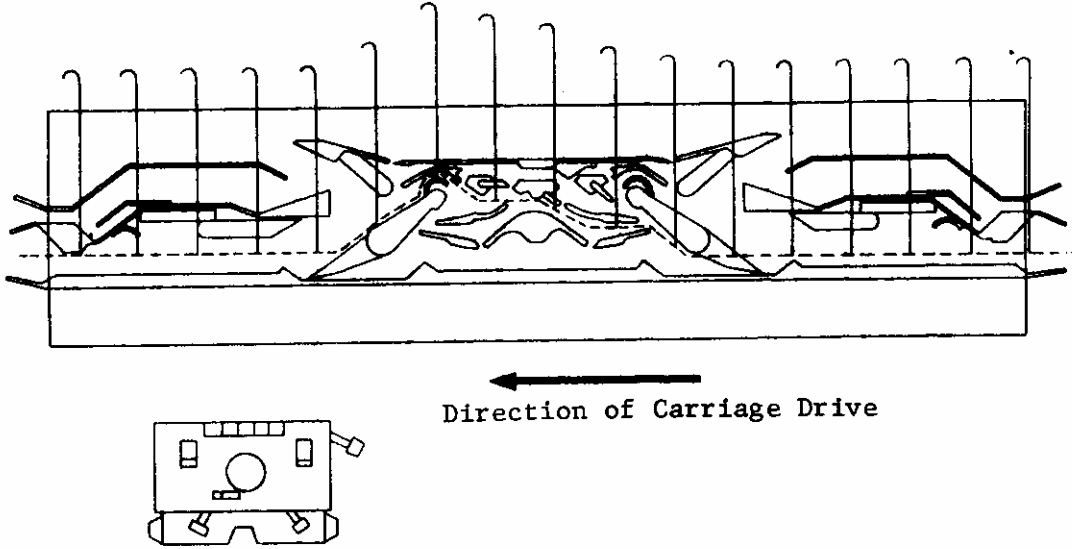

2 TUCK STITCH KNITTING

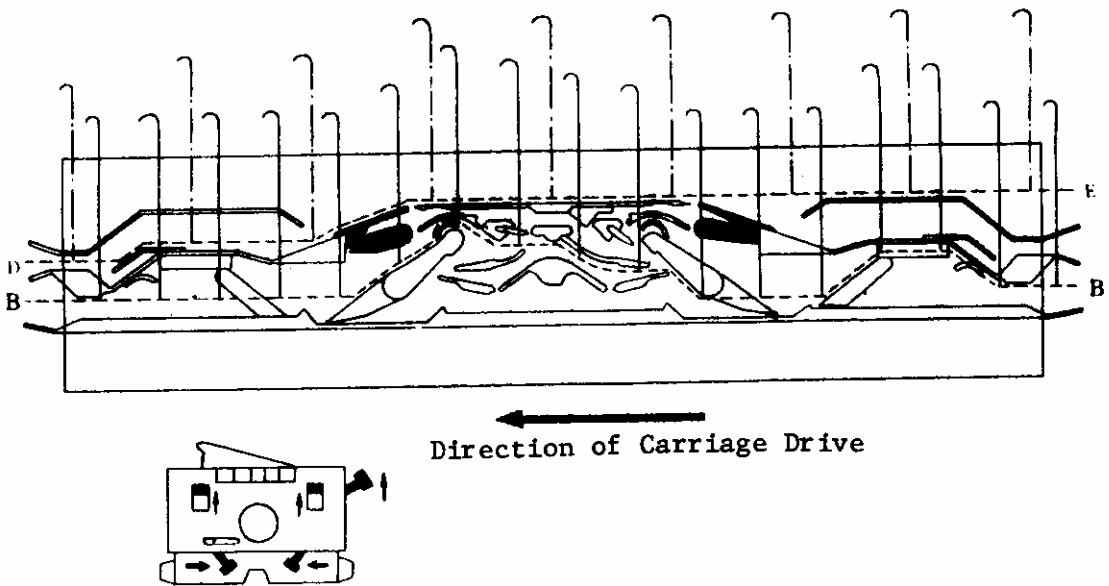

### 3 FAIR ISLE KNITTING

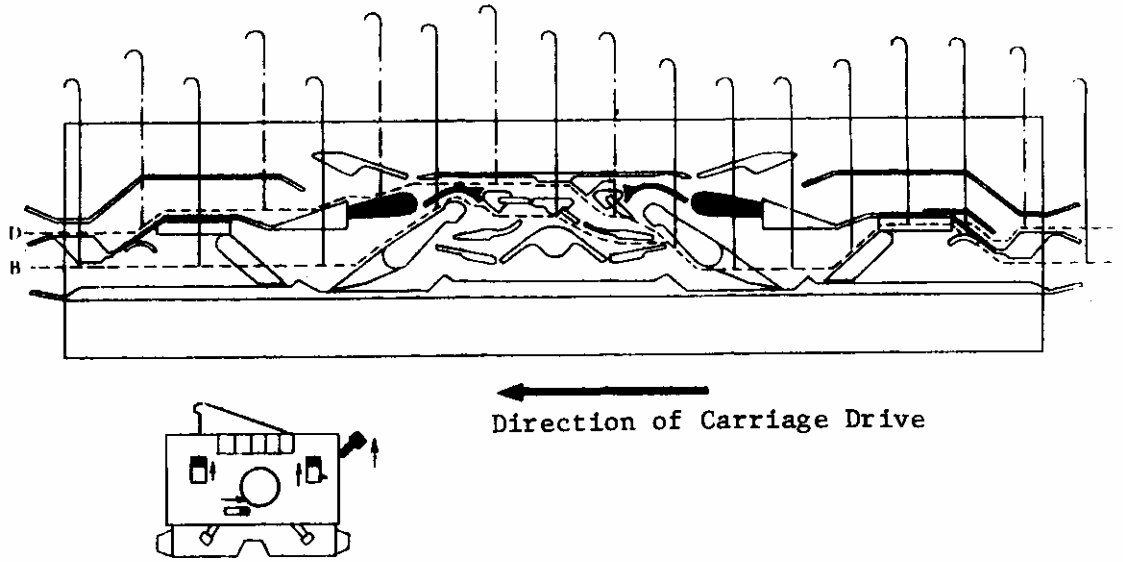

### 4 TUCK PATTERN KNITTING

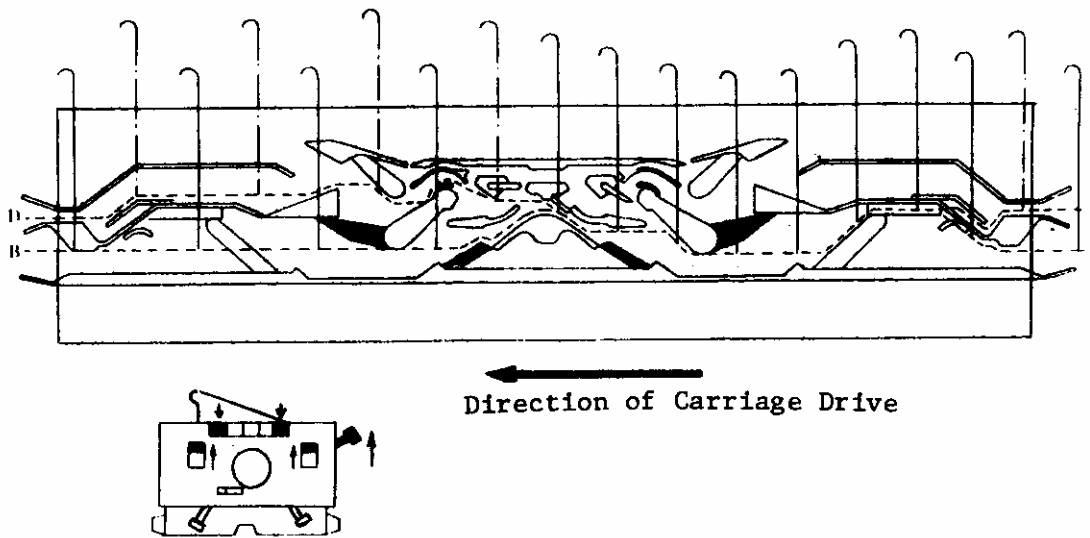

5 SLIP LOOP KNITTING

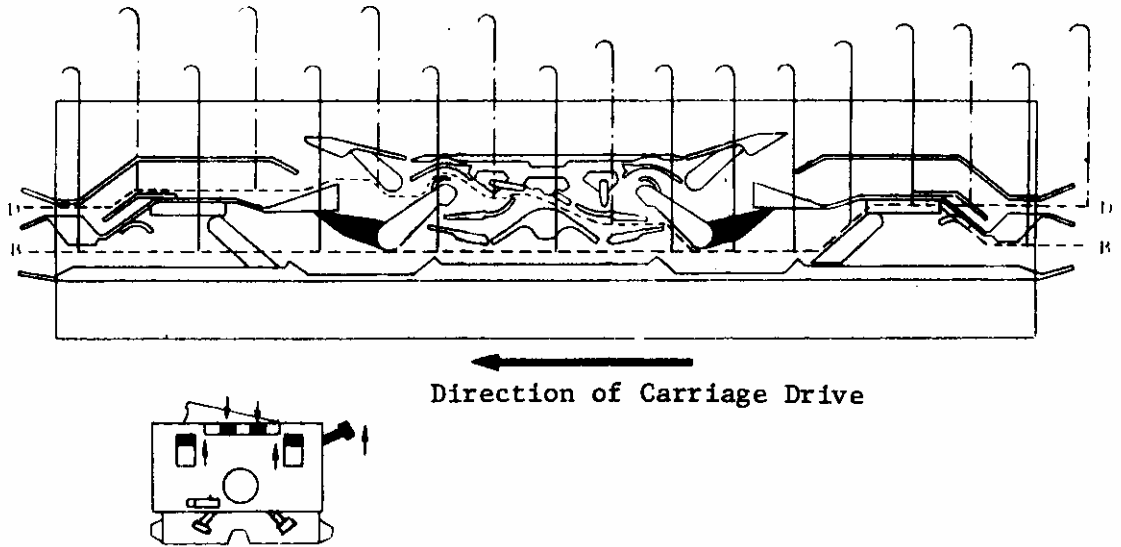

6 PARTIAL KNITTING OF PLAIN STITCH

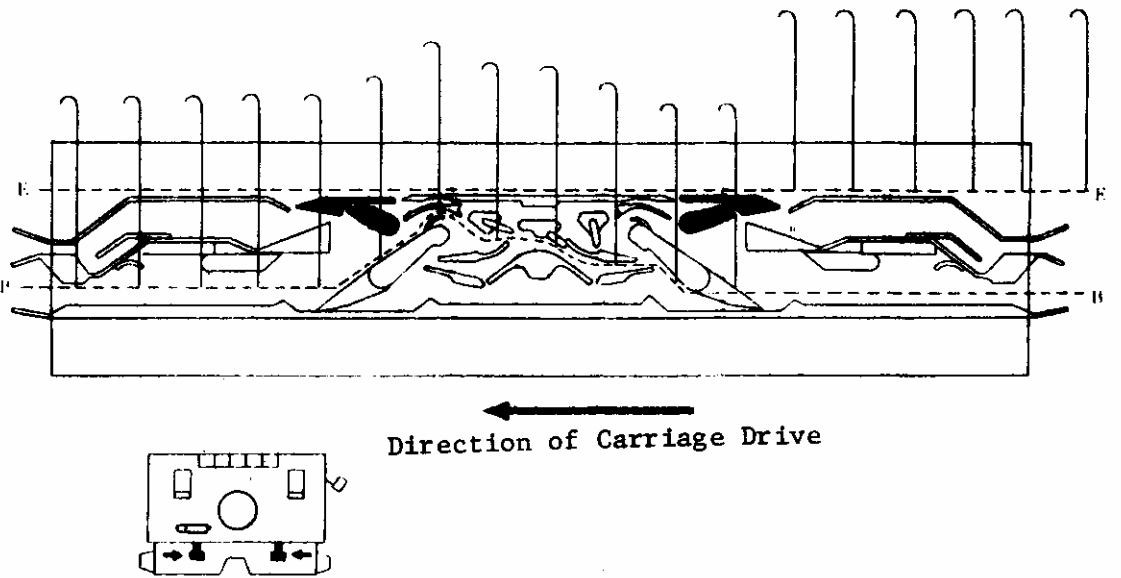

### Replacement Procedure of Selection Pin

In case the selection pin is deformed or damaged, replace it in accordance with the following steps.

#### Disassembling Procedure

1. Take out needle bed from lower case and remove card drive, rod and panel plate.
2. Take off fixing screws for needle bed base (1) (2) and needle supporter (2)
3. Take off fixing screws for needle supporting plate stopper and take out needle supporting plate stopper.
4. Take out needle bed from needle bed base plate (1) (2)
5. Take off fixing screws and springs from Jacquard Operating Plate, needle supporting plate (1) and selection pin securing plate
6. Put a marking on Jacquard base plate so that right position of the parts can be identified, then take off fixing screws for needle bed base plate (1) and Jacquard base plate, and take out needle bed base plate (1) and Jacquard base plate.

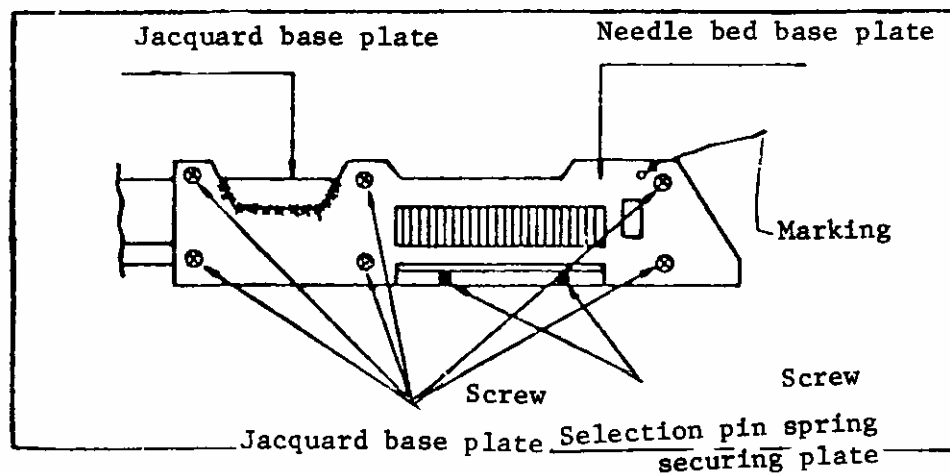
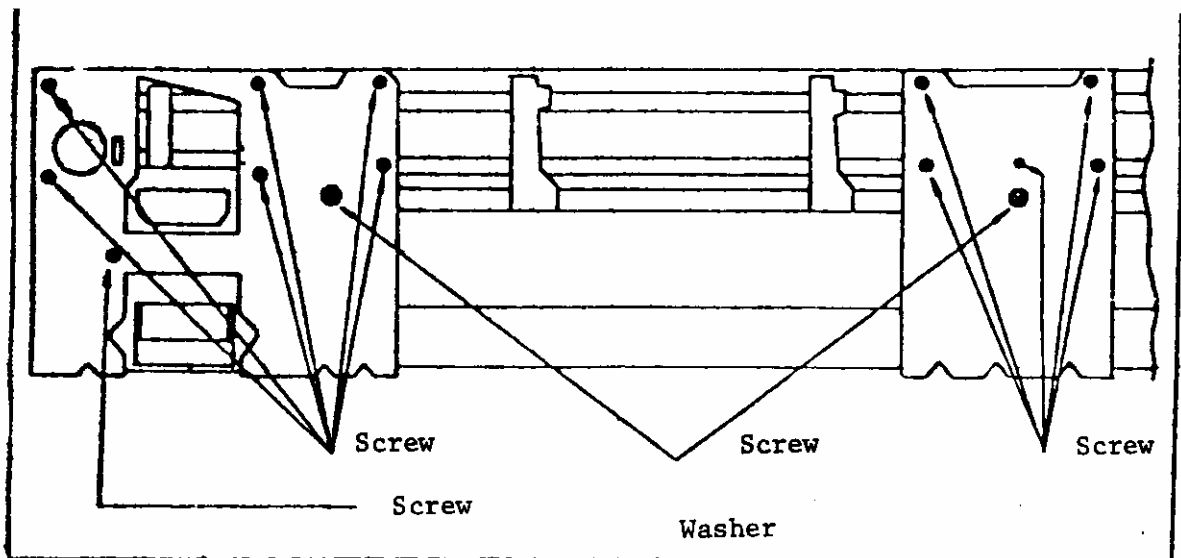

7. Take off fixing screws for selection pin spring securing plate and take out selection pin spring securing plate.
8. Take out selection pins from jacquard base plate.

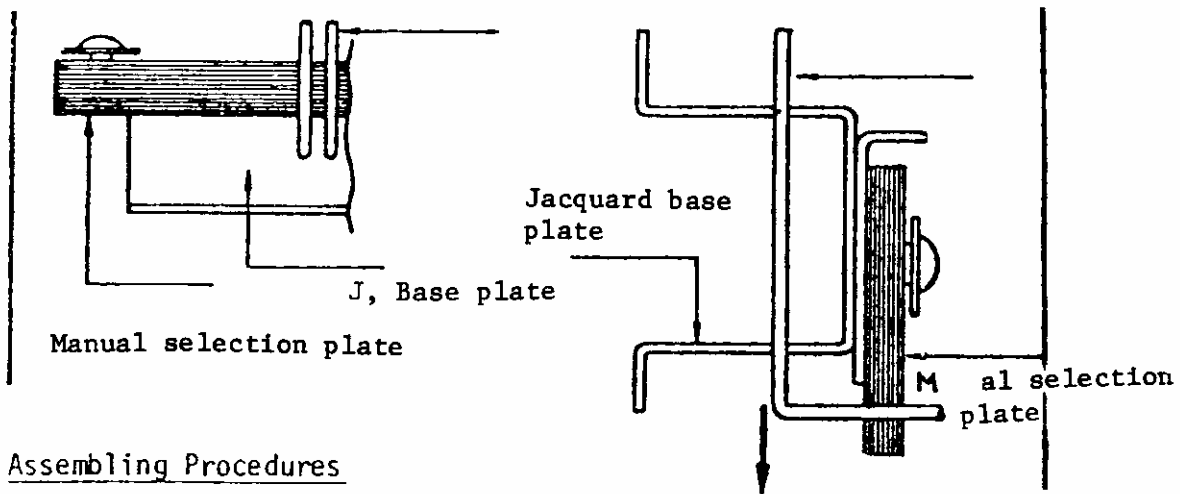

### Assembling Procedures

1. Put selection pins into corresponding holes of Jacquard base plate.
2. Assembling Jacquard base plate to needle bed base plate
  - a) Put selection pins into cut part of the comb of selection pin operating plate.
  - b) Adjust the position of Jacquard base plate from needle bed base plate making the height  $44.0 \pm 0.2\text{mm}$  and assemble it.
  - c) Alternatively attach needle bed base plate to Jacquard base plate according to the marking on Jacquard base plate suggested in previous page.

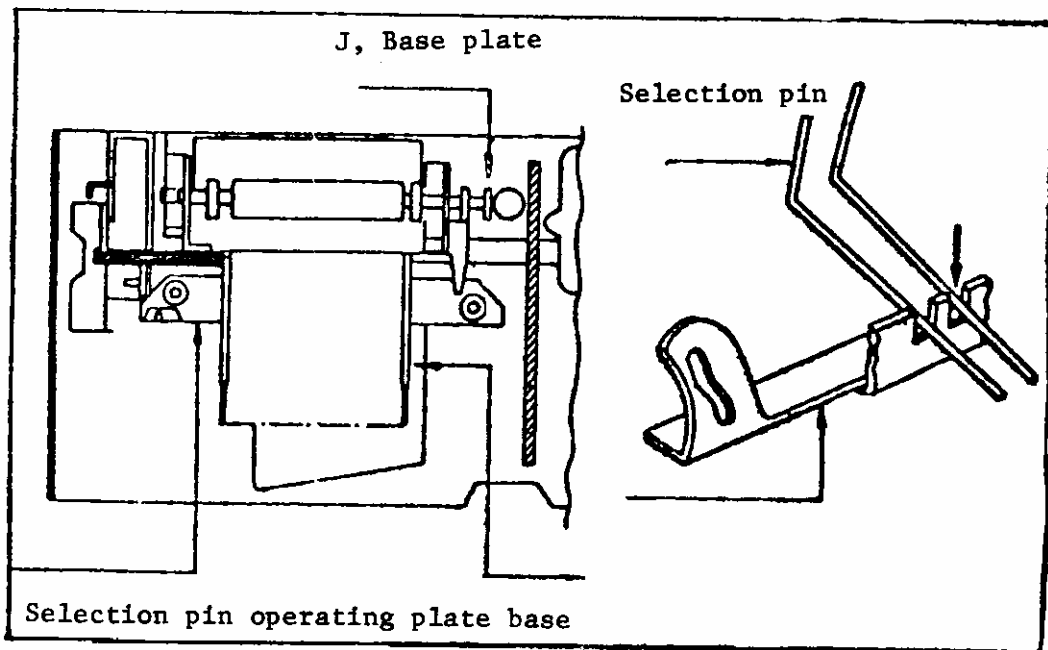



3. Assembling selection pin securing plate

Please refer to explanation about adjustment of selection pin securing plate

4. Assembling needle supporting plate (1)

Put projection of selection pin securing plate at left hand side into rectangular hole of needle supporting plate (1) and tighten fixing screw at right hand side.

In this procedure please note that needle supporting plate (1) should be assembled so that projection of needle supporting plate (2) can be located behind needle supporting plate (1).

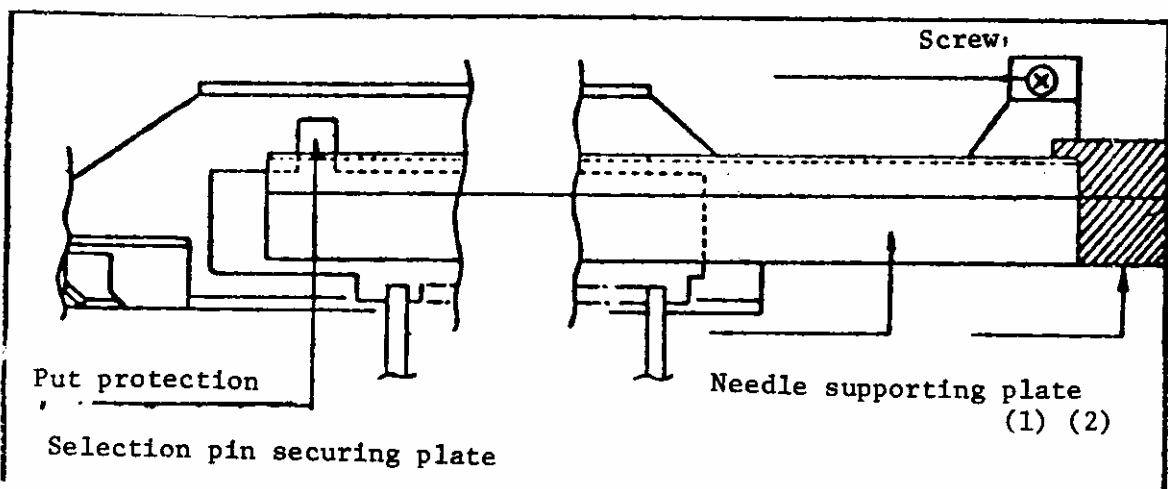

5. Assembling Jacquard operating plate

Please refer to explanation about adjustment of Jacquard Operating Plate.

6. Assembling selection pin spring securing plate

Attach securing plate to Jacquard base plate

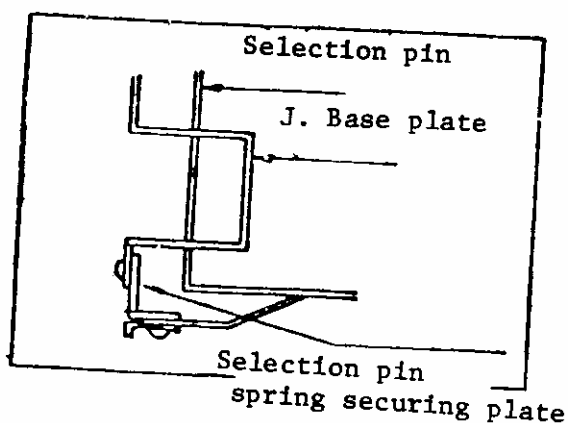

Selection pin spring should be imposed upon in the center of selection pin as illustrated in the right figure and should not be disengaged even when the pin is moved to arrow direction by the operation of pre-set clutch lever

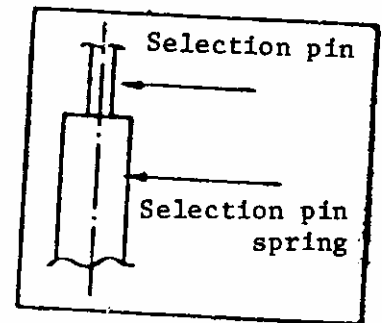

7. Assembling needle bed to needle bed base plates

- a) Slide all card selection plate to left (all cut position bottom left side on card selection plate should be in line as illustrated.)
- b) Holding Jacquard base plate insert each selection pin into corresponding slot of selection plate from the centre part of pins. Refer to the illustration.

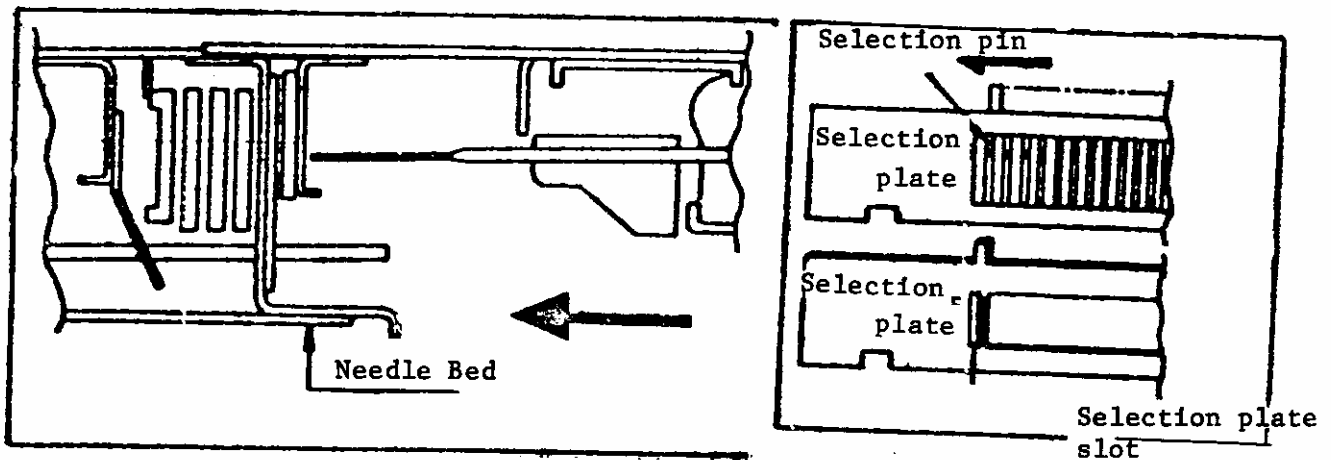

- c) Slide all Auto Motif Plates to right and make positioning hole on the plates corresponding to the positioning hole on needle bed back plate, then set Auto Motif Dial to "5"

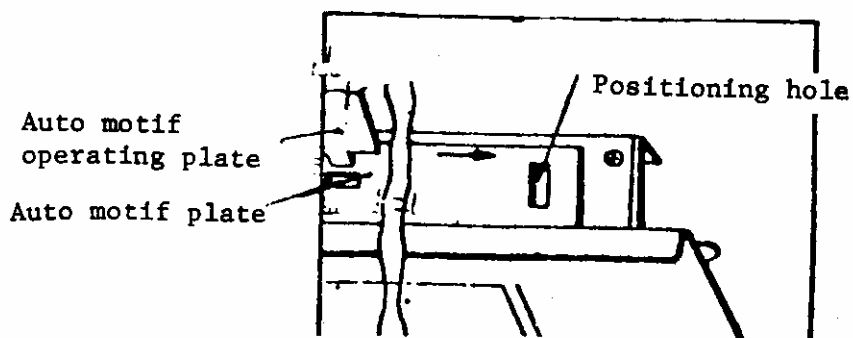

- d) Insert projection of Auto Motif operating plate into setting slot of Auto Motif Plates.
- e) Fix set screws of Needle bed base plate (1) (2) and needle supporting plate. For adjustment please refer to the explanation about adjusting needle bed base plate position.

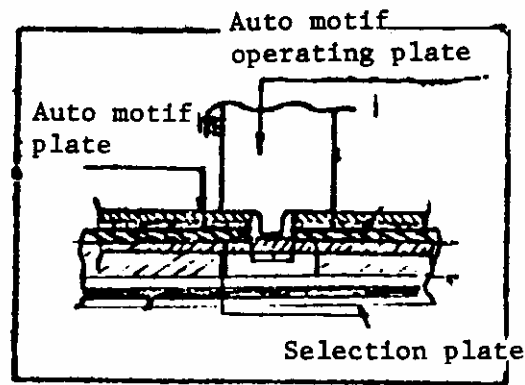

8. Assembling needle supporting plate stopper

Place needle supporting plate stopper on needle bed base plate as the illustration, and fix set screw pressing point of the stopper against needle supporting plate (1)

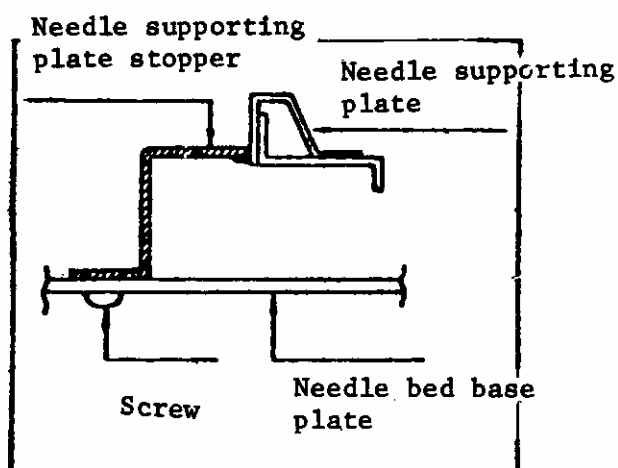

- 9. Check assembling of all the parts related to needle selection by sliding carriage and make sure that needle selection can be done in correct manner. Then assemble needle bed to lower case

## Adjustment of Needle Bed Position

### Checking

Check if rectangular positioning hole of needle bed base plate (1) corresponds to cut away position of needle bed back plate within 0.1mm by eye sight.

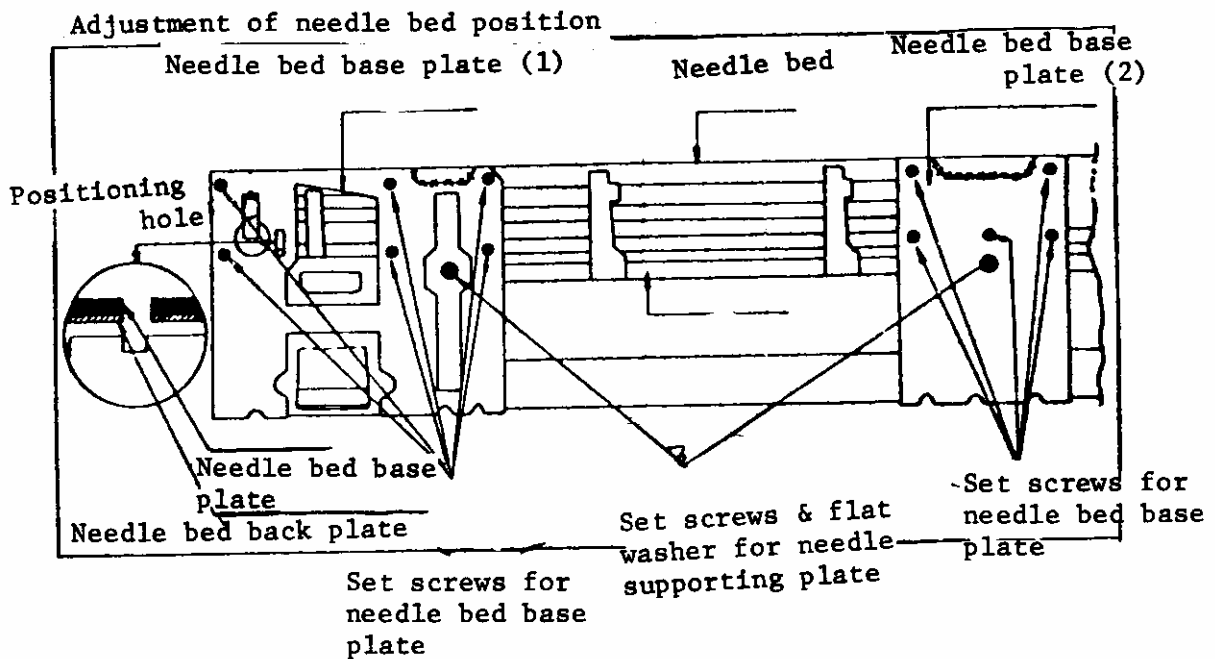

### Adjustment

1. Loosen set screws of needle bed base plate (1) (2) and set screws of needle supporting plate (2). Adjust the position of needle bed base plate (1) and (2), and tighten set screws making rectangular positioning hole correspond to cut away position of needle bar back plate.

When the position of needle bed base plates are adjusted, make sure these plates locate at right position not only sideways but also back and front. It is advised to put a marking on needle bed back plate and sinker comb holding plate by using sharp screw-driver before loosening set screws of needle bed base plate. When these plates are assembled, place the parts at marked position.

2. The distance between needle bed base plate and needle bed can be adjusted by making the distance between needle bed back rail and card drive rod front at  $18.0 \pm 0.2$  mm

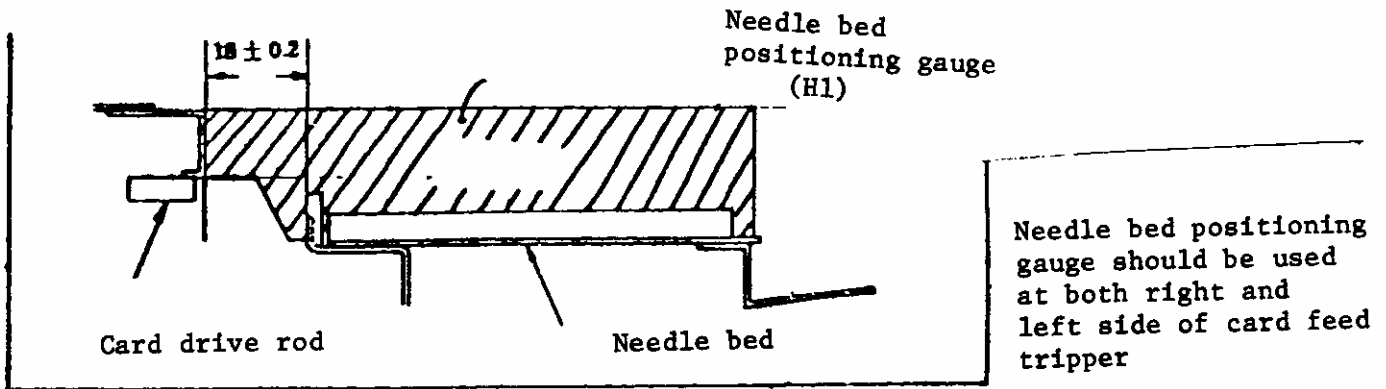

- a) When the distance is far from the above the following problem will be experienced.
- \* Card feed tripper of carriage couldn't push card drive rod enough and this cause card feeding problem.
  - \* Auto Motif Plates don't work properly even if auto motif dial is set.
- b) When the distance is closer than the above, the following problem will be experienced.
- \* Selection pins would hit against needle supporting plate and this does interfere with smooth up and down movement of selection pins.
  - \* This would make turning of Auto Motif Dial heavy
  - \* Card feed tripper of carriage can't turn its direction and this makes carriage movement stop.

#### Adjustment

According to the marking mentioned above, adjust the position of needle bar base plate at correct position.

## Replacement of Selection Plate

Disassemble and assemble selection plates according to the following procedure when selection plates are penetrated with oil or deformed.

### (Disassembling Procudure)

1. Take out needle bed complete from lower case.
2. Take out needle bed from needle bed base plate (1) (2).
3. Make marking on needle guide plate in line with side surface of needle bed connecting plates (1) (2) (3) (indicated by "x" in the drawing) and take out oil shutting mat.
4. Loosen 4 screws on needle guide plate. Then, tilt and take out the guide plate having the guide plate not to be caught by latch needles.

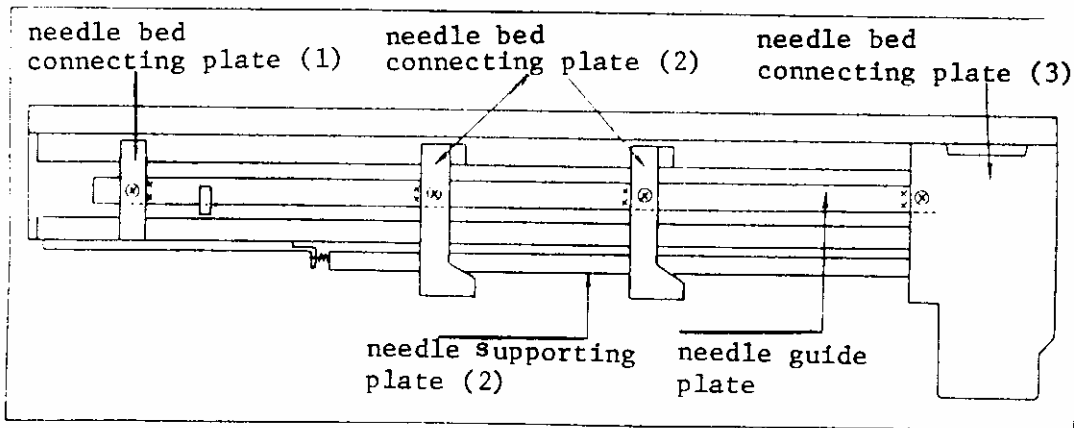

5. Remove E-stop ring and flat washer at 5 positions, and take out selection plates from selection plate set pins. Selection plates (No.1-No.24) are assembled in 3 blocks illustrated in the right drawing.
6. When the selection plates are penetrated with oil, take out all 24 plates and wipe off the oil using gas or bezidine.

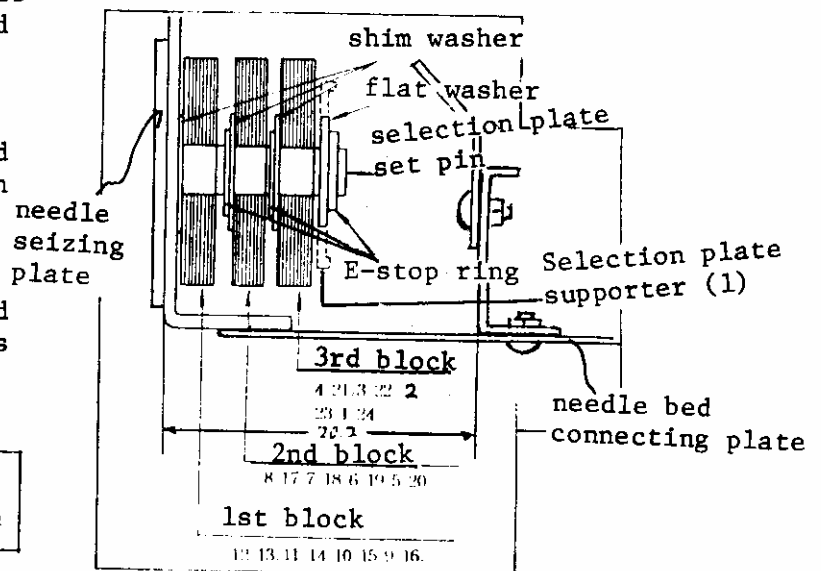

Be careful not to remove needle bed connecting plate

(Assembling procedure)

- (1) Mount a shim washer onto selection plate set pin, then mount the 1st block of selection plates and fix it by E-stop ring. Proceed in the same manner with the 2nd block, and after mounting the 3rd block mount flat washer and E-stop ring. As to end extreme setting pin at selection pin side, mount selection plate supporter (1) instead of flat washer.

Every selection plates should be able to slide lightly under the weight 20 grams

- (2) Assemble needle guide plate to needle bed connecting plates (1) (2) (3) guided by marking on the connecting plates.

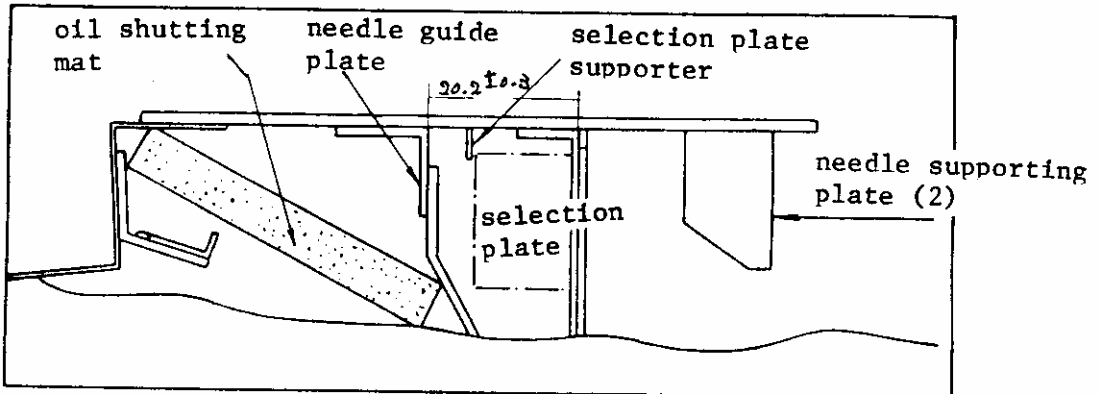

- (3) Needle guide plate should be positioned against center of slot provided on needle bed within eccentricity of 0.1 mm.

Checking :

1. Check if latch needles moves smoothly from "A" to "E" position (Particularly check both extreme-end needles)
  2. Check weight onto latch needle upon being pushed down against shoulder portion of needle seizing plate.
  3. Adjust the position of selection plate.
- (4) Insert oil shutting mat and press it onto needle retaining spring.

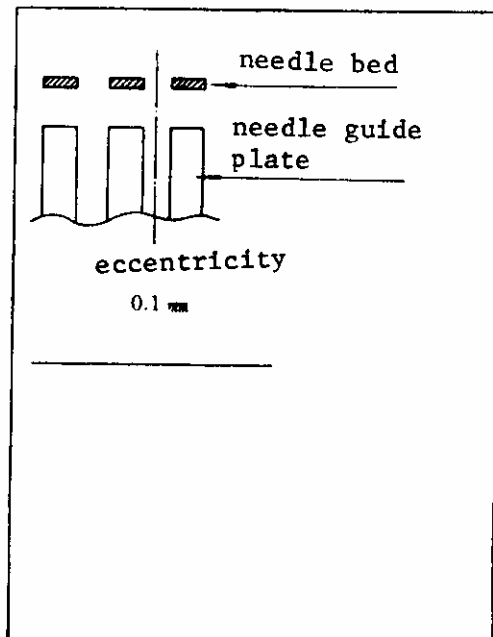

## Replacement Procedure of Manual Plates

Replace manual plates when manual plates were penetrated with oil, or projection of manual plates was broken or deformed.

### (Disassembling Procedure)

- (1) Remove case end, right and left and pattern board (1) (2).
- (2) Remove card drive rod and panel plate
- (3) Take off fixing screws of manual plate and remove washers indicated in the following figure.

Note that 2 kinds of washers are provided at "2" position

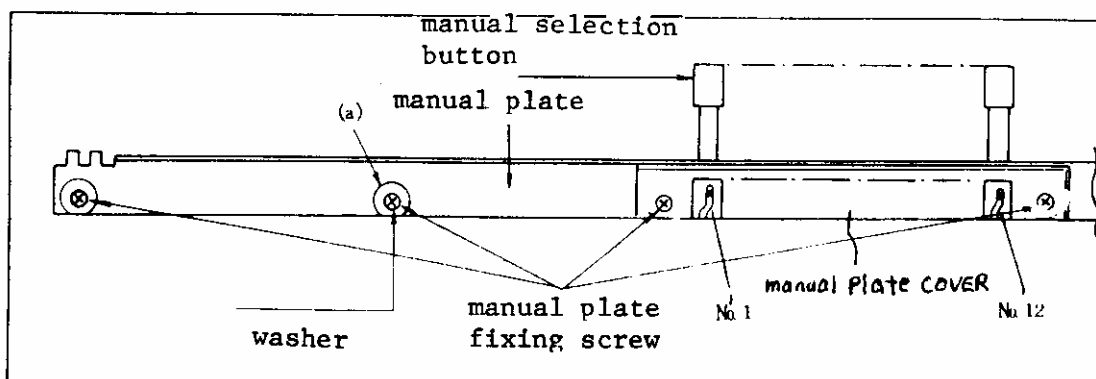

### (Assembling Procedure)

- (1) Manual plates should be assembled to jacquard slide plate in the manner illustrated in the right drawing from No.6-No.12.

### (Sorting of manual plate number)

No. 1 manual selection plate has a slot engaging with manual selection button shaft at left extreme position, and then in order No. 2, 3, 4 ---- to right direction.

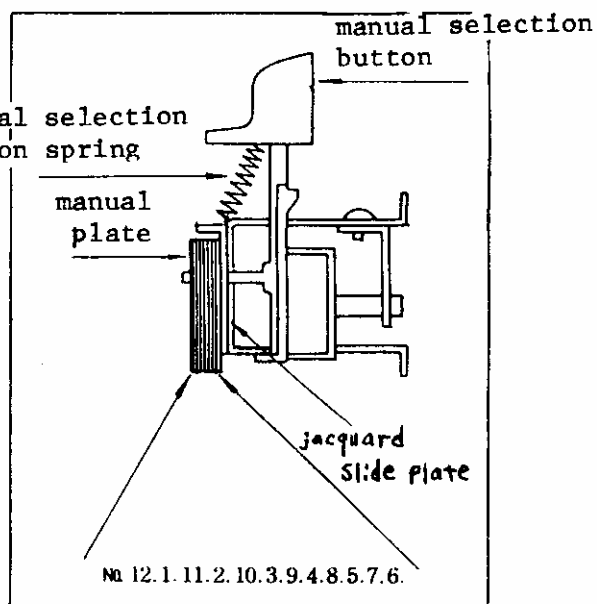



### Adjustment of Manual Plate Position.

Adjust manual plates when manual plates touch upon selection pin due to wrong position of manual plates causing heavy movement of selection pin thereby giving wrong selection both with card and manual selection. But, note that the touch between manual plate and selection pin is also caused by wrong positioning of selection pin securing plate.

### Checking

- (1) Take out needle bed complete from lower case.
- (2) Take off fixing screw for selection pin spring, and remove selection pin spring presser plate and selection pin spring.

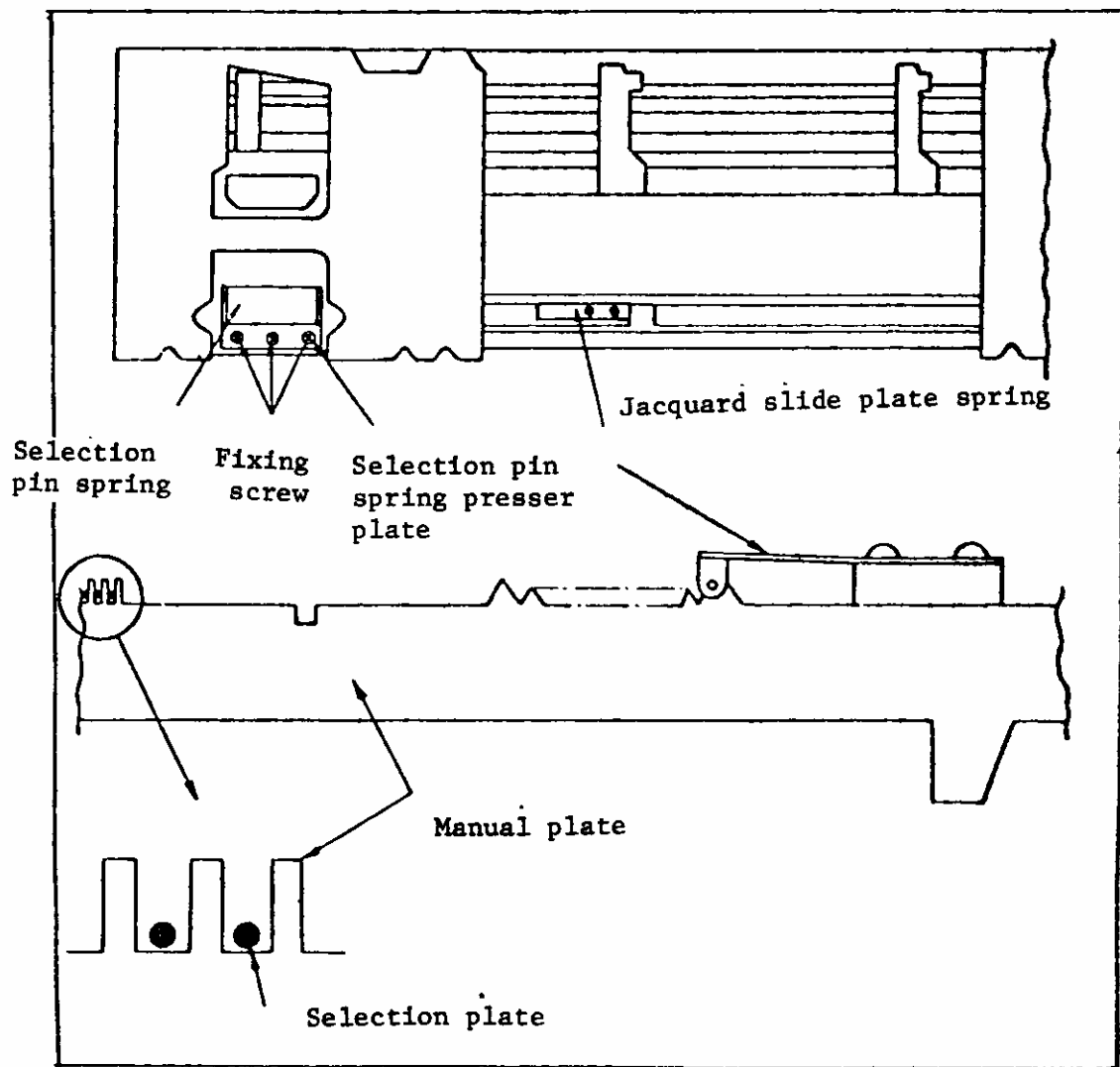

- (3) Check if selection pin and side surface of projection of manual plate are engaged upon the selection pin spring being removed.

Selection pin should not touch side surface of the projection.

#### Adjustment

In case that selection pin touches the side surface of the projection, adjust the position of jacquard slide plate spring that selection pin should be positioned just between projections as illustrated above.

**Positioning of Selection Plates**  
(Adjustment of Selection Pin Securing Plate)

(In case that selection plates are wrong-positioned)

(1) Disassembling procedure

1. Take out needle bed from lower case.
2. Remove card drive rod and panel plate.

(2) Checking

1. Check if square hole provided on back surface of needle bed base plate (1) corresponds to cut-away portion of needle bed.

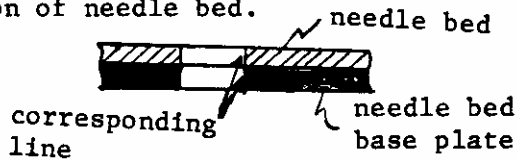

2. Check the position of selection plate in "α" direction at right end of needle bed. (Latch needles must be kept forwarded at "E" position.)

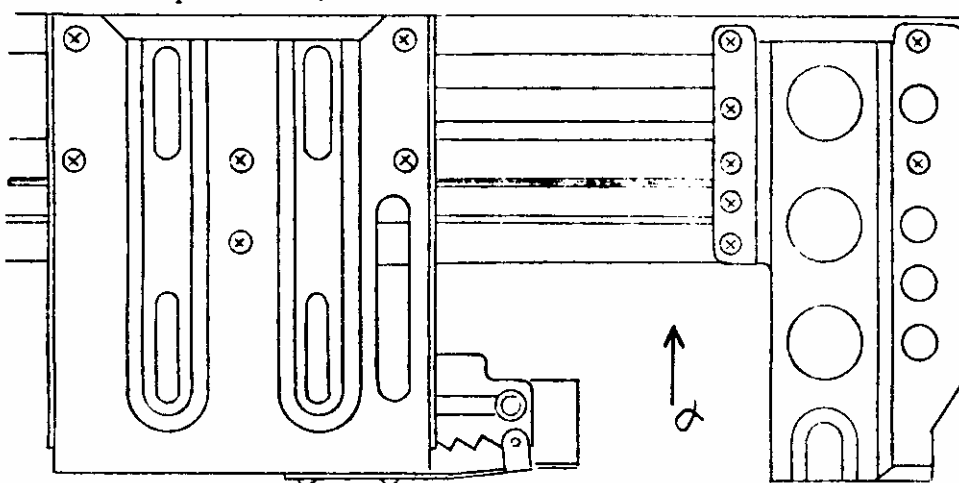

(Checking of set position of selection plate)

In case selection plate correctly-positioned	In case selection plate wrong-positioned	
Latch needle touch upon projection of selection plate when it is pushed	Latch needle goes down lowered because of no engagement with the projection	

\* This checking must be conducted without setting punch card nor manual selection button.

(3) Adjustment

1. Adjust selection pin securing plate in right and left direction by loosening screws for the selection pin securing plate.

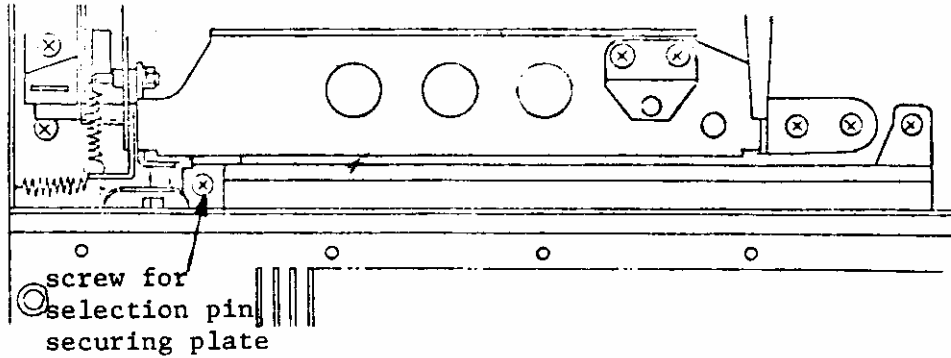

2. Check if selection pin can be lowered smoothly to the direction of selection pin operating plate by operating pre-set clutch lever and if the selection pin can be raised to the direction of selection pin securing plate upon the clutch lever being released.

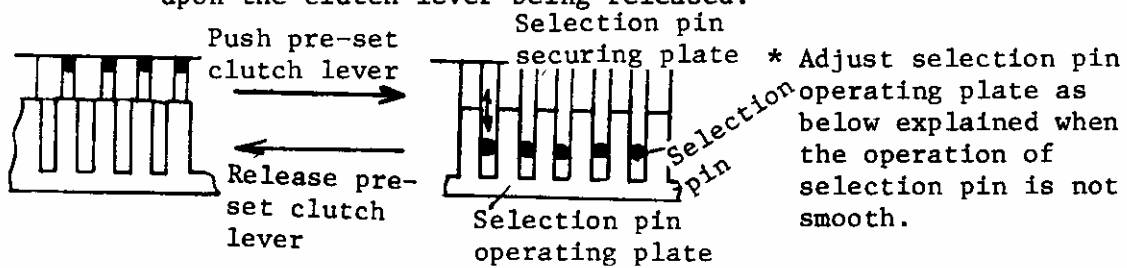

Adjustment of Selection Pin Operating Plate

(In case that vertical movement of selection pin is not smooth due to wrong position of selection pin operating plate)

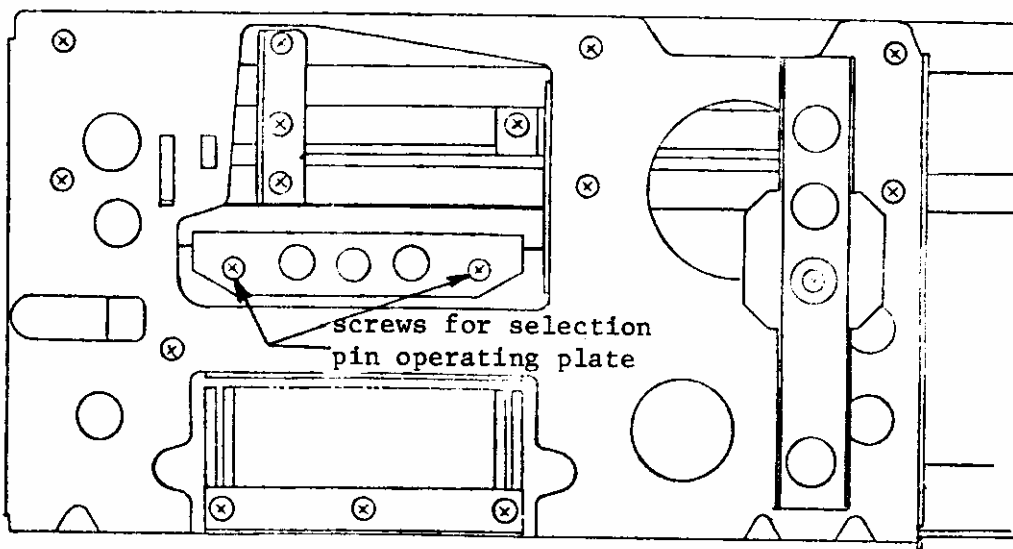

(1) Checking

Same as above item 2.

(2) Adjustment

1. Loosen screws for selection pin operating plate.
2. Lower the selection pin by pushing pre-set clutch lever.
3. Fix screws keepin selection pin engaged with slots of selection plate operating plate.
4. Check vertical movement of selection pin again.

### Adjustment of Needle Seizing Plate Position

In case the needle seizing plateslide laterally, selected needle can not be seized or seized needle is heavy.

### Checking

When push needle butt at selection position " " (D position) seizing weight upon needle should be kept within 450 - 850g.

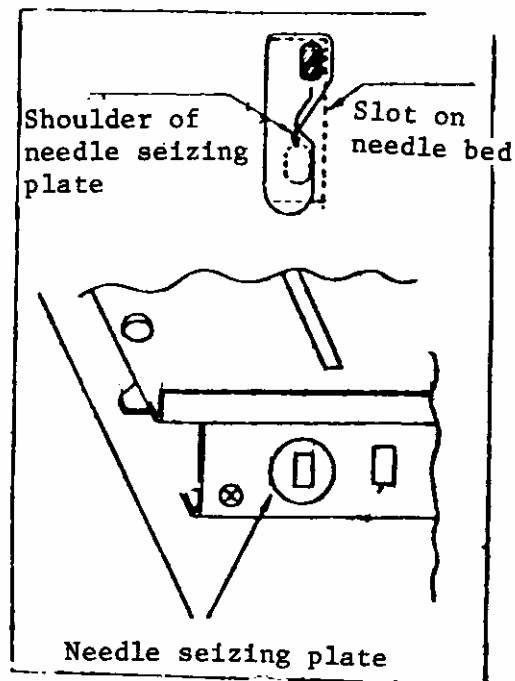

### Measurement of Reacting Weight upon Seized Needle.

- (1) Push down all manual buttons and space spring weight gauge upon needle butt. Then needle should be kept seized within 400 - 850 reacting weight. When place the gauge upon front end portion of needle, the needle should not be disengaged at less than 400 g. This checking should be conducted for at least 10 needles.

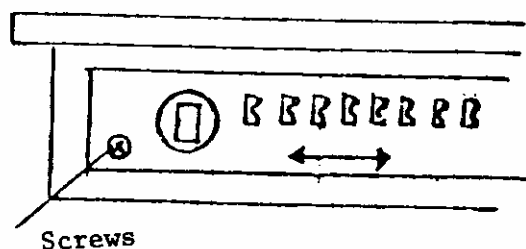
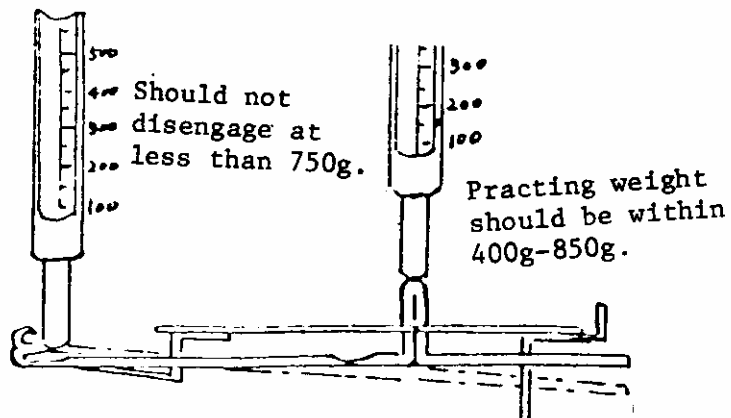

- (2) When seizing weight is more than 850g, move the needle seizing plate to right loosening fixing screws located at both ends.

When the seizing weight is less than 450g, move the seizing plate to left.

### Adjustment of Card Feeding Mechanism.

Check and adjust the card feeding mechanism, upon wrong feeding of punch card, damage of punch card or wrong needle selection.

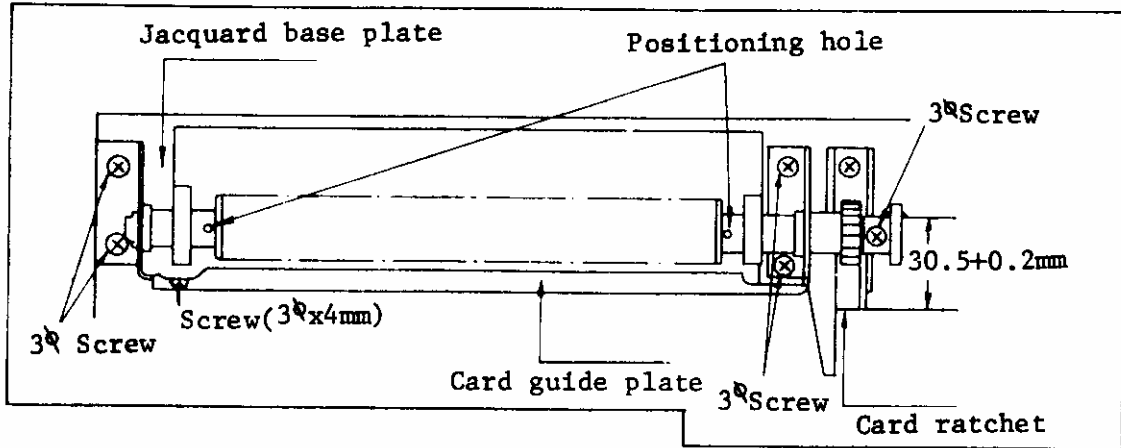

### Adjustment of Card Drum Shaft Position.

#### Checking

Rotate drum shaft by card dial and place a positioning hole upward. Then insert the longer side of selection pin (used as tool) as illustrated in the right drawing. Adjustment is needed when the pin does not go down up to end place without force.

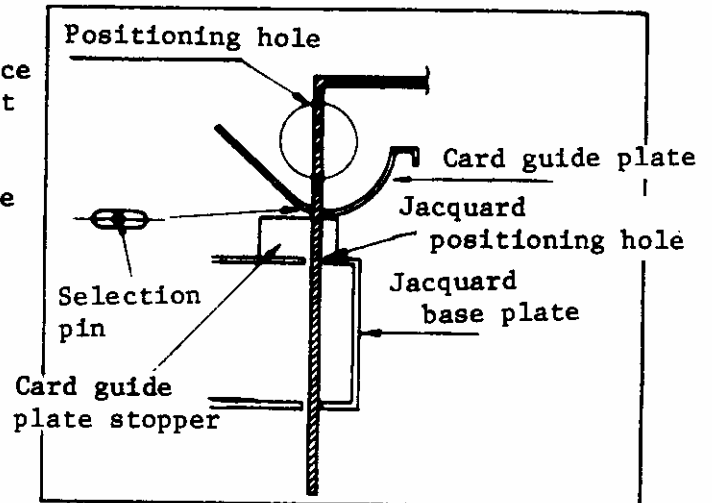

#### Adjustment

- (1) Loosen fixing screws for card guide plate, card positioning gear and drum holder (wrong - positioned side only) and fix all the screws keeping the selection pin inserted down to the end place.
- (2) If the selection pin touches card guide plate, loosen the fixing screw and make the selection pin placed in the centre of positioning hole of the guide plate. Then fix the guide plate urging the card guide plate contacted to card guide plate stopper.

## Adjustment of Card Ratchet and Card Feed Cam.

### Checking

- \*  $30.5 \pm 0.2\text{mm}$  : between card positioning gear and front end of card ratchet.
  - \*  $21.5 \pm 0.2\text{mm}$  : between card drive rod and card feed cam.
- (1) When dimension of card ratchet and card feed cam is less than the above dimension, feeding can not attain up to 1 pitch.
  - (2) When dimension of each is more than the above dimension, feeding goes more than 1 pitch and cause damage on punch card (FIG 1.)

### Adjustment

- (1) Loosen fixing screw for card ratchet and adjust the dimension from outer periphery of card feed gear shaft at  $30.5 \pm 0.2\text{mm}$ .
- (2) Loosen both fixing screws for card feed cam and adjust the dimension between card drive rod and card feed plate at  $21.5 \pm 0.2$  (FIG 2.)
- (3) When return spring of card ratchet is broken or bent, replace the spring with new one.

Upon adjustment of either dimension of  $30.5\text{mm}$  and  $21.5\text{mm}$ , also check the another dimension.

### Checking

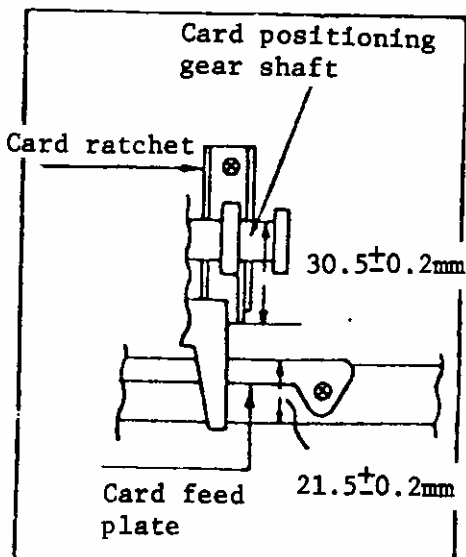

### Adjustment

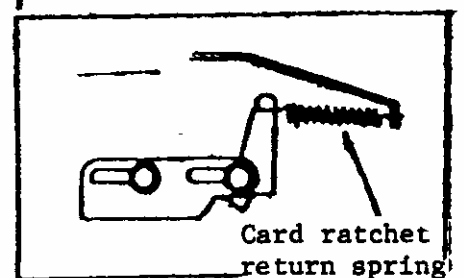
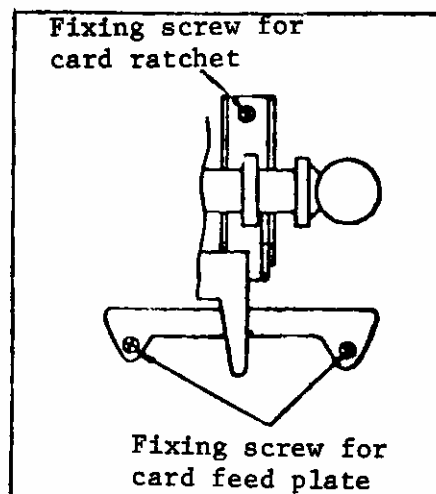



## Replacement Procedure of Needle Retaining Spring

Replace needle retaining spring according to the following procedure when the retaining spring was broken or deformed, otherwise causes latch needle slides too lightly and gives wrong needle selection.

### (Disassembling Procedure)

- (1) Take out needle bed from lower case and remove all latch needles.
- (2) Make marking on needle retaining spring set plate around fixing screw for the set plate illustrated by "x" in the right drawing.
- (3) Loosen the fixing screw and remove the needle retaining spring set plate out of needle bed.

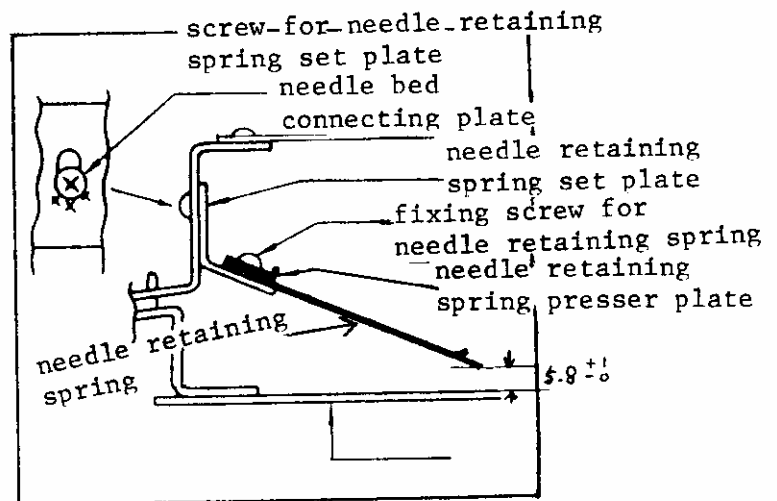

### (Assembling Procedure)

- (1) Set the needle retaining spring set plate in the needle bed installing position, and set the fixing screw in accordance with the marking. Check if the center of blade of the needle retaining spring corresponds to the center of slot on the needle bed as illustrated in the right figure, and then secure the needle retaining spring set plate by the fixing screw.
- (2) Attach all needles into slots of needle bed and assemble the needle bed to lower case.

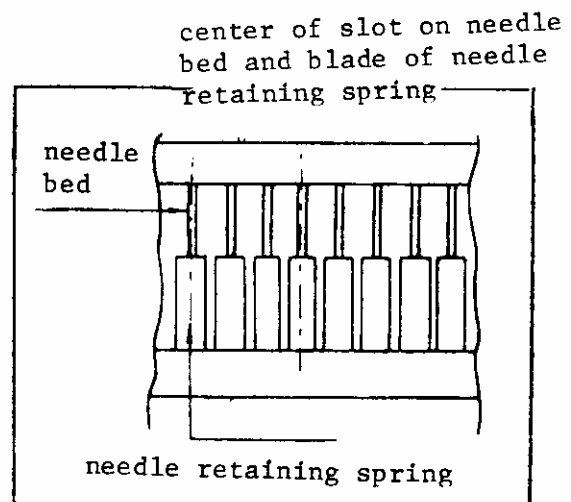

### Adjustment of Jacquard Operating Plate

Loosening of each screws for jacquard operating plate and jacquard drive transmitting plate, or play at caulking portion on the transmitting plate roller shaft, cause wrong selection both with punch card and manual selections.

### Checking

1. Check if there is no loosening at fixing screw for jacquard operating plate supporter.
2. Check the dimension between jacquard drive transmitting plate roller shaft and jacquard base plate 66 to 0.6.

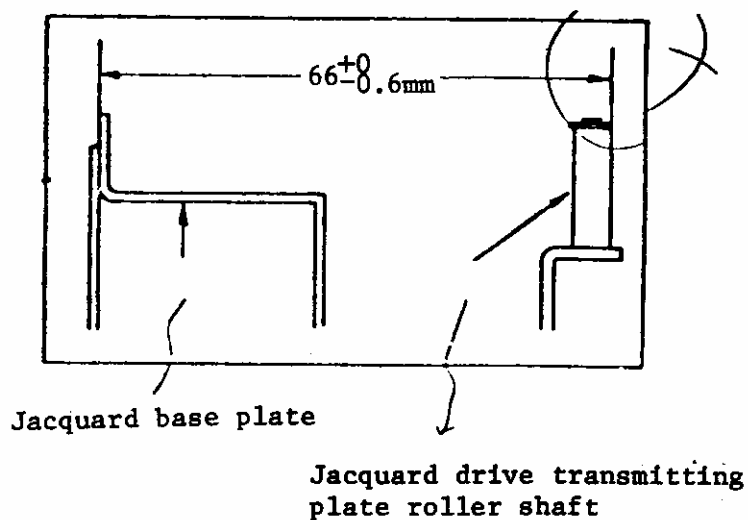

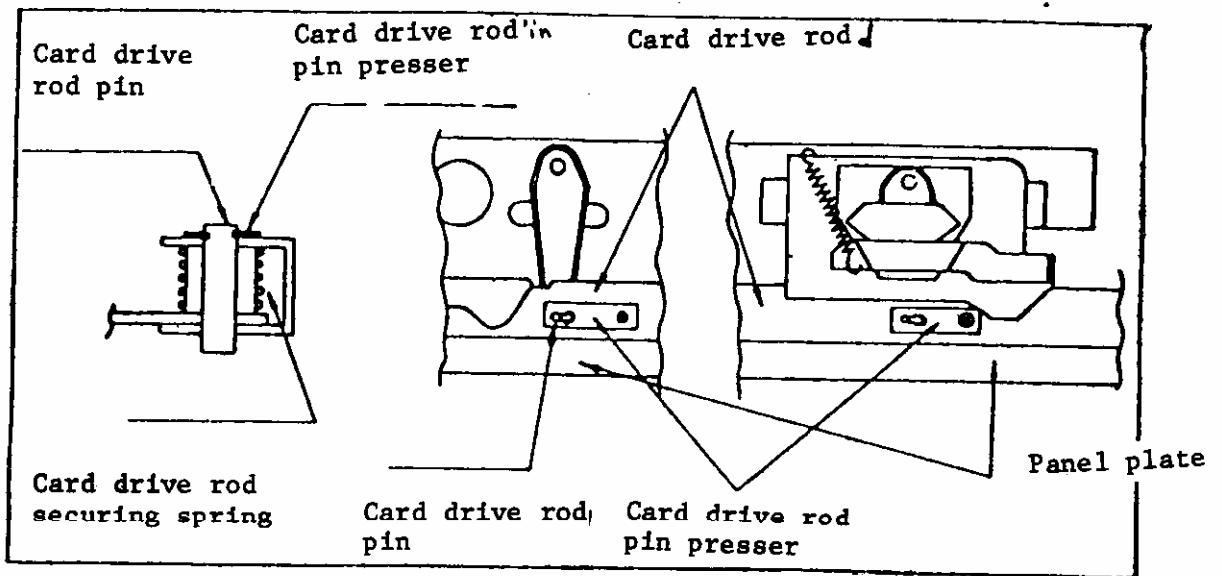

### Disassembling Procedure

1. Remove card drive rod and panel plate.
2. Take off fixing screws for card drive rod pin presser and urge the presser to left direction, thereby remove drive rod pin.
3. Pull the card drive rod and take it out from card drive rod arm. Remove card drive rod securing spring from the drive rod arm.
4. Remove panel plate by loosening two fixing screws.

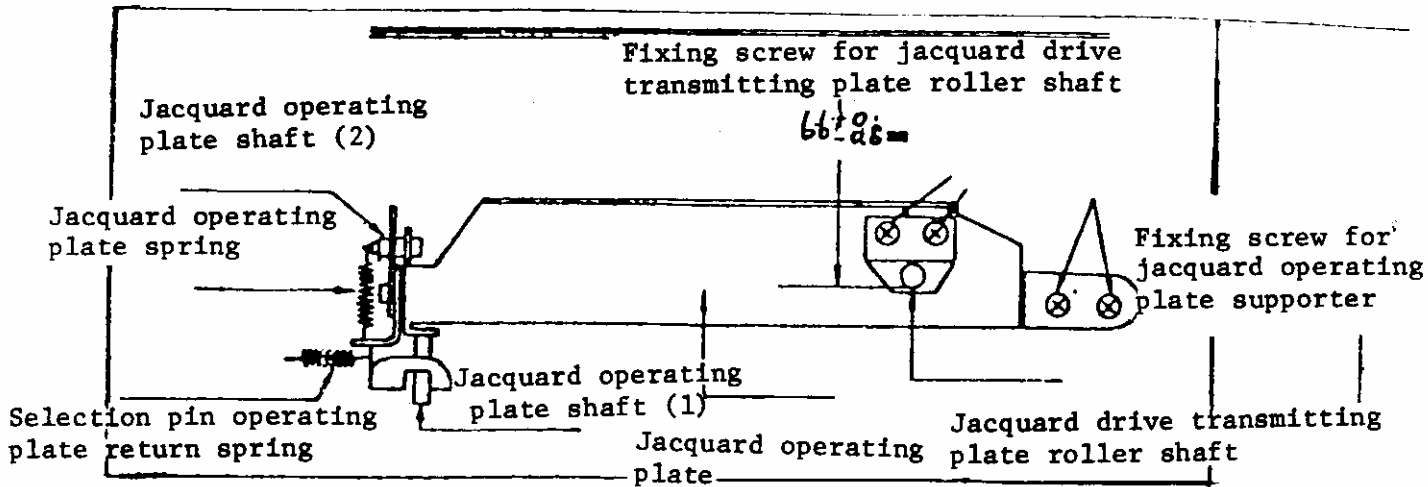

### Adjustment

1. If there is loosening at fixing screws for jacquard drive transmitting plate or jacquard operating plate supporter, tighten the screws measuring the dimension 66 to 0.6 between jacquard base plate and jacquard drive transmitting plate roller shaft.
2. If there is a play at caulking portion of jacquard drive transmitting plate roller shaft and jacquard operating plate shaft (1), repair the caulking or replace the parts.
3. If wear is found at roller shaft, replace the ring with new one.

Jacquard operating plate roller (mounted in jacquard operating plate shaft (1) (2))

Jacquard drive-transmitting plate roller (mounted in jacquard drive transmitting plate roller shaft)

#### 4. Replacement of Jacquard Operating Plate

- a) Take off E stop ring and flat washer which fix jacquard operating plate from back side of needle bed base plate (1).
- b) Take off fixing screw for jacquard operating plate base (right), and remove jacquard operating plate spring and selection pin operating plate return spring.
- c) Move the jacquard operating plate to right and raise the right side of the plate. Then, remove jacquard operating plate shaft (1) (2) from each cam.
- d) Conduct assembly in the reverse manner.

Adjust the jacquard operating plate base (right) making the play of jacquard operating plate (right, left) within 0.1mm, and check dimension  $66 \begin{smallmatrix} +0 \\ -0 \\ 6 \end{smallmatrix}$  of jacquard drive transmitting roller shaft and jacquard base plate.

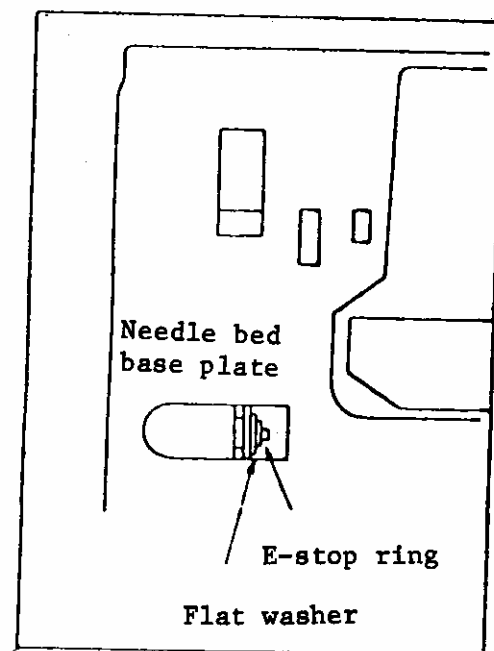

## Adjustment of Manual Plate Position

Adjust manual plates when manual plates touch upon selection pin due to wrong position of manual plates causing heavy movement of selection pin thereby giving wrong selection both with card and manual selection. But, note that the touch between manual plate and selection pin is also caused by wrong positioning of selection pin securing plate.

(Checking)

1. Take out needle bed complete from lower case.
2. Take off fixing screw for selection pin spring, and remove selection pin spring presser plate and selection pin spring.

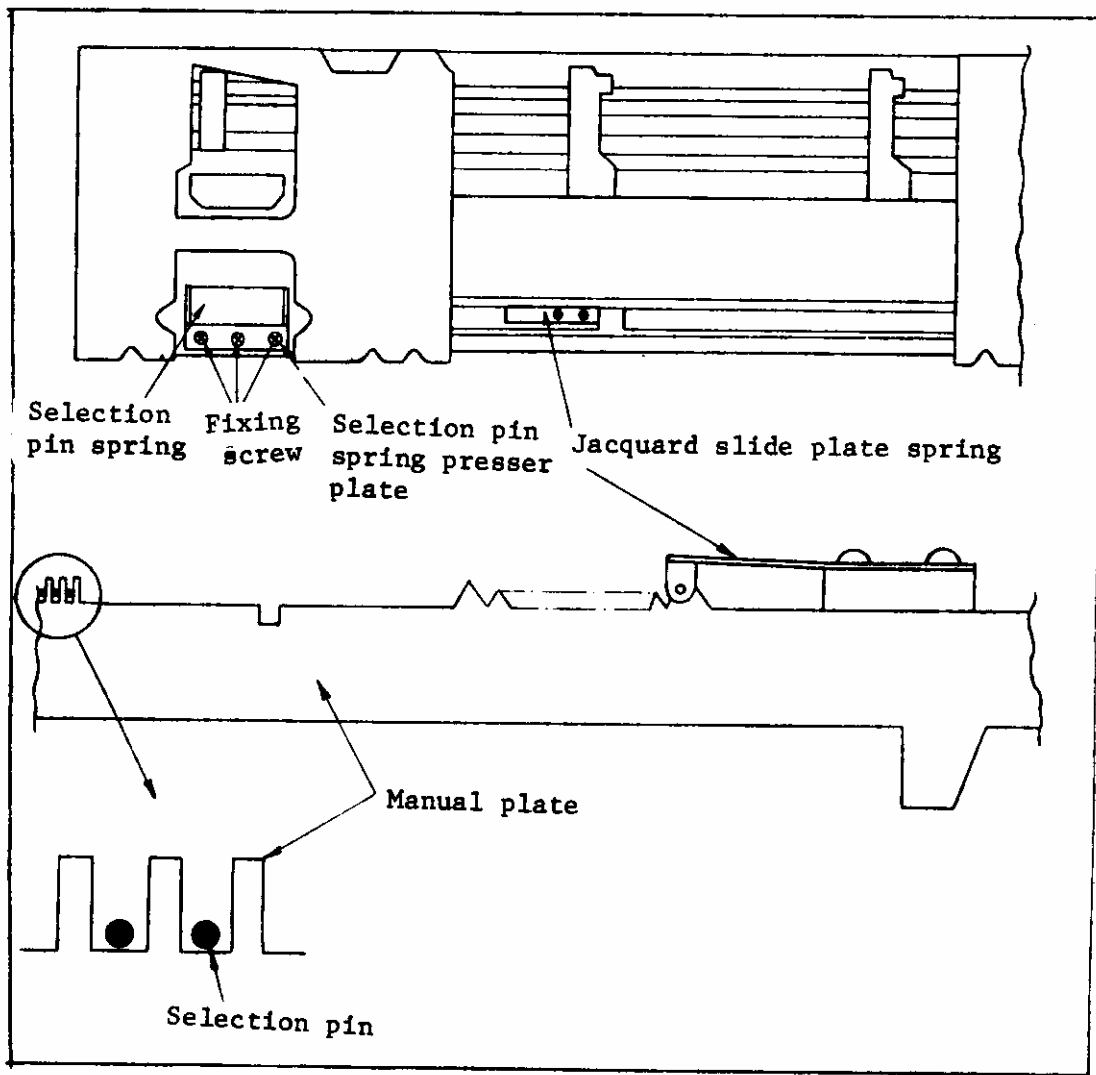

3. Check if selection pin and side surface of projection of manual plate are engaged upon the selection pin spring being removed.

Selection pin should not touch side surface of the projection.

(Adjustment)

In case that selection pin touches the side surface of the projection, adjust the position of jacquard slide plate spring that selection pin should be positioned just between projections as illustrated above.

Selection pin spring should be imposed upon in the center of selection pin as illustrated in the right figure and should not be disengaged even when the pin is moved to arrow direction by the operation of pre-set clutch lever

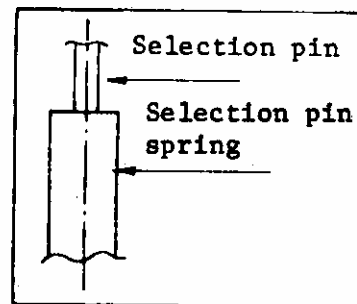

DIMENSION OF MAIN CARRIAGE

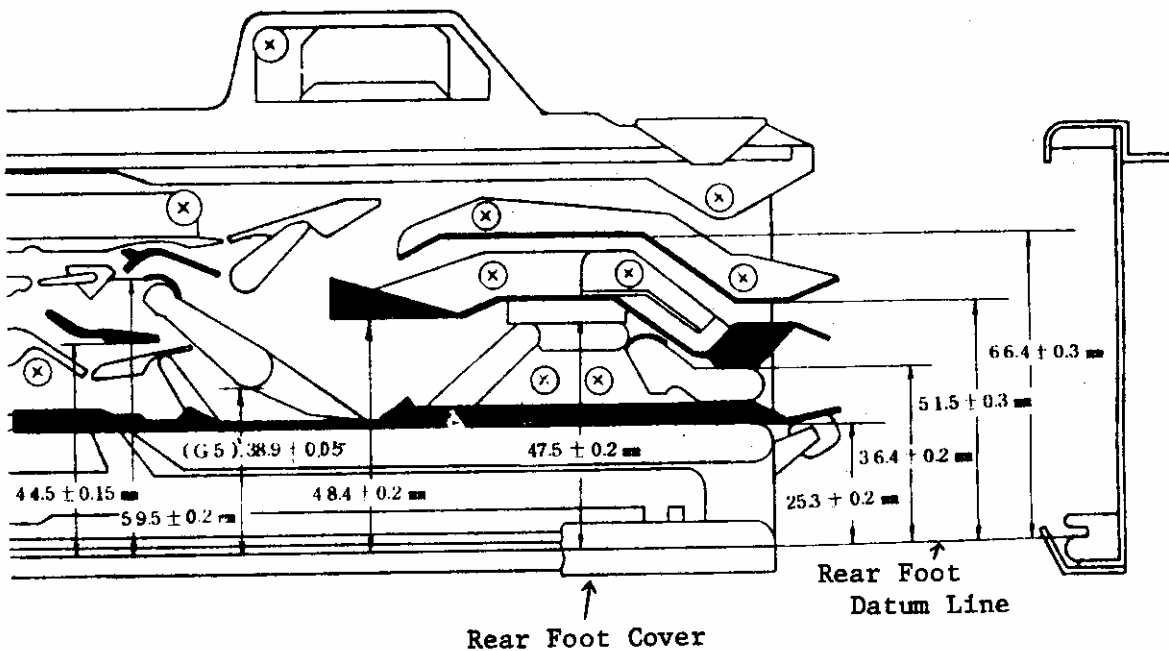

When you measure the dimensions, take off rear foot cover and measure from DATUM LINE (outer surface of groove provided on rear foot) as indicated above.

DIMENSION OF FABRIC PRESSER

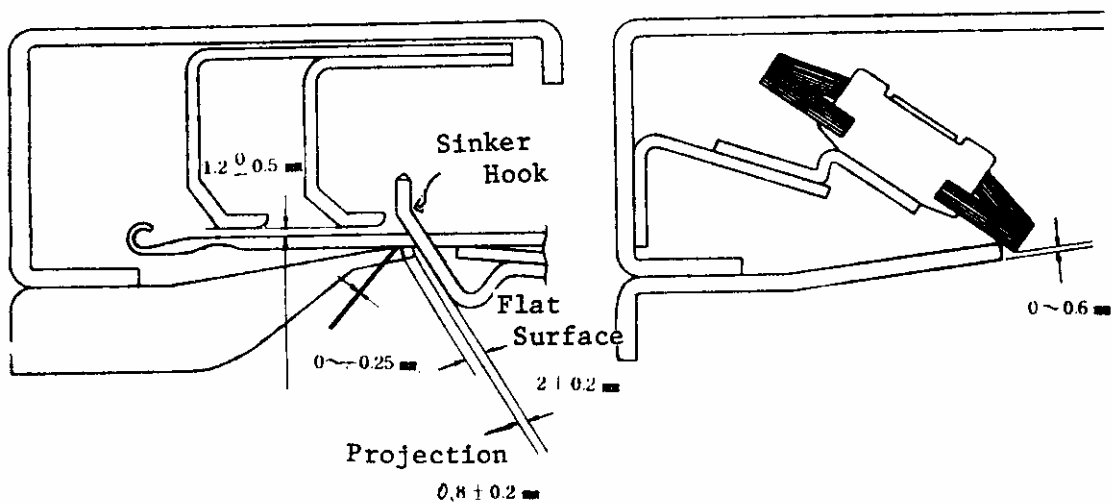

DIMENSION OF YARN FEEDER

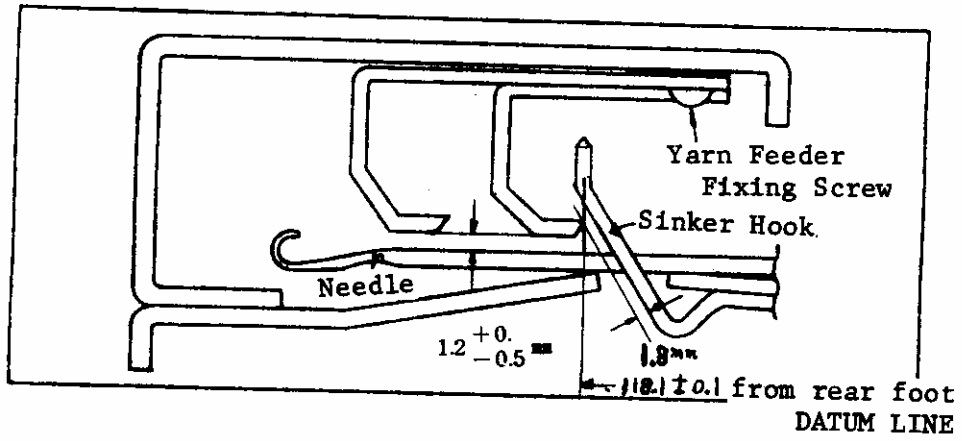



DIMENSION OF LACE CARRIAGE

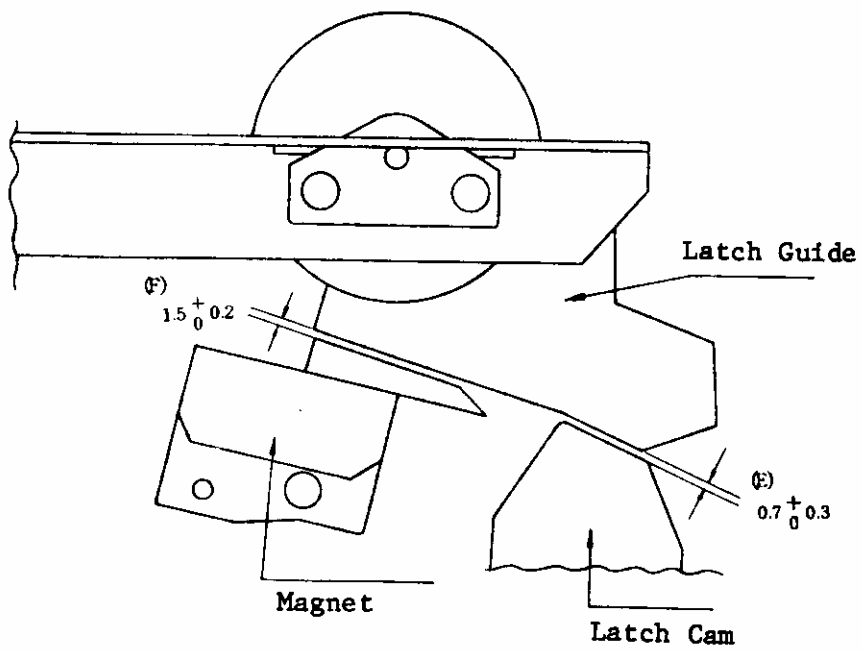
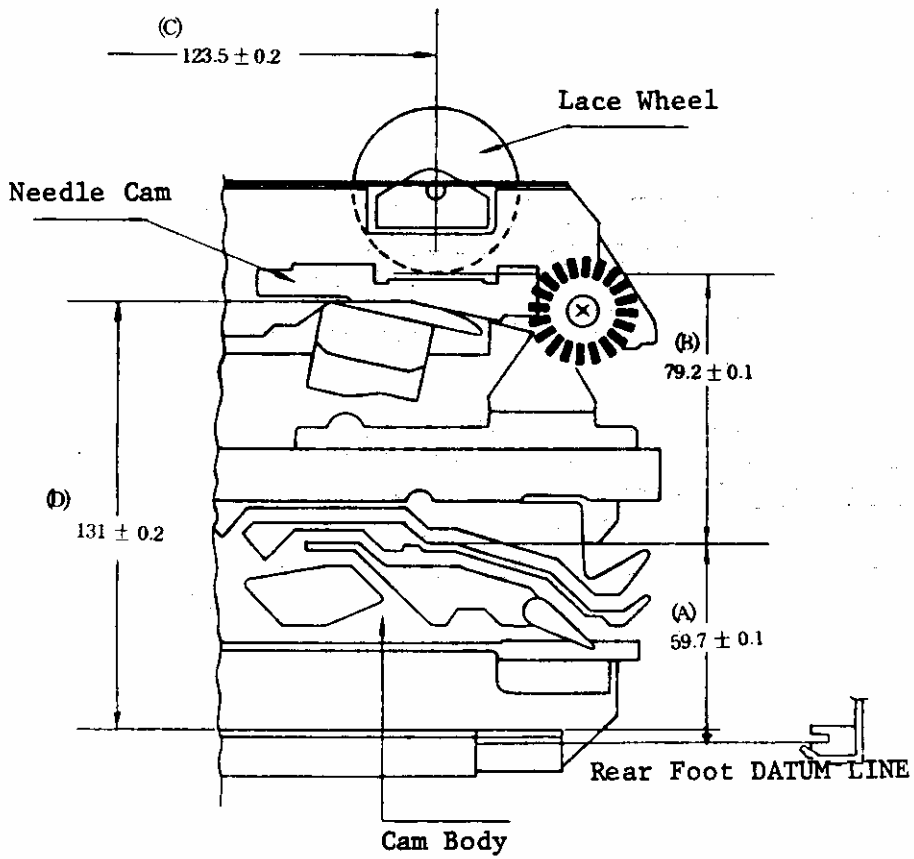

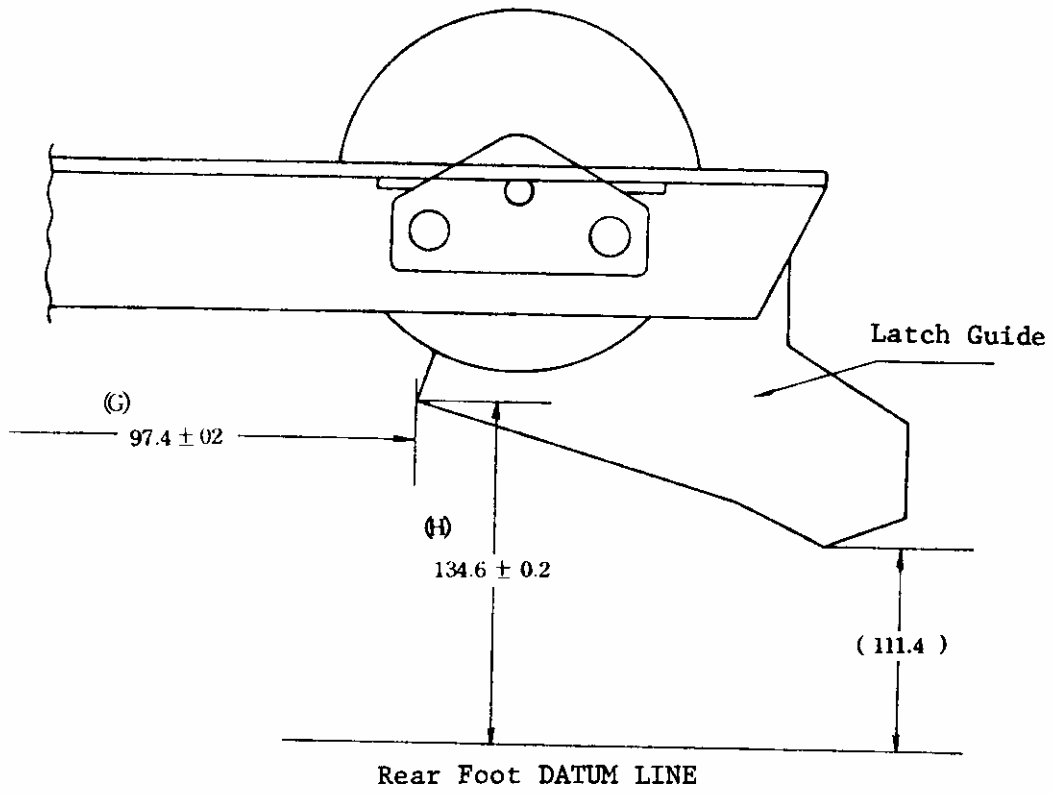

DIMENSION OF RIBBING CARRIAGE

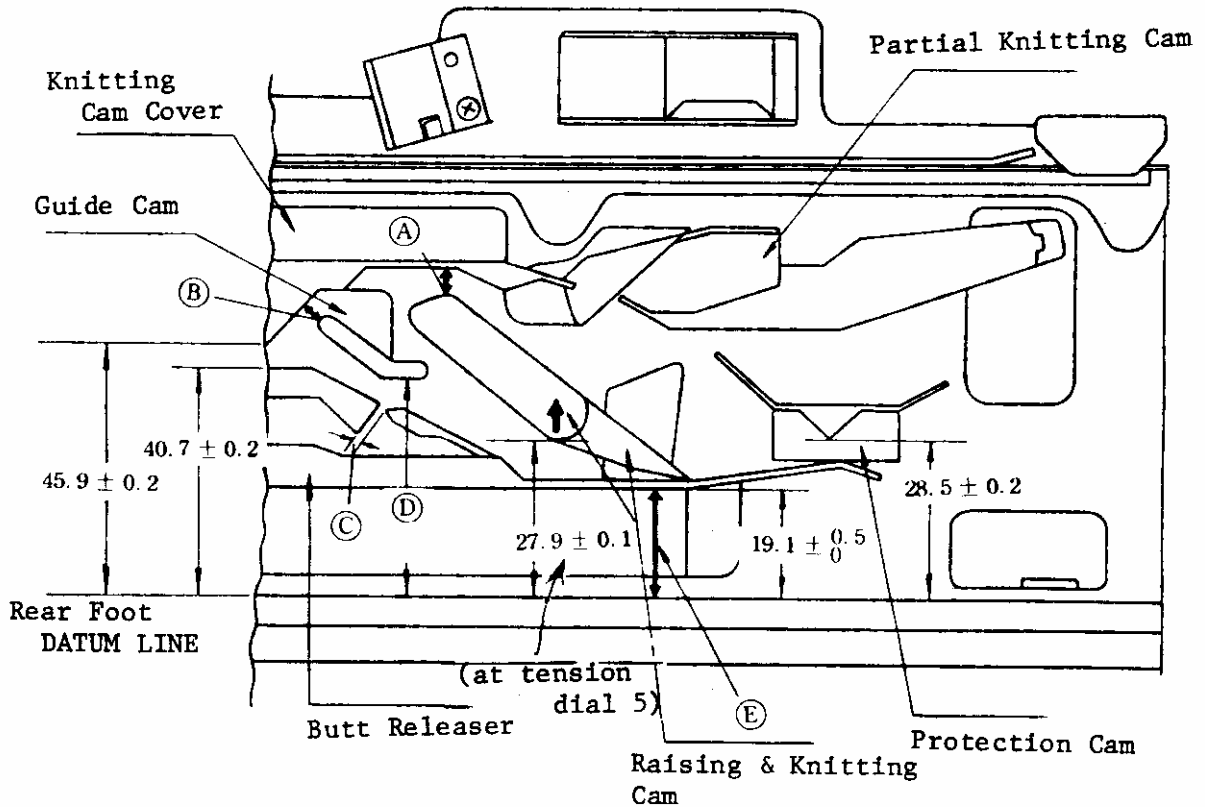

- A : This dimension should be symmetrical, right and left.
- B : This clearance must permit the passage of needle latch.
- C : This dimension should be symmetrical, right and left.
- D : This dimension should be symmetrical, right and left.
- E : Measuring position.