

**THE FOLLOWING PAGES CONTAIN THE
1ST JONES (BABY) GARMENT PATTERN
BOOK.**

**AT THE END OF THIS FILE – MANY OF THE
THE GARMENT PICTURES HAVE BEEN
REPEATED. THESE PICTURES HAVE BEEN
ALTERED TO FACILITATE ECONOMICAL
PRINTING.**

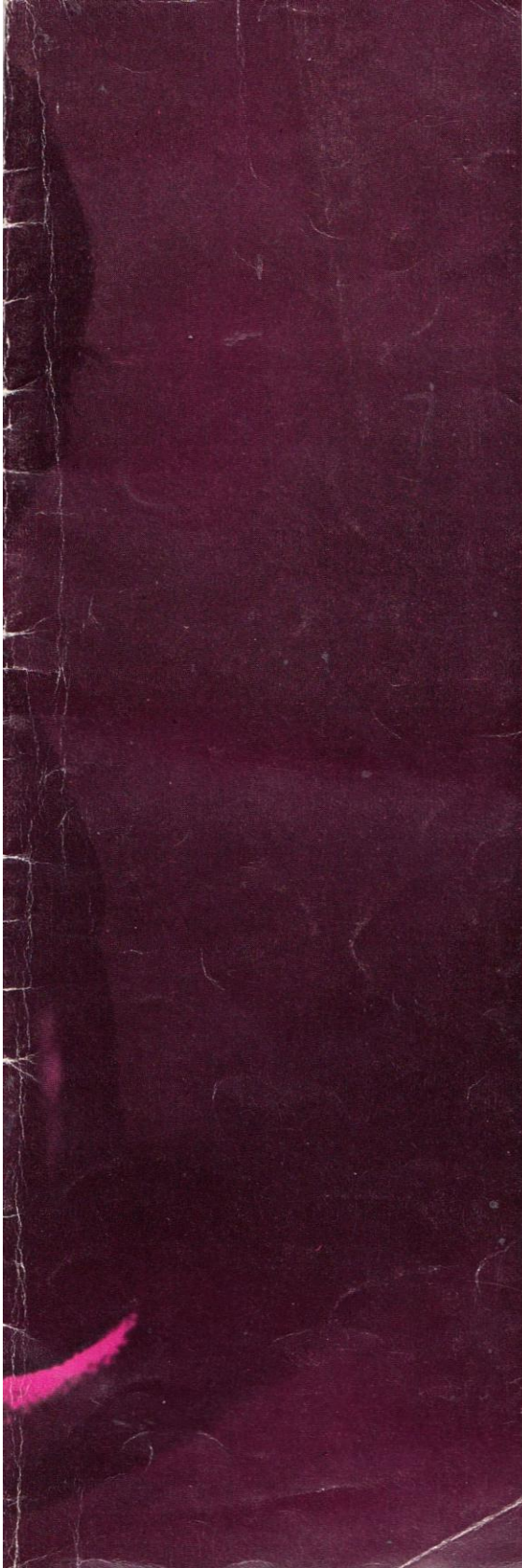

*Jones
Pattern
Booklet
No 1*

*First in
a series*

PRICE

4'6

*Babys'
Book*

Contents

2. Pram Set
 3. Lacy Pram Set
 4. Two Vests and Pilch
 5. Rompers
 6. Baby's Dress
 7. Dress
 8. Baby's Matinee Coat
 9. Sleeping Bag and Coat
 10. Bed Jacket
 11. Baby Cardigans
 12. Pram Coat
 13. Lacy Shawl
 14. Baby's Hat and Bootees
- Back cover : Pram Suit

Abbreviations and notes

ABBREVIATIONS

K.=knit; st(s).=stitch(es); inc.=increase; dec.=decrease; rep.=repeat; beg.=beginning; H.C.L.=holding cam lever; S.L.=set lever; R.D.=reverse dial; T.=tension; alt.=alternate; 000=set row counter at 0; S.D.=slide dial; P.S.B.=pattern selection button; foll.=following.

NOTES

Figures in brackets refer to the larger sizes respectively.

ADJUSTING PATTERN

Always adjust length before commencing shaping. Add or deduct the number of rows per inch as given in tension.

BUTTON BANDS

These should be at least one inch shorter than the front edge of garment. Ease edges into band evenly. Lay a wet cloth on the inside of fronts and hold a very hot iron over it, allowing the steam to penetrate. Do not press the iron on to the work. Run it very lightly over the cloth and leave the garment on the pressing table until it is quite dry. This applies to any 'fullness' that you may wish to shrink away.

CABLES

If you have difficulty when crossing and knitting cable patterns, knit the cable stitches by hand using a separate length of yarn (the ends can be sewn in later). Push the cable stitches to 'E' position and knit the row. Pass the strand of yarn made by the carriage under the cable needles and the ends of separate length of yarn to the wrong side of work.

CASTING OFF

If you find this job as tedious as most people do, here is a much quicker method. When garment is finished knit one more row to take carriage to the left side of machine. Change tension to four sizes larger than the number at which you have been working. Knit one row loosely. Push all needles to 'E' position. Using the latch hook tool take off the first stitch and push needle back. With the stitch behind the latch, take off the next stitch and hook it through the first stitch forming a chain, continue in this way to end.

NECK SHAPING

After the centre stitches for a round neck have been transferred to a stitch-holder, work the decreasings one stitch in from the edge by transferring the second stitch on to the third needle and moving the first stitch on to the empty needle. This gives a neat edge for picking up neck band stitches. When doing this knit through both loops of the first stitch and so avoid a 'ridge'.

Upholstery pins are ideal for pinning out before pressing. Most stores sell them.

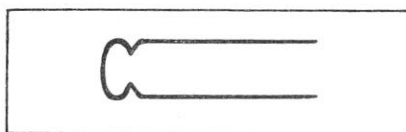

MAKE-UP (GENERAL)

Pin out and press with a warm iron over a damp cloth. Join all seams. Give final press.

To obtain correct measurements for your garment it is essential that you work to the tension given in the instructions. We suggest that you knit a sample, approximately 40 stitches by 40 rows, before knitting your garment. Remove the sample from the machine and leave it for a few hours before measuring to allow the fabric to return to its normal tension. Measure the stitches and rows in the centre of the sample piece.

Different brands of wool can be used for this garment providing that the tension measurements are exactly the same as those given here.



Pram Set

MATERIALS: Coat: 4 (5, 6) oz. Hayfield Baby Leaf Quick Knit nylon; 4 small buttons; crochet hook; small amounts of contrast for embroidery; stitch holders. **Hat:** 1 (2, 2) oz. Baby Leaf; 1 small button. **Leggings:** 4 (5, 6) oz. Baby Leaf; elastic to fit waist.

MEASUREMENTS: To fit 18 (20, 22) inch chest. Actual garment measures 22 (24, 26) inches. Length at centre back below neck band, 10 (11, 12) inches. Sleeve seam, 6 (7, 8) including cuff. **Hat:** Depth at centre back, 5½ (5½, 6½) inches. Width round lower edge, 13 (14, 15) inches. **Leggings:** Side leg, 16 (18, 19½) inches. Crotch to waist, 8½ (9½, 10½) inches.

TENSION: 7 sts. and 10 rows to 1 inch.

ABBREVIATIONS: k.—knit; st(s).—stitch(es); foll.—following; beg.—beginning; rep.—repeat; inc.—increase; dec.—decrease; E.—E position (holding position); B.—B. position (working position); R.C.—row counter; H.C.L.'s—Holding Cam Levers; T.—tension; Carr.—Carriage; L.—left; R.—right; alt.—alternate. altog.—altogether; M.—main yarn.

(Figures in brackets refer to larger sizes).

NOTE: The purl side of coat and hat is the right side. The knit side of leggings is the right side to match borders of coat.

LEFT FRONT:

Cast on by hand 71 (78, 85) sts. T. 6. K. 6 rows. Change to T. 9. K. 1 row (for folding line). Change to T. 6. K. 6 rows. Slip sts on to a st. holder. Turn and replace on to machine with K. side facing. If coat is for a boy, make buttonholes on the next row, counting from left (neck edge) over 2nd and 3rd and every foll. 20th and 21st (21st and 22nd, 22nd and 23rd) sts. 4 times altog. If for a girl, k. 1 row. Carr. must be at R. Cast on 6 sts. for hem. Change to T. 7. H.C.L.'s at III. R.C. at O. K. 2 (6, 10) rows. *Always taking yarn round inside needle in E. (to avoid making holes) push 5 (6, 6) needles at left to E. on next and every foll. alt. row 5 times altog. K. 1 row. H.C.L.'s to I. K. 4 rows. Push 25 (30, 30) needles at left to E. H.C.L.'s to II. K. 2 rows. Push 5 (6, 6) inside needles in E. back to C. on the next and every foll. alt. row 4 times altog. H.C.L.'s to I. K. 5 rows. *Carr. is at R. Rep. the last 28 rows from * to * throughout. K. 24 (24, 26) rows. Keeping shaping correct, cast off 49 (52, 56) sts. at R. 28 (32, 35) sts. remain. (Carr. is at R.)

Shape sleeve: **Cast on 10 (10, 9) sts. at beg. of next and every foll. alt. row 3 (4, 5) times altog. K. 1 row. Cast on 9 (6, 8) sts. at beg. of next row.

67 (78, 88) sts. K. 59 (63, 67) rows. Cast off 9 (6, 8) sts. at beg. of next row. K. 1 row. Cast off 10 (10, 9) sts. at beg. of next and every foll. alt. row 3 (4, 5) times altog. K. 1 row. 28 (32, 35) sts. remain. Carr. is at R. **

Shape back: Keeping shaping correct, cast on 49 (52, 56) sts. at beg. of next row. 77 (84, 91) sts. K. 111 (123, 131) rows. Cast off 49 (52, 56) sts. at R. 28 (32, 35) sts. remain. Carr. is at R.

Shape sleeve: Follow instructions for first sleeve from ** to **.

Shape right front: Keeping shaping correct, cast on 49 (52, 56) sts. at beg. of next row. 77 (84, 91) sts. K. 53 (55, 57) rows. K. 2 (2, 6) rows without shaping. Slip sts. on to a st. holder and turn. Replace on machine with K. side facing. If coat is for a girl, make buttonholes as given for boy. Cast off 6 sts. for hem. Change to T. 6. K. 6 rows. Change to T. 9. K. 1 row. Change to T. 6. K. 5 rows and cast off.

NECK BAND:

With purl side facing and commencing at inside edge of front band, pick up evenly 61 (68, 75) sts. round neck. With K. side of coat facing, place on machine. T. 6. K. 2 rows. Change to T. 5. K. 2 rows. Change to T. 4. K. 2 rows. T. 9. K. 1 row for folding line. T. 4. K. 2 rows. T. 5. K. 4 rows. Cast off loosely.

CUFFS:

With purl side facing, pick up 39 (43, 51) sts. T. 5. K. 6 rows. T. 9. K. 1 row. T. 5. K. 5 rows. Cast off loosely.

MAKE UP:

Turn hems on to inside and slip-stitch into position. Embroider fronts with the stems following the lines of shaping. Sew on buttons.

LEGGINGS:

RIGHT LEG:

Using odd yarn, cast on 68 (74, 82) sts. K. 6 rows. T. 5. Change to M. K. 10 rows. T. 9. K. 1 row. T. 5. K. 10 rows. Make hem by picking up the first row of loops in M. and placing on needles. K. 2 rows. (K. 1 row for left leg). Carr. at left.

Shape back: H.C.L.'s II. Push 60 (60, 70) needles at opposite end to carr. to E. K. 2 rows, always taking yarn round the first inside needle in E. to avoid making holes. *Push 10 inside needles in E. back to C. on next and every foll. alt. row 6 (6, 7) times altog. H.C.L.'s I. K. 1 row. Carr. at L. Inc. 1 st. at both ends of next and every foll. 12th row. 6 (7, 8) times altog. K. 14 (12, 10) rows. Cast off 2 sts. at beg. of next 2 rows. Dec. 1 st. at both ends of next and every foll. alt. row 18 (20, 21) times altog. K. 41 (47, 55) rows. Carr. at R.

Eyelet row: Press N.S.B.'s 1, 3, 5, 7 (1 and 3 for 551 model). Set lever.

Operate L. carr. from L. to R. Depress buttons. K. 1 row. Carr. at L. Slip 22 (22, 26) sts. at L. on to a st. holder.

Shape instep: K. 26 (32, 38) rows.

Shape toe: *H.C.L.'s II. Always taking yarn round the first needle in E., push 1 st. opposite to carr. end to E. on the next 14 (14, 16) rows. Push 1 needle from E. back to C. on the next 14 (14, 16) rows*. K. 26 (32, 38) rows.

Shape heel: Follow instructions for toe from * to *. Slip sts. on to a st. holder. With K. sides facing, graft or K. the two sets of sts. together.

MAKE UP:

Make two lengths of chain crochet, each about 16 (18, 18) inches long. Thread through ankle eyelets. Make and sew on tassels. Cut elastic to fit waist comfortably. Thread in top hem and secure.

HAT:

Cast on 36 (41, 45) sts. H.C.L.'s II. T. 7, always taking yarn round first needle in E. push two needles opposite carr. end to E. on the next and every foll. alt. row 6 (6, 7) times altog. K. 1 row. Push all needles from E. back to C. K. 4 rows.

Shape ear flap: Push 12 (12, 14) needles opposite carr. end to E. and cast on 12 (14, 16) sts. at beg. of next row. K. 1 row. Push two inside needles opposite carr. end from E. back to C. and cast on 2 sts. at beg. of next row. K. 1 row. Rep. the last two rows once more. Cast on 17 (18, 20) sts. at R. 69 (77, 85) sts. Carr. at R. Push 2 inside needles opposite carr. end from E. back to C. on the next and every foll. alt. row 3 (3, 4) times altog. K. 1 row. Push 2 needles opposite carr. to E. on the next and every foll. alt. row 2 (2, 3) times altog. K. 1 row. Push 2 needles opposite carr. end to E. and cast off 17 (18, 20) sts. at beg. of next row. K. 1 row. Push 2 needles opposite carr. end to E. and cast off 2 sts. at beg. of next row. K. 1 row. Rep. last 2 rows once more? Push all needles from E. back to C. and cast off 12 (14, 16) sts. at right edge. 36 (41, 45) sts. remain and carr. should be at R. Continue in pattern at left as before on the next 26 (28, 30) rows and at the same time inc. 1 st. at R. on next and every foll. 4th row. K. 2 rows. Continuing in pattern, dec. 1 st. at R. on the next and every full 4th row on the next 26 (28, 30) rows. Work second ear flap as first, making a buttonhole on the 11th row of flap over the 5th and 6th sts. from end. Complete 2nd half of back to match first half. Cast off.

TO MAKE UP:

Work 2 rows of double crochet round lower edge. Run a thread round top. Pull up and fasten off. Make pom pon and sew in position.



Lacy

MATERIALS
 Hayfield's Bab
 Medium Croct
 needles. **Legg**
 Hayfield's Bab
 fit waist; $\frac{3}{4}$ yd

MEASUREM
 18 (20, 22) in
 measurements
 Length at cent
 inches; Sleeve
 inches. **Leggii**
 crotch, $8\frac{1}{2}$ ($9\frac{1}{2}$
 16 (18, $19\frac{1}{2}$) i

TENSION: 6
 over pattern. 8
 inch over stoc
ABBREVIATI
 cover.

NOTE: When
 order of rows
 2 rows with ki
 carr. 2 rows K
 K. carr.

COAT:
BACK:
 Cast on, by ha
 T. 6. K. 2 rows
 80 (90, 100) i
 counting L cal

Shape armho
 of next 2 rows
 8 rows. Transf
 needle. Replac
 (80, 88) need
 L carr. K. 2 row
 Dec. 1 st. at b
 foll. alt. row 2
 Cast off remain

LEFT FRON'
 Cast on 80 (8
 K. 2 rows. 000
 99) rows in pi
 beg. of next r
 beg. of next a
 times altogeth
 on to a fine kr

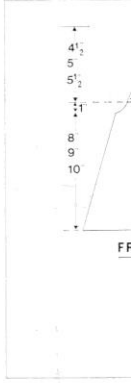

Lacy Pram Set

MATERIALS: Coat: 7 (7, 8) oz. Hayfield's Baby Quick Knit; 6 buttons; Medium Crochet Hook; 2 fine knitting needles. Leggings: 5 (5, 6) oz. Hayfield's Baby Quick Knit; Elastic to fit waist; $\frac{3}{8}$ yd. $\frac{1}{2}$ -in. ribbon.

MEASUREMENTS: Coat to fit 18 (20, 22) inch chest. Actual measurements: 22 (22, 24) inches; Length at centre back: 13 $\frac{1}{2}$ (15, 16) inches; Sleeve seam with band: 6 (7, 8 $\frac{1}{2}$) inches. Leggings: Front waist to crotch, 8 $\frac{1}{2}$ (9 $\frac{1}{2}$, 10 $\frac{1}{2}$) inches. Side leg, 16 (18, 19 $\frac{1}{2}$) inches.

TENSION: 6 sts. and 10 rows to 1 inch over pattern. 8 sts. and 10 rows to 1 inch over stocking stitch.

ABBREVIATIONS: See inside front cover.

NOTE: When working lace pattern, the order of rows is 6 rows with L carriage, 2 rows with knitting carriage, 4 rows L carr. 2 rows K. carr. 2 rows L carr. 6 rows K. carr.

COAT:

BACK:

Cast on, by hand, 156 (172, 188) sts. T. 6. K. 2 rows. Carr. at R. 000. Work 80 (90, 100) rows in pattern. (Not counting L carr. rows).

Shape armholes: Cast off 2 sts. at beg. of next 2 rows. Dec. 1 st. at beg. of foll. 8 rows. Transfer sts. on to a fine knitting needle. Replace 2 sts. on each of 72 (80, 88) needles. Carr. is at R. Remove L carr. K. 2 rows. T. 5. Continue in st. st. 000. Dec. 1 st. at both ends of next and every foll. alt. row 22 (24, 27) times altogether. Cast off remaining 28 (32, 34) sts.

LEFT FRONT:

Cast on 80 (88, 96) sts. by hand. T. 6. K. 2 rows. 000. Carr. at R. Work 79, (89, 99) rows in pattern. *Cast off 2 sts. at beg. of next row. K. 1 row. Dec. 1 st. at beg. of next and every foll. alt. row, 4 times altogether. K. 1 row. Transfer sts. on to a fine knitting needle. Replace as

follows: Counting from R. (front edge) 1 st. on first 6 needles and 2 sts. on each of 34 (38, 42) needles. Carr. at R.

Remove L. carr. K. 1 row. Continue in st. st. 000. T. 5. Dec. 1 st. at beg. of next and every foll. alt. row 14 (15, 17) times altogether.

Shape neck: Cast off 9 (10, 10) sts. at beg. of next row. Dec. 1 st. at both ends of next and every foll. alt. row 7 (8, 9) times altogether. K. 1 row. Transfer 2 sts. to centre needle and fasten off.

RIGHT FRONT:

Cast on 80 (88, 96) sts. by hand. T. 6. K. 2 rows. 000. Carr. at R. Work 80 (90, 100) rows in pattern. Now follow instructions for left front, reversing all shapings by reading L. for R.

SLEEVES: Cast on 86 (94, 102) sts. by hand. T. 6. Work 50 (60, 70) rows in pattern.

Shape top: Cast off 2 sts. at beg. of next 2 rows. Dec. 1 st. at beg. of foll. 8 rows. Remove L. carr. T. 5. Continue in st. st. dec. 1 st. at both ends of next and every foll. alt. row 22 (24, 27) times altogether. K. 1 row. Cast off remaining 10 (12, 14) sts.

CUFF BANDS:

Cast on 40 (46, 50) sts. by hand. T. 4. K. 8 rows. T. 8. K. 1 row for folding line. T. 4. K. 7 rows. Cast off loosely.

COLLAR: Cast on 86 (94, 102) sts. by hand. T. 7. 000. K. the first 6 rows of pattern. Remove L. carr. Slip 18 sts. at both ends on to st. holders. K. 12 rows. T. 5. K. 6 rows. Cast off. With right side facing pick up 16 sts. along front edge of collar. With right side facing, place sts. on machine. Replace sts. from st. holder, having 2 sts. on each of 2 sts. at lower edge and 1 st. on 14 needles to neck edge. Cast off loosely.

TO MAKE UP:

Run a gathering thread round lower edge of sleeve. With right sides facing, join band to sleeve, using a small back stitch. Turn band to inside and sew into position. Sew on collar, with front edges $\frac{1}{2}$ inch in from front coat edges. Work 2

rows of double crochet all round coat and collar. Make 6 evenly spaced button loops down left front edge. Sew on buttons.

LEGGINGS:

RIGHT LEG:

Using odd yarn, cast on 100 (106, 112) sts. T. 5. K. 6 rows. Change to M. K. 19 rows. Make hem by picking up the first row of loops in M. and placing on needles. T. 6. K. 1 row. (K. 2 rows for left leg). Carr. at R.

Shape back: H.C.L.'s to II. Push 40 (45, 50) needles at L. to E. on next and foll. alt. row. Push 8 (9, 10) needles back to C. on next 10 rows. H.C.L.'s to I. K. 74 (84, 94) rows without shaping.

Shape leg: 000. Cast off 2 sts. at beg. of next 4 rows. Dec: 1st at beg of foll: 32 (32, 34) rows Dec. 1 st. at both ends of next and every foll. 4th row (9 (11, 12) times altogether.

42 (44, 46) sts. Make eyelet row by transferring every 3rd st. to 4th needle. K. 6 rows. (76 (84, 90) rows show on R., C.).

Shape foot: Slip 10 (11, 11) sts. at L. on to st. holder. K. 1 row. Slip 11 (11, 12) sts. at R. on to st. holder. K. 24 (28, 32) rows.

Shape toe: * H.C.L.'s II. Push 1 needle to E. at opposite end to carr. on next 10 (12, 12) rows and back to C. on foll. 10 (10, 12) rows*. Slip sts. on to a fine knitting needle. Transfer the 2 sets of sts. from st. holders to machine, placing the outside sts. to centre.

Shape heel: Work as for toe from * to *. K. 24 (28, 32) rows. Slip sts. on to fine knitting needle and graft both sets of sts. together.

LEFT LEG:

Follow instructions for R. leg, but reverse shaping by noting alteration in number of rows worked after hem and reading L. for R. and vice-versa.

TO MAKE UP:

Join all seams and side seams of feet. Thread in elastic at waist and sew firmly. Thread ribbon through eyelets.

FRONT & BACK
 Measurements: 4 $\frac{1}{2}$, 5, 5 $\frac{1}{2}$, 9, 10, 11, 13 $\frac{1}{2}$, 7, 8, 9, 15, 16, 8, 9, 10, 12 $\frac{1}{2}$, 13 $\frac{1}{2}$, 14 $\frac{1}{2}$, 8 $\frac{1}{2}$, 9 $\frac{1}{2}$, 10 $\frac{1}{2}$, 7 $\frac{1}{2}$, 8 $\frac{1}{2}$, 9 $\frac{1}{2}$, 3 $\frac{1}{2}$, 4, 4 $\frac{1}{2}$.
SLEEVE

CHART
 Rows 1-14: Stitches and symbols for carriage and needle selection.
 Symbols of stitch: 1-8.

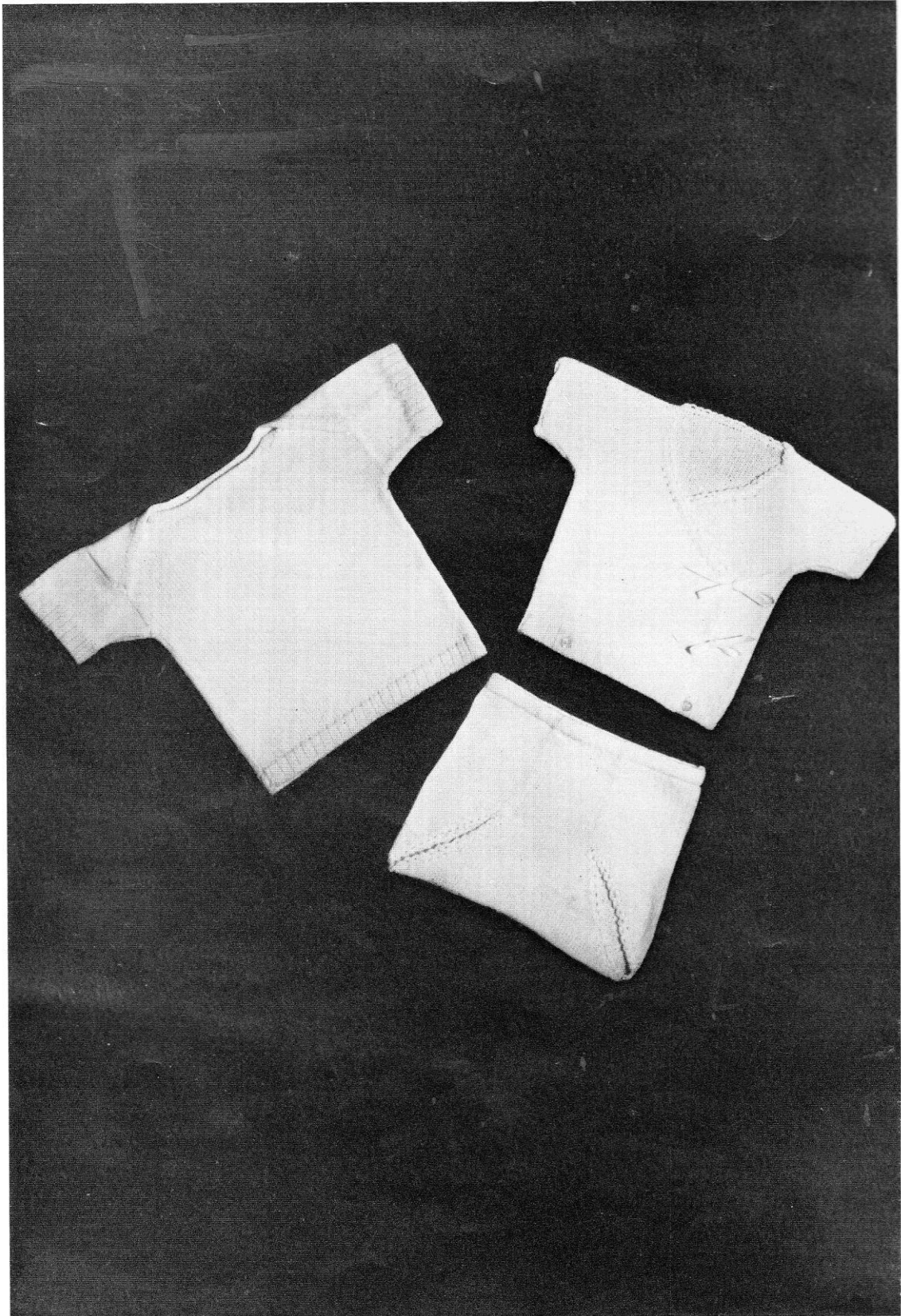

Two vests and pilch

MATERIALS: Pilch: 2 (2) oz. Hayfields Babykin; elastic to fit waist. **Both Vests:** 2 (2) oz. Hayfields Babykin. **Cross Over Vest only:** 1 yd. Nylon baby ribbon.

MEASUREMENTS: Cross Over Vest: To fit 16 (18) inch chest. Actual measurement: 17 (19) inches. Length, 10½ (11½) inches.

Envelope Shoulder Vest: To fit 18 (20) inch chest. Actual measurement: 19 (21) inches. Length, 11½ (12½) inches

Pilch: Round Seat, 19 (22) inches. Waist to crotch, 8 (8½) inches.

TENSION: 8 sts. and 10 rows to 1 inch. **ABBREVIATIONS & NOTES:** See inside front cover.

CROSS OVER VEST:

Push up 65 (73) needles in centre of needle bed**. Push every 3rd needle back to A. T. 4. Cast on. Using odd yarn, K. 6 rows. T. 4. Using Babykin, K. 8 rows. T. 8. K. 1 row to mark folding line. T. 4. K. 8 rows. Make hem by placing sts. from first row as follows: * 1 st. on empty needle and 1 st. on adjacent needle. Rep. from * to end. K. 1 row.** 000. K. 56 (66) rows. Carr. at R.

Shape sleeves and neck: Cast on 3 (4) sts. at beg. of next 10 rows. K. 34 (38) rows.

Using an odd length of yarn, cast off the centre 25 (29) sts. Slip 35 (42) sts. at left to a fine knitting needle.

LEFT FRONT: K. 9 rows. *Inc. 1 st. at neck as follows: Using double transfer tool, move the first 2 sts. 1 needle out and pick up a loop from previous row.

Place on empty needle. K. 2 rows*. Rep. from * to * 5 more times.

*** Inc. 2 sts. as follows: Transfer the first 2 sts. 2 needles out, pick up a loop from previous row and place it on first empty needle, transfer the next st. to 2nd empty needle and pick up a loop and place on empty needle. K. 2 rows***. Rep. from *** to *** 4 (6) times.

Shape sleeve: Cast off 3 (4) sts. at beg. of next and every foll. alt. row 5 times altog. AT THE SAME TIME, inc. 2 sts. at neck edge as before, on every alt. row 10 more times. 56 (62) sts. K. 46 (56) rows.

Counting from front edge, transfer every 3rd st. to its adjacent needle. K. 8 rows. T. 8. K. 1 row. T. 4. K. 7. rows. Bring empty needles to B. and cast off loosely.

RIGHT FRONT:

Follow instructions for left front, reversing all shapings.

TO MAKE UP:

Work 1 row of double crochet round neck, front edges and edge of sleeves.

Next row*: 3 chain. Miss 1 d.c. 1 single crochet in next st. Rep. from * to end. Sew on ribbon ties as shown.

ENVELOPE SHOULDER VEST:

BACK AND FRONT (Alike): Push up 76 (84) sts. in centre of needle bed. Follow instructions for Cross-over vest from ** to **. 000. K. 70 (76) rows. Tie a marking thread in both end sts. of last row. K. 34 (38) rows.

Shape neck: Cast off centre 26 (30) sts. Carr. at right. K. 3 rows. Dec. 1 st. at neck edge (by transferring 3rd st. to 4th needle and moving 2 st. along) on next and every foll. alt. row 4 times altog. Tie marking thread at armhole edge.

K. 1 row. Dec. as before 19 (20) more times. Fasten off remaining 2 sts. Work second shoulder to match, reversing shapings.

SLEEVES:

Cast on 40 (42) sts. Follow instructions for cross-over vest from ** to **. K. 2 rows. Inc. 1 st. at both ends of next and every foll. alt. row 12 (14) times altog. K. 1 row. Cast off. With right side facing, pick up 120 (128) sts. round top of neck from point to point. Place sts. on machine. T. 3. K. 4 rows. T. 6. K. 1 row. T. 3. K. 3 rows. Cast off loosely.

TO MAKE UP:

Place 2nd marking thread of back on top of 2nd marking thread of front, and tack tog. with points at first marking thread. Place centre of top sleeve on to second marking thread and sew through the three pieces—the sleeves to be 4 (4½) in. (both sides) from centre of sleeve to side edges.

PILCH:

Push up 128 (144) needles in centre of needle bed. Follow instructions for cross-over vest from ** to **. 000. K. 40 (46) rows. Tie a marking thread in both end sts. of last row.

Shape leg opening: * Dec. 1 st. at beg. of next 6 rows. Using double transfer tool, dec. 2 sts. at beg. of next 2 rows by transferring 1st and 2nd sts. onto 3rd and 4th needles. * Rep. from * to * 4 more times. Dec. 2 sts. as before at beg. of next 22 (28) rows. Dec. 1 st. at beg. of following 10 (4 rows) 24 (34) sts. Tie a marking thread at both ends of last row. K. 40 (46) rows. Transfer every 3rd st. to the adjacent needle. K. 8 rows. T. 8. K. 1 row. T. 4. K. 7 rows. Cast off.

TO MAKE UP: Join front panel to main part, matching marking threads. Crochet round leg openings as given for cross-over vest. Thread in elastic and sew firmly.

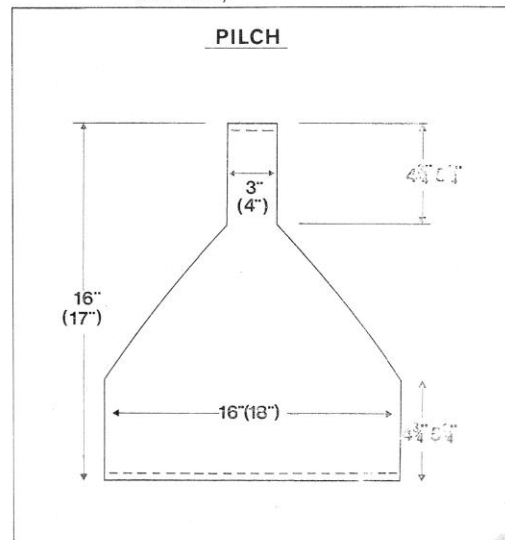
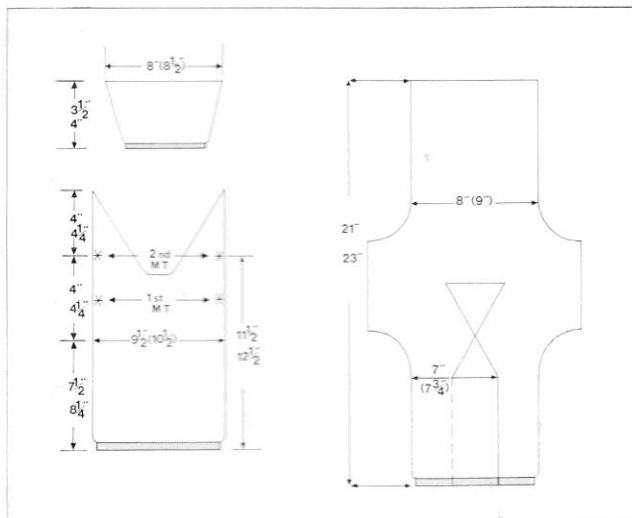

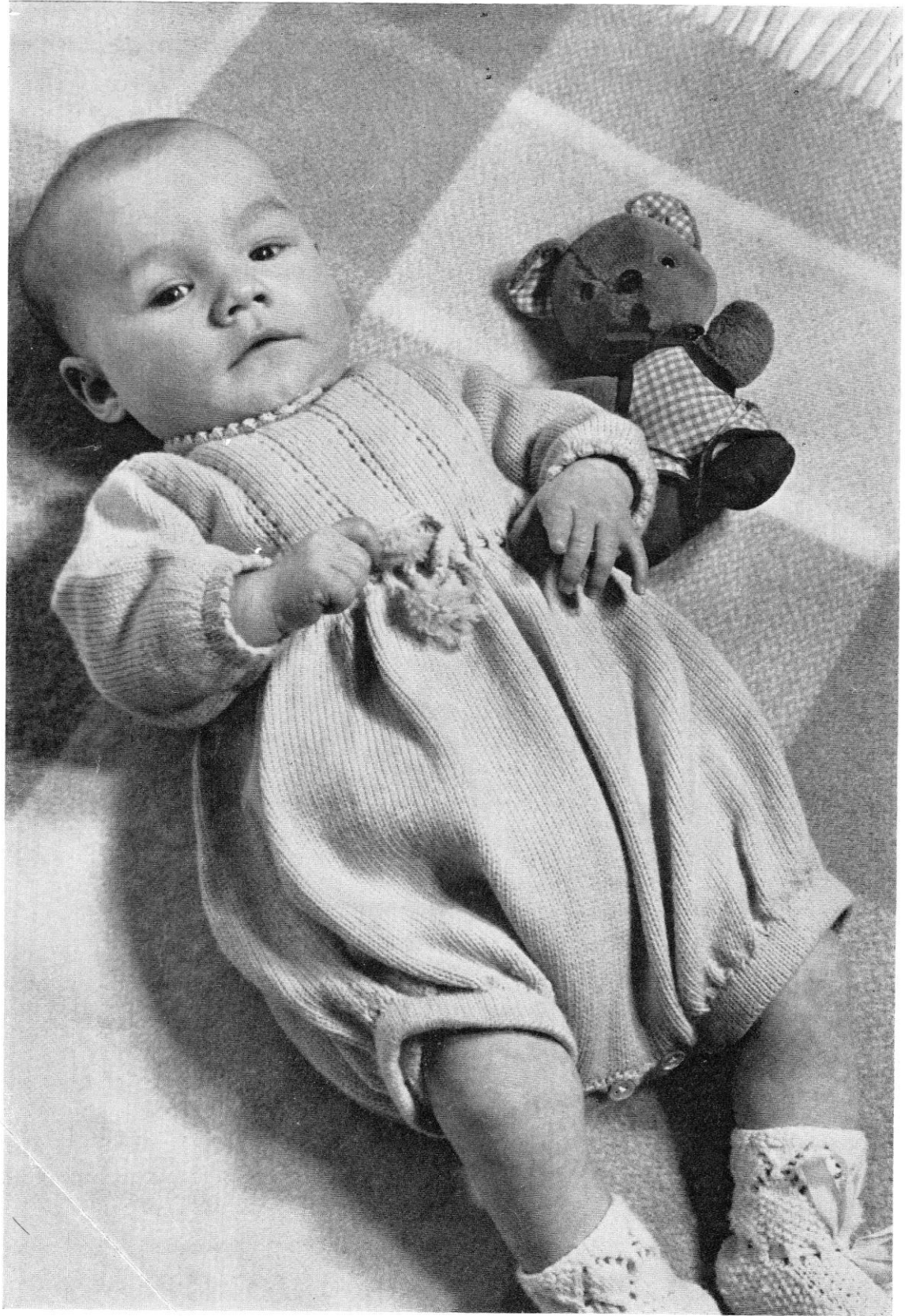

Rompers

MATERIALS: 5 (5, 6) oz. Hayfield Nylon Baby Knit; 11 small buttons; $\frac{3}{4}$ yd. $\frac{1}{2}$ -in. elastic.

MEASUREMENTS: To fit 18 (20, 22) inch chest. Actual measurements: 20 (22, 24) inches. Waist to crotch at front: $9\frac{1}{2}$ ($10\frac{1}{2}$, $11\frac{1}{2}$) inches. Centre back neck to waist: $6\frac{3}{4}$ ($7\frac{1}{4}$, $7\frac{1}{2}$) inches. Sleeve seam: $6\frac{1}{2}$ ($7\frac{1}{4}$, $7\frac{3}{4}$) inches.

TENSION: 15 sts. and 22 rows to 2 inches.

ABBREVIATIONS: See inside front cover.

BACK:

Cast on 21 (23, 25) sts. by hand. T. 5. K. 6 rows. T. 9. K. 1 row for folding line. T. 5. K. 6 rows. Make hem. K. 1 row. 000. ** Cast on 56 (58, 59) sts. at beg. of next 2 rows. 133 (139, 151) sts. H.C.L.'s II. Always taking yarn round first inside needle in E., push 52 (56, 60) needles opposite carr. end to E. on next 2 rows. Push 4 inside needles opposite carr. end to C. on the next 26 (28, 30) rows. K. 78 (88, 98) rows. Slip sts. on to a st. holder and replace on machine as follows: 1 st. on first needle. 2 sts. on each of next 22 (16, 16) needles *1 st. on next needle, 2 sts. on next needle. Rep. from * 13 (23, 27) more times, 1st. on next needle, 2 sts. on each of next 22 (16, 16) needles, 1 st. on last needle. 75 (83, 91) sts. T. 4. K. 6 rows. *Make eyelet row as follows: Press down N.S.B.'s 1, 3, 5 and 7 (1 and 3 for 551). Set lever. Take L. carr. over from L. to R. Remove L. carr. *K. 6 rows. T. 5. ** K. 20 (22, 24) rows.

Shape armholes: Cast off 3 sts. at beg. of next 2 rows. Dec. 1 st. at beg. of next 8 rows. K. 20 (22, 24) rows.

Shape shoulders: H.C.L.'s II. Push 4 (5, 5) needles at opposite end to carr. to E. on next 6 rows and 5 (4, 6) on foll. 2 rows. T. 4. K. 6 rows on centre 27 (31, 35) needles. T. 8. K. eyelet row as for waist from * to *. T. 4. K. 5 rows. Cast off loosely. Push needles at left from E to C. K. 6 rows. T. 9. K. 1 row. T. 5. K. 5 rows. Cast off loosely. Push remaining needles from E to C and complete R. shoulder to match.

FRONT:

Cast on 21 (23, 25) sts. by hand. K. 2 rows. Now follow instructions for back from ** to **. Arrange needles for pattern as follows: Push the centre st. and every foll. 10th st. at both sides of centre st. to C. 2 (3 3) times. 5 (7, 7) needles forward. Transfer 1 st. on either side to the adjacent needles outwards. Push empty needles to A. *Push the 5 (7, 7) forward needles to E. H.C.L.'s III. K. 3 rows. H.C.L.'s I. K. 1 row*. (Rep. the last 4 rows throughout). K. 20 rows. Carr. at R.

Shape neck: Slip centre 11 sts. on to a st. holder and push 25 (29, 33) needles at L. to E. K. 1 row. *Using double transfer tool, place 3rd and 4th sts. at neck edge on to 5th and 6th needles and 1st and 2nd sts. on to empty needles. K. 2 rows*. Rep. from * to * 3 (4, 5) more times. K. 3 rows.

Shape shoulders: H.C.L.'s II. *Push 4 (5, 5) needles at R. to E. K. 2 rows*. Rep. from * to * twice more. Push needles from E. to C. K. 2 rows. Cast off loosely. Work second shoulder to match, but reverse all shapings.

FRONT NECK BAND:

Taking second loop of edge st., pick up 18 (20, 22) sts. down R. side of neck. 11 sts. from centre st. holder and 18 (20, 22) sts. up L. side of neck. 47 (51, 55) sts. With P. side facing, place sts. on

machine. T. 4. K. 6 rows. T. 8. K. 1 row of eyelets as for waist from * to *. T. 4. K. 5 rows. Cast off loosely.

SLEEVES:

Using odd yarn, cast on 68 (74, 82) sts. T. 5. K. 6 rows. Change to M. K. 66 (74, 82) rows.

Shape top: Cast off 3 sts. at beg. of next 4 rows. Using double transfer tool, dec. 2 sts. (as for front neck) on the next 18 (20, 22) rows. K. 1 row. Cast off.

LEG BANDS:

Join side seams. Pick up 112 (116, 124) loops along leg edge and place on machine as follows: *2 loops on 1st needle. 1 loop on next * Rep. from * to * along the edge. 74 (77, 82) sts. T. 5. K. 8 rows. T. 9. K. 1 row. T. 5. K. 7 rows. cast off.

TO MAKE UP:

Turn hems on to wrong side and sew into position. Make 5 button loops on front crotch. (3 across centre band and 1 on each leg band). Work 3 loops across each shoulder. Using 4 strands of yarn, make a cord for waist. Thread in and trim ends with tassels. Sew on buttons.

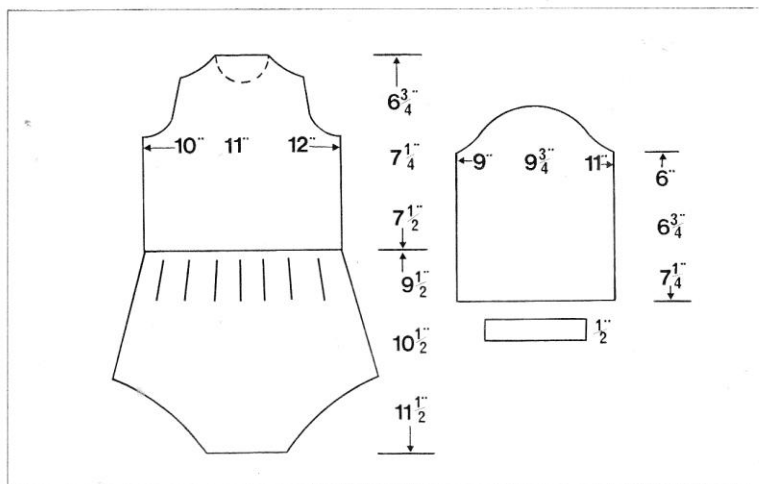

Baby's dress

Raglan, Long Sleeves, Lace Skirt. Made in Patons Beehive Baby Wool, 3 ply.

MATERIALS: 4 (5) oz.; 5 (6) small matching buttons.

SIZES: Chest, 21 (22) in.; Length, 15 (17) in.

TENSION: 8 stitches and 12½ rows per inch over stocking stitch. Stocking stitch worked at tension 2⅔ pattern tension 3⅓.

NOTES: Check tension over stocking stitch, and then work pattern ⅔ higher. R.C.O.—Row counter to "0". When working pattern keep end stitches working normally.

FRONT:

BODICE:

Cast on 98 (102) stitches, and work 24 (36) rows in stocking stitch. Now cast off 3 (4) stitches at the beg. next 2 rows. R.C.O. With the 3 eye transfer tool, move the 3rd stitch on to 4th needle and push the empty needle at the end of row in position A. (non-working pos.). Now move the 5th stitch on to 6th needle, leave this empty needle in working position, position B. (This forms holes.) These two movements to be worked at each end of row, and alternate rows to row 34 (34) counting from the commencement of raglan shapings. **Row 35. Neck shapings commence. Carriage at right.** With a spare length of wool, cast off the centre 10 (12) stitches. Place the stitch at the left in position E. holding position. Work on stitches at right as follows: Continue with raglan shaping and holes at right. At neck end cast off 2 stitches on alternate rows 3 (3) times, and decrease 1 stitch on alternate rows 2 (2) times. Keep neck end straight, and continue with raglan shaping and holes until 5 sts. remain. Continue with raglan shaping **only** (twice more) until 3 stitches remain. Cast off.

BACK:

LEFT SIDE:

Cast on 53 (55) stitches. Work 24 (36) rows. (25 and 37 rows for right side of back.) Now cast off 3 (4) stitches at right, knit the row and 1 more. Carriage now at right. R.C.O. **Raglan shaping:** Work at right only in the same manner as at front, keeping left end straight. Knit up to row 55 (55) Carriage now at left. **Row 56 (56):** Cast off at left (neck end) 8 (8) sts., then 7 (8) sts. on alternate rows. At the same time working shapings at right. The last raglan (and holes)

shaping being on row 59 (59). **Row 60:** Knit Cast off the remaining 5 stitches. (Note there are 30 holes and shapings). 28 holes have been worked at the front.)

RIGHT SIDE:

Work exactly as for front, **but reverse shapings.**

SLEEVES:

Cast on 60 (62) stitches. Knit 4 rows. Next row: Transfer sts. for picot edge. Place every 2nd stitch on its adjacent needle to right, leave the now empty needle in working position, position B. Knit the row. Now knit 4 rows. Take off casting on comb. Hook up casting on loops to the needles immediately above, to form hem. Push all needles into position E. K. 1 row. **Row 11:** Make holes for tie by transferring every 2nd stitch on to the adjacent needle to right. Leave empty needles in position B., working position. Knit the row and 1 more. R.C.O. Carriage at right. Now increase 1st each end on next and every 8th foll: (10th) row until there are 76 (78) sts. Knit straight to row 70 (82). Cast off 3 (4) stitches at beg. of next 2 rows. R.C.O. **Raglan shaping:** Transfer stitches each end as for front bodice, up to and including row 56 (56). **Next row:** Transfer stitches at **left** as before—working hole—but at **right** transfer 3rd st. on to 4th needle, omit hole. (Empty needle at end back to position A.) Knit the row and 1 more. **Next row:** Carriage at right. Cast off 3 stitches at right. Transfer stitches at left as before, working hole. Knit the row and 1 more. **Next row:** Carriage at right. Cast off 3 stitches at **right**. At **left** transfer 3rd st. on to 4th needle only. Omit hole. Knit 1 row. Now cast off the remaining 4 stitches from left to right. Work second sleeve, but reverse shapings.

SKIRT:

FRONT:

Tension 3⅓. Cast on 69 (77) stitches left of centre, and 62 (70) stitches right of centre. Knit 5 rows stocking stitch. Work picot edge. Transfer every 2nd stitch on to its adjacent needle to the right. Leave empty needle in position B, Knit the row and 5 more. **Now change to pattern.** Knit 88 (104) rows in pattern. * Press keys 3 and 6, set, take cot over from left to right. Place the now empty needles in position A. Knit 1 row from right to left. Now with the lachet needle, cast off the crochet method. *

BACK:

Work in the same manner as skirt front up to row 72 (88). Divide for back opening. Place 65 (73) stitches at left on stitch holder. Take care to replace

the stitches on same needles when required, thereby keeping the correct pattern sequence. Continue working on the stitches 66 (74) at right, stitches. Knit up to row 88 (104) then from * to * as at front.

Place the stitches for left back on machine, pick up a loop to make an extra stitch at right. Work as for right side of back opening.

NECK:

This is worked after the raglan sleeves have been sewn to the bodice. Pick up evenly 95 (99) stitches round the neck (†see note below) with knitting needle, knitting each stitch as it is picked up. Place on machine. * Transfer every second stitch on adjacent needle to right, leave empty needle in position B. Knit the row and 4 more *. Repeat from * to * once more. Now transfer every second stitch on to adjacent needle to the right, leave empty needles in position B. Knit the row. Change to tension 9. Knit 1 row. Cast off the crochet method.

Ties for waist, neck and sleeves:

Cast on 4 sts. tension ⅔. Press in right part button. Work until row counter reads 250 for sleeves, 400 for neck and 700 for waist. Break off wool and thread the 4 stitches with needle, finish off. †Commence picking up these stitches on the 5th stitch from the neck opening and end on the 5th stitch.

MAKE UP

Block and press all sections of garment. Stitch sleeves into bodice, using back stitch. Press seams open. Work neckline. Stitch down, the middle row of holes forming the picot. Match the holes at the bottom, as the neck tie is to be threaded through these. Back of bodice. Turn back the 4 stitches at each side for button stand. Work 5 (6) loops for buttons. Space these evenly. Backstitch front skirt to front, and the same at the back. Join side seams of skirt. Backstitch sleeve and bodice seams. Work loops for belt on side seams, and 2 at back, spaced evenly, and the same at the front. Give final pressing. Stitch on buttons. Thread ties in neck, sleeves and waist.

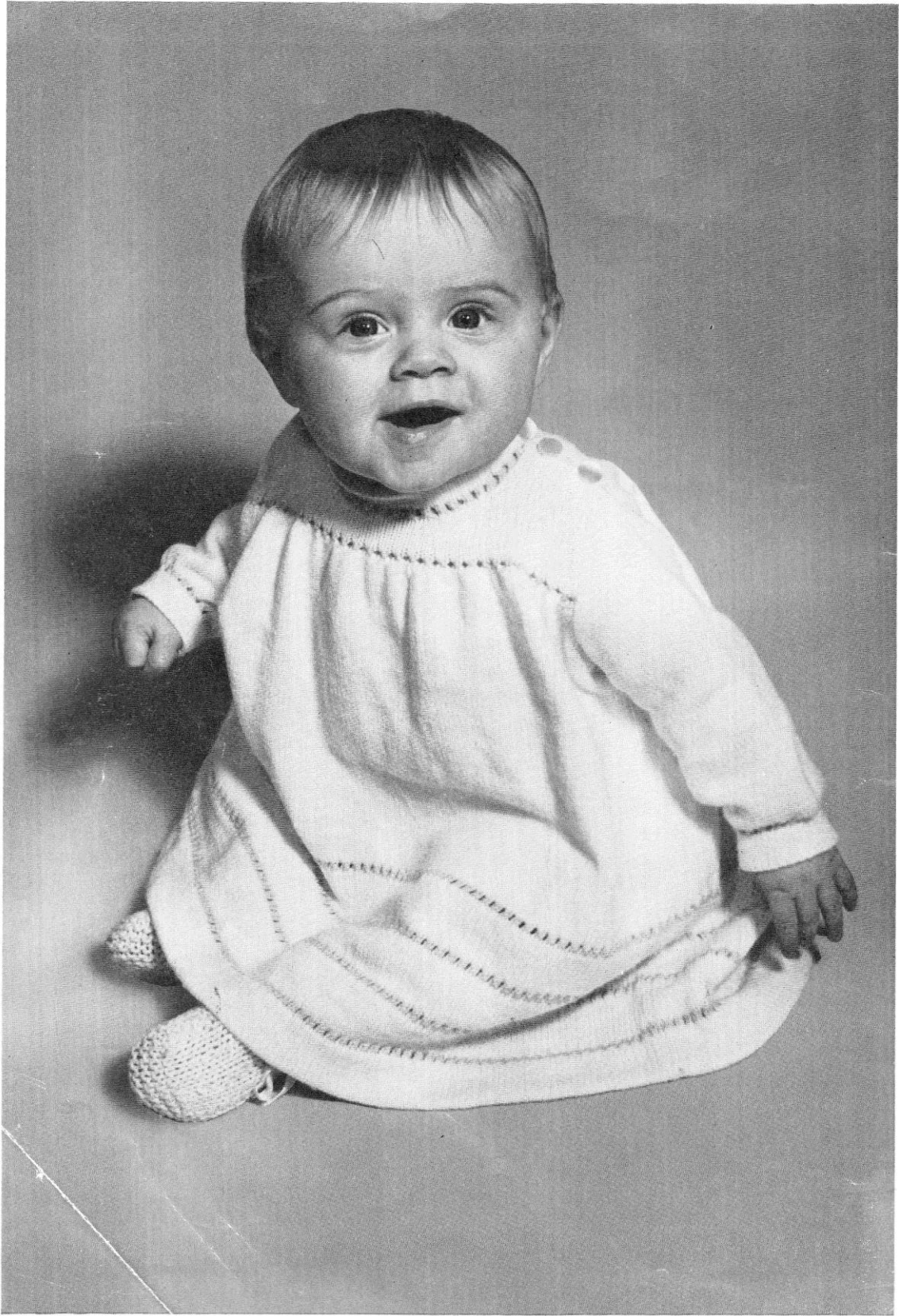

Dress

MATERIALS: 5 (6, 7) oz. Hayfields baby Knit in Main colour. 1 oz. of Contrast colour. 8 small buttons. Medium crochet hook. 2 stitch holders.

MEASUREMENTS: To fit 18 (19, 20) inch chest. Actual measurement: 20 (21, 22) inches. Length at Centre Back, 14 (14½, 15½) inches. Sleeve seam, 6½ (7, 7½) inches.

TENSION: 8 sts. and 12 rows to 1 inch.

ABBREVIATIONS: See inside front cover.

BACK:

** Using odd yarn, cast on 152 (168, 176) sts. T. 4. K. 6 rows. Change to M. K. 14 rows. T. 9. K. 1 row for folding line. T. 4. K. 14 rows. Make hem by placing loops from first row of M. on to needles. K. 1 row. Carr. at R.

* Using C. K. 1 row.

Press down N.S.B.'s 1, 3, 5, 7 (1 and 3 for 551). Set lever. Take L. carr. over from L. to R. Still using C. K. 1 row. Break off C. Using M., K. 14 rows *. Rep. from * to * three more times. K. 50 (54, 56) rows.

Shape armholes: Cast off 4 sts. at beg. of next 2 rows. Cast off 2 sts. at beg. of foll. 12 (14, 14) rows. (120 (132, 140) sts.) Slip sts. on to st. holder and replace on machine with 2 sts. on each of 60 (66, 70) needles. Rep: once more from *. **K. 10 (12, 16) rows. H.C.L.'s II. Push 5 (6, 6) needles at opposite end to carr. to E. on next 4 rows and 6 (6, 7) on foll. 2 rows.

Using C., work the 2 eyelet rows. Break off C. K. 6 rows on centre 28 (30, 32) sts. T. 9. K. 1 row. T. 4. K. 5 rows. Cast off loosely. Push remaining needles from E. to C. and complete R. shoulder to match.

FRONT:

Follow instructions for back from ** to **. K. 10 rows. H.C.L.'s II.

Shape neck: Slip centre 12 (14, 16) sts. on to a st. holder and push 24 (26, 27) needles at L. to E. K. 1 row.

Using double transfer tool, place 3rd and 4th sts. at neck edge on to 5th and 6th needles and 1st and 2nd sts. on to empty needles. K. 2 rows. Rep. from * to * 3 more times. K. 4 (6, 8) rows. Carr. at L.

Shape shoulder: *Push 5 (6, 6) needles at R. to E. K. 2 rows. *Rep. from * to * once more. Push needles from E. to C. K. 2 rows. Cast off loosely. Work R. shoulder to match, but reverse all shapings.

FRONT NECK BAND:

Taking 2nd loop of edge st., pick up 18 (20, 22) sts. down R. side of neck,

12 (14, 16) sts. from centre and 18 (20, 22) sts. from L. side. 48 (54, 60) sts.

With P. side facing, place sts. on machine. Using C., work the 2 eyelet rows. Break off C. K. 6 rows. T. 9. K. 1 row. T. 4. K. 5 rows. Cast off loosely.

SLEEVES: Using odd yarn, cast on 68 (72, 76) sts. T. 4. K. 6 rows. Change to M. K. 66 (72, 78) rows.

Shape top: Cast off 4 sts. at beg. of next 4 rows. Cast off 2 sts. at beg. of next 16 (18, 18) rows. K. 1 row. Cast off remaining 20 (20, 24) sts.

CUFFS:

Pick up the first row of loops at lower sleeve edge and place on needles as follows: 6 (8, 8) sts. on first 6 (8, 8) needles. 2 sts. on each of 28 (28, 30)

needles and 6 (8, 8) sts. on next 6 (8, 8) needles. 40 (44, 46) sts.

Using C., work the 2 eyelet rows. Break off C. Using M., K. 12 rows. T. 9. K. 1 row. T. 4. K. 11 rows. Cast off loosely.

TO MAKE UP:

Turn neck, shoulder, and sleeve hems onto P. side, and sew into position. Run a gathering thread round top of sleeve. Sew into armhole, spreading gathers evenly. Make 4 evenly-spaced button hole loops along front shoulder edge. Sew on buttons.

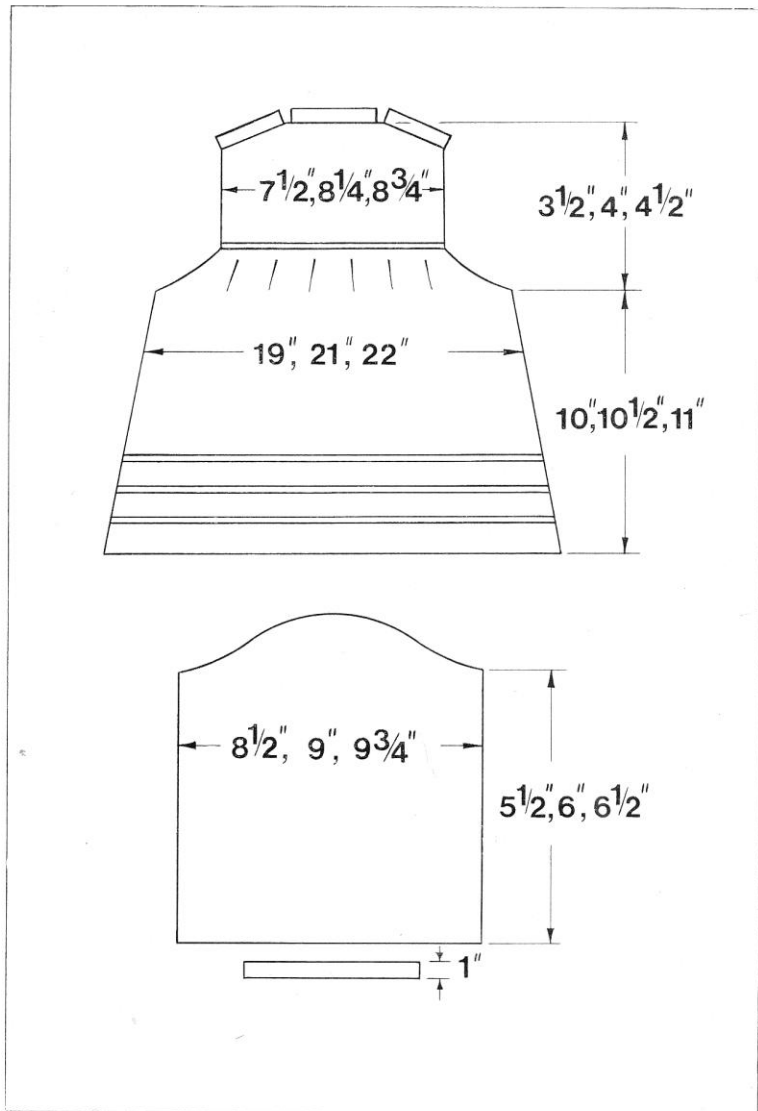

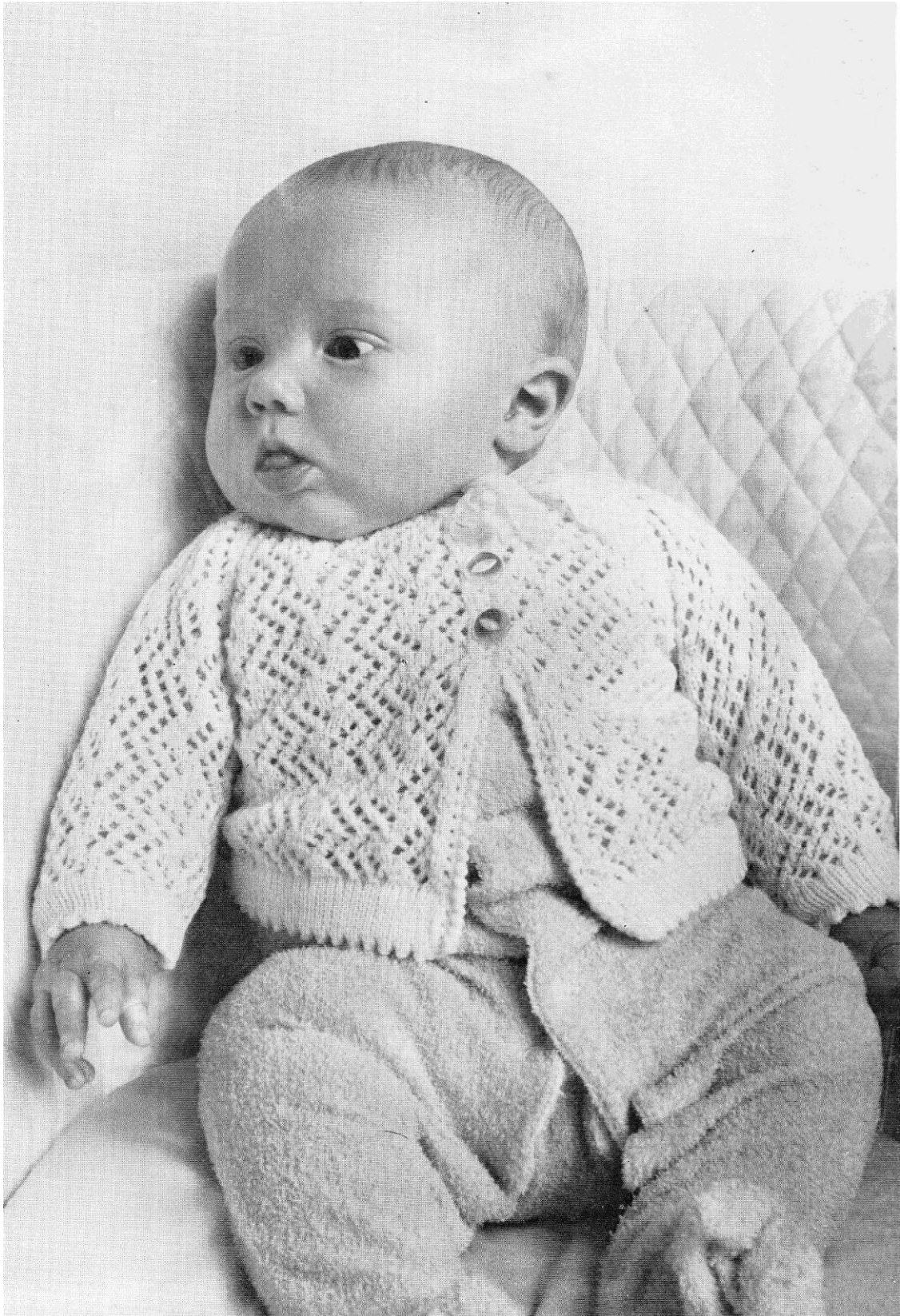



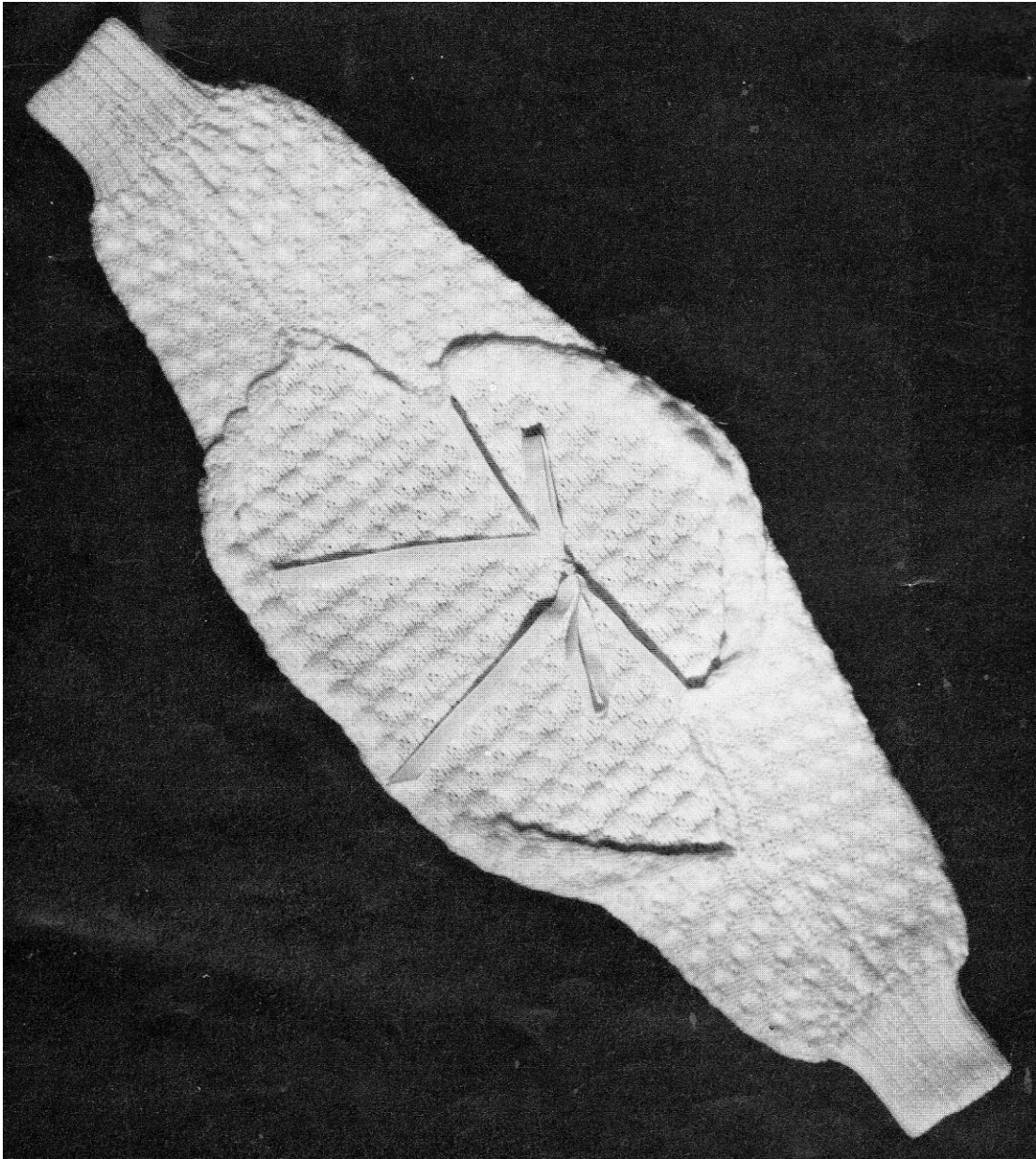

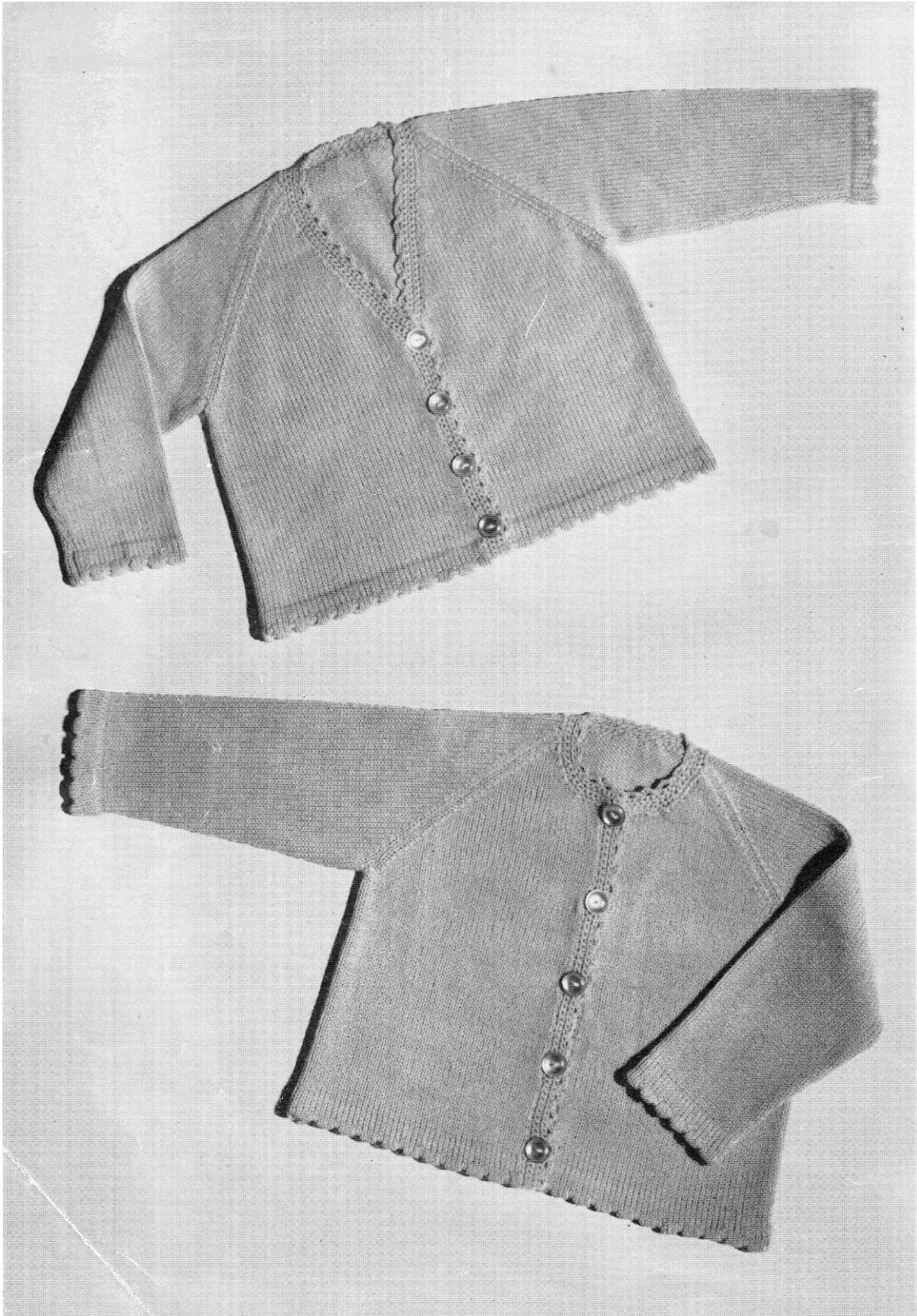

Baby Cardigans

Vee and Crew neck.

MATERIALS: **Vee Neck:** 3 (3, 4) oz. Hayfield Babykin wool; 4 buttons.
Crew Neck: 3 (3, 4) oz. Hayfield Babykin wool, 5 buttons.

MEASUREMENTS: To fit an 18 (20, 22) inch chest; Length, 10 (11, 12) inches; Sleeve seam, 6 (7, 8) inches (adjustable).

TENSION: 17 sts. and 23 rows to 2 ins.

ABBREVIATIONS: See inside front cover.

BACK:

Cast on 87 (95, 103) sts. * T. 4. K. 6 rows. SD. 3. T. 3. NSB. 1 and 5. H.C.L.'s III. SL. to Set. K. 6 rows. H.C.L.'s I. T. 4. K. 6 rows. Make a hem *. 000. K. 54 (60, 66) rows.

Shape raglan armholes: Cast off 3 sts. beg. next 2 rows. Dec. 1 st. both ends (see notes) on next and every foll. alt. row 25 (28, 31) times altogether. K. 1 row. Cast off remaining 31 (33, 35) sts.

RIGHT FRONT (Vee neck):

Cast on 43 (47, 51) sts. K. as Back from * to *. 000. K. 54 (60, 66) rows ***.

Shape raglan armhole and neck:

Dec. 1 st. at neck edge (left side) on next and every foll. 4th row, **at the same time** cast off 3 sts. beg. next row. K. 1 row. Dec. 1 st. at beg. next and every foll. alt. row until 6 (7, 8) sts. remain. Keeping neck edge straight, continue raglan shaping until 3 sts. remain. K. 3 tog. and fasten off.

LEFT FRONT (Vee neck):

Knit as Right Front, reversing all shapings.

RIGHT FRONT (Crew neck):

Knit as Vee neck to **.

Shape raglan armhole: Cast off 3 sts. beg. next row. K. 1 row. Dec. 1 st. beg. next and every foll. alt. row 16 (19, 21) times altogether.

Shape neck: Cast off 6 (7, 8) sts. beg. next row. Continue raglan shaping, k. 1 row. Cast off 2 sts. beg. next row. K. 2 rows. Dec. 1 st. at neck edge on next row. K. 1 row. Dec. 1 st. at neck edge on next and every foll. 4th row 3 times altogether. (4 (4, 5) sts. remain.)

Keeping neck edge straight, continue raglan shaping until 3 sts. remain. K. 3 tog. and fasten off.

LEFT FRONT (Crew neck):

Knit as Right Front, reversing all shapings.

SLEEVES:

Cast on 47 (51, 55) sts. K. as Back from * to *. 000. K. 6 (8, 10) rows. Inc. 1 st. both ends of next and every foll. 6th (7th, 8th) row 9 times altog. (65 (69, 73) sts.) Knit straight until 60 (72, 84) rows have been worked. (Adjust length here if required).

Shape raglan top: Cast off 3 (2, 2) sts. beg. next 2 rows. **3rd size only:** K. 2 rows **All sizes:** Dec. 1 st. both ends of next and every foll. alt. row 25 (28, 30) times altog. K. 1 row. Cast off remaining 9 sts.

TO MAKE UP:

Pin out and press with a hot iron over a damp cloth. Join side, sleeve and raglan seams. Work 3 rows of crochet along fronts and across back neck. **4th row:** Make 4 button loops for Vee neck and 5 button loops for crew neck along one front. Work 1 row of shell pattern. Sew on buttons. Press seams.

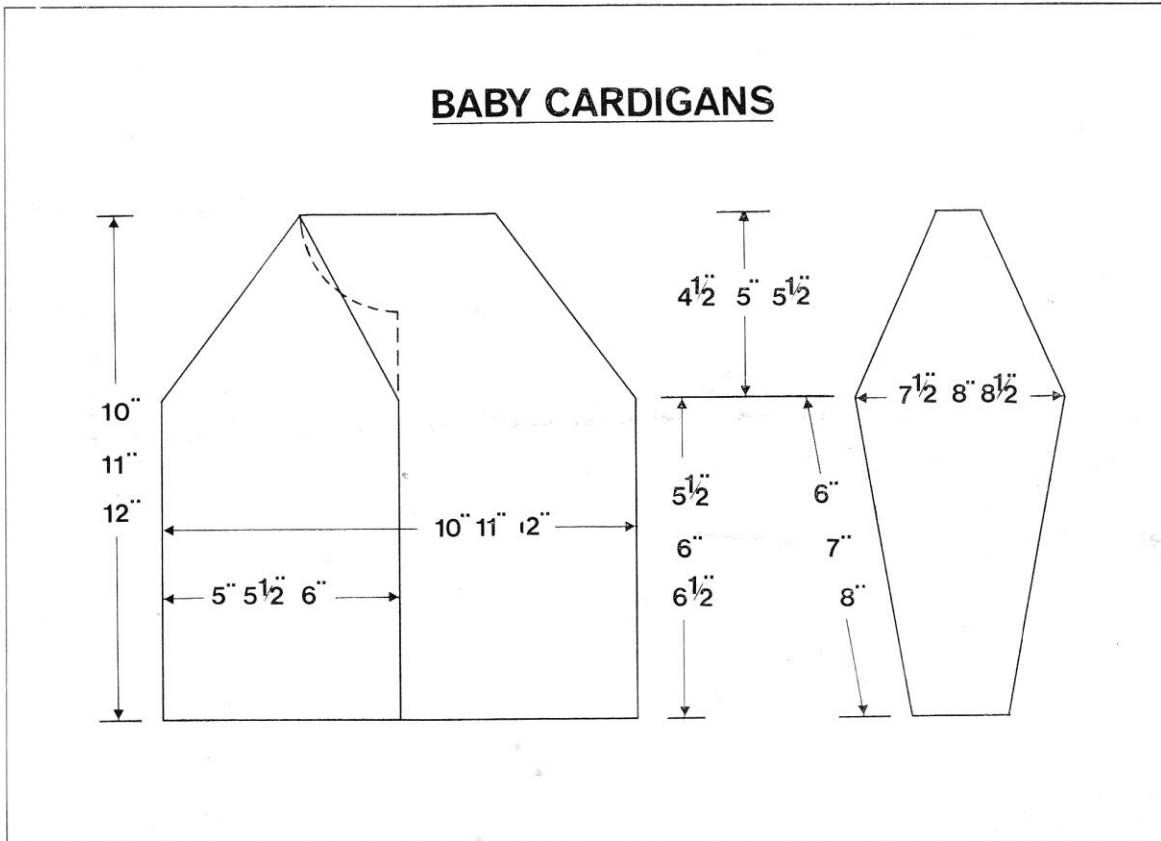



Pram Coat

MATERIALS: 7 (8, 9) oz. Hayfields Gaylon Double Knitting; 2 oz. Grossamer Knit 2 ply in contrast colour; 5 buttons; 1 yd. 1-in. facing ribbon.

MEASUREMENTS: To fit 18 (20, 22) inch chest. Actual measurements: 20 (22, 24) inches; Length at Centre Back, 14 (14½, 15) inches; Sleeve seam, 7 (7½, 8) inches.

TENSION: 14 sts. and 19 rows to 2 inches over stocking stitch.

ABBREVIATIONS: See inside front cover.

NOTES: Always carry the 2 ply yarn over needles in E. position when knitting with Double Knitting yarn with H.C.L.'s at I. Always take the yarn round the first needle in E. position. DO NOT press skirt or sleeves.

LEFT FRONT:

Using D.K., cast on 86 (92, 98) sts. by hand. T. 6. K. 8 rows. Carr. at R. T. 7. H.C.L.'s III. 000. Push 14 (16, 16) needles at L. to E. Using 2 ply yarn, K. 4 rows. Do not break off the yarn. H.C.L.'s I. Using D.K., k. 2 rows. H.C.L.'s III. The last six rows form the pattern and should be repeated throughout. K. 3 more patterns. (18 rows).

Shape neck: Keeping continuity of pattern and working 2 ply yarn over the same 72 (78, 82) sts. as before, inc. 1 st. at L. at beg. of next and every foll. alt. row worked in D.K. 5 (6, 6) times altog. Push 20 (22, 22) needles at L. to E. H.C.L.'s III. With 2 ply, k. 4 rows. H.C.L.'s I. With D.K., k. 1 row. Cast on 8 (8, 10) sts. K. 1 row.

Shape shoulder:*** Push 28 (30, 32) needles to E. Work 1 (1, 2) patterns. H.C.L.'s III. With 2 ply, k. 4 rows. H.C.L.'s I with D.K. K. 1 row. Dec. 1 st. at beg. of next row. Push 27 (29, 31) needles to E. Work 1 (2, 2) patterns. H.C.L.'s III. With 2 ply, k. 4 rows. H.C.L.'s I. With D.K., k. 1 row. Dec. 1 st. at beg. of next row. Continue dec. on the last D.K. row of every 3rd pattern (18 rows) twice more. Work 2 patterns. Push 24 (26, 28) needles to E. H.C.L.'s III. K. 4 rows. H.C.L.'s I with D.K. K. 1 row.

****Shape armhole:** Cast off 19 (21, 22) sts. K. 1 row. Continue in pattern dec. 1 st. on the 6th row of next and every foll. pattern 5 (5, 6) times altog. Work 2 patterns. H.C.L.'s III. With 2 ply, k. 4 rows. H.C.L.'s I with D.K. K. 1 row. Inc. 1 st. at beg. of next row. Continue inc. 1 st. on the 6th row of every foll. pattern 5 (5, 6) times altogether. Cast on 19 (21, 22) sts. at beg. of next 6th pattern row.

Shape shoulder: Inc. 1 st. at beg. of 18th pattern row 3 times altog, then inc. 1 st. at beg. of 12th (18th, 18th) pattern row once. Work 2 (2, 3) patterns

*** placing a marking thread in the first st. of last D.K. row to show beg. of back neck. K. 84 (96, 96) rows. (14 (16, 16) patterns), placing marking thread in first st. of last D.K. row. Now work from *** to ***

Shape right front: H.C.L.'s III with 2 ply. K. 4 rows. H.C.L.'s I with D.K. K. 1 row. Cast off 8 (8, 10) sts. K. 1 row. Dec. 1 st. on the 6th pattern row of next and every foll. 6th pattern row 5 (6, 6) times altog. H.C.L.'s III. With 2 ply, k. 4 rows. H.C.L.'s I. With D.K., k. 4 rows.

Counting from neck edge, make buttonholes over sts. 3, 4 and 5. Make 4 more with 3 sts. in each and 10 sts. apart. K. 4 rows. Cast off.

SLEEVES:

Using D.K., cast on 50 (54, 58) sts. by hand. T. 7. K. 2 rows. Push 8 needles at left to E. (cuff edge). Continue in pattern, working with the 8 sts. in D.K. for cuff. Work 2 (2, 3) patterns. Inc. 1 st. at R. on next and every foll. 18th pattern row 4 times altog. (11 (11, 12) patterns worked).

Work 3 (3, 4) patterns without shaping. Dec. 1 st. at R. on next and every foll. 18th pattern row 4 times altog.

Work 2 (2, 3) patterns. Cast off.

COLLAR:

Using D.K. only, cast on 70 (74, 78) sts. by hand. T. 5. K. 4 rows. T. 6. K.

4 (5, 6) rows. T. 7. Inc. both ends of next row. K. 4 (5, 6) rows. T. 8. Inc. both ends of next and foll. 4th (5th, 6th) rows. K. 4 rows. Slip sts. on to a fine knitting needle. Using 2 short needles, pick up 13 (15, 17) sts. along both ends of collar.

BORDER:

Using 2 strands of 2 ply, cast on 106 (112, 120) sts. by hand. T. 6. K. 7 rows. Counting from both ends, transfer the 12th (14th, 16th) sts. on to the 13th (15th, 17th) needles. Using the triple transfer tool, move the end sts. 1 st. in. With the P. side of collar facing the border sts., place 13 (15, 17) sts. from one end of collar on to the corresponding needles at end of border. Cast off both sets of stitches tog, by hand. Place the lower collar sts. over the next 76 (80, 84) needles. Cast off by hand. Cast off remaining sts. in the same way.

TO MAKE UP:

Join all seams. Sew collar in place, with both ends ½ inch in from front edges. Work 1 row of double crochet along front edges. Sew in facing ribbon. Neaten buttonholes. Turn up ¾ inch hem at lower edge of coat and hem lightly. Set in sleeves. Turn cuffs in half to inside and sew into position. Sew on buttons. Give yoke and collar and cuffs a final press on wrong side with a hot iron over a damp cloth.

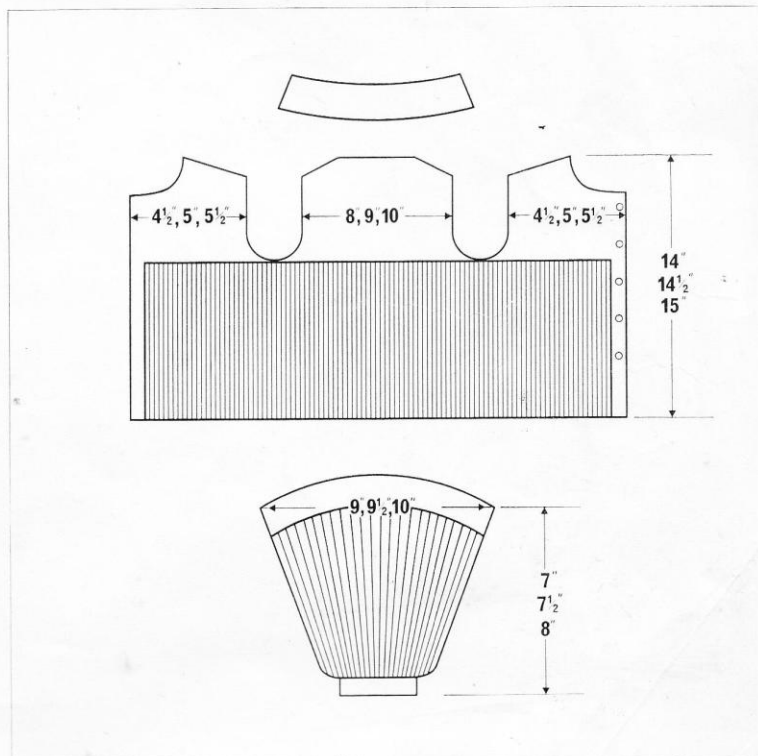

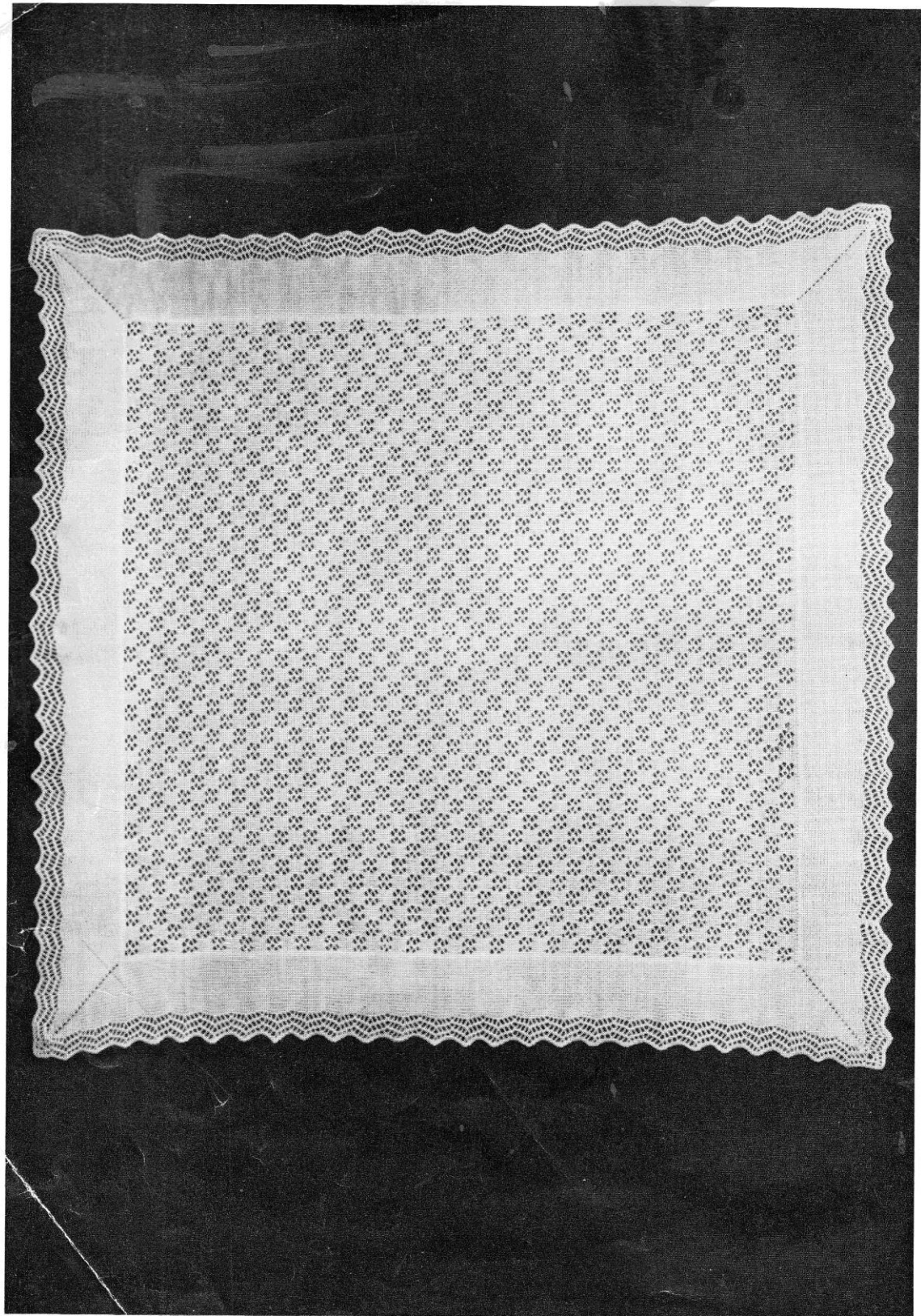



Baby's hat and booties

BABY'S HAT

MATERIALS: 1 oz. main colour, $\frac{1}{2}$ oz. contrast colour of Emu Acrilan 4-ply.

MEASUREMENTS: Round lower edge 15 inches.

TENSION: 8 sts. and 11 rows to 1 inch.

ABBREVIATIONS: See inside front cover.

Using odd yarn, cast on 40 sts. T.6. K. 6 rows. Change to C. T.3. K. 2 rows. Now work in stripes as follows: 000* H.C.L.'s III. Carr. at right. Always take yarn round first inside needle in E pos. Bring 8 needles at left to E pos. T.6. Using M., K. 2 rows. Bring 8 more needles at left to E. pos. K. 2 rows. Left H.C.L. to I. Change to T.3 and C. K. 2 rows.* Rep. from * to * 28 more times (174 rows on R.C.). Change to M. T.6. K. 2 rows. Using odd yarn, K. 6 rows and run work off machine.

Brim: With M. and right side of hat facing, pick up 108 sts. evenly along lower edge. T. 6. K. 40 rows. Change to C. and T.3. K. 2 rows. Break off C. Using M. and T.6, K. 24 rows. Cast off loosely. With right side facing, place sts. from hat onto needles. Place sts. from the second edge on top of these sts. and cast off tog.

TO MAKE UP:

Join brim. Sew edge of brim to cast-on edge inside hat. Gather top of hat. Make pom pom and sew firmly in position. Press with a warm iron over a dry cloth.

BABY'S BONNET

MATERIALS: 1 oz. Patons Purple Heather 4-ply; small amount contrast colour; medium crochet hook; 1 yd. 1 inch ribbon.

MEASUREMENTS: Diameter of side panels $4\frac{1}{2}$ inches; length of centre panel 10 inches.

TENSION: 8 sts. and 10 rows to 1 inch over st.st.

ABBREVIATIONS: See inside front cover.

TOP PANEL:

Using M., cast on 80 sts. automatically. T.5. K. 4 rows.* Press buttons 1, 3, 5 and 7. Set lever (for machines without the Lace Maker, bring every alt. needle to E. pos.). H.C.L.'s III. Using C., K. 2 rows. H.C.L.'s I. Change to M. K. 8 rows.* Rep. from * to * twice more. Work the 2 C. rows once more. Break off C. Using M., K. 5 rows. Cast off.

SIDE PANELS:

Using odd yarn, cast on 16 sts. T.5. K. 6 rows. 000. Change to M. K. 2 rows. Always take yarn round first needle in E. pos. H.C.L.'s III. **Bring 4 needles at opposite end to carr. to E. pos. K. 2 rows*. Rep. from ** to * twice more. H.C.L.'s II. *Take 4 needles back to C. pos. K. 2 rows*. Rep. from * to * twice more. H.C.L.'s III. Change to C. and work 2 patt. rows. as for top panel. ** H.C.L.'s II. Rep. from ** to ** 10 more times. H.C.L.'s I. Using M., K. 1 row. Slip sts. onto a st. holder. Turn and replace on needles with right side facing. Place sts. from first row on top of these sts. and cast off tog. Using C., work 90 double crochet evenly round edge of circles.

Next row: * 3 ch. 1 sl. st. into 1 d.c. Rep. from * to end. Work in the same way along back and front edges of Top Panel. Run a thread round centre edge of circles, pull up and fasten off. Press pieces with a fairly hot iron over a damp cloth. Join panels, easing centre panel round half of circle. Sew on ribbon.

BOOTEES

MATERIALS: Either yarn or wool used for hat or bonnet is suitable. 2 oz. small amount contrast colour; 6 small buttons; medium crochet hook.

MEASUREMENTS: Length of foot, 4 inches.

TENSION: 8 sts. and 10 rows to 1 inch.

LEFT BOOTEE

Using M., cast on 12 sts. by hand. T. 6. K. 2 rows. Inc. 1 st. at right on next and foll. 3 alt. rows (16 sts.). K. 10 rows. Change to T. 5. K. 15 rows. Slip sts. on to a st. holder. Cast on 28 sts. by hand. T. 6. K. 2 rows. Inc. 1 st. at left on next and foll. 3 alt. rows (32 sts.) * make a buttonhole at left edge by transferring 3rd and 4th sts. to 2nd and 5th needles. With empty needles in B. position, K. 1 row. Using transfer tool, twist the yarn and replace on empty needles to form cast-on sts. K. 7 rows*. Change to T. 5. Rep. from * to * twice more. K. 1 row. Carr. at right. Slip 4 sts. at left onto a st. holder. Bring 12 needles at left to B. pos. Place the 16 sts. from st. holder onto these needles. Now replace the 4 sts. from st.-holder on top of the last 4 sts., forming an under-wrap for buttons. K. 2 rows. Break off yarn. Place 15 sts. from both ends onto st. holders. (14 sts. remain on needles). K. 20 rows. By transferring the 2nd st. to 3rd needle and moving the 2 end sts. along, dec. 1 st. at both ends of next and every foll. alt. row 4 times altog. (6 sts. remain). Using a length of matching yarn, cast on 32 sts. by hand at beg. of next 2 rows. (70 sts. altog. Carr. at right) * Using C., K. 2 rows. Change to M. K. 4 rows*. Rep. from * to * once more. Using C., K. 2 rows. Bring 35 needles at left to E.

pos. *H.C.L.'s III. Dec. 1 st. at both ends of next and foll. 3 alt. rows. Slip sts. onto st. holder*. Break off yarn. Take needle back from E. to B. pos. and work from * to *. With right sides facing, graft or cast off both sets of sts. tog. Join edges to form toe. Press. Pick up 32 sts. along cast-on edge at left. Pick up 17 sts. along left side edge and of instep and slip 15 sts. from st. holder onto the same needle. With right sides facing, cast off the 2 sets of 32 sts. tog. Work right side to match. Press. Join back and heel seam. Press. Fold Bootee round instep and work 1 row of single crochet into the edge sts. Fold in the same way along the edge of the third strip and crochet round edge as before. Button stitch can be worked instead of crochet if preferred. Using C., work 1 row of single cr. round fronts and top edge. **Next row:** *2 ch. 1 sl. st. into 1 s. cr. Rep. from * to end. Press. Sew on buttons. Make right bootee to match, reversing all shapings.



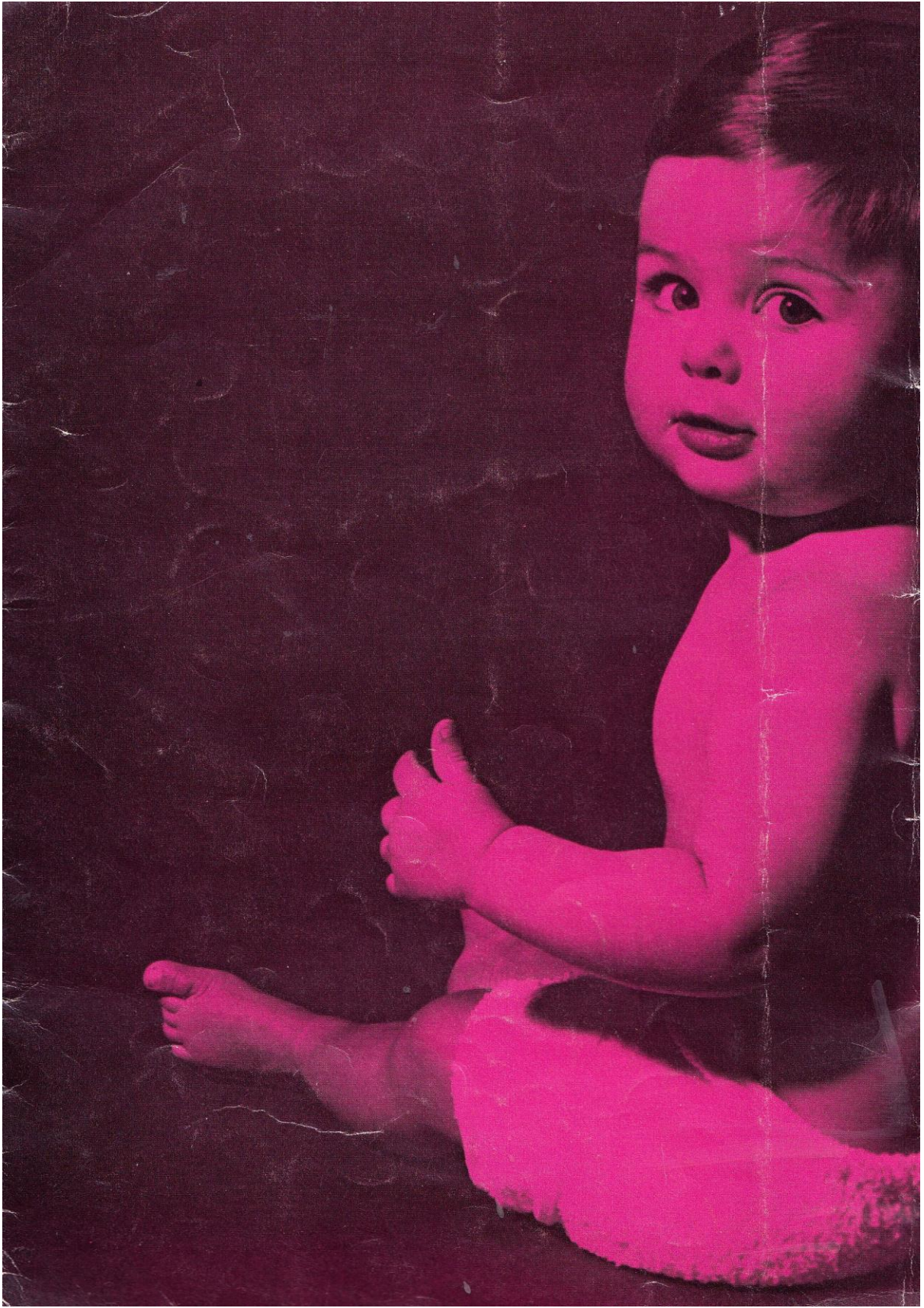

*Jones
Pattern
Booklet
No 1*

*First in
a series*

PRICE

4'6

*Babys'
Book*



